

REPORT DOCUMENTATION PAGE			Form Approved OMB NO. 0704-0188	
Public reporting burden for this collection of information is estimated to average 1 hour per response, including the time for reviewing instructions, searching existing data sources, gathering and maintaining the data needed, and completing and reviewing the collection of information. Send comment regarding this burden estimate or any other aspect of this collection of information, including suggestions for reducing this burden, to Washington Headquarters Services, Directorate for Information Operations and Reports, 1215 Jefferson Davis Highway, Suite 1204, Arlington, VA 22202-4302, and to the Office of Management and Budget, Paperwork Reduction Project (0704-0188), Washington, DC 20503.				
1. AGENCY USE ONLY (Leave blank)	2. REPORT DATE 10/31/98	3. REPORT TYPE AND DATES COVERED Final Report		
4. TITLE AND SUBTITLE Technology Development for Multilayered Microwave and Millimeter Wave Integrated Circuits		5. FUNDING NUMBERS DAAH04-95-1-0254		
6. AUTHOR(S) N.K. Das and D.M. Bolle		8. PERFORMING ORGANIZATION REPORT NUMBER		
7. PERFORMING ORGANIZATION NAMES(S) AND ADDRESS(ES) Polytechnic University Department of EE Six Metrotech Center Brooklyn, NY 11201		10. SPONSORING / MONITORING AGENCY REPORT NUMBER ARO 31427.13-EL		
9. SPONSORING / MONITORING AGENCY NAME(S) AND ADDRESS(ES) U.S. Army Research Office P.O. Box 12211 Research Triangle Park, NC 27709-2211		11. SUPPLEMENTARY NOTES The views, opinions and/or findings contained in this report are those of the author(s) and should not be construed as an official Department of the Army position, policy or decision, unless so designated by other documentation.		
12a. DISTRIBUTION / AVAILABILITY STATEMENT Approved for public release; distribution unlimited.				
13. ABSTRACT (Maximum 200 words) During the last three years of research under the ARO Grant # DAAH04-95-1-0254, we have contributed to the technology development for multilayer microwave/millimeter wave integrated circuits (multilayer MMICs) of the future. Such multilevel integration would allow implementation of smaller-sized, higher-density, and multi-functional microwave/millimeter wave circuits and systems, that are more reliable and cost-effective. Specifically, we have (1) investigated new transmission media that are better suited for multilayer integration, where conventional techniques may not work properly, (2) developed novel geometries for efficient signal transition between circuit layers in a multilayer environment, (3) developed new antenna and feeding structures that are specifically meant to work with multilayer integration, and (4) developed new theory and analytical/computational models for the design of transmission lines, layer-to-layer coupling structures, multilayer antenna feeds, which will greatly support the the future development of the multilayer MMIC technology. Our research shows, that there are several fundamental and technological issues that must be carefully considered to advance the multilayer microwave/millimeter wave integration concept. However, by using new techniques and devices, such as those developed by us, much more sophisticated and cost-effective circuits and systems can be built to meet the future demands in radar and wireless telecommunication.				
14. SUBJECT TERMS Microwave Circuits, Millimeter-Wave Circuits Multilayer MMIC			15. NUMBER OF PAGES DTIC QUALITY INSPECTED 8	
17. SECURITY CLASSIFICATION OF REPORT UNCLASSIFIED			16. PRICE CODE	
18. SECURITY CLASSIFICATION OF THIS PAGE UNCLASSIFIED		19. SECURITY CLASSIFICATION OF ABSTRACT UNCLASSIFIED		20. LIMITATION OF ABSTRACT UL

Technology Development for Multilayered Microwave and Millimeter Wave Integrated Circuits

Final Technical Report

By

Nirod K. Das, PI
Donald M. Bolle, Co-PI

October 1998

Submitted to
Army Research Office
Proposal # 31427-EL, Grant DAAH04-95-1-0254

Department of Electrical Engineering
Polytechnic University
Six Metrotech Center
Brooklyn, NY 11201

Approved for Public Release; Distribution Unlimited

The views, opinions, and/or findings contained in this report are those of the author(s) and should not be constructed as an official Department of the Army position, policy, or decision, unless so designated by other documentation.

Contents

1	Abstract	1
2	Technical Body	1
2.1	The Scope of the Investigation	1
2.2	Summary of Important Results	2
2.2.1	Transmission Media	2
2.2.2	Multilayer Transitions	2
2.2.3	Advanced Microstrip Antenna Integrated in Multiple Layers	3
2.2.4	Fundamental Effects in Multilayer Circuits	8
2.2.5	Analytical/Computational Modeling	8
2.2.6	Other Work of Interest	9
2.2.7	Future Work	10
2.3	List of Publications under the ARO Sponsorship	10
2.4	Scientific Personnel Supported, and Degrees Awarded	12
3	Report of Inventions (By Title Only)	12
4	References	12

1 Abstract

During the last three years of research under the ARO Grant # DAAH04-95-1-0254, we have contributed to the technology development for multilayer microwave/millimeter wave integrated circuits (multilayer MMICs) of the future. Such multilevel integration would allow implementation of smaller-sized, higher-density, and multi-functional microwave/millimeter wave circuits and systems, that are more reliable and cost-effective. Specifically, we have (1) investigated new transmission media that are better suited for multilayer integration, where conventional techniques may not work properly, (2) developed novel geometries for efficient signal transition between circuit layers in a multilayer environment, (3) developed new antenna and feeding structures that are specifically meant to work with multilayer integration, and (4) developed new theory and analytical/computational models for the design of transmission lines, layer-to-layer coupling structures, multilayer antenna feeds, which will greatly support the the future development of the multilayer MMIC technology. Our research shows, that there are several fundamental and technological issues that must be carefully considered to advance the multilayer microwave/millimeter wave integration concept. However, by using new techniques and devices, such as those developed by us, much more sophisticated and cost-effective circuits and systems can be built to meet the future demands in radar and wireless telecommunication.

2 Technical Body

2.1 The Scope of the Investigation

The general scope of the research completed under the ARO Grant # DAAH04-95-1-0254 include the fundamental, analytical, computational, as well as experimental investigations relating to multilayer microwave/millimeter wave integrated circuits. These multilayer circuits are to be implemented by stacking circuit layers on top of one another. The independent circuit layers need to be electrically isolated from each other by metal planes, while signal communication between the layers needs to be maintained at selected places. Compared to single-layered circuits that are common place today, such multilayer circuits will have different requirements and considerations. In this direction, the specific scope of the completed research covers the investigation of: (1) new transmission media, (2) mechanisms for efficient signal transitions between transmission lines, or between a transmission line and a microstrip antenna, placed in different layers, (3) new microstrip antenna design for advanced performance, that takes advantage of the multilayer technology, (4) fundamental new effects in multilayer environments, that might not normally occur in single-layer environments, and (5) analytical/computational models that are needed to design multilayer components. Our investigations contributed to develop some of the key building blocks in the above topics, as discussed in the following section.

2.2 Summary of Important Results

2.2.1 Transmission Media

As mentioned above, we investigated a number of fundamental and technical issues. We started by investigating new transmission media that would operate efficiently in the multilayer-circuit environment. The new transmission lines were studied with two basic issues in mind: (i) the transmission line should not “leak” power to the unwanted mode(s) of the parallel-plate structure, in which environment it has to function, and (ii) the transmission line should be fabricated in a convenient manner, and allow design of simple and efficient transitions between layers. These work are included in the listed publications [1,9,13,14]. The new transmission lines include (i) stripline, conductor-backed slot line, conductor-backed coplanar waveguide, with properly designed dielectric arrangements, (ii) “hybrid” transmission-line structures where a particular printed line in a parallel-plate arrangement is coupled with a surrounding dielectric guide, (iii) parallel-plate transmission lines with shorting posts in order to minimize any potential radiation loss - which may be seen as a local solution to any possible radiation leakage problems, and (iv) a dielectric guide embedded inside a parallel-plate structures, called a parallel-plate dielectric waveguide (PPDW for short).

2.2.2 Multilayer Transitions

We had a head start in this subject, with some earlier work done by our research group on the theory and modeling of multilayer transitions in Ref.[1, 2]. This background was useful as a theoretical tool for modeling and understanding of new transition geometries.

We considered specific new transition geometries, that address the critical problems in multilayer circuits discussed earlier. We considered the design of layer-to-layer transitions across metal planes, between two transmission lines, or between a transmission line and a microstrip antenna, employing probes or slots. The work on a microstrip-stripline-microstrip transition employing slot coupling, but with the help of a “dielectric plug” is reported in the publication list [15]. The work on a coaxial-to-PPDW transition is reported in the publication list [1,4,9]. Besides, key current results on the successful development of two other transitions (i) microstrip-PPDW-microstrip three-layer transition, and (ii) a microstrip-PPDW-microstrip antenna transition, are discussed in the following, that have not been published to date. A continuing doctoral thesis work is focused on the above transitions, the details of which will be included in the PhD Dissertation, and published in the open literature in due course.

(i) A Novel Microstrip-PPDW-microstrip Layer-to-Layer Transition for Multi-layer Integrated Circuits:

We have successfully developed the theory and design for a new 3-level transition device from a bottom microstrip layer to an intermediate parallel-plate dielectric waveguide (PPDW) layer, and then to a top microstrip layer. This device (see Figs.1 and 2) does not suffer from the problem of power loss to the parallel-plate modes. A total insertion loss of about 1.7dB is achieved, which is equivalent to only 0.85dB of insertion loss per one microstrip-PPDW transition. As verified, this amount is also partly due to reflection, not radiation loss. The performance is already good, but can be further improved by design optimization. In any event, the experiment demonstrates the feasibility of the proposed concept.

A theoretical model for the geometry has been developed, the results of which favorably compare with the experiment. The geometry basically consists of two microstrip-PPDW transitions connected back-to-back. A microstrip line on the bottom layer is match-coupled to a PPDW layer through an aperture on the common ground plane. The PPDW layer is then match-coupled to the microstrip line on the top surface through another slot on the top ground plane. Due to this arrangement, the slot does not radiate into the parallel-plate structure. Radiation from the slot is totally reflected from the PPDW boundary, and then is guided along the PPDW as useful power. If a stripline layer would be used in place of the PPDW, both the slot and the stripline can excite unwanted parallel-plate radiation. If a drill-through probe connection would be used between stripline layers, it will also suffer from excessive radiation to the parallel-plate structure.

(ii) Microstrip Line-PPDW-Microstrip-Antenna Feeding:

We first worked on modeling a microstrip antenna coupled through a slot to a PPDW running under it. This did not involve mechanism to excite the PPDW itself. We then used the results from our other work [1,4] to excite the PPDW from a microstrip line by using a probe transition. We then attempted to match the geometry by terminating one port of the PPDW by a short-circuit stub, and adjusting the slot dimension so that the antenna is impedance tuned. The geometry and experimental results for the matched microstrip-antenna feeding is shown in Figs.3 and 4, with the theoretical model to compare. We are successfully able to achieve perfect match from the experiment, which demonstrates the feasibility of the general concept. The general trend, resonant frequency of operation match with the theoretical model. The theory needs to be improved to provide better agreement in resonant impedance.

2.2.3 Advanced Microstrip Antenna Integrated in Multiple Layers

To take full advantage of the multilayer technology, diverse functions need to be integrated in multiple levels, in one place. It is natural to integrate microstrip antennas together

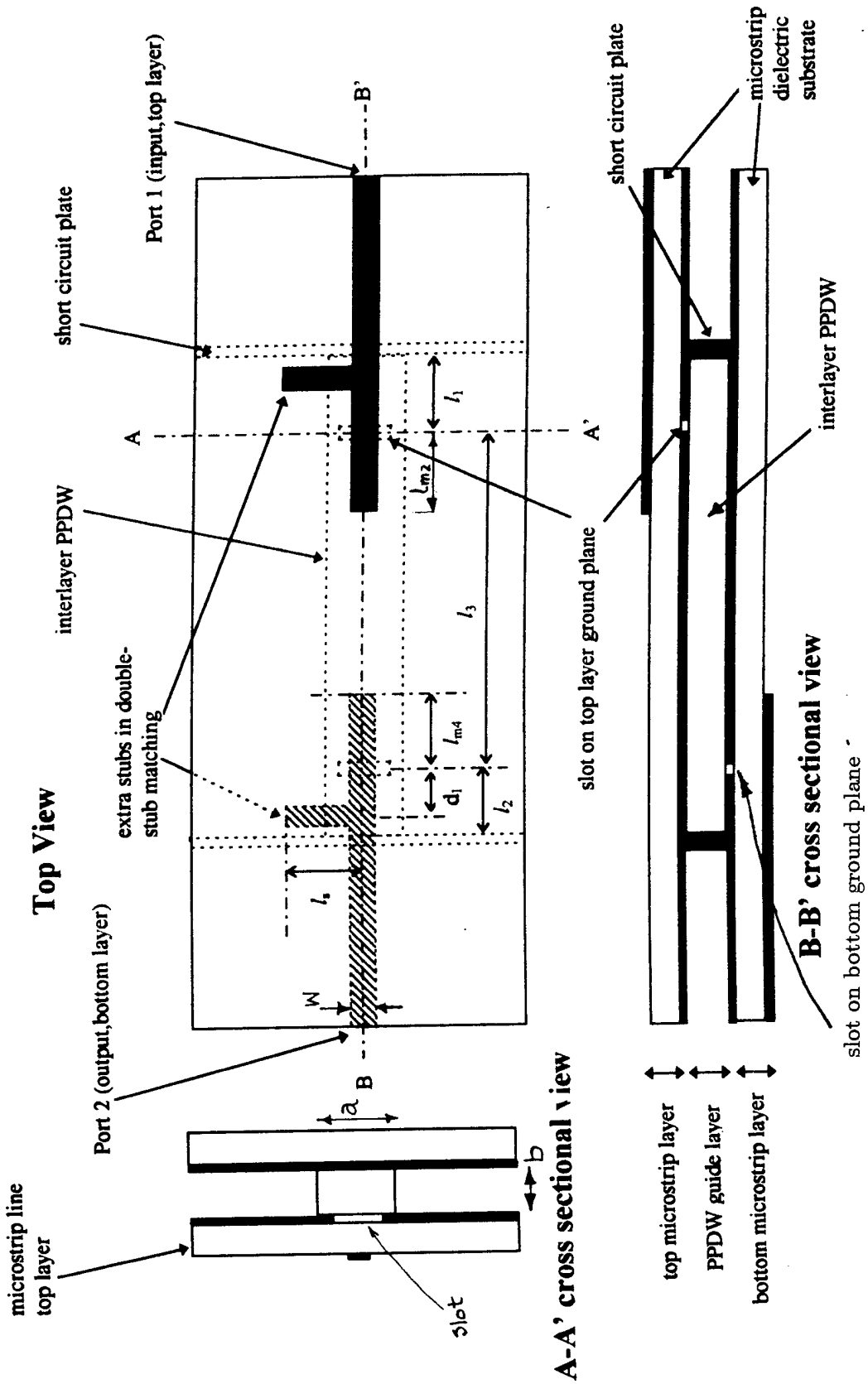

Figure 1. Physical geometry of aperture-coupled microstrip-PPDW-microstrip multilayer coupler.

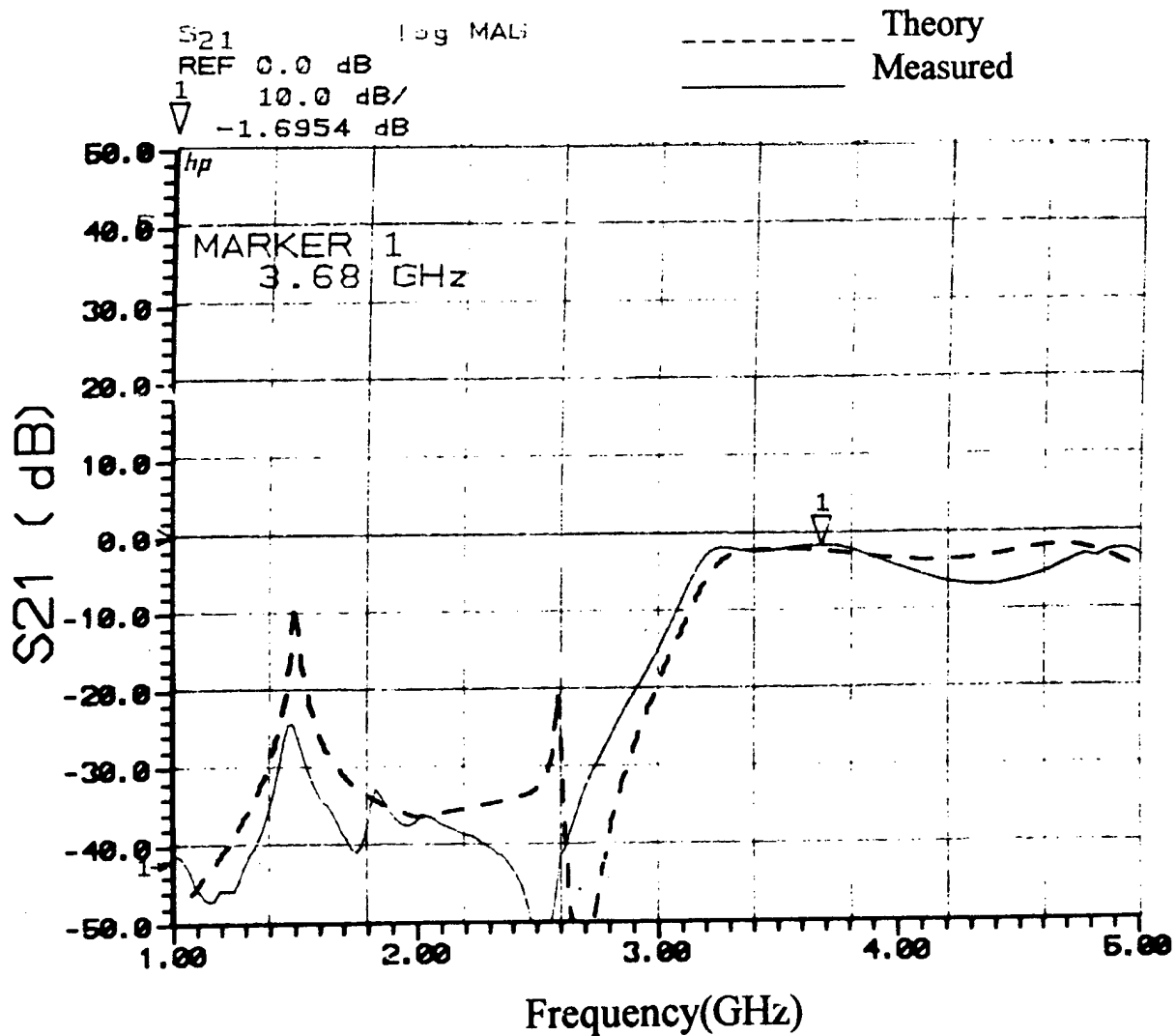

Figure 2. Measurement and computed values of S_{21} of an aperture-coupled Microstrip-PPDW-Microstrip interlayer coupler. Design dimensions are $l_1 = l_2 = 11\text{mm}$, and $l_{m2} = l_{m4} = 11\text{mm}$. Single-stub matching on top and bottom microstrip layers. PPDW: $\epsilon_r = 10.8$, $a = 14.4\text{mm}$, $b = 1.27\text{mm}$; Slot: $12 \times 1\text{mm}$; Microstrip: $\epsilon_r = 2.33$, width $W = 1.52\text{mm}$, characteristic impedance = 50Ω .

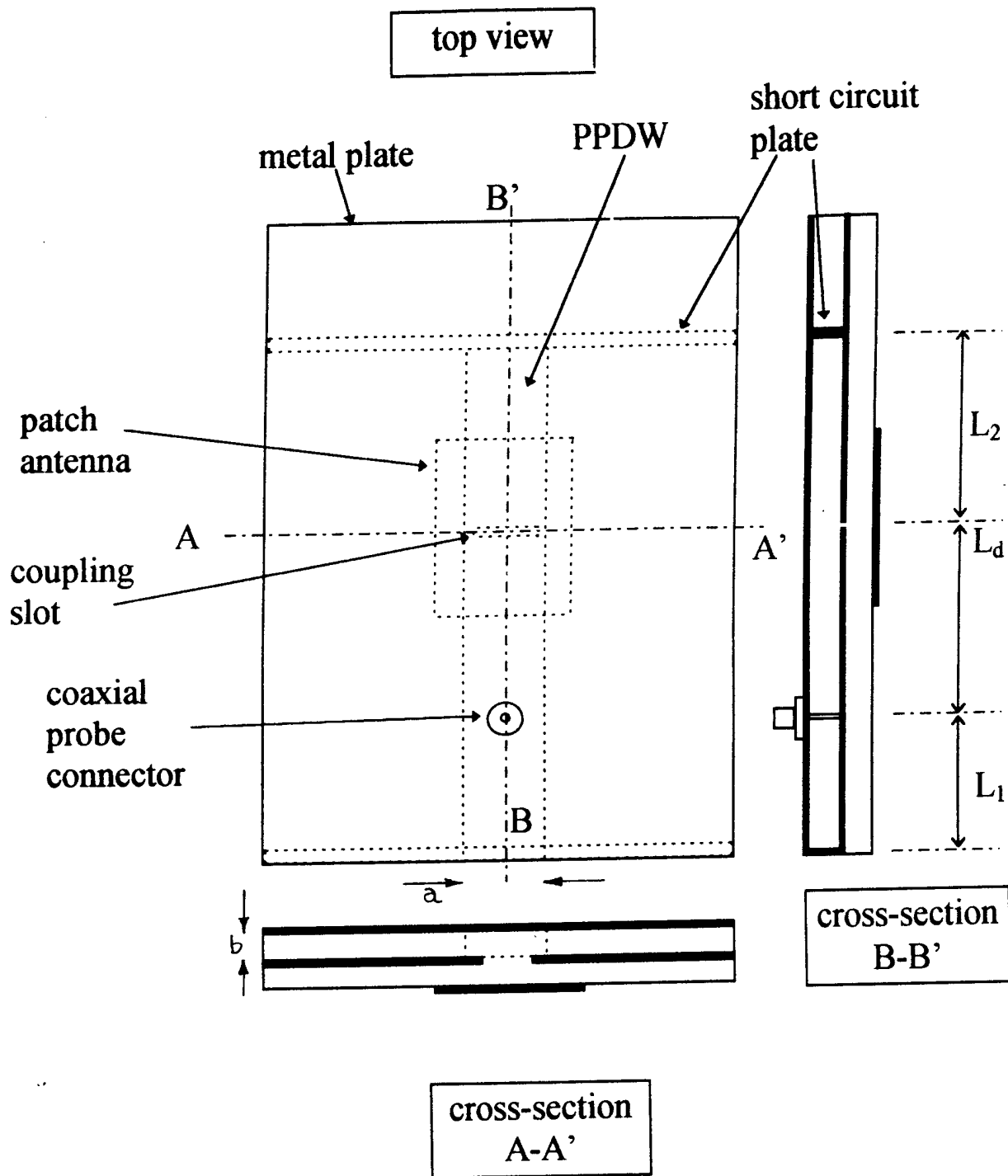

Figure 3. Device geometry of an aperture-coupled patch antenna fed by a Parallel-Plate Dielectric Waveguide (PPDW).

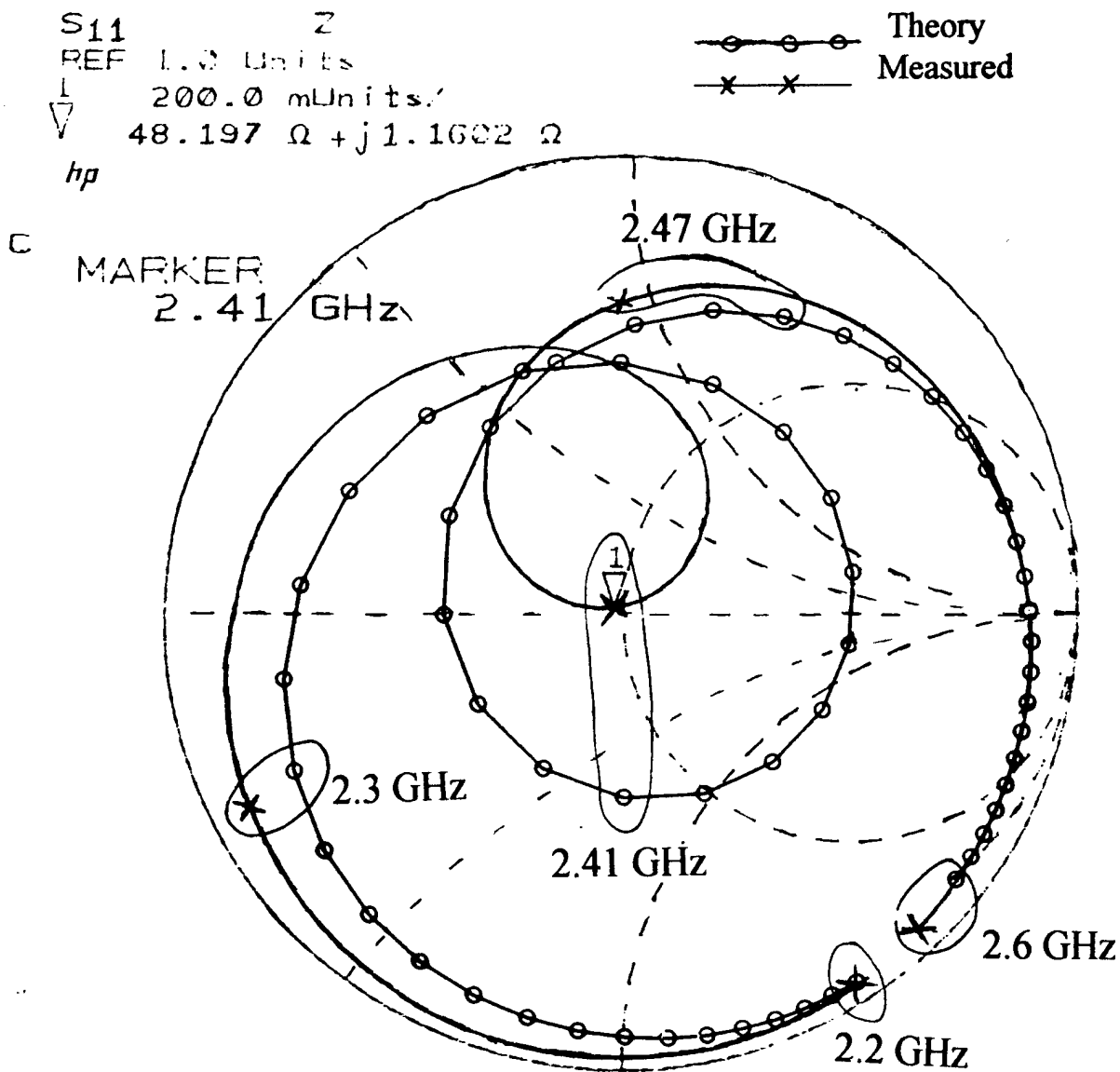

Figure 4. Measured and computed Smith-Chart plot of S_{11} for an aperture-coupled patch antenna fed by a PPDW. PPDW: $\epsilon_r = 10.8$, $a = 14.4\text{mm}$, $b = 5.08\text{mm}$; Slot: $12 \times 1\text{mm}$; Antenna substrate: $\epsilon_r = 2.33$, 60mils thick; Microstrip antenna: $20 \times 37.5\text{mm}$; $L_1 = 13\text{mm}$, $L_2 = 26\text{mm}$, $L_d = 70\text{mm}$.

with microwave circuits in multiple layers. Antennas with advanced characteristics can be designed making use of the flexibility provided by the multilayer technology. In this direction, we studied a novel multilayer microstrip antenna design, which is buried inside a multilayer arrangement, covered with a "metal grating layer". This arrangement provides low to ultra-low cross-polar radiation. The antenna may be coupled/excited by the microwave circuits using slot-coupling technique discussed earlier. The work is reported in the publications [6,7]. In addition, the work provided a analytical foundation to model arbitrary multilayer structures with arbitrary anisotropy.

2.2.4 Fundamental Effects in Multilayer Circuits

Power leakage to the parallel-plate modes is a critical consideration in multilayer circuits. Though the problems can be overcome by careful designs, the basic mechanism should first be understood. We conducted some of the basic studies, as reported in [13]. This paper studied mode conversion mechanism, the dynamics of excitation of the parallel-plate leakage, and characteristic impedance of a transmission line under such conditions. This followed some of our earlier work in Ref.[3].

Similar fundamental multilayer effects are also observed in other forms. Our work of [6,7] has contributed on this topic. The work of [6,7] shows, that radiating structures that are integrated with multilayer structures, that are in general non-uniform (axially) and anisotropic, can couple to complex modal structures. These complex modes would affect the performance of the antenna and/or any microwave circuits integrated on it.

2.2.5 Analytical/Computational Modeling

(i) A New Technique to Compute the Parameters of Complex Multilayer Transmission Lines: A multilayer integrated circuit will have to use new types of transmission line and waveguiding media. Due to the complexity of a multilayer configuration, it is essential to develop computational tools that can perform accurate and fast calculation of a general multilayer transmission line. Analytical expressions for the transmission line parameters would be impossible to achieve. Further, a computational method should be quite fast in order to perform not only analysis but also a number of design iterations. Existing methods for computing transmission line parameters, such as propagation constant, loss and characteristic impedance, can be computationally time consuming for general multilayer circuits, making them ineffective for design iterations.

We have recently completed the development of a new technique reported in [2], based on a fundamental transmission line theory and a method of moments procedure for determining the propagation constant, loss and characteristic impedance of any arbitrary multilayer line using a single computation. In addition, the method would also apply to transmission

lines with power loss to radiation or surface-guided modes, where the existing methods fail to work. The basic idea behind the new theory is that in the process of computation of the propagation constant of a multilayer line using a spectral-domain method of moment (commonly used for printed transmission lines,) there are additional information already available from which the loss and the characteristic impedance can be derived. Considering that the computation of characteristic impedance of a general multilayer can otherwise be formulationally and numerically quite involved, our new method should replace other approaches as a fast, powerful and accurate technique for circuit design purposes.

Modeling of the characteristic impedance of a transmission line, when the line experiences distributed radiation, was not understood in the past. This requires new treatment, and the conventional ways to define the characteristic impedance will not be useful. Our work reported in [10,12,13] have made some fundamental contribution in this subject. A proper definition of the characteristic impedance will be useful for circuit design purposes.

(ii) Computer Aided Analysis and Design Tools for Multilayer Circuits:

In order to support the technology development of multilayer MMICs, we are independently developing computer tools, specifically targeted for the analysis and design of multilayer transmission lines, transitions and antennas. This is done in collaboration with a small business, Microwave CAD Tools. These tools make use of several analysis techniques we have developed through the ongoing research in this area, and are intended to provide fast computation of various useful parameters that will allow complex design iterations.

2.2.6 Other Work of Interest

(i) We hosted an international conference on the Directions for the Next Generation of MMIC Devices and Systems at Polytechnic University during September 11-13, 1996. The conference was co-sponsored by Army Research Office, and the theme of the conference is directly related to the research grant covered by this report. The conference included non-parallel technical sessions and panel discussions. About 100 participants attended the conference from all over the world, including university, industry and government organizations.

The extended versions of selected papers were compiled and published last year by Plenum Press as a bound volume, entitled "Directions for the Next Generation of MMIC Devices and Systems," edited by Nirod K. Das and Henry L. Bertoni. Publication list [8]

(ii) In order to promote understanding of the general subject of the microwave/millimeter wave integrated-circuit technology, at a basic level, we authored a review article for publication in the Wiley Encyclopedia of Electrical Engineering, to be published in 1999. Publication list [2].

2.2.7 Future Work

The current research has demonstrated the feasibility and potential gains of the multilayer integration technology, and established only its foundations and required building-block components. In order to take it further, and take the full advantage of the technology, development of new circuit configurations, such as couplers, power dividers, hybrids, as well as antennas, that make use of the new multilayer transmission media we have developed here, must be investigated. Particularly, circuits that otherwise could not be imagined in a single-layer form should be explored. Some such circuits include, for example, (i) a large number of true-time delay, switched-line sections for true-time delay antenna steering, (ii) filter synthesis using large sections of transmission lines in multiple layers, which were not possible in single-layer forms due to the immense size and space requirements. Further, fabrication technology for reliable and cost effective manufacture of multilayer circuits, either by automated machining process or by using microelectronic process, must be developed. In addition, there may be need for still better wave-guiding concept and related multilayer integration architecture for much higher frequencies. Some of these work are being planned, with some initial initiatives already under way. We urge ARO to consider future research support in this direction.

2.3 List of Publications under the ARO Sponsorship

(Copies of the manuscripts [1,2,3,8], not sent to ARO before, are sent together with this report.)

- [1] "Coaxial-Probe to Parallel-Plate Dielectric Waveguide Transition: Analysis and Design Experiment," by G. K. C. Kwan and N. K. Das, IEEE Transactions on Microwave Theory and Techniques, submitted.
- [2] "A New Theory of the Characteristic Impedance of General Printed Transmission Lines, Applicable when Leakage Exists," by N. K. Das, IEEE Transactions on Microwave Theory and Techniques, submitted.
- [3] "Microwave and Millimeter Wave Integrated Circuits," by N. K. Das and D. M. Bolle, ' Wiley Encyclopedia in Electrical Engineering, to appear in 1999.
- [4] "Coaxial-Probe to Parallel-Plate Dielectric Waveguide Transition: Analysis and Experiment," by G. K. C. Kwan and N. K. Das, Proceedings of the 1998 Microwave Theory and Techniques Society Symposium, Baltimore, MD.
- [5] "On the Power Leakage Problem in Multilayer Printed Circuits," by N. K. Das, invited paper presented in the 1997 Progress in Electromagnetics Research Symposium, held in Cambridge, MA, July 1997 (appeared in the Symposium Proceedings.)
- [6] "Infinite Array of Printed Dipoles Integrated with a Layer of Printed Strip Grating for

Suppression of Cross-Polar Radiation, Part I: Rigorous Analysis," by N. K. Das and A. Mohanty, IEEE Transactions on Antennas and Propagation, pp.960-972, June 1997.

[7] "Infinite Array of Printed Dipoles Integrated with a Printed Strip Grating for Suppression of Cross-Polar Radiation, Part II: An Idealized Unidirectional Conducting Screen Approximation," by A. Mohanty and N. K. Das, IEEE Transactions on Antennas and Propagation, pp.973-981, June 1997.

[8] "*Directions for the Next Generation of MMIC Devices and Systems*," Plenum Press, New York, Editors N. K. Das and H. L. Bertoni, May 1997.

[9] "Multilayer Integration of Microwave and Millimeter Wave Circuits: New Interconnect Methods and Design Considerations," by N. K. Das, N. Herscovici, G. Kwan and D. M. Bolle, pp.83-95, in *Directions for the Next Generation of MMIC Devices and Systems*, Plenum Press, New York, Editors N. K. Das and H. L. Bertoni, May 1997.

[10] "Complex Characteristic Impedance of a Leaky Conductor-Backed Slotline: Alternate Analysis Methods, by N. K. Das, pp.315-321, in *Directions for the Next Generation of MMIC Devices and Systems*, Plenum Press, New York, Editors N. K. Das and H. L. Bertoni, May 1997.

[11] "Microstrip Antennas and Arrays Integrated With Strip Gratings," Doctoral Dissertation, Department of Electrical Engineering, Polytechnic University, 1997, awarded the Alexander Hessel Award for the best PhD Dissertation in the Electrical Engineering Department.

[12] "Spectral-Domain Analysis of Complex Characteristic Impedance of a Leaky Conductor-Backed Slotline," by N. K. Das, presented at the IEEE Microwave Theory and Techniques Society Symposium, San Francisco, June 1996.

[13] "Power Leakage, Characteristic Impedance and Leakage-Transition Behavior of Finite-Length Leaky Printed Transmission Lines," by N. K. Das, IEEE Transactions on Microwave Theory and Techniques, appeared in Vol.44, No.4, pp.526-536, April 1996.

[14] "Methods of Suppression or Avoidance of Parallel-Plate Power Leakage from Conductor-Backed Transmission Lines," by N. K. Das, IEEE Transactions on Microwave Theory and Techniques, appeared in Vol.44, No.2, pp.169-181, February 1996.

[15] "A Microstrip Array Fed by a New Type of Multilayer Feeding Network," N. Herscovici, N. K. Das and J. Klugman, presented at the International Conference on Electromagnetics in Advanced Applications, ICEAA 95, Politecnico Di Torino, Italy, September 1995.

2.4 Scientific Personnel Supported, and Degrees Awarded

- [1.] Nirod K. Das, PI.
- [2.] Donald M. Bolle, Co-PI.
- [3.] Godfrey Kwan, PhD Candidate, to finish soon.
- [4.] A. K. Mohanty, Doctoral Student (completed degree, awarded Prof. A. Hessel Best PhD Thesis Award of Polytechnic University, Department of Electrical Engineering, 1997.

3 Report of Inventions (By Title Only)

- [1.] New three-layer microstrip-PPDW-microstrip transition: analysis and design. This has the advantages of multilayer design, while eliminating the problem of power radiation to a parallel-plate layer.
- [2.] Aperture feeding of a microstrip antenna from a PPDW.
- [3.] An efficient coaxial-to-parallel plate dielectric waveguide (PPDW) transition.
- [4.] A new theory of characteristic impedance of multilayer transmission lines, including material and radiation leakage.
- [5.] New geometries (four classes) of printed, hybrid, and dielectric waveguide configurations with low leakage loss and/or low metal loss for multilayered MMICs.
- [6.] A new multilayer coupling method from one layer to another layer using a dielectric plug configuration. Patent pending (with N. Herscovici.)

4 References

- [1] N. K. Das. Generalized Multiport Reciprocity Analysis of Surface-to-Surface Transitions Between Multiple Printed Transmission Lines. *IEEE Transactions on Microwave Theory and Techniques*, MTT-41(7):1164-1167, July 1993.
- [2] N. K. Das and D. M. Pozar. Multiport Scattering Analysis of Multilayered Printed Antennas Fed by Multiple Feed Ports, Part I: Theory; Part II: Applications. *IEEE Transactions on Antennas and Propagation*, AP-40(5):469-491, May 1992.
- [3] N. K. Das and D. M. Pozar. Full-Wave Spectral-Domain Computation of Material, Radiation and Guided Wave Losses in Infinite Multilayered Printed Transmission Lines. *IEEE Transactions on Microwave Theory and Techniques*, MTT-39(1):54-63, January 1991.