

DOT/FAA/AR-97/79

Office of Aviation Research
Washington, D.C. 20591

Enhanced Reliability Prediction Methodology for Impact Damaged Composite Structures

19981218 050

October 1998

Final Report

This document is available to the U.S. public
through the National Technical Information
Service (NTIS), Springfield, Virginia 22161.

**Reproduced From
Best Available Copy**



U.S. Department of Transportation
Federal Aviation Administration

NOTICE

This document is disseminated under the sponsorship of the U.S. Department of Transportation in the interest of information exchange. The United States Government assumes no liability for the contents or use thereof. The United States Government does not endorse products or manufacturers. Trade or manufacturer's names appear herein solely because they are considered essential to the objective of this report.

1. Report No. DOT/FAA/AR-97/79		2. Government Accession No.		3. Recipient's Catalog No.	
4. Title and Subtitle ENHANCED RELIABILITY PREDICTION METHODOLOGY FOR IMPACT DAMAGED COMPOSITE STRUCTURES				5. Report Date October 1998	
				6. Performing Organization Code	
7. Author(s) H. P. Kan				8. Performing Organization Report No.	
9. Performing Organization Name and Address Military Aircraft Systems Division Northrop Grumman Corporation One Hornet Way El Segundo, California 90245-2804				10. Work Unit No. (TRAIS)	
				11. Contract or Grant No. Task 25, NAS1-19347	
12. Sponsoring Agency Name and Address U.S. Department of Transportation Federal Aviation Administration Office of Aviation Research Washington, DC 20591				13. Type of Report and Period Covered Final Report	
				14. Sponsoring Agency Code AAR-431	
15. Supplementary Notes The Federal Aviation Administration William J. Hughes Technical Center COTR is Peter Shyprykevich					
16. Abstract A through review of the existing impact test data and analysis methods was conducted and the results were used to identify a reliability prediction methodology for further development. The integrated residual strength/reliability method developed by Northrop Grumman under a Navy/Federal Aviation Administration sponsored program was selected and modified. The modification was primarily in reducing the number of empirical constants required in the model. In addition, a cutoff energy level and a threshold energy level were also established analytically for the strength prediction. A structural damage tolerance evaluation was conducted using the modified model and the results compared to those obtained from the existing model.					
17. Key Words Damage tolerance, Impact, Stiffness reduction, Residual strength, Reliability				18. Distribution Statement This document is available to the public through the National Technical Information Service (NTIS), Springfield, Virginia 22161.	
19. Security Classif. (of this report) Unclassified		20. Security Classif. (of this page) Unclassified		21. No. of Pages 90	22. Price

TABLE OF CONTENTS

	Page
EXECUTIVE SUMMARY	vii
1. INTRODUCTION	1
2. TECHNOLOGY ASSESSMENT	2
2.1 Experimental Data	2
2.2 Analysis Methods	18
3. ANALYTICAL METHOD DEVELOPMENT	20
3.1 Stiffness Reduction Model	21
3.1.1 Baseline Model	21
3.1.2 Structural Configuration Effects	23
3.1.3 Reliability Analysis	24
3.2 Model Modification	27
3.2.1 Energy Level Effects	27
3.2.2 Full-Penetration Stress Concentration Parameter	27
3.2.3 Structural Configuration Effects	29
3.2.4 Characterization of Data Scatter	29
4. ANALYTICAL RESULTS	30
4.1 Comparison of Results	30
4.1.1 Example 1	30
4.1.2 Example 2	32
4.2 Structural Evaluation	32
4.3 Effects of Scatter Parameters	37
5. CONCLUSIONS AND RECOMMENDATIONS	39
5.1 Summary	39
5.2 Conclusions	39
5.3 Recommendations	40
6. REFERENCES	40
APPENDIX A—Computer Programs	

LIST OF FIGURES

Figure		Page
1	Effects of Typical Impact Energy on Fiber Failure Length, Rank 1/14	12
2	Effects of Impact Energy on Damage Area, Rank 1/14	12
3	Effects of Impactor Diameter on Fiber Failure Length, Rank 2/14	13
4	Effects of Impactor Diameter on Damage Area, Rank 2/14	13
5	Effects of Laminate Thickness on Fiber Failure Length, Rank 3/14	14
6	Effects of Laminate Thickness on Damage Area, Rank 11/14	14
7	Effects of Matrix Type on Fiber Failure Length, Rank 14/14	15
8	Effects of Matrix Type on Impact Area, Rank 3/14	15
9	Fiber Type/Stiffener Spacing Interaction on Fiber Failure Length	16
10	Fiber Type/Stiffener Spacing Interaction on Impact Damage Area	17
11	Stiffness Reduction Model	21
12	Structural Configuration Effects	24
13	Schematic of the Integrated Reliability Analysis Methods	25
14	Probability Distribution of Impact Threats	26
15	Effects of Cutoff and Threshold Energies on Residual Strength—Thick Laminate	28
16	Effects of Cutoff and Threshold Energies on Residual Strength—Thin Laminate	28
17	Structural Reliability for Region 8	36
18	Structural Reliability for Region 30	36
19	Effects of Laminate Strength Scatter on Reliability	38
20	Effects of Structural Strength Scatter on Reliability	39

LIST OF TABLES

Table		Page
1	Summary of Test Results in Reference 6	3
2	Summary of Test Results in Reference 7	4
3	Summary of Test Results in Reference 8, Layup, 12 Ply, (33/67/0)	6
4	Summary of Test Results in Reference 9	7
5	Variables and Their Values Used in DOE	10
6	Ranking of the Intrinsic Variables for Hail Simulation Impacts	11
7	Ranking of All Impact Parameters in the Full DOE	11
8	Ranking of Two-Variable Interaction on the Impact Damage Resistance	16
9	Weibull Parameters for the Probabilistic Impact Threats	26
10	Effects of Laminate Layup on the Value of the Through Penetration Parameter C_2	29
11	Comparison of Results, PISTRE1 Versus PISTRE3	31
12	Comparison of Results, PISTRE2 Versus PISTRE4	32
13	Subdivisions of the F/A-18A Inner Wing Skin for Damage Tolerance Evaluation	33
14	Results of the Structural Damage Tolerance Evaluation	35
15	Effects of the Structural a_0 on Damage Tolerance	37
16	Effects of Scatter Parameters on Damage Tolerance Design Allowables	38

EXECUTIVE SUMMARY

Composite aircraft structures exposed to low-velocity impact can sustain extensive internal damage without visual signs of damage on the impacted surface. This internal damage can cause significant reduction in the strength of the structure. Concerned about the strength degradation caused by the nonvisible damage, the Federal Aviation Administration (FAA) requires that composite structures containing barely visible impact damage (BVID) shall not fail under the design ultimate load (DUL). Compliance of this damage tolerance requirement is usually demonstrated by tests using a building block approach. Even though analytical methods have been developed during the last 15 years, no analysis has been performed in certifying civil aircraft composite parts. The objective of this program is to use the model developed under a series of FAA/Navy/Air Force sponsored programs as a baseline to develop an advanced impact damage evaluation methodology suitable for composite structural certification.

A thorough review of the existing impact test data and analysis methods was conducted. The results of this review indicated that experimental data generated in the past 10 years are mostly concentrated in special applications. The impact research has emphasized the division between damage resistance and damage tolerance. The technology assessment also found that impact data have been generated for a variety of material forms (fabric, sandwich constructions, stitched laminates, etc.) on different structural configurations and under different type of loads. Improved analytical methods, in both damage resistance and damage tolerance, have been developed during the last 10 years. However, a considerable amount of research is still needed to provide an engineering tool for damage tolerance evaluation of composite structures.

The stiffness reduction model and the reliability analysis method developed by Northrop Grumman under an FAA/Navy sponsored program were modified under the current research effort. The modification was primarily in reducing the empirical constants required in the model. The empirical stress (strain) distribution used in the original model was replaced by an analytical solution based on the elasticity formulation. In addition, a cutoff energy level and a threshold energy level were also established analytically for the strength prediction.

A structural damage tolerance evaluation was conducted using the enhanced methodology and the results are compared to those obtained from the original model.

1. INTRODUCTION.

Composite aircraft structures exposed to low-velocity impact can sustain extensive internal damage without visual signs of damage on the impacted surface. This internal damage can cause significant reduction in the strength of the structure. Concerned about the strength degradation caused by the nonvisible damage, the Federal Aviation Administration (FAA) requires that composite structures containing barely visible impact damage (BVID) shall not fail under the design ultimate load (DUL). Compliance of this damage tolerance requirement is usually demonstrated by tests using a building block approach. Even though analytical methods have been developed during the last 15 years, no analysis has been performed in certifying civil aircraft composite parts.

Analytical prediction of the residual strength of an impact damaged composite structure can be divided into two steps, damage characterization and residual strength prediction. In the damage characterization stage, also referred to as damage resistance in the literature, the impact event is mathematically modeled and the nature and extent of the damage are predicted. Several damage prediction models have been proposed in the literature; however, an accurate analysis method is not currently available for damage tolerance certification. This is because of the extremely complex nature of the damage and the large number of factors affecting the damage. Analytical prediction of internal impact damage involves a complex three-dimensional stress analysis and the development of a well-defined failure criteria for a multitude of failure modes. The variables that need to be considered include the velocity, mass, shape, and mechanical properties of the impactor; the location and the angle of the impact; and the mechanical properties and support condition of the target. Currently available methods generally describe the key parameters with reasonable accuracy up to the damage initiation. Beyond damage initiation the assumptions of these methods are no longer valid. Thus the nature and extent of damage, which are essential in the residual prediction, cannot be reliably predicted with these models.

A semiempirical method, developed in reference 1, combines all internal damage resulting from a low-velocity impact into an equivalent region of reduced stiffness. The model captures the effects of all significant impact parameters and is simple in engineering application. In this model, the degree of stiffness reduction for a given material system and impact condition is assumed to depend on the impact energy. The influence of the other parameters that affect the postimpact compression strength of a laminate are empirically incorporated. The parameters considered are laminate layup, laminate thickness, material toughness, support condition, impactor size, and structural configuration.

The stiffness reduction model [1] was used as a baseline strength prediction method in the damaged structure reliability analysis model developed in reference 2. The reliability model integrates the residual strength prediction technique, the strength data scatter, and the impact threat distribution into a single reliability computation. The residual compression strength and the impact threat are combined to form a compounded probabilistic distribution to determine the damage structural reliability at a given applied stress (strain).

The reliability model [2] is practical from an engineering point of view. It is also sufficiently accurate for damage tolerance evaluation and certification, since the model incorporates the effects of all the important parameters during an impact event. However, because of the empirical nature of the stiffness reduction technique, an extensive amount of experimental data are required for the model calibration. In order to ease the application of the model, the number of empirical coefficients and the amount of required test data need to be reduced.

The objective of this program is to use the model developed in references 1 and 2 as a baseline to develop an advanced impact damage evaluation methodology suitable for composite structural certification.

A thorough review of the existing impact test data and analysis methods was conducted and the results are documented in section 2 of this report. Section 3 describes the analytical method development. A sensitivity study was performed, using the developed method, and the results are discussed in section 4. Conclusions and recommendations based on this investigation are presented in section 5. The analysis method was coded into two computer programs and they are listed in the appendix.

2. TECHNOLOGY ASSESSMENT.

Existing technology was assessed to identify the key parameters affecting the impact damage of composite structures and to determine possible interactions between impact parameters on the postimpact strength.

2.1 EXPERIMENTAL DATA.

A considerable amount of impact data has been generated since the development of the stiffness reduction model [1]. The current survey of experimental data was concentrated on these more recent data. Test data and impact test methods developed before 1987 were summarized in excellent reviews in the literature, such as references 1 and 3-5.

In reference 6, a series of experiments were conducted on two composite material systems, graphite epoxy (AS4/3501-6) and graphite bismaleimide (IM6/CYCOM3100). The impact parameters considered were impact velocity, impact energy, laminate thickness, and layup. The results were measured in terms of damaged area and postimpact compression strength. The baseline layup for both materials tested was 10 percent 0° plies, 80 percent ±45° plies, and 10 percent 90° plies, or, (10/80/10). The laminate thickness ranged from 9 ply thick to 96 ply thick. The impact energy applied was based on the damage tolerance requirements of the US Air Force [1]. The results of reference 6 indicated that the per ply postimpact compressive strength for either the Gr/Ep or the Gr/BMI composites is fairly constant for all thicknesses and under the USAF damage tolerance requirements the Gr/BMI system appears to offer no advantage in damage tolerance over the Gr/Ep system. The data generated in reference 6 is a good source for the model development and parametric study. These test data are summarized in table 1 and will be discussed further in section 4.

TABLE 1. SUMMARY OF TEST RESULTS IN REFERENCE 6

Layup	Energy (ft-lb)	Percent Energy Absorbed	Impact Velocity (ft/sec)	Damage Area (in ²)	Dent Depth (in)	Residual Compression (ksi)
AS4/3501-6 Specimens						
9 ply (22/67/11)	9.10	81	8.235	1.00	Through	15.16
26 ply (12/76/12)	35.61	83	14.698	3.00	0.10	21.81
48 ply (13/74/13)	91.32	79	12.172	16.00	0.10	16.50
74 ply (12/76/12)	100.14	49	12.730	18.00	--	18.00
96 ply (13/74/13)	100.16	38	12.730	18.00	--	20.23
IM6/CYCOM3100 Specimens						
9 ply (22/67/11)	9.15	37	0.000	0.97	Through	17.27
26 ply (12/76/12)	35.51	36	12.270	20.61	0.10	19.27
48 ply (13/74/13)	91.50	27	13.845	26.29	0.10	16.62
74 ply (12/76/12)	100.51	38	14.501	23.41	--	16.92
96 ply (13/74/13)	100.39	43	14.501	21.43	--	20.04

- Notes: 1. All specimens were 7 in. wide and 10 in. long.
 2. All specimens impacted with 1.0-in.-diameter impactor.

An experimental/analytical investigation on stitched Gr/Ep material (AS4/3501-6) used in the resin film infused (RFI) process is presented in reference 7. Even though the data presented in the reference are not directly suitable for the model development in the current program, this reference provides useful information towards understanding the key impact parameters and modeling techniques. A brief discussion is included here and the experimental results are summarized in table 2.

The baseline laminate layup used in reference 7 is (44/44/12) with thickness ranges from 0.216 to 0.648 inch (or 36 to 108 plies thick). The impact energy ranges from 20 ft-lb to as high as 300 ft-lb, depending on the laminate thickness. Micrographs were obtained and c-scan damage areas were measured for the specimens to determine the extent of the delaminations. Dent depths were also measured for each impact damage. The dent depth is used in the reference to classify impact damage. Three classes of damage were used in the study: (1) low damage level with less than 0.01-inch-deep dent, (2) medium damage level with dent depth between 0.01 and 0.04 inch, and (3) high level of damage with larger than 0.04-inch-deep dent. It was found in reference 7 that dent depth measurements provide a good tool for residual strength correlation for the material system.

The general conclusions worth noting from reference 7 are

1. The strain gage and micrograph results indicated that given the same level of damage (defined by dent depth), the thicker panel will have a larger damage zone.

TABLE 2. SUMMARY OF TEST RESULTS IN REFERENCE 7

Layup*	Impact Energy (ft-lb)	Impact Force (lb)	Dent Depth (in)	Residual Compression (ksi)	Support Condition
36 ply	30.5	2095	0.052	40.88	C-F
36 ply	39.4	2014	0.120	39.90	C-F
54 ply	25.5	3308	0.000	60.83	C-C
54 ply	29.8	3839	0.015	56.70	C-C
54 ply	40.0	--	--	50.20	C-C
54 ply	70.0	--	--	51.00	C-C
54 ply	100.0	--	--	39.90	C-C
54 ply	39.3	3813	0.000	53.75	C-F
54 ply	73.7	3942	0.007	48.00	C-F
54 ply	100.1	3863	0.170	42.90	C-F
72 ply	20.2	2609	0.00	72.00	C-C
72 ply	30.0	5468	0.00	69.40	C-C
72 ply	40.8	4496	0.01	63.40	C-F
72 ply	73.3	5609	0.02	53.10	C-F
72 ply	100.0	5892	0.05	50.30	C-F
72 ply	127.4	5984	0.09	50.10	C-F
72 ply	139.2	6311	0.09	48.60	C-F
72 ply	148.5	5778	0.14	46.20	C-F
90 ply	29.2	5698	0.00	77.00	C-C
90 ply	33.7	5713	0.00	70.00	C-C
90 ply	40.3	5592	0.00	69.20	C-C
90 ply	72.2	6515	0.02	60.20	C-F
90 ply	99.7	7642	0.03	54.60	C-F
90 ply	148.0	7631	0.06	46.10	C-F
90 ply	205.2	8000	0.10	45.40	C-F
90 ply	255.8	7928	0.25	44.10	C-F
108 ply	99.7	9241	0.03	66.30	C-F
108 ply	105.8	9654	0.03	59.60	C-F
108 ply	203.7	11036	0.04	49.80	C-F
108 ply	301.3	11104	0.11	44.30	C-F

Notes: *All AS4/3501-6, stitched laminates with RFI process.

1. All laminates with (44/44/12) layup.
2. All specimens 7 in. wide, 12 in. long.
3. All specimens impacted with 0.5-in. impactor.

2. Delamination growth does not play a significant role in initiating catastrophic failure in stitched/RFI composites.
3. Local concentration of axial and bending forces in the damage region initiate compression failure.
4. The effects of damage remained local and contained even up to failure.
5. Significant variables affecting impact force are the shape of contact region of impactor and the kinetic energy of impactor.
6. The resulting shear, axial, and bending forces due to impact force depend upon the stiffness of the impact site and how the impact force is reacted, the boundary conditions of the panel, and the dynamic effects.
7. The impact force can be predicted by separating the kinetic energy into elastic and Hertzian contact energy.

In an attempt to correlate the state of damage with the residual compressive strength, an experimental investigation was carried out in reference 8. AS4/3501-6 graphite/epoxy laminates with (33/67/0) layup and different thicknesses were impacted with different levels of energy. The test data presented in the reference are summarized in table 3.

Compressive residual strengths were evaluated using honeycomb sandwich specimens with 1-inch-thick aluminum core. An impacted coupon and an undamaged coupon were bonded to the aluminum honeycomb core to form the sandwich specimen for residual strength test. The key observation based on the results of this study is that the state of damage is three-dimensional in nature. Two-dimensional damage characterization, such as c-scan or x ray, does not provide sufficient information for residual strength prediction. These observations agree well with that reported in references 1 and 2. In addition, references 1 and 2 also suggest that under identical impact conditions the scatter in the damage area detected by c-scan is significantly higher than that of the undamaged laminate strength. The implication here is that the damage resistance of a laminate is difficult to characterize as well as difficult to analytically predict. Even if the state of damage is fully characterized and predictable, prediction of damage tolerance depends on the development of a fully three-dimensional damage mechanics method at a micro mechanics level.

AS4/3502 graphite/epoxy and AS4/PEEK graphite/thermoplastic specimens were tested in reference 9 to evaluate the effects of impact damage and damage location on the residual strength (both tension and compression) of the specimen. The laminate layup used in this reference was either (50/50/0) or (0/80/20), and the thickness ranged from 8 to 30 plies. The impact velocity ranged from 50 to 550 ft/sec with impact energy up to 30.7 ft-lb. Specimens were impacted on mid-length either at mid-width or near a lateral unloaded edge. The results of this study indicated that effects of impact location depended on the laminate thickness, layup, and loading mode. For thin tensile specimens, impact location only affected the (0/80/20) specimens but not the (50/50/0) laminates. Similarly, under compression load the location effects were more significant for the (0/80/20) specimens. A special feature in this study was that the compression

TABLE 3. SUMMARY OF TEST RESULTS IN REFERENCE 8, LAYUP, 12 PLY, (33/67/0)

Impact Velocity (ft/sec)	Impactor Weight (lb)	Impact Energy (ft-lb)	Damage Area (in ²)	Residual Compression (ksi)
116.803	0.0185	3.93	0.20	49.20
139.63	0.0185	5.61	0.34	44.41
151.12	0.0185	6.58	1.20	37.17
167.91	0.0185	8.11	0.51	36.57
180.72	0.0185	9.40	0.70	35.43
189.06	0.0185	10.29	0.97	33.02
197.96	0.0185	11.28	1.37	30.46
229.77	0.0185	15.19	1.47	31.32
24.76	1.274	12.14	1.02	45.41
26.52	1.274	13.92	0.84	47.80
28.35	1.274	15.92	1.11	41.73
30.18	1.274	18.04	1.45	41.25
32.85	1.274	21.37	1.37	41.91
35.85	1.274	25.46	1.05	45.33
39.52	1.274	30.93	1.00	44.73
14.63	3.357	11.18	0.80	50.38
15.79	3.357	13.01	1.28	41.89
17.20	3.357	15.43	1.31	41.87
18.11	3.357	17.11	1.33	43.08
18.77	3.357	18.38	1.96	34.10
19.68	3.357	20.20	1.60	39.20
20.67	3.357	22.29	2.16	33.60
21.74	3.357	24.67	2.04	34.59
23.07	3.357	27.76	2.01	35.22
24.47	3.357	31.25	1.93	33.48
28.11	3.357	41.23	2.05	25.59

- Notes: 1. All AS/3501-6 laminates.
 2. All specimens impacted with 0.5-in impactor.

specimens were not side constrained, and therefore, specimen failure was affected by specimen buckling. Thus, the failure mode was dominated by the specimen thickness. The test data generated in reference 9 are summarized in table 4.

TABLE 4. SUMMARY OF TEST RESULTS IN REFERENCE 9

Layup	Impact Velocity (ft/sec)	Impact Energy (ft-lb)	Impact Location	Dent Depth	Residual Strength (ksi)
AS4/3502 Laminate					
8 ply, (50/50/0)	100	10.20	Center	--	116.0, tension
8 ply, (50/50/0)	200	4.07	Center	--	103.0, tension
8 ply, (50/50/0)	300	9.15	Center	--	98.0, tension
8 ply, (50/50/0)	400	16.30	Center	--	105.0, tension
8 ply, (50/50/0)	200	4.07	0.75" off center	--	105.0, tension
8 ply, (50/50/0)	300	9.15	0.75" off center	--	91.0, tension
8 ply, (50/50/0)	400	16.30	0.75" off center	--	116.0, tension
9 ply, (0/89/11)	200	4.07	Center	--	27.2, tension
9 ply, (0/89/11)	300	9.15	Center	--	23.2, tension
9 ply, (0/89/11)	400	16.30	Center	--	22.6, tension
9 ply, (0/89/11)	200	4.07	0.75" off center	--	24.6, tension
9 ply, (0/89/11)	300	9.15	0.75" off center	--	16.8, tension
9 ply, (0/89/11)	400	16.30	0.75" off center	--	19.3, tension
8 ply, (50/50/0)	150	2.28	Center**		9.98, comp.
8 ply, (50/50/0)	150	2.28	4" off center**		9.10, comp.
9 ply, (0/89/11)	100	1.02	Center	--	20.2, comp.
9 ply, (0/89/11)	175	3.11	Center	--	20.7, comp.
9 ply, (0/89/11)	225	5.14	Center	--	27.8, comp
9 ply, (0/89/11)	250	6.35	Center	through	18.5, comp
9 ply, (0/89/11)	300	9.15	Center	through	18.8, comp
9 ply, (0/89/11)	350	12.40	Center	through	17.8, comp
9 ply, (0/89/11)	400	16.30	Center	through	19.2, comp.
9 ply, (0/89/11)	450	20.60	Center*	through	15.9, comp.
9 ply, (0/89/11)	100	1.02	0.75" off center	--	20.5, comp.
9 ply, (0/89/11)	175	3.11	0.75" off center	--	15.6, comp.
9 ply, (0/89/11)	250	6.35	0.75" off center	through	12.9, comp
9 ply, (0/89/11)	325	10.70	0.75" off center	through	15.6, comp.
9 ply, (0/89/11)	450	20.60	0.8" off center*	through	8.7, comp.
9 ply, (0/89/11)	450	20.60	1.2" off center*	through	8.7, comp.
24 ply, (50/50/0)	250	6.35	Center**	--	23.4, comp.
24 ply, (50/50/0)	250	6.35	3" off center**	--	21.8, comp.
24 ply, (50/50/0)	350	12.40	Center**	--	21.0, comp.
24 ply, (50/50/0)	350	12.40	3" off center**	--	21.6, comp
24 ply, (50/50/0)	350	12.40	4" off center**	--	16.2, comp.
24 ply, (50/50/0)	450	20.60	Center**	through	20.9, comp.

TABLE 4. SUMMARY OF TEST RESULTS IN REFERENCE 9 (Continued)

Layup	Impact Velocity (ft/sec)	Impact Energy (ft-lb)	Impact Location	Dent Depth	Residual Strength (ksi)
24 ply, (50/50/0)	450	20.60	3" off center**	through	21.2, comp.
24 ply, (50/50/0)	450	20.60	4" off center**	through	14.3, comp.
30 ply, (0/80/10)	100	1.02	Center	--	51.5, comp.
30 ply, (0/80/10)	175	3.11	Center	--	27.0, comp.
30 ply, (0/80/10)	250	6.35	Center	--	19.6, comp.
30 ply, (0/80/10)	325	10.70	Center	--	16.0, comp.
30 ply, (0/80/10)	400	16.30	Center	--	15.2, comp.
30 ply, (0/80/10)	540	29.50	Center	through	20.2, comp.
30 ply, (0/80/10)	500	25.40	Center*	--	21.0, comp.
30 ply, (0/80/10)	100	1.02	0.75" off center	--	50.7, comp.
30 ply, (0/80/10)	175	3.11	0.75" off center	--	29.0, comp.
30 ply, (0/80/10)	250	6.35	0.75" off center	--	22.7, comp.
30 ply, (0/80/10)	400	16.30	0.75" off center	--	15.5, comp.
30 ply, (0/80/10)	540	29.50	0.75" off center	through	17.0, comp.
30 ply, (0/80/10)	500	25.40	0.8" off center*		18.3, comp.
30 ply, (0/80/10)	500	25.40	0.8" off center*		18.3, comp.
30 ply, (0/80/10)	500	25.40	1.2" off center*		15.5, comp.
AS4/PEEK, tape, Laminate					
9 ply, (0/89/11)	100	1.02	Center	--	21.6, comp.
9 ply, (0/89/11)	100	1.02	0.75" off center	--	21.9, comp.
9 ply, (0/89/11)	175	3.11	Center	--	21.5, comp.
9 ply, (0/89/11)	175	3.11	0.75" off center	--	18.4, comp.
9 ply, (0/89/11)	250	6.35	Center	--	17.5, comp.
9 ply, (0/89/11)	250	6.35	0.75" off center	--	16.4, comp.
9 ply, (0/89/11)	300	9.15	Center	--	12.7, comp.
9 ply, (0/89/11)	325	10.70	Center	--	13.6, comp.
9 ply, (0/89/11)	325	10.70	0.75" off center	--	12.3, comp.
9 ply, (0/89/11)	350	12.40	Center	through	16.2, comp.
9 ply, (0/89/11)	400	16.30	Center	through	16.3, comp.
9 ply, (0/89/11)	400	16.30	0.75" off center	through	13.9, comp.
9 ply, (0/89/11)	500	25.40	Center	through	17.6, comp.
9 ply, (0/89/11)	450	20.60	Center*	through	18.2, comp.
9 ply, (0/89/11)	450	20.60	1.2" off center*	through	9.5, comp.
AS4/PEEK, fabric, Laminate					
9 ply, (0/89/11)	100	1.02	Center	--	22.9, comp.

TABLE 4. SUMMARY OF TEST RESULTS IN REFERENCE 9 (Continued)

Layup	Impact Velocity (ft/sec)	Impact Energy (ft-lb)	Impact Location	Dent Depth	Residual Strength (ksi)
9 ply, (0/89/11)	100	1.02	0.75" off center	--	23.8, comp.
9 ply, (0/89/11)	175	3.11	Center	--	23.7, comp.
9 ply, (0/89/11)	175	3.11	0.75" off center	--	22.0, comp.
9 ply, (0/89/11)	250	6.35	Center	--	19.1, comp.
9 ply, (0/89/11)	250	6.35	0.75" off center	--	17.8, comp.
9 ply, (0/89/11)	325	10.70	Center	through	17.8, comp.
9 ply, (0/89/11)	325	10.70	0.75" off center	through	14.8, comp.
9 ply, (0/89/11)	375	14.30	Center	through	16.5, comp.
9 ply, (0/89/11)	400	16.30	Center	through	18.2, comp.
9 ply, (0/89/11)	400	16.30	0.75" off center	through	13.6, comp.
9 ply, (0/89/11)	450	20.60	Center	through	18.1, comp.
9 ply, (0/89/11)	450	20.60	0.8" off center	through	13.8, comp.
9 ply, (0/89/11)	450	20.60	1.2" off center	through	12.2, comp.

Notes: All specimens impacted with 0.5-inch-diameter impactor.
 All specimens 3 inches wide by 10 inches long, except
 * 4 inches wide by 10 inches long.
 ** 14 inches wide by 10 inch long.

An experimental/analytical investigation was conducted in reference 10 to identify key impact parameters. Limited experimental data were presented in the reference for analytical correlation. The emphasis of this reference is in the methodology development and it will be discussed in more detail in the methodology review. The test results are not in terms of postimpact strength and therefore not summarized here.

A comprehensive investigation of the damage resistance characteristics of composite fuselage structure was conducted under the NASA Advanced Composites Technology program. Results of this study are given in references 11-13. This series of papers presents results of a statistical-based design of experiments to examine the roles of material, laminate, structural, and extrinsic (e.g., impactor parameters) variables on damage resistance. Even though there was no residual strength data generated under that investigation, the results are valuable in identifying key impact parameters. A detailed discussion of these results is presented below.

In references 11-13, the design of experiment (DOE) program considers fourteen variables in basically two groups, intrinsic and extrinsic. The intrinsic variables are structural and material variables and the extrinsic variables are impact variables. Two levels of each variable are considered in the study, namely high and low levels. The variables and their values are given in table 5.

TABLE 5. VARIABLES AND THEIR VALUES USED IN DOE [11-13]

Variable	High Value (H)	Low Value (L)
1. Fiber Type	IM7	AS4
2. Matrix Type	977-2	938
3. Fiber Volume	56.5%	48%
4. Material Form (Stiffener Layup)	Tape (Hard) ¹	Tow (Soft) ²
5. Skin Layup	Hard ³	Soft ⁴
6. Stiffener Type	Hat	Blade
7. Stiffener Spacing	12 in.	7 in.
8. Laminate Thickness	0.1776 in. (thick)	0.0888 in. (thin)
9. Impactor Stiffness	30 msi (steel)	0.4 msi (graphite/epoxy)
10. Impactor Mass	13.9 lbm	0.62 lbm
11. Impact Energy	1200 in-lb	200 in-lb
12. Impactor Shape	Spherical	Flat
13. Impactor Diameter	1.00 in.	0.25 in.
14. Temperature at Impact	180°F	70°F

- Notes: 1. Hard Stiffener (thin): (22.5/90/-22.5/0)_s; Hard Stiffener (thick): (22.5/90/-22.5/0)_{2s}.
 2. Soft Stiffener (thin): (30/90/-30/0)_s; Soft Stiffener (thick): (30/90/-30/0)_{2s}.
 3. Hard Skin (thin): (45/90/-45/0/90/0)_s; Hard Skin (thick): (45/90/-45/0/45/90/-45/0/90/0/90/0)_s.
 4. Soft Skin (thick): (45/90/-45/45/0/-45)_s; Soft Skin (thick): (45/90/-45/45/0/-45/-45/0/45/-45/90/45)_s.

A 32 run DOE test program was conducted in references 11-13. The test matrix was designed by a split-plot fractional factorial design to provide information on main variables and indicated variables interactions. All 32 specimens were three-stiffener panels. Boundary conditions that simulated circumferential frames were used in the test program. Each panel was impacted ten times with eight extrinsic variables and twice to simulate hail impact with 500-in-lb energy by 2.5-in.-diameter lead balls. Panels were impacted 3 in. from supports to simulate worst case condition. The results were measured in terms of dent depth, damage area, and fiber damage average length and thickness distribution.

The test results were analyzed during the course of the present study. The ranking of the impact parameters on the damage resistance is presented in tables 6 and 7. Table 6 shows the ranking of the intrinsic variable for the hail simulation impact tests. In these experiments, only the material and structural parameters are considered; the impact parameters are fixed. As shown in the table, the ranking based on two response measurements are not very consistent. However, the three top ranking parameters based on the two different responses are similar. Based on dent depth, the most significant parameters are laminate thickness, fiber volume ratio, and matrix type. From the results of the c-scan damage area, the most influencing parameters are matrix type, fiber volume ratio, and fiber type. Thus, one may conclude that the more significant material and structural parameters are the matrix type, fiber volume ratio, and maybe fiber type and laminate thickness.

TABLE 6. RANKING OF THE INTRINSIC VARIABLES FOR HAIL SIMULATION IMPACTS [11-13]

Variable	Rank by Dent Depth	Rank by Damage Area
1	5 (0.2543)	3 (0.4006)
2	3 (0.4162)	1 (0.7142)
3	2 (0.5462)	2 (0.5014)
4	8 (0.0853)	6 (0.2661)
5	4 (0.3717)	4 (0.3096)
6	6 (0.1727)	5 (0.2958)
7	7 (0.1532)	8 (0.4070)
8	1 (1.4546)	7 (0.1951)

Note: Number in () is the normalized ranking parameter with higher value corresponding to more significant effects.

TABLE 7. RANKING OF ALL IMPACT PARAMETERS IN THE FULL DOE [11-13]

Variable	Rank by Fiber Failure Length	Rank by Damage Area
1	7 (0.1387)	13 (0.1008)
2	14 (0.0253)	3 (0.6033)
3	9 (0.0975)	4 (0.3448)
4	8 (0.1365)	7 (0.2644)
5	12 (0.0493)	5 (0.2944)
6	11 (0.0630)	6 (0.2899)
7	10 (0.0794)	8 (0.2299)
8	3 (0.4534)	11 (0.1580)
9	13 (0.0263)	9 (0.1840)
10	6 (0.2933)	14 (0.0954)
11	1 (1.9448)	1 (1.4520)
12	4 (0.4267)	10 (0.1688)
13	2 (0.6014)	2 (0.7399)
14	5 (0.3990)	12 (0.1095)

Note: Number in () is the normalized ranking parameter with higher value corresponding to more significant effects.

Table 7 shows the ranking of all 14 parameters on the full DOE tests. The responses for these tests are fiber failure length and damage area. Again, the results shown in the table are not totally consistent. However, the significant parameters based on the ranking of the two responses are similar. Based on the results of the fiber failure length, the more significant parameters are impact energy, impactor diameter, and laminate thickness. The significant parameters based on the c-scan damage area are impact energy, impactor diameter, and matrix type. Notice that the results of the full DOE indicate that the impact parameters (extrinsic variables) have a more

significant effect on the damage, as shown in table 7. Not surprisingly, impact energy has a dominant effect on the resulting damage. The effect of impact energy, impactor diameter, matrix type, and laminate thickness on the fiber failure length and the c-scan damage area are shown in figures 1 through 8. Each bar in these figures represent a result of one test for a total of 32 tests. When there is no measurable damage a bar is absent at the given location. Thus, for example in figure 1 low-impact energy does not result in significant fiber breakage. The effects of these variables on the maximum impact force, the local flexural stiffness, the local core damage area, and the stiffener flange separation were also investigated in references 11-13. The results consistently show the above parameters dominated the impact responses.

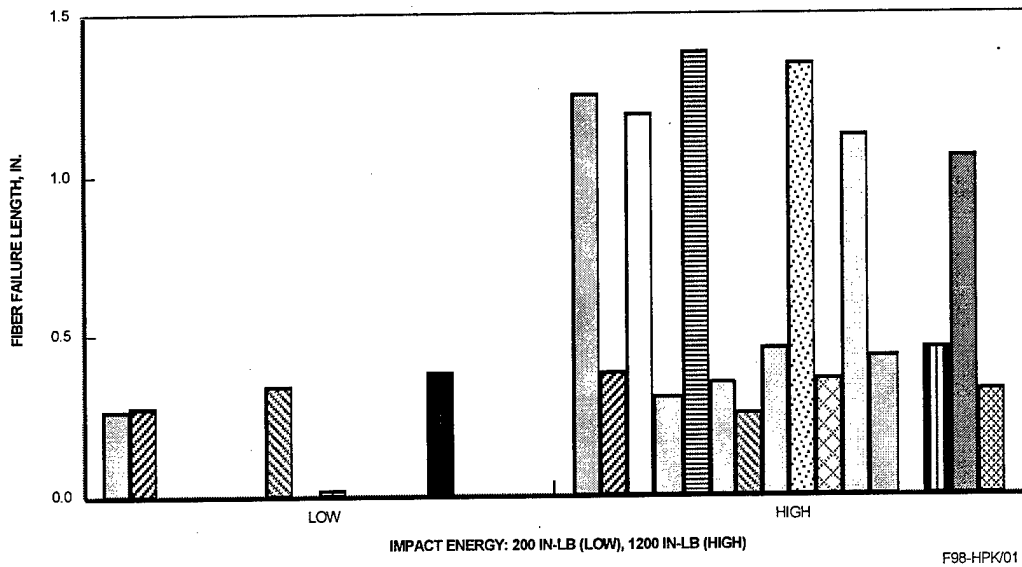

FIGURE 1. EFFECTS OF TYPICAL IMPACT ENERGY ON FIBER FAILURE LENGTH, RANK 1/14

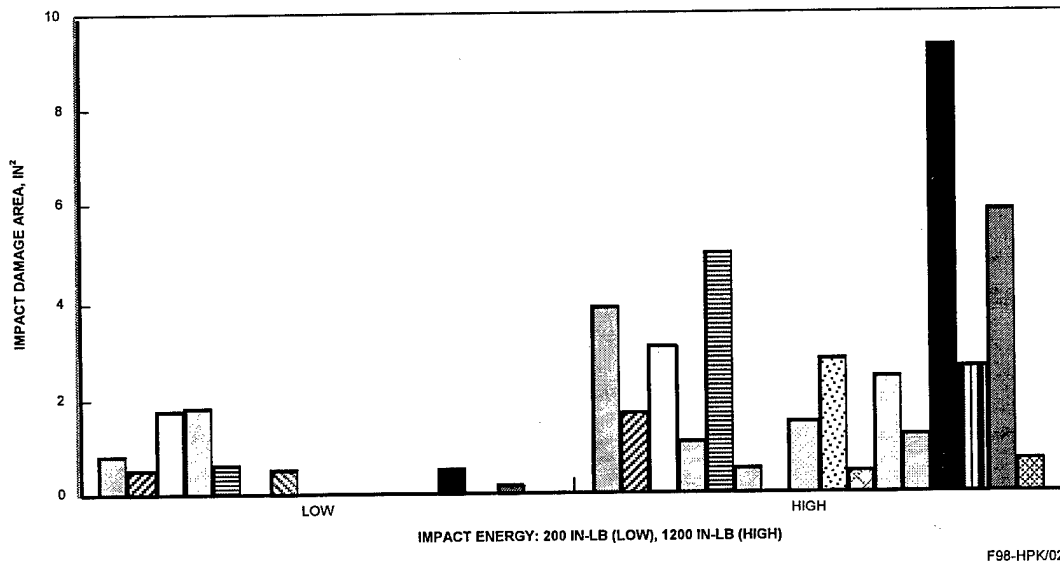

FIGURE 2. EFFECTS OF IMPACT ENERGY ON DAMAGE AREA, RANK 1/14

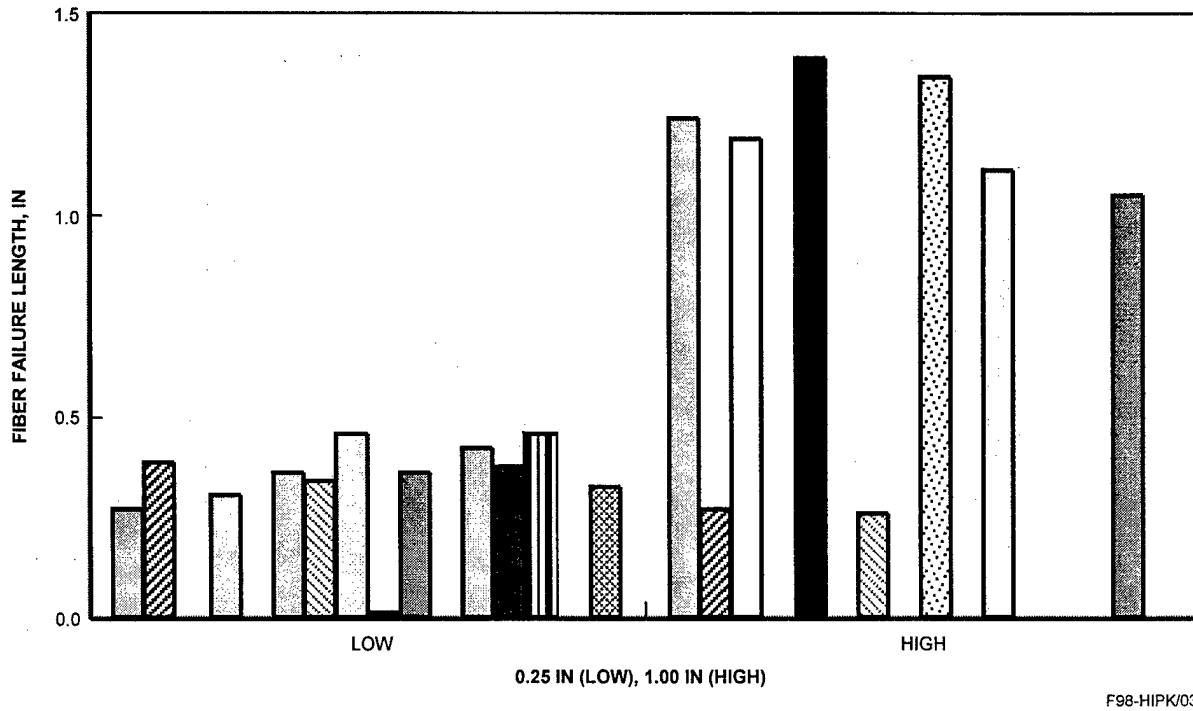

FIGURE 3. EFFECTS OF IMPACTOR DIAMETER ON FIBER FAILURE LENGTH, RANK 2/14

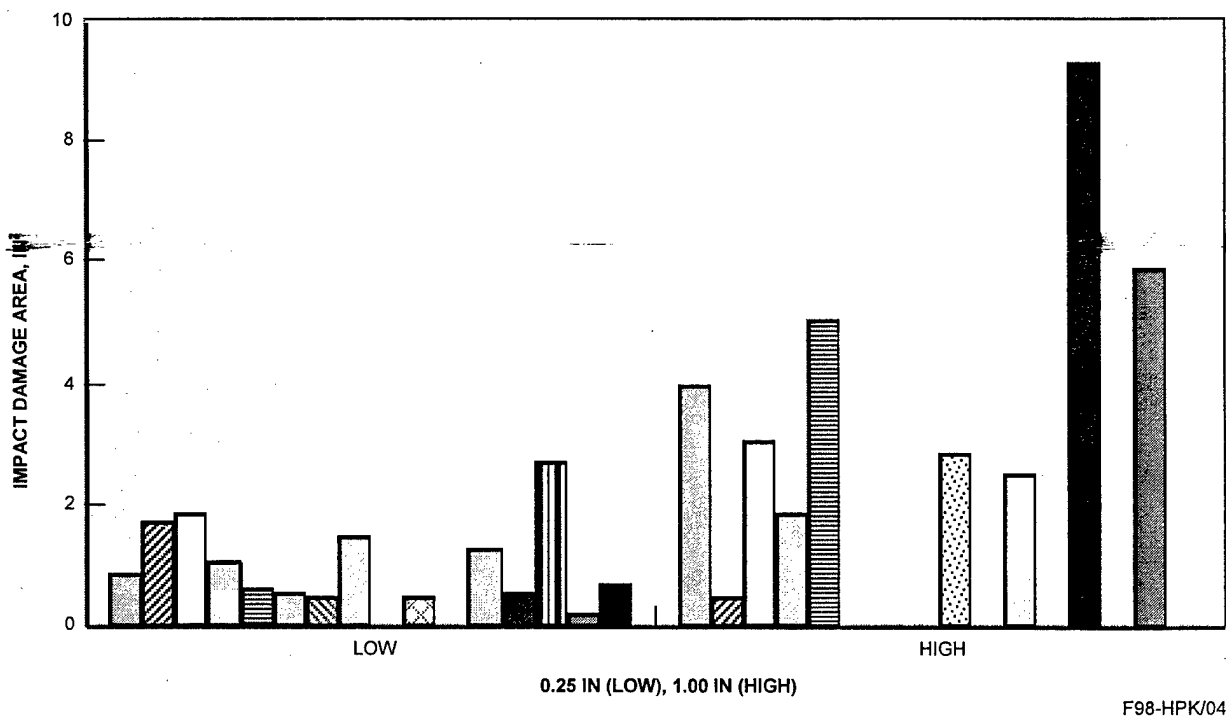

FIGURE 4. EFFECTS OF IMPACTOR DIAMETER ON DAMAGE AREA, RANK 2/14

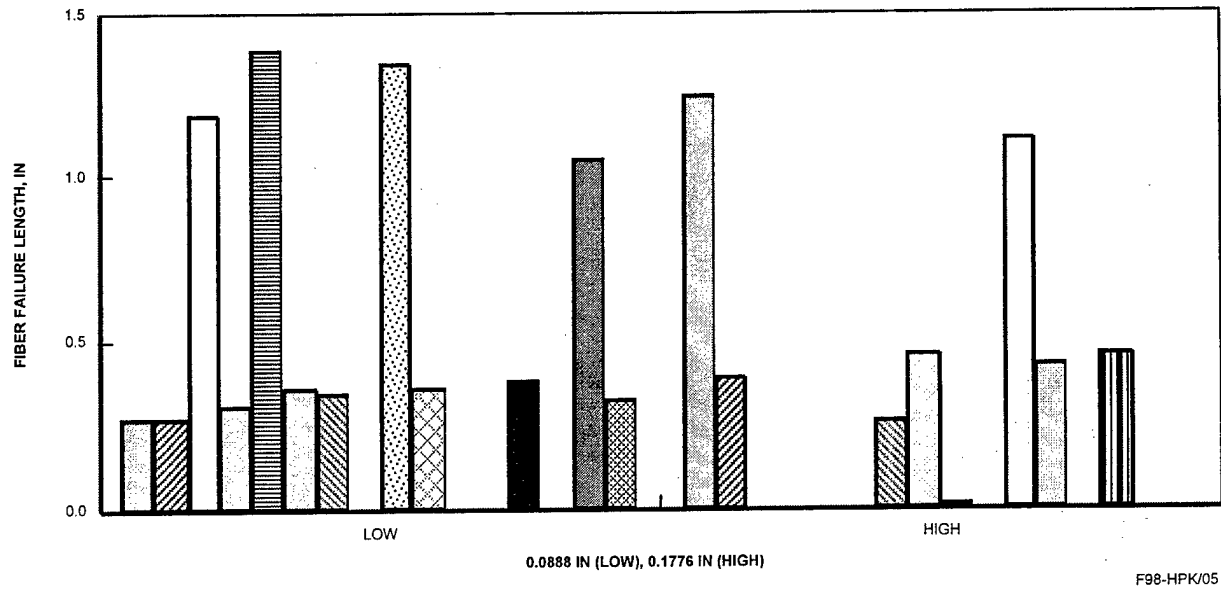

FIGURE 5. EFFECTS OF LAMINATE THICKNESS ON FIBER FAILURE LENGTH, RANK 3/14

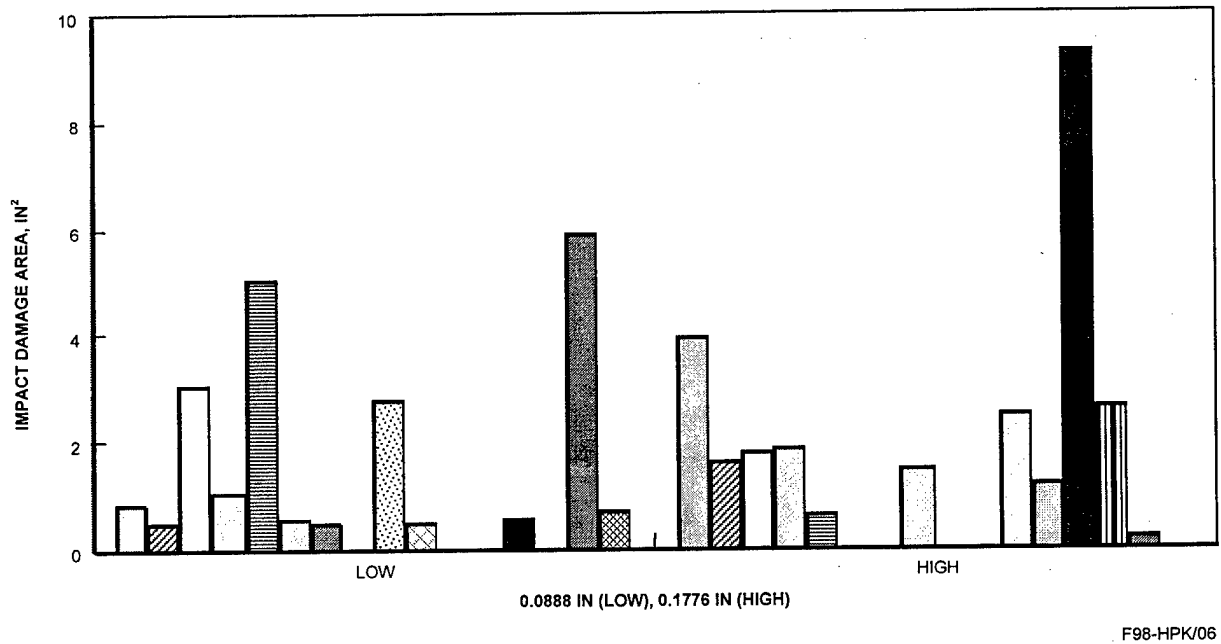

FIGURE 6. EFFECTS OF LAMINATE THICKNESS ON DAMAGE AREA, RANK 11/14

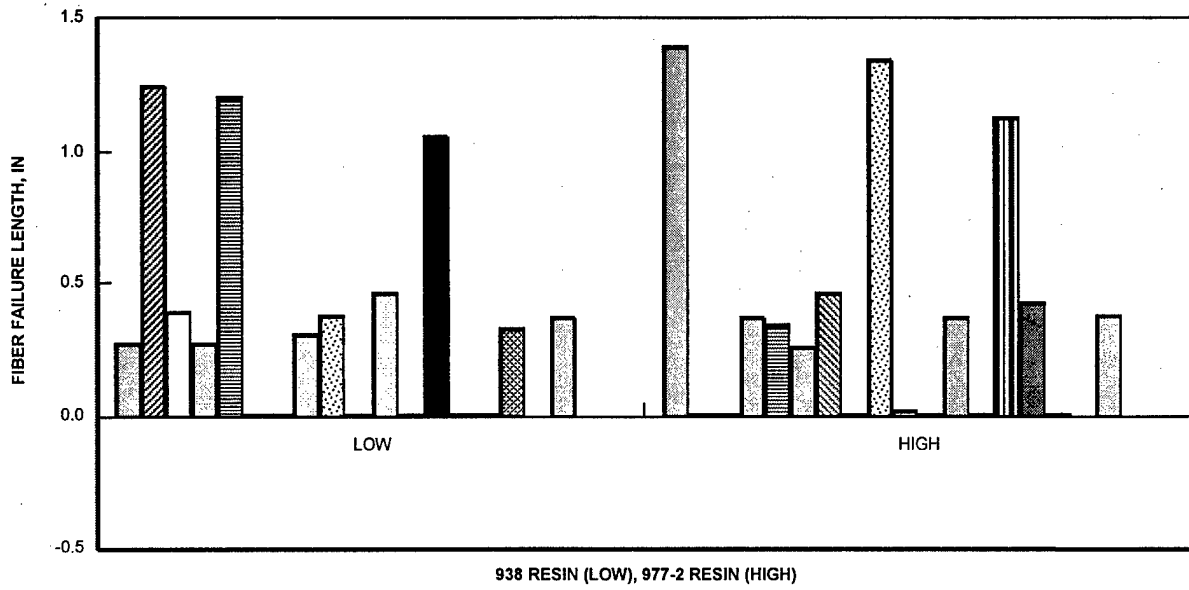

FIGURE 7. EFFECTS OF MATRIX TYPE ON FIBER FAILURE LENGTH, RANK 14/14

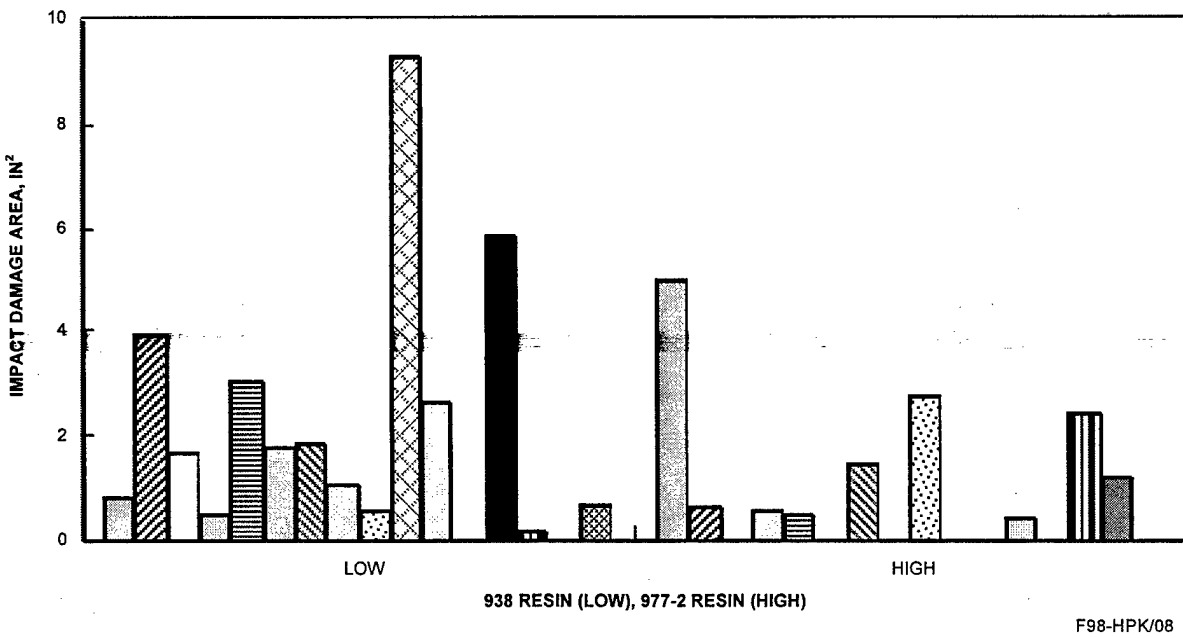

FIGURE 8. EFFECTS OF MATRIX TYPE ON IMPACT AREA, RANK 3/14

The effect of the variable interaction on the impact responses is another objective in the study of references 11-13. The results of the same DOE tests were used to analyze these effects. The ranking of the interactions are summarized in table 8. The results can also be shown graphically. Typical interaction charts of the most significant variables are shown in figures 9 and 10. In

TABLE 8. RANKING OF TWO-VARIABLE INTERACTION ON THE IMPACT DAMAGE RESISTANCE [11-13]

Rank	By Fiber Failure Length	By Damage Area
1	1/7, 2/6, 3/9, 4/5, 10/14, 11/13	1/7, 2/6, 3/9, 4/5, 10/14, 11/13
2	1/9, 2/5, 3/7, 4/6, 8/13, 10/12	1/11, 3/8, 4/10, 5/14, 6/12, 7/13
3	1/2, 3/4, 5/9, 6/7, 8/10, 12/13,	1/10, 2/8, 4/11, 5/13, 7/14, 9/12
4	1/4, 2/3, 5/7, 6/9, 8/14, 10/11, 13/14	2/11, 3/10, 4/8, 6/13, 7/12, 9/14
5	1/6, 2/7, 3/5, 4/9, 11/12	1/12, 2/13, 3/14, 5/8, 6/11, 9/10
6	1/5, 2/9, 3/6, 4/7, 8/12, 10/13, 11/14	1/13, 2/12, 4/14, 5/10, 7/11, 8/9
7	2/11, 3/10, 4/8, 6/13, 7/12, 9/14	1/6, 2/7, 3/5, 4/9, 8/14, 11/12
8	1/3, 1/13, 2/4, 2/12, 4/14, 5/6, 5/10, 7/9, 7/11, 8/9, 8/11, 12/14	1/14, 3/12, 4/13, 5/11, 6/8, 7/10
9	1/12, 2/13, 3/14, 5/8, 6/11, 9/10	2/14, 3/13, 4/12, 6/10, 7/8, 9/11
10	1/8, 2/10, 3/11, 5/12, 6/14, 9/13	1/8, 2/10, 3/11, 5/12, 6/14, 9/13
11	1/14, 3/12, 4/13, 5/11, 6/8, 7/10	1/2, 3/4, 5/9, 6/7, 8/10, 12/13
12	2/14, 3/13, 4/12, 6/10, 7/8, 9/11	1/9, 2/5, 3/7, 4/6, 8/13, 10/12
13	1/10, 2/8, 4/11, 5/13, 9/12	1/5, 2/9, 3/6, 4/7, 8/12, 10/13, 11/14
14	1/11, 3/8, 4/10, 5/14, 6/12	1/4, 2/3, 5/7, 6/9, 10/11, 13/14
15		1/3, 2/4, 5/6, 7/9, 8/11, 12/14

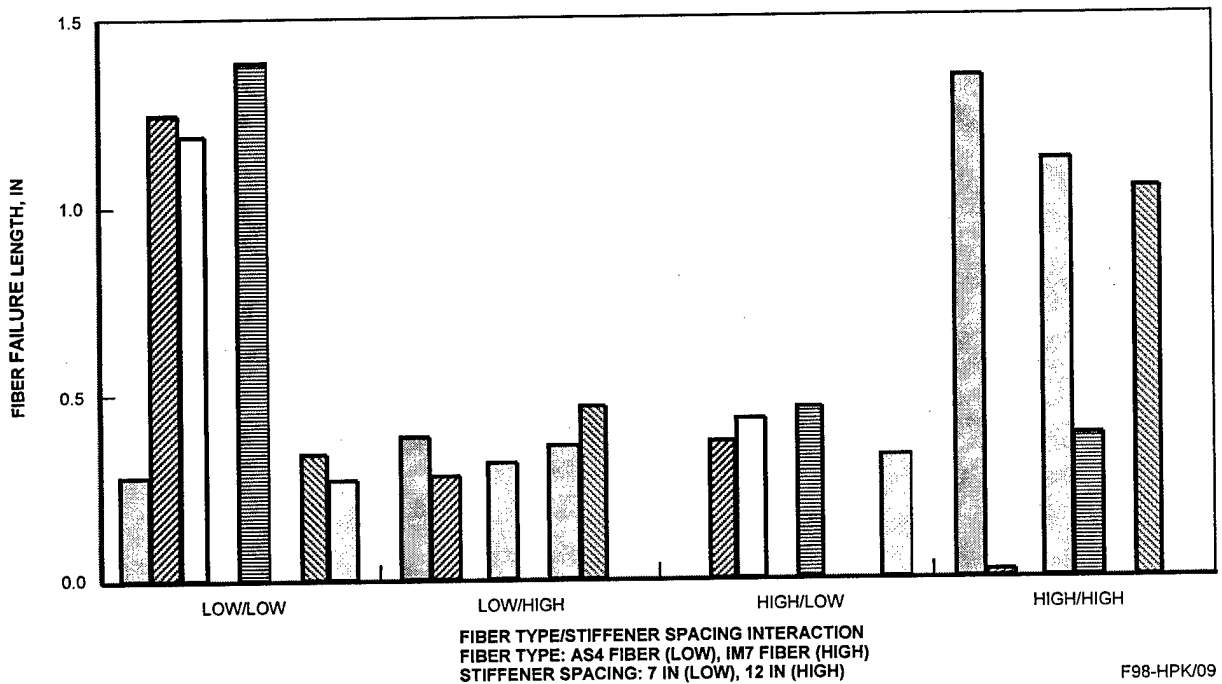
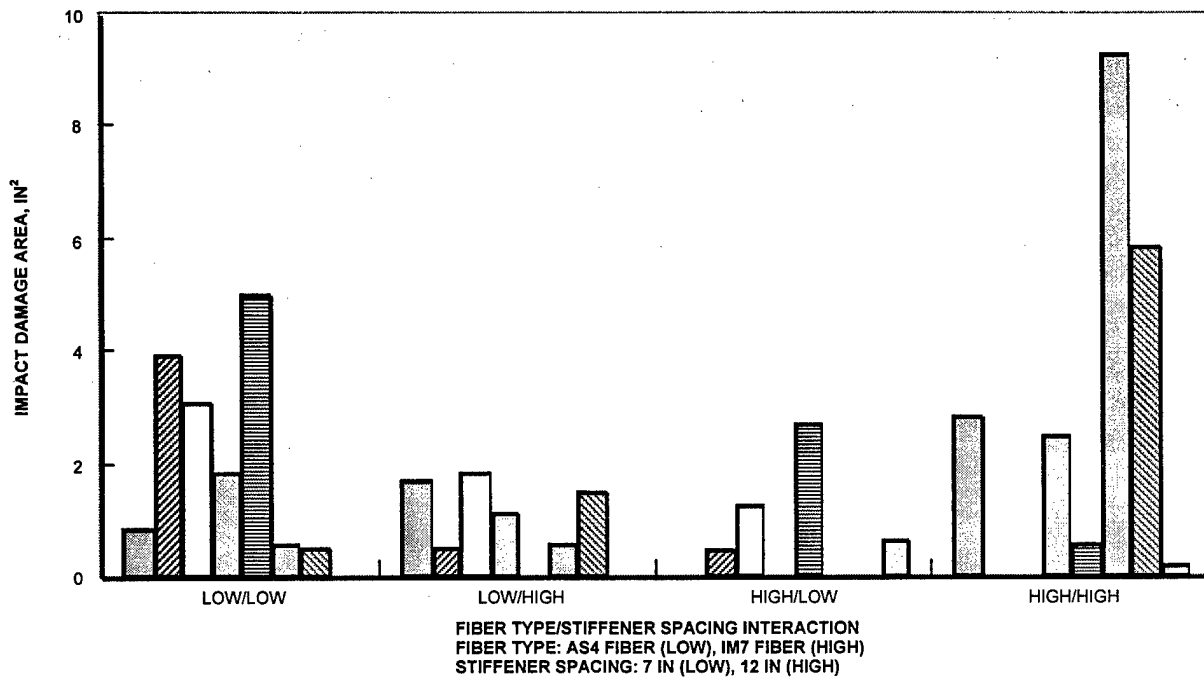

FIGURE 9. FIBER TYPE/STIFFENER SPACING INTERACTION ON FIBER FAILURE LENGTH



F98-HPK/10

FIGURE 10. FIBER TYPE/STIFFENER SPACING INTERACTION ON IMPACT DAMAGE AREA

these figures, the strong interaction is illustrated by significant difference in response (fiber failure length in figure 9 and impact damage area in figure 10) between similar level tests (HH and LL) and mixed level tests (HL and LH) of the variables. Table 8 shows that the most significant two-variable interactions for both damage types are identical. They are

- 1/7 or fiber type and stiffener spacing interaction
- 2/6 or matrix type and stiffener type interaction
- 3/9 or fiber volume and impactor stiffness interaction
- 4/5 or stiffener layup and skin layup interaction
- 10/14 or impactor mass and temperature interaction
- 11/13 or impact energy and impactor diameter interaction

Reference 14 reported experimental data on improved toughness epoxy composites, HTA/R6376. The impact damage in this reference was simulated by quasi-static indentation. The effects of in-plane preload and boundary conditions on the simulated impact damage were evaluated in the reference. The results of this study indicate no significant difference in damage for the improved toughness epoxy. An interesting observation from this study was that the c-scan damaged area increased with energy until it was approximately 0.23 sq. in. (150 sq. mm). Further increases in energy produced additional damage within the damage area but the area itself did not increase. The results also showed that there was no indentation rate effect on damage for panels under stress.

An experimental investigation was conducted in reference 15 to evaluate the response, including damage, of composite shell structures to transverse loading in impact and quasi-static tests and to establish the differences between convex shell and plate response. Because of the structural configuration involved in the study, the impact response was complicated by the local stability of the specimens. Details of these test data will not be discussed here. Observations not related to the structural configurations are that the quasi-static response and the impact response (including damage) were equivalent. Also, the average damage extent for a convex shell was found to scale nearly linearly over a large range of peak forces (below approximately 1500 N or 340 lbf). All specimens exhibited a damage threshold force of approximately 400 N (90 lbf).

Reference 16 presents the general damage tolerance and durability requirements for the F/A 18E/F aircraft. In addition to the requirements that are equivalent to that of the FAA's, it provides details in planning low-velocity impact damage (LVID) tests to obtain design allowables for certain structural details.

In summary, the experimental data generated in the last 10 years are mostly concentrated in special applications. This type of data is not suitable for general prediction model development. Also, the impact research has emphasized the division between damage resistance and damage tolerance. From a pure research point of view, in the long run, this trend contributes to the basic understanding of the composite materials and structures response to low-velocity impact. However, an engineering tool is needed for the damage tolerance evaluations of composite structures in order to relieve the need for extensive structural testing. The technology assessment conducted under the present program also found that impact data have been generated for a variety of material forms (fabrics, sandwich constructions, stitched laminates, etc.) on different structural configurations and under different type of loads.

2.2 ANALYSIS METHODS.

Impact analysis methods development during the last 10 years can be classified into three categories: (1) impact simulation, (2) impact parameter identification, and (3) empirical methods. A majority of these methods are discussed in the review articles, references 2-5. Only the later developments are highlighted in the assessment below.

An energy balance approach was adopted in reference 7 to analyze the stitched laminate data. The important impact parameters identified in the reference are the shape of the contact region under the impactor and the kinetic energy of the impactor. The resulting shear force and the axial and bending forces due to impact forces were found to be dependent upon the stiffness of the impact site and how the impact force is reacted, the boundary conditions, and the dynamic effects. The impact force was predicted by separating the kinetic energy into the elastic energy and the Hertzian contact energy as

$$KE = \int_0^{\delta_{\max}} Pn_1(\delta_1) d\delta + \int_0^{\delta_{\max}} Pn_h(\delta_h) d\delta \quad (1)$$

where P_n is the impact force. The maximum impact force can be predicted from equation 1. The internal stresses due to impact force (bending, compression, and shear) can also be computed. To predict the compression strength after impact, the reference further defines an impact force parameter, Potential Damaging Force (PDF) as

$$PDF = P_{ncacl_{max}} / t^n \quad (2)$$

where t is the skin thickness, n is a fit parameter with $n=2$ best fit for the residual compression strength, and $P_{ncacl_{max}}$ is the predicted maximum impact force. Excellent correlation was found between PDF and relative dent depth for the majority of the data.

Based on extensive static simulation and dynamic impact data, reference 10 proposed a methodology for impact data correlation. In this methodology, the impact parameters were first identified. The reference concluded that impact energy may be used as an impact parameter only when the mass of the impactor is large and the plates are small and have the same transverse stiffness. Impact force is used as an impact parameter when the plate boundaries are remote from the extent of the damage. Damage measurements, such as dent depth, can be used as impact parameters for residual strength consideration when the effects of the impactor shape and laminate thickness are quantified.

The impact responses were simulated analytically in reference 10. These simulations included impact force, transverse shear force, and maximum delamination diameter. At a given impact energy, the peak impact force was expressed in terms of the impactor mass. The impact force curve was divided into three regions: static (large mass), transitional, and dynamic (small mass). For large mass, the energy balance method predicted the impact force accurately. For large-mass impact, the impact force was affected by the plate boundaries; however, for small mass, the impact force was independent of boundary conditions and plate size.

The transverse shear force history was calculated and normalized by the static shear force for the peak contact force and expressed as a function of the reciprocal of the impactor mass in reference 10. For large masses, a static analysis, equation 3, was adequate to obtain transverse shear force. However, for a large plate, dynamic shear force was significantly higher than static even in the large mass region.

$$V = \frac{F}{2\pi r} \quad (3)$$

The maximum delamination diameter was computed by the energy balance method in reference 10. For constant energy, the impact force, and hence maximum delamination (damage) diameter, depended strongly on plate size, thickness, and boundary conditions for large-mass impact.

Using the Hertzian contact law and the Conway and Greszezuk formulation in cylindrical coordinate system, reference 17 developed a prediction methodology for impact simulation and residual strength analysis for textile composites. A test program was also conducted to verify the analytical prediction. The types of damage considered in the reference are matrix cracks,

delaminations, and fiber breakage. Three failure criteria for the different damage mechanisms were used in the prediction models. The prediction methodology was divided into damage prediction and residual strength prediction. The residual strength model was a progressive strength analysis procedure.

The impact responses of cylindrically curved composite panels was investigated analytically using the finite element method in reference 18. A modified Hertzian contact law was considered. In the finite element simulation, the contact force was obtained by integrating the contact stress over the contact boundary. It was found in the reference that Hertzian law results are layup independent for a material. However, the finite element result showed that the force is layup dependent. Also, the modified Hertzian law underestimated the contact force for a given indentation because of the imbedded infinite half-space assumption.

In reference 19, a static simulation of low-velocity impact on sandwich construction with composite facesheets and a honeycomb core was analytically conducted. The loading system was divided into two parts. An antisymmetrical component was used to simulate the panel bending deflection, including the effects of core shear and flatwise stiffness, and a symmetrical component was used to simulate the core dent. The results showed potential application of the method to simulate impact damage in sandwich structures. A global-local approach was presented in reference 20 to compute the interlaminar stresses. This approach used a two-dimensional finite element method for global analysis to provide boundary traction for a local model. Local solution domain was divided into two regions, with different thicknesses. Independent solutions were developed for the two regions, and the interregion continuity conditions from variational statement were used to connect the two solutions. This analysis also has the potential for application in postimpact strength prediction.

In summary, improved analytical methods, in both damage resistance and damage tolerance, have been developed in the last 10 years. However, similar to the experimental development, a considerable amount of research is still needed to provide an engineering tool for damage tolerance evaluation of composite structures.

In the technology assessment conducted under this program, attempts were also made to identify experimental data that are suitable for statistical characterization of impact damage and postimpact strength. Even though data scatter was observed, especially in the damage resistance data, such as damage area and dent depth, there is insufficient data for statistical consideration.

3. ANALYTICAL METHOD DEVELOPMENT.

The technology assessment conducted under the present program suggested that, from both the experimental data and analysis methods point of view, an empirical method that bridges the damage resistance and damage tolerance resulted from low-velocity impact of composites will provide an engineering tool for a damage tolerance certification methodology of composite structures. As a result of this assessment, the semiempirical method developed in references 1 and 2 was selected for further development. This baseline method is briefly summarized below and the modification of the approach is discussed in detail in section 3.2.

3.1 STIFFNESS REDUCTION MODEL.

The semiempirical method developed in references 1 and 2 is based on an elastic stiffness reduction technique. In this approach, the damage resistance of a composite structure is modeled using a region of reduced elastic stiffness, as shown in figure 11. The localized stiffness reduction causes a stress concentration effect, which determines the damage tolerance capability of the structure. However, because of the complexity of the damage state and the degree of difficulty of damage mechanics, a semiempirical approach is adopted. In addition, the model takes a one-step approach so that damage resistance and damage tolerance and any possible interaction can be addressed together.

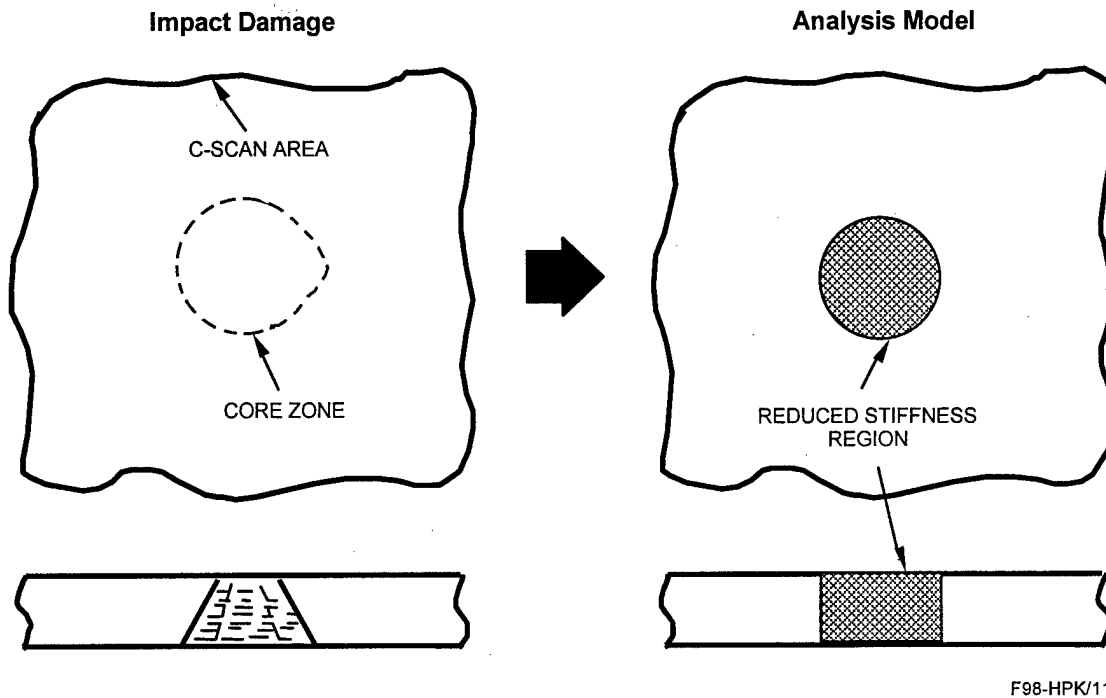

FIGURE 11. STIFFNESS REDUCTION MODEL

The baseline model for impact response of composite laminate was modified in reference 1 to incorporate the structural configuration effects. The model was further modified in reference 2 to address the data scatter issue in the reliability prediction of impact damaged structures. The baseline model, the structural configuration effects, and the reliability predictions are briefly summarized in the following paragraphs.

3.1.1 Baseline Model.

The first step in the development of a semiempirical model is to identify the important parameters that significantly affect the impact damage resistance and the resulting damage tolerance of a composite structure. In the stiffness reduction model, these parameters can be classified into three categories:

- a. Impact threat parameters, which include impact energy and impactor size. The model assumes that the severity of stiffness reduction, for a given material system and impact condition, depends on the impact energy.
- b. Material parameters, which include strength of the undamaged laminate, fracture toughness of the material system (G_{IC}), laminate thickness, and laminate layup.
- c. Structural parameters, which include boundary conditions and substructural configurations.

In the model, the empirical relationship between the postimpact compression strength and the impact parameters was obtained from extensive data correlation. The failure stress is expressed as

$$\sigma_f = \sigma_0 / [1 + C_1 C_2 C_3 C_4 C_5 W_e] \quad (4)$$

where σ_f is the failure stress of the impact damaged laminate,
 σ_0 is the failure stress of the undamaged laminate,
 C_1 is a laminate layup parameter,
 C_2 is the full-penetration stress concentration parameter,
 C_3 is the laminate thickness parameter,
 C_4 is the material toughness parameter,
 C_5 is the impact energy parameter, and
 W_e is the impactor size parameter.

Empirical expressions for the parameters were obtained in algebraic expressions and they are summarized below.

$$C_1 = 0.547(E_x / E_L)^{0.524} \quad (5)$$

$$C_2 = 3.707 \quad (6)$$

$$C_3 = 0.499 / t^{0.5056} \quad (7)$$

$$C_4 C_5 = A(kE)^B \quad (8)$$

$$A = 0.749 / G_{IC} + 0.0145 \quad (9)$$

$$\begin{aligned} B &= 0.4345 + 0.109G_{IC} - 0.0098G_{IC}^2 && \text{for } G_{IC} \leq 5.55 \\ B &= 0.737 && \text{for } G_{IC} > 5.55 \end{aligned} \quad (10)$$

$$W_e = \frac{2 + (1 - D/W)^3}{1 - D/W} \quad (11)$$

where E_X is the Young's modulus of the laminate in the loading direction,
 E_L is the longitudinal Young's modulus of the lamina,
 t is the laminate thickness,
 G_{IC} is the Mode I fracture toughness of the material system, and
 k is the support condition coefficient.

Coefficient k is added in equation 8 to account for the support condition effects. This coefficient is an indicator for the amount of energy consumed in damage creation under an impact event. A value of 1.0 is used for midbay impact of a stiffened panel.

3.1.2 Structural Configuration Effects.

The overall postimpact strength of a built-up composite structure is significantly influenced by the structural configuration. Based on the experimental data developed in reference 1, the structural configuration effects were incorporated into the baseline stiffness reduction model. It was observed from the residual strength tests of impact damaged stiffened composite panels that in most cases failure was in two stages: initial or local failure and final or structural failure. At the initial failure, the damage propagated to the stiffeners. The damage was arrested by the stiffeners and final failure took place at a higher applied load.

In the original model, the impact damage was assumed to act as a slit after the initial failure and damage propagation was arrested by the stiffeners, as shown in figure 12. Stress or strain at initial failure was determined by using the baseline model. After the initial failure, the damaged bay was assumed to be totally ineffective, with the slit causing stress (strain) concentration in the adjacent bays. From this assumption, the overall equilibrium of the structure requires

$$P_{TOT} = P_{sp} + P_1 + P_2 + P_3 \quad (12)$$

where: P_{TOT} is the total applied load,
 P_{sp} is the amount of load carried by the stiffeners,
 P_1 is the amount of load carried by the adjacent partial bay,
 P_2 is the amount of load carried by the adjacent full bay, and
 P_3 is the amount of load carried by the remote partial bay.

The load distribution (P_1, P_2, P_3) is obtained by integrating the stresses along the x axis in figure 12 with the stress distribution empirically determined from test data. Final failure is then predicted using an average stress (strain) criterion, similar to that used for strength prediction of laminates with an open or loaded hole [21]. The influence of impact location (midbay, stiffener edge, or over stiffener) on postimpact strength is accounted for by using the support coefficient k , as indicated in equation 8.

The final failure stress (strain) predicted by this method is then compared to the initial failure stress (strain) predicted by the baseline model. If the initial failure stress (strain) is larger than the final failure stress (strain), damage propagation will not be arrested by the substructure, and the initial failure strength coincides with the final structural strength. If the final failure stress (strain) is larger than the initial failure stress (strain), the failure is a two-stage failure; that is, the initial unstable propagation of the damage will be arrested by the substructure. Thus, final failure will occur at a higher applied load.

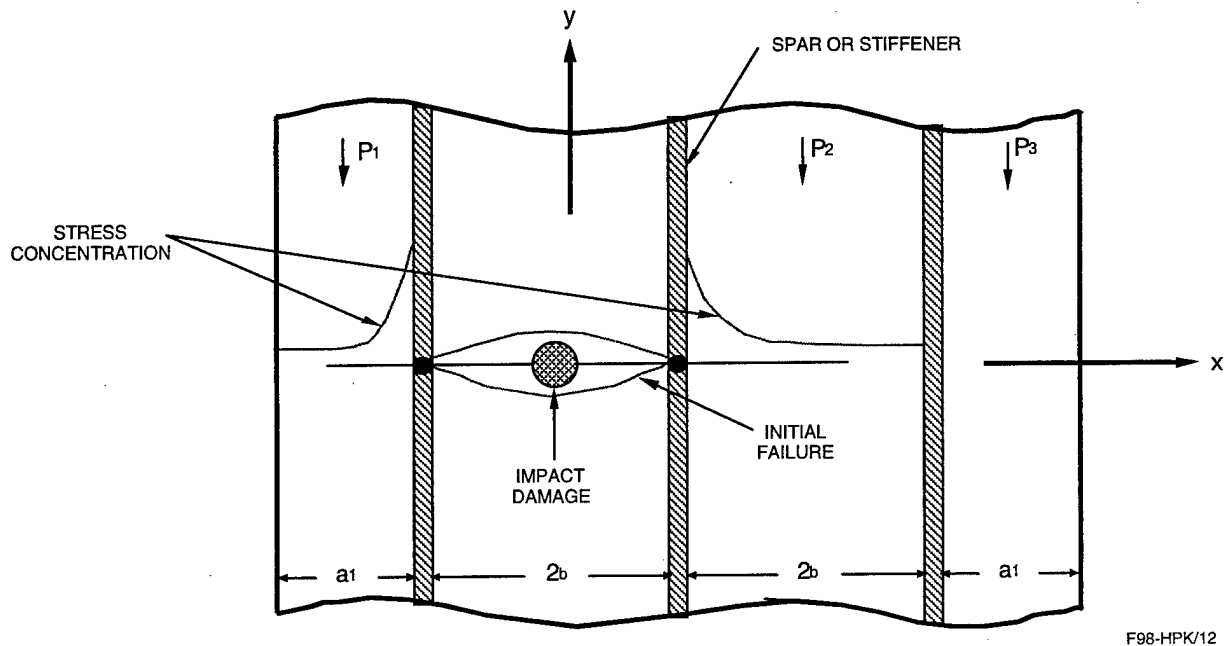

FIGURE 12. STRUCTURAL CONFIGURATION EFFECTS

3.1.3 Reliability Analysis.

An integrated analysis methodology was developed in reference 2 to estimate the reliability of composite structure under a given impact threat.

The key parameters that affect the structural reliability were first identified in reference 2, and they were then integrated with the strength prediction model to perform reliability assessment. The parameters identified are (1) variability of the undamaged laminate strength; (2) variability of damaged laminate strength, that includes scatter in damage size, shape and location, and the scatter in the postimpact strength; and (3) the likelihood of the structure having been impacted during the service life of the structure or the probabilistic distribution of impact threat.

The integrated analysis procedure is schematically shown in figure 13. Figure 13(a) shows the relationship between the postimpact strength and the impact energy. Also shown in figure 13(a) is the postimpact strength data scatter at different energy levels. The stiffness reduction discussed above is employed to establish the relation between the postimpact strength and the

impact energy. A two-parameter Weibull distribution is used to describe the scatter of the strength. In figure 13(b), the impact threat distribution is shown as a Weibull distribution. The postimpact strength and the impact threat are combined to form a compounded distribution to determine the impact damage tolerance strength reliability at a given applied stress (strain), as shown in figure 13(c).

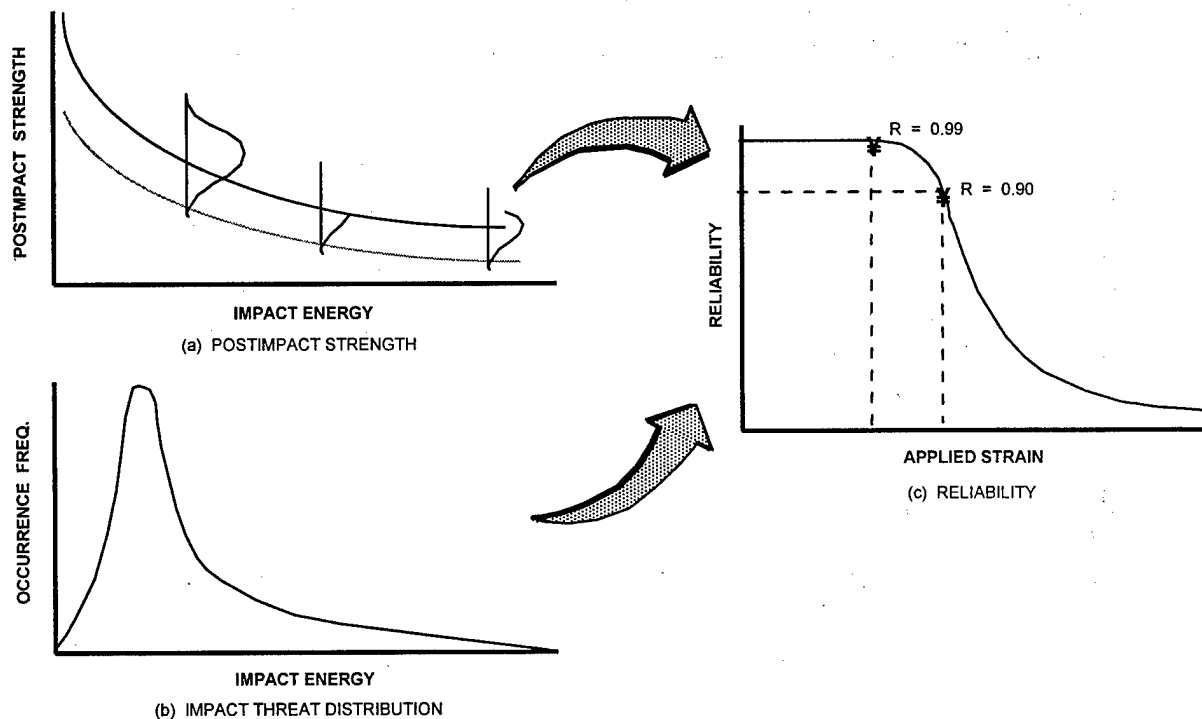

F98-HPK/13

FIGURE 13. SCHEMATIC OF THE INTEGRATED RELIABILITY ANALYSIS METHODS

The probabilistic impact threat imposed on an aircraft structure depends on the location of the structure on the aircraft and on the sources of the in-service impact. In order to establish a realistic impact damage requirement, a structural zoning procedure should be used to categorize the structure. Based on the available data, reference 2 defined three levels of impact threat for composite aircraft structures. The Weibull parameters of these threats are summarized in table 9 and the probabilistic densities are shown in figure 14. As discussed in reference 2, these threats are, in general, conservative as compared to the limited in-service survey data.

As it was stated in the technology assessment task, very limited test data are available to statistically characterize the postimpact strength. The scatter analysis conducted in reference 2 still provides the most useful statistics for reliability assessment. Based on the results of reference 2, the Weibull scatter parameter $\alpha = 12.0$ will again be used as the baseline scatter parameter.

TABLE 9. WEIBULL PARAMETERS FOR THE PROBABILISTIC IMPACT THREATS

	High Energy	Medium Energy	Low Energy
Modal Impact Energy, X_m (ft-lb)	15	6	4
Probability at 100 ft-lb, $p(100)$	0.1	0.01	0.0001
Weibull Scatter Parameter, α	1.264	1.192	1.221
Weibull Scale Parameter, β (ft-lb)	51.7	27.8	16.2

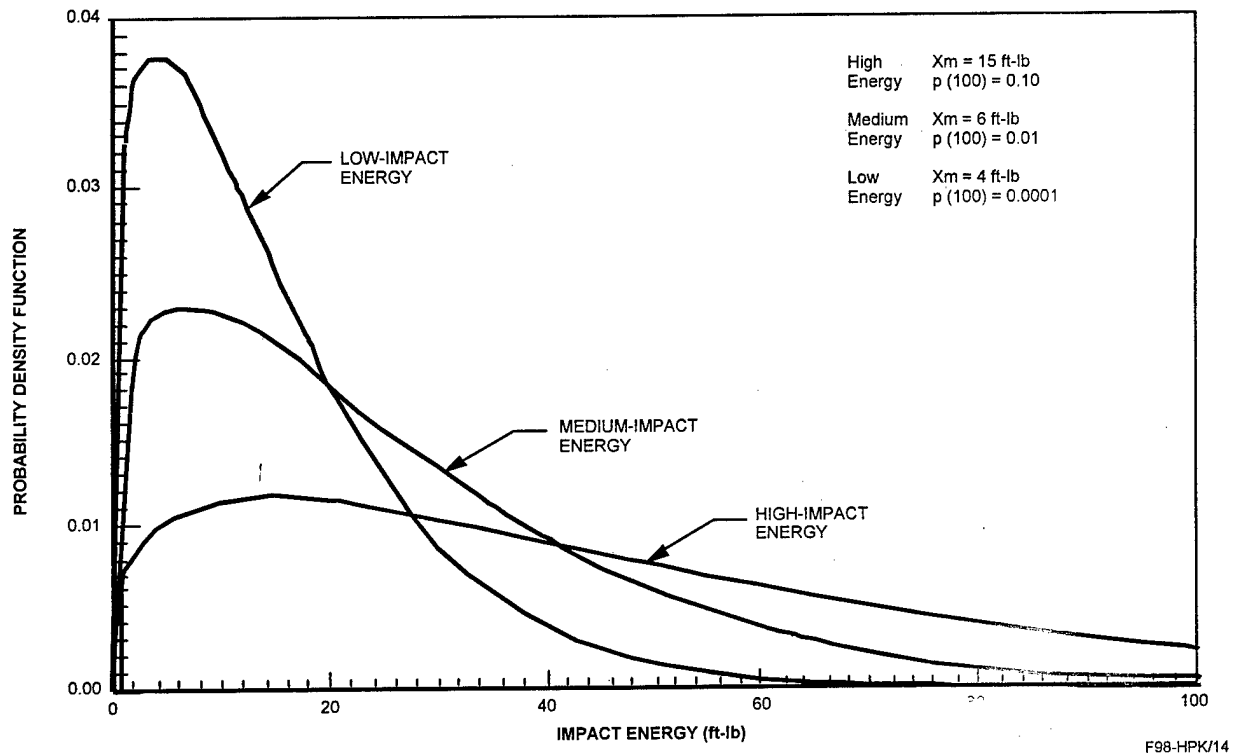

FIGURE 14. PROBABILITY DISTRIBUTION OF IMPACT THREATS

The postimpact probability of survival of a structure under an applied strain ϵ is defined as $p(\epsilon)$. This probability is dependent upon the impact energy and the postimpact strength scatter in addition to the impact parameters discussed earlier. The probability of occurrence at energy level E under a given impact threat is denoted by $P(E)$. By integrating $p(\epsilon)$ and $P(E)$ over the entire range of impact energies the impact damage strength reliability is then given by the joint probability function

$$R(\epsilon) = \int p(\epsilon)P(E)dE \quad (13)$$

The reliability $R(\epsilon)$ in equation 13 was evaluated using a numerical integration scheme. The numerical integration will be used in the present program.

3.2 MODEL MODIFICATION.

The stiffness reduction model and the reliability analysis method discussed above were modified under the present effort. The modification was primarily in reducing the empirical constants required in the baseline as well as the structural models. Attempts were also made to characterize the probabilistic distributions, based on the results of the technology assessment, in the reliability computations. In addition, a cutoff energy level and a threshold energy level were also established analytically for the strength prediction. These modifications are discussed in the following paragraphs.

3.2.1 Energy Level Effects.

The basic interaction effect between the impact energy and the fracture toughness of the material system used in the baseline model was not modified. However, the experimental data reviewed during the technology assessment task suggested that there is a cutoff energy and a threshold energy. These energy levels were incorporated into the stiffness reduction model. The cutoff energy level is determined based on the through penetration impact. For impact energy that exceeds the cutoff level, the residual strength is given by the open hole strength, which is determined by the average stress criterion. The hole diameter at cutoff energy is $D+6t$, where D is the impactor diameter, and t is the laminate thickness. This hole diameter is based on the damage area measured by c-scan, and also confirmed by the core damage area observed. In addition, a cutoff impact energy level is used for the residual strength degradation. The cutoff energy for residual strength is twice the energy for a through penetration. Between the penetration cutoff and the residual strength cutoff, the damage diameter increased by an amount of $1.0/G_{IC}$. The threshold energy, below which no strength reduction is caused by the impact, is 0.1 of the penetration cutoff energy or 20 ft-lb, whichever is smaller.

The effects of the cutoff and threshold energies on the postimpact compression strength are shown in figures 15 and 16. Both figures show results for laminates with a (42/50/8) layup. The laminate used for figure 15 is 48 plies thick, and the laminate used for figure 16 is 24 plies thick. The composite material is AS4/3501-6 graphite/epoxy. For the thick laminate, the cutoff energy computed is 67.45 ft-lb, and the threshold energy is 6.75 ft-lb. The cutoff energy for the strength reduction is therefore 134.9 ft-lb. Figure 15 shows that the postimpact compression strength is significantly reduced for impact energy between 7 ft-lb and 70 ft-lb. For energy level below 7 ft-lb, there is no strength reduction, or the postimpact compression strength remains as the undamaged laminate strength. Beyond 70 ft-lb, the residual strength reduced at a much slower rate with energy. However, up to an energy level of 120 ft-lb the residual strength still decreases with increasing impact energy. For the thin laminate, the through penetration cutoff energy is 29.39 ft-lb and the strength cutoff is then 58.78 ft-lb. Figure 16 shows that the residual strength remains constant for impact energy above 60 ft-lb.

3.2.2 Full-Penetration Stress Concentration Parameter.

A full-penetration stress concentration parameter, C_2 , was defined in the stiffness reduction model. As shown in equation 6, simple empirical constant was used in the existing model. In

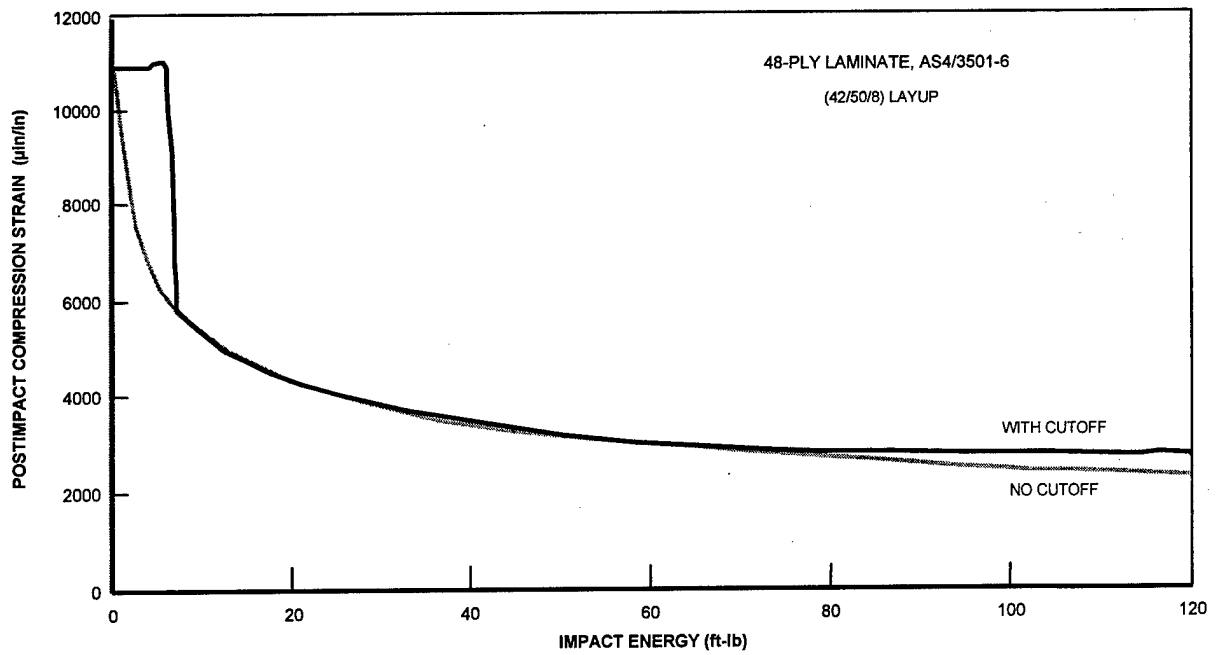

F98-HPK/15

FIGURE 15. EFFECTS OF CUTOFF AND THRESHOLD ENERGIES ON RESIDUAL STRENGTH—THICK LAMINATE

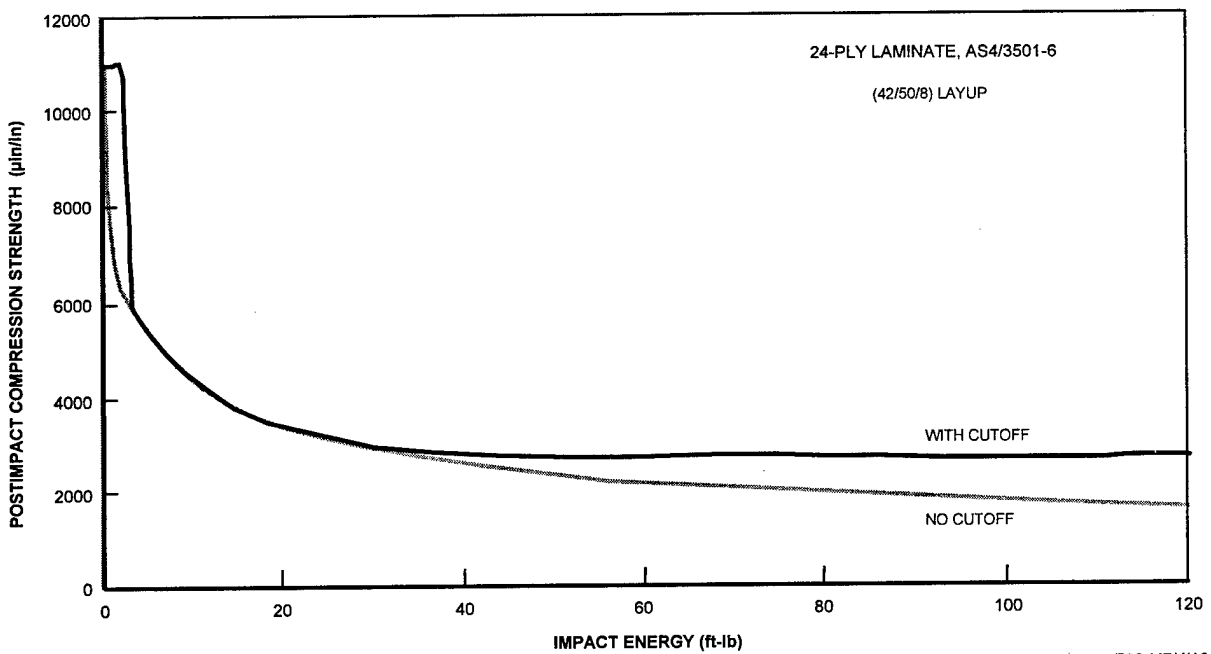

F98-HPK/16

FIGURE 16. EFFECTS OF CUTOFF AND THRESHOLD ENERGIES ON RESIDUAL STRENGTH—THIN LAMINATE

the modified model, this parameter is determined analytically. C_2 is computed as the stress concentration factor for an elliptical hole. The axes of the ellipse are D and $1.2D$ with the longer axis normal to the loading direction, where D is the impactor diameter. An aspect ratio of 1.2 is used for the ellipse to account for any irregular hole shape due to impact. The complex stress analysis method in reference 22 together with the average stress criteria in reference 21 are used in computing C_2 . With this modification, the interaction of impactor size and laminate layup is incorporated in the model. The effects of laminate layup on the value of C_2 is shown in table 10. The values shown in the table are based on the mechanical properties of typical AS4/3501-6 graphite/epoxy composites.

TABLE 10. EFFECTS OF LAMINATE LAYUP ON THE VALUE OF THE THROUGH PENETRATION PARAMETER C_2

Percent 0° Plies	20 Percent ±45° Plies	40 Percent ±45° Plies	60 Percent ±45° Plies	80 Percent ±45° Plies
0	2.7677	2.6841	2.6137	2.5069
10	3.1777	3.0081	2.8883	2.7373
20	3.5022	3.2766	3.1204	2.9172
30	3.7775	3.5124	3.3251	--
40	4.0215	3.7282	3.5075	--
50	4.2456	3.9335	--	--
60	4.4590	4.1372	--	--
70	4.6732	--	--	--
80	4.9098	--	--	--

3.2.3 Structural Configuration Effects.

The empirical stress (strain) distribution used in the original stiffness reduction model has been replaced by an analytical solution based on the elasticity method of reference 22. In the modified model, the gross failure strain of the structure is first computed based on the strain field determined from the elasticity solution and the average strain failure criterion. The approach in the modified model is similar to the original model. That is, a two-stage failure is assumed for the impact damaged structure. The impact damage is assumed to act as a slit after initial failure and the damage propagation is arrested by the stiffeners. After the initial failure, the damage is modeled as an elliptical hole with a length equal to the width of the damaged bay. The width of the slit is assumed equal to the impactor diameter. From the analytically determined structural failure strain, equation 12 is again used to compute the total failure load, and the procedure to determine the structure failure load is similar to that used in the original method.

3.2.4 Characterization of Data Scatter.

As discussed in section 2, very limited data available in the literature can be used for scatter characterization for the reliability analysis. The data used in references 1 and 2 were re-evaluated in the present program and the statistical parameters will be used in the reliability predictions.

The modifications of the stiffness reduction model were incorporated into the two computer codes, "PISTRE1" and "PISTRE2", developed in reference 2. These new codes are referred to as "PISTRE3" and "PISTRE4" and they are described in the appendix. PISTRE3, replacing PISTRE1, computes the initial (laminate) and final (structural) failure strain of a composite structure damage by low-velocity impact at a discrete impact energy level. PISTRE 4, replacing PISTRE2, computes the residual and reliability of a structure exposed to a given probabilistic impact threat. Typical results from these computer programs are shown in section 4.

4. ANALYTICAL RESULTS.

Results obtained from the modified reliability prediction for impact damaged structure codes are shown in this section. Comparisons of the present results with results obtained using PISTRE1 and PISTRE2 are presented in section 4.1. Results of a structural analysis, using the fighter aircraft structure from reference 2, are shown in section 4.2.

4.1 COMPARISON OF RESULTS.

The results of the examples showed in reference 2 are first compared with the results obtained from the modified model. A more detailed evaluation of the modified computer codes will be demonstrated later.

4.1.1 Example 1.

The sample problem used for PISTRE1 in reference 2 is used as the first example here. The input data for the example are:

- Laminate thickness: 0.2496 in., or 0.0052 in./ply
- Material properties: $E_L=18.7$ msi, $E_T=1.9$ msi, $G_{LT}=0.8$ msi, and $\nu_{LT}=0.3$
- Failure strain: 11000 microinches/in
- Fracture toughness: 0.75 in-lb/in²
- Impactor diameter: 1.0 in.
- Three spar panel with spar stiffness $(AE)=6.0 \times 10^6$ lb.
- Spar spacing: 7.0 in. (full bay width), adjacent partial bay width: 3.5 in., and remote partial bay width: 3.5 in.
- Single midbay impact with effective energy coefficient 1.0
- Impact energy: 80 ft-lb.
- Strain at DUL: 3000 microinches/in.

- For PISTRE3, the characteristic length for structural strength prediction is 1.0 in.
- Weibull scatter parameter is 12.0 and the sample size is 15.

The results are compared in table 11.

TABLE 11. COMPARISON OF RESULTS, PISTRE1 VERSUS PISTRE3

	PISTRE1	PISTRE3
Initial Failure Strain	2648	2823
Final Failure Strain	3436	3681
Requirement 1 B-Allowable, Margin of Safety	2880 -0.04	3086 0.03
Requirement 1 A-Allowable, Margin of Safety	2368 -0.21	2537 -0.15
Requirement 2 B-Allowable, Margin of Safety	3600 0.20	3857 0.29
	PISTRE1	PISTRE3
Requirement 2 A-Allowable, Margin of Safety	2960 -0.01	3171 0.06
Requirement 3 B-Allowable, Margin of Safety	3329 0.11	3550 0.18
Requirement 3 A-Allowable, Margin of Safety	2737 -0.09	2919 -0.03
Requirement 4 B-Allowable, Margin of Safety	2219 -0.26	2367 -0.21
Requirement 4 A-Allowable, Margin of Safety	1825 -0.39	1946 -0.35
Reliability at Design Ultimate Load		
Initial Failure	0.01987	0.16304
Structural Failure	0.84192	0.92758
Reliability at Maximum Spectrum Load		
Initial Failure	0.76393	0.88281
Structural Failure	0.98825	0.99485
Reliability at Design Limit Load		
Initial Failure	0.97025	0.98612
Structural Failure	0.99867	0.99942

The results in table 11 show that the modified model gives less conservative results. This is because of the cutoff energy effects. The penetration cutoff energy for this example is 67.45 ft-lb. The applied energy of 80 ft-lb is above the cutoff level and therefore higher residual strength is expected. The four damage tolerance requirements used in the above results were discussed in reference 2.

4.1.2 Example 2.

Results were also obtained for the example given in reference 2 for PISTRE2 using the modified code PISTRE4, and these results are compared in table 12. The medium impact threat, as described in section 3, is imposed on a 0.3586-in.-thick laminate with a (47/47/6) layup. The impacted bay is 4.5 in. wide and the design ultimate strain is 2700 microinches/in.

The results shown in table 12 indicate that the reliabilities computed based on the two models are similar, even though the minimum structural failure strain predicted by the modified model is higher.

TABLE 12. COMPARISON OF RESULTS, PISTRE2 VERSUS PISTRE4

	PISTRE2	PISTRE4
Minimum Structural Failure Strain	2787	3481
Requirement 1 B-Allowable, Margin of Safety	3063 0.13	3304 0.22
Requirement 1 A-Allowable, Margin of Safety	2438 -0.10	2755 0.02
Requirement 2 B-Allowable, Margin of Safety	3829 0.42	4130 0.53
Requirement 2 A-Allowable, Margin of Safety	3047 0.13	3444 0.28
Requirement 3 B-Allowable, Margin of Safety	3829 0.42	4130 0.53
Requirement 3 A-Allowable, Margin of Safety	3047 0.13	3444 0.28
Requirement 4 B-Allowable, Margin of Safety	3061 0.13	3007 0.11
Requirement 4 A-Allowable, Margin of Safety	2334 -0.14	2353 -0.13
Reliability at Design Ultimate Load		
Initial Failure	0.96139	0.95815
Structural Failure	0.96777	0.99254
Reliability at Maximum Spectrum Load		
Initial Failure	0.99560	0.99627
Structural Failure	0.99774	0.99957
Reliability at Design Limit Load		
Initial Failure	0.99947	0.99958
Structural Failure	0.99977	0.99995

4.2 STRUCTURAL EVALUATION.

The F/A-18A inner wing upper skin was evaluated for its impact damage tolerance capability in reference 2. This structure was re-evaluated here, using the modified stiffness reduction model. The wing skin material is AS4/3501-6 graphite/epoxy with thickness ranging from 0.36 to 0.78

in. The baseline skin layup is (48/48/4) and varies from (39/50/11) to (48/48/4). The substructure consists of the front, rear, and four intermediate spars. The skin compression strain at maximum design ultimate load (DUL) ranges from below 2500 microinches/in. to 3500 microinches/in. In the damage tolerance evaluation, the skin was subdivided into 45 regions based on the substructure arrangement and the skin thickness distribution. The subdivisions are summarized in table 13.

TABLE 13. SUBDIVISIONS OF THE F/A-18A INNER WING SKIN FOR DAMAGE TOLERANCE EVALUATION

Region	Layup	Thickness (in.)	Spar Spacing (in.)	Design Ultimate Load (lb.)
1	(47/47/6)	0.3586	4.500	2725
2	(47/47/6)	0.3586	6.500	2765
3	(48/48/4)	0.5250	5.375	2815
4	(45/52/3)	0.6498	9.000	2935
5	(46/48/6)	0.5250	5.125	2650
6	(47/47/6)	0.3586	5.375	2750
7	(47/47/6)	0.3586	6.725	2820
8	(48/48/4)	0.5250	5.650	2700
9	(45/52/3)	0.6498	9.300	2700
10	(44/48/8)	0.5250	5.575	3065
11	(46/50/4)	0.5042	6.125	2675
12	(45/50/5)	0.4210	7.000	3065
13	(44/52/4)	0.4834	5.875	3505
14	(44/50/6)	0.6706	9.750	3300
15	(39/50/11)	0.5874	6.000	2985
16	(46/50/4)	0.5042	6.250	2880
17	(48/48/4)	0.4418	6.425	3325
18	(46/50/4)	0.5042	6.075	2660
19	(44/50/6)	0.6706	10.200	3270
20	(42/48/10)	0.6082	6.550	2855
21	(46/50/4)	0.5042	6.750	2625
22	(48/48/4)	0.4418	7.000	3105
23	(46/50/4)	0.5042	6.200	3350
24	(44/50/6)	0.6706	10.800	3270
25	(42/48/10)	0.6082	7.375	3285
26	(45/48/7)	0.6082	7.500	2700
27	(45/48/7)	0.6082	7.000	2765
28	(45/48/7)	0.6082	6.200	3065

TABLE 13. SUBDIVISIONS OF THE F/A-18A INNER WING SKIN FOR DAMAGE TOLERANCE EVALUATION (Continued)

Region	Layup	Thickness (in.)	Spar Spacing (in.)	Design Ultimate Load (lb.)
29	(46/49/5)	0.7746	10.800	3100
30	(42/48/10)	0.6082	7.375	3480
31	(42/52/6)	0.6498	7.500	3090
32	(42/52/6)	0.6498	6.500	3440
33	(42/52/6)	0.6498	7.500	3390
34	(41/50/9)	0.6706	10.250	3440
35	(42/48/10)	0.6082	8.000	3000
36	(42/52/6)	0.6498	8.500	2855
37	(41/53/6)	0.6706	7.000	3205
38	(41/53/6)	0.6706	7.625	3195
39	(41/55/4)	0.6082	10.250	3090
40	(40/56/4)	0.5250	7.875	2610
41	(42/54/4)	0.5458	9.250	2855
42	(46/50/4)	0.5042	7.250	3205
43	(46/50/4)	0.5042	8.125	3195
44	(39/58/3)	0.6498	10.875	3090
45	(40/55/5)	0.6082	9.000	2500

The skin was evaluated for both the medium and high impact threats. The results of the evaluation are shown in table 14. The table shows the B-basis allowable, computed under the damage tolerance requirement that no catastrophic structural failure is allowed at DUL, the related margin of safety, and the structural reliability at DUL. In addition, the margin of safety based on the original model (reference 2) is also shown in the table for comparison purposes.

The results shown in table 14 indicate that Region 8 has the maximum margin of safety and Region 30 the minimum margin of safety. More detailed results for these regions are shown in figures 17 and 18. Figure 17 shows the structural reliability of Region 8 and figure 18 shows the structural reliability for Region 30. Both figures show the reliability under low, medium, and high impact threats. In addition, the effects of the value of the characteristic length, a_0 , on the damage tolerance capability for the two regions were studied in detail. The value of a_0 used in the study varied from 0.1 to 1.5 inches. It is found that these values of a_0 have no effect on the B-basis allowable, margin of safety, and the reliability for Region 30. But the results are significantly affected by a_0 for Region 8. The effects of a_0 for the two regions are shown in table 15.

TABLE 14. RESULTS OF THE STRUCTURAL DAMAGE TOLERANCE EVALUATION

Region	Medium-Threat B-Basis Allowable	Medium-Threat Margin of Safety	Margin of Safety (Ref. 2)	Medium-Threat Structural Reliability	High-Threat B-Basis Allowable	High-Threat Margin of Safety	High-Threat Structural Reliability
1	3336	0.22	0.13	0.99421	3215	0.18	0.99249
2	3691	0.34	0.25	0.99831	3603	0.30	0.99836
3	4085	0.45	0.31	0.99940	3974	0.41	0.99943
4	3911	0.33	0.32	0.99438	3315	0.13	0.97892
5	3488	0.32	0.34	0.99580	3120	0.18	0.98989
6	3156	0.15	0.15	0.98398	2972	0.08	0.96960
7	3659	0.30	0.16	0.99777	3565	0.26	0.99770
8	4020	0.49	0.40	0.99957	3904	0.45	0.99958
9	3913	0.45	0.47	0.99795	3299	0.22	0.99266
10	3555	0.16	0.15	0.97297	3058	0.00	0.89730
11	3491	0.31	0.35	0.99256	2946	0.10	0.97146
12	3682	0.20	0.11	0.99230	3537	0.15	0.98946
13	3985	0.14	0.09	0.98432	3849	0.10	0.97831
14	3954	0.20	0.18	0.97920	3296	0.00	0.89897
15	3867	0.30	0.15	0.99040	3187	0.07	0.94715
16	3494	0.21	0.44	0.98164	2933	0.02	0.91922
17	3780	0.14	0.02	0.98410	3664	0.10	0.97902
18	3932	0.48	0.34	0.99944	3796	0.43	0.99940
19	3955	0.21	0.19	0.98074	3276	0.00	0.90162
20	3811	0.34	0.36	0.99301	3130	0.10	0.95591
21	3503	0.33	0.28	0.99329	2888	0.10	0.96740
22	3734	0.20	0.05	0.99264	3614	0.16	0.99084
23	3914	0.17	0.12	0.98900	3770	0.13	0.98472
24	3955	0.21	0.17	0.98071	3269	0.00	0.89982
25	3819	0.16	0.14	0.97128	3138	-0.04	0.86468
26	3740	0.39	0.51	0.99529	3066	0.14	0.96528
27	3868	0.40	0.34	0.99862	3619	0.31	0.99781
28	3997	0.30	0.44	0.99700	3805	0.24	0.99582
29	4065	0.31	0.28	0.99201	3360	0.08	0.95101
30	3824	0.11	0.12	0.95236	3143	-0.10	0.81139
31	3949	0.28	0.31	0.98907	3255	0.05	0.93226
32	4050	0.18	0.22	0.98703	3764	0.09	0.97333
33	4001	0.18	0.20	0.98371	3593	0.06	0.95548
34	4043	0.18	0.14	0.97469	3349	-0.03	0.87781
35	3831	0.28	0.12	0.98884	3149	0.05	0.93046
36	3960	0.39	0.21	0.99550	3265	0.14	0.96635
37	4079	0.27	0.20	0.99421	3695	0.15	0.98672
38	4078	0.28	0.16	0.99315	3604	0.13	0.98114
39	3982	0.29	0.15	0.99053	3303	0.07	0.95133
40	3799	0.46	0.30	0.99735	3122	0.20	0.97995
41	3778	0.32	0.41	0.99217	3103	0.09	0.94762
42	3735	0.17	0.20	0.98711	3541	0.10	0.97845
43	3640	0.14	0.07	0.98128	3402	0.06	0.96121
44	4162	0.35	0.22	0.99414	3450	0.12	0.96256
45	3977	0.59	0.52	0.99910	3281	0.31	0.99220

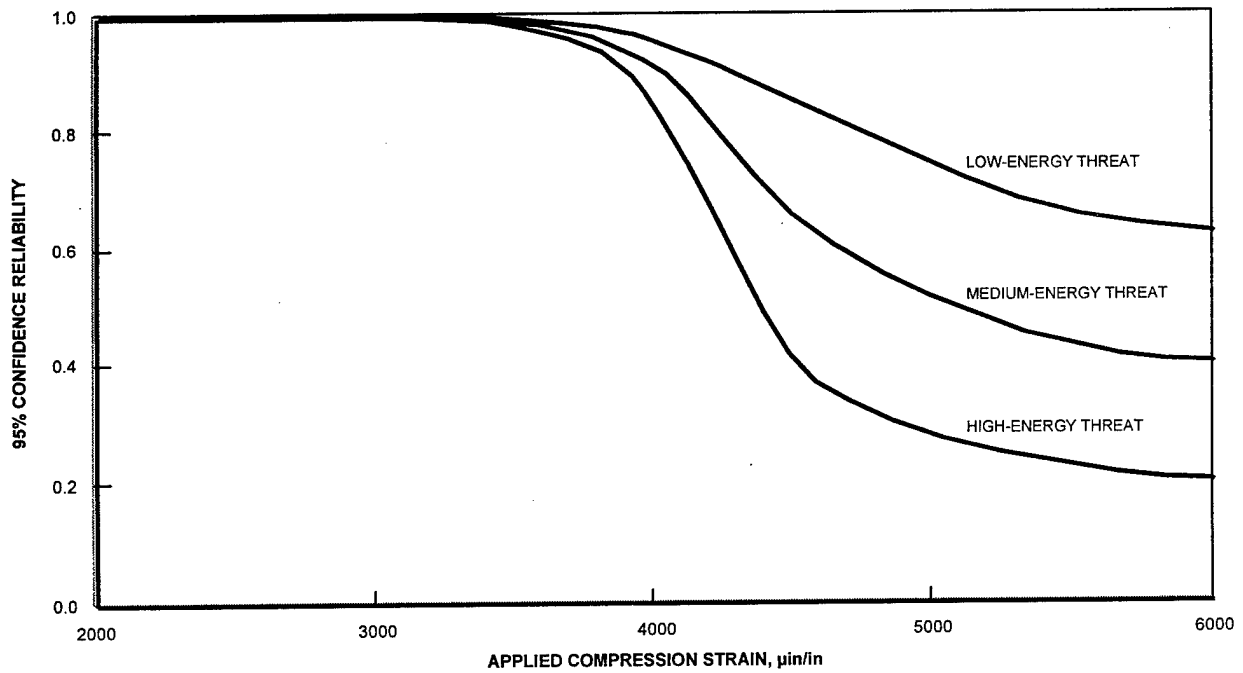

F98-HPK/17

FIGURE 17. STRUCTURAL RELIABILITY FOR REGION 8

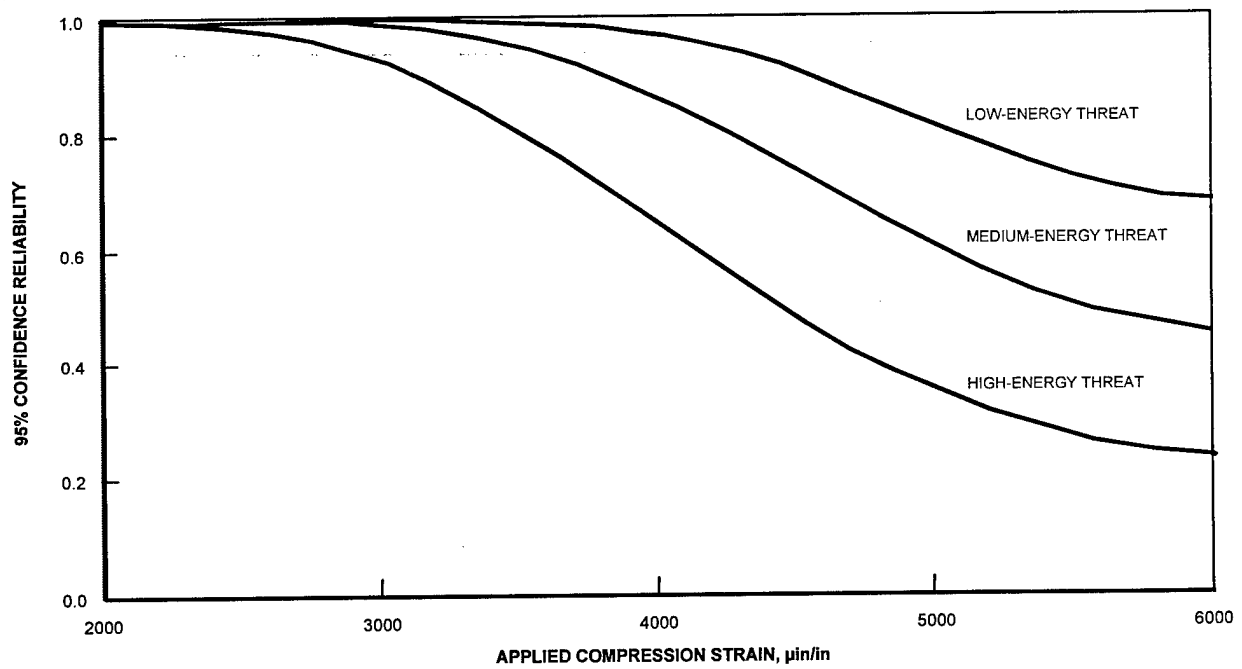

F98-HPK/18

FIGURE 18. STRUCTURAL RELIABILITY FOR REGION 30

TABLE 15. EFFECTS OF THE STRUCTURAL a_0 ON DAMAGE TOLERANCE

a_0	Margin of Safety	B-Basis Allowable (microinch/in.)	Structural Reliability
Region 8			
Low Threat			
0.10	0.57	4228	0.99899
0.25	0.57	4228	0.99899
0.50	0.57	4228	0.99904
0.75	0.57	4228	0.99936
1.00	0.59	4294	0.99970
1.25	0.67	4508	0.99988
1.50	0.76	4755	0.99995
Medium Threat			
0.10	0.31	3535	0.99094
0.25	0.31	3535	0.99094
0.50	0.31	3533	0.99492
0.75	0.37	3711	0.99845
1.00	0.49	4020	0.99957
1.25	0.60	4326	0.99986
1.50	0.71	4615	0.99995
High Threat			
0.10	0.07	2886	0.94090
0.25	0.07	2886	0.94090
0.50	0.15	3109	0.98620
0.75	0.30	3519	0.99784
1.00	0.45	3904	0.99958
1.25	0.57	4238	0.99989
1.50	0.68	4539	0.99996
Region 30			
Low Threat			
0.10-1.50	0.31	4554	0.99219
Medium Threat			
0.10-1.50	0.10	3824	0.95236
High Threat			
0.10-1.50	-0.10	3143	0.81139

4.3 EFFECTS OF SCATTER PARAMETERS.

The results of the data survey indicate that the experimental data is of limited use to statistically characterize the postimpact strength. This is true both in terms of the coupon data or the structural data. In order to assess the effects of the data scatter on the damage tolerance of the structure, a parametric study was conducted. The scatter parameter used in the study was selected based on the results of reference 2, which are summarized in table 16. The 48-ply

(42/50/8) graphite/epoxy laminate used in Example 1 is used for this study. The baseline Weibull scatter for postimpact strength scatter of laminate is $\alpha_L = 12$ and for structure is $\alpha_S = 20$. Table 16 shows the effects of these parameters on the B-basis damage tolerance design allowable. The effects of scatter on structural reliability are shown in figures 19 and 20. Figure 19 shows the effects of α_L as α_S is fixed. The effects of α_S on the structural reliability with α_L fixed are shown in figure 20.

TABLE 16. EFFECTS OF SCATTER PARAMETERS ON DAMAGE TOLERANCE DESIGN ALLOWABLES

$\alpha_S = 20, N_S = 15, N_L = 15$		$\alpha_L = 12, N_L = 15, N_S = 15$	
Variable α_L	B-Basis Allowable (microinch/in.)	Variable α_S	B-Basis Allowable (microinch/in.)
5	3134	10	3307
6	3244	11	3329
7	3312	12	3348
8	3355	13	3366
9	3389	14	3382
10	3413	15	3398
12	3444	16	3409
14	3467	17	3419
15	3477	18	3428
16	3485	19	3436
18	3499	20	3444
20	3507	22.5	3462
25	3521	25	3479
30	3530	30	3505

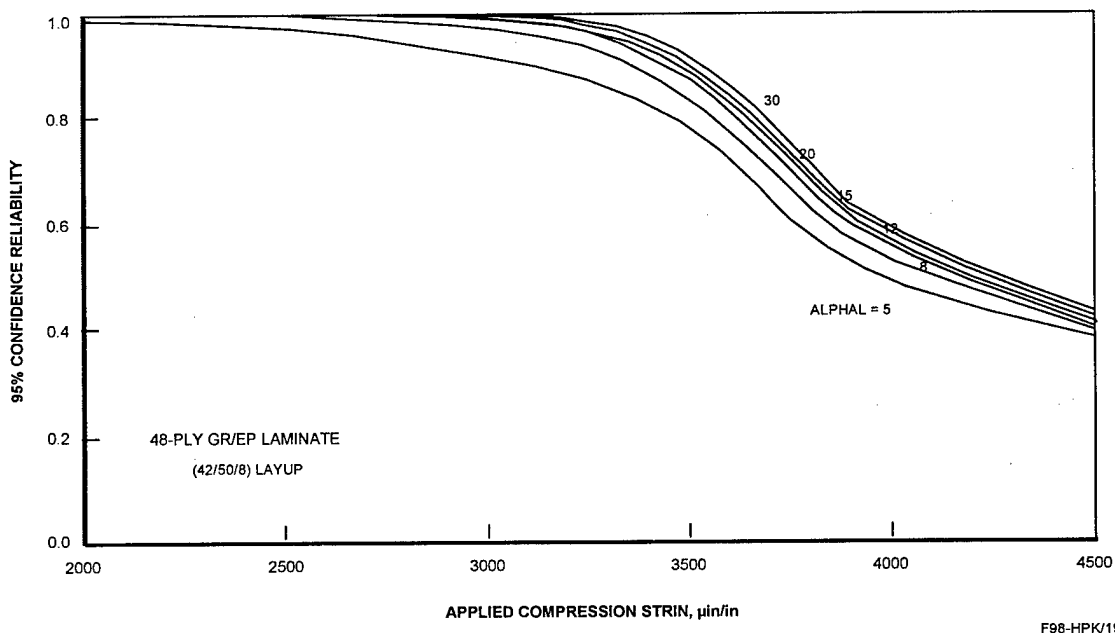

FIGURE 19. EFFECTS OF LAMINATE STRENGTH SCATTER ON RELIABILITY

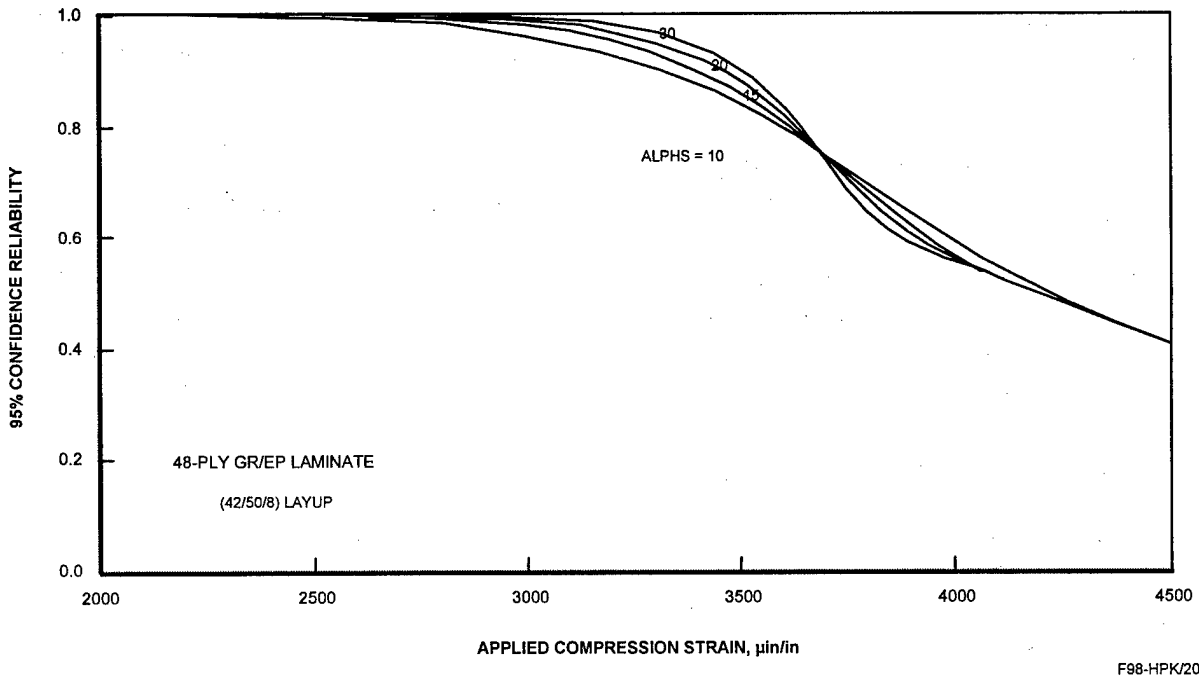

FIGURE 20. EFFECTS OF STRUCTURAL STRENGTH SCATTER ON RELIABILITY

5. CONCLUSIONS AND RECOMMENDATIONS.

5.1 SUMMARY.

The research program is summarized below.

- a. A technology assessment of the impact event on composite structures was conducted to identify the key parameters of damage resistance as well as damage tolerance.
- b. An existing damage tolerance evaluation model was modified to incorporate the results of the technology assessment and to reduce the empiricism of the model.
- c. A structural damage tolerance evaluation was conducted using the modified model and the results compared to those obtained from the existing model.

5.2 CONCLUSIONS.

The following conclusions may be drawn from the investigations undertaken in this program related to impact damage modeling.

- a. The experimental data generated during the last 10 years emphasized a particular material system or a special design feature. Therefore, limited data are suitable for general model development.

- b. Analytical model development during the last 10 years concentrated on the basic understanding of the impact responses of the composite. Limited engineering tools were developed.
- c. Design of the experiment test program identified important material, structural, and impact parameters and the effects of their interactions on the impact responses.
- d. The modified strength and reliability prediction model reduces the number of empirical constants and provides reasonable results as compared to those obtained using the existing model. The modified model is a convenient engineering tool for damage tolerance evaluation.
- e. The available data has limited use for statistical characterization of the postimpact scatter.

5.3 RECOMMENDATIONS.

The following are recommended to further develop the methodology and damage tolerance certification of composite structures.

- a. Develop general guidelines for damage tolerance evaluation of composite structures subjected to tension loading and combined mechanical and pressure loading.
- b. Investigate the validity of the current methodology on structures using new composite materials and new fabrication processes.

6. REFERENCES.

- 1. Horton, R. E., Whitehead, R. S., et al., "Damage Tolerance of Composites," Volumes I, II, and III, Report No. AFWAL-TR-87-3030, July 1988.
- 2. Kan, H. P., Cordero, R., and Whitehead, R. S., "Advanced Certification Methodology for Composite Structures," Final Report, NADC Contract No. N62269-87-C-0259, September 1989.
- 3. Abrate, Serge, "Impact on Laminated Composite Materials," Applied Mechanics Review, Vol. 44, No. 4, April 1991, American Society of Mechanical Engineers.
- 4. Cantwell, W. J. and Morton, J., "The Impact Resistance of Composite Materials - A Review," COMPOSITES, Vol. 22, No. 5, September 1991.
- 5. Wardle, Brian L., "Impact and Quasi-Static Response of Cylindrical Composite Shells," TELAC Report 95-4, Technology Laboratory for Advanced Composites, Department of Aeronautics and Astronautics, Massachusetts Institute of Technology, May 1995.
- 6. Demuts, E., Sandhu, R. S., and Daniels, J. A., "Post Impact Compressive Strength in Composites," Proceedings of the Ninth DOD/NASA/FAA Conference on Fibrous

- Composites in Structural Design, Report No. DOT/FAA/CT-92/25, II, September 1992, pp. 1097-1104.
7. Hinrichs, S., Chen, V., Jegley, D., Dickinson, L. C., and Kedward, K., "Effects of Impact on Stitched/RFI Compression Panels," Proceedings of the Fifth NASA/DOD Advanced Composites Technology Conference, NASA Conference Publication 3294, May 1995, Volume I, Part 2, pp. 879-912.
 8. Guy, T. A. and Lagace, P. A., "Compressive Residual Strength of Graphite/Epoxy Laminates After Impact," Proceedings of the Ninth DOD/NASA/FAA Conference on Fibrous Composites in Structural Design, Report No. DOT/FAA/CT-92/25, I, September 1992, pp. 253-274.
 9. Jegley, D., "Effect of Low-Speed Impact Damage and Damage Location on Behavior of Composite Panels," Proceedings of the Ninth DOD/NASA/FAA Conference on Fibrous Composites in Structural Design, Report No. DOT/FAA/CT-92/25, II, September 1992, pp. 1013-1036.
 10. Jackson, W. C. and Poe, C. C. Jr., "The Use of Impact Force as a Scale Parameter for the Impact Response of Composite Laminates," Proceedings of the Ninth DOD/NASA/FAA Conference on Fibrous Composites in Structural Design, Report No. DOT/FAA/CT-92/25, II, September 1992, pp. 981-998.
 11. Dost, E. F., Avery, W. B., Ilcewicz, L. B., Grande, D. H., and Coxon, B. R., "Impact Damage Resistance of Composite Fuselage Structure, Part I," Proceedings of the Ninth DOD/NASA/FAA Conference on Fibrous Composites in Structural Design, Report No. DOT/FAA/CT-92/25, II, September 1992, pp. 1037-1069.
 12. Dost, E. F., Finn, S. R., Murphy, D. P., and Huisken, A. B., "Impact Damage Resistance of Composite Fuselage Structure, Part 2," Proceedings of Third NASA Advanced Composites Technology Conference, NASA Conference Publication 3178, Part 2, Volume I, June 1992, pp. 759-787.
 13. Dost, E. F., Avery, W. B., Finn, S. R., Ilcewicz, L. B., and Scholz, D. B., "Impact Damage Resistance of Composite Fuselage Structure, Part 3," Proceedings of Fourth NASA Advanced Composites Technology Conference, NASA Conference Publication 3229, Part 1, Volume I, June 1993, pp. 205-241.
 14. Martin, R. H. and Hansen, P., "Effect of In-Service Loads on Impact Damage Using Biaxial Loading," Proceedings of the 37th AIAA/ASME/ASCE/AHS/ASC SDM Conference, Salt Lake City, UT, April 15-17, 1996, Part 1, pp. 339-347.
 15. Wardle, B. L. and Lagace, P. A., "Importance of Instability in the Impact Response of Composite Shells," Proceedings of the 37th AIAA/ASME/ASCE/AHS/ASC SDM Conference, Salt Lake City, UT, April 15-17, 1996, Part 3, pp. 1363-1373.

16. Ashton, H. R., "Damage Tolerance and Durability Testing for F/A-18E/F Composite Materials Structures," Proceedings, 37th AIAA/ASME/ASCE/AHS/ASC SDM Conference, Salt Lake City, UT, April 15-17, 1996, Part 1, pp. 1-13.
17. Shahid, I., Chang, F.-K., and Shah, B. M., "Impact Damage Resistance and Damage Tolerance of Composite with Progressive Damage," Proceedings, 37th AIAA/ASME/ASCE/AHS/ASC SDM Conference, Salt Lake City, UT, April 15-17, 1996, Part 2, pp. 766-775.
18. Goo, N. S. and Kim, S. J., "Dynamic Contact Analysis of Laminated Composite Plates Under Low-Velocity Impact," Proceedings, 37th AIAA/ASME/ASCE/AHS/ASC SDM Conference, Salt Lake City, UT, April 15-17, 1996, Part 2, pp. 776-786.
19. Lin, W., "The Point Force Response of Sandwich Panels and its Application to Impact Problems," Proceedings, 37th AIAA/ASME/ASCE/AHS/ASC SDM Conference, Salt Lake City, UT, April 15-17, 1996, Part 2, pp. 829-835.
20. Rose, R. A. and Starnes, J. H. Jr., "Approximate Analysis for Interlaminar Stresses in Composite Structure with Thickness Discontinuities," 37th AIAA/ASME/ASCE/AHS/ASC SDM Conference, Salt Lake City, UT, April 15-17, 1996, Part 3, pp. 1623-1638.
21. Whitney, J. M. and Nuismer, R. J., "Stress Fracture Criteria for Laminated Composites Containing Stress Concentrations," Journal of Composite Materials, Volume 8, 1974.
22. Lekhnitskii, S. G., Anisotropic Plates, 2nd edition, Translated from Russian by S. W. Tsai and T. Cheron, Gordon and Breach, 1968.

APPENDIX A—COMPUTER PROGRAMS

Two computer programs developed during the course of this research effort are documented in this appendix. These programs are written in FORTRAN language. The program listing and sample output are given below.

PISTRE3 Program Listing

```
IMPLICIT REAL*8(A-H,O-Z)
DIMENSION TITLE(18)
CHARACTER*3 ARE
COMMON /LAM/ A11,A12,A22,A16,A26,A66
WRITE(*,*) 'PLEASE ENTER PROBLEM TITLE'
CC INPUT A TITLE FOR THE PROBLEM
READ(*,1) TITLE
CC INPUT OF LAMINA PROPERTIES FOR STIFFNESS OF THE SKIN VIA LAMAD.
CALL LAMAD(A11,A12,A22,A16,A26,A66,ESK,T,AKT,EL)
WRITE(*,*) '
WRITE(*,*) ' IMPACT AND FAILURE PARAMETER INPUTS:'
WRITE(*,*) ' PLEASE ENTER SKIN FAILURE STRAIN IN MICROIN/IN'
CC INPUT OF FAILURE STRAIN FOR THE LAMINATE MATERILA, EULT
READ(*,*) EULT
WRITE(*,*) ' PLEASE ENTER TOUGHNESS--GIC'
CC INPUT OF FRACTURE TOUGHNESS, GIC
READ(*,*) GIC
WRITE(*,*) ' PLEASE ENTER IMPACT ENERGY'
CC INPUT OF IMPACT ENERGY LEVEL, E
READ(*,*) E
WRITE(*,*) ' PLEASE ENTER IMPACTOR DIAMETER '
CC INPUT OF IMPACTOR DIAMETER, D
READ(*,*) D
WRITE(*,*) ' PLEASE ENTER NUMBER OF SPARS AND SPAR AE IN 10**6'
CC INPUT NUMBER OF STIFFNER AND AE FOR STIFFNER
READ(*,*) NSP,AE
WRITE(*,*) ' PLEASE ENTER SPAR SPACING AND EDGE WIDTH A1,A2'
WRITE(*,*) ' AND THE CHARACTERISTIC LENGTH FOR FAILURE PREDICTION'
CC INPUT STIFFNER SPACING, B, WIDTH OF THE ADJACENT PARTIAL BAY, A1,
CC AND WIDTH OF THE REMOTE PARTIAL BAY, A2.
READ(*,*) B2,A1,A2,A0
WRITE(*,*) ' PLEASE ENTER EFFECTIVE ENERGY COEFFICIENT, AK'
CC INPUT AN EFFECTIVE ENERGY COEFFICIENT, AK.
READ(*,*) AK
WRITE(*,2)
CC INPUT IMPACT LOCATION CODE, ID.
READ(*,*) ID
WRITE(*,*) ' PLEASE ENTER STRAIN VALUE AT DESIGN ULTIMATE'
CC INPUT STRAIN LEVEL AT DESIGN ULTIMAT LAOD, DUL.
READ(*,*) DUL
CC INPUT WEIBULL SHAPE PARAMETER AND SAMPLE SIZE FOR
CC RELIABILITY COMPUTATION, DEFAULT ALP=12, NSAMPLE=15
WRITE(*,*) ' PLEASE ENTER STRENGTH ALPHA AND SAMPLE SIZE'
WRITE(*,*) ' DEFAULT ALPHA=12.0, N=15'
READ(*,*) ALP,NSAM
```

```

IF(ALP.EQ.0.0) ALP=12.0
IF(NSAM.EQ.0) NSAM=15
WRITE(*,*)'
WRITE(*,*)'
WRITE(*,*) ECHO OF IMPACT AND FAILURE PARAMETERS:'
WRITE(*,3) TITLE
WRITE(*,4) D,GIC
IF(ID.EQ.1.OR.ID.GT.3) WRITE(*,5)
IF(ID.EQ.2) WRITE(*,6)
IF(ID.EQ.3) WRITE(*,7)
WRITE(*,21) E
WRITE(*,22) AK
WRITE(*,23) NSP,AE
WRITE(*,24) B2,A1,A2
WRITE(*,25) EULT,DUL
WRITE(*,*)'
WRITE(*,*)' ECHO OF STRENGTH VARIABILITY PARAMETERS:'
WRITE(*,26) ALP,NSAM
PE = ESK/EL
AFP = 0.010
ACOF = 0.10
CC C1 IS THE LAMINATE LAYUP PARAMETER.
C1 = 0.54671*(PE**0.52647)
CC C2 IS THE FULL PENETRATION STRESS CONCENTRATION PARAMETER.
CC C2 IS COMPUTED FOR AN ELLIPTICAL HOLE WITH MAJOR AXIS EQUAL TO
CC 1.2 TIMES IMPACTOR DIAMETER AND MINOR AXIS EQUAL TO THE
CC IMPACTOR DIA. THE ASPECT RATIO FOR THE ELLIPSE IS TO ACCOUNT
CC FOR THE IRREGULAR SHAPE OF THE IMPACT PENETRATION.
RDA = D/2.0
RDB = 1.20*RDA
CC WRITE(*,*) 'AFP= ',AFP
CALL LEKHOLE(AFP,RDA,RDB,C2)
CC C2 = 3.707
CC C3 IS THE LAMINATE THICKNESS PARAMETER.
C3 = 0.499/(T**0.5056)
CC C4 IS THE MATERIAL TOUGHNESS PARAMETER.
CC C5 IS THE IMPACT ENERGY PARAMETER.
CC ENERGY AND TOUGHNESS INTERACTION IS ASSUMED.
C4 = 1.0
A4 = 0.07486/GIC+0.01448
GC = GIC
IF(GIC.GT.5.554) GC=5.554
B4 = (-0.00981*GC+0.10897)*GC+0.43449
C5 = A4*(AK*E)**B4
CC WE IS IMPACTOR SIZE PARAMETER
B = B2/2.0
WF = 2.*(A1+B)
WR = 1.0-D/WF
WE = (2.0+WR**3.0)/WR-1.0
CTOT = C1*C2*C3*C4*C5*WE
RESN = 1.0/(1.0+CTOT)
WRITE(*,*)'
WRITE(*,*)'
WRITE(*,*)' COEFFICIENTS FOR IMPACT PARAMETERS:'
WRITE(*,31) C1

```

```

WRITE(*,18) C2
WRITE(*,33) C3
WRITE(*,34) C4
WRITE(*,35) C5
WRITE(*,36) WE
CC COMPUTE THE CUTOFF STRENGTH BASED ON THE AVERAGE STRESS
CC CRITERION AND A TRAPEZOIDAL DAMAGE ZONE THROUGH THE THICKNESS
CC ASSUMPTION. AN ELLIPTICAL HOLE WITH AN ASPECT RATIO IS ALSO APPLIED.
  DDAM = D+6.0*T
  RDAMA = DDAM/2.0
  RDAMB = 1.50*RDAMA
CC  AEK = 0.05
  CALL LEKHOLE(ACOF,RDAMA,RDAMB,AVES)
CC  WRITE(*,16) ACOF,AVES
  AVF = 1.0/AVES
CC AVF IS THE CUTOFF STRENGTH REDUCTION.
CC ESTIMATE CUTOFF ENERGY AND THRESHOLD ENERGY
CC THE CUTOFF ENERGY IS BASED ON THE THROUGH PENETRATION CRITERION
CC THE RESIDUAL STRENGTH REMAINS CONSTANT WITH IMPACT ENERGY EXCEEDS
CC THE CUTOFF.
CC THE THRESHOLD ENERGY IS 0.1 OF THE CUTOFF OR 20 FT-LB WHICHEVER IS
CC LOWER.
  CTCUT = 1.0/AVF-1.0
  C5CUT = CTCUT/(C1*C2*C3*C4*WE)
  ECUT = C5CUT/A4
  ECUT = (ECUT)**(1.0/B4)
  ECUT = ECUT/AK
  ETHRE = ECUT/10.0
  IF (ETHRE.GT. 20.0) ETHRE = 20.0
CC FOR ENERGY LEVEL GREATER THAN ECUT, THE RESIDUAL STRENGTH
CC IS A FUNCTION OF DAMAGE SIZE ONLY.
CC FOR ENERGY LEVEL BETWEEN ECUT AND 2.0*ECUT THE EFFECTIVE DAMAGE SIZE
CC IS A FUNCTION OF GIC AND FOR ENERGY GREATER THAN 2.0*ECUT
CC THE DAMAGE SIZE IS CONSTANT.
  IF (E.GT.ECUT) THEN
    DMAT = 1.0/GIC
    DRES = DDAM+(E-ECUT)*DMAT/ECUT
    IF(E.GT.(2.0*ECUT)) DRES = DDAM+DMAT
    RRESA = DRES/2.0
    RRESB = 1.50*RRESA
CC  AA0 = 0.05
  CALL LEKHOLE(ACOF,RRESA,RRESB,AVES)
CC  WRITE(*,16) ACOF,AVES
  RESN = 1.0/AVES
  END IF
  IF (E.LT.ETHRE) RESN = 1.0
CC THE STRUCTURAL CONFIGURATION EFFECTS IN THE ORIGINAL MODEL WAS
CC EMPIRICALLY INCORPORATED. THE CURRENT VERSION USES LEKHNISKII
CC SOLUTION COMBINED WITH A AVERAGE STRAIN CRITERION.
CC THE FAILURE STRAIN IS COMPUTED USING THE AVERAGE STRAIN CRITERION.
CC THE CHARACTERISTIC LENGTH A0 IS AN INPUT PARAMETER AND THERE
CC IS NO EMPIRICAL CONSTANT FOR THE STRAIN DISTRIBUTION.
  SN = NSP
  B = B2/2.
  AB2 = A2+B2

```

```

W = A1+A2+2.0*B2
TE = T*ESK
SAE = TE*W+SN*AE
IF(ID.EQ.2.OR.ID.EQ.3) GOTO 250
AI = AMINI(A0,A1)
CALL LEKHOLE(AI,D,B,CONST)
CC  WRITE(*,16)AI,CONST
ELIM = EULT/CONST
CALL LEKHOLE(A1,D,B,CON1)
CC  WRITE(*,16)A1,CON1
CON1 = TE*A1*CON1
CALL LEKHOLE(AB2,D,B,CON2)
CC  WRITE(*,16) AB2,CON2
CON2 = TE*AB2*CON2
CON4 = SN*AE
FAC = CON1+CON2+CON4
PFL = ELIM*FAC
GOTO 100
CC  B1 = 6.54319
CC  ALPHA = 0.71257
CC  A0 = 1.31616
CC  IF(A1.LT.B) GOTO 151
CC  CON1 = TE*(A1-B+ALPHA*B*(1.+7.*B1/24.))
CC  GOTO 152
CC 151 CON1 = ALPHA*TE*(A1+B1*B*(1.-(B/(A1+B)))**3.)/3.)
CC 152 CON2 = TE*B*(1.+ALPHA*(1.+7.*B1/24.))
CC  CON3 = A2*TE
CC  CONST = 1.+B1*B*(1.-(B/(B+AI)))**3.)/(3.*AI)
250 CON4 = SN*AE
AI = AMINI(A0,A1,A2)
D2 = 2.0*D
CALL LEKHOLE(AI,D2,B2,CONST)
ELIM = EULT/CONST
CALL LEKHOLE(A1,D2,B2,CON1)
CON1 = TE*A1*CON1
CALL LEKHOLE(A2,D2,B2,CON2)
CON2 = TE*A2*CON2
FAC = CON1+CON2+CON4
PFL = ELIM*FAC
CC  IF(A1.LT.B2) GOTO 251
CC  CON1 = TE*(A1-B2+ALPHA*B2*(1.+7.*B1/24.))
CC  GOTO 252
CC 251 CON1 = ALPHA*TE*(A1+B1*B2*(1.-(B2/(A1+B2)))**3.)/3.)
CC 252 IF(A2.LT.B2) GOTO 253
CC  CON2 = TE*(A2-B2+ALPHA*B2*(1.+7.*B1/24.))
CC  GOTO 254
CC 253 CON2 = TE*ALPHA*(A2+B1*B2*(1.-(B2/(A2+B2)))**3.)/3.)
CC  CONST = 1.+B1*B2*(1.-(B2/(B2+AI)))**3.)/(3.*AI)
CC  PFL = ELIM*FAC
100 CONTINUE
RES = RESN*EULT
PIF = SAE*RES
ESP0 = PIF/FAC
ESPA = ESP0*CONST
ARE = 'YES'

```

```

IF(ESPA.GE.EULT) ARE='NO '
PFF = PIF
IF(ESPA.LT.EULT) PFF=PFL
EFF = PFF/SAE
WRITE(*,17) ECUT,ETHRE,RESN
WRITE(*,9) E,RES,EFF,DUL
CC  ALP = 12.0
ALI = 1.0/ALP
ALL = -ALOG(0.99)
ALL = ALL**ALI
BLL = -ALOG(0.90)
BLL = BLL**ALI
N2 = 2*NSAM
PL = 0.95
DPL = 0.01
CALL CHQ(N2,PL,DPL,CHI)
CHIQ = CHI/N2
ARG = 1.0+ALI
GM = GAMMA(ARG)
CC  WRITE(*,*) GM
FACTR = (CHIQ**ALI)*GM
FACTR = 1.0/FACTR
CC  WRITE(*,*) FACTOR
CC  FACTR = 1.01116
BIF = FACTR*RES
ALLIF = BIF*ALL
BLLIF = BIF*BLL
BFF = FACTR*EFF
ALLFF = BFF*ALL
BLLFF = BFF*BLL
ALLDIF = 1.50*ALLIF
ALLDFF = 1.25*ALLFF
ALLDUL = ALLDIF
BLLDIF = 1.50*BLLIF
BLLDFF = 1.25*BLLFF
BLLDUL = BLLDIF
IF(ALLDFF.LT.ALLDIF) ALLDUL = ALLDFF
IF(BLLDFF.LT.BLLDIF) BLLDUL = BLLDFF
AMS = ALLFF/DUL-1.0
BMS = BLLFF/DUL-1.0
WRITE(*,10)
WRITE(*,11) BLLFF,BMS,ALLFF,AMS
AMS = ALLDFF/DUL-1.0
BMS = BLLDFF/DUL-1.0
WRITE(*,12)
WRITE(*,11) BLLDFF,BMS,ALLDFF,AMS
AMS = ALLDUL/DUL-1.0
BMS = BLLDUL/DUL-1.0
WRITE(*,13)
WRITE(*,11) BLLDUL,BMS,ALLDUL,AMS
AMS = ALLIF/DUL-1.0
BMS = BLLIF/DUL-1.0
WRITE(*,14)
WRITE(*,11) BLLIF,BMS,ALLIF,AMS
PDULI = DUL/BIF

```

```

PDULI = -PDULI**ALP
PDULI = EXP(PDULI)
PDULF = DUL/BFF
PDULF = -PDULF**ALP
PDULF = EXP(PDULF)
PDLLI = DUL/(1.5*BIF)
PDLLI = -PDLLI**ALP
PDLLI = EXP(PDLLI)
PDLLF = DUL/(1.5*BFF)
PDLLF = -PDLLF**ALP
PDLLF = EXP(PDLLF)
PMSLI = DUL/(1.25*BIF)
PMSLI = -PMSLI**ALP
PMSLI = EXP(PMSLI)
PMSLF = DUL/(1.25*BFF)
PMSLF = -PMSLF**ALP
PMSLF = EXP(PMSLF)
WRITE(*,15) PDULI,PDULF,PMSLI,PMSLF,PDLLI,PDLLF
1 FORMAT(18A4)
2 FORMAT(3X,'PLEASE ENTER IMPACT EVENT CODE, ID',
& /8X,'ID = 1 SINGLE MID-BAY IMPACT',
& /8X,'ID = 2 TWO BAYS, MID-BAY IMPACTS',
& /8X,'ID = 3 SINGLE NEAR SPAR IMPACT')
3 FORMAT(/1X,18A4)
4 FORMAT(2X,'IMPACTOR DIAMETER          D =',F7.3
& /2X,'FRACTURE TOUGHNESS          GIC =',F7.3)
5 FORMAT(2X,'SINGLE MID-BAY IMPACT')
6 FORMAT(2X,'TWO BAYS MID-BAY IMPACTS')
7 FORMAT(2X,'SINGLE NEAR SPAR IMPACT')
9 FORMAT(2X,'ENERGY          E =',F7.2,
& /5X,'INITIAL FAILURE STRAIN =',F12.0,
& /5X,'FINAL FAILURE STRAIN = ',F12.0,
& /5X,'STRAIN AT DUL      = ',F12.0)
10 FORMAT(2X,'FOR DAMAGE TOLERANCE DESIGN REQUIREMENT NO. 1',
A /2X,'NO CATASTROPHIC STRUCTURAL FAILURE AT DUL')
11 FORMAT(5X,'B-BASIS ALLOWABLE STRAIN =',F12.0,2X,'M.S. =',F7.2
A /5X,'A-BASIS ALLOWABLE STRAIN =',F12.0,2X,'M.S. =',F7.2)
12 FORMAT(2X,'FOR DAMAGE TOLERANCE DESIGN REQUIREMANT NO. 2',
A /2X,'NO CATASTROPHIC STRUCTURAL FAILURE AT MSL=1.2DLL')
13 FORMAT(2X,'FOR DAMAGE TOLERANCE DESIGN REQUIREMANT NO. 3',
A /2X,'NO INITIAL FAILURE AT DLL AND NO CATASTROPHIC '
B /2X,'STRUCTURAL FAILURE AT MSL')
14 FORMAT(2X,'FOR DAMAGE TOLERANCE DESIGN REQUIREMANT NO. 4',
A /2X,'NO INITIAL/LOCAL FAILURE AT DLL')
15 FORMAT(2X,'RELIABILITY AT DUL: IF =',F12.5,2X,'FF =',F12.5,
+ /2X,'RELIABILITY AT MSL: IF =',F12.5,2X,'FF =',F12.5,
+ /2X,'RELIABILITY AT DLL: IF =',F12.5,2X,'FF =',F12.5)
16 FORMAT(2X,'FOR THE CHARACTERISTIC LENGTH ACOF =',F7.4,
& /2X,'THE AVERAGE STRESS FACTOR IS',F9.4)
17 FORMAT(2X,'ENERGY CUTOFF =',F12.2,
& /2X,'ENERGY-THRESHOLD =',F12.2,
& /2X,'RESIDUAL STRENGTH RATIO =',F9.4)
31 FORMAT(2X,'LAMINATE LAYUP PARAMETER C1 =',F12.5)
18 FORMAT(2X,'FULL PENETRATION PARAMETER C2 =',F9.4)
33 FORMAT(2X,'LAMINATE THICKNESS PARAMETER C3 =',F12.5)

```

```

34 FORMAT(2X,'MATERIAL TOUGHNESS PARAMETER C4 =',F12.5)
35 FORMAT(2X,'IMPACT ENERGY PARAMETER C5 =',F12.5)
36 FORMAT(2X,'PANEL WIDTH PARAMETER WE =',F12.5)
21 FORMAT(2X,'IMPACT ENERGY IN FT-LB, E =',F7.2)
22 FORMAT(2X,'EFFECTIVE ENERGY COEFFICIENT, AK =',F9.4)
23 FORMAT(2X,'TOTAL NUMBER OF STIFFENERS IN PANEL, NSP =',I3,
& /2X,'STIFFNESS OF EACH STIFFENER, AE =',E12.6)
24 FORMAT(2X,'WIDTH OF IMPACTED AND ADJACENT FULL BAY =',F7.2,
& /2X,'WIDTH OF THE ADJACENT PARTIAL BAY A1 =',F7.2,
& /2X,'WIDTH OF THE REMOTE PARTIAL BAY A2 =',F7.2)
25 FORMAT(2X,'FAILURE STRAIN FOR THE UNDAMAGED, UNNOTCHED'
& /2X,'SKIN LAMINATE EULT =',F12.0,
& /2X,'STRAIN FOR DESIGN ULTIMATE, DUL =',F12.0)
26 FORMAT(/2X,'FOR RELIABILITY COMPUTATION',
& /2X,'THE WEIBULL ALPHA =',F7.2,
& /2X,'FOR A SAMPLE SIZE OF',I5)
110 STOP
END
SUBROUTINE LEKHOLE(A0,A,B,AVFS)
IMPLICIT REAL*8(A-H,O-Z)
COMPLEX*16 EU1,EU2,Z1,Z2,Z12,Z22
COMPLEX*16 SI1,SI2,SI1R,SI2R,EU12,EU22
COMPLEX*16 F1,F2,F1I,F2I
COMPLEX*16 EYE,BET,FORCE1,FORCE2,PH1P,PH2P
COMPLEX*16 G,GP,RT,RT2,C0,C1,C2,C3,C4,CP1,CP2,CP3,C,AC,BC,AMU
DIMENSION AA(3,3),AVES(501)
COMMON /LAM/ A11,A12,A22,A16,A26,A66
CC THE APPLIED FORCE IS A UNIT STRESS IN THE X-DIRECTION
CC OR P = 1.0, Q = 0.0, T = 0.0
EYE = (0.0, 1.0)
PI = 4.0*ATAN(1.0)
PI2 = PI/2.0
NK = 50
IF(A0.EQ.0.0) GOTO 50
FNK = DFLOAT(NK)
DYB = A0/FNK
IF(DYB.GT.0.01) DYB = 0.01
FNK = A0/DYB+0.2
NK = FNK
IF(NK.GT.500) NK = 500
DYB = A0/NK
NK1 = NK+1
50 A2 = A*A
B2 = B*B
ESP = 0.000001
AA(1,1) = A11
AA(1,2) = A12
AA(2,1) = A12
AA(1,3) = A16
AA(3,1) = A16
AA(2,2) = A22
AA(2,3) = A26
AA(3,2) = A26
AA(3,3) = A66
CALL MINV(3,AA)

```



```

IF((AA(1,3).EQ.0.0).AND.(AA(2,3).EQ.0.0)) GOTO 140
C4 = AA(1,1)
C3 = -2.0*AA(1,3)
C2 = 2.0*AA(1,2)+AA(3,3)
C1 = -2.0*AA(2,3)
C0 = AA(2,2)
RT = (0.0, 0.0)
DO 120 I=1,300
G = C4*RT**4.0+C3*RT**3.0+C2*RT*RT+C1*RT+C0
GP = 4.0*C4*RT**3.0+3.0*C3*RT*RT+2.0*C2*RT+C1
IF(CDABS(G) .LT.1.0E-10) GOTO 130
IF(CDABS(GP).EQ.0.0) GOTO 121
GOTO 122
121 WRITE(*,*) 'THE LAMINATE HAS A SINGULAR CHARAC. EQUATION!'
STOP
122 RT = RT-G/GP
120 CONTINUE
130 SP1 = -(RT+DCONJG(RT))
SP0 = RT*DCONJG(RT)
CP1 = C4
CP2 = C3-SP1*C4
CP3 = (C2-C4*SP0)-SP1*CP2
RT2 = (-CP2+(CP2*CP2-4.0*CP1*CP3)**0.5)/(2.0*CP1)
EU1 = DCMLPX(DREAL(RT),DABS(DIMAG(RT)))
EU2 = DCMLPX(DREAL(RT2),DABS(DIMAG(RT2)))
GOTO 150
140 BC = 2.0*AA(1,2)+AA(3,3)
AC = AA(1,1)
C = AA(2,2)
AMU = BC*BC-4.0*AC*C
ZX = DREAL(AMU)
ZY = DIMAG(AMU)
THO = ATAN(ZY/ZX)
CALL ROOT(THO,ZX,ZY,AMUR,AMUI)
EU1 = -BC+DCMLPX(AMUR,AMUI)
EU1 = EU1/(2.0*AA(1,1))
ZX = DREAL(EU1)
ZY = DIMAG(EU1)
THO = ATAN(ZY/ZX)
CALL ROOT(THO,ZX,ZY,XX,YY)
EU1 = DCMLPX(XX,YY)
EU2 = -BC-DCMLPX(AMUR,AMUI)
EU2 = EU2/(2.0*AA(1,1))
ZX = DREAL(EU2)
ZY = DIMAG(EU2)
THO = ATAN(ZY/ZX)
CALL ROOT(THO,ZX,ZY,XX,YY)
EU2 = DCMLPX(XX,YY)
IF(CDABS(EU1-DCONJG(EU2)).LT.1.0E-5) EU2 = -DCONJG(EU1)
150 CONTINUE
EU12 = EU1*EU1
EU22 = EU2*EU2
BET = -EYE*B/2.0
FORCE1 = -BET*(A-EYE*B*EU1)/(EU1-EU2)
FORCE2 = BET*(A-EYE*B*EU2)/(EU1-EU2)

```

```

RB = B
TH = PI2
KK = 1
110 CONTINUE
RA = RB*A/B
CC TO CHOOSE THE CORRECT BRANCH IN THE SQUARE ROOTS FOR STRESS
CC SOLUTION, SUBROUTINE 'ROOT1' IS USED AND THE LOWER AND UPPER
CC BOUND OF THE CORRECT CHOICE IS INITIALIZED HERE.
X = RA
Y = 0.0
Z1 = X
Z2 = X
Z12 = Z1*Z1
Z22 = Z2*Z2
SI1 = Z12-A2-B2*EU12
SI2 = Z22-A2-B2*EU22
SX = REAL( SI1)
SY = AIMAG(SI1)
IF(ABS(SX).LT.ESP) SX=0.0
IF(ABS(SY).LT.ESP) SY=0.0
IF(SX.EQ.0.0.AND.SY.GT.0.0) GOTO 701
IF(SX.EQ.0.0.AND.SY.LT.0.0) GOTO 702
THI0 = DATAN(SY/SX)
IF(SX.LT.0.0.AND.SY.GT.0.0) THI0 = PI+THI0
IF(SX.LT.0.0.AND.SY.LT.0.0) THI0 = THI0-PI
GOTO 703
701 THI0 = PI2
GOTO 703
702 THI0 = -PI2
703 CONTINUE
TH112 = THI0/2.0
TH11P = TH112+PI
CC TH112D = 180.0*TH112/PI
CC TH11PD = 180.0*TH11P/PI
CC WRITE(*,70) TH112D,TH11PD
CC 70 FORMAT(2X,'LOWER LIMIT FOR ROOT OF SI1 (deg) =',F6.2,
CC & /2X,'UPPER LIMIT FOR ROOT OF SI1 (deg) =',F6.2)
CC 71 FORMAT(2X,'LOWER LIMIT FOR ROOT OF SI2 (deg) =',F6.2,
CC & /2X,'UPPER LIMIT FOR ROOT OF SI2 (deg) =',F6.2)
SX = REAL( SI2)
SY = AIMAG(SI2)
IF(ABS(SX).LT.ESP) SX=0.0
IF(ABS(SY).LT.ESP) SY=0.0
IF(SX.EQ.0.0.AND.SY.GT.0.0) GOTO 704
IF(SX.EQ.0.0.AND.SY.LT.0.0) GOTO 705
THI1 = DATAN(SY/SX)
IF(SX.LT.0.0.AND.SY.GT.0.0) THI1 = PI+THI1
IF(SX.LT.0.0.AND.SY.LT.0.0) THI1 = THI1-PI
GOTO 706
704 THI1 = PI2
GOTO 706
705 THI1 = -PI2
706 CONTINUE
TH222 = THI1/2.0
TH22P = TH222+PI

```

```

CC TH222D = 180.0*TH222/PI
CC TH22PD = 180.0*TH22P/PI
CC WRITE(*,71) TH222D,TH22PD
  X = 0.0
  Y = RB
  Z1 = EU1*Y
  Z12 = Z1*Z1
  Z2 = EU2*Y
  Z22 = Z2*Z2
  SI1 = Z12-A2-B2*EU12
  SI2 = Z22-A2-B2*EU22
  SX = REAL(SI1)
  SY = AIMAG(SI1)
  IF(ABS(SX).LT.ESP) SX=0.0
  IF(ABS(SY).LT.ESP) SY=0.0
  TH102 = TH112
  TH10P = TH11P
  CALL ROOT1(TH,SX,SY,TH102,TH10P,XX,YY)
CC
CC TH0 = DATAN(SY/SX)
CC IF(SX.LT.0.0.AND.SY.GE.0.0) TH0 = PI+TH0
CC IF(SX.LT.0.0.AND.SY.LT.0.0) TH0 = TH0+PI
CC IF(SX.GT.0.0.AND.SY.LT.0.0) TH0 = TH0+2.0*PI
CC CALL ROOT(TH0,SX,SY,XX,YY)
  SI1R = CMPLX(XX,YY)
  SX = REAL(SI2)
  SY = AIMAG(SI2)
  IF(ABS(SX).LT.ESP) SX=0.0
  IF(ABS(SY).LT.ESP) SY=0.0
  TH112 = TH222
  TH11P = TH22P
  CALL ROOT1(TH,SX,SY,TH112,TH11P,XX,YY)
CC TH1 = DATAN(SY/SX)
CC IF(SX.LT.0.0.AND.SY.GE.0.0) TH1 = PI+TH1
CC IF(SX.LT.0.0.AND.SY.LT.0.0) TH1 = TH1+PI
CC IF(SX.GT.0.0.AND.SY.LT.0.0) TH1 = TH1+2.0*PI
CC CALL ROOT(TH1,SX,SY,XX,YY)
  SI2R = CMPLX(XX,YY)
  F1I = (Z1+SI1R)*SI1R
  F2I = (Z2+SI2R)*SI2R
  F1 = 1.0/F1I
  F2 = 1.0/F2I
  PH1P = FORCE1*F1
  PH2P = FORCE2*F2
  SIGX = 1.0+2.0*REAL(EU12*PH1P+EU22*PH2P)
CC WRITE(*,1) RA, RB, SIGX
CC SIGY = 2.0*REAL( PH1P+ PH2P)
CC SIGXY = -2.0*REAL( EU1*PH1P+ EU2*PH2P)
CC IF A0=0.0 THEN SIGX AT THE HOLE BOUNDARY IS THE ACTUAL Kt
CC THIS IS THE Kt TO BE USED IN COMPUTING THE STRESS CONCENTRATION
CC FACTOR C2, IN THE MODEL.
  IF(A0.EQ.0.0) THEN
    SUMS = SIGX
    GOTO 107
  ENDIF

```

```

AVES(KK) = SIGX
IF(KK.GE.NK1) GOTO 105
RB = RB+DYB
KK = KK+1
GOTO 110
105 CONTINUE
SUMS = AVES(1)
DO 106 I=2,NK
106 SUMS = SUMS+2.0*AVES(I)
SUMS = SUMS+AVES(NK1)
SUMS = SUMS/(2.0*NK)
107 AVFS = SUMS
1 FORMAT(2X,'RA = ',F7.3,2X,'RB = ',F7.3,2X,'SIGX = ',F9.4)
CC HOLFAC = SUMS/P
999 RETURN
END
SUBROUTINE ROOT(TH0,X,Y,XX,YY)
IMPLICIT REAL*8(A-H,O-Z)
PI = 4.0*ATAN(1.0)
PI4 = PI/4.0
ANI = 0.5
R = X*X+Y*Y
R = SQRT(R)
RN = R**ANI
IF(X.EQ.0.0.AND.Y.GT.0.0) GOTO 10
IF(X.EQ.0.0.AND.Y.LT.0.0) GOTO 15
TH = ATAN(Y/X)
IF(X.LT.0.0.AND.Y.GE.0.0) TH = PI+TH
IF(X.LT.0.0.AND.Y.LT.0.0) TH = TH+PI
IF(X.GT.0.0.AND.Y.LT.0.0) TH = TH+2.0*PI
GOTO 20
10 TH = PI/2.0
GOTO 20
15 TH = 3.0*PI/2.0
20 THN = TH/2.0
XX = RN*COS(THN)
YY = RN*SIN(THN)
CC THD = ABS(TH-TH0)
CC IF(THD.GE.PI4) THEN
CC XX = -XX
CC YY = -YY
CC TH = TH+PI
CC ENDIF
TH0 = TH
RETURN
END
SUBROUTINE ROOT1(TXY,X,Y,TH2,THP,XX,YY)
IMPLICIT REAL*8(A-H,O-Z)
PI = 4.0*ATAN(1.0)
PI4 = PI/4.0
PI2 = 2.0*PI
PI22 = PI/2.0
ANI = 0.5
R = X*X+Y*Y
R = SQRT(R)

```

```

RN = R**ANI
IF(TXY.EQ.0.0) THEN
  THN = TH2
  GOTO 30
ENDIF
IF(TXY.GT.PI) THEN
  TH2 = TH2+PI
  THP = THP+PI
ENDIF
IF(X.EQ.0.0.AND.Y.GT.0.0) GOTO 10
IF(X.EQ.0.0.AND.Y.LT.0.0) GOTO 15
TH = ATAN(Y/X)
IF(X.LT.0.0.AND.Y.GE.0.0) TH = PI+TH
IF(X.LT.0.0.AND.Y.LT.0.0) TH = TH-PI
GOTO 20
10 TH = PI22
  GOTO 20
15 TH = -PI22
20 CONTINUE
  IF(TXY.GT.PI) TH = TH+PI2
  THN1 = TH/2.0
  THN2 = THN1+PI
CC  THN1D = 180.0*THN1/PI
CC  THN2D = 180.0*THN2/PI
CC  WRITE(*,1) THN1D,THN2D
  THN = THN1
  IF(THN.LT.TH2.OR.THN.GT.THP) THN = THN2
CC  THND = 180.0*THN/PI
CC  WRITE(*,2) THND
CC  1 FORMAT(2X,'THE TWO HALF ANGLES ARE:',2F9.2)
CC  2 FORMAT(2X,'THE CORRECT BRANCH IS :',2F9.2)
30 XX = RN*COS(THN)
  YY = RN*SIN(THN)
  RETURN
  END
SUBROUTINE MINV(N,A)
  IMPLICIT REAL*8(A-H,O-Z)
  DIMENSION A(3,3)
  DO 1 I=1,N
    X = A(I,I)
    A(I,I) = 1.0
  DO 2 J=1,N
    2 A(I,J) = A(I,J)/X
    DO 1 K=1,N
      IF(K-I) 3,1,3
    3 X = A(K,I)
      A(K,I) = 0.0
    DO 4 J=1,N
    4 A(K,J) = A(K,J) -X*A(I,J)
  1 CONTINUE
  RETURN
  END
SUBROUTINE LAMAD(Q11B,Q12B,Q22B,Q16B,Q26B,Q66B,EX,TT,AKT,EL1)
  IMPLICIT REAL*8(A-H,O-Z)
  DIMENSION TH(100),MTY(100),EL(10),ET(10),GLT(10),PNU(10),T(10)

```

```

COMMON /LAM/ A11,A12,A22,A16,A26,A66
PI = 4.0D0*DATAN(1.0D0)
PI2 = PI*PI
WRITE(*,*) '
WRITE(*,*) ' LAMINATE DATA INPUTS:'
WRITE(*,1)
READ(*,*) N,KSY,M
WRITE(*,*) ' PLEASE ENTER PLY-ORIENTATION IN DEGREE FOR EACH PLY:'
READ(*,*) (TH(I), I=1,N)
WRITE(*,*) ' PLEASE ENTER MATERIAL CODE FOR EACH PLY'
READ(*,*) (MTY(I),I=1,N)
IF(KSY.NE.0) GOTO 50
DO 51 I=1,N
MTY(N+I) = MTY(N-I+1)
51 TH(N+I) = TH(N-I+1)
N = 2*N
50 CONTINUE
DO 70 I=1,M
WRITE(*,2) I
70 READ(*,*) EL(I),ET(I),GLT(I),PNU(I),T(I)
WRITE(*,*) '
WRITE(*,*) '
WRITE(*,*) ' LAMINATE PROPERTY SUMMARY:'
WRITE(*,3) N
IF(KSY.EQ.0) WRITE(*,11)
IF(KSY.NE.0) WRITE(*,12)
WRITE(*,13) M
WRITE(*,*) '
WRITE(*,*) ' PLY ORIENTATION, THETA (DEGREES)'
WRITE(*,4) (TH(J), J=1,N)
WRITE(*,*) '
WRITE(*,*) ' MATERIAL CODES'
WRITE(*,5) (MTY(J),J=1,N)
WRITE(*,6)
DO 75 I=1,M
75 WRITE(*,7) I,EL(I),ET(I),GLT(I),PNU(I),T(I)
EL1 = EL(I)
TT = 0.0D0
DO 52 I=1,N
TT = TT+T(MTY(I))
52 TH(I) = TH(I)*PI/1.800D+2
Q11B = 0.0D0
Q12B = 0.0D0
Q22B = 0.0D0
Q66B = 0.0D0
Q16B = 0.0D0
Q26B = 0.0D0
DO 60 I=1,N
TI = T(MTY(I))
P2 = PNU(MTY(I))*PNU(MTY(I))
QT = EL(MTY(I))/(EL(MTY(I))-P2*ET(MTY(I)))
Q11 = EL(MTY(I))*QT
Q22 = ET(MTY(I))*QT
Q12 = PNU(MTY(I))*Q22
Q66 = GLT(MTY(I))

```

```

QT1 = Q11+Q22
QT2 = 4.0D0*Q66
QT3 = 2.0D0*Q12
U1 = (3.0D0*QT1+QT3+QT2)/8.0D0
U2 = (Q11-Q22)/2.0D0
U3 = (QT1-QT3-QT2)/8.0D0
U4 = (QT1+3.0D0*QT3-QT2)/8.0D0
U5 = (QT1-QT3+QT2)/8.0D0
U61 = (Q11-Q12-2.0D0*Q66)/8.0D0
U62 = (Q12-Q22+2.0D0*Q66)/8.0D0
TH2 = 2.0D0*TH(I)
TH4 = 4.0D0*TH(I)
CO2 = DCOS(TH2)
CO4 = DCOS(TH4)
CS = 2.0D0*DSIN(TH2)+DSIN(TH4)
SC = 2.0D0*DSIN(TH2)-DSIN(TH4)
Q1 = U1+U2*CO2+U3*CO4
Q2 = U1-U2*CO2+U3*CO4
Q3 = U4-U3*CO4
Q6 = U5-U3*CO4
Q16 = U61*CS+U62*SC
Q26 = U61*SC+U62*CS
Q11B = Q11B+Q1*TI
Q22B = Q22B+Q2*TI
Q12B = Q12B+Q3*TI
Q66B = Q66B+Q6*TI
Q16B = Q16B+Q16*TI
Q26B = Q26B+Q26*TI
60 CONTINUE
A11 = Q11B
A12 = Q12B
A22 = Q22B
A16 = Q16B
A26 = Q26B
A66 = Q66B
QB = (A11*A22-A12*A12)/TT
EX = QB/A22
EY = QB/A11
GXY = A66/TT
UXY = A12/A22
UYX = A12/A11
AKT = 2.0*(EX/EY-UXY)
AKT = AKT+EX/EY
AKT = 1.0+DSQRT(AKT)
CC AKT IS THE THEORETICAL STRESS CONCENTRATION FACTOR.
WRITE(*,8) A11,A12,A22,A16,A26,A66
WRITE(*,9) EX,EY,GXY,UXY,AKT,TT
1 FORMAT(3X,'PLEASE ENTER N,KSY AND M',
& /8X,'N IS THE NUMBER OF PLYS IN THE LAMINATE'
& /8X,'OR HALF OF TOTAL NO. OF PLYS IF SYMMETRIC',
& /8X,'KSY IS THE LAMINATE TYPE CODE',
& /8X,'KSY=0 FOR SYMMETRIC LAMINATE',
& /8X,'M IS THE NUMBER OF MATERIALS IN THE LAMINATE')
2 FORMAT(3X,'PLEASE ENTER LAMINA PROPERTIES FOR MATERIAL TYPE',I3,
& /8X,'EL,ET,GLT,NULT,T')

```

```

3 FORMAT(9X,I2,'-PLY LAMINATE')
11 FORMAT(9X,'LAMINATE TYPE: SYMMETRY')
12 FORMAT(9X,'LAMINATE TYPE: NON-SYMMETRY')
13 FORMAT(9X,'NO. OF MATERIALS M = ',I3)
4 FORMAT(4X,12F5.0)
5 FORMAT(3X,12I5)
6 FORMAT(3X,'TYPE',2X,'EL',10X,'ET',10X,'GLT',9X,'NULT',8X,'T')
7 FORMAT(4X,I3,4E12.5,F7.4)
8 FORMAT(3X,'SKIN A-MATRIX:',
& /5X,'A11 = ',E12.6,2X,'A12 = ',E12.6,2X,'A22 = ',E12.6,
& /5X,'A16 = ',E12.6,2X,'A26 = ',E12.6,2X,'A66 = ',E12.6)
9 FORMAT(3X,'SKIN MODULUS:',
& /5X,'EX = ',E12.6,2X,'EY = ',E12.6,2X,'GXY = ',E12.6,
& /5X,'MAJOR POISSON RATIO          VXY = ',F9.4,
& /5X,'THEORETICAL MAJOR Kt FOR CIRCULAR HOLE = ',F9.4
& /5X,'SKIN THICKNESS              T = ',F9.4/)
RETURN
END
CC USE OF CHISQ AS A SUBROUTINE
CCCC CHI-SQUARE DISTRIBUTION
SUBROUTINE CHQ(N,PROB,DXX,CHI)
IMPLICIT REAL*8(A-H,O-Z)
DOF = N
DOF2 = DOF/2.0
DOF1 = DOF2-1.0
GAM = GAMMA(DOF2)
DM = (2.0**DOF2)*GAM
TEST = 1.0E-11
SUM = 0.0
K = 0
X1 = 0.00
IF(DOF.EQ.1.0) X1 = 1.0E-15
F1 = (X1**DOF1)*EXP(-X1/2.0)/DM
DX = DXX
210 IF(DOF.EQ.1.0.AND.K.EQ.0) THEN
DX = DXX
IF(X1.LT.1.0E-4) DX = 1.0E-8
IF(X1.LT.1.0E-6) DX = 1.0E-9
IF(X1.LT.1.0E-8) DX = 1.0E-10
IF(X1.LT.1.0E-10) DX = 1.0E-13
ENDIF
DF = PROB-SUM
X2 = X1+DX
F2 = (X2**DOF1)*EXP(-X2/2.00)/DM
DEL = (F1+F2)*(X2-X1)/2.00
IF(DEL.GT.DF) THEN
K = K+1
DX = DX/10.00
GOTO 210
ENDIF
SUM = SUM+DEL
IF(ABS(SUM-PROB).LT.TEST) GOTO 220
X1 = X2
F1 = F2
GOTO 210

```



```

220 CONTINUE
  CHI = X2
250 CONTINUE
300 CONTINUE
  RETURN
  END
CCCC GAMMA FUNCTION
  FUNCTION GAMMA(X)
  IMPLICIT REAL*8(A-H,O-Z)
  PI = 4.0D0*ATAN(1.0)
  Z = X
  IF(X.GE.6.0) GOTO 456
  N = INT(X)
  Z = 6.0-N+X
456 Y = 1.0/(Z*Z)
  ALG = (Z-0.5)*ALOG(Z)+0.5*ALOG(PI*2.0)-Z-(1.0/(12.0*Z))
  & *(((Y/140.0-1.0/105.0)*Y+1.0/30.0)*Y-1.0)
  IF(X.GE.6.0) GOTO 457
  ITE = 6-N
  DO 3 J=1,ITE
  A = X+J-1.0
  ALG = ALG-ALOG(A)
  3 CONTINUE
457 GAMMA = EXP(ALG)
  RETURN
  END

```

Example Input for PISTRE3

```

24-PLY, (42/50/8) BASELINE, AS4/3501-6
24,0,1
  45.,-45.,90.,0.,45.,-45.,0.,0.,45.,-45.,0.,0.,
  45.,-45.,0.,0.,45.,-45.,0.,0.,45.,-45.,90.,0.,
24*1
18700000., 1900000., 800000., 0.3, 0.0052
11000.
.75
80.
1.0
3, 6.0
7.0, 3.50, 3.50, 1.
1.0
1
3000.0
12.0, 15

```

Example Output for PISTRE3

PLEASE ENTER PROBLEM TITLE

LAMINATE DATA INPUTS:

PLEASE ENTER N,KSY AND M

N IS THE NUMBER OF PLYS IN THE LAMINATE
OR HALF OF TOTAL NO. OF PLYS IF SYMMETRIC

KSY IS THE LAMINATE TYPE CODE
KSY=0 FOR SYMMETRIC LAMINATE
M IS THE NUMBER OF MATERIALS IN THE LAMINATE
PLEASE ENTER PLY-ORIENTATION IN DEGREE FOR EACH PLY
PLEASE ENTER MATERIAL CODE FOR EACH PLY
PLEASE ENTER LAMINA PROPERTIES FOR MATERIAL TYPE 1
EL,ET,GLT,NULT,T

LAMINATE PROPERTY SUMMARY:
48-PLY LAMINATE
LAMINATE TYPE: SYMMETRY
NO. OF MATERIALS M = 1

PLY ORIENTATION, THETA (DEGREES)
45. -45. 90. 0. 45. -45. 0. 0. 45. -45. 0. 0.
45. -45. 0. 0. 45. -45. 0. 0. 45. -45. 90. 0.
0. 90. -45. 45. 0. 0. -45. 45. 0. 0. -45. 45.
0. 0. -45. 45. 0. 0. -45. 45. 0. 90. -45. 45.

MATERIAL CODES
1 1 1 1 1 1 1 1 1 1 1 1
1 1 1 1 1 1 1 1 1 1 1 1
1 1 1 1 1 1 1 1 1 1 1 1
1 1 1 1 1 1 1 1 1 1 1 1

TYPE EL ET GLT NULT T
1 .18700E+08 .19000E+07 .80000E+06 .30000E+00 .0052

SKIN A-MATRIX:
A11 = .278702E+07 A12 = .656500E+06 A22 = .137636E+07
A16 = -.206590E-11 A26 = .161240E-10 A66 = .712595E+06

SKIN MODULUS:
EX = .991138E+07 EY = .489470E+07 GXY = .285495E+07
MAJOR POISSON RATIO VXY = .4770
THEORETICAL MAJOR Kt FOR CIRCULAR HOLE = 3.2629
SKIN THICKNESS T = .2496

IMPACT AND FAILURE PARAMETER INPUTS:
PLEASE ENTER SKIN FAILURE STRAIN IN MICROIN/IN
PLEASE ENTER TOUGHNESS--GIC
PLEASE ENTER IMPACT ENERGY
PLEASE ENTER IMPACTOR DIAMETER
PLEASE ENTER NUMBER OF SPARS AND SPAR AE IN 10**6
PLEASE ENTER SPAR SPACING AND EDGE WIDTH A1,A2
AND THE CHARACTERISTIC LENGTH FOR FAILURE PREDICTION
PLEASE ENTER EFFECTIVE ENERGY COEFFICIENT, AK
PLEASE ENTER IMPACT EVENT CODE, ID
ID = 1 SINGLE MID-BAY IMPACT
ID = 2 TWO BAYS, MID-BAY IMPACTS
ID = 3 SINGLE NEAR SPAR IMPACT
PLEASE ENTER STRAIN VALUE AT DESIGN ULTIMATE
PLEASE ENTER STRENGTH ALPHA AND SAMPLE SIZE
DEFAULT ALPHA=12.0, N=15

ECHO OF IMPACT AND FAILURE PARAMETERS:

24-PLY, (42/50/8) BASELINE, AS4/3501-6
IMPACTOR DIAMETER D = 1.000
FRACTURE TOUGHNESS GIC = .750
SINGLE MID-BAY IMPACT
IMPACT ENERGY IN FT-LB, E = 80.00
EFFECTIVE ENERGY COEFFICIENT, AK = 1.0000
TOTAL NUMBER OF STIFFENERS IN PANEL, NSP = 3
STIFFNESS OF EACH STIFFENER, AE = .600000E+01
WIDTH OF IMPACTED AND ADJACENT FULL BAY = 7.00
WIDTH OF THE ADJACENT PARTIAL BAY A1 = 3.50
WIDTH OF THE REMOTE PARTIAL BAY A2 = 3.50
FAILURE STRAIN FOR THE UNDAMAGED, UNNOTCHED
SKIN LAMINATE EULT = 11000.
STRAIN FOR DESIGN ULTIMATE, DUL = 3000.

ECHO OF STRENGTH VARIABILITY PARAMETERS:

FOR RELIABILITY COMPUTATION
THE WEIBULL ALPHA = 12.00
FOR A SAMPLE SIZE OF 15

COEFFICIENTS FOR IMPACT PARAMETERS:

LAMINATE LAYUP PARAMETER C1 = .39139
FULL PENETRATION PARAMETER C2 = 3.6534
LAMINATE THICKNESS PARAMETER C3 = 1.00659
MATERIAL TOUGHNESS PARAMETER C4 = 1.00000
IMPACT ENERGY PARAMETER C5 = 1.07134
PANEL WIDTH PARAMETER WE = 2.01609
ENERGY CUTOFF = 67.45
ENERGY-THRESHOLD = 6.74
RESIDUAL STRENGTH RATIO = .2567
ENERGY E = 80.00
INITIAL FAILURE STRAIN = 2823.
FINAL FAILURE STRAIN = 3681.
STRAIN AT DUL = 3000.

FOR DAMAGE TOLERANCE DESIGN REQUIREMENT NO. 1
NO CATASTROPHIC STRUCTURAL FAILURE AT DUL

B-BASIS ALLOWABLE STRAIN = 3086. M.S. = .03
A-BASIS ALLOWABLE STRAIN = 2537. M.S. = -.15

FOR DAMAGE TOLERANCE DESIGN REQUIREMENT NO. 2

NO CATASTROPHIC STRUCTURAL FAILURE AT MSL=1.2DLL

B-BASIS ALLOWABLE STRAIN = 3857. M.S. = .29
A-BASIS ALLOWABLE STRAIN = 3171. M.S. = .06

FOR DAMAGE TOLERANCE DESIGN REQUIREMENT NO. 3

NO INITIAL FAILURE AT DLL AND NO CATASTROPHIC
STRUCTURAL FAILURE AT MSL

B-BASIS ALLOWABLE STRAIN = 3550. M.S. = .18
A-BASIS ALLOWABLE STRAIN = 2919. M.S. = -.03

FOR DAMAGE TOLERANCE DESIGN REQUIREMENT NO. 4

NO INITIAL/LOCAL FAILURE AT DLL

B-BASIS ALLOWABLE STRAIN = 2367. M.S. = -.21
A-BASIS ALLOWABLE STRAIN = 1946. M.S. = -.35

RELIABILITY AT DUL: IF = .16304 FF = .92758
 RELIABILITY AT MSL: IF = .88281 FF = .99485
 RELIABILITY AT DLL: IF = .98612 FF = .99942
 Stop - Program terminated.

PISTRE4 Program Listing

```

  IMPLICIT REAL*8(A-H,O-Z)
  DIMENSION TITLE(18)
  COMMON /LAM/ A11,A12,A22,A16,A26,A66
  AVAL = 0.990
  BVAL = 0.900
  TEST = 1.0E-06
  PL = 0.95
  DPL = 0.01
  WRITE(*,*) ' PLEASE ENTER PROBLEM TITLE'
CC INPUT A TITLE FOR THE PROBLEM
  READ(*,1) TITLE
CC INPUT OF LAMINA PROPERTIES FOR STIFFNESS OF THE SKIN VIA LAMAD.
  CALL LAMAD(A11,A12,A22,A16,A26,A66,ESK,T,AKT,EL)
  WRITE(*,*) '
  WRITE(*,*) ' IMPACT AND FAILURE PARAMETER INPUTS:'
  WRITE(*,*) ' PLEASE ENTER SKIN FAILURE STRAIN IN MICROIN/IN'
CC INPUT OF FAILURE STRAIN FOR THE LAMINATE MATERILA, EULT
  READ(*,*) EULT
  WRITE(*,*) ' PLEASE ENTER TOUGHNESS--GIC'
CC INPUT OF FRACTURE TOUGHNESS, GIC
  READ(*,*) GIC
  WRITE(*,*) ' PLEASE ENTER IMPACTOR DIAMETER '
CC INPUT OF IMPACTOR DIAMETER, D
  READ(*,*) D
  WRITE(*,*) ' PLEASE ENTER NUMBER OF SPARS AND SPAR AE IN 10**6'
CC INPUT NUMBER OF STIFFNER AND AE FOR STIFFNER
  READ(*,*) NSP,AE
  WRITE(*,*) ' PLEASE ENTER SPAR SPACING AND EDGE WIDTH A1,A2'
  WRITE(*,*) ' AND THE CHARACTERISTIC LENGTH FOR FAILURE PREDICTION'
CC INPUT STIFFNER SPACING, B, WIDTH OF THE ADJACENT PARTIAL BAY, A1,
CC   AND WIDTH OF THE REMOTE PARTIAL BAY, A2.
  READ(*,*) B2,A1,A2,A0
  WRITE(*,*) ' PLEASE ENTER EFFECTIVE ENERGY COEFFICIENT, AK'
CC INPUT AN EFFECTIVE ENERGY COEFFICIENT, AK.
  READ(*,*) AK
  WRITE(*,*) ' PLEASE ENTER IMPACT EVENT CODE, ID'
  WRITE(*,*) ' ID = 1 SINGLE MID-BAY IMPACT'
  WRITE(*,*) ' ID = 2 TWO BAYS, MID-BAY IMPACTS'
  WRITE(*,*) ' ID = 3 SINGLE NEAR SPAR IMPACT'
CC INPUT IMPACT LOCATION CODE, ID.
  READ(*,*) ID
  WRITE(*,*) ' PLEASE ENTER STRAIN VALUE AT DESIGN ULTIMATE'
CC INPUT STRAIN LEVEL AT DESIGN ULTIMAT LOAD, DUL.
  READ(*,*) DUL
CC INPUT WEIBULL SHAPE PARAMETER AND SAMPLE SIZE FOR
CC RELIABILITY COMPUTATION, DEFAULT ALP=12, NSAMPLE=15
  WRITE(*,*) ' PLEASE ENTER LAMINATE STRENGTH VARIABILITY'

```

```

WRITE(*,*) ' ALPHA AND SAMPLE SIZE'
WRITE(*,*) ' DEFAULT ALPHA=12.0, NSAML=15'
READ(*,*) ALIP,NSAML
IF(ALIP.EQ.0.0) ALIP=12.0
IF(NSAML.EQ.0) NSAML=15
ARG1 = 1.0+1.0/ALIP
GAM = GAMMA(ARG1)
N2 = 2*NSAML
CALL CHQ(N2,PL,DPL,CHIL)
CHI = CHIL/N2
WRITE(*,*) ' PLEASE ENTER STRUCTURAL STRENGTH VARIABILITY'
WRITE(*,*) ' ALPHA AND SAMPLE SIZE'
WRITE(*,*) ' DEFAULT ALPHA=15.0, NSAMS=15'
READ(*,*) ALIS,NSAMS
IF(ALIS.EQ.0.0) ALIS=15.0
IF(NSAMS.EQ.0) NSAMS=15
ARG1 = 1.0+1.0/ALIS
GAMS = GAMMA(ARG1)
N2 = 2*NSAMS
CALL CHQ(N2,PL,DPL,CHR)
CHIS = CHR/N2
CC DISCRETE ENERGY LEVEL IS REPLACED BY DISTRIBUTED THREAT.
CC INPUT IMPACT THREAT AS A DISTRIBUTED FUNCTION
CC A TWO-PARAMETER WEIBULL DISTRIBUTION IS USED IN THE MODEL.
WRITE(*,*) ' PLEASE ENTER IMPACT THREAT DISTRIBUTION PARAMETERS:'
WRITE(*,*) ' MODAL IMPACT ENERGY, XM?'
READ(*,*) XM
WRITE(*,*) ' ENERGY LEVEL WITH LOW PROBABILITY, XP'
READ(*,*) XP
WRITE(*,*) ' THE ASSOCIATED PROBILITY, P'
READ(*,*) P
WRITE(*,*) ' SAMPLE SIZE FOR DISTRIBUTION'
READ(*,*) NTHR
CC DEFINE IMPACT DISTRIBUTION FROM INPUT PARAMETERS
CC USE AN ITERATION SCHEME TO OBTAIN WEIBULL PARAMETERS.
NTHR2 = 2*NTHR
CALL CHQ(NTHR2,PL,DPL,CHIT)
CHIT = CHIT/NTHR2
AL1 = 2.0
AA = -ALOG(P)
XR = XM/XP
XRL = ALOG(XR)
301 RAT = (AL1-1.0)/(AL1*AA)
RA = ALOG(RAT)
AL2 = RA/XRL
ERR = AL2/AL1-1.0
ERR = ABS(ERR)
IF(ERR.LT.TEST) GOTO 300
AL1 = (AL1+AL2)/2.0
IF(AL1.LE.1.0) GOTO 310
GOTO 301
310 AL0 = 2.0
DA = 0.10
DRR = 1.0
313 F = (AL0-1.0)/(AL0*AA)

```

```

FR = F**(1.0/AL0)
R = FR/XR
DR = R-1.0
ADR = ABS(DR)
IF(ADR.LT.TEST) GOTO 312
ADR = DR/DRR
IF(ADR.LT.0.0) DA=DA/2.0
DRR = DR
IF(DR.GT.0.0) GOTO 314
AL0 = AL0+DA
GOTO 313
314 AL0 = AL0-DA
AL01 = ABS(AL0-1.0)
IF(AL01.LT.TEST) GOTO 315
GOTO 316
315 DA = DA/2.0
AL0 = AL0+DA
316 GOTO 313
312 AL = AL0
GOTO 311
300 AL = (AL1+AL2)/2.0
311 BB = AA**(1.0/AL)
BET = XP/BB
WRITE(*,*)'
WRITE(*,*)'
WRITE(*,*)' ECHO OF IMPACT AND FAILURE PARAMETERS:'
WRITE(*,2) TITLE
WRITE(*,3) D,GIC
IF(ID.EQ.1.OR.ID.GT.3) WRITE(*,4)
IF(ID.EQ.2) WRITE(*,5)
IF(ID.EQ.3) WRITE(*,6)
WRITE(*,7) AK
WRITE(*,8) NSP,AE
WRITE(*,9) B2,A1,A2
WRITE(*,10) EULT,DUL
WRITE(*,*)'
WRITE(*,*)' ECHO OF STRENGTH VARIABILITY PARAMETERS:'
WRITE(*,11) ALIP,ALIS
WRITE(*,*)'
WRITE(*,*)' ECHO OF IMPACT THREAT PARAMETERS:'
WRITE(*,12) XM,XP,P,AL,BET
B = B2/2.
AB2 = A2+B2
W = A1+A2+2.0*B2
TE = T*ESK
SAE = TE*W+SN*AE
PE = ESK/EL
AFP = 0.010
ACOF = 0.10
CC C1 IS THE LAMINATE LAYUP PARAMETER.
C1 = 0.54671*(PE**0.52647)
CC C2 IS THE FULL PENETRATION STRESS CONCENTRATION PARAMETER.
CC C2 IS COMPUTED FOR AN ELLIPTICAL HOLE WITH MAJOR AXIS EQUAL TO
CC 1.2 TIMES IMPACTOR DIAMETER AND MINOR AXIS EQUAL TO THE
CC IMPACTOR DIA. THE ASPECT RATIO FOR THE ELLIPSE IS TO ACCOUNT

```

```

CC FOR THE IRREGULAR SHAPE OF THE IMPACT PENETRATION.
  RDA = D/2.0
  RDB = 1.20*RDA
  CALL LEKHOLE(AFP,RDA,RDB,C2)
CC C3 IS THE LAMINATE THICKNESS PARAMETER.
  C3 = 0.499/(T**0.5056)
CC C4 IS THE MATERIAL TOUGHNESS PARAMETER.
CC C5 IS THE IMPACT ENERGY PARAMETER.
CC ENERGY AND TOUGHNESS INTERACTION IS ASSUMED.
  C4 = 1.0
  A4 = 0.07486/GIC+0.01448
  GC = GIC
  IF(GIC.GT.5.554) GC=5.554
  B4 = (-0.00981*GC+0.10897)*GC+0.43449
CC  C5 = A4*(AK*E)**B4
CC WE IS IMPACTOR SIZE PARAMETER
  WF = 2.*(A1+B)
  WR = 1.0-D/WF
  WE = (2.0+WR**3.0)/WR-1.0
CC  CTOT = C1*C2*C3*C4*C5*WE
  TOT = C1*C2*C3*C4*WE
CC  RESN = 1.0/(1.0+CTOT)
  WRITE(*,*)'
  WRITE(*,*)'
  WRITE(*,*)' COEFFICIENTS FOR IMPACT PARAMETERS:'
  WRITE(*,13) C1
  WRITE(*,14) C2
  WRITE(*,15) C3
  WRITE(*,16) C4
CC  WRITE(*,35) C5
  WRITE(*,17) WE
CC COMPUTE THE CUTOFF STRENGTH BASED ON THE AVERAGE STRESS
CC CRITERION AND A TRAPEZOIDAL DAMAGE ZONE THROUGH THE THICKNESS
CC ASSUMPTION. AN ELLIPTICAL HOLE WITH AN ASPECT RATIO IS ALSO APPLIED.
  DDAM = D+6.0*T
  RDAMA = DDAM/2.0
  RDAMB = 1.50*RDAMA
  CALL LEKHOLE(ACOF,RDAMA,RDAMB,AVES)
  AVF = 1.0/AVES
CC AVF IS THE CUTOFF STRENGTH REDUCTION.
CC ESTIMATE CUTOFF ENERGY AND THRESHOLD ENERGY
CC THE CUTOFF ENERGY IS BASED ON THE THROUGH PENETRATION CRITERION
CC THE RESIDUAL STRENGTH REMAINS CONSTANT WITH IMPACT ENERGY EXCEEDS
CC THE CUTOFF.
CC THE THRESHOLD ENERGY IS 0.1 OF THE CUTOFF OR 20 FT-LB WHICHEVER IS
CC LOWER.
  CTCUT = 1.0/AVF-1.0
  C5CUT = CTCUT/(C1*C2*C3*C4*WE)
  ECUT = C5CUT/A4
  ECUT = (ECUT)**(1.0/B4)
  ECUT = ECUT/AK
  ETHRE = ECUT/10.0
  IF (ETHRE.GT. 20.0) ETHRE = 20.0
CC THE STRUCTURAL CONFIGURATION EFFECTS IN THE ORIGINAL MODEL WAS
CC EMPIRICALLY INCORPORATED. THE CURRENT VERSION USES LEKHNISKII

```

CC SOLUTION COMBINED WITH A AVERAGE STRAIN CRITERION.
 CC THE FAILURE STRAIN IS COMPUTED USING THE AVERAGE STRAIN CRITERION.
 CC THE CHARACTERISTIC LENGTH A0 IS AN INPUT PARAMETER AND THERE
 CC IS NO EMPIRIC CONSTANT FOR THE STRAIN DISTRIBUTION.

```

SN = NSP
IF(ID.EQ.2.OR.ID.EQ.3) GOTO 250
AI = AMIN1(A0,A1)
CALL LEKHOLE(AI,D,B,CONST)
ELIM = EULT/CONST
CALL LEKHOLE(A1,D,B,CON1)
CON1 = TE*A1*CON1
CALL LEKHOLE(AB2,D,B,CON2)
CON2 = TE*AB2*CON2
CON4 = SN*AE
FAC = CON1+CON2+CON4
PFL = ELIM*FAC
GOTO 100
250 CON4 = SN*AE
AI = AMIN1(A0,A1,A2)
D2 = 2.0*D
CALL LEKHOLE(AI,D2,B2,CONST)
ELIM = EULT/CONST
CALL LEKHOLE(A1,D2,B2,CON1)
CON1 = TE*A1*CON1
CALL LEKHOLE(A2,D2,B2,CON2)
CON2 = TE*A2*CON2
FAC = CON1+CON2+CON4
PFL = ELIM*FAC
100 CONTINUE
CC SAE IS THE TOTAL PANEL STIFFNESS, AE
CC PFL IS THE TOTAL PANEL FAILURE LOAD BASED ON THE MODEL.
CC EFF IS THE ESTIMATED MINIMUM FAILURE STRAIN
EFF = PFL/SAE
WRITE(*,18) EFF
DMS = DUL/1.25
DLL = DUL/1.5
CC COMPUTE THE 95% CONFIDENT STRUCTURAL FAILURE STRAIN BETA
CC UNBIASED ESTIMATE OF BETA, STRUCTURAL STRAIN
BETSC = EFF/GAMS
CC 95% CONFIDENCE BETA, STRUCTURAL STRAIN
BETSL = BETSC/(CHIS**(1.0/ALIS))
CC SETTING UP STRAIN VALUES FOR RELIABILITY CALCULATIONS.
ES = 0.15*EULT
DES = 100.0
IDS = ES/DES
ES = IDS*DES
MDLL = DLL/DES
IF(ES.GE.DLL) ES = (MDLL-2)*DES
EMAX = 0.8*EULT
IKMA = 0
IKMB = 0
IKSA = 0
IKSB = 0
IDUL = 0
IMSL = 0

```



```

IDLL = 0
WRITE(*,19)
DEN = 2.0
DEN2 = 1.0
155 SUM = 0.0
SUML = 0.0
SUS = 0.0
SUSL = 0.0
PMS = EXP(-(ES/BETSC)**ALIS)
PMLS = EXP(-(ES/BETSL)**ALIS)
EN = 1.0
EN1 = EN-DEN2
PEN1 = EXP(-(EN1/BET)**AL)
153 EN2 = EN+DEN2
PEN2 = EXP(-(EN2/BET)**AL)
EEF = AK*EN
C5 = A4*(EEF)**B4
CTOT = C5*TOT
RES = 1.0/(1.0+CTOT)
CC FOR ENERGY LEVEL GREATER THAN ECUT, THE RESIDUAL STRENGTH
CC IS A FUNCTION OF DAMAGE SIZE ONLY.
CC FOR ENERGY LEVEL BETWEEN ECUT AND 2.0*ECUT THE EFFECTIVE DAMAGE SIZE
CC IS A FUNCTION OF GIC AND FOR ENERGY GREATER THAN 2.0*ECUT
CC THE DAMAGE SIZE IS CONSTANT.
IF (EN.GT.ECUT) THEN
DMAT = 1.0/GIC
DRES = DDAM+(EN-ECUT)*DMAT/ECUT
IF(EN.GT.(2.0*ECUT)) DRES = DDAM+DMAT
RRESA = DRES/2.0
RRESB = 1.50*RRESA
CALL LEKHOLE(ACOF,RRESA,RRESB,AVES)
RES = 1.0/AVES
END IF
IF (EN.LT.ETHRE) RES = 1.0
ESM = RES*EULT
CC ESTIMATE THE RESIDUAL STRENGTH DISTRIBUTION
CC UNBAISED ESTIMATE OF WEIBULL BETA
BETS = ESM/GAM
CC 95% CONFIDENT BETA
BETL = BETS/(CHI**(1.0/ALIP))
PM = EXP(-(ES/BETS)**ALIP)
PML = EXP(-(ES/BETL)**ALIP)
DELTP = PM *(PEN1-PEN2)
DELTL = PML*(PEN1-PEN2)
DELS = DELTP
IF(EFF.GT.ESM) DELS = PMS*(PEN1-PEN2)
DELSL = DELTL
IF(EFF.GT.ESM) DELSL = PMLS*(PEN1-PEN2)
SUM = SUM +DELTP
SUML = SUML+DELTL
SUS = SUS +DELS
SUSL = SUSL+DELSL
IF(DELS.LT.TEST.AND.DELSL.LT.TEST) GOTO 152
EN = EN+DEN
PEN1 = PEN2

```

```

GOTO 153
152 CONTINUE
WRITE(*,20) ES,SUML,SUSL
IF(SUML.GE.AVAL) ECA = ES
IF(SUML.GE.AVAL) PECA = SUML
IF(SUSL.GE.AVAL) ESA = ES
IF(SUSL.GE.AVAL) PESA = SUSL
IF(SUML.GE.BVAL) ECB = ES
IF(SUML.GE.BVAL) PECB = SUML
IF(SUSL.GE.BVAL) ESB = ES
IF(SUSL.GE.BVAL) PESB = SUSL
IF(SUML.LT.AVAL) IKMA = IKMA+1
IF(SUSL.LT.AVAL) IKSA = IKSA+1
IF(SUML.LT.BVAL) IKMB = IKMB+1
IF(SUSL.LT.BVAL) IKSB = IKSB+1
IF(IKMA.EQ.1) ECA1 = ES
IF(IKMA.EQ.1) PECA1 = SUML
IF(IKSA.EQ.1) ESA1 = ES
IF(IKSA.EQ.1) PESA1 = SUSL
IF(IKMB.EQ.1) ECB1 = ES
IF(IKMB.EQ.1) PECB1 = SUML
IF(IKSB.EQ.1) ESB1 = ES
IF(IKSB.EQ.1) PESB1 = SUSL
IF(ES.LT.DLL) GOTO 51
IDLL = IDLL+1
IF(ES.LT.DMS) GOTO 52
IMSL = IMSL+1
IF(ES.LT.DUL) GOTO 53
IDUL = IDUL+1
GOTO 50
51 PDLLI = SUML
PDLLF = SUSL
DLL1 = ES
GOTO 50
52 PMSLI = SUML
PMSLF = SUSL
DMS1 = ES
GOTO 50
53 PDULI = SUML
PDULF = SUSL
DUL1 = ES
50 CONTINUE
IF(IDLL.EQ.1) GOTO 61
IF(IMSL.EQ.1) GOTO 62
IF(IDUL.EQ.1) GOTO 63
GOTO 60
61 PDLLI1 = SUML
PDLLF1 = SUSL
DLL2 = ES
GOTO 60
62 PMSLI1 = SUML
PMSLF1 = SUSL
DMS2 = ES
GOTO 60
63 PDULI1 = SUML

```

```

PDULF1 = SUSL
DUL2 = ES
60 CONTINUE
IF(ES.GT.EMAX) GOTO 154
ES = ES+DES
GOTO 155
154 CONTINUE
ALLIF = ECA+DES*(AVAL-PECA)/(PECA1-PECA)
ALLFF = ESA+DES*(AVAL-PESA)/(PESA1-PESA)
BLLIF = ECB+DES*(BVAL-PECB)/(PECB1-PECB)
BLLFF = ESB+DES*(BVAL-PESB)/(PESB1-PESB)
ALLDIF = 1.50*ALLIF
ALLDFF = 1.25*ALLFF
ALLDUL = ALLDIF
BLLDIF = 1.50*BLLIF
BLLDFF = 1.25*BLLFF
BLLDUL = BLLDIF
IF(ALLDFF.LT.ALLDIF) ALLDUL = ALLDFF
IF(BLLDFF.LT.BLLDIF) BLLDUL = BLLDFF
AMS = ALLFF/DUL-1.0
BMS = BLLFF/DUL-1.0
WRITE(*,21)
WRITE(*,22) BLLFF,BMS,ALLFF,AMS
AMS = ALLDFF/DUL-1.0
BMS = BLLDFF/DUL-1.0
WRITE(*,23)
WRITE(*,22) BLLDFF,BMS,ALLDFF,AMS
AMS = ALLDUL/DUL-1.0
BMS = BLLDUL/DUL-1.0
WRITE(*,24)
WRITE(*,22) BLLDUL,BMS,ALLDUL,AMS
AMS = ALLIF/DUL-1.0
BMS = BLLIF/DUL-1.0
WRITE(*,25)
WRITE(*,22) BLLIF,BMS,ALLIF,AMS
RDULI = PDULI+(PDULI1-PDULI)*(DUL-DUL1)/DES
RDULF = PDULF+(PDULF1-PDULF)*(DUL-DUL1)/DES
RMSLI = PMSLI+(PMSLI1-PMSLI)*(DMS-DMS1)/DES
RMSLF = PMSLF+(PMSLF1-PMSLF)*(DMS-DMS1)/DES
RDLLI = PDLLI+(PDLLI1-PDLLI)*(DLL-DLL1)/DES
RDLLF = PDLLF+(PDLLF1-PDLLF)*(DLL-DLL1)/DES
WRITE(*,26) RDULI,RDULF,RMSLI,RMSLF,RDLLI,RDLLF
1 FORMAT(18A4)
2 FORMAT(/1X,18A4)
3 FORMAT(2X,'IMPACTOR DIAMETER'          D = ',F7.3
& /2X,'FRACTURE TOUGHNESS'             GIC = ',F7.3)
4 FORMAT(2X,'SINGLE MID-BAY IMPACT')
5 FORMAT(2X,'TWO BAYS MID-BAY IMPACTS')
6 FORMAT(2X,'SINGLE NEAR SPAR IMPACT')
7 FORMAT(2X,'EFFECTIVE ENERGY COEFFICIENT,   AK = ',F7.3)
8 FORMAT(2X,'TOTAL NUMBER OF STIFFENERS IN PANEL, NSP = ',I7,
& /2X,'STIFFNESS OF EACH STIFFENER,   AE = ',F7.3)
9 FORMAT(2X,'WIDTH OF IMPACTED AND ADJACENT FULL BAY = ',F7.3,
& /2X,'WIDTH OF THE ADJACENT PARTIAL BAY  A1 = ',F7.3,
& /2X,'WIDTH OF THE REMOTE PARTIAL BAY  A2 = ',F7.3)

```

```

10 FORMAT(2X,'FAILURE STRAIN FOR THE UN DAMAGED, UNNOTCHED'
& /2X,'SKIN LAMINATE          EULT =',F12.0,
& /2X,'STRAIN FOR DESIGN ULTIMATE,    DUL =',F12.0)
11 FORMAT(/2X,'FOR RELIABILITY COMPUTATION',
& /2X,'THE LAMINATE STRENGTH WEIBULL ALPHA =',F7.3,
& /2X,'THE STRUCTURAL STRENGTH WEIBULL ALPHA =',F7.3)
12 FORMAT(/2X,'IMPACT THREAT DISTRIBUTION PARAMETERS:',
& /2X,'MODAL IMPACT ENERGY      XM =',F7.2,
& /2X,'AT ENERGY LEVEL OF      XP =',F7.2,
& /2X,'THE PROBABILITY OF OCCURRENCE  P =',F12.6,
& /2X,'THE WEIBULL SHAPE PARAMETER  ALPHA =',F9.4,
& /2X,'THE WEIBULL SCALE PARAMETER  BETA =',F9.4)
13 FORMAT(2X,'LAMINATE LAYUP PARAMETER  C1 =',F12.5)
14 FORMAT(2X,'FULL PENETRATION PARAMETER  C2 =',F12.5)
15 FORMAT(2X,'LAMINATE THICKNESS PARAMETER C3 =',F12.5)
16 FORMAT(2X,'MATERIAL TOUGHNESS PARAMETER C4 =',F12.5)
17 FORMAT(2X,'PANEL WIDTH THE PARAMETER  WE =',F12.5)
18 FORMAT(/2X,'FINAL STRUCTURAL FAILURE STRAIN GT ',F8.0)
19 FORMAT(/8X,'STRAIN REL.(COUPON) REL.(STRUCTURE)',
& /8X,'_____')
20 FORMAT(5X,F10.0,5X,F9.6,10X,F9.6)
21 FORMAT(/2X,'FOR DAMAGE TOLERANCE DESIGN REQUIREMENT NO. 1',
& /2X,'NO CATASTROPHIC STRUCTURAL FAILURE AT DUL')
22 FORMAT(5X,'B-BASIS ALLOWABLE STRAIN =',F12.0,2X,'M.S. =',F7.2
& /5X,'A-BASIS ALLOWABLE STRAIN =',F12.0,2X,'M.S. =',F7.2)
23 FORMAT(/2X,'FOR DAMAGE TOLERANCE DESIGN REQUIREMANT NO. 2',
& /2X,'NO CATASTROPHIC STRUCTURAL FAILURE AT MSL=1.25DLL')
24 FORMAT(/2X,'FOR DAMAGE TOLERANCE DESIGN REQUIREMANT NO. 3',
& /2X,'NO INITIAL FAILURE AT DLL AND NO CATASTROPHIC '
& /2X,'STRUCTURAL FAILURE AT MSL')
25 FORMAT(/2X,'FOR DAMAGE TOLERANCE DESIGN REQUIREMANT NO. 4',
& /2X,'NO INITIAL/LOCAL FAILURE AT DLL')
26 FORMAT(/2X,'RELIABILITY AT DUL: IF =',F12.5,2X,'FF =',F12.5,
& /2X,'RELIABILITY AT MSL: IF =',F12.5,2X,'FF =',F12.5,
& /2X,'RELIABILITY AT DLL: IF =',F12.5,2X,'FF =',F12.5)
CC 9 FORMAT(2X,'ENERGY          E =',F7.2,
CC & /5X,'INITIAL FAILURE STRAIN =',F12.0,
CC & /5X,'FINAL FAILURE STRAIN =',F12.0,
CC & /5X,'STRAIN AT DUL    =',F12.0)
CC 16 FORMAT(2X,'FOR THE CHARACTERISTIC LENGTH ACOF =',F7.4,
CC & /2X,'THE AVERAGE STRESS FACTOR IS',F9.4)
CC 17 FORMAT(2X,'ENERGY CUTOFF =',F12.2,
CC & /2X,'ENERGY-THRESHOLD =',F12.2,
CC & /2X,'RESIDUAL STRENGTH RATIO =',F9.4)
CC 21 FORMAT(2X,'IMPACT ENERGY IN FT-LB,          E =',F7.2)
110 STOP
END
SUBROUTINE LEKHOLE(A0,A,B,AVFS)
IMPLICIT REAL*8(A-H,O-Z)
COMPLEX*16 EU1,EU2,Z1,Z2,Z12,Z22
COMPLEX*16 SI1,SI2,SI1R,SI2R,EU12,EU22
COMPLEX*16 F1,F2,F1I,F2I
COMPLEX*16 EYE,BET,FORCE1,FORCE2,PH1P,PH2P
COMPLEX*16 G,GP,RT,RT2,C0,C1,C2,C3,C4,CP1,CP2,CP3,C,AC,BC,AMU
DIMENSION AA(3,3),AVES(501)

```

```

COMMON /LAM/ A11,A12,A22,A16,A26,A66
CC THE APPLIED FORCE IS A UNIT STRESS IN THE X-DIRECTION
CC OR P = 1.0, Q = 0.0, T = 0.0
EYE = (0.0, 1.0)
PI = 4.0*ATAN(1.0)
PI2 = PI/2.0
NK = 50
IF(A0.EQ.0.0) GOTO 50
FNK = DFLOAT(NK)
DYB = A0/FNK
IF(DYB.GT.0.01) DYB = 0.01
FNK = A0/DYB+0.2
NK = FNK
IF(NK.GT.500) NK = 500
DYB = A0/NK
NK1 = NK+1
50 A2 = A*A
B2 = B*B
ESP = 0.000001
AA(1,1) = A11
AA(1,2) = A12
AA(2,1) = A12
AA(1,3) = A16
AA(3,1) = A16
AA(2,2) = A22
AA(2,3) = A26
AA(3,2) = A26
AA(3,3) = A66
CALL MINV(3,AA)
IF((AA(1,3).EQ.0.0).AND.(AA(2,3).EQ.0.0)) GOTO 140
C4 = AA(1,1)
C3 = -2.0*AA(1,3)
C2 = 2.0*AA(1,2)+AA(3,3)
C1 = -2.0*AA(2,3)
C0 = AA(2,2)
RT = (0.0, 0.0)
DO 120 I=1,300
G = C4*RT**4.0+C3*RT**3.0+C2*RT*RT+C1*RT+C0
GP = 4.0*C4*RT**3.0+3.0*C3*RT*RT+2.0*C2*RT+C1
IF(CDABS(G) .LT.1.0E-10) GOTO 130
IF(CDABS(GP).EQ.0.0) GOTO 121
GOTO 122
121 WRITE(*,*) 'THE LAMINATE HAS A SINGULAR CHARAC. EQUATION!'
STOP
122 RT = RT-G/GP
120 CONTINUE
130 SP1 = -(RT+DCONJG(RT))
SP0 = RT*DCONJG(RT)
CP1 = C4
CP2 = C3-SP1*C4
CP3 = (C2-C4*SP0)-SP1*CP2
RT2 = (-CP2+(CP2*CP2-4.0*CP1*CP3)**0.5)/(2.0*CP1)
EU1 = DCMLPX(DREAL(RT),DABS(DIMAG(RT)))
EU2 = DCMLPX(DREAL(RT2),DABS(DIMAG(RT2)))
GOTO 150

```

```

140 BC = 2.0*AA(1,2)+AA(3,3)
   AC = AA(1,1)
   C = AA(2,2)
   AMU = BC*BC-4.0*AC*C
   ZX = DREAL(AMU)
   ZY = DIMAG(AMU)
   THO = ATAN(ZY/ZX)
   CALL ROOT(THO,ZX,ZY,AMUR,AMUI)
   EU1 = -BC+DCMPLX(AMUR,AMUI)
   EU1 = EU1/(2.0*AA(1,1))
   ZX = DREAL(EU1)
   ZY = DIMAG(EU1)
   THO = ATAN(ZY/ZX)
   CALL ROOT(THO,ZX,ZY,XX,YY)
   EU1 = DCMPLX(XX,YY)
   EU2 = -BC-DCMPLX(AMUR,AMUI)
   EU2 = EU2/(2.0*AA(1,1))
   ZX = DREAL(EU2)
   ZY = DIMAG(EU2)
   THO = ATAN(ZY/ZX)
   CALL ROOT(THO,ZX,ZY,XX,YY)
   EU2 = DCMPLX(XX,YY)
   IF(CDABS(EU1-DCONJG(EU2)).LT.1.0E-5) EU2 = -DCONJG(EU1)
150 CONTINUE
   EU12 = EU1*EU1
   EU22 = EU2*EU2
   BET = -EYE*B/2.0
   FORCE1 = -BET*(A-EYE*B*EU1)/(EU1-EU2)
   FORCE2 = BET*(A-EYE*B*EU2)/(EU1-EU2)
   RB = B
   TH = PI2
   KK = 1
110 CONTINUE
   RA = RB*A/B
CC TO CHOOSE THE CORRECT BRANCH IN THE SQUARE ROOTS FOR STRESS
CC SOLUTION, SUBROUTINE 'ROOT1' IS USED AND THE LOWER AND UPPER
CC BOUND OF THE CORRECT CHOICE IS INITIALIZED HERE.
   X = RA
   Y = 0.0
   Z1 = X
   Z2 = X
   Z12 = Z1*Z1
   Z22 = Z2*Z2
   S11 = Z12-A2-B2*EU12
   S12 = Z22-A2-B2*EU22
   SX = REAL(S11)
   SY = AIMAG(S11)
   IF(ABS(SX).LT.ESP) SX=0.0
   IF(ABS(SY).LT.ESP) SY=0.0
   IF(SX.EQ.0.0.AND.SY.GT.0.0) GOTO 701
   IF(SX.EQ.0.0.AND.SY.LT.0.0) GOTO 702
   TH10 = DATAN(SY/SX)
   IF(SX.LT.0.0.AND.SY.GT.0.0) TH10 = PI+TH10
   IF(SX.LT.0.0.AND.SY.LT.0.0) TH10 = TH10-PI
   GOTO 703

```

```

701 TH10 = PI2
   GOTO 703
702 TH10 = -PI2
703 CONTINUE
   TH112 = TH10/2.0
   TH11P = TH112+PI
CC  TH112D = 180.0*TH112/PI
CC  TH11PD = 180.0*TH11P/PI
CC  WRITE(*,70) TH112D,TH11PD
CC  70 FORMAT(2X,'LOWER LIMIT FOR ROOT OF S11 (deg) =',F6.2,
CC  & /2X,'UPPER LIMIT FOR ROOT OF S11 (deg) =',F6.2)
CC  71 FORMAT(2X,'LOWER LIMIT FOR ROOT OF S12 (deg) =',F6.2,
CC  & /2X,'UPPER LIMIT FOR ROOT OF S12 (deg) =',F6.2)
   SX = REAL(SI2)
   SY = AIMAG(SI2)
   IF(ABS(SX).LT.ESP) SX=0.0
   IF(ABS(SY).LT.ESP) SY=0.0
   IF(SX.EQ.0.0.AND.SY.GT.0.0) GOTO 704
   IF(SX.EQ.0.0.AND.SY.LT.0.0) GOTO 705
   TH11 = DATAN(SY/SX)
   IF(SX.LT.0.0.AND.SY.GT.0.0) TH11 = PI+TH11
   IF(SX.LT.0.0.AND.SY.LT.0.0) TH11 = TH11-PI
   GOTO 706
704 TH11 = PI2
   GOTO 706
705 TH11 = -PI2
706 CONTINUE
   TH222 = TH11/2.0
   TH22P = TH222+PI
CC  TH222D = 180.0*TH222/PI
CC  TH22PD = 180.0*TH22P/PI
CC  WRITE(*,71) TH222D,TH22PD
   X = 0.0
   Y = RB
   Z1 = EU1*Y
   Z12 = Z1*Z1
   Z2 = EU2*Y
   Z22 = Z2*Z2
   S11 = Z12-A2-B2*EU12
   S12 = Z22-A2-B2*EU22
   SX = REAL(S11)
   SY = AIMAG(S11)
   IF(ABS(SX).LT.ESP) SX=0.0
   IF(ABS(SY).LT.ESP) SY=0.0
   TH102 = TH112
   TH10P = TH11P
   CALL ROOT1(TH,SX,SY,TH102,TH10P,XX,YY)
CC
CC  TH0 = DATAN(SY/SX)
CC  IF(SX.LT.0.0.AND.SY.GE.0.0) TH0 = PI+TH0
CC  IF(SX.LT.0.0.AND.SY.LT.0.0) TH0 = TH0+PI
CC  IF(SX.GT.0.0.AND.SY.LT.0.0) TH0 = TH0+2.0*PI
CC  CALL ROOT(TH0,SX,SY,XX,YY)
   S11R = CMPLX(XX,YY)
   SX = REAL(SI2)

```

```

SY = AIMAG(SI2)
IF(ABS(SX).LT.ESP) SX=0.0
IF(ABS(SY).LT.ESP) SY=0.0
THI12 = TH222
THI1P = TH22P
CALL ROOT1(TH,SX,SY,THI12,THI1P,XX,YY)
CC TH1 = DATAN(SY/SX)
CC IF(SX.LT.0.0.AND.SY.GE.0.0) TH1 = PI+TH1
CC IF(SX.LT.0.0.AND.SY.LT.0.0) TH1 = TH1+PI
CC IF(SX.GT.0.0.AND.SY.LT.0.0) TH0 = TH1+2.0*PI
CC CALL ROOT(TH1,SX,SY,XX,YY)
SI2R = CMPLX(XX,YY)
F1I = (Z1+SI1R)*SI1R
F2I = (Z2+SI2R)*SI2R
F1 = 1.0/F1I
F2 = 1.0/F2I
PH1P = FORCE1*F1
PH2P = FORCE2*F2
SIGX = 1.0+2.0*REAL(EU12*PH1P+EU22*PH2P)
CC WRITE(*,1) RA,RB,SIGX
CC SIGY = 2.0*REAL( PH1P+ PH2P)
CC SIGXY= -2.0*REAL( EU1*PH1P+ EU2*PH2P)
CC IF A0=0.0 THEN SIGX AT THE HOLE BOUNDARY IS THE ACTUAL Kt
CC THIS IS THE Kt TO BE USED IN COMPUTING THE STRESS CONCENTRATION
CC FACTOR C2, IN THE MODEL.
IF(A0.EQ.0.0) THEN
SUMS = SIGX
GOTO 107
ENDIF
AVES(KK) = SIGX
IF(KK.GE.NK1) GOTO 105
RB = RB+DYB
KK = KK+1
GOTO 110
105 CONTINUE
SUMS = AVES(1)
DO 106 I=2,NK
106 SUMS = SUMS+2.0*AVES(I)
SUMS = SUMS+AVES(NK1)
SUMS = SUMS/(2.0*NK)
107 AVFS = SUMS
1 FORMAT(2X,'RA = ',F7.3,2X,'RB = ',F7.3,2X,'SIGX = ',F9.4)
CC HOLFAC = SUMS/P
999 RETURN
END
SUBROUTINE ROOT(TH0,X,Y,XX,YY)
IMPLICIT REAL*8(A-H,O-Z)
PI = 4.0*ATAN(1.0)
PI4 = PI/4.0
ANI = 0.5
R = X*X+Y*Y
R = SQRT(R)
RN = R**ANI
IF(X.EQ.0.0.AND.Y.GT.0.0) GOTO 10
IF(X.EQ.0.0.AND.Y.LT.0.0) GOTO 15

```



```

TH = ATAN(Y/X)
IF(X.LT.0.0.AND.Y.GE.0.0) TH = PI+TH
IF(X.LT.0.0.AND.Y.LT.0.0) TH = TH+PI
IF(X.GT.0.0.AND.Y.LT.0.0) TH = TH+2.0*PI
GOTO 20
10 TH = PI/2.0
GOTO 20
15 TH = 3.0*PI/2.0
20 THN = TH/2.0
XX = RN*COS(THN)
YY = RN*SIN(THN)
CC THD = ABS(TH-TH0)
CC IF(THD.GE.PI4) THEN
CC XX = -XX
CC YY = -YY
CC TH = TH+PI
CC ENDF
TH0 = TH
RETURN
END
SUBROUTINE ROOT1(TXY,X,Y,TH2,THP,XX,YY)
IMPLICIT REAL*8(A-H,O-Z)
PI = 4.0*ATAN(1.0)
PI4 = PI/4.0
PI2 = 2.0*PI
PI22 = PI/2.0
ANI = 0.5
R = X*X+Y*Y
R = SQRT(R)
RN = R**ANI
IF(TXY.EQ.0.0) THEN
THN = TH2
GOTO 30
ENDIF
IF(TXY.GT.PI) THEN
TH2 = TH2+PI
THP = THP+PI
ENDIF
IF(X.EQ.0.0.AND.Y.GT.0.0) GOTO 10
IF(X.EQ.0.0.AND.Y.LT.0.0) GOTO 15
TH = ATAN(Y/X)
IF(X.LT.0.0.AND.Y.GE.0.0) TH = PI+TH
IF(X.LT.0.0.AND.Y.LT.0.0) TH = TH-PI
GOTO 20
10 TH = PI22
GOTO 20
15 TH = -PI22
20 CONTINUE
IF(TXY.GT.PI) TH = TH+PI2
THN1 = TH/2.0
THN2 = THN1+PI
CC THN1D = 180.0*THN1/PI
CC THN2D = 180.0*THN2/PI
CC WRITE(*,1) THN1D,THN2D
THN = THN1

```

```

IF(THN.LT.TH2.OR.THN.GT.THP) THN = THN2
CC THND = 180.0*THN/PI
CC WRITE(*,2) THND
CC 1 FORMAT(2X,'THE TWO HALF ANGLES ARE: ',2F9.2)
CC 2 FORMAT(2X,'THE CORRECT BRANCH IS : ',2F9.2)
30 XX = RN*COS(THN)
YY = RN*SIN(THN)
RETURN
END
SUBROUTINE MINV(N,A)
IMPLICIT REAL*8(A-H,O-Z)
DIMENSION A(3,3)
DO 1 I=1,N
X = A(I,I)
A(I,I) = 1.0
DO 2 J=1,N
2 A(I,J) = A(I,J)/X
DO 1 K=1,N
IF(K-I) 3,1,3
3 X = A(K,I)
A(K,I) = 0.0
DO 4 J=1,N
4 A(K,J) = A(K,J) -X*A(I,J)
1 CONTINUE
RETURN
END
SUBROUTINE LAMAD(Q11B,Q12B,Q22B,Q16B,Q26B,Q66B,EX,TT,AKT,EL1)
IMPLICIT REAL*8(A-H,O-Z)
DIMENSION TH(150),MTY(150),EL(10),ET(10),GLT(10),PNU(10),T(10)
COMMON /LAM/ A11,A12,A22,A16,A26,A66
PI = 4.0D0*DATAN(1.0D0)
PI2 = PI*PI
WRITE(*,*)'
WRITE(*,*)' LAMINATE DATA INPUTS:'
WRITE(*,1)
READ(*,*) N,KSY,M
WRITE(*,*)' PLEASE ENTER PLY-ORIENTATION IN DEGREE FOR EACH PLY'
READ(*,*) (TH(I), I=1,N)
WRITE(*,*)' PLEASE ENTER MATERIAL CODE FOR EACH PLY'
READ(*,*) (MTY(I),I=1,N)
IF(KSY.NE.0) GOTO 50
DO 51 I=1,N
MTY(N+I) = MTY(N-I+1)
51 TH(N+I) = TH(N-I+1)
N = 2*N
50 CONTINUE
DO 70 I=1,M
WRITE(*,2) I
70 READ(*,*) EL(I),ET(I),GLT(I),PNU(I),T(I)
WRITE(*,*)'
WRITE(*,*)'
WRITE(*,*)' LAMINATE PROPERTY SUMMARY:'
WRITE(*,3) N
IF(KSY.EQ.0) WRITE(*,11)
IF(KSY.NE.0) WRITE(*,12)

```

```

WRITE(*,13) M
WRITE(*,*)'
WRITE(*,*)' PLY ORIENTATION, THETA (DEGREES)'
WRITE(*,4) (TH(J), J=1,N)
WRITE(*,*)'
WRITE(*,*)' MATERIAL CODES'
WRITE(*,5) (MTY(J),J=1,N)
WRITE(*,6)
DO 75 I=1,M
75 WRITE(*,7) I,EL(I),ET(I),GLT(I),PNU(I),T(I)
EL1 = EL(1)
TT = 0.0D0
DO 52 I=1,N
TT = TT+T(MTY(I))
52 TH(I) = TH(I)*PI/1.800D+2
Q11B = 0.0D0
Q12B = 0.0D0
Q22B = 0.0D0
Q66B = 0.0D0
Q16B = 0.0D0
Q26B = 0.0D0
DO 60 I=1,N
TI = T(MTY(I))
P2 = PNU(MTY(I))*PNU(MTY(I))
QT = EL(MTY(I))/(EL(MTY(I))-P2*ET(MTY(I)))
Q11 = EL(MTY(I))*QT
Q22 = ET(MTY(I))*QT
Q12 = PNU(MTY(I))*Q22
Q66 = GLT(MTY(I))
QT1 = Q11+Q22
QT2 = 4.0D0*Q66
QT3 = 2.0D0*Q12
U1 = (3.0D0*QT1+QT3+QT2)/8.0D0
U2 = (Q11-Q22)/2.0D0
U3 = (QT1-QT3-QT2)/8.0D0
U4 = (QT1+3.0D0*QT3-QT2)/8.0D0
U5 = (QT1-QT3+QT2)/8.0D0
U61 = (Q11-Q12-2.0D0*Q66)/8.0D0
U62 = (Q12-Q22+2.0D0*Q66)/8.0D0
TH2 = 2.0D0*TH(I)
TH4 = 4.0D0*TH(I)
CO2 = DCOS(TH2)
CO4 = DCOS(TH4)
CS = 2.0D0*DSIN(TH2)+DSIN(TH4)
SC = 2.0D0*DSIN(TH2)-DSIN(TH4)
Q1 = U1+U2*CO2+U3*CO4
Q2 = U1-U2*CO2+U3*CO4
Q3 = U4-U3*CO4
Q6 = U5-U3*CO4
Q16 = U61*CS+U62*SC
Q26 = U61*SC+U62*CS
Q11B = Q11B+Q1*TI
Q22B = Q22B+Q2*TI
Q12B = Q12B+Q3*TI
Q66B = Q66B+Q6*TI

```

```

Q16B = Q16B+Q16*TI
Q26B = Q26B+Q26*TI
60 CONTINUE
A11 = Q11B
A12 = Q12B
A22 = Q22B
A16 = Q16B
A26 = Q26B
A66 = Q66B
QB = (A11*A22-A12*A12)/TT
EX = QB/A22
EY = QB/A11
GXY = A66/TT
UXY = A12/A22
UYX = A12/A11
AKT = 2.0*(EX/EY-UXY)
AKT = AKT+EX/EY
AKT = 1.0+DSQRT(AKT)
CC AKT IS THE THEORETICAL STRESS CONCENTRATION FACTOR.
WRITE(*,8) A11,A12,A22,A16,A26,A66
WRITE(*,9) EX,EY,GXY,UXY,AKT,TT
1 FORMAT(3X,'PLEASE ENTER N,KSY AND M',
& /8X,'N IS THE NUMBER OF PLYS IN THE LAMINATE'
& /8X,'OR HALF OF TOTAL NO. OF PLYS IF SYMMETRIC',
& /8X,'KSY IS THE LAMINATE TYPE CODE',
& /8X,'KSY=0 FOR SYMMETRIC LAMINATE',
& /8X,'M IS THE NUMBER OF MATERIALS IN THE LAMINATE')
2 FORMAT(3X,'PLEASE ENTER LAMINA PROPERTIES FOR MATERIAL TYPE',I3,
& /8X,'EL,ET,GLT,NULT,T')
3 FORMAT(9X,I3,'-PLY LAMINATE')
11 FORMAT(9X,'LAMINATE TYPE: SYMMETRY')
12 FORMAT(9X,'LAMINATE TYPE: NON-SYMMETRY')
13 FORMAT(9X,'NO. OF MATERIALS M = ',I3)
4 FORMAT(4X,12F5.0)
5 FORMAT(3X,12I5)
6 FORMAT(/3X,'TYPE',2X,'EL',10X,'ET',10X,'GLT',9X,'NULT',8X,'T')
7 FORMAT(4X,I3,4E12.5,F7.4)
8 FORMAT(/3X,'SKIN A-MATRIX:',
& /5X,'A11 = ',E12.6,2X,'A12 = ',E12.6,2X,'A22 = ',E12.6,
& /5X,'A16 = ',E12.6,2X,'A26 = ',E12.6,2X,'A66 = ',E12.6)
9 FORMAT(/3X,'SKIN MODULUS:',
& /5X,'EX = ',E12.6,2X,'EY = ',E12.6,2X,'GXY = ',E12.6,
& /5X,'MAJOR POISSON RATIO VXY = ',F9.4,
& /5X,'THEORETICAL MAJOR Kt FOR CIRCULAR HOLE = ',F9.4
& /5X,'SKIN THICKNESS T = ',F9.4)
RETURN
END
CC USE OF CHISQ AS A SUBROUTINE
CCCC CHI-SQUARE DISTRIBUTION
SUBROUTINE CHQ(N,PROB,DXX,CHI)
IMPLICIT REAL*8(A-H,O-Z)
DOF = N
DOF2 = DOF/2.0
DOF1 = DOF2-1.0
GAM = GAMMA(DOF2)

```

```

DM = (2.0**DOF2)*GAM
TEST = 1.0E-11
SUM = 0.0
K = 0
X1 = 0.00
IF(DOF.EQ.1.0) X1 = 1.0E-15
F1 = (X1**DOF1)*EXP(-X1/2.0)/DM
DX = DXX
210 IF(DOF.EQ.1.0.AND.K.EQ.0) THEN
DX = DXX
IF(X1.LT.1.0E-4) DX = 1.0E-8
IF(X1.LT.1.0E-6) DX = 1.0E-9
IF(X1.LT.1.0E-8) DX = 1.0E-10
IF(X1.LT.1.0E-10) DX = 1.0E-13
ENDIF
DF = PROB-SUM
X2 = X1+DX
F2 = (X2**DOF1)*EXP(-X2/2.00)/DM
DEL = (F1+F2)*(X2-X1)/2.00
IF(DEL.GT.DF) THEN
K = K+1
DX = DX/10.00
GOTO 210
ENDIF
SUM = SUM+DEL
IF(ABS(SUM-PROB).LT.TEST) GOTO 220
X1 = X2
F1 = F2
GOTO 210
220 CONTINUE
CHI = X2
250 CONTINUE
300 CONTINUE
RETURN
END
CCCC GAMMA FUNCTION
FUNCTION GAMMA(X)
IMPLICIT REAL*8(A-H,O-Z)
PI = 4.0D0*ATAN(1.0)
Z = X
IF(X.GE.6.0) GOTO 456
N = INT(X)
Z = 6.0-N+X
456 Y = 1.0/(Z*Z)
ALG = (Z-0.5)*ALOG(Z)+0.5*ALOG(PI*2.0)-Z-(1.0/(12.0*Z))
& *(((Y/140.0-1.0/105.0)*Y+1.0/30.0)*Y-1.0)
IF(X.GE.6.0) GOTO 457
ITE = 6-N
DO 3 J=1,ITE
A = X+J-1.0
ALG = ALG-ALOG(A)
3 CONTINUE
457 GAMMA = EXP(ALG)
RETURN
END

```

Example Input for PISTRE4

RELIABILITY CURVES FOR REGION 8L, F/A-18A WING
100,1,1
47*0.,24*45.,23*-45.,6*90.
100*1
18700000., 1900000., 800000., 0.3, 0.003586
11000.
0.750
1.0
3, 8.12
4.5, 0.5, 20.0 , 1.
1.0
1
2700.0
12.0, 15
15.0, 15
6.0
100.0
0.01
30

Example Output for PISTRE4

PLEASE ENTER PROBLEM TITLE

LAMINATE DATA INPUTS:

PLEASE ENTER N,KSY AND M

N IS THE NUMBER OF PLYS IN THE LAMINATE
OR HALF OF TOTAL NO. OF PLYS IF SYMMETRIC
KSY IS THE LAMINATE TYPE CODE
KSY=0 FOR SYMMETRIC LAMINATE

M IS THE NUMBER OF MATERIALS IN THE LAMINATE
PLEASE ENTER PLY-ORIENTATION IN DEGREE FOR EACH PLY
PLEASE ENTER MATERIAL CODE FOR EACH PLY
PLEASE ENTER LAMINA PROPERTIES FOR MATERIAL TYPE 1
EL,ET,GLT,NULT,T

LAMINATE PROPERTY SUMMARY:

100-PLY LAMINATE
LAMINATE TYPE: NON-SYMMETRY
NO. OF MATERIALS M = 1

PLY ORIENTATION, THETA (DEGREES)

0. 0. 0. 0. 0. 0. 0. 0. 0. 0. 0. 0.
0. 0. 0. 0. 0. 0. 0. 0. 0. 0. 0. 0.
0. 0. 0. 0. 0. 0. 0. 0. 0. 0. 0. 0.
0. 0. 0. 0. 0. 0. 0. 0. 0. 0. 0. 45.
45. 45. 45. 45. 45. 45. 45. 45. 45. 45. 45. 45.
45. 45. 45. 45. 45. 45. 45. 45. 45. 45. 45. -45.
-45. -45. -45. -45. -45. -45. -45. -45. -45. -45. -45. -45.
-45. -45. -45. -45. -45. -45. -45. -45. -45. -45. 90. 90.
90. 90. 90. 90.

MATERIAL CODES

1 1 1 1 1 1 1 1 1 1 1 1
1 1 1 1 1 1 1 1 1 1 1 1
1 1 1 1 1 1 1 1 1 1 1 1
1 1 1 1 1 1 1 1 1 1 1 1
1 1 1 1 1 1 1 1 1 1 1 1
1 1 1 1 1 1 1 1 1 1 1 1
1 1 1 1 1 1 1 1 1 1 1 1
1 1 1 1 1 1 1 1 1 1 1 1
1 1 1 1 1 1 1 1 1 1 1 1
1 1 1 1

TYPE EL ET GLT NULT T
1 .18700E+08 .19000E+07 .80000E+06 .30000E+00 .0036

SKIN A-MATRIX:

A11 = .428139E+07 A12 = .898979E+06 A22 = .178856E+07
A16 = .152002E+05 A26 = .152002E+05 A66 = .979570E+06

SKIN MODULUS:

EX = .106791E+08 EY = .446124E+07 GXY = .273165E+07
MAJOR POISSON RATIO VXY = .5026
THEORETICAL MAJOR Kt FOR CIRCULAR HOLE = 3.4852
SKIN THICKNESS T = .3586

IMPACT AND FAILURE PARAMETER INPUTS:

PLEASE ENTER SKIN FAILURE STRAIN IN MICROIN/IN
PLEASE ENTER TOUGHNESS--GIC
PLEASE ENTER IMPACTOR DIAMETER
PLEASE ENTER NUMBER OF SPARS AND SPAR AE IN 10**6
PLEASE ENTER SPAR SPACING AND EDGE WIDTH A1,A2
AND THE CHARACTERISTIC LENGTH FOR FAILURE PREDICTION
PLEASE ENTER EFFECTIVE ENERGY COEFFICIENT, AK
PLEASE ENTER IMPACT EVENT CODE, ID
ID = 1 SINGLE MID-BAY IMPACT
ID = 2 TWO BAYS, MID-BAY IMPACTS
ID = 3 SINGLE NEAR SPAR IMPACT
PLEASE ENTER STRAIN VALUE AT DESIGN ULTIMATE
PLEASE ENTER LAMINATE STRENGTH VARIABILITY
ALPHA AND SAMPLE SIZE
DEFAULT ALPHA=12.0, NSAML=15
PLEASE ENTER STRUCTURAL STRENGTH VARIABILITY
ALPHA AND SAMPLE SIZE
DEFAULT ALPHA=15.0, NSAMS=15
PLEASE ENTER IMPACT THREAT DISTRIBUTION PARAMETERS:
MODAL IMPACT ENERGY, XM?
ENERGY LEVEL WITH LOW PROBABILITY, XP
THE ASSOCIATED PROBILITY, P
SAMPLE SIZE FOR DISTRIBUTION

ECHO OF IMPACT AND FAILURE PARAMETERS:

RELIABILITY CURVES FOR REGION 8L, F/A-18A WING
IMPACTOR DIAMETER D = 1.000

FRACTURE TOUGHNESS GIC = .750
 SINGLE MID-BAY IMPACT
 EFFECTIVE ENERGY COEFFICIENT, AK = 1.000
 TOTAL NUMBER OF STIFFENERS IN PANEL, NSP = 3
 STIFFNESS OF EACH STIFFENER, AE = 8.120
 WIDTH OF IMPACTED AND ADJACENT FULL BAY = 4.500
 WIDTH OF THE ADJACENT PARTIAL BAY A1 = .500
 WIDTH OF THE REMOTE PARTIAL BAY A2 = 20.000
 FAILURE STRAIN FOR THE UNDAMAGED, UNNOTCHED
 SKIN LAMINATE EULT = 11000.
 STRAIN FOR DESIGN ULTIMATE, DUL = 2700.

ECHO OF STRENGTH VARIABILITY PARAMETERS:

FOR RELIABILITY COMPUTATION
 THE LAMINATE STRENGTH WEIBULL ALPHA = 12.000
 THE STRUCTURAL STRENGTH WEIBULL ALPHA = 15.000

ECHO OF IMPACT THREAT PARAMETERS:

IMPACT THREAT DISTRIBUTION PARAMETERS:
 MODAL IMPACT ENERGY XM = 6.00
 AT ENERGY LEVEL OF XP = 100.00
 THE PROBABILITY OF OCCURRENCE P = .010000
 THE WEIBULL SHAPE PARAMETER ALPHA = 1.1919
 THE WEIBULL SCALE PARAMETER BETA = 27.7685

COEFFICIENTS FOR IMPACT PARAMETERS:

LAMINATE LAYUP PARAMETER C1 = .40707
 FULL PENETRATION PARAMETER C2 = 3.79105
 LAMINATE THICKNESS PARAMETER C3 = .83809
 MATERIAL TOUGHNESS PARAMETER C4 = 1.00000
 PANEL WIDTH PARAMETER WE = 2.11387

FINAL STRUCTURAL FAILURE STRAIN GT 3481.

STRAIN REL.(COUPON) REL.(STRUCTURE)

| | | |
|-------|---------|---------|
| 1600. | .999893 | .999984 |
| 1700. | .999786 | .999974 |
| 1800. | .999582 | .999954 |
| 1900. | .999207 | .999915 |
| 2000. | .998543 | .999843 |
| 2100. | .997405 | .999712 |
| 2200. | .995516 | .999482 |
| 2300. | .992485 | .999084 |
| 2400. | .987801 | .998410 |
| 2500. | .980867 | .997291 |
| 2600. | .971108 | .995465 |
| 2700. | .958148 | .992539 |
| 2800. | .941994 | .987937 |
| 2900. | .923029 | .980838 |
| 3000. | .901721 | .970128 |

| | | |
|-------|---------|---------|
| 3100. | .878298 | .954395 |
| 3200. | .852787 | .932039 |
| 3300. | .825292 | .901628 |
| 3400. | .796086 | .862579 |
| 3500. | .765512 | .816109 |
| 3600. | .733927 | .765869 |
| 3700. | .701682 | .717164 |
| 3800. | .669104 | .674206 |
| 3900. | .636496 | .637403 |
| 4000. | .604131 | .604157 |
| 4100. | .572250 | .572234 |
| 4200. | .541059 | .541057 |
| 4300. | .510737 | .510737 |
| 4400. | .481435 | .481435 |
| 4500. | .453276 | .453276 |
| 4600. | .426367 | .426367 |
| 4700. | .400795 | .400795 |
| 4800. | .376633 | .376633 |
| 4900. | .353944 | .353944 |
| 5000. | .332784 | .332784 |
| 5100. | .313202 | .313202 |
| 5200. | .295242 | .295242 |
| 5300. | .278944 | .278944 |
| 5400. | .264337 | .264337 |
| 5500. | .251445 | .251445 |
| 5600. | .240271 | .240271 |
| 5700. | .230800 | .230800 |
| 5800. | .222986 | .222986 |
| 5900. | .216745 | .216745 |
| 6000. | .211954 | .211954 |
| 6100. | .208448 | .208448 |
| 6200. | .206025 | .206025 |
| 6300. | .204459 | .204459 |
| 6400. | .203520 | .203520 |
| 6500. | .202999 | .202999 |
| 6600. | .202721 | .202721 |
| 6700. | .202561 | .202561 |
| 6800. | .202444 | .202444 |
| 6900. | .202332 | .202332 |
| 7000. | .202207 | .202207 |
| 7100. | .202062 | .202062 |
| 7200. | .201893 | .201893 |
| 7300. | .201696 | .201696 |
| 7400. | .201468 | .201468 |
| 7500. | .201203 | .201203 |
| 7600. | .200897 | .200897 |
| 7700. | .200545 | .200545 |
| 7800. | .200138 | .200138 |
| 7900. | .199671 | .199671 |
| 8000. | .199136 | .199136 |
| 8100. | .198524 | .198524 |
| 8200. | .197824 | .197824 |
| 8300. | .197028 | .197028 |

| | | |
|-------|---------|---------|
| 8400. | .196123 | .196123 |
| 8500. | .195095 | .195095 |
| 8600. | .193933 | .193933 |
| 8700. | .192621 | .192621 |
| 8800. | .191142 | .191142 |
| 8900. | .189480 | .189480 |

FOR DAMAGE TOLERANCE DESIGN REQUIREMENT NO. 1
NO CATASTROPHIC STRUCTURAL FAILURE AT DUL

B-BASIS ALLOWABLE STRAIN = 3304. M.S. = .22
A-BASIS ALLOWABLE STRAIN = 2755. M.S. = .02

FOR DAMAGE TOLERANCE DESIGN REQUIREMENT NO. 2
NO CATASTROPHIC STRUCTURAL FAILURE AT MSL=1.25DLL

B-BASIS ALLOWABLE STRAIN = 4130. M.S. = .53
A-BASIS ALLOWABLE STRAIN = 3444. M.S. = .28

FOR DAMAGE TOLERANCE DESIGN REQUIREMENT NO. 3
NO INITIAL FAILURE AT DLL AND NO CATASTROPHIC
STRUCTURAL FAILURE AT MSL

B-BASIS ALLOWABLE STRAIN = 4130. M.S. = .53
A-BASIS ALLOWABLE STRAIN = 3444. M.S. = .28

FOR DAMAGE TOLERANCE DESIGN REQUIREMENT NO. 4
NO INITIAL/LOCAL FAILURE AT DLL

B-BASIS ALLOWABLE STRAIN = 3007. M.S. = .11
A-BASIS ALLOWABLE STRAIN = 2353. M.S. = -.13

RELIABILITY AT DUL: IF = .95815 FF = .99254
RELIABILITY AT MSL: IF = .99627 FF = .99957
RELIABILITY AT DLL: IF = .99958 FF = .99995

Stop - Program terminated.