

Army Research Laboratory



924-MHz Wind Profiling Radar Acceptance Tests

**By Gail T. Vaucher
Edward Creegan
Jimmy Yarbrough
Information Science and Technology Directorate
Battlefield Environment Division**

ARL-TR-1815

November 1998

**Reproduced From
Best Available Copy**

Approved for public release; distribution is unlimited.

19981217 071

NOTICES

Disclaimers

The findings in this report are not to be construed as an official Department of the Army position unless so designated by other authorized documents.

The citation of trade names and names of manufacturers in this report is not to be construed as official Government indorsement or approval of commercial products or services referenced herein.

REPORT DOCUMENTATION PAGE		Form Approved OMB No. 0704-0188	
Public reporting burden for this collection of information is estimated to average 1 hour per response, including the time for reviewing instructions, searching existing data sources, gathering and maintaining the data needed, and completing and reviewing the collection of information. Send comments regarding this burden estimate or any other aspect of this collection of information, including suggestions for reducing the burden to Washington Headquarters Services, Directorate for Information Operations and Reports, 1215 Jefferson Davis Highway, Suite 1204, Arlington, VA 22202-4302 and to the Office of Management and Budget, Paperwork Reduction Project (0704-0188), Washington, DC 20503.			
1. AGENCY USE ONLY (Leave Blank)	2. REPORT DATE November 1998	3. REPORT TYPE AND DATES COVERED Final	
4. TITLE AND SUBTITLE 924-MHz Wind Profiling Radar Acceptance Tests		5. FUNDING NUMBERS	
6. AUTHOR(S) Gail T. Vaucher, Edward Creegan, Jimmy Yarbrough			
7. PERFORMING ORGANIZATION NAME(S) AND ADDRESS(ES) U.S. Army Research Laboratory Information Science and Technology Directorate Battlefield Environment Division Attn: AMSEL-IS-EA White Sands Missile Range, NM 88002-5501		8. PERFORMING ORGANIZATION REPORT NUMBER ARL-TR-1815	
9. SPONSORING/MONITORING AGENCY NAME(S) AND ADDRESS(ES) U.S. Army Research Laboratory 2800 Powder Mill Road Adelphi, MD 20783-1145		10. SPONSORING/MONITORING AGENCY REPORT NUMBER ARL-TR-1815	
11. SUPPLEMENTARY NOTES			
12a. DISTRIBUTION/AVAILABILITY STATEMENT Approved for public release; distribution is unlimited.		12b. DISTRIBUTION CODE A	
13. ABSTRACT (Maximum 200 words) In March of 1998, the Artillery Branch of the Army Research Laboratory received a Reconstructed 924 MHz Wind Profiling Radar System. Over the subsequent months, several hardware tests were conducted to verify the successful functioning of the radar components and integrated system. In this technical publication, seven radar evaluation tests are documented. The first two radar evaluation tests, the Frequency Survey, and the Local Site and Internal Radar System Noise Tests, examine the non-operational environments for possible radar signal corruption sources. The radar signal itself is reviewed in the Radar Signal Analysis Test. Finally, the radar's components are isolated and evaluated in the 'I' and 'Q', Opposing Beams, System Noise Test: Pre-Amplifier, and System Noise Test: Distributed Amplifier Tests. Each Test explanation includes: (1) the Radar Test Purpose, (2) the Hardware/Test Setup and Materials, (3) the Test Description, and (4) the Results and Result Interpretation. Figures displaying specific hardware setup, or test results are included, as appropriate. Appended to the text are results from the initial radar verification exercise. Brief excerpts from the Radar Acceptance Test logbook are included, to enhance the reader's understanding.			
14. SUBJECT TERMS wind profiling radar, 924-MHz radar, radar, pre-amplifier, main amplifier, Frequency Site Survey		15. NUMBER OF PAGES 140	
		16. PRICE CODE	
17. SECURITY CLASSIFICATION OF THIS REPORT UNCLASSIFIED	18. SECURITY CLASSIFICATION OF THIS PAGE UNCLASSIFIED	19. SECURITY CLASSIFICATION OF ABSTRACT UNCLASSIFIED	20. LIMITATION OF ABSTRACT SAR

Preface

This report presents seven wind profiling radar tests conducted by the Artillery Branch of the U.S. Army Research Laboratory used to verify the successful functioning of the Reconstructed 924-MHz Wind Profiling Radar System. The purpose of this report is to provide a baseline reference for any future evaluation exercises.

Acknowledgements

Many thanks to Mr. John Neuschaefer, Mr. Stan Parsons, Mr. Carlton Schneider, and Dr. Bob Weber for their assistance with the testing effort. Their time, suggestions, and seasoned insights were very much appreciated.

Contents

Preface	1
Acknowledgements	3
Executive Summary	7
1. Background	9
2. Radar Basics	11
3. Frequency Survey Test	15
3.1 <i>Frequency Survey Test Purpose</i>	15
3.2 <i>Hardware Setup and Materials</i>	15
3.3 <i>Test Description</i>	15
3.4 <i>Results and Result Interpretation</i>	17
4. Local Site And Internal Radar System Noise Test	19
4.1 <i>Local Site and Internal Radar System Noise Test Purpose</i>	19
4.2 <i>Test Setup and Description</i>	19
4.3 <i>Results and Result Interpretation</i>	19
5. Radar Signal Analysis Test	21
5.1 <i>Radar Signal Analysis Test Purpose</i>	21
5.2 <i>Hardware Setup and Materials</i>	21
5.3 <i>Test Description</i>	22
5.4 <i>Results and Result Interpretation</i>	22
6. “I” and “Q” Tests	23
6.1 <i>“I” and “Q” Test Purpose</i>	23
6.2 <i>Hardware Setup and Materials</i>	24
6.3 <i>Test Description and Results</i>	24
6.4 <i>Result Interpretation</i>	24
7. Opposing Beams Test/Phase Shifter Functionality Test	25
7.1 <i>Opposing Beams Test Purpose</i>	25
7.2 <i>Test Setup and Description</i>	25
7.3 <i>Results and Result Interpretation</i>	25

8. System Noise: Radar Pre-amplifier Test	27
8.1 <i>Radar Pre-amplifier Test Purpose</i>	27
8.2 <i>Hardware Setup and Materials</i>	27
8.3 <i>Test Description</i>	29
8.4 <i>Results and Result Interpretation</i>	29
9. System Noise: Radar Distributed Amplifier Test	31
9.1 <i>Radar Distributed Amplifier Test Purpose</i>	31
9.2 <i>Hardware Setup and Materials</i>	31
9.3 <i>Test Description</i>	33
9.4 <i>Results and Result Interpretation</i>	33
10. Miscellaneous Tests And Results	35
11. Final Remarks	37
Reference	39
Acronyms and Abbreviations	41

Appendices

<i>Appendix A. Results from Interchanging Reconstructed 924-MHz Wind Profiling Radar System Components into an Operational WSMR 924-MHz Wind Profiling Radar System</i>	43
<i>Appendix B. Results from Elevating the Ground Clutter Removal Height of the Reconstructed 924-MHz Wind Profiling Radar System</i>	105
Distribution	129

Figures

1. Reconstructed mobile 924-MHz wind profiling radar	9
2. Radar basics: POP4	12
3. Frequency survey test hardware configuration.....	16
4. Results from a local site and internal radar system noise test	20
5. Radar signal analysis test hardware configuration	21
6. A sample of results from an “I” and “Q” test.....	23
7. Results from an opposing beams test	26
8. Pre-amplifier test hardware configuration.....	28
9. Main amplifier test hardware configuration	32

Executive Summary

In March of 1998, the Artillery Branch of the Army Research Laboratory received a Reconstructed 924 MHz Wind Profiling Radar System. Over the subsequent months, several hardware tests were conducted to verify the successful functioning of the radar components and integrated system. Seven radar evaluation tests are documented in this report.

The first two radar evaluation tests, the Frequency Survey, and the Local Site and Internal Radar System Noise Tests, examine the non-operational environments for possible radar signal corruption sources. The radar signal itself is reviewed in the Radar Signal Analysis Test. Finally, the radar's components are isolated and evaluated in the 'I' and 'Q', Opposing Beams, System Noise Test: Pre-Amplifier, and System Noise Test: Distributed Amplifier Tests.

Each test explanation includes: (1) the radar test purpose, (2) the hardware/test setup and materials, (3) the test description, and (4) the results and result interpretation. Figures displaying specific hardware setup or test results are included, as appropriate. Appended to the text are results from the initial radar verification exercise. To enhance the reader's understanding, brief excerpts from the Radar Acceptance Test logbook are included.

1. Background

In March of 1998, the Artillery Branch of the U.S. Army Research Laboratory (ARL) received a reconstructed 924-MHz Wind Profiling Radar System (figure 1). Over the subsequent months, several hardware tests were conducted to verify the successful functioning of the radar components and integrated system. This report is intended to be a technical reference for guiding future evaluations of radar systems and to document many of the results from the initial verification tests.



Figure 1. Reconstructed mobile 924-MHz wind profiling radar.

The explanatory structure for each radar tests consists of:

- the radar test purpose;
- the hardware test setup and materials;
- a test description; and
- the results, with an interpretation of the results.

Figures displaying the hardware setup and a sample of results (when available) are included.

2. Radar Basics

The basic data acquisition concept for the Wind Profiling Radar begins with a signal of a given frequency being transmitted into the atmosphere, scattered off targets (such as, humidity, turbulence, or solid objects) and returned to (“heard by”) the radar. The time delay between the transmission and reception is bracketed into gates and is used to determine the representative height of the signal being returned. Through various signal processing steps [such as, time averaging, fast Fourier transfer (FFT), and spectral averaging], the received data are ultimately translated into wind speed and wind direction. Further details on Radar data collection are found in *LAP-3000 Operation and Maintenance Manual for the Mobile Profilers* (see reference).

During most of the following tests, the signal processing steps were interrupted at the point where the spectral curves for each gate were displayed. The primary radar software used during these 924-MHz radar tests was the Profiler On-line Program, Version 4 (POP4). The output display consisted of two plots and various radar sampling specifications documented around the plots (figure 2). The main plot (left side) displayed the power spectral/radial velocities sampled at each gate of the individual beam (X-axis). The maximum and minimum values for the X-axis were displayed, and represent the Nyquist frequency values. Note that positive radial velocities indicate Doppler motion toward the antenna, and negative values indicate motion away from the antenna. The Y-axis showed the power spectrum for each of the individual range gates. These range gates sampled were stacked lowest to highest, and scaled to height in kilometers (km).

The second POP4 plot displayed individual moment values for each range gate. The four specific curves included: (1) return power (signal), (2) system noise, (3) signal-to-noise ratio (SNR), and (4) zero reference line. The X-axis was scaled in 10 dB intervals. Y-axis was in gate number/height (kilometer). For further details, consult the *LAP-3000 Operation and Maintenance Manual for the Mobile Profilers*.

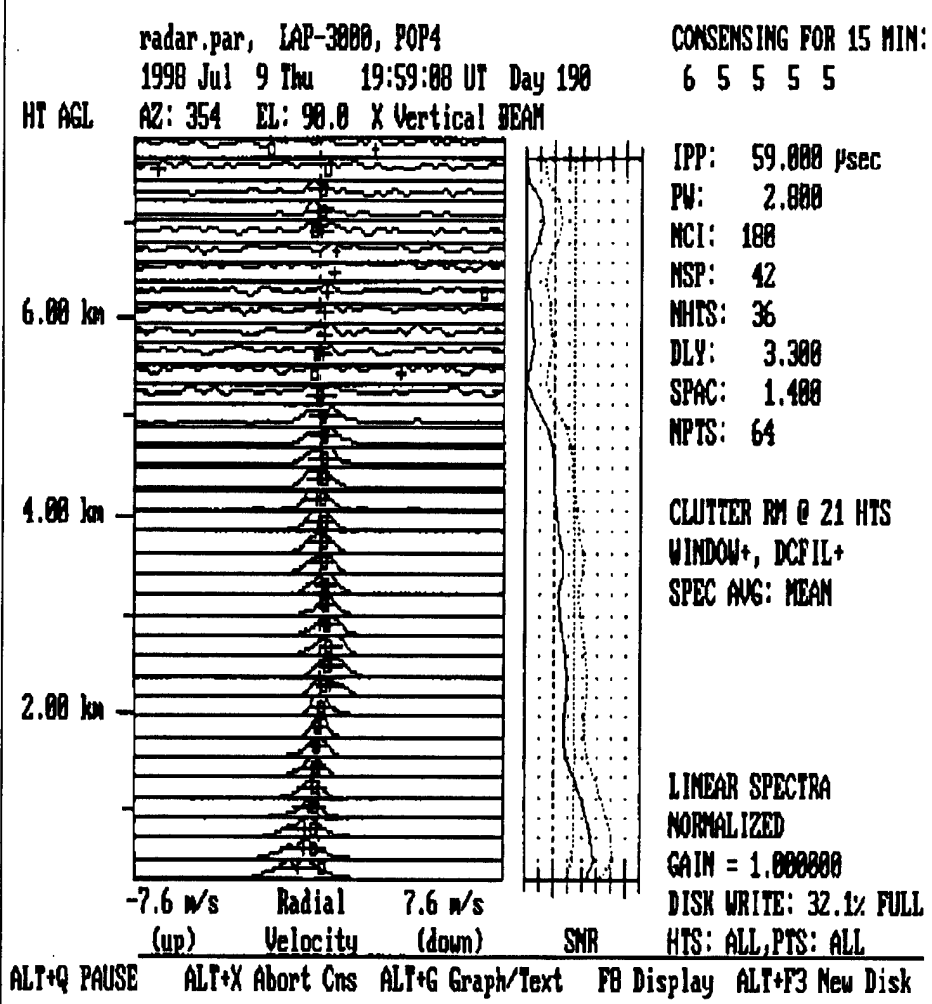

NOTE: Output Display. The left-side graph shows the power spectral/radial velocities versus height (kilometers). The right side graph displays the return power (signal), the system noise, SNR, and a zero reference line versus height (km).

Figure 2. Radar basics: POP4.

The detailed interpretation of the two plots requires a significant amount of understanding and experience with the sensor. For this technical report, however, only the most basic interpretation technique will be described:

The first step in interpreting the various POP4 profiler radar plots is to examine the system noise. Ideally, this will be a straight or near-straight vertical line approximately -10 dB. The SNR curve is examined next, noting the height at which the SNR curve dips below the -10 dB increment. Any data received when the SNR is less than or equal to -10 dB will typically generate questionable results. The user should also notice that the spectral curves for the gates reporting these conditions are significantly noisier, than those curves where the SNR is greater than -10 dB. The only exception to this characteristic is when the user has incorporated specialized advanced signal processing techniques in the radar processing software.

The expected atmospheric return will typically produce a single, non-symmetrical, power spectral peak. The center of this peak indicates the dominant radial velocity sampled for a specific gate.

For nonvertical beams, the single, nonsymmetrical peak will predominantly occur away from the center point. When a series of gates for a single beam consistently displays a symmetrical center peak (dc peak), this could indicate system noise. That is, the source of the return has no motion. Likewise, if a series of gates repeatedly displays a symmetrical peak at a single velocity, this also could indicate a system noise. It is important that the investigator remember that "the system" for this sensor includes not only the hardware, but also the environment. While investigating the cause for a series of elevated (2.5 to 3 km), symmetrical center peaks, the source was determined to be ground clutter. That is, under those particular atmospheric conditions, the radar signal was bouncing off local ground clutter, and by traversing multiple paths, the delayed time the signal took to return to the radar placed the ground clutter return at the elevated gates. With the use of advanced signal processing (second peak data processing), this phenomena can be identified and eliminated from the analysis, resulting in the gleaning of only useful atmospheric information.

One of the primary reasons for conducting the following investigation was to gain a better understanding for the observed, atypical "system noise" symptoms. While these tests are not all encompassing, they do help to explain and/or eliminate various radar phenomena.

3. Frequency Survey Test

The first test for a new site deals with the passive radio frequency (RF) signals present in the ambient atmosphere. Some specialized tools are required, and this test does presume that the user understands how to use a spectrum analyzer.

3.1 Frequency Survey Test Purpose

The quality of the 924-MHz wind profiler data is partly a function of the uniqueness of the 924-MHz return signal. When selecting a new site, a survey of the ambient signals not only quantifies the signal character in the local atmosphere, but helps the user to better optimize the beam selection. In short, the frequency survey test provides a survey (0° to 360° azimuth, 0° to 90° elevation) of the RF-noise present in the local atmosphere, which in turn, is a prerequisite for determining the wind profiler's "ideal" beam direction combination.

3.2 Hardware Setup and Materials

The tools required for this test consist of a 924-MHz wind profiler radar antenna panel (preferably an extra antenna panel that is not part of your operational radar system), a low noise amplifier (LNA) for the 924-MHz frequency, RG402 and standard BNC cables with appropriate connectors, a power supply, and a spectrum analyzer. Figure 3 displays the general configuration. A textual flow diagram is shown below.

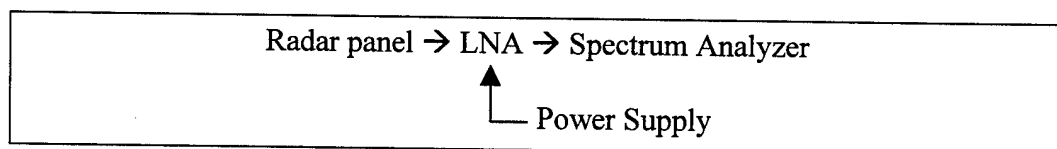

3.3 Test Description

Important: The frequency survey test is performed with the wind profiling radar system turned off. Begin this test by assembling all hardware components, except the power supply-LNA connection. Conduct an independent check of the power supply with a Fluke meter to verify a 15 V supply of power. TURN OFF the power supply before attaching it to the LNA. Turn on the spectrum analyzer, then the power supply and observe the peaks on the spectrum analyzer.

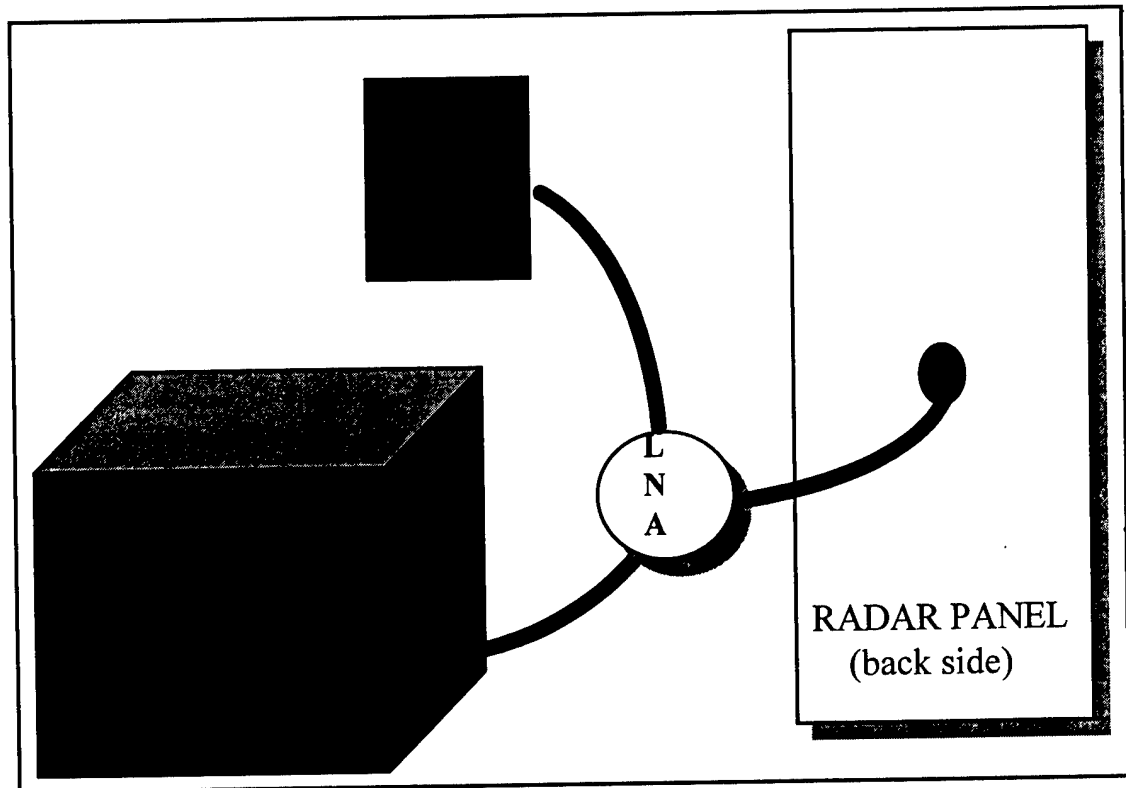

Figure 3. Frequency survey test hardware configuration.

The flow of information begins with the hand-held radar panel passively receiving signals that are amplified by the LNA, which is powered with a power supply and displayed on the spectrum analyzer. While one scientist smoothly rotates the radar panel, a second scientist observes the spectrum analyzer noting any signals close to the 924 MHz frequency of the radar and the direction the panel is facing when the 924-MHz/near-924 MHz signals are being received. If only one scientist is executing this test, a turntable can be built for the panel's rotation.

A representative atmospheric survey can be efficiently performed by rotating the hand-held radar panel in three patterns. First, the Horizontal Survey: Position the panel facing north at 0° elevation. Smoothly and slowly begin a 360° horizontal rotation toward the east, south, west and north. The second and third patterns examine the vertical dimension. Position the hand-held panel to the north at 0° elevation. While facing north, slowly and smoothly elevate the panel to 90°; turn from north to south and conclude the sweep toward the south from zenith to 0° elevation. The final survey follows the same 0-90-0° vertical sweep; however, the path starts in the east and ends in the west.

3.4 Results and Result Interpretation

Ideally, the noise floor around the target frequency of 924 MHz should be fairly quiet and free from spikes. If, however, the noise floor is elevated or ambient spikes of signal are noted near or at 924 MHz, the quadrants in which these events are noted should be avoided when selecting the radar's beam configuration.

Currently, a common source for interference of the 924 MHz signal is cellular phones. These signals are often in the 915-MHz frequency range and generally occur intermittently/randomly. If the radar is working near a populated area, the researchers should become familiar with cellular phone relay towers. Visually siting their locations would complement this survey exercise by providing an independent validation of the results.

Also noteworthy is that a site's ambient RF noise will exhibit diurnal and seasonal characteristics; that is, the direction selected as the ideal beam direction (i.e., having the lowest noise) in the evening, may not be so during daylight hours. Conducting the frequency survey test several times in a day or during various seasons is recommended.

4. Local Site and Internal Radar System Noise Test

The local site and internal radar hardware components are potential sources for noise. Depending on the power source, most U.S. sites will show the equivalent of a 60 Hz noise. This test requires an operational radar system, a 50-ohm terminator, and the ability to display stacked power spectral curves.

4.1 Local Site and Internal Radar System Noise Test Purpose

The local site and internal radar system noise test display the cumulative local area (local light sources, etc.) and internal radar system noise in radial velocity measurements. Humidity, grounding, and other electrical sources can affect the results.

4.2 Test Setup and Description

The test setup begins with an operational Wind Profiling Radar System. Disconnect the receiver-in cable on the back of the receiver/modulator unit. (NOTE: The transmit cable need not be disconnected.) Connect the 50-ohm terminator to the receiver-in BNC connector. Observe the stacked power spectral plots.

4.3 Results and Result Interpretation

The expected results for U.S. sites are spectral peaks in all range gates at the equivalent 60 Hz radial velocity magnitude. Typically, the 924-MHz radar places the peak at a radial velocity of approximately ± 9.7 m/s. If peaks are not present, increase the maximum radial velocity scale. The operator may also need to increase the number of coherent iterations (NCI) to greater than 350. NOTE: the SNR should be very low (i.e., -20 dB). See figure 4.

If the 60 Hz ($\sim \pm 9.7$ m/s) peaks are detected in all range gates, this indicates that the receiver is functioning correctly. If the 60 Hz peaks are entirely absent, this doesn't necessarily indicate failure. However, additional testing is recommended. If other signal patterns of the same amplitude are also present in the power spectra, ambient signals are present and need to be identified. Additional receiver/modulator tests should be conducted.

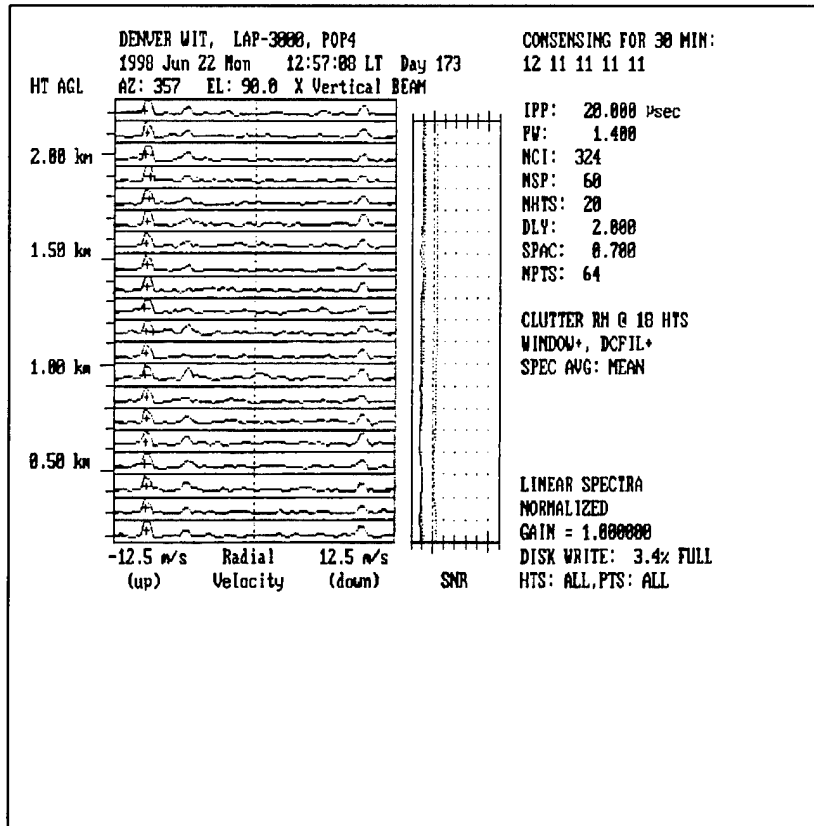

Figure 4. Results from a local site and internal radar system noise test.

5. Radar Signal Analysis Test

The radar signal analysis (RSA) test displays the real-time, transmitted and received radar signals, allowing the researcher to identify and observe any spurious signal from nonatmospheric sources. Some specialized tools are required, and this test does presume that the user understands how to use an oscilloscope.

5.1 Radar Signal Analysis Test Purpose

The purpose of the RSA test is to check for systematic and unexplained noise in the transmitted and received radar signals. An additional benefit is the opportunity to validate the interpulse period (IPP) length. When the radar's power spectral curves appear questionable, this test is one of the initial tests to be performed.

5.2 Hardware Setup and Materials

The tools required for this test consist of the standard operational wind profiling radar setup, an oscilloscope (100-MHz or better) and three oscilloscope cables. See figure 5 for hardware setup. A textual diagram follows.

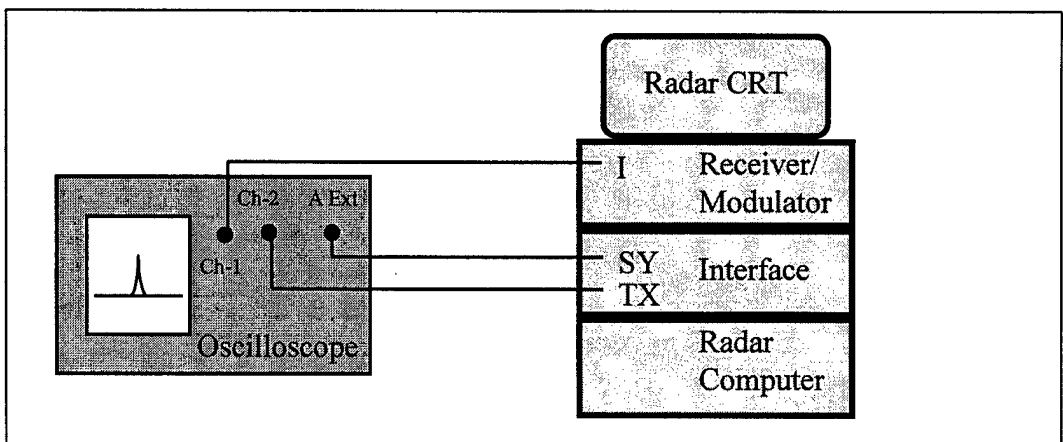
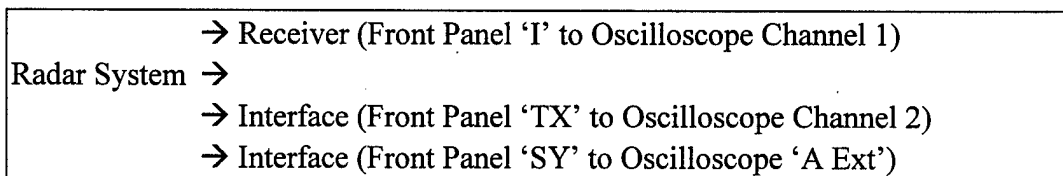

Figure 5. Radar signal analysis test hardware configuration.

5.3 Test Description

Beginning with an operational 924-MHz radar configuration, disconnect the transmit cable on the back of the receiver/modulator unit. From the interface front panel, connect "SY" (sync) to the oscilloscope "A Ext" (external). This action will coordinate the internal timing of the two units. Next, connect the interface front panel "TX" (transmit) to oscilloscope Channel 2. From the receiver front panel, connect "I" (in-phasing) to the oscilloscope Channel 1. (NOTE: the quadrature, Q is left open.) Adjust the oscilloscope scales (i.e., ch 1 = 0.2 V/div; ch 2 = 2 V/div; A and B = 5 μ s;) and observe the oscilloscope values.

5.4 Results and Result Interpretation

The signal displayed on the oscilloscope should show a major pulse followed by a series of successive, much smaller oscillations. The large pulse is the outgoing signal, the minor pulses are the return signals being heard by the radar system. These smaller amplitude pulses are complex, and vary rapidly. Thus, they will appear somewhat fuzzy, especially as you increase the resolution of the oscilloscope scaling. The display's x-axis is Time and each Time interval between pulses should agree with the IPP in your configuration file.

When the signal reflects from transient hard objects (birds, planes, etc.), the displayed signal will suddenly expand significantly. When the sampling area is cleared of the object, the display will return to the original periodic pattern. For best RSA test results, the recommendation is that only one beam at a time be selected and observed.

6. "I" and "Q" Tests

Removing the Doppler element of the radar is also an informative exercise to test. For the wind profiling radar user, this test requires no external equipment.

6.1 "I" and "Q" Test Purpose

The purpose of the "I" and "Q" tests are to check the functioning of the signal's in-phase and quadrature, respectively. This test presumes that the user has access to a stacked power spectral display plot (figure 6).

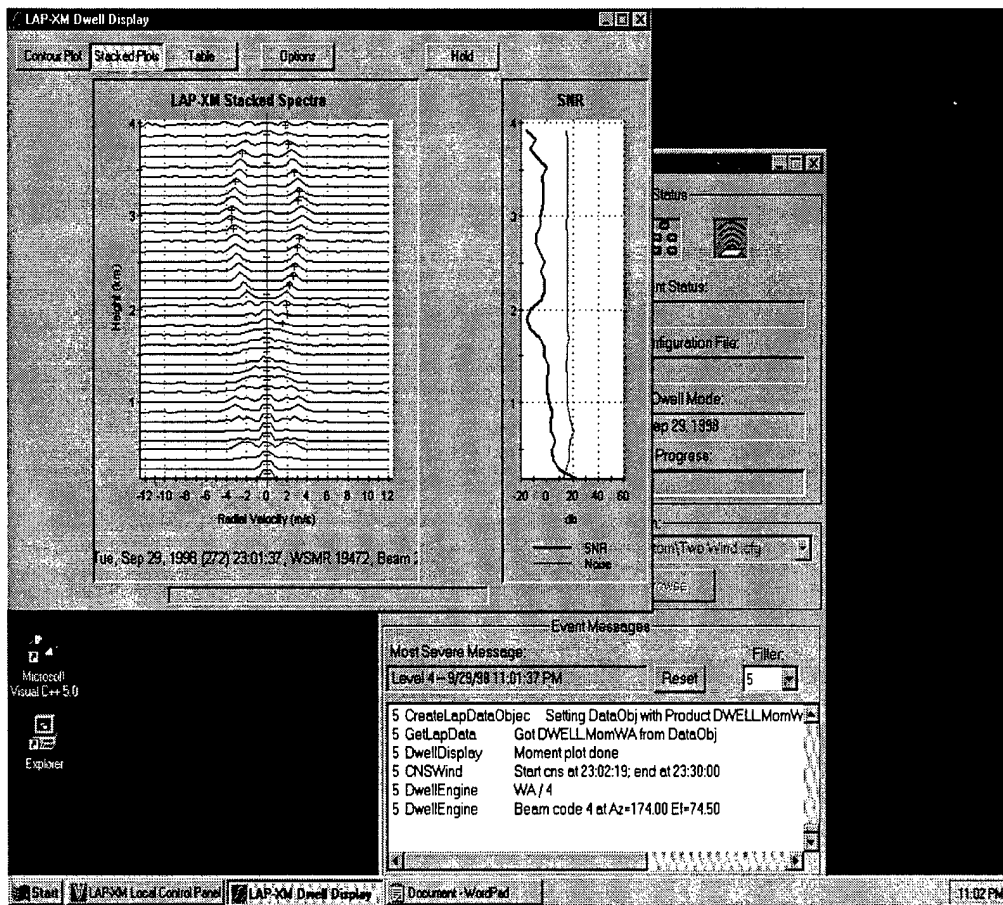

Figure 6. A sample of results from an "I" and "Q" test.

6.2 Hardware Setup and Materials

The equipment required for this test is the standard operational Wind Profiling Radar System, as well as, software that will display stacked power spectral curves.

6.3 Test Description and Results

Begin this test by operating the radar in the normal wind-profiling mode. Disconnect the "I" output cable on the back panel of the receiver/modulator unit. Allow the radar to take three more cycles of samples. Then, observe the pattern of the stacked power spectral display. The curves should be symmetrical around the center point [direct current (dc) peak].

Reconnect the "I" output cable and disconnect the "Q" Output cable. Allow the radar to cycle through three sampling sets, then observe the stacked power spectral display pattern. As before, the curves should be symmetrical around the center point (figure 6).

6.4 Result Interpretation

The expected symmetrical pattern around dc results from the absence of Doppler information in the displayed data set. If any other pattern is observed, depot level maintenance is required. That is, your radar manufacturer may have to replace various radar components to resolve this error.

7. Opposing Beams Test/Phase Shifter Functionality Test

The opposing beams test requires no specialty hardware. This diagnostic tool does, however, require data analysis software that is able to display power spectra curves vertically stacked and/or the ability to overlay user-selected stacked power spectral plots.

7.1 Opposing Beams Test Purpose

The primary purpose of the opposing beams test is to provide the initial check whether the phase shifters are functioning correctly. NOTE: the phase shifters are responsible for the steering of the beams.

7.2 Test Setup and Description

The opposing beams test requires an operational wind profiling radar, with software that allows the user to select the beam configuration. As mentioned above, having a near real-time visual display of the power spectra curves vertically stacked and/or the ability to overlay user-selected spectral plots are highly recommended. POP4 has both the near real-time spectral displays and the ability to overlay spectral graphs.

The test begins with an operational wind profiling radar setup. Before initiating the radar transmission, enter the radar's parameter setup screen. Select the beam order as north then south, east then west, x-vertical then y-vertical. This 6-beam sequence can also be done in pairs of two such as, just north and south, just east and west, etc. Once the beam order is established, save the parameter setup and begin data collection. Observe the shape of the longwave curve formed by the power spectral maximums from gates 1 to n (50). Compare by overlaying each graph of the 2-beam set: north and south, east and west, x- and y-vertical.

7.3 Results and Result Interpretation

Ideally, the north beam spectral plot should mirror (around the 0 m/s radial velocity) the south beam spectral plot. Likewise, the east and west plots should display mirror images around the zero Doppler point. Such results imply that the phase shifters are functioning correctly. The best results occur when winds are steady, from a single direction (figure 7).

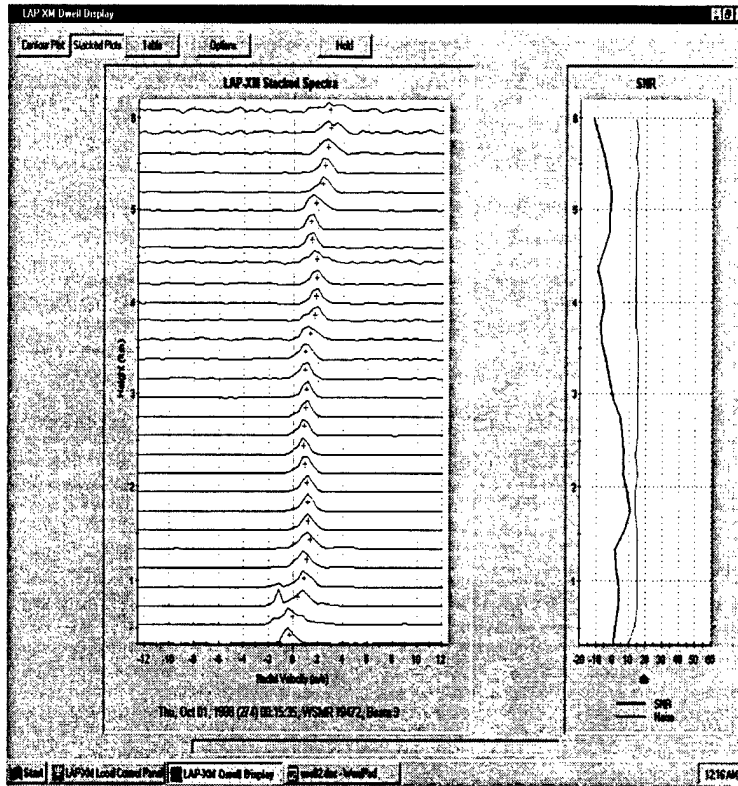

(a) West Beam

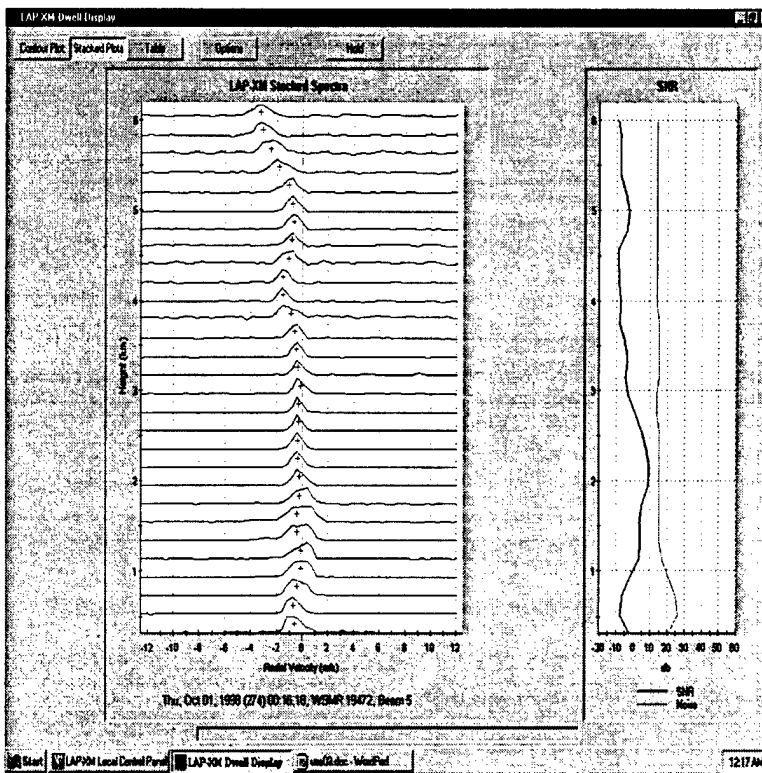

(b) East Beam

Figure 7. Results from an opposing beams test.

8. System Noise: Radar Pre-amplifier Test

System noise can originate from any component in the Wind Profiling radar System. As such, the various subsystems can be isolated and tested for noise. This test focuses on the pre-amplifier unit. Some specialized tools are required, and this test does presume that the user understands how to operate an oscilloscope.

8.1 Radar Pre-amplifier Test Purpose

The purpose of the pre-amplifier test is to check for noise in the pre-amplifier component of the wind profiling radar. This test is performed when systematic errors are evident in the power spectra curves displayed by the radar controlling software. The results will help identify or eliminate the pre-amplifier as the source of the radar's systematic errors.

8.2 Hardware Setup and Materials

Tools required consist of an operational 924-MHz Wind Profiling Radar System, a directional coupler, a crystal detector, a 50-ohm, 5-kW load, and an 100-MHz (or better) oscilloscope.

To construct this test, begin with the normal operational wind profiling radar setup. The main feed-line, J1, on the pre-amplifier unit (under antenna on trailer) is diverted into a directional coupler, which is split into two outputs. The directional coupler's X-Y switch goes to the 50-ohm 5-kW load; the right angle branch with the -30 dB drop, goes into the crystal detector, which feeds the oscilloscope. Figure 8 pictorially displays the setup. A word flow chart follows:

```
Computer/Receiver/Interface → Pre-Amp → J1 → Directional Coupler → Load.
                                     ↳ Crystal Detector → Oscilloscope.
```

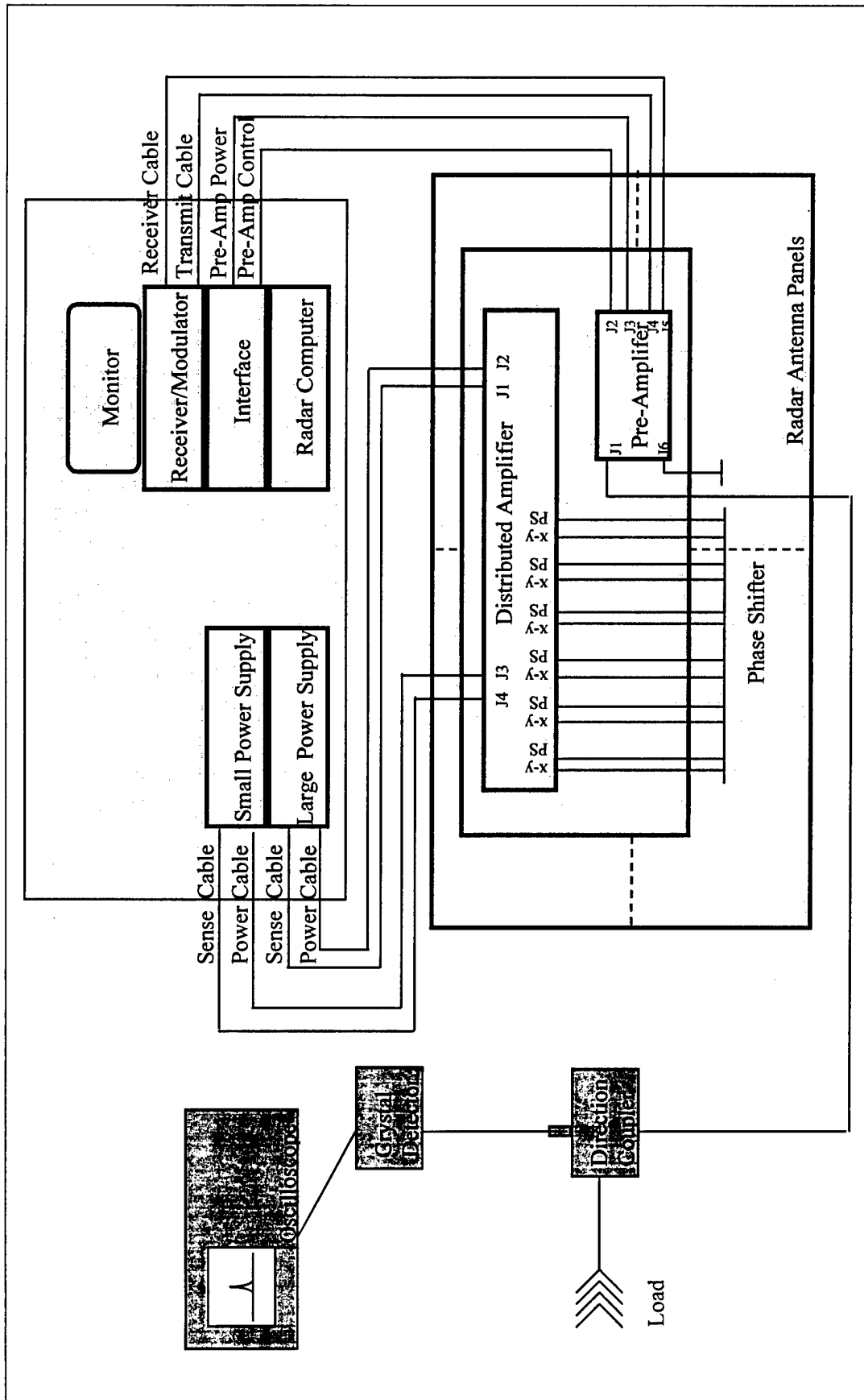



Figure 8. Pre-amplifier test hardware configuration.

8.3 Test Description

This test begins by setting the 924-MHz radar system into a mode that will continuously transmit on a single, nonvertical beam. The pre-amplifier test is conducted at the junction of the pre-amplifier unit and the phase shifter, which is prior to the signal being manipulated by the distributed amplifier (six distributed amplifiers). The pre-amplifier J1 connection is removed from the radar antenna panel (phase shifter) and reconnected to a directional coupler. This removes the distributed amplifier subassembly from the system and eliminates it as a source of noise for this test. (NOTE: Though the antenna and any external signal are also not included in this test, all other connections/cables remain in their operational configuration.) There are two exits to the directional coupler. One, the X-Y switch, passes most of the signal straight through and is connected to a 50-ohm, 5 kW load. The second, a right-angled connection, has a -30 dB drop and is connected to the crystal detector, which in turn, connects to the oscilloscope. The researcher observes the oscilloscope signal, recording the values for comparison with the known values for the radar system. These known values are available from the manufacturer.

8.4 Results and Result Interpretation

Acceptable oscilloscope values for this 924-MHz Wind Profiling Radar System should read 172 mV (+/-35 mV). Such results indicate that the pre-amplifier performance is normal. If the voltage is outside (high or low) of this range or fluctuates during the transmission (beam on) period, then the pre-amplifier should be considered unreliable and replaced with another equivalent unit. A second pre-amplifier test with the "equivalent unit" should be conducted to determine if the problem still exists. If the problem is no longer present, then the originally tested pre-amplifier unit should be repaired. If the problem still exists, the original pre-amplifier unit should still be considered unreliable and should be serviced; further testing is recommended (see system noise test: distributed amplifier test).

9. System Noise: Radar Distributed Amplifier Test

A second system noise test focuses on the distributed amplifier. Some specialized tools are required, and this test does presume that the user understands how to use an oscilloscope.

9.1 Radar Distributed Amplifier Test Purpose

The purpose of the distributed amplifier test is to check for noise in the distributed amplifier. This test is done when systematic errors are evident in the spectral display and the pre-amplifier test is inconclusive. The results will help identify and/or eliminate the six RF amplifiers in the distributed amplifier as the source of the radar's systematic errors.

9.2 Hardware Setup and Materials

Tools required for this test consist of the radar computer, interface, receiver/modulator, power supplies, distributed amplifier, pre-amplifier, radar antenna, directional coupler, crystal detector, load, and 100-MHz (or better) oscilloscope.

The setup starts with a powered-off, normal operational wind profiling radar. One of the six X-Y relay inputs (not phase shifter output) on the distributed amplifier is diverted to a directional coupler. The directional coupler splits into two outputs: the X-Y switch goes to a load; the right angle branch with the -30 dBm drop goes to a crystal detector, which displays the signal on the oscilloscope. Figure 9 shows the hardware setup pictorially. A flow chart using words follows.

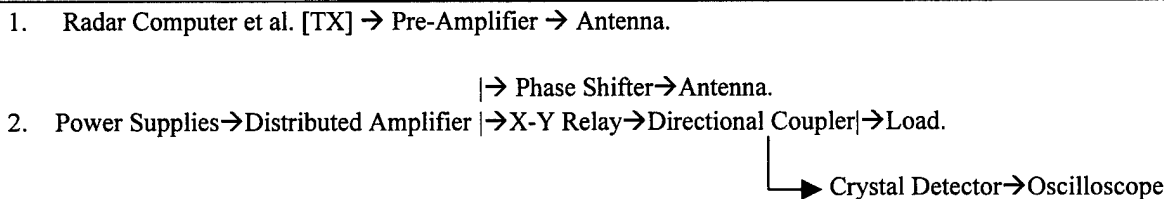

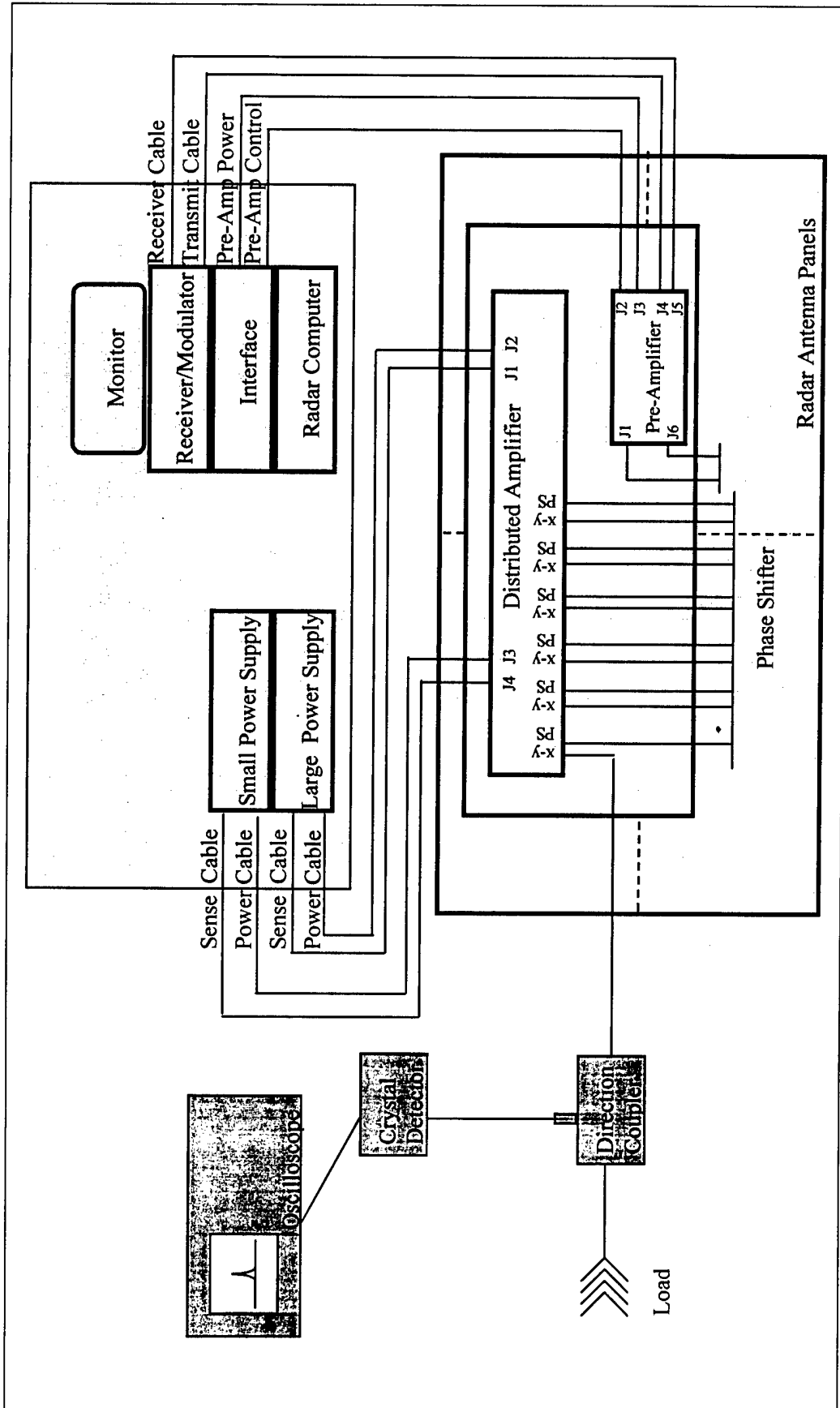

Figure 9. Main amplifier test hardware configuration.

9.3 Test Description

Begin the test by programming the 924-MHz wind profiling radar to transmit one nonvertical beam continuously. The unaltered flow of connections starts with the radar computer, progresses through the interface unit, receiver/modulator unit, then to the pre-amplifier, phase shifter, distributed amplifier, and radar antenna panel. The altered path involves selecting a single X-Y relay input from the distributed amplifier and diverting the antenna panel connection to a directional coupler. (NOTE: The phase shifter output associated with this X-Y relay input remains connected to the radar antenna panels.) There are two exits to the directional coupler. The directional coupler's XY switch connects to a load, with the right angled -30 dBm drop connected to a crystal detector, which, in turn, connects to the oscilloscope. The researcher observes the values of the oscilloscope and compares them with the known values for the radar system. Each of the six X-Y relay input amplifier nodes in the distributed amplifier need to be checked individually.

Checking the six RF amplifiers in the distributed amplifier includes the effects of all other components of the radar system, except the antenna itself. Each RF amplifier is tested individually, although if equipment is available, all amplifiers can be connected to oscilloscope displays at the same time and tested simultaneously.

9.4 Results and Result Interpretation

Acceptable oscilloscope amplitude values should read about 168 to 178 mV for each of the six amplifier nodes in the distributed amplifier. Ideally, all amplifier nodes should be within +/-35 mV of 168 mV. If the voltage is outside (low or high) of this range, or fluctuates during the transmit (beam on) period, then the RF amplifier in question should be considered unreliable and replaced with another equivalent unit to see if the problem is resolved. Replacing the entire distributed amplifier can be attempted if several RF amplifiers are behaving poorly, and an equivalent unit is available.

10. Miscellaneous Tests And Results

During the acceptance testing of the reconstructed 924 MHz wind profiling radar, the receiver/modulator unit and the interface unit of the "reconstructed radar" were brought to an accepted and operational White Sands Missile Range (WSMR) 924-MHz Wind Profiling Radar System. Results from inserting the individual components into the Operational-924 MHz radar system are displayed in appendix A.

After representatives from the National Oceanic and Atmospheric Administration (NOAA), Radian, and ARL reviewed the initial hardcopy results, a subsequent series of tests were conducted. This second major evaluation exercise used only the reconstructed 924-MHz Wind Profiling Radar System. As before, the POP4 software was used to run the system. Changes were made to the maximum height and the ground clutter reduction height. An executive test summary and the hardcopy results, with a brief description of the various test parameters written onto each hardcopy, are included in appendix B.

11. Final Remarks

The preceding tests are samples of the more informative tests conducted during the 924-MHz Reconstructed Wind Profiling Radar Acceptance Exercise. The primary focus of these tests was on the hardware. For a more complete review of an integrated Wind Profiling Radar System, the software (specifically the data processing) needs to be addressed. This software component is one of the most critical in generating valuable atmospheric information for the user. At the time of this writing, NOAA was in the process of congealing their numerous years of wind profiler experience into automated advanced signal processing algorithms. We look forward to their automated analysis insights.

Reference

The Lap-3000 Operation and Maintenance Manual for the Mobile Profilers, Radian International LLC Electronics Division, Doc Control No. 80018205, Rev B, 1996 August.

Acronyms and Abbreviations

ARL	U.S. Army Research Laboratory
dc	direct current
FFT	Fast Fourier Transfer
IPP	interpulse period
LNA	low noise amplifier
NCI	number of coherent integrations
NOAA	National Oceanic and Atmospheric Administration
POP4	Profiler On-line Program, Version 4
'Q'	quadrature
RF	radio frequency
RSA	radar signal analysis
SNR	signal-to-noise ratio
WSMR	White Sands Missile Range

Appendix A

Results from Interchanging Reconstructed 924-MHz Wind Profiling Radar System Components into an Operational WSMR 924-MHz Wind Profiling Radar System

1. PURPOSE: To understand

- (1) the source of the apparent system noise in ARL 924-MHz Wind Profiling Radar System;
 - (2) determine if the ARL radar switches are needing inspection.
- Both of the above concerns were initially described in my May 27 email to Carlton Schneider.

2. WHAT FOLLOWS:

- (1) Useful logbook entries from the initial post May 27 testing.
Location: ARL Radar Site, WSMR, NM
Software: LAP-XM 1.5
- (2) Copy of Denver Wit Site Test Logbook and representative output plots (1-56).
Location: Denver WIT Site, WSMR, NM
Software: POP4
NOTE: Plot numbers referenced in logbook are correlated with numbers on upper right corner of plots.

3. POC for RADAR TESTS:

ARL: Creegan (Engineer), Vaucher (Research Meteorologist), Yarbrough (Electronics Technician)
WSMR: Parsons (Electronics Technician)

4. TESTS DONE:

- (1) Mirror Test - test opposite off-axis beams (N-S; E-W).
- (2) '60 Hz' Noise Tests - Isolated ARL Receiver, Interface Unit, Pre-Amplifier.
 - (a) Place 50 ohm terminator on Receiver-in.
 - (b) Place 50 ohm terminator on Pre-Amp (just prior to phase shifter/antenna)

5. METHOD:

- (1) Bring WSMR Radian Radar Receiver to ARL-Radian Radar system - See 'What Follows #1'
 - (2) Bring ARL Radian Radar Receiver, Interface Unit, Pre-Amplifier to WSMR Radian Radar - See 'What follows #2'.
- NOTE: Both ARL and WSMR radars are 924-MHz Radian Radars.

6. OBSERVATIONS from TESTS DONE:

- (1) ARL site tests - Using LAP-XM (ARL system), radar return from rain was greater than the dc peak.
- (2) ARL site tests - Using LAP-XM (ARL system), dc peak (center peak) was present
 - (a) with ARL Receiver;
 - (b) with WSMR Receiver.
- (3) DENVER WIT site Tests - Using POP4 (WSMR system):
 - (a) WSMR system functioned as expected.
 - (b) Mirror Tests: Winds were light; however, when the ARL-Receiver rather than the ARL-Interface Unit was used in the WSMR Radian System, the results implied that both units were functioning acceptably.
 - (c) 60 Hz Test - 50 Ohm Terminator on ARL-Receiver.
 - (1) Gates 4-20 appeared as expected, with peaks around +/-9.7 m/s, and no center peak.
 - (2) Gates 1-3 had a migrating peak that began in the positive half and wrapped around to the negative, etc.
 - (d) 60 Hz Test - 50 Ohm Terminator on Pre-Amp

- (d) 60 Hz Test - 50 Ohm Terminator on Pre-Amp
- (1) WSMR final Amp generated expected 20 gates of noise.
 - (2) ARL Pre-Amp displayed a center peak, then a $\sim+9$ m/s peak.
 - (3) ARL Pre-Amp and ARL Receiver setup displayed 2 symmetrical ($\sim\pm 10$ m/s) peaks in gates 1-20.
Gates 1-3 included a secondary migrating peak. This migration stayed primarily in the negative half of the m/s scale.

USEFUL LOGBOOK ENTRIES FROM THE INITIAL POST, MAY 27 TESTING.

Location: ARL Radar Site, WSMR, NM
Software: LAP-XM 1.5

- 98 June 10 - 1720 z: Scattered showers, radar glossy with rain/moisture coating.
Notch no longer max peak in 80% of gates;
sometimes the remaining 20% is near sfc, sometimes near top.
- 98 June 15 - 1716z: ARL Receiver/Modulator in ARL system. (LAP-XM) – Test
Control/baseline.
Notch still in place, gates 1-50.
- 98 June 15 - 1736z: WSMR Receiver/Modulator in ARL system. (LAP-XM)
Notch still in place. Stacked plot is symmetrical much of time.
- 98 June 15 - 1751z: WSMR Receiver/Modulator in ARL system. (LAP-XM) - Notch filter on.
Notch still present. Intermittent noise mainly flatlines.

DENVER WIT, LAP-3000, POP4
 1998 Jun 19 Fri 11:15:33 LT Day 170
 AZ: 357 EL: 90.0 X Vertical BEAM

①
 CONSENSING FOR 30 MIN:
 9 8 8

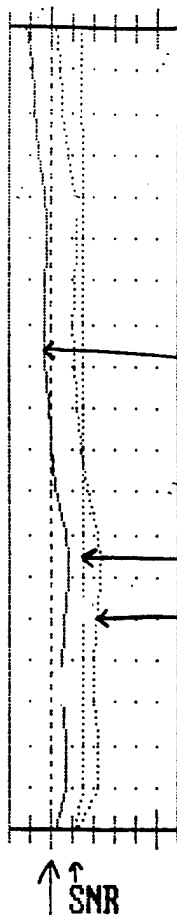
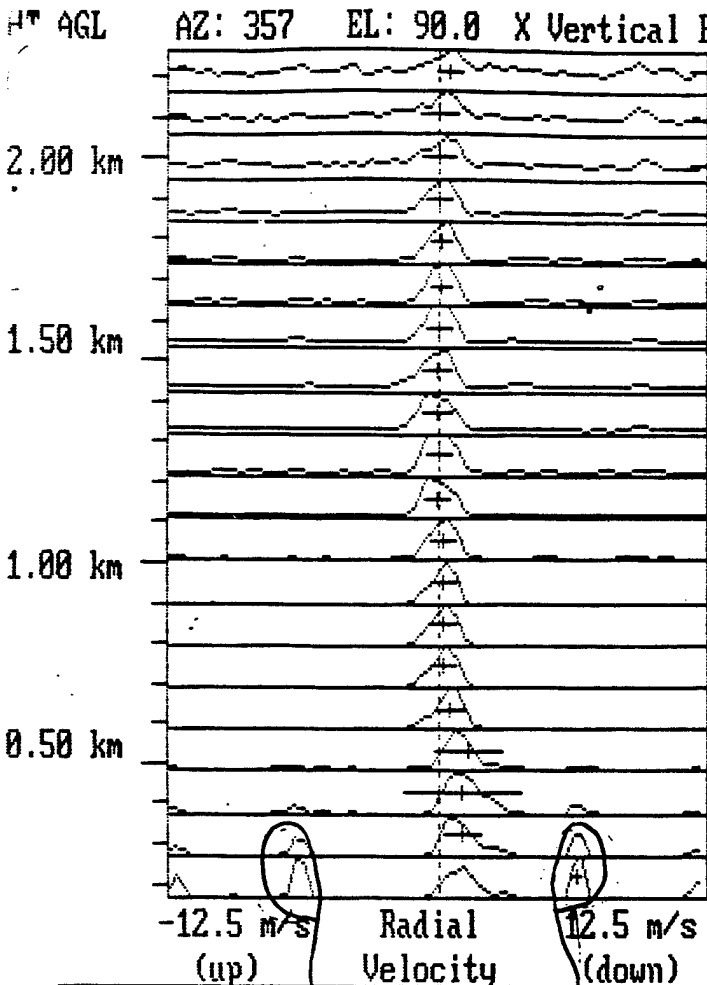

IPP: 20.000 μ sec
 PW: 1.400
 NCI: 324
 NSP: 60
 NHTS: 20
 DLY: 2.000
 SPAC: 0.700
 NPTS: 64

yellow: SNR
 CLUTTER RM @ 18 HTS
 WINDOW+, DCFIL+
 SPEC AVG: MEAN
 Purple: System Noise Level set @ 10
 Red: Rtn Power (10-20dB higher than SNR)

LINEAR SPECTRA
 NORMALIZED
 GAIN = 1.000000
 DISK WRITE: 3.4% FULL
 HTS: ALL, PTS: ALL

ground clutter

10 dB increments

[WSMR system - no changes]

DENVER WIT, LAP-3000, POP4
1998 Jun 19 Fri 11:19:18 LT Day 170
AZ: 357 EL: 66.4 North BEAM

CONSENSING FOR 30 MIN:
11 11 18

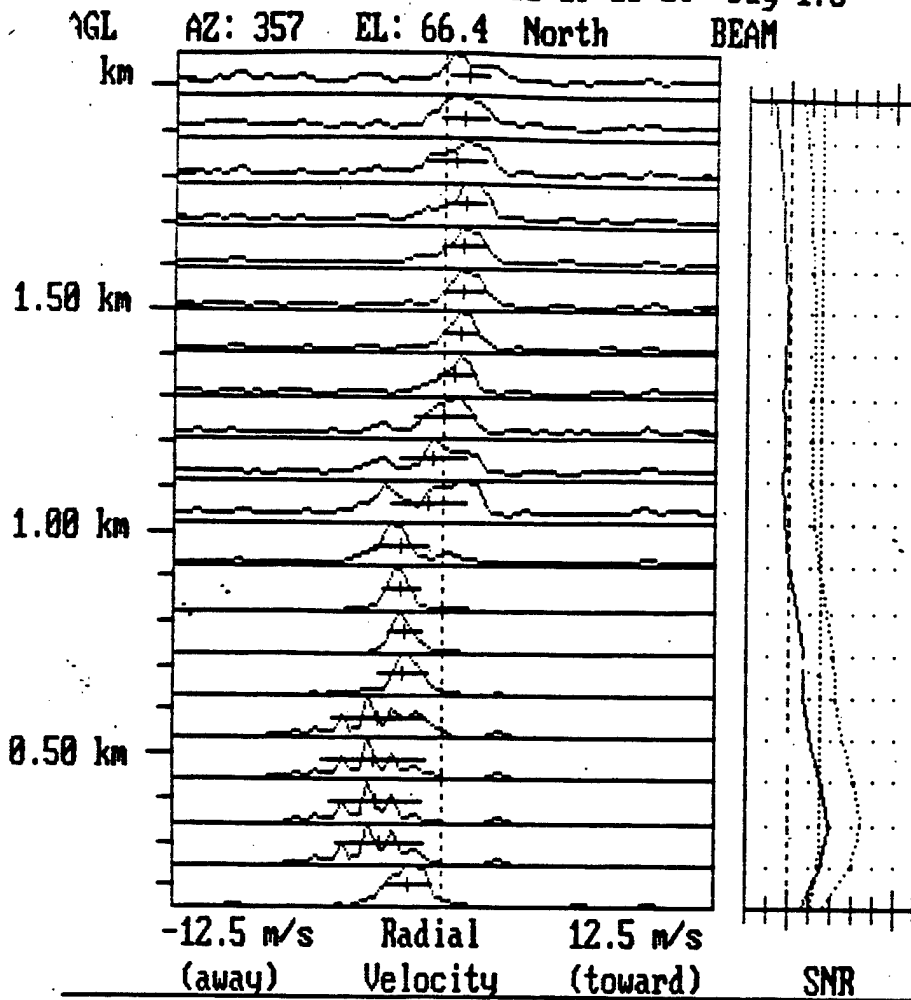

IPP: 20.000 μ sec
 PW: 1.400
 NCI: 324
 NSP: 60
 NHTS: 20
 DLY: 2.000
 SPAC: 0.700
 NPTS: 64

CLUTTER RM @ 20 HTS
 WINDOW+, DCFIL+
 SPEC AVG: MEAN

LINEAR SPECTRA
 NORMALIZED
 GAIN = 1.000000
 DISK WRITE: 3.4% FULL
 HTS: ALL, PTS: ALL

[0 - 1 km] < 0 m/s
 [1 - 2 km] > 0 m/s

DENVER WIT, LAP-3000, POP4
1998 Jun 19 Fri 11:37:18 LT Day 170
AZ: 177 EL: 66.4 South BEAM

CONSENSING FOR 30 MIN:
1 1 1 1 0

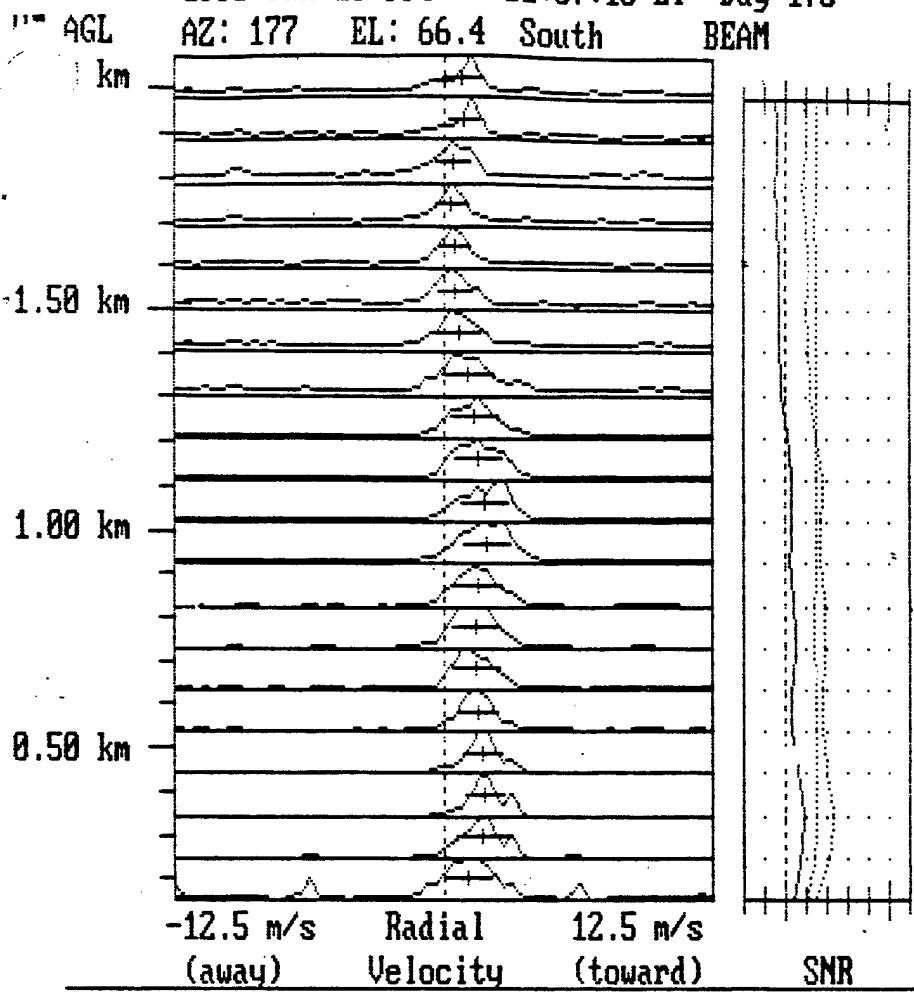

IPP: 20.000 μ sec
PW: 1.400
NCI: 324
NSP: 60
NHTS: 20
DLY: 2.000
SPAC: 0.700
NPTS: 64

CLUTTER RM @ 20 HTS
WINDOW+, DCFIL+
SPEC AVG: MEAN

LINEAR SPECTRA
NORMALIZED
GAIN = 1.000000
DISK WRITE: 3.4% FULL
HTS: ALL,PTS: ALL

[WSMR System - no changes]

[0-2km] > 0 m/s

DENVER WIT, LAP-3000, POP4
1998 Jun 19 Fri 11:26:40 LT Day 170
HT AGL AZ: 267 EL: 66.4 West BEAM

CONSENSING FOR 30 MIN:
15 15 15

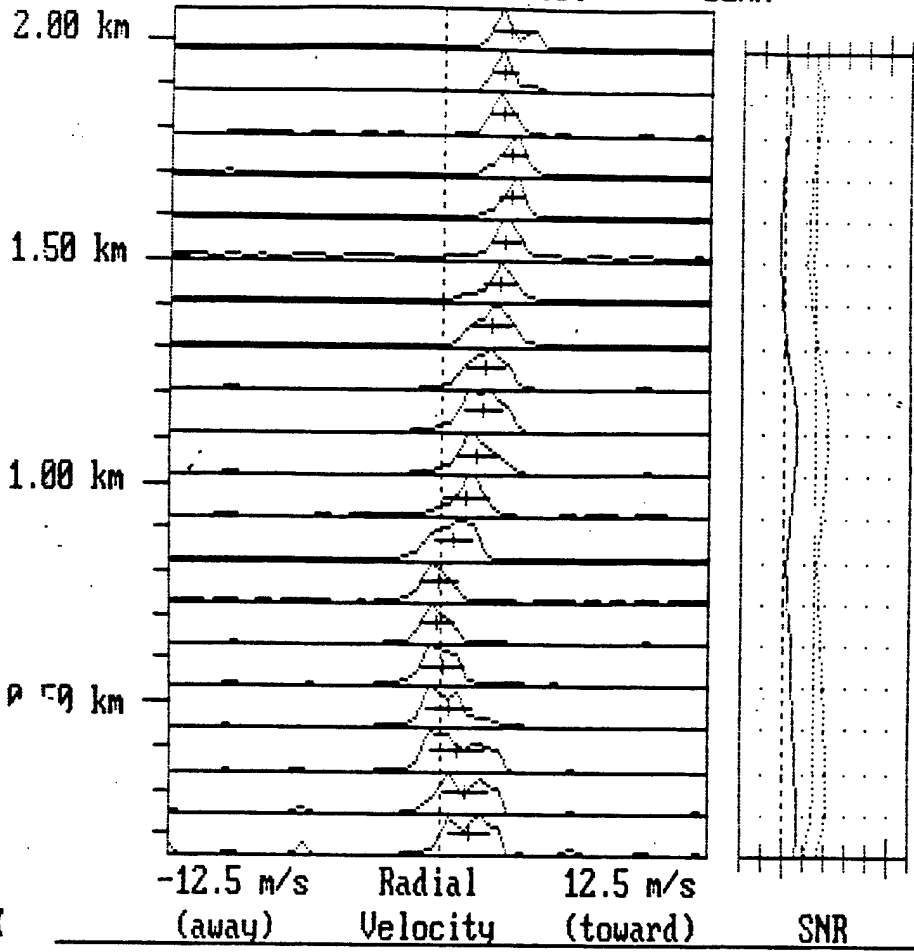

IPP: 20.000 µsec
PW: 1.400
NCI: 324
NSP: 60
NHTS: 20
DLY: 2.000
SPAC: 0.700
NPTS: 64

CLUTTER RM @ 20 HTS
WINDOW+, DCFIL+
SPEC AVG: MEAN

LINEAR SPECTRA
NORMALIZED
GAIN = 1.000000
DISK WRITE: 3.4% FULL
HTS: ALL, PTS: ALL

[WSPR System - No changes]

[0.8 km - 2 km] > 0 m/s

OK

DENVER WIT, LAP-3000, POP4
1998 Jun 19 Fri 11:43:04 LT Day 170
AZ: 87 EL: 66.4 East BEAM

CONSENSING FOR 30 MIN:
3 3 3 3 3

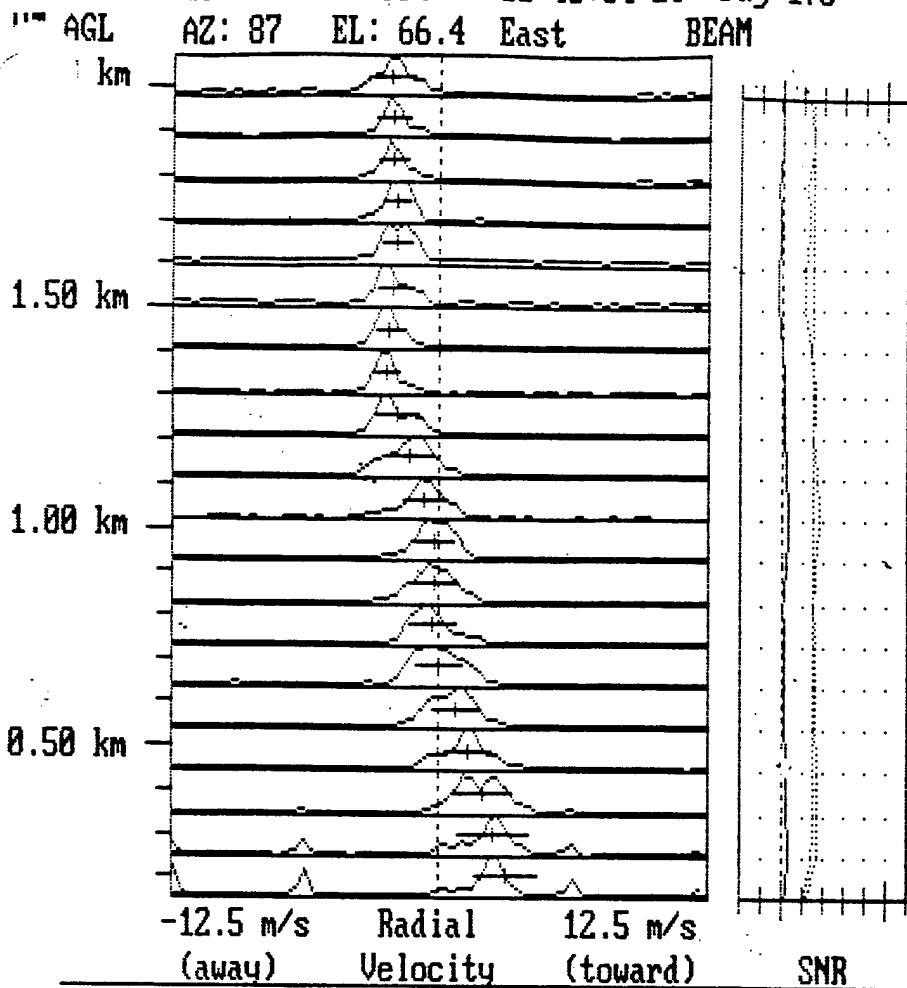

IPP: 20.000 μ sec
 PW: 1.400
 NCI: 324
 NSP: 60
 NHTS: 20
 DLY: 2.000
 SPAC: 0.700
 NPTS: 64

CLUTTER RM @ 20 HTS
 WINDOW+, DCFIL+
 SPEC AVG: MEAN

LINEAR SPECTRA
 NORMALIZED
 GAIN = 1.000000
 DISK WRITE: 3.4% FULL
 HTS: ALL, PTS: ALL

[WSMR system - No change]

[1-2 km] < 0 m/s

6

DENVER WIT, LAP-3000, POP4
1998 Jun 19 Fri 11:45:53 LT Day 170
AZ: 87 EL: 66.4 East BEAM

CONSENSING FOR 30 MIN:
4 4 4 4 4

HT AGL

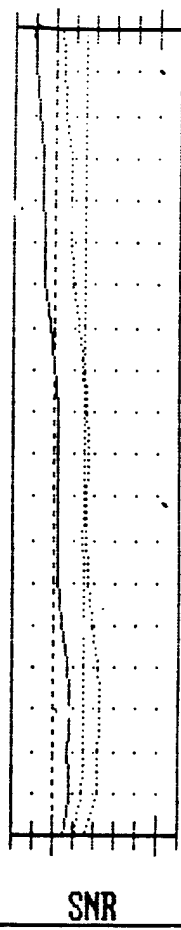
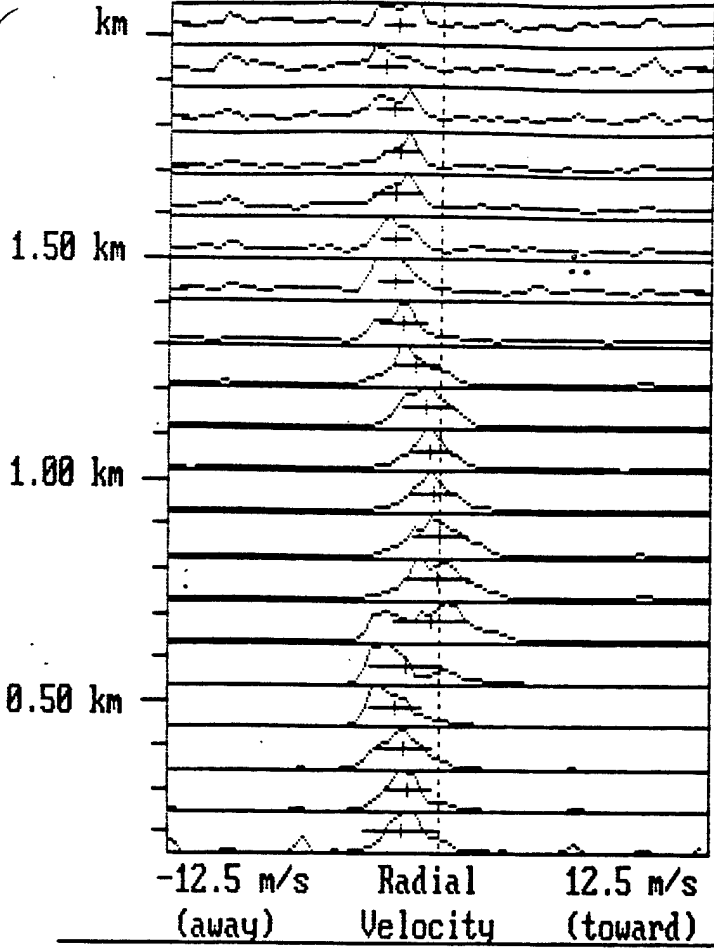

IPP: 20.000 μ sec
PW: 1.400
NCI: 324
NSP: 60
NHTS: 20
DLY: 2.000
SPAC: 0.700
NPTS: 64

CLUTTER RM @ 20 HTS
WINDOW+, DCFIL+
SPEC AVG: MEAN

LINEAR SPECTRA
NORMALIZED
GAIN = 1.000000
DISK WRITE: 3.4% FULL
HTS: ALL, PTS: ALL

[WSMR system - no changes]

[1.3 - 2 km] $< \emptyset$ m/s

DENVER WIT, LAP-3000, POP4
1998 Jun 19 Fri 11:50:09 LT Day 170
AZ: 267 EL: 66.4 West BEAM

CONSENSING FOR 30 MIN:
6 6 6 5 5

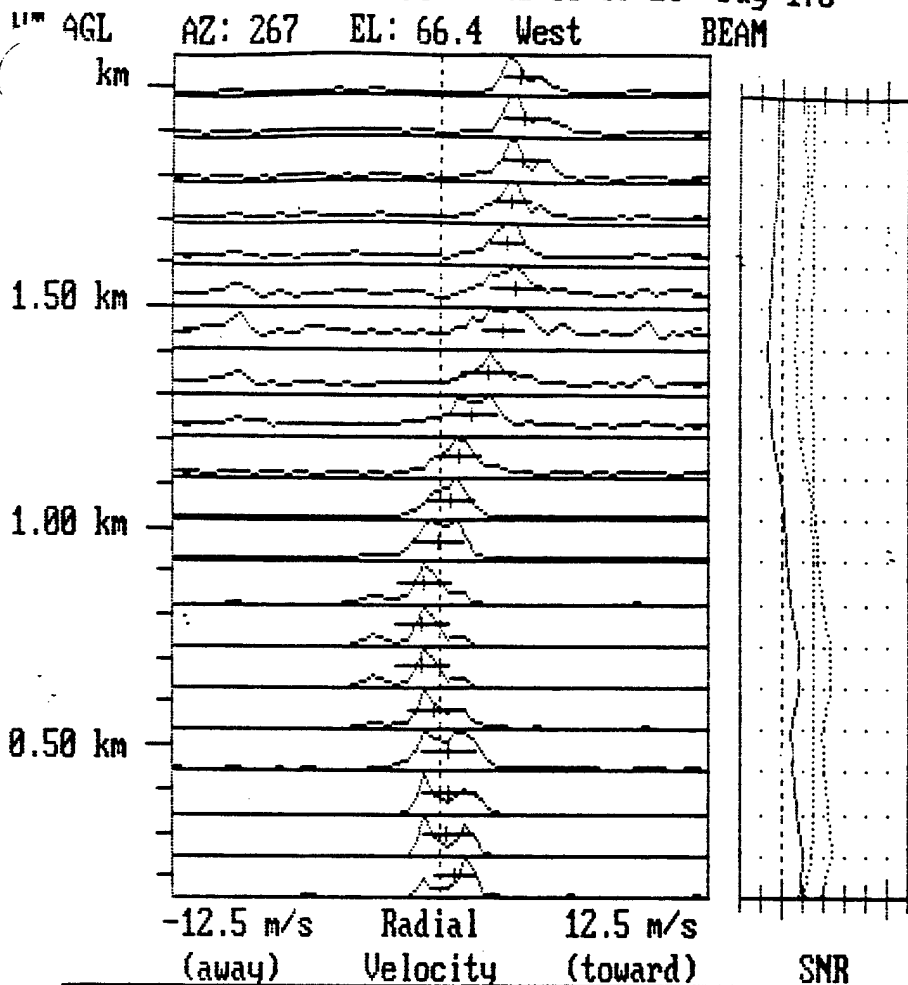

IPP: 20.000 μ sec
PW: 1.400
NCI: 324
NSP: 60
NHTS: 20
DLY: 2.000
SPAC: 0.700
NPTS: 64

CLUTTER RM @ 20 HTS
WINDOW+, DCFIL+
SPEC AVG: MEAN

LINEAR SPECTRA
NORMALIZED
GAIN = 1.000000
DISK WRITE: 3.4% FULL
HTS: ALL,PTS: ALL

[WSMR System - no changes]

[1.2 - 2 km] > ϕ m/s

8

DENVER WIT, LAP-3000, POP4
1998 Jun 19 Fri 11:54:54 LT Day 170
AZ: 357 EL: 66.4 North BEAM

SENSING FOR 30 MIN:
8 8 7 7 7

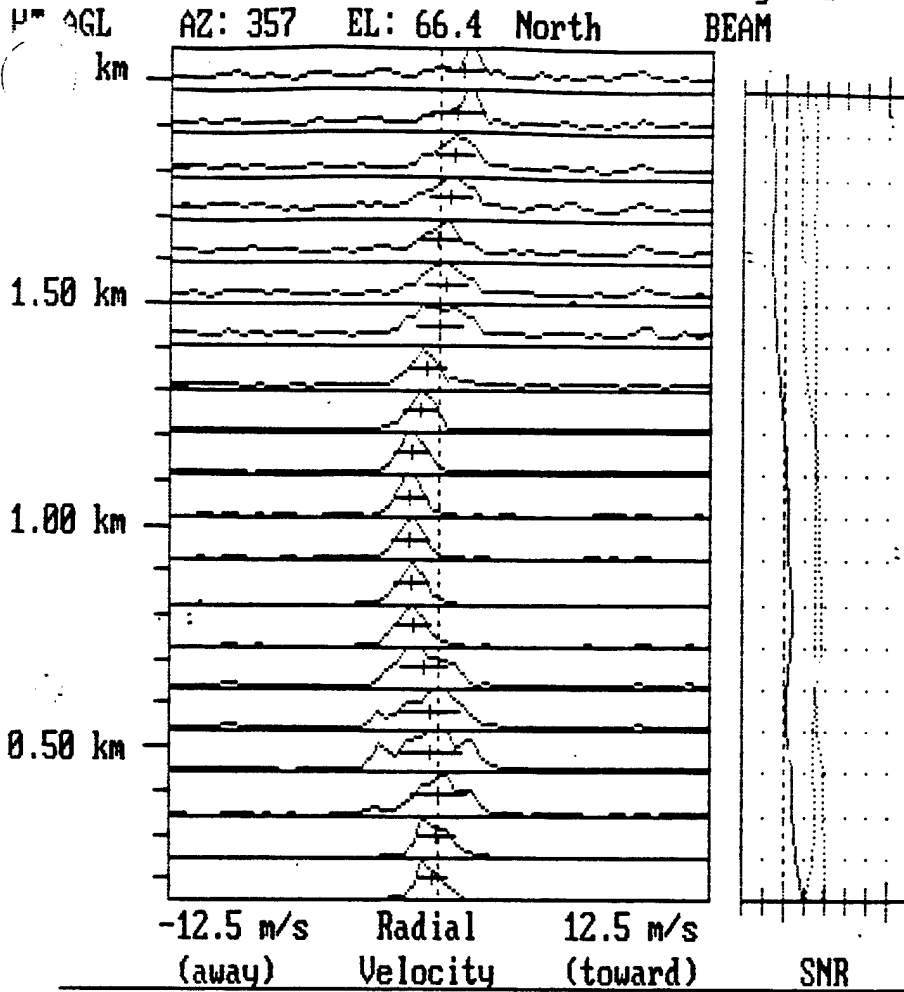

IPP: 20.000 μ sec
PW: 1.400
NCI: 324
NSP: 60
NHTS: 20
DLY: 2.000
SPAC: 0.700
NPTS: 64

CLUTTER RM @ 20 HTS
WINDOW+, DCFIL+
SPEC AVG: MEAN

LINEAR SPECTRA
NORMALIZED
GAIN = 1.000000
DISK WRITE: 3.4% FULL
HTS: ALL, PTS: ALL

[WSMR system - No changes]

[.6 - 1.3 Km] < Φ m/s

9

DENVER WIT, LAP-3000, POP4
1998 Jun 19 Fri 11:58:43 LT Day 170
AZ: 177 EL: 66.4 South BEAM

CONSENSING FOR 30 MIN:
9 9 9 9 8

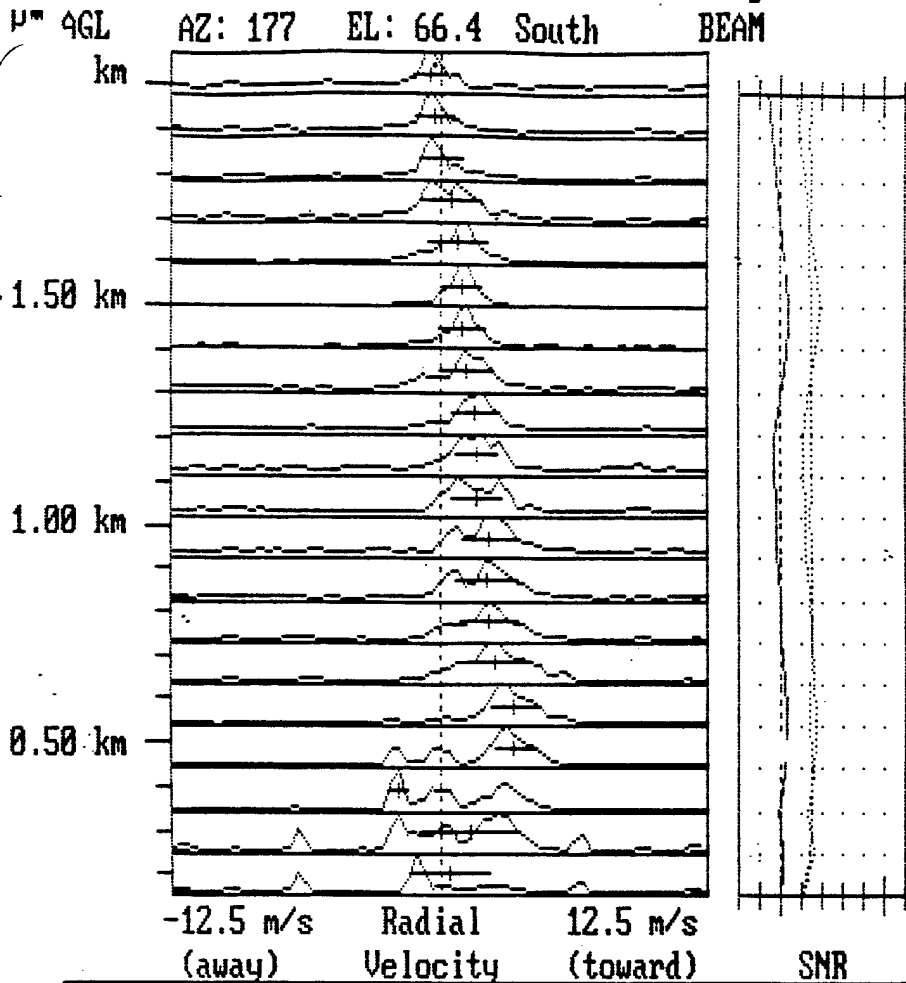

IPP: 20.000 μ sec
 PW: 1.400
 NCI: 324
 NSP: 60
 NHTS: 20
 DLY: 2.000
 SPAC: 0.700
 NPTS: 64

CLUTTER RM @ 20 HTS
 WINDOW+, DCFIL+
 SPEC AVG: MEAN

LINEAR SPECTRA
 NORMALIZED
 GAIN = 1.000000
 DISK WRITE: 3.4% FULL
 HTS: ALL, PTS: ALL

[WSMR System - no change]

[.6 - 1.6 km] > 0 m/s

DENVER WIT, LAP-3000, POP4
1998 Jun 19 Fri 12:23:25 LT Day 170
AZ: 357 EL: 90.0 X Vertical BEAM

CONSENSING FOR 30 MIN:
3 2 2 2 2

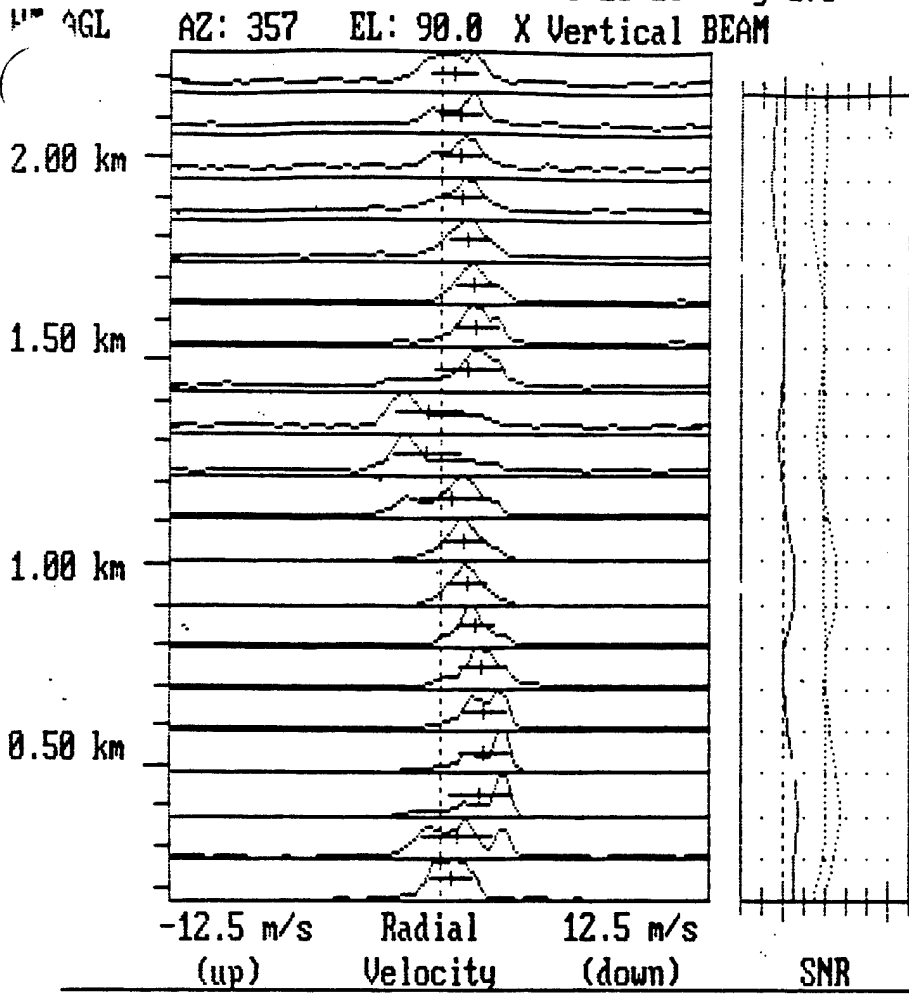

IPP: 20.000 µsec
PW: 1.400
NCI: 324
NSP: 60
NHTS: 20
DLY: 2.000
SPAC: 0.700
NPTS: 64

CLUTTER RM @ 18 HTS
WINDOW+, DCFIL+
SPEC AVG: MEAN

LINEAR SPECTRA
NORMALIZED
GAIN = 1.000000
DISK WRITE: 3.4% FULL
HTS: ALL,PTS: ALL

[WSAR System w/ARL Receiver]

DENVER WIT, LAP-3000, POP4
1998 Jun 19 Fri 12:21:07 LT Day 170
AZ: 357 EL: 66.4 North BEAM

CONSENSING FOR 30 MIN:
2 2 1 1 1

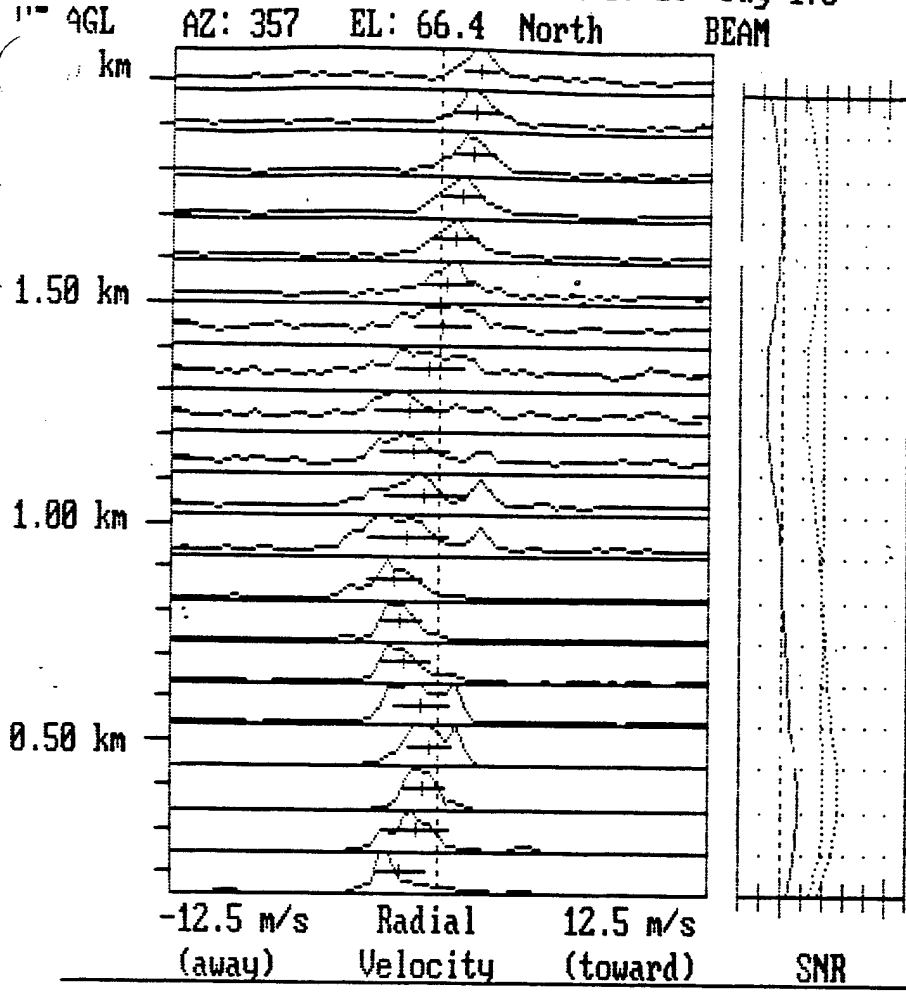

IPP: 20.000 μ sec
PW: 1.400
NCI: 324
NSP: 60
NHTS: 20
DLY: 2.000
SPAC: 0.700
NPTS: 64

CLUTTER RM @ 20 HTS
WINDOW+, DCFIL+
SPEC AVG: MEAN

LINEAR SPECTRA
NORMALIZED
GAIN = 1.000000
DISK WRITE: 3.4% FULL
HTS: ALL, PTS: ALL

[wsmr system w/ARL Receiver]

$[0 - 1.5] < 0 \text{ m/s}$

$[1.5 - 2] > 0 \text{ m/s}$

DENVER WIT, LAP-3000, POP4
1998 Jun 19 Fri 12:25:13 LT Day 170
AZ: 177 EL: 66.4 South BEAM

CONSENSING FOR 30 MIN:
3 3 3 3 2

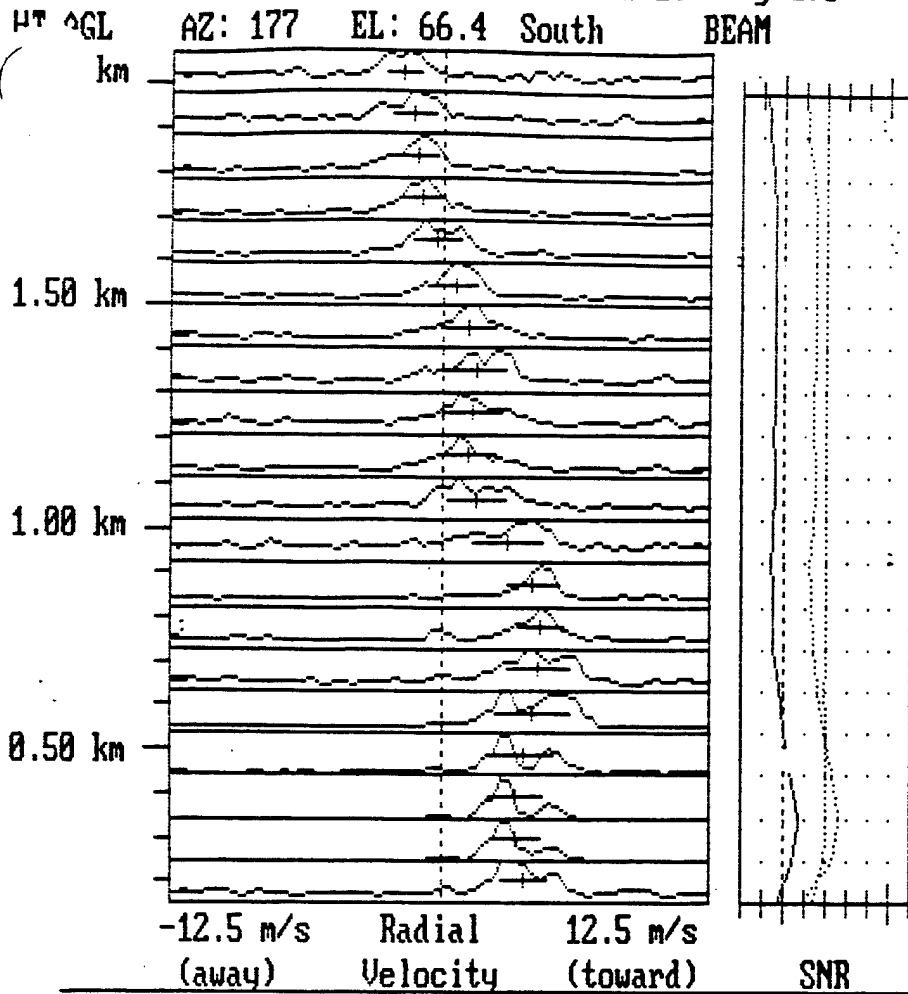

IPP: 20.000 μ sec
PW: 1.400
NCI: 324
NSP: 60
NHTS: 20
DLY: 2.000
SPAC: 0.700
NPTS: 64

CLUTTER RM @ 20 HTS
WINDOW+, DCFIL+
SPEC AVG: MEAN

LINEAR SPECTRA
NORMALIZED
GAIN = 1.000000
DISK WRITE: 3.4% FULL
HTS: ALL, PTS: ALL

[WSMR System - w/ ARL Receiver]

[0 - 1.5 Km] > ϕ

[1.5 - 2 Km] < ϕ

DENVER WIT, LAP-3000, POP4
1998 Jun 19 Fri 12:28:30 LT Day 170
AZ: 87 EL: 66.4 East BEAM

CONSENSING FOR 30 MIN:
4 4 4 4 4

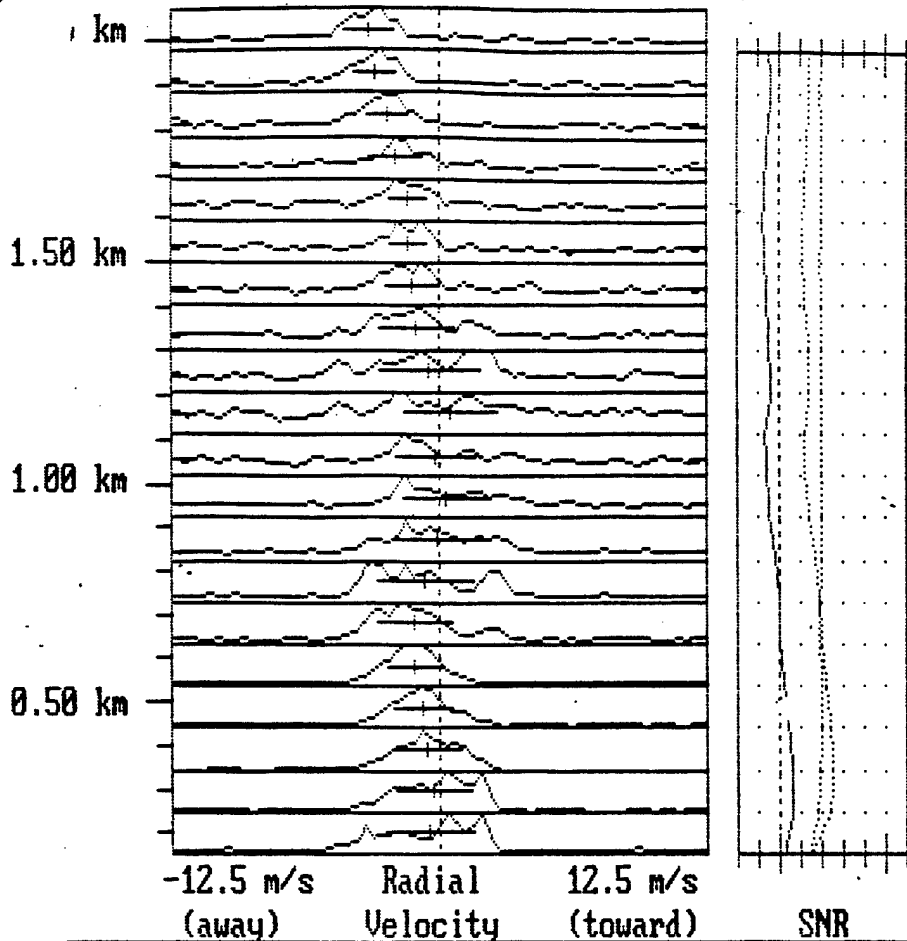

IPP: 20.000 μ sec
PW: 1.400
NCI: 324
NSP: 60
NHTS: 20
DLY: 2.000
SPAC: 0.700
NPTS: 64

CLUTTER RM @ 20 HTS
WINDOW+, DCFIL+
SPEC AVG: MEAN

LINEAR SPECTRA
NORMALIZED
GAIN = 1.000000
DISK WRITE: 3.4% FULL
HTS: ALL, PTS: ALL

[WSMK System w/ARL Receiver]

[.5 - 2 km] < Φ m/s

DENVER WIT, LAP-3000, POP4
1998 Jun 19 Fri 12:34:09 LT Day 170
AZ: 267 EL: 66.4 West BEAM

CONSENSING FOR 30 MIN:
2 2 2 1 1

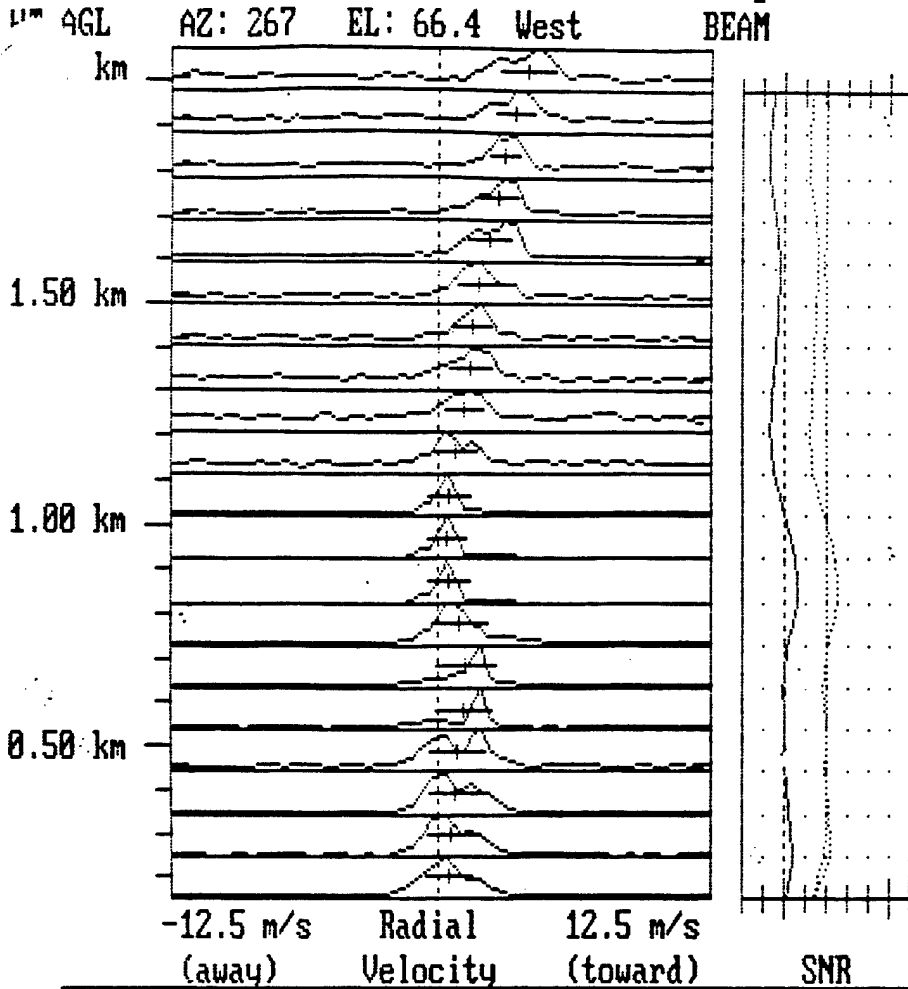

IPP: 20.000 μ sec
PW: 1.400
NCI: 324
NSP: 60
NHTS: 20
DLY: 2.000
SPAC: 0.700
NPTS: 64

CLUTTER RM @ 20 HTS
WINDOW+, DCFIL+
SPEC AVG: MEAN

LINEAR SPECTRA
NORMALIZED
GAIN = 1.000000
DISK WRITE: 3.4% FULL
HTS: ALL, PTS: ALL

[WSMR system w/ ARL Receiver]

[.5 \rightarrow 2 Km] > Φ m/s

15

DENVER WIT, LAP-3000, POP4
1998 Jun 19 Fri 13:22:41 LT Day 170
AZ: 357 EL: 90.0 X Vertical BEAM

CONSENSING FOR 30 MIN:
3 2 2 2 2

HT AGL

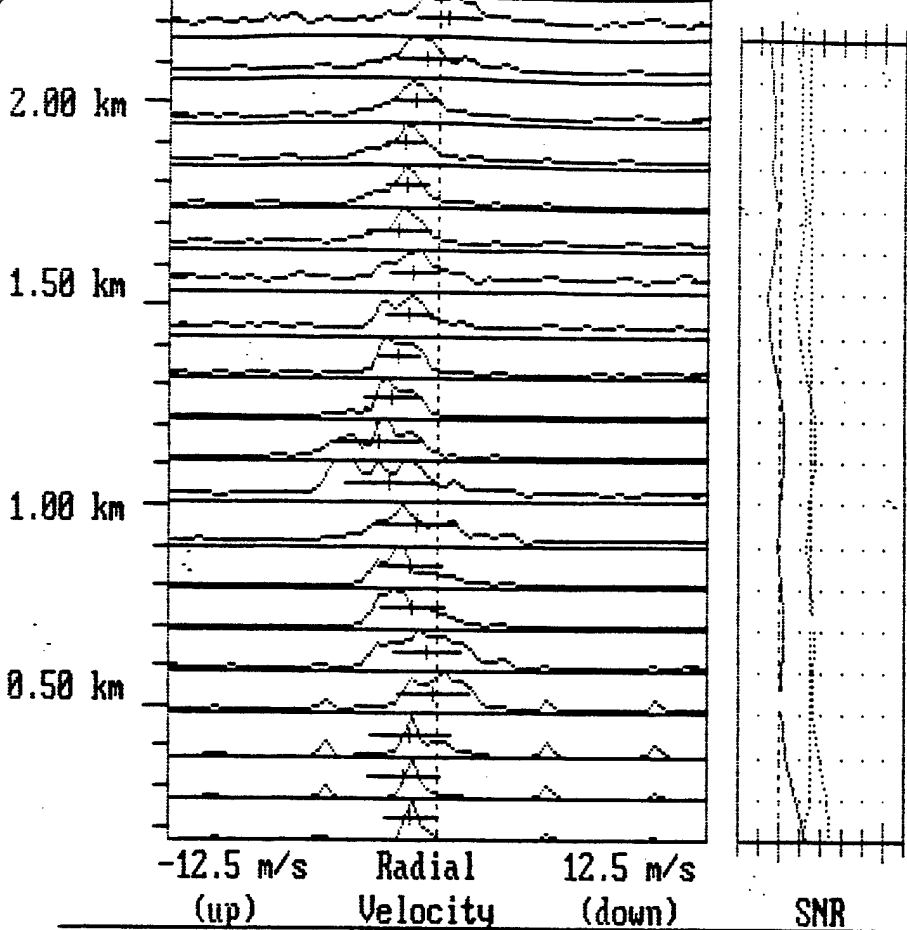

IPP: 20.000 μ sec
PW: 1.400
NCI: 324
NSP: 60
NHTS: 20
DLY: 2.000
SPAC: 0.700
NPTS: 64

CLUTTER RM @ 18 HTS
WINDOW+, DCFIL+
SPEC AVG: MEAN

LINEAR SPECTRA
NORMALIZED
GAIN = 1.000000
DISK WRITE: 3.4% FULL
HTS: ALL, PTS: ALL

[WSMR system w/ARL interface box]

[0 - 2 km] < 0 m/s

DENVER WIT, LAP-3000, POP4
1998 Jun 19 Fri 13:20:24 LT Day 170
AZ: 357 EL: 66.4 North BEAM

CONSENSING FOR 30 MIN:
2 2 1 1 1

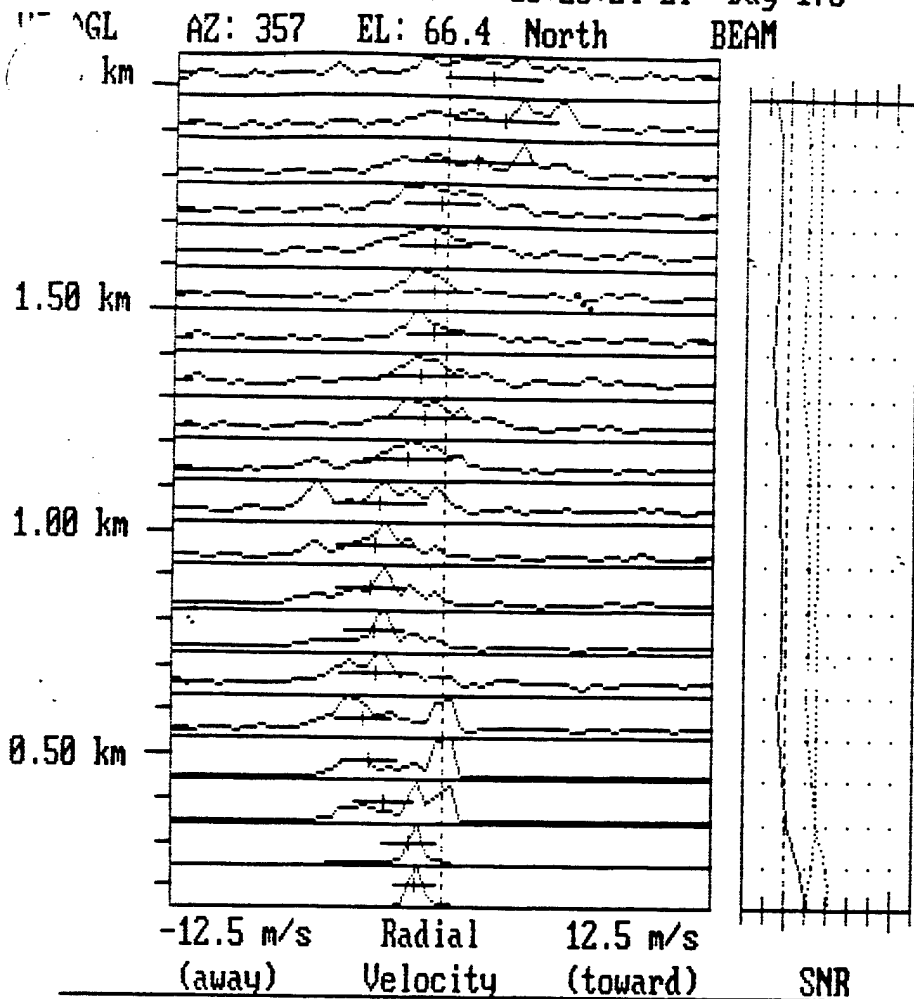

IPP: 20.000 μ sec
PW: 1.400
NCI: 324
NSP: 60
NHTS: 20
DLY: 2.000
SPAC: 0.700
NPTS: 64

CLUTTER RM @ 20 HTS
WINDOW+, DCFIL+
SPEC AVG: MEAN

LINEAR SPECTRA
NORMALIZED
GAIN = 1.000000
DISK WRITE: 3.4% FULL
HTS: ALL,PTS: ALL

[WCMR system - ARL interface box]

[.7 - 1.5 km] < 0 m/s

(17)

DENVER WIT, LAP-3000, POP4
1998 Jun 19 Fri 13:26:56 LT Day 170
AZ: 177 EL: 66.4 South BEAM

CONSENSING FOR 30 MIN:
4 4 4 4 3

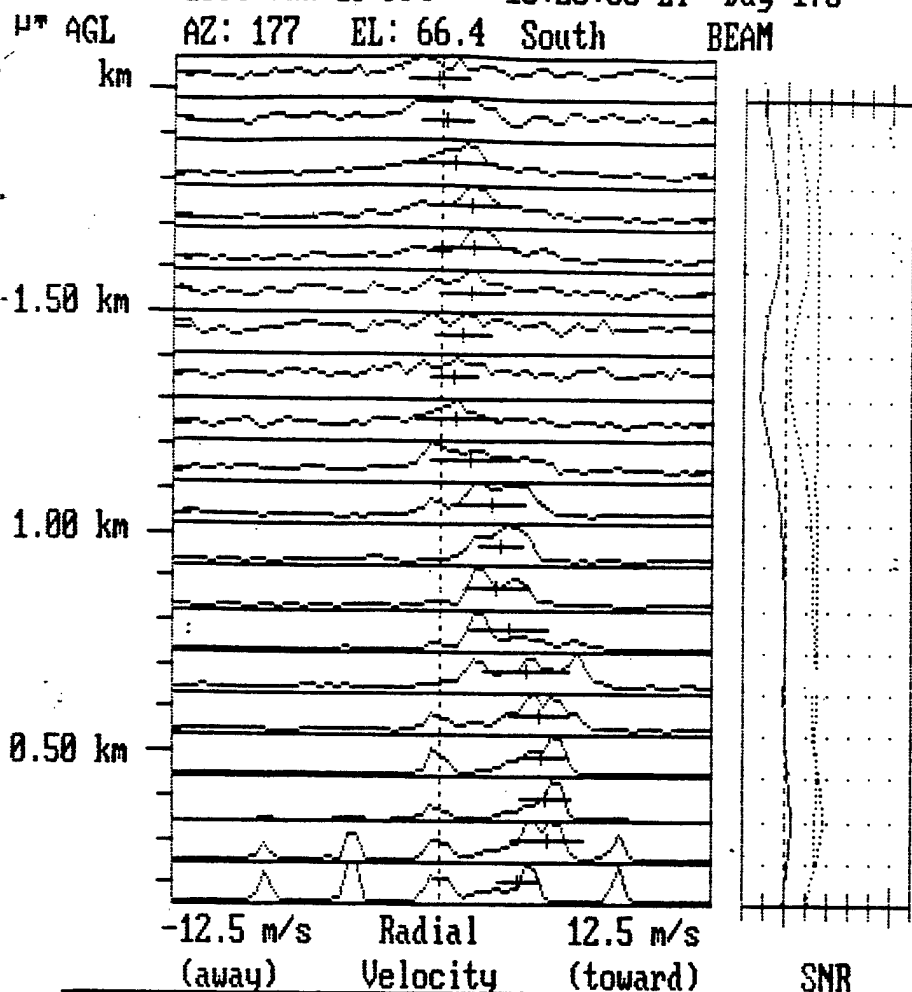

IPP: 20.000 μ sec
PW: 1.400
NCI: 324
NSP: 60
NHTS: 20
DLY: 2.000
SPAC: 0.700
NPTS: 64

CLUTTER RM @ 20 HTS
WINDOW+, DCFIL+
SPEC AVG: MEAN

LINEAR SPECTRA
NORMALIZED
GAIN = 1.000000
DISK WRITE: 3.4% FULL
HTS: ALL,PTS: ALL

[WSMR System w/ARI Interface Box]

[.5 - 1 km] > ϕ m/s

DENVER WIT, LAP-3000, POP4
 1998 Jun 19 Fri 13:18:06 LT Day 170
 AZ: 267 EL: 66.4 West BEAM

CONSENSING FOR 30 MIN:
 1 1 1 0 0

(18)

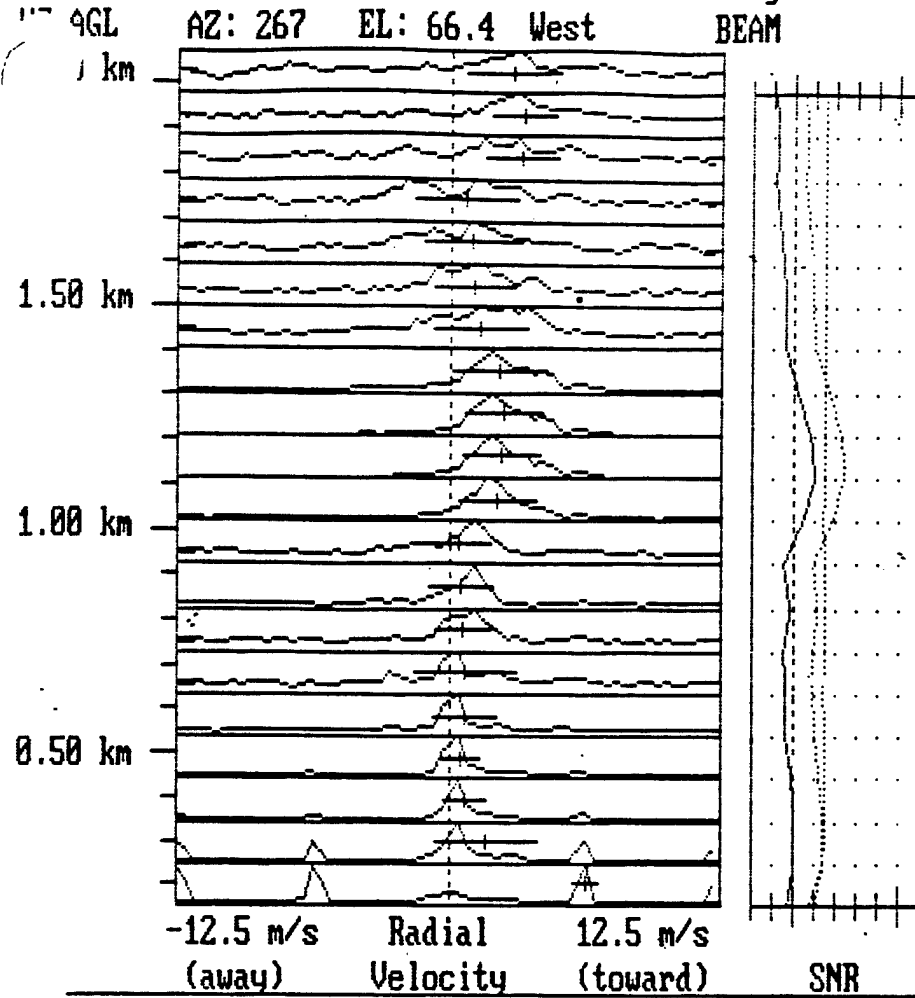

IPP: 20.000 μ sec
 PW: 1.400
 NCI: 324
 NSP: 60
 NHTS: 20
 DLY: 2.000
 SPAC: 0.700
 NPTS: 64

CLUTTER RM @ 20 HTS
 WINDOW+, DCFIL+
 SPEC AVG: MEAN

*system noise set @ 15 dB
 in Receiver box?*

LINEAR SPECTRA
 NORMALIZED
 GAIN = 1.000000
 DISK WRITE: 3.4% FULL
 HTS: ALL, PTS: ALL

[WSMR System w/ARL interface box]

[.5-2 km] > 0 m/s

DENVER WIT, LAP-3000, POP4
 1998 Jun 19 Fri 13:32:32 LT Day 170
 AZ: 87 EL: 66.4 East BEAM

CONSENSING FOR 30 MIN:
 1 1 1 1 1

19

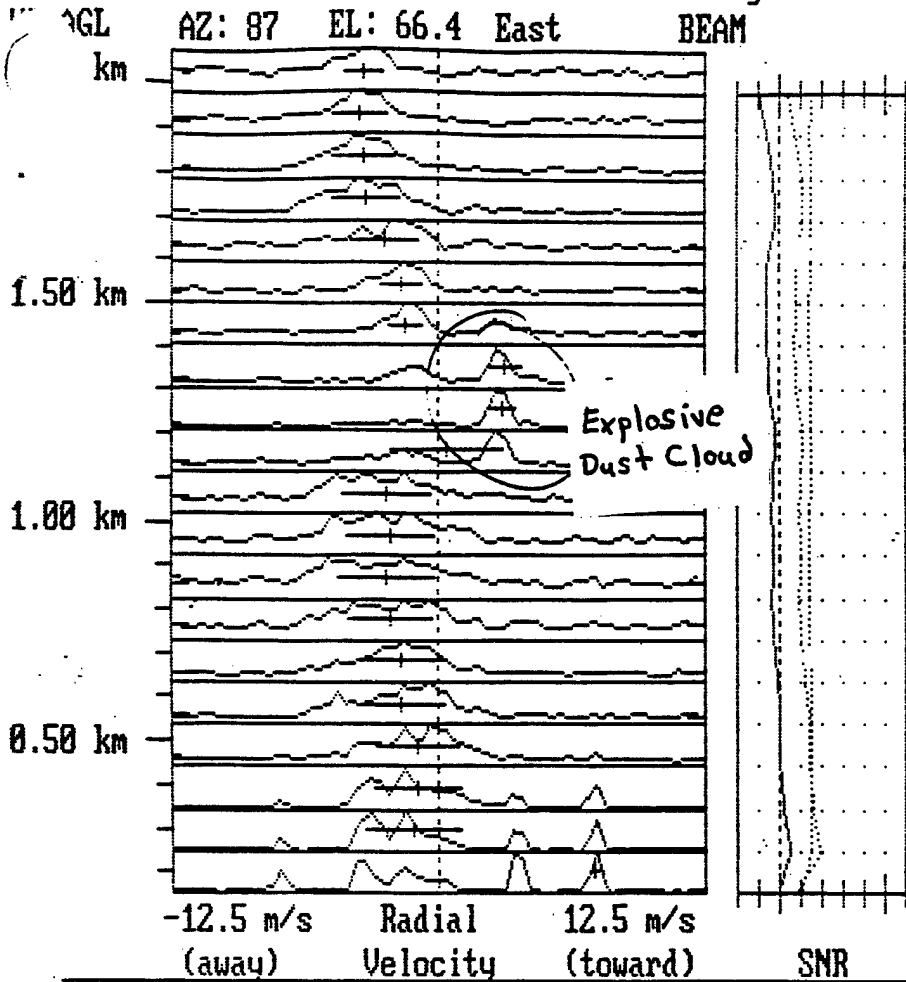

IPP: 20.000 μ sec
 PW: 1.400
 NCI: 324
 NSP: 60
 NHTS: 20
 DLY: 2.000
 SPAC: 0.700
 NPTS: 64

CLUTTER RM @ 20 HTS
 WINDOW+, DCFIL+
 SPEC AVG: MEAN

LINEAR SPECTRA
 NORMALIZED
 GAIN = 1.000000
 DISK WRITE: 3.4% FULL
 HTS: ALL,PTS: ALL

[WSMR system w/ARL Interface box]
 [0-1.1 km] and [1.4-2 km] < 0 m/s
 [1.1-3 km] > m/s

DENVER WIT, LAP-3000, POP4
 1998 Jun 19 Fri 13:37:08 LT Day 170
 AZ: 267 EL: 66.4 West BEAM

CONSENSING FOR 30 MIN:
 3 3 3 2 2

2C

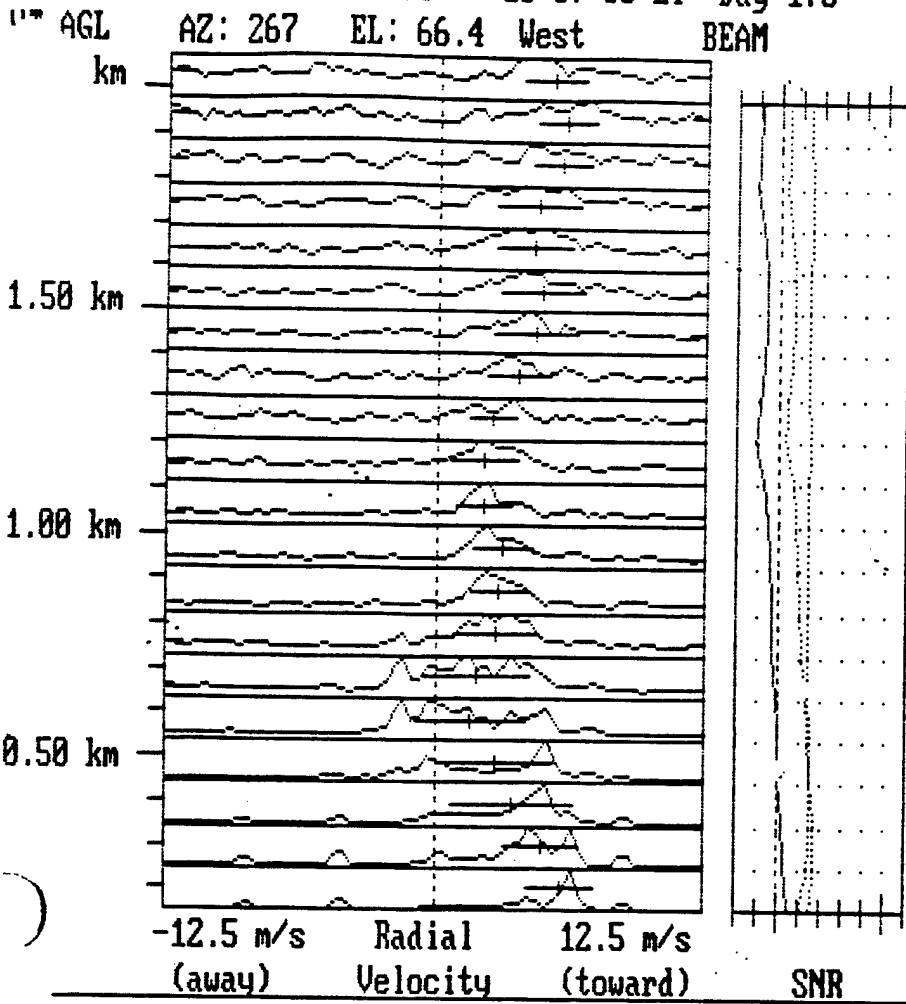

IPP: 20.000 μ sec
 PW: 1.400
 NCI: 324
 NSP: 60
 NHTS: 20
 DLY: 2.000
 SPAC: 0.700
 NPTS: 64

CLUTTER RM @ 20 HTS
 WINDOW+, DCFIL+
 SPEC AVG: MEAN

LINEAR SPECTRA
 NORMALIZED
 GAIN = 1.000000
 DISK WRITE: 3.4% FULL
 HTS: ALL, PTS: ALL

[WSMR System w/ARL Interface Box]

[0 - 2 Km] > ϕ m/s

DENVER WIT, LAP-3000, POP4
1998 Jun 19 Fri 13:46:50 LT Day 170
AZ: 267 EL: 66.4 West BEAM

CONSENSING FOR 30 MIN:
1 1 1 0 0

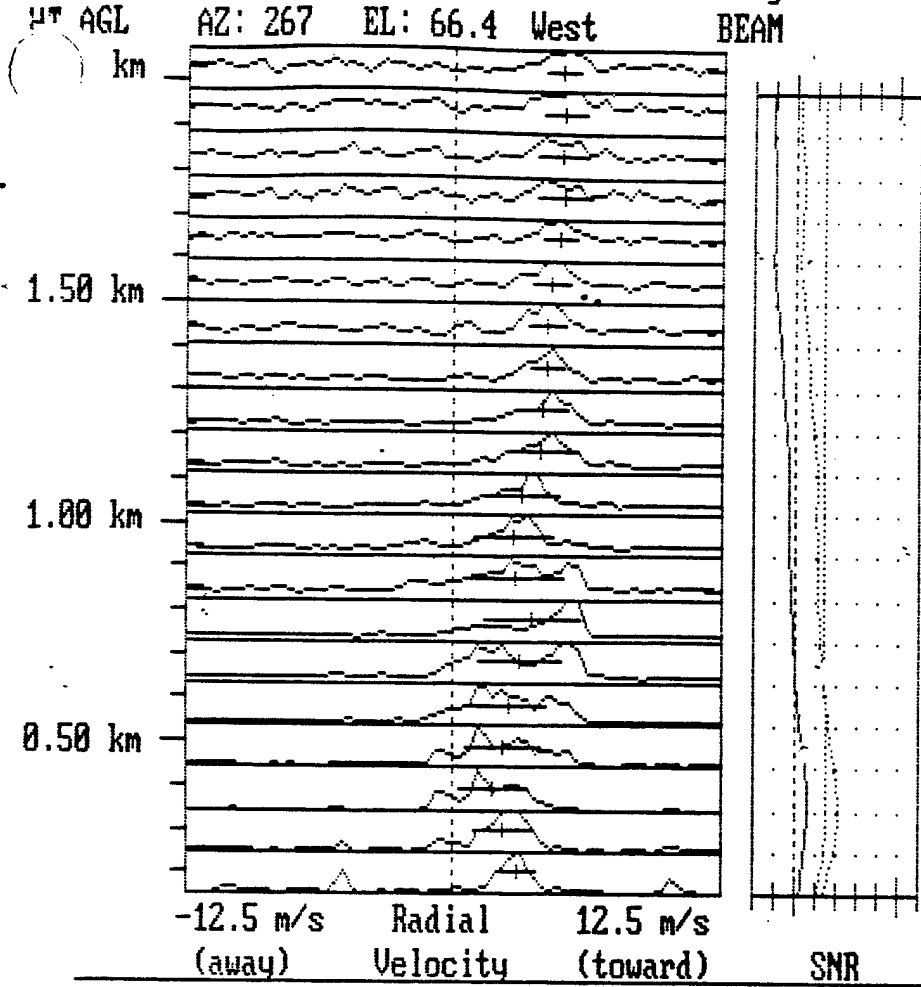

IPP: 20.000 μ sec
PW: 1.400
NCI: 324
NSP: 60
NHTS: 20
DLY: 2.000
SPAC: 0.700
NPTS: 64

CLUTTER RM @ 20 HTS
WINDOW+, DCFIL+
SPEC AVG: MEAN

LINEAR SPECTRA
NORMALIZED
GAIN = 1.000000
DISK WRITE: 3.4% FULL
HTS: ALL, PTS: ALL

[LUSMR System w/ARI Interface Box]

[0-2 km.] > ϕ m/s

DENVER WIT, LAP-3000, POP4
 1998 Jun 19 Fri 13:50:58 LT Day 170
 AZ: 87 EL: 66.4 East BEAM

CONSENSING FOR 30 MIN:
 2 2 2 2 2

22

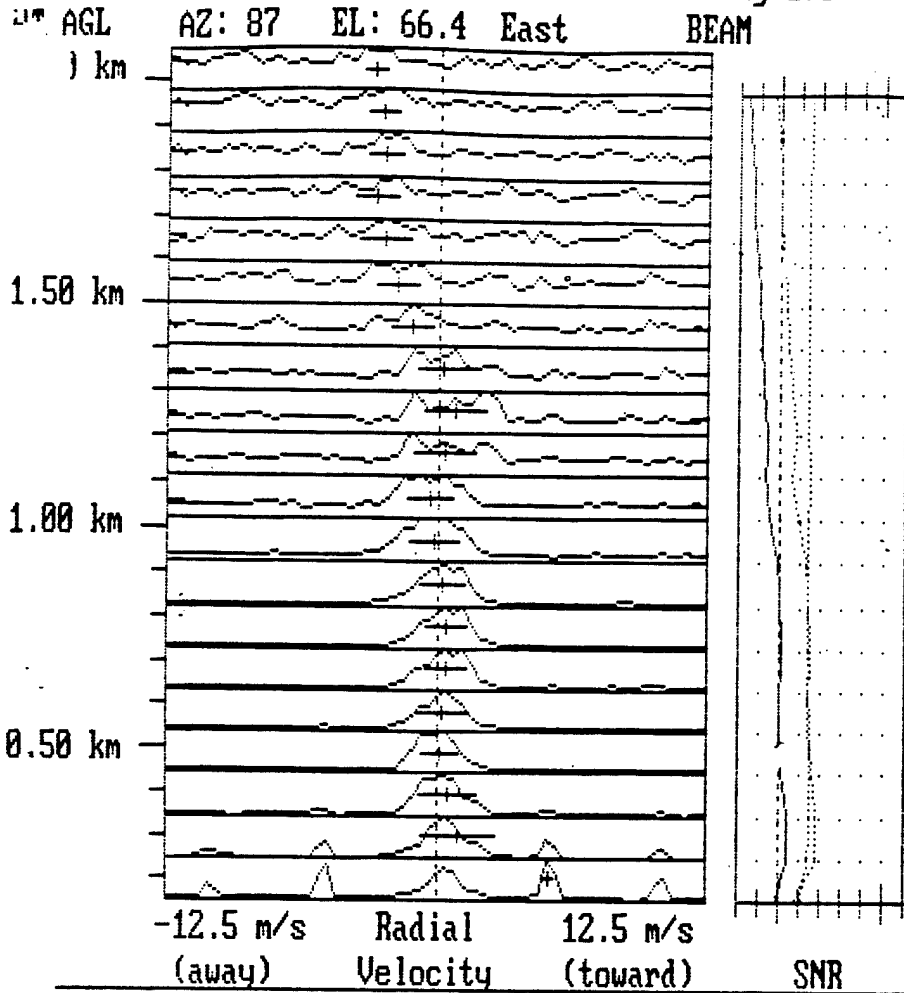

IPP: 20.000 μ sec
 PW: 1.400
 NCI: 324
 NSP: 60
 NHTS: 20
 DLY: 2.000
 SPAC: 0.700
 NPTS: 64

CLUTTER RM @ 20 HTS
 WINDOW+, DCFIL+
 SPEC AVG: MEAN

LINEAR SPECTRA
 NORMALIZED
 GAIN = 1.000000
 DISK WRITE: 3.4% FULL
 HTS: ALL, PTS: ALL

[WSMR system w/PL - late face box]

[1.5 - 2 km] $< \phi$ m/s

DATE: 98 170 TIME: 13:45 to 14:00

VERTICAL CORRECTION MADE

[98 June 19]

(23)

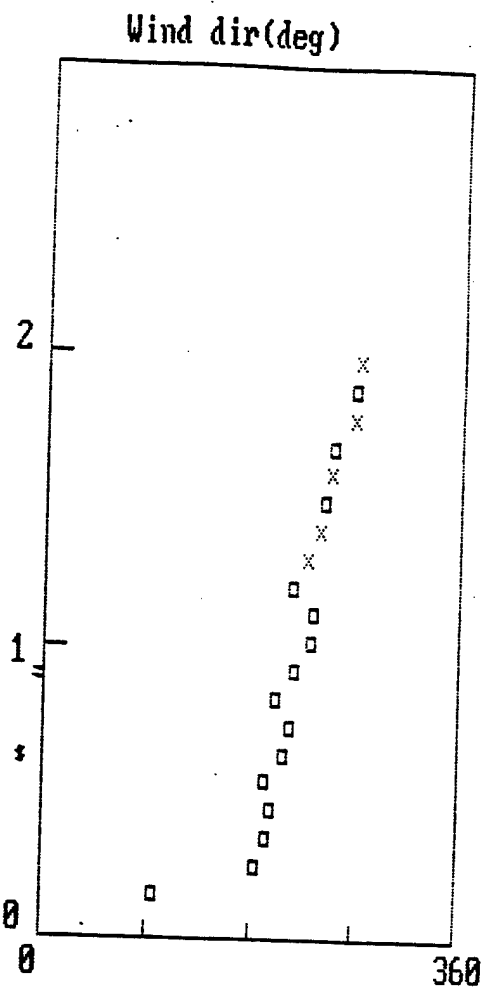
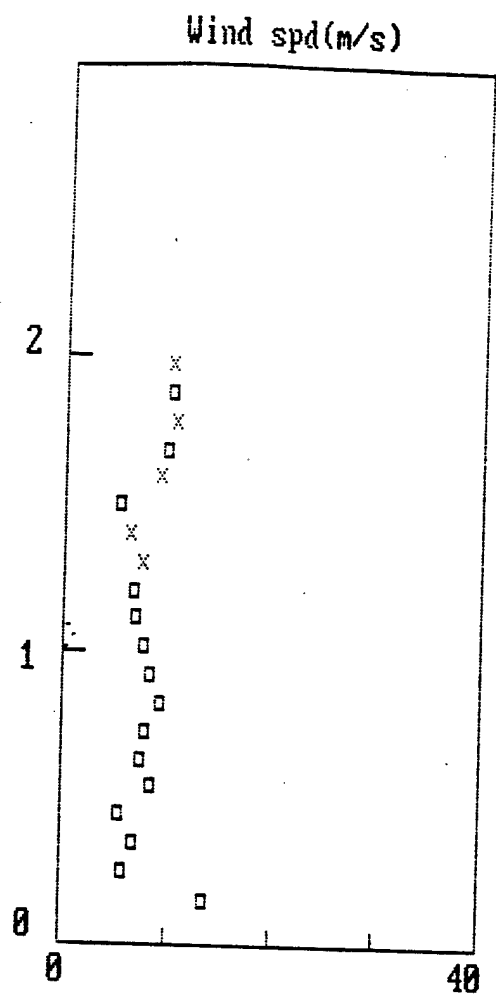

[WSMR System w/ ARL Interface Box]
□ = bogus data
x = real data

$\frac{1}{2}$ m consensus

MLRS - WSMIK/ARL Radar Components Tests

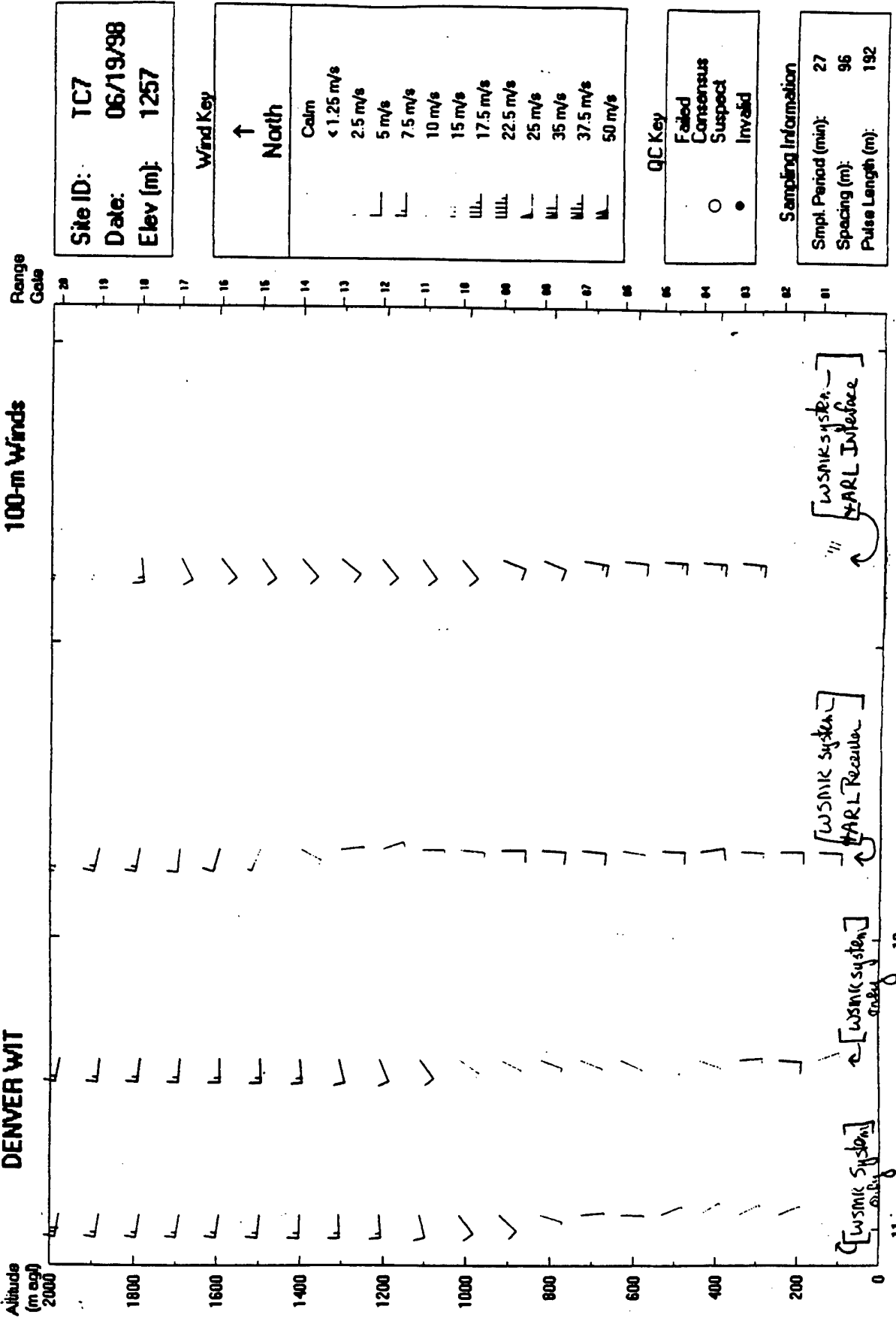

Site ID: TC7
Date: 06/19/98
Elev (m): 1257

Wind Key

North ↑

Calm
< 1.25 m/s
2.5 m/s
5 m/s
7.5 m/s
10 m/s
15 m/s
17.5 m/s
22.5 m/s
25 m/s
35 m/s
37.5 m/s
50 m/s

QC Key

Failed
Consensus
Suspect
Invalid

Sampling Information

Smpl. Period (min): 27
Spacing (m): 96
Pulse Length (m): 192

Validation Lvl: 0.0
Filename: TC780618.W3A
Product: MLRS

(2)

DENVER WIT, LAP-3000, POP4
1998 Jun 19 Fri 14:18:55 LT Day 170
AZ: 357 EL: 66.4 North BEAM

CONSENSING FOR 30 MIN:
1 1 0 0 0

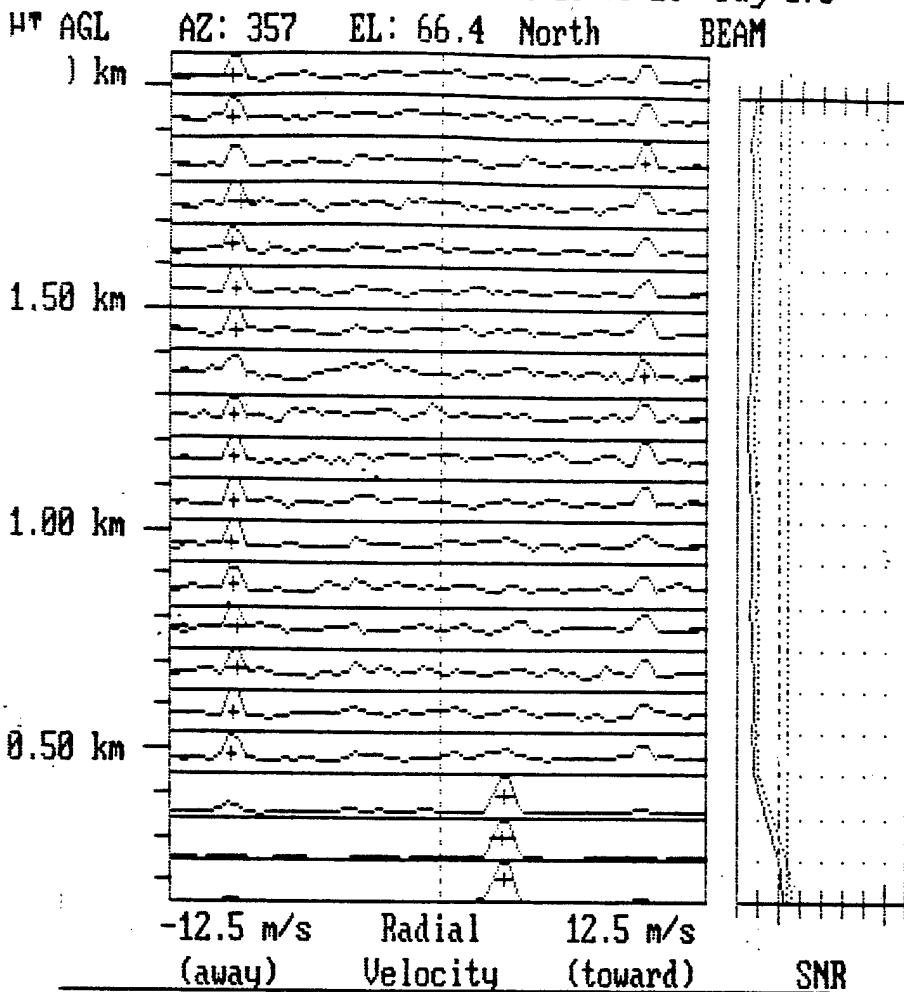

IPP: 20.000 μ sec
PW: 1.400
NCI: 324
NSP: 60
NHTS: 20
DLY: 2.000
SPAC: 0.700
NPTS: 64

CLUTTER RM @ 20 HTS
WINDOW+, DCFIL+
SPEC AUG: MEAN

LINEAR SPECTRA
NORMALIZED
GAIN = 1.000000
DISK WRITE: 3.4% FULL
HTS: ALL, PTS: ALL

Power = generator
WSMR Computer + Radar
POP4 - WSMR system
ARL Receiver + Interface Box
Tx-out is off
Receiver-in @ 50- Ω Terminator
200m double sampling

60 Hz Peaks should be @ 8.8 m/s

Note: Gates 1-3

DENVER WIT, LAP-3000, POP4
1998 Jun 19 Fri 14:23:30 LT Day 170
AZ: 357 EL: 90.0 X Vertical BEAM

CONSENSING FOR 30 MIN:
3 2 2 2 2

HT AGL

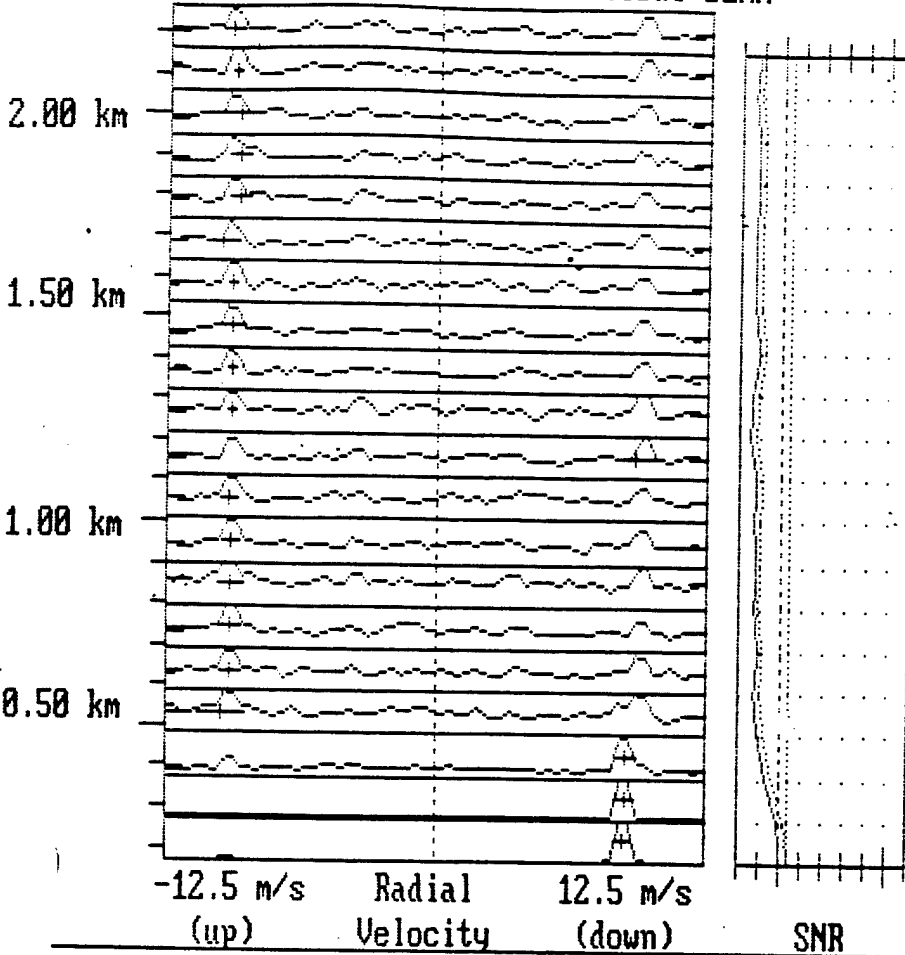

IPP: 20.000 μ sec
PW: 1.400
NCI: 324
NSP: 60
NHTS: 20
DLY: 2.000
SPAC: 0.700
NPTS: 64

CLUTTER RM @ 18 HTS
WINDOW+, DCFIL+
SPEC AUG: MEAN

LINEAR SPECTRA
NORMALIZED
GAIN = 1.000000
DISK WRITE: 3.4% FULL
HTS: ALL, PTS: ALL

Power = generator
WSMR Computer (POP4) + Radar (924 MHz)
ARL Receiver + Interface Box
TX-out is off
Receiver-in @ 50- Ω Terminator
200m double sampling

Note: gates 1-3

27

DENVER WIT, LAP-3000, POP4
1998 Jun 19 Fri 14:27:09 LT Day 170
AZ: 267 EL: 66.4 West BEAM

CONSENSING FOR 30 MIN:
4 4 4 3 3

HT AGL

3 km

1.50 km

1.00 km

0.50 km

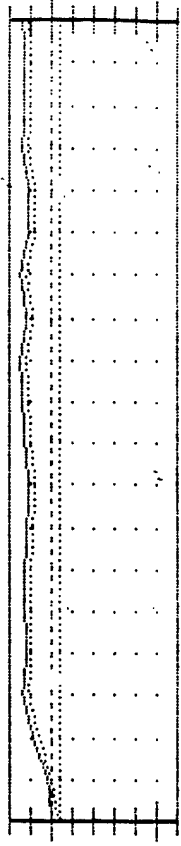
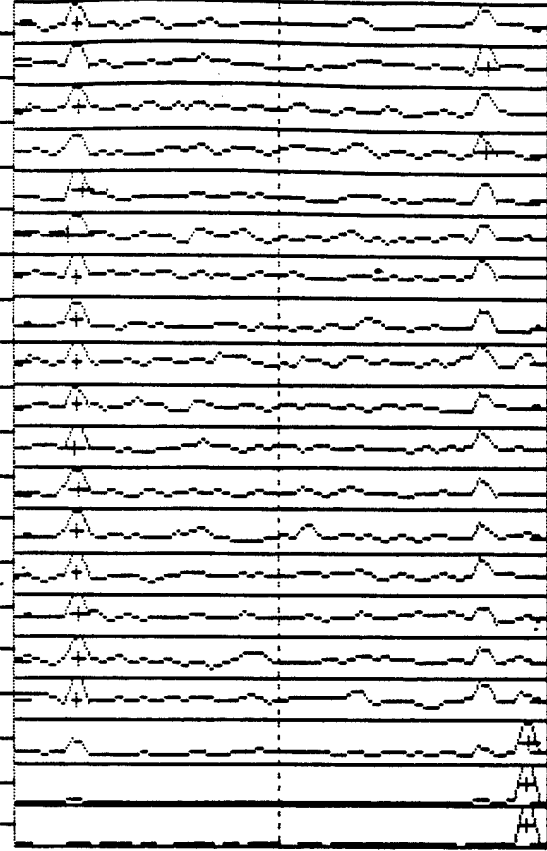

-12.5 m/s Radial 12.5 m/s
(away) Velocity (toward)

SNR

IPP: 20.000 μ sec
PW: 1.400
NCI: 324
NSP: 60
NHTS: 20
DLY: 2.000
SPAC: 0.700
NPTS: 64

CLUTTER RM @ 20 HTS
WINDOW+, DCFIL+
SPEC AVG: MEAN

LINEAR SPECTRA
NORMALIZED
GAIN = 1.000000
DISK WRITE: 3.4% FULL
HTS: ALL, PTS: ALL

Power = generator
WSMR Computer (POP4) + Radar
ARL Receiver + Interface Box
Tx is off
RC @ 50 Ω Terminator
500m double sampling

Note: Gates 1-3



DENVER WIT, LAP-3000, POP4
1998 Jun 19 Fri 14:30:42 LT Day 170
AZ: 357 EL: 90.0 X Vertical BEAM

CONSENSING FOR 30 MIN:
1 0 0 0 0

28

HT AGL

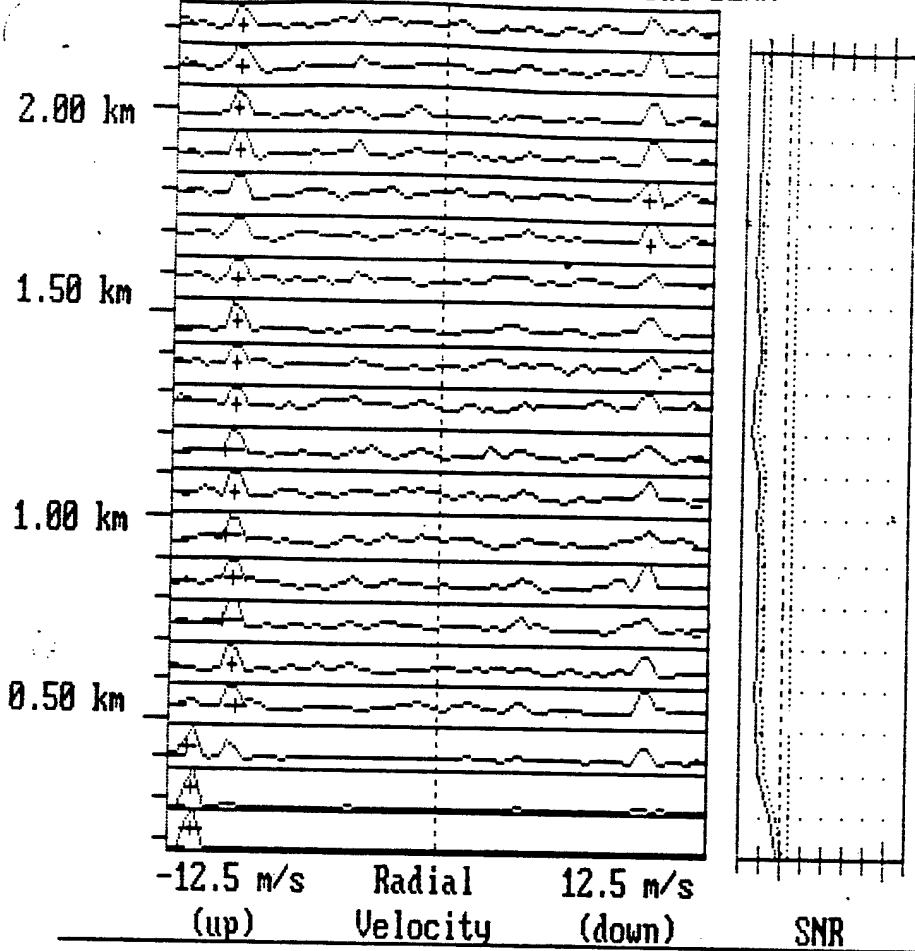

IPP: 20.000 μ sec
PW: 1.400
NCI: 324
NSP: 60
NHTS: 20
DLY: 2.000
SPAC: 0.700
NPTS: 64

CLUTTER RM @ 18 HTS
WINDOW+, DCFIL+
SPEC AVG: MEAN

LINEAR SPECTRA
NORMALIZED
GAIN = 1.000000
DISK WRITE: 3.4% FULL
HTS: ALL, PTS: ALL

Power = generate
WSMR computer (POP4) + Radar
POP4 -
ARL Receiver + Interface Box
TX-out is off
Receiver-in @ 50 Ω Terminate
200m double sampling

Note: Gates 1-3

DENVER WIT, LAP-3000, POP4
1998 Jun 19 Fri 14:40:02 LT Day 170
AZ: 87 EL: 66.4 East BEAM

CONSENSING FOR 30 MIN:
4 4 4 4 4

HT AGL

3 km

1.50 km

1.00 km

0.50 km

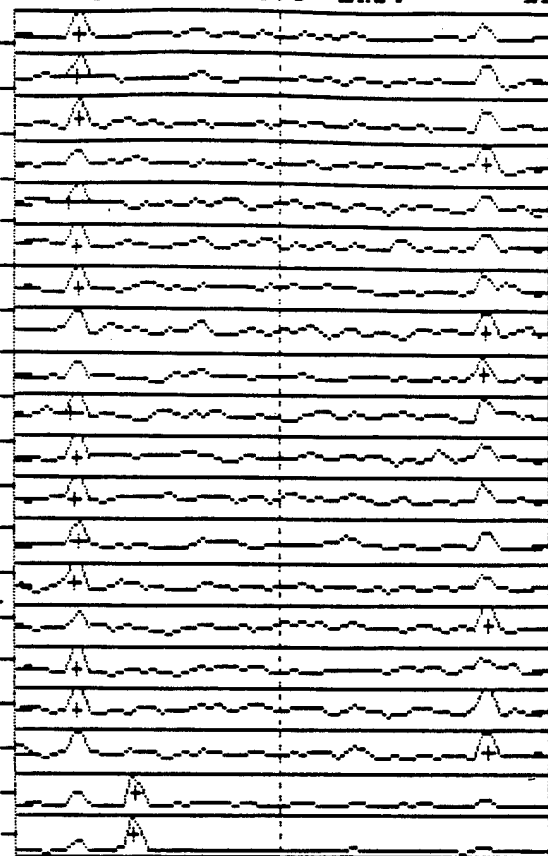

-12.5 m/s Radial 12.5 m/s
(away) Velocity (toward)

SNR

IPP: 20.000 μ sec
PW: 1.400
NCI: 324
NSP: 60
NHTS: 20
DLY: 2.000
SPAC: 0.700
NPTS: 64

CLUTTER RM @ 20 HTS
WINDOW+, DCFIL+
SPEC AVG: MEAN

LINEAR SPECTRA
NORMALIZED
GAIN = 1.000000
DISK WRITE: 3.4% FULL
HTS: ALL, PTS: ALL

Power = generate
WSMR Computer + Radar (POP4)
ARL Receiver + Interface Box
TX is off
Re @ 50 Ω Terminator
200m double Sampling

Note: Gates 1-3

30

DENVER WIT, LAP-3000, POP4
1998 Jun 19 Fri 15:20:35 LT Day 170
AZ: 267 EL: 66.4 West BEAM

CONSENSING FOR 30 MIN:
9 9 9 8 8

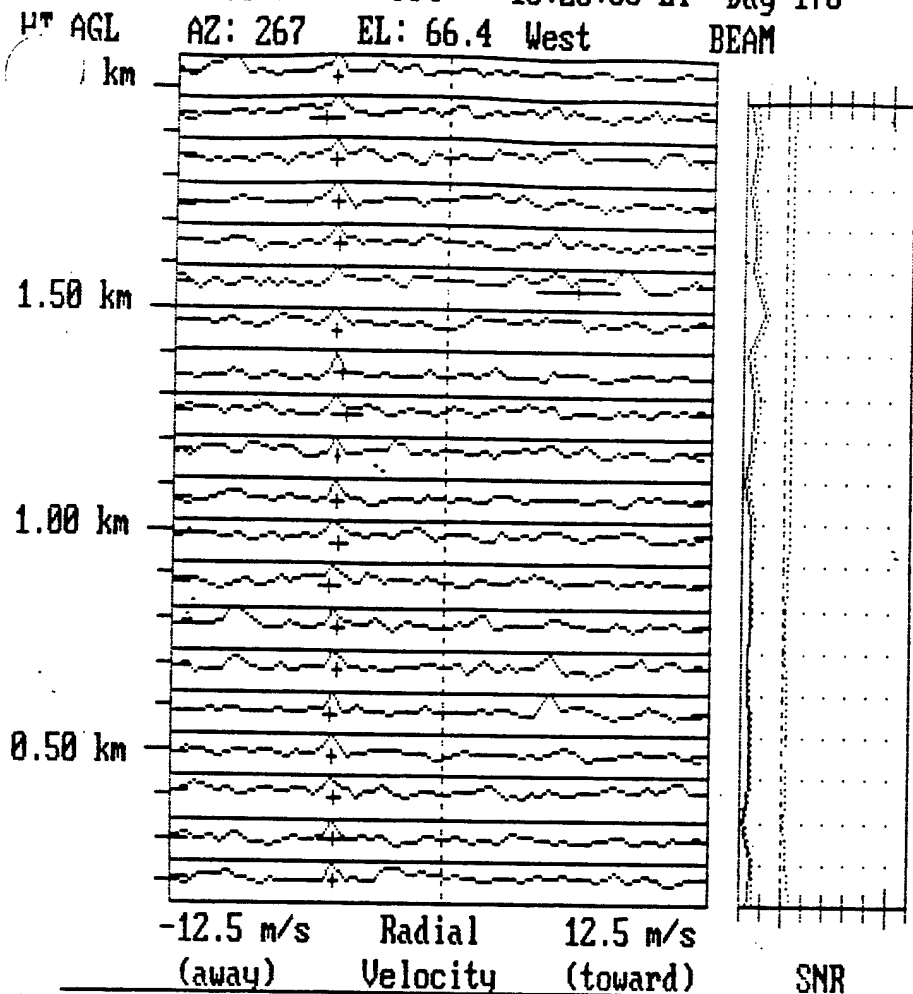

IPP: 20.000 μ sec
PW: 1.400
NCI: 324
NSP: 60
NHTS: 20
DLY: 2.000
SPAC: 0.700
NPTS: 64

CLUTTER RM @ 20 HTS
WINDOW+, DCFIL+
SPEC AUG: MEAN

LINEAR SPECTRA
NORMALIZED
GAIN = 1.000000
DISK WRITE: 3.4% FULL
HTS: ALL, PTS: ALL

WSMR Computer (POP4), Receiver
ARL Interface Box only
TX off
Receiver @ 50 Ω

-6 m/s peak is unexpected.

DENVER WIT, LAP-3000, POP4
1998 Jun 19 Fri 15:15:31 LT Day 170
AZ: 267 EL: 66.4 West BEAM

CONSENSING FOR 30 MIN:
7 7 7 6 6

HT AGL
7 km

1.50 km

1.00 km

0.50 km

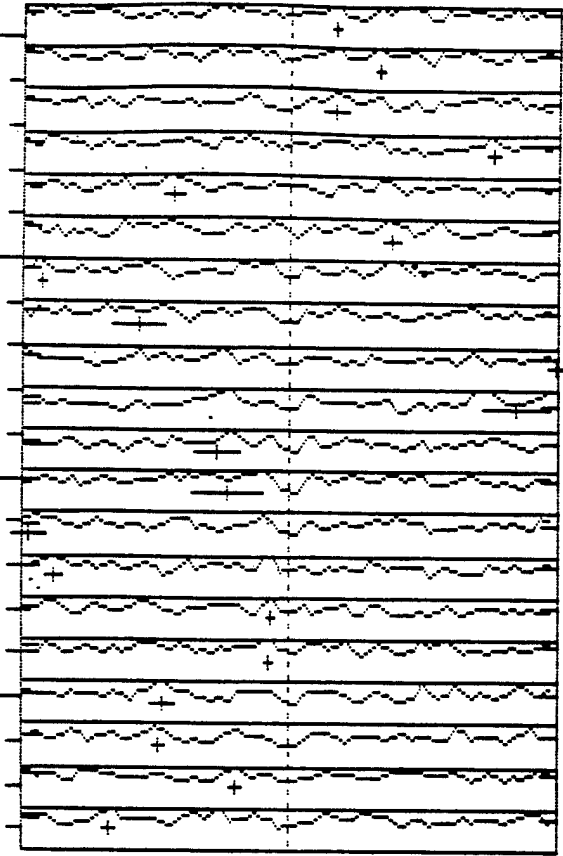

-12.5 m/s Radial 12.5 m/s
(away) Velocity (toward)

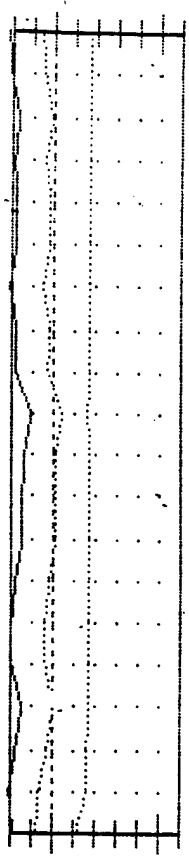

SNR

IPP: 20.000 psec
PW: 1.400
NCI: 324
NSP: 60
NHTS: 20
DLY: 2.000
SPAC: 0.700
NPTS: 64

CLUTTER RM @ 20 HTS
WINDOW+, DCFIL+
SPEC AVG: MEAN

LINEAR SPECTRA
NORMALIZED
GAIN = 1.000000
DISK WRITE: 3.4% FULL
HTS: ALL,PTS: ALL

WSMR Computer, Receiver, {Amp, Pre-Amp = output amp}
ARL Interface Box
out Pre-Amp have 50Ω Terminator @ SMA connector to antenna
TX off

Results are as expected

Denver WIT, WEMK - 6/22/98

System Parameters:

MLRS1.PAR

1 of 2

Radar Name: LAP-3000□□
Code: 7
Operating Frequency: 924.00 MHz
Maximum TX Duty: 12.00 %
Maximum Pulse Length: 12 microseconds
Minimum IPP: 20 microseconds
Clock Cycle: 100 nanoseconds
PRE-TTR: 1500 nanoseconds
Post-TTR: 200 nanoseconds
PRE-Blank: 1500 nanoseconds
Post-Blank: 700 nanoseconds
Synch: 200 nanoseconds
Antenna Type: 5 beam phased

Pulse Width System Delay
(nanosecs) (nanosecs)

400	800
700	850
1400	900
2800	1000

Site Parameters:

Site Name: DENVER WIT□□
Latitude: 33.25 Degrees North
Longitude: 106.36 Degrees West
Coordinated Universal Time Correction: 7.00 Hours
Site Altitude: 1257 Meters

Direction Azimuth Zenith Axis Direction Code

	Azimuth	Zenith	Axis	Direction Code
	Degrees	Degrees		
X Vertical□□	357	0.0	XV	0
Y Vertical□□	267	0.0	YV	1
North □□	357	23.6	X+	2
West □□	267	23.6	Y+	3
South □□	177	23.6	X-	4
East □□	87	23.6	Y-	5

Parameter Sets and Beam Sequencing:

Averaging Time in Minutes for the Wind Consensus: 30
RASS is always OFF.

Beam Sequencing Information

Seq #:	Ant Dir:	Num Reps:	Par Set #:
1	X Vertical□□	1	1
2	North □□	1	1
3	West □□	1	1
4	South □□	1	1
5	East □□	1	1

Parameter Set #s:	1	2	3	4
IPP (microsecs):	20	50	43	20
Pulse Width (nanosecs):	1400	1400	2800	400
Dwell (nanosecs):	2000	2200	3300	1600
Gate Width (nanosecs):	700	1400	1400	400
# Gate Heights:	20	25	22	25
# Coherent Integrations:	324	130	180	10
# points in FFT:	64	64	64	64
# Spectra averaged:	60	62	42	20
# Code Bits:	0	4	0	0
TX Duty (%):	7.00	11.20	6.51	2.00
Dwell Time (secs):	28.04	29.28	23.69	2.74
Full Scale Velocity (m/s):	12.53	12.49	10.49	405.84
First Gate Height (m AGL):	165	195	345	120
Last Gate Height (m AGL):	2160	5235	4755	1560

WIND, WIND - 010017

2 of 2

Wind processing parameters:

Consensus Averaging window: Oblique modes = 4.00 m/s Vertical mode = 2.00 m/s
 Percent required to pass consensus: Oblique modes = 60 % Vertical mode = 60 %
 Max Height for clutter removal = 2000 meters.
 The Vertical beam will be used in wind calculations.
 The mean wind spectral averaging routine will be used.

I/O Parameters:

Auto start disabled.
 No hard copies generated.
 Data height measurements are recorded as above ground level.
 EGA monitor being used as display device.
 Moment data will be written to c:\radar\data\
 Consensus averaged data will be written to c:\radar\data\ directory.
 LAP will run in real time mode.
 LAP will not recalculate moments data from archived spectral data products.
 Log data will be written to c:\radar\data\D95132a.LOG

DENVER WIT, LAP-3000, POP4
1998 Jun 22 Mon 11:06:25 LT Day 173
AZ: 357 EL: 90.0 X Vertical BEAM

CONSENSING FOR 30 MIN:
1 0 0 0 0

M* AGL

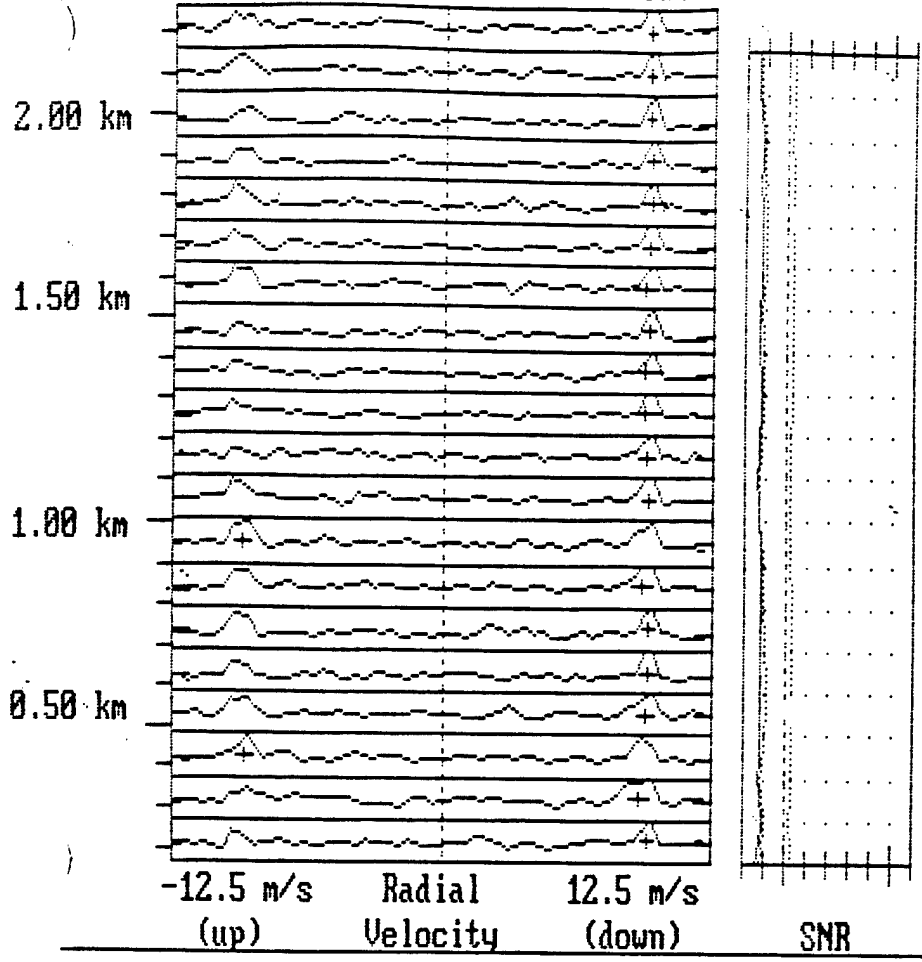

IPP: 20.000 μ sec
PW: 1.400
NCI: 324
NSP: 60
NHTS: 20
DLY: 2.000
SPAC: 0.700
NPTS: 64

CLUTTER RM @ 18 HTS
WINDOW+, DCFIL+
SPEC AVG: MEAN

LINEAR SPECTRA
NORMALIZED
GAIN = 1.000000
DISK WRITE: 3.4% FULL
HTS: ALL, PTS: ALL

WSMR system only

"60Hz Test"

TX off
RC in 50 Ω Terminator
generator power

Symmetric Peaks @ ± 8.8 m/s

DENVER WIT, LAP-3000, POP4
1998 Jun 22 Mon 11:08:46 LT Day 173
AZ: 87 EL: 66.4 East BEAM

CONSENSING FOR 30 MIN:
1 1 1 1 1

33

H^T AGL

km
1.50 km
1.00 km
0.50 km

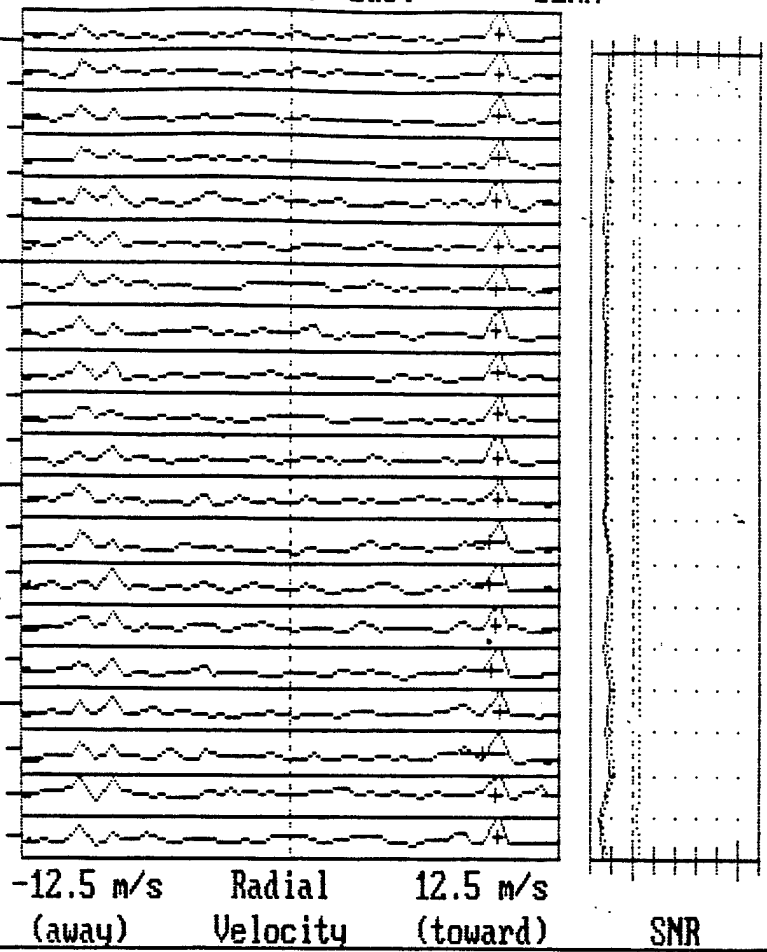

IPP: 20.000 μ sec
PW: 1.400
NCI: 324
NSP: 60
NHTS: 20
DLY: 2.000
SPAC: 0.700
NPTS: 64

CLUTTER RM @ 20 HTS
WINDOW+, DCFIL+
SPEC AVG: MEAN

LINEAR SPECTRA
NORMALIZED
GAIN = 1.000000
DISK WRITE: 3.4% FULL
HTS: ALL, PTS: ALL

WSMR system only
generator power
TX off
RC-in 50 Ω Terminator

"60Hz Test"

Peaks @ ± 8.8 m/s
Dual Peaks at -8.8 m/s function of generator power
Peaks were consistent, no migration

DENVER WIT, LAP-3000, POP4
1998 Jun 22 Mon 11:17:52 LT Day 173
AZ: 357 EL: 90.0 X Vertical BEAM

CONSENSING FOR 30 MIN:
1 0 0 0 0

HT AGL

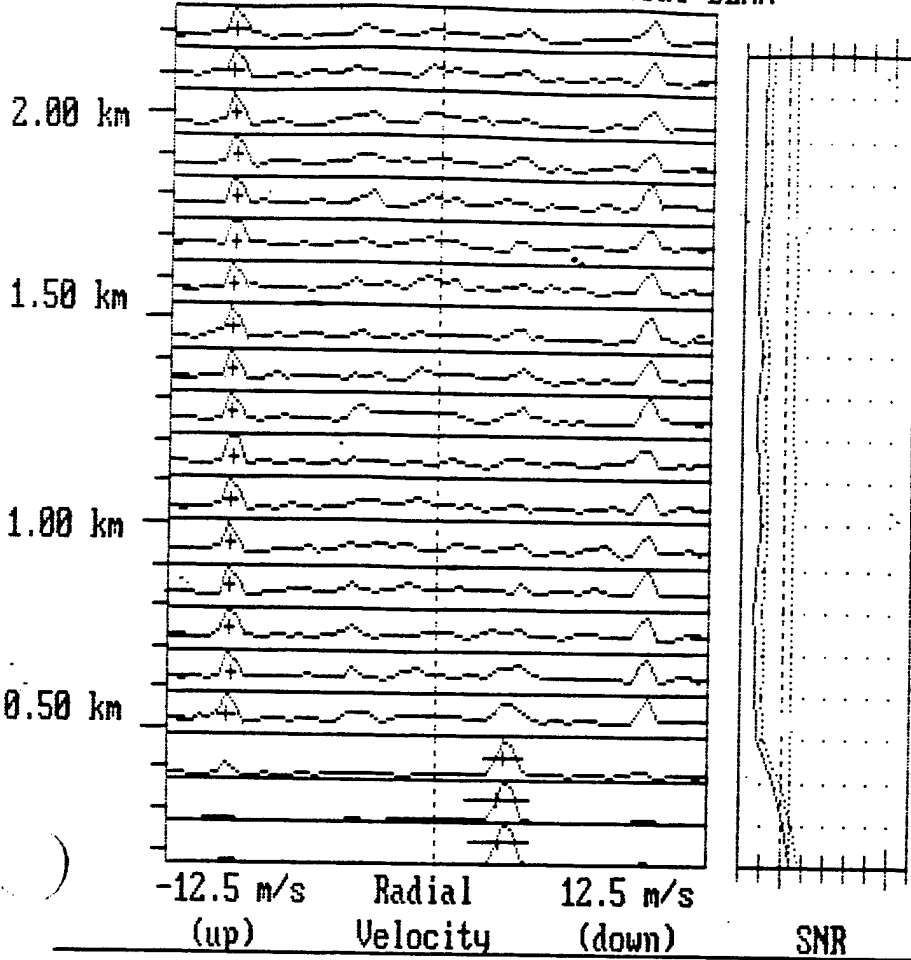

IPP: 20.000 μ sec
PW: 1.400
NCI: 324
NSP: 60
NHTS: 20
DLY: 2.000
SPAC: 0.700
NPTS: 64

CLUTTER RM @ 18 HTS
WINDOW+, DCFIL+
SPEC AVG: MEAN

LINEAR SPECTRA
NORMALIZED
GAIN = 1.000000
DISK WRITE: 3.4% FULL
HTS: ALL, PTS: ALL

WSMR System
ARL Receiver
50 Ω Terminator on Receiver
generator power

" 60 Hz Test "

DENVER WIT, LAP-3000, POP4
1998 Jun 22 Mon 11:20:35 LT Day 173
AZ: 357 EL: 90.0 X Vertical BEAM

CONSENSING FOR 30 MIN:
2 1 1 1 1

H^T AGL

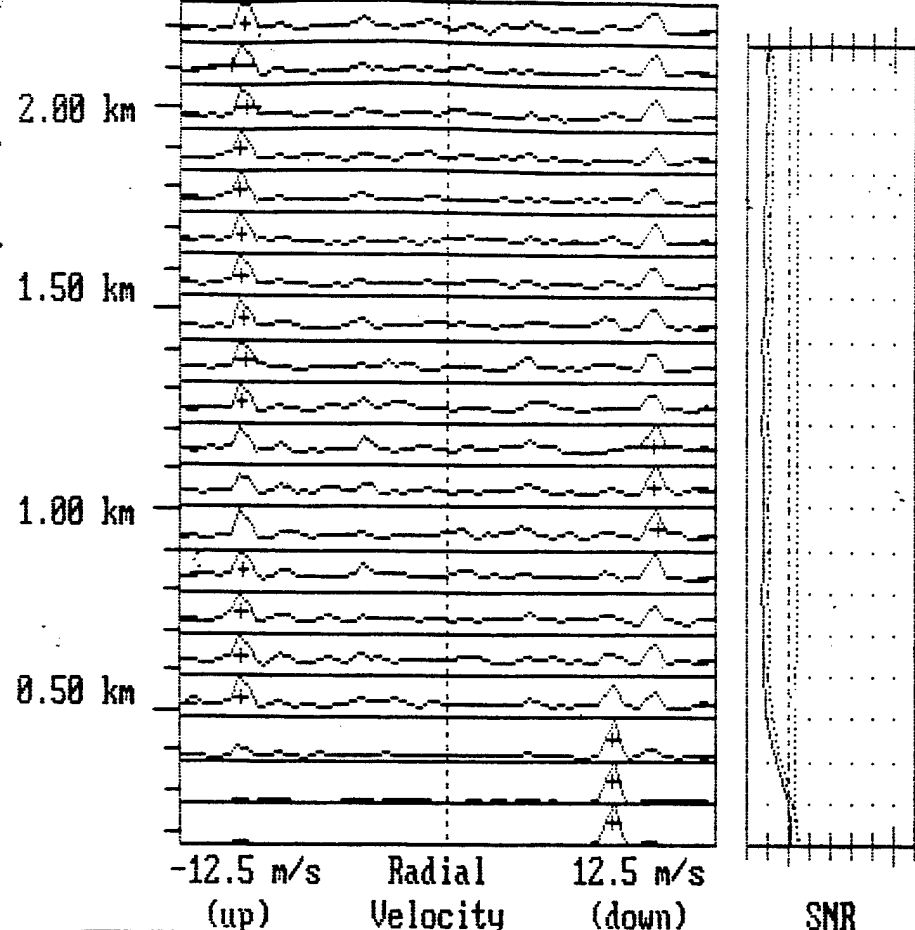

IPP: 20.000 μ sec
PW: 1.400
NCI: 324
NSP: 60
NHTS: 20
DLY: 2.000
SPAC: 0.700
NPTS: 64

CLUTTER RM @ 18 HTS
WINDOW+, DCFIL+
SPEC AVG: MEAN

LINEAR SPECTRA
NORMALIZED
GAIN = 1.000000
DISK WRITE: 3.4% FULL
HTS: ALL, PTS: ALL

*WSMR system w/ ARL Receiver
50 Ω terminator or RC
generator power*

"60 Hz Test"

DENVER WIT, LAP-3000, POP4
1998 Jun 22 Mon 11:28:20 LT Day 173
AZ: 357 EL: 90.0 X Vertical BEAM

CONSENSING FOR 30 MIN:
5 4 4 4 4

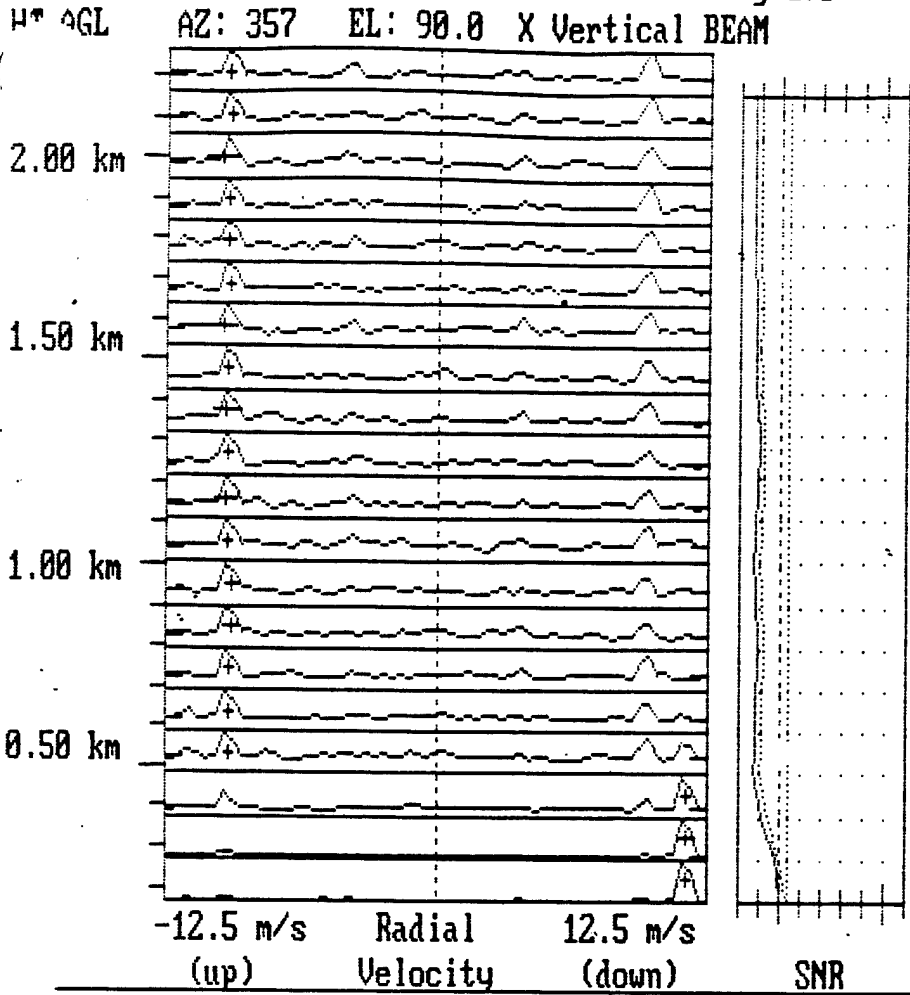

IPP: 20.000 µsec
PW: 1.400
NCI: 324
NSP: 60
NHTS: 20
DLY: 2.000
SPAC: 0.700
NPTS: 64

CLUTTER RM @ 18 HTS
WINDOW+, DCFIL+
SPEC AVG: MEAN

LINEAR SPECTRA
NORMALIZED
GAIN = 1.000000
DISK WRITE: 3.4% FULL
HTS: ALL, PTS: ALL

*WSMR system w/ARL Receiver
50 Ω Terminator on RC-in
generate power*

"60 Hz Test"

DENVER WIT, LAP-3000, POP4
1998 Jun 22 Mon 11:32:13 LT Day 173
AZ: 177 EL: 66.4 South BEAM

CONSENSING FOR 30 MIN:
1 1 1 1 0

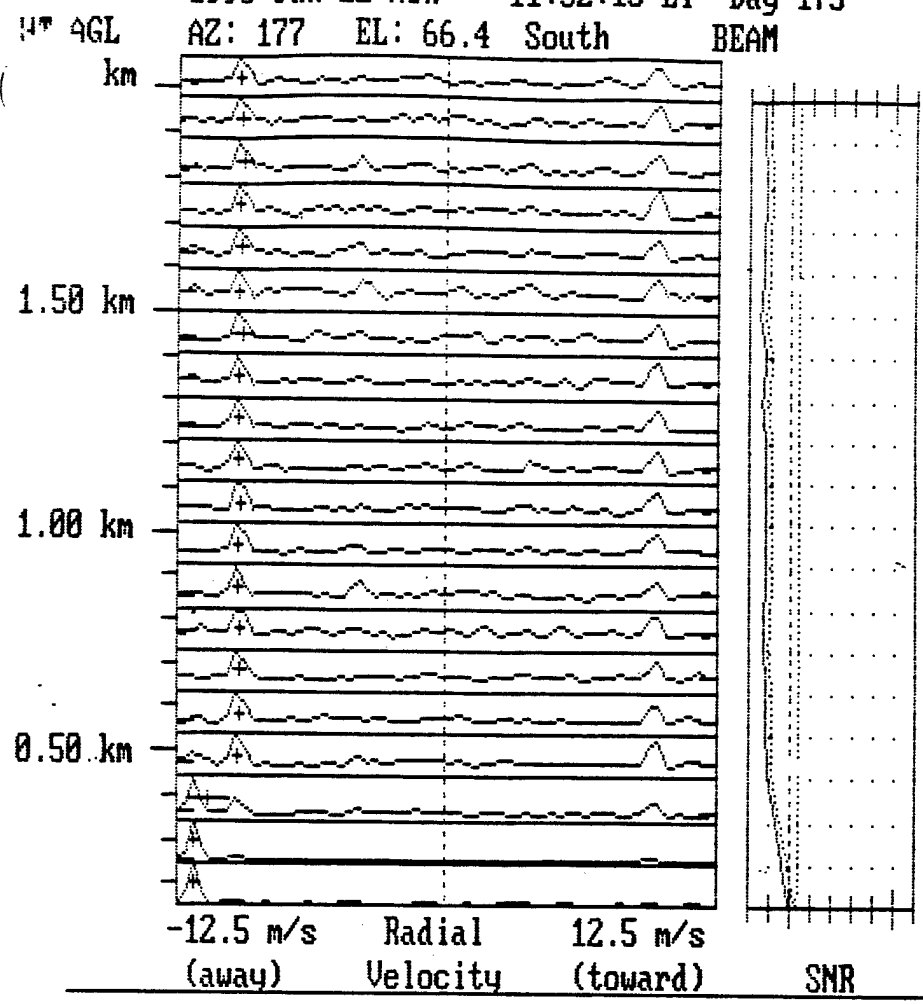

IPP: 20.000 μ sec
PW: 1.400
NCI: 324
NSP: 60
NHTS: 20
DLY: 2.000
SPAC: 0.700
NPTS: 64

CLUTTER RM @ 20 HTS
WINDOW+, DCFIL+
SPEC AVG: MEAN

LINEAR SPECTRA
NORMALIZED
GAIN = 1.000000
DISK WRITE: 3.4% FULL
HTS: ALL,PTS: ALL

*WSMR system w/ARL Receiver
50 Ω Terminator at RC-in
generator power*

"60 Hz Test"

DENVER WIT, LAP-3000, POP4
1998 Jun 22 Mon 11:54:53 LT Day 173
AZ: 87 EL: 66.4 East BEAM

CONSENSING FOR 30 MIN:
10 10 10 10 10

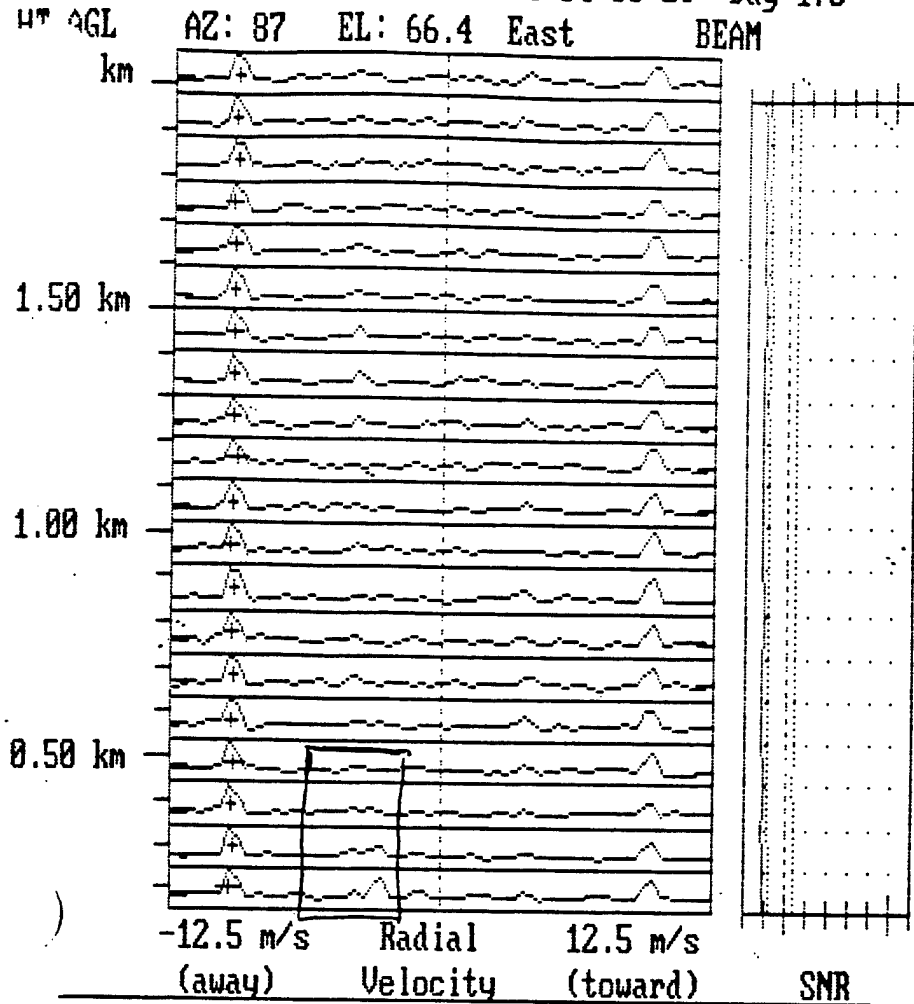

IPP: 20.000 μ sec
PW: 1.400
NCI: 324
NSP: 60
NHTS: 20
DLY: 2.000
SPAC: 0.700
NPTS: 64

CLUTTER RM @ 20 HTS
WINDOW+, DCFIL+
SPEC AVG: MEAN

LINEAR SPECTRA
NORMALIZED
GAIN = 1.000000
DISK WRITE: 3.4% FULL
HTS: ALL, PTS: ALL

*WSMR system w/ARL Receiver
50 Ω Terminator on Receiver - in
Generator power*

"60 Hz Test"

*> migrating peak in gates 1-3 still present;
 ± 8.8 m/s peaks are now evident in 1-3 gates.*

DENVER W11, LAP-3800, POP4
1998 Jun 22 Mon 12:28:43 LT Day 173
AZ: 267 EL: 66.4 West BEAM

CONSENSING FOR 30 MIN:
1 1 1 0 0

H^T AGL

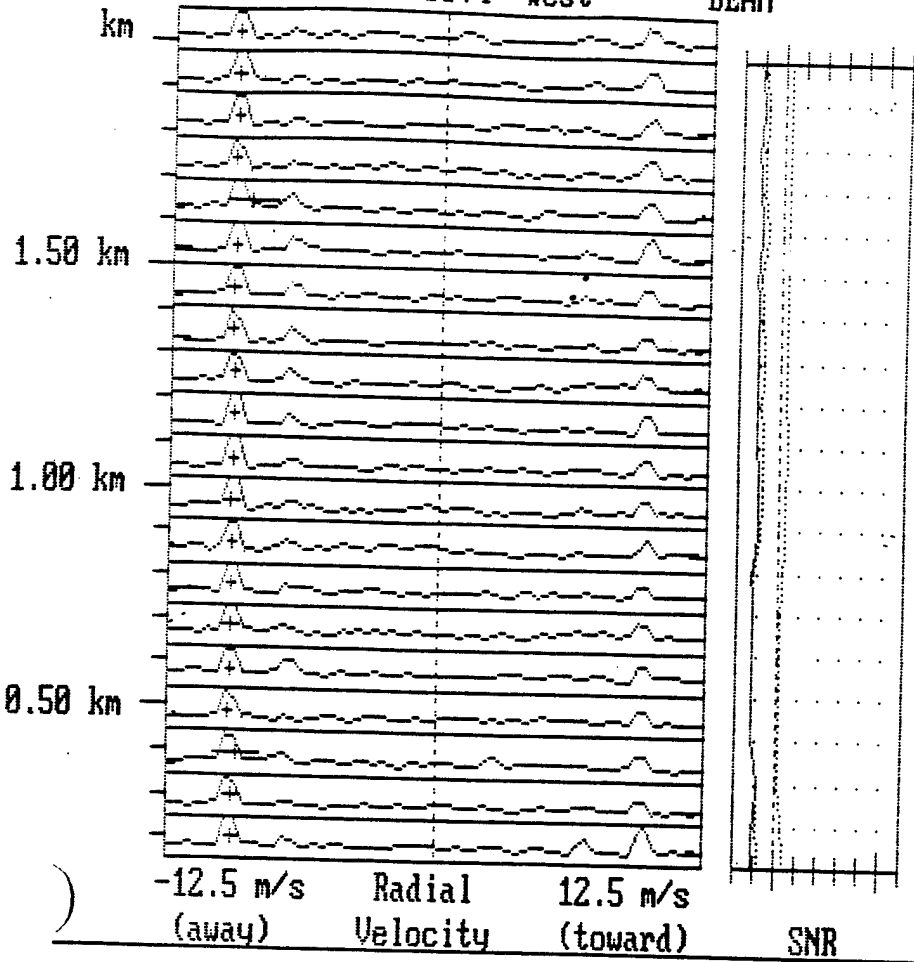

IPP: 20.000 μ sec
PW: 1.400
NCI: 324
NSP: 60
NHTS: 20
DLY: 2.000
SPAC: 0.700
NPTS: 64

CLUTTER RM @ 20 HTS
WINDOW+, DCFIL+
SPEC AVG: MEAN

LINEAR SPECTRA
NORMALIZED
GAIN = 1.000000
DISK WRITE: 3.4% FULL
HTS: ALL,PTS: ALL

WSMR system w/ARL Interface Box
50 Ω Terminator on RC-in
Generator Power

"60Hz Test"

± 8.8 m/s peaks

DENVER WIT, LAP-3000, POP4
1998 Jun 22 Mon 12:53:29 LT Day 173
AZ: 177 EL: 66.4 South BEAM

CONSENSING FOR 30 MIN:
10 10 10 10 9

H^T AGL

km

1.50 km

1.00 km

0.50 km

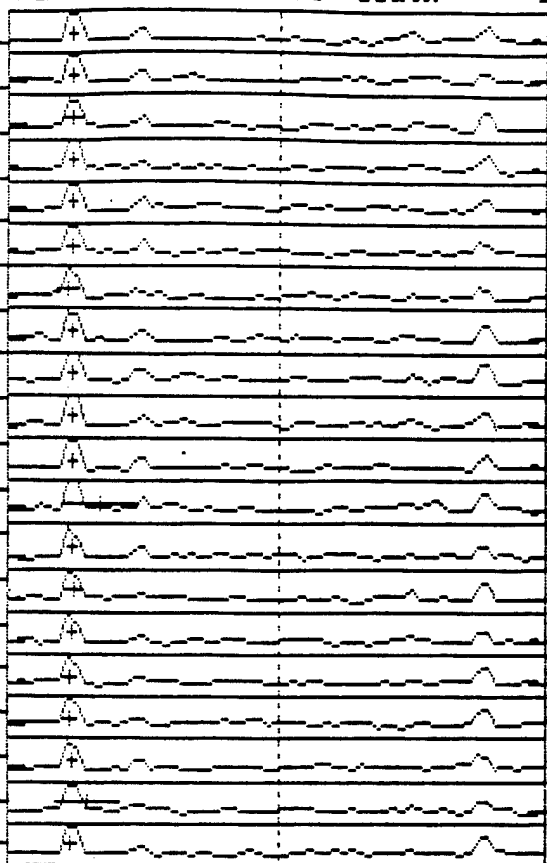

-12.5 m/s Radial 12.5 m/s
(away) Velocity (toward)

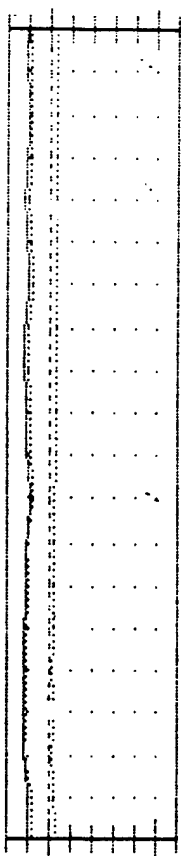

SNR

IPP: 20.000 μ sec
PW: 1.400
NCI: 324
NSP: 60
MHTS: 20
DLY: 2.000
SPAC: 0.700
NPTS: 64

CLUTTER RM @ 20 HTS
WINDOW+, DCFIL+
SPEC AVG: MEAN

LINEAR SPECTRA
NORMALIZED
GAIN = 1.000000
DISK WRITE: 3.4% FULL
HTS: ALL, PTS: ALL

WSMR system w/ARL Interface Box
50 Ω Terminator on RC-in
Generator Power

"60 Hz Test"

± 8.8 m/s Peaks

DENVER WIT, LAP-3000, POP4
1998 Jun 22 Mon 12:57:08 LT Day 173
AZ: 357 EL: 90.0 X Vertical BEAM

CONSENSING FOR 30 MIN:
12 11 11 11 11

HT AGL

2.00 km

1.50 km

1.00 km

0.50 km

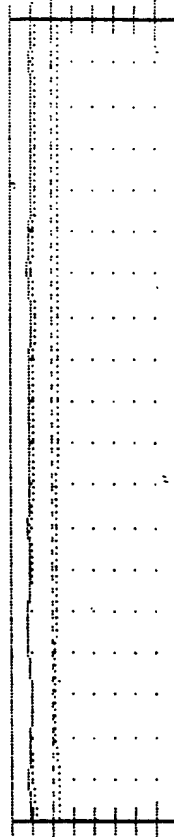
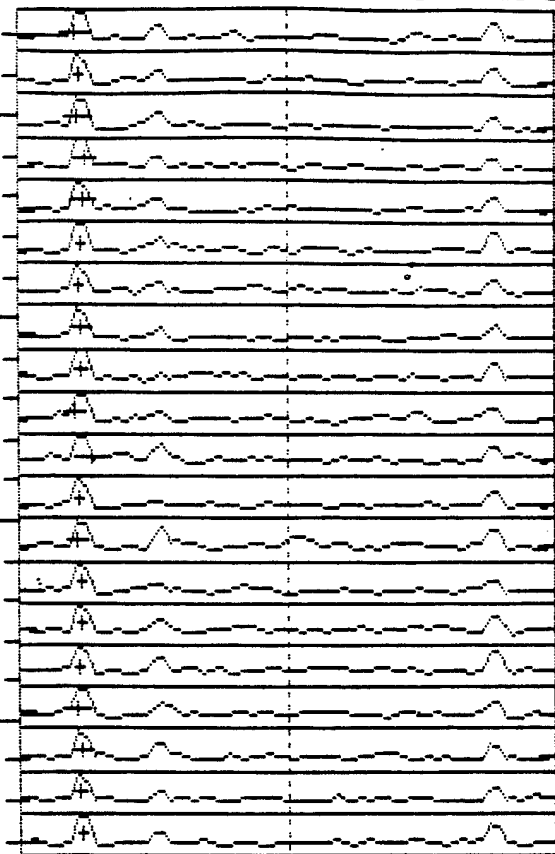

-12.5 m/s Radial 12.5 m/s
(up) Velocity (down)

SNR

IPP: 20.000 μ sec
PW: 1.400
NCI: 324
NSP: 60
NHTS: 20
DLY: 2.000
SPAC: 0.700
NPTS: 64

CLUTTER RM @ 18 HTS
WINDOW+, DCFIL+
SPEC AVG: MEAN

LINEAR SPECTRA
NORMALIZED
GAIN = 1.000000
DISK WRITE: 3.4% FULL
HTS: ALL,PTS: ALL

WSMR system w/ ^{ARL} Interface Box
50 Ω Terminator on RC-in
Generator Power

"60 Hz Test"

± 8.8 m/s Peaks

DENVER WIT, LAP-3000, POP4
1998 Jun 22 Mon 13:44:32 LT Day 173
AZ: 267 EL: 66.4 West BEAM

CONSENSING FOR 30 MIN:
5 5 5 4 4

μ* AGL
km

1.50 km

1.00 km

0.50 km

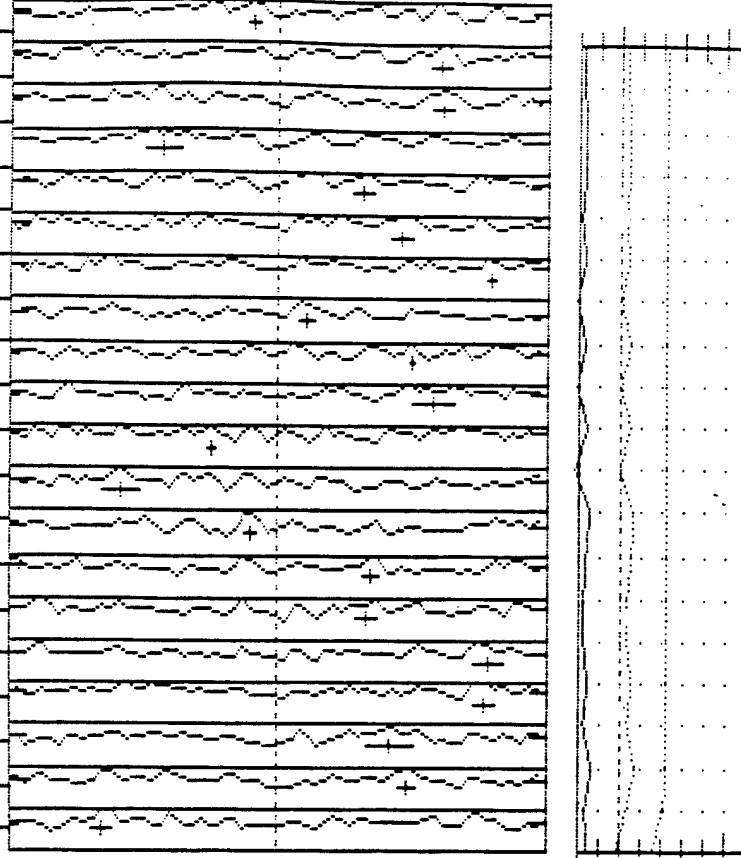

-12.5 m/s Radial 12.5 m/s
(away) Velocity (toward)

SNR

IPP: 20.000 μsec
PW: 1.400
NCI: 324
NSP: 60
NHTS: 20
DLY: 2.000
SPAC: 0.700
NPTS: 64

CLUTTER RM @ 20 HTS
WINDOW+, DCFIL+
SPEC AVG: MEAN

LINEAR SPECTRA
NORMALIZED
GAIN = 1.000000
DISK WRITE: 3.4% FULL
HTS: ALL,PTS: ALL

WSMR system w/ ARL Receiver only
50-Ω Terminator on final amplifier [before phase shifter + antenna]
generator power

Results: consistent w/ WSMR system only
all noise

DENVER WIT, LAP-3000, POP4
1998 Jun 22 Mon 13:48:37 LT Day 173
HT AGL AZ: 357 EL: 90.0 X Vertical BEAM

CONSENSING FOR 30 MIN:
7 6 6 6 6

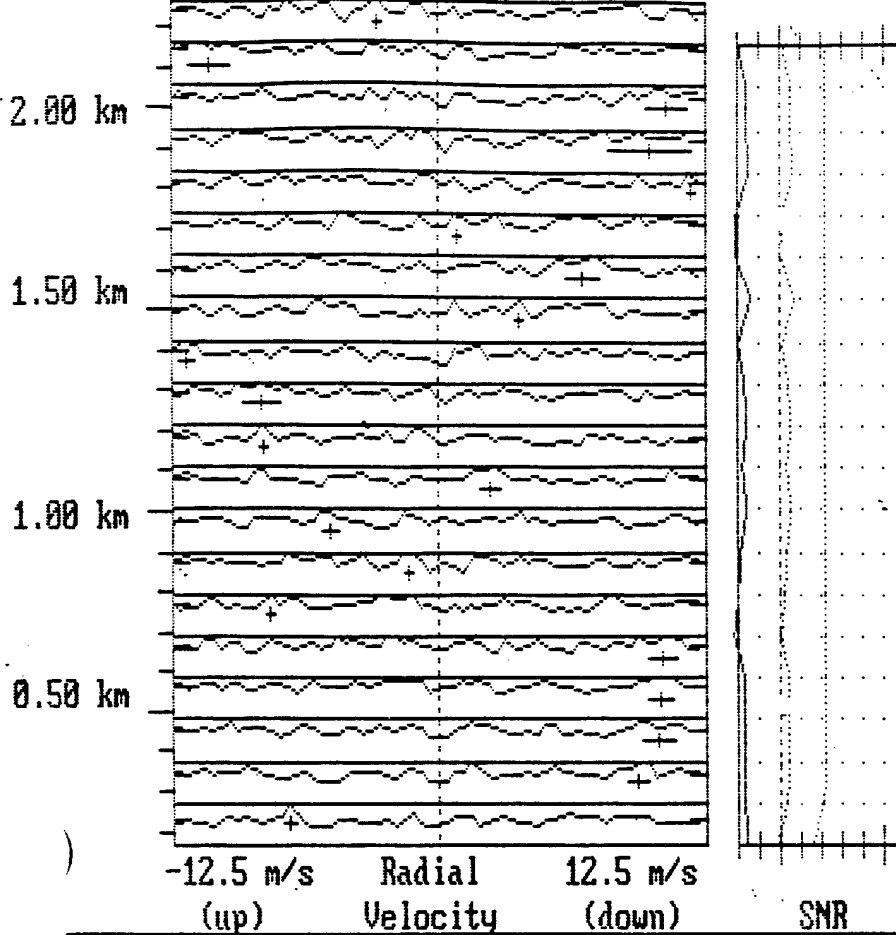

IPP: 20.000 µsec
PW: 1.400
NCI: 324
NSP: 60
NHTS: 20
DLY: 2.000
SPAC: 0.700
NPTS: 64

CLUTTER RM @ 18 HTS
WINDOW+, DCFIL+
SPEC AVG: MEAN

LINEAR SPECTRA
NORMALIZED
GAIN = 1.000000
DISK WRITE: 3.4% FULL
HTS: ALL, PTS: ALL

*WSMR system w/ARL Receiver only
TX off
50Ω terminator on final amplifier before phase shifter + antenna
generator power*

DENVER WIT, LAP-3000, POP4
 1998 Jun 22 Mon 14:03:59 LT Day 173
 AZ: 267 EL: 66.4 West BEAM

CONSENSING FOR 30 MIN:
 1 1 1 0 0

HT AGL

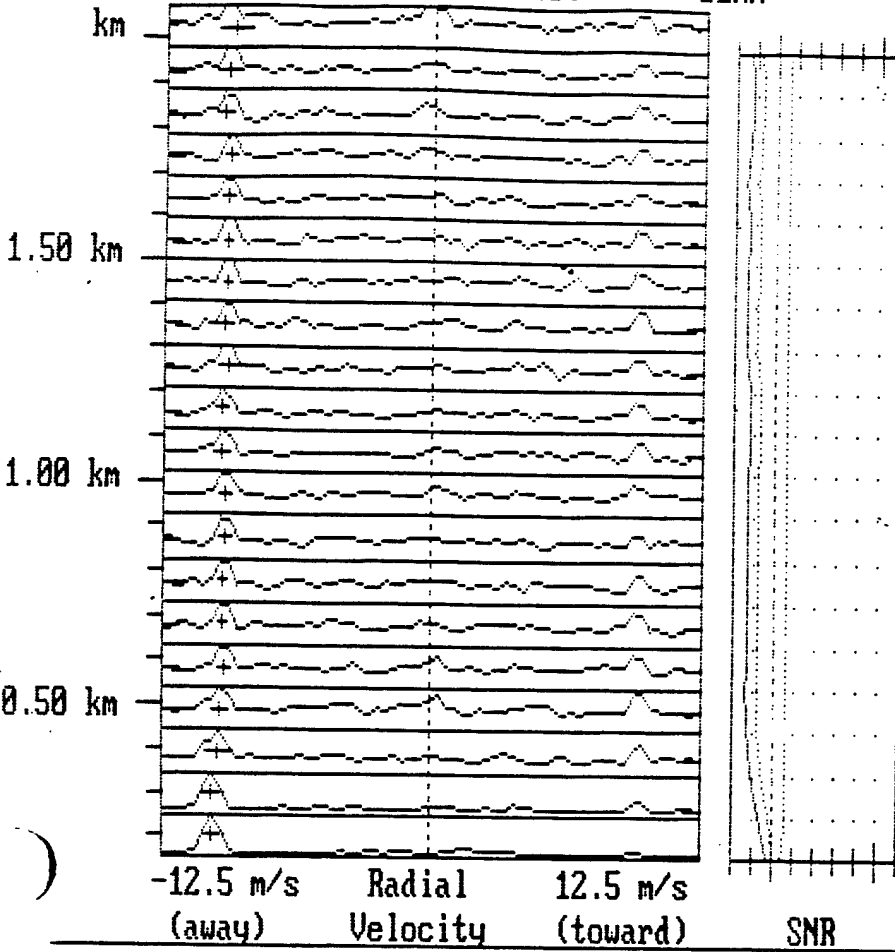

IPP: 20.000 μ sec
 PW: 1.400
 NCI: 324
 NSP: 60
 NHTS: 20
 DLY: 2.000
 SPAC: 0.700
 NPTS: 64

CLUTTER RM @ 20 HTS
 WINDOW+, DCFIL+
 SPEC AUG: MEAN

LINEAR SPECTRA
 NORMALIZED
 GA-Y = 1.000000
 DISK WRITE: 3.4% FULL
 HTS: ALL, PTS: ALL

WSMR system w/ ARL-Receiver + ARL-PreAmp

generator power

Tx off

50 Ω Terminator on ARL-PreAmp

[note: ± 8.8 m/s peaks \Rightarrow these should all be noise.]

1067

DENVER WIT, LAP-3000, POP4
1998 Jun 22 Mon 14:06:13 LT Day 173
AZ: 357 EL: 66.4 North BEAM

CONSENSING FOR 30 MIN:
2 2 1 1 1

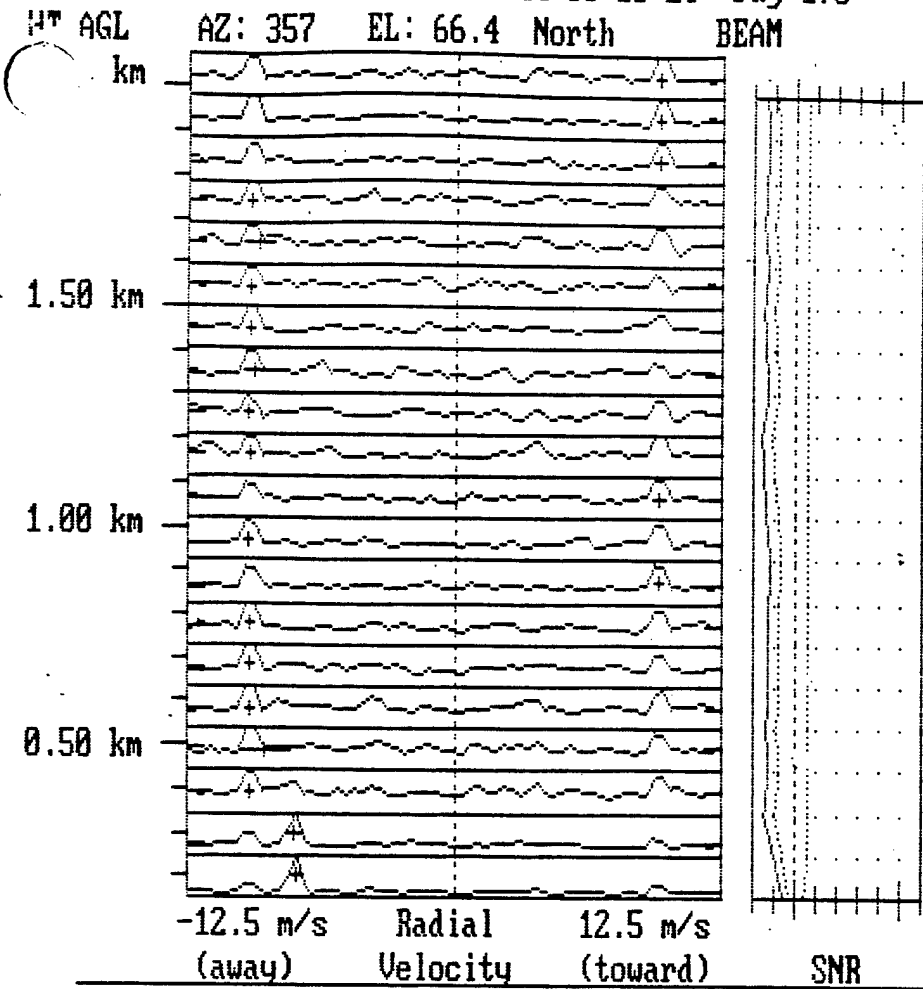

IPP: 20.000 μ sec
PW: 1.400
NCI: 324
NSP: 60
NHTS: 20
DLY: 2.000
SPAC: 0.700
NPTS: 64

CLUTTER RM @ 20 HTS
WINDOW+, DCFIL+
SPEC AVG: MEAN

LINEAR SPECTRA
NORMALIZED
GAIN = 1.000000
DISK WRITE: 3.4% FULL
HTS: ALL,PTS: ALL

*WSMR system w/ARL-Receiver, ARL-Pre Amp
generator power
50 Ω Terminator on ARL-Pre Amp*

DENVER WIT, LAP-3000, POP4
 1998 Jun 22 Mon 14:11:00 LT Day 173
 AZ: 87 EL: 66.4 East BEAM

CONSENSING FOR 30 MIN:
 3 3 3 3 3

(46)

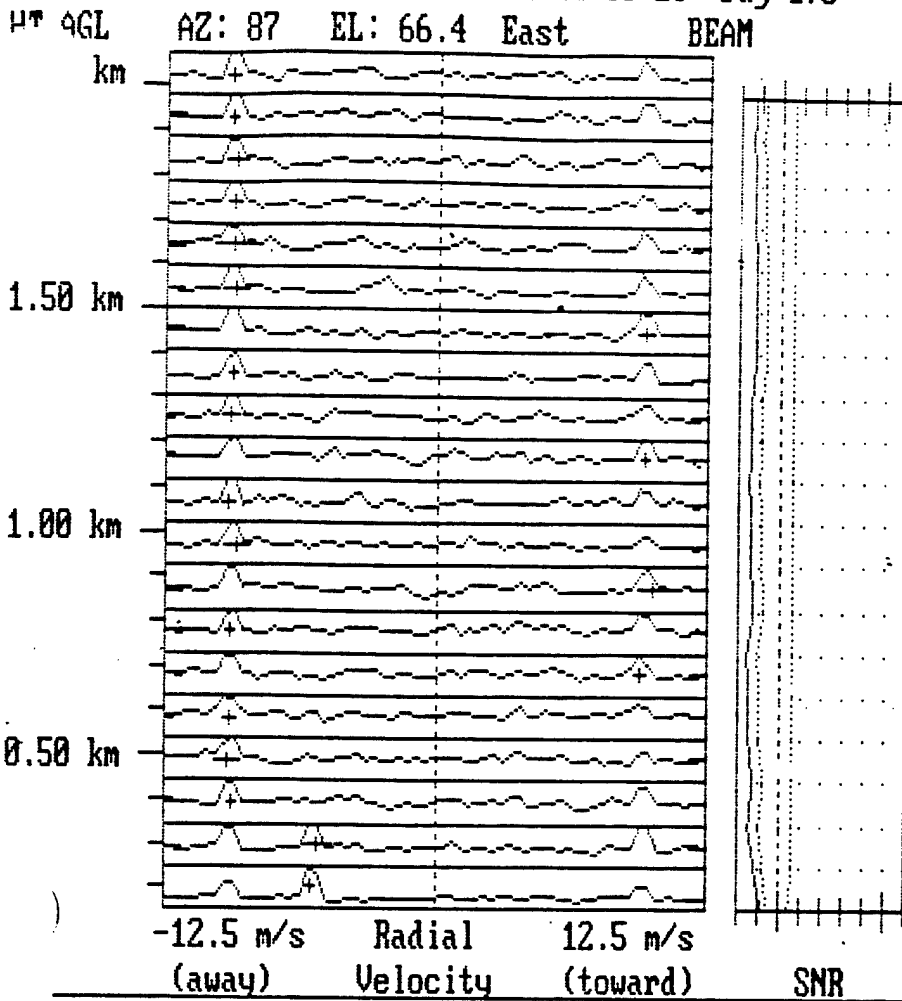

IPP: 20.000 μ sec
 PW: 1.400
 NCI: 324
 NSP: 60
 NHTS: 20
 DLY: 2.000
 SPAC: 0.700
 NPTS: 64

CLUTTER RM @ 20 HTS
 WINDOW+, DCFIL+
 SPEC AUG: MEAN

LINEAR SPECTRA
 NORMALIZED
 GAIN = 1.000000
 DISK WRITE: 3.4% FULL
 HTS: ALL, PTS: ALL

WSMR system w/ARL-Receiver and ARL-Pre-amp (before phase shift of antenna)

generator power

TX off

50 Ω Terminator on final amplifier (Pre-amp)

DENVER WIT, LAP-3000, POP4
1998 Jun 22 Mon 14:14:11 LT Day 173
AZ: 357 EL: 90.0 X Vertical BEAM

CONSENSING FOR 30 MIN:

5 4 4 4 4

Ht AGL

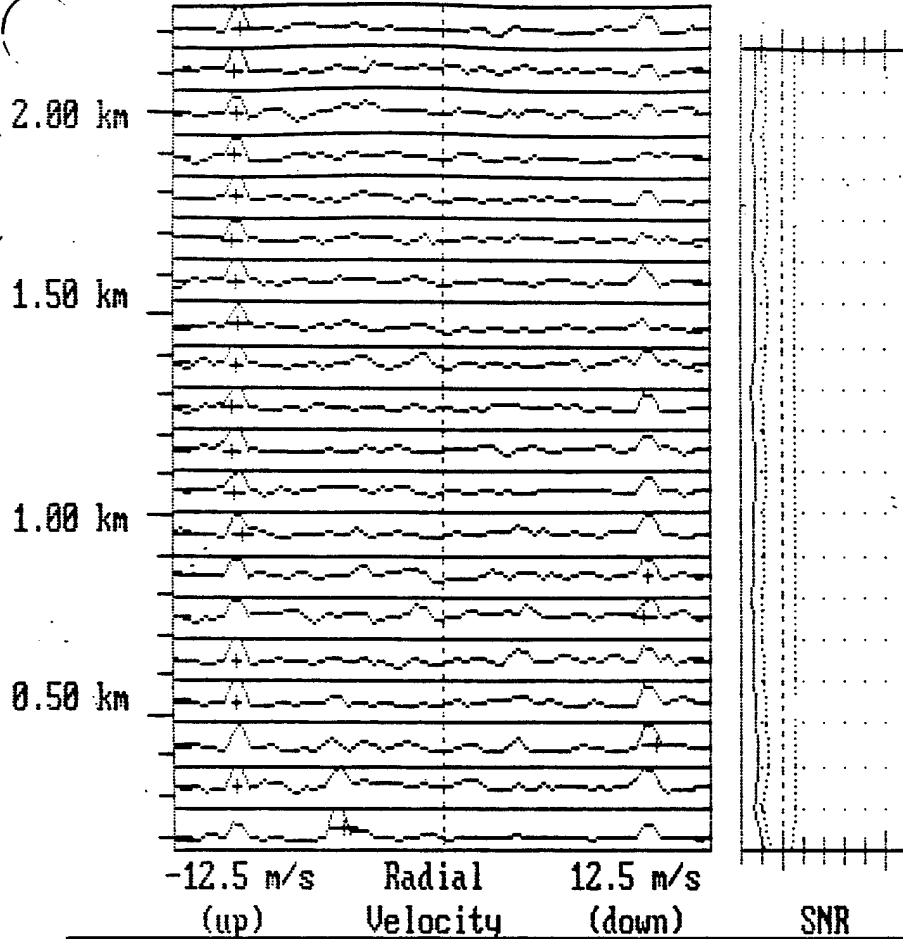

IPP: 20.000 µsec
PW: 1.400
NCI: 324
NSP: 60
NHTS: 20
DLY: 2.000
SPAC: 0.700
NPTS: 64

CLUTTER RM @ 18 HTS
WINDOW+, DCFIL+
SPEC AVG: MEAN

LINEAR SPECTRA
NORMALIZED
GAIN = 1.000000
DISK WRITE: 3.4% FULL
HTS: ALL, PTS: ALL

*WSMR system w/ARL-Receiver + ARL-De-Amp
generator power
TX off
50 Ω Terminator on De-amp*

48

DENVER WIT, LAP-3000, POP4
1998 Jun 22 Mon 14:20:43 LT Day 173
AZ: 357 EL: 66.4 North BEAM

CONSENSING FOR 30 MIN:
7 7 6 6 6

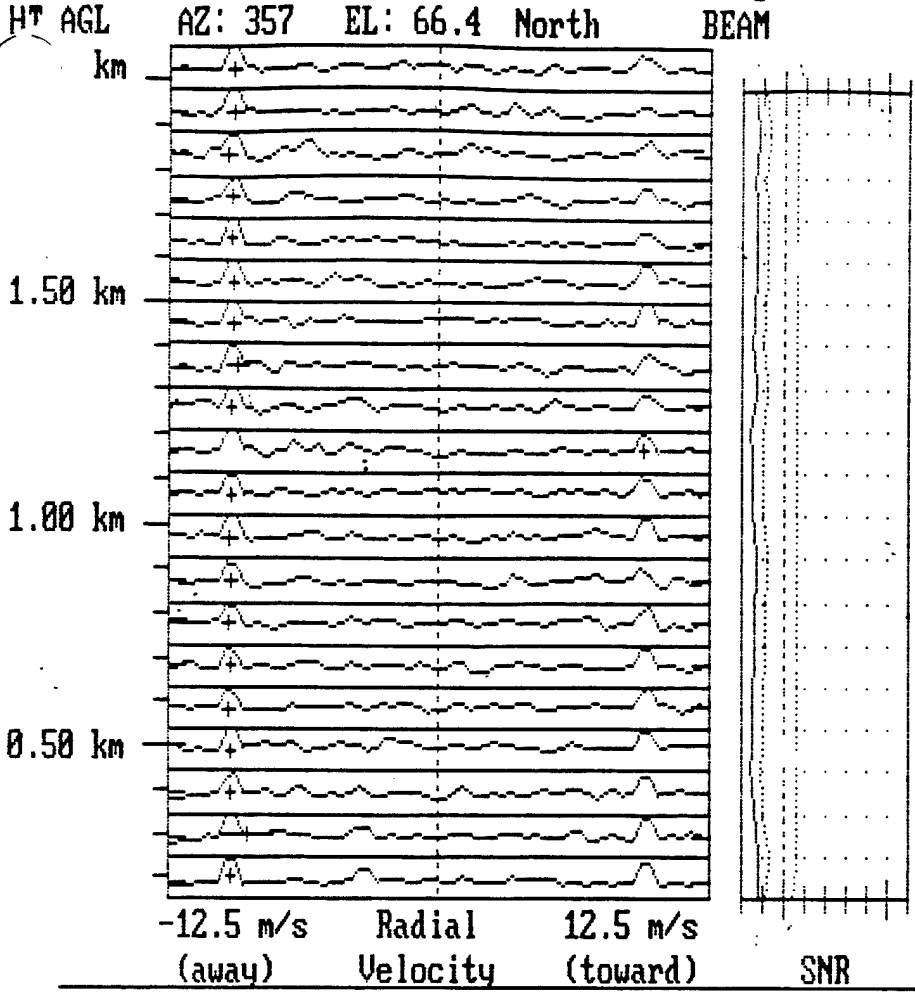

IPP: 20.000 μ sec
 PW: 1.400
 NCI: 324
 NSP: 60
 NHTS: 20
 DLY: 2.000
 SPAC: 0.700
 NPTS: 64

CLUTTER RM @ 20 HTS
 WINDOW+, DCFIL+
 SPEC AVG: MEAN

LINEAR SPECTRA
 NORMALIZED
 GAIN = 1.000000
 DISK WRITE: 3.4% FULL
 HTS: ALL, PTS: ALL

*System = WSMR w/ ARL-Receiver + ARL-Pe-Amp
 generate Power
 50 Ω terminate on Pe-Amp
 TX off*

DENVER WIT, LAP-3000, POP4
1998 Jun 22 Mon 14:26:54 LT Day 173
AZ: 267 EL: 66.4 West BEAM

CONSENSING FOR 30 MIN:
9 9 9 8 8

H^m AGL
km
1.50 km
1.00 km
0.50 km

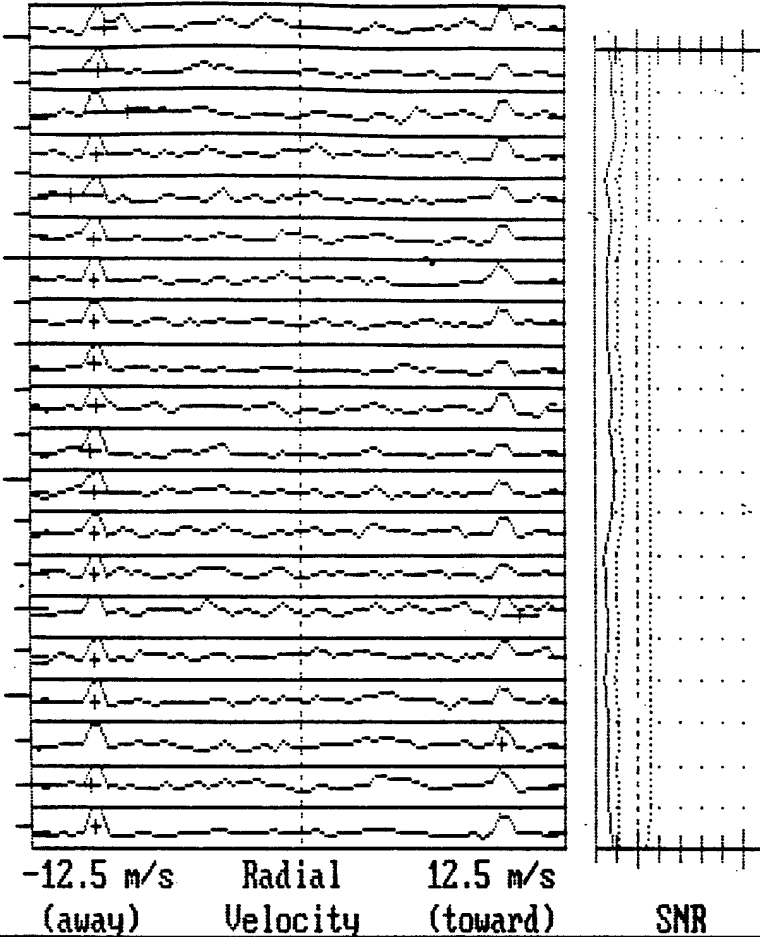

IPP: 20.000 μ sec
PW: 1.400
NCI: 324
NSP: 60
NHTS: 20
DLY: 2.000
SPAC: 0.700
NPTS: 64

CLUTTER RM @ 20 HTS
WINDOW+, DCFIL+
SPEC AVG: MEAN

LINEAR SPECTRA
NORMALIZED
GAIN = 1.000000
DISK WRITE: 3.4% FULL
HTS: ALL,PTS: ALL

*WSMR system w/ ARL-Receiver + ARL-PreAmp
generator Power
50 Ω Terminator on ARL-PreAmp
TX off*

DENVER WIT, LAP-3000, POP4
1998 Jun 22 Mon 14:31:52 LT Day 173
AZ: 177 EL: 66.4 South BEAM

CONSENSING FOR 30 MIN:
1 1 1 1 0

50

HT AGL
km
1.50 km
1.00 km
0.50 km

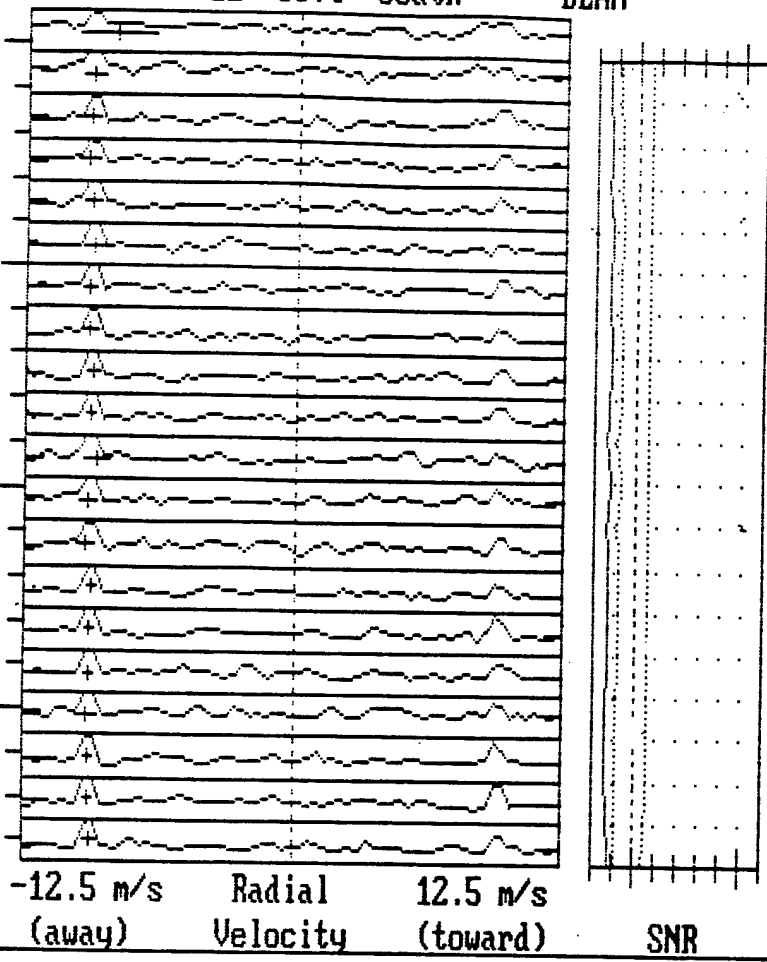

IPP: 20.000 μ sec
PW: 1.400
NCI: 324
NSP: 60
NHTS: 20
DLY: 2.000
SPAC: 0.700
NPTS: 64

CLUTTER RM @ 20 HTS
WINDOW+, DCFIL+
SPEC AVG: MEAN

LINEAR SPECTRA
NORMALIZED
GAIN = 1.000000
DISK WRITE: 3.4% FULL
HTS: ALL, PTS: ALL

WSMR System w/ ARL-Receiver + ARL-PeAmp (final amp)
generator power
TX off
50 Ω Terminator on final amplifier

DENVER WIT, LAP-3000, POP4
1998 Jun 22 Mon 14:44:02 LT Day 173
AZ: 357 EL: 90.0 X Vertical BEAM

CONSENSING FOR 30 MIN:
1 0 0 0 0

H^T AGL

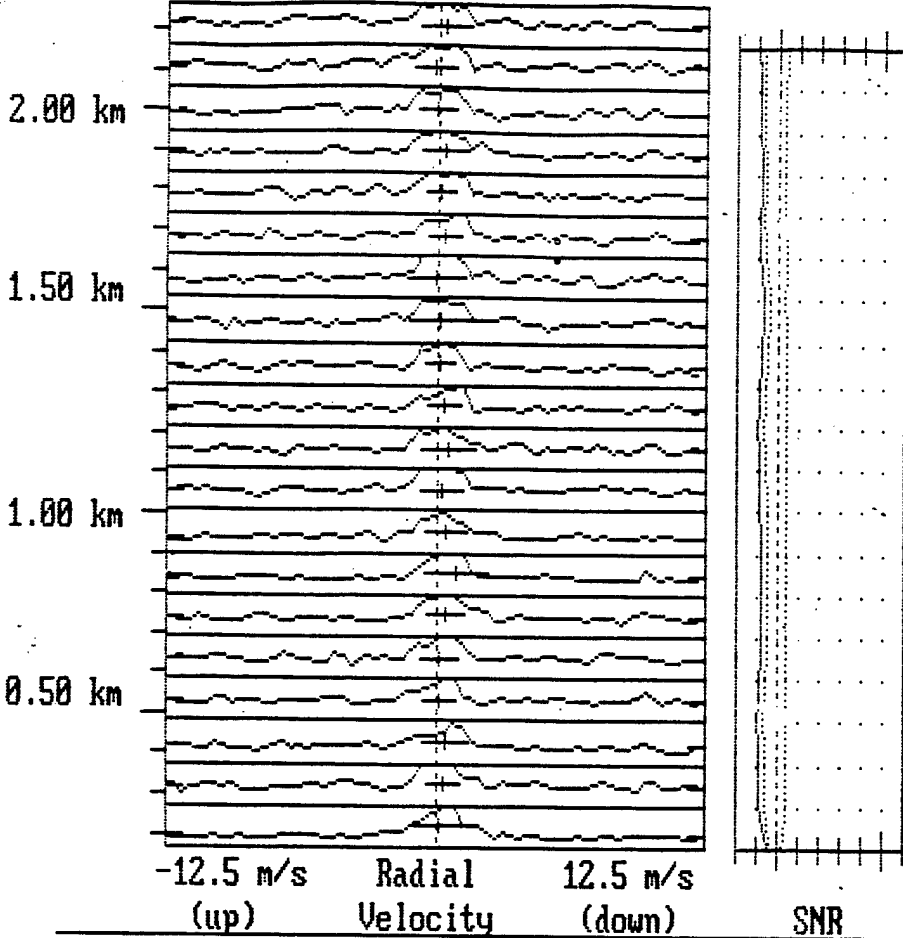

IPP: 20.000 µsec
PW: 1.400
NCI: 324
NSP: 60
NHTS: 20
DLY: 2.000
SPAC: 0.700
NPTS: 64

CLUTTER RM @ 18 HTS
WINDOW+, DCFIL+
SPEC AVG: MEAN

LINEAR SPECTRA
NORMALIZED
GAIN = 1.000000
DISK WRITE: 3.4% FULL
HTS: ALL,PTS: ALL

WSMR System w/ARL-Be Amp
generator power
50 Ω Terminator on ARL-Be-Amp
TX off
(very first screen)
note: center peak!

5a

DENVER WIT, LAP-3000, POP4
1998 Jun 22 Mon 14:45:48 LT Day 173
AZ: 177 EL: 66.4 South BEAM

CONSENSING FOR 30 MIN:
1 1 1 1 0

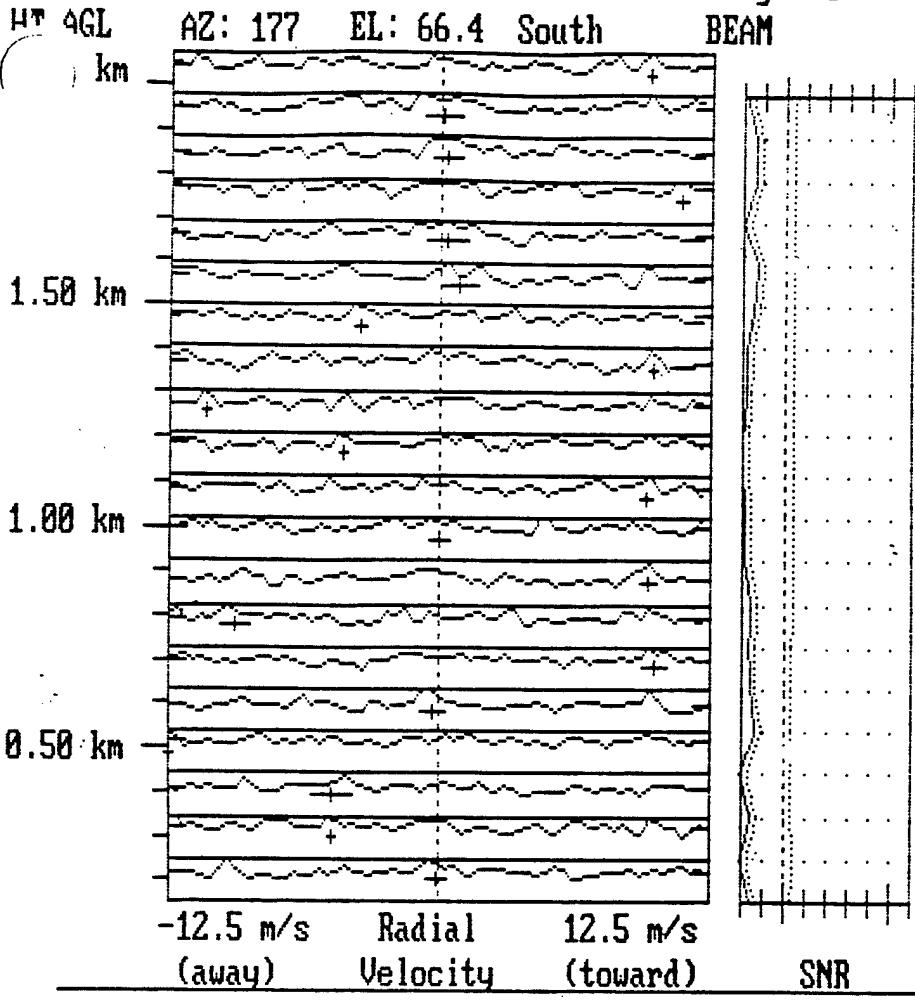

IPP: 20.000 μ sec
 PW: 1.400
 NCI: 324
 NSP: 60
 NHTS: 20
 DLY: 2.000
 SPAC: 0.700
 NPTS: 64

CLUTTER RM @ 20 HTS
 WINDOW+, DCFIL+
 SPEC AVG: MEAN

LINEAR SPECTRA
 NORMALIZED
 GAIN = 1.000000
 DISK WRITE: 3.4% FULL
 HTS: ALL, PTS: ALL

WSMR System w/ ARL-Pu-Amp

generator power
 TX off
 50 Ω Terminator on ARL-Pu-Amp

2 of 5

DENVER WIT, LAP-3000, POP4
1998 Jun 22 Mon 14:49:23 LT Day 173
AZ: 357 EL: 66.4 North BEAM

CONSENSING FOR 30 MIN:
1 1 0 0 0

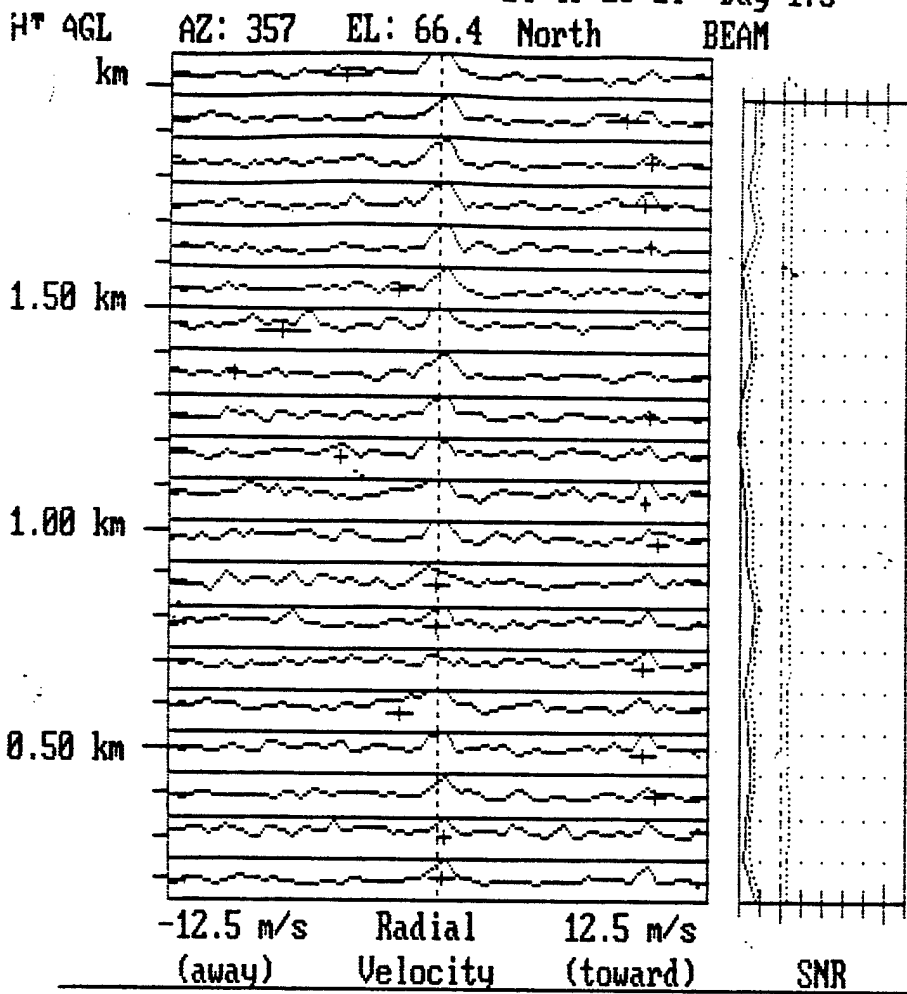

IPP: 20.000 μ sec
PW: 1.400
NCI: 324
NSP: 60
NHTS: 20
DLY: 2.000
SPAC: 0.700
NPTS: 64

CLUTTER RM @ 20 HTS
WINDOW+, DCFIL+
SPEC AVG: MEAN

LINEAR SPECTRA
NORMALIZED
GAIN = 1.000000
DISK WRITE: 3.4% FULL
HTS: ALL, PTS: ALL

WSMR System w/ARL-PuAmp
Generator power
50 Ω Terminate on ARL-Pu-Amp
Tx off

Note: center peak + +8.8 m/s peak

DENVER WIT, LAP-3000, POP4
1998 Jun 22 Mon 14:52:34 LT Day 173
AZ: 267 EL: 66.4 West BEAM

CONSENSING FOR 30 MIN:
2 2 2 1 1

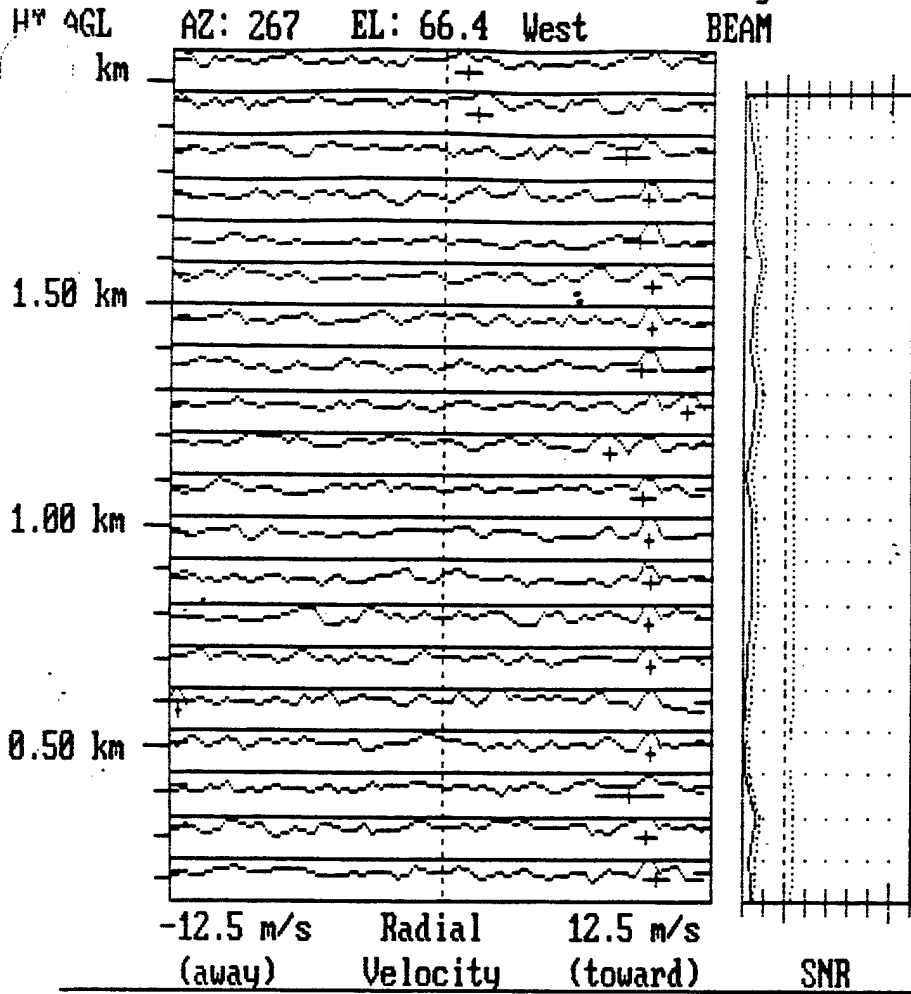

IPP: 20.000 μ sec
PW: 1.400
NCI: 324
NSP: 60
NHTS: 20
DLY: 2.000
SPAC: 0.700
NPTS: 64

CLUTTER RM @ 20 HTS
WINDOW+, DCFIL+
SPEC AVG: MEAN

LINEAR SPECTRA
NORMALIZED
GAIN = 1.000000
DISK WRITE: 3.4% FULL
HTS: ALL, PTS: ALL

WSMR System w/ ARL-BuAmp
Generator Power
50 Ω Terminator on ARL-BuAmp
Tx off

DENVER WIT, LAP-3000, POP4
1998 Jun 22 Mon 14:56:13 LT Day 173
AZ: 87 EL: 66.4 East BEAM

CONSENSING FOR 30 MIN:
3 3 3 3 3

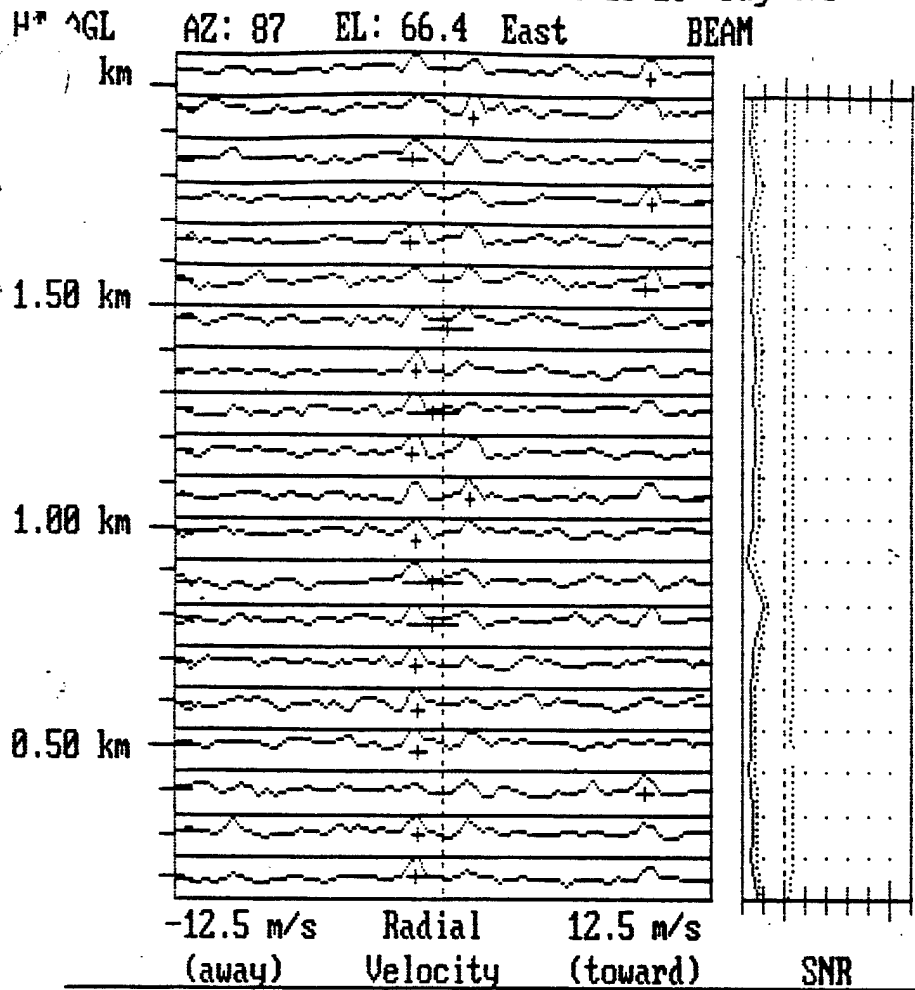

IPP: 20.000 μ sec
PW: 1.400
NCI: 324
NSP: 60
MHTS: 20
DLY: 2.000
SPAC: 0.700
NPTS: 64

CLUTTER RM @ 20 HTS
WINDOW+, DCFIL+
SPEC AVG: MEAN

LINEAR SPECTRA
NORMALIZED
GAIN = 1.000000
DISK WRITE: 3.4% FULL
HTS: ALL, PTS: ALL

WSMR system w/ ARL-Pre-amp
Generator power
50 Ω Terminator on ARL-PreAmp
TX off

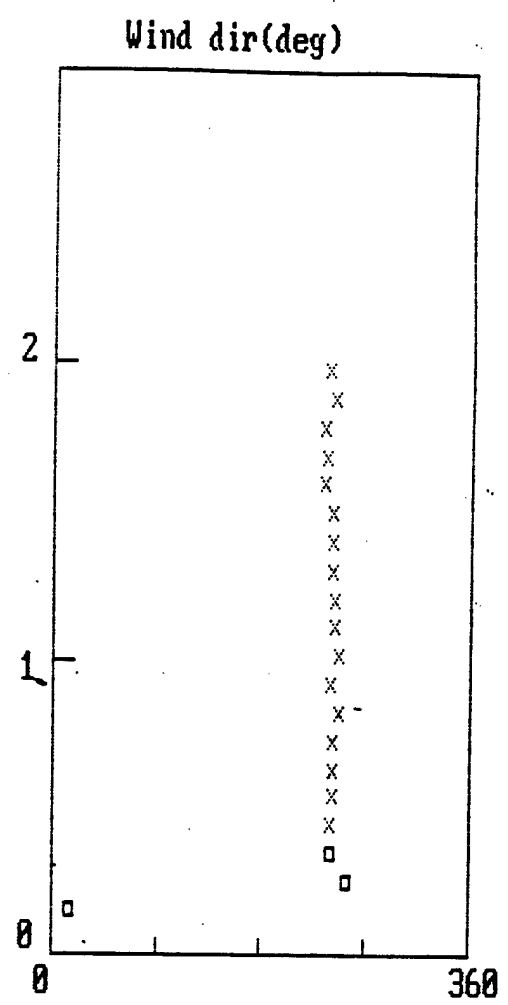
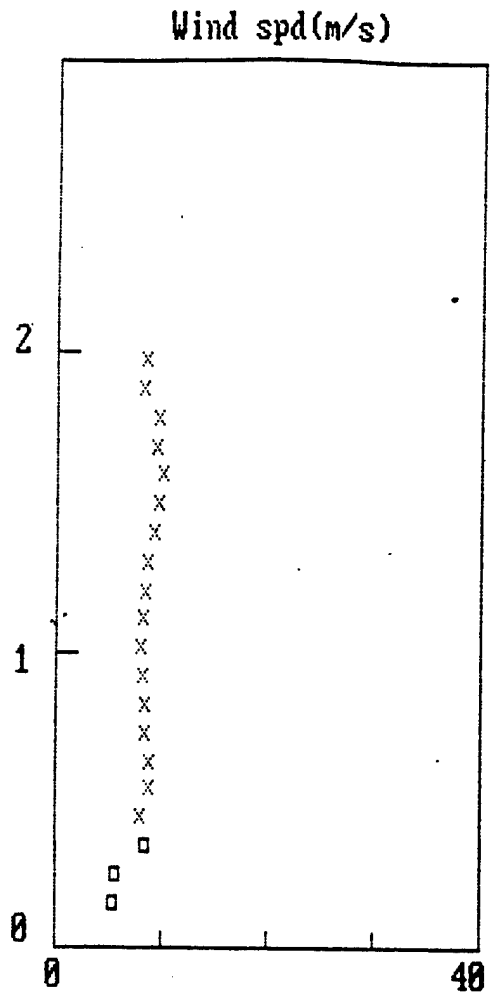

[wsmr system only]
[Vertical, N, W Beams]

Appendix B

Results from Elevating the Ground Clutter Removal Height of the Reconstructed 924-MHz Wind Profiling Radar System

System Parameters:

ARL01.PAR

98 July 9

[Day 190]

Radar Name: LAP-3000
Radar Code: 100
Operating Frequency: 924.00 MHz
Maximum TX Duty: 10.00 %
Maximum Pulse Length: 12 microseconds
Minimum IPP: 20 microseconds
Clock Cycle: 100 nanoseconds
PRE-T1R: 1000 nanoseconds
Post-T1R: 200 nanoseconds
PRE-Blank: 1000 nanoseconds
Post-Blank: 700 nanoseconds
Synch: 200 nanoseconds
Antenna Type: 5 beam phased

[Increased the MAX Ht for 8 Ju

Pulse Width System Delay
(nanosecs) (nanosecs)

400	1000
700	1100
1400	1200
2800	1400

Site Parameters:

Station Name: radar.par
Latitude: 40.05 Degrees North
Longitude: 115.03 Degrees West
Coordinated Universal Time Correction: 0.00 Hours
Site Altitude: 1265 Meters

Direction	Azimuth Degrees	Zenith Degrees	Axis	Direction Code
X Vertical	354	0.0	XV	0
Y Vertical	264	0.0	YV	1
North	354	15.5	X+	2
West	264	15.5	Y+	3
South	174	15.5	X-	4
East	84	15.5	Y-	5

Parameter Sets and Beam Sequencing:

Averaging Time in Minutes for the Wind Consensus: 15
RASS is always OFF.

Beam Sequencing Information

Seq #:	Ant Dir:	Num Reps:	Par Set #:
1	X Vertical	1	3
2	North	1	3
3	West	1	3
4	South	1	3
5	East	1	3

Parameter Set #'s:	1	2	3	4
IPP (microsecs):	23	23	59	20
Pulse Width (nanosecs):	400	700	2800	400
(nanosecs):	1600	1700	3300	1600
Spacing (nanosecs):	400	700	1400	400
# Gate Heights:	25	25	36	25
# Coherent Integrations:	340	340	180	10
# points in FFT:	64	64	64	64
# Spectra averaged:	42	42	42	20
# Code Bits:	0	0	0	0
TX Duty (%):	1.74	3.04	4.75	2.00
Dwell Time (secs):	24.03	24.03	32.00	2.74
Full Scale Velocity (m/s):	10.37	10.37	7.64	405.56
First Gate Height (m AGL):	90	90	285	90
Last Gate Height (m AGL):	1529	2608	7630	1529

Wind processing parameters:

Consensus Averaging window: Oblique modes = 2.00 m/s Vertical mode = 3.00 m/s
Percent required to pass consensus: Oblique modes = 60 % Vertical mode = 60 %
Max Height for clutter removal = 4500 meters.
The Vertical beam will be used in wind calculations.
The mean wind spectral averaging routine will be used.

Parameters:

Auto start disabled.
No hard copies generated.
Data height measurements are recorded as above ground level.
EGA monitor being used as display device.
Moment data will be written to c:\radar\data.
Consensus averaged data will be written to c:\radar\data directory.
LAP will run in real time mode.
LAP will not recalculate moments data from archived spectral data products.
Log data will be written to c:\radar\data\D95132a.LOG

radar.par, LAP-3000, POP4
1998 Jul 9 Thu 19:59:08 UT Day 190
AZ: 354 EL: 90.0 X Vertical BEAM

HT AGL

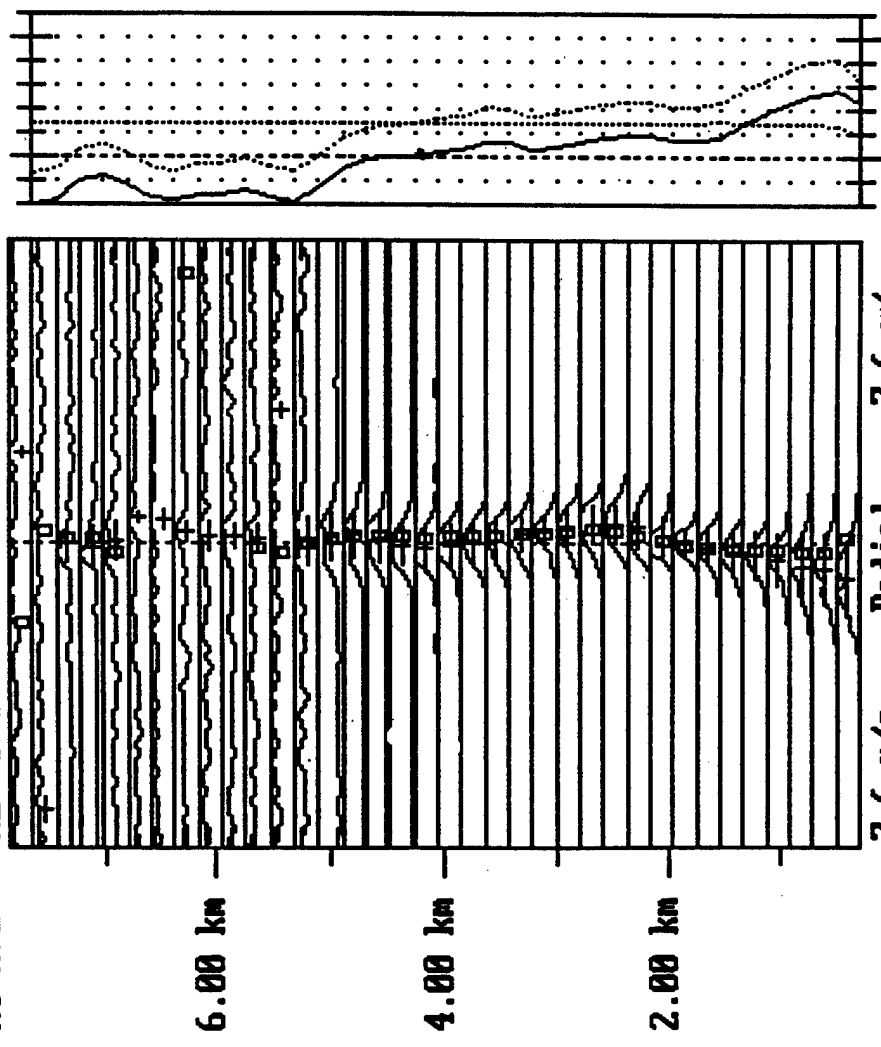

-7.6 m/s (up) Radial Velocity (down) 7.6 m/s

ALT+Q PAUSE ALT+X Abort Cns ALT+G Graph/Text F8 Display ALT+F3 New Disk

CONSENSING FOR 15 MIN:
6 5 5 5 5
IPP: 59.000 µsec
PW: 2.800
NCI: 180
NSP: 42
NHTS: 36
DLY: 3.300
SPAC: 1.400
NPTS: 64

CLUTTER RM @ 21 HTS
WINDOW+, DCFIL+
SPEC AVG: MEAN

LINEAR SPECTRA
NORMALIZED
GAIN = 1.000000
DISK WRITE: 32.1% FULL
HTS: ALL,PTS: ALL

radar.par, LAP-3000, POP4
1998 Jul 9 Thu 19:59:41 UT Day 190
AZ: 354 EL: 74.5 North BEAM

HT AGL 6.00 km 4.00 km 2.00 km

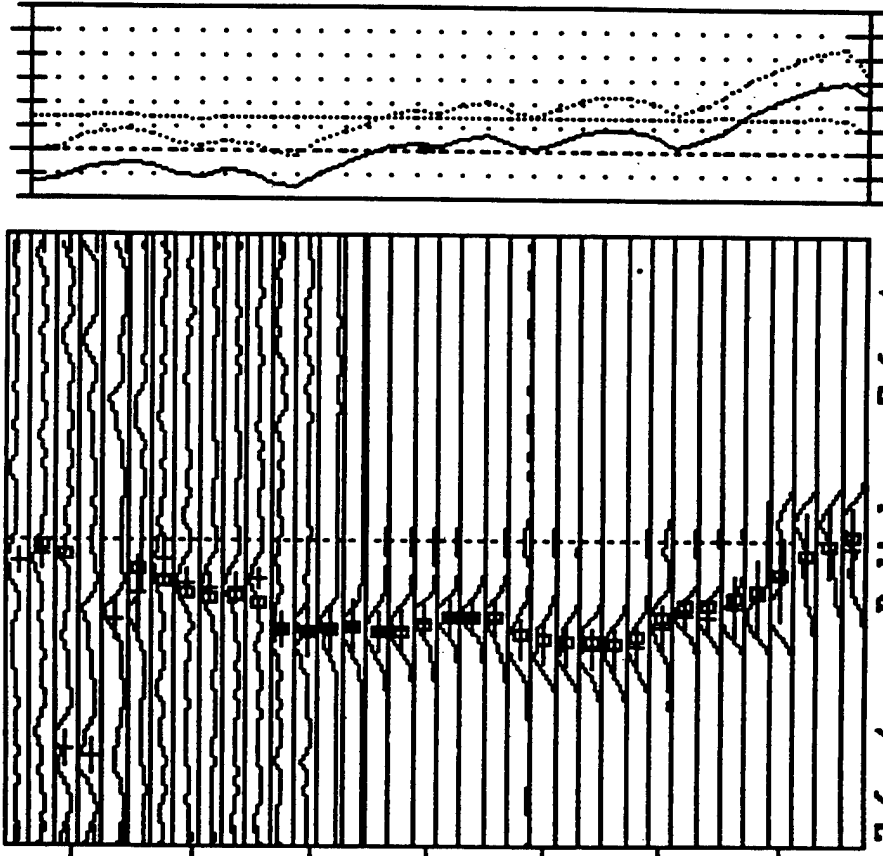

-7.6 m/s Radial Velocity (away) 7.6 m/s (toward)

SNR

ALT+Q PAUSE ALT+X Abort Cns ALT+G Graph/Text F8 Display ALT+F3 New Disk

IPP: 59.000 μ sec
PW: 2.800
NCI: 180
NSP: 42
NHTS: 36
DLX: 3.300
SPAC: 1.400
NPTS: 64

CLUTTER RM @ 21 HTS
WINDOW+, DCFIL+
SPEC AVG: MEAN

LINEAR SPECTRA
NORMALIZED

GAIN = 1.000000

DISK WRITE: 32.1% FULL

HTS: ALL,PTS: ALL

radar.par, LAP-3000, POP4
 1998 Jul 9 Thu 20:00:20 UT Day 190
 AZ: 264 EL: 74.5 West BEAM

HT AGL

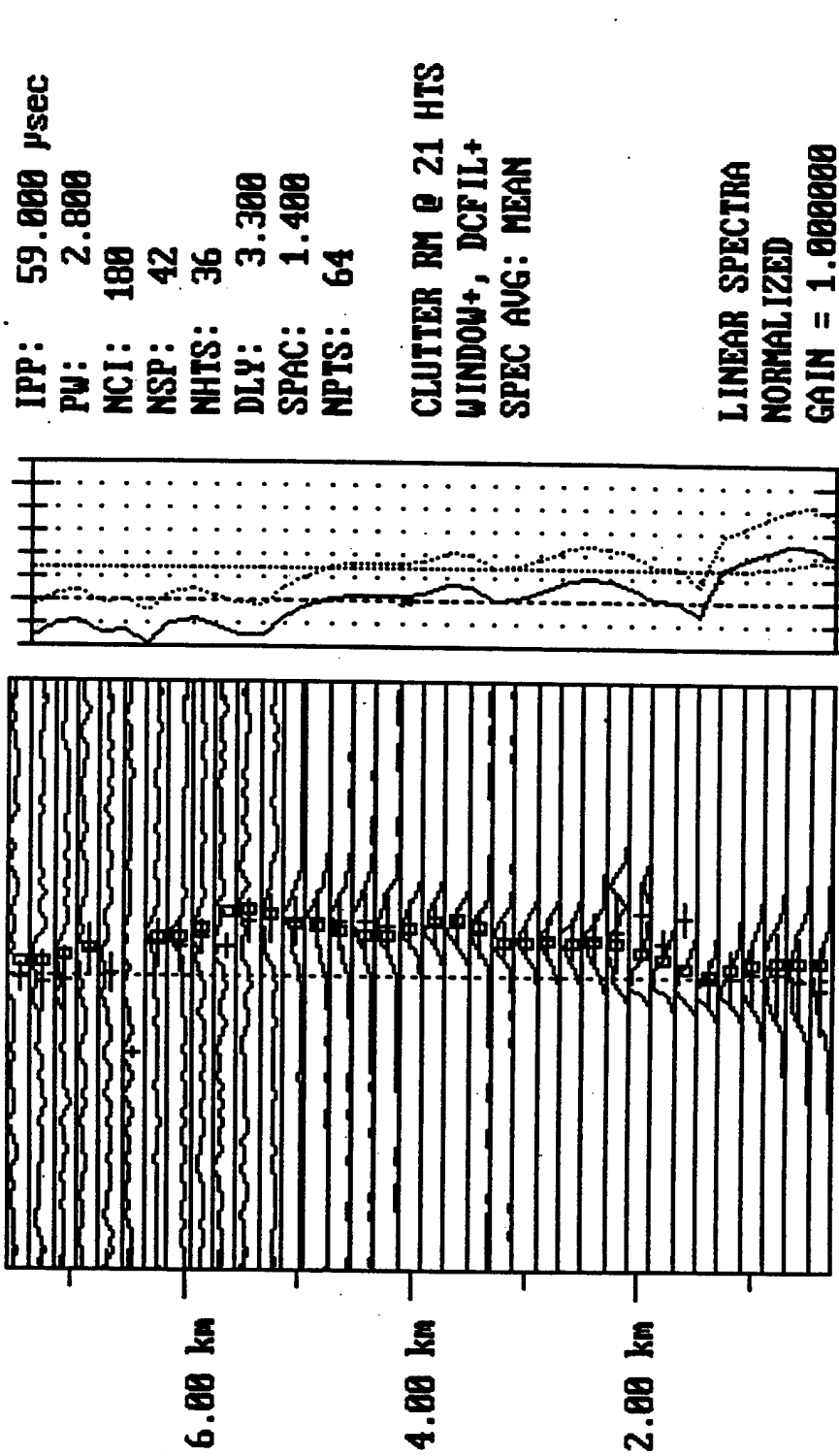

-7.6 m/s Radial Velocity (away) (toward) SNR
 7.6 m/s

CONSENSING FOR 15 MIN:
 0 0 1 0 0

IPP: 59.000 µsec
 PW: 2.800
 NCI: 180
 NSP: 42
 NHTS: 36
 DLY: 3.300
 SPAC: 1.400
 NPTS: 64

CLUTTER RM @ 21 HTS
 WINDOW+, DCFIL+
 SPEC AVG: MEAN

LINEAR SPECTRA
 NORMALIZED

GAIN = 1.000000
 DISK WRITE: 32.1% FULL
 HTS: ALL,PTS: ALL

ALT+Q PAUSE ALT+X Abort Cns ALT+G Graph/Text F8 Display ALT+F3 New Disk

(3)

radar.par, LAP-3000, POP4
1998 Jul 9 Thu 20:00:55 UT Day 190
AZ: 174 EL: 74.5 South BEAM

HT AGL

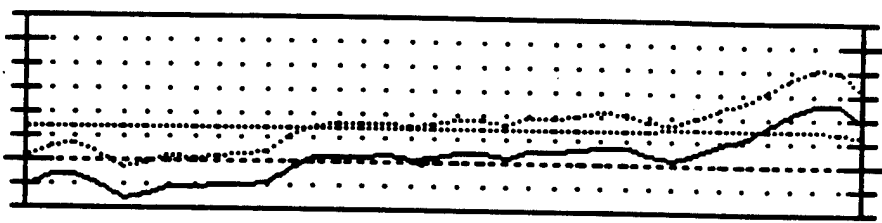
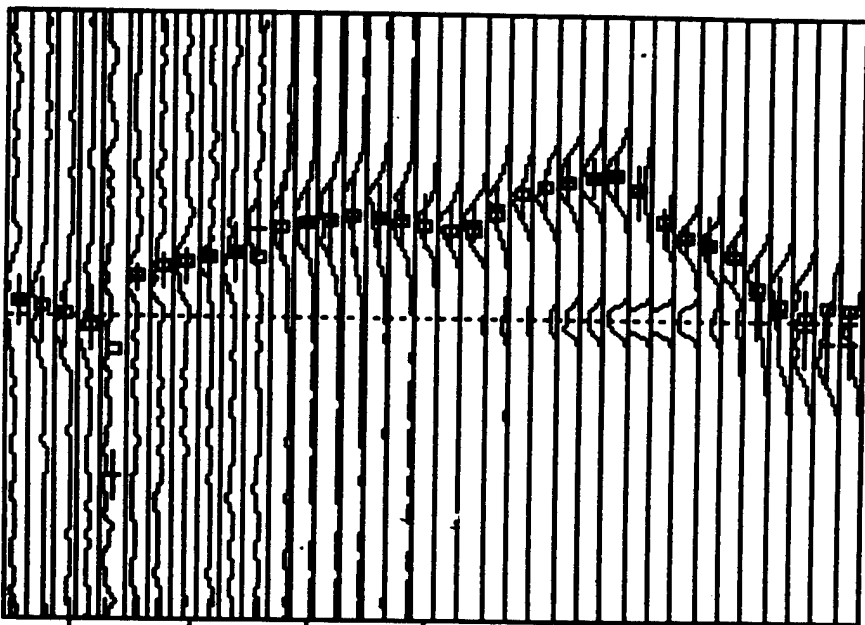

-7.6 m/s (away) Radial Velocity (toward) 7.6 m/s
SNR

ALT+Q PAUSE

ALT+X Abort Cns ALT+G Graph/Text F8 Display ALT+F3 New Disk

CONSENSING FOR 15 MIN:
0 0 1 1 0

IPP: 59.000 µsec
PW: 2.800
NCI: 100
NSP: 42
NHTS: 36
DLV: 3.300
SPAC: 1.400
NPTS: 64

CLUTTER RM @ 21 HTS
WINDOW+, DCFIL+
SPEC AVG: MEAN

LINEAR SPECTRA
NORMALIZED

GAIN = 1.000000

DISK WRITE: 32.2% FULL

HTS: ALL,PTS: ALL

radar.par, LAP-3000, POP4
 1998 Jul 9 Thu 20:01:29 UT Day 190
 AZ: 84 EL: 74.5 East BEAM

HT AGL

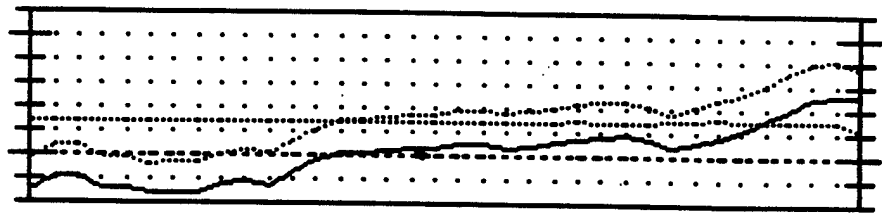
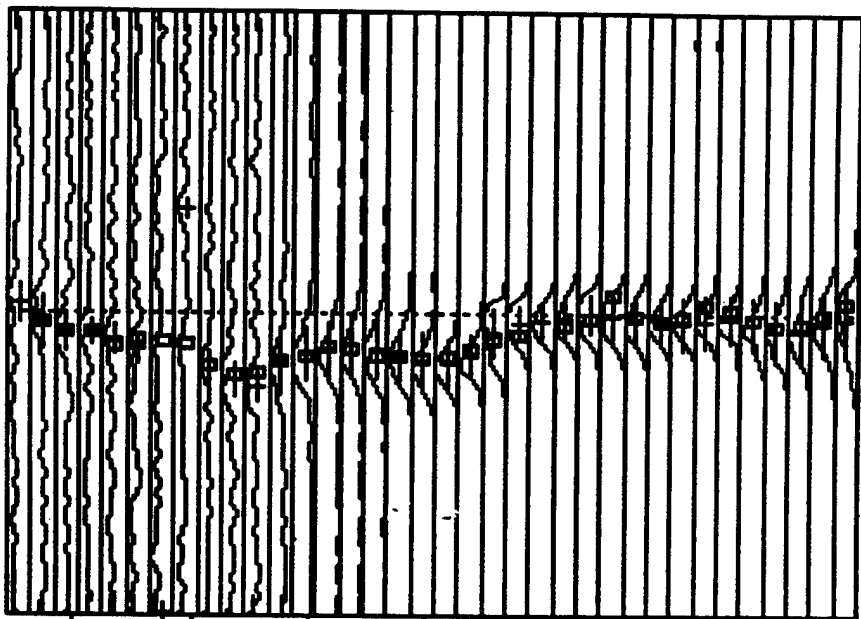

IPP: 59.000 μ sec
 PW: 2.800
 NCI: 180
 NSP: 42
 NHTS: 36
 DLY: 3.300
 SPAC: 1.400
 NPTS: 64

CLUTTER RM @ 21 HTS
 WINDOW+, DCFIL+
 SPEC AVG: MEAN

LINEAR SPECTRA
 NORMALIZED

GAIN = 1.000000
 DISK WRITE: 32.2% FULL
 HTS: ALL,PTS: ALL

-7.6 w/s Radial Velocity (away) (toward)
 SNR

ALT+Q PAUSE ALT+X Abort Cns ALT+G Graph/Text F8 Display ALT+F3 New Disk

radar.par, LAP-3000, POP4
1998 Jul 9 Thu 20:10:23 UT Day 190
AZ: 354 EL: 90.0 X Vertical BEAM

HT AGL

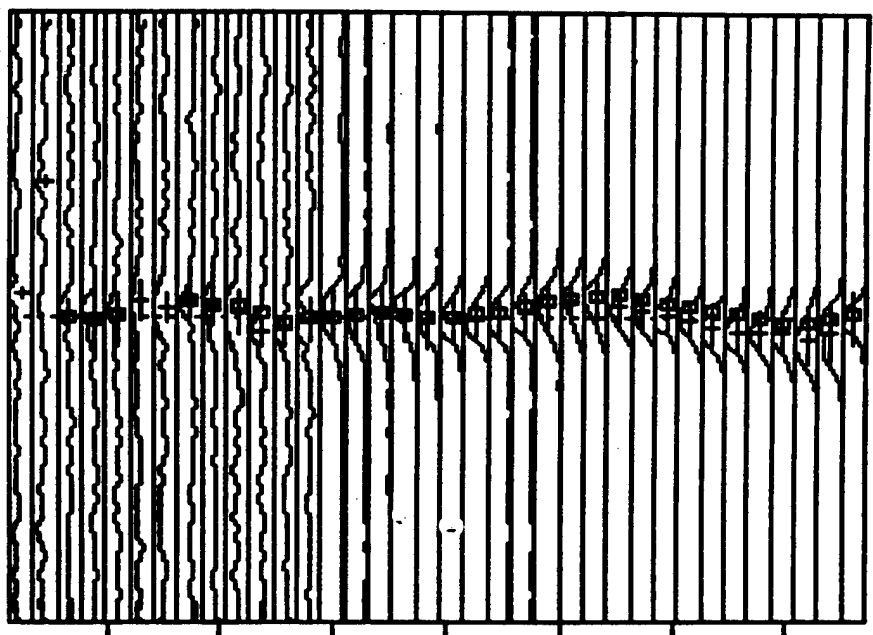

-7.6 m/s (up) Radial 7.6 m/s (down)
Velocity (down)

CLUTTER RM @ 21 HTS
WINDOW+, DCFIL+
SPEC AVG: MEAN

IPP: 59.000 µsec
PW: 2.000
NCI: 180
NSP: 42
NHTS: 36
DLY: 3.300
SPAC: 1.400
NPTS: 64

LINEAR SPECTRA
NORMALIZED

GAIN = 1.000000
DISK WRITE: 32.2% FULL
HTS: ALL,PTS: ALL

ALT+Q PAUSE ALT+X Abort Cns ALT+G Graph/Text F8 Display ALT+F3 New Disk

radar.par, LAP-3000, POP4
1998 Jul 9 Thu 20:10:56 UT Day 190
AZ: 354 EL: 74.5 North BEAM

HT AGL 6.00 km 4.00 km 2.00 km

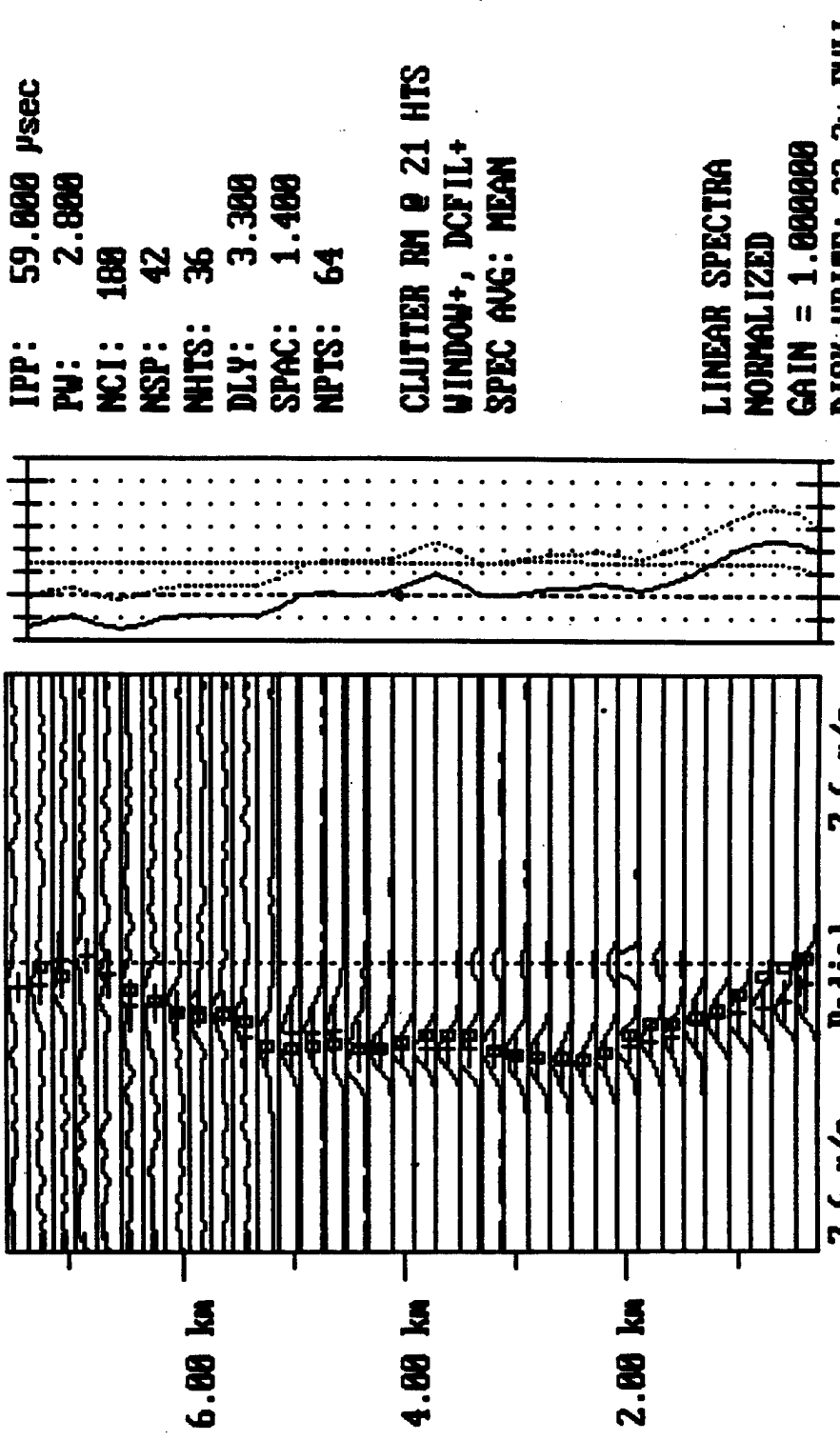

CONSENSING FOR 15 MIN:
4 4 4 4 4

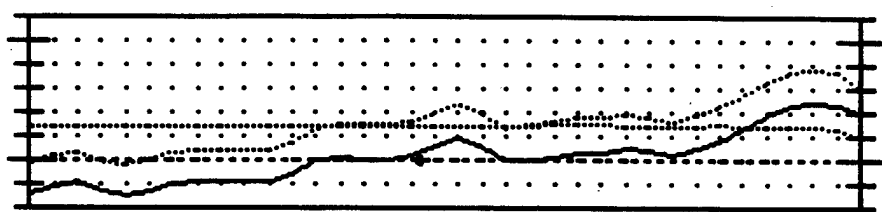

IPP: 59.000 µsec
 PW: 2.800
 NCI: 100
 NSP: 42
 NHTS: 36
 DLY: 3.300
 SPAC: 1.400
 NPTS: 64

CLUTTER RM @ 21 HTS
 WINDOW+, DCFIL+
 SPEC AVG: MEAN

LINEAR SPECTRA
 NORMALIZED
 GAIN = 1.000000
 DISK WRITE: 32.3% FULL
 HTS: ALL,PTS: ALL

ALT+Q PAUSE ALT+X Abort Cns ALT+G Graph/Text F8 Display ALT+F3 New Disk

-7.6 m/s Radial 7.6 m/s
 (away) Velocity (toward) SNR

radar.par, LAP-3000, POP4
1998 Jul 9 Thu 20:11:30 UT Day 190
AZ: 264 EL: 74.5 West BEAM

HT AGL

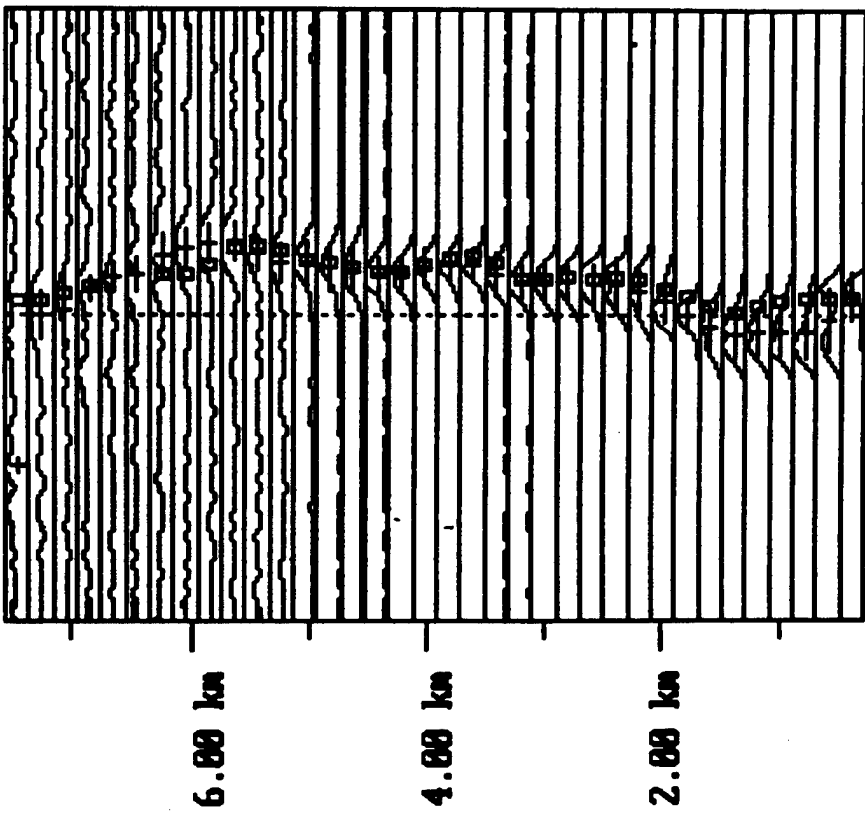

-7.6 m/s (away) Radial Velocity (toward) 7.6 m/s

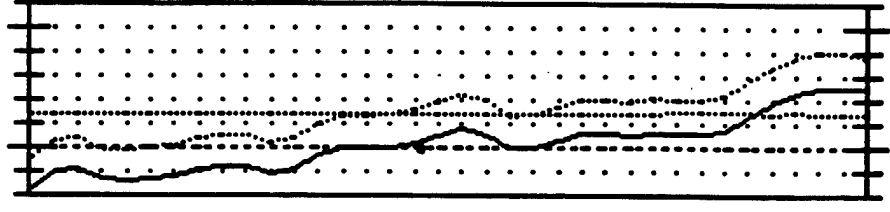

LINEAR SPECTRA
NORMALIZED
GAIN = 1.000000
DISK WRITE: 32.3% FULL
HTS: ALL,PTS: ALL

IPP: 59.000 µsec
PW: 2.800
NCI: 180
NSP: 42
NHTS: 36
DLY: 3.300
SPAC: 1.400
NPTS: 64

CLUTTER RM @ 21 HTS
WINDOW+, DCFIL+
SPEC AVG: MEAN

ALT+Q PAUSE ALT+X Abort Cns ALT+G Graph/Text F8 Display ALT+F3 New Disk

radar.par, LAP-3000, POP4
 1998 Jul 9 Thu 20:12:04 UT Day 190
 AZ: 174 EL: 74.5 South BEAM

HT AGL

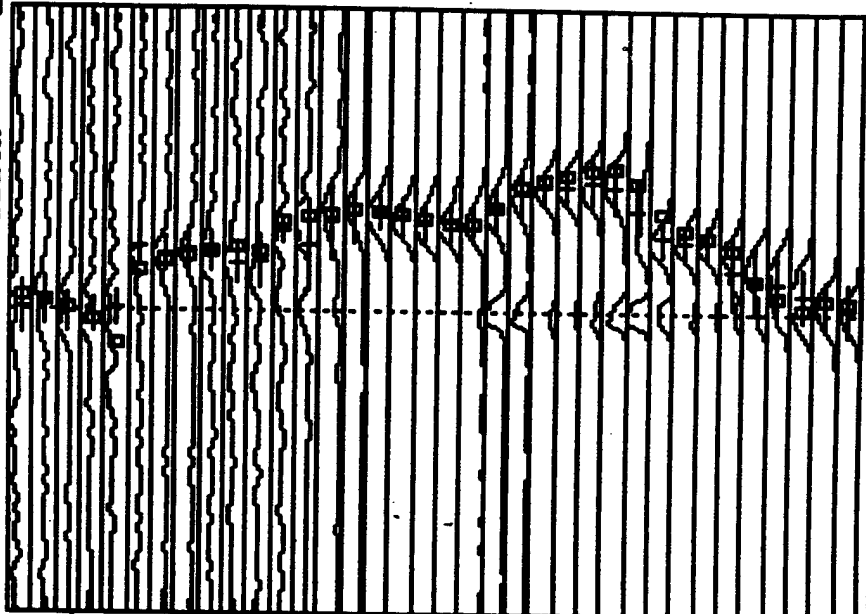

IPP: 59.000 psec
 PW: 2.000
 NCI: 180
 NSP: 42
 NHTS: 36
 DLY: 3.300
 SPAC: 1.400
 NPTS: 64

CLUTTER RM @ 21 HTS
 WINDOW+, DCFIL+
 SPEC AVG: MEAN

LINEAR SPECTRA
 NORMALIZED

GAIN = 1.000000

DISK WRITE: 32.3% FULL

HTS: ALL, PTS: ALL

ALT+Q PAUSE ALT+X Abort Cns ALT+G Graph/Text F8 Display ALT+F3 New Disk

38

radar.par, LAP-3000, POP4
 1998 Jul 9 Thu 20:12:30 UT Day 190
 AZ: 84 EL: 74.5 East BEAM

HT AGL
 6.00 km
 4.00 km
 2.00 km

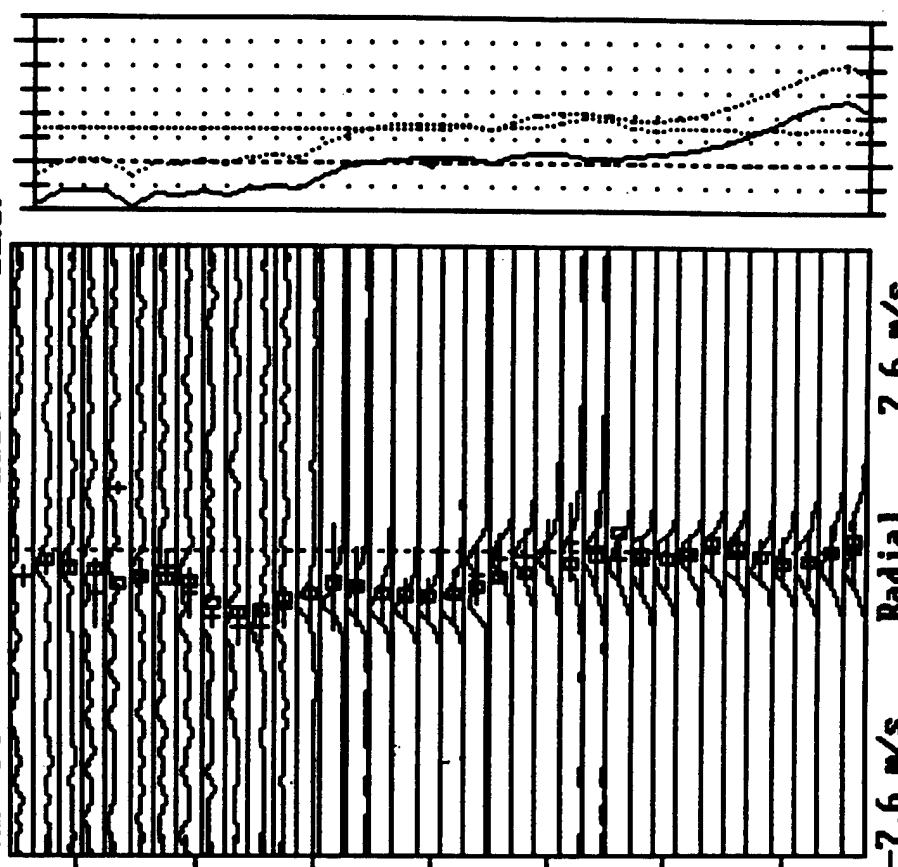

-7.6 m/s Radial Velocity (away) (toward) SNR

ALT+Q PAUSE ALT+X Abort Cns ALT+G Graph/Text FB Display ALT+F3 New Disk

CONSENSING FOR 15 MIN:
 4 4 5 5 5

IPP: 59.0000 μ sec
 PW: 2.0000
 NCI: 180
 NSP: 42
 NHTS: 36
 DLY: 3.3000
 SPAC: 1.4000
 NPTS: 64

CLUTTER RM @ 21 HTS
 WINDOW+, DCFIL+
 SPEC AVG: MEAN

LINEAR SPECTRA
 NORMALIZED
 GAIN = 1.000000
 DISK WRITE: 32.3% FULL
 HTS: ALL,PTS: ALL

CONSENSING FOR 15 MIN:
2 2 1 1 1

radar.par, LAP-3000, POP4
1998 Jul 9 Thu 21:20:19 UT Day 190
AZ: 354 EL: 74.5 North BEAM

IPP: 59.000 psec
PW: 2.800
NCI: 180
NSP: 42
NHTS: 36
DLY: 3.300
SPAC: 1.400
NPTS: 64

CLUTTER RM @ 21 HTS
WINDOW+, DCFIL+
SPEC AVG: MEAN

LINEAR SPECTRA
NORMALIZED

GAIN = 1.000000
DISK WRITE: 33.4% FULL
HTS: ALL,PTS: ALL

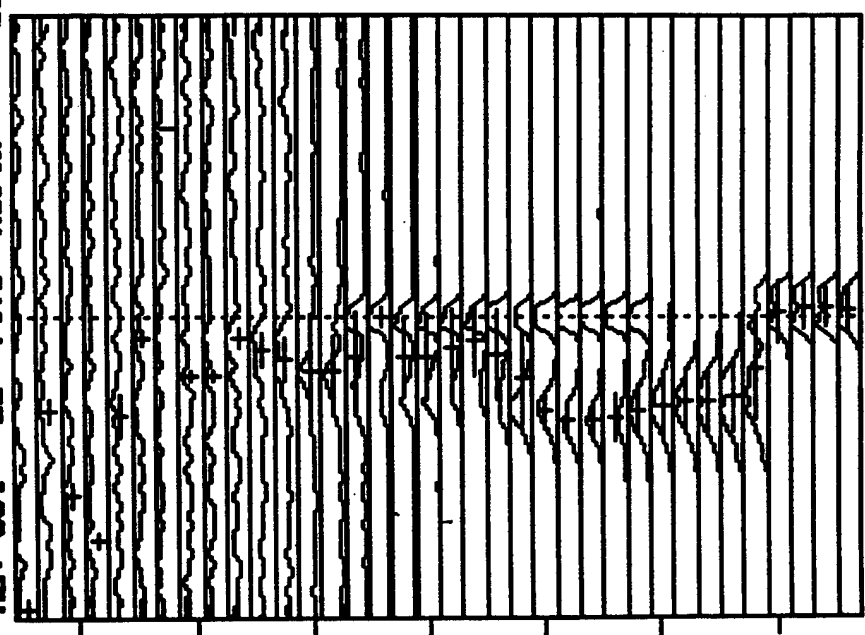

Radial Velocity (toward) SNR
-7.6 m/s (away)

ALI+Q PAUSE ALI+X Abort Cns ALI+G Graph/Text F8 Display ALI+F3 New Disk

radar.par, LAP-3888, POP4
1998 Jul 9 Thu 21:28:53 UT Day 198
AZ: 264 EL: 74.5 West BEAM

HT AGL

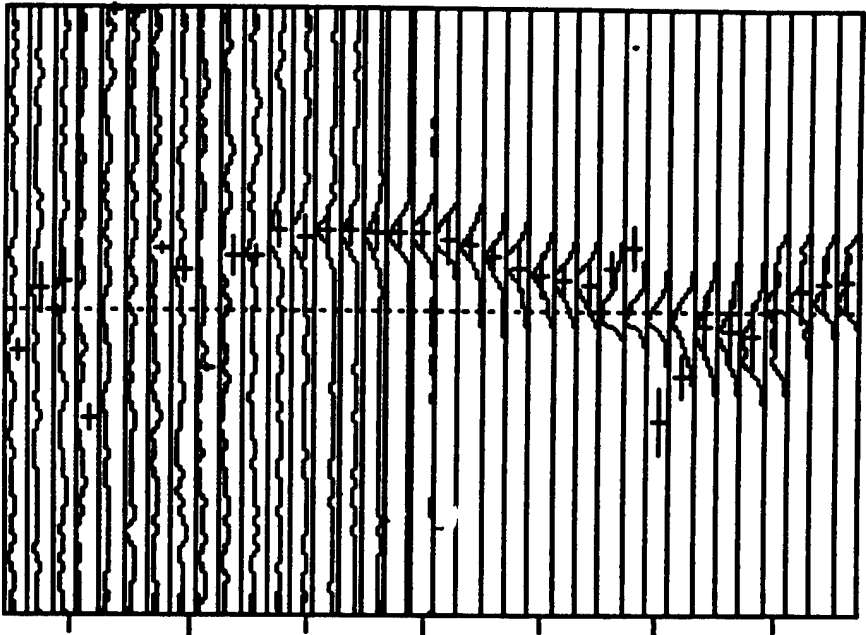

-7.6 m/s Radial Velocity (away)
7.6 m/s (toward)

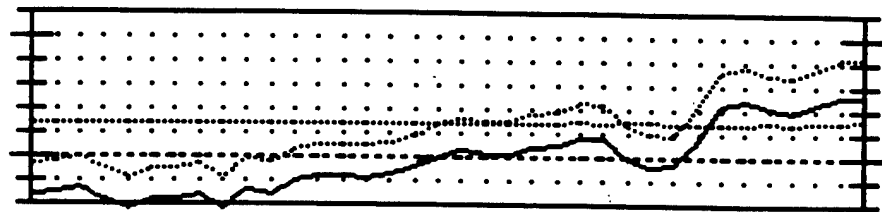

LINEAR SPECTRA
NORMALIZED

GAIN = 1.888888

DISK WRITE: 33.4% FULL

HTS: ALL,PTS: ALL

ALT+Q PAUSE ALT+X Abort Cns ALT+G Graph/Text F8 Display ALT+F3 New Disk

CONSENSING FOR 15 MIN:
2 2 2 1 1

IPP: 59.000 μ sec
PW: 2.888
NCI: 188
NSP: 42
NHTS: 36
DLY: 3.388
SPAC: 1.488
NPTS: 64

CLUTTER RM @ 21 HTS
WINDOW+, DCFIL+
SPEC AVG: MEAN

radar.par, LAP-3000, POP4
 1998 Jul 9 Thu 21:21:27 UT Day 190
 AZ: 174 EL: 74.5 South BEAM

HT AGL
 6.00 km
 4.00 km
 2.00 km

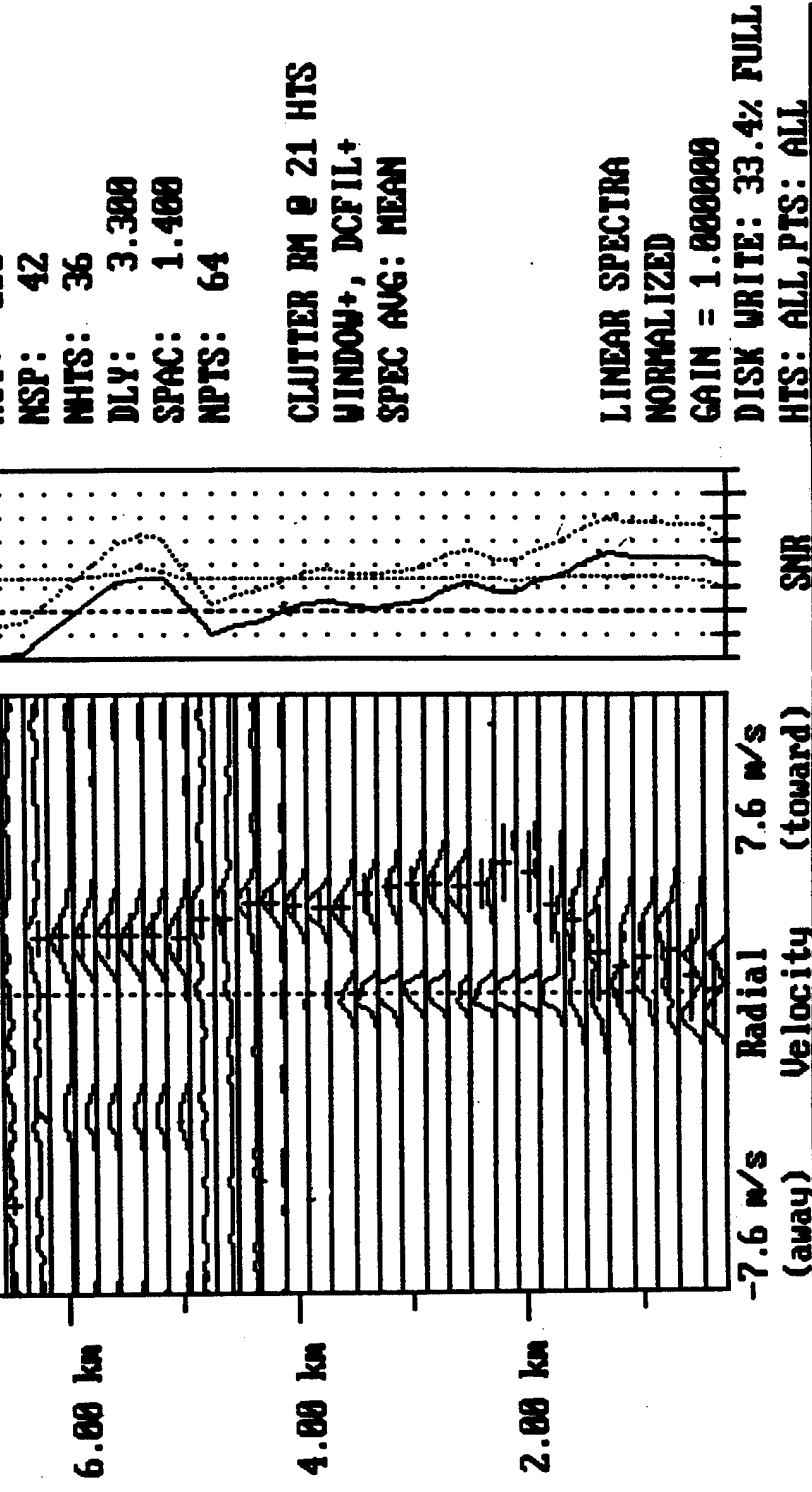

-7.6 m/s Radial 7.6 m/s
 (away) Velocity (toward)
 SNR
 ALT+Q PAUSE ALT+X Abort Cns ALT+G Graph/Text F8 Display ALT+F3 New Disk

CONSENSING FOR 15 MIN:
 2 2 2 2 1

IPP: 59.000 μ sec
 PW: 2.800
 NCI: 180
 NSP: 42
 NHTS: 36
 DLY: 3.300
 SPAC: 1.400
 NPTS: 64

CLUTTER RM @ 21 HTS
 WINDOW+, DCFIL+
 SPEC AVG: MEAN

LINEAR SPECTRA
 NORMALIZED
 GAIN = 1.000000
 DISK WRITE: 33.4% FULL
 HTS: ALL,PTS: ALL

radar.par, LAP-3000, POP4
1998 Jul 9 Thu 21:22:01 UT Day 190
AZ: 84 EL: 74.5 East BEAM

HT AGL

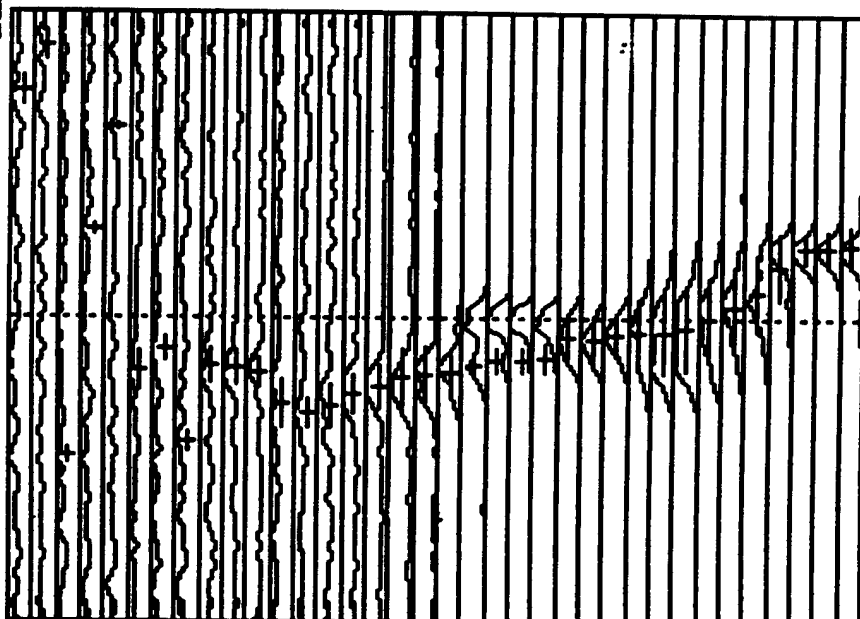

IPP: 59.000 μ sec
 PW: 2.800
 NCI: 180
 NSP: 42
 NHTS: 36
 DLY: 3.300
 SPAC: 1.400
 NPTS: 64

CLUTTER RM @ 21 HTS
 WINDOW+, DCFIL+
 SPEC AVG: MEAN

LINEAR SPECTRA
 NORMALIZED
 GAIN = 1.000000
 DISK WRITE: 33.4% FULL
 HTS: ALL,PTS: ALL

-7.6 m/s Radial 7.6 m/s
 (away) Velocity (toward)

ALT+Q PAUSE ALT+X Abort Cns ALT+G Graph/Text F8 Display ALT+F3 New Disk

radar.par, LAP-3000, POP4
1998 Jul 9 Thu 21:22:35 UT Day 190
AZ: 354 EL: 90.0 X Vertical BEAM

HT AGL

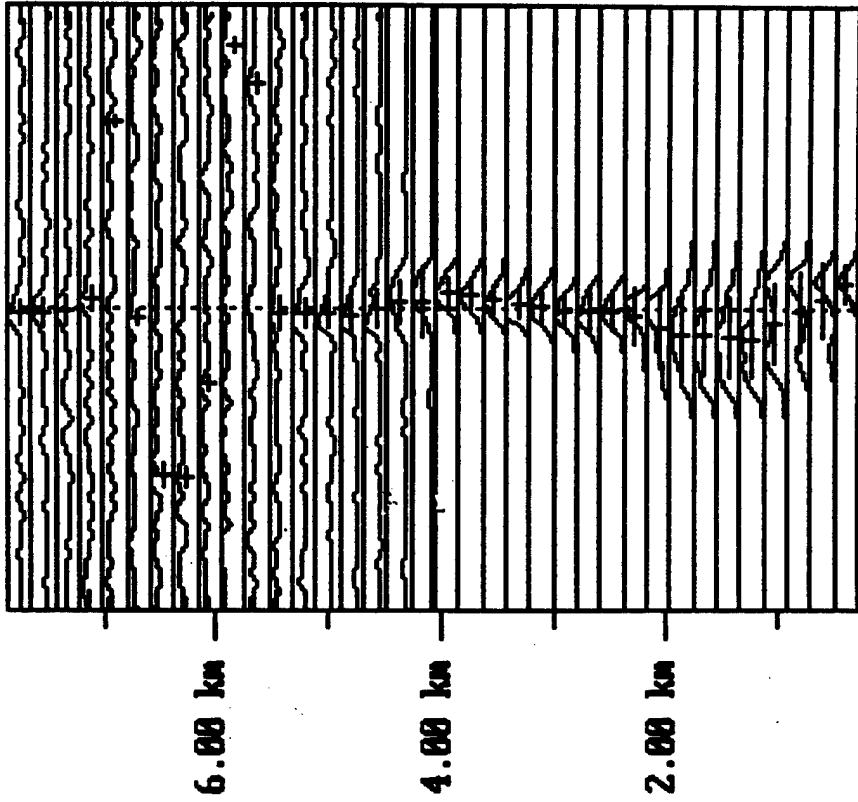

-7.6 m/s (up) Radial Velocity (down) 7.6 m/s

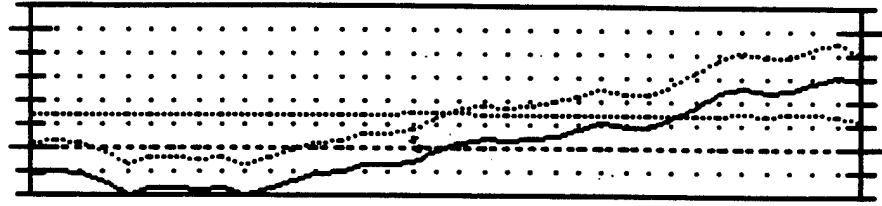

LINEAR SPECTRA
NORMALIZED

GAIN = 1.000000

DISK WRITE: 33.5% FULL

HTS: ALL, PTS: ALL

IPP: 59.000 psec
PW: 2.000
NCI: 180
NSP: 42
NHTS: 36
DLY: 3.300
SPAC: 1.400
NPTS: 64

CLUTTER RM @ 21 HTS
WINDOW+, DCFIL+
SPEC AVG: MEAN

ALT+Q PAUSE ALT+X Abort Cns ALT+G Graph/Text F8 Display ALT+F3 New Disk

radar.par, LAP-3000, POP4
1998 Jul 9 Thu 21:23:09 UT Day 190
AZ: 354 EL: 74.5 North BEAM

HT AGL

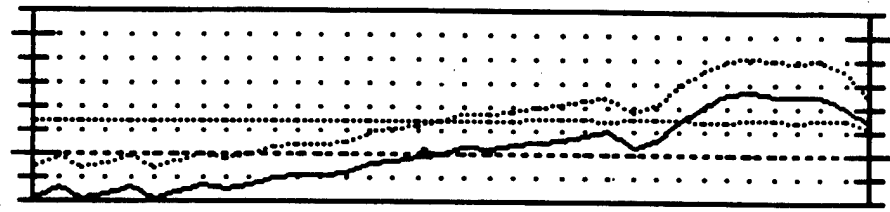
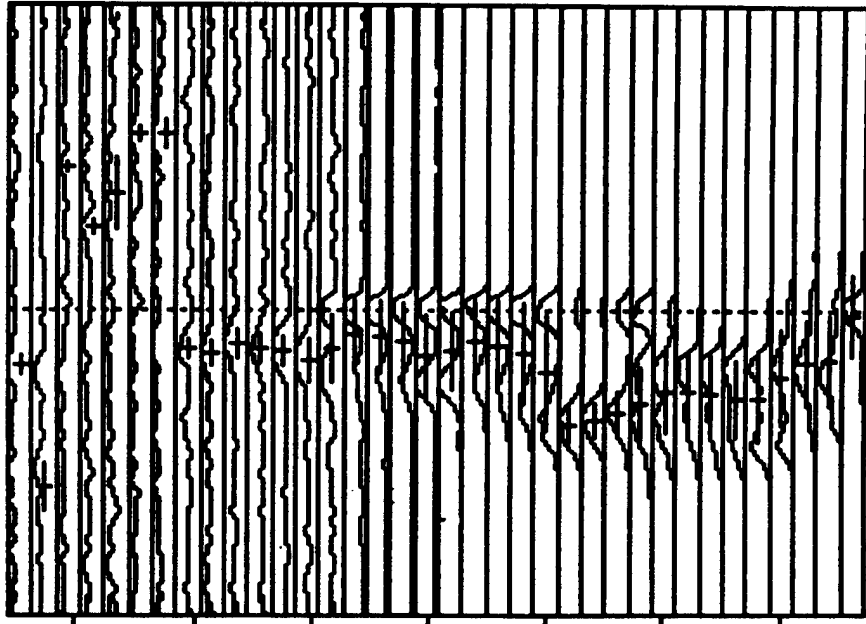

IPP: 59.000 μ sec
 PW: 2.000
 NCI: 100
 MSP: 42
 MHTS: 36
 DLY: 3.300
 SPAC: 1.400
 NPTS: 64

CLUTTER RM @ 21 HTS
 WINDOW+, DCFIL+
 SPEC AVG: MEAN

LINEAR SPECTRA
 NORMALIZED
 GAIN = 1.000000

DISK WRITE: 33.5% FULL

HTS: ALL,PTS: ALL

-7.6 m/s Radial 7.6 m/s
 (away) Velocity (toward)

ALT+Q PAUSE ALT+X Abort Cns ALT+G Graph/Text FB Display ALT+F3 New Disk

radar.par, LAP-3000, POP4
1998 Jul 9 Thu 21:23:43 UT Day 190
AZ: 264 EL: 74.5 West BEAM

HT AGL

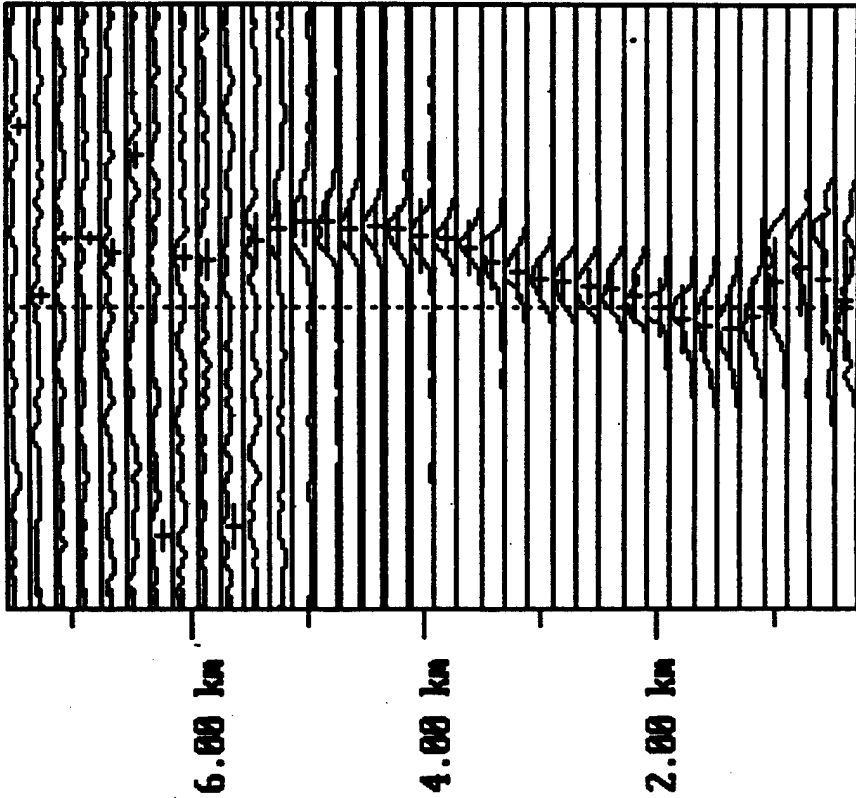

-7.6 m/s Radial 7.6 m/s
(away) Velocity (toward)



LINEAR SPECTRA
NORMALIZED

GAIN = 1.000000

DISK WRITE: 33.5% FULL

HTS: ALL,PTS: ALL

IPP: 59.000 µsec
PW: 2.000
NCI: 180
NSP: 42
NHTS: 36
DLY: 3.300
SPAC: 1.400
NPTS: 64

CLUTTER RM @ 21 HTS
WINDOW+, DCFIL+
SPEC AVG: MEAN

ALT+Q PAUSE ALT+X Abort Cns ALT+G Graph/Text F8 Display ALT+F3 New Disk

radar.par, LAP-3000, POP4
1998 Jul 9 Thu 21:24:17 UT Day 190
AZ: 174 EL: 74.5 South BEAM

HT AGL

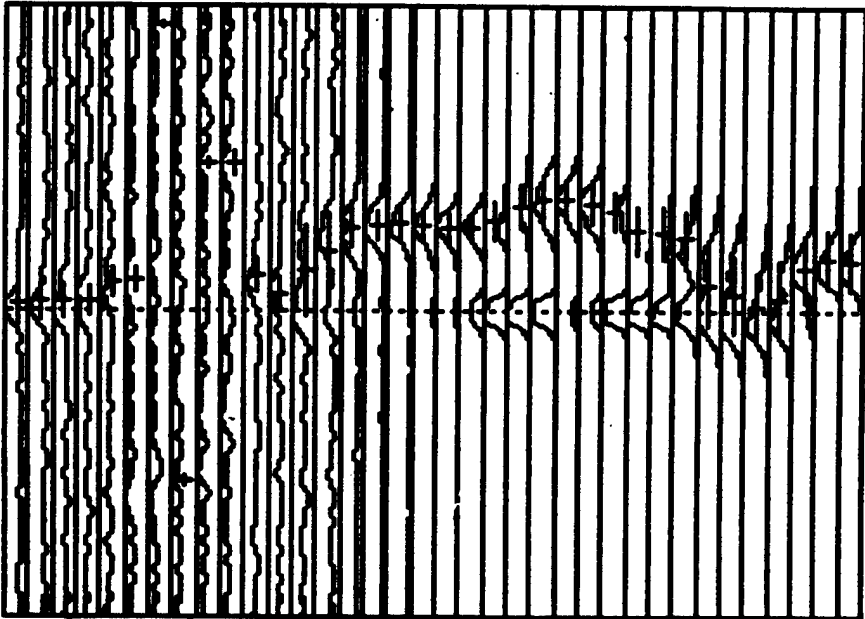

-7.6 m/s Radial 7.6 m/s
(away) Velocity (toward)

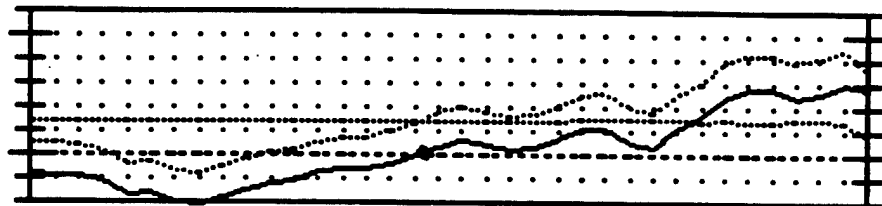

LINEAR SPECTRA
NORMALIZED

GAIN = 1.000000

DISK WRITE: 33.6% FULL

HTS: ALL,PTS: ALL

ALT+Q PAUSE ALT+X Abort Cns ALT+G Graph/Text FB Display ALT+F3 New Disk

CLUTTER RM @ 21 HTS
WINDOW+, DCFIL+
SPEC AVG: MEAN

IPP: 59.000 µsec
PW: 2.800
NCI: 180
NSP: 42
NHTS: 36
DLY: 3.300
SPAC: 1.400
NPTS: 64

CLUTTER RM @ 21 HTS
WINDOW+, DCFIL+
SPEC AVG: MEAN

radar.par, LAP-3000, POP4
1998 Jul 9 Thu 21:24:51 UT Day 190

AZ: 84 EL: 74.5 East BEAM

HT AGL

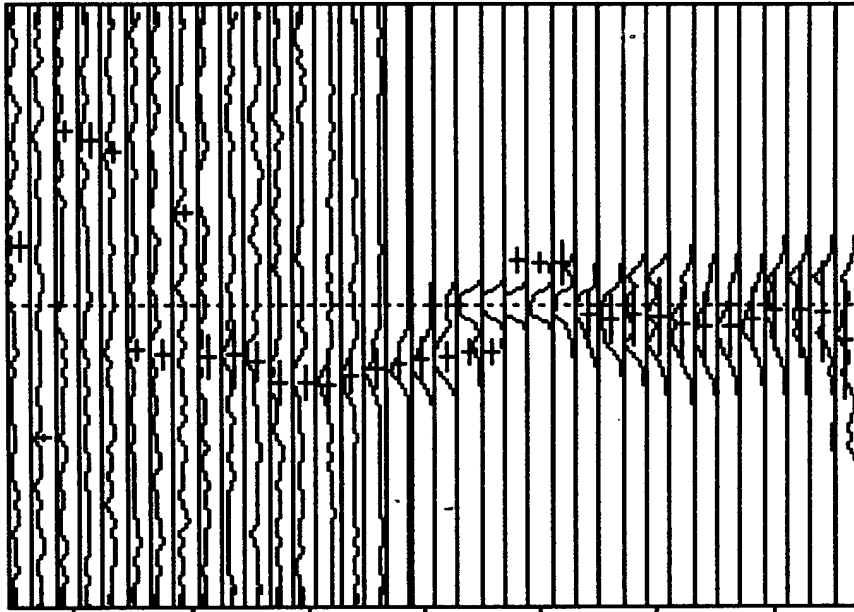

IPP: 59.000 μ sec
PW: 2.800
NCI: 180
NSP: 42
NHTS: 36
DLY: 3.300
SPAC: 1.400
NPTS: 64

CLUTTER RM @ 21 HTS
WINDOW+, DCFIL+
SPEC AVG: MEAN

LINEAR SPECTRA
NORMALIZED

GAIN = 1.000000

DISK WRITE: 33.6% FULL

HTS: ALL,PTS: ALL

ALT+Q PAUSE ALT+X Abort Cns ALT+G Graph/Text FB Display ALT+F3 New Disk

radar.par, LAP-3000, POP4
1998 Jul 9 Thu 21:25:25 UT Day 190
AZ: 354 EL: 90.0 X Vertical BEAM

HT AGL

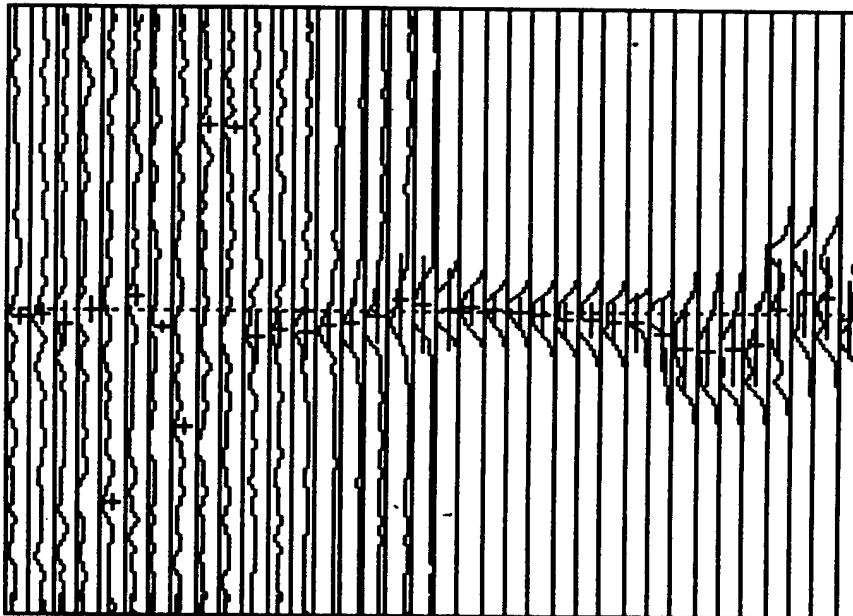

-7.6 m/s (up) Radial Velocity (down) 7.6 m/s

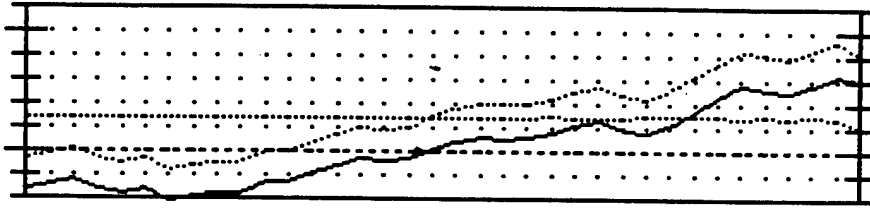

SNR

IPP: 59.000 µsec
PW: 2.800
NCI: 180
NSP: 42
NHTS: 36
DLY: 3.300
SPAC: 1.400
NPTS: 64

CLUTTER RM @ 21 HTS
WINDOW+, DCFIL+
SPEC AVG: MEAN

LINEAR SPECTRA
NORMALIZED

GAIN = 1.000000

DISK WRITE: 33.6% FULL

HTS: ALL, PTS: ALL

ALT+Q PAUSE ALT+X Abort Cns ALT+G Graph/Text F8 Display ALT+F3 New Disk

Distribution

	<u>Copies</u>
NASA MARSHALL SPACE FLT CTR ATMOSPHERIC SCIENCES DIV E501 ATTN DR FICHTL HUNTSVILLE AL 35802	1
NASA SPACE FLT CTR ATMOSPHERIC SCIENCES DIV CODE ED 41 1 HUNTSVILLE AL 35812	1
US ARMY STRAT DEFNS CMND CSSD SL L ATTN DR LILLY PO BOX 1500 HUNTSVILLE AL 35807-3801	1
US ARMY MISSILE CMND AMSMI RD AC AD ATTN DR PETERSON REDSTONE ARSENAL AL 35898-5242	1
US ARMY MISSILE CMND AMSMI RD AS SS ATTN MR H F ANDERSON REDSTONE ARSENAL AL 35898-5253	1
US ARMY MISSILE CMND AMSMI RD AS SS ATTN MR B WILLIAMS REDSTONE ARSENAL AL 35898-5253	1
US ARMY MISSILE CMND AMSMI RD DE SE ATTN MR GORDON LILL JR REDSTONE ARSENAL AL 35898-5245	1
US ARMY MISSILE CMND REDSTONE SCI INFO CTR AMSMI RD CS R DOC REDSTONE ARSENAL AL 35898-5241	1
US ARMY MISSILE CMND AMSMI REDSTONE ARSENAL AL 35898-5253	1
PACIFIC MISSILE TEST CTR GEOPHYSICS DIV ATTN CODE 3250 POINT MUGU CA 93042-5000	1

NAVAL OCEAN SYST CTR CODE 54 ATTN DR RICHTER SAN DIEGO CA 52152-5000	1
METEOROLOGIST IN CHARGE KWAJALEIN MISSILE RANGE PO BOX 67 APO SAN FRANCISCO CA 96555	1
DEPT OF COMMERCE CTR MOUNTAIN ADMINISTRATION SPPRT CTR LIBRARY R 51 325 S BROADWAY BOULDER CO 80303	1
DR HANS J LIEBE NTIA ITS S 3 325 S BROADWAY BOULDER CO 80303	1
NCAR LIBRARY SERIALS NATL CTR FOR ATMOS RSCH PO BOX 3000 BOULDER CO 80307-3000	1
HEADQUARTERS DEPT OF ARMY DAMI POI ATTN LEE PAGE WASHINGTON DC 20310-1067	1
MIL ASST FOR ENV SCI OFC OF THE UNDERSEC OF DEFNS FOR RSCH & ENGR R&AT E LS PENTAGON ROOM 3D129 WASHINGTON DC 20301-3080	1
DEAN RMD ATTN DR GOMEZ WASHINGTON DC 20314	1
US ARMY INFANTRY ATSH CD CS OR ATTN DR E DUTOIT FT BENNING GA 30905-5090	1
AIR WEATHER SERVICE TECH LIBRARY FL4414 3 SCOTT AFB IL 62225-5458	1
USAFETAC DNE ATTN MR GLAUBER SCOTT AFB IL 62225-5008	1
HQ AFWA/DNX 106 PEACEKEEPER DR STE 2N3 OFFUTT AFB NE 68113-4039	1

PHILLIPS LABORATORY PL LYP ATTN MR CHISHOLM HANSCOM AFB MA 01731-5000	1
ATMOSPHERIC SCI DIV GEOPHYISCS DIRCTR PHILLIPS LABORATORY HANSCOM AFB MA 01731-5000	1
US ARMY MATERIEL SYST ANALYSIS ACTIVITY AMXSY ATTN MR H COHEN APG MD 21005-5071	1
US ARMY MATERIEL SYST ANALYSIS ACTIVITY AMXSY AT ATTN MR CAMPBELL APG MD 21005-5071	1
US ARMY MATERIEL SYST ANALYSIS ACTIVITY AMXSY CR ATTN MR MARCHET APG MD 21005-5071	1
ARL CHEMICAL BIOLOGY NUC EFFECTS DIV AMSRL SL CO APG MD 21010-5423	1
US ARMY MATERIEL SYST ANALYSIS ACTIVITY AMSXY APG MD 21005-5071	1
ARMY RESEARCH LABORATORY AMSRL D 2800 POWDER MILL ROAD ADELPHI MD 20783-1145	1
ARMY RESEARCH LABORATORY AMSRL OP CI SD TL 2800 POWDER MILL ROAD ADELPHI MD 20783-1145	1
ARMY RESEARCH LABORATORY AMSRL IS ATTN J GANTT 2800 POWDER MILL ROAD ADELPHI MD 20783-1197	1
ARMY RESEARCH LABORATORY AMSRL 2800 POWDER MILL ROAD ADLEPHI MD 20783-1145	1

NATIONAL SECURITY AGCY W21 ATTN DR LONGBOTHUM 9800 SAVAGE ROAD FT GEORGE G MEADE MD 20755-6000	1
US ARMY RSRC OFC ATTN AMXRO GS DR BACH PO BOX 12211 RTP NC 27009	1
US ARMY CECRL CECRL GP ATTN DR DETSCH HANOVER NH 03755-1290	1
US ARMY ARDEC SMCAR IMI I BLDG 59 DOVER NJ 07806-5000	1
US ARMY COMMUNICATIONS ELECTR CTR FOR EW RSTA AMSRL EW D FT MONMOUTH NJ 07703-5303	1
US ARMY COMMUNICATIONS ELECTR CTR FOR EW RSTA AMSRL EW MD FT MONMOUTH NJ 07703-5303	1
ARMY DUGWAY PROVING GRD STEDP MT DA L 3 DUGWAY UT 84022-5000	1
ARMY DUGWAY PROVING GRD STEDP MT M ATTN MR BOWERS DUGWAY UT 84022-5000	1
DEPT OF THE AIR FORCE OL A 2D WEATHER SQUAD MAC HOLLOMAN AFB NM 88330-5000	1
PL WE KIRTLAND AFB NM 87118-6008	1
USAF ROME LAB TECH CORRIDOR W STE 262 RL SUL 26 ELECTR PKWY BLD 106 GRIFFISS AFB NY 13441-4514	1
AFMC DOW WRIGHT PATTERSON AFB OH 45433-5000	1
US ARMY FIELD ARTILLERY SCHOOL ATSF TSM TA FT SILL OK 73503-5600	1

US ARMY FOREIGN SCI TECH CTR CM 220 7TH STREET NE CHARLOTTESVILLE VA 22448-5000	1
NAVAL SURFACE WEAPONS CTR CODE G63 DAHLGREN VA 22448-5000	1
US ARMY OEC CSTE EFS PARK CENTER IV 4501 FORD AVE ALEXANDRIA VA 22302-1458	1
US ARMY CORPS OF ENGRS ENGR TOPOGRAPHICS LAB ETL GS LB FT BELVOIR VA 22060	1
US ARMY TOPO ENGR CTR CETEC ZC 1 FT BELVOIR VA 22060-5546	1
US ARMY NUCLEAR CML AGCY MONA ZB BLDG 2073 SPRINGFIELD VA 22150-3198	1
USATRADOC ATCD FA FT MONROE VA 23651-5170	1
ATRC WSS R WSMR NM 88002-5502	1
ARMY RESEARCH LABORATORY AMSRL IS E INFO SCI & TECH DIR WSMR NM 88002-5501	1
DTIC 8725 JOHN J KINGMAN RD STE 0944 FT BELVOIR VA 22060-6218	1
US ARMY MISSILE CMND AMSMI REDSTONE ARSENAL AL 35898-5243	1
US ARMY DUGWAY PROVING GRD STEDP3 DUGWAY UT 84022-5000	1
USTRADOC ATCD FA FT MONROE VA 23651-5170	1

WSMR TECH LIBRARY BR STEWS IM IT WSMR NM 88002	1
US MILITARY ACADEMY DEPT OF MATHEMATICAL SCIENCES ATTN MDN A MAJ DON ENGEN THAYER HALL WEST POINT NY 10996-1786	1
ARMY RESEARCH LABORATORY ARTILLERY METEROLOGY BRANCH CHIEF AMSRL IS EA WSMR NM 88002-5501	1
ARMY RESEARCH LABORATORY ATTN MS GAIL T VAUCHER AMSRL IS EA WSMR NM 88002-5501	15
ARMY RESEARCH LABORATORY ATTN MR EDWARD CREEGAN AMSRL IS EA WSMR NM 88002-5501	2
ARMY RESEARCH LABORATORY ATTN MR JIMMY YARBROUGH AMSRL IS EA WSMR NM 88002-5501	2
ARMY RESEARCH LABORATORY MS&F TEAM LEADER AMSRL IS EA WSMR NM 88002-5501	1
DR BOB WEBER US DEPT OF COMMERCE, NOAA MC R/E/ET4 325 BROADWAY BOULDER CO 80303	1
ARMY RESEARCH LABORATORY MR STAN PARSONS STEWS NRO DA STAN WSMR NM 88002-5501	1
Record copy	1
TOTAL	85