

LOAN DOCUMENT

PHOTOGRAPH THIS SHEET

DTIC ACCESSION NUMBER

LEVEL

INVENTORY

AFRL-ML-TY-TR-1997-4521

DOCUMENT IDENTIFICATION

JUN 1997

DISTRIBUTION STATEMENT A:
Approved for Public Release -
Distribution Unlimited

DISTRIBUTION STATEMENT

ACCESSION FOR	
NTIS	GRAM
DTIC	TRAC
UNANNOUNCED	<input type="checkbox"/>
JUSTIFICATION	
BY	
DISTRIBUTION/	
AVAILABILITY CODES	
DISTRIBUTION	AVAILABILITY AND/OR SPECIAL
A-1	

DISTRIBUTION STAMP

Reproduced From
Best Available Copy

19981216 034

DATE RECEIVED IN DTIC

REGISTERED OR CERTIFIED NUMBER

PHOTOGRAPH THIS SHEET AND RETURN TO DTIC-FDAC

H
A
N
D
L
E

W
I
T
H

C
A
R
E

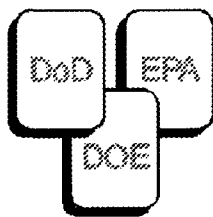

SERDP

Strategic Environmental Research
and Development Program

Improving Mission Readiness through
Environmental Research



AFRL-ML-TY-TR-1997-4521

CONTROLLING COMBUSTION-SOURCE EMISSIONS AT AIR FORCE SITES

S.G. NELSON, R.A. BABYAK AND B.C. CIANCIOLO
SORBENT TECHNOLOGIES CORPORATION
1664 EAST HIGHLAND ROAD
TWINSBURG OH 44087

JUNE 1997

FINAL REPORT: AUGUST 1994 – JUNE 1997

Approved for public release; distribution is unlimited.

AIR FORCE RESEARCH LABORATORY
MATERIALS & MANUFACTURING DIRECTORATE
AIRBASE & ENVIRONMENTAL TECHNOLOGY DIVISION
TYNDALL AFB FL 32403-5323

NOTICES

WHEN GOVERNMENT DRAWINGS, SPECIFICATIONS, OR OTHER DATA INCLUDED IN THIS DOCUMENT FOR ANY PURPOSE OTHER THAN GOVERNMENT PROCUREMENT DOES NOT IN ANY WAY OBLIGATE THE US GOVERNMENT. THE FACT THAT THE GOVERNMENT FORMULATED OR SUPPLIED THE DRAWINGS, SPECIFICATIONS, OR OTHER DATA DOES NOT LICENSE THE HOLDER OR ANY OTHER PERSON OR CORPORATION, OR CONVEY ANY RIGHTS OR PERMISSION TO MANUFACTURE, USE, OR SELL ANY PATENTED INVENTION THAT MAY RELATE TO THEM.

THIS REPORT IS RELEASABLE TO THE NATIONAL TECHNICAL INFORMATION SERVICE (NTIS). AT NTIS, IT WILL BE AVAILABLE TO THE GENERAL PUBLIC, INCLUDING FOREIGN NATIONS.

THIS TECHNICAL REPORT HAS BEEN REVIEWED AND IS APPROVED FOR PUBLICATION.

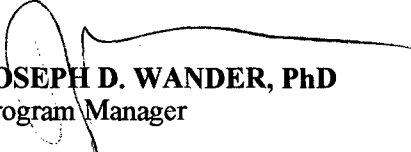

JOSEPH D. WANDER, PhD
Program Manager



CHRISTINE. WAGENER-HULME, Lt Col, USAF, BSC
Chief, Environmental Technology Development Branch

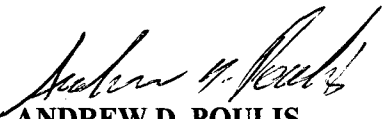

ANDREW D. POULIS
Scientific & Technical
Information Program Manager



NEIL J. LAMB, Col, USAF, BSC
Chief, Airbase & Environmental Technology Division

IF YOUR ADDRESS HAS CHANGED, IF YOU WISH TO BE REMOVED FROM OUR MAILING LIST, OR IF THE ADDRESSEE IS NO LONGER EMPLOYED BY YOUR ORGANIZATION, PLEASE NOTIFY AFRL/MLQP, TYNDALL AFB, FLORIDA 32403-5323, TO HELP MAINTAIN A CURRENT MAILING LIST.

Do not return copies of this report unless contractual obligations or notice on a specific document requires its return.

REPORT DOCUMENTATION PAGE			Form Approved OMB No. 0704-0188	
Public reporting burden for this collection of information is estimated to average 1 hour per response, including the time for reviewing instructions, searching existing data sources, gathering and maintaining the data needed, and completing and reviewing the collection of information. Send comments regarding this burden estimate or any other aspect of this collection of information, including suggestions for reducing this burden, to Washington Headquarters Services, Directorate for Information Operations and Reports, 1215 Jefferson Davis Highway, Suite 1204, Arlington, VA 22202-4302, and to the Office of Management and Budget, Paperwork Reduction Project (0704-0188), Washington, DC 20503.				
1. AGENCY USE ONLY (Leave blank)	2. REPORT DATE June 1997	3. REPORT TYPE AND DATES COVERED Final Report: Aug 94 - June 97		
4. TITLE AND SUBTITLE Controlling Combustion-Source Emissions at Air Force Sites			5. FUNDING NUMBERS C - F08637-94-C-6026 Project #4223 Work Unit #S401	
6. AUTHOR(S) S.G. Nelson, R.A. Babyak and B.C. Cianciolo				
7. PERFORMING ORGANIZATION NAME(S) AND ADDRESS(ES) Sorbent Technologies Corporation 1664 East Highland Road Twinsburg OH 44087			8. PERFORMING ORGANIZATION REPORT NUMBER	
9. SPONSORING/MONITORING AGENCY NAME(S) AND ADDRESS(ES) AFRL/MLQE 139 Barnes Drive, Suite 2, Tyndall Air Force Base, Florida 32403-5323			10. SPONSORING/MONITORING AGENCY REPORT NUMBER AFRL-ML-TY-TR-1998-4521	
11. SUPPLEMENTARY NOTES Technical Monitor is Dr. Joe Wander, AFRL/MLQE (850) 283-6240 or DSN 523-6240				
12a. DISTRIBUTION AVAILABILITY STATEMENT Approved for public release; distribution unlimited.			12b. DISTRIBUTION CODE A	
13. ABSTRACT (Maximum 200 words) This report describes the development and demonstration of several new technologies for controlling air pollutants, particularly nitrogen oxides (NOx) and small particulates. It provides the results of a project undertaken to investigate potential NOx problems at military sites and to develop potential solutions. Work on the project was performed primarily at McClellan AFB in California and at Sorbent Technologies' facilities in Ohio. The research work involved gas-cleaning approaches and centered on exhaust gases from radiant tube heaters for paint drying, mobile diesel generators, stationary diesel generators, diesel buses and trucks, incinerators, and natural-gas-fired boilers. Major sources of NOx and small particulate emissions at McClellan AFB were observed to be units that burn diesel fuels. These included mobile and stationary generators, trucks and buses. Two new technologies to control NOx and one new technology to control small particulates were successfully developed and demonstrated.				
14. SUBJECT TERMS NOx, particulates, diesel generators, AGE, radiant tube heaters, buses, trucks, incinerators			15. NUMBER OF PAGES 120	
			16. PRICE CODE	
17. SECURITY CLASSIFICATION OF REPORT UNCLASSIFIED	18. SECURITY CLASSIFICATION OF THIS PAGE UNCLASSIFIED	19. SECURITY CLASSIFICATION OF ABSTRACT UNCLASSIFIED	20. LIMITATION OF ABSTRACT UL	

UNCLASSIFIED

SECURITY CLASSIFICATION OF THIS PAGE

CLASSIFIED BY:

DECLASSIFY ON:

SECURITY CLASSIFICATION OF THIS PAGE

UNCLASSIFIED

PREFACE

This report was prepared by Sorbent Technologies Corporation, Twinsburg, OH 44087, under Contract F08637-94-C6026 for the Department of the Air Force, Armstrong Laboratory Environics Directorate (AL/EQ), 139 Barnes Drive, Suite 2, Tyndall AFB FL 32403-5323. It describes research supported by the Small Business Innovation Research (SBIR) program and, in part, by the Strategic Environmental Research and Development Program (SERDP).

The report describes potential NO_x problems at Air Force sites and the development of possible solutions. A large portion of the work was carried out at McClellan AFB. The work was performed between August 1994 and June 1997. The Air Force project officers were Dr. Joseph D. Wander of AL/EQS and Mr. C. Alan Canfield of Applied Research Associates, Inc. Valuable assistance at McClellan AFB was provided by John Carroz of SMALC/EMPW and by other members of the McClellan AFB staff.

EXECUTIVE SUMMARY

A. OBJECTIVE

The purpose of this document is to describe the development and demonstration of several new technologies for controlling air pollutants, particularly nitrogen oxides (NO_x) and small particulates.

B. BACKGROUND

NO_x stands out as one of the most difficult air pollutants to control. The U.S. Air Force employs many different combustion sources that emit NO_x at its facilities around the world. Increased attention is being given to NO_x because of the role it plays in acid rain, smog, ozone depletion, and impacts on human health. This has led to regulations on NO_x emissions. The Federal Clean Air Act Amendments, for example, have set tough standards for NO_x nonattainment areas, many of which include Air Force sites.

Environmental regulations and emission limits often make it difficult for the Air Force to add needed new facilities that generate emissions. Sometimes the only way new facilities can be added is if undesirable emissions of older facilities are reduced or if special credits are purchased [if they are available to be purchased]. Reducing the levels of NO_x and other pollutants at specific Air Force sites can provide valuable credits for the sites. This is particularly important for locations such as McClellan AFB, California, which is in a nonattainment area.

It is unfortunate that, in many cases, simple, low-cost methods are not available to adequately control many of the pollutants of concern. Some people believe that the best commercially available exhaust-gas treatment technology to reduce NO_x emissions today is selective catalytic reduction (SCR). However, SCR is expensive, is limited to relatively narrow temperature ranges, is only partially effective in reducing NO_x, and requires ammonia additions to the exhaust gas that often slips into the atmosphere. A definite need exists today for simpler, less-costly technologies to control NO_x in exhaust gases.

C. SCOPE

This document provides the results of a project undertaken to investigate potential air pollution problems at military sites and to develop possible solutions.

Work on the project was performed primarily at McClellan AFB in California and at Sorbent Technologies Corporation's facilities in Ohio. The research work involved gas-cleaning approaches and centered on exhaust gases from radiant tube heaters for paint drying, mobile diesel generators, stationary diesel generators, diesel buses and trucks, incinerators, and natural-gas-fired boilers. Jet engine test cells were also identified as heavy emitters of NO_x, but were not addressed in the project.

D. RESULTS

Major sources of NO_x and small particulate emissions at McClellan AFB were observed to be units that burn diesel fuels. These included aerospace ground equipment (AGE), mobile generators, stationary generators, trucks, and buses. High NO_x levels (up to 1000 ppm) and high particulate levels, with large concentrations of both PM-10 and PM-2.5 particles, were seen.

Two new technologies to control NO_x and one new technology to control small particulates were developed in the project.

For mobile diesel applications, a filter composed of a special activated carbon achieved NO_x removals approaching 100 percent for long time periods. Once saturated with NO_x, the filter material was regenerable. NO_x released during regeneration was destroyed by methods developed and demonstrated in the project.

For stationary diesel applications, a NO_x-control process consisting of two steps was developed. In the first step, NO in the exhaust gases was converted to NO₂; in the second step, the NO₂ was scrubbed from the exhaust gases. Keys to the process were two catalysts, one carbon-based and one metal-based, over which the exhaust gases were passed. NO_x removals greater than 90 percent were seen with the new process.

A filter for capturing and removing particulates, especially sub-micron particles, was successfully demonstrated. The filter, comprised of vermiculite, silica and/or magnesia, performed particularly well as a prefilter in front of activated carbon beds. Particulate removals typically were over 90 percent. A filter cart for controlling emissions from AGE and similar equipment was designed, constructed and demonstrated. The cart consisted of the new particulate filter, an air-to-air heat exchanger, a demister, and two banks of carbon filters.

Other studies described in the report examined the application of the new filter materials to radiant tube heaters, to natural gas boilers, and to diesel buses and trucks; the NO_x-reduction capability of vermiculite in the presence of CO; the use of ozone for the conversion of NO into NO₂; and the disposal of filter materials after their useful lives. A small filter of vermiculite and magnesia reduced NO_x levels in radiant tube heaters, but was found unnecessary when a reexamination of emission calculations showed that the heaters were in compliance with NO_x standards. Vermiculite alone was not effective in reducing NO_x levels unless CO was present. With CO present at levels above 250 ppm, small amounts of NO_x reduction occurred in the presence of vermiculite. Exhaust gas recycling reduced NO_x levels significantly in the natural gas boilers at McClellan AFB. The NO_x and small-particle filters were effective in controlling both bus and truck emissions. Ozone was observed to convert NO into NO₂ very effectively, but was also determined to be very expensive to employ. Used filter materials appeared to present no disposal problems after their useful lives.

The cost of combined NO_x and small particulates' control with the activated carbon-based system was projected to be less than \$3,000 per ton of NO_x removed. The cost of NO_x-control with the NO-into-NO₂ catalyst/wet-scrubbing system was estimated to be less than \$2,000 per ton of NO_x removed.

E. CONCLUSIONS

Major emitters of NO_x and particulates at Air Force sites include jet engine test cells and combustion systems that burn diesel fuels. Few, if any, commercial systems are available to control these emissions. Two new exhaust-gas treatment technologies were developed in the project that demonstrated promising results in controlling NO_x and small particulates. One was a NO_x and small particle filter; the second was a NO_x scrubbing process. Both technologies demonstrated the ability to remove nearly all NO_x and particulates from diesel engine exhaust gases.

F. RECOMMENDATIONS

It is recommended that development work on the NO_x and small particle filter continue, specifically addressing the optimization of the sorbent regeneration process and the demonstration of regeneration-in-place in mobile-generator, tow-motor and fork-lift applications. It is further recommended that a full commercial-scale demonstration of the new NO_x-scrubbing process be carried out treating the exhaust gases of a large, stationary, diesel-powered generator.

TABLE OF CONTENTS

Section	Title	Page
I	INTRODUCTION	1
	A. OBJECTIVE	1
	B. BACKGROUND	1
	C. SCOPE	3
II	RADIANT TUBE HEATERS	4
	A. BACKGROUND	4
	B. APPROACH AND RESULTS	4
	C. DISCUSSION OF RESULTS	11
III	LABORATORY STUDIES	12
	A. NO _x SORPTION WITH ACTIVATED CARBON	12
	B. ACTIVATED CARBON REGENERATION AND NO _x DESTRUCTION	12
	C. PREFILTER STUDIES	21
	D. STUDIES AT PENNSYLVANIA STATE UNIVERSITY	21
	E. DISPOSAL OF FILTER WASTES	25
IV	MOBILE DIESEL GENERATORS	27
	A. BACKGROUND	27
	B. PRELIMINARY TEST WORK	27
	C. INITIAL MOBILE FILTER TRIALS	31
	D. FIVE APPLICATIONS EXAMINED AT McCLELLAN AFB	33
	E. APPLYING REGENERATION AND NO _x DESTRUCTION TO THE FILTER CART ...	34
	F. DISCUSSION OF RESULTS	35
	G. FILTER CART/NO _x DESTRUCTION COSTS	42
V	STATIONARY DIESEL GENERATORS	45
	A. BACKGROUND	45
	B. APPROACHES	45
	C. DISCUSSION OF RESULTS	47
	D. NO-TO-NO ₂ AND WET SCRUBBING COSTS	63
VI	DIESEL BUSES AND TRUCKS	66
	A. BACKGROUND	66
	B. APPROACHES	66
	C. DISCUSSION OF RESULTS	66

TABLE OF CONTENTS (continued)

Section	Title	Page
VII	INCINERATORS AND NATURAL-GAS-FIRED BOILERS	77
	A. BACKGROUND	77
	B. APPROACHES	77
	C. DISCUSSION OF RESULTS	79
VIII	CONCLUSIONS AND RECOMMENDATIONS	81
	A. CONCLUSIONS	81
	B. RECOMMENDATIONS	83
	REFERENCES	84
	APPENDICES	85

LIST OF FIGURES

Figure	Title	Page
1	Aircraft Repainting Facility at McClellan AFB	5
2	A Sketch of Radiant Tube Heaters	5
3	A Simple Rectangular Filter Design was Selected for the Heater Filter	7
4	Filter and Equipment Arrangement for Filter Tests	8
5	Performance of Activated Carbon Sorbent	13
6	NO _x Sorption Performance Versus Temperature for Four Carbon Materials	14
7	Results of Recycling Runs with Calgon	15
8	NO _x Removals as a Function of Bed Thickness with Constant Flow	16
9	Reductions in NO ₂ , NO and CO that Occurred When a Simulated Exhaust Gas Passed Through a Vermiculite Bed at Various Temperatures	22
10	Reductions in NO ₂ , NO and CO that Occurred When a Second Simulated Exhaust Gas Passed Through a Vermiculite Bed at Various Temperatures	23
11	Effects of O ₂ Level of an Exhaust Gas on CO Removal as a Function of Temperature	24
12	Photograph of Mobile Filter Cart	28
13	Mobile Filter Cart Design	28
14	Exhaust Gas Flow Rate as a Function of Operating Load for a 72 kW AGE	30
15	Particulate Sampling Device	30
16	Collecting Data on Filter Cart Performance at Youngstown ARB	32
17	Filter Cart Testing on an AGE Unit near the Flight Line at McClellan AFB	32
18	Sorbent Regeneration and NO _x -Destruction Process	36
19	Average NO _x Removals with the Mobile Filter Cart	38
20	Laboratory Testing of a Regeneration-in-Place System	41
21	NO _x Destructor	41

LIST OF FIGURES (continued)

Figure	Title	Page
22	Stationary Diesel Engines at McClellan AFB	46
23	Exhaust-Gas Line Leading to the Mobile Filter Cart	48
24	Recycling Diesel-Engine Exhaust Gases	49
25	Conversion of NO to NO ₂ with a Stationary Carbon Bed	50
26	The Performance of Penn State's Materials (STC/950 & STC/500) in Comparison with Untreated Carbons	51
27	NO-to-NO ₂ Conversion at 700°F with a Special Oxidation Catalyst	52
28	The Effects of Ozone:NO Ratio on NO-to-NO ₂ Conversion Efficiency	53
29	Conducting a Test Run with the PDU Spray Tower	55
30	Sketch of the Laboratory PDU Scrubbing System	56
31	NO _x Removals with the PDU Spray Tower Using a NaSH Additive with a Projection for 100 Percent NO ₂ Removal	59
32	NO _x Levels of Exhaust Gases Entering and Leaving Sorbtech's NO _x Scrubber in Laboratory Tests	60
33	Recording Measurements During a Stationary Diesel-Engine Run with the Mobile Filter Cart	61
34	The Appearance of the Prefilter Before and After the Stationary Diesel-Engine Run	62
35	Bus at McClellan AFB Employed in Studies	67
36	Diesel Truck Employed in Studies	67
37	Baseline Data Obtained for a McClellan AFB Bus	69
38	The Converter Technologies Filter Trap Installed Beneath the Bus	70
39	Installing the NO _x Filters on a Bus at McClellan AFB	70
40	Conditions Observed During the Normal Operation of a Diesel Truck	73
41	Small-Particle Filter for Diesel Truck Studies	74

LIST OF FIGURES (continued)

Figure	Title	Page
42	Combined Particulates-NOx Control System as Applied to a Diesel Truck	75
43	Flow Diagram for Incinerator Slipstream Tests	78
44	Employing the Portable Filter-Bed Test Apparatus on a Slipstream of Incinerator Exhaust Gas	80

LIST OF TABLES

Table	Title	Page
1	DATA COLLECTED ON SPACE-RAY TUBE HEATERS	6
2	ESTIMATED CAPITAL AND OPERATING COSTS - RADIANT-TUBE HEATER FILTER	10
3	EFFECTS OF CHANGES IN METHANE:NO _x RATIO AND TEMPERATURE ON NO _x DESTRUCTION	18
4	LATER NO _x -DESTRUCTION TEST RESULTS	19
5	EFFECTS OF OXYGEN CONCENTRATION ON NO _x DESTRUCTION	19
6	NO _x DESTRUCTION WITH A PROTOTECH CATALYST AT VARIOUS TEMPERATURES WITH HEXANE OR METHANE	20
7	RESULTS OF ENVIRONMENTAL TESTS PERFORMED ON VERMICULITE-SILICA PREFILTER WASTE MATERIALS	26
8	AVERAGE NO _x REMOVALS DURING FOUR-HOUR RUNS WITH THE MOBILE FILTER CART	37
9	ANALYSIS OF CONDENSATE COLLECTED DURING A SHAKEDOWN RUN	38
10	EFFECTS OF TEMPERATURE AND OXYGEN CONCENTRATION ON NO _x -DESTRUCTION PERFORMANCE	40
11	THE RESULTS OF LARGE-SCALE REGENERATION-IN-PLACE WITH NO _x -DESTRUCTION EXPERIMENTS	40
12	ESTIMATED CAPITAL AND OPERATING COSTS - FILTER CART/NO _x DESTRUCTION	44
13	NO-TO-NO ₂ CONVERSION EFFICIENCY WITH AN OXIDATION CATALYST AT VARIOUS TEMPERATURES	52
14	INITIAL SCRUBBING TEST RESULTS	54
15	ADDITIONAL SCRUBBING TEST RESULTS	57
16	AVERAGE NO _x REMOVALS DURING STATIONARY DIESEL-ENGINE TESTS	61
17	RESULTS OBSERVED IN RECYCLING DIESEL-ENGINE EXHAUST GASES	62
18	ESTIMATED CAPITAL AND OPERATING COSTS - NO-TO-NO ₂ CONVERSION WITH WET SCRUBBING	64
19	SUMMARY OF BUS NO _x -FILTER TESTS	71

LIST OF TABLES

Table	Title	Page
20	NO _x REMOVALS IN TRUCK TESTS	76
21	TYPICAL INCINERATOR EXHAUST GAS CONDITIONS	78
22	INCINERATOR EXHAUST-GAS FILTER TEST RESULTS	80

APPENDICES

Appendix	Title	Page
A-1	TYPICAL LABORATORY DATA COLLECTED WITH THE HEATER FILTER	86
A-2	FIELD DATA COLLECTED WITH THE HEATER FILTER	87
A-3	MOBILE DIESEL GENERATOR EXHAUST DATA - BASELINE	88
A-4	STATIONARY DIESEL-ENGINE EXHAUST GAS DATA - BASELINE	89
A-5	ADDITIONAL SCRUBBING TEST RESULTS	90
A-6	BUS EXHAUST DATA - BASELINE	91
A-7	INCINERATOR DATA - BASELINE	92

CONTROLLING COMBUSTION-SOURCE NO_x EMISSIONS AT AIR FORCE SITES

I. INTRODUCTION

The U.S. Air Force employs many different combustion sources at its facilities around the world. These sources include boilers, burners, diesel engines, aircraft engines, turbines, incinerators, and motor vehicles. Most sources produce exhaust gases that contain some undesirable components. Components of concern in recent years are nitrogen oxides (NO_x), carbon monoxide (CO), PM-10 and PM-2.5 particulate matter, sulfur dioxide (SO₂), and a long list of components considered toxic by nature.

A. OBJECTIVE

The objectives of the project herein described were to examine potential NO_x problems at McClellan AFB in California, and, where problems could arise, to develop and demonstrate candidate solutions. The work centered on radiant-tube heaters, mobile diesel generators, stationary diesel generators, diesel buses and trucks, incinerators, and natural-gas-fired boilers. Work on jet-engine-test-cell (JETC) exhaust gases was addressed and reported in a separate study.^[1]

Control methods normally employed to reduce NO_x include modifying the combustion process, cleaning the exhaust gases, or a combination of both. An objective of the project was to examine gas-cleaning methods. With the exception of a series of experiments in which exhaust gases were recycled back to a stationary diesel engine, all work in the project was concentrated on cleaning the exhaust gases. No efforts were made to modify the combustor, the fuel, or the fuel air mixture.

B. BACKGROUND

1. THE NO_x PROBLEM

Of the undesirable components in combustion exhaust gases, NO_x stands out as one of the most difficult to control. Increased attention has been given to NO_x and to the role it plays in acid rain, smog, ozone depletion, and impacts on human health. This has led to regulations on NO_x emissions. The Federal Clean Air Act Amendments have set tough, new standards for NO_x nonattainment areas, many of which include Air Force sites. Some states, such as California, have promulgated pollutant standards that are even tougher than Federal statutes.

NO_x produced during combustion is principally NO, plus a small percentage, normally less than 10 percent, NO₂. The amount of NO_x formed during combustion depends on the characteristics of the fuel being burned and on the combustion conditions. Important parameters include the combustion temperature, the level of excess air, and the nitrogen and volatile contents of the fuel. Different combustion systems generally produce different levels of NO_x emissions.

Environmental regulations and emission limits often make it difficult for the Air Force to add needed new facilities that generate emissions. Sometimes the only way new facilities can be added is if undesirable emissions of older facilities are reduced or if special credits are purchased [if they are available to be purchased]. Reducing the levels of NOx and other pollutants at specific Air Force sites can provide valuable credits for the sites. This is particularly important for locations such as McClellan AFB, California, which is in a nonattainment area.

It is unfortunate that, in many cases, simple, low-cost methods are not available to adequately control many of the pollutants of concern. Some people believe that the best commercially available exhaust-gas treatment technology to reduce NOx emissions today is selective catalytic reduction (SCR). However, SCR is very expensive, is limited to certain temperature ranges, is only partially effective in reducing NOx, and requires ammonia additions to the exhaust gas that often slips into the atmosphere. A definite need exists today for simpler, less-costly technologies to control NOx in exhaust gases.

2. NOx-CONTROL CONCEPTS

Two gas-cleaning NOx-control concepts were developed and studied in the project. Both concepts showed a high degree of promise. The first concept is based on capturing NOx (NO and NO₂) from the exhaust gas with a sorbent and then later desorbing and destroying the NOx while regenerating the sorbent. The second concept is based on the conversion of all NOx species in the exhaust gas to NO₂ and scrubbing the NO₂ from the stream. The first concept appears suitable for all Air Force applications; the second appears best for large stationary applications.

In past work, Sorbtech engineers screened many different materials as potential NOx sorbents. Generally speaking, few materials demonstrated the ability to capture NO or NO₂ from NOx-containing gas streams. The exceptions were activated carbon and Magsorbent. Magsorbent is a product developed earlier by Sorbtech and is particularly effective in controlling SO₂ emissions. It consists of magnesia coated onto small expanded vermiculite or perlite particles, with the combinations given a high-temperature heat treatment. Magsorbent is not a particularly effective sorber of NOx. It will capture some NO₂, but only small amounts of NO, and only when significant moisture is present in the gas. The maximum NOx removal observed in the past with Magsorbent has been 30 percent during the treatment of a coal-burning utility flue gas. Research performed at Kent State University has indicated that removal is most likely achieved by reaction of NOx species with MgO or hydrated MgO in the Magsorbent. NOx removal with Magsorbent appears to occur over a wide temperature range. Certain activated carbons, on the other hand, are excellent NOx sorbers. However, sorption occurs only at low temperature, and removal efficiency decreases with increasing temperature.

Key to the Sorbtech system for the first concept are two filter beds that are employed in series. The first filter bed, or prefilter, is composed of vermiculite and silica, or a combination of vermiculite, silica, and Magsorbent. Magsorbent is employed in applications where fuels contain high levels of sulfur. The second filter bed, or primary filter, contains a specially prepared activated carbon.

The principal function of the prefilter used in the sorption concept is to remove particulates that are present in the exhaust gases. The prefilter performs this function well. In addition to particulates, it also captures some SO₂, organic compounds, and NOx. The principal NOx-capture medium, however, is the activated carbon bed, which also removes many hydrocarbon gases.

Over a period of several years, Sorbtech engineers examined more than 100 different activated carbons, many having been given special treatments. The carbon employed in the Sorbtech system was observed in the laboratory to capture typically from 7 to 15 percent of its weight in NO_x before it becomes totally saturated. After the carbon becomes saturated, it can be regenerated by simple heating and can be reused many times without a marked reduction in NO_x-capture performance.

The effectiveness of the proprietary activated carbon in capturing NO_x was observed to be influenced by temperature. Optimal NO_x-capture performance occurs when the temperatures of the exhaust gases are below 150°F. Generally speaking, the lower the gas temperature, the better is the performance. Other process variables can also affect the performance of the primary filter-bed material. The face velocity of the exhaust gases, for example, can have a significant effect on performance. Good NO_x capture occurs with face velocities of 2 feet per second or less for beds of 6 inches or more in thickness. Gaseous water will generally pass through the filter beds, but large liquid-water droplets, if present, can deposit on the carbon particles and markedly impair their performance.

Keys to the Sorbtech system for the second concept are (1) an effective means to convert NO into NO₂ and (2) an effective washing solution that reacts with and removes essentially all NO₂ from the exhaust gases. This report describes several approaches developed by Sorbtech engineers to convert NO to NO₂ and to wash the resulting NO₂ from the exhaust gases.

C. SCOPE

This is the final technical report describing a Phase II SBIR program that was supported by the Strategic Environmental Research and Development Program (SERDP). Developmental bench-test and pilot-test results are presented for a new technology that was examined for five Air Force applications. Field-test results then are reported for each of these applications. Cost estimates are provided for three applications.

II. RADIANT TUBE HEATERS

A. BACKGROUND

McClellan AFB employs natural-gas-fired radiant tube heaters to assist in drying paint applied to aircraft. Paint-drying is carried out in a large, open building shown in Figure 1. The radiant tube heaters are suspended from the ceiling of the building. A sketch of two typical heaters appear in Figure 2. The manufacturer of the heaters was the Space Ray Division of Gas-Fired Products, Inc. of Charlotte, North Carolina. More than 40 radiant tube heaters, each approximately 10 feet long and 3 feet wide, are employed in the building. Recent compliance tests on the heaters, conducted by an outside contractor, Acurex, showed levels of NO_x that were slightly higher than allowed by California environmental regulations. As a consequence, McClellan AFB has stopped using the units.

According to the outside contractor's data, if a system could be developed to reduce NO_x levels by only 10 percent, then compliance requirements for the heaters could be met. Results obtained by Sorbtech in the past with its sorbent materials suggested that a simple, low-cost unit or system could be developed to achieve the desired results.

B. APPROACH AND RESULTS

To determine the severity of the problem and to evaluate a potential sorbent-filter solution, the following activities were planned and conducted

1. Characterization of the actual heater exhaust gases to verify the problem.
 2. Design of a full-scale prototype filter unit to reduce NO_x levels.
 3. Construction and testing of the unit with actual heater exhaust gases.
 4. Determination of the level of improvements that might be expected with the new unit under different conditions.
1. Exhaust Gas Characterizations

A team of Sorbtech engineers was dispatched to the paint-drying building at McClellan AFB to characterize the heater exhaust gases, particularly as to compositions, temperatures, and flow rates. The heaters were not in use at the time of the team's arrival. In fact, the heaters had not been turned on for over a year, since the time of the outside consultant's studies. During Sorbtech's visit, the McClellan AFB workers, moreover, found it impossible to manipulate the valves to allow gas to flow to the burners. They tried to ignite the burners on several occasions during a two-day visit with no luck. Reluctantly, the Sorbtech engineers were forced to make alternate plans.

The alternate plans included contacting the manufacturer about the possibility of testing a similar unit at its facilities. Fortunately, the manufacturer had on hand a radiant tube heater of similar design, which was installed especially for test purposes. The manufacturer agreed to allow Sorbtech to characterize the exhaust gases from this unit.

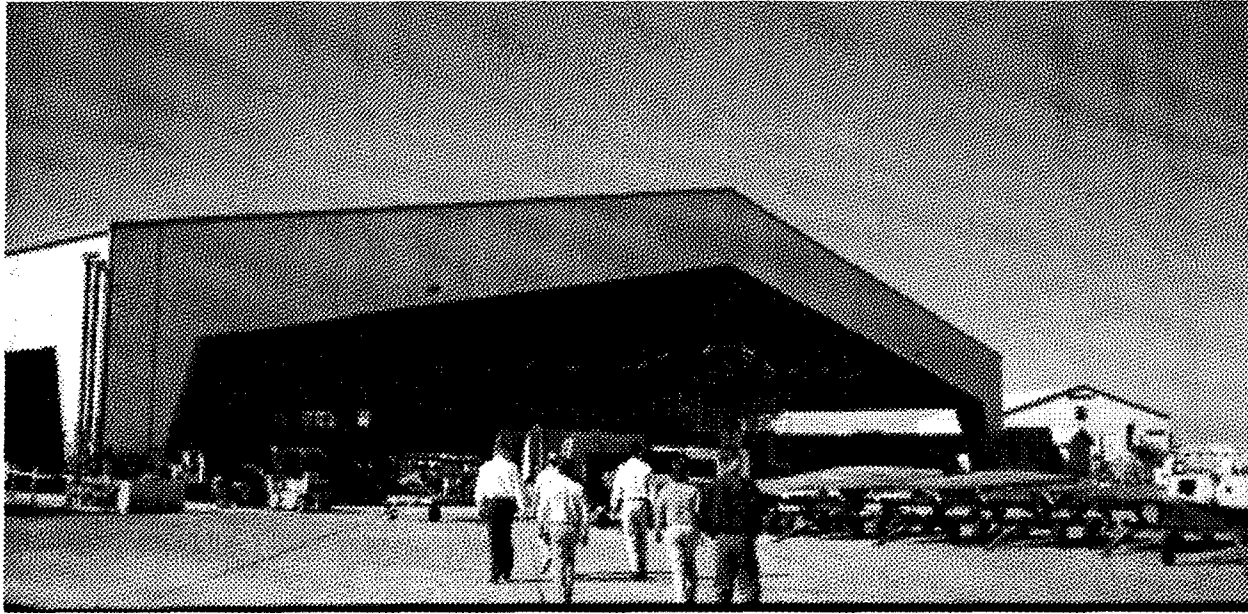

Figure 1. Aircraft Repainting Facility
at McClellan AFB

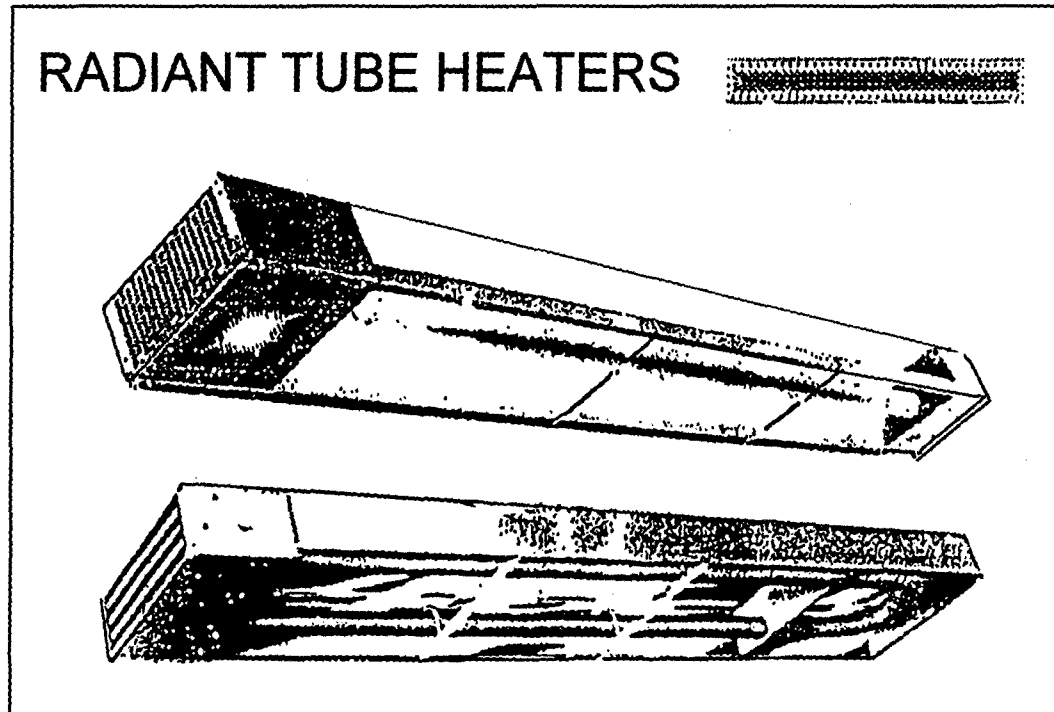

Figure 2. A Sketch of Radiant Tube Heaters

Data collected by Acurex and characterization measurements made at Space Ray's facilities are summarized in Table 1. An Enerac 2000E portable gas analyzer was employed by Sorbtech to determine gas compositions. Conventional chromel-alumel thermocouples were used to monitor temperatures. A Kurz hot-wire anemometer was used to measure gas velocities. Unfortunately, gas temperatures were too high to record accurate velocities with the anemometer, and therefore gas flow rates were not calculated. Acurex reported a gas flow rate of 93 DSCFM.

2. Design, Construction, and Testing of a Prototype Filter Unit

Several guidelines were adopted in designing a suitable filter unit for the radiant tube heaters. These guidelines included:

- Each heater should have its own filter.
- The filter should be relatively small in size.
- The filter should be placed away from the radiant tubes and preferably out of sight from the ground.
- The filter should be readily serviceable (easily replaced).
- The filter should have as long a life as possible, before replacement is required.

TABLE 1. DATA COLLECTED ON SPACE-RAY TUBE HEATERS

<u>Corporation</u>	<u>Acurex</u>	<u>Sorbent Technologies</u>	
		Sleeve open	Sleeve closed
Gas Temp., °F	490	556	737
Moisture, vol %	6.6	6.6	6.6
O ₂ , vol %	15.2	16.0	14.7
CO ₂ , vol %	3.2	3.3	5.1
CO, ppm	<1	3	0
NO _x , ppm	27	19	25
NO _x , ppm corrected to 3% O ₂	85	71	72

With the above guidelines in mind, Sorbtech designed the filter prototype unit shown in Figure 3. Two materials were considered as sorbents for this filter: (1) activated carbon and (2) Magsorbents. Although activated carbon will generally provide higher NO_x-removal rates per given volume of sorbent than Magsorbent, activated carbon was ruled out because of the high temperatures (500°-750°F) of the heater exhaust gases. Magsorbent, on the other hand, can capture NO_x within this temperature range. Magsorbent therefore was selected as the sorbent for the filter.

Magsorbent has been shown in the past to be effective in removing up to 35 percent of the NO_x present in exhaust gases when placed as static beds in the exhaust gas stream. Removal efficiency has been observed to be a function of exhaust gas velocity, the bed thickness and, to a lesser degree, the exhaust gas composition. In small-scale experiments, a 1- to 2-inch bed of Magsorbent has been observed to remove 10 to 20 percent NO_x, as long as the gas velocity was low, less than 2 fps.

On the basis of the above observations, a filter of the design shown in Figure 3 was developed. The filter consisted of two parallel flat beds, each 1.5 inches thick and having a relatively large surface area. Exhaust gas was introduced between the beds and flowed upward and downward through the two beds. The filter unit was designed to be installed on top of the heater, where it would be permanently attached and held slightly above the heater, so gas would flow freely through both the top and bottom filter beds.

The prototype filter was constructed of stainless steel solid and perforated sheet metal. The latter was incorporated into the top and bottom of the filter to allow the treated gas to pass out from the filter. Two series of tests were performed on the prototype. The first series was performed at Sorbtech's laboratories in Twinsburg, Ohio, using simulated burner exhaust gases. The second series was performed at Space Ray's facilities in Charlotte, North Carolina. The set-up that was used to evaluate the performance of the filter at Space Ray's facilities is shown in Figure 4.

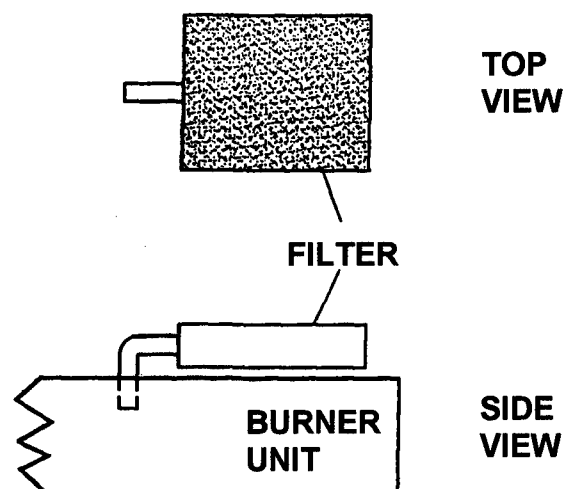

Figure 3. A Simple Rectangular Filter Design was Selected for the Heater Filter

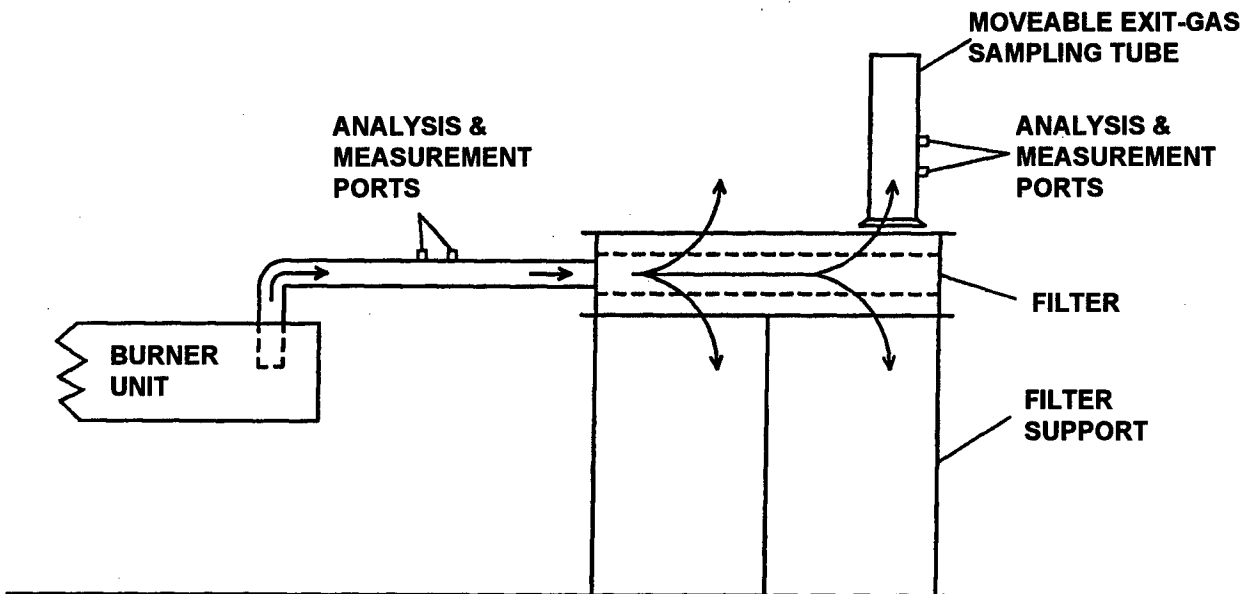

Figure 4. Filter and Equipment Arrangement for Filter Tests

3. Results of Prototype Testing

Laboratory Test Results. The prototype was initially tested in the laboratory. An exhaust gas simulating the exhaust gas expected at McClellan AFB was employed in the tests. This gas was produced with a propane burner, with gas additions made to the flue gas, as needed. The NO_x level of the gas was monitored as the gas entered and left the filter. A special portable tubular collection chamber was constructed to permit the measurement of exhaust gas exiting the filter at different locations across its surface. The filter was divided into 12 discrete sections and the temperature composition of the gas passing through each section was measured.

Typical measurements made in the laboratory are provided in Appendix A-1. The results showed that NO_x removal varied somewhat across the filter face, but was generally within a narrow range. Average NO_x removals with the new filter varied from about 17 to 25 percent. During the initial tests, it was noted that much heavier flow occurred through the top filter bed than through the bottom bed. To correct this problem, a baffle was placed inside the inlet pipe extending into the filter chamber. This baffle was observed to be very effective; flows through the top and bottom filters were nearly the same.

Field Test Results. Space Ray maintains facilities for manufacturing and assembling radiant tube heaters in Charlotte. It has on site a large room containing tube heaters for development and testing purposes. One of two units was made available to Sorbtech engineers for testing, which was performed in two parts. In the first part, the exhaust gases from the heater were characterized; in the second part, the filter was connected to the heater and its performance was evaluated.

Data collected with the unit are summarized in Appendix A-2. The results seen in the first part of testing appear to confirm Acurex's results. However, it should be noted that:

- The exhaust gas temperatures that were observed were higher than those measured by Acurex. Different measurement locations may be responsible for the differences.
- The NOx levels of the exhaust gas that were measured were slightly lower than those reported by Acurex.
- The Space Ray unit appeared to be a well-engineered unit; CO emissions levels were low or in the non-detectable range with the analysis equipment that was employed.
- The unit contained a sleeve on the exhaust gas tube that could be opened or closed. The units at McClellan AFB have sleeves in the open position. Theoretically, an open sleeve permits more dilution air to be drawn into the exhaust gas and reduces temperature. It was found, however, that a permanent second opening also exists between the internal exhaust pipe and the exit channel piece that likewise introduces dilution air, so the sleeve, although important, is not the only source of dilution air. Tests were conducted with the sleeve opened and closed. The position of the sleeve did not appear to have a significant effect on exhaust gas temperature or on NOx emissions.
- A review of AGA/CGA's data for Space Ray's new radiant tube heater (Model LTU175-N5) appeared to indicate that the new heater will meet California's NOx standards.

A major problem was observed when the filter was incorporated with the heater. The heater contained a built-in back-pressure detector that prevented ignition when there was excessive back pressure on the system. The placing of the filter on the exhaust line created a back pressure larger than could be compensated for by the burner's small fan. No ignition was possible. Fortunately, the back-pressure detector could be removed from the system, and ignition was accomplished. With the electronic device removed from the circuit, however, combustion became less controlled and excess CO and unburned carbon were produced. The performance of the filter was then evaluated under the less-than-optimal conditions. With the heater-filter combination, an average NOx removal rate of 28 percent was observed. This was in good agreement with laboratory test results.

4. Filter Costs

An estimate was made of the costs of NOx-control with the filter for the radiant tube heater. Table 2 summarizes the expected capital and operating costs for each unit, if 1,000 units were manufactured and used. Each small filter would be expected to cost about \$100. Except for sorbent removal and replacement every 2 to 3 years, maintenance and operating costs would be minimal.

The capital and operating costs were then translated into an average cost per ton of NOx removed. In this case, the total NOx-control costs were observed to be approximately \$3,500 per ton of NOx removed.

**TABLE 2. ESTIMATED CAPITAL AND OPERATING COSTS –
RADIANT-TUBE HEATER FILTER**

CAPITAL COSTS

Basis: 1000 units; Each unit contains 12.6 lb sorbent

Sorbent	\$	4,000
Steel & Other Materials		25,000
Labor & O/H		40,000
Misc. Directs		8,000
Installation		10,000
Profit		<u>11,000</u>
Total	\$	98,000 or \$98/unit

Capital Cost/Ton NOx Captured

Capital Cost Plus Financing

Capital Cost	\$	98.00
Cost of Capital (20 yr @ 6%)		<u>82.00</u>
Cost over 20 yr	\$	180.00

The filter captures approximately 0.003 lb NOx/hr. If a radiant tube heater is operated 4000 hr/yr, then each heater filter would capture 12 lb of NOx per year, or 240 lb over a 20-year period. On this basis, the

$$\text{Capital Cost Component} = \$1500/\text{T NOx Removed}$$

OPERATING COSTS

Basis: Single unit; 12 lb NOx captured annually; Sorbent replacement is required every 2.5 years.

Annual

Replacement Sorbent	\$	1.50
Replacement Labor		10.00
Sorbent Disposal		0.50
Additional Maintenance		<u>Nominal</u>
Total	\$	12.00

COST PER TON OF NOx REMOVED

Basis: 20-year life of filter structure; Sorbent replacement every 2.5 years.

Cost/T of NOx Removed

Capital Cost	\$	1,500
Operating Cost		<u>2,000</u>
Total Cost per Ton of NOx Removed	\$	3,500

5. Review of Calculations

A discovery was made in reviewing the calculations that were performed by the outside contractor who earlier evaluated the radiant tube heaters. It was observed that the contractor rounded off numbers during its calculations and, as a result, reported values higher than those considered allowable. If, on the other hand, the numbers were not rounded off, the measured values would have been lower than the allowable limits, and the heaters would have indeed met the current California standards.

C. DISCUSSION OF RESULTS

It was demonstrated that a filter device can be employed to reduce NOx emissions on radiant tube heaters. However, any filter device will present some back pressure that can affect the performance of the heaters. The Space Ray heaters currently being used appear to be particularly sensitive to back pressure. Some modifications to the heater, such as a larger-sized fan, may be required to overcome the added pressure drop presented by the filter device.

The rounding-off error that was discovered indicates that the heaters today meet regulation requirements and they need not have been turned off. It should be noted, however, that they just barely meet standards and if standards are tightened only slightly in the future, they will not meet the newer standards.

III. LABORATORY STUDIES

A. NO_x SORPTION WITH ACTIVATED CARBON

A laboratory test was developed to screen various materials for their relative performance in removing NO_x from NO_x-containing simulated flue gases. The test adopted consisted of exposing a stationary bed of the material, 0.5 inch in diameter and 8 inches long, to a gas consisting of 450 ppm NO, 50 ppm NO₂ and balance air with 10 percent oxygen, at a flow rate of 4 lpm. Initial screening tests were performed at room temperature.

The activated carbon selected for the project was obtained from Calgon Carbon Corporation. Typical performance data for this carbon as a function of exposure time are shown in Figure 5. These data indicate that NO_x removal will remain relatively constant at about 80 percent for more than 74 hours at room temperature during the laboratory test. As the gas temperature increases, however, the NO_x-removal performance of activated carbon generally decreases. This can be seen in Figure 6, which shows the performances of the Calgon material, a carbon material prepared and supplied by the Illinois State Geological Survey (ISGS), and carbon materials.

Several Chinese and Siberian activated carbons were evaluated in the project. Generally, they did not capture NO_x as well as the Calgon and ISGS materials.

The sorption, desorption and resorption ability of the activated carbon selected for the project was examined in the laboratory. A sample of carbon was taken through 10 cycles. As the data in Figure 7 show, the NO_x removal performance remained fairly constant throughout for all 10 cycles. During the initial cycles, the actual gain in weight of the sample was observed to be larger than the gain in weight expected from NO_x mass balance calculations, based on the compositions of the gases into and out from the sample. The differences observed are believed attributable to oxygen sorption. In related experiments and in experiments by others, the presence of oxygen in the flue gas stream was observed to be critical for good NO_x capture. In the absence of oxygen, NO is not sorbed. It is believed that, when oxygen is present, some oxygen is sorbed onto the carbon surfaces and NO is then sorbed as NO₂.

In addition to gas temperature, residence time in the bed appears to be an important factor affecting NO_x-capture performance. This was demonstrated clearly in a series of tests in which only the bed length was changed and all other variables were held constant (See Figure 8). Earlier tests showed that an 8-inch bed typically removed about 80 percent of the NO_x in the exhaust gas, and a 12-inch bed removed essentially 100 percent.

B. ACTIVATED CARBON REGENERATION AND NO_x DESTRUCTION

Activated carbons used to sorb NO_x from NO_x-containing exhaust gases were found to be easily regenerated (desorbed of their NO_x) and returned to their near-original condition by simple heating. Typically, 275°F is a good regeneration temperature. The NO_x species released during regeneration are generally the same as those that were sorbed. In the laboratories, released gases during regeneration contained as much as 50 percent NO_x. Other components in the released gases included CO₂ and nitrogen, the latter being an inert diluent used to transfer heat to the carbon bed and to carry the released NO_x away.

During regeneration, the released No_x is destroyed by mixing it with a reducing gas and passing the combination through a catalyst bed. In an earlier program, Sorbtech discovered a

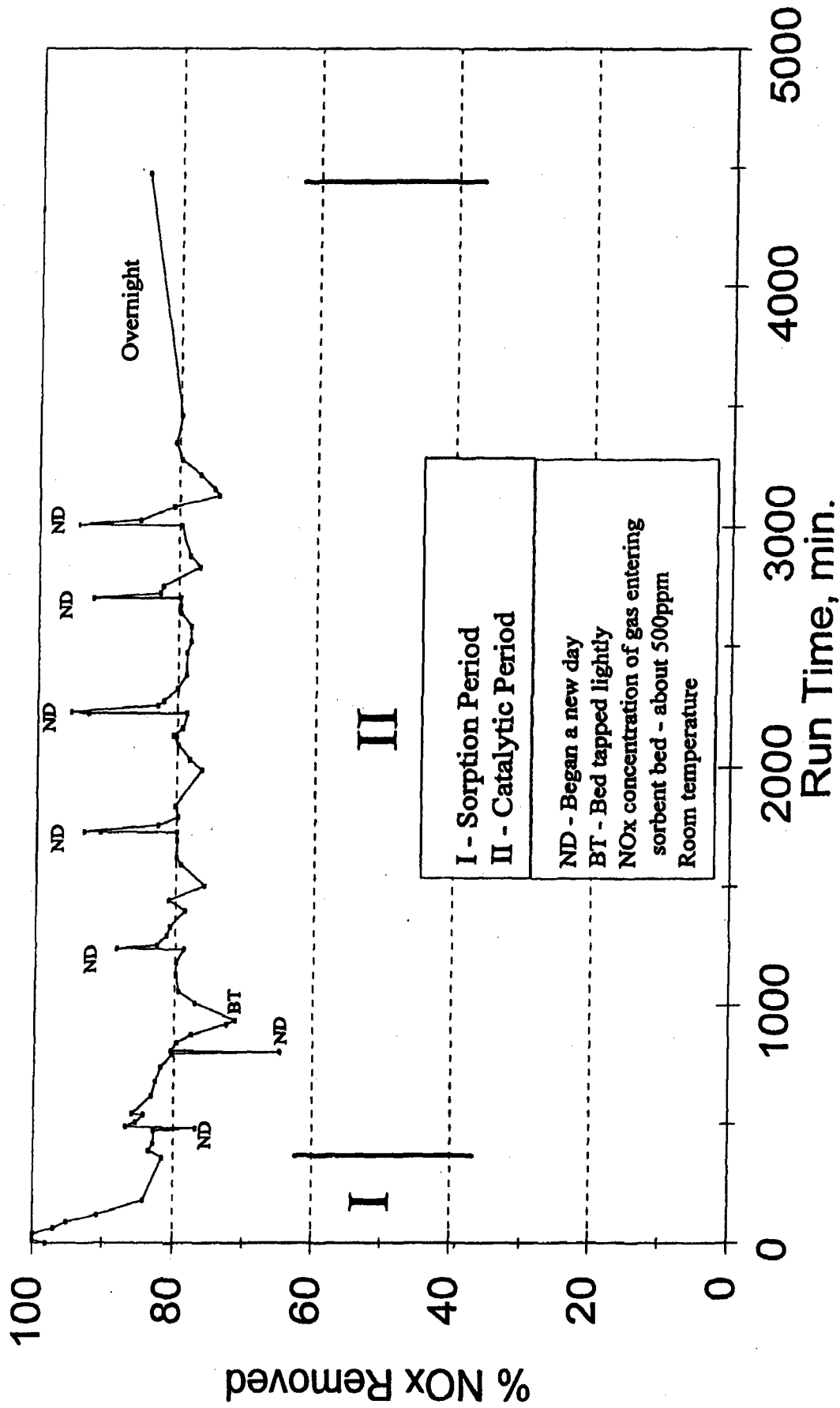

Figure 5. Performance of Activated Carbon Sorbent

Residence Time = 0.2 sec

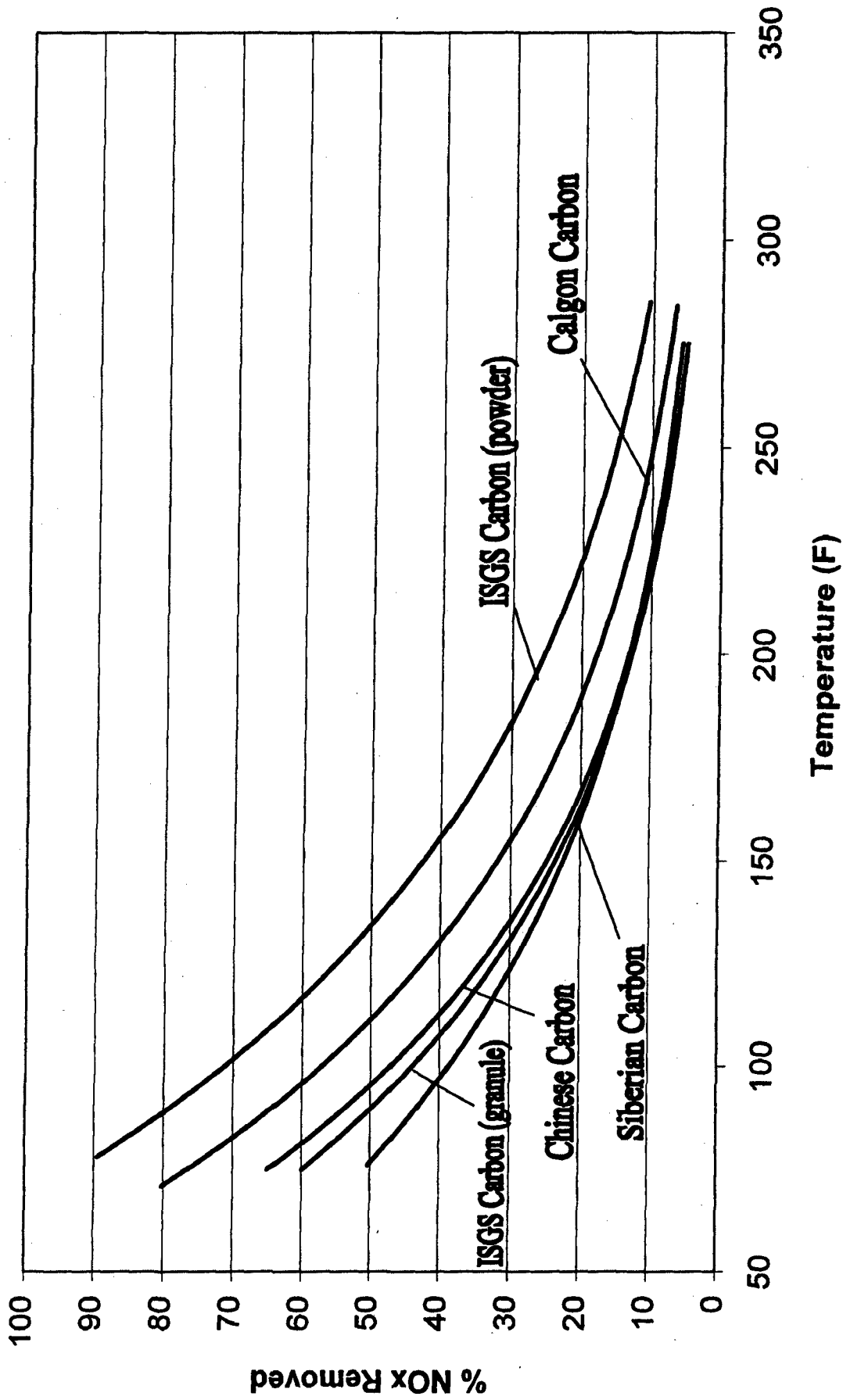
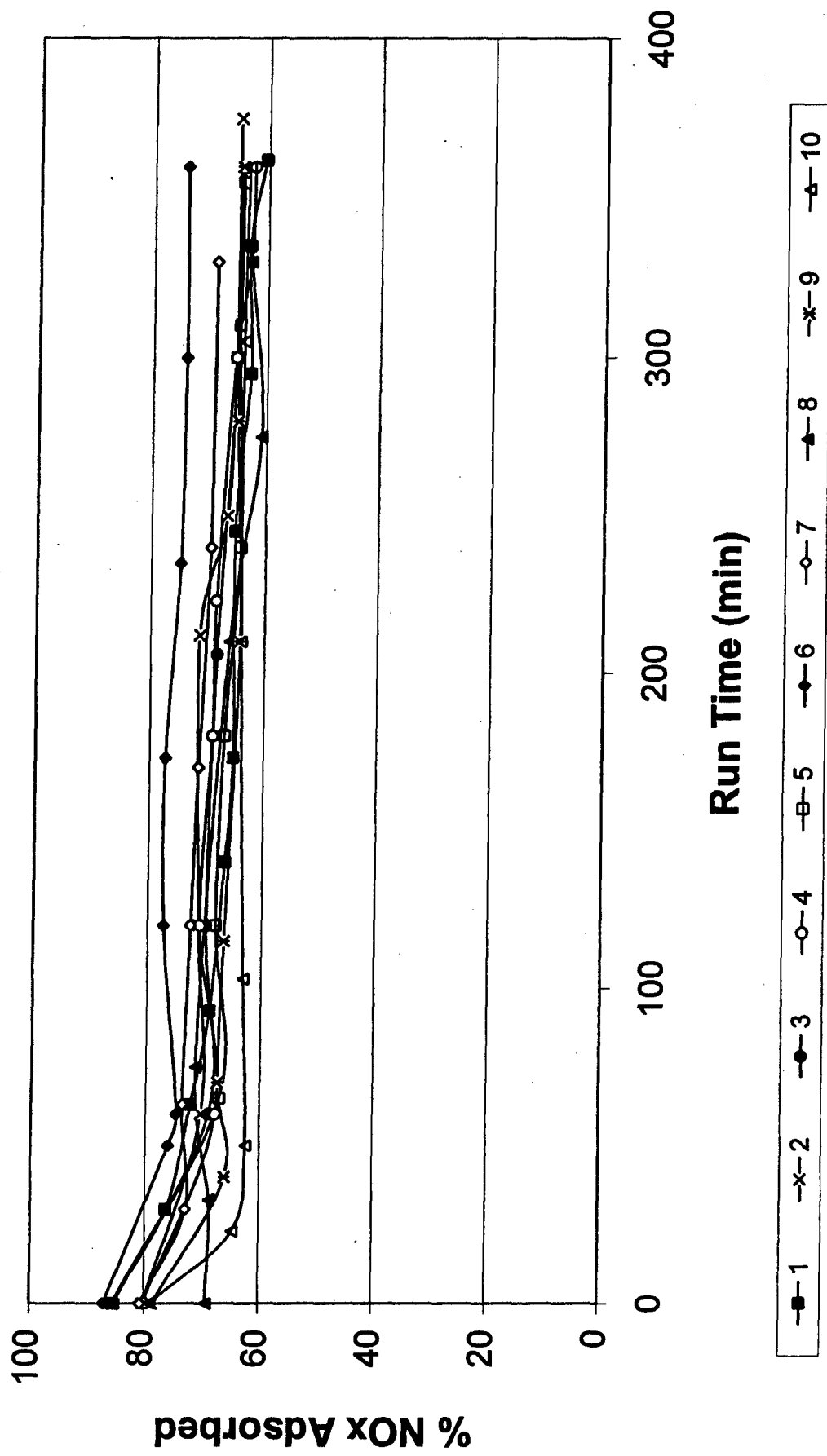

Figure 6. NOx Sorption Performance versus Temperature for Four Carbon Materials



The Cycle 6 test was run with 18.3% oxygen in the simulated exhaust gas, while all others were performed with 10.0% oxygen.

Figure 7. Results of Recycling Runs with Calgon Activated Carbon

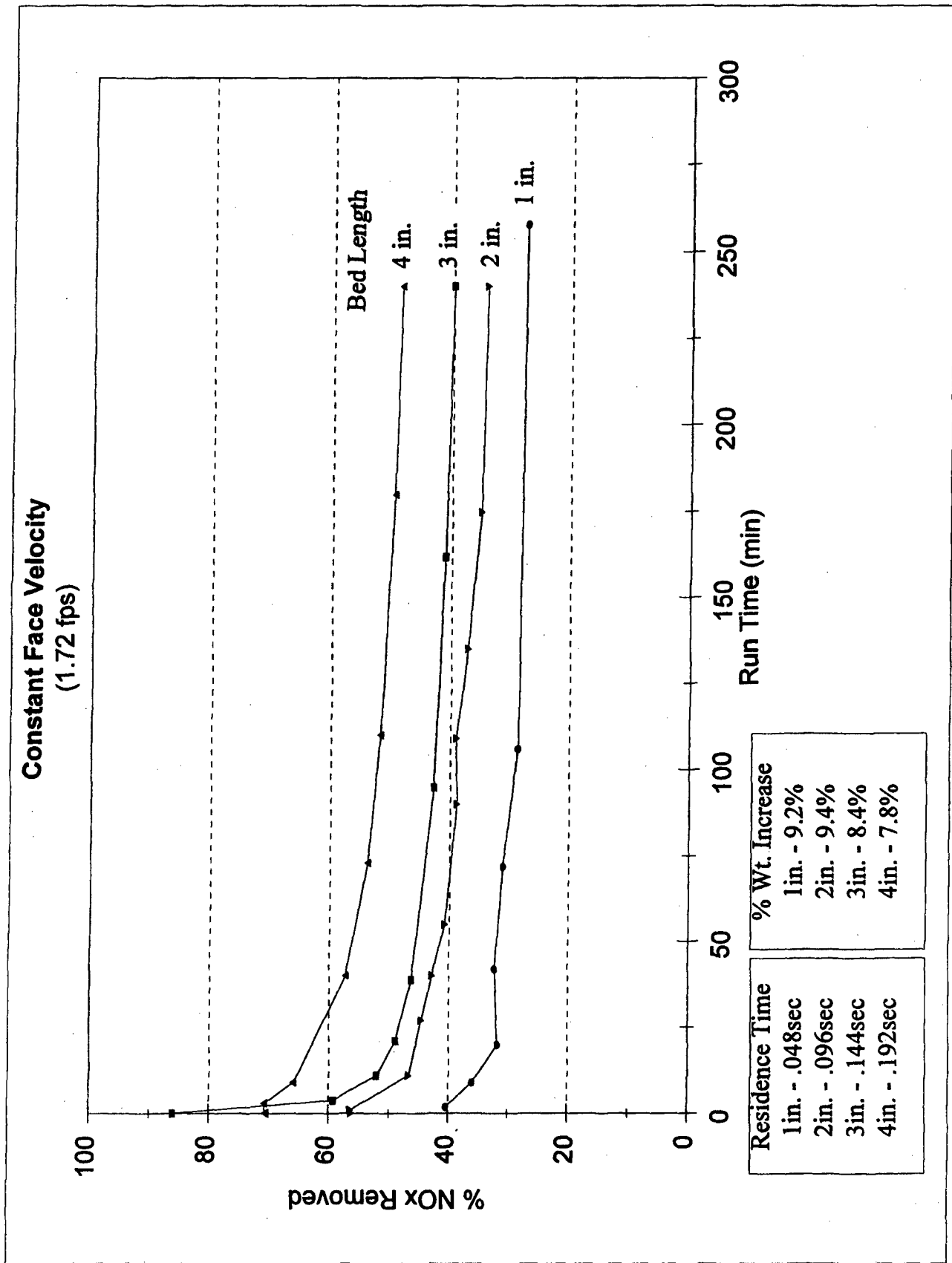

Figure 8. NOx Removals as a Function of Bed Thickness with Constant Flow

magnesium oxide catalyst that was effective in destroying concentrated NO_x streams when used in combination with methane, propane, or reformed methane.

An extensive effort was made to determine the best temperature and reducing gas:NO_x ratio that should be employed with the magnesium oxide catalyst to achieve maximum NO_x destruction. More than 20 runs were performed at different temperatures and with different ratios. Many of the early runs are summarized in Table 3. Later run results are given in Table 4.

The effect of the possible presence of oxygen in the regeneration gas on NO_x destruction was investigated in a separate series of experiments. The results of these experiments, summarized in Table 5, showed that the presence of oxygen at levels up to 4 weight percent can lower NO_x destruction efficiency, but only a minimal amount.

On the basis of the results of the laboratory test runs with methane and the new oxide catalyst, a destruction temperature in the range of 1400 to 1550°F (750 to 850°C) and a methane:NO ratio of 0.27 to 0.31:1 were selected as most appropriate for NO_x destruction. Reaction of the reducing gas with NO_x occurred rapidly as the gas passed through the catalyst bed and the reaction products were simply nitrogen, CO₂ and H₂O. Little or no residual methane occurred in the off-gases.

Mr. Scott MacKenzie of Cha Corporation reported his observation that NO_x can be destroyed at relatively low temperatures if a conventional automobile catalyst produced and supplied by Prototech (United Catalysts) is used in combination with a reducing gas. He employed JP-5 aviation fuel as the reducing gas with good success.

A sample of catalyst was acquired from Prototech, and several laboratory experiments were performed on NO_x-containing off-gases liberated during the regeneration of NO_x-saturated activated carbon. Two different reducing gases were examined, methane and hexane. NO_x destruction as a function of temperature was determined for each reducing gas. The results of these experiments are summarized in Table 6.

With the Prototech catalyst, little or no NO_x destruction occurred with the methane reducing gas at temperatures below 1200°F. Essentially 100 percent destruction, however, occurred with hexane at temperatures below 700°F with a near oxygen-free gas. For good destruction at low temperatures, a carbon-based reducing gas having carbon values of 5 or above appeared most desirable. On the basis of the laboratory tests performed by Sorbtech, hexane and the Prototech catalyst can be used for destruction at a temperature near 700°F, with a hexane:NO ratio of 0.21 and in the absence of oxygen. The presence of oxygen was observed to destroy the reactions. With a NO_x-rich gas having 0.6 percent oxygen, no NO_x destruction occurred. Because regeneration gases invariably will contain some oxygen, the use of hexane and the Prototech catalyst was judged impractical.

TABLE 3. EFFECTS OF CHANGES IN METHANE:NO_x RATIO
AND TEMPERATURE ON NO_x DESTRUCTION

<u>Run No.</u>	<u>CH₄:NO Ratio</u>	<u>Temperature (°C)</u>	<u>NO_x Destroyed (%)</u>
1	20.0	700	61
2	12.1	750	98
3	4.0	800	100
4	4.0	800	100
5	2.3	800	96
6	0.9	800	82
7	0.9	850	99
8	0.8	850	97
9	0.9	800	85
10	1.1	800	89
11	1.5	800	93
12	1.5	770	79
13	1.1	770	72
14	0.7	725	45
15	0.7	810	77
16	3.2	800	99+
17	2.2	800	96
18	0.73	800	99
19	0.65	800	98
20	0.73	750	100
21	0.36	775	100
22	0.30	750	96
23	0.36	100	0
24	0.36	350	0
25	0.36	600	0
26	0.36	700	0
27	0.36	750	99
28	0.36	800	99

TABLE 4. LATER NO_x-DESTRUCTION TEST RESULTS

CH ₄ :NO	Temp. (C)	NO _x Destroyed
0.27:1	800	89.0
0.30:1	750	96.1
0.31:1	850	99.9
0.36:1	775	99.7
0.73:1	750	99.9

TABLE 5. EFFECTS OF OXYGEN CONCENTRATION ON NO_x DESTRUCTION

CH₄:NO = 0.30
Space Velocity = 1200 hr⁻¹
Temperature = 800°C

% Oxygen	NO _x Destroyed
0.0	99.0
1.0	98.6
2.0	98.8
4.0	97.9

CH₄:NO = 0.15
Space Velocity = 1200 hr⁻¹
Temperature = 800°C

% Oxygen	NO _x Destroyed
1.1	86.2
2.2	86.0
3.1	84.9

**TABLE 6. NO_x DESTRUCTION WITH A PROTOTECH CATALYST
AT VARIOUS TEMPERATURES WITH HEXANE OR METHANE**

Reducing Gas	Temperature (F)	Oxygen Level	NO _x Destruction
Methane	700	0.0%	0%
Methane	900	0.0%	0%
Methane	1100	0.0%	0%
Methane	1200	0.0%	100%
Hexane	500	0.0%	30%
Hexane	600	0.0%	99%
Hexane	700	0.0%	100%
Hexane	650	0.6%	0%

C. PREFILTER STUDIES

Particulates are a problem component of many exhaust-gas streams. Diesel and jet-fueled combustors emit particulates that are especially difficult to capture. They tend to be small in size, high in carbon, and often liquid or semi-liquid in form. In earlier studies, Sorbtech engineers discovered that expanded vermiculite was a good capture medium for diesel and jet engine particulates, particularly vermiculite when used in combination with silica fibers. Both the vermiculite particles and silica fibers appear to hold static-electrical charges on their surfaces that attract fine particles. Several series of small laboratory experiments were performed that demonstrated that up to 100 percent of the particles, particularly particles in the 0.2- to 1.2-micron range, could be captured from simulated exhaust gases with the materials.

The laboratory research work culminated in a 50-hour test run on a vertical filter of the materials. The filter was placed in the exhaust gas line of a diesel truck, replacing the existing muffler. The truck that was employed, a well-used, vintage White Motors Road Boss 2, was a "smoker." In preliminary tests with this truck, high levels of smoky particulates were generated and released to the atmosphere when the truck's engine was running at idle. Particulate emissions appeared to become less evident as the engine speed was increased and the engine produced a hotter gas. The particulate-capture bed consisted of 2 inches of expanded, coarse-grade vermiculite faced with 0.05-inch sheets of bonded silica fibers. It had a total exposed surface area of 20 square feet. During more than 95 percent of the test time, the engine was run at idle; at other times, the engine was operated at high engine speeds. Observations that were made during the run included:

- (1) The filter appeared to perform as well as, if not better than, the original muffler in reducing noise levels.
- (2) Particulate capture was good both at idle and at high engine speed.
- (3) The capture rate of particulates (particles 0.2 microns or larger) with the new filters was 90 percent or more during the initial hours of usage; however, the rate fell off to 80 percent or lower after 50 hours.
- (4) The filter apparatus at idle presented very little pressure drop. Initially, the pressure drop was 0.1 inch W.G. After 50 hours of particulates' collection, the pressure drop increased to approximately 1.0 inch W.G.
- (5) The filter apparatus was designed to be easily opened and examined during the test runs. Surprisingly little particle deposition occurred on non-filter surfaces during the run. The filter faces, on the other hand, became progressively blacker in color as run-time increased.

D. STUDIES AT PENNSYLVANIA STATE UNIVERSITY

In earlier studies, it was noted that exposure to expanded vermiculite itself could result in a reduction in the NO_x level of an exhaust gas if CO was also present in the gas. The vermiculite appeared to act as a catalyst promoting the reactions:

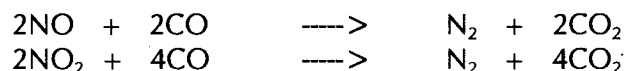

A research study was performed at Pennsylvania State University examining the effectiveness of vermiculite in promoting these reactions. Some examples of the data collected in this study are shown in Figure 9, 10, and 11.

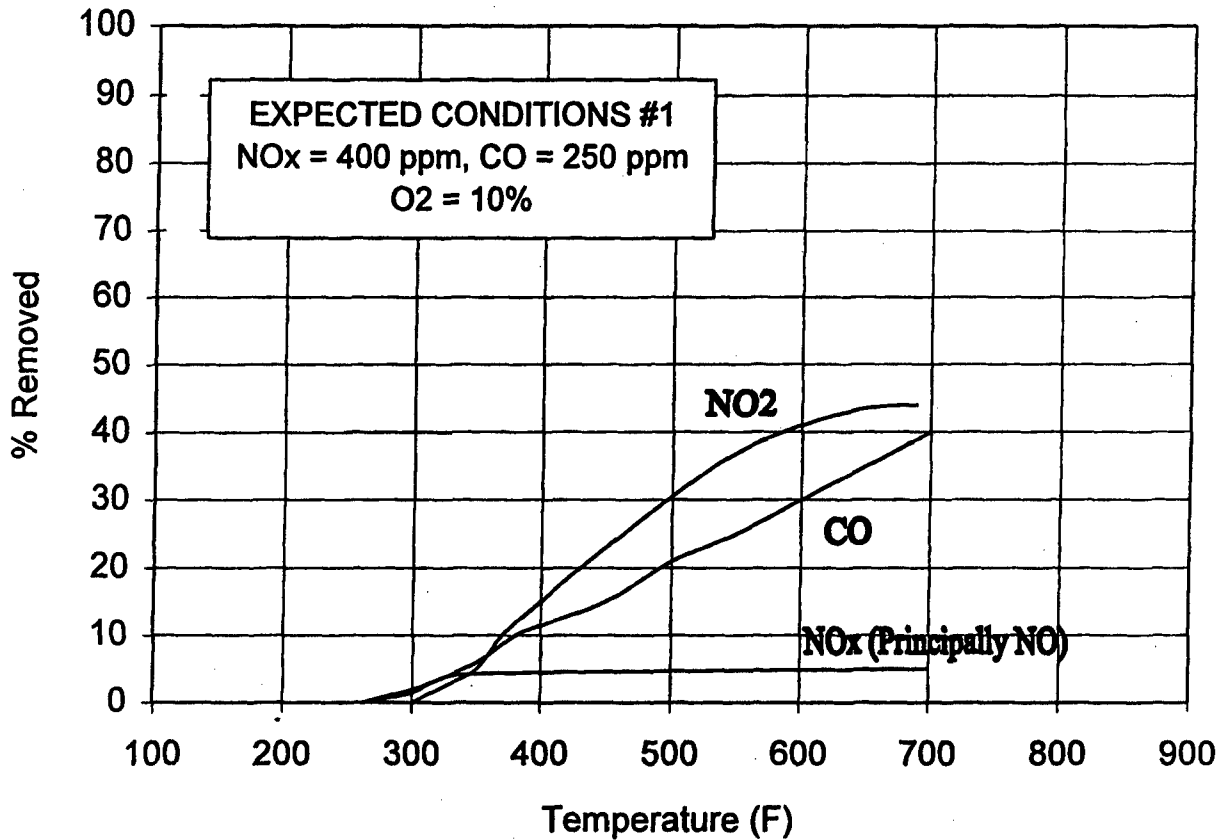

Conditions: Feed gas was argon with 3% CO₂ and NO_x, CO, and O₂ levels as indicated above. Gas flow rate was 4 l/min and space velocity was 8000 hr⁻¹. Vermiculite bed size was 30 cc.

Figure 9. Reductions in NO₂, NO and CO that Occurred When a Simulated Exhaust Gas Passed Through a Vermiculite Bed at Various Temperatures.

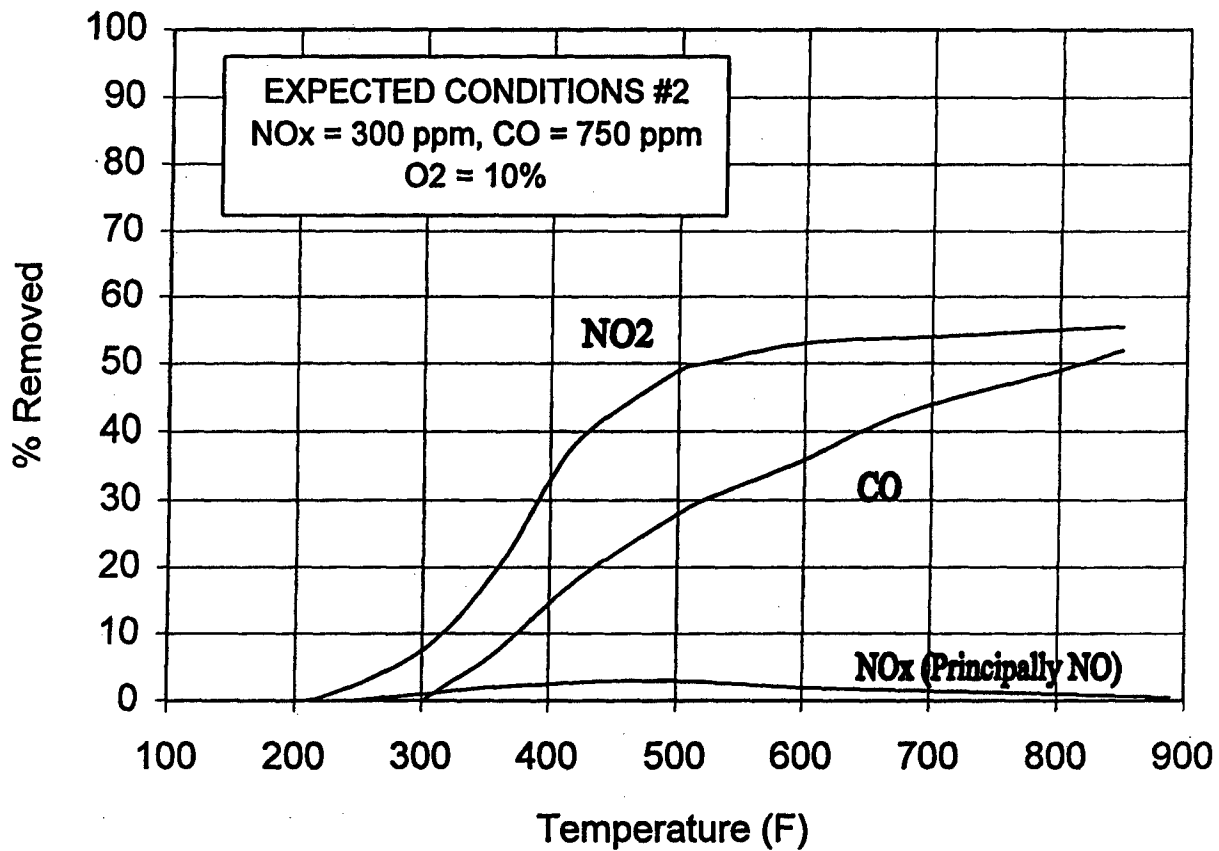

Conditions: Similar to those described in Figure 9, except the feed gas contained the NO_x, CO and O₂ levels that are indicated.

Figure 10. Reductions in NO₂, NO and CO that Occurred When a Second Simulated Exhaust Gas Passed Through a Vermiculite Bed at Various Temperatures

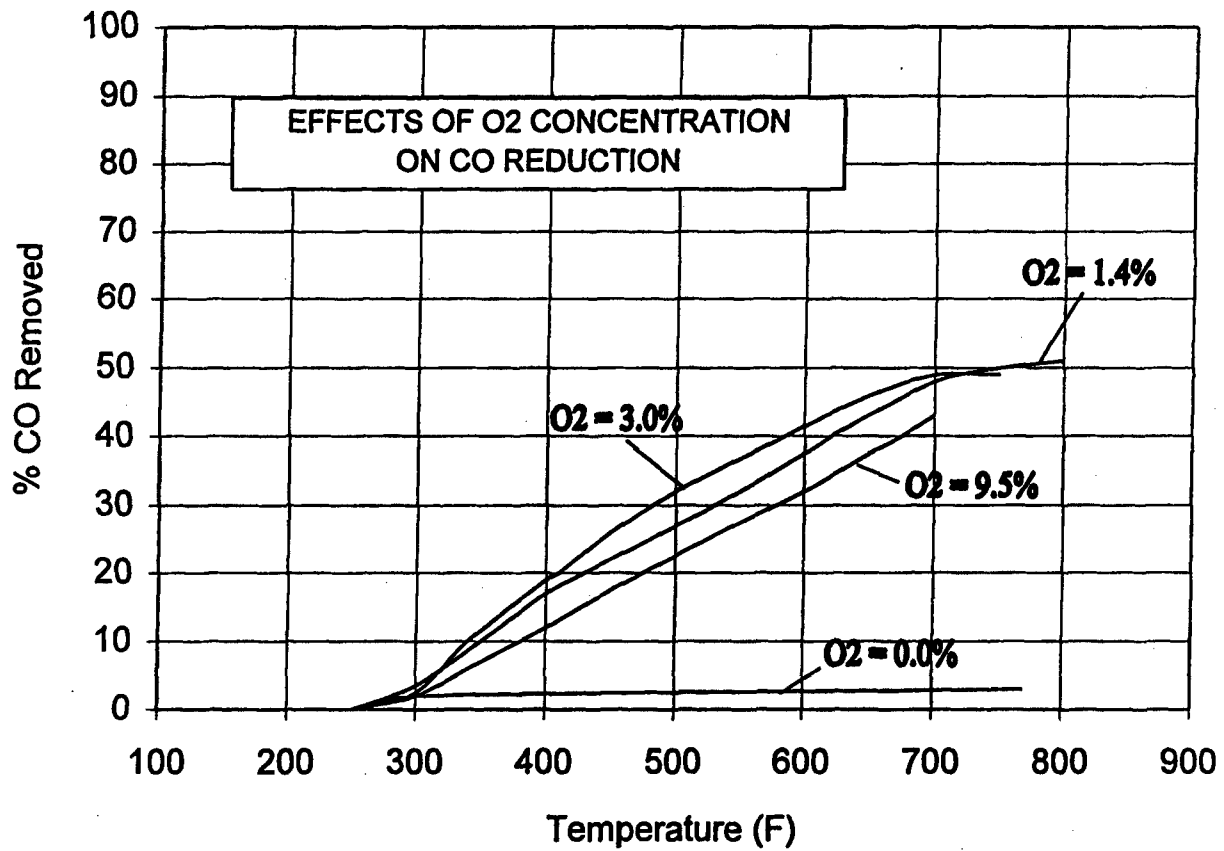

Figure 11. Effects of O₂ Level of an Exhaust Gas on CO Removal as a Function of Temperature

The results of the study showed that exposure to vermiculite can indeed reduce the level of NO_x in a NO_x-containing gas stream, but the reductions are limited to the NO₂ species. Little or no reduction of NO, the principal species of most exhaust gases, occurred. Also, the reductions that occurred were strongly dependent on gas velocity, on gas temperature, and on the amount of CO and oxygen in the gas. In the absence of oxygen, essentially no reduction occurred.

E. DISPOSAL OF FILTER WASTES

The materials employed in Sorbtech's filters are activated carbon, Magsorbent, and vermiculite-silica combinations. The activated carbon and Magsorbent materials are regenerable and recyclable. However, even being recyclable, they will eventually degrade and require replacement, at least in part. This means some material must eventually be disposed of. Several options exist. These include:

- (1) Returning the material to the manufacture for reprocessing;
- (2) Incineration; and
- (3) Land disposal.

Returning activated carbon to the manufacturer is an attractive option. Manufacturers, such as Calgon Carbon Corporation, will accept used carbons as long as the condition of the carbons is such that they can be reprocessed satisfactorily. Acceptability is handled on a case-by-case basis. Manufacturers, however, will generally not pay for used carbons nor even cover the costs of transporting them to their facilities.

Other options for activated carbon wastes include burning and landfill. Activated carbon can be an excellent fuel. It can be used as a supplemental fuel for solid-fuel furnaces, such as coal combustors or incinerators. Burning or incineration is the most direct approach for disposing of waste activated carbons. Land disposal, on the other hand, is probably a less desirable approach. Activated carbon's ability to sorb and release organic compounds, many of them highly toxic, makes land disposal a risky option.

The possibility of land disposal for Magsorbent, on the other hand, has been examined by Sorbtech and by the Ohio Agricultural Research and Development Center. Magsorbent materials employed to treat coal-fired utility flue gases demonstrated no adverse effects in being mixed with agricultural low-quality soils and, in fact, promoted plant growth. EPA Leachability tests on used Magsorbent showed no harmful releases of heavy metals.^[2] Incineration is probably not an appropriate choice for Magsorbent because the vast majority of the material is non-combustible. Like incineration, return to the manufacturer for reprocessing is probably not a realistic option.

The vermiculite and silica materials used in the prefilters require special attention because of their relatively low costs. Owing to these low costs, vermiculite and silica materials are best used only once and then disposed of. Vermiculite and silica, like Magsorbent, however, are non-combustible, and therefore incineration is not a good option. Return-to-the-manufacturer is an option that requires additional study. Landfill, therefore, appears to be the simplest option. To explore this option, Sorbtech employed an outside environmental laboratory (NSL Analytical Services, Inc., of Cleveland, Ohio) to perform a TCLP analysis on a sample of vermiculite-silica material that was exposed in a 50-hour diesel truck test. The diesel truck test will be described later in this report. The results of the TCLP analyses, provided in Table 7, show that the used vermiculite and silica materials are not classifiable as a hazardous waste and should be disposable as a normal waste.

**TABLE 7. RESULTS OF ENVIRONMENTAL TESTS PERFORMED
ON VERMICULITE-SILICA PREFILTER WASTE MATERIALS**

Volatiles				
<u>Analyte</u>	<u>Results (mg/L)</u>	<u>Estimated Quantitation Limit (mg/L)</u>	<u>RCRA Regulatory Limit (mg/L)</u>	<u>EPA HW#</u>
Vinyl Chloride	<0.05	0.05	0.2	D043
1,1-Dichloroethylene	<0.05	0.05	0.7	D029
1,2-Dichloroethane	<0.05	0.05	0.5	D028
Chloroform	<0.05	0.05	6.0	D022
Carbon Tetrachloride	<0.1	0.1	0.5	D019
Benzene	<0.05	0.05	0.5	D018
Chlorobenzene	<0.1	0.1	100	D021
Tetrachloroethylene	<0.05	0.05	0.7	D039
2-Butanone (MEK)	<1.0	1.0	200	D035
Trichloroethylene	<0.05	0.05	0.5	D040
<u>Surrogate Recovery: Volatiles</u>		<u>% Recovery</u>	<u>Acceptable Recovery Range</u>	
Dichloroethane-d4		107	80-120%	
Toluene-d8		107	88-110%	
4-Bromofluorobenzene		97	88-115%	
Semi-Volatiles				
<u>Analyte</u>	<u>Results (mg/L)</u>	<u>Estimated Quantitation Limit (mg/L)</u>	<u>RCRA Regulatory Limit (mg/L)</u>	<u>EPA HW#</u>
O-Cresol	<1.0	1.0	200	D023
M & P-Cresol	<1.0	1.0	200	D024,D025
Total Cresols	<1.0	1.0	200	-----
1,4-Dichlorobenzene	<1.0	1.0	7.5	D027
2,4-Dinitrotoluene	<0.1	0.1	0.13	D030
Hexachlorobenzene	<0.1	0.1	0.13	D032
Hexachlorobutadiene	<0.1	0.1	0.5	D033
Hexachloroethane	<1.0	1.0	3.0	D034
Nitrobenzene	<1.0	1.0	2.0	D036
Pentachlorophenol	<10	10	100	D037
Pyridine	<5.0	5.0	5.0	D038
2,4,5-Trichlorophenol	<2.0	2.0	400	D041
2,4,6-Trichlorophenol	<2.0	2.0	2.0	D042
<u>Surrogate Recovery: Base Neutrals</u>		<u>% Recovery</u>	<u>Acceptable Recovery Range</u>	
Nitrobenzene-d5		76	35-114%	
2-Fluorobiphenyl		77	43-116%	
p-Terphenyl-d14		89	33-141%	
<u>Acids</u>				
Phenol-d5	63		10-94%	
2-Fluorophenol	23		21-100%	
2,4,6-Tribromophenol	104		10-123%	

IV. MOBILE DIESEL GENERATORS

A. BACKGROUND

Mobile diesel generators of three general types can be found at military bases. At Air Force facilities, the most-common type is called aerospace ground equipment (AGE). AGE is used to service aircraft that are on the ground. While not in use, they are generally housed in or adjacent a building that is next to an aircraft runway or tarmac. A second common mobile diesel type is the mobile auxiliary power generator. These units generally are of a different design than AGE, and they are used in a variety of different base applications. Typically, when not in use, they are parked at a central location near a maintenance facility. From there, they are dispatched to temporary usage sites. The third type of mobile diesel generator is those where the generators are permanently affixed to another piece of equipment and the total system is moved from site to site. An example of this type is the CO₂-blasting facility at McClellan AFB.

Of the different mobile diesel generator types, AGE has received most attention in recent years. High levels of NO_x emissions from AGE have been cited as the principal cause of noncompliance with existing standards in California and has resulted in threatened base shutdowns. In fact, the Strategic Environmental Research and Development Program (SERDP) office has spelled out the control of NO_x emissions from AGE as one of its most important goals.

The sorption approach was selected as the method to be used to control NO_x emissions in mobile diesel generator applications at Air Force sites. It was believed that an ideal NO_x filter would be one that could be installed directly on the mobile diesel unit. However, the results of earlier laboratory tests showed that the NO_x filters would, by necessity, be large. Also, significant changes in the design of the mobile diesel generator units would be necessary to incorporate the filters and elated equipment. For these reasons, it was decided to develop a separate mobile unit, a filter cart. The mobile filter cart would be designed to be attached to and to be pulled along with the mobile diesel generator.

A photograph and a schematic drawing of the filter cart are provided in Figures 12 and 13, respectively. Although the cart was designed specifically to control exhaust-gas emissions from facilities burning diesel fuels, it is believed capable of controlling emissions from facilities that burn other fuels, such as natural gas, gasoline, coal, solid wastes (incinerators), and jet-engine fuels. The mobile filter cart consisted of a frame structure on which is mounted separate units to remove moisture and particulates, to lower the temperature of the gas stream, and to capture nitrogen oxides and other undesirable pollutants. Particulate capture was achieved with a prefilter; moisture was removed with a demister; the gas temperature was reduced with an air-to-air heat exchanger, or alternately by an ambient-air inductor; nitrogen oxides were captured with one or more beds of a special activated carbon. The frame structure was mounted on a wheel structure that allowed the apparatus to be readily moved from site to site.

B. PRELIMINARY TEST WORK

Preliminary test work was carried out at Wright-Patterson AFB and then at Youngstown ARB in Ohio. Prior to the design and construction of the filter cart, a series of runs were performed at Wright-Patterson AFB on a large slipstream of AGE exhaust gas using a test apparatus designed to evaluate different sorbent bed combinations and thicknesses. It was from the results of these runs that a combination of 3 to 4 inches of vermiculite and 6 to 8 inches activated carbon was

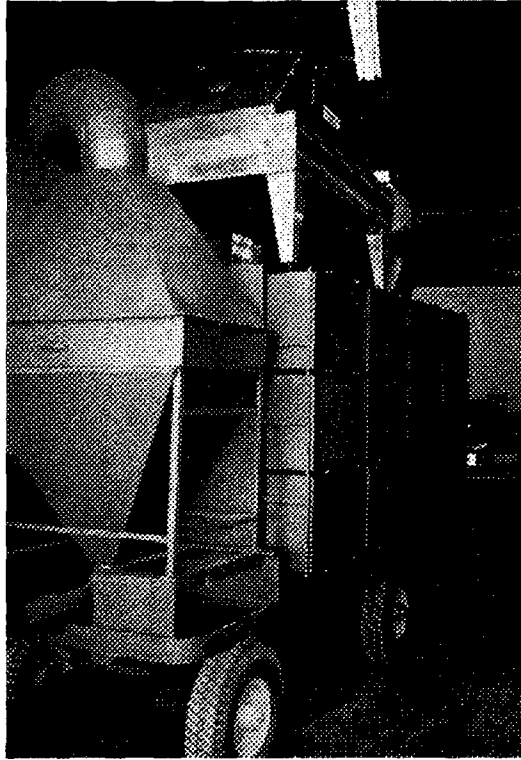

Figure 12. Photograph of Mobile Filter Cart

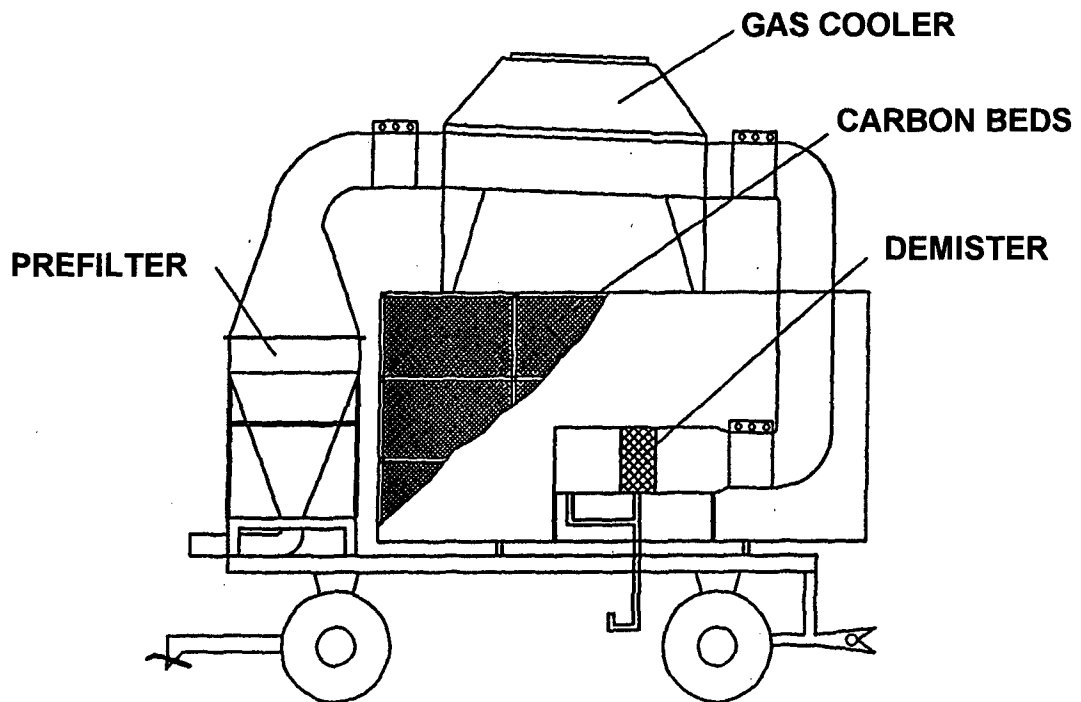

Figure 13. Mobile Filter Cart Design

selected for the filter cart. During these runs, the flow rate of exhaust gases from a typical 72-kW AGE was measured as a function of AGE power setting. These data are shown in Figure 14. The temperature of the exhaust gases leaving the AGE was generally about 300°F at no load and about 600°F at 80-percent load.

From the results of tests at Sorbtech's laboratories and at Wright-Patterson AFB, it was clear that the filter-bed concept would work if (1) the temperature of the exhaust gases were reduced sufficiently; (2) the amount of large liquid water droplets in the exhaust gas stream were minimized; (3) the majority of the particulate matter were removed from the gas stream before it entered the carbon bed(s); and (4) the exhaust-gas face velocity through the carbon bed(s) were limited to less than 2 feet per second. An air-to-air heat exchanger, supplied by XChanger, Inc., was selected to reduce the exhaust-gas temperatures. A demister, designed and supplied by Jaeger Products, Inc., was selected to remove water droplets. Vermiculite and other candidate materials were considered for the prefilter. Because the face velocity of the exhaust gases passing through the carbon beds varies inversely with the total surface area of the filters, low face velocities could be achieved by making the carbon filters large.

After the filter cart was designed, the front section containing the prefilter was fabricated and evaluated first. The prefilter was designed as a special drawer that could be easily and quickly removed and replaced when the filter media became fouled. A study was performed of the gas flows through the front section of the system, which resulted in the installation of flow diverters that channeled gases uniformly through the prefilter.

Coarse, expanded vermiculite beds of two thicknesses, two commercial filters, and kaolin wool were examined as potential prefilter materials in a series of test runs on a full AGE exhaust-gas stream at Youngstown ARB. Of the materials examined, only the vermiculite filters performed satisfactorily. An important observation made during these test runs was that the vermiculite filters were particularly effective in removing PM-10 and PM-2.5 particles from the exhaust gas streams. Another was that the performance of the vermiculite prefilters was not significantly affected by exhaust gas velocity. Good removals were seen even with high gas flow rates, and the particulates appeared to be collected for the most part within one inch of the front surface of the filter beds.

The ability of the filters to capture particulates from exhaust gases was evaluated by measuring the particulate levels of gases entering and leaving the beds during runs. A special unit was designed and built to collect samples. The units were designed on the assumption that filters having a specific pore size will allow particles smaller than that size to pass through and particles larger to be held back. Figure 15 shows the particulate-sampling device in assembled and disassembled forms.

The collector units were placed immediately before and immediately after the beds. Each unit captured particles in two nominal size ranges, greater than 2.7 μm and between 0.3 and 2.7 μm . Particles smaller than 0.3 μm were assumed to pass through the units. The flow rate of gas into the sampling systems was balanced with the flow rate of the gas in the exhaust gas duct so gas velocities in the units and in the duct were the same. Filters inside the units were weighed carefully before and after a test run. The differences in the weights of particulates in the incoming-gas unit and in the outgoing-gas unit were used to indicate the net particle removal rate of the beds.

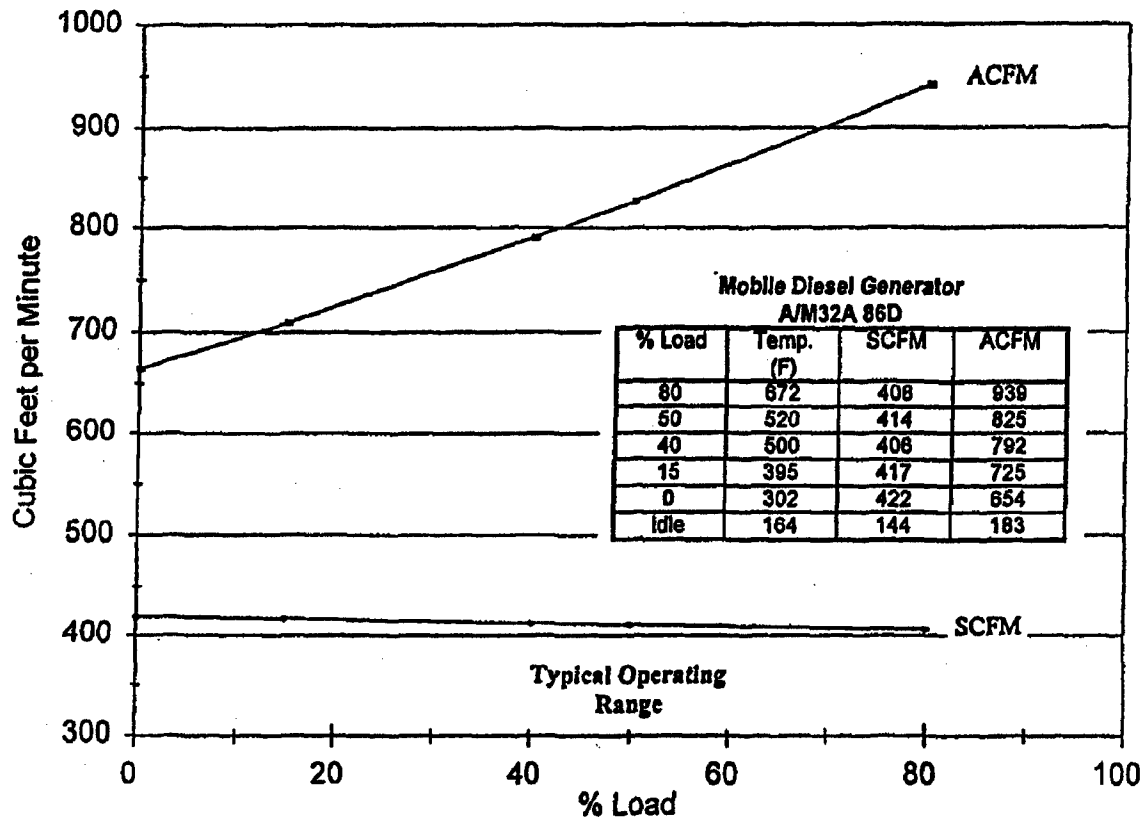

Figure 14. Exhaust Gas Flow Rate as a Function of Operating Load for a 72-kW AGE

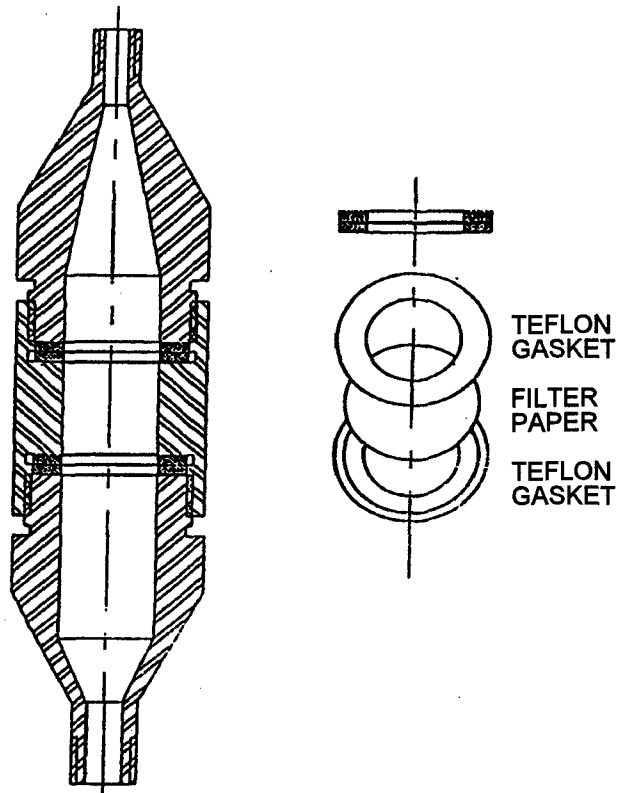

Figure 15. Particulate Sampling Device

C. INITIAL MOBILE FILTER TRIALS

Following the prefilter tests at Youngstown ARB, the front section of the cart was returned to the fabricator, Inland Manufacturing of Ravenna, Ohio, where it was attached to the remaining parts of the cart. The primary filter bed actually consisted of 24 separate beds, each 21.5 inches by 14 inches and 8 inches thick. One half of the beds lined the right side of the cart; the second half lined the left side. The beds were made relatively small to allow one person to easily remove them after they became saturated with NO_x. After the filter cart was completed, the special carbon was prepared and the individual filter beds were filled with the carbon. The filter cart was then transported to Youngstown ARB for a shakedown and evaluation test.

The Youngstown ARB test was performed on the total exhaust gas stream from a 110-kW AGE unit operating at its normal load for 3.5 hours. The test was performed outside on a cold day. (The air temperature was typically 25°F, with the wind chill factor well below 0°F.)

During the test, temperature, pressure, flow rate, and chemical analysis data were collected, along with samples of particulates and liquid condensate from the heat exchanger and demister. Also during the runs, it was observed that several beds settled more than expected. This resulted in open spaces at the top of the beds through which some exhaust gases passed untreated. Figure 16 shows the mobile filter cart during the test run.

The following observations were made on the basis of the shakedown and evaluation test results:

1. The temperature and gas flow measurements indicated that the exhaust gases were distributed uniformly over the primary filter surfaces. During the test, the temperatures of the beds increased slightly, typically 20 to 40 F degrees, confirming laboratory results that indicated the sorption reactions are exothermic.
2. Even though openings occurred at the tops of the carbon beds, overall average NO_x removals were good. The average NO_x removal rate was 80 percent (87.9 percent NO₂ and 77.6 percent NO). Removals were fairly constant throughout the test run. NO and NO₂ levels were measured with an Enerac 3000E gas analyzer.
3. The prefilter did an excellent job in removing particulates. About 92.5 weight percent of the coarse particulates (larger than 2.7 microns in size) and nearly 100 percent of the fine particulates (0.3 to 2.7 microns in size) were removed by the prefilter during the 3.5-hour-test period. Particulate measurements were made by removing gas samples concurrently and isokinetically before and after the prefilter, capturing particulate fractions on series of filters, and drying and weighing the collected particulates.
4. The demister performed well and the air-to-air heat exchanger performed better than expected. The heat exchanger dropped the exhaust-gas temperature from about 230°F to 21°F during the run. When the exiting gas temperature was in the range of 21°F to 29°F, condensing water froze in the water exit lines. Approximately half way through the run, the exit gas temperatures rose to about 32°F. The ice in the lines melted, and water was released.

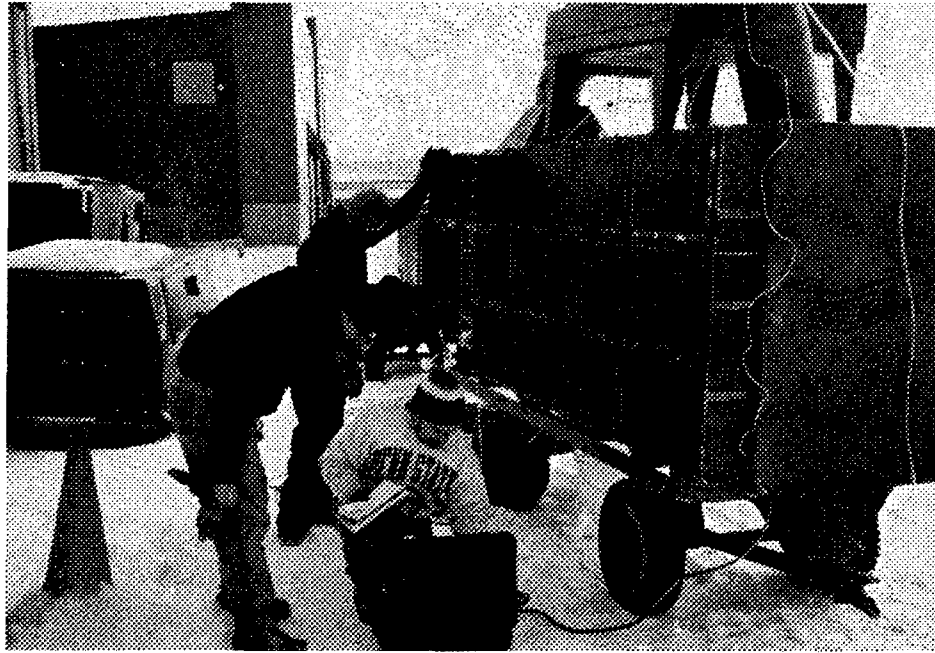
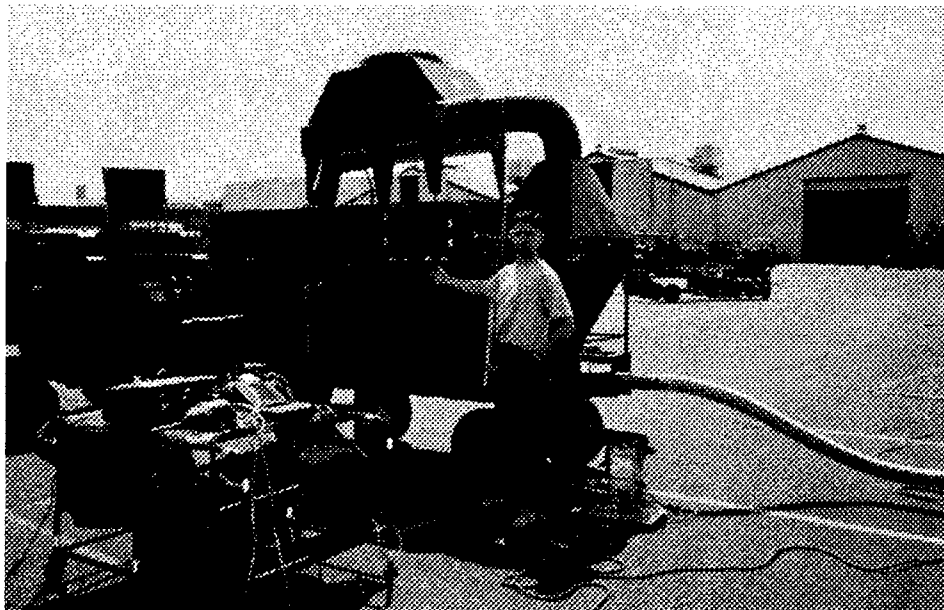

Figure 16. Collecting Data on Filter Cart Performance at Youngstown ARB



**Figure 17. Filter Cart Testing on an AGE Unit
near the Flight Line at McClellan AFB**

5. An average of approximately one gallon of aqueous condensate per hour was produced and collected during the test run. The condensate was brownish in color, possessed a faint volatile-organic odor, and had a pH of 4.0. An initial laboratory analysis showed it contained 40 ppm nitrates and no detectable nitrites. A sample was sent to an outside laboratory for analysis using EPA-600, Method 602. The analysis results are provided in Table 6.

D. FIVE APPLICATIONS EXAMINED AT McCLELLAN AFB

Following the Youngstown ARB trials, new, improved seals were designed and were installed in the tops of the carbon beds. Prior to the shipment of the filter cart, the exhaust gases from a mobile diesel auxiliary power unit at McClellan were characterized. Data collected during characterization are given in Appendix A-3. The filter cart was then shipped to McClellan AFB in California for testing.

Four applications were then examined at McClellan AFB. They were:

- 1) An operating AGE located near the flight line.
- 2) A poorly performing AGE being serviced at the repair shop.
- 3) A mobile diesel auxiliary power unit.
- 4) A CO₂-blaster compressor.

1. AGE near the Flight Line

The 72-kW, 60-Hz AGE near the flight line was similar to the unit employed at Youngstown ARB. A flexible metal tube, shown in Figure 17, was used to connect the tail pipe of the AGE to the inlet of the mobile filter cart. The total test run time was over 4 hours. Unlike in the Youngstown trials, SO₂ was detected in the exhaust gases leaving the AGE. The results of the mobile filter tests on the AGE exhaust gases are summarized below:

Average NO Removal	96.6%
Average NO ₂ Removal	99.1%
Average SO ₂ Removal	95.6%

After these tests, no changes were made to the cart, and the cart was transported to the AGE Repair Building at McClellan AFB.

2. AGE at the Repair Shop

The 60-kW, 60-Hz AGE selected for study at the repair shop was considered a "smoker." A smoker is a unit that emits large amounts of smoke (unburned carbon) during its normal operations. Oftentimes when an AGE is optimized for low NO_x emissions, the result is an overabundance of unburned carbon emissions due to retarding the ignition timing.

The demonstration and evaluation run at the repair shop was carried out during the second day of testing. A 72-kW, 400-Hz AGE in the repair shop was later used for long-term testing. After about an hour of initial testing, it became clear from pressure-drop measurements across the prefilter that the prefilter was becoming heavily saturated with particulates. It was at

that time that a new prefilter was installed and the test run was continued. The results of the mobile filter tests on the repair-shop AGE exhaust gases are given below:

Average NO Removal	92.6%
Average NO ₂ Removal	100.0%

3. Mobile Diesel Auxiliary Power Unit

Mobile diesel auxiliary power units come in a variety of sizes. They are similar in many respects to AGE, but are not generally used to service aircraft. They produce and supply power to fill many needs at military bases. The mobile filter cart was moved to the auxiliary-power-unit area at McClellan AFB and was connected to a 100-kW, 60-Hz auxiliary power generator. The results of a 3-hour run were as follows:

Average NO Removal	95.0%
Average NO ₂ Removal	98.8%

4. CO₂-Blaster Compressor

A CO₂-blaster is a new technology being employed at McClellan AFB to remove old paint from aircraft structures. In this technology, CO₂ is solidified into hard pellets, and the pellets, in turn, are propelled at paint-covered metal components, in a manner not unlike sandblasting. The CO₂ eventually evaporates leaving behind only a paint-metal residue. A diesel-fueled compressor is employed in preparing the CO₂ pellets, and the compressor produces undesirable levels of NO_x. Use of the filter cart to control NO_x emissions from the compressor was studied for two normal operating conditions, idle and normal load. The results were as follows:

Idle

Average NO Removal	96.8%
Average NO ₂ Removal	100.0%

Normal Load

Average NO Removal	92.3%
Average NO ₂ Removal	96.5%

E. APPLYING REGENERATION AND NO_x DESTRUCTION TO THE FILTER CART

1. Development of a Regeneration and NO_x Destruction Process

In Sorbtech's activated carbon regeneration and NO_x destruction process design, the NO_x-capture capabilities of the activated carbon are restored by simple heating, and concentrated NO_x released during the regeneration is destroyed. At least two schemes can be used to destroy the concentrated NO_x streams. In laboratory studies described in Section III, one scheme involving magnesium oxide, methane, and high temperatures and a second involving a commercial palladium-based catalyst, hexane, and low temperatures were demonstrated successfully in the laboratory.

A process-flow diagram for regeneration and NO_x-destruction is shown in Figure 18. Key components of the process are the regenerator, a hot-gas recycling system, a gas compressor and pressurized storage vessel, gas regulators, mixer and preheater, the NO_x-destructor, and an incinerator. The regenerator may be the filter bed itself, if regeneration-in-place is being carried out. With the exception of the NO_x-destructor, all components are commercially available, off-the-shelf items.

The function of the hot-gas recycling system is to supply heated gas to the saturated carbon bed(s) to achieve regeneration of the carbon and the capture of the released NO_x. The compressor functions to reduce the volume of the evolved gases and to supply the gases in compressed form to a pressurized storage vessel. The storage vessel allows the mixing of the evolved gases to level out their composition and the storage and supply of gas to the NO_x destructor under positive pressure and at a controlled rate. The regulators provide a uniform, controllable flow of gases to the gas mixer and ultimately to the gas preheater and catalytic NO_x destructor. An optional incinerator is used to combust any residual reducing gases that may be present in the final exhaust gas.

2. Experimental NO_x-Destruction Test Results

In the initial mobile filter design, the activated carbon beds, after they become saturated with NO_x, are individually removed and then taken to a regenerator NO_x-destructor site, where they are regenerated. The carbon beds are then returned to the cart and reinserted into its structure. In the latest mobile filter design, the removal and reinsertion steps are eliminated. Instead, the cart is moved to the NO_x destruction site, where the beds are regenerated in place. To test the more-recent concept, a simulated commercial-scale facility was designed and installed in the laboratory. This facility was then tested on 0.1-ton and larger quantities of activated carbon that had been saturated with NO_x earlier at McClellan AFB.

F. DISCUSSION OF RESULTS

1. NO_x Removal Performance with the Filter Cart

The activated carbon beds on the filter cart were exposed to NO_x-containing diesel exhaust gases for over 70 hours before they were replaced. A history of their performance is shown in Figure 19. Both NO and NO₂ were effectively removed for about 40 hours, after which removal efficiency slowly decreased to about 50 percent after 50 hours and 30 percent after 60 hours. The saturated activated-carbon-bed materials were then returned to Sorbtech's laboratories for regeneration and NO_x destruction work.

A summary of NO_x-removal data for the four mobile-diesel-engine applications examined at McClellan AFB is given in Table 8. The average NO removal during all runs was 94.7 percent. The average NO₂ removal was 98.9 percent.

A brown-colored aqueous condensate was collected continuously from the demister during each test run. The liquid possessed a faint volatile-organic odor and had a pH of 4.0. The amount of condensate collected varied widely for the different applications. For the AGE, the typical collection rate was 3 liters per hour; for the CO₂-blaster and auxiliary power units, the rates were in the range of 12 to 15 liters per hour. A sample of the condensate was sent to an outside laboratory, B.E.C. Laboratories, Inc., of Twinsburg, Ohio, for analysis using EPA-600, Method 602. The results of the analysis are given in Table 9. Independent analysis of samples

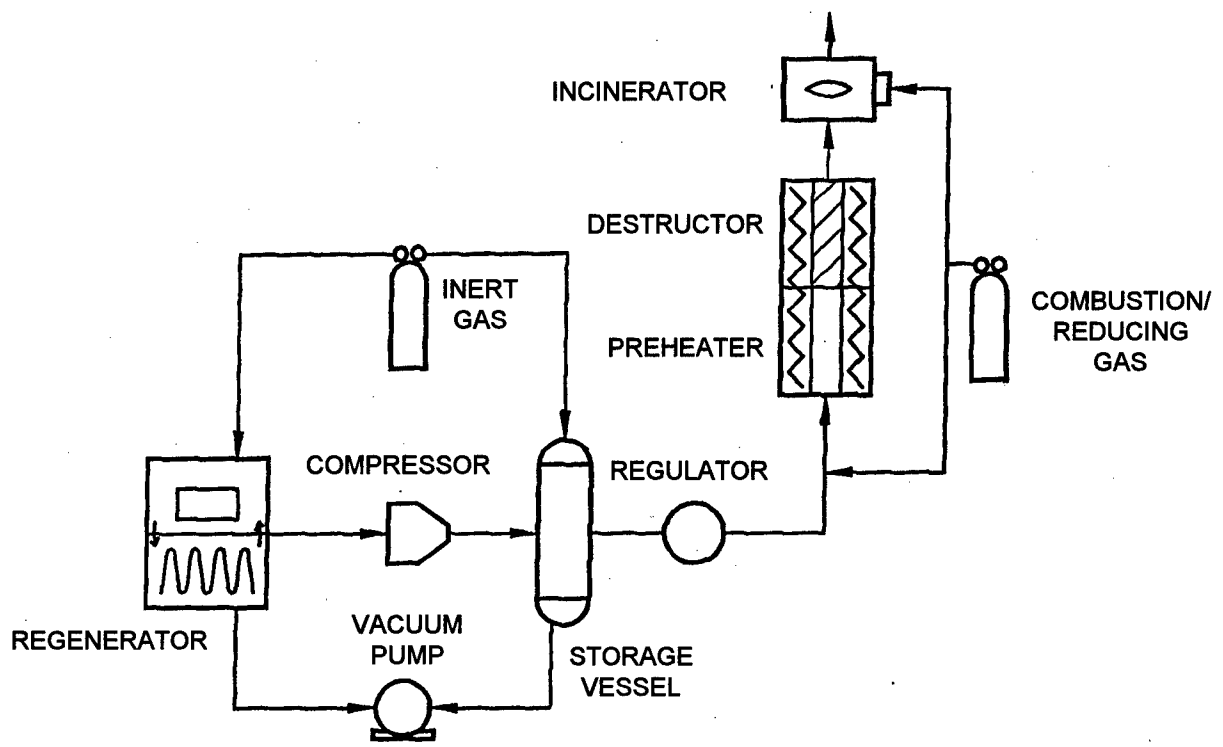

Figure 18. Sorbent Regeneration and NOx-Destruction Process

of the condensate, collected by Alan Canfield of Applied Research Associates, Inc. and analyzed at the Environmental Laboratory at McClellan AFB, showed that condensate production increases with increasing local relative humidity.

TABLE 8. AVERAGE NO_x REMOVALS DURING FOUR-HOUR RUNS WITH THE MOBILE FILTER CART

<u>APPLICATION</u>	<u>Average % NO Removal</u>	<u>Average % NO₂ Removal</u>
72-kW, 60-Hz AGE*	96.6	99.1
60-kW, 60-Hz AGE	92.6	100.0
Mobile Auxiliary Power Unit	95.0	98.8
CO ₂ -Blaster Compressor		
Idle	96.8	100.0
Normal Load	92.3	96.5
Average	94.7	98.9

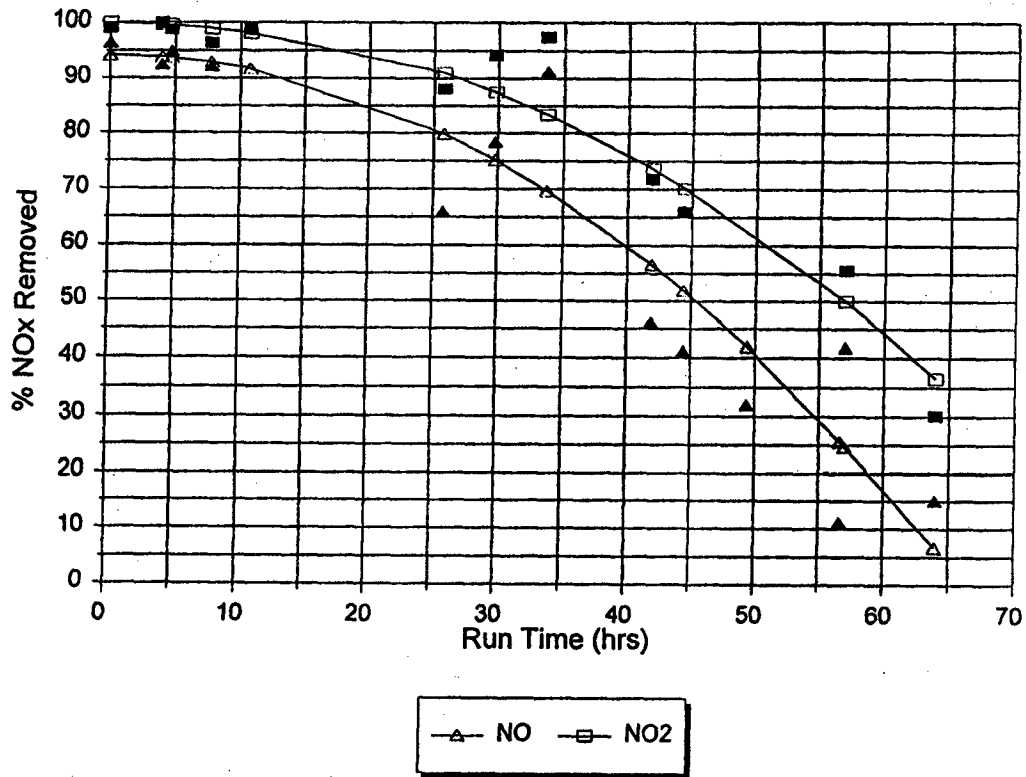

Figure 19. Average NOx Removals with the Mobile Filter Cart

TABLE 9. ANALYSIS OF CONDENSATE COLLECTED DURING A SHAKEDOWN RUN

<u>Component</u>	<u>Amount</u>
Total Organic Carbon	400.0 mg/L
Nitrates, as N	6.9 mg/L
Benzene	3.5 µg/L
Toluene	4.5 µg/L
Ethylbenzene	1.0 µg/L
m- and p-Xylene	1.2 µg/L
o-Xylene	2.5 µg/L

2. Experimental NO_x-Destruction Test Results

The results of laboratory experiments with methane as the reducing gas and MgO as the catalyst showed that the reducing gas-to-NO_x ratio and the reaction temperature were two important variables in the destruction of NO_x. The presence of oxygen in the gas stream in amounts up to 3 percent, on the other hand, demonstrated only minimal effects. Typical laboratory results showing the temperature and oxygen concentration effects are given in Table 10. Test results indicated that good NO_x destruction occurs at temperatures above 750°F; essentially no destruction occurs at temperatures below 700°F.

In the initial mobile filter design, the individual activated carbon beds, after they become saturated with NO_x, are individually removed and then taken to a regenerator-NO_x destructor site, where they are regenerated. The carbon beds are then returned to the cart and reinserted into its structure.

In a new mobile filter design, the removal and reinsertion steps would be eliminated. Instead, the cart would be moved to the NO_x destruction site, where the beds would be regenerated in place. To test the more-recent concept, a simulated commercial-scale facility was designed and installed in the laboratory. This facility was then tested on 0.1-ton and larger quantities of activated carbon that had been saturated with NO_x earlier at McClellan AFB. The results of three regeneration NO_x-destruction runs are summarized in Table 11. The regeneration facility is shown in Figure 20, the destructor is shown in Figure 21. Essentially complete sorbent regeneration and 99.9-percent NO_x destruction was achieved with the new facility.

TABLE 10. EFFECTS OF TEMPERATURE AND OXYGEN CONCENTRATION ON NO_x-DESTRUCTION PERFORMANCE

NO_x Destruction vs. Temperature

CH₄:NO = 0.36

Space Velocity = 1200 hr⁻¹

Temp. (C)	NO _x Destroyed
100	0.0%
350	0.0%
600	0.0%
700	0.0%
750	99.2%
800	99.1%
850	99.9%

NO_x Destruction vs. O₂ Level in Gas

CH₄:NO = 0.30

Space Velocity = 1200 hr⁻¹

Temperature = 800°C

% Oxygen	NO _x Destroyed
1.0	98.6%
2.0	98.8%
4.0	97.9%

CH₄:NO = 0.15

Space Velocity = 1200 hr⁻¹

Temperature 800°C

% Oxygen	NO _x Destroyed
1.1	86.2%
2.2	86.0%
3.1	84.9%

TABLE 11. THE RESULTS OF LARGE-SCALE REGENERATION-IN-PLACE WITH NO_x-DESTRUCTION EXPERIMENTS

Temp. (C)	CH ₄ :NO Ratio	Carbon Condition After Regeneration	% NO _x Destroyed	% CH ₄ Utilized
850	0.31:1	Good, well regenerated	99.0	92.4
800	0.27:1	Good, well regenerated	99.9	96.8
800	0.21:1	Good, well regenerated	89.0	99.0

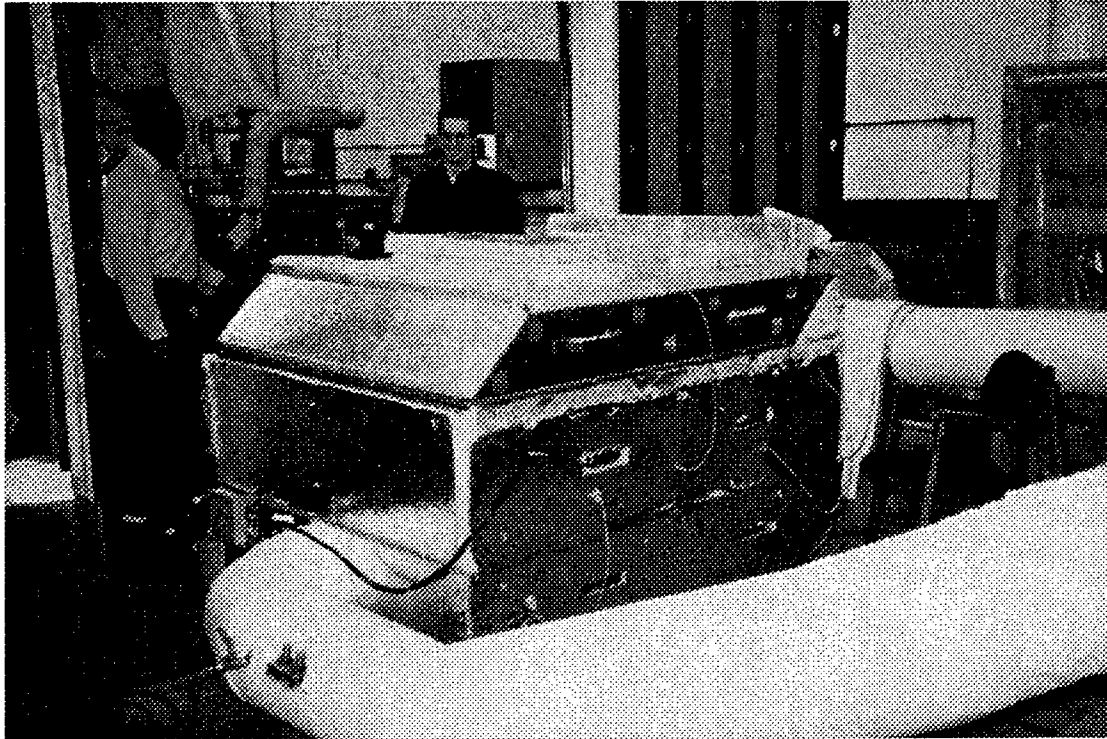

Figure 20. Laboratory Testing of a Regeneration-in-Place System

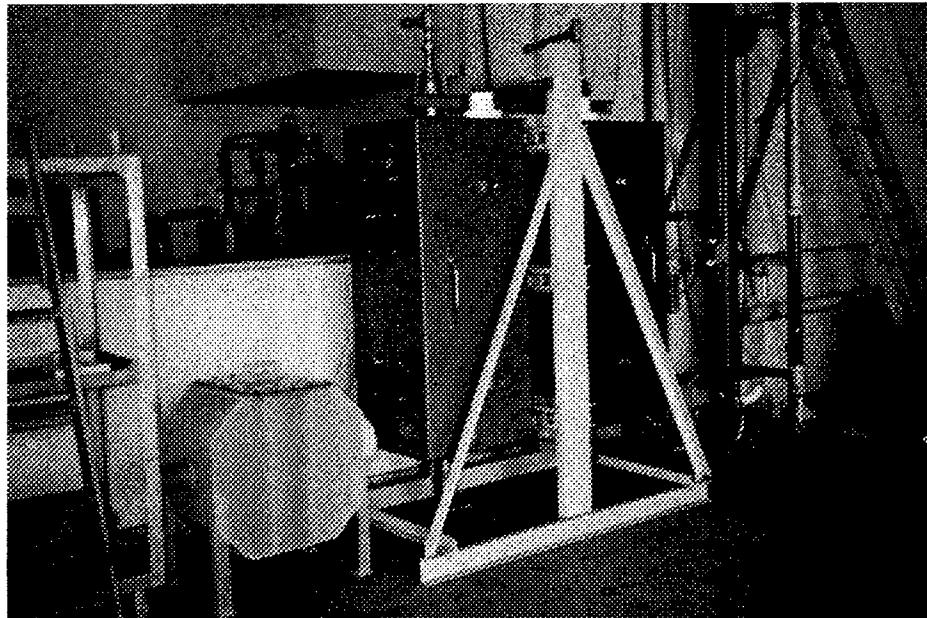

Figure 21. NOx Destructor

G. FILTER CART/NOx-DESTRUCTION COSTS

What costs can be expected in capturing NOx and small particulates with the filter cart and destroying the NOx at a NOx-destruction station? Based on designs developed in the project and on actual costs incurred in constructing prototypes, a detailed analysis of costs, both capital and operating costs, was made. These costs were then related to expected NOx removals.

The analysis is summarized in Table 12. Because the filter cart is particularly applicable to mass production methods, the capital cost of a filter cart is sensitive to the number of carts manufactured. The analysis assumed the manufacture of 100 filter cart units. A simple NOx-destruction station, on the other hand, is capable of serving many filter carts. Far fewer stations, therefore, would be required. As a consequence, cost estimates were developed on the basis of multiple filter carts and of single-unit NOx-destruction station manufacture.

The estimated 1997 capital cost for a mobile filter cart is \$14,000 to \$17,000. The higher cost incorporates a regeneration-in-place capability. The estimated cost for a NOx-destruction station is \$47,000. The annual operating costs for both units (capturing and destroying 2.73 TPY of NOx) are estimated to total about \$6,150 per year. These numbers translate to a NOx-control cost of \$2,983 per ton of NOx controlled.

Capital Cost/Ton NOx Captured

Capital Cost Plus Financing

Capital Cost	\$ 47,000
Cost of Capital (20 yr @ 6%)	<u>39,440</u>
Cost over 20 yr	\$ 86,440

The NOx Destruction Station can handle 10 carts per 40-hour week, with a total destruction capability of well over 100 TPY NOx. If one assumes the station services but 10 carts, and the capital cost is distributed over these 10 carts, then:

Capital Cost Component = \$158/T NOx Removed

OPERATING COSTS (PER FILTER CART PER YEAR)

Basis: Regeneration is required once every 2 weeks, releasing 105 lb NOx (or 2.73 TPY NOx per Filter Cart)

Cost Breakdown:

Filter Cart

Cart Operation & Maintenance (2% of Capital Cost)	\$	300
Replacement Materials		
Prefilter Media (12 changes/year)		1,200
NOx Sorbent (10%/year)		<u>150</u>
Total	\$	1,650

NOx Destruction Station

Labor (104 hr @ \$25)	\$	2,600
Maintenance		130
Gases (N ₂ , methane 26 cycles)		1,300
Electricity - 3,700 KWhr @ \$.10		370
Misc. Chemicals & Supplies		<u>100</u>
Total	\$	4,500

COST PER TON OF NOx REMOVED

	<u>Cost/T of NOx Removed</u>
Capital Cost - Mobile Filter Cart	\$ 573
Capital Cost - NOx Destruction Station	158
Operating Cost - Mobile Filter Cart	604
Operating Cost - NOx Destruction Station	<u>1,648</u>
Total Cost per Ton of NOx Removed and Destroyed*	\$ 2,983

*Note that this cost also includes the almost complete removal of particulates, as well as NOx.

**TABLE 12. ESTIMATED CAPITAL AND OPERATING COSTS --
FILTER CART/NO_x DESTRUCTION**

CAPITAL COSTS - MOBILE FILTER CART

Basis: 100 units

Cost Breakdown:

Activated Carbon	\$	150,000	
Prefilter Assemblies		200,000	
Heat Exchangers		450,000	
Demisters		20,000	
Cart Bases		60,000	
Frames & Piping		120,000	
Paint & Misc. Materials		100,000	
Assembly & Engineering		100,000	
Regeneration-in-Place Capability (Optional)		300,000	
Profit		<u>200,000</u>	
Total	\$	1,700,000	or \$14,000 to \$17,000/Mobile Filter Unit

Capital Cost/Ton NO_x Captured

Capital Cost Plus Financing

Capital Cost	\$	17,000
Cost of Capital (20 yr @ 6%)		<u>14,270</u>
Cost over 20 yr	\$	31,270

With 2.73 TPY NO_x Captured:
Capital Cost Component = \$570/T NO_x Removed

CAPITAL COSTS - NO_x DESTRUCTION STATION

Basis: One station, with a three-hour cycle time; 99.9% NO_x Destruction

Cost Breakdown:

Fan	\$	1,000
Compressor		20,000
Tanks		2,000
Destructor/Including Catalyst		7,000
Gas Analyzer/Safety Items		6,000
Instrumentation		3,000
Assembly & Engineering		2,000
Profit		<u>6,000</u>
Total	\$	47,000

V. STATIONARY DIESEL GENERATORS

A. BACKGROUND

Large stationary diesel engines can be found at many military installations. They are commonly employed to provide auxiliary electrical power or steam. At McClellan AFB, They provide power to assure that controlled conditions are maintained in certain buildings. Three stationary diesel engines at McClellan AFB are shown in Figure 22.

Air pollution is a major concern in the operation of large stationary diesel engines. Owing to their general nature, these engines produce significant amounts of small particulates (smoke) and NOx. Owing to their size, these amounts tend to be large. The exhaust gases from Stationary Diesel Engine 1 at McClellan AFB were characterized. The results are listed in Appendix A-4. Typically, NOx levels were high, up to 1000 ppm. Under non-idle conditions, the engine produced and discharged 2.6 to 6.3 pounds of NOx per hour. The levels of CO at idle likewise were high (over 400 ppm).

Three options were investigated for controlling NOx at the Stationary Diesel Engine facility (Building 262):

- (1) Employing an approach similar to that used with mobile diesel units (use of an activated carbon filter);
- (2) Recycling the exhaust gases back through the diesel engine;
- (3) Converting the NO in the exhaust gases into NO₂ and washing (scrubbing) the NO₂ from the stream.

Of the three above options, the third option (converting the NO to NO₂ and scrubbing) appeared most appropriate owing to the large quantities of NOx requiring treatment. Although the other options were examined in the project, emphasis was placed on the third option.

B. APPROACHES

1. NO-to-NO₂ Conversion and Scrubbing

Nitric oxide (NO) is generally the predominant nitrogen oxide species in most exhaust gases, making up 80 to nearly 100 percent of the total NOx. Most NO, after its release into the atmosphere, converts into nitrogen dioxide (NO₂), but the conversion is relatively slow.

In the past, efforts to wash NO from exhaust gases with water or with aqueous solutions has been futile. NO is essentially not soluble in water. NO₂, on the other hand, is slightly soluble and can be removed by scrubbing. Although water scrubbing alone will remove large amounts of NO₂, additives are sometimes needed to achieve near total NO₂ removal.

Two factors are important in the control of NOx by NO-to-NO₂ conversion and scrubbing. They are (1) the approach employed in converting NO to NO₂ and (2) the approach used in washing the NO₂ from the exhaust gases. The conversion of NO to NO₂ in the waste gas stream obviously requires the presence of oxygen or an oxygen-containing species to react

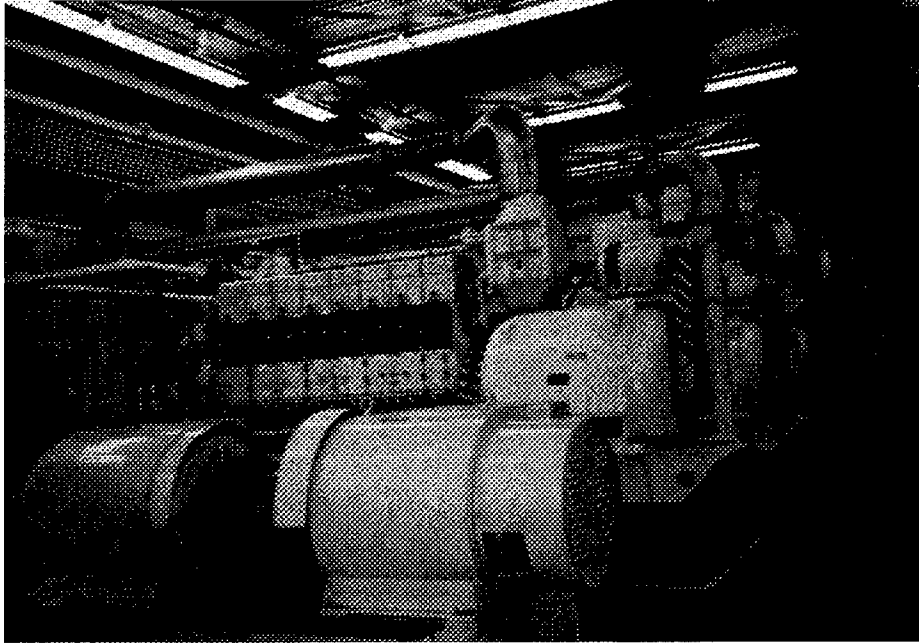

Figure 22. Stationary Diesel Engines at McClellan AFB

with the NO. Methods by which the reaction may be increased include employing an oxidation catalyst or introducing an oxidant, such as ozone. Both of these methods were examined in the project.

Washing the NO₂ from an exhaust gas may be accomplished in several ways. Two common ways are in a spray tower or in a bubbling bed. Additives made to wash waters in the past for NO_x scrubbing include strong bases, such as sodium hydroxide (NaOH) or calcium hydroxide (CaOH), or specialty materials, such as sodium sulfide (Na₂S), sodium hydrogen sulfide (NaSH), sodium carbonate (Na₂CO₃), or activated carbon (C). These methods and additives were also examined in the project.

Early in the project it was discovered that certain activated carbons, when they become saturated with NO_x, begin converting NO into NO₂ when they are exposed to NO in an exhaust gas. The activated carbon in this case appears to act as a catalyst. If conversions of 90 percent or higher could be achieved with this simple, inexpensive material, then the attractiveness of the NO-to-NO₂ conversion and scrubbing approach would be greatly enhanced.

2. Activated Carbon Sorption of NO_x

To examine if the activated carbon sorption approach employed to treat AGE exhaust gases would work with stationary diesel engines, the mobile filter cart was moved to the stationary diesel-engine site at McClellan AFB and was connected to the exhaust-gas stack (See Figure 23). A special valve was designed, fabricated and installed at the top of the stack to permit by-passing of a portion of the exhaust gases, generally about 50 percent.

3. Recycling of Exhaust Gases

The effectiveness of recycling the exhaust gas, along with some dilution air, back to the stationary diesel engine to destroy NO_x was examined in two series of experiments. One series was performed on the stationary diesel engine at McClellan AFB; the second was carried out on a stationary diesel truck at Sorbtech's facilities. Recycling a large portion of the exhaust gases back into the air intake of a stationary diesel engine at McClellan AFB is shown in Figure 24.

C. DISCUSSION OF RESULTS

1. NO-to-NO₂ Conversion and Scrubbing

NO-to-NO₂ Conversion with Catalysts. Several activated carbons were examined for their abilities to convert NO into NO₂ after saturation. The Calgon carbon employed in the filter cart was observed to be particularly effective. A long-term (50-hour) run was performed with this material to examine its effectiveness with time. The results of this run, which was carried out at room temperature, are shown plotted in Figure 25. A 14.3-gram sample of fresh activated carbon was employed in the run. It was exposed to the same simulated exhaust gas employed in most test work in the project (450 ppm NO, 50 ppm NO₂, balance air with 10 percent oxygen). The gas in this case was dry. The gas flow rate and face velocity were 4 liters per minute and 2 feet per second, respectively.

As can be seen in Figure 25, during the initial 3 hours of the run, essentially all NO₂ and about 75 percent of the NO in the exhaust gas was sorbed onto the carbon. After that time, however, the amount of NO₂ leaving the bed continued to increase until it reached a level of about 450 ppm, while the amount of NO leaving the bed remained fairly constant.

Two variables, temperature and moisture content of the exhaust gas, were observed to affect NO-to-NO₂ conversions significantly. Increasing the exposure temperature and increasing the moisture content of the gas generally were detrimental to performance. Another variable, activated carbon type, affected performance. Carbons that were good sorbers of NO_x generally demonstrated good NO-to-NO₂ conversions when saturated. The importance of moisture can be seen in the bar graphs in Figure 26. Researchers at Pennsylvania State University developed several grades of activated carbon that they claim are minimally affected by moisture. The ability of these materials to work NO_x, however, was found to be less than that of the Calgon material and their NO-to-NO₂ conversion ability was no better.

Oxidation catalysts are employed in automobiles to convert CO into CO₂ in the presence of oxygen. To determine if these same catalysts might encourage the conversion of NO



Figure 23. Exhaust-Gas Line Leading to the Mobile Filter Cart

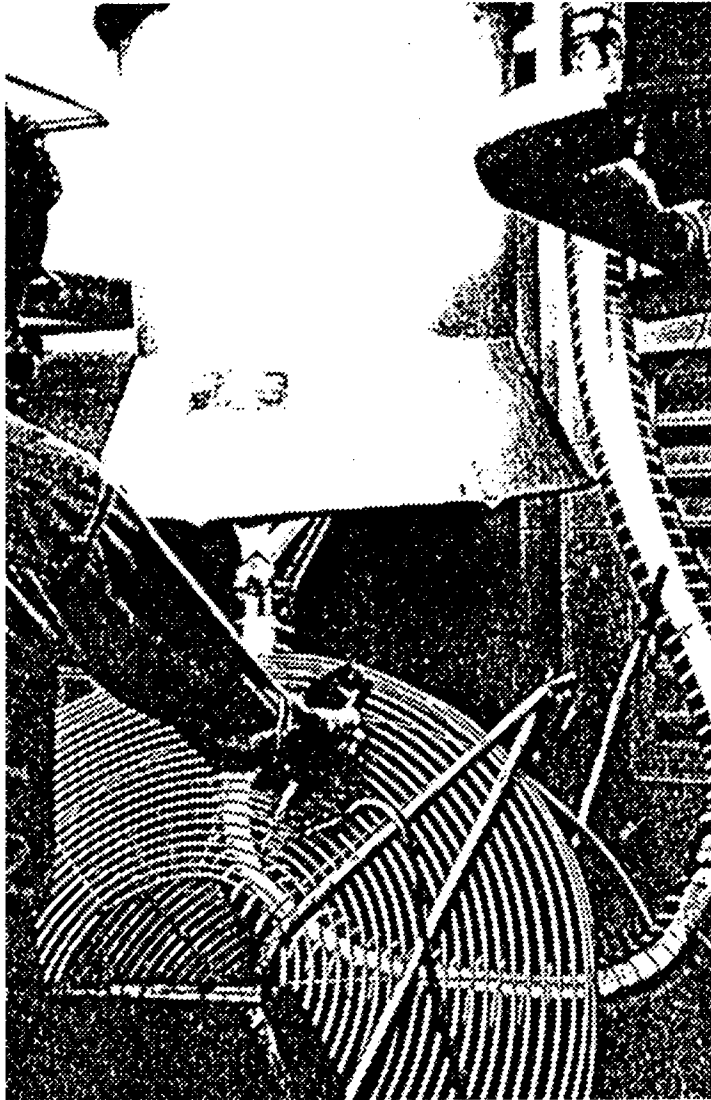

Figure 24. Recycling Diesel-Engine Exhaust Gases

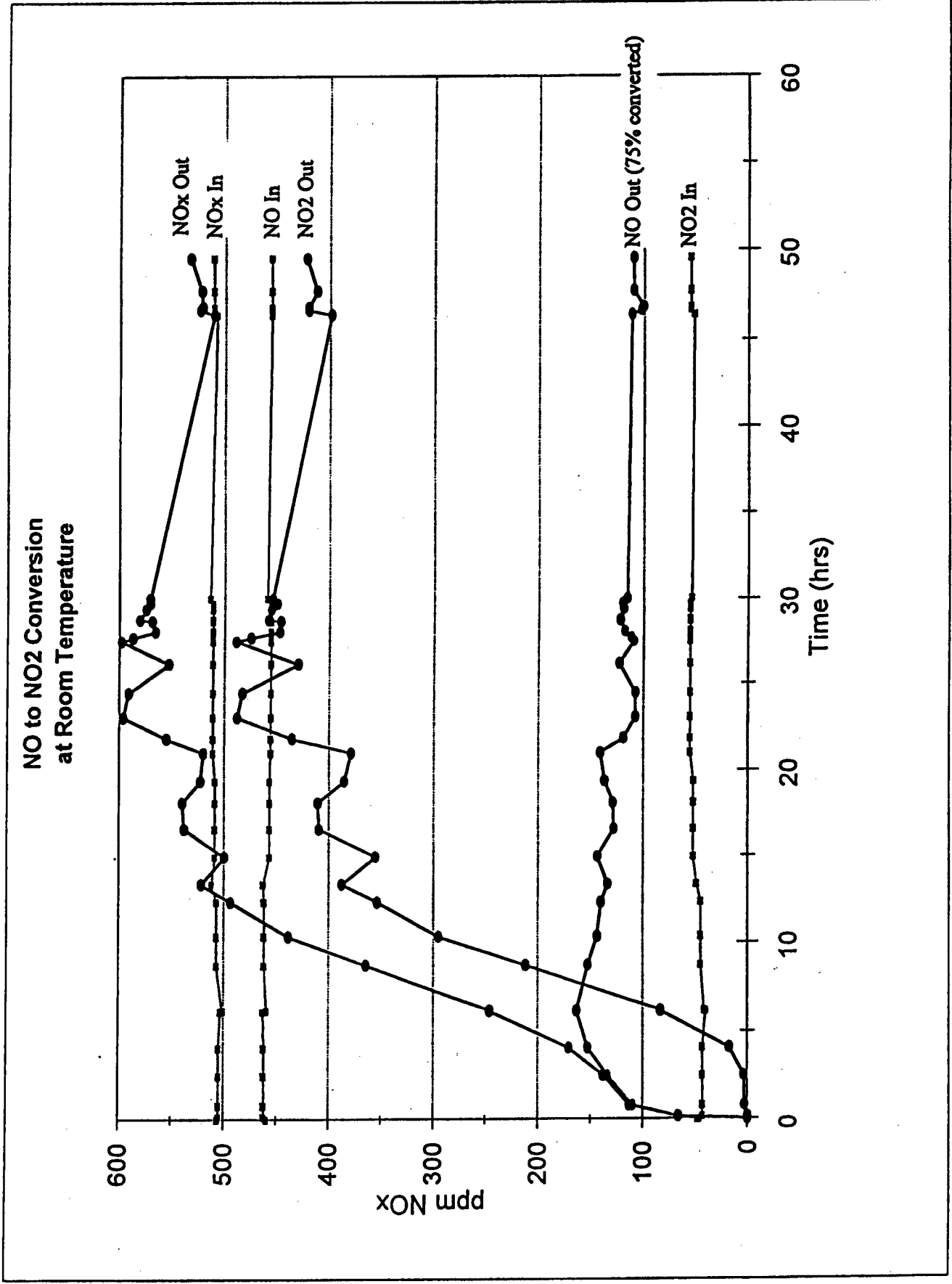

Figure 25. Conversion of NO to NO₂ with a Stationary Carbon Bed

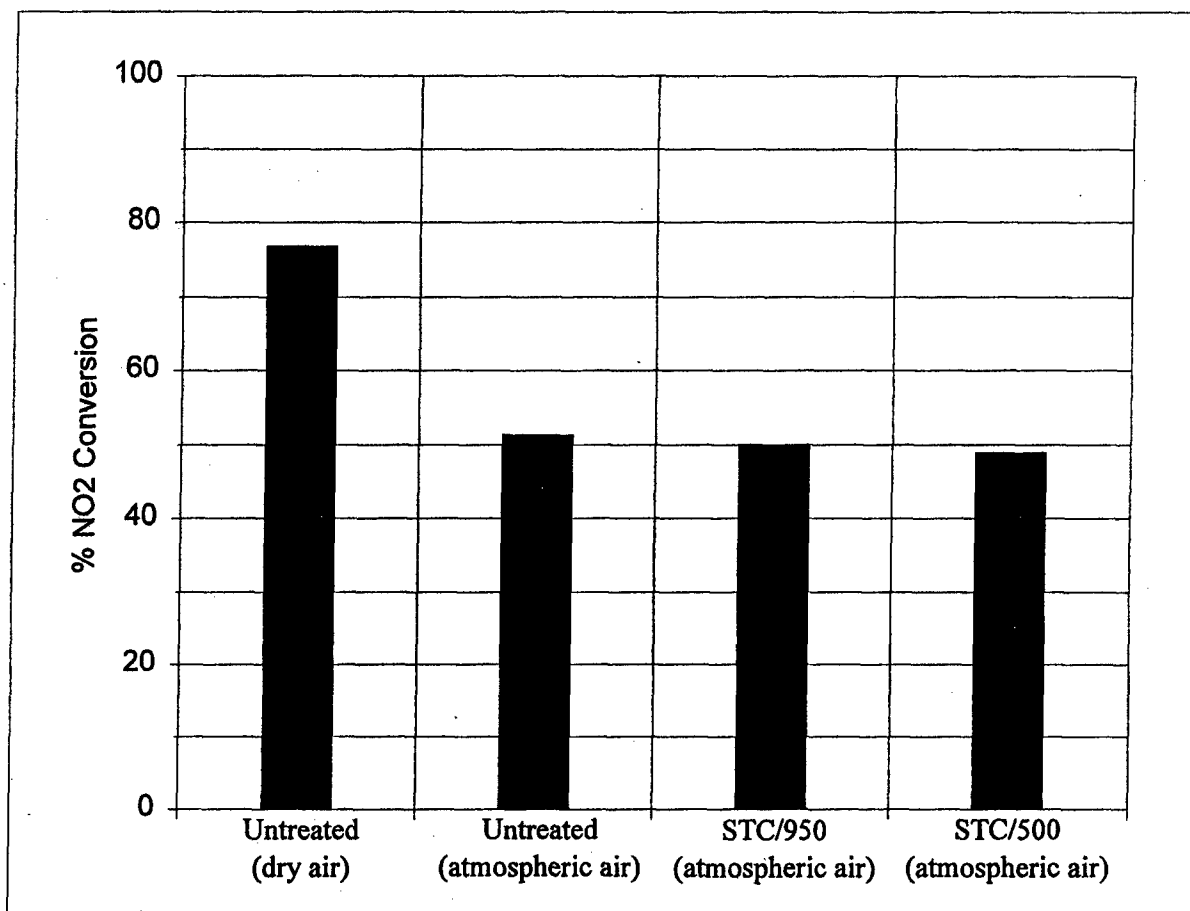

Figure 26. The Performance of Penn State's Materials (STC/950 and STC/500) in Comparison with Untreated Carbons

into NO₂, a catalyst consisting of dilute concentrations of platinum and rhodium on alumina spheres was secured and prepared by Sorbtech. The performance of this catalyst in converting NO to NO₂ in the presence of oxygen was then investigated as a function of temperature and as a function of residence time in a fixed bed of the catalyst at 700°F. Table 13 provides data that shows how temperature affected NO-to-NO₂ conversion efficiency with a 0.6-second residence time. How residence time affected performance is shown in Figure 27.

The oxidation catalyst was effective over the temperature range 650° to 750°F. At 700°F and with a simulated exhaust gas having the following composition,

NO -		450 ppm
NO ₂	-	75 ppm
O ₂	-	15 percent
CO ₂	-	5 percent, and
N ₂	-	balance,

NO-to-NO₂ conversions of between 80 and 90 percent were observed with a 1.0-second residence time.

**TABLE 13. NO-TO-NO₂ CONVERSION EFFICIENCY
WITH AN OXIDATION CATALYST
AT VARIOUS TEMPERATURES**

Temperature (F)	NO-to-NO ₂ Conversion (%)
500	28.9
550	46.3
620	51.1
650	58.1
700	72.7
750	61.6
820	46.7

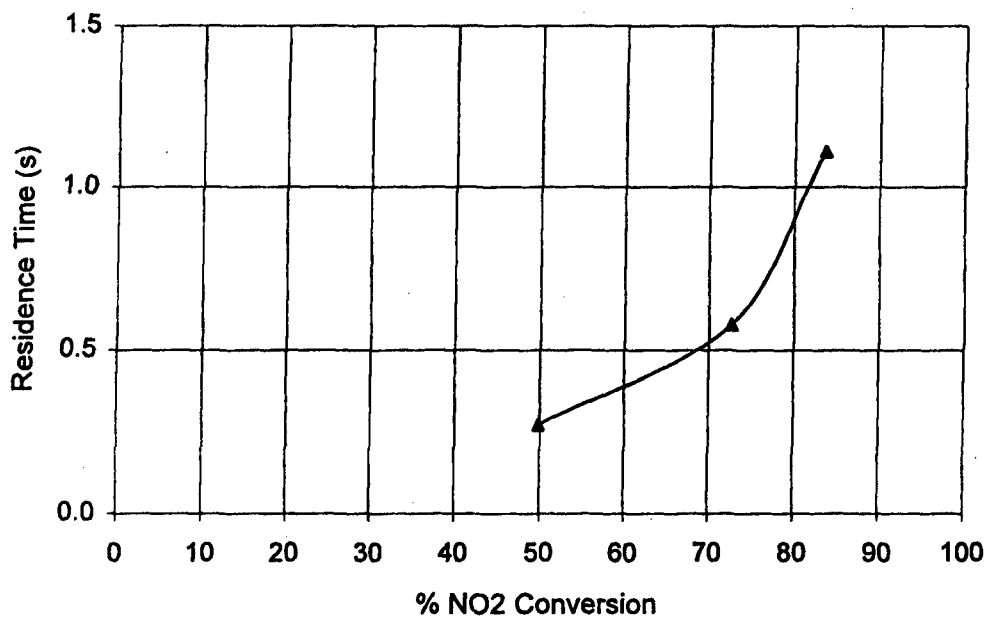

**Figure 27. NO-to-NO₂ Conversion at 700° F with a
Special Oxidation Catalyst**

NO-to-NO₂ Conversion with Ozone. In efforts to increase the NO-to-NO₂ conversion efficiency of the system, the use of ozone injection was studied. For this work, an ozone generator was rented from Osmonics of Phoenix, Arizona. A series of laboratory tests were run using a combination of catalyst exposure and ozone injection, and then with ozone injection alone. It soon became apparent during these tests that ozone will very effectively convert NO in a simulated exhaust gas into NO₂. As a result, testing was concentrated on ozone injection alone.

A number of tests were performed with various ozone-to-NO molar ratios. The results of these tests are presented in graphical form in Figure 28. The conversion reached 100 percent when the ratio was increased to at least 3. At ratios below 3, conversions dropped, but not significantly. For example, at a ratio of 0.4, the conversion was 82 percent. This suggests that the reaction that occurs is $\text{NO} + \text{O}_3 \rightarrow \text{NO}_2 + \text{O}_2$, and not $3\text{NO} + \text{O}_3 \rightarrow 3\text{NO}_2$, as one might desire.

A study of the economics of ozone injection for NO_x control was carried out, with the assistance of Osmonics. In a meeting with Osmonics personnel, it was learned that ozone generation will be very expensive for the large-scale systems that would be required for NO_x control. For example, for an ozone generator suitable for handling one stationary diesel-engine exhaust-gas stream at McClellan AFB, state-of-the-art equipment at a cost of \$500,000 or more would be required. The size of the equipment would also be enormous, covering most of the roof area of the diesel engine building.

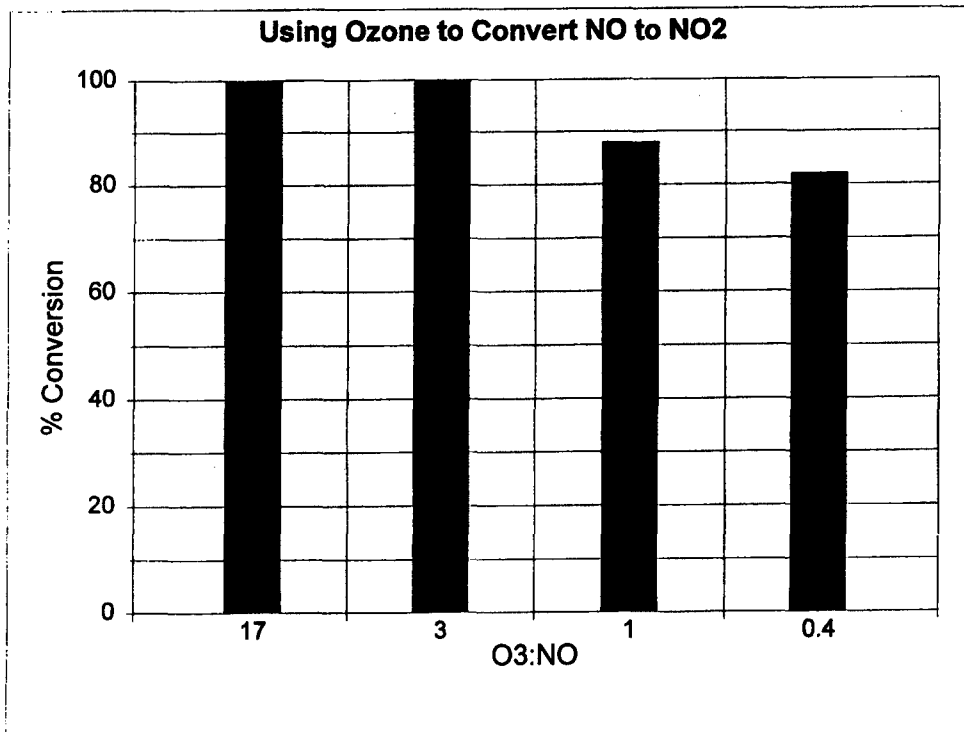

Figure 28. The Effects of Ozone:NO Ratio on NO-to-NO₂ Conversion Efficiency

Scrubbing NO₂ from Exhaust Gases. Two scrubbing systems, one involving a spray tower and a second involving a bubbling bed, were evaluated. The initial spray tower system was constructed primarily of glass. It possessed a scrubbing column that was 9 inches long and 1.2 inches in inside diameter. The column was partially filled with Raschig rings. The scrubbing liquid was sprayed into the top of the column. The gas being scrubbed entered at its base and exited at the top.

Water and an aqueous NaOH solution were used as the scrubbing medium in an initial series of experiments with the glass spray tower system. The inlet gas composition for these experiments was 70 ppm NO, 270 ppm NO₂, 14 wt% oxygen and balance nitrogen. The scrubbing medium flow rate was 0.23 liters per minute. All experiments were carried out at 77°F. Examples of data that were collected are provided in Table 14 below.

TABLE 14. INITIAL SCRUBBING TEST RESULTS

<u>Run No.</u>	<u>Scrubbing Medium</u>	<u>Gas Flow Rate (lpm)</u>	<u>NO₂ Removal (Percent)</u>	<u>NO Removal (Percent)</u>
1	H ₂ O	1.0	51	15
2	H ₂ O	2.0	37	8
3	H ₂ O	4.0	29	5
4	H ₂ O + 0.05m NaOH	4.0	37	30

The experimental results showed that water alone is not an effective scrubbing medium for NO, although it can remove up to about 50 percent of the NO₂ present. The addition of NaOH to the scrubbing water improved scrubbing performance.

Following the laboratory spray tower experiments, a laboratory bubbling-bed reactor system and a process development unit (PDU) spray tower system were designed, constructed and installed. Some of the water and water-NaOH scrubbing experiments were then repeated in the larger equipment.

The laboratory bubbling-bed reactor was a plastic column 4 feet high and 2 inches in diameter. It was filled partially with the scrubbing medium before each test, and during each test, the simulated exhaust gas was bubbled through the bed. For tests involving a solid medium (carbon), wire mesh was installed inside the column about 4 inches from the bottom to support the medium.

The PDU spray tower was also constructed of plastic. The tower was over 15 feet high and 8.25 inches in inside diameter. Like the laboratory spray tower, it was filled with Raschig rings. A photograph of the tower appears in Figure 29; a sketch of the unit is shown in Figure 30. A series of entry ports were placed along the length of the tower to allow sampling at different levels during test runs.

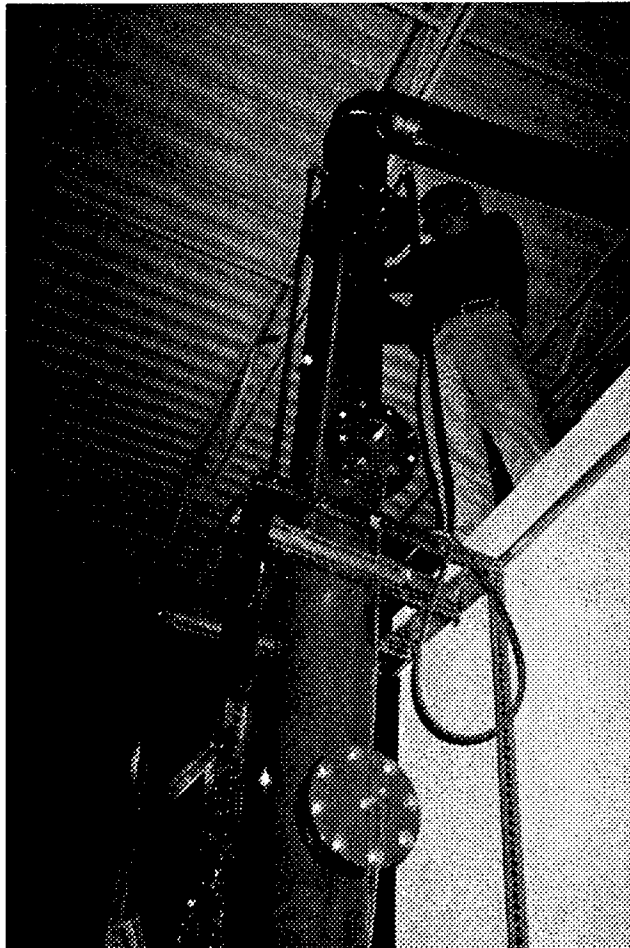

Figure 29. Conducting a Test Run with the PDU Spray Tower

The results of the initial runs with both the bubbling-bed reactor and the PDU spray tower confirmed the earlier results from the laboratory spray tower. NO_x removals with water alone were poor, and NO_x removals with water plus NaOH were better than with water alone. In all cases involving NaOH, the NaOH addition to water was 20 grams per liter.

Additional bubbling-bed tests were performed with Na₂S and with activated carbon additions to the water-plus-NaOH solution. In these cases, 2 grams of Na₂S or 400 grams of activated carbon were added to 3 liters of solution. The activated carbon was saturated with NO_x before use in the reactor to reduce the possibility of NO_x sorption by the carbon during the run. The results of tests with these materials and the results of tests with water and water-NaOH alone are summarized in Table 15. Excellent removals of both NO and NO₂ were seen when additions of Na₂S were made to the bubbling reactor. Additions of activated carbon appeared to improve NO₂ reduction, but did not remove much NO.

Although the results with the bubbling bed were very promising, work shifted to the PDU spray tower because the PDU spray tower was closer to commercial size, it presented a lower pressure drop in processing waste gases, and it, too, had shown promising results. A two-phase research effort was then carried out. In the first phase, the effects of other additives to the scrubbing water on NO₂ reduction was investigated. In the second phase, the use of saturated activated carbon as a catalyst to convert NO into NO₂ was coupled with scrubbing in the tower to determine what NO and NO₂ reduction potentials could be achieved.

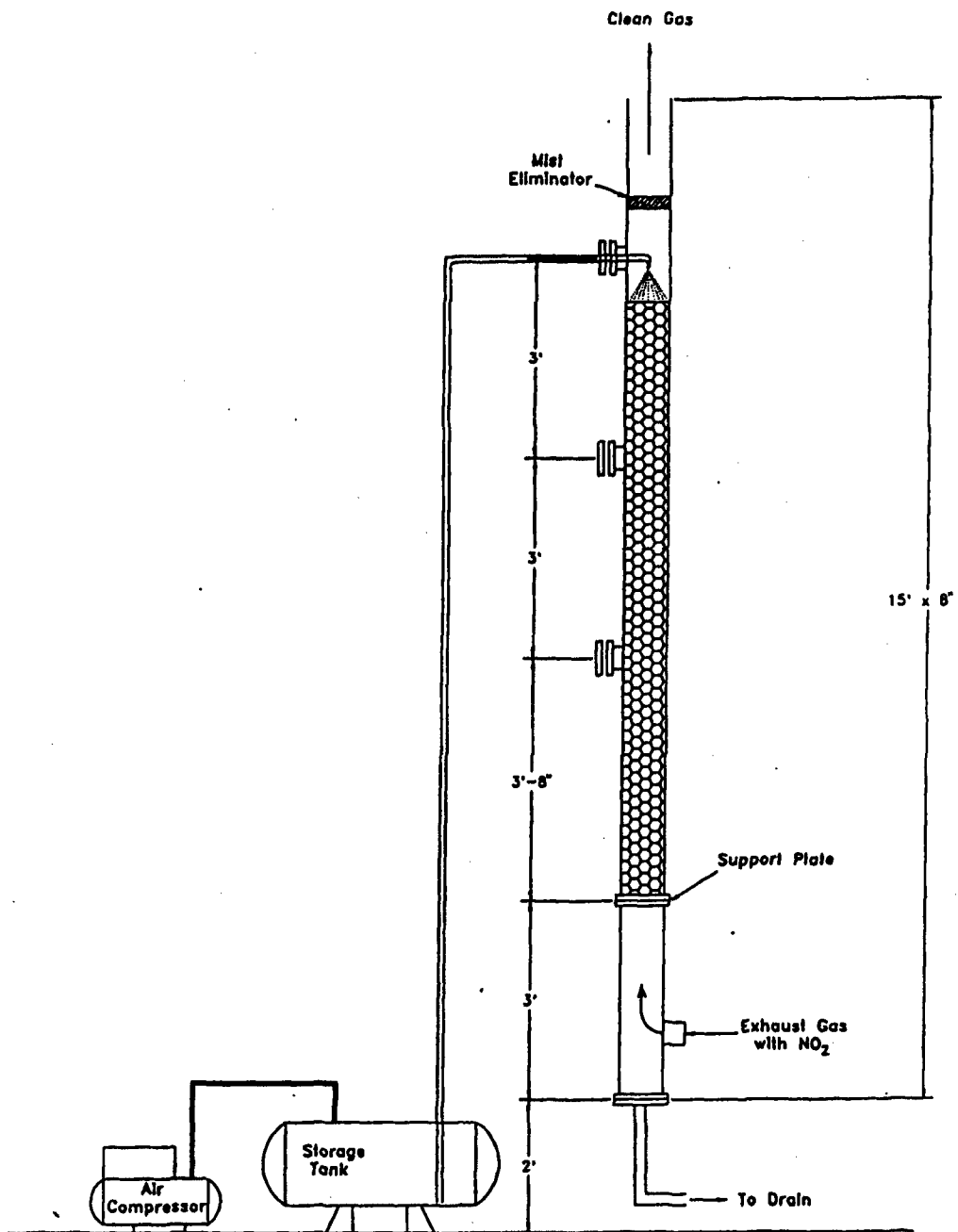

Figure 30. Sketch of the Laboratory PDU Scrubbing System

TABLE 15. ADDITIONAL SCRUBBING TEST RESULTS

SPRAY TOWER TESTS						
	<u>Gas Vel.</u> <u>(sft/min)</u>	<u>NO In</u> <u>(ppm)</u>	<u>NO₂ In</u> <u>(ppm)</u>	<u>NO Rem.</u> <u>(%)</u>	<u>NO₂ Rem.</u> <u>(%)</u>	<u>NOx Rem.</u> <u>(%)</u>
H ₂ O	60	130	360	-25	19	7
H ₂ O + NaOH	35	136	380	80	43	53
	60	60	330	46	36	38
BUBBLING BED TESTS						
	<u>Gas Vel.</u> <u>(sft/min)</u>	<u>NO In</u> <u>(ppm)</u>	<u>NO₂ In</u> <u>(ppm)</u>	<u>NO Rem.</u> <u>(%)</u>	<u>NO₂ Rem.</u> <u>(%)</u>	<u>NOx Rem.</u> <u>(%)</u>
H ₂ O	15	250	30	12	5	11
	24	0	260	-	54	54
H ₂ O + NaOH	12	20	340	80	59	60
	24	5	290	100	56	56
H ₂ O + NaOH + Na ₂ S	12	20	345	62	95	93
	24	10	290	90	96	96
H ₂ O + NaOH + Activated Carbon	12	325	45	10	10	10
	12	0	175	-	98	98
	24	0	260	-	69	66

Of the new additives examined, NaSH, Na₂CO₃, and Ca(OH)₂ demonstrated good NO₂ removal during scrubbing. A series of experiments were performed to examine how well the products of ozone injection (NO₂ and residual ozone) can be scrubbed from the exhaust-gas stream. When ozone was introduced to the exhaust gas prior to scrubbing, the ozone converted 80 percent of the NO to NO₂ and the scrubber then removed more than 92 percent of the NO₂ and more than 96 percent of the residual ozone. The data collected in these experiments appear in Appendix A-5. Of the new additives, NaSH yielded particularly good results and was investigated in depth. Scrubbing runs were performed at different scrubbing rates. Also, different column lengths were considered. The results of these runs are plotted in Figure 31. From these runs it was possible to determine the column length needed to achieve near-100-percent NO_x reduction with a commercial spray tower scrubber. For example, for a facility to handle the total stationary diesel-engine exhaust-gas stream at McClellan AFB, an 18-foot column would be needed.

With the technologies developed in the project, it was possible to determine or to project total NO_x removals achievable with combined NO-to-NO₂ conversion and scrubbing processes, when processing a typical diesel engine exhaust gas that was observed at McClellan AFB (490 ppm NO and 50 ppm NO₂). Graphs showing the levels of NO_x entering and leaving the scrubber under low humidity (dry air) and high humidity (atmospheric air) conditions are provided in Figure 32. The atmospheric air case is more representative of real-life conditions. From these graphs, it can be seen that about 72-percent NO_x removal can be expected with processes developed. The graphs also clearly indicate the importance of the NO-to-NO₂ conversion process. If NO-to-NO₂ conversions could be increased to near 100 percent (as was seen with ozone injection), NO_x removals can be expected to exceed 95 percent.

2. Activated Carbon Sorption of NO_x

A clean prefilter was installed on the filter cart before examining the cart's use in controlling emissions at the stationary diesel engine facility. The carbon beds on the cart were relatively fresh, having been exposed to exhaust gases for only about 4 hours beforehand. After the cart was connected to the stack by means of a long, flexible pipe, the exhaust gases were directed to the cart. Two tests were performed totaling 3.5 hours. The photograph in Figure 33 shows the taking of data during the run. A summary of test conditions and results is provided in Table 16. The appearances of prefilters before and after the tests are shown in Figure 34.

The filter cart clearly was effective in capturing both NO and NO₂ from the stationary diesel exhaust gases. From the appearances of the prefilter before and after the runs, the prefilter was also effective in capturing particulates.

3. Recycling of Exhaust Gases

The results of recycling the stationary diesel engine exhaust gases back through the diesel engine were noteworthy. The results are summarized in Table 17. Marked changes in the composition of the exhaust gases occurred almost immediately. NO_x levels were reduced significantly, from an average 532 ppm to 70 ppm. However, CO levels rose dramatically from 80 ppm to 780 ppm and the levels of smoke emissions rose in a similar manner. Recycling, however, did not appear to affect the engine's performance to any large extent. Engine temperatures remained about the same, and the energy output was reduced only slightly.

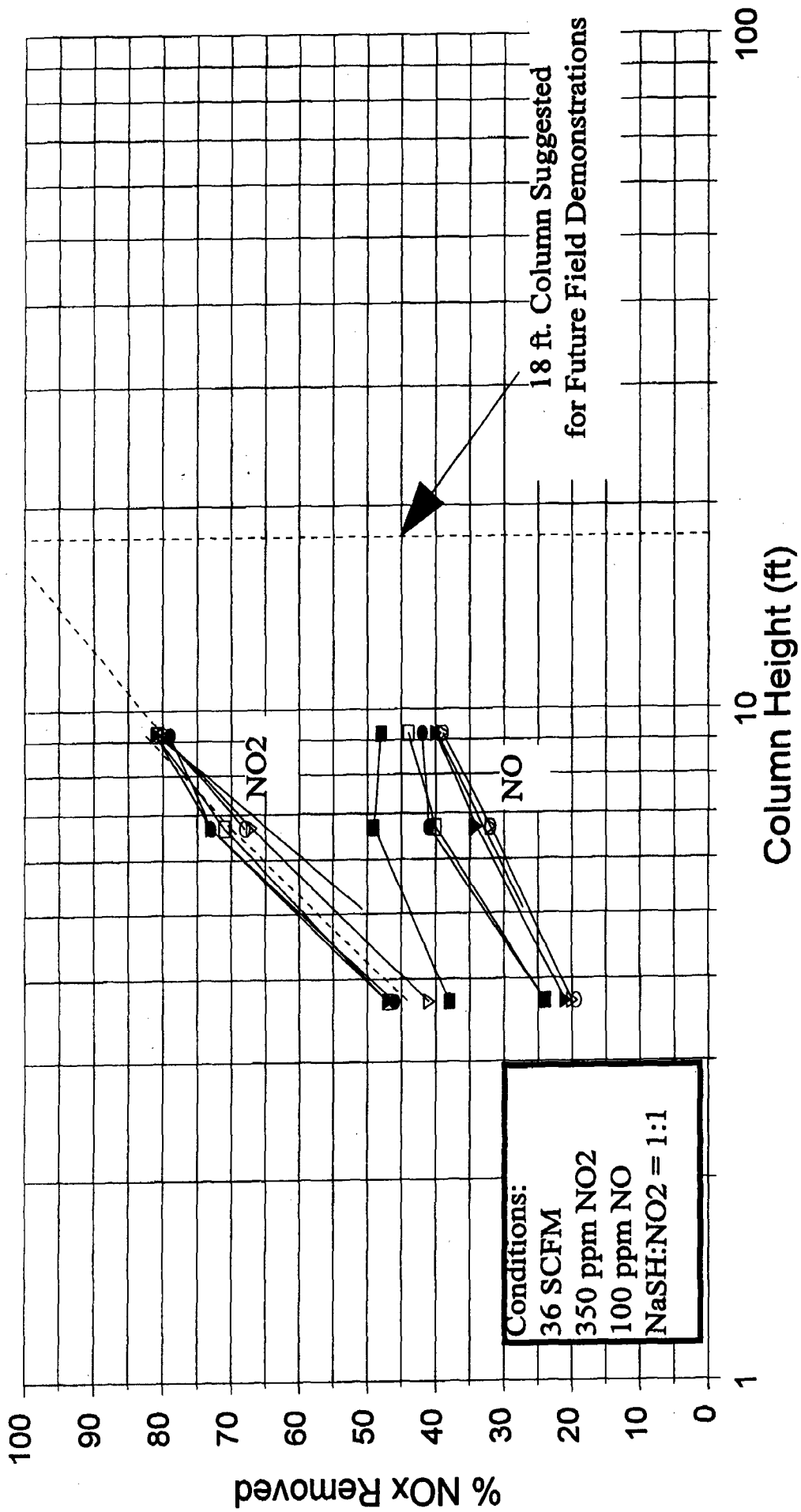

Figure 31. NOx Removals with the PDU Spray Tower Using a NaSH Additive with a Projection for 100 Percent NO₂ Removal

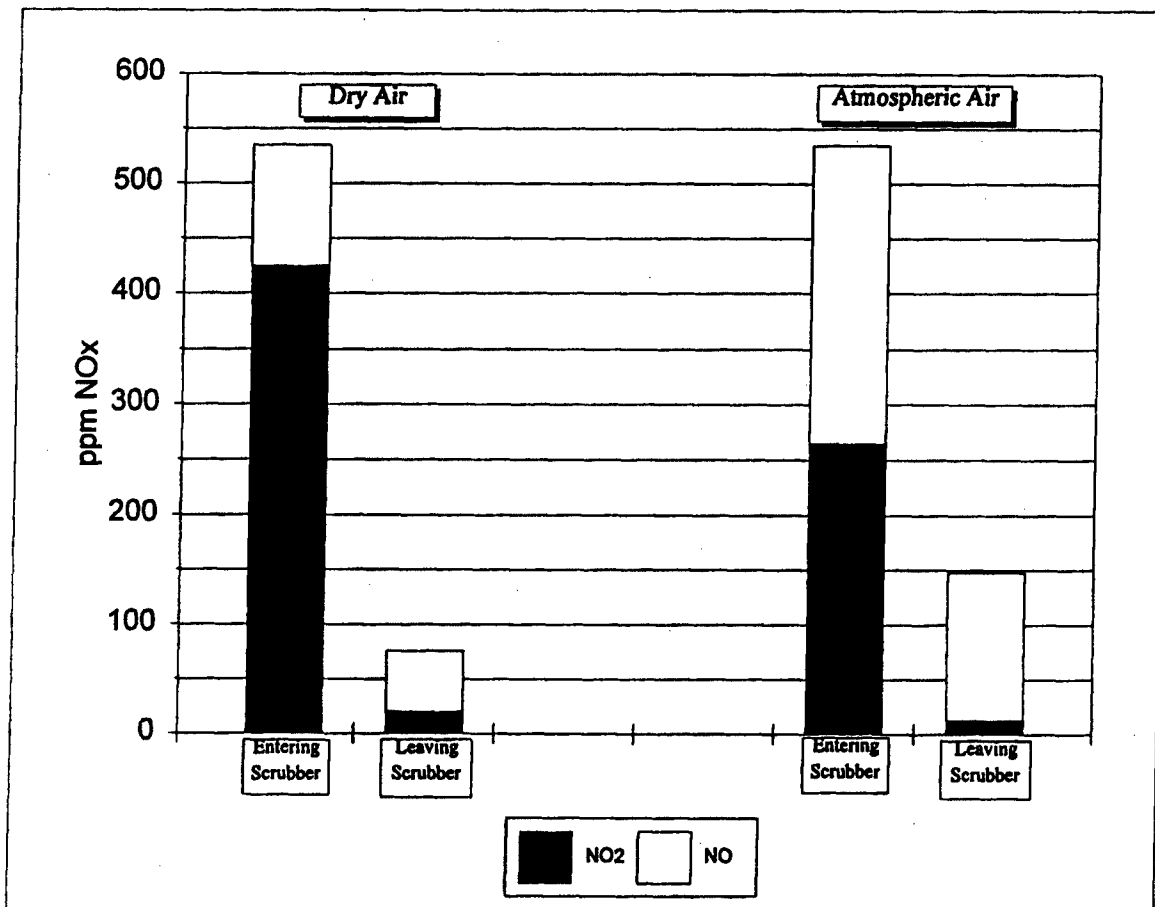

Figure 32. NO_x Levels of Exhaust Gases Entering and Leaving Sorbtech's NO_x Scrubber in Laboratory Tests

Note: The NO_x level of the simulated untreated stationary diesel exhaust gas was 540 ppm (490 ppm NO and 50 ppm NO₂). The exhaust gas was passed through a NO-to-NO₂ activated carbon catalyst bed and then through the scrubber. The composition of the gas entering the scrubber was assumed to be the same as the gas leaving the catalyst bed. The dry air case involved simulated gases supplied entirely from commercial gas cylinders. The atmospheric air case employed typical moist room air that was compressed.

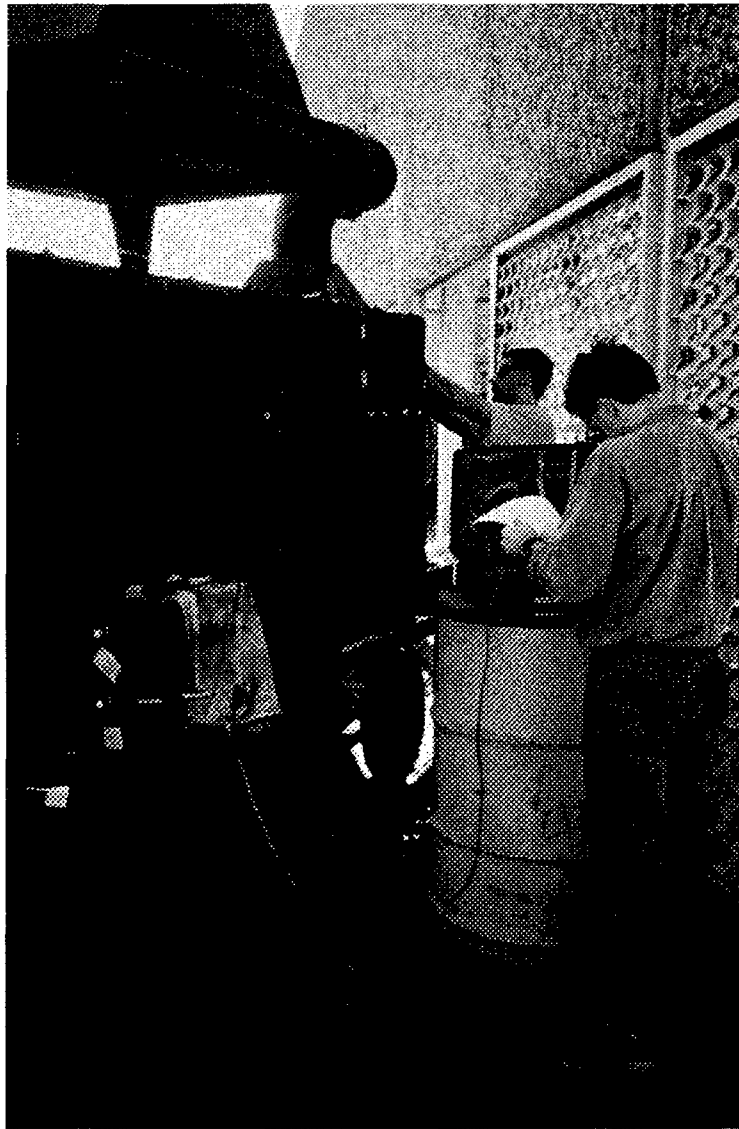

Figure 33. Recording Measurements During a Stationary Diesel-Engine Run with the Mobile Filter Cart

TABLE 16. AVERAGE NO_x REMOVALS DURING STATIONARY DIESEL-ENGINE TESTS

	Time (min)	Flow Rate (SCFM)	% NO Removed	% NO ₂ Removed
Test 1	70	475	100	100
Test 2	130	640	98	100

**TABLE 17. RESULTS OBSERVED IN
RECYCLING DIESEL-ENGINE EXHAUST GASES**

Recycling Test

	Baseline	Recycling
NO	452 ppm	58 ppm
NO ₂	80 ppm	12 ppm
O ₂	15.4%	8.4%
CO	80 ppm	780 ppm
Comb.	0.00%	0.03%

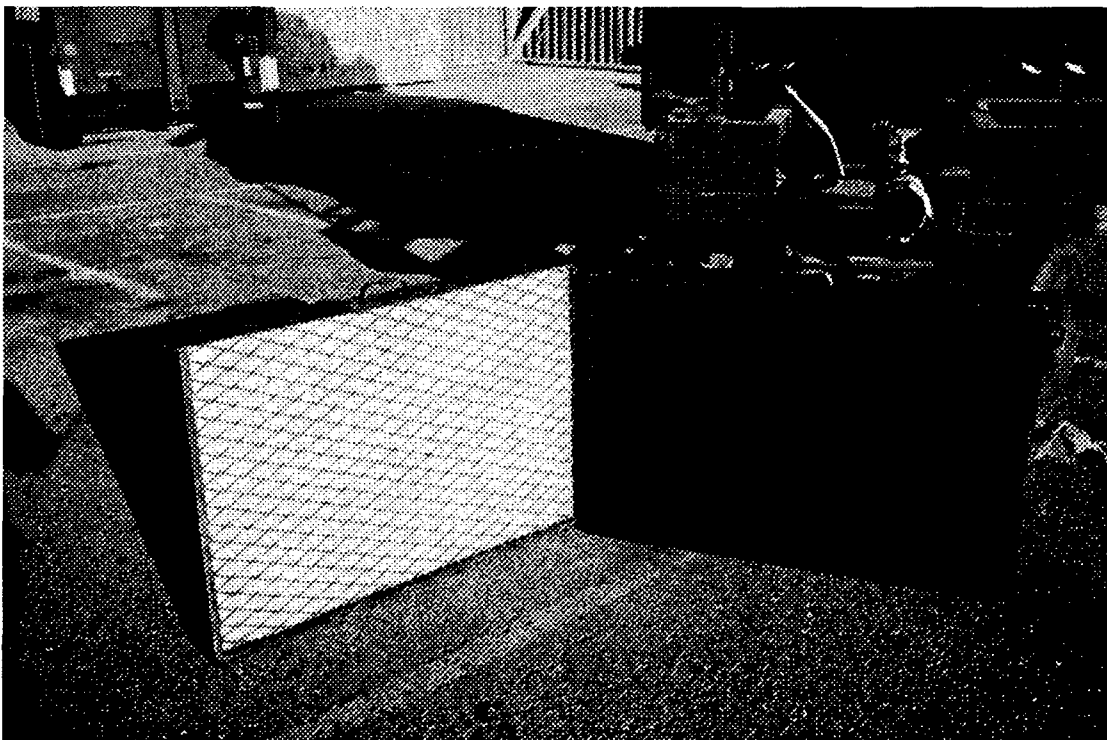

**Figure 34. The Appearance of the Prefilter Before and
After the Stationary Diesel-Engine Run**

D. NO-to-NO₂ AND WET SCRUBBING COSTS

An analysis similar to that made for the Filter Cart/NO_x Destructor was performed for the NO-to-NO₂/wet scrubbing approach. For this analysis, a single system was considered, one suitable for installation at McClellan AFB treating the exhaust gases from one of three existing stationary diesel generators. The total NO_x removed annually was assumed to be 20 tons. The stationary diesel generators at McClellan AFB are operated intermittently and are generally on line less than 50 percent of the time. If operated continuously for one year at 75 percent load, each would produce about 40 tons of NO_x. A summary of the analysis appears in Table 18.

The estimated capital costs for a NO-to-NO₂ Catalyst System and for a NO_x Scrubbing System are \$40,000 and \$53,000, respectively. Operating the combined systems annually will require about \$29,000. On this basis, the NO_x-control cost for the combined system will be about \$1,878 per ton of NO_x controlled.

**TABLE 18. ESTIMATED CAPITAL AND OPERATING COSTS –
NO-to-NO₂ CONVERSION WITH WET SCRUBBING**

CAPITAL COSTS - NO-to-NO₂ Conversion

Basis: One system treating one stationary diesel engine at McClellan, operating 50 percent of the time and generating 1300 SCFM of exhaust gases.

Cost Breakdown:

Catalyst	\$ 30,000
Catalyst Chambers	2,000
Coupling	1,500
Assembly & Engineering	2,000
Installation	1,000
Profit	<u>3,500</u>
Total	\$ 40,000

Capital Cost/Ton NOx Captured

Capital Cost Plus Financing

Capital Cost	\$ 40,000
Cost of Capital (20 yr @ 6%)	<u>33,570</u>
Cost over 20 yr	\$ 73,570

With 20 TPY NOx Removed:

Capital Cost Component = \$184/T NOx Removed

CAPITAL COSTS - SCRUBBING SYSTEM

Basis: One system treating one stationary diesel engine at McClellan, operating 50 percent of the time and generating 1300 SCFM of exhaust gases.

Cost Breakdown:

Packed-Bed Scrubbing Column	\$ 12,000
Fan	3,500
Recirculation System	4,000
Interconnecting Ductwork	3,500
Chemical Feed System	7,000
Instrumentation & Control Panel	10,000
Storage Tanks	3,000
Assembly & Engineering	2,000
Installation	3,000
Profit	<u>5,000</u>
Total	\$ 53,000

Capital Cost/Ton NOx Captured

Capital Cost Plus Financing

Capital Cost	\$ 53,000
Cost of Capital (20 yr @ 6%)	<u>44,480</u>
Cost over 20 yr	\$ 97,480

With 20 TPY NOx Removed:

Capital Cost Component = \$244/T NOx Removed

ANNUAL OPERATING COST - TOTAL SYSTEM

Basis: One system treating one stationary diesel engine at McClellan, operating 50 percent of the time and generating 1300 SCFM of exhaust gases.

Quantity of NOx Removed Annually: 20 tons/Stationary Engine

Cost Breakdown:

Catalyst Replacement (10%)	\$ 3,000
General Maintenance (2% of Capital Costs)	1,860
Scrubber Chemicals	18,500
Water	4,000
Electricity	1,300
Misc. Expenses	<u>340</u>
Total	\$ 29,000

COST PER TON OF NOx REMOVED

	<u>Cost/T of NOx Removed</u>
Capital Cost - NO-to-NO ₂ Conversion	\$ 184
Capital Cost - Scrubbing System	244
Operating Cost - Total System	<u>1,450</u>
Total Cost per Ton of NOx Removed*	\$ 1,878

*Note that this cost does not include particulates' removal, except for those particulates that are removed during scrubbing.

VI. DIESEL BUSES AND TRUCKS

A. BACKGROUND

Motor vehicles of many types are employed at military bases. Automobiles, trucks, buses, mobile cranes, and fire engines are examples. Most automobiles are gasoline-powered; most other vehicles are diesel-fueled. With the exception of some electricity-powered units, all vehicles produce exhaust gases with some undesirable pollutants. NO_x and smoke particles are of particular concern.

An objective of the project was to determine if the exhaust gases from diesel vehicles can be cleansed of NO_x and smoke particles by using the filter technologies developed for mobile diesel generators by Sorbent Technologies Corporation, and a new particle-trap design developed by Converter Technology, Inc., of Michigan Center, Michigan. Two diesel vehicles, a 1984 International bus, used to transport airmen and civilian workers around McClellan AFB, and a White Motors Road Boss 2 truck, were selected for study. Photographs of these two vehicles appear in Figures 35 and 36.

B. APPROACHES

The bus and the truck were treated separately. The approach that was pursued consisted of the following steps:

Diesel Bus Application

- 1) Characterization of the exhaust gases from the bus.
- 2) Design, construction, and installation of a bus filter system.
- 3) Procurement and installation of a Converter Technology particle trap.
- 4) Testing of the bus filter and trap.

Diesel Truck Application

- 1) Characterization of the exhaust gases from the truck.
- 2) Design, construction, installation, and testing of a particulate filter.
- 3) Design, construction, installation, and testing of a NO_x filter.

C. DISCUSSION OF RESULTS

1. Diesel Bus Application

Gas Characterizations. The exhaust gases emitted by the diesel bus were characterized while the bus remained stationary and when it was moving. Sampling and measurement ports were placed at several locations. These included before and after the muffler, about 8 feet beyond the muffler, and, when the NO_x filter was installed, before and after the NO_x-filter bed. Measurements of temperature, gas composition, pressure change, and gas flow rate were made. Data were taken during the operation of the bus over roads on the Air Force base and around the neighboring area. Tests were made while running at a variety of speeds and going uphill, downhill, and on flat terrain.

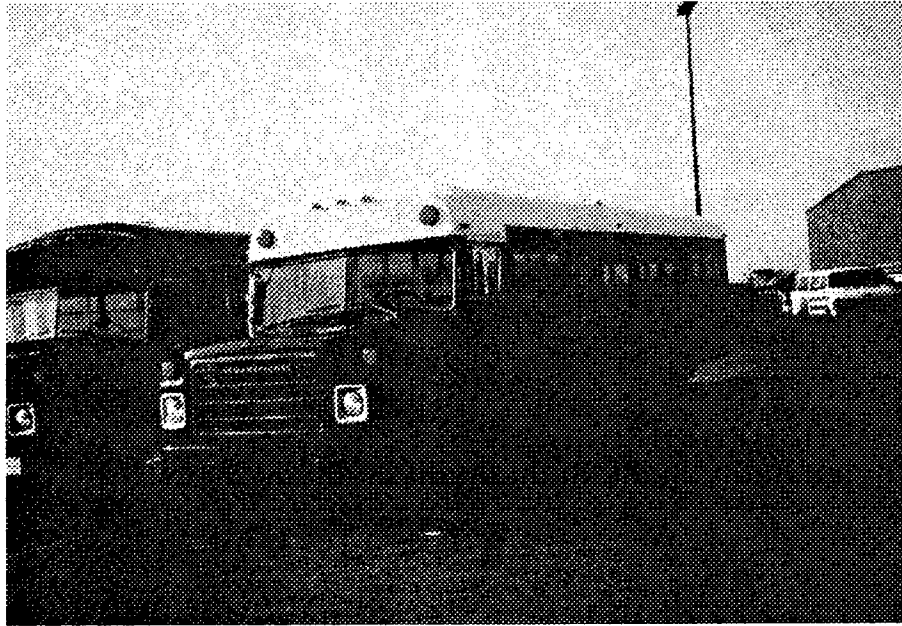

Figure 35. Bus at McClellan AFB Employed in Studies

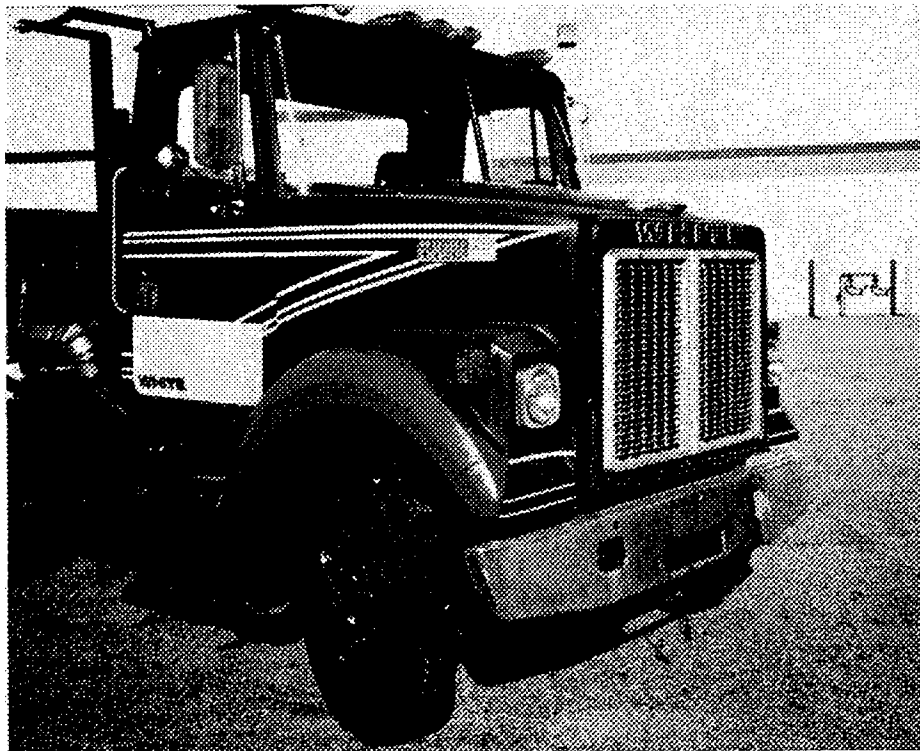

Figure 36. Diesel Truck Employed in Studies

A summary of baseline data that were collected on the bus is given in Figure 37. These data describe the exhaust-gas characteristics that were seen before the installation of pollution-control equipment. Typically, the exhaust gas contained about 275 to 525 ppm NO_x. Perhaps surprising was the observation that the NO_x level of the exhaust gas decreased with increased bus and engine speed. With increased bus speed, the temperature of the exhaust gases rose markedly (from 258°F at 15 mph to over 650°F at 55 mph). The volume of exhaust gases released by the bus also increased markedly. As a result, the total NO_x released at high speed rates and when the bus was laboring up a hill was very high, and significantly higher than that observed when the motor was at idle. The CO level of the exhaust gases was fairly constant at about 190 ppm at all bus speeds up to 55 mph. However, at about 55 mph, the CO level increased abruptly to about 630 ppm. No SO₂ was noted in the exhaust gases until a speed of the vehicle increased to 55 mph. At that point, a trace amount (10 ppm) was detected. As one might expect, the oxygen level of the exhaust gases decreased with increasing gas temperatures. The moisture level of the gas was relatively low. The gas contained about 3 percent H₂O during the day of the measurements, and this level did not vary significantly with engine load. Some additional raw data obtained during the run appear in Appendix A-6.

Efforts to collect and measure the particulate levels of the exhaust gases were not successful owing to the pulsating nature of the waste gas stream. In all cases, the filter papers in the sampling devices ruptured during testing. Accurate measurements were not possible.

Particulate Removal. Nearly any device exposed directly to diesel-engine exhaust gases will eventually become coated or covered with black, sticky, carbon-rich particulates that are present in the gases. With some devices, such as an SCR catalyst honeycomb structure, a coating will generally completely mask the surface and render the unit useless. With other systems, such as the activated carbon beds employed in the project, coatings can be less disruptive, but can eventually become a problem. The activated carbon beds will trap many particles present in the gases. After a time, the beds become clogged and NO_x-capture performance deteriorates. Regeneration of the beds only partially corrects the problem. It is for this reason that a device or a prefilter to capture particulates before NO_x removal is believed imperative.

Particle traps are mechanical devices that are designed to physically capture particles from gas streams and, in most cases, to burn and destroy them. Although a few particle traps are currently being evaluated in real-life applications, none has as yet received widescale acceptance. In a separate program, the Air Force has supported the development of a trap unit by Converter Technology, Inc. A smaller unit of a similar design was obtained from Converter Technology for this project.

The Converter Technology particle trap was installed on a bus at McClellan AFB. The installed unit is shown in Figure 38. The trap replaced the existing muffler on the bus.

NO_x-Removal. Also placed on the bus was an activated carbon filter assembly (See Figure 39). The filter assembly was installed around the existing back bumper of the bus. It was composed of six separate filters of the same size employed on the filter cart (approximately 14 inches by 21½ inches by 8 inches thick). A 0.5-inch thick commercial fiberglass prefilter was placed in front of each carbon bed to capture particulates circumventing the particle trap and to prevent the unlikely event of sparks entering the carbon bed. The end of the tail pipe of the bus was modified to distribute exhaust gases evenly over the six installed filters.

Diesel Bus (84B 1895)

RPM	MPH	Temp. (F)	ACFM	SCFM	NO (ppm)	NO2 (ppm)	NOx (ppm)	O2 (%)	CO (ppm)	SO2 (ppm)	Comb. (%)
950	5	227	213	153	400	114	514	17.6	182	0	0
1050	15	258	230	160	370	98	468	17.4	160	0	0
1300	25	317	338	214	390	90	480	16.4	135	0	0
1600	35	392	484	279	312	72	384	15.7	172	0	0
2250	45	436	610	335	231	44	275	15.6	190	0	0
2786	55	654	939	415	241	32	273	12.9	631	10	0.01

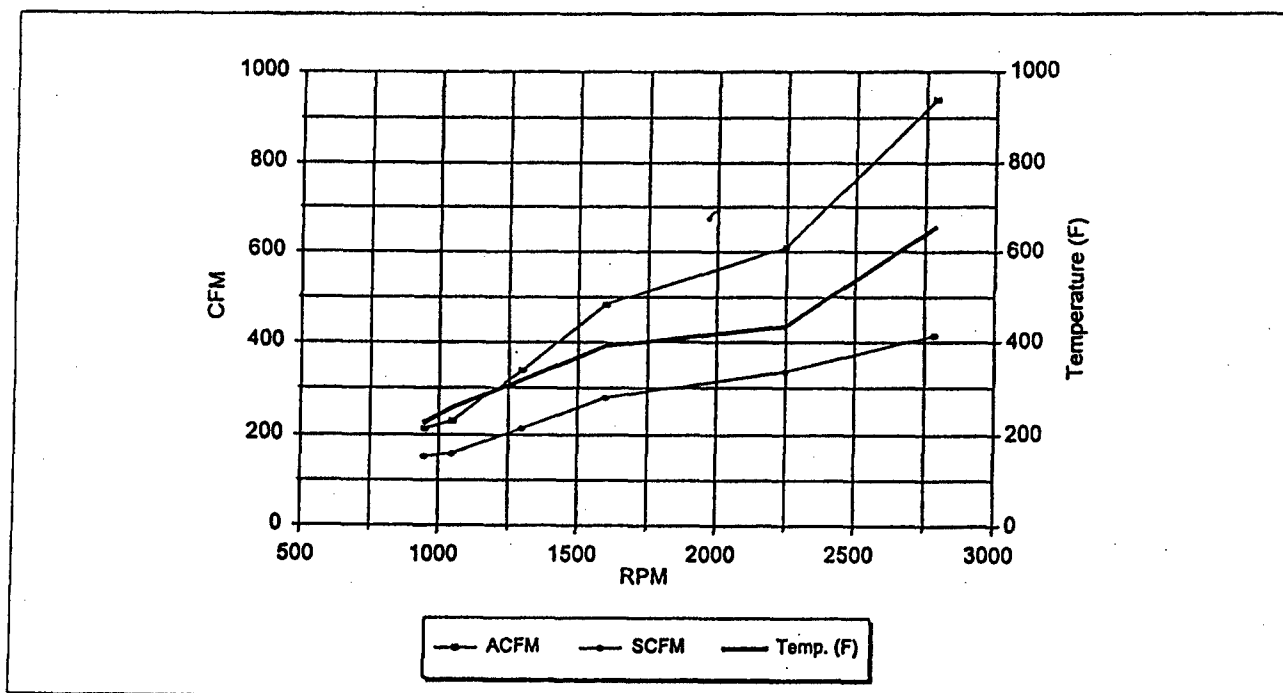
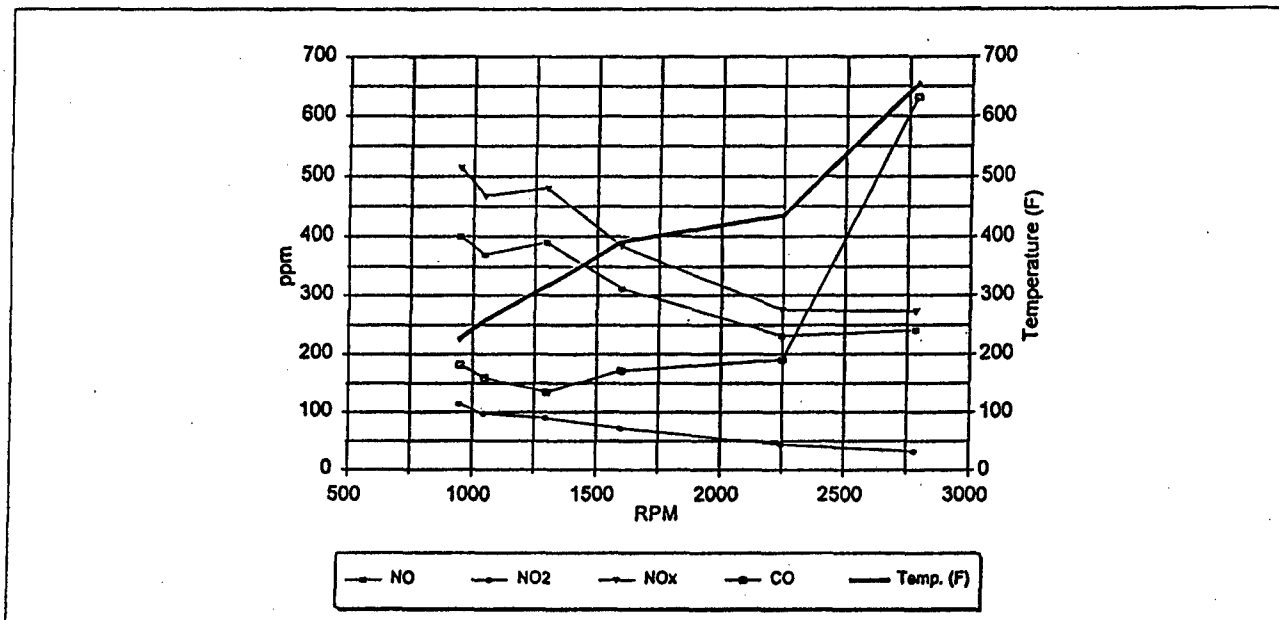

Figure 37. Baseline Data Obtained for a McClellan AFB Bus

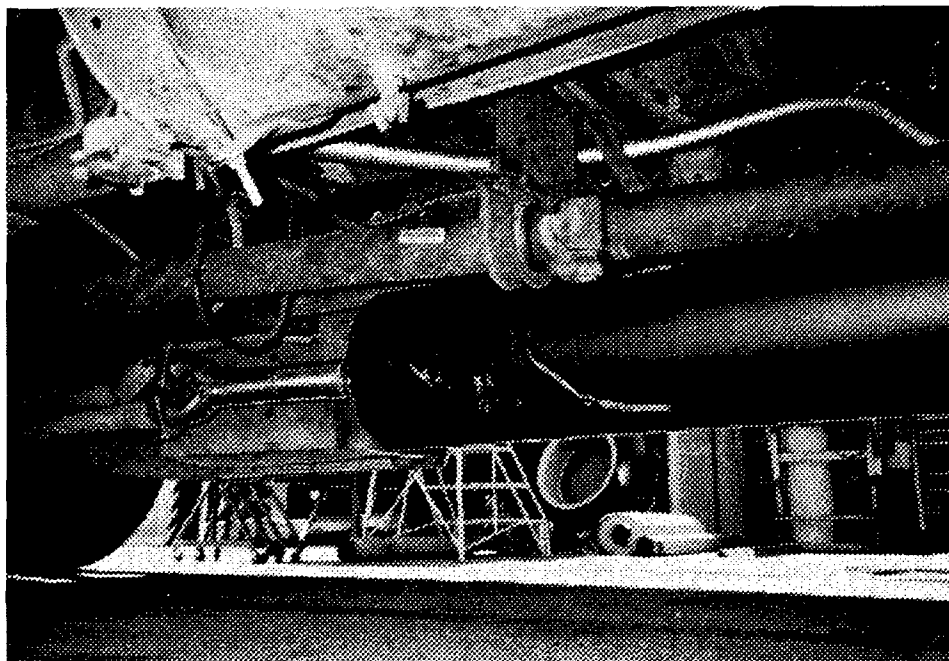

Figure 38. The Converter Technology Filter Trap Installed Beneath the Bus



Figure 39. Installing the NOx Filters on a Bus at McClellan AFB

Performance Testing. The performances of the installed units were examined after one week and after two months of continuous use. Measurements were made with the bus stationary and with the bus moving at different speeds. A summary of NO_x test results is given in Table 19.

TABLE 19. SUMMARY OF BUS NO_x-FILTER TESTS

	Temp. at Filter <u>(°F)</u>	Avg. NO Removal <u>(%)</u>	Avg. NO ₂ Removal <u>(%)</u>	Avg. NO _x Removal <u>(%)</u>
<u>After One Week</u>				
<u>Stationary Tests</u>				
Idle	94	99	96	98
1500 rpm	140	99	97	98
2000 rpm	157	95	94	95
2750 rpm	216	82	88	83
<u>On-Road Tests</u>				
20 mph	205	64	78	66
25 mph	217	55	83	59
55 mph	275	7	17	8
<u>After Two Months</u>				
	Temp. at Filter <u>(°F)</u>	Avg. NO Removal <u>(%)</u>	Avg. NO ₂ Removal <u>(%)</u>	Avg. NO _x Removal <u>(%)</u>
<u>Stationary Test</u>				
Idle	147	85	100	96
<u>On-Road Tests</u>				
15 mph	189	90	100	97
30 mph	212	85	100	97

The pressure drop across the NO_x-filter system was relatively low initially, less than 3 inches W.G., but it increased later during the two-month testing period to as high as 11 inches W.G. at high speeds. The pressure drop across the particle trap was very high, over 30 inches W.G., at all times.

The particle trap did not appear to perform well. The particle-collection ability of the particle trap could not be assessed quantitatively because of the particle-sampling problems described earlier (rupturing of the sampling discs before the trap due to pulsing). However, its performance could be judged on the basis of the appearance of the prefilters in front of the carbon beds and on the appearance of particulate samples collected on discs after the particle trap (the pulsing was significantly less after the particle trap). The prefilters were heavily encrusted with soot during the test period, so much so that soot periodically flaked off from the prefilter surfaces and collected as a large pile of loose material at the base of the prefilters. The appearance and quantities of particle samples collected after the particle trap were similar to those of particle samples removed from raw exhaust gases discharged from an AGE.

The results of the NO_x-filter tests showed that the NO_x filters performed well at all times, except when the exhaust gas temperatures rose above about 250°F. This occurred at high speeds and when the bus climbed steep grades. The addition of the particle trap was observed to place a high degree of back pressure on the bus engine, which, in turn, caused the engine to run much hotter than normal. The result was a higher-temperature exhaust gas that was detrimental to NO_x-capture performance. A surprising observation was that the NO_x-filter appeared to capture NO_x slightly more effectively after two months of use than after its initial use. The build-up of mostly carbon soot on the prefilter may have played a part in the improved performance.

The activated carbon filters remained on the bus for about three months. They were then removed and were returned to Sorbtech's laboratories. Tests on samples of the exposed carbon showed that they were heavily saturated with NO_x.

2. Diesel Truck Application

For the diesel truck application, separate systems were studied for particulates removal and for combined particulates and NO_x removal. The particulate-control technology that performed so well on the mobile filter cart was applied to the diesel truck. Special structures to hold the two filter systems were designed, constructed, and installed on the bus.

Gas Characterizations. Prior to the installation of particulate-control and NO_x-control systems on the diesel truck, the truck's exhaust gases were characterized. The measured temperatures and compositions of the exhaust gases are provided in Figure 40. The measurements indicated that the temperature of the exhaust gases increased with engine speed and reached 513°F when the engine speed was 2500 RPM, which is equivalent to about 50 miles per hour truck speed. An almost identical temperature was observed for the bus exhaust gas under the same conditions. The NO_x levels of the exhaust gases from the truck were significantly lower than those from the bus at low engine speeds, but they approached the bus's NO_x levels at high engine speeds. The truck, however, produced and released higher levels of CO than the bus. As for the bus, a small amount of SO₂ (maximum 20 ppm) was seen in the truck's exhaust gases.

Diesel Tractor

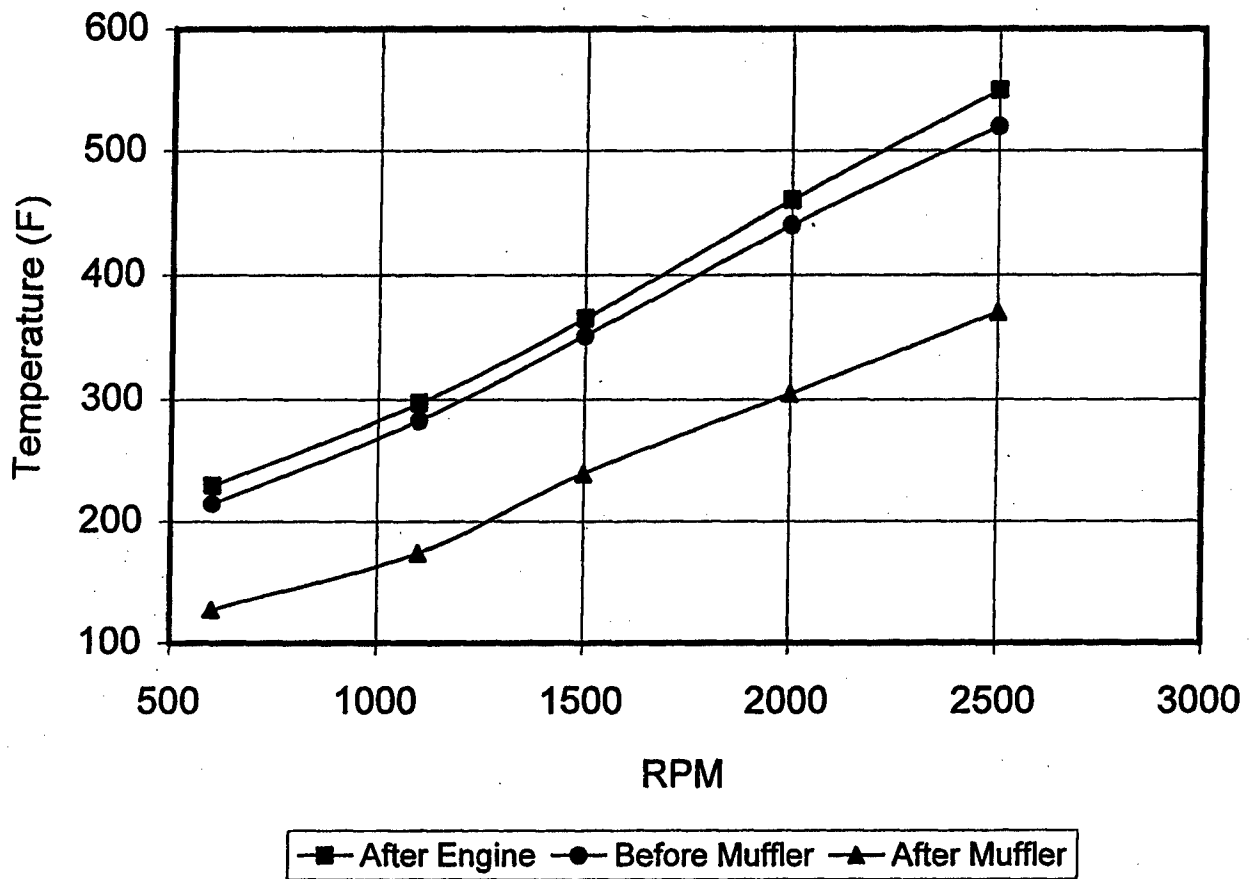

RPM	After Engine Temp (F)	Before Muffler Temp (F)	After Muffler Temp (F)
600	230	215	128
1100	297	283	174
1500	366	352	240
2000	460	440	305
2500	550	520	371

Figure 40. Conditions Observed During the Normal Operation of a Diesel Truck

Particulates Removal. Two vermiculite-silica filter-system designs were examined. The first was a stand-alone unit employed only to capture particulates. The second was a system in which a vermiculite-silica filter was combined as a unit with a NOx filter. The stand-alone vermiculite-silica filter unit is shown in Figure 41. It was installed at the end of the exhaust-gas line, replacing the existing muffler. The unit was rectangular in shape and held two, parallel vertical sorbent beds, each 60 inches by 30 inches and 2.5 inches thick. Exhaust gases entered at the bottom of the unit, passed up between and through the beds, and exited through perforations in the unit's sides.

A single horizontal vermiculite-silica filter bed was used with the NOx filter. The vermiculite-silica bed dimensions were 96 inches by 30 inches and 3 inches thick. The activated-carbon bed was 96 inches by 30 inches and 6 inches thick.

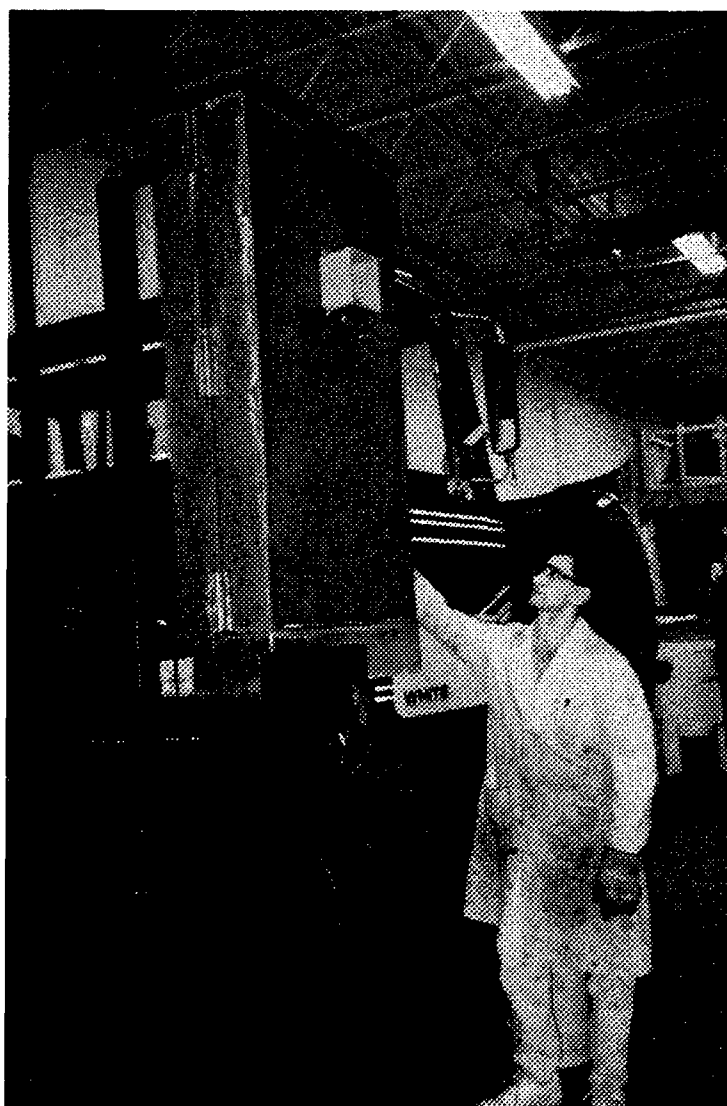

Figure 41. Small-Particle Filter for Diesel Truck Studies

NOx Removal. The NOx filter unit is shown in Figure 42. It was purposely designed and constructed to be oversized to allow long-term use before regeneration is required and to be adaptable in the future for possible regeneration-in-place of the sorbent. During its use, exhaust gases entered the top of the unit, first passed through the vermiculite-silica bed for particle capture, then passed through an activated-carbon bed for NOx capture, and finally exhausted through the bottom of the unit to the atmosphere. The exhaust gases were treated as they came from the engine. However, they passed through 20 to 34 feet of steel tail pipe before arriving at the filter unit. For some tests, cooling water or an ice bath was employed to cool the tail pipe.

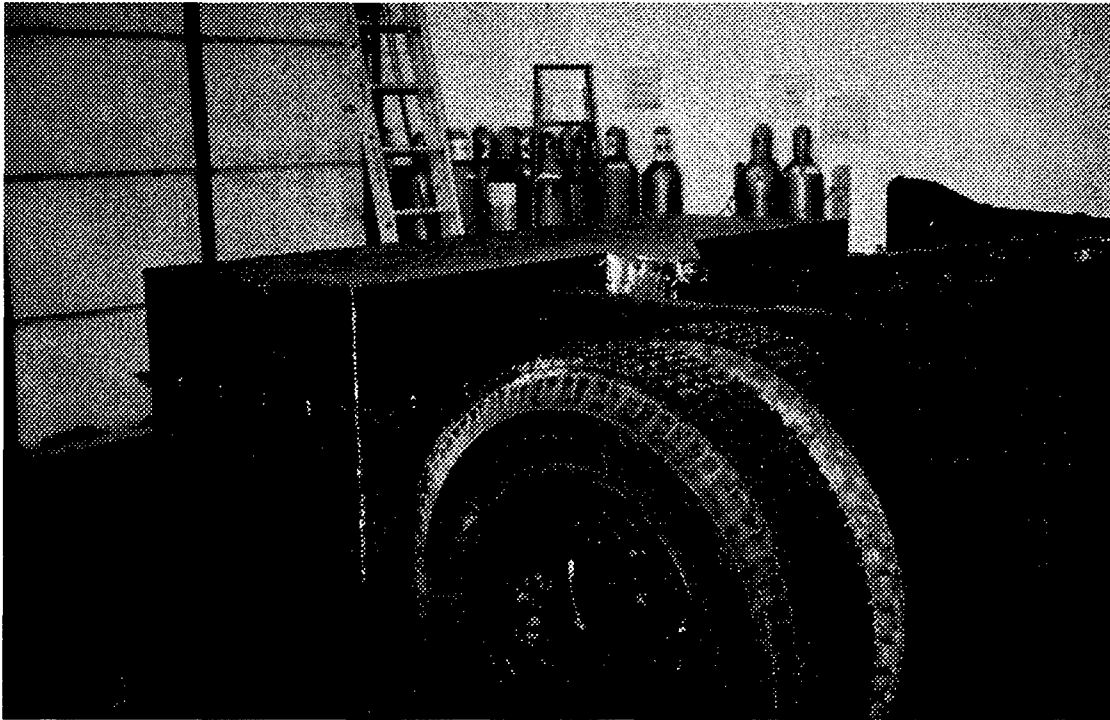

Figure 42. Combined Particulates NOx Control System as Applied to a Diesel Truck

Performance Testing - Particulates Capture. A 50-hour test run was performed with the vertical particulate-filter apparatus in place. Measurements of temperatures, pressures, flow rates, and compositions of gases into and out from the filters were made during the run. More than 95 percent of the time during the test, the engine was run at idle; at other times, the engine was operated at high engine speeds. Several observations were made during the run.

1. In reducing noise levels, the filter apparatus appeared to perform as well as, if not better than, the original muffler.
2. The capture rate of particulates (particles 0.2 microns or larger) with the new filters was 90 percent or more during the initial hours of usage; however, the rate fell off somewhat (to 50 percent) after 50 hours.

3. The filter apparatus at idle presented very little pressure drop. Initially, the pressure drop was 0.1 inch W.G. After 50 hours of particulate collection, the pressure drop increased to approximately 1.0 inch W.G.
4. Particulate capture was good both at idle and at high engine speeds.
5. The filter apparatus was designed to be easily opened and examined during the test runs. Surprisingly little particle deposition occurred on non-filter surfaces during the run. The filter faces, on the other hand, became progressively darker in color as run-time increased.

Performance Testing - NO_x Capture. A series of several test runs was performed with the horizontal NO_x filter in place. The truck's engine was run at different speeds, which resulted in gases of different temperatures and compositions. The relative humidity of the exhaust gases varied from about 16 to 45 percent. Although a special portable box enclosure was employed to reduce air entrainment during the collection and analysis of gases that exited the filter, some dilution of the outgoing gases occurred. Knowledge of the oxygen levels of the exhaust gases entering and leaving the filter, however, permitted the correction of NO_x values. Typical NO_x-removal data collected in tests are given in Table 20. The data show that the NO_x filter was effective in capturing NO_x. NO_x removals were typically 90-to-100-percent.

TABLE 20. NO_x REMOVALS IN TRUCK TESTS

Test No.	1	2	3	4
Testing Time (min)	120	20	25	10
Engine Speed	Idle	Idle	Idle	High
Engine Temp (°F)	216	220	220	304
Gas Temp at Filter (°)	89	113	107	153
Avg O ₂ In (%)	18.7	17.7	17.9	18.1
Avg O ₂ Out (%)	20.4	19.6	20.0	19.0
Avg NO In (ppm)	57	73	74	49
Avg NO Out (ppm)	3	3	0	0
% NO Removed*	86.0	91.8	100.0	100.0
Avg NO ₂ In (ppm)	24	31	32	13
Avg NO ₂ Out (ppm)	0.5	1	0	0
% NO ₂ Removed*	97.9	93.5	100.0	100.0

*Corrected for air (oxygen) dilution

VII. INCINERATORS AND NATURAL-GAS-FIRED BOILERS

A. BACKGROUND

Incinerators of two general types can be found at military sites: (1) conventional incinerators and (2) specialty incinerators. Conventional incinerators typically burn mixtures of household, commercial and industrial trash. Two conventional incinerators exist at Fort Dix. There, trash from both the Fort Dix Army Base and McGuire AFB is burned. The trash includes household wastes, office wastes, and hospital wastes. An example of a specialty incinerator is a unit that can be found at McClellan AFB. This unit burns hydrocarbons that are recovered from contaminated soils and is being used in the clean up of a Superfund site.

The exhaust gases of several natural-gas-fired boilers at McClellan AFB were examined. In all cases, the exhaust gases were relatively clean. Before the study, McClellan AFB had recognized high NO_x levels in the exhaust gases from its natural-gas-fired boilers and had installed flue-gas recycling systems to reduce NO_x. These systems appear to be effective in reducing NO_x levels. On the basis of the relatively low NO_x levels that were measured, no further NO_x-control work with the boilers was performed by Sorbent Technologies Corporation.

The hydrocarbon incinerator at McClellan AFB was initially selected for study. However, problems with the operation of the unit made it unavailable for use during the time of the study. An incinerator at Fort Dix was therefore substituted.

The overall objective of the incinerator study was to determine the technical feasibility of applying the activated-carbon sorption technology to the Fort Dix incinerator exhaust-gas stream to control NO_x emissions.

B. APPROACHES

The incinerator studies were limited to laboratory work and to slipstream trials at Fort Dix. The portable filter-bed system employed in AGE tests at Wright-Patterson AFB earlier was modified and was used in slipstream trials.

1. Fort Dix Exhaust-Gas Characterization

Exhaust-gas measurements were made through an existing sampling port on the side of the stack of Incinerator 2 at Fort Dix. Baseline data that were collected are given in Appendix A-7. The temperatures of the exhaust gases at the sampling port varied with operating conditions, but generally were in the range of 120 to 140°F. The average total gas flow rate was 10,000 SCFM. The gas contained 40 ppm NO, 14.7 percent O₂, and no measurable NO₂, SO₂, CO and combustibles (See Table 21).

A 35-SCFM slipstream of exhaust gases was then extracted through this same port and drawn to the ground for processing. The sampling port, which was located 70 feet above the ground, provided the only easy access to the exhaust gases. The slipstream gases were conducted to the portable filter-bed system on the ground through 4-inch-diameter straight and flexible metal duct. The duct, in part, acted as a heat exchanger, dropping the gas temperatures from about 120°F to 70°F.

TABLE 21. TYPICAL INCINERATOR EXHAUST GAS CONDITIONS

Temp. at Stack (°F)	NO (ppm)	NO ₂ (ppm)	O ₂ (%)	CO (ppm)	SO ₂ (ppm)	Comb. (%)
140	40	0	14.7	0	0	0

2. Design and Use of a Portable Filter-Bed Test Apparatus

The existing portable filter-bed test apparatus was modified to better seal off the tops and bottoms of sorbent beds that were employed in the apparatus. In the earlier tests, small amounts of exhaust gas were occasionally observed to pass around the sorbent beds, instead of passing through them. This problem was solved by placing high-temperature rubber gasket material between the beds and the apparatus walls. Improved gas-duct connections were also installed to reduce the probability of leaks.

A flow diagram for the incinerator slipstream tests is shown in Figure 43. Exhaust gases taken from the stack were drawn through a wire-mesh demister before entering the filter-bed test device. The demister was effective in condensing and removing water droplets. Unlike in the earlier AGE tests, no prefilter materials were employed in the incinerator tests. A blower at the end of the system drew gas through the system and expelled the processed gas to the atmosphere. A blind flange on the blower outlet controlled the flow rate of the gas being processed.

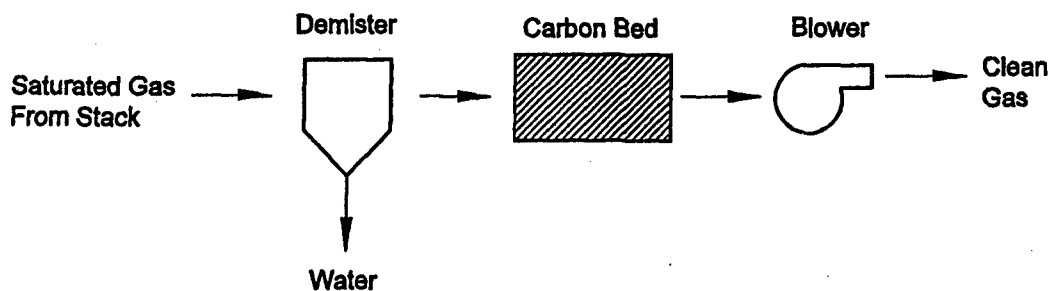

Figure 43. Flow Diagram for Incinerator Slipstream Tests

3. Test Results

Two different 12-inch beds of activated carbon were tested at Fort Dix. The first was a bed of fresh activated carbon; the second was activated carbon that was pre-exposed to NO_x-containing exhaust gases at McClellan AFB and was partially regenerated at Sorbent Technologies Corporation's laboratories. Each bed was exposed for 2 hours to the slipstream exhaust gases. Figure 44 shows the testing of the incinerator gases.

The fresh, virgin activated carbon captured 100 percent of the NO_x in the incinerator exhaust gases during the entire 2-hour test period. The partially regenerated carbon, on the other hand, removed nearly 100 percent of the NO_x initially, but, after a while, became significantly less effective. Over the 2-hour test period, it captured an average of about 56 percent of the NO_x in the exhaust gases. A summary of the results is given in Table 22.

C. DISCUSSION OF RESULTS

The incinerator exhaust gases at Fort Dix today appear relatively innocuous with respect to NO_x, CO and SO₂. Neither CO nor SO₂ were detected in the exhaust gases, and NO_x levels were in the range of 40 to 55 ppm. Earlier measurements indicated that HCl levels are typically less than 0.03 ppm.

Based on the slipstream test results, the use of the activated carbon filter developed in the project can be expected to reduce the NO_x levels of the incinerator exhaust gases to near zero.

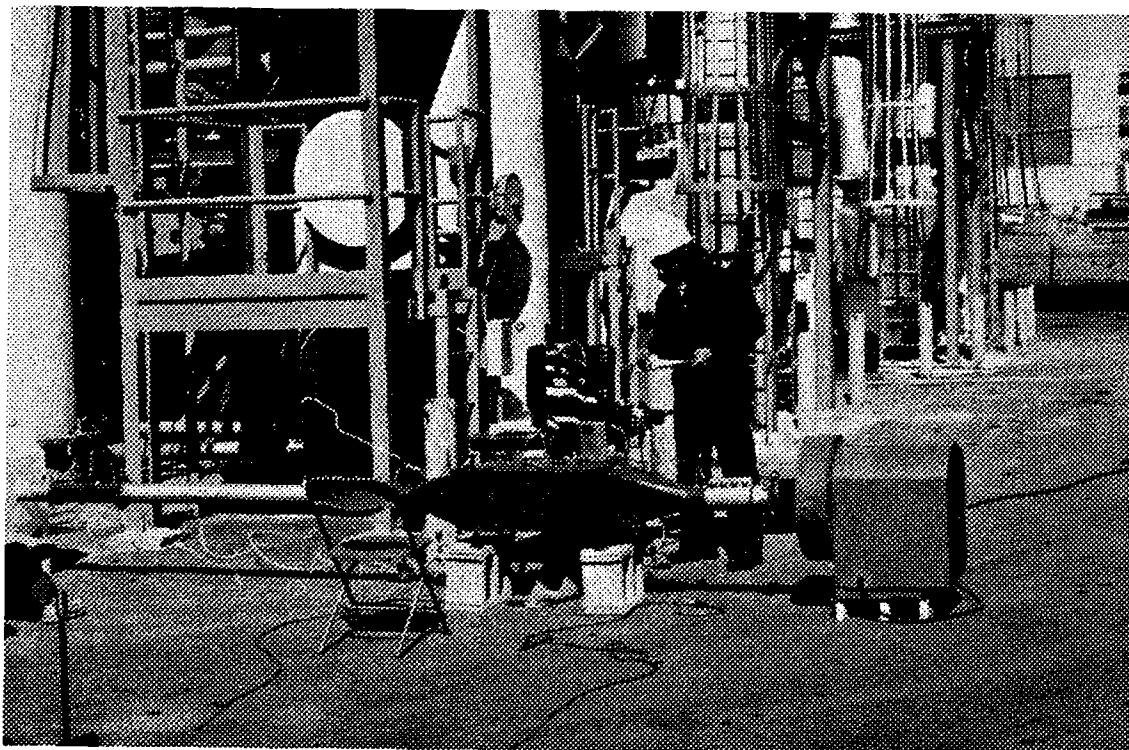

Figure 44. Employing the Portable Filter-Bed Test Apparatus on a Slipstream of Incinerator Exhaust Gas

TABLE 22. INCINERATOR EXHAUST-GAS FILTER TEST RESULTS

Virgin Carbon

Time (min)	SCFM	T1 (F)	T2 (F)	T3 (F)	NO (ppm)		NO2 (ppm)		O2 (%)		Comb. (%)		% NOx Removed
		Exhaust	Demister	Bed	In	Out	In	Out	In	Out	In	Out	
0	35	118	74	83	43	0	0	0	16.0	16.0	0.1	0.1	100%
30	35	116	72	93	55	0	0	0	16.0	16.0	0.1	0.1	100%
50	35	112	70	88	49	0	0	0	16.0	16.0	0.1	0.1	100%
85	35	120	71	99	49	0	0	0	16.0	16.0	0.1	0.1	100%
120	35	120	71	99	43	0	0	0	16.0	16.0	0.1	0.1	100%

Partially Regenerated Carbon

Time (min)	SCFM	T1 (F)	T2 (F)	T3 (F)	NO (ppm)		NO2 (ppm)		O2 (%)		Comb. (%)		% NOx Removed
		Exhaust	Demister	Bed	In	Out	In	Out	In	Out	In	Out	
0	35	117	58	67	51	4	0	0	16.0	16.0	0.1	0.1	92%
25	35	120	82	67	43	9	0	0	16.0	16.0	0	0	79%
53	35	125	69	80	50	19	0	0	16.0	16.0	0	0	62%
94	35	118	73	80	50	40	0	0	16.0	16.0	0	0	20%
120	35	118	73	80	49	36	0	0	16.0	16.0	0	0	27%

VIII. CONCLUSIONS AND RECOMMENDATIONS

A. CONCLUSIONS

On the basis of the results of the project, the following observations and conclusions were made:

1. A small filter composed of Magsorbent (magnesia coated onto vermiculite particles) was designed, constructed and installed on a radiant-tube heater. This filter effectively reduced NO_x levels 17 to 25 percent in exhaust gases from the heater. However, a careful examination of old NO_x emissions data disclosed that the present tube heaters at McClellan AFB currently meet NO_x emissions standards.
2. Two major sources of NO_x emissions at McClellan AFB are the jet engine test cells and both stationary and mobile diesel engines.
3. In treating diesel-engine exhaust gases, NO_x removals approaching 100 percent were achieved using a special activated carbon filter.
4. The carbon filter material sorbed from 7 percent (in the field) to 15 percent (in the laboratory) of its weight in NO_x before becoming saturated. Upon full regeneration, it typically regained 99 percent of its sorption capacity.
5. An effective regeneration process was developed for activated carbon saturated with NO_x. During regeneration, essentially all captured NO_x was released from the carbon as a concentrated stream, and this NO_x was destroyed with methane or propane in the presence of a proprietary magnesia catalyst.
6. Regenerating carbon filters in place and simultaneous destruction of the released NO_x was demonstrated with ease in a large laboratory system. NO_x destructions exceeding 99.9 percent were achieved with few or no traces of unreacted methane in the exit gases.
7. A filter for capturing and removing particulates, especially sub-micron particles, was developed and was successfully demonstrated. The filter, comprising vermiculite, silica, and/or magnesia, performed well as a prefilter in front of activated carbon beds.
8. With CO present at levels above 250 ppm in exhaust gases, small amounts of NO_x reduction occurred in vermiculite prefilter material. With magnesia present, SO₂ capture occurred. The prefilter was particularly effective in capturing PM-2.5 particles. Both solid and liquid particulates were captured with the prefilter.
9. TCLP test results indicated that the prefilter, when saturated with particulates and requiring replacement, can be disposed of as a normal non-hazardous waste material. Options for handling degraded activated carbon include returning the carbon to the manufacturer for reprocessing or burning it as a fuel.
10. The activated carbon filter and the particulate prefilter were incorporated into a mobile filter cart for use in controlling diesel engine exhaust gases from aerospace ground equipment (AGE) and other equipment. Average NO_x removals observed during four-hour runs with the mobile filter cart were as follows:

<u>APPLICATION</u>	<u>Average % NO Removal</u>	<u>Average % NO₂ Removal</u>
72-kW, 60-Hz AGE*	96.6	99.1
60-kW, 60-Hz AGE	92.6	100.0
Mobile Auxiliary Power Unit	95.0	98.8
CO ₂ -Blaster Compressor		
Idle	96.8	100.0
Normal Load	92.3	96.5
Stationary Diesel Engine	99.0	100.0

*SO₂ removal averaged 95.6% during the run.

Particulate capture efficiencies were typically 90 to 100 percent.

11. The prefilter activated-carbon system was installed and successfully demonstrated on a diesel-powered bus and on a diesel-powered truck. The NO_x- and particulate-removal efficiencies observed in bus and truck applications were similar to those observed with the mobile filter cart. Only when exhaust gas temperatures rose above 230°F did NO_x removals decrease significantly.
12. Preliminary tests on an industrial incinerator exhaust gas at Fort Dix indicated that the prefilter activated-carbon system should perform satisfactorily in incinerator exhaust-gas applications.
13. A new technology was developed for reducing the NO_x levels of exhaust gases produced by large stationary diesel engines. The technology is a two-step process consisting of first converting the NO in the exhaust gases into NO₂, and then scrubbing the NO₂ from the stream. Two catalysts were developed for NO-to-NO₂ conversion, with a combination of the two yielding about 90-percent conversion in the presence of oxygen. High NO-to-NO₂ conversions were also demonstrated with ozone injection, but ozone production was observed to be very expensive.
14. An effective NO₂ scrubbing process was also developed that resulted in the near-complete removal of NO₂, along with some NO. The new technology was successfully demonstrated through the PDU stage.

B. RECOMMENDATIONS

Based upon the results observed in the project and upon related R/D performed by Sorbent Technologies Corporation, the follow-on activities described below are recommended:

1. The mobile filter cart in the project was designed to demonstrate the technical feasibility of the NO_x-control concept. As a result, little attention was given to the cart's overall appearance. Technically proven now, the cart should be stylized. The ability to regenerate the beds in place should also be incorporated into its design. A conceptual next-generation design that should be considered is shown below:

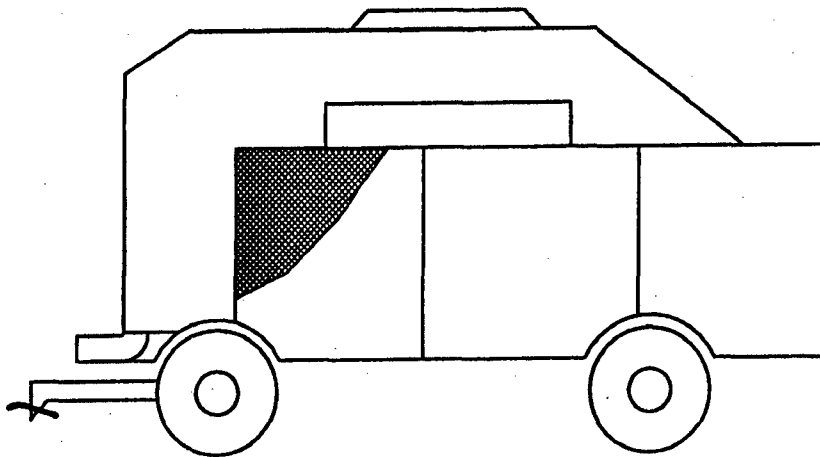

Streamlined Filter Cart with Regeneration-in-Place Capability

2. The NO-to-NO₂/NO₂-scrubbing process developed and demonstrated in the project is a simple, highly promising solution to the NO_x problems of the large stationary diesel engines. A large-scale demonstration of the new technology appears warranted at this time.
3. Continued development and demonstration work in applying the new prefilter and carbon filter to trucks, buses, and incinerators should be pursued.

REFERENCES

1. S. G. Nelson, D. A. Van Stone, R. G. Ellis, C. X. Zhang, and B. C. Cianciolo, Jet Engine Test Cell Filter Demonstration at McClellan AFB, AL/EQ-TR-1997-0015, Armstrong Laboratory, Tyndall AFB, Florida, December, 1996.
2. S. Nelson Jr., Pilot-Scale Testing of a New Sorbent for Combined SO₂/NO_x Removal, Final Report, Prepared for the Ohio Coal Development Office, June, 1994, PP 92-95.
3. A. M. Rubel, S. N. Ahmed, and J. M. Stencil, The Use of Activated Carbon for Selective Capture of NO_x from Combustion Flue Gas, Paper presented at the 1993 AIChE Summer National Meeting in Seattle, Washington, August 15-18, University of Kentucky, 1993.
4. S. G. Nelson, R. A. Babyak, and B. C. Cianciolo, Development and Demonstration of the Mobile Filter Cart, 90th Annual Meeting A&WMA, Paper No. 97-MP5.02, 1997.
5. S. G. Nelson, D. A. Van Stone, and B. W. Nelson, Controlling Combustion-Source Emissions at Air Force Sites with a New Filter Concept, AL/EQ-TR-1994-0006, Armstrong Laboratory, Tyndall AFB, Florida, 1994.
6. S. G. Nelson and J. D. Wander, Control of NO_x and Other Pollutants at Jet Engine Test Cells, 89th Annual Meeting A&WMA, Paper No. 96-MP15A.03, 1996.
7. S. G. Nelson, R. A. Babyak, and J. W. Carroz, Diesel Engine Exhaust NO_x Reduction, 89th Annual Meeting A&WMA, Paper No. 96-TP15B.02, 1996.
8. A. Prasad, "Air Pollution Control Technologies for Nitrogen Oxides," The National Environmental Journal, May/June, 1995.
9. E. B. Myers Jr. and T. J. Overcamp, Oxidative Techniques for the Control of Oxides of Nitrogen, 90th Annual Meeting A&WMA, Paper No. 97-WP106.04.
10. B. J. Akridge, et al, Reduction of Nitrogen Oxides Emitted by Aerospace Ground Equipment at March AFB, 90th Annual Meeting A&WMA, Paper No. 97-TA364.01.
11. M. D. High and K. W. Blasch, Aerospace Ground Support Equipment Emissions Characterization, 90th Annual Meeting A&WMA, Paper No. 97-RA117.05.

APPENDICES

1	2	3
4	5	6
7	8	9
10	11	12

APPENDIX A-1

in

TYPICAL LABORATORY DATA
COLLECTED WITH THE HEATER FILTER

Time	Location	Temp. (F)	NOx		Oxygen		Velocity (sfpm)	% Removed
			In	Out	In	Out		
0	in	77	-	-	-	-	4300	-
30	in	444	12	-	17.7	-	-	-
53	1	125	12	11	17.7	18.0	-	8.33
54	2	135	12	12	17.7	18.3	-	0.00
55	3	168	12	9	17.7	18.8	-	25.00
56	4	146	12	9	17.7	18.5	-	25.00
57	5	148	12	9	17.7	18.2	-	25.00
57	6	157	12	12	17.7	18.4	-	0.00
57	7	162	12	9	17.7	18.6	-	25.00
58	8	161	12	9	17.7	18.8	-	25.00
58	9	170	12	9	17.7	18.5	-	25.00
59	10	168	12	9	17.7	18.2	-	25.00
59	11	171	12	9	17.7	18.6	-	25.00
60	12	174	12	12	17.7	18.3	-	0.00
68	in	490	33	-	17.6	-	-	-
72	1	150	30.5	28	17.6	18.1	-	8.20
73	2	156	30.5	25	17.6	18.4	-	18.03
74	3	205	30.5	25	17.6	18.5	-	18.03
75	4	165	30.5	25	17.6	18.3	-	18.03
76	5	165	30.5	23	17.6	18.7	-	24.59
77	6	196	30.5	25	17.6	18.0	-	18.03
78	7	187	30.5	22	17.6	18.5	-	27.87
79	8	181	30.5	20	17.6	18.8	-	34.43
80	9	197	30.5	25	17.6	18.2	-	18.03
81	10	194	30.5	22	17.6	18.6	-	27.87
82	11	193	30.5	22	17.6	18.3	-	27.87
83	12	188	30.5	20	17.6	19.0	-	34.43
84	in	500	28	-	17.6	-	-	-
* Burner flame turned down slightly								
90	1	171	26	22	-	18.4	-	15.38
91	2	167	26	20	-	18.5	-	23.08
92	3	170	26	20	-	18.9	-	23.08
93	4	190	26	22	-	18.6	-	15.38
94	5	184	26	20	-	18.7	-	23.08
95	6	208	26	20	-	18.6	-	23.08
96	7	200	26	20	-	18.8	-	23.08
97	8	192	26	17	-	19.0	-	34.62
100	9	206	26	20	-	18.7	-	23.08
102	10	200	26	17	-	19.0	-	34.62
103	11	195	26	20	-	18.8	-	23.08
105	12	192	26	17	-	19.2	-	34.62

Avg. = 17.36%

Avg. = 22.95%

Avg. = 24.68%

APPENDIX A-2

1	2	3
4	5	6
7	8	9
10	11	12

in

FIELD DATA COLLECTED
WITH THE HEATER FILTER

Time	Location	Temp. (F)	NOx (ppm)		Oxygen (%)		CO (ppm)		SO2 (ppm)		Velocity (sfpm)	Notes
			In	Out	In	Out	In	Out	In	Out		
Sleeve in open position, filter not attached												
0	in	480	18	-	16.5	-	77	-	0	-	-	CO2: 3.3% (calculated)
5	in	480	20	-	16.1	-	11	-	0	-	-	
8	in	480	20	-	15.9	-	11	-	0	-	3800	
15	in	556	20	-	15.8	-	3	-	0	-	4500	
17	in	558	21	-	15.6	-	3	-	0	-	4500	
18	in	556	17	-	16.3	-	6	-	0	-	-	
Sleeve in closed position, filter not attached												
0	in	-	22	-	15.6	-	3	-	0	-	-	CO2: 4.2%-6.0% Combustibles: 0%
2	in	730	-	-	14.3	-	0	-	0	-	-	
3	in	745	33	-	13	-	0	-	0	-	-	
5	in	-	28	-	14.2	-	0	-	0	-	-	
10	in	-	22	-	15.8	-	0	-	0	-	4000	
13	in	737	22	-	15.3	-	0	-	0	-	4000	
Sleeve in open position, filter attached												
0	in	255	0	-	21.2	-	6	-	0	-	-	CO2: 0.8% Combustibles: >2.5%
4	in	315	0	-	21	-	21	-	0	-	-	
5	in	361	11	-	9.1	-	>2000	-	0	-	-	SO2 reading is believed a result from oil combustion inside the black pipe. Higher oxygen reading resulted from air leaking under the gasket.
7	in	385	11	-	10.1	-	>2000	-	950	-	-	
15	1	124	-	0	-	14	-	>2000	-	-	-	
18	2	-	-	0	-	14.8	-	>2000	-	-	-	
20	3	-	-	5	-	11.6	-	>2000	-	414	-	
22	4	135	-	3	-	11.4	-	>2000	-	-	-	
24	5	-	-	0	-	13.3	-	>2000	-	-	-	
26	6	130	-	5	-	11.4	-	>2000	-	410	-	
28	7	143	-	6	-	10.5	-	>2000	-	-	-	
30	8	148	-	0	-	15	-	>2000	-	-	-	
33	9	137	-	6	-	15.1	-	>2000	-	-	-	
36	10	154	-	0	-	15.8	-	>2000	-	-	-	
38	11	145	-	6	-	11.5	-	>2000	-	-	-	
40	12	163	-	6	-	13.8	-	>2000	-	-	-	
42	in	437	9	-	13.6	-	>2000	-	-	-	-	
45	in	438	9	-	13.8	-	>2000	-	-	-	-	
46	in	438	8	-	14.2	-	>2000	-	307	-	-	
60	in	330	-	-	-	-	-	-	-	-	600	Burner was re-started.

*28% removal

APPENDIX A-2

1	2	3
4	5	6
7	8	9
10	11	12

in

Time	Location	Temp. (F)	NOx (ppm)		Oxygen (%)		CO (ppm)		SO2 (ppm)		Velocity (sfpm)	Notes
			In	Out	In	Out	In	Out	In	Out		
Sleeve in open position, filter not attached												
0	in	480	18	-	16.5	-	77	-	0	-	-	CO2: 3.3% (calculated)
5	in	480	20	-	16.1	-	11	-	0	-	-	
8	in	480	20	-	15.9	-	11	-	0	-	3800	
15	in	556	20	-	15.8	-	3	-	0	-	4500	
17	in	558	21	-	15.6	-	3	-	0	-	4500	
18	in	556	17	-	16.3	-	6	-	0	-	-	
Sleeve in closed position, filter not attached												
0	in	-	22	-	15.6	-	3	-	0	-	-	CO2: 4.2%-6.0% Combustibles: 0%
2	in	730	-	-	14.3	-	0	-	0	-	-	
3	in	745	33	-	13	-	0	-	0	-	-	
5	in	-	28	-	14.2	-	0	-	0	-	-	
10	in	-	22	-	15.8	-	0	-	0	-	4000	
13	in	737	22	-	15.3	-	0	-	0	-	4000	
Sleeve in open position, filter attached												
0	in	255	0	-	21.2	-	6	-	0	-	-	CO2: 0.8% Combustibles: >2.5%
4	in	315	0	-	21	-	21	-	0	-	-	
5	in	361	11	-	9.1	-	>2000	-	0	-	-	SO2 reading is believed a result from oil combustion inside the black pipe.
7	in	385	11	-	10.1	-	>2000	-	950	-	-	
15	1	124	-	0	-	14	-	>2000	-	-	-	
18	2	-	-	0	-	14.8	-	>2000	-	-	-	
20	3	-	-	5	-	11.6	-	>2000	-	414	-	
22	4	135	-	3	-	11.4	-	>2000	-	-	-	
24	5	-	-	0	-	13.3	-	>2000	-	-	-	
26	6	130	-	5	-	11.4	-	>2000	-	410	-	
28	7	143	-	6	-	10.5	-	>2000	-	-	-	
30	8	148	-	0	-	15	-	>2000	-	-	-	
33	9	137	-	6	-	15.1	-	>2000	-	-	-	Higher oxygen reading resulted from air leaking under the gasket.
36	10	154	-	0	-	15.8	-	>2000	-	-	-	
38	11	145	-	6	-	11.5	-	>2000	-	-	-	
40	12	163	-	6	-	13.8	-	>2000	-	-	-	
42	in	437	9	-	13.6	-	>2000	-	-	-	-	Burner was re-started.
45	in	438	9	-	13.8	-	>2000	-	-	-	-	
46	in	438	8	-	14.2	-	>2000	-	307	-	-	
60	in	330	-	-	-	-	-	-	-	600	-	

*28% removal (avg.)

APPENDIX A-3

MOBILE DIESEL GENERATOR
EXHAUST DATA - BASELINE

Source Mobile Diesel Generator
 Model MEP009B
 Serial No. KZO 0018
 Date 9/27/95

Raw data	Time (min)	Load %	Exhaust T1 (F)	Actual T2 (F)	Wet bulb T3 (F)	Hot Wire 1 (fpm)	Hot Wire 2 (fpm)	Pitot Tube (dP)	NO (ppm)	NO2 (ppm)	O2 (%)	CO (ppm)	Comb. (%)	SO2 (ppm)	Notes
	0	0	388	371	113	4400	4170	0.45	121	114	17.7	0	0	0	
	25	0	392	367	115	4100	4280	0.548	83	27	17.7	31	0	0	
	45	0	393	-	-	-	-	-	73	20	17.7	25	0	0	
	47	25	563	530	-	-	-	0.844	450	64	15	22	0	0	
	57	25	563	535	128	-	-	-	300	24	15.2	0	0.02	0	
	63	60	708	668	-	-	-	2.16	661	96	12.5	361	0.14	0	
	74	60	715	677	134	-	-	2.43	600	76	12.6	100	0.2	0	
	82	90	808	771	138	-	-	3.275	979	182	11.4	91	0.22	0	
	99	90	822	792	-	-	-	2.85	1213	193	10.6	160	0.47	0	

Calculations are based on the averages of two tests

Load KW	Exhaust T1 (F)	Actual T2 (F)	Wet bulb T3 (F)	Hot Wire 1 (fpm)	Hot Wire 2 (fpm)	Pitot Tube (dP)	Hot Wire 1 SCFM @32 F	Hot Wire 2 SCFM @32 F	Pitot Tube SCFM @32 F	Hot Wire 1 ACFM	Hot Wire 2 ACFM	Pitot Tube ACFM	Humidity	
													lbs H2O/ lb dry air	% Moisture
0	391.0	368.3	114.3	4250.0	4225.0	0.499	764.6	760.1	412.8	1287.2	1279.6	695.0	0.020	3.1
25	563.0	533.3	128.0	-	-	0.844	-	-	490.3	-	-	989.8	0.019	2.9
60	712.7	674.0	134.0	-	-	2.295	-	-	756.6	-	-	1743.9	0.018	2.8
90	817.3	785.0	138.0	-	-	3.063	-	-	834.2	-	-	2110.8	0.010	1.6

Calculations are based on the averages of two tests

Load RPM	NO (ppm)	NO2 (ppm)	O2 (%)	CO (ppm)	Comb. (%)	SO2 (ppm)	NO lbs/hr	NO2 lbs/hr	*NOx lbs/hr	CO lbs/hr	SO2 lbs/hr
0	92	54	17.7	19	0.00	0.0	0.19	0.023	0.214	9.16E-04	0.000
25	375	44	15.1	11	0.01	0.0	0.92	0.063	0.984	3.85E-04	0.000
60	631	86	12.6	231	0.17	0.0	2.39	0.181	2.571	5.87E-03	0.000
90	1096	188	11.0	126	0.35	0.0	4.58	0.624	5.206	2.55E-03	0.000

*NOx = NO + NO2

APPENDIX A-4

STATIONARY DIESEL-ENGINE
EXHAUST GAS DATA - BASELINE

Source Stationary Diesel Engine
Bldg. 262
Date 9/26/95

Raw data

Time (min)	Load KW	Exhaust T1 (F)	Actual T2 (F)	Wet bulb T3 (F)	Hot Wire 1 (fpm)	Hot Wire 2 (fpm)	Pitot Tube (dP)	NO (ppm)	NO2 (ppm)	O2 (%)	CO (ppm)	Comb. (%)	SO2 (ppm)
0	100	327.3	319.4	119	4000	3225	0.377	454	118	16.2	139	0	0
16	100	330	322	119	3600	3050	0.4	451	114	16.5	142	0	0
29	160	378	351	125	5000	3560	0.528	654	139	15.3	93	0	0
43	160	394	383	128	5300	3675	0.54	656	133	15.3	85	0	0
58	220	441	429	131	-	-	0.702	869	161	14.5	71	0	0
64	220	448	434	133	-	-	0.696	885	145	14.5	71	0	0
83	idle	297	284	105	-	2290	0.265	137	0	19	422	0	0
90	idle	265	257	105	-	-	-	-	-	-	-	-	-

Calculations are based on the averages of two tests

Load KW	Exhaust T1 (F)	Actual T2 (F)	Wet bulb T3 (F)	Hot Wire 1 (fpm)	Hot Wire 2 (fpm)	Pitot Tube (dP)	Hot Wire 1 SCFM @32 F	Hot Wire 2 SCFM @32 F	Pitot Tube SCFM @32 F	Hot Wire 1 ACFM	Hot Wire 2 ACFM	Pitot Tube ACFM	Humidity	
													lbs H2O/ lb dry air	% Moisture
100	329.1	321.1	119.0	3800.0	3137.5	0.389	1898.7	1567.7	1041.8	3014.6	2489.0	1654.1	0.038	5.7
160	388.7	372.3	127.0	5150.0	3617.5	0.534	2573.3	1807.6	1183.3	4353.3	3057.9	2001.8	0.047	7.0
220	445.7	432.3	132.3	-	-	0.699	-	-	1307.5	-	-	2371.4	0.050	7.4
idle	297.0	257.0	105.0	-	2290.0	0.265	-	1144.2	898.1	-	1667.5	1308.8	0.020	3.0

Calculations are based on the averages of two tests

Load RPM	NO (ppm)	NO2 (ppm)	O2 (%)	CO (ppm)	Comb. (%)	SO2 (ppm)	NO lbs/hr	NO2 lbs/hr	*NOx lbs/hr	CO lbs/hr	SO2 lbs/hr
100	453	116	16.4	141	0.0	0.0	2.37	0.254	2.622	6.79E-03	0.000
160	655	136	15.3	88	0.0	0.0	3.89	0.405	4.297	3.71E-03	0.000
220	877	153	14.5	71	0.0	0.0	5.76	0.569	6.327	2.66E-03	0.000
idle	137	0	19.0	422	0.0	0.0	0.62	0.000	0.618	2.57E-02	0.000

*NOx = NO + NO2

APPENDIX A-5

ADDITIONAL SCRUBBING TEST RESULTS

Solution	NO In (ppm)	NO2 In (ppm)	Ozone In (ppm)	NO In Impinger (ppm)	NO2 In Impinger (ppm)	NO Out (ppm)	NO2 Out (ppm)	Ozone Out* (ppm)	% NO2 Removed	% O3* Removed
0.01 M NaSH	2000	0	2000	400	1600	200	20	2	98.75	99.9
0.01 M Na2CO3	2000	0	2000	400	1600	400	100	50	93.75	97.5
0.01 M Ca(OH)2	2000	0	2000	400	1600	1300	120	75	92.5	96.3
Base	2000	0	2000	400	1600	400	1600	-	0	-

* Existence of NO2 causes interference in ozone measurements

APPENDIX A-6

BUS EXHAUST DATA - BASELINE

Source Bus - International
 Model S1700 (SS-22)
 Serial No. 85B 10522 (16982)
 Date 9/26/95

Raw data	Time (min)	Load RPM	Exhaust T1 (F)	Actual T2 (F)	Wet bulb T3 (F)	Hot Wire 1 (fpm)	Hot Wire 2 (fpm)	Pilot Tube (dP)	NO (ppm)	NO2 (ppm)	O2 (%)	CO (ppm)	Comb. (%)	SO2 (ppm)	Notes
	0	600	132.5	122.5	89	240	615	0.005	357	85	17.7	110	0	0	
	14	600	136.9	124.7	90	400	610	0.005	340	85	17.8	135	0	0	
	35	950	156.9	141.2	92	500	700	0.01	312	69	18	121	0	0	
	45	950	158	146.1	91	475	720	0.01	291	66	17.9	126	0	0	
	62	1450	192.5	186.6	100	800	1150	0.038	334	71	17.8	99	0	0	Re-zero Enersc
	72	1450	211.8	202	101	900	1190	0.035	373	72	18	92	0	0	
	84	2000	237.9	225	106	1575	-	0.085	327	74	17.9	130	0	0	
	97	2000	-	-	-	-	-	-	340	76	17.8	148	0	0	

Calculations are based on the averages of two tests

Load RPM	Exhaust T1 (F)	Actual T2 (F)	Wet bulb T3 (F)	Hot Wire 1 (fpm)	Hot Wire 2 (fpm)	Pilot Tube (dP)	Hot Wire 1			Hot Wire 2			Humidity		
							SCFM @32 F	lbs/hr	NO	SCFM @32 F	lbs/hr	NO	Pitot Tube ACFM	Hot Wire 1 ACFM	Hot Wire 2 ACFM
600	135.5	124.0	89.7	346.7	611.7	0.005	62.4	0.085	110.0	49.2	74.0	130.6	56.4	0.0222	3.4
950	157.6	144.5	91.3	483.3	713.3	0.010	86.9	0.102	126.3	68.4	106.8	157.7	84.0	0.0194	3.0
1450	205.4	196.9	100.7	866.7	1176.7	0.036	155.9	0.225	211.7	124.5	208.2	282.6	166.2	0.0194	3.0
2000	237.9	225.0	106.0	1575.0	-	0.085	283.3	0.316	-	187.4	394.5	-	260.8	0.0232	3.6

Calculations are based on the averages of two tests

Load RPM	NO (ppm)	NO2 (ppm)	O2 (%)	CO (ppm)	Comb. (%)	SO2 (ppm)	NO (lbs/hr)	NO2 (lbs/hr)	*NOx (lbs/hr)	CO (lbs/hr)	SO2 (lbs/hr)
600	346	85	17.8	127	0.0	0.0	0.085	0.190	0.276	8.87E-03	0.000
950	298	67	17.9	124	0.0	0.0	0.102	0.125	0.227	8.49E-03	0.000
1450	360	72	17.9	94	0.0	0.0	0.225	0.149	0.374	5.93E-03	0.000
2000	336	75	17.8	142	0.0	0.0	0.316	0.140	0.456	8.51E-03	0.000

*NOx = NO + NO2

APPENDIX A-7

INCINERATOR DATA - BASELINE

Temperature at Stack (F)	Gas Velocity (fpm)	Gas Flow Rate (acfm)	Gas Flow Rate (dscfm)	NO (ppm)	NO2 (ppm)	O2 (%)	CO (ppm)	SO2 (ppm)	Comb. (%)	CO2 (%)	Moisture Content (%)
140	2700	14900	10600	40	0	14.7	0	0	0	3.3	17.9

Source	Incinerator
Date	01/17/97
Duct	32"
Location	Ft. Dix
Load	Normal Operating Conditions