

JPRS-UCC-90-004
9 MAY 1990

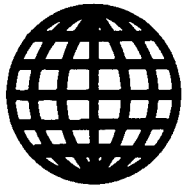

**FOREIGN
BROADCAST
INFORMATION
SERVICE**

JPRS Report

Science & Technology

USSR: Computers

Reproduced From
Best Available Copy

DISTRIBUTION STATEMENT A

Approved for public release;
Distribution Unlimited

REPRODUCED BY
U.S. DEPARTMENT OF COMMERCE
NATIONAL TECHNICAL INFORMATION SERVICE
SPRINGFIELD, VA. 22161

19981217 117

DTIC QUALITY INSPECTED 3

Science & Technology

USSR: Computers

JPRS-UCC-90-004

CONTENTS

09 MAY 1990

GENERAL

Parallel Programmable Computer Systems in Telecommunications [I.A. Mamzelev, K.G. Kniazev; PROCEEDINGS OF THE FIRST INTERNATIONAL COMPUTERS AND COMMUNICATIONS CONFERENCE, 25-26 Oct 89]	1
VME-bus, FASTBUS Systems, Modules at Laboratory of High Energies [I. F. Kolpakov; SIXTH SYMPOSIUM ON MICROCOMPUTER AND MICROPROCESSOR APPLICATIONS, 1989]	2
IBM PC/XT Serial, Parallel Interfaces for Experimental Equipment Connection [A. P. Pavlov, V. T. Sidorov; SIXTH SYMPOSIUM ON MICROCOMPUTER AND MICROPROCESSOR APPLICATIONS, 1989]	5
Highly Parallel Architecture for New Generation PPC [M. B. Ignatiev, Y. E. Sheinin; SIXTH SYMPOSIUM ON MICROCOMPUTER AND MICROPROCESSOR APPLICATIONS, 1989]	6
Dual Microprocessor-based Load-sharing Microcomputers [V. K. Koblyakov, S.V. Suvorov; SIXTH SYMPOSIUM ON MICROCOMPUTER AND MICROPROCESSOR APPLICATIONS, 1989]	8
High Speed Cluster LAN for Professional Personal Computers [S. W. Gorbachev, Y. E. Sheinin; SIXTH SYMPOSIUM ON MICROCOMPUTER AND MICROPROCESSOR APPLICATIONS, 1989]	11
Microprocessor Shortage Hampers Personal-Computer Production [F. Vladov; NTR: PROBLEMY I RESHENIYA, 1989]	13

HARDWARE

Twenty Years of Cooperation of Socialist Countries in the Field of Computer Technology [NOVOYE V ZHIZNI, NAUKE, TEKHNIKE: VYCHISLITELNAYATEKHNIKA I EYE PRIMENENIYE, No 11, Nov 89]	14
--	----

SOFTWARE

Self Tuning Software Interface Orchestrating Microcomputer, Elektronika 8201 FODCS Interaction [G. A. Aleksanyan, et al; IZVESTIYA NAUK ARMYANSKOY SSR; SERIYA TEKHNICHESKIKH NAUK, July-August 11989]	30
---	----

APPLICATIONS

Problems of Machine Translation [NOVOYE V ZHIZNI, NAUKE, TEKHNIKE: VYCHISLITELNAYA TEKHNIKA I EYE PRIMENENIYE, 1 Jul 89]	32
---	----

Parallel Programmable Computer Systems in Telecommunications

18630007 Budapest PROCEEDINGS OF THE FIRST INTERNATIONAL COMPUTERS AND COMMUNICATIONS CONFERENCE in English 25-26 Oct 89 pp 191-198

[Article by I.A. Mamzelev and K.G. Kniazev, Moscow Institute of Telecommunication, USSR]

[Text] Abstract:

The control computer association (CCA)—a multicomputer microprocessor-based homogeneous computer system with a variable structure—is presented as an efficient control and computation means for new generation telecommunications systems.

The majority of telecommunications tasks are shown to be effectively decomposable into subtasks on the basis of large-scale (large-grained) decomposition methodology. The tasks of information switching are considered as typical examples.

The main way of improving the means and systems of telecommunications is the intensive use of digital computer systems in designing and constructing new generation communications systems, telecommunications management and control systems for the existing networks. The wide use of microprocessors and parallel processing is of special interest as an efficient and cost-effective way of increasing system modularity, availability and computer power. However, the use of these potential advantages strongly depends on our ability to decompose the application task. Our analysis shows, that the majority of telecommunications control, maintenance, management and administration tasks can be effectively decomposed into parallel subtasks on the basis of the structured large-scale decomposition methodology developed and investigated in.¹ As a typical example we consider the task of information switching in a switching center. In effect, the task of information switching in a circuit switching center is to establish the one-to-one correspondence between different pairs on the set of nodes associated with subscriber circuits and trunks. The structured large-scale decomposition methodology (SLDM) makes it possible to provide two main kinds of parallelism in this task: functional and data parallelism. Data parallelism is determined by the possibility of concurrent path establishment between a variety of circuits. Functional parallelism can be provided due to the possibility of concurrent execution of the set of typical functions during the path establishment between different pairs of circuits. We show that different ways of decomposition of the subscriber matrix and the set of function matrixes by parallel planes allow us to obtain all the well-known operation modes of control computers: load sharing and resource sharing, different kinds of backuping. A similar analysis was carried out for the combined switching centers, realising both packet and circuit switching. The method of combined switching is shown to be very promising due to the

relatively high load of expensive communications channels. According to the open systems interconnection basic reference model the technological functions of the combined switching center can be presented in the form of the three-layered hierarchical functional structure including physical, data link and network layers. Functional elements of the physical layer are linked with different communications channels and thus can operate in parallel. Main functional elements of the data link layer algorithm: data reception, accumulation, frame error correction, frame coding, are data and control independent for each element of physical layer and thus can also be executed in parallel. We also show, that the main functions of the network layer: reception of signal, service and information frames, establishing and discarding of virtual channels, routing of information frames, actualisation of routing matrixes in the case of adaptive routing and dynamic flow control in the packet switching mode, also can be carried out concurrently for different frames. Due to the possibility of the effective decomposition of the algorithms on the basis of SLDM the control computer of a switching center on the principles of the control computer association model.² The generalised structure of the control computer association (CCA) is presented in Figure 1.

The central element of the CCA is the computing module CM, which presents an algorithmically closed system able to realise each sequential algorithm (i.e., von Neiman computer model). All the CM's are interconnected in the computer association by the means of system interface modules SI and the communications network 1 of regular structure (mesh, ring...). The system consisting of the CM and the appropriate SI is called an elementary computing module ECM. The elements of the controlled and managed communications equipment—communications channels, switches, local controllers—are connected with ECM's by the means of communication interface modules CI and communications network 2 in the way, which provides each ECM the possibility of controlling a set of elements of equipment and each element of equipment the possibility of being controlled by a set of ECM's. The most difficult application tasks, such as optimisation, can be carried out by a group of ECM's coordinating their activities and working in parallel. The control computer association realises three main principles: concurrent operation of system elements, variable and programmable interconnection structure, modularity (homogeneity) applied both to the means of computation and the means of interfacing between ECM's and controlled equipment—which further develops the well-known ideas and principles of computer associations.¹ The operation of the control computer association can be presented as the sequence of the following phrases: internal programming of communications networks 1 and 2 in order to create the desirable communications structures, gathering of data concerning the controlled equipment, information exchange between ECM's, autonomous operation of ECM's, exchange of control and coordination data

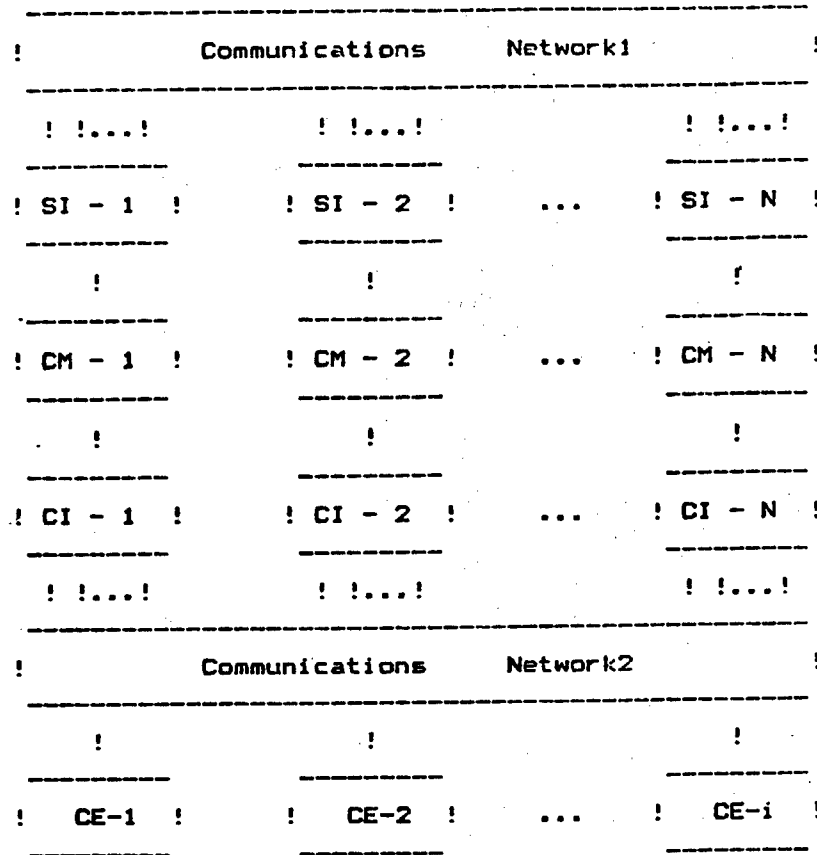

Fig. 1. The Generalized Structure of the CCA

between ECM's and CE's. The control computer association can be effectively realised as a microprocessor based homogenous multicomputer structure which makes it cost effective in a wide variety of characteristics.

References

1. E.V. Evreinov. Homogeneous Computer Systems and Structures, Moscow, 1981.
2. I. A. Mamzelev. Computer Systems in Telecommunications. Moscow, 1987.

VME-bus, FASTBUS Systems, Modules at Laboratory of High Energies

28630006A Budapest SIXTH SYMPOSIUM ON MICROCOMPUTER AND MICROPROCESSOR APPLICATIONS in English 1989 pp 323-329

[Article by I. F. Kolpakov, Joint Institute for Nuclear Research, Dubna, USSR]

[Text] The hardware of modern elementary particle spectrometers and accelerator control systems are based on the 32-bit VME and FASTBUS standards.

The VME-bus (IEC.821 standard) allows one to introduce computer power equivalent to present-day supercomputer into the hardware of an experiment. The control system for a cycle generator of the superconducting synchrotron as well as a set of modules developed in the VME standard are considered.

FASTBUS is de facto an international standard for modern multichannel detector hardware. It provides the highest speed at a minimal registration channel cost. An analog information registration system of the SFERA spectrometer and a set of developed FASTBUS modules are described.

Introduction

VME and FASTBUS 32-bit buses have found wide use in the hardware of modern elementary particle physics spectrometers and accelerator control systems.

A FASTBUS bus is used extensively in the hardware of multichannel particle detectors of superhigh energy physics spectrometers. It provides the highest speed to cost ratio for registration channels.

A VME bus (IEC.821) represents an international standard and allows one to introduce computer powers,

which are equivalent to present-day supercomputers, directly into experimental hardware.

FASTBUS¹—and VME²—based systems and a set of modules have been developed at the Laboratory of High Energies.

FASTBUS System for Analog Signal Acquisition

The architecture of a FASTBUS system makes it possible to build practically any superlarge system in a modular way.

At the Laboratory of High Energies a number of modern experimental installations are being constructed. They are designed for high energy physics research based on a wide use of the FASTBUS standard. Early developments in this standard in the SFERA³ spectrometer are applied for studying multiple cumulative particle production in the geometry close to 4π . Due to a low yield of the considered processes, the spectrometer has to process high intensity particle beams ($10^9 + 10^{11}$ particle/s) what requires high-speed registration channels. The presence of thousands of information channels of a different type stimulates a search for new ways in the development of data acquisition electronics. The use of FASTBUS for solving the problems of fast data acquisition and selection has a lot of advantages over other existing standards. The system for recording analog signals of the SFERA spectrometer in the FASTBUS standard has been developed (see Fig. 1). [not reproduced] Fast analog signals are transformed into a digital form by means of a FASTBUS 16-channel 8-bit ADC. The ADC conversion time is 40 ns. Information is read out from ADCs by a FIORI I/O register simultaneously from two channels. This module realizes a control protocol and transmits data to a bus for a FASTBUS segment. It also accomplishes a liaison with a computer. FIORI control commands and data are transferred through two 16-bit bidirectional I/O registers made as CAMAC modules. In the present scheme of liaison between FASTBUS and CAMAC buses the exchange process is controlled by an Elektronika-60 microcomputer. It is connected to the CAMAC crate containing I/O register modules by means of a branch driver and a crate controller of the A type. The minimum access time to the FASTBUS segment obtained in the system is 60 mcs. This is due to a rather low speed of the microcomputer and the FIORI module which requires a certain number of CAMAC cycles per one command. The total time of data processing is $1 + 3$ ms which is in good agreement with time characteristics of similar systems.

The software of the system has a two-level structure which allows one to separate the tasks of information acquisition, current control, data processing and presentation at a higher level of data recording and control the program works as a task of the RT-11 operative system. It performs the following operations: module initialization, ADC coupling to the computer according to the FASTBUS protocol, data testing and preparation for

subsequent handling which is realized by a background program. The set of MULTI-FB histogram programs has been used.

FASTBUS Modules

A crate and FASTBUS modules have been and are being developed for the system under consideration and for the spectrometers prepared for UNK experiments. Among these are:

- a 16-channel 8-bit ADC with a 40 ns conversion time;
- a fast 8-channel ADC with an 8-bit 256-word memory;
- a 16-channel 350 Mc/s TDC;
- a 32x32-bit two-port buffer memory;
- a 32-bit parallel input shift register (8 words deep);
- a bus display module.

A number of auxiliary devices, including ventilation panel and crate mechanics, has also been developed.

VME-bus-Based Control System

A VME bus is widely used in advanced physics research as a base for designing data acquisition and data processing systems of elementary particle spectrometers, e.g., UA1 at CERN, as well as control systems of modern and future accelerators, for example, LEP/SPS.

In the last few years a microcomputer-based subsystem of accelerator cycle control has been in use in the control system of the superconducting synchrotron SPIN. The main tasks of the system are to control the bending magnets and lenses of the synchrotron ring and to synchronize accelerator elements and power supply current testing.

The system makes it possible to carry out studies at the synchrotron in two regimes: warm and helium-cooled.

Availability of just one computer in the system makes it impossible to correct the parameters of an accelerator cycle in real time. The generation of accelerator cycles was interrupted and a number of cycles was lost during an operative personnel dialogue and the subsequent calculation of power supply control code tables. The dead time of the system, T_m , was dependent on the time of operative personnel reaction and numerical values of introduced parameters. The use of a real-time system of the TR11-FB type did not solve the problem due to a low speed of the processor.

The goals of the system have been realized using a multi-processor system liaisoned via a VME bus.

A new version of the accelerator cycle control system is shown in Fig. 2. [not reproduced] Dialogue parameter setting-up and table calculations are performed by a Pravetz-16 PC. Both program sources of the system are coupled via a VME buffer memory module. The memory stores calculated results from the PC. These data are read out from the VME buffer memory within the space

between accelerator cycles to the memory of the MERA-60 microcomputer. This makes it possible to start a new accelerator cycle with desirable parameters of power supply cycle pulses.

The system software consists of two subroutines written in FORTRAN providing a dialogue and table calculations. The program requires 64 Kbytes of RAM and runs under the control of DOS-16.

The dead time in the new system is smaller by a factor of 300 and any change of parameters just prolongs an interval between accelerator cycles up to an acceptable value.

VME Modules

For the system under consideration and others a set of VME modules has been and is being developed. Among these modules are:

- S.01—a system controller with a synchrosignal generator, an arbitrator and a termination unit;
- P.01—a four-channel serial register with an input organized according to the RS-232C protocol. It contains an Intel 8085 processor node with 32 k RAM and 16 k PROM;
- Z.01—a 0.5 MB two-port DRAM accessible from a bus and a front panel;
- I.01—a 16-bit parallel register;
- I.02—a Q-bus system channel interface;
- I.03—a V-bus adapter;
- I.04—a DMA PC Pravez-16 interface;
- I.06—a CAMAC branch driver.

VME-bus in Data Analysis and Processing

In traditional computers data are processed sequentially step by step. Physics and technological restrictions do not allow one in the near future to exceed significantly a value of 10 Mflops over S and, consequently, limit the calculation speed.

A modular supercomputer based on multiple parallel 32-bit processors with a speed of 1 Mflops over 3 is suggested. The processors are assembled to one supercomputer community by means of standard VME crates. The calculation process is supervised by a microVAX-11 host computer. Data I/O is implemented via host computer peripheral devices. The software of the system is based on FORTRAN-77. The supercomputer can be integrated with the present JINR LAN through one of its ports to provide access to all users. The supercomputer allows one to calculate the most cumbersome tasks of elementary particle and accelerator physics, in particular Monte-Carlo and accelerator simulation.

The only limitation for solving the tasks is the possibility of their separation into parallel similar fragments.

Events in spectrometers are statistically independent. This situation allows one to handle them in a parallel

way in a number of similar processors. In the supercomputer event data are distributed over numerous processors by a commutator. Each processor works with a similar handling program package. A relatively small volume of transferred data in comparison with the required calculation time allows one to involve hundreds of parallel processors in the handling process thus amplifying the power of the system almost in proportion to the number of used processors.

The architecture of the modular supercomputer consists of three main parts (see Fig. 3) [not reproduced]: a microVAX-11 host computer and its peripheral devices, a set of modular processors and LAN coupling means.

The host computer prepares calculation tasks for the modular processors, organizes the process of experimental data readout from magtape units or from the local network, distributes this information over the modular processors, accumulates and summarizes the results of data analysis obtained in the set of processors. The present architecture of the supercomputer is based on 72 modular processors distributed over four VME crates coupled to a control VME crate via star connection.

Each VME crate comprises up to 18 processors. The scheme shown above represents the first stage of the project.

The basic processor module of the supercomputer is composed of a 32-bit Motorola MC 68020 processor, a floating point coprocessor of the MC 68881 type, a RAM control chip of the MC 68851 type, an 8 Mb RAM, and a VME bus interface. Among the main software components are intercommunication programs, technological programs, e.g., a FORTRAN-77 compiler, and libraries of the applied programs (CERNLIB, HBOOK, ZBOOK, HPLLOT, GEANT and so on). The software under development is a supercomputer communication routine.

The microVAX-11 system software is based on traditional means (VMS or UNIX) and routine software development tools.

The processor module system is a usual TMS monitor which provides a certain set of functions such as data interchange with the host computer, program errors and debugging.

Conclusion

The use of 32-bit VME and FASTBUS buses allows one, in principle, to solve the tasks of data acquisition and most problems of data analysis in the field of elementary particle physics.

The development of VME-FASTBUS modules and systems seems to be attractive for use in applied and other fields of human activities.

References

1. N. P. Basyleva, et al., VME bus and a Pravetz-16 PC in the Cycle Control Subsystem of the Superconducting Synchrotron, JINR Rapid Communications 6 (26) (Dubna, 1987) pp 12-14.
2. S. V. Afanasiev et al., FASTBUS System for Measurements of Analogue Signals for the SPHERA Spectrometer, JINR Rapid Communications 1 (27) (Dubna, 1988) pp 8-11.
3. I. F. Kolpakov et al., JINR Supercomputer of the Modular Type for Event Parallel Analysis, JINR Rapid Communications 2 (22) (Dubna, 1987) pp 35-39.

IBM PC/XT Serial, Parallel Interfaces for Experimental Equipment Connection
18630006B Budapest SIXTH SYMPOSIUM ON MICROCOMPUTER AND MICROPROCESSOR APPLICATIONS in English 1989 pp 331-334

[Article by A. P. Pavlov and V. T. Sidorov, Joint Institute for Nuclear Research, Dubna, USSR]

[Text] The wide circulation of the IBM PC/XT personal computer, which has a relatively low cost combined with its unlimited number of software products make it very attractive for automation of physical experiments. At the same time the standard configuration includes only the serial RS-232C and parallel CENTRONICS byte interfaces only. This is not enough to effectively connect the necessary experimental equipment to the PC. To solve this problem two interface cards were developed at the Laboratory of Nuclear Problems, JINR.

Serial Interface Card

The electronics used in experimental nuclear physics is mainly in the CAMAC standard. This is why the PC interface was designed keeping in mind the existing equipment, which it must provide connection to.

Fast serial CAMAC-CAMAC link modules are widespread in our Institute, so the IBM PC/XT serial interface card with the same data transmission protocol and electrical parameters compatible with the existing CAMAC modules was developed.

This card consists of two identical channels each based on a 20-bit shift register. Parallel data are written to and read from the computer. Serial data are transmitted through the rear panel sockets. Serial input and output data transmission is provided via two coaxial connectors (one is for input and one for output) for link by means of coaxial cables, via the multipin connector for two twisted pairs (one pair is for input and one for output).

Data transmitting signals have the TTL levels in the coaxial cables. For the twisted pair connection the 75107 and 75110 driver and receiver are used.

The data transfer rate is 1.25 Mbits per second, i.e., it takes 16 microseconds to transmit/receive a 16-bit word. Clock pulses have the frequency of 10 MHz.

A transmitted word consists of 1 "Start" bit, 16 data bits, a "Flag"-bit and 2 "Stop" bits. The level of the "Start" bit corresponds to logical "1." The data bits are transmitted sequentially with the least significant bit first. The "Flag" bit can be used as parity bit, as "End of Message" sign, etc.

Each interface card channel is addressable by the computer processor as a two-byte word of the memory. One serial interface card occupies 16 bytes of the memory space. A base (segment) address may have a value of C000(hex) or greater and is chosen by jumpers on the card's printed board. The status byte, which can be read, defines the current status of the channels: receiver ready, transmitter ready, state of the "Flag" bits.

Word transmission to the line begins after the bus command of high byte writing. A channel is ready for reading when the "Receiver ready" bit of the status register is set. The special read command allow to initiate the transmission of the received data word back to the line.

The interface card can send the interrupt signal to the processor when one of receivers is ready. This feature is enabled by the jumper setting.

Serial Interface Technical Parameters

Number of Channels	- 2
Data transmitting/receiving format:	
Start	- 1 bit
Data	- 16 bits
Flag	- 1 bit
Stop	- 2 bits
Transmitting rate	- 1.25 Mbits/s (16 us/word)
Distance:	
Twisted pairs	- 1 km
Coaxial cables	- 100 m

Serial Interface Addresses Summary

Address	READ Command	WRITE Command
Base: 0	Word from Ch0	Word and Flag=0 to Ch0
Base: 2	Word from Ch1	Word and Flag=0 to Ch1
Base: 4	Word from Ch0 and send it back	Word and Flag=1 to Ch0
Base: 6	Word from Ch1 and send it back	Word and Flag=1 to Ch1
Base: 8	Status Byte	

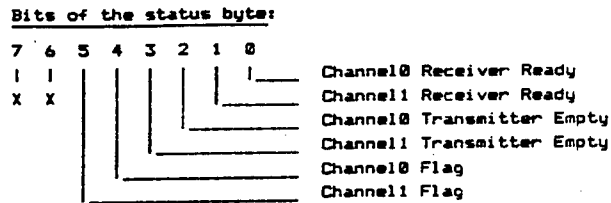

Parallel Interface Card

This card includes the input and output 16-bit registers, which are read and written through the computer bus.

Data to the input register are entered via a 23-pin connector and strobed to the register by the external strobe signal. It sets the "Input register ready" flip-flop as well.

The input register accepts 16-bit data with the TTL levels, stores and transfers data to the PC bus in response to the read command. The transfer to the register is initiated by a strobe signal from an external source. The input register has also the "Gate" mode. In this case no strobe pulse is needed to transfer data to the register.

The computer read command forms a response signal to the connected equipment in the form of pulse and level. The "Input register ready" flip-flop is cleared at this moment. The external "End of Message" signal sets the appropriate flip-flop.

The output register is set by the write command from the PC bus and transfers 16-bit data to the 23-pin connector. The outputs are capable of sinking 40 mA to earth or withstanding +30V with respect to earth. A request signal is sent to the connected equipment in response to the write command. It has the form of pulse and level. The "Output register ready" flip-flop is cleared at the same time. The external equipment must produce the response signal when it is ready to receive new data. This signal sets the "Output register ready" flip-flop.

A controlled multiplexer can form the interrupt signal to the PC bus. Outputs of the "Input register ready," "Output register ready" and "End of Message" flip-flops are the inputs for this multiplexer.

There is a 4-bit control register in the interface card. One bit defines the "Gate" or strobed mode of the input register, three other bits enable or disable passing the above signals to the interrupt line of the PC bus.

The status register allows the state of the control register and "Output register ready," "Input register ready," "End of Message" flip-flops to be read.

The interface card registers are addressed like the computer memory. The base address is adjusted by jumpers on the card.

Highly Parallel Architecture for New Generation PPC

18630006C Budapest SIXTH SYMPOSIUM ON MICROCOMPUTER AND MICROPROCESSOR APPLICATIONS in English 1989 pp 467-474

[Article by M. B. Ignatiev and Y. E. Sheinin, Leningrad Institute of Aviation Instrument Making USSR, 190000, Leningrad, Herzena St. 67, LIAP]

[Text] Highly parallel architecture for personal supercomputers—PPC of a new class—is proposed. It is based on the recursive machines concept. The paper describes Recursive Personal Computer (RPC) multi-level virtual organization for VLSI implementation on microprocessors and ASIC. Prototype multimicroprocessor System 3M is presented.

The advance in design automation, integrated CAD in various fields, including VLSI and ULSI design require an ever-increasing computer performance, tend to bring high computer power nearer to a designer's work place up to giving him such computers at his own constant and personal disposal. This is one of perspective application fields for personal supercomputers (PSC)—computing systems of a new class. For such PSC the high computer power in conjunction with the economical efficiency, the simplicity and the reliability in operation can be obtained only with VLSI high parallel computers. Recursive computer concept [RC] is a prospective concept for high parallel computers design.¹

The recursive personal supercomputer [RPS] internal organization can be described as a multilevel system of virtual machines.² Three basic levels can be distinguished: architecture level, logical structure level and hardware structure level. [Table 1]

Table 1. Multilevel Virtual Organization of RPS

Characteristic features of a level	Levels		
	Architecture level	Logical structure level	Hardware structure level
Recursiveness	Internal language recursiveness	System organization recursiveness	Topological recursiveness of structure
Program functioning environment in level machine language	Computational entity	Interacting modules system	Set of independently programmable modules
Memory	Shared	Distributed over modules	Distributed over modules
Processor and processes	Single process in [virtual] processor	Set of processes in a module	Set of processes in a module
Resources limited	Unlimited resources	Finite resources	Quantitatively fixed resources
Switching functions in the system	No	Restructured logical channels between processes	Fixed hardware links between modules

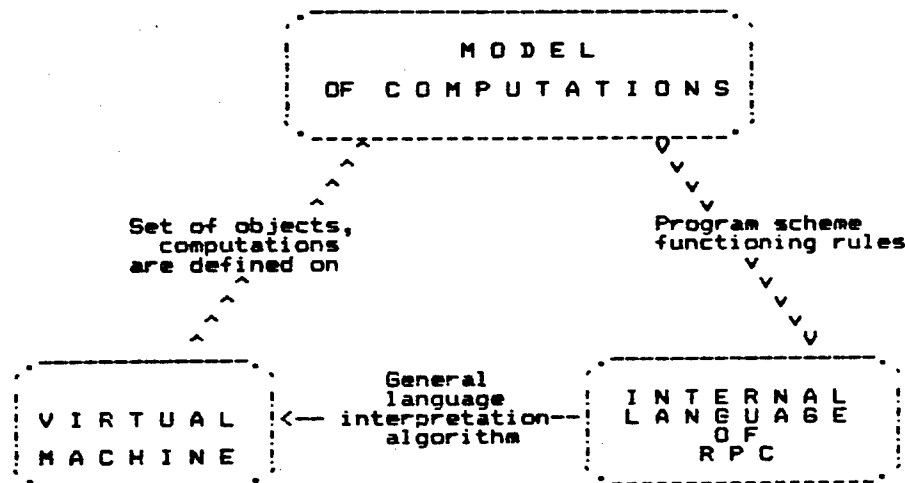

Figure 1

Architecture level is first of all, determined by the features of the RPS internal machine language, Fig. 1. The RPS internal machine language recursiveness is a language recursiveness of this level language. A program in RPS internal machine language can be represented as a recursive structured object containing both operators and data.

A program in internal machine language operates in a computing entity of unlimited resources. Each active program element is matched with its own machine component which is not shared by other active program elements [a virtual processor is matched with an operator, a data-object is matched with a cell of a mathematical memory unit]. The dynamics of a program operation and a delete of program objects during the computational process are directly revealed in the dynamics of a virtual machine structure. Virtual machine components directly interact with each other, there are no switching functions at the architecture level, Fig. 2.

The logical structure level comprises features of RPS system organization. A virtual machine of this level is represented by a finite set of modules which interact by means of a switching system, Fig. 3. A module is a general-purpose component which is determined recursively within the logical structure. A module builtin facilities implement complete set of basic functions, such as data processing, computation control, data storage, in-system PSC is heterogeneous, so it can consist of various type modules. Each module implements a finite set of processes. At the logical structure level a switching system is an integral object, which implements a process-process inter-module interaction. This switching system operates in reply to explicit requests sent by the processes being executed in the modules.

The memory is distributed over the modules, where it is represented by a dynamically changing set of variable length linear segments. The processes operating in the module have a direct access to another module memory through interim-processes which are available in such

module. Both an individual module resources and system resources as a whole are finite. The resources limitations are not quantitative but they are qualitative by nature. They appear as a failure possibility for process resource request.

Hardware structure level represents a system as a set of hardware blocks interconnected by fixed links. The topology of this structure corresponds to some recursive determination. At the hardware structure level the RPS internal machine language is a set of module machine languages. A program in each module operates separately. The RC multiprocessor organisation is transparent from within a hardware module since existence or absence of any other modules is not represented in the module machine language semantics.

A recursive PSC module complexity [except its RAM] corresponds to a modern 32-bit microprocessor VLSI complexity. the RC heterogeneity enables to complement the modules by various types VLSI coprocessor. The paper gives a formal description of all the above-mentioned levels.

The RPC can be programmed using the expanded versions of conventional programming languages, which support a modular program organization and a separate module compilation.

The language extensions are represented by built-in functions [for system environment calls from program modules] and by superlanguage Az which enables to specify a program as an asynchronous dynamic network of program modules processes.

The 3M multimicroprocessor system prototype of a recursive PSC, was built on bit-slice and single chip microprocessor LSI, Fig. 4.³

[References omitted]

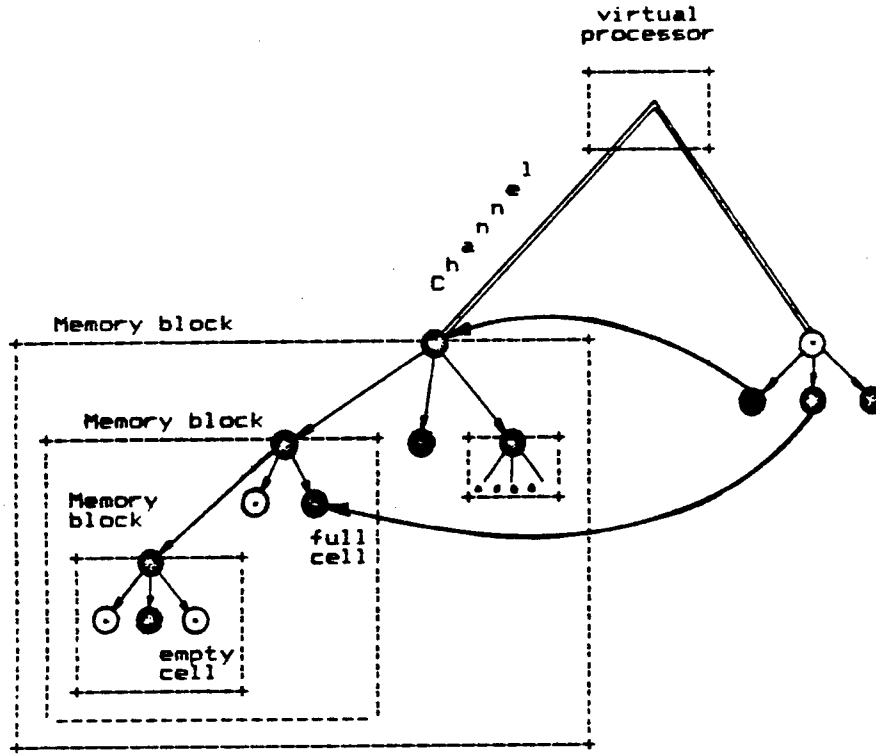

Figure 2

Dual Microprocessor-based Load-sharing Microcomputers

18630006D Budapest SIXTH SYMPOSIUM ON MICROCOMPUTER AND MICROPROCESSOR APPLICATIONS in English 1989 pp 475-479

[Article by V. K. Koblyakov and S. V. Suvorov, Special Construction Technological Department "Mercury" 450022 Ufa-22, Mendeleev St. 134, USSR]

[Text] Great increase of requirements to the communications systems involved the necessity for considerable complication of the software used and thus the necessity to increase control computer capability. There are known systems using multiprocessor control unit technique. E.g., X system of Plessey (UK). The multiprocessor system architecture is based on the multiplexer concept with the loading shared processors controlled by the operating system.

Mass production of LSI microprocessor sets with large functional capacities, their low cost, flexibility and accuracy of digital data processing methods made these microcomputers (MC) system elements, providing the base for production automation, communication and measuring systems, etc....

For the last 20 years computer aids found an especially large application in communication engineering. With the stored program control, various computer-based

communication systems enable the users to have still increasing number of services and fully automated process to use both the equipment itself and subscriber lines and terminals. Communication systems use both one-chip microcomputer Intel 8080, 8038, 8045, 8086 (Soviet series 580, 1810, 1816), Motorola 6800 and multi-chip (sectioned) microcomputer-aided microprocessors, e.g., Series AMd 2900 (Soviet 1804).

Great increase of requirements to the communications systems involved the necessity for considerable complication of the software used and thus the necessity to increase control computer capability.

There are known systems using multiprocessor control unit technique. E.g., X system of Plessey (UK).

The multiprocessor system architecture is based on the multiplexer concept with the loading shared processors controlled by the operating system.

Alongside with the task to increase the capability of control units in communication systems it is necessary to solve the task to improve their reliability (standard requirements—less than 2 hours delay for 40-year operation).

There are also systems using different methods of processor duplication with the purpose of increasing control units reliability:

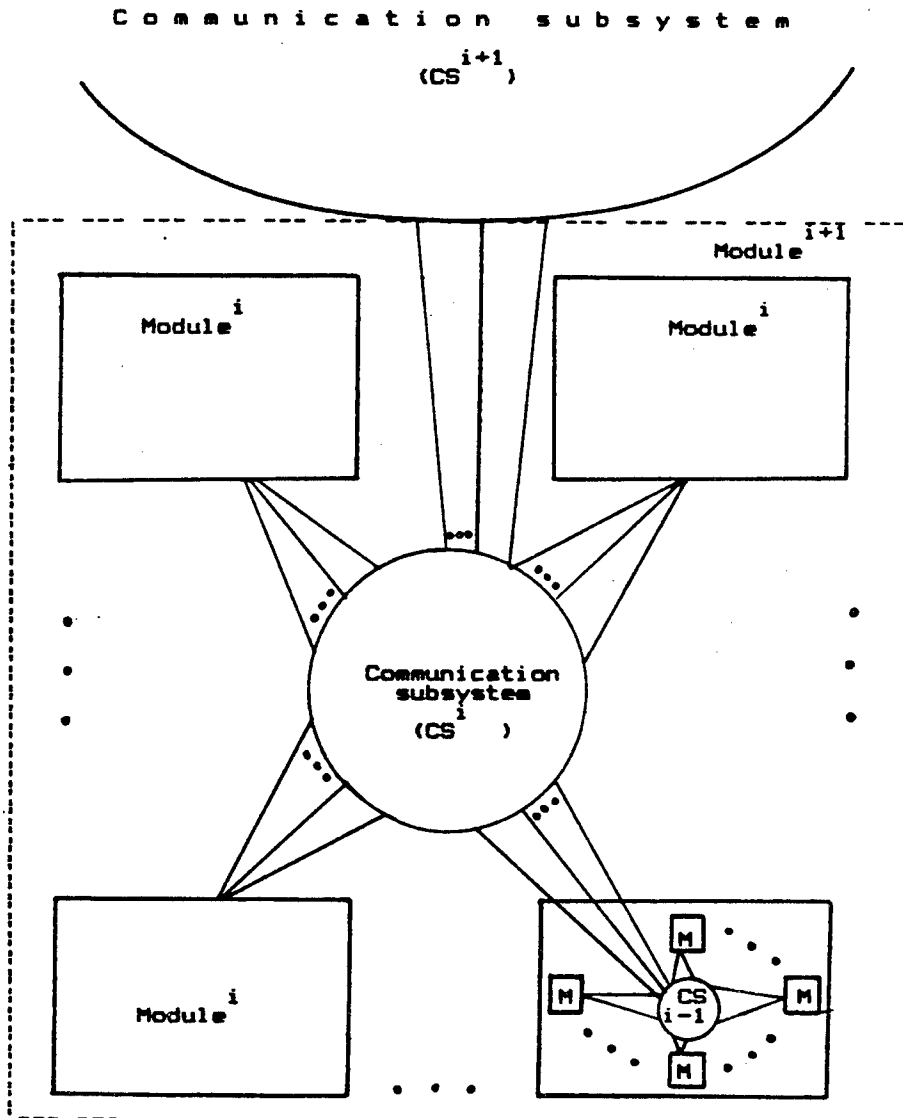

Figure 3

1. "Hot reserve"—when 2 computers handle the same problems and compare results. On error detection the faulty computer is disconnected. This method is used in ESS exchanges (USA) and KWANT exchanges (USSR).

2. Dynamic function separation—when tasks are handled under the common monitor control. The 1st computer begins the handling and the 2nd ends it. On monitor request the response is given by the free computer. It is used in private exchanges, such as developed by Thomson.

3. "Static function separation"—when each computer is responsible for executing its own functions. During the task handling process there is a continuous data exchange.

4. "Loading-sharing"—when 2 computers share the tasks as they are delivered on the principle of randomness. During the operation the computers keep exchanging status data. If one computer breaks down all the loading may be handled by the other.

Our enterprise in cooperation with AISATEL (France) developed and realised for manufacturing dual microprocessor-based load-sharing modular microcomputers series 2901 and 2904.

Basic specifications:

- digit capacity—32/32—bit data bus, 16-bit address bus;

System 3M

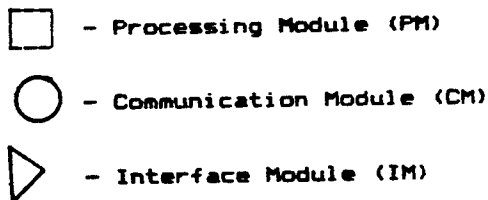
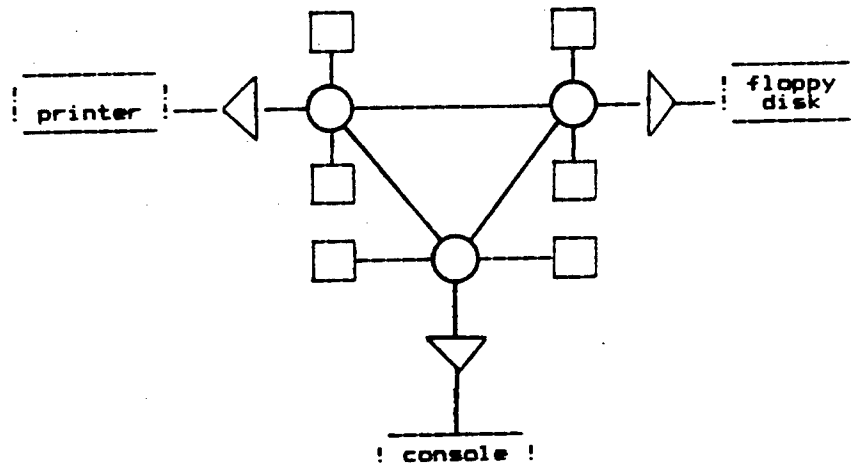

Figure 4

- microcommand execution time in 244ns (execution time for commands depends on the number of microcommands, realising the given command and memory access time;
- realization of 48 Assembler USE-11 commands;
- 1 level and 32 sublevels of interruption;
- load-sharing operation: if one computer fails all the tasks are handled by the other with automatic error localization;
- reliability: downtime probability is less than $0.5 \cdot 10^{-5}$ for the period of 140 years;
- amount of equipment: 10 PCB, 234 x 365 x 27 mm and 2 power supplies.

The PCB_s assignment:

- ALN—2
- Microprogram control unit—2
- Intercomputer communication unit—2
- Program memory—4
- Supply voltage—+ 5 V power used—up to 100 W
- Periphery:
 - teletype,
 - display,
 - optionally, cartridge tape drive.

General application: it is used as the EAX subscriber concentrator control unit. Also it may be used as control unit for other radio electronic systems requiring large capability and reliable functioning control units. The architecture of each microcomputer is standard as recommended by AMD.

The intercomputer communication unit (LIC) is of greatest interest. It consists of the microcomputer start-stop system and provides data exchange between 2 microcomputers and between each microcomputer and non-duplicated periphery. The data exchange involves execution of the following functions, realised by the proper equipment modules and software.

- “Intermicrocomputer communication” : two-direction 64-bit register, holding data on two microcomputer exchange.
- “Computer status word”—16-bit register, holding data on two microcomputer status (working, disabled, testing, etc.). One bit change in the 1st microcomputer status word generates the 2nd microcomputer interruption signal.
- “Exclusion”—enables to settle data source access conflict between two microcomputers.

- “Interruption pulse generator”—interruption of 2 microcomputers every 4 ms with the shift of 2 ms.
- “Two microcomputer control”—enables alternate switching of 2 microcomputers in case of simultaneous accidental stop.
- “Time delay latch”—checks the control over microcomputer and periphery exchange.
- “Timing-pulse generator”—excludes the influence of one microcomputer on the other.

Task handling is associated with the necessity for inter-computer message exchange. All these messages have the format of 4 16-bit words. The last word is the check word. Data exchange process goes in the following sequence:

For example, microcomputer A initiates interchange and simultaneously writes data into its LIC for transmission; and on completion of writing it creates interruption LIC 1 in microcomputer B.

Microcomputer B carries out reading and then creates interruption LIC 0 in microcomputer A, cancelling interruption LIC 1.

Introduction of this microcomputer communication unit made it possible to increase the control unit capability by 50 percent and ensure high reliability of system operation.

Microcomputer testing with a few dozen of EAX_s (more than 2,000 microcomputers produced) proved them reliable and the chosen technical decisions correct.

High Speed Cluster LAN for Professional Personal Computers

18630006E Budapest SIXTH SYMPOSIUM ON MICROCOMPUTER AND MICROPROCESSOR APPLICATIONS in English 1989 pp 519-523

[Article by S. W. Gorbachev and Y. E. Sheinin, Leningrad Institute of Aviation Instrument Making USSR, 190000, Leningrad, Herzena St., 67, LIAP]

[Text] Technical characteristics and economical limitations for high speed LAN based on PPC in network CAD and CAE systems demand new, not multidrop line, architectures. Cluster LAN architecture LENCLUSTER is proposed. High speed LANs for PPCs with total throughput from one up to tens of Mbyte/s may be constructed. Hardware for LENCLUSTER LAN construction—Network Communication Controller and Communication Network Adapters for PPC, are described.

1. Network Development Systems With PPC

Professional Personal Computers (PPC) are widely used for computer aided design and engineering. Microprocessor-based systems design is an example.¹ Most systems are product of the collective design. Stand alone

workstations do not correspond to collective nature of a design process. It is necessary to turn to based on LAN Network Development Systems (NDS). LAN must provide efficient designers interaction, shared resources usage (expensive i/o devices, magnetic tape and disc storage, computer and information resources). High speed devices, large storage, on-line information exchange capacity, response time limitations for user-system interaction call for high speed network. Rigid economical limitations are caused by PPC characteristics: network cost (per node) must not exceed 10-15 percent of PPC cost.

Homogeneous office LANs, based on a sole multidrop line of some kind, suppose uniform information exchange streams throughout the network. Such LANs are not efficient for NDS with PPCs: they are either too expensive (e.g., Ethernet), or too slow. High speed LAN design for NDS must take into account specific character of design process organization, of information streams, of typical NDS nodes location.

2. Cluster LAN Architecture

The main principal of cluster LAN “Lencluster” design—multilevel heterogenous system of interacting subnets, Fig. 1.

The low hierarchy level clusters are primary subnets, connecting small groups of user nodes with high-rate in-group communication (4-8 nodes typically). Designers team is usually divided into such groups. Members of a group are usually placed in the same room, at the distance not exceeding 10-15 meters from each other and from the group shared devices. Communication within a group is most intensive. It demands 5-10 Mbit/s (0.5-1 Mbyte/s) transmission speed within level 0 cluster.

Next level cluster are used for communication between groups of one team, working at the design. Communication between clusters are used for casual access to shared information resources. The inter-group communication rate is much less than in-group communication. Transmission speed requirements for level 1 clusters—0.5-1 Mbit/s. Distance between user nodes (i.e., for members of one team) can be limited by 100-300m.

Next level cluster connection corresponds to a different nature of user nodes interaction. It corresponds to interaction between teams—not hourly communication in there current work, but time to time requests-answers, issue requirement, etc. Transmission rate about some tens of kilobits per second is quite acceptable here. At this level, distance between nodes is large—they are spread all over facility.

3. PPC Cluster LAN Components

Component set for high speed cluster LAN was designed. They include Network Communication Controller (NCC), Communication Network Adapter (CNA) for user node PPC and Network Software Package.

Figure 1. "Lencluster" LAN

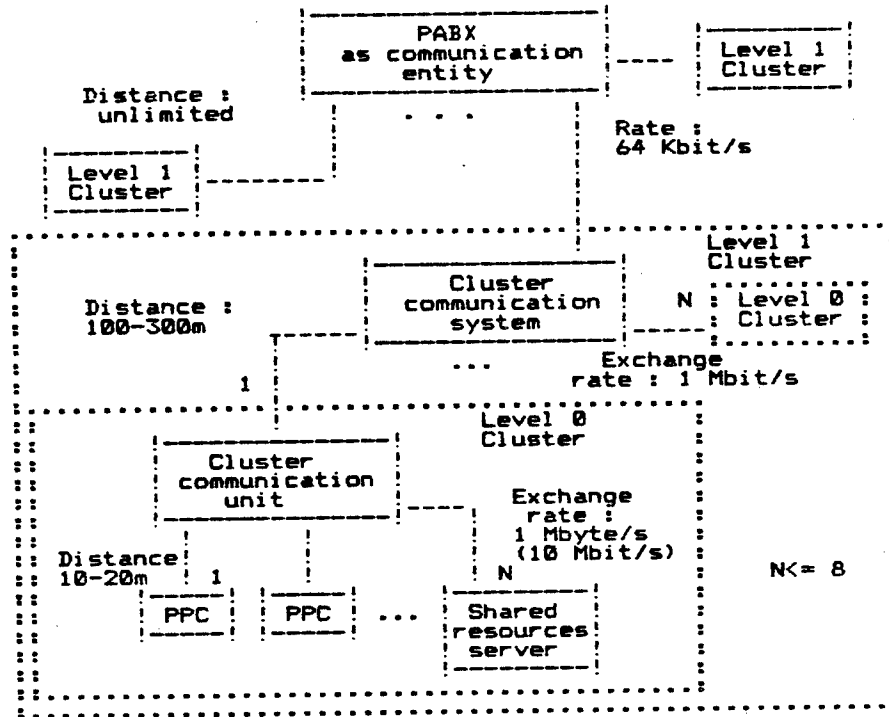
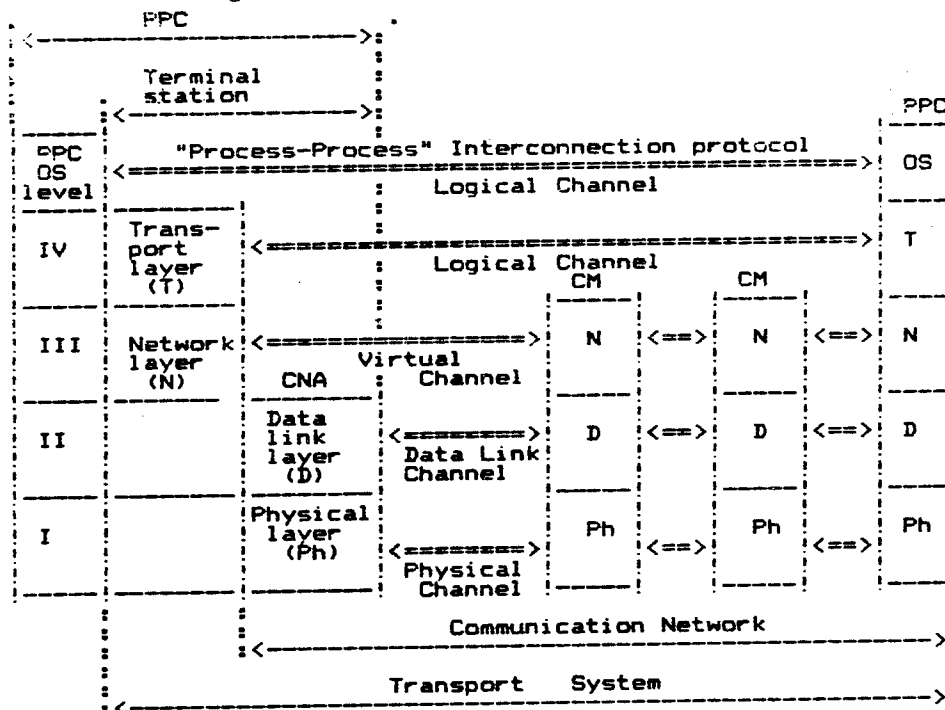

Figure 2. Protocol Architecture of "Lencluster" LAN



NCC designed for in-cluster communication between PPC and for inter-cluster communication for low-level clusters. NCC maintain direct communication with up to 8 nodes by parallel channel at the rate of 1 Mbyte/s. packet intermediate buffering in NCC (1,000 packets by 256 bytes per second), channel switching or adaptive switching.

NCC is based on transputer module RT841, built on high rate bit-slice microprocessor.² RT841 include 4 Kbyte RAM, 4 Kwords program PROM, 8 i/o units. RT841 with appropriate software in PROM implements NCC—a communication system for 8-node cluster. For distance less than 15 meters, parallel multicore cable (typically—flat cable) is used. For distance up to 300m the serial link—optical fibre cable, is used (8 Mbit/s). In this case the different plug-in i/o units are used in NCC.

CNA attach PPC to LAN Lencluster. One-board CNA implements data link protocol.

The third level cluster is a low-rate one. Special physical links throughout a facility for these level cluster is not justified. PABX can be used as communication entity in this case.³

[References omitted]

Microprocessor Shortage Hampers Personal-Computer Production

18630001 Moscow NTR: *PROBLEMY I RESHENIYA*
in Russian, 1989, No 20 (107), p 2

[Article by F. Vladov]

[Excerpt] From October 10 to 16, the Belorussian Scientific Production Association of Computer Equipment, the all-Union association "Eksposentr", the Central Committee of the All-Union Leninist Communist Youth League and the Minsk Municipal Center of Scientific

and Technical Youth Creativity imeni Masherov held in Minsk the first international symposium "Informatika-89" dealing with the development and use of personal computers (PCs). Within the framework of the symposium, a plenary session of the All-Union Society of Information Processing and Computer Engineering was held, as well as a meeting of the organizers of the International Computer Club, which, by the way, had sponsored the symposium together with the Soviet-American joint venture "Dialog" and the TsKSO "Radiotekhnika". And, finally, the international exhibition "Personal Computers-89", in the work of which about 90 firms from 16 countries took part, became a special attraction of the program.

As is shown by the research of well-developed countries, personal computers can and should be beneficial here: in stores and hotels, pharmacies and patrol cars, local Councils and libraries (and I'm not even speaking yet about the arena of material production). But in order that they appear in all such places, the number of them must not be in the tens or even hundreds of thousands, but in the millions.

But importing does not help in any way—it is necessary to create a new and sufficiently powerful branch of industry capable of producing personal computers in such quantities. As USSR GKVTI first deputy chairman I. N. Bukreyev said, the necessary power is being created now.

Perhaps the most vulnerable place of this program is the shortage, or even the complete absence of high quality microprocessors, similar to the "Intel" 10286 and "Intel" 10386 known worldwide. It is precisely this shortage which hinders the mass production of the ES-1841 personal computer and even more so the ES-1842 PC—the first Soviet machine meeting world standards.

(SNAP 891204)

Twenty Years of Cooperation of Socialist Countries in the Field of Computer Technology

907G0048A Moscow *NOVOYE V ZHIZNI, NAUKE, TEKHNIKE: VYCHISLITELNAYATEKHNIKA I EYE PRIMENENIYE* in Russian No 11, Nov 89 pp 3-21

[Text] The anniversary international exhibition "Computer Technology and Information Science" was devoted to the twentieth year of the cooperation of socialist countries in the field of the development, manufacture and use of computer technology equipment. This event is of great importance in the history of economic and political cooperation of countries of the socialist fraternity.

The need for rapid progress in such high-priority scientific and technical areas as atomic power generation, exploration of space, creation of basically new materials and technologies, and also for the solution of other important scientific and industrial problems, has acquired extreme strategic significance since the beginning of the 1960's. Without the creation of a basically new information science-computer environment these and other scientific, economic and political problems which are universal for the socialist community cannot be solved.

An objective requirement of maximal concentration of efforts of the entire socialist community has arisen in the field of information science and computer technology in order to overcome the current negative trends and to solve strategic problems in order to bring about the quickest possible advance to the world level.

With this specific goal in mind twenty years ago, in 1969, the governments of the People's Republic of Bulgaria, Hungarian People's Republic, German Democratic Republic, Polish People's Republic, USSR and Czechoslovakia signed a multilateral Agreement on Cooperation in the Field of the Development, Manufacture and Application of Computer Technology Equipment. In 1972 the republic of Cuba also became part of this agreement, and in 1973 the socialist republic of Rumania joined.

In order to realize the Agreement, leadership and coordination of the projects stipulated in it an Inter-Governmental Commission on Cooperation of the Socialist Countries in the Field of Computer Technology (MPK on VT) was formed, which consisted of national sections, which are formed by the governments of the countries participating in the Agreement.

The integrated scientific, technical and economic programs which were adopted in the framework of the Inter-Governmental Commission, which combined the national programs into a unified scientific and industrial complex, allowed realization of large projects, which would correspond to the interests of each fraternal country and of socialist cooperation as a whole.

During the implementation of these programs a large number of complex technical and technological problems was solved at the computer technology equipment design stage, as well as during preparation of the serial output, organization of maintenance and use of jointly developed computers. A microelectronics-based industry was created, a unified system of general purpose computers was developed, which includes 33 models with productivity from hundreds of thousands to 600 million operations per second.

It is expedient here to note the following.

A high-production complex based on a 32-bit minicomputer and matrix processor, (IZOT 1056 S and the IZOT 2001 S), which is intended for use in automated systems for engineering work and in FAM (flexible automated manufacturing) systems (Bulgaria).

The state information system for scientific research and experimental design work (OKR) based on a packet switching network (Hungary).

Adaptive automated design systems based on the 1057ES computer with ES 7945 graphics system, and also terminals based on the ES 1834 and SM 1910 personal computers with graphics peripheral device (German Democratic Republic).

A set of automated systems for the public health sector: KARDIOSID, NEVROSID, MEDISID 3M and so forth (Republic of Cuba).

Automated measurement and technological systems based on the VIRT—1016/2116 complex, image conversion system using the MAZOVIA-2032 computer software package, programmable industrial control system KFAP—LANIUP—PLC (Poland).

The system for controlling redundant industrial processes based on two CORAL 4024 and D707 computers (USSR).

An information science-computer complex for performing complex geophysical research, solving problems of mathematical physics and other scientific and information-intensive problems based on the ES-1068.17 super computer with productivity of 600 million operations per second, and also a situational complex for making administrative decisions, which includes artificial intelligence equipment in dialogue mode (USSR).

The adaptive problem-oriented complex based on the 32-bit SM 52/12 computer (Czechoslovakia).

An industry of systems and applied software has been created: operating systems, programming systems, data base management systems, various software programs.

The merchandise trade of the participating countries of the Agreement in the field of computer technology increased in 1988 in comparison with 1970 by a factor of more than 40.

In order to enhance the socialist integration, to support the scientific and engineering potential of the CMEA member countries for joint solution of problems of developing computer technology equipment at the level of the best world achievements in these fields a General Agreement on Establishing the International Center on Information Science and Electronics (Inter-Computer) was signed in October of 1987. (Moscow, USSR Exhibit of National Economic Achievements, May 29, 1989).

PEOPLE'S REPUBLIC OF BULGARIA

New computer developments, highly productive complexes, custom processors, prospective 32-bit mini- and micro-computers for different purposes were demonstrated at the exposition.

External memory devices on magnetic disks and tapes, input/output information devices, as well as data preparation devices were presented.

In addition, the exposition contains a number of new matrix processors with high productivity, an arithmetic processing module, which maintains communications between processors, for developing a single memory.

A number of terminal stations was demonstrated, which provide the possibility of remote access. Flexible manufacturing systems (GPS) are presented which are based on a 32-bit computer to solve scientific, engineering and economic problems.

The exposition includes more than 50 exhibits. Among them are: a highly productive complex based on the EX 1037 computer and matrix processors; multimodular matrix processor ES 2709; highly productive complex based on a 32-bit minicomputer and matrix processor (IZOT), which is intended for use in automation systems; a color graphics display station SM-7411. A wide variety of software for quite diverse purposes.

PEOPLE'S REPUBLIC OF HUNGARY

The exposition of the People's Republic of Hungary, which includes eleven companies, demonstrated peripheral devices, network computer interfaces, ES computers and other computer technology equipment, which provides automation for the industrial and consumer areas. The State Information System for Scientific Research and Experimental Design work based on a packet switching network is of great interest.

The software is distinguished by diversity of software products, which are used to manage data bases, automate production processes and integrated services for citizens.

Developments at the expositions of the companies EGSZI, NOVODATA and BUDAVOX are of interest.

The company NOVODATA is a Budapest cooperative on computer technology. It has seven years of experience in developing semiconductor memory devices. The exposition presents a family of these memory devices for

users of the ES line of computers (ES 1022, 1023, 1030, 1033, 1040, 1045, 1055, 1055M), which have capacity of 4, 8 and 16 MB. Each system of a family contains, in addition to the RAM, additional memory. A high technical level of the memory devices, very good reliability indicators, minimal power consumption and minimal sizes are provided.

Memory systems of the company NOVODATA are working in Hungary (30 sets), in Czechoslovakia (40), in the USSR (2 sets). The company has been delivering systems for ten weeks.

The motto of the company NOVODATA is: "for each Winchester, which exceeds 20 megabytes, ND-2A20M streamer!" The streamer retains on magnetic tape in the cassette 20 megabytes of data. One variant of PC-DOS 2.0 or support by another system is adequate for use. It does not require an individual board for mating, for the control management program suffices. It is freely placed in the computer housing in place of a disk drive, and half-height is sufficient.

Technical parameters are:

- capacity of 19.5 MB; 10.0 kb/unit; 1.0 kb/selector;
- mean time between failure is 10,000 hours;
- interface: SA-450/standard floppy.

ND-3272 controller. A shortcoming of ES computers is the small amount of remote processing equipment that can be connected to it which is produced in the socialist countries. NOVODATA cooperative has suggested a group terminal control device ND-3272. In the basic configuration this device connects to a computer multiplexing channel 8, and in expanded configurations 16 integrated terminals. The cable length between stations can be up to 1 km.

Printers of NOVODATA company are the SLIP ND-SP44 and ROLL RP114, which have the best certification based on Hungarian standards. The printing speed is 60 characters per second (for the ND-SP44) and 2.1 lines per second (for the ND-RP114).

The printers can be used with any computer on site or at a considerable distance from the computer. It is connected through the RS-232C interface. They are not sensitive to careless handling.

For buyers and sellers. The marketing system with the NOVODATA computer, NOVOSHOP, is something new in the trade. It is suitable for recording merchandise trade for a small store, as well as for large department stores; it handles all kinds of information on sold goods (the line code of the product, group code of goods, internal code); it records requests of the shopper, number of delivery, stock number of a delivered product; continuously monitors the passage of product from arrival to its sale: storage in the warehouse and delivery to the retail floor, marketing, advertising, reverse crediting.

By using the NOVOSHOP system one can monitor delivery of the product, cycle, reserve supply and time to be sold.

The largest configuration of the electronic cash register apparatus HELIOS-All is based on the HELIOS-All devices and a computer network of the IBM PC/XT, AT or PS/2 type, which integrates the cash registers. A storage capacity of 30 megabytes is required for continuous display of information of 1000 clerks and sales of 100,000 items for one day.

The consumer also receives important services by use of the NOVOSHOP. It is easy to record cancellations or to figure taxes for product purchases. One can use magnetic tape or check for payment of accounts, and in this way one can monitor closed accounts.

The company EGSZI acquaints visitors to the exhibit with line code systems and experience of their use in retail trade, at warehouse, and in libraries.

Company BUDAVOX TERTA

The TMT-125 matrix printer. It is produced by license arrangement, purchased from the company Mannesmann-Tally (Austria). It can be used as a peripheral device in a microcomputer and low productivity computer; in data collection systems; as an output device.

It can be used with great effectiveness in remote data processing systems and as an output peripheral device. The configurations and parameters of the printing symbols of the printer can be changed by the program. The printer has a programming control. A red tape is located in a cassette that is easily replaced. Operating lifetime of the tape is not less than two million symbols.

The TMT-125 device is manufactured in two forms: TMT-125 MFF (manual) and TMT-125 SAFF (semi-automatic).

The network computer WANPBOX TPS-1 allows one to connect asynchronous work stations for a computer to a network with packet switching. Configuration of the equipment is done by the customer.

VIDEOTON Company

Personal computers, which are compatible with the IBM PC/XT. The spectrum of VIDEOTON products has been expanded by a family of personal computers. New members of the family are personal computers VT110, VT160, VT180, which are completely compatible with the IBM PC/XT and the AT. A full set of programs, written in the operating system MS DOS 3.X is used in these computers.

These personal computers are intended to satisfy the increasing user requirements for quality and number of computers. They are used as separate, independent computers, but they can also work as part of a work station in local networks, which are capable of solving technical

and various administrative problems at a modern level, that is they are reliable, quick, effective and profitable.

The flexibly arrangeable configurations of these computers and available user programs ensure a wide area for their application.

Hardware

The base device contains the mechanics, main board and power unit. The average configuration includes one floppy disk driver for magnetic diskettes with capacity of 360 KB and 1 Winchester type disk with capacity of 20 MB. A black and white or color monitor is used to display information. Controllers are necessary to control these peripheral devices. Room is provided in the mechanism for two floppy disk drivers or two hard disk drivers with half-height size. In place of a floppy disk one can connect a streamer with 20 MB capacity for the VT110 and 60 MB for the VT160 and 180. A low-noise speaker is used to supply sound signals.

The main board

The four-layer piece board contains the 8088 type microprocessor (VT 110), 80286 (VT160 and VT180), 640 KB RAM (for the VT180, 2MB), BIOS (Basic Input Output System) permanent memory with 8 KB (VT160 and VT180, 32 KB), input at 7 interrupt levels (VT180, 16 levels), 4 DMA channels, keyboard interface, real time clock and auxiliary electrical circuits.

Display apparatus

Various applications require various possibilities for resolving capability and number of colors.

The MDA black and white controller and monitor:

- graphic capabilities of the controller are compatible with Hercules graphics;
- a 9-terminal plug connection for PGBITTL signal and CENTRONICS type printer parallel interface is installed in the controller;
- there are 256 kinds of characters available in the character generator 8 kilobytes for permanent memory;
- resolving capability is 720 X 348 points.

Software

The VIDEOTON delivers computers with MS-DOS 3.3 operating system and GW BASIC programming language.

The VT 32X family of computers is modern equipment for automation of design organizations, which offers a wide spectrum of services and equipment to equip a technical design environment.

Currently the VT 32X family consists of the VT 32 system and the VT 320 system. The VT 320 computer,

while retaining compatibility, is characterized by considerable power and expansion of functions. The speed of the processor has doubled, and operations with a floating decimal and mathematical functions are supported by the hardware. The amount of on-line memory is 4 MB, but it can be expanded to 8 MB.

As in the VT 32 so also on the VT 320 in accordance with the tasks one can create different system configurations, that is the work stations for several users (6 to 8 users for the 32, 12 to 16 for the VT 320), who are involved in document preparation and doing office work.

The main characteristics of the VT 32X family are:

- open architecture and structure, which allows one to create systems for different purposes, power and configuration;
- widespread use of standards;
- powerful graphics to support design tasks on a computer in dialogue mode;
- high-speed local network, which allows one to create large distributed systems.

GERMAN DEMOCRATIC REPUBLIC

Dresden, the residence of the Saxony kings, is today the center of a modern industry, electrical engineering, electronics, machine building, and also research work and education. Three modern complexes of buildings, on the roofs of which from far away one can see the sign Robotron are located on an internal beltway of the city of Dresden, along a major north-south transport highway. The Dresden Robotron-Elektronik enterprise is located here, the main enterprise of Robotron, and also two other enterprises of the trust involved in development of supporting materials: Dresden Robotron-Design and Robotron-Messelektronik imeni Otto Shoen.

Another traditional local or company name involved in the production of computers or office machines is the company Zaydel' and Naumann in Dresden.

Enterprises of the trust which are located in Dresden are only a part of the economic association Robotron which was created in 1969. In order to name all of its components one would need a map of the GDR, and in order to indicate all of its users one would need a map of the world.

The People's Trust Robotron, which is the leading economic enterprise of the GDR, is a developer, manufacturer and exporter of devices, installations and applied solutions in the field of computer and information technology, communications equipment, measurement and consumer electronics, and also office mechanization and drafting equipment. Robotron Trust pays particular attention to the development and creation of automated production control system work stations, in particular ones used for the construction industry, machine

building and product design. In a short period of time Robotron Trust has gained world-wide recognition.

Based on such important agreements within the framework of CMEA, such as the Unified System of Computers (ES EVM) and the System of Small Computers (SM EVM), to the present time Robotron has created and successfully tested more than 100 computers, devices and programming systems. Compatibility of all this equipment with one another has been ensured.

The Soviet Union with an export volume of more than 400 million rubles per year is an important trade partner of Robotron. The export of electronic computers ES 1055, ES 1055M and ES 1057 as integral parts of the series 2 and 3 of the ES line of computers has played an important role.

For example, in 1984-1987 the comprehensive program of "Computer Technology in Banking" ordered by the USSR State Bank in Moscow was implemented. Because of this action, two million accounts can be managed daily in 100 Moscow branches, and 350 thousand documents can be recorded, and 500 account balances can be compiled. Continuation of the scientific, technical and economic cooperation on this project up to the year 1990 has been agreed to.

Based on these agreements Robotron People's Trust has implemented three transport projects for Georgia SSR involving hardware and software equipment of the trust.

At a milling machine plant in Gor'kiy, which is equipped with units produced in the GDR, computers of Robotron Trust control the entire production.

There has been successful cooperation of Robotron Trust with Soviet automobile industry since 1982. In accordance with requirements of the USSR automobile industry a system of devices entitled "problem-oriented integrated system for preparation of manufacturing data" (POK SPPD) has been created. In addition to the Dmitrovograd plant of automated units, where testing of the first configuration of the problem-oriented integrated system for preparation of manufacturing data began in 1984, one can include as customers of Robotron Trust equipment, such important automobile plants as the plant at the city of Tol'yatti, KamAZ in the city of Naberezhnyye Chelny, the Gor'kiy automobile plant and AZLK "Moskvich" in Moscow.

New areas of cooperation to accelerate scientific and technical progress and in establishing direct connections are underway. For example, Robotron granted a license for the production of electronic typewriters ELEMA with memory to the typewriter plant Pishmash in Kirovograd. One should also emphasize the successful cooperation in joint development of operating system for peripheral devices of the ES computers, which has been carried out with NITsEVT.

Next we give information on exhibits and projects, which the Robotron People's Trust will present at the International Anniversary Exhibition in 1989 in Moscow.

A transition from 16-bit to 32-bit architecture has been accomplished by development of the 32-bit SM 1710 computer. An effective multiple user system has thereby been created, the use of which is stipulated primarily in the field of automated production control systems and flexible automated manufacturing (SAPR/GAP). Labor productivity can be increased up to 500%, and expenditures for research and design can be reduced by up to 20% by the use of such automated production control work stations in the field of planning and design, for example in machine building, electric engineering and electronics.

The very powerful SM 1710 minicomputer (K 1840) is a 32-bit minicomputer with virtual memory, with a qualitatively new architecture and operating system. Its particular advantages includes the possibility of displaying graphics information in three-dimensional form.

Systems software includes two operating systems: the main operating system SVP, which operates on a real time scale, and the interactive subscriber system MUTOS 1800 (compatible with UNIX system). Each operating system provides management of the corresponding data banks.

For the work of local and global networks there are network routine programs, which ensure operation of 8- and 16-bit personal computers with the SM 1710.

The main characteristics are:

- speed of about 1 million operations per second;
- physical working memory from 2 to 16 MB;
- virtual memory up to 4 GB;
- expanded external memory up to 3 GB in combination with high speed of data exchange up to 2 MB/sec;
- sophisticated input/output system;
- possibility of arranging multiple user, multiprogram and package modes of operation, use of memory traffic manager, organization of priority and time-quantized processing of assignments.

Electronic Typewriter

The compact typewriter "Erika elektronik 6007" can be used at home or as a second machine in an office. It can be converted from a typewriter to a modular system by simple switching of different modules. The memory module allows one to increase the internal memory capacity to 4400 characters. This means that one can store up to two pages in memory with no difficulty, which eliminates the repetitious labor for frequent retyping of text.

In order to use the machine as a printer one can use one of the two interfaces which are most widely used in the world: Centronics (parallel interface) or Commodore (serial interface). When using the invoicing module the compact typewriter immediately becomes a professional automatic bookkeeping machine. The Erika is equipped with quickly changeable cassettes for letter wheels and a drop-in type ink ribbon.

The models of the 3004, 3005, and 3006 typewriters have simple control function. They are distinguished by an attractive design and small dimensions. The smallest electronic typewriter is the Erika portable.

IMAGE-C Image Processing System

New technologies and methods include the use of image processing systems. Robotron is aware of the increasing importance of image processing systems for science and technology, and in close cooperation with scientific establishments of the GDR is producing hardware for processing images and is also developing the necessary software for them.

As part of a new project Robotron offers a high-production image processing system based on a 16-bit professional personal computer, the Robotron ES 1834. They have accumulated solid experience in the use of such systems. We shall present only a few examples. We were witnesses to one of the important moments in a space mission, the interplanetary stations VEGA 1 and VEGA 2 which flew by Halley's Comet at a distance of 9000 and 8200 km from the nucleus of the comet. The stations transmitted more than 1000 images, which were analyzed using the Robotron A 6470 image processing system installed at the USSR GOSNITsIPR. The image processing system was used in Moscow, permitted the determination of data by volume and structure from the nucleus of Halley's comet in a very short period of time.

Another example. The goal of developing a system solution for remote prospecting of the earth was the creation of conditions for efficient and extensive analysis of multispectral photographs of the earth. These kinds of photographs were obtained, for example, from the multispectral Soviet spacecraft of the Landsat type, and also from the multispectral cameras MKF6 or MKF6M onboard the famous Soviet spacecraft Soyuz and the space laboratory Salyut.

This system is irreplaceable for the automated analysis of photographs in medicine and biology, and in materials science. In the field of histology and other biomedical fields the possibility of automatic analysis of microscopic photographs has become possible by using the Robotron A 6470 image processing system and AMBA/R software package. This is an important auxiliary piece of equipment for highly specialized diagnostics and monitoring.

Hardware of this system.

The processing device is constructed according to the modular principle, offers access to individual points of an image, with image memory of 768 X 512 X 8 bits.

Functions of this device:

- operations on points of an image during recording, sensing and making of the supplemental code;
- operations with fragments during recording, sensing and erasing;
- magnification in the direction of both coordinates, with steps from 1 to 16;
- alignment of an image with different kinds of cursor;
- programmable color tables for simultaneous representation of 256 color shadings from a total range of 262,144 color values;
- representation of any image fragment from video memory;
- protection of recordings, individual protection for each level of bytes;
- axis time to memory: 80 nsec in the case of line axis, 640 nsec for other axis.

The YENAVERT translucent microscope. K 6314 printer.

The software package for experimental work with the multispectral images at the interactive level currently includes 90 elementary functions for processing and analysis of images. The monitoring program IPU (Image Processing Utility), independently of servicing organizes all necessary control operations in the computer system. The software program was developed in such a manner that specialists of different branches of science, who do not have programming skills, can use it and create application solutions.

IMAGE-C is written in C programming language. The programs, which are offered in Fortran and Pascal languages, can use IMAGE-C routine subroutines. The system is supported by standard operating system MS-DOS.

Software Output

Robotron Trust has been one of the largest producers of computers within CMEA since the beginning of computer manufacturing. In 1984 a special enterprise was created for software, where in accordance with the manufacturing profile software began to be developed for all of the computers produced by Robotron Trust. Primarily operating systems and standard software packages.

In the spring of 1989 at the Leipzig Fair at the Ministerial level there was an agreement made on creating the first joint socialist enterprise of the GDR and USSR, TsENTRON.

This joint enterprise of the Robotron People's Trust and the scientific and technical association Tsentrprogrammssystema is a scientific industrial center for development, delivery and maintenance of software and information processing systems.

The assignments of the general enterprise TsENTRON include development of programming complexes and systems for various industries: metallurgy and public health, petrochemical and banking, in which the hardware part of computers, super powerful minicomputers and personal computers of Robotron Trust will be used.

THE REPUBLIC OF CUBA

Computer technology hardware and software were presented at the exhibit of the Republic of Cuba. The use of computer technology systems in public health, teaching systems, systems of international financial accounting, athletic statistic systems and others, were demonstrated, which allow one to obtain an improvement on efficiency and growth of productivity of socialist labor.

Medical diagnostic equipment using computer technology and a series of alpha-numeric and graphic terminals were demonstrated at the exhibit. A broad array of keyboards for personal computers were presented.

The SM8541 channel switching device using standard serial interface RS 232 unites up to 8 personal computers in a local network system, which gives the user the following capabilities:

- transmission of files and message;
- execution of programs, remote personal computers;
- shared use of printer resources.

Serial input/output channels of the personal computer switching devices can be connected to IBM PC computers which are compatible with ones that have MS-DOS and CP/M operating systems with serial output interface. The switch can be selectively controlled by the printer with parallel interface for any of the 8 channels.

The data transmission rate is selected by using microswitches. The channels are combined into three groups depending on speeds. Any of the following data transmission speeds is possible: 300, 600, 1200, 2400, 4800 or 9600 bits per second.

The user is offered the following possibilities:

- establishment of a connection;
- disconnection;
- condition (reporting on the condition of connection);
- distribution (simultaneous transmission of files and messages to all personal computers connected to the switching devices is carried out);
- printing;

—remote processing.

The switching device monitors correct operation of the system, indicating the presence of an error.

FUZZI-EXPERT. This is a software package which allows one to determine and build one's own expert system. It is basically directed at selecting the technical and economical alternatives, and also for modeling and stimulating technological processes. The system is powerful and a very flexible tool.

Intelligent editor. This is a software program which allows one to enter any kind of data in simple form into the database.

FUZZI-EXPERT is a product made by ICIDCA company, and is delivered by CUBAELECTRONICA.

PEOPLE'S REPUBLIC OF POLAND

In the 1971-1975 period exports for Poland in the field of electronic computer equipment reached the level of 155 million rubles. In the next five-year plan 1976-1980 the deliveries were already on the order of 526 million rubles.

In 1981-1985 the member countries of CMEA delivered computer equipment at a cost of about 1 million rubles, and the present volume of deliveries allows one to assume that during the current five-year plan (1986-1990) exports in the amount of about 2 billion rubles will be completed.

The USSR occupies first place among Socialist countries geographically with respect to exports of electronic computer equipment. In the first period (1969-1980) peripheral devices were delivered to the USSR. For example, mozaic type printers from the plant MERA-BOONE, floppy disk storage devices from the Cracow plant KFAP, video display terminals and input/output stations from the factory MERA-ELZAB cassette tape storage devices from the Warsaw plant MERAMAT were delivered.

In the subsequent years (from 1980 on), in addition to peripheral equipment, minicomputer problem-oriented complexes MERA-KAMAK SM-4, SM-1300, and recently the SM-2420 produced by the Warsaw ERA have formed a large part of the delivered items. These microcomputers, which are connected to KAMAK modules, are equipped with a side assortment of peripheral devices and alot of software. They are used in many branches of science and the national economy.

The Polish computer industry in cooperation with Soviet institutes and plants has developed a number of specialized mini-computer systems, including systems for automated scientific experiments using KAMAK equipment, and also teaching systems. There are already several thousand such systems in the Soviet market. They are used at the Joint Institute of Nuclear Research at Dubno,

at the Siberian Branch of the USSR Academy of Sciences, at many institutes of the Ministry of Higher Educational Institutes and other places.

In recent years microcomputer systems Mazoviya 1016 and 2016, Silesia and new systems for designing MSVP and RTDS have been offered for export. Deliveries of local and remote networks, subsystems or remote processing of data for the SM computers (TeleSM) have begun. In the field of peripheral devices new types of mozaic printers and printing terminals, video terminals, floppy disks of the slim-line, PT-310 type tape storage devices, plotting board and roll-type graphic plotters (MGD-1, MERA-621, MERA-630), and wide range of power supplies for mini and microcomputers, keyboards of various designs have been offered.

In order to satisfy requirements of Soviet customers for technical servicing of the delivered systems and devices, in 1983 in Moscow the Trade and Technical Center was founded, which does work on service maintenance and training of specialists, Soviet users, as well as technical and commercial services of the Polish representatives in Kiev, Leningrad, L'vov, and Novosibirsk.

The VIRT measurement system. The VIRT measurement system is intended for automation of the gathering and processing of physical quantity measurement (voltage, current, frequency, temperature and so forth).

The VIRT system can be successfully used in scientific and technical studies, to monitor product quality and industry, and at servicing, manufacturing and other organizations. The VIRT system can also be used as a system for controlling industrial processes.

In its full complement the VIRT system includes:

- MAZOVIA SM 1914 personal microcomputer (or other microcomputer, compatible with the IBM PC/XT/AT);
- custom interface circuit boards;
- set of measurement modules, from which the measurement system for a given application is made up;
- system software, which controls standard input/output devices and measurement modules;
- application software, which corresponds to a given use of the system.

The VIRT system can be delivered as a problem-oriented complex, that is with the necessary sensors and convertors of physical quantities. The software of the VIRT system contains equipment for independent development of application software by the user.

This system has not been delivered to the USSR.

The MAZOVIA 2032 personal computer.

The main fields for the use of the 32-bit personal microcomputer MAZOVIA 2032 are:

—automated design systems (CAD, computer aided design); desk-top text editing; control of large databases; interactive processing of images; work with many users.

Technical description.

The MAZOVIA 2032 microcomputer consists of a systems unit, display and peripheral devices. The systems unit can be produced in desk-top embodiment or in the form of a rack. The composition of the systems unit as a microcomputer includes the following functional subassemblies:

- JC-M386 processor or with 2 MB capacity ZUPV (memory) (offering the possibility of expansion up to 16 MB) and with 8 system interface slots;
- display controller board;
- JS-ND/FD floppy and fixed magnetic disk storage controller board, which interacts with a 16-bit main bus;
- JS-S/P serial and parallel interface controller board;
- 360 KB and 1.2 MB capacity 13 cm floppy disk drives;
- 40 MB capacity 13 cm fixed disk drive with access time of 40 milliseconds;
- 240W rated power supply.

The systems unit is equipped with systems interface, which includes:

- four 8-bit slots (corresponding to the IBM PC/XT);
- four 16-bit slots (corresponding to the IBM PC/AT).

It is delivered in the USSR.

The exhibit of the Polish People's Republic offers varied ES and SM computer technology equipment, including a series of programmable personal computers and various peripheral devices. The use of computer technology systems is demonstrated in networks using the ES computers for the TELE ES data remote processing subsystem and also network problem-oriented complexes using minicomputers (SM computer systems).

The MAZOVIA 2032 prospective 32-bit programmable personal computers were shown in several interesting applications: for publishing work, in the VIRT measurement systems.

The use of SM computer and PPEVM (programmable personal computer) system microcomputers in systems for automation of scientific research experimental planning, in automated engineering calculation and automated design systems, enterprise control systems and automation of administrative and office work, and also for teaching purposes was also demonstrated. The exhibit included microprocessors debugging systems and auxiliary design equipment.

In addition, the exhibit included a system for testing digital integrated circuits, ARM for designing printer circuit boards, a system of digital processing of images (example of its use in medicine), and a microcomputer subscriber telex station.

The MAZOVIA 1016 microcomputer (SM 1914), produced by the Industrial Trade Enterprise MIKROKOMPUTERY is a 100% functional analog of the IBM PC/XT standard which is most widely used in the world and allows one because of its efficiency and speed to perform a wide array of problems, from text editing to creation of data bases for engineering calculations and design work.

The MAZOVIA 1016 microcomputer is delivered in several hardware configurations, which allow the customer to use it based on specific requirements, and also to expand its capabilities by increasing the complexity of the problems that can be solved.

The main version of the microcomputer system MAZOVIA 1016 includes the following: systems unit; single-color MMI 2P display; KL-10 keyboard (KL 12 serial) keyboard; D-100 PC printer.

Technical parameters.

The systems unit has: Intel 8086 microprocessor; RAM with 640 KB capacity; two floppy disks with 360 KB storage capacity each; Winchester type magnetic disk storage with capacity up to 20 MB; interfaces: serial RS-232C and parallel Centronics; unified display controller, which operates in CGA graphics mode and Hercules mode (with resolving capability of 640 X 200 and 720 X 348 respectively).

Single-color display, 720 X 350 lines, 30 cm along the diagonal, has possibility of working in character-alphabet and graphic modes.

Keyboard with 84 keys. D 100 E/PC printer, printing speed 25 characters per second.

The basic version of the computer can be supplemented by the number of external devices, which will substantially expand its functional capabilities.

The MAZOVIA 1016 microcomputer works under the control of MS DOS operating system and its Polish language version DOS-PC.

SOCIALIST REPUBLIC OF ROMANIA

All CMEA member countries to a greater or lesser degree are engaged in the development and production of powerful 32-bit computers. The majority of the exhibits contain either their mock-ups, operating systems, or software. There is such a system at the Rumanian exhibit, which is the CORAL 8730 minicomputer (mass production since 1988), which is intended for solving tasks which require large computer capability. Among such tasks are automated production control systems,

industrial technology systems, gathering of data, operation in computer networks, economic and scientific and technical calculations. The CORAL 8730 manufacturing enterprise is ICE-FELIX (Bucharest).

1. Composition:

- 8730 processors;
- MOS memory module 4MB with controller;
- magnetic disk controller;
- magnetic tape subsystem;
- multifunctional interface;
- 160/330 MB Winchester disk;
- 1200 line per minute parallel interface;
- video terminals (VDT 240,125,232,525);
- communication interfaces.

2. Specifications.

Central processor:

- operands are 32 bits;
- operational register are 16;
- addressing are 12;
- interrupt priority levels are 31;
- number of instructions is 304.

Internal memory:

- circuit module of 4 MB.

The GT 300 graphic station is intended for connection to a computer or a minicomputer with graphics device with high speed and resolving capability, which operates according to GKS standard. The manufacturing enterprise is ICE-FELIX (Bucharest).

Composition:

- image generating and display unit and graphics processor;
- alpha numeric monitor;
- keyboard;
- graphics monitor with large resolving capability (single-color or color);
- graphics board;
- graphics programmable unit.

Technical characteristics:

- high speed graphics processor;
- 32 bytes;

- 50 MHz video band, 20 nsec/pixel;
- addressable points 224 X 224;
- color gamut 256 of 16 million;
- vector generator at speed of 3.2 M pixels/sec;
- serial or parallel interface 8/16/32 bits.

Two other interesting projects should be noted, which were presented at the Rumanian exhibit, which are associated with the computer interface devices: printer and plotter.

The IMPACT printer. Increased speed of 300 CPS for the module and 66 CPS for NLO and increased buffer memory capacity permit increase of working speed and make it possible to have direct transition to the next stage of operation.

Capability with EPSON printing devices permits expanded use of the item, which might be connected to any device of the IBM PC queue.

The PIF-01 plotter. The PIF-01 is a graphics plotter, intended mainly for design systems. It is distinguished by special characteristics with large formats from A4/A up to A/E, simple operation, high quality of the figure, and improved reliability.

The PIF-01 graphics plotter is easily connected to your personal computer, and also to the configuration of your system.

Recording of the drawing scale is done automatically, including the possibility of leaving the format. Support for drawing is varied: Mylar, tracing paper, punched tape, film or even acetate film.

Complex functions can be performed by means of the specialized DM/PL PIF-01 processor with relatively simple instructions.

UNION OF SOVIET SOCIALIST REPUBLICS

The large exhibit of the USSR does not allow one in this limited space to give even brief summaries for the many Soviet software and hardware projects. We shall limit our description to only some of the exhibits, which from our viewpoint are the most valuable.

SOFTWARE

Package of scientific programs for personal computers (software application programs for microscientific program packages). This package is intended for solving applied computational problems which are frequently encountered in engineering practice and scientific research.

By using them one can perform:

- simplest statistical processing of data;
- multidimensional regression;

- approximation and interpolation;
- numerical integration;
- construction of graphics;
- solution of nonlinear equations and so forth (16 kinds in all).

The package is written in Turbo-Pascal and Fortran-77 languages. For operation of the package one must have the Turbo-Pascal compiler. It is oriented to work on the Robotron-7150 computer and other personal computers, whose operating systems are compatible with the operating system of the IBM PC CMS/DOS version 3.20.

The software application program "interactive equipment for handling and displaying data" (PPP INTERSVOD). It is intended for highly efficient automated work stations of users who maintain databases in dialogue mode.

INTERSVOD expands the capabilities of using AIST, DISOD, and SUBDON type databases, by providing the user with means of dialogue interface directly with the database.

All operations of refreshing information and performing management operations are carried out with minimal amount of required manual manipulations, in which each action of the operator is immediately displayed on the screen. The information of the database is displayed by the INTERSVOD complex on displays in a form which is customary for the operator.

The application program functions in the ES and 7 ES (BOS) operating environments. In order to arrange group servicing one can use any easily available television monitors.

The programs of the package are compiled in assembler and provide short reaction time to operator queries.

The time for learning procedures of PP INTERSVOD with the goal of using them does not exceed 8 hours. The time for learning INTERSVOD language for the purpose of compiling database processing procedures is 15 days.

The dialogue unified mobile operating system DEMOS 16.2. It is intended for widespread use in different systems for management and processing of data and ensures multiprogram, multiuser modes, as well as having sophisticated tools for developing programs.

DEMOS 16.2 is an important functional expansion of the DEMOS system.

Use of the DEMOS 16.2 system allows the user to use computers with great efficiency, and improves functioning reliability of developed automated control systems.

Standardized operating system (UOS). It was developed by the USSR Academy of Sciences Institute of Information Science Problems for 16- and 32-bit personal computers, type ES1841/ES1842, IBM PC/XT/AT386, PS/2 or models that are compatible with them.

It ensures working in multiprogramming for application programs, instrument and service equipment, which operate in the Alpha-DOS operating environment and systems similar to it (MS/DOS or PC/DOS type). It allows one to perform service dialogue in any language (basic languages that are kept are Russian and English).

HARDWARE

Internal memory subsystems for storing discrete information.

Subsystems of the ES 5063.1 and ES 5065.1 work with magnetic disks. They are intended for storing information in modules of the ES computers Ryad-2, -3 and -4. The Winchester type magnetic disks with information module with capacity of 317.5 and 635 MB. The surface density for recording information is not less than 9250 bits/mm² (longitudinal density is 246 bits/mm).

Storage on magnetic disks ES 5312 with diameter of 130 mm with direct access. Unformatted capacity of 51 MB (longitudinal density 401 bits/mm). Another such storage device is the ES 5316.01, which includes a package of magnetic disks (8 items) with unformatted capacity 349 MB (longitudinal density of recording is 450 bits/mm).

Magnetic tape storage devices ES 5027.01/ES 5527.01 (ES 5027.01 is a storage device, ES 5527.01 is the control device). Up to 8 ES 5027.01 storage devices are connected to computer channels with transmission speed no less than 500 KB/sec. Information capacity of a reel with tape is 40 MB (with phase encoding) and 150 MB (with group encoding).

Computer Complexes

The complex for input and digital processing of images based on SM 1650 computer equipment. It is intended for solving problems of digital processing of images in different branches of science and technology, including metallurgy, biotechnology, instrument manufacturing, astrophysics, video communications, technology control and so forth.

The complex ensures: reception, display, numbering and storage of black and white half-tone images on the screen of a video monitor; implementation of different algorithms for processing images in interactive mode.

It consists of two main functional subsystems: input and digital processing of images (image subsystem), and central control.

The composition of the SM 1650 software includes: operating system; application program for interactive

processing of images; application program for metrological support; application program for test support; library of subroutines for working with technical equipment of the image subsystem; control system for performing functions of image processing.

Fortran and Assembler can be used as the programming languages.

Certain data include:

- time for execution of nonlinear point transformations of brightness of a single frame with dimensions 512 X 512 points is 40 msec;
- time for executing arithmetic-logical transformations of one and two frames is 40 msec;
- time for executing a scan with a sliding window is 3 X 3 points of a single frame with program assignment of coefficients, 40 msec;
- amount of graphics memory (512 X 512) X 3 bits;
- amount of on-line archival storage of images is up to 10 MB.

The SM 1425 computer complex is a new model of the family of 16-bit small computers, has great productivity and reliability, has small overall dimensions, mass and power consumption.

The SM 1425 command system includes SM 1420 commands and commands for organizing Supervisory supplemental operating mode. In place of the common bus, the systems interface of preceding models, the SM 1425 complex uses a 22-bit main bus parallel interface. The complex is equipped with modern peripheral devices with excellent technical characteristics. The compactness and low cost of the complex makes it similar to the class of microcomputers.

Two standard complexes of the SM 1425.01 and SM 1425.02 are planned for the initial period of production, and they are distinguished by the amount of on-line and external memory. New configurations will be developed on the basis of operating experience with the SM 1425 along with the development of hardware and software.

The processor ensures multiprogram operation in real time and time sharing mode. The multiprocessor computing complex for macroconveyor data processing, ES 1766. It is intended for solving a broad category of complex scientific, engineering and economic problems which require super-high productivity with processing of large amounts of information.

It consists of the high capacity ES 1066 general purpose computer and ES 2701 macroconveyor data processing multiprocessor.

The ES 2701 multiprocessor includes the following which are joined by a switching network:

- from 48 to 192 arithmetic processors with ES computer command system and on-line memory with capacity of 2 MB in each processor;
- from 8 to 32 control processors with command system oriented to control of parallel calculations.

The SM 1700 computer complex. This complex, based on the 32-bit 1700 minicomputer, is intended for use in systems of automated design, flexible automated manufacturing, in systems for automation of complex scientific research and processing of scheduling-economic and accounting-statistical information, in automated industrial control systems, in information-retrieval and teaching systems.

The SM 1700 minicomputer includes a central processor, from 1 to 5 modules of virtual memory (OZU), a processor with floating decimal, magnetic disk storage controller, and multifunctional communications controller.

The SM 1700 programming devices contain: MOS VP, DEMOS-32 operating systems; diagnostics systems MSPD, SMDO; application programming means MIS SM, KARS, SPO, TRAL, SPO MAGISTR, and DEMON; the programming language FORTRAN, COBOL, C, PASCAL, PL-1, BASIC, ADA, CORAL, BILSS-32, and MODULA-2. The basic data are:

- bit length of the data path is 32 bits;
- duration of the process cycle is 270 nsec;
- number of machine commands is 306;
- capacity of on-line memory is 2-4 MB;
- duration of the on-line memory cycle is 810 nsec;
- virtual address field is 4 GB;
- capacity of storage devices: on magnetic disks 28—276 MB, on magnetic tape up to 40 MB.

Electronic ES Family of Computers

The ES 1130 is an electronic general purpose computer, intended for use in local computer systems and networks, in territorial and cluster centers of computer centers.

It supports the solution of economic, scientific, engineering and special problems in autonomous mode and information processing systems in real time and time sharing modes.

The ES 1130 computer has sophisticated hardware control system, automatic restoration and automatic diagnostics. Malfunctions are localized with accuracy to 1-2 TEZ, and in on-line memory to the integrated circuit. It is program compatible with all computers of the unified system, which allows one to connect any devices of the ES computer family, which operate with standard input/output interface.

The computer software includes system, test and servicing panel software.

Basic data:

- productivity: for scientific and engineering problems, 2 million computations per second, for scheduling and economic problems 1.2 million computations per second;
- capacity of the on-line memory is 8 MB;
- number of input/output channels is 5;
- capacity of the input/output system is 9 MB;
- power consumption of the central section is 6 kV X A.

The 1068.17 ES is a stationary microprocessor computer based on the two-processor ES 1068 computer using ES 2706 type matrix processors. It is intended for building high power high capacity program and engineering complexes and networks of computers for different purposes with high throughput capability of the input/output system, large amount of external memory, which require high reliability.

Improvement of computer capacity is achieved by parallel operation of the computer process among central processors and matrix processors through a common field of the on-line memory. The presence of a common field of external memory ensures access of any central processor to any magnetic disk or magnetic tape storage device.

Special input/output interface switching devices allow one when necessary to connect all input/output devices and matrix processors to a single center processor.

Program support for the computer includes system, test and service software. The OS 7 ES operating system is built on the concept of virtual computers.

Basic data:

- capacity (for scientific and engineering problems) is up to 600 million computations per second;
- capacity of the on-line memory is up to 16 MB;
- number of input/output channels: unit-multiplexing 20, byte-multiplexing 4;
- capacity of external memory: magnetic disk up to 9.2 GB, magnetic tapes up to 4.5 GB.

The ES 1841 personal professional computer is a universal microcomputer system, intended for use:

- in autonomous mode for solving a large category of scientific, engineering and economic problems, problems of administration and business, and also for creating automatic regulating systems for various professional purposes based on it;

- in data remote processing systems and local computing systems to create information-retrieval systems, and management and business systems.

The ES 1842 personal computer. It is intended for use:

- in autonomous mode for solving a broad array of scientific, engineering and economic problems, problems of management and business, and also for creating automatic power regulators for various purposes based on it;
- in data remote processing systems and local computer networks for creating information-retrieval systems, management and business systems.

Functional capabilities:

- multiassignment operating mode based on emulation of the 18026 microprocessor;
- virtual organization of on-line memory;
- multiassignment operating mode in a medium of a large number of virtual 18086 type microprocessors;
- improved resolving capability of graphic information display equipment, 640 X 350 points;
- hardware implementation of a number of functions for constructing graphic images (multiplication, panoramic, perspective geometry construction).

Composition of the personal computer is oriented to its use in the area of professional work and includes:

- a set of peripheral devices;
- 4-register keyboards;
- graphics display;
- two floppy magnetic disk storage devices (NGMD);
- Winchester type magnetic disk storage (NMD);
- matrix printers;
- mouse type graphics information input device;
- large capacity on-line memory;
- floating decimal operation coprocessor;
- expansion equipment, which will ensure connection of additional boards.

The personal computer employs the principle of program exchange of code tables and character generators in the display and printer, which is the basis for using different alphabets and creating national versions of the system and application software, and it is highly reliable. It is simple to service and convenient to use. It combines high capacity, functional redundancy and completeness of embodiment.

The ES 1842 personal computer has sophisticated software, which is based on original programs, and also the possibility of running programs which have been written for other personal computers, which use the KM 1810 BM86 microprocessors (or 18086/18088) and 180286.

A set of test programs ensures a check of proper functioning and localization of malfunctions of the functional units and peripheral devices of the personal computer.

Operating systems, programming systems and application programs, which have been developed for personal computers of the IBM PC, IBM PC/XT and IBM PC/AT family of personal computers can function in this personal computer.

Basic data.

The processor (16-bit microprocessor K 1810BM86M):

—speed is 2×10^6 register—register type operations per second.

On-line memory:

—capacity is 512—2048 KB;

—directly addressable volume is 8 MB;

—virtual memory is up to 1 GM.

Number of keyboard keys (programmable ones of them) is 103 (12).

Microcomputers have been very well represented at the exhibit. Among them are the two-processor microcomputer Elektronika MS 0511, the single-board Elektronika MS 1201 microcomputer (its model MS 1201.04 has on-line memory up to 1 MB), the Iskra-1080 Tartu personal computer and others. A general description of the Soviet personal computers, which were presented at the exhibit, will be found by readers in the article by A. A. Stanishevskiy "Personal'nyye (EVM)" (Personal Computers).

Here we will briefly examine only two models.

The ISTR-4816 personal computer is the base model of a number of high capacity microprocessor personal computers which are being developed and planned for development, which are made with Soviet components. According to the classification adopted in the USSR the ISTR-4816 is a PM 4 category personal computer and is intended for automated text processing for publishing houses and newspaper editing rooms.

The ISTR-4816 has a unique three-processor architecture. The four-port RAM with volume from 1 to 4 MB is accessible to 4 users. Access to the RAM is regulated by a memory field arbiter. Three processors and a video terminal controller are available to the RAM users, and each of the users has access to the entire volume of the RAM.

The system processors do not have peripheral framework. The hardware-programming environment of the peripheral processor serves as the input/output environment and system processor interrupt. By signals and customized signals (I/OR, I/OW, I/NTA) the system processors influence the interrupt system of the peripheral processor.

These architectural features allow one to basically emulate any personal computer, including the IBM PC.

The operating system of the ISTR-4816 personal computer is compatible with MS DOS (version 3.20-3.30).

Specifications:

—number of general purpose microprocessors in a system board, 2;

—bit length of the general purpose microprocessors is 16/8 bits;

—number of specialized processors is 2;

—number of simultaneously operating operating systems is 2;

—type of operating systems include MS DOS; CP/M86; CP/M80;

—productivity index in base configuration is 7.2;

—maximal capacity of the RAM in base configuration of the personal computer is 4 MB on the systems board;

—RAM capacity: in base configuration of the personal computer 0.064 MB, maximal capacity 2 MB (due to expansion modules);

—maximal unformatted capacity of the floppy disk storage in base configuration of the computer is 3.2 MB;

—capacity, formatted by magnetic disk storage, is 10(20) MB;

—number of free spaces for installing custom dedicated modules is 4;

—speed is 4 million brief operations per second;

—number of integrated circuits, used in the base configuration, is 380.

The Elektronika BK0011 personal microcomputer. It is intended for use as a work station for a student, home personal computer, computing, information-retrieval, control and management device at enterprises and establishments, for the non-professional user.

Basic data:

—bit length of the processor is 16 bits;

—clock cycle is 3 MHz;

- time for executing register—registered type addition commands is 3.3 microseconds;
- memory organization is page;
- page size of the RAM, permanent memory is 16 KB;
- amount of RAM (page) is 128 (8 KB);
- screen memory RAM is 16-32 KB;
- rate of information handling: with tape recorder 1200 baud, in a local network 57,600 baud;
- power consumption (through the power supply unit) without external devices is not more than 50 volt-amperes.

CZECHOSLOVAKIAN SOCIALIST REPUBLIC

The Czechoslovakian Exhibit consisted of two relatively independent complexes. Thematically the exhibit was broken down into four parts.

1. Equipment and technology for manufacturing computer technology equipment, maintenance and component base.
2. Advanced computer technology equipment.
3. Problem-oriented complexes.
4. Computer equipment software.

The Czechoslovakian display at this international exhibit shows the country not only to be an important manufacturer of computers and computer technology, including external devices, but a producer of technological equipment and components.

At the exhibit one can see displays of many Czechoslovakian manufacturing, retail and servicing organizations. State enterprises, which are associated in the stock company ZAVT of Prague, are the largest Czechoslovakian display and also the largest producer of computer and automated equipment in Czechoslovakia.

A number of small computers of the SM family, including personal computers, systems of a number of ES computers and a broad array of external equipment are currently part of the developmental program of ZAVT, a stock company. The ZAVT manufacturing program also includes production of devices and equipment for monitoring and software control of machining equipment with NPC, industrial robots and manipulating devices.

Cooperation has been developed on a multilateral basis within the framework of the Inter-governmental Commission for Computer Technology and its operating departments. As an example one can cite the multi-year cooperation between the Kiev Institute of Cybernetics imeni Academician Glushkova of the Ukrainian SSR Academy of Sciences and the state enterprises Kantse-larzhsk stroy of Prague within the framework of the

CMEA Interface program, cooperation between the Scientific Research Institute of Mathematical Machines (Prague) and NITsEVT (Moscow) in the field of ES computer application program packages in cooperation with the Estonian SSR Academy of Sciences Institute of Cybernetics in developing complexes of software for automated production control systems. One might also mention cooperation in the field of the developing 32-bit computers between the Scientific Research Institute of Computer Technology in the city of Zhilina and the Moscow Ineum and in the field of prospective personal computers, which involve cooperation with the USSR Academy of Sciences Institute of Problems of Information Science.

The state enterprise ZVT Banska Bystritsa, known as an expert producer of SM computers, participated at the exhibit as part of the ZAVT display. Its systems 52/11 and 52/12 offer an important advance in computer technology within CMEA. The state enterprise ZVT Banska Bystritsa demonstrated the MTS 10 tester at the exhibit among other interface products, which was equipped with a temperature-regulator chamber.

The Institute of Technical Cybernetics of the Slovakian Academy of Sciences presented the Czechoslovakian Scientific Research Base at the exhibit. It demonstrated the PPS SIMD system, a particularly powerful associative system of computers for processing images, scientific calculations and large information systems. There was great interest in a processor with reduced instruction set RISC and set of application programs GRASYDEL PPC for designing the topography of integrated circuits.

The Czechoslovakian booth also included displays of the enterprises ZBROYIOVSK of Brno, TESLA-SE of Bratislava, Metra Blansko and others.

The SM 52/12 Computer System

The SM 52/12 system is a powerful 32-bit computer, the hardware and software of which are based on 16-bit computers with common bus. The on-line memory when using 256 K1 components has up to 64 MB for a single control device; when using 64 K1 components the maximum capacity is 16 MB for a single control device.

The system has a powerful set of instructions, which are intended for working with data with floating decimal, with a sequence of characters, with compacted decimal sequences. The system is equipped with flexible diagnostics, including microdiagnostics equipment.

The proposed areas of application are:

- automation of design and drafting work;
- as a block element in a network of computers;
- as the central computer in hierarchical information and control systems;
- for complex scientific engineering calculation.

The basic software of the SM 52/12 software is oriented to two operating systems VOS/SM and DEMOS 32.

The VOS/SM operating system is a multipurpose system which is based on a virtual memory device, which allows one to process data in real time mode, and also in time distribution mode. It supports interactive and package processing of assignments. Translating programs of the programming languages Pascal, Fortran, and C have been accessible before now. Now, within framework of the state assignment MER III-2, the system is supplemented with translating programs for the Prolog and Cobol languages.

Within the state assignment JZPVI the operating DEMOS 32 (UNIX type) has been developed, which is intended for the work of a user in the following fields: creation of software, developing text information, in information systems.

All these new pieces of equipment are being made available commercially gradually beginning in 1988 through 1990. Prerequisites for considerable improvement of functional capabilities of the SM 52/12 systems have been created since the beginning of the production of new external devices (in particular, the Winchester type disk memory devices), by improving of the technological level of production and increasing quality of the component.

ARITMA Coordinate Graph Plotters

The production of coordinate graph plotters at the commercial enterprise ARITMA of Prague began in 1985, specifically with the production of the Minigraf 0507. This small coordinate graph plotter is intended primarily for use in schools.

The most interesting, from the standpoint of application possibilities, is the graphic output device, the ARITMA 0512 color graph. The production of this graph plotter with 8 printing heads began in 1983. It can be connected to all computers which are equipped with the serial asynchronous interface CCITT-V24/V23 (RS-232-C). Drawing is done in a rectangular coordinate system. Movement of the printing head and paper in the direction of both axes is done by step motors with microprocessor control.

The graph plotter can operate in reverse mode, that is as a digital convertor, which senses coordinates, the digital conversion is based on tuning of the printer head (or optical crosshairs) for a specific point of the drawing, pickup of its coordinates and transmission to the control computer. In addition to coordinates, the Kolorgraf 0512 is able to transmit data on its own tradition to the control computer.

Special printers are produced in Czechoslovakia for the Kolorgraf 0512.

GS-3 Interactive Graphics Device

A very powerful multiprocessor graphic device GS-3, which is intended for integration with the largest engineering work automation systems, was developed at the Scientific Research Institute of Computer Technology of Zhilin based on 32-bit computers, the SM 52/12 and ES 1027. The GRM 1520-F color graphics scanning monitor was specially developed.

Communication with higher level computer (host computer). During operation it is possible for example, to adjust the transmission rate, transmission rate limits, transmission delay, anticipation delay transmission mode, down time, on-going translation mode and corresponding control characters of this mode, adjustment of stop bits, leading edge scale, line ending chain, messages and instructions, disregard of erase signs and certain additional special translation adjustments.

Work with colors. Instructions for work with colors allow one to use any of three colors. For example, the creation of a color background, shading of a gray tone, color mixture of the background and color chart. The color chart is a relatively complex mechanism which allows one to create any required color and method of coverage or mutual influence of colors. Data of the color chart can be placed in the memory of the device.

Segments. A segment is a set of graphic objects and their properties, with which the graphic device works as a single set. Instructions of the graphic device allow one to adjust the priority image of a segment, for example, in flickering mode, copying of a segment, creation of identification titles of segments and so forth. Segments can also be magnified, reduced, shaped into a chain, moved, and rotated.

Control of the keyboard and definition of a marker. Instructions of the graphic device allow one to close (lock) the entire keyboard or only a part of it, for assignment of the marker to certain keys and its execution.

Choice of modes. This group of instructions switches the device to the required modes.

Work with the image. These instructions perform different manipulations (erasing, restoration, selection, adjustment), work with a group of images and with windows. It is possible to determine from 1 to 64 different occupied places. Parts of the graphic image can be selected and magnified using the functions PAN and ZOOM. Keys with the same name correspond to these functions.

Work with points of an image. One of the valuable properties of the device is the possibility of performing operations with the point of an image, the smallest representative component on the kinescope. The coordinates of these points can be written on the disk, and new non-standard filling patterns and other operations can be created from them.

Work surfaces. There is one more valuable property of the device. This allows one to work with graphic information on individual graphic surfaces (determination of the corresponding color chart, and also the method of coverage or mutual influence of colors facilitates work with graphic information.

MTS 10 Tester, Produced by ZVT Banska Bystritsa

The MTS 10 tester is an outgrowth of the MTS 01 tester, which was very popular with users due to its reliability and simple maintenance.

MTS 10 tester is intended for static measurements and dynamic tests of functions of digital integrated circuits with standard, medium, large and very large scale integration (memory devices, microprocessors and their support circuits). It has been used primarily in organizations engaged in the development and production of digital integrated circuits. It is also suitable for producers of radio electronic equipment with large use of digital integrated circuits for acceptance inspection or even for grading based on selected parameters.

This system can be expanded by attachment of the KONSUL 2111 printer, punched tape reader, and tape punch.

For correct measurement and tests of each type of integrated circuit the following custom hardware and software are required in accordance with the needs of the user:

- two custom boards for the PIN electronics control unit;
- one standard board for output display of the tester;
- test program.

These devices are not included in the integral parts for MTS 10 deliveries and are delivered by agreement with the manufacturer.

The operating principle of the tester is relatively simple. Depending on the microprogram of the fast processor data are generated (from data processors and local memory) as well as addresses (from the address processors) for the integrated circuit being checked. The data and addresses are modified and shaped from the standpoint of the time sequence of signals. The output response from the inspected integrated circuit is compared with the expected values.

The result of comparison is analyzed by the control computer and displayed on the selected output device. For operation of the tester one requires the following software: basic operating system, operating system for tests, diagnostic program, program for developing programs for tests.

Further growth in the production of testers at ZVT is aimed at use of higher working frequency from 10 to 20 MHz and in the future up to 40 MHz. This increase of the operating frequency will make it possible to further expand the variety of measured and tested integrated circuits in the direction of higher scale integration.

COPYRIGHT: Izdatelstvo "Znaniye", 1989

Self Tuning Software Interface Orchestrating Microcomputer, Elektronika 8201 FODCS Interaction

UDC 681.3.013.4

907G0050A Yerevan IZVESTIYA NAUK
ARMYANSKOY SSR: SERIYA TEKHNICHESKIKH
NAUK in Russian
Vol 42 No 4, July-August 1989 pp 201-204

[Article under the "Brief Reports" rubric by G. A. Aleksanyan, G. L. Kantardzhyan, and A. M. Mirzoyan, AF IRYeA "Reakhrom"]

[Text] *The speed discrepancy between microcomputers and fiber optical data collection and distribution systems (FODCS) stands in the way of widespread practical introduction of the latter. A software interface that has been developed on the principle of self tuning prevents loss of information by synchronizing the starting times for channel scanning and determination of the optimal time delays. In practice, the setting of no less than two optimal values of the parameter for each random state of the FODCS output ensures high operating reliability of the software interface. One illustration, two references.*

In comparison with traditional devices such as analog-digital multichannel converters and digital-analog converters, FODCS (fiber optical data collection system) devices have a number of advantages, the chief of which include: reliability, noise immunity, multichannel communications over long distances (up to 1 km), and high speed of operation [1]. The main drawbacks of FODCS, standing in the way of their broad practical adoption, are the limited number of channels used (not more than 16) and the speed discrepancy between the FODCS and a microcomputer. While the number of channels in the FODCS device may be increased by hardware improvements, the speed discrepancy can be corrected by creating an appropriate software interface.

The present article develops a software interface that orchestrates the interaction between the FODCS and the microcomputer. Since the FODCS device maintains the channel value at its output for the duration of 5 μ s, while the most simple scan instruction for the microcomputer is executed in a time $\tau > 5 \mu$ s, consecutive channel scanning leads to a cyclical addressing of the same N channels ($N < 16$). Depending on the start of the scanning, in the best scenario the channels with either odd or even numbers are scanned. In order to eliminate this discrepancy, we must provide: a) synchronization of the start of the channel scanning; b) organization of appropriate time delays between the scanning of the individual channels.

In the software interface that has been developed, synchro pulses of the "Timer" block with period T_{syn} are used to synchronize the start of the channel scanning. Since the time to scan all channels of the FODCS device comprises T_{FODCS} and both devices work independently of each other, at intervals of $n = T_{syn}/T_{FODCS}$ cycles the

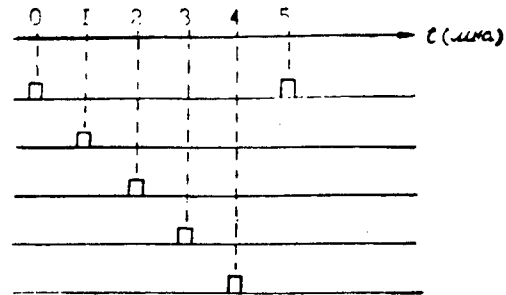

Random states of an arbitrary channel in the FODCS output.

presence of the synchro pulse will concur with the identical random state of the FODCS output. These random states of the FODCS output may be different in accordance with the sequence of activation of the FODCS and the "Timer" block, as well as the time delay. The time diagram for coincidence of the synchro pulses with the random states of an arbitrary channel with accuracy down to 1 μ s is shown in the figure.

The synchro pulses that are used may coincide with equal probability with one of five states of the FODCS output, yet it is not possible to determine the output state with which the synchro pulse coincides. In order to overcome this uncertainty, we add to the software interface a regulated parameter T_{IDj} , the initial delay before the first scanning. Analyzing the results of its operation, the program specifies the appropriate parameters to automatically change the value of T_{IDj} . Five parameters are provided ($j=1, \dots, 5$), and depending on the state with which the synchro pulse coincides T_{IDj} changes in accordance with the algorithm:

$$T_{IDji} = T_{IDj}' + t_i \quad (1)$$

where T_{IDj}' is the initial delay when the synchro pulse coincides with the zeroth state, $t_i = 1 \mu$ s, $i=0, 1, \dots, 4$ is the number of the state of an arbitrary channel at the FODCS output. Recurrence of the channel within one scan cycle is used as the condition for setting the parameter.

In addition to these delays (1), other time delays have been introduced into the program: $T_{D1} = 10.8 \mu$ s between the scanning of two different channels, $T_{D2} = 20.8 \mu$ s, $T_{D3} = 6 \mu$ s after scanning of four and eight different channels. The time for one scanning cycle is determined by formula:

$$T_c = 16T_{ins} + 12T_{D1} + 2T_{D2} + T_{D3} + T_{IDj} \quad (2)$$

where $T_{ins} = T_{sou} + T_{scan} + T_{rec}$ is the time to carry out the instruction of scanning a channel from the output of the FODCS, T_{sou} and T_{rec} are the times to determine the source and the receiver, T_{scan} is the time to perform the scan operation.

The process of self tuning of the interface program that implements (1) and (2) is complete when all 16 different channels are scanned during one scan cycle. Of course, it is necessary to ensure that:

$$T_c < T_{syn}, \quad (3)$$

which guarantees that the scan cycle is completed before the next synchro pulse appears. Otherwise, scan cycles will be lost, and the real time will not be accurately kept, since the common bus has no provision for resolving a conflict between two interrupts of equal priority.

This interface was implemented in the microcomputer Elektronika-60 M. The period of synchro pulses of the "Timer" block of this microcomputer is 2000 μ s, the time to perform the scan instruction of type $MOV \omega \#ADR, UST, (Rn)T_{ins}$ ($\omega \#ADR, UST$ is the address of the device of the parallel exchange interface I2, Rn is the address of the corresponding general-use register [2]) is 9.2 μ s, so that at intervals of $n = T_{syn} / T_{FODCS} = 25$ cycles the synchro pulses coincided with one of the five random states of the original channel. Further scanning resulted in cyclical addressing of the same channels, since $\tau = T_{ins} > 5 \mu$ s. In the course of the automatic self tuning of the program interface, the following approximately optimal values were obtained for the

parameter T_{IDji} : $i=0$ (synchro pulse coincides with zeroth state of FODCS output)— $T_{ID40} = 75.6 \mu$ s, $T_{ID50} = 89.6 \mu$ s,

$i=1$ — $T_{ID11} = 34.6 \mu$ s, $T_{ID12} = 48.6 \mu$ s, $T_{ID15} = 90.6 \mu$ s;
 $i=2$ — $T_{ID21} = 35.6 \mu$ s, $T_{ID22} = 49.6 \mu$ s, T_{ID13} [as printed] = 63.6 μ s; $i=3$ — $T_{ID31} = 36.6 \mu$ s, $T_{ID32} = 50.6 \mu$ s, $T_{ID33} = 64.6 \mu$ s; $T_{ID34} = 78.6 \mu$ s, $i=4$ — $T_{ID43} = 65.6 \mu$ s, T_{ID14} [as printed] = 79.6 μ s, $T_{ID45} = 93.6 \mu$ s.

The maximum value of T_c , corresponding to an approximate time delay of $T_{ID45} = 93.6 \mu$ s, is equal to 418 μ s and satisfies condition (3).

The presence of not less than two optimal values of the parameter T_{IDji} for each random state of the FODCS output ensures a reliable working of the program interface.

Bibliography

1. "Ustroystvo sbora analogovykh dannykh 'Elektronika MS 8201': Tekhnicheskoye opisaniye [The Elektronika MS 8201 analog data collection device: technical description]," Voronezh, 1984, 20 pp.
2. "Tsentralnyy protsessor M2. 'Elektronika 60 M': Tekhnicheskoye opisaniye i instruktsiya po ekspluatatsii 3.858.382 TO [The Elektronika 60 M central processor M2: technical description and operating instructions]," Voronezh, 1982, 120 pp.

Problems of Machine Translation

18630220 Moscow *NOVOYE V ZHIZNI, NAUKE, TEKHNIKE: VYCHISLITELNAYA TEKHNIKA I EYE PRIMENENIYE* in Russian No 7, 1 Jul 89 pp 3-17

[Article by O. S. Kulagina. First paragraph is introductory material.]

[Text] Frequently, computers are thought of as mathematical machines which were developed to do numerical calculations. Actually, computers are linguistic machines; their strength lies in the ability to manipulate linguistic symbols.

The Current State of Machine Translation

In their four decades of existence, computers have come into widespread and permanent use in various areas of human activity. They appeared as a means of speeding up calculations, but they quite rapidly turned into a means of processing information with much wider applications. One of the non-computational areas of application which emerged rather early on was the automatic processing of texts in natural languages (NL), primarily the translation of texts in one NL to another, machine translation (MT), or automatic translation (AT), which is the same thing.

The task of translation was chosen as the primary task of automated processing due to the demand for translations, on the one hand, and on the other, that there is a much clearer criterion for evaluating results in a translation than in the understanding of texts, dialogue, etc. The creation of systems which to some degree automate translation requires a large amount of work by linguists, mathematicians, and programmers. Not only must applications problems be solved, but also a number of serious theoretical problems in mathematics, cybernetics, linguistics, cognitiveology, programming, and other fields of knowledge. This situation has led to the emergence of a branch of science concerned with the construction of automated translation systems. As in the translation of texts from one NL to another, translation using computers is called "machine translation."

There are at present a number of computer-implemented translation systems in the world. Below we will name many of them. But before we turn to a discussion of specific systems, let us present their characteristics. Translation systems can be characterized, first, from the point of view of what they translate (that is, what is at the input), second, what they give as a result (that is, what is at the output), and third, by how their work process is organized, that is, how translation proceeds from the input to the output.

The languages and types of texts for which the system is designed are part of the characteristic of what is input into the system. There are bilingual and multilingual systems. The first systems were bilingual systems, and the translation went from the "foreign" language into the native language with the goal of obtaining information.

Later, bilingual systems for translation from the native language to the foreign language appeared, with the goal of disseminating information. Then multilingual systems began to be built with various combinations of languages. Frequently, the combination of one input language and several output languages is encountered, and less frequently, several input languages with a single output language, or a group of languages, with the capability of translating any language into any other language in the group.

As for the types of texts, it should be stated that, from the very beginning of work in the automation of translation, the range of translatable texts was limited: one always spoke of the translation of scientific and technical texts, and texts of a commercial nature (sometimes united in the term "commercial prose"). The question of translating artistic literature and even poetry was never raised. Up until recently one spoke only of the translation of written texts, and only in recent years has work begun on the translation of oral dialogue.

Most frequently, scientific and technical articles (sometimes only the headings or annotations) and patents are translated from the foreign language into the native language. A variety of technical documentation (instructions, directions, and so on) are translated from the native language into foreign languages, and these accompany exports of industrial products. The limits on the types of texts indicated above are frequently accompanied by limitations on the theme, that is on the subject matter. For example, there is a system for the translation of medical texts or metallurgical patents, etc.

Somewhat separate from these are systems designed for only a very specific type of input message, that is, systems with severe limits on the structure of the input. Such a system is the METEO system, which translates only the texts of weather reports.

Recently, a new trend has emerged in machine translation, the translation of dialogue between computer terminals or even oral dialogue by telephone. Here a whole new set of circumstances arises. At this time, only translation of conversations in a very narrow range of subjects is proposed in these systems: reservation of a hotel room, the route through a city, and so on. This type of theme is not examined in the translation of written texts. Statements in a dialogue have definite structural properties. Finally, in the translation of oral dialogue, the translation system should be linked with an analysis system and/or a speech synthesizer.

The requirements placed on the quality of the result, that is, the output, are determined by the method of translation. In general, it is always better to obtain a good translation. But, as the experience of the first practical systems has shown, when a translation is done with the goal of obtaining information, even a poor translation which has not been reworked by an editor may be useful to the user who knows the subject area but has no knowledge of the language and has no means of rapidly

and inexpensively obtaining the translation by other means. In this situation even a poor translation may be sufficient to judge whether a given text is useful to the person needing the information. A Russian reader can easily imagine such a situation by imagining that there are two texts in front of him: one in Japanese or Chinese in hieroglyphics, and the other in even somewhat twisted Russian.

The situation of translation into a foreign language, that is, with the goal of dissemination of information, usually requires a higher quality result, but here the situation is frequently facilitated by large limits on the input texts.

Speaking of the means of organizing the work of a translation system, let us examine, first of all, various cases of interactions between man and the translation system. We will clarify the various means of organization by schemes, for which we will introduce some notations. Tin is the input text to be translated; Tout is the output translated text; Tint is the intermediate text, the result of translation without editing, output by a human (TintH) or a machine (TintM). In the schemes, boldface text indicates work done by a human, italic, work done by a computer.

In "human" translation, frequently the text is processed by at least two people, the translator and the editor. The organization of work could be illustrated by scheme I.

I. Tin → **Translator** → TintH → **Editor** → Tout.

First it was assumed that the translation system would replace the translator, but the editor would remain. That is, scheme II was thought up.

II. Tin → **HI** → *Translation system* → TintM → **Editor** → Tout.

Here HI shows the work done by a human by inputting the text to be translated into the computer memory.

With the expansion of means of automating the introduction of editing corrections (IEC), known as text/word processing, scheme II underwent some changes, and scheme IIa emerged, in which a six-point scheme illustrates the work of the editor using IEC.

IIa. Tin → **HI** → *Translation system* → TintM → **Editor** + IEC → Tout.

Schemes II and IIa are work schemes with post-editing. Scheme IIa is in more widespread use today. In essence, today's use of translation systems with post-editing is efficient in terms of the expenditure and time and money (or, as we have already said, it is technologically efficient), not because translation systems have been constructed which could give a TintM comparable in quality to a TintH, but because of other factors. There are estimates that a translator spends 40 percent of his time looking for words in a dictionary, 40 percent typing the translation, and only 20 percent on the translation itself. There is no information about how an editor divides up

his time, but it is natural to assume that manual correction of translator errors and retyping takes some time. Since in scheme IIa the time to search in dictionaries and print the text is reduced, it follows that the work proceeds more quickly than in scheme I. On average, various translation bureaus have noted an increase in translator productivity by a factor of 2-3, and in some special cases, increases of up to a factor of 5.

In the translation of texts from the native language to the foreign language, another work scheme is useful, one with pre-editing, that is, a scheme where the editor works with the text before the system begins to translate it. Pre-editing may consist of the exclusion of constructions which are difficult to translate (for example, the exclusion of inversions, ellipsis, etc.) or the preliminary marking of the text (for example, marking simple sentences with parentheses and so on). The pre-editor also uses IEC, and so the scheme looks like this:

III. Tin → Pre-editor + IEC → TintH → *Translation system* → Tout

Here the work at the input is combined with the pre-editing.

Pre-editing does not exclude post-editing, so scheme IV is possible.

IV. Tin → Pre-editor + IEC → TintH → *Translation system* → TintM → Post-editor + IEC → Tout

The development of means of working interactively with the computer has led to new ways of organizing translation work. Humans were now able to interact with the translation system at the intermediate stages of the translation process, that is to say, inter-editing arose. Translation with inter-editing, where a human takes on the responsibility of resolving substantial problems, cannot be called machine translation in the full sense of the word. It should more correctly be called machine-human translation (MHT). It is represented by the following scheme:

V. Tin → **HI** → **MMT System** → TintMH → Post-editor + IEC → Tout.

Here the intermediate result TintMH is the result of work by a human and a machine.

Finally, another scheme is possible, human-machine translation (HMT), in which a human translates, and only reference to a dictionary is automated.

VI. Tin → **Translator** → TintH → **Editor** → Tout
Automated dictionary

When one speaks of the automation of translation, one usually has in mind translation using schemes II-VI. "Machine translation" in the strict sense of the word is translation using one of schemes II-IV (that is, without the intervention of humans in the intermediate stages);

but sometimes this term is used in a broad sense, encompassing machine translation in the strict sense as well as MHT and HMT.

In this survey, when we use the term translation systems we mean MT and MHT systems (that is schemes II-V). We do not examine HMT.

Let us turn now to an examination of how work is carried out within the translation system. Several types of translation systems are known.

When translation is done by a human, it obviously proceeds along the following general lines. Once he has translated a text fragment (a phrase, paragraph, etc.), he clarifies its sense to himself, then translates this sense into the output language, preserving not only its sense, but a definite structural closeness to the original (or else it is not a translation, but a paraphrase). He uses linguistic knowledge, that is knowledge about both languages in the translation, as well as extra-linguistic knowledge, that is, knowledge about the subject area, the general workings of the world around him, rules for communication, and so on.

How tempting it would be to reproduce this scheme into a translation system; however, this is as far beyond the capabilities of a computer as it is from the areas studied in linguistics and cogniology. Naturally, the construction of translation systems proceeds along lines of construction of which approximate this scheme.

Above all it should be noted that the overwhelming majority of translation systems translate individual phrases; the connections beyond the limits of phrases are analyzed only in rare cases.

The first machine translation systems made the transition from the input language to the output language on a level very close to the surface level, and very far from its sense. These systems were called first-generation systems or direct systems. We will call them D-systems.

Translation in a D-system proceeds as follows. First, the phrase to be translated is transformed into its morphological representation. In it, each textual unit, the word, punctuation mark, or locution (combination of words which should be translated as a unit, and not word-for-word) is replaced by a set of symbols (more accurately, a symbol-meaning pair). For this, a dictionary of word roots is used, in which each root is supplied with a set of symbols, a dictionary of locutions, a stored list of locutions with their symbols, and morphological analysis (MA), providing information on the form of the words (number, case, tense, aspect, and so on).

Then the morphological representation of the input phrase is transformed into the morphological representation of the output phrase. By analyzing the form of the word and its linear context, information is established about the form and location of the translated word.

Knowledge of both languages is used. The analysis of the input phrase is done immediately with orientation in the output language.

The final stage, morphological synthesis (MSyn), is where, based on data written in the morphological representation of the output phrase, the translated words are given their required form and placed in the required order.

Since the MA and MSyn stages are relatively simple, in essence, this approach almost reduces translation to the stage of transforming one morphological representation into another. On the whole, the described scheme is close to obtaining a word-for-word translation.

D-systems were built in the 50s, but are still sometimes built today. The experience of work with D-systems is the basis for the construction of more complex systems.

In T-systems (T for transfer, meaning the transfer from one language to another) the sequence of work stages is as follows. After MA comes syntactic analysis of the input phrase (SA), building its syntactic representation in the form of a syntactic tree.

After syntactic analysis follows the transfer stage from one language to the other, in which the syntactic tree of the input phrase is transformed into the syntactic tree of the output phrase.

It should be stated that different T-systems use different representations of the transfer level: surface-syntactic, deep-syntactic, syntactic-semantic. Consequently, the transfer level may be somewhat nearer to the surface text level or further from it. But we cannot examine these fine points here.

The syntactic representation of the output phrase obtained as a result of the transfer is the raw material for syntactic synthesis (SSyn), in which the morphological representation of the output phrase is worked out (that is, information is established on the form of the words and their order). MSyn is the same in D-systems and T-systems.

T-systems are also called second-generation systems, and they are now in widespread use. It should be noted that in the transition from first-generation systems to second-generation systems there was not only a separation of syntactic analysis from syntactic synthesis, but also a separation of "grammar from mechanism" (as formulated by V. Ingve). In first-generation systems, grammatical rules were usually formulated as instructions on the production of some action. In second-generation systems, grammatical rules obtained declarative (descriptive) forms, and algorithms for their use were formulated separately.

The third interesting type of translation system is the third-generation system or I-systems (interlingual). They can be thought of as systems in which the analysis results in a representation independent of the input and output languages (interlingual). This requires knowledge of

semantics, pragmatics, and extra-linguistic knowledge. People don't yet know how to work with this entire body of knowledge (they don't know how to put it in the form of work rules for a translation system). Thus, in these interlingual systems, the syntactic analysis stage is followed by a semantic analysis stage, which, in the best case, uses some information on the subject area. As a result, a semantic representation is obtained which is recognized as identical for the input and output phrase from accuracy to vocabulary. Semantic synthesis is turned into syntactic representation, and further synthesis occurs as in T-systems.

To build a translation system is to develop different types of support: linguistic, mathematical-algorithmic, program, information, and logical. The first three types are present in all systems, while the latter two are more rare.

Let us explain what is included in these types of support.

Linguistic support includes dictionaries of words and phrases with their symbols, tables of suffixes and endings needed for morphological analysis and synthesis, grammatical rules, and data tables for the remaining stages of work.

Mathematical-algorithmic support include formalisms for the representation of linguistic and processed data and algorithms to define the operation of rules at each stage.

Program support consists of the programs which implement the translation process, as well as service programs (to support the dictionaries, introduce changes in the rules, etc.).

Information support is the body of extra-linguistic knowledge about the subject areas.

Logical support is the set of rules of logical deduction with which the extra-linguistic knowledge is applied to refine the representations of the processed text.

The development of the types of support listed above would be impossible without conducting numerous translation experiments. Thus, work begins with the creation of an experimental system containing a basic set of rules which are amplified and improved based on the results obtained during the translation experiments. As a rule, this requires several years of work.

If the system has research goals, then it may remain experimental. If the work is done with the goal of obtaining a practical working system, then once it is tested in experiments it becomes a prototype to be copied. Changes may be made to the software and the dictionaries to accommodate the needs of the user. Commercial systems (that is, those made available for sale) usually have more developed software, especially the service programs.

A system for practical use usually has one of the organization schemes indicated above. It is true that sometimes, to make do without editors, the result output by the system, which has not been reworked, goes directly to the user, a specialist in the subject field, to whom it is sufficient to get an idea of the content of the text and a polished translation is unnecessary.

The History of the Development of Automated Translation Work

Let us talk very briefly about the history of the development of work on the automation of translation. We have already mentioned that the problem of translation with a computer was formulated very early: the idea was suggested in 1946. In 1952 in the US, the first project for translation work emerged, which led to the famous 1954 Georgetown machine translation experiment. This was the first public experiment in computer translation. It created interest in many fields, and quickly work on the automation of translation began in England, Bulgaria, Italy, China, France, East and West Germany, Japan, and the USSR. By the mid 60s the first two practical working direct systems appeared in the US. Both translated from Russian to English.

The period of the first rise ended with the appearance of the conclusions of the infamous ALPAC commission in the US. This commission, which evaluated the results of systems created up until that time, felt that machine translation was unprofitable for conditions in the US. Although the commission recommended further theoretical investigations in this field, its conclusions were taken as extremely pessimistic in various countries, and this led to a sharp decline in interest in the problem of machine translation, decreased funding, and in some places, cessation of the work.

The period of the decline in interest continued for about ten years; however, the work never fully stopped. New types of systems appeared. Moreover, the rebirth of machine translation was aided by a number of factors outside this field, on the one hand, the active increase in the need for translations, due to the expansion of cultural and economic cooperation of various countries, and on the other, the rapid growth of computing capabilities. More and more, computers were seen as more than a means of calculation. Work was begun on the creation of information search systems, terminological banks, and so on. The appearance of personal computers changed many people's relation with computers, and this affected machine translation.

All this led to the beginning of a new rise in the field of machine translation in the mid 70s. A whole new set of working and commercial systems appeared. The 80s became the transition period to widespread use of translation systems in many countries, and the market for commercial systems expanded. Special conferences were devoted to the discussion of experience in using these systems. As we have already said, not one of the translation systems yielded a high quality translation for a

wide range of texts. However, even the existing systems could be effective when placed in the right spot in the technological chain (see the organization schemes above).

Foreign Translation Systems

Today's balance of power differs from the balance of power during the first rise. The initial work on machine translation was done in the US, and today's leader is Japan.

The need for translations in Japan, due to the specifics of the Japanese language, differs from the need for translations in the US. Japan makes huge expenditures for translations, and the government considers machine translation as a vital need for the country. In Japan, more than anywhere else, work not only on the construction of working systems, but also research in the field of machine translation is financed. In his survey, W. Hutchins [9] estimates that the total number of specialists in the field of machine translation in Japan is 800-900, which is about equal to the number of machine translation specialists in all the remaining countries. Of this number, up to 60 percent of the specialists are working for companies.

In the majority of cases, systems are developed for the translation of a pair of languages: Japanese and English in one or both directions. The largest development is a Japanese government project, known as the mu-project, financed by special coordinated funds for the development of science and technology from the Agency for Science and Technology. Its goal is the creation of two systems: for translation from Japanese to English, and for the translation from English to Japanese. Both are intended for the translation of the abstracts of scientific articles, in particular, those in the journal "Bibliography of Science and Technology" which is published by the Japanese Information Center for Science and Technology. Four organizations are participating in the mu-project. The group of the university of Kyoto, under the direction of Professor M. Nagao, is responsible for the general structure of the system, grammar, and mathematical support. The remaining groups are responsible for the dictionaries and the interface. This project has two parts. The first (1982-1986) led to the creation of a prototype system. The second (1986-1990) should result in a practical system. In the second part, the key role is being played not by the University of Kyoto, but by the Japanese Information Center on Science and Technology.

Both systems of the mu-project are T-systems. The transfer from language to language occurs at the deep-syntactic structure level. The representation of the translated phrase at this level has the form of a relation tree, the branches of which correspond to the deep cases ("subject, object, instrument, cause" etc.), that is, the syntactic-semantic roles of the predicate arguments. In the system, the transfer stage is carefully developed, due to the substantial differences in the Japanese and English

languages. In particular, the fact that the Japanese language is a BE-language (the subject is a participant in the situation in which something occurs) and English is a DO-language (the subject is the main actor in the situation) leads to the contrast in phrase structure. For example, the same situation can be described in English by "Lightning burned the tree" and in Japanese by "The tree was burned by lightning." At the end of the first stage of the mu-project, the dictionaries contained 80,000 units each. The special language GRADE was developed to write the grammatical rules. The rule interpreter was written in LIST on a Facom 380 machine.

In addition to the University of Kyoto, the following groups are working on the machine translation of texts: the University of Tokyo, the prefectures of Osaka, Kiushi, Kobe, Oita, Fukuoka, and others. In addition to the Japanese-English pair, another fairly common pair is Japanese-Korean.

The first Japanese commercial system, ATLAS/I, was made by the Fudzitsu company. It went on the market in 1984, and by 1986 it had been installed in 70 organizations. ATLAS/I is a D-system for translation from English to Japanese. It works on the machines of the Fudzitsu company (model M340 and more powerful models) in conjunction with an S3000 microcomputer.

The Fudzitsu company placed the ATLAS/II system on the market in the middle of 1985, and three months after its appearance on the market it was acquired by 30 organizations. The ATLAS/II system is a T-system. It was initially intended for Japanese-English translation, but began to be thought of as a multilingual system for translation from Japanese to English, German and French, and from English to Japanese, German, and French. The Japanese-English version is on sale, and the others are being developed.

The Fudzitsu company is cooperating with Stuttgart University (West Germany) and with the Korean Higher Institute of Science and Technology (in the creation of a Japanese-Korean translation system).

In 1986, the T-system PENSEE appeared on the market. It was built by the Oki Computer Corporation. It is implemented in the C language on a microcomputer, and is intended for Japanese-English translation. It has a pre- and post-editor. The English-Japanese version is being developed.

In 1986, the PIVOT system from Nippon Electrical Company appeared on the market. This system is for Japanese-English translation in both directions. It has a 40,000 unit dictionary for Japanese, and a 53,000 unit dictionary for English. It differs from other translation systems in that it was planned as an interlingual system, and the transfer representation has the form of a network which expresses semantic and pragmatic information. It is implemented in the C language on an ACOS System 4 microcomputer. It has pre- and post- editing.

In 1987, the HICATS/JE system was put on the market by the Hitachi company. It has a 250,000 unit dictionary and is intended for Japanese-English translation. It is implemented in PL/1 on Hitachi computers. The English-Japanese version of HICATS/JE is being developed by Hitachi.

Also in 1987, the Japanese-English translation systems of the Sanyo and Mitsubishi companies appeared on the market. In 1988, Sharp and Ricoh plan to place their systems on the market.

Many other companies are working on machine translation. Some of them are building systems which are not intended for sale. For example in 1982 the IBM Corporation developed a system to translate instructions for IBM computers from English to Japanese. The system was designed for internal use.

Of the research work that is being done, the LUTE system of Nippon Telegraph and Telephone should be noted. Based on linguistic and extra-linguistic knowledge, they have proposed to build some representation of the sense not only of individual phrases, but the sense of the text as a whole. The representation would have the form of a hierarchy of frames. An experimental system was built in 1986 for Japanese-English translation, with dictionaries containing 3,000 units each.

Recently, Japan has been doing active work on the translation of dialogue. Above, we spoke briefly of the differences between translating dialogue and texts. Work on the automation of dialogue translation is being done at the University of Kyoto. In 1987, Toshiba demonstrated the capabilities of two of their systems (for English-Japanese and Japanese-English translation) by translating a dialogue in real time in a communications session via satellite between the laboratories of the firm and the visitors at the Telecom-87 International Exposition in Geneva. The operator in Geneva entered the message on the terminal in English, and it was transmitted to Japan, where it was translated by the system. The Japanese operator looked at the Japanese translation on his display, answered in Japanese, his message was translated by the system, and transmitted to Geneva. Of Toshiba's two systems, the English-Japanese translation system was placed on the market in 1987 under the name AS-TRANSAC. It works on AS3000 computers.

In Osaka at the ATR Interpreting Telephony Research Laboratories, there is a project (to last 15 years) for the translation of oral dialogue via telephone. The system includes subsystems to recognize speech, translate, and synthesize speech.

It is well known that speech recognition systems have an accuracy far from 100 percent. They are especially poor at recognizing short connective words. Thus the developers of the translation subsystems have constructed a grammar which makes it possible to build the correct

phrase from recognized significant words. The connective words of this phrase are checked against hypotheses given by the speech recognition system.

We have mentioned only a few of the Japanese universities and firms working on the automation of translation, but the information above gives the reader an idea of the scope of the work being done.

NEC and several other companies are also beginning work on the automation of translation of oral dialogue.

In 1987 the Japanese government began to fund a comprehensive project of the ODA (Overseas Development Agency). It is a six-year research and development project. In addition to Japan, other participants are China, Indonesia, Malaysia, and Thailand. The goal of the project is the construction of an interlingual multilingual system which can translate a group of languages: Japanese, Chinese, Indonesian, Malay, and Thai. Primary work will be done on versions in which one of the languages is Japanese. A total of 200 researchers from ten different centers are participating in the project. The main purpose of the ODA project is the development of trade and cultural links between Japan and other Asian nations, in particular, in the field of computer technology.

Let us briefly characterize work on machine translation in other Asian nations.

China's work began in the 50s, was interrupted during the period of decline, and renewed in the mid 70s. The main organization in translation work is the Language Engineering Laboratory (LEL) of the China Software Technique Corporation (CSTC). It is responsible for machine translation projects introduced in the seventh Five-Year Plan (1986-1990). Of these the main projects are for English-Chinese, and Japanese-Chinese translation. This organization is also responsible for cooperation with the ODA project. In 1987 LEL placed the TRANSTAR system on the market. It is used in translation bureaus. This is a T-system for English-Chinese translation with dictionaries containing 40,000 units of the general lexicon and 40,000 terms. It is implemented in COBOL on an IBM AT, and has been designed for post-editing.

Work on machine translation is also being done at the Institute for Linguistic Research of the China Academy of Social Sciences, the China Institute of Scientific and Technical Information, the Institute of Computing Technology, the Institute of Mathematical Techniques, the Universities of Nanking and Shanghai, as well as a number of other organizations.

South Korea is fairly active in machine translation. Many systems are being made for Korean-Japanese translation, frequently in cooperation with Japanese organizations.

In Malaysia, work on machine translation has been going on for about ten years in cooperation with the GETA

group of Grenoble University (France). In 1986, an experimental system for English-Malay translation for middle-school students was created. The University of Bangkok (Thailand) is working with the University of Malaysia and the GETA group.

In Hong Kong at the Chinese University, a system of machine-human translation, CULT, has been created for translation from Chinese to English. It has been used since 1975 to translate *Acta Mathematica Sinica* into English, and since 1976 to translate *Acta Physica Sinica* into English.

Now, let's talk about the work going on in Europe.

It is here, naturally, where the largest project, not only in Europe, but in the world, is going on, uniting the forces of specialists from 16 cities in Belgium, Great Britain, Greece, Denmark, Ireland, Italy, Luxembourg, the Netherlands, France, and West Germany. Moreover, there is a central group and secretariat in Geneva. The project is called EUROTRA and its goal is to obtain translations from any language to any language in the group of languages of the countries of the European Economic Community, including English, Dutch, Greek, Danish, Italian, German, and French. The issue of Spanish and Portuguese has not yet been resolved. Until the introduction of automation, more than 1800 translators were occupied with the translation of EEC documentation. At present, the SYSTRAN system is being used for these translations. This system will be discussed below.

Work on the EUROTRA project began in 1978. First it was planned that the prototype system would be ready in 1988, then in 1990, and a practical working system in 1993. The entire system would be a transfer system. The representation of data at the transfer stage would be the same regardless of the input and output languages, in order to make it possible to transfer from any language to any other. The research groups of various countries are to conduct analysis and synthesis of their own languages, so they are free to choose methods within the framework of some overall scheme. This overall scheme suggests that the system should be a multi-level system. The following levels are examined: the text level in natural language, the morphological level, the component level, the level of syntactic categories and relations, and the level of semantic categories and relations, that is, the deep cases. Each group will make their own transfers from level to level. A very general form of mathematical support is being created which should make it possible to choose very different strategies for a transfer from one level to another.

It is very difficult to achieve this goal. In 1987, a small prototype was ready which worked very slowly. However, it was decided to continue the work, although there is a danger that even the revised time limits will not be met.

In France, the most active work is being conducted by Grenoble University (the GETA group). Work was begun in 1961. This group created two experimental

Russian-French translation systems. The first was a D-system, the second, an I-system. This group's work is described in the monograph of Professor B. Vauquois, who has been the director of GETA for many years [13].

The GETA group has repeatedly advanced new ideas and solutions in the field of machine translation. The GETA group pays much attention to the mathematical-algorithmic support of machine translation systems. They have built powerful and flexible mathematical and algorithmic support systems for various types of transformations for processed data emerging in the course of machine translation: ATEF, ROBRA, TRANSF, and SYGMOR. They have also created the ARIANE dialogue system, which provides for the development of a translation system. In the dialogue process ARIANE makes it possible to describe a system of symbols used in dictionaries and grammatical rules of various stages, to start up the translation system as a whole or individual stages, and so on. At the beginning, ARIANE was implemented on large computers, later it was transported to the IBM PS.

Recently, the GETA group has begun work on machine-human translation. They have developed, in particular, means of removing ambiguities in translation from the native to the foreign language by paraphrasing.

Work on machine translation is also being done in Paris, Nancy, and Poitiers.

There is a large machine translation group in Saarbrücken in West Germany. Work began there in 1957. They have created a multilingual T-system, SUSY, with input languages (English, German, Russian, French, and Esperanto) and output languages (English, German, and French). The system is used in the University of the Saar, but has not been placed on the market.

There have been proposals to use the developments made for SUSY in the MRIS project to create a multilingual information-search system, which would provide for the creation of a partially-automated translation system.

West Germany is working with Japan on several projects on German-Japanese translation. In addition to the aforementioned pair, Fudzitsu and Stuttgart University, the Universities of Kyoto and the Saar were working together to build a system to translate the headings of scientific articles from German to Japanese.

There are groups participating in the EUROTRA project in Saarbrücken, Berlin, Bielefeld, and Stuttgart.

West Germany has huge terminological banks at its disposal: the TEAM bank of the Siemens company, and the bank of the Federal Translation Bureau. Work is being conducted to connect translation systems with them, in particular the TEAM bank and the METAL system.

In Great Britain at Manchester University, two interesting translation systems are being developed. They are

intended for English-speaking users who do not know Japanese to be able to translate Japanese into English and English into Japanese.

The system for English-Japanese translation is an interactive T-system which can ask the user what he had in mind in cases of syntactic homonymy.

In 1984 British Telecom began work on oral telephone conversation translation. The languages are English, Spanish, German, French, and Swedish. Work is based on a 1000 word dictionary on business conversations. It is expected that the system will be completed in the mid 90s.

In the Netherlands, two multilingual translation systems are being developed (intended to be I-systems). They are the Rosetta system of Philips and the DLT system of Buro vooz Systeemontwikkeling. The latter is interesting in that, in contrast to all other translation systems, it proposes the use of Esperanto as an intermediary language.

It is impossible to name all the groups working in various countries in Europe, so we limit ourselves to a list of the most well-known. In Italy, the University of Pisa; in Sweden, the University of Stockholm; in Norway, the University of Bergen; in Finland, the University of Helsinki; in Denmark, the University of Copenhagen; in Belgium, the Universities of Brussels, Leuze, and Leuven; in Spain, a division of the Siemens company in Barcelona, and the IBM Research Center; in Switzerland, the Institute of Semantic and Cognitive Studies. As indicated earlier, Greece, Ireland, and Luxembourg are among the countries participating in the EUROTRA project. There is also the research group of Karlov University in Prague (Czechoslovakia), the Central Linguistic Institute of the East German Academy of Sciences, Budapest University and the Hungarian Academy of Sciences, the Institute of Industrial Cybernetics and Robotization in Sofia (Bulgaria), and the Zheshuv (Poland) Polytechnical Institute.

This list is far from complete, but it gives the reader an idea of the scope of the work.

Let us turn now to work on machine translation on the American continent.

In Canada, translation work is concentrated on English and French, the official languages of the country. Work is being done at the Universities of Montreal, Toronto, Ottawa, and in various companies.

In 1977, the METEO translation system went into practical use. It is in operation at the Translation Bureau of the Ministry of the Environment. The system translates from English to French the texts of weather reports originating at various points (up to 5,000 messages daily). This system was intended only for a given form of text and has a rather strict grammar. All phrases which are incorrect from the point of view of this grammar are given to a human to be translated (about one tenth of the

total number). Correct formulations are translated by the system, and the translation goes to the user without editing (a rarity for machine translation).

At present the Montreal University group is working on the CRITTER system for English-French translation in both directions of weekly readings from the Ministry of Agriculture on the state of the agricultural product market.

Human-machine translation systems are also being developed in Canada, for example, the XTL system of the Societe canadienne de Traduction.

In South America there are two projects to create multilingual systems.

One of these projects, CADA (Computer Assisted Dialect Adaptation), began in 1979, and encompasses the languages of Brazil, Colombia, Ecuador, the Philippines, Peru, and Guatemala, and is based on the closeness of these languages.

The other project, ATAMIORI, was proposed in Bolivia. It is an interactive multilingual system for translation for groups of languages: English, Spanish, and German. The intermediary language is one of the Indian languages of South America, Aymara, which the creators of the system feel is appropriate for this role due to its regularity. It is being used at the Translation Center in Panama.

Let us now characterize the state of affairs in the US.

At the beginning of the article we noted that the first practical working machine translation systems appeared in the US. These were D-systems for Russian-English translation. One of them, the GAT system, was developed at Georgetown University, and began to be used in 1964 at the US Atomic Energy Commission and the Euratom Information Center in Ispra (Italy). Another is the MARK II system which was developed at the US Air Force Bureau of Foreign Technology. Later both of these systems were replaced by the SYSTRAN system.

SYSTRAN is the most widely used system in the world. It is based on GAT, and is also a D-system. Its first version was made for Russian-English translation, and had dictionaries containing 200,000 words of the general lexicon and over 200,000 terms. Gradually, versions were developed for 15 language pairs: from English to Dutch, Spanish, Italian, German, Portuguese, Russian, French, and Japanese; from French to English, Dutch, German; and from Spanish, German, Russian and Japanese into English. Other pairs are being developed.

In the US Air Force SYSTRAN replaced MARK II in 1970. In the late 80s it is used to translate up to 100,000 pages from Russian to English per year: Soviet patents and technical journals, basically on aviation and space. Various organizations in various countries use versions of SYSTRAN for some language pairs: XEROX in the US, General Motors in Canada, Aerospatiale in France,

NATO headquarters in Brussels, German Railroad Control, and the Research Atomic Center in Karlsruhe, West Germany, the Gachot translation bureaus in Paris, the European Center for Automatic Translation in Luxembourg, CSATA in Italy, etc. In France, SYSTRAN is linked through a network of Minitel computers to 4.5 million users, who use the system for business correspondence.

At present SYSTRAN is almost totally the property of the A. S. Gachot Company, who united the interests of all companies who owned SYSTRAN earlier in the US and Europe. Only SYSTRAN Corporation of Japan remains beyond its reach. The Iona Company (Japan) owns the SYSTRAN Corporation of Japan. Gachot is trying to provide uniform versions for various language pairs.

Two translation systems are in operation at the Pan-American Health Organization in Washington. SPANAM is a D-system for Spanish-English translation, and began operation in 1980. The ENGSPAN system for English-Spanish translation began operation in 1985, and it is a T-system which translates medical documentation. The dictionaries (about 50,000 units) contain medical terms, some very long, up to 25 words long.

Work on the LOGOS system began in 1964. In 1971-1973 it was used to translate military instructions from English to Vietnamese. Since 1978, work has been financed by Siemens (West Germany). German-English and English-German versions have been made which are being bought by companies in West Germany (Nixdorf, Hewlett-Packard).

The most complex commercial system is the METAL system, which was developed at Texas University (sold under the name LITRAS). It was developed for English-German translation in both directions but with a multilingual orientation. The grammars for Dutch, Spanish, and French are being developed. It is a T-system which provides pre- and post-editing. It is implemented on a Symbolics LISP machine, and editing is done on a PC.

In addition to machine translation systems, human-machine translation systems are also being sold and widely used. These are systems with inter-editing (interactive systems).

The leading producer of interactive systems for mini-computers is WCC (World Communication Center) which was earlier called Weidner Communications Corporation. Since 1988, WCC has belonged to the Bravis Japanese translation bureau. There are two versions of the WCC interactive systems: Macro-CAT on the DEC Vax II and Micro-CAT on the IBM PC XT or AT. There are versions for translation from English to Spanish, Italian, German, Portuguese, French, and Japanese, and from Spanish, French and Japanese into English. The first versions were D-systems, but now more complex systems are beginning to be built.

These systems have been sold since 1980. In 1980 for 130,000 pounds Weidner supplied a Digital computer with four terminals, software for the translation system and for the editing system, and a dictionary with 10,000 dictionary articles. The linguistic support for additional pairs of languages cost 75,000 pounds. The Japanese-English version is being actively sold in Japan. By 1988 the company had sold 3000 sets.

Another widely known company which sells interactive systems is the ALPS company, which sells three program packages for the IBM PC XT. Transactive provides interactive translation from English to Spanish, Italian, German, and French, and from French to English. Autoterm searches for terms in dictionaries. Translation support system is a processor for lexicographic works, calculation of word frequency, and the compilation of concordances. ALPS also sells other programs for work with texts.

There are other well known but less widespread MHT systems.

As for research in the US, it is basically being done in universities, at Carnegie-Mellon, Yale, Colgate, Georgetown, Texas, New Mexico, California, British Columbia, and others. The Carnegie-Mellon project should be noted. Translation systems are being created in which not only linguistic, but extra-linguistic knowledge is proposed for use.

The transition to widespread practical use of translation systems has forced us to reevaluate the interaction of human and machine in the translation process. The question has arisen how to keep a human editing the work of a system from becoming irritated by the need to correct many, and sometimes stupid, errors.

A. Melbi has suggested an automated translator workstation with three different levels of machine participation in the translation. The workstation is based on a personal computer. The first level is the simplest, automated search in dictionaries and the introduction of editing corrections. In the second level, the system can carry out certain text operations (provide examples of the use of an expression in different contexts, and so on). The third level includes an interactive translation system. The most basic feature is that a human can easily and simply move from one level to another. Then the translator can at will correct the result given by the system, translate it himself, or move to a lower level. The workstation is being developed in the US, Japan, and other countries.

Domestic machine translation systems

Work on machine translation began in the Soviet Union in 1954. At first they developed very actively, and working groups arose in Moscow, Leningrad, Yerevan, Tbilisi, Kiev, and later in other cities. They worked on a high theoretical plane, but, unfortunately, in the majority of cases without a sufficient machine base. Consequently, the majority of developments were not

sufficiently verified in translation experiments. Nonetheless, in the 50s and early 60s a number of D-systems were built, and in the late 60s, the first T-systems appeared: an English-Russian translation system at Leningrad University, and a French-Russian translation system, FR-II, developed at the Institute of Applied Mathematics of the USSR Academy of Sciences.

The FR-II system, in contrast to other experimental systems, underwent basic testing in experiments on texts. In this system the transfer from language to language occurred at the syntactic structure level, and had the form of a relation tree. The construction of syntactic structures was done by the filter method. The idea for this method was proposed by I. Leserf, and a computer implemented algorithm was developed for the FR-II. Filters are the limits on correct syntactic structure. The filters were used cyclically in the FR-II system, and they were applied to a set of hypothetical syntactic links before its separation into individual trees. The number of cycles was automatically regulated by the degree of complexity of the phrase to be analyzed.

As a result, a similar approach was used in the ETAP systems created at Informelektro [Information Center for Electronics].

A survey of Soviet systems of the 50s-70s and a detailed description of the FP-II system is contained in Reference 1.

The transition to practical implementation of machine translation in the Soviet Union occurred in the following manner. In 1973, a machine translation section was created at the All-Union Center for Translations of Scientific and Technical Literature and Documentation of the State ;Commission of the USSR Soviet of Ministers on Science and Technology and USSR Academy of Sciences (All-Union Translations Center). This section was charged with the development of practical systems. Despite the theoretical and experimental undertakings at that time, the All-Union Translations Center chose a D-system for practical implementation, the AMPAR system for English-Russian translation. The All-Union Translations Center built the same type of system for German-Russian translation, called NERPA. Later these two systems were combined in the ANRAP system (English-German-Russian Automated Translation), which works on a YeS 1035 computer. The results of the work of ANRAP are edited by translators at the All-Union Translations Center. There is no information yet on the Center's transition to a T-system.

Several organizations have reported the creation of word-for-word and word-for-word, locution-for-locution translation systems (simplified varieties of D-systems). In all cases, the translation is into Russian, and the input languages and subject matter are varied. At Informelektro (Moscow) headings of articles on electro-technology are translated from English and French; at the Herten Pedagogical Center (Leningrad) political texts are translated from English and French; at the

All-Union Scientific and Technical Research Institute for Electronics (Kharkov) texts on powder metallurgy are translated from English; at the Chimkent Pedagogical Institute texts on computers are translated from English. For as well-known as they are, all these systems have small dictionaries (from 5,000 to 20,000 entries) and are used in the organizations where they were developed. Some have not left the experimental stage.

The All-Union Translations Center is working on the creation of an automated translator workstation, a system of three basic subsystems: a subsystem to input text, search in the dictionaries, and edit the translation; a subsystem to support the dictionaries; and a subsystem to create personal glossaries of new terms. Of the most promising developments at the All-Union Translations Center we note the construction of a metasystem for machine translation, FLOREAT, and the development of a system for Japanese-Russian translation which was created in conjunction with the Institute of Oriental Studies of the USSR Academy of Sciences.

Research collectives (the Institute of Applied Mathematics of the USSR Academy of Sciences, Leningrad State University, etc.), which constructed experimental T-systems, have now moved away from translation subject matter.

It seems that the data presented here is sufficient to show that work on the automation of translation has a broad scope and continues to develop. There is no sense in arguing whether machines can translate. Machines have become active aids to humans in translation, but they have not replaced humans, as the pioneers of work on machine translation imagined.

A more detailed survey of work in machine translation can be found in Reference 2.

This survey is based on a large number of articles and conference reports. We will not list all of them, but indicate instead collections, the proceedings of conferences, and several monographs.

REFERENCES

1. Kulagina, O. S. "Issledovaniya no mashinnomu perevody" [Research on Machine Translation]. Moscow: Nauka 1979 320 pp.
2. Kulagina, O. S. O sovremennom sostoyanii mashinogo perevoda [The current state of machine translation]. "Voprosy matematicheskoy kibernetiki" [Issues in mathematical cybernetics]. Moscow: Nauka.
3. COLING 78: 7th International Conference on Computational Linguistics: Information Abstracts. Bergen: Univ. of Bergen 1978.
4. COLING 80: Proceedings of the 8th International Conference on Computational Linguistics, 1980

5. COLING 82: Proceedings of the Ninth International Conference on Computational Linguistics. North Holland 1982.
6. COLING 84: 10th International Conference on Computational Linguistics: 22nd Annual Meeting of the Association for Computational Linguistics: Proceedings of the COLING 84. Stanford: Stanford University, 1984.
7. COLING 86: 11th International Conference on Computational Linguistics: Proceedings of COLING 86. Bonn: Univ. of Bonn, 1986.
8. COLING Budapest: Proceedings of the 12th International Conference on Computational Linguistics. Budapest: John von Neumann Society for Computing Sciences. 1988 V 1-2.
9. Hutchins, W. J. Recent developments in Machine Translation. A review of the last five years. "New directions in Machine Translation" 1988 N 1 56 p.
10. New Directions in Machine Translation: Conference proceedings: Budapest 18-19 August 1988. Edited by D. Maxwell, K. Shubert, A. P. Witkam. Budapest: John von Neumann Society for Computing Sciences. Dordrecht/ Providence: Foris Publishers, 1988.
11. Practical experience of machine translation. Edited V. Lawson. North Holland 1982.
12. Slocum, J. A Survey of Machine Translation: its history, current status and future prospects. COMPUTATIONAL LINGUISTICS 1985 V II N 1 pp 1-17.
13. Vauquois, V. La traduction automatique a Grenoble. Paris: Dunod, 1975. Documents de linguistique quantitative N 24.

©Izdatelstvo "Znaniye" 1989

22161
55

NTIS
ATTN: PROCESS 103
5285 PORT ROYAL RD
SPRINGFIELD, VA

22161

This is a U.S. Government publication. Its contents in no way represent the policies, views, or attitudes of the U.S. Government. Users of this publication may cite FBIS or JPRS provided they do so in a manner clearly identifying them as the secondary source.

Foreign Broadcast Information Service (FBIS) and Joint Publications Research Service (JPRS) publications contain political, economic, military, and sociological news, commentary, and other information, as well as scientific and technical data and reports. All information has been obtained from foreign radio and television broadcasts, news agency transmissions, newspapers, books, and periodicals. Items generally are processed from the first or best available source; it should not be inferred that they have been disseminated only in the medium, in the language, or to the area indicated. Items from foreign language sources are translated; those from English-language sources are transcribed, with personal and place names rendered in accordance with FBIS transliteration style.

Headlines, editorial reports, and material enclosed in brackets [] are supplied by FBIS/JPRS. Processing indicators such as [Text] or [Excerpts] in the first line of each item indicate how the information was processed from the original. Unfamiliar names rendered phonetically are enclosed in parentheses. Words or names preceded by a question mark and enclosed in parentheses were not clear from the original source but have been supplied as appropriate to the context. Other unattributed parenthetical notes within the body of an item originate with the source. Times within items are as given by the source. Passages in boldface or italics are as published.

SUBSCRIPTION/PROCUREMENT INFORMATION

The FBIS DAILY REPORT contains current news and information and is published Monday through Friday in eight volumes: China, East Europe, Soviet Union, East Asia, Near East & South Asia, Sub-Saharan Africa, Latin America, and West Europe. Supplements to the DAILY REPORTs may also be available periodically and will be distributed to regular DAILY REPORT subscribers. JPRS publications, which include approximately 50 regional, worldwide, and topical reports, generally contain less time-sensitive information and are published periodically.

Current DAILY REPORTs and JPRS publications are listed in *Government Reports Announcements* issued semimonthly by the National Technical Information Service (NTIS), 5285 Port Royal Road, Springfield, Virginia 22161 and the *Monthly Catalog of U.S. Government Publications* issued by the Superintendent of Documents, U.S. Government Printing Office, Washington, D.C. 20402.

The public may subscribe to either hardcover or microfiche versions of the DAILY REPORTs and JPRS publications through NTIS at the above address or by calling (703) 487-4630. Subscription rates will be

provided by NTIS upon request. Subscriptions are available outside the United States from NTIS or appointed foreign dealers. New subscribers should expect a 30-day delay in receipt of the first issue.

U.S. Government offices may obtain subscriptions to the DAILY REPORTs or JPRS publications (hardcover or microfiche) at no charge through their sponsoring organizations. For additional information or assistance, call FBIS, (202) 338-6735, or write to P.O. Box 2604, Washington, D.C. 20013. Department of Defense consumers are required to submit requests through appropriate command validation channels to DIA, RTS-2C, Washington, D.C. 20301. (Telephone: (202) 373-3771, Autovon: 243-3771.)

Back issues or single copies of the DAILY REPORTs and JPRS publications are not available. Both the DAILY REPORTs and the JPRS publications are on file for public reference at the Library of Congress and at many Federal Depository Libraries. Reference copies may also be seen at many public and university libraries throughout the United States.