

209077

JPRS-TTP-87-014  
26 JUNE 1987



# *JPRS Report*

# Telecommunications

**DTEC QUALITY INSPECTED**

REPRODUCED BY  
U.S. DEPARTMENT OF COMMERCE  
NATIONAL TECHNICAL  
INFORMATION SERVICE  
SPRINGFIELD, VA 22161

19981209 061

20  
67  
A04

## TELECOMMUNICATIONS

### CONTENTS

#### CHINA

PRC To Upgrade Telecommunications Services (XINHUA, 23 May 87) .....	1
Telecommunications Improved on Hainan Island (XINHUA, 9 May 87) .....	2
Guangzhou-Haikou Radio, TV Microwave Link Begins (Guangdong Provincial Service, 2 May 87) .....	3
Briefs	
Interregional Rural Telephone Group Formed	4
Radio, TV Cooperation Agreement Signed	4
Digital Communication Line Verification	4

#### EAST ASIA

##### HONG KONG

Telco Official Opposes Opening Up Telecom Field (HONGKONG STANDARD, 30 Apr 87) .....	5
---	---

##### PHILIPPINES

Private Sector Telecommunications Efforts Urged (Carol I. Guevarra; BUSINESS DAY, 18 May 87) .....	6
---	---

#### EAST EUROPE

##### POLAND

Briefs	
Fibreoptics in Telecommunications	8

NEAR EAST & SOUTH ASIA

BANGLADESH

Lack of Funds Cripples Telephone Communications  
(THE BANGLADESH OBSERVER, 3 May 87) ..... 9

Nonuse of Jhenidah VHF Microwave System Deployed  
(THE BANGLADESH OBSERVER, 13 May 87) ..... 10

Briefs  
Automatic Telephone Exchanges ..... 11

INDIA

Communications Minister Details Future Telephone Plans  
(PATRIOT, 1 May 87) ..... 12

Petition Challenges Government Use of Radio  
(THE TIMES OF INDIA, 29 Apr 87) ..... 13

Launching of Indian Remote Sensing Satellite in 1990's  
(PATRIOT, 30 Apr 87) ..... 14

Engineering Firm Enters Telecommunications Field  
(PATRIOT, 25 Apr 87) ..... 15

Briefs  
Ericsson Telephone Manufacture ..... 16  
Television Network Expansion ..... 16

PAKISTAN

Satellite Launch Said Delayed 5 Years  
(THE MUSLIM, 9 May 87) ..... 17

Briefs  
Yaquib Khan on French Proposal ..... 18

SOVIET UNION

Moscow-Washington TV Link-Up Shown to Media  
(TASS, 22 May 87) ..... 19

Spokesman Confirms Halt to Jamming of VOA  
(AFP, 26 May 87) ..... 20

Telebridge 'Expert' Views Khrushchev, Brezhnev Eras  
(Moscow Television Service, 23 May 87) ..... 21

Briefs  
USSR, PRC Sign Radio, TV Agreement ..... 22

WEST EUROPE

EUROPEAN AFFAIRS

EEC Announces Mobile Telephone Plans  
(EC INFORMATION MEMO, No P-6, Feb 87) ..... 23

DENMARK

Minister Proposes Comprehensive Broadcasting System Reform  
(H. P. Clausen; AKTUELST, 10 Apr 87) ..... 26

Parliament To Allow Antennas To Compete With Hybrid Net  
(BERLINGSKE TIDENDE, various dates) ..... 30

Parliament, Government Compromise, by Morten Larsen 30  
25 Channels Via Antennas, by Jan Jorgensen 32  
Hybrid Net Costs Cited, by Morten Pihl 33  
Parabolic Antenna Sales Boom, by Jan Jorgensen 34

Nordiske Kabel- OG Traadfabrikker Emphasizing High Technology  
(Erik Bendt-Rasmussen; BERLINGSKE TIDENDE, 26 Mar 87) ... 35

FEDERAL REPUBLIC OF GERMANY

D2-MAC To Be TV-Standard for France, FRG  
(HANDELSBLATT, 28-29 Mar 87) ..... 37

FRANCE

Plans, Design, Equipment for ISDN Network Through 1988  
(Jacques Guitonneau; FRANCE TELECOM, Feb 87) ..... 40

Briefs  
New French News Radio 48

SPAIN

Ericsson Becomes Whole Owner of Intelsa  
(Willy Silberstein; SVENSKA DAGBLADET, 14 Apr 87) ..... 49

SWEDEN

Ericsson Buys 20 Percent of French CGCT  
(Ewa Hedlund, Christer Hedberg; SVENSKA DAGBLADET,  
24 Apr 87) ..... 51

Deregulation To Help Ericsson on Foreign Markets  
(Gote Andersson; SVENSKA DAGBLADET, 2 Apr 87) ..... 54

Ericsson, State Agency in Contest for Phone Switch Market (Gote Andersson; SVENSKA DAGBLADET, 14 Apr 87) .....	57
Briefs	
Joint Data Communications Venture	60
TURKEY	
Briefs	
TV Transmitter	61

/7310

CHINA

PRC TO UPGRADE TELECOMMUNICATIONS SERVICES

OW231106 Beijing XINHUA in English 0941 GMT 23 May 87

[Text] Chengdu, 23 May (XINHUA)--China will build 17 key telecommunications centers and finish updating 10 existing centers during the Seventh 5-Year Plan (1986-90).

"Projects will also include 20 satellite ground stations and two international postal centers in Beijing and Shanghai," Zhang Duanquan, a bureau director of Ministry of Posts and Telecommunications said at the ongoing Fifth National Meeting on Capital Construction for Telecommunications Services.

"During the period, 2.5 to 3 million local telephone lines and 60,000 long distance lines will be added," he said. "and a computer-controlled direct-dial system linking all capital cities and major coastal cities will also be installed."

"Posts and telecommunications services are a weak link in the country's national economy," Zhang said, "so, we have to focus our limited funds on key state communications projects."

Reviewing achievements made in the 1981-1985 period, Zhang said, "China has invested some 5.8 billion yuan (1.6 billion U.S. dollars) in 13 states key telecommunications projects and 38 other projects since 1981."

"China added 1,8 million local telephone lines, including computer-controlled switchboards for 320,000 telephones, and 21,599 long distance lines during the same period," Zhang added.

/9274

CSO: 5500/4157

CHINA

TELECOMMUNICATIONS IMPROVED ON HAINAN ISLAND

OW091145 Beijing XINHUA in English 1015 GMT 9 May 87

[Text] Beijing, 9 May (XINHUA)--Hainan Island, off the coast of south China's Guangdong Province, has accelerated construction of telecommunications facilities, partly to meet the needs of foreign investors, the PEOPLE'S DAILY (OVERSEAS EDITION) reported today.

By the end of next year, automatic telephones will be installed in most counties and cities to replace the outmoded hand-set telephones now in use.

Automatic telephones are now available in Qionghai, Qionghshan, Wanning, Sanya and Tongshi Counties; and local authorities plan to install 3,600 lines this year and 5,800 lines in 1988.

A postal center and a program-controlled telephone project with a capacity of 5,000 lines are under construction.

With the completion of the Haikou Station of the west Guangdong 1,800-km microwave telecommunication line in April 1986, the number of long-distance telephone lines are increased to 300 in Haikou. Now Haikou has direct facsimile and telephone services connecting it with Guangzhou, Beijing and Shanghai.

A microwave telecommunication link from Haikou to Sanya, on the southern tip of the island, with a capacity of 960 lines, has basically been completed and tourists will soon be able to make direct telephone connections with Guangzhou and Hong Kong.

The local authorities also put into service a 320-km underground cable across the country's second-largest island from south to north at the end of last year. It can handle telephone, facsimile, broadcast, and closed-circuit television services.

Now residents of the island can receive Beijing television programs.

/9274

CSO: 5500/4157

GUANGZHOU-HAIKOU RADIO, TV MICROWAVE LINK BEGINS

HK030613 Guangzhou Guangdong Provincial Service in Mandarin 0300 GMT 2 May 87

[Excerpt] The Guangzhou Haikou radio and television microwave circuit was inaugurated this morning. Thus some 20 million people in 25 cities and counties in the southwestern part of Guangdong will be able to see the programs of the provincial television station on the day of transmission.

This circuit, over 600 km long, runs through Jiangmen, Maoming, and Zhanjiang, and crosses the Hainan Strait to Hainan Island. Using this circuit, Guangzhou can transmit 4 channels of color television, including audio, and 12 radio channels to Haikou and the microwave stations along the circuit. Haikou can also transmit two television channels and six radio channels to Guangzhou. This circuit has relatively wide range of facilities and a relatively full set of equipment in China's radio and television system.

Zeng Dingshi, vice chairman of the provincial People's Congress Standing Committee; Vice Governor Kuang Ji; Cai Hui, director of the provincial radio and television department; and leading comrades of the Ministry of Finance and the Ministry of Radio, Cinema and Television attended the inauguration of the circuit.

/9274

CSO: 5500/4158



## BRIEFS

INTERREGIONAL RURAL TELEPHONE GROUP FORMED--Guilin, 17 May (XINHUA)--An inter-regional rural telephone communication group was set up yesterday, XINHUA learned from the China National Posts and Telecommunications Industry Corporation. The group is composed of 15 factories and research institutes involving the telecommunications equipment production. It aims mainly at developing the markets of the equipment of telecommunications, organizing the relevant products and providing services for subscribers. By the end of last year, 20 provinces and autonomous regions nationwide had set up their rural telephone bureaus and management divisions. The local governments strengthened the leadership over the work and collected funds and loans for the construction. China's telephone exchanges run by the local authorities, the collectives of towns and villages and individuals amounted to about 50,000 last year. The number of telephone sets owned by peasants increased by 76 percent over the previous year. Specialists said that the capacity of existing telecommunications still cannot meet the needs of the developing rural economy. The establishment of the group is expected to go a long way to help meet the needs. [Text] [Beijing XINHUA in English 1419 GMT 17 May 87 OW] /9274

RADIO, TV COOPERATION AGREEMENT SIGNED--Beijing, 21 May (XINHUA)--An agreement between China and the Soviet Union on the cooperation of television and radio was signed here today. The document was signed by Ma Qingxiong, Chinese vice minister of radio, film and television, and Popov, vice chairman of the State Committee of USSR for Television and Radio Broadcasting. Chinese Minister Ai Zhisheng of the radio, film and television (ministry) attended the signing ceremony. [Text] [Beijing XINHUA in English 1152 GMT 21 May 87 OW] /9274

DIGITAL COMMUNICATION LINE VERIFICATION--Fuzhou, 21 May (XINHUA)--China's first domestic digital microwave communications line between Fuzhou and Xiamen passes tests in Fuzhou 20 April and has been put into operation. It can transmit telephone, telegram, and television digital signals. Its technical performance has reached the advanced world standards of the 1980's. [Summary] [Beijing XINHUA Domestic Services in Chinese 1307 GMT 21 Apr 87 OW] /9274

CSO: 5500/4158

## TELCO OFFICIAL OPPOSES OPENING UP TELECOM FIELD

Hong Kong HONGKONG STANDARD in English 30 Apr 87 p 4

[Text]

ABOUT 40 percent of Hongkong's telecommunications business is competitive with dozens of companies involved and this percentage is likely to rise to 50 percent in the next five years.

This was said yesterday by the Corporate Marketing Manager of the Hongkong Telephone Company (Telco), Mr John York-Williams.

These services, he stressed, should be run on the one existing network operated by the Telco.

Telco has invested \$3.2 billion over the past five years. The company's turnover for the year 85-86 was \$2.8 billion while its net profit was \$0.7 billion.

Mr York-Williams said a further \$3.9 billion would be spent on the network in the next three years.

This investment has made Hongkong's existing network "one of the finest and most rapidly modernising in the world," Mr York-Williams said.

A second network, he added, would only be a duplication of effort and hamper Telco's plan to develop its system.

The controversy over whether Hongkong should have an alternate telecommunications network was sparked off by proposals to introduce cable television.

Eight groups — one of which is backed by Telco — have indicated an interest in providing the service.

While Telco wants to have cable television run on its

network one of its rivals, Hutchison CableVision wants to build its own network to carry not only cable television, but also other potentially lucrative telecommunications services.

Mr York-Williams said Telco welcomed the Government's review of its telecommunications policy as the company believes current legislation has been made obsolete by recent technological advances.

"Hongkong Telephone is arguing strongly for the retention of one exclusive network for the carriage of all services, with only telephone remaining exclusive to the company.

"All other services can be run on the network on a competitive basis.

"We are asking to retain our franchise, which runs until 1995, and to continue to run the only telecommunications network for Hongkong under Government regulations," he said.

Mr York-Williams also said "claims" that a second network will lead to greater efficiency and better prices are "unfounded taken as a whole."

He said only three countries had allowed competitive networks — the United States, Britain and Japan — but only for long distance calls.

Hongkong is so small it does not have a long distance network, he said.

He claimed that in the United States and Britain the competition has led to price hikes and has failed to improve services.

/9274

CSO • 5550/0136

## PRIVATE SECTOR TELECOMMUNICATIONS EFFORTS URGED

HK181355 Quezon City BUSINESS DAY in English 18 May 87 p 3

[By Carol I. Guevarra]

[Excerpts] The Department of Transportation and Communication will come up with more definite policies for the telecommunications industry to encourage more private investments in the sector, Secretary Rainerio O. Reyes said.

In a speech delivered at the opening ceremonies of the National Telecommunications Week last Saturday, Reyes underscored the importance of telecommunications in the overall economic development program and emphasized the need for greater private sector initiative in the industry.

On the role the private sector has to play, Reyes said private telecom firms must "provide the capital and service to mobilize technical expertise in setting up facilities not only in the urban but particularly in the rural areas."

Reyes noted that while international service compares favorable with systems found in other places, the domestic services, both for voice and record, leave much to be desired.

Reports show that as of end 1986, there were 13 provinces and eight cities still without telephone service while around 300 municipalities and towns do not have the basic telegraph system.

To overcome these deficiencies, various telecommunication companies are undertaking development and expansion projects. Among these are the X-5 program of the Phil. Long Distance Telephone Co., the Piltel expansion and modernization program, the regional (rural) telecommunications development project of the Bureau of Telecommunications, and the Data Network project using the packet switching technology of PT&T.

Meanwhile, telecommunication companies have appealed anew to the government for more support in the development of telecommunications infrastructure in the country.

Citing the vital role of communications in the country's economic recovery, the Philippine Electronics and Telecommunications Federation, the umbrella organization representing the private sector in the telecommunications industry, reiterated the appeal in the hope that policy-planners would now give more priority and attention to the sector when formulating socioeconomic development programs.

/9716

CSO: 5500/4 321

## BRIEFS

FIBREOPTICS IN TELECOMMUNICATIONS--Warsaw, May 14--In advance of the International Telecommunications Day falling May 1, Polish Vice-Minister of Telecommunications Kazimierz Czarniecki told PAP about new developments in this sector of Polish industry. One of them is a microchip-controlled telephone exchange board for small localities with the capacity of up to 100 numbers, about 80 such switchboards will be turned out by the end of this year. Also, fibreoptic cables will be employed for the first time in Poland in telephone connections of Lodz, Poznan and Warsaw. The system will consist of about 1,500 connections linking exchanges in these towns. It is worth noting that Poland continues to be the only socialist country that has fully mastered the production of the world's most-widely used digital telephone exchange boards type E-10. [Text] [Warsaw PAP in English 1036 GMT 14 May 87 LD]

/9716

CSO: 5500/3016

## LACK OF FUNDS CRIPPLES TELEPHONE COMMUNICATIONS

Dhaka THE BANGLADESH OBSERVER in English 3 May 87 pp 1, 8

[Text]

T & T Board, whose chief obligation is to provide new telephone connections and ensure system's upkeep is not in a position to give any more new connection in Dhaka City.

The eleven exchanges now in operation of supporting telephone communication in Dhaka City and its outskirts are over jammed.

New connections can only be given at the risk of damaging the exchanges. All the exchanges are carrying a 100 per cent load defying the restriction of a maximum of 85 per cent load for each exchange.

Over one lakh applications for new telephone connections are pending for approval. A senior official of the T & T Board said these applications are not likely to be cleared even by the terminal year of the Third Five Year Plan.

It was gathered over eight thousand demand notes have been issued ignoring the load capacity and there is no guarantee that they would be given telephone connections.

The T & T Board had asked the Planning Commission to make provision for 60,000 additional lines in the current ADP. The Planning

Commission turned down the request and even refused to include the scheme in the ADP for 1987-88. Paucity of funds was stated to be the reason for Planning Commission's inability to include the scheme in the ADP.

The T & T Board had sought an allocation of Tk. 800 crore for the expansion and improvement of the telecommunication system in the country during the Third Five Year Plan period. The Planning Commission responded with an allocation of Tk. 250 crore.

The T & T Board was not even given Tk. 50 crore that it was promised as yearly allocation out of the money earmarked for it in the Third Five Year Plan. It received an

allocation of Tk. 12 crore only in the current fiscal year for development purpose.

Donors are eager to assist Bangladesh in improving its telecommunication network but the lack of matching fund is halting the process. Japan is ready to help in setting up 30,000 new telephone lines. An agreement in this respect signed during President Ershad's visit to Japan last year. No progress has been made due to the non-availability of taka component of the fund.

The Telephone Shilpa Sangtha is facing an acute financial crisis. It has been producing 8000 telephone sets a year instead of 20,000 sets it is capable of producing.

TSS has deliberately scaled down the production target for poor absorption capacity. TSS employs over 1000 persons and had enough to pay the wages for the month of May. It will have to look for funds to pay its employees from June.

The cable production likewise has been maintained at 10 per cent of the capacity.

/9274

CSO: 5500/0141

## NONUSE OF JHENIDAH VHF MICROWAVE SYSTEM DEPLORED

Dhaka THE BANGLADESH OBSERVER in English 13 May 87 p 7

[Text]

JHENIDAH, May 10:—The telephone subscribers of Jhenidah District Headquarters have been suffering much due to absence of direct trunk call line between Jhenidah and Divisional Headquarters of Khulna for a long time.

Jhenidah is a busy commercial centre and also important district headquarters. So education and communication network with all the district towns including the capital every day about 100 trunk calls are booked for Khulna. But most of the calls are cancelled for not getting telephone line from Khulna via Jessore and Magura telephone exchanges.

The people, specially the businessmen and administration of the District Headquarters have been facing a lot of inconveniences owing to the absence of the system.

It may be mentioned here that at present the availability of telephone line of Khulna fully depends on the kind consideration of the operators on duty at Jessore and Magura Telephone Exchanges.

It is learnt from a reliable source

that it is a matter of a few minutes to connect Jhenidah Exchange with Khulna Exchange directly through VHF Microwave System is located at Jhenidah. But it is alleged that a section of T and T officials is not interested to connect Jhenidah Telephone Exchange with Khulna Telephone Exchange for some unknown reason.

It may also be noted here that the VHF Microwave System was constructed at Jhenidah at a cost of over Taka 10 lakh with the provision for 60 channels to connect Jhenidah Telephone Exchange with different telephone exchanges of the country about 12 to 15 years ago. But only 3 channels are operating at present in this VHF Microwave System with Jessore and Dhaka only out of the 60 channels.

The remaining 57 channels are lying idle due to alleged negligence of the authority concerned.

It may be further noted here that the telephone line of Magura, Kushtia and Chuadanga which are 18, 28 and 22 miles away from Jhenidah also depend on the good condition

of physical line instead of Microwave System. As a result, every day a large number of trunk calls booked for Magura, Kushtia and Chuadanga are to be cancelled after an endless wait for frequent fault of physical lines of those places.

It is the question of Jhenidah people that why the VHF Microwave System was constructed at Jhenidah by spending several lakhs of Taka about 12 to 15 years ago if the system does not operate.

The crop cutting ceremony was held at village Majhail under Shailkupa Upazila of Jhenidah District recently.

Mr. Saharuddin, Assistant Director of Jhenidah District Agricultural Extension Department attended the ceremony as chief guest while a leading farmer of the locality Mr. Jahar Ali presided over the function.

Speaking on the occasion, the Assistant Director urged upon the farmers to cultivate crop by adopting scientific method of cultivation in the field for boosting the production.

/9274

CSO: 5550/0142

## BRIEFS

AUTOMATIC TELEPHONE EXCHANGES--Char Alekjandar (Ramgati), 13 Apr--Prime Minister Minanur Rahman Chowdhry said yesterday that automatic telephone exchanges would be established in all the upazilas during the 3rd 5-Year Plan period. Inaugurating a 200-automatic telephone exchange here on Saturday the Prime Minister said the declared policy of the present government was to bring all the upazilas under the telecommunication network and to modernise the existing telephone system. [Excerpt] [Dhaka THE BANGLADESH OBSERVER in English 17 Apr 87 p 7] /9274

CSO: 5550/0143



## COMMUNICATIONS MINISTER DETAILS FUTURE TELEPHONE PLANS

New Delhi PATRIOT in English 1 May 87 p 5

[Text]

The telephones department will provide 240,000 new telephone connections this year by adding another 300,000 lines to the exchange capacity, reports UNI.

Giving this information to the consultative committee attached to his ministry, Communications Minister Arjun Singh said in New Delhi on Thursday that during the year 1200 long distance public call offices would be opened in rural areas.

In the transmission field 2303 route km of microwave, 1032 km of coaxial and 1375 km of ultra high frequency would be added. In addition to this 20,500 new trunk automatic exchange lines would be added to the network.

The minister said the department was able to cross last year the landmark of additional 300,000 lines in a year for the first time by adding 324,000 telephone connections against the target of 220,000 lines. With this the country now has about 3.48 million working telephone connections.

In all the 808 more telephone exchanges were added to the main telecom network. These achievements were possible by expediting the installations and close monitoring of the functioning at various levels of the department. The target of opening of 1120 long distance public telephones in the rural areas was also exceeded with the provision of 1558, the minister added.

On 'mission—better communication', the minister said the efforts of the department to improve the service have started

showing results. Faults rates have come down and call success rates and trunk efficiency have shown some improvement. There has been a definite change for the better in attitude of staff towards the customer needs and expectations.

On postal side, Mr Arjun Singh said that International Speed Post traffic has been picking up in both directions. It is proposed to expand Speed Post services to other countries in a phased manner in the near future.

In order to speed up the transmission and delivery of second class mail from the mainland for Andaman and Nicobar islands, second class mails from the mainland are being airlifted with effect from March this year without any surcharge.

## PETITION CHALLENGES GOVERNMENT USE OF RADIO

Bombay THE TIMES OF INDIA in English 29 Apr 87 p 9

[Text]

NEW DELHI, April 28.

**T**HE supreme court today admitted a writ petition challenging the Union government's use of All India Radio and Doordarshan as a near exclusive voice of the ruling party. The petition has been filed by Mr Romesh Thapar, editor of "Seminar."

A division bench comprising the chief justice, Mr R. S. Pathak and Mr Justice Ranganath Misra has issued a notice to the Union government returnable on July 21. This is the first time that the supreme court is addressing itself to such issues.

The petition argues that the manner of functioning of AIR and Doordarshan violates the fundamental rights of citizens enshrined in Articles 14, 19 and 21 of the Constitution, which guarantee equality before the law, right to freedom of speech and protection of life and personal liberty. The petitioner has asked the court to direct the Union government to refrain from violating his rights.

The petition argues that the "fundamental right to freedom of speech and expression includes the right to receive information and the right to know without imposing any unreasonable impediment or restriction on the exercise of the said rights." The monopoly given to AIR and Doordarshan, it says, is "a national asset to be used exclusively for public purposes in ac-

cordance with the Constitution."

Mr Thapar, who is being represented by the well-known constitutional expert, Mr A. G. Noorani, has cited several examples to argue that the two official media organs have been reduced to become propaganda instruments for the ruling party, the Congress, and the Prime Minister, Mr Rajiv Gandhi.

This, says the petition, violates every Indian citizen's fundamental right "to insist that significant differences of opinion on important questions of public policy be allowed fair and equal access" to the public media.

Arguing that there has long been "widespread dissatisfaction" over the working of AIR and Doordarshan, the petition gives the history of this dissatisfaction, starting with the establishing of the Chanda committee and the government's decision to turn down its recommendation granting "full autonomy" to AIR and Doordarshan. Quoting a later committee headed by Dr P. C. Joshi, the petition argues that the two official media do not even have "functional freedom", since they have to function under "telephone calls regarding newscoverage".

The petition points out that unlike all other democratic countries where the status, objects, functions and powers of the public broadcasting services and television are defined by law, "there exists no such legislation in India." What is more, the two media organs often violate the guidelines set

by the Union government itself. In effect, says the petition, Doordarshan and AIR are run "according to the wishes and to promote the interests of the political party in power at the Centre and its leader, Mr Rajiv Gandhi."

The two media organs, it argues, are so obsessed with the doings of the Prime Minister and other ministers that it has no inclination to record the struggle of the common man. The petition quotes Dr Joshi's report lamenting "that a television system which is not only publicly funded but is also directly run by the government, on the ground that this is necessary to make television serve the purpose of development in the direction of socialism, should show so little orientation towards the common people in its news and current affairs programmes."

The petition quotes Mr Rajiv Gandhi's frequent expression of dismay at Doordarshan's obsession with him but charges that the continuation of the malady is because of the lack of any "institutional protection of independence or autonomy of the professionals or provision for accountability."

While conceding that it is not open to any citizen to insist that he should be permitted access to the official media, the petition wants the court to declare that the functioning of AIR and Doordarshan are subject to a citizen's fundamental rights.

/9274

CSO: 5550/0145

## LAUNCHING OF INDIAN REMOTE SENSING SATELLITE IN 1990'S

New Delhi PATRIOT in English 30 Apr 87 p 5

[Text]

India would be able to launch its own remote sensing satellite in early 1990s, Minister of State for Science and Technology and Space, K R Naryanan, informed the Lok Sabha on Wednesday, reports PTI.

He told Mr P R S Venkatesan during question hour that the first in the series of Indian Remote Sensing Satellites (IRS-IA) would be launched by a Soviet rocket carrier. It was expected to take place during 1987.

The second in the series, IRS-IB, would also be launched from abroad. The launch of IRS-IB, he said, was nominally scheduled for 1989/90 "but will be finally decided after reviewing the performance of IRS-IA."

Mr Naryanan said the Indian Space Research Organisation (ISRO) was to pay Rs 7.50 crore to the USSR Foreign Trade Agency Licensintorg (LIT) for the launch of IRS-IA and other related services.

The IRS satellite, he said, was expected to provide high quality satellite data for use in a variety of disciplines, such as forestry, hydrology, geology and agriculture.

IRS, he said, would not however be directly useful in meteorology related observations.

Mr Naryanan said in the area of forestry, classification of different types of trees in forests and information of their stages of growth could be obtained with the help of IRS leading to estimates of forest wealth and a continuous monitoring of the increase/reduction in forest cover.

Also, valuable information on water resources including information on snow cover, surface runoffs, reservoir areas, drainage network and flood mapping could be obtained.

Hydro-geological features, he said would provide information on ground water. These data would assist in the effective planning for use of water resources.

The Minister said geological information from satellite remote sensing would provide data on structural geology, mineral exploration, mapping and map updating.

In coastal oceanography, identification and location of sea food, surveillance of coastal erosion, coastal currents, sedimentation and marine pollution would be possible through use of appropriate satellite data.

/9274

CSO: 5550/0146

## ENGINEERING FIRM ENTERS TELECOMMUNICATIONS FIELD

New Delhi PATRIOT in English 25 Apr 87 p 9

[Text]

Escorts, the fifth largest engineering company in the private sector, has now diversified into the field of telecommunications and has for this purpose entered into a technical collaboration with Jeumont-Schneider of France for manufacturing of EPABXs (electronic private automatic branch exchanges) with a capacity of 8 to over 5000 extension lines.

Talking to newsmen in Delhi on Thursday, Mr R P Nanda, vice-chairman Escorts said that the plant at Ballabgarh was slated for commercial production in the first week of May 1987. Escorts EPABX systems would provide a large number of trunk tie line connections to enable greater traffic flow among exchanges. Subscribers within the network can communicate with each other freely as tie lines do not get congested. Moreover, 2 wire E&M pulse signalling enables connection of two EPABXs through P&T lines or radio links, Mr Nanda said.

The Escorts EPABX systems, Mr Nanda said, also permit assigning of a unique and uniform number to each subscriber in the network, with no need to remember the number of each subscriber. There are no tie line codes to be remembered or dialled. The

system also ensures automatic routing of cables through alternative routes in case the direct route is busy. It is also possible to establish calls between subscribers of two EPABXs not directly connected but connected to a third EPABX. Calls can also be established between subscribers of two EPABXs through an intermediary EPABX in the same manner without any manual assistance, Mr Nanda said.

He said that Escorts was the first company among the DOE and DOT approved technology to exhibit networking through their own EPABXs. The company is also to take up allied telecommunications and office automation products soon, Mr Nanda said.

About their collaborator, Mr Nanda said that M/s Jeumont-Schneider was part of a first French private industry group with a turnover of 30 billion franc of which 50 per cent is the export turnover. J-S in particular has more than 16,000 people and a turnover of one billion dollars with exports accounting for 35 per cent. The J-S technology is approved by 30 foreign countries with licensees at US, Italy, Tunisia, Turkey, Argentina, Yugoslavia and India. Jeumont-Schneider have also their interests in energy, industry and rail transport.

/9274

CSO: 5550/0144

## BRIEFS

ERICSSON TELEPHONE MANUFACTURE--Bombay, 1 May--India will manufacture Ericsson telephone sets under the terms of a licensing agreement worth more than Rs. 45 crores over the next eight years. Ericsson Information Systems AB has won approval from the department of electronics of the government of India for licensing agreement covering the local production of telephone sets. The licences are valid for eight years, and together cover the production up to two million electronic push-button telephones per year for the Indian market. Currently, four Indian companies have licences with Ericsson. There are Punwire, Rajasthan Telephone Industries, United Communications and Swede India Teltronics. Production is expected to be in full swing during the current calendar year. [Text] [Bombay THE TIMES OF INDIA in English 2 May 87 p 11] /9274

TELEVISION NETWORK EXPANSION--Bhubaneswar, 26 Apr--If the information given by the Union Minister of State for Information and Broadcasting, Mr Ajit Kumar Panjar, at a Press conference here yesterday is any indication, the All India Radio-Doordarshan network in Orissa is going to be expanded in a big way in the coming years, reports UNI. He said during the remaining three years of the Seventh Plan, Doordarshan would have a studio centre here, high-power 10 KW transmitter at Bhawani Patna in place of the existing one, and 100-wt transmitters at Baripada, Sundergarh, Balasore, Keonjhar, Bolangir, Phulbani, Jeypore and Bhanjanagar. Till the Sixth Plan end, the Doordarshan network in Orissa comprised high-power transmitters in Cuttack (10 KW) and Sambalpur (1 KW), and a 100-wt TV transmitter was installed and commissioned at Bhawani Patna. Mr Panja said the local radio station that was approved for Keonjhar during the Sixth Plan was being installed and was expected to be commissioned by March, 1988. With this, the coverage would increase to 80% by area and 88% by population. He said during the Seventh Plan, five radio stations were proposed to be set up at Bhawani Patna, Berhampur, Baripada, Rourkela and Bolangir. The Minister said about 430,000 people would be benefitted when the radio transmitter at Jeypore was upgraded. With the implementation of all these schemes [words indistinct] 91% area and 98% population was expected to be covered, he added. [Text] [Calutta THE STATESMAN in English 27 Apr 87 p 6] /9274

/9274

CSO: 5550/0148

## SATELLITE LAUNCH SAID DELAYED 5 YEARS

Islamabad THE MUSLIM in English 9 May 87 p 8

[Text]

KARACHI, May 8: The proposal to place a Pakistani communications satellite in earth orbit "is not moribund" though financial constraints have pushed back the launch schedule by about five years, official sources said here today.

The PAKSAT projects implementation is now envisaged as coming within the Seventh Five-Year Plan period 1988-93, they added.

Originally, the multi-million dollar scheme was targeted for completion by next year—that is, by the end of the Sixth Five-Year Plan period but a number of factors combined to delay the launching of the satellite. The main one among these was the cost of fabricating and launching the satellite and constructing the network of ground receiving and transmitting stations which would utilise it.

The executive committee of the Space Research Council (SRC) has constituted a special sub-committee, headed by Dr. M.A. Kazi, Adviser to the Prime Minister for science and technology, to examine the entire satellite project in depth, especially its economic aspects and cost.

The sub-committee has held two meetings so far, the first in mid-1986 and the second one month ago, and is now nearing completion of its work.

The proposed communications

satellite if and when launched will provide nearly 5,000 two-way telephone circuits, half exclusively for rural areas, two television channels, a radio channel and provisions for link-ups between newspapers and computers located in different cities.

Officials concerned with evaluating the project noted that it had educational aspects since the experience of other countries showed that satellites could be used to beam educational and adult literacy programmes to rural areas.

Utilising the satellite's orbital position television and radio programmes could be directed towards people living in the northern areas and remote parts of Baluchistan who at the moment cannot receive them due to geographical factors (intervening mountains and distance from ground transmitting stations).

The satellite can make 'video conferences' also possible by providing government officials and businessmen, the means to hold discussions with colleagues in other cities linked to each other through satellite circuits.

Among other things, the sub-committee of the SRC is comparing the telephone tariff structure imposed in other countries using communications satellite to see how such changes could be introduced here eventually and what difference they would make to the existing rates.

While the advantages and disadvantages of satellite and ground-based communication systems are being examined by the sub-committee, the sources noted that in any case PAKSAT was not meant to replace the ground telephone network, but was rather designed to complement it by providing alternative channels and easy access to rural areas.—APP

/9274  
CSO: 5500/4721

## BRIEFS

YAQUB KHAN ON FRENCH PROPOSAL--Foreign Minister Sahabzada Yaqub Khan has described his recent visit to the United States as fruitful and said the attitude of U.S. leaders to our urgent requirement for an effective airborne early warning system is sympathetic. On his return trip, the foreign minister also met with his French counterpart, Jean Raimond, in Paris and held talks with him on international issues and matters of mutual interest. In reply to a question, he said that Pakistan is very carefully considering the proposals made by France on the issue of a nuclear reprocessing plant. He said that he is hopeful of an early and mutually satisfying settlement on the issue. This will provide a fresh impetus to effective future cooperation in economic and technological fields, including nuclear power generation. [Excerpts] [Karachi Domestic Service in Urdu 0200 GMT 28 May 87 BK] /9274

CSO: 5100/4749

## MOSCOW-WASHINGTON TV LINK-UP SHOWN TO MEDIA

LD220445 Moscow TASS in English 0136 GMT 22 May 87

[Text] Moscow May 21 TASS -- "Let us get acquainted" was the watchword of the first TV space hook-up between deputies of the USSR Supreme Soviet and members of the U.S. Congress, whose recording was for the first time shown to Soviet newsmen today.

The television dialogue opened with the statement by William Uri of Harvard University, a prominent expert in the conduct of talks, who said among other things that the aim today is not to recall the differences but try and reach agreement, speak with one another, but not over each other's heads, in the first place to learn to listen, since the dialogue between our countries often reminded a conversation of two deaf persons.

The TV hook-up has proved to be a success: Albeit the mutual familiarisation brought out considerable differences in the work done by the MPs, this did not lead to any confrontation. On the contrary, the participants in the 80-minute conversation displayed a mutual wish to analyse the distinctive features of their legislative experience and exchange knowhow.

Is a person entitled to nominating his own self to run for parliament, are election publicity shows necessary, is a deputy responsible to his electorate, what is the gist of the new Soviet election law? All these and many other questions touched off a lively discussion, taking part in which from the Soviet side were in particular deputies Vadim Zagladin, Georgiy Arbatov, Irina Blokhina and Kiril Lavrov, from the American side -- Senator Alan Cranston, Congressmen George Brown, Claudine Schneider, Tom Downey and others.

Winding up the discussions, Claudine Schneider, Republican representative from Rhode Island, said that the potential of TV hook-ups between law-makers is vast. She expected an even broader exchange of information. She expressed optimism that this process would very soon bear its good fruit.

The success of the first television hook-up predetermined the possibility of continuing the dialogue of MPs across the ocean. As newsmen were told, three television discussions were scheduled for September, October and November. They are devoted to burning problems -- arms control, human rights and regional conflicts.

/9274  
CSO: 5500/1044



SPOKESMAN CONFIRMS HALT TO JAMMING OF VOA

AU261510 Paris AFP in English 1459 GMT 26 May 87

[Text] Moscow, May 26 (AFP) -- The Soviet Union confirmed Tuesday that it has stopped jamming Voice of America radio broadcasts as part of its policy of "glasnost," or openness, but said it would continue to block two other U.S. stations because they were "remnants of the cold war."

Foreign Ministry spokesman Yuriy Gremistkykh said Radio Free Europe and Radio Liberty would still be prevented from broadcasting to Eastern Europe. He described the two stations as "ideological tools" controlled by the CIA, the U.S. intelligence service.

The spokesman told reporters here that Moscow would not retaliate against new U.S. State Department regulations for East bloc journalists based in Washington. But he said the measures announced last week were "discriminatory" and a violation of the 1975 Helsinki accords on security and cooperation.

Eastern European journalists in the U.S. capital must now be escorted when visiting the State Department's press office. "But we shall not play along with the Americans, we shall not take any counter-measures," Mr. Gremistkykh said.

Questioned on the possible effects of glasnost on the status of Western correspondents in Moscow, the Foreign Ministry spokesman forecast developments for later this year.

/9274

CSO; 5500/1045

## TELEBRIDGE 'EXPERT' VIEWS KHRUSHCHEV, BREZHNEV ERAS

LD232121 [Editorial Report] Moscow Television Service in Russian at 1749 GMT on 23 May broadcasts a 1 hour 20-minute recording of a Moscow-Washington televised linkup between members of the USSR Supreme Soviet and the U.S. Congress in which a Soviet expert praises Khrushchev's "bold and courageous" trip to the United States and lauds Brezhnev's arms control "initiatives."

Professor Guliyev, present in the Moscow studio in the capacity of, in his own words, an "independent expert," says: "My generation, for instance, remembers above all not the mistakes or shortcomings permitted or committed when Khrushchev was leader of our party and state, but, among his first acts, his very bold and courageous action to defend peace, to defend and consolidate relations between the Soviet Union and the United States: his trip to the United States. It took place despite the fact that there were objections, as far as I know, from certain circles in the United States and it seems to me that there were also some doubts in Soviet circles about this."

He goes on to discuss the Brezhnev period: "We are highly critical at present -- we are assessing critically, both positively and, so to speak, negatively, the events which took place at the period when Leonid Brezhnev was leader of the party and state. But at the same time, there remains in my generation and my children the memory of those actions which are associated with his initiatives, or at any rate, there remains the fact that he voiced the initiatives of the Soviet Union and the Soviet leadership on a number of vital issues concerning the existence of mankind: arms limitation, attempts to find agreement, the concluding of the SALT I Treaty -- er, agreement, the concluding of the SALT II treaty, the concluding of the ABM agreement of indefinite duration, his work to normalize relations with the Federal Republic of Germany, and so on and so forth. This is despite the fact, I repeat, that we critically assess certain actions of this period, above all in the sphere of our domestic affairs."

/9274

CSO: 5500/1045

BRIEFS

USSR, PRC SIGN RADIO, TV AGREEMENT--The Soviet State Committee for Television and Radio Broadcasting and the Chinese Ministry of Radio, Cinema, and Television signed a 1987-88 protocol on cooperation. According to the protocol, the two countries will exchange television and radio programs and films, as well as broadcasting personnel, and relay live each other's television and radio programs. [Text] [Moscow in Mandarin to China 1500 GMT 22 May 87 OW] /9274

CSO: 5500/1045

## EEC ANNOUNCES MOBILE TELEPHONE PLANS

Brussels EC INFORMATION MEMO in French No P-6 Feb 87 pp 1-4

[Article: "The Mobile Telephone: A Revolutionary New Generation For All of Europe Starting in 1991"]

[Text] As of 1990 the 12 EC member states are to earmark specific radio frequencies to the second generation of mobile telephones, based on the digital system, which should be in service in the Community and its neighboring countries starting in 1991.

Time is short: By the end of 1987 various technical decisions will have to be made.

This is the essence of a double proposal which the Commission hopes will be quickly adopted by the governments of the EC states.

The digital mobile telephone should progressively replace current equipment, which, according to experts, will develop saturation problems by 1990. The Commission's proposal aims primarily at developing a revolutionary new system which should put an end to the present incompatibility of the various systems, on the one hand, and allow the user to benefit from many new services accompanying the introduction of the "integrated services digital network" (viz. the marriage of telecommunications and data processing), on the other. Indeed, in the future the new generation mobile phone will provide not only voice transmission, but also data transfer, possible access to data and to special services such as caller identification, bulletin boards, scrambling, and rates charged for various types of communication.

Today's Situation: Inconvenient and Expensive

Today there are fewer than 150,000 mobile phones based on conventional technology in the Community. Their number is expected to reach some 2.5 million in 1995, including second generation mobile phones.

The world market for mobile telephone equipment is expected to reach over 7 billion ECU's by the mid-1990's.

In order to establish itself within this specific communications sector, Europe must first clear a hurdle and then make a leap in quality.

The hurdle: The existing incompatibility of five systems using three different frequencies in the UK, Denmark, the FRG, Italy, and France poses two disadvantages:

- In 1987, mobile phone users (sales representatives, small business managers, truck drivers, etc.) see their calls abruptly end at a country's borders;
- The price of the equipment is still too high and extremely varied: The average price ranges from 1,800 ECU's in Denmark to over 6,500 ECU's in the FRG.

Furthermore, even with possible technical improvements, experts are almost unanimous in claiming that the present mobile telephone will very soon--by the early 1990's--reach saturation. In some of the major urban areas of the Community, local saturation problems could occur even before the 1990's.

The leap in quality: In order to progress from today's compatible systems to public mobile communications covering Europe, the commission asks member states, first, to strictly reserve specific frequencies (see appended data sheet) through binding legislation (a directive), and, second, to urge governments, telecommunications authorities, and industry to jointly pursue a series of practical recommendations in accordance with a specific timetable.

This does not imply a leap into the unknown since the goals proposed by the European Commission have already been widely agreed to by manufacturers, PTT authorities, and representatives of the CEPT [European Conference of Postal and Telecommunications Offices]. Their comments indicate that the new mobile telephone generation should use the 900 MHz waveband and that services should be based on digital technology. Furthermore, politics compel us to recall the fact that the European Council, meeting in London on 5 and 6 December 1986, asked that a special effort be made to develop a compatible digital mobile telephone system in the 1990's.

#### The Digital Mobile Telephone: Many Advantages

Such a system, used throughout Europe, offers many advantages:

- Crossborder communication will be possible;
- A unified European market will provide economies of scale and reduce equipment costs;
- A digital system will make it possible for the mobile telephone to be connected to the future broadband telecommunications network offering a vast number of new services;
- The digital system will ensure better quality and more efficient equipment.

Experts generally believe that by the mid-1990's future mobile telephones will cost from 450 to 1,600 ECU's: In other words, the most expensive equipment in 1995 will cost less than...the least expensive mobile telephone in 1987!

Technical Data Sheet

---

Frequencies Used

<u>System</u>	<u>Country</u>	<u>Frequencies (MHz)</u>
1. TACS (3)	United Kingdom Ireland (*)	890-905
2. NMT 450	Denmark (1) Spain (2)	453-457.5
NMT 900	Denmark (1) Switzerland (*)	890-900
3. C-450	FRG	451.3-455.75
4. Ital-450	Italy Portugal (*)	460-465
5. Radiocom 2000	France	+/- 160

---

(\*) Not yet operational, but planned

(1) This system is also used in the other Scandinavian countries

(2) Spain is currently using a variant of the NMT-450 system

(3) TACS is a system derived from the American AMPS system

Proposed Frequencies

In its draft directive the European Commission provides for the following frequencies:

- 905-914 MHz and 950-959 MHz available by 1 January 1991
- 890-915 MHz and 935-960 MHz available for a period of 10 years, to begin no later than 1 January 1991

In addition to a 1991 target date for the introduction of the digital mobile telephone, the commission also proposes in its recommendation:

- Coverage of the major urban centers by 1993;
- Coverage of the major links between large urban centers by 1995.

25024/9835  
CSO: 5500/A030

## MINISTER PROPOSES COMPREHENSIVE BROADCASTING SYSTEM REFORM

Copenhagen AKTUELT in Danish 10 Apr 87 pp 10-11

[Article by Culture Minister H.P. Clausen: "From the Media Policy Viewpoint"; first paragraph is AKTUELT introduction]

[Text] The culture minister provides a picture of a media policy situation in which the hybrid net, TV 2 and the reorganization of Radio Denmark's form of management are the most important elements.

The discussion regarding this year's media policy initiatives has an understandable tendency to concentrate on individual questions. This scattered debate has resulted in the fact that the coherence that is really present in the media policy framework is all too easily overlooked.

The first initiative was liberalization of the rules regarding the reception of foreign TV. Cable developments with a more longterm information technology perspective were begun at the same time.

It is still my conviction that this development is an important element in our society's adaptation to the conditions of the future. The development of the hybrid net will extend over a longer period of time than assumed, but the goal will certainly be fulfilled. The most important thing is that we guarantee at any time the freest possible access to the media possibilities which exist.

The next initiative was the development of a TV 2. Of course, with TV 2 we are aiming at the direct effect of getting increased Danish TV offerings as well as the opportunity for the entire population to choose between several national programs, especially in the news field.

But TV 2 also has an indirect effect, i.e., a competition situation which will have a beneficial effect on Radio Denmark. There is reason to believe that the very difficult process of reorganizing for a changed media situation an institution with over 3000 staff members received a valuable push via the decision concerning a TV 2. But this adjustment presupposes a reform of Radio Denmark's management situation.

We will maintain Radio Denmark as a socially committed institution which will guarantee the entire population a great many all-round radio and TV offerings.

Radio Denmark will continue to attend to duties of essential importance to Danish cultural life.

Its relationship to TV 2 is of a somewhat different nature. The two channels are different with respect to management and establishment structure, and there are also, of course, differences with respect to plane of development and resources.

But TV 2 was created, in the same way as Radio Denmark, as a socially committed element of Danish media offerings. It is a question of an alternative to Radio Denmark rather than of a competitor in the ordinary sense. Together the two channels will constitute the dynamic Danish countermove to international program offerings.

The most important thing is that Radio Denmark will be made more energetic. This goal will be reached primarily by the Radio Council's being replaced by a smaller board of directors which will be appointed mainly by the Folketing. But the more direct day-to-day political influence will be reduced by the fact that Folketing members, according to the proposal, will not be able to be members of the board of directors.

There is need for the distinct distribution of authority at several levels. In part within the institution, and in part with regard to the agencies which attend to duties relating to the institution's activities, i.e., the Folketing and the Culture Ministry.

The Folketing's role in relation to the institution, according to the proposal, will correspond to the present system. It will still be the Finance Committee which will approve the size of the license fee.

It is the same role which the Finance Committee will have in relation to TV 2's finances. This is a natural consequence of the fact that both channels are publicly committed channels, and that they are both elements of a united media policy campaign.

It is precisely for this reason that it will be awkward if Folketing members have seats on Radio Denmark's board of directors. Folketing members must be free in the Folketing when they have to take a stand on funds for the two media institutions, and the two boards of directors must be free when they each individually present their budgets to the minister and Finance Committee.

If Folketing members sit on one of the two boards of directors--and the law already says that they cannot be on TV 2's board of directors--it will mean that Radio Denmark's board of directors will hold a unique position in appropriation matters. This is not satisfactory for the balance the Finance Committee must ensure in the total public media picture.

The Culture Ministry's financial control in the future will be first and foremost budget control. With this the door will be opened for new growth within Radio Denmark and for the changes in activities which doubtlessly will be necessary. For one thing, the basis will be created for Radio Denmark's being able to launch other activities than broadcasting activities per se.



With this the institution will be able to earn income over and above the license fee.

In addition, the proposal emphasizes that the board's of directors responsibility is of a senior nature. The responsibility for daily administrative and financial management lies with the operations management.

In order to guarantee the necessary broader debate regarding the institution's programming activities, according to the proposal a so-called program council is to be established with the affected organizations represented. Listener and viewer organizations will hold seats here of course.

Doubt has been raised regarding to what extent the proposed program council will have real influence, so that the critical function that the Radio Council has today will be weakened. I do not share these misgivings.

A program council which lives up to its obligations will form a very suitable forum for a broad debate regarding Radio Denmark's programming activities. The separation of the board's of directors function and the broad program debate will also eliminate the factor which today often makes management the staff members' advocate before the Radio Council. It will also strengthen the program council's forcefulness.

In the area of local radio and TV, we are facing the final conclusion of the experimental period for local TV. There has been no political doubt that the experimental period should be succeeded by a permanent arrangement.

Now that we have the possibility of seeing local radio and TV together legislationwise, we have found that the time has come to correct one weakness of the previously enacted local radio arrangement. We think that the dailies must have their natural place in new electronic media developments.

It seems unfair to cut certain specific media off from using a particular distribution technique. For there is certainly not talk of anything else in the electronics field.

We think that the risk of local opinion monopolies is very slight. A decentralized decision-making process is being developed which should create a good basis for avoiding such situations.

Finally, then, there is the financing question. The government has made no secret of the fact that we believe in principle that advertising ought to be a natural source of financing for local radio and television operations.

It is only in this way that we will be able to avoid imbalance in relation to those firms which can draw on the funds of large organizations. It is only in this way that we will get the equality of the media which will create proper conditions for competition between the individual types of media. But on the other hand we have admitted that at the present time there is not a political majority for such a solution.

On the other hand, neither does the proposal mean that it will be possible for the State to come in with subsidy arrangements in this area. Should the occasion arise, it must be the local authorities which will be in charge of any financial contributions to projects in the area in question.

I think that it would be dangerous to intervene in media development via a State contribution in this economic sector, and it is my hope that ultimately there will be broad sympathy for the fact that ideas regarding such subsidy arrangements must be rejected. Not just for economic reasons, but also on the basis of a general assessment of a free society's media policy needs.

8831

CSO: 5500/2517

## PARLIAMENT TO ALLOW ANTENNAS TO COMPETE WITH HYBRID NET

Parliament, Government Compromise

Copenhagen BERLINGSKE TIDENDE in Danish 28 Mar 87 p 2

[Article by Morten Larsen: "Cities Won Battle Over TV Antennas"]

[Text] After the hybrid net compromise, the telephone companies are concentrating on selling the hybrid net in the cities. The antenna clubs can count on better and less expensive offerings here, because parabolic antennas have now been set free. Sparsely populated areas, which will have to wait longer for the hybrid net and will probably pay more to be connected, will pay the price.

TV viewers in sparsely populated areas lost and the communal antenna clubs in the cities won with the compromise on the hybrid net which the government and the Social Democratic Party sealed yesterday at the Ministry of Transport.

In the compromise the politicians have bowed to the fact that satellite parabolic antennas and the accompanying receiving equipment have become so inexpensive that they have come within the financial range of the well-heeled man in the street.

It is practically and politically impossible to prohibit them or restrict their use, and therefore all restrictions are being lifted, so that anyone who wants to can put a parabolic antenna on his roof. The only prerequisites are that the antenna be approved with regard to type, that permission be applied for, and that a fee be paid for the Postal and Telegraph Service's paperwork (400 kroner today).

As a result of the liberalization, the politicians have had to change the rules of the game for the hybrid net.

## More Difficult for Hybrid Net

The expansion plans of up to now assumed that the telephone companies through the hybrid net had a monopoly on TV signals from communications satellites. Elimination of the monopoly makes it more difficult for the hybrid net to

compete for the TV viewers' favor, and therefore the government and the Social Democratic Party have made two decisions:

#### Less Expensive Programs

The telephone companies have gotten out of the obligation of having the hybrid net's 24 channels carried out to central distribution points in all of the country's municipalities in 1991. Instead, up to 1 January 1989 they can concentrate on the lucrative heavily populated areas and take care of sparsely populated areas as the economy permits.

The politicians are relaxing the narrow limits for the fixing of rates by the telephone companies. These limits were introduced at one time in order to ensure a certain degree of rate equalization between city and country. In the future the telephone companies will have free rein to agree with customers as to how many programs they want to take, and to offer quantity discounts and discounts on individual programs, so that the hybrid net's satellite programs can compete with what it costs an antenna club to put up its own parabolic antenna.

For sparsely populated areas, this will probably mean that it will be longer before the hybrid net reaches them, and that it will be more expensive to connect up to it than it would have been otherwise. Neither Transport Minister Frode Nor Christensen (Democratic Center), Culture Minister H.P. Clausen (Conservative Party), nor the Social Democrats dare to predict how much.

On the other hand, the future looks brighter for the antenna clubs in larger urban areas, when the necessary changes to the broadcasting legislation are adopted in the course of the spring. With their private parabolic antennas as a backup, they will be in a stronger position in negotiations concerning rates with the telephone companies, and the more programs from neighboring countries they can receive with their own antennas, the less expensive the rates for these programs will be. In addition there is the possibility of quantity discounts if they buy many channels.

#### Wideband Net to Be Developed

It is still the politicians' stated resolution that the hybrid net must pay for itself. Even if its development will presumably extend over several years, it must not require subsidies either from the taxpayers or telephone users.

The problem for the politicians in this connection has been the fact that the hybrid net was intended to be the driving force in the development of a net of optical fiber cables for data communications for industry.

This so-called wideband net will not be held up, but will be developed to the extent that any firm, institution or private individual whatsoever will be able to ask to be connected to it with a maximum of three months' notice from and including the year 1992.

## Freedom to Say No

In order to guarantee its development, it has been separated from the hybrid net and transferred to the telephone companies' general investments for the future. With this, the telephone companies can send the bills to the users if industry does not join the hybrid net at the pace the politicians have presumed.

The agreement between the Social Democratic Party and the government also has a cultural policy aspect. The users of a communal antenna facility which is not owned by the users themselves are to have an influence on what the programs are to be, and to have the freedom to say no to the offer, the culture minister reported. In addition, the transport minister will develop recommended guidelines for antenna clubs which guarantee that, when members are to choose between channels by voting, it will take place in accordance with methods which protect minorities.

"It must not be the case that 51 percent of the members of a club decide what the remaining 49 percent are to see," H.P. Clausen says.

Finally, it has been stated that all communal antenna facilities are to accommodate both Radio Denmark's television offerings and the new TV-2. In addition, one of the channels is to carry local television programs if the antenna facility has nine or more channels.

### 25 Channels Via Antennas

Copenhagen BERLINGSKE TIDENDE in Danish 28 Mar 87 p 2

[Article by Jan Jorgensen: "Twenty-Five TV Channels in the Air"]

[Text] The private parabolic antenna in the back yard at home can deliver 20 to 25 TV channels--but it is permissible to peek at only three of them. To peek at the others is eavesdropping.

Such is the situation after the government and the Social Democratic Party yesterday opened the door to the sale and erection of parabolic antennas for the reception of TV programs from satellites.

That there are only three one can look at is associated with the fact that the suppliers of the TV programs must approve their reception here in Denmark, and only three of the satellite TV stations have done this as yet.

The supply of TV programs is almost countless, but if one takes the most popular of the satellites--called ESC-1--then, for a price of between 11,000 and 15,000 kroner for a parabolic antenna, one gets the following nine TV programs:

Teleclub, a film channel from Switzerland.

Superchannel, English entertainment.

RTL Plus, entertainment from Luxembourg.

TV-5, French TV station.

RAI, Italian state-owned television.

SAT 1, German commercial channel.

3-SAT, cooperative effort between Austria, West Germany and Switzerland.

Sky-channel, English entertainment.

Filmnet, private commercial channel.

The last two channels are encoded, and it is necessary to have a special decoder in return for a monthly fee.

Of the seven which are freely accessible, it is permissible to view only Superchannel and TV-5. The third one which can be viewed legally is Sky-channel, but it is encoded and costs a monthly fee to view.

#### Hybrid Net Costs Cited

Copenhagen BERLINGSKE TIDENDE in Danish 30 Mar 87 p 2

[Article by Morten Pihl: "Hybrid Menu Too Expensive for Danes"]

[Text] The politicians are taking exception to scathing criticism of their planning of the hybrid net. Adjustment of the project was necessary. All firms can be connected to optical fiber cables in 1991 at the latest.

The Social Democratic Party's chief negotiator for the hybrid net, Poul Erik Korneliusen, refutes a number of media researchers' scathing criticism of the planning of the hybrid net.

He admits that the telephone companies and the politicians overestimated the viewers' interest and desire to pay for more TV programs when the government and Social Democratic Party entered into the agreement concerning the hybrid net in 1984. But he denies that the sides' adjustment last Friday--the one that gives each and everyone the right to receive satellite signals with parabolic antennas--gave the deathblow to the hybrid net.

"On the contrary, we said that every firm in the country will be able to be connected to the hybrid net with three months' notice in 1991 at the latest. And with regard to the TV part of the hybrid net, we gave the telephone companies the possibility of competing for the sale of TV programs on an equal footing with private companies. This will mean lower prices," Poul Erik Korneliusen says.

Low Prices Changed the Issue

He thinks that the adjustment was necessary. "In part because of popular pressure, which was caused by developments in our neighboring countries where one is permitted to set up his own parabolic antenna. In part because parabolic antenna equipment has become much less expensive."

"Whereas a parabolic antenna cost 100,000 kroner in 1984, today it costs 10,000 to 20,000 kroner," says Poul Erik Korneliusen. The Social Democratic chief negotiator admits that it was wrong to let the sale of the hybrid net's TV part be the driving force for the nationwide net of optical fiber cables.

"It would be idiotic to deny, but the agreement concerning the hybrid net is correctly completely technology-political. It must be the politicians' duty to look ahead in time. We know already now that a number of large reputable firms have transmission requirements that the existing telephone system cannot handle," Poul Erik Korneliusen says. He will not give the names of the firms.

#### Parabolic Antenna Sales Boom

Copenhagen BERLINGSKE TIDENDE in Danish 1 Apr 87 p 2

[Article by Jan Jorgensen: "Heavy Sales of Parabolic Antennas"]

[Text] Suppliers of parabolic antennas for satellite television report heavy sales after the Folketing's decision that everyone can get permission to set up a parabolic antenna.

The Danes have taken the plunge into parabolic antennas and the many TV channels. Both manufacturers and dealers of parabolic antennas, which can get viewers between 20 and 25 TV channels on their televisions, report overwhelming interest. Last Friday the government and the Social Democratic Party agreed that everyone can receive permission to set up parabolic antennas.

"On Monday and Tuesday we received a few hundred orders for parabolic antennas," says Managing Director Kurt Christiansen of Triax in Horsens, which is the only Danish manufacturer of parabolic antennas. "Things have begun to move now. We still have parabolic antennas in stock, but if sales continue for the next few days we will not be able to keep up."

The Silver Group in Farum sells and leases parabolic antennas. "We cannot keep up. We are receiving a few hundred orders a day. Half want to buy, and the other half to lease," says Managing Director Kim Wunsch.

Parabolic antennas cost from 11,000 up to 25,000 kroner, all depending on how many technical gadgets they are to have. The least expensive model can take a single satellite with nine TV channels.

8831  
CSO: 5500/2485

## NORDISKE KABEL- OG TRAADFABRIKKER EMPHASIZING HIGH TECHNOLOGY

Copenhagen BERLINGSKE TIDENDE in Danish 26 Mar 87 Sect III p 5

[Article by Erik Bendt-Rasmussen: "High Technology Drew Up NKT's Profits"]

[Text] Optical fiber cables and electronics doubled in sales. Net profit increased by 71.5 million kroner to 219.8 million kroner. The domestic construction upturn also contributed to improved profits.

High technology brought the major part of the profit home to Nordiske Kabel- og Traadfabrikker [Nordic Cable and Wire Manufacturers] (NKT) in 1986. Optical fiber cables and electronics made the cash register ring. NKT has for several years invested large sums in new-technology research and development, and now they are beginning to receive money to cover expenses and produce rising profits as well.

The concern's net profit, which is the most important thing to look at in this connection, is 219.8 million kroner (148.3 in 1985) before financial and extraordinary items. The corresponding figures for the parent company are even better, that is, 203 million kroner (118 in 1985).

A couple of months ago NKT ran into a form of dubious advertising, when KTAS's [Copenhagen Telephone Company's] Managing Director Per Ammitzball said that the factory's optical fiber cables are poor and expensive in comparison with foreign ones. There was a big hullabaloo concerning KTAS's managing director, but it ebbed away when it was shown that a mountain had been made out of a molehill.

### 300 Million Kroner Worth of Optical Fiber Cables

It is optical fiber cables for export and the domestic market that added heavily to NKT's earnings. Glass-fiber optical cables are gradually replacing the traditional copper cables.

Regarding the year 1986, it reads as follows in the balance sheet report sent to the Copenhagen Stock Exchange yesterday: "Market trends in Denmark were characterized by a high level of activity in those areas which are of greatest importance for the sale of the concern's products. The growth in construction and business investment especially resulted in a considerable rise in sales."



"Sales of optical fiber cables for telecommunications and the electronics which must be supplied for this doubled. Exports also rose."

BERLINGSKE TIDENDE has learned that sales of optical fiber cables and equipment for them amounted to 300 million kroner in 1986 versus 150 million kroner the year before. This indicates some interest in NKT's products.

According to the balance sheet, 159 million kroner were invested (140 in 1985). Sales rose by 12 percent to 2.4 billion kroner. By the end of the year NKT had 3700 employees versus 3600 the year before.

The concern's profit before taxes was 184.8 million kroner (123.3 in 1985). The parent company has a net profit of 158 million kroner (124 in 1985) at the stockholders' disposal. A 14-percent dividend (12- in 1985), or 35.8 million kroner, is being paid. Seventy-five million kroner are being placed in reserve, and the remainder is being carried over to 1987.

At this time NKT is negotiating, presumably in the concluding phase, with the Indian Hindustan Cables state-owned company, on a 200-million-kroner contract for an optical fiber cable factory.

#### Joint Effort

Last year, besides, NKT entered into an economic arrangement with American Telephone & Telegraph concerning the manufacture of NKT's optical fibers, sales of which are expected to triple. NKT itself will continue to be in charge of optical fiber cable manufacturing.

8831

CSO: 5500/2485

## D2-MAC TO BE TV-STANDARD FOR FRANCE, FRG

Duesseldorf HANDELSBLATT in German 28-29 Mar 87 p 21

[Article: "Television: Future TV-Standard in Europe is Called MAC. First D2-MAC Equipment at Radio Communications Exhibition"]

[Text] Duesseldorf, 28-29 Mar (VWD/WT)--After years of delays the first German direct-broadcasting satellite, the TV-SAT 1, may yet be launched into space before the Berlin Radio Communications Exhibition (28 August to 6 September 1987) and begin broadcasting using the new European TV-standard, D2-MAC. But industry experts doubt whether the necessary terminal equipment, such as satellite receiving equipment, television sets and video recorders with the appropriate decoders, will be ready for series production at that time.

As the result of political decisions concerning the configuration of the new TV-standard, the industry had no basis for development in view of the ever changing objectives. That is why it is difficult at present even to get moving on a MAC-decoder, explains Dr Michael Thiele, press spokesman for Philips GmbH in Hamburg. Nevertheless, he expects that at least the initial "laboratory units for a D2-MAC will be on display" at the industry trade fair in Berlin.

A historical note: In mid-1985 the FRG and France agreed upon the introduction of the D2-MAC standard for satellite television, and on November 3, 1986, the EC agreed to introduce the MAC-family within its member nations over the long term. Their goal is to replace the two color TV-standards used to date in Europe, PAL and SECAM.

Joint development of broadcast satellites, which led to the construction of TV-SAT 1 (FRG) and TDF 1 (France), was agreed upon as early as five years before. From a common orbit each of the satellites was to broadcast five channels of TV and radio programming throughout Europe using digital technology. According to the international media agreement to be signed on April 3, 1987, concerning the reorganization of the broadcasting system, the TV-SAT channels will be allocated to the private networks, ARD and ZDF.

## D2-MAC Offers Clean Separation of Picture and Sound

However, even within the industry there is doubt about whether the expenditures for the new D2-MAC TV-standard will produce correspondingly high picture quality. It is said that a "substantial" improvement in picture quality of approximately a factor of two cannot be achieved with the new standard because it uses the same picture criteria as the current PAL/SECAM standard--625 scanning lines per picture and 50 Hz frame frequency. In addition, MAC lacks a crucial option in terms of ensuring its future, namely that of modification for 60-Hz frequency as commonly used in Japan and the United States.

There are, however, two undeniable advantages to the new TV standard: Because of the clean separation of picture and sound in the transmission process, the so-called Cross-Coller effect is eliminated. The new standard therefore allows superimposed lettering, for example, to be clearly outlined against the background. Moreover, the principle used in D2-MAC, which is comparable to a digital process, produces no "washed-out" pictures: The TV picture can either be received perfectly or not at all.

For areas with cable, the West German Bundespost will reconvert the D2-MAC signal to the PAL standard and then feed it into the cable system. Within a smaller part of the cable area, the D2-MAC signal will be offered additionally on the cable. Technical experts doubt, however, whether the channel pattern selected for this purpose will allow improvements in picture sharpness.

Although private satellite dishes installed to date--"officially" numbering about 1000 according to the Bundespost--are not immediately compatible with the TV-SAT 1 because of their different transmission technology, the Bundespost is allowing receiver systems for this direct-broadcasting satellite even within areas with cable. Due to the high transmitter power, dish diameters of 60 to 90 cm are adequate.

In view of the fact that the TV picture using the new D2-MAC standard will nevertheless be a few percent better than the current standard, there are worries about how the slight difference can be made appealing to buyers of new TV sets or appropriate decoders. At the same time the experts point to high-definition television (HDTV) which will be able to be broadcast via satellite in the future. With HDTV the TV picture will comprise 1125 scanning lines or nearly double the amount used by the current TV standard.

The argument is valid in that the MAC standard in particular offers a distinct advantage with respect to the introduction of high-definition TV. Compared to the Japanese standard it is designed to permit conversion to an HD-MAC without major complications. Compatibility would also be provided within the MAC standard for the introduction of high-definition television. This means that HD-MAC transmissions could also be received by a normal D2-MAC unit, according to Philips spokesman, Mr Thiele.

Although the scope of the HDTV studio equipment being installed and the number of films being produced is extensive, it will nevertheless be several years before HDTV is on the market. Which HDTV standard will be introduced is still an open question. The EC, at a meeting of the International Broadcasting

Council in May 1986, prevailed in delaying a European decision in favor of the Japanese NHK production standard for two years.

A strictly European standard is being promoted, such as that expected within the EUREKA research project during the next four years. There is substantial participation in this project by Thomson of France, Philips of the Netherlands, Thorn/Emi of Britain and the Bosch group of the FRG. They want to maintain the 50-Hz frame frequency and double the number of scanning lines to 1250.



China, a trade partner at the industrial trade fair in Hanover, is also involved in the satellite business. Chinese exhibitors will display a mockup of a communications satellite at the Hanover Trade Fair (April 1 - 8). The Europeans, in the meantime, are still having difficulty launching their first direct-broadcasting satellite, TV-SAT 1, into space. The launch has been delayed for years. At present hardly any of the experts can give even an approximate launch date for this year. The new satellite is the focal point of efforts to introduce the new TV-standard, D2-MAC, in France and the FRG.

## PLANS, DESIGN, EQUIPMENT FOR ISDN NETWORK THROUGH 1988

Paris FRANCE TELECOM in French Feb 87 pp 25-33

[Article by Jacques Guitonneau: "Objective ISDN"]

[Excerpts] Digitization: The French Lead

The digitization of switches and transmission systems is one of France's strong points. France pioneered this field in the early 1970's with the E10 communication system. Today, figures speak for themselves. Digitization involves 70 percent of the junctions and local circuits, 50 percent of the trunk circuits, 50 percent of the switches to which users are connected, and 60 percent of the transit exchanges. This mutation is proceeding at a fast pace, so that the network will be fully digitized before the year 2000. Some components, such as trunk transit exchanges, will be digitized already in the early 1990's. As a comparison, the other industrialized countries are targeting much later dates: 2010, even 2030.

Already now, all users' digital exchanges can be connected to one another through purely digital channels. Thus, switched 64-kbit/s links are available throughout the country. This is achieved without any undue additional cost, without having to operate a special network, and without any incidence on telephone traffic.

#### Setting our Clocks

The second stage will consist in network synchronization. With time-division technology, it is obviously essential to measure time accurately. Each switch has its own clock, with a precision of  $10^{-6}$  (i.e. an error margin of 3 seconds per month). In other words, some clocks are imperceptibly faster than others and eventually the exchanges are out of phase with one another. On the average, a shift occurs every other minute.

Such a shift is absolutely unnoticeable in a telephone communication. But digital services are more demanding. When it comes to data, each byte counts and any frequency shift between network nodes will cause unacceptable repetitions or losses.

To ensure transmission integrity, the clocks of the switches had to be controlled by frequency references. Thus, each exchange must be equipped with a special unit designed to receive synchronization links. These links are distributed gradually according to the network hierarchy, from very-high-precision atomic clocks (10-11).

The synchronization operation launched back in 1982 is expected to be completed by mid-1987.

#### Enhanced Signalling

Third stage: enhanced signalling. It will make it possible to offer additional services such as caller identification, already mentioned, or to select directly one of several terminal connected to the same main line, or to move the telephone from one jack to another during a call without being cut off, etc.

Enhanced signalling will comply with an international standardized code: CCITT 7 (box p 29). Its principle is based on the use of data-transmission links dedicated to signalling, which are called semaphore channels. In addition, its structure is quite open and provides for large and fast data transfers between switches. While the part concerning ISDN services has not been entirely defined yet, the main rules concerning traditional telephony, on the other hand, were set already in 1980.

Based on this, time-division switches could be adapted to CCITT 7. Experiments started in 1985 and implementation in the network will start early in 1987. All E10B, E12 and E10-MT exchanges in service will be converted to Code-7 standards by the early 1990's. Priority will be given to transit exchanges and to the Paris, Lyons and Marseilles urban areas. Considering the high proportion of digital switches in the network, Code 7 should concern over 40 percent of all circuits in 1990, and 70 percent in 1995.

Even limited (at first) to traditional telephone signalling, Code 7 is a major progress. It will considerably improve service quality, for instance by reducing to a few seconds the waiting time after dialling. Later on, a mere addition of software to the exchanges will suffice in practice to adapt signalling to the latest ISDN stage: service enhancement with the introduction of ISDN ports.

#### Connection: Retaining the Existing Infrastructure

The user connection is the "terminal" part of the network, the part which connects the user's installation to its exchange switch. It is provided by transport and distribution networks which will finely innervate the national territory, requiring a considerable length of cables.

Replacing the existing transport and distribution cables would therefore be very expensive. The expenditure would be all the more regrettable as the French network is recent and its infrastructures in good condition. Yet, distribution must be digitized if ISDN services are to be offered on a wide scale throughout the country.

How could we digitize and reuse the existing infrastructure? With a new "user's connection unit" (URA). A URA is a piece of switching equipment used to connect users and to concentrate their traffic on a limited number of circuits. It can be installed at the exchange itself, as well as in distant locations so as to bring the switch closer to the users.

Named "CSN" (Digital Satellite Center), the new URA will make it possible to connect analog as well as digital lines. It will offer basic ISDN ports for different transmission modes (alternating, 4-wire, echo cancellation). It could also take the form of distant mixed concentrators (for analog and digital lines). These concentrators will be small enough (250 lines) to be disseminated as close to the user as possible, which will reduce the length of lines remaining to be digitized.

CSN prototypes were ordered already in 1985. They will be installed in series starting in 1987, the goal being to cover most of the country by the early 1990's.

Pending this systematic completion of distribution digitization, users may request individual digital connections to the services already offered. Technically, this can be done in two ways: either a 2-Mbit/s link which may require the installation of a special cable; or a 64-kbit/s "baseband" link (the signal is then transmitted directly without any modulation).

#### A Trend That Has Already Started

The French Telecommunications are now building the framework of the network of the end of the century. The trend started several years ago with Transmic and Telecom 1.

#### Today: Transcom-ISDN

Transcom-ISDN, a 64-kbit/s switched service, opened in March 1986. Its implementation involved changes in the general network as well as specific connections (Figure 4).

As far as the network was concerned, digital routing between users had to be provided from end to end. Transcom calls are therefore "labeled" with a particular access code which causes them to be "switched" to purely digital circuits and switches. Where only analog or mixed circuits existed, digital circuits had to be set up for Transcom-ISDN.

As far as distribution is concerned, the CCITT has planned and is currently developing a standard for a 144-kbit/s line. In the meantime, Transcom-ISDN uses the existing equipment for dedicated 72-kbit/s baseband links (64 kbit/s plus 8 kbit/s for signalling). This line is connected:

- at the switch end, to an "URCN" multiplexer (Digital Circuit Connecting Unit). This URCN can multiplex up to 30 digital lines on a 2-Mbit/s connection and can be connected to any time-division switch.

- at the user's end, to Transcom control equipment integrating the modem and the standard interface ("X21" or "V35").

Subject to being transparent, the PABX connected by 2-Mbit/s links (there were 260 of them at the end of 1985) can access Transcom directly.

Transcom-ISDN, therefore, represents an important first stage as well as a full-scale test of network quality leading to subsequent stages. Already, it provides a significant gain to users since its bit transmission cost is seven times lower than through analog channels. Users are not indifferent to this argument, and this is reflected in the number of projected connections: about 100 at the beginning of 1987, close to 2,000 by the end of 1988.

#### The Post-1988 Era

After Transcom-ISDN, additional functionalities will still have to be implemented to reach the second generation. This will require that switches be equipped with the previously described ports: (30 B + 1 D at 64 kbit/s). Enhanced signalling carried by the D channel will considerably expand the range of potential services.

#### The Advantages of Enhanced Signalling

A single standardized interface, called "S," will be used for all terminals. Currently under development, it will be available by mid-1989 for both types of ports and switches (E10B and E10-MT).

What are the services that will then be offered? Let us take three examples.

First, transmission of the caller's directory number to the person called. Thus, emergency services will immediately know the origin of a call, even if the caller is unable to indicate where he is. Or, a private exchange will be able to switch the calls directly according to their origin (internal or external to the company). The same exchange could also filter the calls made to certain terminals which support "sensitive" applications.

Second example: Code-7 signalling could carry a two-digit "subaddress" after the number dialled. Many different terminals could thus be connected to a single digital line, each of which would be identified by its subaddress. It will no longer be necessary to require assignment of a special telephone number for each new piece of equipment.

Finally, user-to-user signalling: even before picking up the phone, the person called will be able to receive a 32-character message and to store it into the memory of his terminal. This signalling will fulfill some of the functions of an answerer-recorder: call filtering, directory of calls received, messages left by callers.

#### Testing Equipment and Services

To implement these services, it will not be enough to adapt switches. Specific equipment will also have to be introduced: simple or complex user's



control equipment, S-interface terminals such the future digital telephone station, adapters enabling ISDN operation on existing terminals and services (Figure 5 [not reproduced]).

All this required testing before general use on the network. This is one of the goals of the Renan operation (which will also attempt to test users' receptivity to this new line of products). It will start in 1988 in three locations in Cotes-du-Nord and Ille-et-Vilaine, before being extended, later in the year, to several locations in the Paris area (Figure 6).

Around mid-1989, Renan will have taught all its lessons and the equipment will have gone from the prototype stage to the industrial production stage. The introduction of ISDN functions into all E10B and E10-MT exchanges will then begin, according to the demand. A large proportion of the country will soon be covered and, already at the start of the 1990's, the Telecommunications will be able to offer a wide range of digital services.

It will then be the turn of terminal and service suppliers to play: they are now showing their desire to follow this trend, on which the success of the ISDN depends as, without them, it would remain an empty shell.

[Box, p 29]

#### CCITT Code-7 Signalling

On the traditional telephone network, the signals used to put calls through are transmitted on the same circuits as voice signals and limited to the essential: number of the person called, busy signal, etc. On the contrary, in the ISDN, a channel called "semaphore" is specially assigned to signalling for a series of voice circuits. This channel makes it possible to transmit additional information, for instance the caller's number.

The CCITT (International Telegraph and Telephone Consultative Committee) defined Code 7 that will be used on the semaphore channel. The code complies with the "open system interconnection" model (OSI in English) defined by the ISO, an international standardization organization, and now adopted by all manufacturers. The OSI describes a seven-layer architecture in which each layer communicates with its neighbors only through specific standardized interfaces. The first four layers deal with data transmission, the last three with the use made of the data. In practice, Code 7 was defined in four levels, the first three corresponding to the lower layers of the OSI model.

The first layer corresponds to the physical link. For the semaphore channel, France has adopted a 64-kbit/s link.

The second layer will check transmission accuracy. For the semaphore channel, a special raster format and security transmission procedures were defined. Errors are detected by the the polynomial method and the messages transmitted again if they are not correct.

The third layer is designed to route data to the correct address. A routing label is therefore added to the message. It indicates its origin, destination

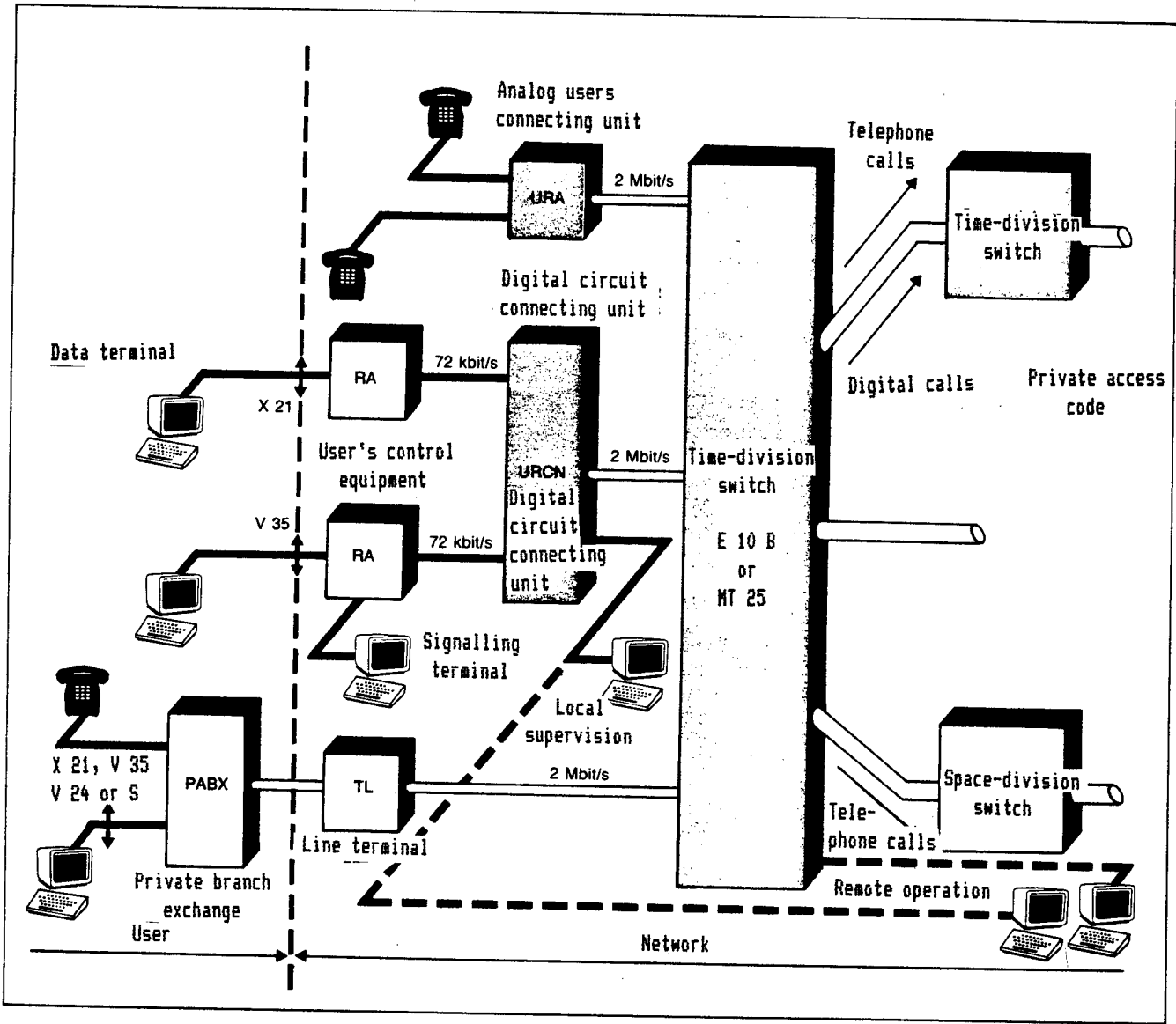

(CENTER) Figure 4 - Structure of the 64-kbit/s Switched Telephone Network

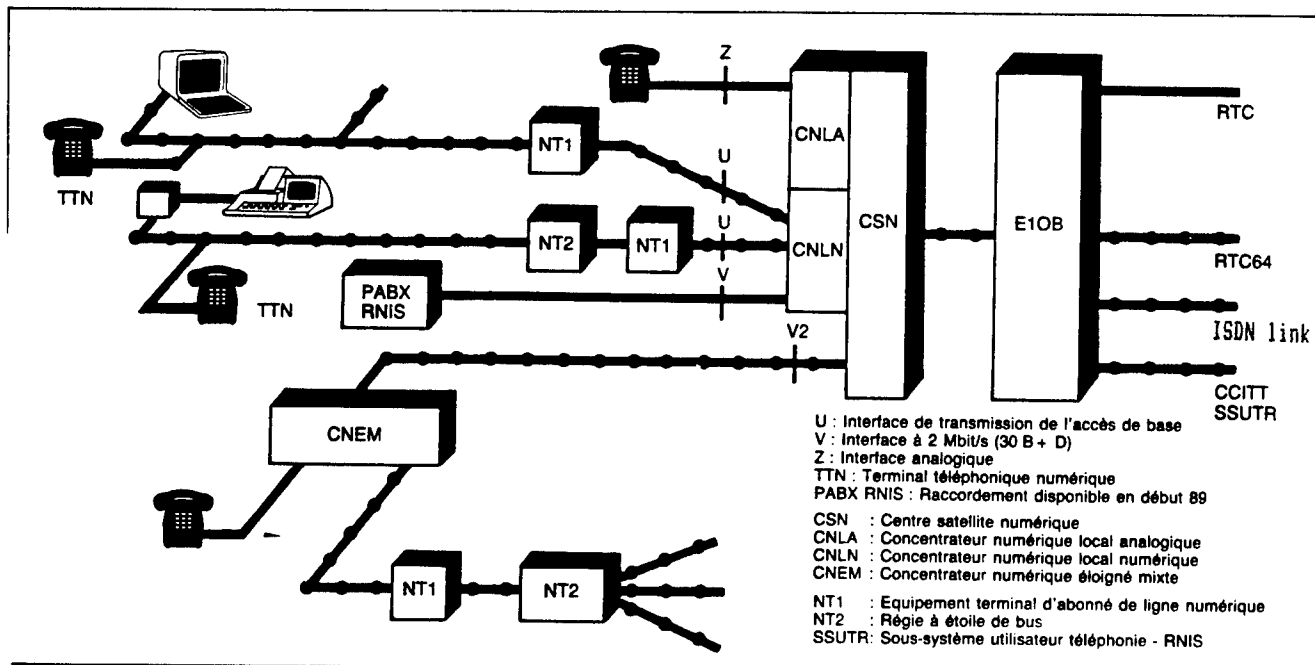

(CENTER) Figure 6 - Network Architecture Used for the Renan Operation

- Key:
- U      Transmission interface of the basic port
  - V      2-Mbit/s interface (30 B + D)
  - Z      Analog interface
  - TTN    Digital telephone terminal
  - PABX RNIS [PABX ISDN] Connection available early in 1989
  
  - CSN    Digital satellite center
  - CNLA   Analog local digital concentrator
  - CNLN   Digital local digital concentrator
  - CNEM   Mixed distant digital concentrator
  
  - NT1    Terminal equipment of digital line user
  - NT2    Bus star configuration control equipment
  - SSUTR ISDN-telephone user subsystem

and the channel to be used for signalling. Actually, signalling can use specific circuits and message switches (semaphore transfer points) which are independent of the circuit group to which it refers.

The fourth level of CCITT Code 7 corresponds to the upper layers of the OSI model (layers 4 to 7). It describes the various procedures used by telephony, the many ISDN services, operation and maintenance tasks, data exchange between switches and servers, etc.

The introduction of Code 7 will require the implementation of a veritable signalling network that will need a high level of protection and security (doubling of the semaphore channels, transmission security, duplication and full meshing of signal transfer points, etc.). On the other hand, the code flexibility (allowing in particular for variable message lengths), will make it possible to introduce all ISDN functionalities progressively, by adapting software and switches.

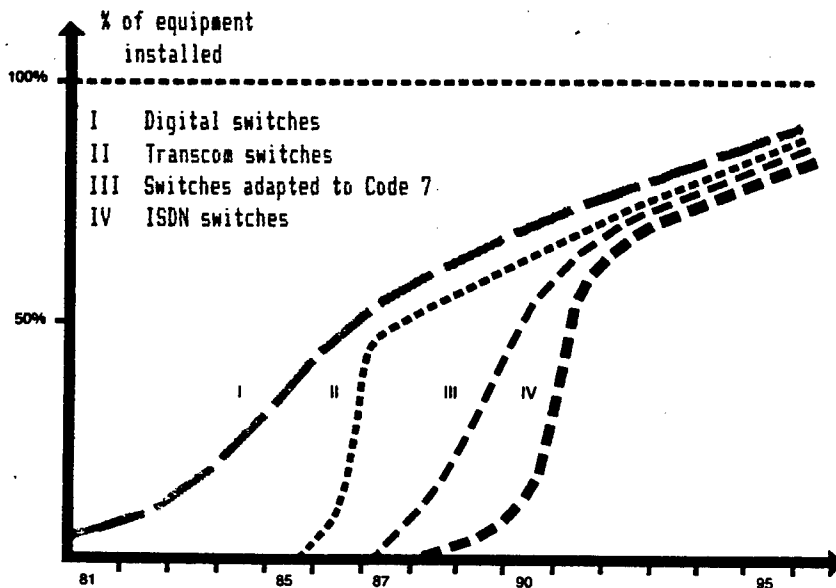

(CENTER) Figure 7 - Evolution of French Switches Toward ISDN

9294

CSO: 5500/2498

## BRIEFS

NEW FRENCH NEWS RADIO--On Monday, 1 June, there will be a new radio station on the air, France Info. It will broadcast in Paris, Lyon, Marseilles, Toulouse, le Mans, Mulhouse, Clermont-Ferrand, and Nantes on 105.5 on frequency modulation, and will be devoted entirely to news. Initially the station will broadcast from 0500 GMT to 2200 GMT, but it is hoped that it will eventually broadcast from 0400 GMT to 2300 GMT. In an interview with Paris Radio Jerome Bellay, the editorial director of Paris Radio, who also masterminded the new station, said that there will be news bulletins lasting about 7 minutes, updated every hour and half-hour. Whenever there is an urgent story it will be broadcast immediately, like for example with the tennis results in the French Open tournament. The aim was not to have a station which is listened to all the time, but rather to be like American news stations which listeners tune-in to for around 15 minutes. It's role, he said, is to complement other radios, like Paris Radio. There will be modules of half-an-hour each which will give updated news bulletins, weather and road reports, sports, racing, entertainment and so forth. It is not envisaged that France Info will be a competitor for Paris Radio, but rather, complement it, he said. France Info will give short news bulletins, while Paris Radio will continue to have proper programs, with more in-depth news, interviews. It will have a very experienced staff many of whom have or still do work for Paris Radio. It will be the most advanced radio station from a technical point of view, with computerized dispatches coming up on a screen. [Summary] [Paris Domestic Service in French 1100 GMT 29 May 87 LD] /12858

CSO: 5500/2519

## ERICSSON BECOMES WHOLE OWNER OF INTELTA

Stockholm SVENSKA DAGBLADET in Swedish 14 Apr 87 p IV

[Article by Willy Silberstein: "Ericsson Takes Over Intelta"]

[Text] Ericsson has become the whole owner of the Spanish telecommunications company Intelta by taking over the Spanish telecommunications administration's part ownership.

For some time Ericsson has owned 51 percent of Intelta shares and Spain's telecommunications administration Telefonica has owned the remaining 49.

Some time ago Telefonica started to go in a different direction. This meant that Telefonica is reducing its industrial activity and concentrating on managing telecommunications. For that reason Telefonica has begun to sell off companies.

## Small Differences

"We were pleased to have Telefonica as a part-owner. But we of course accept the new direction and will become the whole owner ourselves," said Hans Golteus, marketing manager of Ericsson Telecom. As Ericsson sees it, the actual differences will not be great.

Intelta manufactures primarily AXE switches and the MD 110 private market switch. The firm has approximately 40 percent of the Spanish market for public switches.

Some production of communications equipment will also happen. Most of it goes to the Spanish armed forces, but some Latin American nations are also on the customer list.

## Cash Payment

Intelta is selling approximately 800 million Swedish kronor and the profits last year were 70 million. The firm employs 2,400 people.

Ericsson will not say how big the purchase price was. The payment is in cash, so there was no question of bringing the Spanish telecommunications

administration in as a part owner in Ericsson in connection with this deal.

Part ownership with both the Spanish and the Italian telecommunications administrations may, however, still come about. Ericsson has had discussions about allowing Spanish and Italian interests to purchase between five and ten percent of the stock each.

#### Giants On The Market

Among the deal's background factors are huge development and marketing expenses for the telecommunications side. In the future Ericsson may find it difficult to compete with the giants who have been founded on the market.

Ericsson is also discussing with Spain taking over the ITT-owned Marconi which manufactures defense electronics. Ericsson itself has not shown interest in the firm but has rather been courted by Spain, which is concerned that Marconi will cut the number of employees and thus increase unemployment problems.

"We are prepared to take over Marconi if it happens for sound economic reasons, so the firm can stay profitable," said Golteus.

12789

CSO: 5500/2504

## ERICSSON BUYS 20 PERCENT OF FRENCH CGCT

Stockholm SVENSKA DAGBLADET in Swedish 24 Apr 87 Pt 3, p 1

[Article by Ewa Hedlund and Christer Hedberg: "American Protests After Ericsson's French Victory"; first paragraph is introduction]

[Text] Paris (SVENSKA DAGBLADET)--Ericsson finally won the fight over CGCT, the French telecommunications company. The French government's decision to allow Ericsson to buy into the state-owned CGCT provoked immediate protests from the USA, which had worked intensively so American AT&T could land the deal and get a foothold in the European telephone market.

"Americans are litigation specialists," said Hans Werthen, the company's executive president, who does not believe the American protest will have any negative aftereffects on Ericsson's activity in the US.

Hans Werthen also thinks it is heartening that Ericsson has won the battle against companies as important as AT&T and Siemens. He thinks a decisive factor behind Ericsson's victory in the fight is the 900,000 analog AXE lines the firm had installed in France as of 1984.

"Certainly other models were under consideration, but the French know that the quality of our switches is good," Hans Werthen said.

#### Politically Sensitive

Yesterday at 0830 hours French Finance Minister Edward Balladur announced the following about one of the most discussed and politically sensitive deals in many years:

"We are selling 20 percent of CGCT, the state-owned telecommunications company, to Ericsson."

The French government had three requirements of those firms who were competing to buy into CGCT, the Compagnie Generale de Constructions Telephoniques:

the firm needed to make a good product;

the firm needed to show an industrial and technical interest in France;



the firm needed good economic qualifications to manage the deal.

"Ericsson's offer was the only one that satisfied all three conditions," Edward Balladur said. "Ericsson has a communications system which is easily adaptable to France. It is the most seasoned and requires the fewest development costs."

The fight over the CGCT has been going on for three years and at the end developed into a political struggle at the very highest levels.

Both the US and West Germany lobbied hard to get their firms, AT&T and Siemens respectively, judged the winner. The Swedish government as well did what it could for Ericsson. For a long while it looked as though AT&T, which had made an offer together with the Dutch firm of Philips, would emerge the winner. But even up till Wednesday evening it was uncertain who would become the CGCT's partner.

In the end, the deal acquired such major political dimensions that the government must have anguished over its decision to allow a Swedish firm onto the French telecommunications market.

But at yesterday morning's press conference, Edward Balladur stated that no political considerations played a role:

"The deal was decided strictly on technical and industrial grounds."

He pointed out at the same time that political influences in this case had been counterproductive.

Ericsson learned it had been chosen on Wednesday evening. The French government had called in Ericsson's managing director, Bjorn Svedberg, for some final details. After his meeting with Edward Balladur, Bjorn Svedberg was so certain of victory that he went out and celebrated the deal with champagne together with Hans Golteus, who conducted the negotiations in recent months.

The American reaction was very sour. The American ambassador to Paris immediately delivered a protest to the French government.

For Ericsson, it is a major prestigious victory to have won over the Siemens and AT&T giants.

"The deal is really important for Ericsson," said Hans Golteus. "France is a major market. It is strategically important since France is a major strategic country in the EC. The deal is also technically significant since France has considerable knowhow which we shall utilize in the development center we'll build in France."

"As the EC becomes a much more unified market as far as data and telecommunications technology is concerned, there is always a risk when you begin to do business inside the bloc. So it's important to be there," said Bjorn Svedberg.

Also of importance in this deal is the fact that Ericsson's base will be expanded further. Now the Swedish telecommunications giant can be a serious major player when the decisive battle for the telecommunications market takes place.

"There will be room for five to six major players in the future, and we will be one of them," Bjorn Svedberg said.

When the contract is signed in a few days, Ericsson in practice will own 26 percent of the shares in the public telephone part of CGCT. Twenty percent are owned directly by Ericsson, 50 percent by Matra, the French state-owned electronics group, Ericsson's main partner in the deal.

A holding company consisting of Ericsson, the French construction company Bouygues and the Banque Indosuez will own the remaining 30 percent. The purchase price was 500 million kronor, split equally among the share holders.

The company, which does not as yet have a name, will become France's second supplier of telecommunications material, telephone switches, telephone sets, material, etc. to the French telecommunications administration DGT. The principal supplier is the French firm Alcatel.

#### Ran At A Loss

For four to five years the CGCT has run at a loss, and Ericsson does not expect a profit for some years.

"The company will need an investment of 100-150 million [kronor] during its first year," Hans Golteus. "After that it will take several years before the company can show a profit."

As a result of the deal Ericsson acquires 16 percent of the French telephone market, which means that the newly-founded company will sell approximately 300,000 new telephone lines per year for about five years with the totally electronic AXE switches. The company will have an annual turnover of 700-750 million kronor.

#### Broad Cooperative Agreement

In connection with the CGCT tender award, Ericsson also drew up a broad cooperative agreement with Matra which includes cooperation in the mobile telephone area. The agreement covers development, marketing and production of a pan-European digital mobile telephone system which will also be manufactured in France.

"At first CGCT will be a bigger deal, but in the long run the cooperation with Matra will be bigger," said Bjorn Svedberg.

12789

CSO: 5500/2503

## DEREGULATION TO HELP ERICSSON ON FOREIGN MARKETS

Stockholm SVENSKA DAGBLADET in Swedish 2 Apr 87 p 39

[Article by Gote Andersson: "Deregulation Helps Ericsson In The U.S."]

In order to support Ericsson's efforts to market AXE-exchanges in the United States, the Swedish government is going to accelerate deregulation of the Swedish telecommunications market.

A government decision about allowing free competition for business-telephone exchanges is expected already this year.

It presupposes well-informed judges in the National Telecommunications Administration (NTA).

Essentially, the most important part of the NTA's remaining monopoly would thereby disappear.

Claes-Goran Sundelius, counsel for the Ministry of Transport and Communications, does not deny the NTA assertions, but he stresses that as of today there are no decisions in the matter.

#### Reference Group

"A special tele-political reference group within the Communications Ministry is now considering the question," says Sundelius.

He points out that a final decision must be made by the parliament and he says that the earliest time for a government recommendation is most likely going to be the budget proposition in 1988.

It is mainly the Social Democrats who so far have opposed a free market for business-telephone exchanges.

#### Recommendation In June

"The tele-political group can present its recommendation in June, at the earliest," says Gunnel Ferm.

Ferm accounts for a number of reports that argue in favor of the deregulation.

She stresses that the technological development will result in difficulties in maintaining the difference between telecommunications and computer services. That is why the technological development is a reason for deregulation.

#### Reflections

Gunnel Ferm points out that there must be trade-political reflections where deregulation is concerned. Sweden must first look to Europe. She says that if the Swedish market is to be opened to European companies, the European market should be opened to Swedish export.

"A time plan for deregulation must be tied to what happens in Western Europe," says Ferm.

The United States is pressuring for deregulation of the Swedish market. The United States has announced that trade representatives are going to visit Sweden in order to discuss the possibility of American companies entering the Swedish telecommunications market.

Recommendations have been made in the United States about legislation according to a so-called reciprocity principle when it comes to telecommunications products. The feeling is that countries that oppose the import of American telecommunications equipment should also meet with obstacles when its industry wants to export to the United States.

A free market for business-telephone exchanges in Sweden might make it easier for AXE in the United States, according to the Ministry of Transport and Communications.

"The Ericsson company has recommended deregulation of business-telephone exchanges in Sweden, as soon as it is technically feasible," says Hans Werthen, chairman of the board at Ericsson.

#### Consideration

The government must also weigh the advantages of a free market against consideration for the NTA's industrial enterprise, Teli, which today supplies almost all the business-telephone exchanges in Sweden.

Teli's factory in Vanersborg supplies most of the business-telephone exchanges in the country today. Teli has 900 employees in Vanersborg, and the majority of them produce and develop business-telephone equipment.

Gunnel Ferm has received reassuring reports from the NTA, however.

"The NTA has said that Teli will loose in the short run, but gain in the long run with the deregulation," she says.

## Digital Exchanges

Today the business-telephone exchanges constitute the heart of office telephone services. The telecommunications and the computer companies now want to sell new digital exchanges, where the telephone wires can be used for telecommunications as well as for computers.

This means that the technological development is creating a large new market for telecommunications and computer companies, as the need for data-communications increases. Such companies as Siemens, IBM and Philips have made demands for a free market through the Supplier Association for Office and Computer Equipment (LKD),

Despite the fact that NTA loses market shares through deregulation, its director of marketing, Stig Johansson, recommends that it be accomplished.

"If the monopoly is maintained, Swedish trade and economy will not be able to profit by the technological development," he says, and thinks that a decision will be made in the matter within a year.

At the same time, the National Telecommunications Administration is well prepared in case the monopoly is actually removed. During the last couple of years, it has concentrated on increasing the sales of modern business-telephone exchanges. Before 1980, exchanges with about 50,000 extensions were sold annually. Since then the annual sales have increased to about 300,000 extensions. Sweden already has a very large share of large digital business-telephone exchanges today. This means that the NTA will be in a very strong position on the day that competition becomes free.

In all, there are 54,000 business-telephone exchanges with a total of 1.47 million extensions in the country's offices.

12339  
CSO:5500/2492

## ERICSSON, STATE AGENCY IN CONTEST FOR PHONE SWITCH MARKET

Stockholm SVENSKA DAGBLADET in Swedish 14 Apr 87 p 32

[Article by Gote Andersson: "Tug Of War Between EIS And Telecommunications Administration"]

[Text] A tug of war is now beginning between the telecommunications administration and Ericsson Information Systems, Inc. (EIS) for the billion-kronor market which may open up when the telecommunications administration's monopoly on phone switches disappears.

The tug of war is over who will sell a digital phone switch developed jointly by the telecommunications administration and EIS.

Thus far the two had invested approximately 1.5 billion kronor in the switch.

The telecommunications administration will retain the exclusive right to sell the product even when the monopoly is removed, while EIS wants the opportunity to sell it in Sweden.

In Sweden the switch is sold under the name A 335. Abroad it is called MD 110. In this article SVENSKA DAGBLADET will use the name MD 110.

The new switch is EIS's main product on the world market and it is also one of the telecommunications administration's most important products on the Swedish business market.

Up to now the telecommunications administration and EIS have jointly sold such switches for approximately five billion kronor. All told there are approximately one million connections in operation with the switches. Of these, 150,000 are connections in Sweden.

#### Major Export Product

At stake is one of Sweden's major export products. Exports have shot up in recent years.

If the telecommunications administration is really going to lose its monopoly on phone switches, then the relationship between both parties will change too. The government is expected to come up with proposals on the matter later this year.

Negotiations will now begin over future cooperation between EIS and the telecommunications administration, said Stig Larson, managing director of EIS.

He expects the monopoly to be removed beginning 1 January 1989.

#### End Of Monopoly In 1989

"There can be an agreement as to whether we will compete with the telecommunications administration over phone switches on the Swedish market," Stig Larsson told SVENSKA DAGBLADET.

"For EIS, it is a matter of having our own home market where we can sell MD 110," explained Stig Larson. "Today we lack this."

He sees three alternatives for the negotiations. EIS is asking for the right to sell the product in Sweden and thereby compete with the telecommunications administration. Larson predicts the telecommunications administration will retain the exclusive right to supply it in Sweden. The third alternative is for the parties to strike some kind of cooperative agreement.

#### Divvying Up The Market

Stig Johansson, the telecommunications administration's head of marketing, believes that existing agreements between the telecommunications administration and EIS are based on divvying up the market for sales of the switch. He pointed out that if EIS wants to supply MD 110 in Sweden, the telecommunications administration ought to have the opportunity to compete with Ericsson abroad and sell the same switch there.

Jan Silver, who is in charge of marketing phone switches for the telecommunications administration, sees the need for cooperation between the telecommunications administration and EIS. He predicted that a number of other suppliers will get into the Swedish market when the monopoly is removed. This would mean IBM, Siemens and Philips, for example.

"If the telecommunications administration and EIS do not cooperate, there is the risk that foreign suppliers will take a major share of the market," he said.

#### Existing Lines

Both the telecommunications administration and EIS believe firmly in MD 110. Compared with competing systems, today it offers clear benefits, Jan Silver stated. Using this switch, it is possible to use existing telephone wires for data communication as well.

This in turn will make it cheaper for individual firms to provide employees access to data communication than resorting to the building of special data communication networks within a firm. To date that has been the most usual solution in businesses.

Today there are few phone switches capable of doing the same job as MD 110, Silver said.

### 300,000 Connections

EIS has made a mental note of this competitive advantage in a worldwide advertising campaign.

Digital phone switches like MD 110 cost about 5,000 kronor per connection. In recent years, the entire Swedish market has been about 300,000 connections. MD 110 can be sold to the greater part of this market.

Those businesses wishing to have data communication in their phone switches must pay an additional 5,000 to 10,000 kronor per connection for the necessary supplementary equipment. This means that suppliers like EIS and the telecommunications administration will acquire a very big market from those firms that want to use the switch for data communication.

12789

CSO: 5500/2504



## BRIEFS

JOINT DATA COMMUNICATIONS VENTURE--Volvo, SAS and Ericsson are founding a joint firm which will facilitate data communication for Scandinavian businesses. The first service will begin this summer and will enable about 100 large firms to transfer electronic reports. The firm, Scandinavian Info Link, SIL, will then set up a number of services, for example, data base searching, orders for goods and electronic payments. Volvo Data and Ericsson Data Service will own SIL through Verimation, Inc. while SAS will own its part of SIL directly. The managing director of the new firm will be Bjorn Stattin, who is currently the managing director of Verimation, Inc. Business will be conducted out of Stockholm. [Text] [Stockholm SVENSKA DAGBLADET in Swedish 24 Apr 87 p 33] 12789

CSO: 5500/2504

TURKEY

WEST EUROPE

BRIEFS

TV TRANSMITTER--The Sof Dagi transmitter, which will transmit second channel television programs to Gaziantep and part of Kahramanmaras, was inaugurated by State Minister Hasan Ceel Guzel today. The transmitter is broadcasting on UHF channel 27 and is capable of transmitting clearly to an area of 24,000 square km. [Summary] [Ankara Domestic Service in Turkish 1000 GMT 26 May 87 TA] /12913

CSO: 5500/2516

END