

OTS: 60-31,091

JPRS: 3069

17 March 1960

**Reproduced From  
Best Available Copy**

FUNDAMENTAL PROBLEMS IN THE GENERAL THEORY OF CYBERNETIC  
SYSTEMS OF AUTOMATIC CONTROL (USSR)  
(Part III)

Translation

RETURN TO MAIN FILE

Distributed by:

OFFICE OF TECHNICAL SERVICES  
U. S. DEPARTMENT OF COMMERCE  
WASHINGTON 25, D. C.

(Price: \$0.50)

19981208 079

U. S. JOINT PUBLICATIONS RESEARCH SERVICE  
205 EAST 42nd STREET, SUITE 300  
NEW YORK 17, N. Y.

## FOREWORD

This publication was prepared under contract by the UNITED STATES JOINT PUBLICATIONS RESEARCH SERVICE, a federal government organization established to service the translation and research needs of the various government departments.

FUNDAMENTAL PROBLEMS IN THE GENERAL THEORY OF CYBERNETIC  
SYSTEMS OF AUTOMATIC CONTROL (USSR)  
(Part III)

/Translation/

Avtomatika  
/Automation/,  
No 1, January-March 1959, Kiev,  
Pages 39050,  
Ukrainian, per

A. G. Ivaknenko

Introduction

In this part of the work (For parts I and II see Automation, Nos 3 and 4, 1958) we shall reexamine the problem of combined regulation and control by disturbances. As in part II, we shall review the system of simultaneous useful signals and noise. But we shall investigate the methods of improving the interference-proof quality of the system under combined control. The possibility of applying the ordinary theory of combined stabilization systems to cybernetic systems is discussed in part I, and that part therefore represents a further elaboration of these questions. We attach particular importance to the basic structural schemes of both ordinary and cybernetic systems of control.

The possibility of reducing the error of the follow-up system of simultaneous useful signal and interference with the aid of the cybernetic system of its self-changing characteristics.

The experimental methods of proving the existence of extremes and determining the optimum characteristics of compounding are very important, especially in view of the fact that the modern statistical methods have not yet produced any satisfactory conclusions. In particular, as has been shown, these methods cannot be used to include errors originating within the system or the noise-resistance of the system.

Figure 1 shows an experimentally produced dependence of the error of the follow-up system on the noise level  $U_n$ . The scheme of the experimental system and its basic data are indicated in part I. An old phonograph record was used to generate the noise. As may be seen from Figure 1, a simple investigation makes it possible to find, faster and more accurately, the optimum characteristic of compounding (lines  $\phi_2$ ,  $\phi_2^1$ ,  $\phi_2^2$ ,) under which the system's error is at a minimum.

In the case of linear systems (that is small amplitudes), the physical explanation for the nature of the dependence may be found in the statistical theory of linear systems of regulation where the existence of a mean-square error under the effect of interference is mathematically proved. For non-linear systems (that is marking amplitudes) the nature of the dependence (the necessity of raising the amplitude with the increasing interference) can be explained from the point of view of the theory of stabilization of systems with the aid of external influence [1]. It may be seen from the theory that the introduction of sinusoidal external influence, or "white noise," stabilizes the system, that is it reduces the required amplification.

The interference effect on the system's errors may compensate by raising the amplitude as is confirmed by the experiment.

The cybernetic regulator which replaces amplification can act by a) disturbances (interference), b) by the error itself and c) by the combined method of compounding and feedback.

It would seem that the experimental result is of limited significance, since the symbol-changing signal alone is utilized. But that is not so. An investigation shows that in the combined systems (with open and closed parts) the feedback amplifier (or corrector) receives only symbol-changing signals. It follows from this that the results of our investigation can have wide practical application in combined systems.

An analogy between the ordinary systems of automatic control and the method of cybernetic control in the case of simultaneously acting useful signal and noise

An analogy between the ordinary systems of automatic control and the cybernetic system of control, under the simultaneous effect of a useful signal and interference, may be seen from a comparison of Figures 2, 3, 4 and 5.

This analogy also leads to an analogy of the basic premises of the theory of combined systems as applied to ordinary (with permanent characteristics) and cybernetic systems (with self-changing characteristics).

The following basic premises apply to ordinary non-cybernetic systems:

1. In case the interference  $N(t) = N_1(t) + N_2(t)$  can be measured and the amplifier parameters are sufficiently linear, there is no necessity for using the feedback circuit. In this case it is enough to use the open circuit system of noise control Figures 2,a and 3,a).

Taking advantage of the conditions of invariance in a so-called different form, it is possible to select a scheme and compounding connections by interference  $k_n(p)$  or  $l_g(p)$  so as to completely eliminate the effect of the interference  $N(t)$  on the outgoing signal  $\dot{z}(t)$ . With the aid of these connections it is possible to spot the error of any sign or value and eliminate it.

The terms of invariance have been worked out by B. O. Shchipanov, Acad. V. S. Kulebakin, B. M. Petrov, G. V. Ulanov as well as the author [2].

2. In case the interference  $N(t) = N_1(t) + N_2(t)$  cannot be gauged at all and the above-mentioned invariance terms cannot be used, a closed system with a feedback should be utilized (Figure 2,b and 3,b).

The methods of control based on a feedback system are dealt with in all the literature on automatic control problems. We recall that it is precisely in the systems with feedback devices that compromise tuning or the statistical methods of the modern statistical theory are used (as applied to the object, that is to the main system of control).

3. In case the system is under the effect of a number of interferences and only part of them  $N_1(t)$  can be measured while part  $N_2(t)$  cannot be gauged, and in case all the interferences can be measured but the parameters of amplifier  $Y_1(p)$  are insufficiently stable or the characteristics insufficiently linear, use should be made of the combined systems whose schemes are shown in Figure 2,c and 3,c.

The advantages of the combined systems have been mentioned by us before [2].

The scheme and parameters of the feedback circuit on the left part of the dynamics equation are selected by statistical methods or under conditions of compromise tuning. The scheme and parameters of the compounding connections  $l_g(p)$  and  $k_{n1}(p)$  included in the right part of the equation are selected from the terms of the invariance system [in relation to interference  $N_1(t)$ ]. With  $N_1 \neq f(\cdot)$  and the tuning set under conditions of invariance, these two selections are not connected with one another (they are orthogonal).

The objects of cybernetic control shown in Figure 4 and 5 are ordinary control systems with constant characteristics. In this use of cybernetics the ideas of combined control appear to be applied twice: the first time to the object of ordinary control system, and then to the cybernetic system itself. We shall again enumerate the basic premises (in a different application) in the same order as we have done before.

The following major prerequisites apply to cybernetic systems:

1. If the parameters of the spectral compactness of all the interferences  $N(t) = N_1(t) + N_2(t)$  and the useful signal  $y(t)$  can be accurately measured and the characteristics of the 4-polar  $Y_1(p)$ ,  $Y_2(p)$  and  $kn(p)$  are stable, the use of an open-circuit system of extreme cybernetic control is sufficient (Figure 4,a and 5,a).

The cybernetic regulator KP can also affect the scheme, parameters and nonlinearity of the 4-polar device of feedback  $Y_2(p)$  as well as the 4-polar device of the compounding connection  $kn_1(p)$  [ or  $l_s(p)$  ]. An example of systems whereby the  $l_s(p)$  is affected can be found in (2, p. 368). The nonlinear characteristic brought about by regulator KP whereby the root-mean-square error is reduced to a minimum represents the optimum compounding characteristic (part I).

In accordance with the well-elaborated theory of combined systems, a more or less accurate knowledge of nonlinear optimum compounding characteristics is required only in calculating a system that acts by disturbances (Figure 4,a and 5,a). To establish a system with a feedback (4,b and 5,b), all one has to know is that there is a dependence of the regulating influence on interference  $\lambda$  which accounts for the extreme quality  $q$ . The feedback system is a kind of computing attachment which automatically determines the optimum compounding characteristics.

In this way, the mathematical problem of determining the optimum compounding characteristics can be replaced by the problem of proving its existence.

In the case of cybernetic regulators, unlike the ordinary systems, it is frequently necessary to measure not the disturbances and interferences themselves but only certain indicators of their spectral compactness (for example, amplitude  $A$  and frequency  $k$  of the sign-changing signal). This simplifies the compounding operations. For example, it is clear that the change-over to  $k$  frequency can be measured also under conditions of interference.

In other cases the separation of the useful signal from the interference can be achieved by the so-called method of marking impulses. The gist of this method is that the useful signal  $y(t)$  is periodically disconnected for a very short period of time which is used for measuring the interference. The measuring time must be short enough to prevent the follow-up system from reacting to the disconnected signal. In other cases provisions should be made for disconnecting the servomotor during the interference measurements.

Under a different variation of that method, the  $\psi(t)$  programs is not disconnected but takes on permanent and previously known values for a short time.

To some extent this applies also to the stabilization system where it is not necessary to separate interference  $N_1(t)$  from the load of object  $L(t)$  as it is possible to eliminate their influence at the same time.

In a number of cases (with a pronounced spectral compactness of the signal and interference), the compounding can be carried out by the two frequency-filter method developed by Burt [3].

The following may be the controlling influences in the cybernetic adaptation to the conditions of work: a) the change in the parameter values of the main system, b) the change of its scheme (that change is an additional influence which tends to broaden the range of parameter changes), and, finally, c) the change of the nonlinear characteristics of the amplifier or feedback from the "southern" characteristics (form S) to the "northern" characteristics (form N) and vice versa.

Lack of space prevents us from examining the very interesting problem of a smooth change in the structure of the control system with the aid of R, L and C grids (the same as in integrators) and other equipment. This idea requires further elaboration.

2. In case the parameters of the spectral compactness of the signal and all interferences  $N(t) = N_1(t) + N_2(t)$  cannot be measured, the closed-circuit system of extreme control from the feedback with ELD (Figure 4,b and 5,b) is used.

Present in most cases are oscillations (poshukovi) [?] in the feedback circuit although there are known cases of non-oscillating feedbacks. For example, the feedback of the extreme (ekstremal'nyy) regulator can be non-oscillating if the conditions corresponding to the extreme characteristic points of the object are at the same time present in certain other cases [4].

It is frequently more important to measure the quality index of  $\epsilon$  than to measure the basic parameters of the interferences. The above-described method, known as the "marking impulses method," can sometimes be used for measuring the mean effective value of an error. The gist of this method is that certain influences of known values are periodically introduced into the system. The duration of the marking impulses should be longer than the duration of the transitional processes in the system. We are then able to make accurate measurements of the system's errors, brought about by the presence of noise  $\epsilon = \psi(t) - \psi'(t)$  at the end of every marking impulse.

This measurement enables us to put into effect any known scheme of selfchanging frequency characteristics of the main system; automatic oscillation: a) by derivatives  $\dot{A}$  and  $\dot{B}$ , b) by maximum memorization and forced oscillations c) step-by-step method, d) modulating influence [2].

In the selection of the scheme and characteristics of a regulator feedback it is possible to apply once more the idea of compromise tuning and possibly also the statistical methods. These ideas have so far been used only for synthesizing the feedbacks of the principal ordinary system. At a certain stage of development of the extreme systems the same methods could be used also for a synthesis of feedbacks with ELD as is being used in extreme cybernetic controls. So far there has been no published material available in this field. It is not difficult to visualize the possibility of a third, fourth and future applications of the principle of self-changing characteristics. Thus it is easy to imagine the expediency of self-changing characteristics of a cybernetic regulator designed for use in connection with the self-changing characteristics of the main system, in case this regulator is not ideal for the purpose, possesses momentum, etc. Such multiple systems of self-changing characteristics have not yet been created but adequate machinery for that is available in the field of mathematics, and that is the method of successive approximations (iterations) to the most ideal solution, and the known methods of evaluating the limitations of the first, second and further approximations. The ordinary system with constant characteristics selected during the tuning corresponds to the first approximation; the additional cybernetic regulators KR (Figure 4 and 5) correspond to the second; the additional regulators for the cybernetic controls to the third, etc.

3. If the parameters of the spectral compactness of the signal and part of the  $N_1(t)$  interference can be measured while the  $N_2(t)$  interference cannot, and if the parameters of the spectral compactness of all the interferences can be measured but the characteristics of the 4-polar  $Y_1(p)$ ,  $Y_2(p)$ ,  $kn_1(p)$  and  $l_g(p)$  are insufficiently stable, the combined cybernetic system (Figure 4,c and 5,c) should be used.

The advantage of the combined systems is that they increase the accuracy and speed of the system's operation while reducing the power and range of operation of the feedback with an ELD.

An example of determining the optimum characteristics of compounding by the statistical approximation method

Even the linear compounding connections can well improve the accuracy and speed of the system's operation and its noise-resistance. But the greatest effect can be achieved by the use of nonlinear compounding



connections with specially selected nonlinear characteristics which corresponds to the optimum characteristic of compounding (see Part I).

Approximate analytical methods make possible a simple solution to the problem of selecting interference and controlling influence as well as the calculation of the optimum nonlinearity of each of them.

As an example of the application of the approximate statistical method to the cybernetic system we shall examine the selection of an amplification coefficient of the follow-up system depending on the relationship between the spectral aspect of the useful signal  $\psi(t)$  and interference  $N(t)$ . In this case a change of the different parameters is necessary to compensate for the influence of the changing specters on the signal and the interference on the system. The follow-up system shown in Figure 6 is a system designed to look for the brightest part of the horizon. Such a system can be applied both in astronomy, for tracking a luminous celestial body, and a cybernetic "tortoise-shell." Angle  $\psi$  plotted on the luminous body and the North-South line (the body azimuth) may be assumed to be the signal governing the system.

Angle  $\Phi$  is the initial value between the longitudinal axis of the "tortoise-shell" and the North-South line (the "tortoise-shell" azimuth). Owing to the presence of other luminous bodies which revolve around the "tortoise-shell," the changing transparency of the surrounding atmosphere and other causes, signal  $S(t)$  may be represented as the sum of the useful signal  $\psi(t)$  and interference (noise)  $N(t)$ , both of them being stationary accidental functions of the time:

$$S(t) = \psi(t) + N(t) .$$

We shall make a brief analysis of the system under investigation.

The equation of the dynamics of the system's elements looks like the following:

$$\text{The law of control } \Sigma = \psi - \Phi - m_1 \rho \dot{\Phi} ;$$

$$\text{amplifier } \mu = \alpha_1 \Sigma ;$$

$$\text{servomotor } (\tau \rho + 1) \rho \dot{\Phi} = \alpha_2 \mu ,$$

where  $\mu$  stands for tension at the amplifier outlet;  $\tau$  for the constant of servomotor time;  $m_1$  for the coefficient of tacho-generator  $\rho$ .

Eliminating the interim changes of  $\Sigma$  and  $\mu$ , we find the following equation of the dynamics of the entire system in a closed-circuit position:

$$\left[ \tau p^2 + (1 + \alpha_1 \alpha_2 m_1) p + \alpha_1 \alpha_2 \right] \Phi = \alpha_1 \alpha_2 \Psi \text{ or}$$

$$\Phi = Y_3(p) \Psi.$$

Full conductivity of the system in a closed position:

$$Y_3(p) = \frac{\omega_0^2}{p^2 + \frac{1 + \alpha_1 \alpha_2 m_1}{\tau} p + \omega_0^2} \text{ where } \omega_0^2 = \frac{\alpha_1 \alpha_2}{\tau} = \frac{\alpha \rho}{\tau}$$

The relative fading factor of the system is:

$$c_{12} = \frac{1 + \alpha_1 \alpha_2 m_1}{2 \omega_0} \text{ , where } \omega_0 = \sqrt{\frac{\alpha \rho}{\tau}}.$$

By replacing  $p - j\omega$  it is possible to construct a number of amplitude-phase characteristics of the system in a closed position with an unlimited reading of frequency  $\left(\frac{\omega}{\omega_0}\right)$  under different values of the fading factor  $c_{12}$  (Figure 7,2). The intersection points of these characteristics with a single radius determine the frequency value of section  $\omega_{j\rho}$ . Making use of the diagram in Figure 7,a, we find an auxiliary diagram (Figure 7,b) where the dependence  $\frac{\omega_{j\rho}}{\omega_0} = f(c_{12})$  has been proved.

If we assume that the amplifier is characterized as a rectangle:

$$\begin{array}{ll} \text{with } 0 < \omega < \omega_{j\rho} & M = \text{const. and} \\ \text{with } 0 > & M = 0 \end{array}$$

then, as G. Dutil showed (5, p. 160), the optimum relationship between the noise spectrum, useful signal and filtering zones which produce a minimum root-mean-square error are determined by the following simple expression:

$$S_{\Psi}(\omega_{j\rho}) = S_N(\omega_{j\rho}).$$

The disturbing influences are the parameters of the spectrum of the useful signal and interference frequencies. A further interpretation calls for the knowledge of the spectral characteristics (compactness) of the  $\psi(t)$  signal and the spectral characteristics of noise. Supposing that the luminous body under observation by the follow-up system is moving along the horizon in jerks, under the law of rectangular sign-changing impulses. In case the probability of frequency change comes under the Poisson exponential law, the spectral compactness (5) is expressed as

$$S_{\Psi}(\omega) = \frac{A^2}{\pi} \cdot \frac{2k}{(2h)^2 + \omega_{j\rho}^2},$$

where  $k$  represents the average number of intersections by the  $\psi(t)$  function of the time axis per second (current frequency). Let us assume that the noise which makes the search difficult is a so-called "white noise" whose energy is the same in all frequencies  $S_N(\omega) = a^2$ .

Such spectral characteristics of the signal and noise may be obtained analytically by way of arranging the related functions in Fourier series, or experimentally with the aid of harmonic analyzers or correlators.

Under the G. Dutil method, the optimum relationship between the parameters of the system and those of the spectral compactness of the signal and noise corresponds to the following relation:

$$S_{\psi}(\omega_{3P}) = S_N(\omega_{3P}),$$

where  $\omega_{3P}$  stands for the "cutoff frequency" of the system.

This correlation can be used for calculation purposes through the medium of the following two correlations:

$$1) \frac{3P}{\omega_0} = f(c_{12}) \quad (\text{Portrayed graphically in Figure 7,b),}$$

and

$$2) \frac{A^2}{\pi} \cdot \frac{2k}{(2k)^2 + \omega_{3P}^2} = a^2.$$

These equations can both be solved by plotting them on a chart. The various point, for example, can be used for plotting a number of curves (Figure 7,b).

$$1) \omega_0 = f_2(\omega_{3P}) \quad \text{with } c_{12} = \text{const.}$$

$$2) k = f_3(\omega_{3P}) \quad \text{with } \frac{A}{a} = \text{const.}$$

The range of the change of the  $c_{12}$  and  $\frac{A}{a}$  values in the actual systems is known beforehand.

The intersection points of the curves show the optimum relationship between the systems  $\omega_0$ ,  $\omega_{12}$ ,  $\omega_{3p}$  and the parameters of the spectra  $\frac{A}{a}$

and  $k$ . With the use of this diagram it is easy, for example, to find out how  $\omega_{12}$  and  $\omega_{3p}$  should change (and that applies also to the  $\omega_p$ ,  $\omega_m$ , magnitudes) under conditions of a slow  $\frac{A}{a}$  and  $k$  change,

that is to find the diagram corresponding to the optimum compounding characteristics. The corresponding compounding connection of  $\frac{A}{a}$  and

$k$  should produce such characteristics in order to achieve a minimum root-mean-square error.

The graphic methods of determining the optimum compounding characteristics can be applied not only to a different type system (which is reviewed in this example) but they can also be developed to apply to more complicated systems. The nonlinear dependence

$$f\left(\frac{A}{a}, k, \omega_{12}, \omega_0\right) = 0,$$

shown in Figure 7,b, is brought about with the aid of compounding by noise. We assume that in case of a feedback it is not necessary to know about this dependence -- it is enough to prove that it exists.

Figures 8 and 9 show examples of cybernetic systems with a self-changing amplification factor of the main follow-up system acting a) by disturbance and b) by an indicator of the system's errors with the aid of a feedback. The error of the system is measured periodically by the marking impulse method (Figure 10). The combination of Figures 8 and 9 gives an idea of the combined system of the self-changing amplification factor.

There is one more advantage of the combined system, in addition to the above-mentioned: the system can be controlled (though more crudely) during the periodic change of  $\omega_0$  and in the intervals between them. The self-changing amplification factor  $\omega_{3p}$  does not cease to function, and that also increases the accuracy and efficiency of the system.

Reducing the influence of interference with  
the aid of differential schemes and models  
of the object of regulation.

We have reviewed the methods of reducing the effect of interference by way of reducing the act of compounding connections (invariance conditions) and the effect of the feedback circuit (the introduction of another derivative nonlinear intensity, selecting the time for switching on the servomotor and the amplitude of the controlling influence,

selecting a method of measuring and integrating the extreme indicator, the use of correlators, etc.

The method of reducing the interference influence by the use of differential schemes is of intermediate value. That method, just like the use of feedbacks, eliminates all extraneous interference, not only the major disturbances; on the other hand, the differential scheme eliminates errors only when the unbalance is small, near zero characteristics.

The examples of electronic amplifier-analogues, cited in 4, show that the differential schemes will indeed occupy an intermediate position in the concept of interference elimination.

In the differential scheme the compounding contact acting by disturbance is replaced by another system of (extreme) control or a model of it. It is necessary that both systems be as similar as possible and under almost the same working conditions and come under the same outside influence.

The performance cycle of the (step-by-step) regulator is selected in such a way that the controlling influence (in example 4 the introduction of air) is simultaneously increased in one object and decreased in another by the same magnitude. By comparing the values of the extreme (temperature) indicator of both objects, it is easy to ascertain by the difference between them whether the constant component of the controlling influence should be increased or reduced in order to produce an extreme. As has already been pointed out, the effects of small interferences in such a differential system are mutually exclusive.

Making good use of the developed theory of derivative process in differential amplifiers, it is possible to show that not only the static error  $\Delta_1$  but also dynamic error  $\Delta_2$  is reduced almost to zero, in comparison with the unit system, which results in a considerable efficiency increase. The time between the changes from one extreme to the other is sharply reduced.

One of the schemes comprising the common differential scheme can be replaced by a model or a computing device. Such a model, however, should accurately reflect all the attributes of the actual object of regulation.

#### BIBLIOGRAPHY

1. Ol'denburger, "The Stabilization of Control Systems With the Aid of a Special Signal," Avtomatika i Telemekhanika [Automation and Telemechanics], No 5, 1957.
2. A. G. Ivakhnenko, Elektroavtomatika [Power Automation], State Publishing house of technical literature of the Ukrainian SSR, first edition, 1953; second edition, 1956.
3. E. G. Burt, "Self-Optimizing Systems," Betrag, No 86, Fachtgung Regeltechnik, Heidelberg, 1956.
4. O. [sic] G. Ivakhnenko, A series of articles on technical cybernetics, Avtomatika No 1, 2, 3 and 4, 1958.
5. Avtomaticheskoe Regulirovanie [Automatic control], a collection of materials from the conference at Crenfield, 1951, p 160.
6. Ekspress-informatsiya [Express-Information], AU series, 36 edition, 1957, No 146-149.

Submitted for publication on 3 March 1958.

FIGURE APPENDIX

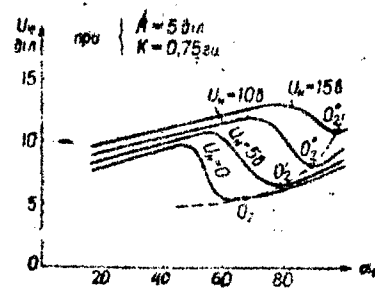

Figure 1. The dependence of the error of the follow-up system on the interference (noise) level and amplification factor  $\alpha_p$ . The interference consists of "white noise." The useful signal is of a rectangular, sign-changing type.

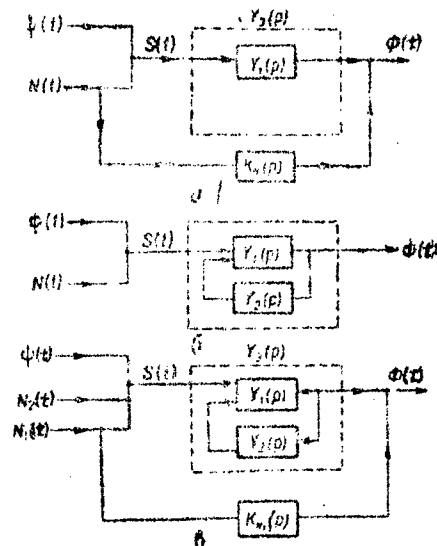
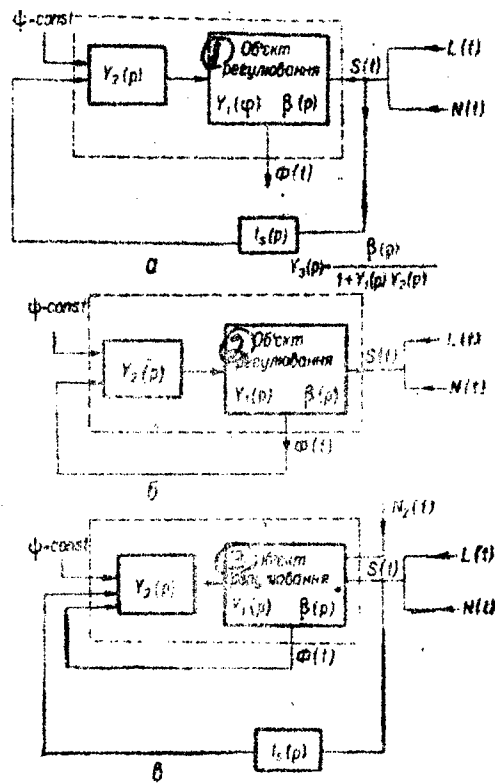

Figure 2. The basic methods of improving the accuracy of the ordinary follow-up systems under the effect of interference.

a) an open circuit follow-up system with the complete elimination of errors brought about by interference  $N(t)$  with the aid of the compounding connection  $K_n(p)$ ; b) a follow-up system with a feedback in which the error brought about by interference  $N(t)$  can be reduced to a minimum by selecting  $Y_2(p)$ ; c) a combined system whereby the error caused by interference  $N_1(t)$  is completely eliminated, and the error occasioned by  $N_2(t)$  is reduced to a minimum.



1. object of regulation, 2. object of regulation
3. object of regulation

Figure 3. The principal methods of improving the accuracy of ordinary stabilization system under the effect of interferences:

- a) open-circuit stabilization system in which the error occasioned by  $S(t)$  can be completely eliminated with the aid of compounding connection  $l_g(p)$ ;
- b) a stabilization system with a feedback whereby the error brought about by  $S(t)$  can be reduced to a minimum by selecting  $Y_3(p)$ ;
- c) a combined stabilization system whereby the error produced by the  $S(t)$  load is completely eliminated and the error produced by  $N_2(t)$  is reduced to a minimum.



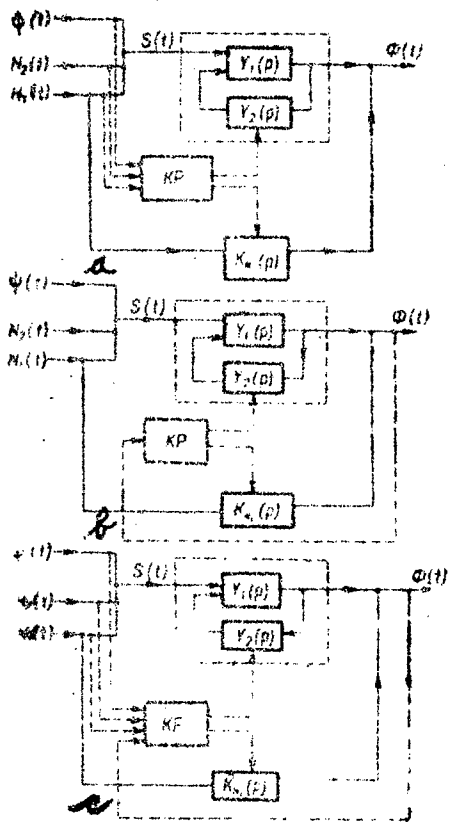
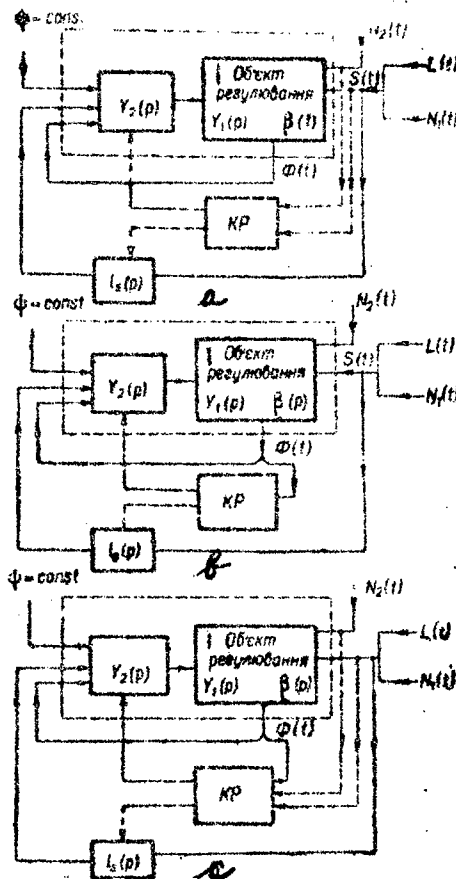

Figure 4. A cybernetic follow-up system with self-changing  $Y_2(p)$  and  $k_\lambda(p)$ :

- a) by interference, b) by the feedback principle with ELD, c) by a combination of them.



1. object of regulation

Figure 5. A cybernetic follow-up system with self-changing  $Y_2(p)$  and  $l_s(p)$ :

- a) by interference, b) by the feedback principle with ELD, c) by a combination of them.

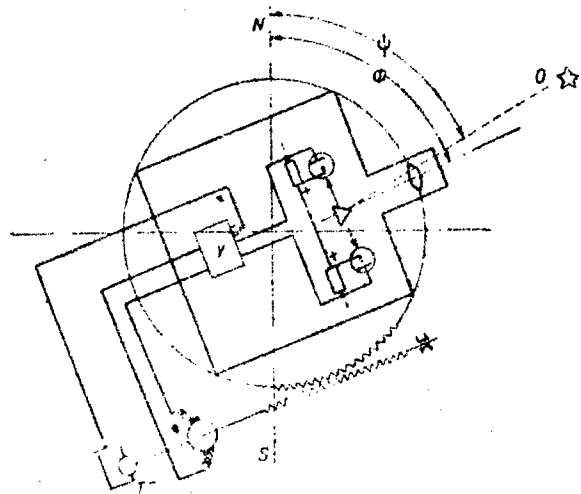

Figure 6. Diagram of the system tracking a body in a certain section of the horizon.

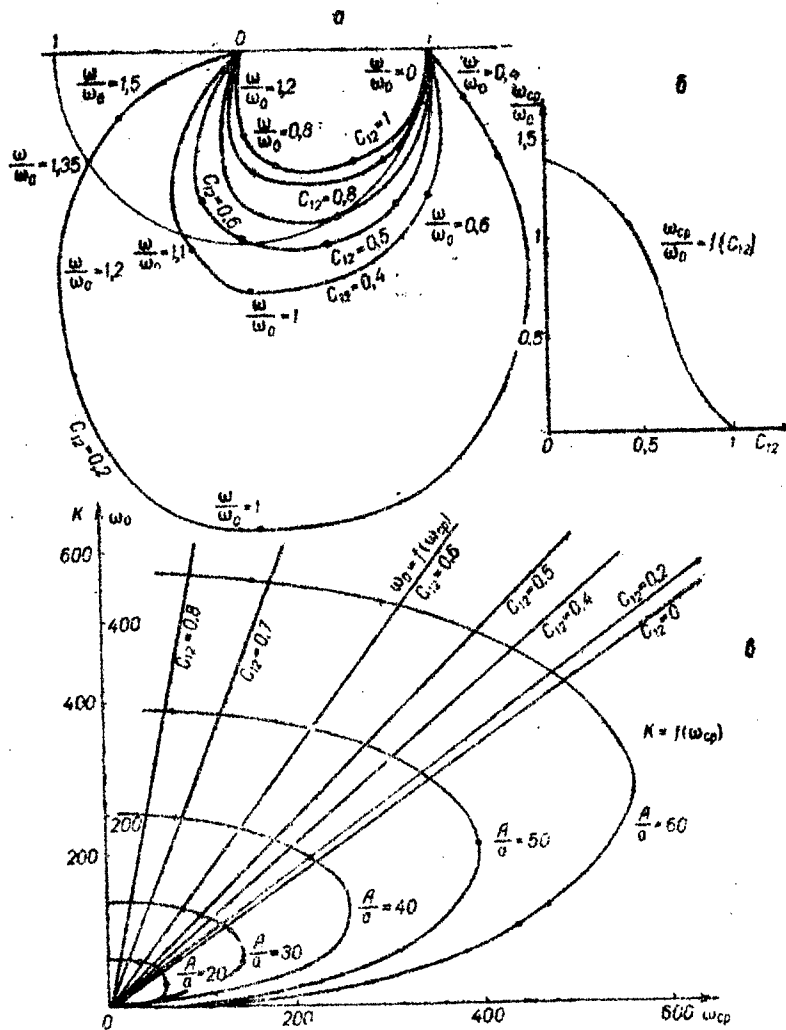

Figure 7. Graphic method of determining the optimum characteristics of compounding:

- a) amplitude-phase characteristics of the system in under changing values of the fading coefficient  $c_{12}$ ;
- b) the  $\frac{\omega_{cp}}{\omega_0} = f(c_{12})$  dependence;
- c) graphic method of determining the optimum characteristics of compounding.

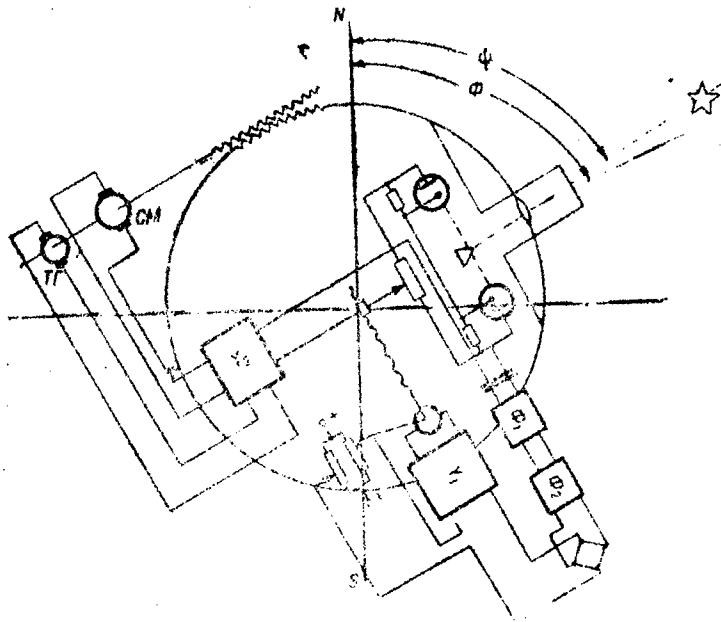

Figure 8. Diagram of the system tracking the position of a luminous body whose self-changing amplification factor depends on the interference intensity (the principle of disturbances).

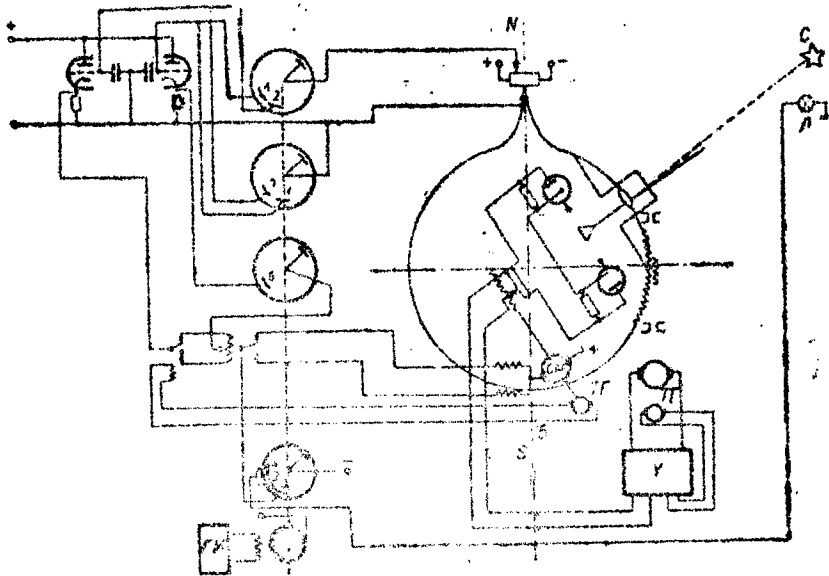

Figure 9. Diagram of the system tracking the position of a luminous body whose self-changing amplification factor depends on the interference intensity (by the principle of the noise magnitude indicator).

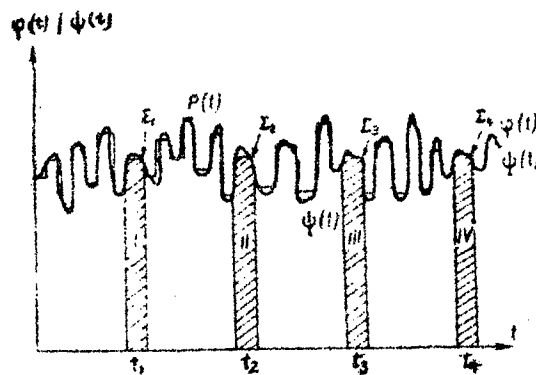

Figure 10. The introduction of marking impulses (I, II, III, IV) for the periodic measurement of the system's errors ( $\epsilon_1, \epsilon_2, \epsilon_3, \epsilon_4$ ).