

111146

JPRS-UEE-84-003

21 March 1984

USSR Report

ELECTRONICS AND ELECTRICAL ENGINEERING

DISTRIBUTION STATEMENT A
Approved for public release
Distribution Unlimited

FBIS

FOREIGN BROADCAST INFORMATION SERVICE

Reproduced From
Best Available Copy

6
83
A05

NOTE

JPRS publications contain information primarily from foreign newspapers, periodicals and books, but also from news agency transmissions and broadcasts. Materials from foreign-language sources are translated; those from English-language sources are transcribed or reprinted, with the original phrasing and other characteristics retained.

Headlines, editorial reports, and material enclosed in brackets [] are supplied by JPRS. Processing indicators such as [Text] or [Excerpt] in the first line of each item, or following the last line of a brief, indicate how the original information was processed. Where no processing indicator is given, the information was summarized or extracted.

Unfamiliar names rendered phonetically or transliterated are enclosed in parentheses. Words or names preceded by a question mark and enclosed in parentheses were not clear in the original but have been supplied as appropriate in context. Other unattributed parenthetical notes within the body of an item originate with the source. Times within items are as given by source.

The contents of this publication in no way represent the policies, views or attitudes of the U.S. Government.

PROCUREMENT OF PUBLICATIONS

JPRS publications may be ordered from the National Technical Information Service (NTIS), Springfield, Virginia 22161. In ordering, it is recommended that the JPRS number, title, date and author, if applicable, of publication be cited.

Current JPRS publications are announced in Government Reports Announcements issued semimonthly by the NTIS, and are listed in the Monthly Catalog of U.S. Government Publications issued by the Superintendent of Documents, U.S. Government Printing Office, Washington, D.C. 20402.

Correspondence pertaining to matters other than procurement may be addressed to Joint Publications Research Service, 1000 North Glebe Road, Arlington, Virginia 22201.

Soviet books and journal articles displaying a copyright notice are reproduced and sold by NTIS with permission of the copyright agency of the Soviet Union. Permission for further reproduction must be obtained from copyright owner.

JPRS-UEE-84-003

21 MARCH 1984

19981105 025

USSR REPORT
ELECTRONICS AND ELECTRICAL ENGINEERING

DTIC QUALITY INSPECTED 3

FOREIGN BROADCAST INFORMATION SERVICE

REPRODUCED BY
**NATIONAL TECHNICAL
INFORMATION SERVICE**
U.S. DEPARTMENT OF COMMERCE
SPRINGFIELD, VA. 22161

NOTE

JPRS publications contain information primarily from foreign newspapers, periodicals and books, but also from news agency transmissions and broadcasts. Materials from foreign-language sources are translated; those from English-language sources are transcribed or reprinted, with the original phrasing and other characteristics retained.

Headlines, editorial reports, and material enclosed in brackets [] are supplied by JPRS. Processing indicators such as [Text] or [Excerpt] in the first line of each item, or following the last line of a brief, indicate how the original information was processed. Where no processing indicator is given, the information was summarized or extracted.

Unfamiliar names rendered phonetically or transliterated are enclosed in parentheses. Words or names preceded by a question mark and enclosed in parentheses were not clear in the original but have been supplied as appropriate in context. Other unattributed parenthetical notes within the body of an item originate with the source. Times within items are as given by source.

The contents of this publication in no way represent the policies, views or attitudes of the U.S. Government.

PROCUREMENT OF PUBLICATIONS

JPRS publications may be ordered from the National Technical Information Service (NTIS), Springfield, Virginia 22161. In ordering, it is recommended that the JPRS number, title, date and author, if applicable, of publication be cited.

Current JPRS publications are announced in Government Reports Announcements issued semimonthly by the NTIS, and are listed in the Monthly Catalog of U.S. Government Publications issued by the Superintendent of Documents, U.S. Government Printing Office, Washington, D.C. 20402.

Correspondence pertaining to matters other than procurement may be addressed to Joint Publications Research Service, 1000 North Glebe Road, Arlington, Virginia 22201.

Soviet books and journal articles displaying a copyright notice are reproduced and sold by NTIS with permission of the copyright agency of the Soviet Union. Permission for further reproduction must be obtained from copyright owner.

21 March 1984

USSR REPORT

ELECTRONICS AND ELECTRICAL ENGINEERING

CONTENTS

AEROSPACE AND ELECTRONIC SYSTEMS

- On the Principle of Uniformity of Satellite Communications Systems
(L. Ya. Kantor; ELEKTROSVYAZ', No 10, Oct 83)..... 1
- International Prototype Network in 'Dubna' Experimental Satellite Communications System
(V. L. Bykov, Ye. Aleksandrova, et al.; ELEKTROSVYAZ', No 10, Oct 83)..... 2
- Basic Properties and Interpretation of Synthesized Radar Images of Sea Waves With Long Synthesization Time
(A. V. Ivanov; IZVESTIYA VYSSHIKH UCHEBNIKH ZAVEDENIY; RADIOFIZIKA, No 5, May 83)..... 3

ANTENNAS AND PROPAGATION

- Multitrunk High-Frequency Multiplexing of Antenna-Waveguide Channels
(A. M. Model', V. A. Stuzhin, et al.; ELEKTROSVYAZ', No 9, Sep 83)..... 4
- Method of Constructing Folding Umbrella-Type Antenna
(V. I. Loman, M. V. Gryanik; IZVESTIYA VYSSHIKH UCHEBNIKH ZAVEDENIY; RADIOELEKTRONIKA, No 8, Aug 83).... 5
- Frequency Independent Parabolic Phased Antenna Array of Log Periodic Antenna
(B. A. Veriga, N. I. Vyakhirev; IZVESTIYA VYSSHIKH UCHEBNIKH ZAVEDENIY; RADIOELEKTRONIKA, No 8, Aug 83).... 6
- Minimizing Field Scattered by Slender Dipoles
(L. I. Ponomarev, A. V. Dolgiy; IZVESTIYA VYSSHIKH UCHEBNIKH ZAVEDENIY; RADIOELEKTRONIKA, No 8, Aug 83).... 7

BROADCASTING/CONSUMER ELECTRONICS

Modernization of Third Generation TV Equipment (V. M. Palitskiy; TEKHNIKA KINO I TELEVIDENIYA, No 9, Sep 83).....	8
Prospects for Using Microprocessors in Professional Video Tape Recorders (N. N. Lapshov; TEKHNIKA KINO I TELEVIDENIYA, No 9, Sep 83).....	9
Mobile Video Tape Recorder Editing Room (O. P. Baranov, V. I. Nelipa, et al.; TEKHNIKA KINO I TELEVIDENIYA, No 9, Sep 83).....	9
Transmitter Spectrum Analyzer (B. Stepanov, G. Shul'gin; RADIO, No 9, Sep 83).....	10
Module for Interfacing Microprocessors and Microcomputer (G. Zelenko, V. Panov, et al.; RADIO, No 9, Sep 83).....	10
Feasibility of Using Passive Television Relaying Devices (V. D. Kuznetsov; ELEKTROSVYAZ', No 9, Sep 83).....	11
Predicting Electrical Performance Parameters of Underwater Cables (G. A. Arkhangel'skiy; ELEKTROSVYAZ', No 9, Sep 83).....	12
Special Features of Transmitter Tuning (V. K. Yemel'yanov; VESTNIK SVYAZI, No 10, Oct 83).....	12
Device for Combining Signals From Television Transmitters Into Common Antenna Feeder System (V. L. Bobylin; VESTNIK SVYAZI, No 10, Oct 83).....	13
Some Developmental Trends in Television Broadcasting Systems (A. M. Varbanskiy; ELEKTROSVYAZ', No 10, Oct 83).....	14
RSFSR Conference on Improving Quality and Reliability of Low-Power Television Repeater Operation. Result of All- Russian Conference (N. I. Gormakova, A. I. Yushkin; ELEKTROSVYAZ', No 10, Oct 83).....	14

CIRCUITS AND SYSTEMS

Design of Digital Bandpass Filters With Finite Memory (V. V. Vityazev, S. I. Murav'yev, et al.; IZVESTIYA VYSSHIKH UCHEBNYKH ZAVEDENIY: RADIOELEKTRONIKA, No 9, 1983).....	16
---	----

Maximally Flat Approximation of Attenuation Characteristics of Coupled-Line Filters (I. I. Trifonov, V. N. Salivon; IZVESTIYA VYSSHIKH UCHEBNIKH ZAVEDENIY: RADIOELEKTRONIKA, No 8, Aug 83)....	25
Miniature Two-Mode Filters (M. N. Berger, B. Yu. Kapilevich, et al.; ELEKTROSVYAZ', No 9, Sep 83).....	25
Method of Designing Digital Band-Pass Filters With Pulse Response of Finite Duration (V. V. Vityazev, S. I. Murav'yev, et al.; IZVESTIYA VYSSHIKH UCHEBNIKH ZAVEDENIY: RADIOELEKTRONIKA, No 9, Sep 83),.....	26

COMMUNICATIONS

Generalization of Discrete Fourier Transform for Interpolation in Time Domain (V. A. Ponomarev, O. V. Ponomareva; IZVESTIYA VYSSHIKH UCHEBNIKH ZAVEDENIY: RADIOELEKTRONIKA, No 9, 1983).....	27
Optimum Predistortion of Digital Signals for Transmission Over Parallel Channels (L. M. Krasnov, V. K. Marigodov; IZVESTIYA VYSSHIKH UCHEBNIKH ZAVEDENIY: RADIOELEKTRONIKA, No 9, Sep 83)....	31
Estimate of Signal-to-Interference Energy Ratio in Discrete- Data Transmission (Yu. V. Arzumanyan, A. A. Zakharov; IZVESTIYA VYSSHIKH UCHEBNIKH ZAVEDENIY: RADIOELEKTRONIKA, No 9, Sep 83)....	32
Efficiency of Discrimination in Some Invariant Signal Transformations (B. A. Atayants, V. P. Rumyantsev; IZVESTIYA VYSSHIKH UCHEBNIKH ZAVEDENIY: RADIOELEKTRONIKA, No 9, Sep 83)....	32
Generalization of Discrete Fourier Transformation for Interpolation in Time Domain (V. A. Ponomarev, O. V. Ponomareva; IZVESTIYA VYSSHIKH UCHEBNIKH ZAVEDENIY: RADIOELEKTRONIKA, No 9, Sep 83)....	33
Optimality Criterion for High-Frequency Channel in Receivers of Discrete Radio Signals (V. V. Palshkov; IZVESTIYA VYSSHIKH UCHEBNIKH ZAVEDENIY: RADIOELEKTRONIKA, No 9, Sep 83).....	34
Controllable Companding in Low-Frequency F-M Radio Communication Systems (E. S. Golovin; IZVESTIYA VYSSHIKH UCHEBNIKH ZAVEDENIY: RADIOELEKTRONIKA, No 9, Sep 83).....	34

Gradiantial Adaptive Corrector With Optimum Tuning Step (V. S. Mikhal'chan; IZVESTIYA VYSSHIKH UCHEBNIKH ZAVEDENIY: RADIOELEKTRONIKA, No 9, Sep 83).....	35
Nonlinear Filtration of Clutter (Zh. A. Sabirov; IZVESTIYA VYSSHIKH UCHEBNIKH ZAVEDENIY: RADIOELEKTRONIKA, No 9, Sep 83).....	36
Synthesis of System With Nonideal Components for Optimal Processing of Radio Signal (V. G. Tatarnikov; IZVESTIYA VYSSHIKH UCHEBNIKH ZAVEDENIY: RADIOELEKTRONIKA, No 9, Sep 83).....	36
Automation of Design of Large Telephone Networks (Review) (O. F. Sergeyeva; ELEKTROSVYAZ', No 9, Sep 83).....	37
Dialing Systems in International Telephone Network (Review) (M. A. Zharkov; ELEKTROSVYAZ', No 9, Sep 83).....	38
Estimating Optimum Technical and Economic Indicators of Data Transmission Systems (L. A. Shareyko; ELEKTROSVYAZ', No 9, Sep 83).....	38
Use of Digital Equipment in USSR Unified Automated Communications Network (E. V. Kordonskiy, Ye. S. Mamonov, et al.; ELEKTROSVYAZ', No 10, Oct 83).....	39
Reconstitution of Diverse Sheaths for Telephone Cables Without Intermediate Wrapper (A. K. Belenko; VESTNIK SVYAZI, No 10, Oct 83).....	40
Developmental Trends in Radio Receiver Design (N. I. Chistyakov; ELEKTROSVYAZ', No 10, Oct 83).....	41
Reconstruction of Existing Communications Trunk Lines; Introduction (ELEKTROSVYAZ', No 10, Oct 83).....	41
General Principles of Cable Transmission Line Reconstruction (L. T. Kim; ELEKTROSVYAZ', No 10, Oct 83).....	42
Communications Trunk Retrofit Variants Replacing K-1920 Transmission Systems by K-3600 (A. V. Lebedev, L. T. Kim; ELEKTROSVYAZ', No 10, Oct 83).	43
Initial Experience With Replacement of Transmission System on Coaxial Cable (R. V. Chervinskiy, A. M. Press; ELEKTROSVYAZ', No 10, Oct 83).....	43

Lessons in Communications Cable Line Reconstruction (M. N. Khutoryanskiy; ELEKTROSVYAZ', No 10, Oct 83).....	44
Work To Enhance Reliability and Increase Capacity of Primary Network (V. A. Meng; ELEKTROSVYAZ', No 10, Oct 83).....	45

COMPUTERS

Synthesis of Tests for Programmable Logic Arrays (A. Ye. Lyul'kin, T. G. Pavlova; MIKROELEKTRONIKA, No 4, Jul-Aug 83).....	46
Detection of and Search for Faults in Programmable Logic Arrays (M. B. Volynskiy, V. G. Novoselov; MIKROELEKTRONIKA, No 4, Jul-Aug 83).....	47
Filtration of Higher Harmonic Components in Two-Level Digital Computing Synthesizers (A. N. Fadeyev; IZVESTIYA VYSSHIKH UCHEBNYKH ZAVEDENIY: RADIOELEKTRONIKA, No 9, Sep 83).....	47
Art of Programming Programmable Microcalculators, Part 4: Errors of Calculations (Ya. K. Trokhimenko, F. D. Lyubich; IZVESTIYA VYSSHIKH UCHEBNYKH ZAVEDENIY: RADIOELEKTRONIKA, No 9, Sep 83)....	48

ELECTRICAL INSULATION

Examination of Anisotropic Films by Resonance Method (A. A. Vertiy, I. V. Ivanchenko, et al.; IZVESTIYA VYSHHIKH UCHEBNYKH ZAVEDENIY: RADIOFIZIKA, No 5, May 83).....	49
--	----

ELECTRON DEVICES

Estimating Angular Position of Optical Radiation Source When Received by Array of Photodetectors (L. D. Vilesov, V. N. Veys; IZVESTIYA VYSSHIKH UCHEBNYKH ZAVEDENIY: RADIOELEKTRONIKA, No 8, Aug 83)....	50
KT3127A, KT3128A Transistors (N. Ovsyannikov; RADIO, No 11, Nov 83).....	51
TEMO and TEB Thermoelectronic Devices (P. Gassanov, G. Voytenko, et al.; RADIO, No 11, Nov 83).	51

INSTRUMENTATION AND MEASUREMENTS

Digital Tachometer (B. Shirokov; RADIO, No 9, Sep 83).....	52
General Design Principles of High Speed Frequency Synthesizers Based on Phase Synchronization Systems (V. V. Shakhgil'dyan, A. V. Pestryakov, et al.; ELEKTROSVYAZ', No 10, Oct 83).....	52
Sound Signal Quasi-Peak Level Meters (A. A. Miller, A. P. Prigozhin, et al.; TEKHNIKA KINO I TELEVIDENIYA, No 9, Sep 83).....	53

MICROWAVE THEORY AND TECHNIQUES

Strongly Coupled Millimeter-Band Waveguide Directional Couplers (A. N. Akhiyezer; IZVESTIYA VYSSHIKH UCHEBNYKH ZAVEDENIY: RADIOELEKTRONIKA, No 8, Aug 83).....	54
Application of Field Similitude Theory to Calculation of Stripline Heating (Yu. Ya. Yurov; IZVESTIYA VYSSHIKH UCHEBNYKH ZAVEDENIY: RADIOELEKTRONIKA, No 8, Aug 83).....	55
Fundamentals of Radio Optical Theory of Resonant and Directional Quasi-Optical Devices (Yu. A. Pokrovskiy; IZVESTIYA VYSSHIKH UCHEBNYKH ZAVEDENIY: RADIOELEKTRONIKA, No 8, Aug 83).....	55
Waveguide Dielectric Millimeter Band Filter With Enhanced Selectivity (A. R. Bondarenko, V. I. May, et al.; IZVESTIYA VYSSHIKH UCHEBNYKH ZAVEDENIY: RADIOELEKTRONIKA, No 8, Aug 83)....	56
Calculating Dominant (Quasi-T) Mode Group Velocity in Shielded Microstrip Line (K. K. Valuyev, Yu. A. Ilarionov, et al.; IZVESTIYA VYSSHIKH UCHEBNYKH ZAVEDENIY: RADIOELEKTRONIKA, No 8, Aug 83).....	57
Study of Nonlinear Distortion in Microwave Amplifiers Using Schottky Gate Field Effect Transistors (M. V. Gromov, G. V. Petrov; IZVESTIYA VYSSHIKH UCHEBNYKH ZAVEDENIY: RADIOELEKTRONIKA, No 8, Aug 83).....	57
Photothyristor Optrons and Optron Microcircuits, Part 1 (RADIO, No 9, Sep 83).....	58

Multidiode Integrated-Circuit Protective Device
 (Ye. I. Kuptsov, V. P. Trofimov; IZVESTIYA VYSSHIKH
 UCHEBNYKH ZAVEDENIY: RADIOELEKTRONIKA, No 9, Sep 83).... 59

Microelectronics in Communications Equipment at 1983 Leipzig
 Spring Fair
 (V. I. Shlyapoberskiy; ELEKTROSVYAZ', No 10,
 Oct 83)..... 60

QUANTUM ELECTRONICS/ELECTRO-OPTICS

Pulsed Lasers for Filming Color Holographic Film Images
 (V. G. Komar, V. N. Sokolov; TEKHNIKA KINO I
 TELEVIDENIYA, No 9, Sep 83)..... 61

SOLID STATE CIRCUITS

Synthesis of Metrico-Topological Model for Layout of Topology
 of Large-Scale-Integration Arrays
 (V. M. Kureychik, V. A. Kalashnikov, et al.;
 MIKROELEKTRONIKA, No 4, Jul-Aug 83)..... 62

Synthesis of High-Speed Devices Using Integrated Operational
 Amplifiers
 (T. M. Agakhanyan; MIKROELEKTRONIKA, No 4, Jul-Aug 83)... 63

Characteristics of Optical Information-Measurement Channels
 With Utilization of Scattering Effects
 (S. I. Bychkov, V. N. Pavlov, et al.; IZVESTIYA
 VYSSHIKH UCHEBNYKH ZAVEDENIY: RADIOELEKTRONIKA, No 9,
 Sep 83)..... 64

SONICS AND ULTRASONICS

Binary Signal Detection in Acoustooptic Receivers
 (A. V. Pugovkin; IZVESTIYA VYSSHIKH UCHEBNYKH
 ZAVEDENIY: RADIOELEKTRONIKA, No 9, 1983)..... 65

Asymmetry of Diffraction Orders With Light Diffraction at
 Surface Acoustic Wave
 (V. B. Voloshinov, V. N. Parygin, et al.; IZVESTIYA
 VYSSHIKH UCHEBNYKH ZAVEDENIY: RADIOELEKTRONIKA,
 No 8, Aug 83)..... 69

Binary Detection of Signals in Acoustooptic Receivers
 (A. V. Pugovkin; IZVESTIYA VYSSHIKH UCHEBNYKH ZAVEDENIY:
 RADIOELEKTRONIKA, No 9, Sep 83)..... 70

NEW ACTIVITIES/MISCELLANEOUS

Mean Intensity of Wave Reflected by Wavefront Reversing Mirror in Turbulent Medium (A. N. Malakhov, A. V. Polovinkin, et al.; IZVESTIYA VYSSHIKH UCHEBNYKH ZAVEDENIY: RADIOFIZIKA, No 5, May 83).....	71
Thirty-Eighth Conference on 'Radio Day' (L. N. Ishutina; ELEKTROSVYAZ', No 9, Sep 83).....	72
Corrective Light Filters for Color Underwater Filming (M. G. Komolikov, A. M. Kuritsyn, et al.; TEKHNKA KINO I TELEVIDENIYA, No 9, Sep 83).....	72
Calculation of Surface Finish of Screen (V. I. Dybchinski; TEKHNKA KINO I TELEVIDENIYA, No 9, Sep 83).....	73

ON THE PRINCIPLE OF UNIFORMITY OF SATELLITE COMMUNICATIONS SYSTEMS

Moscow ELEKTROSVYAZ' in Russian No 10, Oct 83
(manuscript received 10 May 83) pp 23-26

KANTOR, L. Ya.

[Abstract] It is not clear whether the criterion of homogeneity for a satellite-to-earth link is to be considered as the equal power of the on-board transmitters of the potentially incompatible systems or equal power density at the boundary of the service area (as was used in the 1977 World Administrative Radio Conference). This paper is a detailed analysis of a system consisting of two satellites in geostationary orbit which service different areas, where the differences between them are such that the system 2 satellite has a more harmful impact on the system 1 earth station than does the system 1 satellite on the system 2 earth station. Crosstalk between the systems on the uplink is not considered here for the sake of simplicity, although the analysis can be readily extended to this case. The requisite condition for two such satellite systems being uniform is that the angular separation between the satellites of systems 1 and 2 from the standpoint of the effect of the interference of system 2 on system 1 is equal to the requisite separation from the standpoint of the effect of system 1 interference on system 2. This criterion is used as the basis for the derivation of quantitative expressions for the choice of the parameters of uniform systems. Analytical expressions are found for the ratios of the satellite transmitter powers as well as the ratio of the power flux densities at the surface. These equations are illustrated by the special case of relatively small and considerably separated service areas, where the satellite antenna directional pattern is in line with CCIR [International Radio Consultive Committee] 558-1 (mod. F), as well as the case of contiguous service areas. The crosstalk analysis in this paper makes it possible quantitatively to define the concept of satellite system uniformity and to estimate the degree of importance of this requirement; these considerations must be taken into account when selecting the parameters of efficient geostationary orbit utilization. Figures 4; references 8: 5 Russian, 3 Western (2 in Russian translation).
[50-8225]

INTERNATIONAL PROTOTYPE NETWORK IN 'DUBNA' EXPERIMENTAL SATELLITE COMMUNICATIONS SYSTEM

Moscow ELEKTROSVYAZ' in Russian No 10, Oct 83
(manuscript received 27 May 83) pp 27-32

BYKOV, V. L. (USSR), ALEKSANDROVA, Ye. (Bulgaria), BALABANOV, B. (Bulgaria), BAUER, V. (GDR), BERTO, Sh. (Hungary), VANTKE, K.-D. (GDR), VIT, I. (CSSR), KAVETSKI, A. (Poland), LIEBSCH, V. (GDR), SVYATOGOR, V. V. (USSR), SKONECHNY, V. (Poland) and YASTREBOV, I. A. (USSR)

[Abstract] The communications center of a prototype international satellite system using the 11 and 14 GHz bands has been in service for more than a year at Dubna in the USSR. The system is being constructed within the framework of the "Interkosmos" program by Bulgaria, Hungary, the GDR, Poland, the USSR and CSSR. The Dubna prototype system is intended for: 1) Comprehensive study of propagation conditions at frequencies above 10 GHz on ground and satellite links and the gain of several years of statistical data on depolarization and absorption in the atmosphere at these frequencies, as well as the distribution of precipitation rates and sky noise temperature and the determination of the correlations between these factors; 2) Estimating the impact of the atmosphere and weather conditions on data transmission via satellite links; 3) Testing new hardware for earth and satellite stations for broadcasting and communications. The prototype system is located 128 km north of Moscow, using three sites: Site 1 is at the existing international "Dubna" satellite communications center; Site 2 is 1 km from Site 1 in the direction of the "Luch-2" satellite; Site 3 is 12 km from Site 1 in the direction of the "Luch-1". Sites 2 and 3 are transmitting sites and signals from both are received at Site 1. To enhance the data storage reliability of the "Dubna" computer center, it is backed up by a similar center at Neu-Holm in the GDR. These two sites are linked through the "Statsionar-4" satellite via a duplex telephone channel used for data exchange. Technical specifications are given for the Class 1 and Class 2 stations in the system, as well as the ground test links using frequencies up to 30 GHz. The precipitation rate gauges are described and the equipment complement of the computer center for statistical data processing, designed around the Robotron 4201 computer, is detailed. Figures 7; tables 2.

[50-8225]

BASIC PROPERTIES AND INTERPRETATION OF SYNTHESIZED RADAR IMAGES OF SEA WAVES WITH LONG SYNTHETIZATION TIME

Gorkiy IZVESTIYA VYSSHIKH UCHEBNYKH ZAVEDENIY: RADIOFIZIKA in Russian
Vol 26, No 5, May 83 (manuscript received 11 Jun 82) pp 540-550

IVANOV, A. V., Institute of Radio Engineering and Electronics, USSR Academy of Sciences

[Abstract] Images of sea waves in a synthesized radar aperture, as well as their properties and interpretation, are analyzed by a method which yields an analytical expression for the shift of the optimum-focusing plane. The method, which in earlier studies was applied to the case of short synthetization time and yielded a close agreement with experimental data, is now extended to the case of long synthetization time. The basic properties of images are established for an ideal long sine wave propagating exactly parallel to the course of the radar carrier without regular variations of ripple (small-scale waviness) intensity relative to the wave phase. The wave image is assumed to have been produced by orbital motion (frequency modulation of backscattered radiation) only. Accounting for real conditions of large-scale waviness such as intensity modulation of backscattered radiation and finite width of the space-time spectrum would require many additional approximations. A more accurate and also simpler method, namely the two-frequency method, is proposed instead. It is based on the close analogy between synthesis of an aperture and matched filtration of scattered radiation during probing with linearly frequency modulated signals. The results reveal that elimination of the defocusing effect requires that the plane of optimum focusing shift, as the plane of the image of a point target moving along the course at a velocity equal to half the phase velocity of the wave or the albedo modulation envelope. The depth of albedo modulation at a given space frequency is determined, without measuring the velocity of the modulating wave, from the integral of the spectral density of the intensity product over Doppler-effect wave numbers. The results reveal further that the intensity of the reflected signal depends on the synthetization time and the correlation function, the only factor determining the smallest wavelength resolvable in the image being "life time" or "coherence time" characterizing the intrinsic motion of the Bragg component in the ripple. Figures 2; references 14: 3 Russian, 11 Western.

[64-2415]

MULTITRUNK HIGH-FREQUENCY MULTIPLEXING OF ANTENNA-WAVEGUIDE CHANNELS

Moscow ELEKTROSVYAZ' in Russian No 9, Sep 83
(manuscript received 28 Apr 82) pp 30-33

MODEL', A. M., STUZHIN, V. A. and SHKARINOV, Yu. S.

[Abstract] The number of powerful transmitters feeding into a common antenna-waveguide channel can be increased by nonresonance high-frequency multiplexing of that channel. Sequential pairwise combining of signals from the transmitters can be achieved either according to an amplitude-difference scheme or a phase-difference scheme. In the first case the ratio of amplitudes varies periodically with the frequency and tends to 1 as its geometric mean, while the phase difference remains exactly $+90^\circ$ or -90° . In the second case the difference of phases varies periodically and tends to 0 or 180° , while the ratio of amplitudes remains exactly 1. Nonresonance multiplexing systems feature a higher electric strength, a better structural decoupling of inputs, smaller phase distortions and lower insertion losses than resonance-type multiplexing systems with band separation or elimination filters. Here for illustration are described the design and performance characteristics of such a multiplexing system which combines signals from six 3 kW - 6 GHz transmitters, each operating within a 34 MHz band with a 50 MHz separation between center frequencies of adjacent bands. The system consists of three stages, the first two stages combining signals from transmitter pairs with respectively 200 and 100 MHz separation and the third stage combining signals from transmitter pairs with 50 MHz separation (transmitters in adjacent bands). Figures 8; references 4 (Russian). [61-2415]

METHOD OF CONSTRUCTING FOLDING UMBRELLA-TYPE ANTENNA

Kiev IZVESTIYA VYSSHIKH UCHEBNYKH ZAVEDENIY: RADIOELEKTRONIKA in Russian
Vol 26, No 8, Aug 83 (manuscript received after revision 11 May 82) pp 77-79

LOMAN, V. I. and GRYANIK, M. V.

[Abstract] Studies of the focusing properties of umbrella-type reflectors show that a redistribution of the field takes place towards the edges of the focal spot. This explains the poor efficiency when feed radiators with a point phase center are used in such antennas. If the reflector is configured with a shifted parabolic generatrix for the surface, and a feed irradiating system having partial phase center in the form of a ring is used, the phase errors can be compensated for to a considerable extent. Dual-reflector antennas with an elliptical, hyperbolic or parabolic generatrix of the sub-dish and a shifted parabolic axis for the large reflector have an annular phase center; thus, the construction of a folding umbrella-type antenna using one of these configurations will make it possible not only to realize the advantages of these antennas, i.e., significantly less shading of the aperture by the feed radiating system, reduction of the effect of the reflector on the feed radiator and the capability of fastening the reflector directly to the feed radiator, but also substantially to enhance its efficiency through more precise matching of the shapes of the partial phase center of the feed system and the focal region of the umbrella-type reflector. The efficiency of an umbrella-type antenna can be further improved by transforming the partial phase center of the feed radiating system into a polyhedron, similar to a focal polyhedral reflector. The design of a folding umbrella-type antenna using these ideas makes it possible to assure the requisite low losses in the gain without complicating the structural design, which has significantly fewer ribs than in an umbrella-type antenna with the same geometrid dimensions and the conventional configuration. Making the subdish in the form of a set of triangular cutouts with a surface which corrects the path of the rays allows for bringing the folding antenna close to an antenna having a reflector, which is an ideal paraboloid in terms of overall efficiency. Figures 3; references 4 (Russian).
[52-8225]

FREQUENCY INDEPENDENT PARABOLIC PHASED ANTENNA ARRAY OF LOG PERIODIC ANTENNAS

Kiev IZVESTIYA VYSSHIKH UCHEBNIKH ZAVEDENIY: RADIOELEKTRONIKA in Russian
Vol 26, No 8, Aug 83 (manuscript received 6 Apr 82) pp 72-74

VERIGA, B. A. and VYAKHIREV, N. I.

[Abstract] The design of frequency independent antenna arrays is based on the principle of electrodynamic similitude. If the antenna shape is completely defined in terms of angles and the principle of the transition from an infinite structure to a structure of finite dimensions applies, the system retains electrodynamic similitude with any change in the working frequency. A configuration which satisfies these requirements is a phased antenna array consisting of radial log periodic radiators characterized by the same similitude coefficient. The vertices of all the radiators converge towards a single point, the center of the array. The special case of identical log periodic radiators positioned with a uniform radial angular spacing is known as a Duhamel array. A drawback to this structure is the necessity for using phase shifters at the inputs to the antennas to shape the main lobe. This paper circumvents the problem by arranging the radial log periodic radiators to form a parabolic phase array, where the dipoles of equal size for all of the elements are positioned on the parabolic line. The array can be made, both with symmetrical log periodic radiators in free space, and with inclined radiators with vertical polarization positioned above a conducting surface. The actual performance of such a parabolic phased array with inclined log periodic dipoles was studied: the antennas were placed over a flat metal screen; they had a similitude coefficient of 0.9, an angle at the vertex of the central log periodic radiator of 0.2 rad; the characteristic impedance of the distribution feedline was 180 ohms; the ratio of the radius of the shortest dipole to the length of its arm was 0.01; and the output impedance of the excitation sources was 120 ohms. Two numerical experiments established the optimum characteristics of the parabolic phased array. The first experiment used a six-element array and varied the angular spacing between them. The second varied the number of antennas in the array while the angular aperture remained constant at 90°. The maximum gain in this case was achieved with five or six elements, corresponding to an angular spacing of 22.5 or 18°. The back radiation was less than -20 dB. A promising application of such arrays is for feed radiators in parabolic reflectors. Their advantages include a frequency coverage factor of 10 and more, and a multiple element feed radiator of log periodic elements can easily produce a narrow directional pattern where the feed radiator dimensions are substantially less than the dimensions of a horn with ribbed walls. The phase center of such an antenna feed radiator is in front of it, which is desirable in some cases. Figures 3; references 3: 1 Russian, 2 Western (1 in Russian translation),

[52-8225]

MINIMIZING FIELD SCATTERED BY SLENDER DIPOLES

Kiev IZVESTIYA VYSSHIKH UCHEBNYKH ZAVEDENIY: RADIOELEKTRONIKA in Russian
Vol 26, No 8, Aug 83 (manuscript received after modification 17 Jan 83)
pp 48-53

PONOMAREV, L. I. and DOLGIY, A. V.

[Abstract] The problem of minimizing the field scattered by a single dipole or dipole array is characteristic of dual-frequency antenna arrays colocated in a single aperture, where one of the arrays is a dipole array and is positioned above the other. It is also characteristic of efforts to reduce the effective scattering surface area of dipole antennas. The paper solves the problem of reducing dipole antenna scattering by means of active suppression. This is accomplished by feeding to those dipoles on which the external electromagnetic field impinges, an energy at the same frequency as the incident field via additional feed circuits. A reduction in the overall current induced in the dipoles can be achieved in the additional feed circuits by the appropriate choice of the amplitude and phase of the excitation. The formulation of the problem of such excitation is simplified by using simulation in the form of several e.m.f. sources connected to the dipole sections through matched circulators and feed lines with a specific characteristic impedance. An algorithm is derived for the choice of the optimal values of the e.m.f.'s and the results of a confirming numerical analysis are shown graphically. The algorithm makes it possible to determine both the requisite number of inserted e.m.f. sources and the optimal excitation, as well as the level of optimal scattered field suppression. The minimum scattered field level is governed not only by the number of inserted e.m.f. sources, but also by their noise level. Figures 3; references 2 (Russian). [52-8225]

MODERNIZATION OF THIRD GENERATION TV EQUIPMENT

Moscow TEKHNIKA KINO I TELEVIDENIYA in Russian No 9, Sep 83 pp 37-45

PALITSKIY, V. M.

[Abstract] On the basis of the technical assignments of USSR Gosteleradio [State Television and Radio], Soviet industry has widely expanded work with respect to the creation of third generation television and sound equipment for use inside and outside a studio, in which digital processing of signals will be assured. At the same time, the output of third generation equipment and the reconstruction of the technical base of Soviet television under way accomplish further improvement of studio equipment in the course of series output. In the middle of 1983, at 90 of the 120 television stations in the USSR, it was already possible to one or another extent to produce color TV programs. Modernization of TV techniques not requiring considerable expenditures on fundamental investigations is a sufficiently effective means of improvement of the operating characteristics and an increase of the technical quality of TV broadcasting. In February 1979, the Scientific-Technical Council of USSR Gosteleradio, considered the result of an introduction of third generation TV equipment into the television stations of the USSR and outlined the basic directions for its improvement, which subsequently was shaped into concrete technical requirements for various types of equipment. In 1980-1983 work on modernization was expanded in accordance with these requirements. The following items concerned with the above work are briefly described in the paper: 1) Development of domestic gletikons (transmitting tubes for three and four tube color studio cameras) with a diode gun, and modernization of the KT-132 studio camera; 2) Development of individual units and devices for modernization of control room-studio units and mobile TV stations; 3) Modernization of television-motion picture equipment for showing color motion picture films on a base of the KT-132 camera; 4) "Kadr-3PM" video tape recorder; 5) Series MEZ-102 sound tape recorder; 6) "Etyud" mobile TV station with video recording; 7) PVMA mobile video tape recorder; 8) Modernized mobile TV station "Magnolia-83". Figures 10.

[62-6415]

PROSPECTS FOR USING MICROPROCESSORS IN PROFESSIONAL VIDEO TAPE RECORDERS

Moscow TEKHNIKA KINO I TELEVIDENIYA in Russian No 9, Sep 83 pp 45-47

LAPSHOV, N. N., All-Union Scientific-Technical Institute of Television and Radio Broadcasting

[Abstract] The paper is concerned with the use of microprocessors in video recording, particularly in professional video tape recorders. The merits and shortcomings of these items are discussed. Three basic variations of the structure of video tape recorders based on microprocessors are considered: 1) Many processor system; 2) Multiprocessor system. (This system preserves the advantages of the many processor system. However, all the systems of the video tape recorder are unified in one system controlled by a single program.); 3) Microelectronic computer for control of video tape recorders. Figures 4; references 3: 2 Russian, 1 Western.
[62-6415]

UDC 778.5:621.397.13

MOBILE VIDEO TAPE RECORDER EDITING ROOM

Moscow TEKHNIKA KINO I TELEVIDENIYA in Russian No 9, Sep 83 pp 54-56

BARANOV, O. P., NELIPA, V. I. and STARKIN, G. N., Kirovogradsk Radio Products Plant

[Abstract] Five forms of mobile videorecording stations (PVS) have already been developed in the USSR: 1) the PTMZ with a "Kadr-1" video tape recorder; 2) the PVS1 with a "Kadr-3" video tape recorder; 3) The PVS-3 and PVS-4 with a "Kadr-3P" video tape recorder; and 4) The mobile video recorder equipment vehicle "Plato" developed in 1978 with two "Kadr-3P" video tape recorders and the apparatus for semiautomatic electronic editing. The paper describes a new unit, the PVMA mobile video tape recorder editing room developed in 1982, which uses the standardized international code SMPTE. This new equipment made it possible to eliminate certain shortcomings in other units. A block diagram and the composition of the equipment used in the PVMA are presented, as well as a general view of the unit. Figures 3.
[62-6415]

TRANSMITTER SPECTRUM ANALYZER

Moscow RADIO in Russian No 9, Sep 83 pp 17-21

STEPANOV, B. (UW3AX) and SHUL'GIN, G. (UA3ACM), Moscow

[Abstract] A spectrum analyzer for 7 MHz single-sideband transmitters of two tone signals at 1 and 1.8 kHz, respectively, on a 14,200 kHz carrier, has been developed at the RADIO Journal in-house laboratory, as a means for monitoring the amplifier linearity and the intermodulation level. The instrument includes an adjustable attenuating resistor, a resistive decoupler, a ring mixer (KD503 or equivalent high-frequency silicon diodes) separated from the heterodyne stage (quartz oscillator and KP302 or KP303 field-effect transistor) by an emitter follower (KT312 or KT606 transistor), two low-pass filters (LC filter and second-order active filter using an operational amplifier), a low-frequency a.c. millivoltmeter using an operational amplifier, a transformer (PEV-2/0.3 wire on ferrite ring core), a 50-200 μ A microammeter, and a light-emitting indicator diode. Adjustment of the analyzer for operation begins with checking the performance of transistors in the d.c. mode, followed by trimming a LED resistor for threshold-sensitivity current, applying an audio signal, and oscillographically recording the amplitude-frequency characteristic, then applying a high-frequency signal from a standard oscillator for millivoltmeter and microammeter calibration. The test equipment for analyzing the spectrum of single-sideband transmitter signals includes a generator of two-tone signals, an antenna equivalent, and an oscilloscope, the latter in parallel with the spectrum analyzer. Figures 5; tables 1; references 3: 2 Russian, 1 German. [59-2415]

MODULE FOR INTERFACING MICROPROCESSORS AND MICROCOMPUTER

Moscow RADIO in Russian No 9, Sep 83 pp 32-35

ZELENKO, G., PANOV, V. and POPOV, S.

[Abstract] A module has been developed for interfacing a digital magnetic sound recorder to a microcomputer so as to match a recording density of 32 bit/mm and a recording rate of 1500 bit/s. It has been designed for use with "Romantik-306" recorders and MK-60-2 cassettes, but is also suitable for any other similar monophonic or stereophonic cassette-type recorders. Data are recorded on tape sequentially by the method of two-phase encoding. Data are played back by decoding, which involves bit identification and storage with program delay between processing of successive bits. The integrated microcircuit hardware of the module includes a pulse shaper (K589AP2B) coupling it to the data busbar at the last digit, an address decoder (K155LA2 and K155LYe1), a D-trigger (K155TM2), an inverter (K155LYe1) and a low-pass filter for recording, a low-pass filter and an operational amplifier (K140UD7) forming rectangular +5 V pulses with a clipping (rectifying) diode at the output for reading into the microcomputer.

The software ensures conversion of incoming bytes from parallel to series form for sequential input to trigger, then encoding of each bit and formation of corresponding time intervals. It includes several subprograms such as "call mag. rec." (ZPMAG), "exclude OR" (ZADRO5), "read mag." (ChTMAG), and "delay program" (ZADR75). The module is structurally very simple and operationally highly reliable. Figures 7.

[59-2415]

UDC 621.397.13

FEASIBILITY OF USING PASSIVE TELEVISION RELAYING DEVICES

Moscow ELEKTROSVYAZ' in Russian No 9, Sep 83
(manuscript received 30 Nov 82) pp 13-14

KUZNETSOV, V. D.

[Abstract] Passive television relaying devices can be built either in the form of plane reflectors constituting a grid of parallel conductors with a high reflection coefficient or in the form of phased arrays, two arrays of antennas. In the first of three configuration variants the angle between direction of the incoming signal and that of the relayed signal is larger than 90° . In the other two variants, with a small angle between these two directions in both, either the refraction angle is larger than 90° in each type of relay or the entire aperture surface is effectively utilized. The efficiency of any relaying device is defined as the ratio of electric field intensity at a given reception point to electric field intensity at the relay location. This ratio is calculated from the known relay input power and relay orientation, assuming equal aperture areas at relay input and output. The width of the major lobe as well as that of successive side lobes and especially the first one in the radiation pattern of a relay can be calculated from the aperture dimensions, the aperture being usually either rectangular or rhombic. The design of a television relay begins with determining the field which the television center produces at the relay location, the distance from relay to center of the service zone, and the angle between the direction from television center to relay and the direction from relay to center of the service zone. The design is based on given performance requirements. As an illustrative example are shown calculations leading to the design of a reflector-type relay for television channel X (199.25 MHz) at a distance of 1000 m from the television center with a field intensity of 6 mV/m at that location. Both wire size and conductor spacing are determined, also the aperture dimensions. Figures 2; references 1 (Russian).

[61-2415]

PREDICTING ELECTRICAL PERFORMANCE PARAMETERS OF UNDERWATER CABLES

Moscow ELEKTROSVYAZ' in Russian No 9, Sep 83
(manuscript received, after completion, 20 May 81) pp 39-42

ARKHANGEL'SKIY, G. A.

[Abstract] Changes in the electrical performance parameters of underwater coaxial cables are predicted on the basis of the cable design parameters and the results of simulation tests. The procedure is demonstrated on a coaxial pair which had been designed with a compact dielectric filler and held four months in a laboratory tank under conditions simulating those at the sea bed, then reconstituted for further use. Increments of capacitance and the attenuation coefficient and decrements of inductances and the characteristic impedance are determined, with the aid of handbook reference data and taking into account the temperature factor. In the process are also determined the resistances of the cable conductors and the dielectric permittivity of the filler, according to standard relations. The accuracy of this algorithm is determined by and estimated as a function of measurement errors and dimensional errors. The error in the predicted increment of the attenuation coefficient, for instance, increases proportionally with the error of capacitance measurement and decreases with increasing gap between dielectric filler and outer conductor. It thus depends on the main error and the temperature error of three measurements: capacitance and diameters of both cable conductors. Figures 4; references 4 (Russian).
[61-2415]

SPECIAL FEATURES OF TRANSMITTER TUNING

Moscow VESTNIK SVYAZI in Russian No 10, Oct 83 pp 32-33

YEMEL'YANOV, V. K., senior engineer, Kiev branch, Scientific-Research Institute of Radio Engineering

[Abstract] Video and audio transmitters in TRSA-12/12 television relay stations must be tuned prior to operation and after each overhaul. The audio transmitters are tuned, stage-by-stage strictly according to their technical description, but in the same way as the last audio stage: into an equivalent load and an antenna. It is either not permissible to change any connection between modules and to adjust the band elimination filters during tuning, or it is necessary to measure, after tuning, the positions of all modules and links which determine the interstage coupling relative to the fixed module (back wall). Tuning must include the neutralization circuit of the GU33B transmitter, and its grid circuit at the same time until both are in tune simultaneously. Tuning is also done after each tube replacement. Long cable lines are regularly disassembled and cleaned, with

a pencil eraser or with alcohol, as preventive measure. Following the recommended tuning procedure by qualified personnel has been found to greatly improve the operational indices of type TRSA-12/12 relays.
[60-2415]

DEVICE FOR COMBINING SIGNALS FROM TELEVISION TRANSMITTERS INTO COMMON ANTENNA FEEDER SYSTEM

Moscow VESTNIK SVYAZI in Russian No 10, Oct 83 pp 37-39

BOBYLIN, V. L., senior engineer, production laboratory, Regional Administration of Radio and Television Broadcasting, Latvian SSR Ministry of Communications

[Abstract] Several devices have been developed which make it possible to combine signals of two television programs for more efficient transmission over a common antenna feeder system, so that only one antenna will suffice or the second antenna can be made available for a third program. Such a device consists of two high-frequency band-separation filters covering the audio transmitter and the video transmitter in one channel, and a set of three directional couplers combining the signals from two stations. Each filter contains a twin-square bridge with coaxial cable segments as arms, two resonators, each comprising two branches of open-end coaxial lines, and a ballast load. All components are designed for a nearly rectangular amplitude-frequency characteristic of the device and an appropriate voltage traveling-wave ratio, with allowance for manufacturing variation and permissible losses. Measurements and tuning after assembly are done with standard instruments which include a frequency-response characteristic meter, a high-frequency oscillator, a frequency meter with frequency division, a millivoltmeter with 3-way joints, and a set of 75-ohm matched loads. Filters of this design and a "Kvadrat" directional coupler have been operating five years in channels VI and X with two RTsTA-70 radio relay links and a band-III panel antenna (made in Czechoslovakia) through a "Vacha" cable, also with two RTsTA-70 radio relay links and a turnstile antenna. Experience indicates high stability and reliability of these devices, an almost doubling of the area of the television reception zone. Figures 8; tables 2.
[60-2415]

SOME DEVELOPMENTAL TRENDS IN TELEVISION BROADCASTING SYSTEMS

Moscow ELEKTROSVYAZ' in Russian No 10, Oct 83
(manuscript received 12 Jul 83) pp 18-22

VARBANSKIY, A. M.

[Abstract] A brief review of the historical development of TV broadcasting in the USSR is followed by a discussion of present and possible future TV systems. The existing USSR television broadcasting network consists of more than 450 high power TV transmitting stations and 4,000 low power stations. Television programs utilize hundreds of thousands of kilometers of ground TV links, eight satellite channels, up to 90 "Orbita" satellite receiving stations, 2,300 "Ekran" receiving stations and 100 "Moskva" stations. This network covers about 90% of the nation's population with TV broadcasts and 69% of the population lives within range of two programs. The populace has more than 80 million TV receivers, including 8 million color sets. Direct satellite broadcasting is not yet feasible due to the inordinate power requirements and antenna dimensions needed for the satellite transmitters. The prospects for high resolution TV systems using about 1,200 lines instead of the 625 line present Soviet standard are limited only by the elevated bandwidth requirements. This will necessitate the use of satellite channels in the 12 GHz and higher bands; direct home use of high resolution TV is not under consideration at the present time. It is anticipated that the development of digital technology and microelectronics will make it possible to transmit several audio programs simultaneously with the TV programming, including such services as "Teletext" and subtitles. A figure shows the distribution of programs of Central television, Figures 1.
[50-8225]

RSFSR CONFERENCE ON IMPROVING QUALITY AND RELIABILITY OF LOW-POWER TELEVISION REPEATER OPERATION, RESULT OF ALL-RUSSIAN CONFERENCE

Moscow ELEKTROSVYAZ' in Russian No 10, Oct 83 pp 42, 57, 64

GORMAKOVA, N. I. and YUSHKIN, A. I.

[Abstract] In May 1983 at Miass, the Main Radio Administration of the RSFSR Ministry of Communications in conjunction with the Urals House of Scientific and Technical Publicity, the Chelyabinsk Oblast Directorate of the Scientific and Technical Society of Radioengineering and Telecommunications imeni A. S. Popov, and the Chelyabinsk Oblast Operational Engineering Communications System Administration, held an all-republic RSFSR conference on improving the operational quality and reliability of low-power radio and TV transmitting stations. At the beginning of 1983, 88.7% of the population of the RSFSR was covered by TV service, including 95.7% of the urban populace and 71.4% of the rural. It is planned that 80% of the rural population will

have TV service by the end of 1985. To accomplish this, it is necessary to bring a large number of low- and high-power transmitting stations on line. The conference participants, who discussed this problem along with the dissemination of experience by the personnel of operating enterprises, were representatives of the RSFSR Ministry of Communications, the communications ministries of the union republics, scientific research and teaching institutes, factory representatives from plants producing TV repeaters and operational personnel from RSFSR communications enterprises. The participants numbered about 150. To further enhance reliability and efficiency, the conference agreed that: 1) The development of a comprehensive program for 1983-1990 to modernize the low-power repeater network should be accelerated; 2) Recommendations for boosting the output power and stability of the qualitative indicators of the RTsTA-70 TV repeater should be implemented in the RSFSR TV network; 3) Power combining systems for feeding the video and audio of low-power repeater transmitters into a single antenna should be introduced as well as power combining bridges for transmitters on different channels using one antenna; 4) Standardized modulators should be used, where these have a video equalizer for all types of TV transmitters; and 5) A council of the leading specialists from the operational enterprises should be set up to resolve questions of coordination and standardization of all equipment modernization efforts in the sector, under the supervision of the RSFSR Main Radio Administration.

[50-8225]

DESIGN OF DIGITAL BANDPASS FILTERS WITH FINITE MEMORY

Kiev IZVESTIYA VYSSHIKH UCHEBNIKH ZAVEDENIY: RADIOELEKTRONIKA in Russian
Vol 26, No 9, 1983 (manuscript received 25 Oct 82 after revision) pp 3-9

[Article by V. V. Vityazev, S. I. Murav'yev and A. I. Stepashkin]

[Text] A method of designing digital bandpass filters with finite pulse characteristic, based on two- and multistage structures of digital comb filters, is proposed. The relationships between the parameters of the stages that permit minimization of the total calculating expenditures are found.

One of the important aspects of digital signal processing theory (TsOS) is the range of problems related to development and investigation of the methods of design of digital frequency-selection or digital bandpass filters (TsPF), which find broad application in modern information measuring systems and communication and control systems [1, 2]. With regard to the appearance and the increasing practical use of microprocessors and microprocessor BIS [large-scale integrated circuit], the development of new effective methods of designing digital bandpass filters takes on especially timely significance.

The problem of linear digital frequency selection of signals, formulated in rather general form, assumes the search in some class of digital circuits for that circuit structure which would provide the necessary accuracy of reproduction of the desired transfer function (the universe of amplitude-frequency (AChKh) and phase-frequency (FChKh) characteristics) of the filter with minimum hardware and computer expenditures for realization of the corresponding digital signal processing device. An example of the typical amplitude-frequency characteristic of a bandpass filter $H(\omega)$ ($\omega = \omega T$ is the reduced angular frequency and T is the quantification period of the input process), located in the tolerance band $(\epsilon_{1d}, \epsilon_{2d})$, is given in Figure 1. Here $\bar{\omega}_0$ is the central frequency, $\bar{\omega}_{s1}$ and $\bar{\omega}_{s2}$ are the cutoff frequencies that separate the bandpass and the attenuation band of the amplitude-frequency characteristic of the filter of the transition zone and ϵ_{1d} and ϵ_{2d} are the permissible irregularity of the amplitude-frequency characteristic in the bandpass and the attenuation band, respectively. If the supplementary conditions are the linearity of the phase-frequency characteristic and the capability of operational reproduction of the required amplitude-frequency characteristic of the filter, then the effective structure of the digital bandpass filter is found in the class of digital circuits with finite pulse characteristic or abbreviated KIKh-circuits [1], also known as finite memory circuits (filters).

The increased interest in development and investigation of methods of designing KIKh-filters arose with regard to the appearance of the algorithm of high-speed convolution on the basis of the double fast Fourier transform (PPF) [1] and the frequency sampling method [3]. As shown in [4], the use of methods based on the algorithm of the fast Fourier transform and frequency sampling with respect to design of narrowband filters leads to an appreciable increase of the hardware expenditures, due to the large memory capacity and the need for high-precision representation of the filter coefficients. Methods of design of digital bandpass filters on the basis of secondary quantification (decimation) and interpolation of the readings of the output signal, which are distinguished by high effectiveness in realization of narrowband filters, are considered in [5, 6, 7]. However, a number of deficiencies, related to the appearance of specific components of natural noise--secondary quantification noise and interpolation error [6, 7], is inherent to methods based on secondary quantification, which limits the possibility of widespread use of them. The disadvantages of the method of [5] should also include the large memory capacity of the filter coefficients (the memory of readings of the pulse characteristic) and the comparatively high natural noise level. Thus, further development of new methods of design of KIKh-filters is timely.

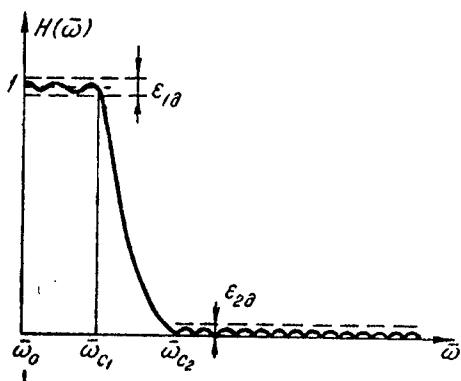

Figure 1

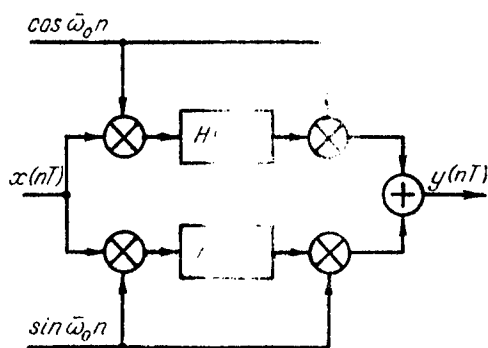

Figure 2

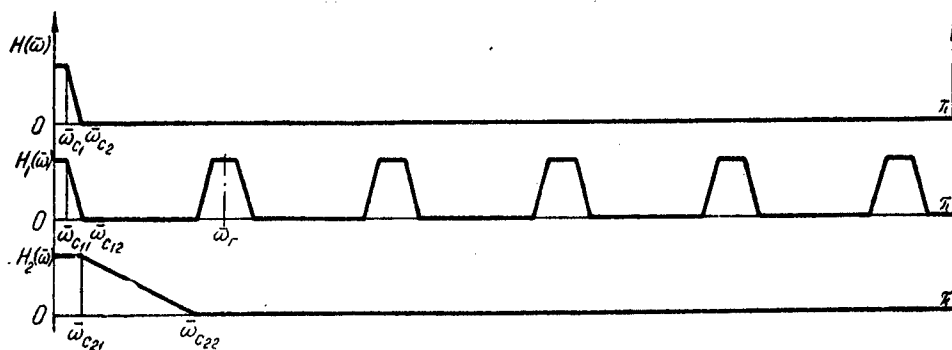

Figure 3

The method of designing narrowband filters with finite memory based on two- and multistage structures of digital comb filters is proposed below.

TWO-STAGE REALIZATION OF NARROWBAND KIKh-FILTERS. Let it be required to design a digital bandpass filter operating in real time in the frequency range of $0 \leq \bar{\omega} \leq \pi$ and corresponding to the frequency selectivity properties given above (Figure 1) with respect to the central frequency $\bar{\omega}_0$. To design a filter operationally tunable by the central frequency, let us use a structure with quadrature modulation (Figure 2), which makes it possible to reduce the design of a bandpass filter to design of an equivalent low-frequency filter (NCh-filter) in the sense of the required frequency selectivity properties [8]. Therefore, let us subsequently limit ourselves to design of the effective structure of an NCh-filter, i.e., let us use $\bar{\omega}_0 = 0$.

Let us represent the low-frequency filter to be designed with the desired transfer function (Figure 3) in the form of a series connection of a digital comb filter (TsGF) with periodic frequency characteristic $H_1(\bar{\omega})$, the components of which repeat new-fold the properties of the frequency selectivity of the initial filter in the range of working frequencies $\bar{\omega} = -\pi, \pi$, and of a digital smoothing filter (TsSF) with transfer function $H_2(\bar{\omega})$, which separates the major lobe located in the vicinity of frequency $\bar{\omega}_0 = 0$ from the universe of lateral components at the output of the digital comb filter. The question arises of what advantage conversion to a two-stage structure yields? Since ν zero readings are required per reading of the pulse characteristic of the digital comb filter, distinct from zero, realization of the input filter requires $1/\nu$ fewer arithmetic operations per unit time than non-stage realization of the initial low-frequency filter. In this case the expenditures for realization of the smoothing filter are less, the less the value of the cutoff coefficient, due to the capability of reducing the order of magnitude of the digital smoothing filter as the relative bandwidth and the transition zone of its amplitude-frequency characteristic increase. Thus, the problem of optimization of the two-stage structure, formalization and solution of which permit one to evaluate the effectiveness of the proposed method, arises.

Let us use the number of multiplication operations during the quantification period T , as in [4], as the estimate of the calculating expenditures. Let N_1 and N_2 be the order of the digital comb and smoothing filters, respectively. The required number of multiplication operations for realization of the considered two-stage structure will then comprise

$$V_1 = N_1/\nu + N_2. \quad (1)$$

To find the optimum value of parameter ν that minimizes the total calculating expenditures (1), let us first use the universe of relations that link the orders N_1 and N_2 to the parameters of frequency selectivity $\alpha_1, \beta_1, \alpha_2, \beta_2, \epsilon_{1d}$ and ϵ_{2d} of the digital comb and smoothing filters [6]:

$$N_1 = \alpha_1 \beta_1 L_1 \left(\frac{\epsilon_{1d}}{2}, \epsilon_{2d} \right) \quad \text{and} \quad N_2 = \alpha_2 \beta_2 L_2 \left(\frac{\epsilon_{1d}}{2}, \epsilon_{2d} \right), \quad (2)$$

where $\alpha_1 = \bar{\omega}_{c11} / (\bar{\omega}_{c12} - \bar{\omega}_{c11})$ is the orthogonality index and $\beta_1 = 2\pi / \bar{\omega}_{c11}$ is the narrowband index of the components of the amplitude-frequency characteristic of a comb filter and $L_1(\epsilon_{1d}/2, \epsilon_{2d})$ are the width of the transition zone of its frequency components, expressed by the number of quantification periods by frequency $\bar{\Omega} = 2\pi/N_1$. The parameters α_2 , β_2 and $L_2(\epsilon_{1d}/2, \epsilon_{2d})$ have the same meaning, but with respect to the amplitude-frequency characteristics of a digital smoothing filter. It is assumed that it is sufficient to introduce the constraint $\epsilon_{1d}/2$ on the non-uniformity of the amplitude-frequency characteristic in the bandpass of digital comb and smoothing filters to reproduce the desired frequency characteristic with given accuracy ϵ_{1d} in the bandpass of two-stage connection of filters.

Let us note that the parameters α_1 and β_1 for a digital comb filter are strictly fixed and are determined by the required properties of frequency selectivity (parameters α and β) of the finite pulse characteristic-filter to be designed: $\alpha_1 = \alpha$ and $\beta_1 = \beta$, whereas the selection of parameters α_2 and β_2 is arbitrary for a digital smoothing filter. In this case the cutoff coefficient ν is linked to parameters α_2 and β_2 by the expression

$$\nu = \frac{2\pi}{\bar{\omega}_r} = \frac{2\pi}{2\bar{\omega}_{c21} + (\bar{\omega}_{c22} - \bar{\omega}_{c21})} = \frac{\alpha_2\beta_2}{1 + 2\alpha_2}. \quad (3)$$

Thus, the cutoff coefficient ν is in the general case a function of two variable values-- α_2 and β_2 . However, it follows from simple logic arguments that its bandwidth is $\omega_{c21} = 2\pi/N_2$ for the minimum permissible order N_2 of a smoothing filter. In this case the width of the transition zone of the amplitude-frequency characteristic of a digital smoothing filter is $\bar{\omega}_{\pi 22} =$

$= \frac{2\pi}{N_2} L_2(\epsilon_{1d}/2, \epsilon_{2d})$ and the parameter

$$\alpha_2 = 1/L_2(\epsilon_{1d}/2, \epsilon_{2d}). \quad (4)$$

Having substituted expressions (2), (3) and (4) into (1), with regard to the assumption $L_1(\epsilon_{1d}/2, \epsilon_{2d}) = L_2(\epsilon_{1d}/2, \epsilon_{2d}) = L(\epsilon_{1d}, \epsilon_{2d})$, which usually occurs (6), we find

$$V_1 = \alpha\beta L/\nu + (2 + L)\nu. \quad (5)$$

Having taken the derivative of the right side of expression (5) with respect to ν and having solved the equation $dV_1/d\nu$, we find the optimum value of the cutoff coefficient

$$\nu_{opt} = \sqrt{\alpha\beta L/(2 + L)}. \quad (6)$$

The minimum calculating expenditures for realization of a two-stage structure of a low-frequency filter for the optimum value of parameter ν will comprise

$$V_1(\nu_{opt}) = 2\sqrt{\alpha\beta(2 + L)L}. \quad (7)$$

No additional restrictions on the range of the permissible values of parameter ν whatever were placed in derivation of expression (6). Direct use of formula (6) for sufficiently large values of parameter α may lead to those values of

the cutoff coefficient ν and accordingly of the narrowband index of a digital smoothing filter $\beta_2 = (2 + L)\nu$, for which $\beta_2 > \beta_1$, which is impermissible from physical concepts (Figure 3). Therefore, the boundary condition $\nu \leq \frac{\beta_1}{2 + L}$ must be taken into account when selecting the cutoff coefficient.

To estimate the effectiveness of the proposed structure with respect to non-stage realization of a low-frequency filter, let us use the efficiency index [4]:

$$\vartheta_1 = \frac{V}{V_1} = \frac{1}{2} \sqrt{\frac{\alpha\beta L}{2+L}} = \frac{1}{2\sqrt{2+L}} \sqrt{N},$$

where $V = N = \alpha\beta L(\epsilon_{1d}, \epsilon_{2d})$ is the number of multiplication operations for realization of a low-frequency filter of order N by the ordinary method.

Thus, the effectiveness of the proposed method is proportional to \sqrt{N} and lies in the range of several tens and hundreds of units for narrowband finite pulse characteristic filters, when the order of N reaches thousands and tens of thousands of units. In this case, unlike the modified direct convolution method [4, 5, 6], which has a comparable efficiency index, the proposed method of design does not include a supplementary noise source--an error determined by the effect of secondary quantification and subsequent interpolation. Moreover, the dimensionality of the data arrays to be processed at the inputs of digital comb and smoothing filters decreases in proportion to \sqrt{N} , in the first case due to use of a "cutoff" pulse characteristic of the initial low-frequency filter and in the second case due to a reduction of the order of the smoothing filter with respect to the order of the filter to be designed.

Accordingly, the level of deviation of natural noise both at the output of the digital comb filter and at the output of the digital smoothing filter is $1/\sqrt{N}$ as much and, taking the smoothing properties of the output stage of filters into account, one can state that the natural noise at the output of a two-stage structure will be determined mainly by the component of the output stage with identical dimensionality of the data arrays at the inputs of digital comb and smoothing filters.

Let us also note that the ROM capacity of readouts of the pulse characteristic of a digital comb filter decreases in proportion to the cutoff coefficient. At the same time, the memory capacity increases by a value proportional to the order N_2 of the output smoothing filter and comprises an insignificant part of the total memory capacity of input data of a comb filter ($N_2 \ll N$).

MULTISTAGE REALIZATION OF NARROWBAND FINITE PULSE CHARACTERISTIC FILTERS.
Analysis of the characteristic features of the two-stage structure of a narrowband filter presented above shows that the calculating expenditures for realization of the corresponding comb filter decrease as the cutoff coefficient increases. However, the narrowband index of a smoothing filter β_2 , its order $\sqrt{N_2}$ and as a result the expenditures for realization increase as parameter ν increases. However, the calculating expenditures for realization of a narrowband digital smoothing filter can be reduced approximately $1/\sqrt{N_2}$ if one uses a two-stage structure similar to the method considered above. If the

output digital smoothing filter of a three-stage structure is narrowband, then the process of an effective increase of the number of stages may continue even further.

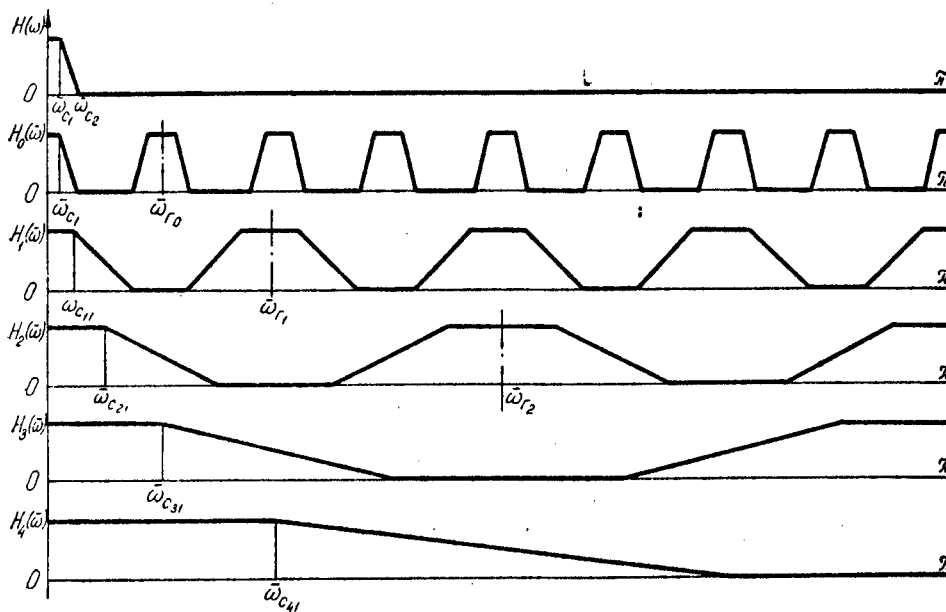

Figure 4

To utilize the illustration presented in Figure 4, let us consider the idea of designing an effective multistage structure of a narrowband low-frequency filter. As before, let $H(\omega)$ be the desired transfer function of the filter to be designed and let β and α be the narrowband and orthogonal index, respectively, of its amplitude-frequency characteristic. Let us use a comb filter $TsGF_0$, the major lobe of the transfer function $H_0(\bar{\omega})$ of which coincides with transfer function $H(\bar{\omega})$ of the filter to be designed, as the input filter of a multi-stage structure and let us use the repetition rate of the side lobes $\bar{\omega}_{p0} = \omega_{s1}^{-1}$, which corresponds to a value of the cutoff coefficient of readings of the pulse characteristic of the initial filter

$$v_0 = 2\pi/8\bar{\omega}_{c1} = \beta/8. \quad (8)$$

Let us use a R -stage structure of comb filters $TsGF_i$, $i = \overline{1, R}$, where $R = \log_2 v_0$ with pulse characteristics of the same type, to separate the major lobe of the transfer function $H_0(\bar{\omega})$ from the universe of v_0 lateral components at the output of the filter $TsGF_0$. Each filter $TsGF_i$ uses the same sequence of readouts of the pulse characteristic, but the repetition rate of these readouts upon transition to the next filter $TsGF_{i+1}$ is $1/2$ as much. Accordingly, the length of the pulse characteristic of each subsequent filter is $1/2$ as much, which leads to proportional expansion of the bandpass and of the transition zone of the components of the amplitude-frequency characteristic of digital comb filters as ordinal number i increases. In this case the first filter of the R -stage structure ($TsGF_1$), having suppressed all odd lateral components at the output of comb filter $TsGF_0$ with the required frequency selectivity (ε_{2d}), distinguishes only the universe of even components. The

TsGF₂ filter in turn separates the universe of even components at the output of comb filter TsGF₁, while filter TsGF₃ distinguishes the universe of even components at the output of filter TsGF₂ and so on. Finally, the last stage separates the major lobe from the only one of the remaining lateral components --the component located in the vicinity of frequency $\bar{\omega} = \pi$ (Figure 4).

To illustrate the effectiveness of the proposed multistage structure, let us first find the estimate of the required number of multiplication operations for realization of R-stage connection of comb filters of the same type. Since the calculating expenditures for realization of the same typical comb filter, the orthogonality index of the amplitude-frequency characteristic of the frequency components of which is taken as equal to $\alpha_1 = 0.5$ (provided that $\alpha \geq 1$) for all values of $i = \overline{1, R}$ and since the cutoff coefficient v_i is related to the corresponding narrowband index β_i by the relation $\beta_i = 8 \cdot \frac{1}{v_i}$, comprise

$$V_i = \alpha_i \beta_i L_2[\varepsilon_{1R}/(R+1), \varepsilon_{2R}] / v_i = 4L_2[\varepsilon_{1R}/(R+1), \varepsilon_{2R}],$$

then we present the required number of multiplication operations for realization of a R-stage structure in the form $V_R = 4L_2[\varepsilon_{1R}/(R+1), \varepsilon_{2R}] \log_2 v_0$. The total calculating expenditures for realization of multistage structure include expenditures for realization of the input comb filter TsGF₀ and the expenditures for realization of R-stage connection of filters TsGF_i, $i = \overline{1, R}$

$$V_R = \alpha \beta L_1[\varepsilon_{1R}/(R+1), \varepsilon_{2R}] / v_0 + 4L_2[\varepsilon_{1R}/(R+1), \varepsilon_{2R}] \log_2 v_0. \quad (9)$$

Having substituted (8) into expression (9) and having assumed that $L_1[\varepsilon_{1R}/(R+1), \varepsilon_{2R}] = L_2[\varepsilon_{1R}/(R+1), \varepsilon_{2R}] = L[\varepsilon_{1R}/(R+1), \varepsilon_{2R}]$, we find

$$V_R = [8\alpha + 4 \log_2(\beta/8)] L[\varepsilon_{1R}/(R+1), \varepsilon_{2R}].$$

The effectiveness of multistage realization in the sense adopted earlier, provided that $L(\varepsilon_{1R}/(R+1), \varepsilon_{2R}) \approx L(\varepsilon_{1R}, \varepsilon_{2R})$, lies in the range $E_R = V/V_R = \alpha \beta / [8\alpha + 4 \log_2(\beta/8)]$.

The results of calculating the required number of multiplication operations for realization of narrowband finite pulse characteristic filters according to non-stage V, two-stage V₁ and multistage V_R structures are presented in Table 1 as an illustration of the effectiveness of the proposed method. It is assumed that a value of $L(\varepsilon_{1d}, \varepsilon_{2d}) = 4$ can be used to provide the required frequency selectivity of the filter to be designed [6].

CONCLUSIONS. 1. The proposed method of designing digital finite pulse characteristic filters permits a significant reduction of the total volume of calculating expenditures for realization of a narrowband filter (the efficiency index reaches tens and hundreds of units for $\alpha \geq 1$ and $\beta \geq 1,000$) with respect to non-stage realization of direct convolution.

2. The order of the elementary filters to be used--comb filters with pulse characteristics of the same type--can be reduced significantly (hundreds of times) upon conversion to a multistage structure of a narrowband finite pulse characteristic filter. A decrease of the order of elementary digital comb

Table 1

β	64						256					
α	0,5	1	2	4	8	16	0,5	1	2	4	8	16
V	128	256	512	1024	2048	4096	512	1024	2048	4096	8192	16384
V_1	56	79	111	160	256	448	111	157	222	314	443	640
\mathcal{J}_1	2,3	3,2	4,6	6,4	8	9,1	4,6	6,5	9,2	13	18,5	25,6
V_R	64	80	112	176	304	560	96	112	144	208	336	592
\mathcal{J}_R	2	3,2	4,6	5,8	6,7	7,3	5,3	9,1	14,2	19,7	24,4	27,7

β	1024						4096					
α	0,5	1	2	4	8	16	0,5	1	2	4	8	16
V	2048	4096	8192	16384	32768	65536	8192	16384	32768	65536	131072	262144
V_1	222	314	444	627	887	1254	444	628	888	1254	1774	2508
\mathcal{J}_1	9,2	13	18,4	26,1	36,9	52,3	18,5	26,1	36,9	52,3	73,9	105
V_R	128	144	176	240	368	624	160	176	208	272	400	636
\mathcal{J}_R	16	28,4	46,5	68,3	89	105	51,2	93,1	158	241	328	413

filters (measured by the number of readings of the pulse characteristic distinct from zero) in turn permits one to reduce the natural noise level at the output of a multistage connection of elementary filters, to reduce the ROM capacity for storage of readings of the pulse characteristic of filters and to simplify the procedure of calculating a narrowband finite pulse characteristic filter based on known methods of optimization in the frequency domain.

3. A disadvantage of multistage realization of a finite pulse characteristic filter is an increase of the nonuniformity of its amplitude-frequency characteristic in the bandpass in proportion to the number of stages. Therefore, the optimum two-stage structure can be used in those cases when there is the necessary margin in speed.

4. The proposed method does not lead to the appearance of specific sources of processing error, related to decimation and interpolation of digital signals, with respect to known methods of design of narrowband finite pulse characteristic filters that utilize the idea of secondary quantification and subsequent interpolation of the readouts of the output signal.

5. Investigation and development of methods of designing a set of digital bandpass filters based on multistage and pyramid structures of elementary digital comb filters are of interest in further development of the proposed approach to design of digital filters with finite memory.

BIBLIOGRAPHY

1. Rabiner, L. and B. Gold, "Teoriya i primeneniye tsifrovoy obrabotki signalof" [The Theory and Application of Digital Signal Processing], translated from English, edited by Yu. N. Aleksandrov, Moscow, Izdatel'stvo "Mir", 1978.

2. "Primeneniye tsifrovoy obrabotki signalov" [The Application of Digital Signal Processing], edited by E. Oppenheim, translated from English, edited by A. M. Ryazantsev, Moscow, Izdatel'stvo "Mir", 1980.
3. Gold, B. and C. Raider, "Tsifrovaya obrabotka signalov" [Digital Signal Processing], translated from English, edited by A. M. Trakhtman, Moscow, Izdatel'stvo "Sovetskoye radio", 1973.
4. Vityazev, V. V. and A. I. Stepashkin, "Comparison of Different Realization of Non-Recursive Narrowband Digital Filters," RADIOTEKHNIKA, Vol 33, No 10, 1978.
5. Vityazev, V. V. and A. I. Stepashkin, "Method of Designing Digital Narrowband Filters with Truncated Pulse Characteristic," IZVESTIYA VUZOV MV i SSO SSSR. PRIBOROSTROYENIYE, Vol 20, No 6, 1977.
6. Vityazev, V. V. and A. I. Stepashkin, "Designing the Structure of a Digital Narrowband Filter Using Secondary Quantification," IZVESTIYA VUZOV MV i SSO SSSR. PRIBOROSTROYENIYE, Vol 23, No 6, 1980.
7. Croszier, R. E. and L. R. Rabiner, "Interpolation and Decimation of Digital Signals. Methodical Survey," TIIEP, Vol 69, No 3, 1981.
8. Stepashkin, A. I. and V. V. Vityazev, "Design of Digital Bandpass Filters," RADIOTEKHNIKA, Vol 33, No 3, 1978.

COPYRIGHT: "Izvestiya vysshikh uchebnykh zavedeniy MV i SSO SSSR. Radioelektronika", 1983.

6521

CSO: 8144/0276-A

UDC 621.372.852.1

MAXIMALLY FLAT APPROXIMATION OF ATTENUATION CHARACTERISTICS OF COUPLED-LINE FILTERS

Kiev IZVESTIYA VYSSHIKH UCHEBNYKH ZAVEDENIY: RADIOELEKTRONIKA in Russian Vol 26, No 8, Aug 83 (manuscript received 6 Jan 83) pp 31-34

TRIFONOV, I. I. and SALIVON, V. N.

[Abstract] Coupled-line filters are structurally configured so that each internal line is coupled only to the two adjacent ones; the filter is thus equivalent to a cascade circuit of coupled lines connected in pairs. The transmission matrix of the entire network is found as the product of the transmission matrices of its individual cascaded sections. It is most convenient to utilize wave transmission matrices to describe the parameters of such filters. This approach is employed as the basis for a numerical method of solving the problem of approximating filter attenuation so that the response is maximally flat within the passband and isoextremal in the stopband. The derived algorithm always leads to physically feasible transmission matrix functions. The elements of the filter section conductance matrix are found by means of expanding a special form of the input conductance of the loaded network in a continued fraction. Figures 1; references 4 (Russian).
[52-8225]

UDC 621.372.852.1

MINIATURE TWO-MODE FILTERS

Moscow ELEKTROSVYAZ' in Russian No 9, Sep 83 (manuscript received 2 Dec 82) pp 33-35

BERGER, M. N., KAPILEVICH, B. Yu. and ISHCHUK, A. A.

[Abstract] Significant miniaturization of band filters for such applications as digital radio relaying has been achieved by use of waveguide structures beyond cutoff with dielectric filler. Further miniaturization is

possible by use of two-mode resonators based on such structures. The resonator is a segment of a waveguide with square cross section and a dielectric insert placed at the center equidistant from both ends. The dimensions of this insert and the dielectric characteristics of its material ensure propagation through it. The insert can cover the center cross section completely or partially, but it must be symmetric with respect to the plane at a 45° angle to the polarization plane of the excited mode. This will ensure identical condition for excitation of two mutually orthogonal modes within the space of one resonator. As a mathematical model for performance analysis, the filter can be treated as a pair of waveguide-dielectric resonators connected in series. On this basis are calculated its reflection and transmission coefficients, also normalized resonance frequencies. The design is based on attaining maximum Q-factor, minimum insertion loss, and optimum frequency characteristic of the voltage standing-wave ratio. Figures 4; references 6 (Russian).
[61-2415]

UDC 621.372.54.037.372

METHOD OF DESIGNING DIGITAL BAND-PASS FILTERS WITH PULSE RESPONSE OF FINITE DURATION

Kiev IZVESTIYA VYSSHIKH UCHEBNIKH ZAVEDENIY: RADIOELEKTRONIKA in Russian
Vol 26, No 9, Sep 83 (manuscript received, after revision, 25 Oct 82)
pp 3-9

VITYAZEV, V. V., MURAV'YEV, S. I. and STEPASHKIN, A. I.

[Abstract] A design method is proposed for narrow-band-pass filters with finite pulse response duration, such filters being used for digital processing of signals such as linear frequency selection. It is based on the use of 2-stage or multistage combs rather than on conventional direct convolution or on secondary discretization (decimation) with subsequent interpolation of output readings. In the 2-stage case the design reduces essentially to synthesis of an equivalent low-pass filter with appropriate frequency selectivity. The number of multiplications per discretization period, which decreases with decreasing bandwidth of the main stage but increases with decreasing bandwidth of the smoothing stage, can be reduced by successive addition of stages. Such filters can be realized with components of one type having identical pulse response characteristics and with a significant reduction of the noise level. The inevitable attendant nonuniformity of amplitude-frequency characteristics can be avoided by optimizing a 2-stage design instead. This method is free of errors inherent in other methods. Figures 4; tables 1; references 8: 7 Russian, 1 Western (in Russian translation).
[58-2415]

GENERALIZATION OF DISCRETE FOURIER TRANSFORM FOR INTERPOLATION IN TIME DOMAIN

Kiev IZVESTIYA VYSSHIKH UCHEBNYKH ZAVEDENIY: RADIOELEKTRONIKA in Russian
Vol 26, No 9, 1983 (manuscript received 17 May 82 after revision) pp 67-69

[Article by V. A. Ponomarev and O. V. Ponomareva]

[Text] An artificial increase of the determination interval due to addition by zero readings is used frequently in digital signal processing problems. Specifically, addition is carried out in the frequency domain in interpolation of the time sequence [1, 2]. A large number of redundant calculations must be carried out when using the standard discrete Fourier transform (DPF), realized by using algorithms of the fast Fourier transform (BPF).

The problem of this paper is to construct an algorithm for fast calculation of the Fourier transform of discrete sequences, supplemented by zeros in the frequency domain. The traditional discrete Fourier transform in matrix format is given by the following relations:

$$\vec{S}_N = F_N \vec{X}_N, \vec{X} = F_N^* \vec{S}_N, \quad (1)$$

where $\vec{X}_N = [x(0), x(1), \dots, x(N-1)]^T$ is the representation of the discrete signal in the form of the vector of a N-dimensional linear space and

$$\vec{S}_N = [s(0), s(1), \dots, s(N-1)]^T$$

is the vector of expansion coefficients X_N by a system of discrete exponential functions (DEF).

When solving the interpolation problem, addition by zero readings is carried out in the frequency domain in the following form:

$$\vec{S}_{Nr} = [s(0), \dots, s(N/2-1), \underbrace{0, \dots, 0}_{N(r-1)}, s(N/2), \dots, s(N-1)]^T. \quad (2)$$

Calculation of the discrete function \vec{X}_{Nr} to be interpolated, according to formula (1) leads to truncation of the columns of matrix F_{Nr}^* , i.e., to conversion of it from a quadratic to a rectangular matrix $D_{Nr \times N}^*$.

	0	N/2-1	N/2+N(r-1)	Nr-1	k
0	1				
1		$\frac{N-1}{r}$	$\frac{N+N(r-1)}{r}$	$\frac{N-1+N(r-1)}{r}$	
\dots					
Nr-1		$\frac{(N-1)(Nr-1)}{r}$	$\frac{N+N(r-1)}{r}(Nr-1)$	$\frac{N-1+N(r-1)}{r}(Nr-1)$	

	0	N/2-1	N/2	N-1	k
0	1	$W_N^{-\theta(N/2-1)}$	$C_0 W_N^{\theta N/2}$	$C_0 W_N^{-\theta(N-1)}$	
1		$W_N^{-(1+\theta)(N/2-1)}$	$C_0 W_N^{-(1+\theta)N/2}$	$C_0 W_N^{-(1+\theta)(N-1)}$	
\dots					
(N-1)		$W_N^{-(N-1+\theta)(N/2-1)}$	$C_0 W_N^{-(N-1+\theta)N/2}$	$C_0 W_N^{-(N-1+\theta)(N-1)}$	

Having applied the operation of comparison with respect to r to the set of numbers of the lines of this matrix, we find r subsets of the residue classes modulo r. Using the derived partitioning, matrix $D_{Nr \times N}^*$ can be represented in the form of r square matrices $H_{N, \theta}^*$, the dimensionality of each of which is equal to N; $\theta = 0, 1/r, \dots, (r-1)/r$; $C_0 = W_N^{N\theta}$, while the numbers of the lines of which are residue classes modulo r.

Using the concept of complex conjugate parametric discrete exponential functions (DEF-P)

$$\text{def}_p(n, k, \theta) = W_N^{-(n+\theta)k}, \quad W_N = \exp\left(-j \frac{2\pi}{N}\right), \quad 0 \leq \theta < 1,$$

matrix $H_{N, \theta}^*$ can be represented in the form of the product

$$H_{N, \theta}^* = \bar{F}_{N, \theta} \begin{bmatrix} I & 0 \\ 0 & C_0 I \end{bmatrix} = \bar{F}_{N, \theta} R,$$

where $\bar{F}_{N, \theta}$ is the matrix of complex conjugate parametric discrete exponential functions and I is a unit matrix of dimension N. Then the sequence to be interpolated can be found as

$$\bar{X}_{N, \theta} = \bar{F}_{N, \theta} R \bar{S}_N \quad (3)$$

Let us consider generalization of the algorithm of a fast Fourier transform for calculation of interpolation of the time sequence $x(n)$, $n = 0, N-1$, $N = 2^p$, $p = 0, 1, \dots$. When constructing the algorithms of fast Fourier transforms for calculation of the standard discrete Fourier transform, two methods of constructing fast algorithms are possible: time and frequency cutting, which is explained by the properties of the matrix of the discrete exponential function \bar{F}_N . The structure of matrix $\bar{F}_{N, \theta}$ permits one to carry out factorization only by the time cutting method, by using two of which it is easy to establish that this leads to reformation of the table of rotary factors of the standard fast Fourier transform according to the following relations upon interpretation of the fast parametric Fourier transform in the form of a graph:

$$W_{N, p}^n = W_{N, p} W_N^{-N\theta/2^p}, \quad p = 1, \dots, l, \quad (4)$$

where p is the number of the layer of the fast Fourier transform, $W_{N,p}^p$ is the rotating factor of the p -th layer of the inverse fast Fourier transform and $W_{N,p}$ is the rotating reformed factors of the p -th layer of the fast parametric Fourier transform.

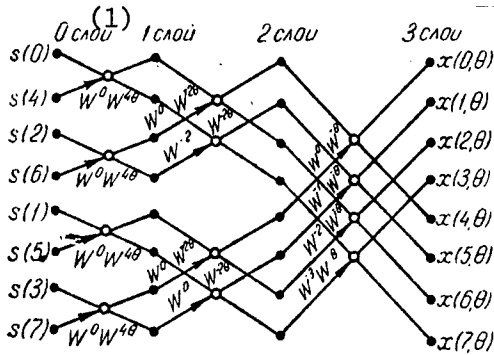

Figure 1

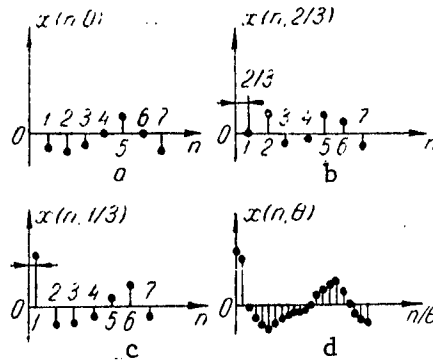

Figure 2

Key:

1. Layer

To find the sequence $\vec{X}_{N,\theta}$ to be interpolated by the method of the fast parametric Fourier transform, according to formula (3), one must first find the matrix product $R\vec{S}_N$, which requires supplementary calculations. Analysis of the structure of matrices $F_{N,\theta}$ and R shows that matrix $H_{N,\theta}^*$ can also be factorized. This leads to modification of the graph of the fast parametric Fourier transform, the rotating factors of which on the first layer are equal to

$$W_{N,1}^n = W_{N,1} W_N^{+N0/2}$$

The modified directional graph of the algorithm of the fast parametric Fourier transform for calculation of an eight-point sequence is presented in Figure 1. The example presented in Figure 2 illustrates the work of the proposed algorithm.

For interpolation in the time domain, the algorithm that uses addition by zero readings includes the following operations:

1. Calculation of the spectrum by the method of the fast Fourier transform ($N/2 \log_2 N$ operations).
2. Addition of the zero readings in the middle of the derived spectrum (r -fold dilitation of the signal).
3. Calculation of the inverse fast Fourier transform of the spectrum, added by zeros ($Nr/2 \log_2 Nr$ operations).

Thus, the computing expenditures comprise $N/2(\log_2 N + r \log_2 N + r \log_2 r)$ operations. We note that the values of the input function are also calculated repeatedly in this case. The memory expenditures are Nr complex cells.

For interpolation using a modified fast parametric Fourier transform, one must perform the following steps:

1. Calculation of the spectrum by the method of fast Fourier transform ($N/2\log_2 N$ operations).
2. Calculation of $r - 1$ -fold modified fast parametric Fourier transform to find the function to be interpolated at intermediate points (the number of operations is $(r - 1)N/2\log_2 N$).

The total number of operations is $rN/2\log_2 N$ and the memory required for the calculations comprises N cells. Thus, the economy of calculating expenditures is determined by the expression

$$K = \frac{N \log_2 N + Nr \log_2 N + Nr \log_2 r}{Nr \log_2 N} = 1 + \frac{1}{r} + \frac{\log_2 r}{\log_2 N}.$$

It should be noted in conclusion that the use of parametric discrete exponential functions permits one to find the sequence $X_{n,\theta}$ to be interpolated at any values of parameter θ from the interval $[0, 1)$ and not only at $\theta = i/r$, $i = 1, (r - 1)$, where r is an integer.

BIBLIOGRAPHY

1. Rabiner, L. and B. Gold, "Teoriya i primeneniye tsifrovoy obrabotki signalov" [The Theory and Application of Digital Signal Processing], Moscow, Izdatel'stvo "Mir", 1978, 848 pages.
2. Gold, B. and C. Raider, "Tsifrovaya obrabotka signalov" [Digital Signal Processing], Moscow, Izdatel'stvo "Sovetskoye radio", 1973, 367 pages.

COPYRIGHT: "Izvestiya vysshikh uchebnykh zavedeniy MV i SSO SSSR. Radioelektronika", 1983.

6521

CSO: 8144/0276-B

UDC 621.391.2:681.142.4

OPTIMUM PREDISTORTION OF DIGITAL SIGNALS FOR TRANSMISSION OVER PARALLEL CHANNELS

Kiev IZVESTIYA VYSSHIKH UCHEBNIKH ZAVEDENIY: RADIOELEKTRONIKA in Russian Vol 26, No 9, Sep 83 (manuscript received 7 Sep 82) pp 18-23

KRASNOV, L. M. and MARIGODOV, V. K.

[Abstract] Predistortion of signals is considered for high-speed digital data transmission over parallel linear channels where intersymbol interference limits the speed, with fluctuation noise assumed to be negligible. All channels are assumed to be identical, a random sequence of rectangular signals appearing at the input of each. A filter is inserted into each channel, which transforms an inevitably "blurred" signal into one of the necessary sharpness. Synthesis of the predistorting structure is facilitated by representing the predistorted signal in discrete form. Analysis of the dynamics of signal transmission and calculations according to the method of the state space yield a signal consisting of two parts, the first part appearing at the channel output and the second part being cancelled. For determining the optimum predistortion, a typical channel comprising a transmission line with distributed parameters and capacitive load is modeled with a second-order low-pass filter. An optimum predistorted signal, producing a finite response of the same duration and appropriate amplitude, is shown to be attainable by insertion of a transversal filter. Figures 4; tables 1; references 25: 12 Russian, 13 Western (6 in Russian translation).

[58-2415]

ESTIMATE OF SIGNAL-TO-INTERFERENCE ENERGY RATIO IN DISCRETE-DATA TRANSMISSION

Kiev IZVESTIYA VYSSHIKH UCHEBNIKH ZAVEDENIY; RADIOELEKTRONIKA in Russian
Vol 26, No 9, Sep 83 (manuscript received, after revision, 27 Sep 82) pp 23-29

ARZUMANYAN, Yu. V. and ZAKHAROV, A. A.

[Abstract] The energy characteristics of discrete-data transmission channels with fluctuations are analyzed, specifically the signal-to-interference ratio. Its maximum-likelihood estimate is approached for a linearly stochastic channel transmitting isoenergetic orthogonal binary signals. Use is made of the interrelation between the conditional probability density of envelope readings at the matched output filters and the probability of detection error. First a channel is considered where the transmission coefficient remains constant throughout the entire estimation time interval. In this case the mean-harmonic estimate is found to be sufficiently close to the maximum-likelihood estimate and the latter to be a biased one. A channel with a Rayleigh fadeout distribution is then considered. In this case solution of the corresponding equation is shown, by mathematical induction, to be equivalent to finding the positive root of a polynomial which, according to the Descartes rule, has only one positive root. Here the maximum-likelihood estimate is also biased, but the bias can be reduced. In both cases the estimates have a dispersion. When no a priori information about the signal is given, then the same algorithms of estimation will remain applicable after demanipulation which involves individual modeling of each statistic, although both the bias and the dispersion will increase as a result. Figures 2; references 8 (Russian).
[58-2415]

EFFICIENCY OF DISCRIMINATION IN SOME INVARIANT SIGNAL TRANSFORMATIONS

Kiev IZVESTIYA VYSSHIKH UCHEBNIKH ZAVEDENIY; RADIOELEKTRONIKA in Russian
Vol 26, No 9, Sep 83 (manuscript received, after completion, 22 Nov 82)
pp 58-60

ATAYANTS, B. A. and RUMYANTSEV, V. P.

[Abstract] The dependence of the discrimination efficiency on the form of invariant signal transformation is evaluated in terms of the probability of identification error. Discrimination of two classes of signals is considered, after they have been transformed invariantly with respect to amplitude changes and after a delay equal to three instrument readings (decision based on first reading $\xi_j^{(1)}$): $\xi_j^{(2)} = \vartheta(A_i, A_{i+1}) = (A_{i+1} - A_i) / (A_{i+1} + A_i)$;

$\xi_j^{(3)} = \delta(A_i, A_{i+1}) = A_i/A_{i+1}$. The error of discrimination is compared with the estimate of the error probability, with functions of two nonstationary characteristics $C_1(\alpha_1)$ and $C_2(\alpha_2)$ as parameters. These characteristics, expressed through dispersions of adjacent readings are $\alpha_1 = (\sigma_{i+1}^2 - \sigma_i^2) / (\sigma_{i+1}^2 + \sigma_i^2)$ and $\alpha_2 = (\sigma_{i+2}^2 - \sigma_{i+1}^2) / (\sigma_{i+2}^2 + \sigma_{i+1}^2)$; $|\alpha_1|, |\alpha_2| \leq 1$. Results are shown for class I and class II of signals with $C_{1II}(\alpha_1) = 1$ and $C_{2I}(\alpha_2) = C_{2II}(\alpha_2) = 1$, $C_{1I}(\alpha_1)$ varied and the discrimination error as function of this variable. Figures 2; references 2 (Russian). [58-2415]

UDC 621.391.81

GENERALIZATION OF DISCRETE FOURIER TRANSFORMATION FOR INTERPOLATION IN TIME DOMAIN

Kiev IZVESTIYA VYSSHIKH UCHEBNYKH ZAVEDENIY: RADIOELEKTRONIKA in Russian Vol 26, No 9, Sep 83 (manuscript received 17 May 82) pp 67-69

PONOMAREV, V. A. and PONOMAREVA, O. V.

[Abstract] A fast algorithm of conventional Fourier transformation of discrete sequences in the time domain with complementing zeros in the frequency domain is constructed, the purpose of such a complementation being to lengthen artificially the interval of determination and thus facilitate interpolation. The discrete signal is represented as a vector of an N-dimensional linear space, namely that of coefficients X_N of an expansion in a system of discrete exponential functions. Upon introduction of complex-conjugate discrete exponential functions, the algorithm becomes a generalization of the algorithm of fast Fourier transformation. Thinning out can proceed either in the time domain or in the frequency domain. Figures 2; references 2 (Western) (both in Russian translation). [58-2415]

OPTIMALITY CRITERION FOR HIGH-FREQUENCY CHANNEL IN RECEIVERS OF DISCRETE RADIO SIGNALS

Kiev IZVESTIYA VYSSHIKH UCHEBNYKH ZAVEDENIY: RADIOELEKTRONIKA in Russian
Vol 26, No 9, Sep 83 (manuscript received, after revision, 20 Jul 82) pp 71-72

PALSHKOV, V. V.

[Abstract] An optimum receiver of discrete radio signals is defined as one without internal noise and nonlinear signal-interference interaction in its high-frequency channel. The interference level in such a channel determines the probability of detection error, and the larger than unity ratio of real-to-ideal error probability can be regarded as the optimality criterion for a real receiver in terms of interference immunity. This ratio is an intricate function of receiver structure and performance indicators such as the forms of its amplitude-frequency and phase-frequency characteristics and the resolver threshold level. This relation becomes simpler in the case of low interference level and small detection error probability. Calculations based on characteristics of high-quality modern receivers indicate that nearly optimum reception is attainable through minimization of the ratio of real-to-ideal error probability. The feasibility has been demonstrated on a superheterodyne receiver. References 4 (Russian).
[58-2415]

CONTROLLABLE COMPANDING IN LOW-FREQUENCY F-M RADIO COMMUNICATION SYSTEMS

Kiev IZVESTIYA VYSSHIKH UCHEBNYKH ZAVEDENIY: RADIOELEKTRONIKA in Russian
Vol 26, No 9, Sep 83 (manuscript received 8 Sep 82) pp 73-75

GOLOVIN, E. S.

[Abstract] Decreasing the separation between adjacent channels is an effective way to better utilize the radio frequency spectrum for communication systems operating in the metric or decimetric wave bands. As the frequency separation is narrowed down to ± 2.5 kHz in an FM telephone system, for instance, the loss in interference immunity becomes so appreciable that it becomes necessary to either increase the transmitter power or to reduce the service area. Here a remedy is proposed which restores the interference immunity by companding of the telephone signals. In one version of such an arrangement the telephone signal is resolved into two components, one going to the information channel and one going to the control channel. In the latter the signal envelope, i.e., signal amplitude variation is duplicated with the aid of an amplitude detector and contained within the 0-20 Hz range of the frequency spectrum. The pilot signal thus generated controls the compressor

in the information channel so that at the latter's output a signal appears of constant amplitude contained within the 300-3400 Hz range of the frequency spectrum and carrying information about the instantaneous frequency of the speech signal. After being amplified separately, the information signal and the pilot signal are linearly superimposed for subsequent modulation at the transmitter carrier frequency. In the receiver the incoming signal passes through a frequency detector and then through a filter which extracts the pilot signal, the latter then being sent to the expander for recovery of the speech signal amplitude fluctuations. The expander gain characteristic should be the inverse of the compressor gain characteristic, and noise suppression in the expander will further increase the signal-to-interference ratio in the low-frequency channel. Figures 2; references 2 (Russian).
[58-2415]

UDC 621.391.244:681.327.8

GRADIENTAL ADAPTIVE CORRECTOR WITH OPTIMUM TUNING STEP

Kiev IZVESTIYA VYSSHIKH UCHEBNYKH ZAVEDENIY; RADIOELEKTRONIKA in Russian
Vol 26, No 9, Sep 83 (manuscript received, after revision, 28 Mar 83)
pp 85-87

MIKHAL'CHAN, V. S.

[Abstract] The paper considers gradiental harmonic band corrector with adaptive tuning through a δ -function sequence. An iterative algorithm of adaptive tuning is constructed according to the variational method, with use of the a posteriori information which each iteration yields and with minimization of the mean-square deviation. A two-dimensional corrector input signal and the corrector output reading are each represented as projections of their respective cophasal and quadrature components. The deviations of these two components of the corrector output reading from those of the target reference reading are related to the deviations of these two components of the corrector input signal from those of the target reference reading and, on this basis, the adjustable corrector parameters on any iteration are determined from those on the preceding iteration by the method of steepest descent. The partial derivatives of the deviations, which appear in the expressions for these parameters, are evaluated by differentiation and inserted into the original expressions for the components of a corrector output reading. The convergence ratio of tuning step is then optimized for maximally attainable minimum mean-square deviation. Figures 2; references 3 (Russian).
[58-2415]

NONLINEAR FILTRATION OF CLUTTER

Kiev IZVESTIYA VYSSHIKH UCHEBNIKH ZAVEDENIY: RADIOELEKTRONIKA in Russian
Vol 26, No 9, Sep 83 (manuscript received, after revision, 14 Feb 83)
pp 87-89

SABIROV, Zh. A.

[Abstract] The problem of nonlinear filtration according to minimum mean-square error as a criterion is solved for a signal $s(b,t)$, appearing in an additive mixture with clutter $v(c,t)$ and white noise $n(t)$. For synthesis of the nonlinear optimum filter, its characterizing continuous operator $F[u(\vec{\alpha},t)]$ is expanded into a product of sums and a product. Minimization of the corresponding functional $\langle s(\vec{b},t) - F[u(\vec{\alpha},t)] \rangle^2$ reduces the problem to a system of equations which yields the filter parameters and mean-square error. For illustration, the procedure is applied to filtration of a narrow-band signal $b_1(t)\cos\omega_1 t$ appearing with a narrow-band non-Gaussian clutter $c_1(t)\cos(\omega_2 t + c_2(t))$ and white noise. A 2-channel signal splitting multipole network with output signals proportional respectively to $b_1\cos\omega_1 t + c_1\cos(\omega_2 t + c_2)$ and $b_1\omega_1\cos\omega_1 t + c_1\omega_2\cos(\omega_2 t + c_2)$ is adequate in the case of weak white noise. The energy advantage of the nonlinear optimum filter over the linear one increases with increasing power of the non-Gaussian clutter, but vanishes in the absence of white noise. Figures 2; references 5 (Russian).

[58-2415]

SYNTHESIS OF SYSTEM WITH NONIDEAL COMPONENTS FOR OPTIMAL PROCESSING OF RADIO SIGNAL

Kiev IZVESTIYA VYSSHIKH UCHEBNIKH ZAVEDENIY: RADIOELEKTRONIKA in Russian
Vol 26, No 9, Sep 83 (manuscript received 19 Oct 82) pp 91-93

TATARNIKOV, V. G.

[Abstract] Synthesis of a system with nonideal components for processing radio signals is considered, with nonideality of the characteristics being successively accounted for in the Kalman-Bussys equations. The optimum structure attainable with components of a given less than ideal quality is found on this basis. The procedure is demonstrated on processing an additive mixture of a random signal with uniform spectral density within some frequency band and a quasi-deterministic narrow-band interference with random parameters. The system which consists of two summaters, six multipliers, and two integrators becomes an open one when the output voltage of the two integrators drifts in time. Replacement of ideal integrators with real ones is found to be equivalent to addition of another

noise consisting of two independent Wiener processes. The equations are modified accordingly, and the optimum processing algorithm obtained on this basis. The structure of the system remains unchanged, but the transmission coefficient of the two multipliers before the integrators does not drop to zero so that the system remains closed during a transient. Figures 1; references 3: 2 Russian, 1 Western (in Russian translation). [58-2415]

UDC 621.395.74

AUTOMATION OF DESIGN OF LARGE TELEPHONE NETWORKS (REVIEW)

Moscow ELEKTROSVYAZ' in Russian No 9, Sep 83
(manuscript received 23 Dec 80) pp 1-5

SERGEYEVA, O. F.

[Abstract] Design automation for planning large telephone networks with preferably multilevel distributed structure, including bypass routes and decentralization as well as traffic control, is based on a mathematical model of their principal components: terminal points, switching points, concentrators and connection lines. The most expedient model is an oriented or nonoriented graph with corresponding vertices and edges. In the case of networks with channel switching and overt losses there are constraints imposed on either the service quality or the queuing time. A design automation system consists of four functional modules. One module is for layout and optimization of the network, most often with a radial-nodal topology. Another module is for optimizing the distribution of channels and message flux. The third module is for selecting the capacity of network branches, usually on the basis of cost implicitly defined by maximum and minimum losses with the network topology known and either the call matrix and the static flux distribution or the call matrix and the allowable losses given. The fourth module is for evaluating the traffic capacity, with the network performance (service quality) parameters in the case of channel switching calculated by the iterative method of dynamic programming. Figures 1; references 30: 16 Russian, 14 Western (5 in Russian translation). [61-2415]

DIALING SYSTEMS IN INTERNATIONAL TELEPHONE NETWORK (REVIEW)

Moscow ELEKTROSVYAZ' in Russian No 9, Sep 83
(manuscript received 5 Nov 81) pp 5-9

ZHARKOV, M. A.

[Abstract] Development of telephone dialing systems is reviewed, from the early stages during the nineteen thirties and forties till the latest Unified Automatic Communication System introduced in the nineteen seventies. Here two-frequency transmission of line signals has been replaced with single-frequency transmission and use of self-checking codes for higher speed and better control. Recently it has also been found necessary to introduce a common-channel dialing system for more efficient operation, as ten-step and coordinate systems in decentralized automatic exchanges are being gradually replaced by electronic and quasi-electronic systems in centralized ones. The advantages of common-channel dialing become evident upon analysis of its performance characteristics. The main indicator of service quality here is the probability of a longer than 0.3 s delay of the "answer" message, which according to ITTCC recommendations should be 10^{-4} . This probability is calculated from the time distribution of delay, the latter being the sum of service interval, queuing time, and transmission time. A Laplace-Stiltjes transformation and subsequent inverse transformation yield the relations which describe how the capacity of an array of conversation channels served by one common-channel dialing system depends on the number of signal processing points, on the error factor, and on the presence (or absence) of prioritization, for given size and reliability level of the common channel. Typical results, assuming that all segments of the common channel are identical, are shown here for signal transmission rates of 4.8 and 64 kbit/s, respectively. From the complete set of graphs for all combinations of parameters one can determine the traffic capacity of the common-channel dialing system. Figures 8; references 7: 4 Russian, 3 Western.
[61-2415]

UDC 621.391:338.94

ESTIMATING OPTIMUM TECHNICAL AND ECONOMIC INDICATORS OF DATA TRANSMISSION SYSTEMS

Moscow ELEKTROSVYAZ' in Russian No 9, Sep 83
(manuscript received 17 Feb 81) pp 45-48

SHAREYKO, L. A.

[Abstract] Selection of the technically and economically optimum design variant for planning or simulating a data transmission system necessitates determination of the optimum requirements for the various system components.

For solving this difficult problem, one must establish the pertinent relations between their parameters and how their cost depends on them. This is done by defining the appropriate criterion for cost effectiveness and constructing a mathematical model of the transmission channel. Subsequent calculations will yield the optimum variant accordingly, as is shown in the typical case of a Poisson distribution of the interference and exponential distributions of both the message lengths and the failure clearance time. It has been assumed in this illustrative example that the principle of noninterdependence applies to all nodal points of the system. Calculations cover the reasonable cost of ensuring reliability of the system components. References 10: 8 Russian, 2 Western (both in Russian translation).
[61-2415]

UDC 621.395.74.037.37

USE OF DIGITAL EQUIPMENT IN USSR UNIFIED AUTOMATED COMMUNICATIONS NETWORK

Moscow ELEKTROSVYAZ' in Russian No 10, Oct 83
(manuscript received 14 Jun 83) pp 11-13

KORDONSKIY, E. V., MAMONOV, Ye. S., MEKKEL', A. M., MEL'NIKOV, P. V. and SIL'VINSKAYA, K. A.

[Abstract] Although digital communications hardware has significant advantages over its analog counterparts (better qualitative indicators, simpler to produce, build and operate and can be used to expand existing analog network), it is impossible to place such equipment in service everywhere at once. The creation of the digital net must start with individual sections of the primary digital system, concentrating the digital transmission links in them and later installing digital switching equipment. The development of the major digital communications equipment for the USSR YeASS (Unified Automated Communications Network) is completed or now being completed. Some time is still required for industry to place this equipment in series production. The transition period from the analog to the digital system will be marked by the following: Digital systems will initially be used as conventional analog systems; the type of analog-digital conversion for generating the voice frequency channels in digital systems must be finally decided; the use of Pulse-Code modulation with eight-bit coding using A-87,6 companding (MKKTT [Informational Telegraph and Telephone Consultive Committee] Recommendation G.711) is recommended; a main digital channel is to have a capacity of 64 Kbit/s; the capacities of the primary, secondary, ternary and quaternary digital channels are 2,048, 8,448, 34,368 and 139,264 Kbit/s, respectively. This secondary through quaternary time group generation equipment is universal, because its group channels can operate in synchronous, asynchronous and plesiochronous modes. The design of the digital transmission equipment allows for splitting out standard digital channels using conventional time group generation equipment installed at attended repeaters. The channel generation equipment is designed so that 30 voice frequency channels, 31 primary digital channels or any combination

of them can be produced in a main digital trunk having a capacity of 2,048 Kbit/sec. The operational efficiency of the digital transmission system in the existing network can be significantly enhanced if the digital channels and trunks form a closed digital primary network section. The through-working transits of the analog channels and trunks can be replaced by digital channel and trunk transits. Regional digital networks will be joined together by digital trunks using the IKM-480x2, IKM-1920 and IKM-1920x2 digital trunk transmission systems to create the primary digital network. The creation of a common synchronization system is also planned for the primary and secondary networks, which will be tied into the State Standard Time and Frequency Service. References 3: 2 Russian, 1 Western. [50-8225]

RECONSTITUTION OF DIVERSE SHEATHS FOR TELEPHONE CABLES WITHOUT INTERMEDIATE WRAPPER

Moscow VESTNIK SVYAZI in Russian No 10, Oct 83 pp 31-32

BELENKO, A. K., section chief, Special Office of Communication Engineering and Technology, USSR Ministry of Communication

[Abstract] According to technical specifications TU-45-77, cables with sheaths of different materials are spliced together with use of intermediate wrappers: MPK-PS for splicing polyethylene and lead sheaths, MPK-VS for splicing polyvinyl chloride and lead sheaths, MPK-PV for splicing polyethylene and polyvinyl chloride sheaths. Size differences and hermetization requirements make this process very laborious and uneconomical, the manufacture of these wrappers being itself a rather intricate process. Upon introduction of cables with thermosetting sheath tubes into urban telephone networks, the possibility arises of eliminating the wrapper from the splicing process. This is demonstrated on two variants of splices, one with a polyethylene sleeve and one with a lead sleeve, after hermetization of both ends to be joined by beading. The process can also be intricate and would require special tooling. A simple version has been investigated and experimentally tried at the Special Office of Communication Engineering and Technology. It involves using a lead sleeve, a lengthwise slit lead bushing and a thermosetting tube with Savilen lining. Appropriate pretreatment of the cable ends and splice components before following the recommended splicing procedure should save 4.6 rubles per splice and 23,000 rubles per annum in cable installation costs. Figures 2. [60-2415]

DEVELOPMENTAL TRENDS IN RADIO RECEIVER DESIGN

Moscow ELEKTROSVYAZ' in Russian No 10, Oct 83
(manuscript received 26 Apr 82) pp 33-36

CHISTYAKOV, N. I.

[Abstract] A historical review of the development of shortwave receiver design is followed by an enumeration of the characteristics of the state of the art in shortwave reception equipment: 1) The problem of band coverage, for example in marine receivers from 10 KHz to 30 MHz, has been resolved by the use of infradyne circuits with an IF of 40 to 80 MHz and a broadband pre-selector; such designs also make it possible to base the local oscillator on a phase-locked loop; 2) Suppression of spurious frequencies is improved by placing them outside the working band through the use of a high first IF; 3) Enhanced linearity of the broadband RF amplifier and converter has extended the dynamic range of receivers, and eliminated the need for a narrow band preselector with the use of simple suboctave filters and low pass filters at the input; 4) The use of a decade frequency synthesizer based on a variable divisor frequency divider, highly stable master crystal oscillators, electronic varactor tuning of the local oscillator and Phase-locked loops provide for precise tuning to the requisite frequency, which is also improved by digital tuning and displays. A major aspect of present design work is the application of microprocessors to automatic tuning, programmed frequency setting and the performance of a variety of diagnostic functions in the receiver. Microprocessors will provide for comprehensive adaptation of receivers to complex reception conditions, further development of signal restoration equipment, etc. Extensive research is now underway in the development of piezoelectric, active and digital filters which can be used in IC's and CCD circuits and some other new components which will certainly lead to considerable structural and circuit design changes in receiving equipment. References 16 (Russian).

[50-8225]

UDC 621.315.212

RECONSTRUCTION OF EXISTING COMMUNICATIONS TRUNK LINES: INTRODUCTION

Moscow ELEKTROSVYAZ' in Russian No 10, Oct 83 p 43

[Abstract] The capital investments routed to the reconstruction and retrofitting of existing facilities are paid back an average of three times faster than in the case of new construction of similar capacities and the work force requirements are also curtailed. Reconstruction of existing communications systems is of great importance for the successful creation of the USSR Unified Automated Communications Network. The plans for the expansion of the primary trunk network in the 11th Five-Year Plan call for

gaining up to 80% of the increase in channel-kilometers through the retrofitting of existing cable and microwave relay links. Only reconstruction can provide the 80% increase in the length of long-distance channels. The scientific and engineering council of the USSR Ministry of Communications has adopted general resolutions to implement the planned reconstruction in the economic expansion of the trunk network. In order to more extensively familiarize the scientific and engineering community with the problems of reconstruction and exchange experience in this field, the editorial staff of ELEKTROSVYAZ' has prepared a topical selection of papers which deal with engineering solutions in use as well as areas requiring further study. The compilers of this selection are A. N. Tyulyayev and L. T. Kim.
[50-8225]

UDC 621.315.212

GENERAL PRINCIPLES OF CABLE TRANSMISSION LINE RECONSTRUCTION

Moscow ELEKTROSVYAZ' in Russian No 10, Oct 83
(manuscript received 6 Jul 83) pp 44-46

KIM, L. T.

[Abstract] In 1982, the Scientific and Technical Council of the USSR Ministry of Communications approved the following principles for the nation's transmission system: 1) Repeater sections 6, 3 and 1.5 km long are authorized for coaxial cable lines, making it possible to utilize fully the old unattended repeater containers with the transition to the next stage in increasing line capacity; 2) A standardized structural design for small unattended repeater containers, for direct burial in the ground, has been adopted as a standard for trunk systems; and 3) Standardized service communications and remote control subsystems for all transmission systems operating via a particular type of cable have been approved. The remote control equipment is modular with the capability of expanding remote control services in step with the changeover to higher capacity systems. The technical specifications of existing wire transmission systems to be used for the reconstruction of cable communications lines are summarized in tabular form, which lists the number of channels, repeater section lengths, maximum spacing between power supply stations, line spectrum and data transmission rate, method of line signal group generation, as well as the particular system used for retrofitting an existing cable. The introduction of such Pulse-code modulation digital transmission equipment as the IKM-120 is being held up only by production capability limitations. The implementation of the measures adopted by the Scientific and Technical Council of the USSR Ministry of communications will make it possible to utilize more completely the least expensive and most long-lived portion of the nation's primary network, line and cable facilities, by means of the sequential retrofitting of these lines. A number of technical and organizational problems must be solved for the successful reconstruction of each line and upcoming articles will deal with individual aspects of this complex task.
References 14 (Russian).

[50-8225]

COMMUNICATIONS TRUNK RETROFIT VARIANTS REPLACING K-1920 TRANSMISSION SYSTEMS BY K-3600

Moscow ELEKTROSVYAZ' in Russian No 10, Oct 83
(manuscript received 24 Jun 81) pp 47-49

LEBEDEV, A. V. and KIM, L. T.

[Abstract] The savings in capital investments when rebuilding a 1,000 km trunk, replacing the K-1920 vacuum tube equipment with the K-3600 solid state system, is on the order of 11 million rubles as compared to the construction of a new trunk, and in addition saves scarce copper and lead. The retrofitting work can be broken down into two stages: the preparatory work and main re-equipping work. This paper discusses the organization of the latter work, which involves three possible variants: 1) Shutting down all communications while the work is underway; 2) Intermittent shutdowns during the installation of unattended repeaters and 3) the use of a microwave relay link as a replacement line insert during the retrofitting. The impact of the different variants on service communications, remote control systems and the traffic itself is discussed. It is concluded that the effort to reduce the communications interruption time and to retain the maximum number of channels during the reconstruction period leads to an increase in the complexity and volume of the work and consequently to an increase in costs. Despite the reduction in communications downtimes, the overall reconstruction time rises considerably, and the quality and reliability of the channels are degraded during the work. The choice of the work organization variant must be based on a careful evaluation of all of the factors for each particular trunk. References 1 (Russian).

[50-8225]

INITIAL EXPERIENCE WITH REPLACEMENT OF TRANSMISSION SYSTEM ON COAXIAL CABLE

Moscow ELEKTROSVYAZ' in Russian No 10, Oct 83
(manuscript received 3 May 82) pp 49-51

CHERVINSKIY, R. V. and PRESS, A. M.

[Abstract] Production of K-3600 equipment has made it possible to begin large scale retrofitting of coaxial cable lines with this system. This paper describes the initial experience with the rebuilding of a cable trunk by TTsUMS-16 [Technical Center No. 16 for Communications Trunk Management] in 1981. The retrofitting involved replacing the K-1920 vacuum tube equipment on a trunk line about 700 km long, while retaining one K-1920 system in service. The operation was broken down into four stages: 1) The construction of the new K-3600 unattended repeater stations, 114 installed in

all; 2) The insertion of the K-3600 unattended repeaters in the cable trunk; 3) Assembling the equipment, transporting it as well as storage and testing; and 4) Alignment of the line sections between attended repeaters and retransmission stations. A microwave relay link was used as a temporary insert to replace the down system. Total reconstruction time was about 5 months, of which 65 days were required just for the splicing work. Figures 2.
[50-8225]

UDC 621.315.212

LESSONS IN COMMUNICATIONS CABLE LINE RECONSTRUCTION

Moscow ELEKTROSVYAZ' in Russian No 10, Oct 83
(manuscript received 30 May 83) pp 51-54

KHUTORYANSKIY, M. N.

[Abstract] The personnel of TTsUMS-8 [Technical Center No. 8 for Communications Trunk Management] together with subcontracting organizations of the USSR Ministry of Communications, the "Mezhgorsvyaz'stroy [All-Union State Trust for the Construction of Long-Distance Wire Communications Structure] and "Radiostroy" [Trust of the Ministry of Communications, USSR] as well as US-1 construction administration, completely reconstructed two balanced cable trunks, one coaxial trunk, individual sections of a second coaxial cable trunk and a number of microwave relay links. The number of attending personnel was reduced by 92 on the balanced cable lines as a result of reducing the number of attended repeaters and the changeover to 24-hour attendance at the remaining repeaters; the overall voice-frequency channel length increased by hundreds of thousands of channel-kilometers. The communications downtime for routine preventive maintenance was reduced by 6 hours per year for every 60-channel transmission system. The initial yield on capital was raised by 4.7 kopecks per ruble of fixed capital. The increase in coaxial cable capacity was more than two million km of telephone channels with the initial yield on capital boosted by 2.4 kopecks per ruble of fixed capital. The line capacity of microwave relay trunks increased by 2.5 million km of telephone channels and 1,700 km of TV channels figured on a simplex basis. The retrofitting of the cable and microwave links of the TTsUMS-8 began in the mid-1960's, while the pace became quite rapid beginning in 1977. After 1977, Gosbank credits were the source of financing and decentralized capital investments amounting to 13,958,000 rubles were used during these years. The paper deals in some detail with the procedure for retrofitting a balanced cable with K-60P equipment and a coaxial cable with VLT-1920 equipment. Some 1,315 km of microwave links were rebuilt with the "Voskhod" and "Voskhod-M" equipment by TTsUMS-8. A number of specific recommendations are made for the retrofitting and operation of such lines. References 2 (Russian).
[50-8225]

WORK TO ENHANCE RELIABILITY AND INCREASE CAPACITY OF PRIMARY NETWORK

Moscow ELEKTROSVYAZ' in Russian No 10, Oct 83
(manuscript received 15 Apr 83) pp 55-57

MENG, V. A.

[Abstract] Since 1970, the length of cable lines in the TTsUMS-3 [Technical Center No. 3 for Communications Trunk Management] increased by 1.25 times, the length of long distance telephone channels by 2.7 times and that of microwave links by 1.54 times. The TTsUMS-3 production volume was more than 28 million rubles in 1982 and more than doubled as compared to 1970, while the number of personnel increased 1.41 times with labor productivity also rising 1.41 times. The primary trunk network is now mostly being built as a radial system, using modern solid-state equipment. One cable trunk 482 km long is being retrofitted with K-1020S equipment for a single cable pair in the TTsUMS-3 service area. The details of this project are briefly discussed along with the improvement of existing equipment, such as the K-1920 and K-1920U attended repeater stations, by increasing the reliability of 6Zh49PDRU and 6E6PDRU tubes through more stringent quality control and testing. The major task confronting the organization at this time is automation of the operational control and technical servicing based on standardized designs for cable and microwave trunks using computers. References 9 (Russian).
[50-8225]

SYNTHESIS OF TESTS FOR PROGRAMMABLE LOGIC ARRAYS

Moscow MIKROELEKTRONIKA in Russian Vol 12, No 4, Jul-Aug 83
(manuscript received 23 Jul 82) pp 299-305

LYUL'KIN, A. Ye. and PAVLOVA, T. G.

[Abstract] A computer-operational method of devising diagnostic tests is outlined, tests for inspection of programmable logic arrays for a certain class of faults. The synthesis of such tests is demonstrated on an array which implements a set of three Boolean functions, the logic hardware consisting of MOS devices which perform negations of these functions so that in the general combinatorial case the array consists of two matrices: M^1 performing H conjunctions of L literals and M^2 performing negations of N corresponding disjunctions (a literal being any variable or its negation). The tuneup of such an array, defined as the set of states of connections between input and intermediate busbars in matrix M^1 and between output and intermediate busbars in matrix M^2 , is described by Boolean matrices $M_1 = [m_{ij}^1]$ and $M_2 = [m_{ik}^2]$, respectively. The problem of test synthesis is formulated as one of determining the set of individual faults detectable by a set of input signals. An algorithm is constructed which yields the conditions, in the form of an equality, under which a test with a set of X input signals will reveal faults in $m_{ik}^2 = O(1)$ at the k -th output port. Another algorithm is constructed for calculating the number of faults of a given class. The test is then constructed on a probabilistic basis, such a procedure being very rapid and thus quite simple in this case. The test is minimized, accordingly, by a method which involves construction of the detectability matrix and finding in it the column with only one "1" element or the largest number of "1" elements, then including in the test the set of signals for the row with the same "1" element(s). A control program organizes the solution of basic inspection problems through referral to appropriate programs, and thus enables the user to establish the proper solution sequence. The software has been written for a computer with overlap structure in a Disk Operating System, in order to ensure wide flexibility, requiring a direct-access memory with a maximum capacity of 80 kbyte only. Figures 2; tables 2; references 7: 5 Russian, 2 Western.
[65-2415]

DETECTION OF AND SEARCH FOR FAULTS IN PROGRAMMABLE LOGIC ARRAYS

Moscow MIKROELEKTRONIKA in Russian Vol 12, No 4, Jul-Aug 83
(manuscript received 31 Aug 82) pp 306-312

VOLYNSKIY, M. B. and NOVOSELOV, V. G.

[Abstract] A procedure is proposed for diagnosis of programmable logic arrays which involves generating an inspection test on the basis of the functional description of the array, performing an experiment with this test, analyzing the results for extraction of primary diagnostic data, synthesizing supplementary sets of fault locating test signals, and performing a second diagnostic experiment for final fault search. The procedure is designed to minimize both the diagnosis time and the number of indistinguishable faults (faults causing identical responses at the output), which can be necessary because of the inherent functional redundancy in programmable logic arrays. Indistinguishability of faults is demonstrated on an array which performs a cubing function of three variables, the logic hardware consisting of bipolar devices. All detectable possible faults are classified into two groups, A faults 1→0 and B faults 0→1, caused by contraction or expansion of the cube or narrowing or widening of the function. On the basis of the respective causes characterizing single faults, algorithms A1, A2, C are constructed for search of A faults and algorithm B is constructed for search of B faults. All these algorithms have been formalized with an orientation toward programmable automatic inspection of large-scale-integration systems. Figures 2; references 6: 3 Russian, 3 Western.
[65-2415]

UDC 621.373.187.4

FILTRATION OF HIGHER HARMONIC COMPONENTS IN TWO-LEVEL DIGITAL COMPUTING SYNTHESIZERS

Kiev IZVESTIYA VYSSHIKH UCHEBNIKH ZAVEDENIY: RADIOELEKTRONIKA in Russian Vol 26, No 9, Sep 83 (manuscript received 3 Jan 83) pp 29-33

FADEYEV, A. N.

[Abstract] Digital computing synthesizers of 2-level signals, built with logic microcircuits, operate by forming pulses at the zero-crossovers of given harmonic oscillations and subsequently passing those pulses through a frequency divider. Under the worst conditions, filtration of higher harmonics is most necessary in the low-frequency range, the third harmonic being the one which most significantly distorts a quasi-meander wave. An analysis of filter performance in terms of ripple factor and attenuation reveals that filters with a large time constant are most suitable for this purpose (sixth-order Butterworth, fifth-order Cauer, fifth- or sixth-order Chebyshev), a Gaussian filter not being adequate here. Furthermore, rejection of parasitic

harmonics is facilitated by connecting across the synthesizer output, before the low-pass filter, a multilevel encoder which generates a staircase approximation of a sine wave. Such an encoder consists of a pulse selector, a shift register with a parallel bank of weighting resistors, and a summator. The dependence of the ripple factor on the precision of the weighting resistors is evaluated, from the design standpoint, on the basis of the time correlation function and with the aid of the Khintchine-Wiener transformation. The results indicate that for adequate performance, the encoder must have more than four levels and the suppression level in the filter in the stop band needs only to be equal to the actual level of the second harmonic. Figures 2; tables 1; references 6: 3 Russian, 3 Western (2 in Russian translation).

[58-2415]

UDC 518.3

ART OF PROGRAMMING PROGRAMMABLE MICROCALCULATORS, PART 4: ERRORS OF CALCULATIONS

Kiev IZVESTIYA VYSSHIKH UCHEBNIKH ZAVEDENIY: RADIOELEKTRONIKA in Russian Vol 26, No 9, Sep 83 (manuscript received 4 Apr 83) pp 48-53

TROKHIMENKO, Ya. K. and LYUBICH, F. D.

[Abstract] The errors of engineering calculations made on a programmable microcalculator are defined as absolute and relative, implying the maximum in each case. The accuracy of calculations is characterized by the number of correct significant figures in the decimal readout, in the narrow sense or in the wide sense (error not exceeding respectively half a unit of a whole unit of the last digit in the mantissa). The sources of errors are classified into operational ones such as limitation of the microcalculator and its memory as well as of the software and methodical ones. Operational errors are those of rounding by discard and rounding by complementation. A sensitivity analysis revealing the dependence of absolute and relative calculation error in elementary algebraic and transcendental (exponential-logarithmic, trigonometric) operations on the error of operands indicates the limits of accuracy ranges on programmable microcalculators operating in the YaMK21 or YaMK34 language. When the results of calculations fall outside the corresponding accuracy range, then their precision must first be increased. If this does not bring the results within the desired accuracy range, then a more precise mathematical model or a better algorithm of problem solution is required. Methodical errors are reduced by increasing the number of successive approximations, i.e., retention of more terms in sums, finer discretization of the interval for numerical integration, or increasing the number of iterations. Two microcalculator programs are examined from the standpoint of accuracy: program 1/34 for addition of whole numbers with 15 or fewer figures in the mantissa of the sum and program 2/34 for multiplication of numbers with 8 or fewer significant figures in their mantissas. Figures 1; tables 1; references 6: 5 Russian, 1 Western (in Russian translation).

[58-2415]

EXAMINATION OF ANISOTROPIC FILMS BY RESONANCE METHOD

Gorkiy IZVESTIYA VYSSHIKH UCHEBNIKH ZAVEDENIY: RADIOFIZIKA in Russian
Vol 26, No 5, May 83 (manuscript received 16 Jun 82) pp 616-624

VERTIY, A. A., IVAINCHENKO, I. V., POPENKO, N. A., POPKOV, Yu. P. and
SHESTOPALOV, V. P., Institute of Radiophysics and Electronics, UkSSR Academy
of Sciences

[Abstract] The dielectric characteristics of anisotropic thin films, namely their permittivity ϵ and difference $\Delta\epsilon$ were measured by the resonance method at short millimetric wavelengths. The theory of this method is based on the solution to the diffraction problem for a plane wave and a boundless dielectric layer, with appropriate boundary conditions for reflection and conditions of a self-conjugate resonance field. The practical application of the method is determination of the natural frequencies of an open resonator formed by plane mirrors and a dielectric layer perpendicular to the resonator axis. The expression for the critical distance between resonator plates was used for processing experimental data on various materials, including a few polymers such as polyethylene, isotropic for reference and made artificially anisotropic by oriented rolling. The minimum measurable anisotropy depends on the accuracy of readings of frequency separations between resonances and on the stability of the microwave test oscillator. A resonance-type polarimeter can be used for detecting and measuring the spectrum split in weakly anisotropic films. The error of $\Delta\epsilon$ determination for films of thickness $d > 0.005\lambda$ depends essentially on the accuracy of the thickness measurement. The error of ϵ determination for films of thickness $d < 0.025\lambda$ is on the order of 3% when the theoretical expression for an open resonator is used. Figures 8; tables 1; references 13: 11 Russian, 2 Western.
[64-2415]

ESTIMATING ANGULAR POSITION OF OPTICAL RADIATION SOURCE WHEN RECEIVED BY
ARRAY OF PHOTODETECTORS

Kiev IZVESTIYA VYSSHIKH UCHEBNYKH ZAVEDENIY; RADIOELEKTRONIKA in Russian
Vol 26, No 8, Aug 83 (manuscript received after revision 12 Nov 82)
pp 85-87

VILESOV, L. D. and VEYS, V. N.

[Abstract] The angular position of an optical radiation source is measured; its field is detected by an array of photodetectors in the focal (diffraction) plane of an optical antenna. The signal and background fields are of unknown intensity. The position is determined from the coordinates of the center of diffraction pattern of the signal field in the focal plane, assuming that each element of the array filters no more than one spatial mode, while the signal and background fields are both broadband and a Poisson model applies to the electron count fields when the radiation is detected. Similitude theory is used in order to derive an optimal estimate of the vector to the source and the special case where the radiation field is received by a four-element array is analyzed. It is shown that the covariation of the estimates of the coordinates is zero in the absence of background noise. The expressions provided permit the calculations of these optimal estimates when the diffraction pattern of the signal field does not coincide with the center of the array (nontracking meter) and there are no a priori data on the intensities of the signal and background noise fields. The potential precision of the estimates obtained can be calculated with the equations provided. References 3 (Russian).

[52-8225]

KT3127A, KT3128A TRANSISTORS

Moscow RADIO in Russian No 11, Nov 83 p 60

OVSYANNIKOV, N.

[Abstract] The low-power silicon p-n-p type KT3127A, KT3128A transistors are intended for amplification, generation and conversion of high-frequency oscillations and automatic amplification control in television channel and radiochannel selectors. These planar epitaxial transistors in small metal-glass casings can be used in temperatures from -45° to 85°C and relative humidity of 98% or, without condensation, at a temperature of $40^{\circ} + 2^{\circ}\text{C}$ and can stand vibratory loads in the frequency range from 1 up to 600 Hz and acceleration up to 10 g, multiple impact loads with an acceleration of 75 g or linear loads with acceleration of 25 g. The transistor, with a mass which does not exceed 0.4 gr, is characterized by low capacity emitter and collector junction capacities, low noise levels in the high frequency ranges and sharp dependence of the amplitude coefficient on emitter current so that maximum power amplification is possible for emitter currents of 3...5 mA with attenuation of not less than 20 dB for 9 mA current. Tables present the principal electrical parameters of the transistors with an environmental temperature of $25 \pm 10^{\circ}\text{C}$, and the maximum permissible operating conditions with a temperature from -45° up to $+85^{\circ}\text{C}$.
[68-12497]

TEMO AND TEB THERMOELECTRONIC DEVICES

Moscow RADIO in Russian No 11, Nov 83 pp 59-60

GASSANOV, P., VOYTENKO, G. and VOZNAYA, G.

[Abstract] Reliable solid-state electronic microcoolers (TEMO) are being mass produced for thermostatic control of important radioelectronic circuits and can maintain necessary temperatures to fractions of a degree in the -60° to 60°C range. These devices consisting of sequences of p and n element semiconductors joined by copper plates, and with ceramic heat transfers, can withstand temperatures to 150°C . The units can be fitted together for specific needs and can utilize a battery stage (TEB) for additional power and can also function as a heater. Tellurium, bismuth, antimony and selenium semiconductor materials are used for TEMO and the best results were obtained with oriented polycrystals. The highly miniaturized elements are suitable for infrared receivers, lasers, materials research, thermosensor calibration, medical research, air conditioners and household coolers, and the like. The principal characteristics of the TEMO and TEB considered are shown.
[68-12497]

INSTRUMENTATION AND MEASUREMENTS

DIGITAL TACHOMETER

Moscow RADIO in Russian No 9, Sep 83 pp 28-29

SHIROKOV, B., Bolshiye Vyazemy (Moscow Oblast)

[Abstract] A tachometer with digital indication has been built for measuring the speed of automobile engines with only two figures (thousands and hundreds) in the rpm readout. It consists of a Schmitt trigger (one KD503B transistor) for shaping input pulses, a pulse counter (two K155IYe2 and two K155ID1 microcircuits, two IN16 indicator banks), a cycle time setting multivibrator and a readout time setting multivibrator (KT315B transistor and KT326B transistor each), a stabilizer (KT801B transistor), a flicker suppressor (KT361B transistor), and a capacitive transducer (KT602A transistor). The instrument operates from a 12 V battery and draws 180 mA. The transducer includes a 30-50 turns coil of PEL 0.5 wire wound around the conductor which connects the ignition coil to the engine distributor and its transistor is mounted on a fin-type heat sink. Tuneup of the tachometer involves matching the transducer capacitor for maximum voltage (150 V) at minimum current (80 mA) and trimming the readout time setting multivibrator with its adjustable resistor for a 1.5 readout (1500 rpm) with a 50 Hz input signal. Figures 1;
[59-2415]

UDC 621.372.632.001

GENERAL DESIGN PRINCIPLES OF HIGH SPEED FREQUENCY SYNTHESIZERS BASED ON PHASE SYNCHRONIZATION SYSTEMS

Moscow ELEKTROSVYAZ' in Russian No 10, Oct 83
(manuscript received 31 Mar 83) pp 36-42

SHAKHGIL'DYAN, V. V., PESTRYAKOV, A. V. and KABANOV, A. I.

[Abstract] When designing frequency synthesizers there is a sharp contradiction between their dynamic range and spectral characteristics. While there are various ways of resolving this contradiction, this analysis is limited to those synthesizers using indirect synthesis; they are comparatively simple and reliable, while providing a high spectral purity of the output

frequencies, although they are inferior to designs employing direct synthesis techniques. The paper deals specifically with the problem of boosting synthesizer speed by increasing the signal comparison rate in digital PLL's (Phase-locked loops). The following synthesizer configurations are discussed in a nonmathematical treatment: 1) Frequency synthesizers using dividers with a variable fractional divisor; 2) Synthesizers based on a pulse PLL, which utilize approximation frequency synthesis algorithms; 3) Synthesizers utilizing a linear transformation of the step of the frequency grid; 4) Synthesizers based on pulse PLL systems using a coarse setting accelerating input to control the tunable oscillator; 5) Frequency synthesizers which use the change in the characteristics of the control circuit in the loop; and 6) Those which make use of the establishment of favorable phase relationships with the incorporation of a PLL. Although optimal control techniques make it possible to increase synthesizer speed by approximately an order of magnitude, they are not widely used because of the complex computations which must be performed rapidly, because it is necessary to keep the PLL parameters constant with a high degree of precision. As the component base is refined (particularly microprocessors), it is anticipated that optimal control methods will be more extensively utilized in frequency synthesizer design. Figures 4; references 30; 27 Russian, 3 Western (2 in Russian translation).
[50-8225]

UDC 681.841

SOUND SIGNAL QUASI-PEAK LEVEL METERS

Moscow TEKHNIKA KINO I TELEVIDENIYA in Russian No 9, Sep 83 pp 29-31

MILLER, A. A., PRIGOZHIN, A. P, and CHERNYAVSKAYA, A. A., TsBK NPO "Ekran"
[probably Motion Picture Central Design Bureau, Scientific-Production
Association "Screen"]

[Abstract] The paper considers three new sound signal quasi-peak level meters, the 8E147, 8E149 and 8E143, which are used in sound tape recorders and amplifiers. The three units were developed at the TsBK NPO in 1982. The parameters of these level meters and their principal circuit diagrams are examined. Figures 3.

[62-6415]

STRONGLY COUPLED MILLIMETER-BAND WAVEGUIDE DIRECTIONAL COUPLERS

Kiev IZVESTIYA VYSSHIKH UCHEBNYKH ZAVEDENIY: RADIOELEKTRONIKA in Russian
Vol 26, No 8, Aug 83 (manuscript received 12 Apr 82) pp 8-11

AKHIYEZER, A. N.

[Abstract] A design technique for directional couplers, coupled through a central partition with holes paralleling the wide wall, is generalized for the case of strong coupling with 0 to 10 dB separation between the waveguides. The wave amplitude due to splitting with the propagation of the wave along the coupling system is taken into account; this coupling region is broken down into cascaded symmetrical sections where the phase constant is assumed to be the same in both waveguides. The coupling holes all have the same diameter and are equally spaced. It is assumed that reflection losses at the holes and branching back in the opposite direction as well as attenuation at the waveguide walls can be neglected. Analytical expressions are derived for the crosstalk attenuation between the channels, the insertion loss of the main channel and the directivity. A comparison between experimental data and values calculated using the derived formulas is summarized in tabular form for two couplers: the No-1068 coupler with a waveguide cross-section of 5.2x2.6 mm, having 29 holes in two rows each in the separating partition with diameters of 1.45 mm spaced 1.9 mm apart, operating in the 37.5 to 53.6 GHz band; and the No-1046 coupler with a 3.6x1.8 mm waveguide having two rows of 25 holes each with a diameter of 1.10 mm spaced 1.40 mm apart, operating in the 53.6 to 78.3 GHz band. Both couplers can be disassembled and the partitioning plate with the coupling holes and the walls are nickel plated. The agreement between experimental and calculated data is good, with the formulas being applicable to programmable calculators. Figures 1; tables 3; references 5 (Russian).
[52-8225]

APPLICATION OF FIELD SIMILITUDE THEORY TO CALCULATION OF STRIPLINE HEATING

Kiev IZVESTIYA VYSSHIKH UCHEBNIKH ZAVEDENIY: RADIOELEKTRONIKA in Russian
Vol 26, No 8, Aug 83 (manuscript received 14 Jun 82) pp 34-38

YUROV, Yu. Ya.

[Abstract] The ultimate power which can be transmitted by a stripline on a dielectric substrate is governed by the dielectric temperature. The similitude between the thermal and electrical fields has been used in earlier literature to calculate the maximum temperature of the dielectric. The potential distribution satisfies a Laplace equation, however, while the temperature distribution is determined by Poisson's equation, so that complete similitude cannot be attained. Similitude functions are derived in order to relate the electrostatic potential in the transverse plane of a stripline and a certain auxiliary function, introduced in this paper, and called the electrothermal potential. This is a function, both of the temperature and the electrostatic potential, which satisfies Laplace's equation, making it possible to circumvent the difficulty noted above. It is assumed that: 1) The dielectric parameters are independent of the temperature and spatial coordinates; 2) Heat transfer is considered only in the transverse direction and longitudinal heat transfer is negligible; 3) Metal surfaces, because of their considerable heat conductivity, are assumed to be isothermal; and 4) The temperature distribution is considered to be steady-state. A simple analytical expression is derived for the optimum characteristic impedance of a stripline used for power transmission. References 6 (Western).

[52-8225]

FUNDAMENTALS OF RADIO OPTICAL THEORY OF RESONANT AND DIRECTIONAL QUASI-OPTICAL DEVICES

Kiev IZVESTIYA VYSSHIKH UCHEBNIKH ZAVEDENIY: RADIOELEKTRONIKA in Russian
Vol 26, No 8, Aug 83 (manuscript received after revision 1 Jul 82) pp 42-48

POKROVSKIY, Yu. A.

[Abstract] With the use of approximations generally employed in quasi-optical theory (scalar, paraxial and Kirchhoff), the paper analyzes the principles of a theory in which preference is given to approximate physical models which allow for a rigorous but simple analytical description. The spectral theory of devices for shaping wave bundles having a low angular divergence utilizes an integral equation for the eigenfunctions which is reduced to an algebraic equation for the inherent angular spectrum of a Riemannian boundary value problem. The devices considered are open

resonators, open waveguides, and open resonators and waveguides with resonant angular spectrum correctors. The discussion includes the structural design of an open resonator with a specified distribution of the fundamental mode. The examples given do not exhaust the possibilities of the theory. The principle of equal local eigenvalues in the form used here and established for piecewise irregular open resonator cavities, can also be used to approximate such cavities with a specified fundamental as well as open resonator cavities with the selection of any transverse mode. The latter can be designed around resonant angular spectrum correctors. Figures 4; references 13; 11 Russian, 2 Western in Russian translation.
[52-8225]

UDC 621.372.852

WAVEGUIDE DIELECTRIC MILLIMETER BAND FILTER WITH ENHANCED SELECTIVITY

Kiev IZVESTIYA VYSSHIKH UCHEBNIKH ZAVEDENIY: RADIOELEKTRONIKA in Russian
Vol 26, No 8, Aug 83 (manuscript received 28 Jun 82) pp 61-62

BONDARENKO, A. R., MAY, V. I., NAZARENKO, L. S. and SENCHENKO, V. V.

[Abstract] Some 50 to 60 dB of isolation is necessary between the useful and image frequencies for image suppression in low-noise millimeter band receivers. This paper analyzes the structural design of a waveguide dielectric filter which can be used at the input to a low noise mixer and meet the requirements placed on the selectivity, while assuring low losses within the passband. The case of the H_{01} mode incident on a layered dielectric structure in a rectangular waveguide is considered. Expressions are derived for the transmission gain and reflection factor, as well as the input impedance of the system of coupled dielectric resonators. Curves are plotted from theoretical and experimental data to show the voltage standing wave ratio and attenuation as a function of frequency for such filters which consist of seven quartz, polikor or ceramic resonators. These waveguide dielectric filters are composed of a set of hollow waveguide sections in which the dielectric resonators metalized on the end faces are press fitted in a definite sequence. A variation in the dielectric permittivity and length of the coupled waveguide sections of 3 to 4%, or even the thickness of the dielectric resonators by 0.5% has no significant impact on the filter response. Agreement between theory and experiment is quite good as shown by the curves. Figures 2; references 7: 5 Russian, 2 Western.
[52-8225]

CALCULATING DOMINANT (QUASI-T) MODE GROUP VELOCITY IN SHIELDED MICROSTRIP LINE

Kiev IZVESTIYA VYSSHIKH UCHEBNIKH ZAVEDENIY: RADIOELEKTRONIKA in Russian Vol 26, No 8, Aug 83 (manuscript received after revision 21 Jan 83) pp 70-72

VALUYEV, K. K., ILARIONOV, Yu. A. and SMORGONSKIY, V. Ya.

[Abstract] This paper relies heavily on a technique developed by Mittra and Itoh [IEEE TRANSACTIONS, 1971, Vol MTT-19, No 1, pp 47-56] utilizing singular integral equations to arrive at a dispersion expression for a shielded microstrip line. The dispersion equation was solved on a BESM-4 computer for the normalized longitudinal wave number as a function of the frequency, after which the derivative of this wave number with respect to frequency was calculated along with the normalized group velocity. The results are plotted for the simple microstrip configuration consisting of a strip $2t$ wide on a substrate $2L$ wide and d high in a rectangular shield $2L$ wide and h high. The group velocity plotted as a function of frequency exhibits clearly pronounced minima coinciding with the inflection points of the dispersion characteristics. The existence of this minimum is explained and the retardation factor and group velocity are also graphed as a function of the frequency and t/L . The latter curves show that with an increase in t/L , the inflection point of the dispersion characteristics and the group velocity minimum coinciding with it are shifted in the direction of lower frequencies. A simple expression is given for the minimal retardation (the square root of the ratio of the partially filled shielded microstrip line capacity to the capacity of this line when the dielectric permittivity is unity). The minimal retardation initially rises with an increase in the conductor width and then falls off, tending to unity as $t/L \rightarrow 1$. Figures 1; references 2: 1 Russian, 1 Western.
[52-8225]

UDC 621.375.4.026.029.64

STUDY OF NONLINEAR DISTORTION IN MICROWAVE AMPLIFIERS USING SCHOTTKY GATE FIELD EFFECT TRANSISTORS

Kiev IZVESTIYA VYSSHIKH UCHEBNIKH ZAVEDENIY: RADIOELEKTRONIKA in Russian Vol 26, No 8, Aug 83 (manuscript received after revision 13 Sep 82) pp 81-83

GROMOV, M. V. and PETROV, G. V.

[Abstract] It is not always convenient to calculate the nonlinear characteristics of amplifiers designed around Schottky gate FET's using a nonlinear equivalent circuit for the transistors, because the determination of the circuit parameters entails large amounts of machine time and definite difficulties. Another approach is the use of transistor S -parameters, measured

at various input signal levels. The advantage is the fact that S-parameters can be found experimentally, and the computation algorithm is comparatively simple and requires much less machine time, although it is inferior in precision. The application of this method to the design of a MESFET narrow-band amplifier is described in this paper. Low-power transistors with a gate length of 1 micrometer, a width of 280 micrometers, and an active layer thickness of 0.15 micrometers with a carrier concentration of 10^{17} $1/\text{cm}^3$ were used as the active devices. The nonlinear S-parameters were measured in a power range of 0.1 to 1.5 mW at 6 GHz. The measurements served as the initial data for designing the topologies of two narrow-band amplifiers. After the geometry of the matching gamma section networks using microstrip lines was determined, a transistor was matched in one instance for the small signal case, where its S-parameters corresponding to an input power of 0.1 mW were used, while in the other case, the matching was accomplished for an input-power of 1.5 mW. The amplifier characteristics were then calculated in the input-power range at 6 GHz. Curves are plotted showing the amplifier gain and phase of the gain as a function of the input-signal power for the case when the amplifier is tuned for a maximum small signal-gain, and also for a maximum large-signal gain. The absolute value of the small-signal gain was 8.8 dB and 8.3 dB for these two cases, respectively. The third order intermodulation distortion was calculated for these two amplifiers, when two frequencies are fed to the input. The intermodulation distortion was also calculated for a balanced amplifier, in which two amplifier stages tuned for a small-signal were used. This circuit provides a significant reduction in the intermodulation signal-level, in the large case by 5 to 7 dB as compared to a single stage. Figures 3; references 4 (Western).
[52-8225]

PHOTOTHYRISTOR OPTRONS AND OPTRON MICROCIRCUITS, PART 1

Moscow RADIO in Russian No 9, Sep 83 pp 57-60

Author(s) not given

[Abstract] An optron is a device for transmission of electric signals by means of their conversion to optical ones and subsequent reconversion of the latter to electric ones. A photothyristor optron consists of two discrete galvanically isolated and optically direct-coupled components in a common housing: emitter and photothyristor. The advantages of a photothyristor optron over photoresistor and photodiode ones are higher load capacity and higher voltage rating. Its output stage is essentially a four-layer (pnpn or npnp) silicon device and its emitter is an infrared GaAs diode. With a d.c. voltage across the photothyristor electrodes and zero diode current, the photothyristor is in a nonconducting state with only a small leakage current in the output circuit. With an input signal at the diode, the photothyristor becomes conducting upon illumination of its region which has the highest electrical resistance and is oriented facing the diode. It remains so after the end of the input signal, until the output current is reduced to below its turn-off level or cut out completely by external means. The

performance parameters of thyristor optrons are classified into input parameters, intermediate parameters, and output parameters. Three series of thyristor optrons are now produced: the AOU103 and ZOU103 in standard round metal-glass housings with four output leads, and AOU115 in plastic housings. They are used for galvanic isolation of logic circuits from inductive loads, for control of thyristors and semistors, for pulse shaping, as voltage monitors and for protection of secondary power supplies, as commutator switches for indicator lamps and for matching control circuits to indicator panels. They are designed to operate with functional integrated microcircuits K295KT1A-G (d.c. relay), K295KT1A-D (optoelectric kipp-oscillator), 415KT1 (switch for control of medium-power thyristors). All these microcircuits are enclosed in metal-glass housings. Their performance specifications, in terms of similarly classified parameters, cover nominal as well as maximum permissible or attainable values. Figures 4; tables 2.
[59-2415]

UDC 621.372.839

MULTIDIODE INTEGRATED-CIRCUIT PROTECTIVE DEVICE

Kiev IZVESTIYA VYSSHIKH UCHEBNIKH ZAVEDENIY: RADIOELEKTRONIKA in Russian Vol 26, No 9, Sep 83 (manuscript received 27 Sep 82) pp 83-85

KUPTSOV, Ye. I. and TROFIMOV, V. P.

[Abstract] Asymmetric microstrip transmission lines on dielectric substrates such as Polikor are capable of carrying 100 W in the continuous-wave mode and 1 kW or more in the pulse mode, which is much more than the power rating of solid-state integrated-circuit microwave devices. Compounding of such devices will therefore raise the overall efficiency of the system. When a microstrip line is used as a protective device for a microwave switch, for instance, then its capacity can be further increased by local insertion of a symmetric microstrip segment so that twice as many diodes can be connected. A typical 8-diode device can be produced by deposition of a grounding base on each of two substrates, with a window in the conductive coating in each. In these windows identical conducting strips are deposited, whereupon diodes are connected between the ends of these strips and the respective base. Blocking capacitors and bias circuits are added, two conducting pins which connect the two grounding bases of this symmetric microstrip line providing the transition to the asymmetric one, and other conducting pins are added for suppression of parasitic resonances. Experimental prototypes of such a device were built with Bar 2A-517A diodes and tested at a maximum operating temperature of 150°C. With a 50 mA forward bias current, an incident power of 10 W did not change the voltage drop across the diodes by more than 5.5 mV. Theoretically, the peak rating of such a device should be 160 W of average microwave power. Figures 2; references 4; 3 Russian, 1 Western.
[58-2415]

MICROELECTRONICS IN COMMUNICATIONS EQUIPMENT AT 1983 LEIPZIG SPRING FAIR

Moscow ELEKTROSVYAZ' in Russian No 10, Oct 83 pp 58-64

SHLYAPOBERSKIY, V. I.

[Abstract] Companies from more than 20 nations exhibited models of their new products in practically all areas of industrial production from March 13th-19th, 1983 at the Leipzig spring fair. This paper reviews the major exhibits, providing technical specifications on the following equipment: 1) The F1000, F1100 and F1200 system teletypes of Rundfunk Fernmelde Technik (RFT) (in the GDR); 2) A Siemens teletype made in the FRG; 3) A MG80 keyboard automated morse code transceiver; 4) The Siemens HF2040, HF2055 and HF2060 facsimile sets; 5) A variety of touch tone telephones by Elektrim (Poland); 6) The 111, 150, 112, 160 and 1040 series telephones by Siemens; 7) The WL10K and WL20K intercoms by RFT as well as the EG40K6 intercom capacity expander and WL1K55-2 subscriber set; 8) The EMS electronic microprocessor system for communications switching for a variety of PBX services with the EMS10, EMS30, EMS80, EMS180, EMS600 and EMS-12000 being represented; 9) The USSR "Neva-1M" switching equipment, which is now being produced by the GDR "Robotron" combine; and 10) The KN-1E, KN5-E and KN20-E shortwave transmitters by RFT; the EKD 111/112 SSB shortwave receiver along with the EKD300 receivers RFT also offered other specialized receivers such as the EGD02/03 marine receiver and SEG100D low power SSB transceiver. Figures 7.
[50-8225]

UDC 778.38:778.5:621.375.826 + 778.38: 778.6

PULSED LASERS FOR FILMING COLOR HOLOGRAPHIC FILM IMAGES

Moscow TEKHNIKA KINO I TELEVIDENIYA in Russian No 9, Sep 83 pp 32-36

KOMAR, V. G. and SOKOLOV, V. N., All-Union Scientific-Research Institute of Motion Pictures and Photography (NIKFI)

[Abstract] A survey is made of published work, in which perspective directions for improving laser light sources for holographic motion pictures and graphic holography with a color three-dimensional image are outlined. The paper is divided into three parts: Principles of Laser Selection, Solid-State Lasers, and Dye Lasers. References 63: 42 Russian, 21 Western.
[62-6415]

SYNTHESIS OF METRICO-TOPOLOGICAL MODEL FOR LAYOUT OF TOPOLOGY OF LARGE-SCALE-INTEGRATION ARRAYS

Moscow MIKROELEKTRONIKA in Russian Vol 12, No 4, Jul-Aug 83
(manuscript received 14 Apr 82) pp 291-298

KUREYCHIK, V. M., KALASHNIKOV, V. A. and NUZHNOV, Ye. V., Taganrog
Institute of Radio Engineering

[Abstract] Design of the topology layout is the crucial item in the large-scale-integration process, inasmuch as it determines the feasibility of putting a circuit on a chip which will meet all engineering requirements and can be manufactured. The main difficulty in automated design of LSI arrays is the large number of factors which must be taken into account. Known methods of spacing and routing in a discrete field with severe constraints on circuit components and interconnections become inadequate here so that new methods using more simple and economical models must be sought. One proposed method of automated design of LSI topology begins with construction of a general model of the arrangement and interconnection of the topology fragments. As such a model, a metrico-topological one of the commutation space is chosen, the basic aim being to establish most favorable conditions for the next step of the design process: optimizing the interconnections. The spacing of topology fragments is varied and the optimum variant is sought, the generalized criterion being the minimum total length of interconnections. This criterion is the sum of partial (fragmental) criteria weighted by coefficients of their relative significance. The optimum variant is then adapted to the chip geometry and layout of real components. The procedure involves pairwise permutations of components, trial permutations continuing until the difference between the widths of interstitial zones becomes minimum. With this arrangement fixed, there follows a two-step construction of an orthogonal Steiner tree for the last step of the design process: dimensioning the topology layout and separation of tiers superposed on the drawing. Advantages of this method are that it takes into account structural and technological factors in cellular layout, provides for control of the chip structure, does not require fixation of fragments, and monitors changes in quality during optimizing iterations. Unlike conventional routing methods, it has flexibility to changes in resources and provides total feasibility estimates. Figures 1; references 5; 4 Russian, 1 Western.
[65-2415]

SYNTHESIS OF HIGH-SPEED DEVICES USING INTEGRATED OPERATIONAL AMPLIFIERS

Moscow MIKROELEKTRONIKA in Russian Vol 12, No 4, Jul-Aug 83
(manuscript received 20 Jan 83) pp 313-319

AGAKHANYAN, T. M., Moscow Institute of Engineering Physics

[Abstract] Integrated operational amplifiers include corrective networks preventing self-excitation but also reducing the speed. Although the stability margin of these networks is usually much wider than needed in analog devices, it is necessary to ensure instead the minimum speed reduction. This imposes stringent constraints on the transient response characteristics such as maximum permissible rise time and overshoot amplitude, as well as on the corner frequency and the nonuniformity of the amplitude- or phase-frequency characteristic. These requirements are examined here quantitatively by the method of transfer functions in feedback systems. The relations between corresponding coefficients in the two transfer functions, of the feedback device and of the corrective network, respectively, yield two systems of equations: one for the numerators and one for the denominators (coefficients in the characteristic equation). The former is used for synthesis of networks with zeros, the latter yields a fundamental ratio for electron devices with feedback. In the synthesis of such a device, accordingly, one must strive for a characteristic equation with real roots for the transfer function of the feedback loop and one with the largest possible imaginary parts of the complex roots for the amplifier gain. For complete matching of design with performance requirements, the corrective network must have as many loops and thus degrees of freedom as there are equations. These principles are demonstrated on the 153UD2 operational amplifier with two poles in the basic transfer function, with two stray capacitances, and with a resistive voltage divider for the feedback signal. A corrective network which has no zeros and does not raise the degree of the characteristic equation is designed for operation of this amplifier under a large capacitive load with a maximum rise time $\tau = 0.15 \mu\text{s}$ and an overshoot amplitude not exceeding 15%. With stray shunting capacitances at the output and with slow power transistors, this operational amplifier must be described by a transfer function with three poles. Numerical values of the various parameters are obtained on this basis. References 4: 3 Russian, 1 Western (in Russian translation).

[65-2415]

CHARACTERISTICS OF OPTICAL INFORMATION-MEASUREMENT CHANNELS WITH UTILIZATION OF SCATTERING EFFECTS

Kiev IZVESTIYA VYSSHIKH UCHEBNYKH ZAVEDENIY: RADIOELEKTRONIKA in Russian
Vol 26, No 9, Sep 83 (manuscript received 10 May 82) pp 10-14

BYCHKOV, S. I., PAVLOV, V. N. and SHEVYAKOV, M. M.

[Abstract] Optical channels which utilize scattering effects for measurement and data transmission are considered, a typical one being a spatially bounded laser beam propagating through the atmosphere, and their main advantage being that the photoreceiver aperture need not be illuminated from the transmitter directly. The frequency characteristic of such a channel and the space-time characteristics of such signals are calculated for the basic configuration with a pencil-beam source and an offset receiver. On the basis of expressions for the photodetector current and the dispersion of normal joint signal-noise distribution, the aperture function of the receiver antenna and the postphotodetection channel (filter-multiplier-threshold device) are optimized for a maximum signal-to-interference power ratio at the input to the threshold device. Calculations reveal that a rectangular aperture function is the optimum one and that the signal-to-interference power ratio increases monotonically with an increasing angle of vision, but only as long as the latter does not exceed the angular dimensions of the laser pencil beam. Figures 3; references 4 (Russian).
[58-2415]

BINARY SIGNAL DETECTION IN ACOUSTOOPTIC RECEIVERS

Kiev IZVESTIYA VYSSHIKH UCHEBNIKH ZAVEDENIY: RADIOELEKTRONIKA in Russian
 Vol 26, No 9, 1983 (manuscript received 16 Sep 82) pp 75-77

[Article by A. V. Pugovkin]

[Text] The noise stability of acoustooptic (AO) frequency meter-receivers (AOPCh) and spectral analyzers (AOAS) was considered in [1], where the probability of signal detection in the frequency channels of the receivers was found in approximation of a normal random process at the input of the threshold device. The authors used the method of calculating the statistical characteristics for the intensity of diffracted light and subsequent finding of the detection characteristics by normalization of the process.

A different method of solving this problem is proposed in this paper, when the characteristics of the random process at the input of the device are given and their conversions upon passage through the main components are then considered. With this approach, one can in some cases do away with the model of the normal process, which is not always applicable to calculation of acoustooptic devices.

A diagram of the acoustooptic frequency meter-receiver is presented in Figure 1, a. The received signal of frequency Ω is amplified by a wideband amplifier 1 and excites ultrasonic oscillations in the acoustooptic modulator (AOM) 2. The emission of a laser L of frequency ω , shaped by optical system 4, is diffracted on ultrasound and is focused by lens 5 onto the surface of a photo-detector (a photodiode strip) 6. The signals from the output of the photo-detector are amplified by video amplifier 7 and are fed to threshold device 8, where their value is compared to the threshold U_p .

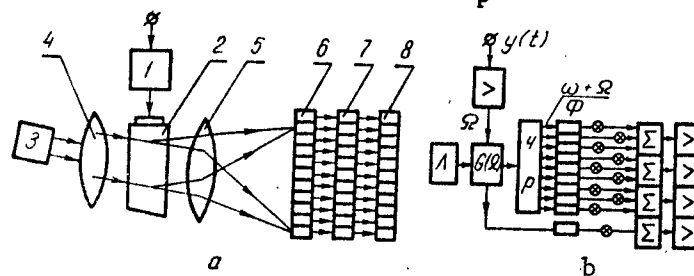

Figure 1

To calculate the detection characteristics, let us compose the equivalent circuit (Figure 1, b). The acoustooptic modulator here is represented in the form of an octopole with frequency characteristic $G(\Omega)$, at the outputs of which there are two signals corresponding to the diffracted and non-diffracted beams. If the input signal is non-monochromatic, the first of them contains several components having their own complex amplitude and frequency $\omega + \Omega$. The lens and sections of the free space in the dual circuit are represented in the form of a frequency splitter ChR and an infinite set of spatial filters with identical frequency characteristics $R(\Omega)$ and with different central frequencies Ω_x . The type of function $R(\Omega)$ is determined by the Fourier transform of the bandpass function of the input window of the acoustooptical modulator $r(x)$. The adder shows the process of integration of the photoelectric signal on the surface of the individual component of the photodetector (quadratic detector D).

Let us consider the effect of a signal $s(t)$ and noise $n(t)$ signal on the input of an acoustooptic frequency meter-receiver. Let us find the probability of an excess of the threshold value U_p by the mixture $y(t) = s(t) + n(t)$, using the equation of a generalized acoustooptic spectral analyzer [2]. The luminous field intensity at the input of the quadratic photodetector $E_{\Sigma}(\Omega_x, t)$ is a narrowband random process, since the random signal passes through the filter with characteristic $R(\Omega - \Omega_x)$.

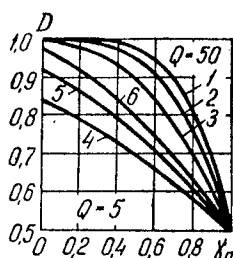

Figure 2

If the signal exceeds noise, the law of amplitude distribution of the mixture at this point of the circuit can be regarded as normal [3] with mean value

$$m_A = A_c [1 + \sigma_n^2 / (2A_c^2)] \quad (1)$$

and standard deviation

$$\sigma_A^2 = \sigma_n^2 [1 + \sigma_n^2 / (A_c^2)]^2, \quad (2)$$

where

$$A_c(\Omega_x, t) = B \int_{-\infty}^{\infty} R(\Omega - \Omega_x) F(\Omega) e^{i\Omega t} d\Omega; \quad [\sigma_n^2 = N_0 / (2\pi) \int_0^{\infty} |R(\Omega - \Omega_x)|^2 d\Omega \approx N_0 \Delta\Omega_x / (2\pi);$$

N_0 is the spectral density of the noise output at the input of the spatial filter, $\Delta\Omega_x$ is its bandwidth, $F(\Omega)$ is the signal spectrum and $B = \text{const}$.

Let us now find the statistical characteristics at the output of a quadratic detector with characteristic $\eta = ay^2$ [3]:

The probability distribution density is

$$P_c(\eta) = 1/(2\sigma_A \sqrt{2\pi a\eta}) \left[e^{-\frac{(V\sqrt{\eta/a} - m_A)^2}{2\sigma_A^2}} + e^{-\frac{(V\sqrt{\eta/a} + m_A)^2}{2\sigma_A^2}} \right] \eta \geq 0 \quad (3)$$

the mean value is

$$P_c(\eta) = 0, \quad \eta < 0;$$

$$m_\eta = am_A^2 \sqrt{2\sigma_A^2/m_A^2 + 1}$$

and the standard deviation is

$$\sigma_\eta^2 = 2a^2\sigma_A^4 (1 + 2m_A^2/\sigma_A^2).$$

The random processes of different point detectors, which can have different degree of correlation, are then added. Therefore, let us consider the following cases:

1. The dimension of the photodetector along axis Ω_x is compared to the resolution of the acoustooptic frequency meter-receiver by frequency. For a rectangular input window measuring D , this condition is written in the form $\delta\Omega_x \leq V/D$. In this case the signals at all the points of the photodetector will be correlated and the total signal will be described by distribution (3). Let us find the probability of an excess threshold level U_p

$$D(\Omega_x, t) = \int_{\gamma_n}^{\infty} P_c(\eta) d\eta = 2 \left\{ 1 - \frac{\Phi[q(\Gamma_n + 1)] + \Phi[q(\Gamma_n - 1)]}{2} \right\}, \quad (4)$$

where

$$\Gamma_n = \gamma_n^2 = \sqrt{U_p/a}/m, \quad q = \sqrt{Q} [1 + 1/(2Q)] / \sqrt{1 - 1/Q}.$$

Q is the signal/noise ratio at the input of the space filter.

The dependence of D on the threshold value at different values of Q is presented in Figure (curves 1 and 6). Their main feature is that the probability of detection is close to unity in the range of $U_p/(am_A^2) \approx 0$. This result differs from the data of [1], in which the signal/noise mixture at the output of the quadratic detector is described by normal law, which is not fulfilled in this case due to strong correlation of the processes at the outputs of point photodetectors.

2. The dimensions of the photodetector along the axis Ω_x is much greater than the resolution $\delta\Omega_x/(2\pi) \gg V/D_a$

Let us consider the case when the signal and photodetector were as before, but the aperture of the acoustooptic modulator was increased. A large number of uncorrelated spectral noise components will then be superimposed at the aperture of the photodetector and the output process at the output of the adder can be regarded as normal with mean value $m_\Sigma \approx m_\eta$ and with standard deviation $\sigma_\Sigma^2 = \sum_i \sigma_{\eta_i}^2 \approx \sigma_\eta^2$ the same as in the previous case. The probability of detection is described here by the expression

$$D \approx \Phi [m_{\Sigma}/\sigma_{\Sigma} (U_n/m_{\Sigma} - 1)]. \quad (5)$$

Numerical calculations for this case are presented in Figure 2 (curves 2 and 5), from which it is obvious that determination of the signal is less probable with normal law.

These calculations do not take into account the internal noise of the photodetector, which is especially easy to do for the second case. If the photodetector noise is white noise with mean value $m_{\phi} = 0$ and with standard deviation σ_{ϕ}^2 , we find that all the previous arguments are valid if the value of σ_{Σ} in (5) is replaced by $\sigma_{\Sigma}(1 + \sigma_{\phi}^2/\sigma_{\Sigma}^2)^{1/2}$. The probabilities of detection, calculated at $\sigma_{\phi}^2 = \sigma_{\Sigma}^2$ and presented in Figure 2 (curves 3 and 4) are in good agreement with the results found in [1].

The calculations permit one to conclude that the dimensions of the photodetector must be matched with the frequency resolution and also with the dimensions of the diffraction light spot from the received signal in an acoustooptic frequency meter-receiver to increase the probability of detection. If the dimensions of the photodetector are less than the diffraction spot, then only part of the signal energy will participate in the process of detection. The length of the signal τ should be equal to D_a/V for a simple radio pulse. This condition is not compulsory for addition of the signals, since the spectral components of the signal here, like noise, also illuminate several components of the acoustooptical frequency meter-receiver to be resolved.

BIBLIOGRAPHY

1. Kremer, I. Ya., V. A. Golub and G. S. Nakhmanson, "Measuring the Bandwidth of Pulsed Radio Signals by an Acoustooptoelectronic Spectral Analyzer on a Background of External and Internal Additive Noise," in "Akustoopticheskiye metody obrabotki informatsii" [Acoustooptic Methods of Data Processing], Leningrad, Izdatel'stvo "Nauka", 1978.
2. Pugovkin, A. V., "On the Theory of Bragg-Type Acoustooptic Spectral Analyzers," AVTOMETRIYA, No 3, 1981.
3. Tikhonov, V. I., "Statisticheskaya radiotekhnika" [Statistical Radio Engineering], Moscow, Izdatel'stvo "Sovetskoye radio", 1967.

COPYRIGHT: "Izvestiya vysshikh uchebnykh zavedeniy MV i SSO SSSR. Radioelektronika", 1983.

6521

CSO: 8144/0276-C

ASYMMETRY OF DIFFRACTION ORDERS WITH LIGHT DIFFRACTION AT SURFACE ACOUSTIC WAVE

Kiev IZVESTIYA VYSSHIKH UCHEBNIKH ZAVEDENIY: RADIOELEKTRONIKA in Russian
Vol 26, No 8, Aug 83 (manuscript received 5 Apr 82) pp 38-42

VOLOSHINOV, V. B., PARYGIN, V. N. and TANKOVSKI, N. S.

[Abstract] It is usually assumed that the light wavelength is shorter than the ultrasonic wavelength in the theoretical analysis of optical ray diffraction at a surface acoustic wave. At ultrasonic frequencies where the wavelengths are less than an order of magnitude different from the optical wavelengths, disregarding the latter produces errors in the determination of the diffracted light intensity as a function of the angle. This paper analyzes SAW diffraction of light for arbitrary ratios of the sound and light wavelengths. The experimental check of the derived expressions employed a SAW excited on a lithium niobate crystal in a sound frequency range of 30 to 340 MHz. Curves are plotted for the experimental and theoretical values, showing the diffraction efficiency of the first diffraction orders as a function of the angle, for frequencies of 185 and 340 MHz. The agreement demonstrates that the problem of light diffraction at a SAW is solved; the asymmetry in the diffraction pattern of light scattering at ultrasonic SAW's is governed by the structure of the acoustic wave, depends on the frequency, the number of the diffraction order and the angle of optical ray incidence. Figures 1; tables 1; references 4: 2 Russian, 2 Western. [52-8225]

BINARY DETECTION OF SIGNALS IN ACOUSTOOPTIC RECEIVERS

Kiev IZVESTIYA VYSSHIKH UCHEBNIKH ZAVEDENIY: RADIOELEKTRONIKA in Russian
Vol 26, No 9, Sep 83 (manuscript received, after revision, 16 Sep 82)
pp 75-77

PUGOVKIN, A. V.

[Abstract] An acoustooptic frequency meter is considered which consists of an amplifier of acoustic input signals and an ultrasonic modulator-diffractor of a laser beam, a lens for focusing the diffracted light on a photoreceiver comprising a linear array of photodiodes, a video amplifier of photoreceiver output signals, and a threshold device. The detection probability characterizing the interference immunity of the acoustooptic receiver is evaluated without restrictions on the characteristics of a random process at the input of the threshold device. Accordingly, the transformations of these characteristics in the components of the threshold device are tracked and it is not necessary to assume a normal random input process. Calculations are based on representing the modulator as an equivalent octupole network with known frequency characteristic $G(\Omega)$ and two output signals corresponding, respectively, to diffracted and undiffracted light. In the case of a polychromatic input signal to the modulator the latter's first output signal will have several components with complex amplitude and a frequency $\omega + \Omega$ each. On this basis the probability is calculated of an input signal+noise mixture to the threshold device exceeding the threshold level. Summation of random processes coming from different point detectors (photodiodes) with possibly different correlations depends on the photoreceiver dimension along the Ω_x -axis relative to the frequency resolution of the instrument. Two practical cases to be considered are those of the photoreceiver dimension, respectively, comparable with or much larger than the frequency resolution. Figures 2; references 3 (Russian).
[58-2415]

MEAN INTENSITY OF WAVE REFLECTED BY WAVEFRONT REVERSING MIRROR IN TURBULENT MEDIUM

Gorkiy IZVESTIYA VYSSHIKH UCHEBNYKH ZAVEDENIY: RADIOFIZIKA in Russian
Vol 26, No 5, May 83 (manuscript received 30 Jun 82) pp 579-586

MALAKHOV, A. N., POLOVINKIN, A. V. and SAICHEV, A. I., Gorkiy State
University

[Abstract] The mean intensity of a wave after its reflection by a wavefront reversing mirror in a turbulent medium is calculated, assuming that both incident and reflected waves propagate along the same longitudinal axis of coordinates. Both waves are described in a low-angle quasi-optical approximation, the incident wave originating from a point source. The medium is assumed to be stationary, its inhomogeneities not having time to change during the entire forward and backward travel of the wave. The results reveal that over short routes the mean intensity of the reflected wave is equal to its intensity in a vacuum. Over long routes, however, the profile of the mean intensity depends on the mirror size. Large mirrors fully compensate the effect of turbulence. Medium-size mirrors produce a profile which has a narrow peak with a radius equal to the coherence radius and a low but wide pedestal covering most of the wave cross section. The mean intensity of a wave reflected by a small mirror is equal to that of a wave reflected by a plain mirror of the same dimensions. Mirrors with a characteristic dimension much larger than the coherence radius always amplify the wave intensity at the source point. References 8: 6 Russian, 2 Western (1 in Russian translation).
[64-2415]

THIRTY-EIGHTH CONFERENCE ON 'RADIO DAY'

Moscow ELEKTROSVYAZ' in Russian No 9, Sep 83 pp 59-60

ISHUTINA, L. N.

[Abstract] A conference on "Radio Day" was held in May 1983 in Moscow by the Scientific-Technical Society of Radio, Electronics, and Communication Engineers imeni A. S. Popov with three USSR Ministries (Communication, Communication Equipment Industry, Higher and Secondary Special Education), the USSR Academy of Sciences, and the USSR State Committee on Radio and Television Broadcasting. The participants included approximately 400 scientists and specialists from 60 Soviet cities and 56 foreign scientists and specialists from 7 other socialist countries (including Yugoslavia) and Finland, also from ITTCC and IRCC. The presentations covered progress in information sciences, in telegraph communication, and in postal service, problems of labor productivity in the communication sector, progress in and outlook for television broadcasting in the USSR, demographic and climatic problems pertaining particularly to rural areas, and use of satellites for safer navigation on seas. References 1 (Russian), [61-2415]

UDC 771.449.76.058.2

CORRECTIVE LIGHT FILTERS FOR COLOR UNDERWATER FILMING

Moscow TEKNIKA KINO I TELEVIDENIYA in Russian No 9, Sep 83 pp 16-20

KOMOLIKOV, M. G., KURITSYN, A. M., KHOLIN, I. A. and SHLYAKHTER, Ye. M., All-Union Scientific-Research Institute of Motion Pictures and Photography (NIKFI); "Central Scientific Film" Motion Picture Studio

[Abstract] The history of underwater filming in the USSR is briefly considered, the importance of such filming is shown, and the special technological features of the filming and equipment imposed by the water medium is discussed. Data are presented on the KPSP underwater film corrective light filter developed at NIKFI for filming in the coastal littorals of the Black Sea and in other water units which pertain to Type 1 water. These light filters can be placed on the lens of motion picture equipment during filming with the use of daytime-type film and illumination by natural light or artificial sources of daylight, as well as employment as illuminating light filters for instruments with incandescent lamps during filming using type LN film. Detailed technical data concerning work at NIKFI are presented in tables and figures. The KPSP-3 and KPSP-5 film underwater light filters were tested by specialists of the "Central Scientific Film" Motion Picture studio in coastal littorals of the Black Sea in the Crimea. The method of testing is briefly described. Figures 4; references 6: 4 Russian, 1 Western in Russian translation, 1 German. [62-6415]

CALCULATION OF SURFACE FINISH OF SCREEN

Moscow TEKHNKA KINO I TELEVIDENIYA in Russian No 9, Sep 83 pp 25-28

DYBCHINSKI, V. I. (Polish People's Republic)

[Abstract] The paper analyzes the effect of the surface finish on the magnitude of the luminance factor for motion picture screens. The illumination engineering requirements on the screen material, the directivity of reflection from the elemental surface, and the finish of the screen material in which all the screen surface is covered by spherical units of small dimension are considered. In the method presented for designing the surface finish, the effective distribution of the luminous intensity of the elementary surface of the screen material is taken into account. Use of the spherical finish makes it possible to achieve a sufficiently good uniformity of the luminance factor within the limits of the specified effective angle. In the case of a dissipative surface, use of the surface finish does not give satisfactory results; the value of the luminance factor is too small in comparison with materials of large directivity. Figures 4; references 9: 2 Russian, 3 Polish, 3 Western.
[62-6415]

CSO: 1860

- END -