

128091

JPRS-EPS-85-038

27 March 1985

19981105 111

# East Europe Report

POLITICAL, SOCIOLOGICAL AND MILITARY AFFAIRS

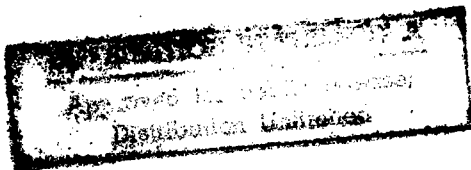

DTIC QUALITY INSPECTED 3

**FBIS**

FOREIGN BROADCAST INFORMATION SERVICE

REPRODUCED BY  
NATIONAL TECHNICAL  
INFORMATION SERVICE  
U.S. DEPARTMENT OF COMMERCE  
SPRINGFIELD, VA. 22161

6  
126  
A07

#### NOTE

JPRS publications contain information primarily from foreign newspapers, periodicals and books, but also from news agency transmissions and broadcasts. Materials from foreign-language sources are translated; those from English-language sources are transcribed or reprinted, with the original phrasing and other characteristics retained.

Headlines, editorial reports, and material enclosed in brackets [] are supplied by JPRS. Processing indicators such as [Text] or [Excerpt] in the first line of each item, or following the last line of a brief, indicate how the original information was processed. Where no processing indicator is given, the information was summarized or extracted.

Unfamiliar names rendered phonetically or transliterated are enclosed in parentheses. Words or names preceded by a question mark and enclosed in parentheses were not clear in the original but have been supplied as appropriate in context. Other unattributed parenthetical notes within the body of an item originate with the source. Times within items are as given by source.

The contents of this publication in no way represent the policies, views or attitudes of the U.S. Government.

#### PROCUREMENT OF PUBLICATIONS

JPRS publications may be ordered from the National Technical Information Service, Springfield, Virginia 22161. In ordering, it is recommended that the JPRS number, title, date and author, if applicable, of publication be cited.

Current JPRS publications are announced in Government Reports Announcements issued semi-monthly by the National Technical Information Service, and are listed in the Monthly Catalog of U.S. Government Publications issued by the Superintendent of Documents, U.S. Government Printing Office, Washington, D.C. 20402.

Correspondence pertaining to matters other than procurement may be addressed to Joint Publications Research Service, 1000 North Glebe Road, Arlington, Virginia 22201.

27 March 1985

**EAST EUROPE REPORT**  
**POLITICAL, SOCIOLOGICAL AND MILITARY AFFAIRS**

**CONTENTS**

**CZECHOSLOVAKIA**

Czechoslovak Dissident Pelikan on Division of Europe (Jiri Pelikan; EL PAIS, 20 Feb 85) .....	1
Report on Work at Gabcikovo Project (Miloskav Vltavsky; RUDE PRAVO, 22 Feb 85) .....	4
<b>Briefs</b>	
Cooperation With Ethiopia	5
Fire Damages Economy	5
Developing Countries' Journalists' Training	5
Antitank Missiles	5

**GERMAN DEMOCRATIC REPUBLIC**

Problems Encountered in Digital Communications Equipment (W. Hanisch, L. Voigt; MILITARTECHNIK, No 1, 1985) .....	6
--	---

**HUNGARY**

Trade Union Council Secretary Comments on Reform (Laszlo Bukta Interview; MAGYAR NEMZET, 17 Jan 85) .....	14
Role of Religion in Society (Miklos Tomka; KRITIKA, Jan 85) .....	18

**POLAND**

Efforts To Raise Agricultural Fund Detailed (PRZEGLAD KATOLICKI, No 6, 10 Feb 85) .....	26
Bujak's Stand on Economic Restrictions Criticized (Krzysztof Krauss; TRYBUNA LUDU, 25 Feb 85) .....	27

Political Weeklies Voice Sharp Disagreement (Various sources, various dates) .....	30
Rem's Distortions Economic Inaccuracies, by Jan Rem	
Czyrek Addresses Przemysl Party Conference (Anna Pawlowska; TRYBUNA LUDU, 7 Mar 85) .....	37
Information Used To Attack Tokarczuk Expended (RZECZPOSPOLITA, 28 Feb 85) .....	39
Work on Constitutional Tribunal Nears Completion (RZECZPOSPOLITA, 28 Feb 85) .....	42
Vatican's Hypocritical Human Rights Campaign Attacked (GAZETA KRAKOWSKA, 11 Feb 85) .....	44
Catholic Weekly Accused of Dishonest Journalism (Eugeniusz Guz; RZECZPOSPOLITA, 26 Feb 85) .....	48
Boundaries of Collective Bargaining Process Outlined (RZECZPOSPOLITA, various dates) .....	52
Purpose of Collective Bargaining, by Maria Matey Trade Union Speaks Out	
Academy of Sciences Publishes Action Program for 1984-1986 (NAUKA POLSKA, No 4, 1984) .....	58
Policy on Punishing Offenders Outlined (RZECZPOSPOLITA, 15 Feb 85) .....	73
Briefs	
New Trade Union	76
Mokrzyszczak With ZYCIE PARTII	76
Messner Witnesses Accord Signing	76
Kalkus in Poznan	76
Kubiak in Krakow	76
Glowczyk in Lodz	76
Soviet TU Delegation Visits	76
Soviet Education Delegation Visits	77
Hungarian TU Official Visits	77
Jaruzelski Receives SPD's Ehmke	77
New Editor of TU I TERAZ	77
Executive Program With India	77

ROMANIA

Roundtable on Stages, Continuity of Revolutionary Process (Marin Badea, et al.; ERA SOCIALISTA, No 21, 10 Nov 84) .	78
--	----

Speech at Prague Conference on International Communist Review  
(Ion Soian; ERA SOCIALISTA, No 3, 10 Feb 85) ..... 108

YUGOSLAVIA

Veterans' Federation Official on Nationalism  
(TANJUG Domestic Service, 3 Mar 85) ..... 114

Belgrade LC Commission Criticizes 'POLET' Adventurism  
(DANAS, 5 Feb 85) ..... 117

Blazevic's Belated 'Revelations' on Stepinac Trial  
(Viktor Meier; FRANKFURTER ALLGEMEINE, 8 Mar 85) ..... 119

CZECHOSLOVAKIA

CZECHOSLOVAK DISSIDENT PELIKAN ON DIVISION OF EUROPE

Madrid EL PAIS in Spanish 20 Feb 85 pp 9-10

[Article by Jiri Pelikan, former director of Czechoslovak television and an Italian Socialist Party deputy in the European Parliament: "Overcoming the Division of Europe"]

[Text] It is paradoxical that the defenders of Yalta and those who would like to free themselves of it are both convinced that the world was divided up at Yalta under an agreement among the USSR, the United States and the United Kingdom and that any shift in this situation would question the agreement and the consequences of the Second World War. The Yalta division of Europe, or of the world, is not, however, based on any document from the conference or on any testimony from the participants.

On the contrary, among the documents of the Yalta Conference was a declaration on liberated Europe, in which the three powers affirm their desire "to lend assistance to the peoples liberated from Nazi domination, in order to resolve, through democratic methods, their political and economic problems...and to create democratic institutions of their choice." The three great powers "will by common agreement help all the peoples of liberated Europe...to form provisional governments that fully represent all democratic elements and that will pledge to establish, as soon as possible through free elections, governments that are in keeping with the will of their peoples."

So then, the three great powers did not conspire against Europe as such; rather, as Jean Laloy says, "one of them absorbed Eastern Europe" ("Entre guerre et paix," Plon, Paris, 1983). What divided Europe was the Soviet view that any country that became communist must remain communist forever and that any attempt to democratize or reform the system would be regarded by the USSR as counterrevolutionary, meaning that Moscow could intervene militarily or in other violent ways. This view creates inequality in international relations and, therefore, permanent tension.

The most important issue, however, is whether we can leave behind this logic of a world divided between superpowers, be it part of the Yalta agreements or not.

The best way of doing this would be to strengthen and develop the European Community, even though we realize that, for the time being, it represents only part of Europe and, therefore, cannot speak on behalf of the entire continent, to which the peoples of Central Europe also belong. To expand the community and to strengthen it so that it can overcome its economic crisis and defend and expand democracy, democratic public opinion should support the European union project that the European Parliament approved in February 1984 and that President Mitterrand supports. The project is a wideranging reform of the Treaties of Rome and would transform the community into a true European union politically, economically, culturally and in the area of joint security.

Another way is to promote a fair detente, which is not the confirmation or even the consolidation of the political status quo, in other words, the division of Europe. On the contrary, a fair detente would overcome this division by means of reforms that would enable nations to freely choose their own models of development and ways of life without running the risk of armed intervention by one or the other superpower.

The practical difference between these two views of detente can be seen in the contacts between Western and Eastern European countries. When I am asked whether invitations to visit the countries of Eastern Europe ought to be accepted, I always say yes, because I feel that the policy of isolation is not good for the peoples in the Soviet bloc. So then, I say yes, but we have to avoid one-sided contacts and, therefore, demand the right to also visit people who are not in power and who think differently than the government does. How many politicians, how many parties in power, how many opposition parties that have traveled to Moscow to meet with Soviet leaders have tried to see Sakharov, for example? How many politicians have gone to Warsaw without asking to visit with Lech Walesa and the leaders of Solidarity? The same goes for Prague, Berlin, Budapest, etc. How many lawyers who have shown such courage in visiting political prisoners in Chile, Turkey or Uruguay, have gone to Prague to visit Rudolf Battek, the socialist who has been in jail for 5 years, or his family?

This holds for all relations between the countries of the Western and Eastern blocs, political, economic, cultural, scientific and otherwise. If we want to help overcome the current division, we must promote all direct contacts between peoples so as to end their isolation and spread the European spirit and solidarity in general.

There are great possibilities in the cultural field. First of all, Europe's cultural identity should be reinforced through a familiarity with the works of art of the great European artists and writers of the past and present. It would be necessary, above all, to help the writers in Eastern European countries who have been condemned to remain silent or who are limited to the samizdat, by translating their works and then publishing them in the West. Universities and

scientific institutions could invite professors and scholars who have been forbidden to practice their professions in their own countries to give lectures or could offer them research fellowships. And let us not forget young people, in particular (scholarships, exchanges of groups and individuals, joint vacation camps, etc).

All of this could be done concurrently with official exchanges and contacts, which touch only a small portion of Eastern European society.

Satellite television could be decisively instrumental in overcoming the division of Europe, as it would cross the borders of both countries and blocs. Unfortunately, however, Western governments are not aware of its great potential and for the time being are readying themselves for the era of "television without borders" with legal battles over who is going to pay for advertising and copyrights.

Change and reform in the countries of Eastern Europe, which are absolutely essential in overcoming the current division gradually, are not possible without access to information and without some degree, albeit limited, of freedom of expression. For this reason, the issue of human rights is becoming the focus of the political struggle in the countries of Eastern Europe. We have a duty to support this trend, to defend the citizens who are being persecuted because of their commitment to this struggle and to give it as much publicity as possible in the West. Moreover, the struggle for peace, which the West widely regards as the main task, is closely linked, in Eastern Europe, to the struggle for civil rights. If we want to have a Europe free of nuclear weapons from Portugal to the Urals, we must have public opinion simultaneously pressure both blocs and both superpowers. Peace will result from universal, not unilateral action. Peace will be much better guaranteed when we can demonstrate in the street against the arms race not only in Rome, London or Brussels but in Prague, Warsaw, East Berlin and in Moscow too.

Let us reject, then, the division of Europe and of the world at Yalta 40 years ago and let us return instead to the principles set forth in the conference's declaration on liberated Europe, which acknowledges the right of all European nations to democratically choose the system under which they wish to live. The current division of Europe is a source of suffering for many nations, which are being denied this right. It insures neither peace nor stability; on the contrary, it is a source of permanent tensions and of possible conflicts and explosions. Overcoming the division of Europe gradually and through various avenues is a deep-seated ambition of the peoples of Europe and would be a major contribution to maintaining peace in the world.

8743

CSO: 3548/91



27 March 1985

CZECHOSLOVAKIA

## REPORT ON WORK AT GABCIKOVO PROJECT

AU040730 [Editorial Report] Prague RUDE PRAVO in Czech on 22 February on page 5 carries a 1,000-word article by Miloskav Vltavsky entitled: "All the Functions of the Danube." The article deals with construction progress at the Gabčíkovo hydroelectric power plant, the Czechoslovak section of the joint Czechoslovak-Hungarian Gabčíkovo-Nagymaros Danube project. The author first discusses some technical specifications of the "remarkable" project and its many "beneficial contributions." He notes that the power station's planned "eight Kaplan turbines coupled with hydroalternators will be capable of up to 720 megawatts output"; that the project will improve navigation on the Danube since the entire Czechoslovak section of the Danube up to Nagymaros in Hungary will have a "sufficiently wide path of navigation and a depth of at least 3.6 to 4 meters"; and that "after the completion of the barrage there should not be any recurrence of catastrophic floods" such as the one in 1965. In addition, "farmers as well as industry will here draw water, which is one of the prerequisites of a further intensive development of production in the Danube lowlands" and the newly created vast water areas" will offer good conditions for sports and recreation and will have a favorable impact on the microclimate of the adjacent area."

According to the article, "Nothing comparable has been built in southern Slovakia so far. The entire construction site has a length of 160 kilometers. The cost of construction will be similar to the cost of a nuclear power plant and the construction itself will spread across more than a decade." The great costs are due mainly to the "virtually bottomless gravel sand" at the site of the future power plant and lock chambers. According to engineer Alfred Lacko from the Hydrostav enterprise, "we spent more than 3 years and large sums of money to stabilize the bottom plate of the future tub underneath these two objects. Through drilling into a depth of tens of meters, we formed an almost watertight layer consisting of 80,000 cubic meters of self-hardening suspension. The foundations of the objects will thus be laid up to 33 meters below the underground water level."

Aside from the power plant itself, Vltavsky goes on to say, the Gabčíkovo project also comprises the construction of a 16-km long and 4-km wide storage lake at Hrusov-Dunakiliti with a volume of 240 million cubic meters of water and of a 17-km long diversion channel leading to the power plant, which will be almost 15 meters deep and up to 750 meters wide. This diversion channel will reportedly carry "almost the entire Danube water at a distance of up to several kilometers from the old riverbed." It will be only after the power plant's turbines and a passage through an 8-km long tail channel that the Danube water will return to the old river bed, near Palkovicovo, Vltavsky says in concluding.

CZECHOSLOVAKIA

BRIEFS

COOPERATION WITH ETHIOPIA--A cultural cooperation program between the CSSR and Socialist Ethiopia for the years 1985-1987 was signed yesterday [26 February] in Prague by Vladimir Cerevka, deputy minister of culture of the Slovak SR, and Sewde Gurmu, deputy minister of culture of Socialist Ethiopia. The document establishes the foundations for a further deepening and qualitative improvement of mutual cooperation in the spheres of culture, education, science, film, mass communications media, youth, and sports. [Text] [Bratislava PRAVDA in Slovak 27 Feb 85 p 2 AU]

FIRE DAMAGES ECONOMY--Last year there were 1,906 fires in Slovakia, which caused direct damages to the tune of Kcs 54.4 million; 62 persons lost their lives and 143 were injured. Compared with 1983, the number of fires decreased by 32, but the damages increased by Kcs 4.5 million. The situation in all of CSSR is similar: According to preliminary figures there were 8,454 fires; damages amounted to Kcs 287 million (that is, almost Kcs 96 million more than in 1983). These data were announced at the press conference held by the Main Administration of Fire Protection attached to the Slovak Ministry of Interior together with the Slovak Fire Protection Union on 26 February in Bratislava. [Summary] [Bratislava PRAVDA in Slovak 27 Feb 85 p 2 AU]

DEVELOPING COUNTRIES' JOURNALISTS' TRAINING--The International Organization of Journalists in Prague, which bears the name of Julius Fucik, on 18 February started another course for journalists from the developing countries. The course is being attended by editors of press agencies, dailies, radios, and television from Afghanistan, Ethiopia, Ghana, India, Nigeria, and Zambia. [Text] [Prague RUDE PRAVO in Czech 19 Feb 85 p 2 AU]

ANTITANK MISSILES--Malyutka-Drobcek--That is what they call this man-portable antitank system [Slovak: protitankovy komplet]. It contains electronic components and is one of the most up-to-date firing systems in our army. Members of the Slovak National Uprising artillery unit, on their first live firing exercise, also found out that it is not an easy thing to master the use of anti-tank guided missiles. They acquired their first experience of the equipment on simulators, by means of which they learned how to direct the guided missiles at stationary, moving, and concealed targets. After 1,200 electronic [simulated] rounds, they got the feel of the real guided missile. Today it is the turn on firing practice of First Lieutenant Jan (Sulej)'s battery. They will be taking their NCO exams next week, and after that they will act as senior operators and commanders of companies of artillery units in the Czechoslovak People's Army. [No video available] [Text] [Prague Television Service in Czech and Slovak 1830 GMT 1 Mar 85 LD]

GERMAN DEMOCRATIC REPUBLIC

## PROBLEMS ENCOUNTERED IN DIGITAL COMMUNICATIONS EQUIPMENT

East Berlin MILITARTECHNIK in German No 1, 1985 (signed to press 9 Nov 84)  
pp 39-41

[Article by Col Dr W. Hanisch, engineer, and Col Dr L. Voigt, engineer:  
"Problems of the Introduction of Digital Communications Equipment in Military  
Communications Networks"]

[Text] A characteristic feature of our time is the growing demand for information in all areas of life. In particular, this is true in military affairs. An expression of this is the demand for an ever greater number of high-quality communications channels. But in attempting to meet this demand one very quickly encounters certain constraints which are primarily economic in nature--apart from the inherently limited character of the frequency spectrum in wireless transmission.

To resolve this problem it has long been the practice to make multiple use of the transmission paths (multiplex transmission). At the present time most multichannel transmission systems are constructed on a carrier-frequency basis. This process of frequency-divided transmission has been in use for decades in communications of all sorts. It has proven its efficiency and has at its disposal fully developed circuit engineering techniques available for the most varied applications. For this reason carrier-frequency links will continue for a long time to be a proven and reliable means of information transmission.

Despite all these positive features nevertheless for a long time efforts have been under way in the construction of new communications networks to replace analogue, frequency-staggered communications transmission by a system of digital time-divided transmission. This transition is expected generally to be a progressive step both with regard to the quality of communications links and also with regard to the more intensive use of existing communications channels.

### 1. What Are the Advantages of Digital Communications Transmission?

Especially for military communications, digital technique yields a number of advantages of which the following should be particularly emphasized:

i. The digitally switching communications techniques may be more easily and comprehensively assembled into highly integrated circuits than is the case at present when using analog technique. Digital methods permit an economically favorable use of microelectronic circuits. This results in smaller housing dimensions, lower weight and a reduced power consumption--and these are features which are essentially desirable for mobile communications facilities and which have an advantageous effect upon the configuration of flexible communications networks.

ii. Integrated circuits increase the reliability of communications equipment and lower the cost of maintenance. At the same time such integrated circuits make possible equipment having a high degree of automation which radically simplifies the installation and operation of such equipment. These characteristics relieve the communications troops of routine activities and help to establish communications links punctually and rapidly. In particular, they eliminate subjective human errors.

iii. Digital transmission procedures are relatively insensitive to attenuation oscillations so that unavoidable variations in parameters of the transmission path within wide limits have no significant effect upon the quality of information transmission. Moreover, as compared with frequency-staggered transmission they permit a substantially greater number of transit through-connections.

The signals are boosted over a transmission line with the aid of repeaters. Distortions arising from the transmission system or from interference from the outside are eliminated. As a result, thanks to the system's use of the repeaters less severe transmission-engineering requirements need be imposed on the electrical parameters of a transmission line. The high level of automation (that is, the fact that there is no longer any need for a detailed preliminary survey of the connection) and the essentially better behavior of the system with regard to interference from outside are especially advantageous for use in military communications.

iv. Digital signals contain the information in coded form. In consequence, direct wiretapping, even with the insertion of filters and other traditional types of circuitry, is no longer possible. The digital form of the information favors group encoding which renders more difficult undesired diversion of information.

v. A digital communications system consisting of digital transmission paths and digital switching located at the network nodes makes possible the construction of service-integrated networks in which all types of communications traffic (e.g., telephone, teletype, telefax and data transmission) are handled in basically the same way. This is advantageous both with respect to the efficiency of an existing network and also with respect to the characteristics of the transmission path. With a uniform digital communications network there are better opportunities for the use of wireless transmission paths. Under present conditions it is possible to make use of optical communications systems only on the basis of digital signals. As a result of the digital form of the signals modern, previously unknown methods of communications transmission become possible which are especially useful in military networks.

However, these characteristics are not exclusively associated with digital technique. They are also increasingly to be encountered in analog technique. For example, highly integrated circuits or the automation of equipment operation. And besides, attention must be drawn to some problems which a digital communications system entails. We shall describe the most important of these in the following paragraphs.

## 2. Problems of Digital Communications Transmission

Analog and digital communications systems are not compatible but must operate simultaneously and separately for fairly long periods of time. Every analog signal must be processed for the digital network. And on the other hand the digital signal must always be retransformed into an analog signal before it can be evaluated by an analog receiver. Thus, for example, the speech information which is input to a telephone terminal requires analog-to-digital conversion before it can be processed and then transmitted within the digital transmission system. Since this conversion must be carried out both at the information source and at the information sink it is always necessary to employ two converters.

If for any reason there is a transition from the digital network into the analog network a corresponding signal conversion must be carried out. Thus, for example, if carrier-frequency systems are to cooperate with digital transmission systems it is necessary to create TF-group-Codex\* which carry out the analog-to-digital conversion of the frequency-carrier group spectrum in such a way that it can be transmitted by means of digital multiplexers. For the connection of carrier-frequency systems to digital links one especially requires transmultiplexers which are capable of completely resolving the carrier-frequency group.

The communications transmission is rendered more expensive as a result of the need to add these components to the hitherto conventional signal path. Such components can be a source of undesired effects or even of breakdowns and thus under some circumstances can cancel out the advantages of digital transmission.

There is another problem: the integrated circuits are very sensitive to surges both in the supply voltages and also in the signals. If one considers the effects of the electromagnetic pulse then it is apparent that extensive precautions are required if the requisite degree of protection is to be achieved for these circuits.

Moreover, the level of automation achievable by digital technique, which simplifies the operation of equipment, must be largely purchased at the cost of more complicated circuitry. This shifts the training requirements from the operators to the repair people. For maintenance and repair it is necessary to embark upon entirely new routes. Although digital circuitry permits new and effective methods, such as those which appear in modern diagnostic procedures, there is an increase in the demands imposed upon the knowledge and competence of shop personnel. Nor should one forget the costs incurred in equipping laboratories and purchasing instrumentation.

From what has been said it should already be clear that the use of digital technique in communications must be carried out logically and prudently. The first consideration should be the increased efficiency which may be achieved thanks to modern electronics--especially microelectronics. If besides one is to take into account the special nature of military communications and its basic requirements then the use of digital communications technique in the military area becomes not merely a matter of judging particular needs but is a law of technological and economic imperatives.

### 3. How Can the Digital Signal Be Produced?

Out of the multitude of details relating to the preparation, transmission, switching and reacquisition of signals we shall here select and explain those having to do with formation of the digital signals. Already at this point basic decisions are necessary because there is no such thing as "the" digital transmission process.

There are several optional processes:

- i. pulse code modulation (PCM),
- ii. difference pulse code modulation (DPCM) and
- iii. delta modulation (DM),

with their specific peculiarities and modifications arising in military communications applications.

In pulse code modulation (Figure 1) [Figure not reproduced] the analog signal is sampled at constant time intervals. The resulting sample value is quantized and encoded.\*\* The PCM signal consists of code words which are assigned, in accordance with a pulse code, to the different levels of quantization (sample values). Such a PCM signal can be intermeshed with other PCM signals and transmitted as a PCM time-multiplex signal.

In delta modulation the difference between the momentary value of the analog signal and a comparison signal is determined (Figure 2) [Figure not reproduced]. According as this difference is positive or negative a binary signal is formed. In order for the difference to represent the analog quantity as accurately as possible it is necessary for this process to involve a higher sampling frequency than is the case in PCM, but this is compensated for by the fact that a smaller transmission frequency band is required than that required by PCM.

Difference pulse code modulation combines features of the two just-mentioned modulation processes. As in DM a difference is formed but the value of the difference thus derived is, however, transmitted in a code word, as in PCM. As a result of this combination procedure the sampling frequency of 8 kHz for an analog signal is sufficient.

Amongst others, the following considerations serve to decide which modulation process should be used:

i. Nature of the signal to be transmitted. If speech is transmitted then because of the relatively small change in amplitude of neighboring momentary values of the speech signal it suffices to use delta modulation. However, if one is dealing with picture transmission with its abrupt changes in signal then the use of difference pulse code modulation is indicated since this, as compared with pulse code modulation, requires a lower transmission velocity and hence also a smaller band width.

ii. Nature of the Codec and its location in the network. Quite generally Codecs are simpler and cheaper for DM and DPCM than for PCM processes. However, if the Codec is to be housed at the site of the transmitting devices then the PCM Codec is advisable because it is simpler to design as group equipment. The two other Codec types are more appropriate in the terminal devices.

iii. The intended level of integration of the digital network. The construction of such a network is not accomplished all at once and it does not immediately encompass all domains and all varieties of traffic. Such a network can be constructed in stages. A possible variant of this is briefly sketched in Figure 3 as an example:

In the first stage only the segments for multichannel transmission are digitalized. The Codecs are housed in the channel-forming devices. Both the subscriber network and the through-connection switching are analog systems.

In the second stage the analog-digital converters are introduced in the remote-side outputs of the terminal exchanges.

The through-connection exchanges are digital equipment. From this point on the entire communication transmission takes place digitally between the network nodes without intermediate conversion into analog forms.

In the third stage the terminal exchanges are also converted into digital exchanges. Only the subscriber network continues to be operated in analog fashion.

In the last stage the signal is transmitted from subscriber to subscriber entirely in digital form because now the Codec is located in the subscriber terminal. It is only in this form that the intended increased network efficiency can be fully achieved. If that terminal state is only reached at a later point in time then nevertheless at every intermediate step it should not be lost sight of, to avoid dismantling routes which will later be found useful. According to current opinion, delta modulation appears to be the most suitable procedure for speech transmission in military applications.

With the posing of such questions one has by no means exhausted the decision spectrum involved in the introduction of digital communications transmission and switching in military networks.

#### 4. What Comes Next?

There are further problems which arise from the need to cooperate with the facilities of civilian communications. Here, to the same extent as in the case of the analog communications network, it is a matter of obtaining well-defined standardized interface conditions. These must include, e.g., transmission velocities, line codes, control commands (protocols) and questions relating to the synchronization of such networks.

There must also be mutual accommodation of the system principles governing digital multiplex equipment, in order to combine several digital signals in channel compression and in order to be able to further intermesh these signals timewise.

In civilian communications an important role is played by the question of selecting a basic strategy of digitalizing. Here, it is a matter of proceeding in accord with either a substitution strategy (step-by-step strategy) or a superposition strategy (overlay strategy). In substitution the various network levels are digitalized step by step one after the other. Basically, one can start in any network level. If one starts in the local network level then digital islands arise in an analog environment. If one follows the superposition strategy then a digital network is erected by way of supplement to the existing analog network. As the digital network grows the analog network loses importance and can finally be shut down. The decision depends largely upon the already-existing communications networks and upon the demands imposed upon the new network and also upon the tempo of the construction of that network. Certainly the relevant conditions are different in different telecommunications administrations.

For communications networks employed militarily the above-listed variants with their four stages of digitalization could be taken as typical. However, depending upon the concrete conditions the boundaries between the individual stages need not be so sharply defined. Especially the transition from the third to the fourth stage does not appear to be very complicated in engineering terms. But if one just considers the number of devices involved in the changeover one recognizes that it is precisely this step which is probably the most expensive, because it must encompass every possible subscriber. Finally, it is a question of creating that uniform digital terminal which yields uniform conditions of access to the digital communications network. For military digital networks one may also consider the route via digital islands; in other words there must also be a guarantee under the military aspect of that already-mentioned adaptability requirement in the shape of carrier-frequency group-Codex or transmultiplexers.

The comprehensive introduction of digital transmission segments in military communications is imminent. Therefore engineering principles are becoming practically important which differ fundamentally from those which have been employed up to the present. This imposes high demands both upon the design work in the planning of militarily employed digital communications networks and also upon the knowledge and competence of those who must guarantee communications links by digital communications means. Therefore, more than in any



other context, no time should be lost before creating the required educational preliminaries.

Above all it appears to be necessary to renovate and deepen knowledge of the nature and principles of digital procedures, of analog-digital conversion, of the principles of digital transmission and switching technology and also of network problems generally. In so doing, the foreground should be occupied by fundamentals and by the principles of action and only secondarily should attention be given to the construction of physical equipment. The measurement of digital quantities and the use of diagnostic technique also merit special attention.

In a field such as this which is in the process of development there is necessarily a lack of summary literature in the sense of a standard reference work. Therefore it is necessary to go to the relevant publications of the specialized journals as a source of this new knowledge.

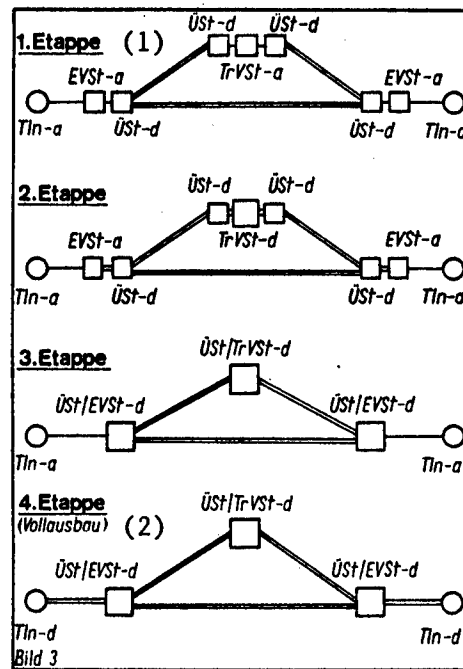

Fig. 3. Possible variants of the construction stages of a digital communications network: — analog transmission path (a); = digital transmission path (d); Tln--subscriber; EVSt--terminal exchange location; TrVSt--transit exchange location; ÜSt--transfer location.

Key: 1. Stage 2. (Complete construction)

FOOTNOTES

\* Codec = encoding-decoding device; a device for analog-digital conversion in the transmission direction and digital-analog conversion in the receiving direction.

**\*\* Any digitalizing (analog-digital conversion) consists of three processes:**

1. Sampling = regular sample extraction of an analog quantity. This provides pulse-shaped sample values which reflect the original function time-discretely.

2. Quantization (amplitude quantizing) = value-discrete association of sample values (signal samples) with specific value levels (value intervals) which are limited in their number. Every sample value is characterized by the value level in which it lies.

3. Encoding = assignment of binary code words to the individual quantizing levels (according to mathematical rules).

8008

CSO: 2300/287

TRADE UNION COUNCIL SECRETARY COMMENTS ON REFORM

Budapest MAGYAR NEMZET in Hungarian 17 Jan 85 p 5

[Interview with SZOT Secretary, Laszlo Bukta: "Standard of Living and Work Discipline, SZOT Secretary About Reform at the Beginning of 1985" by Gabor Kapuvári; date and place not specified]

[Excerpt] On its fortieth anniversary, this proud birthday, the trade union is measuring the path it has followed up to now. Its experts are studying what it has done and what kinds of tasks are facing it in the future. But it is not a simple matter to answer the latter question. We are witnesses to constant changes in our economy. We are adapting to the world, to altered conditions, and to newly shaped and developed internal laws. In this constant change it is obvious that trade union activity is also being modified. How? Where do they have to? What are they thinking? What are they planning? How is their role changing in economic life, in the distribution of material benefits, the defense of their interests? We asked for answers to these questions and others from Dr Laszlo Bukta, secretary of the National Trade Union Council (SZOT).

[Answer] The period starting with the year 1985 must mean a new role, tasks and style of work for the trade unions. We need to carry out significant renovations in order to continue fulfilling successfully our interest representational and interest protection functions. The workers' expectations vis-a-vis the trade unions have grown in these recently more difficult times. In order to carry out our common plans we need to mediate the views and efforts of those who are living on wages and salaries. These plans are related to economic-political goals and to the substance of the national economic plans. The trade unions have participated in the preparation of the 1985 economic plan from the beginning. In representing the interests of the workers we influenced the work of the planning organs, and I am convinced that such goals and tasks have been put into the plan which the trade union and all of working society will feel are its own. We believe that the unity we hammered out in setting the goals and tasks can rise to a truly political level only by way of deeds. It is a basic task of the trade unions to promote this.

## Increased Earnings in Regular Working Time!

[Question] The coming year will face the country with more difficult tasks than those of 1984. It is obviously necessary to discover new reserves in order to fulfill this plan. But we have been saying this for some time. In your opinion where are the remaining reserves?

[Answer] We have to realize our goals despite continually serious--and for us unfavorable--developments in international economic conditions. This means that our only chance is to discover and mobilize the possibilities latent primarily in our domestic economy. I regard as such possibilities the following: technical development, improvement of quality processes, modernization of the product structure, and an increased productivity in live work. There are still huge reserves to be found in work organization and work discipline. Everyone can make changes in work discipline, improvements in organization are the task of the managers. We are convinced that the basis for the expected economic achievement is the development of the will to achieve, and the innovativeness and the creative desire of our workers, technicians and economic managers.

[Question] Up to now you have spoken only of production and work and you have not mentioned distribution...

[Answer] For us interest protection begins in production, we believe that in order to create a balance between "purchasing power and the commodity base" we have tasks to carry out in the more broadly interpreted area of "the commodity base." It would be of no use to raise requirements which were not grounded in the reality of economic achievement.

[Question] Since we have already spoken about achievement, let us speak now about earnings. What is your opinion of the various entrepreneurial forms, and in their wake of incomes that are being developed?

[Answer] In general, these help us to achieve our goals. Most of the problems are with the VGMK's [enterprise work associations] where most of the misunderstandings occur. The trade unions do not oppose the efficient operation of these associations. We regard their operation as useful if they contribute to and increase enterprise results. At the same time, it is our view that proportionally with achievements, workers' earning should grow primarily in regular working time. We need to assure their ability to earn the material benefits necessary for their real demands in the regular 8-hour working time.

The new earnings regulation offers a good opportunity for those who work more and better in regular working time to be better paid. If this is realized, we may expect that the demand for activity beyond the legal working hours will decrease. The trade unions support an increase in the remuneration of work

performed during regular working hours. We expect an increase in the distributable national income from the development of the economic management system and from more efficient work.

#### Interest Protection

[Question] All these things combined are parts of the so-called living standard policy. Two important features of the 1985 economic plan are to stop the decline in the investment ratio and in real wages. This is only a relative increase, but it is an important question whether--as a leading economist put it--the weight reduction regimen of the national economy is coming to an end? What do you think?

[Answer] The trade union, as we have mentioned, begins interest protection at the production level. We are dealing with this more nowadays in order that the national income may increase, and that there should be an increase in distributable goods. The decline in real wages must be stopped at the work places, the work benches, and the work desks. In knowledge of this, however, we agree with a coordinated rise in nominal earnings and the consumer price indexes. The trade unions have acknowledged the extent of the price indexes since these serve to reduce unjustified supports and to realize actual and internationally acceptable outlays and profits. We regard the strengthening of price discipline, the intensification of social and official price control as very important.

#### Responsibility Belongs to Every Voter

[Question] In everyday economic reform, the "role assignments" of enterprise management are reevaluated. New forms are being introduced and here the place of the trade union is also changing. We do not as yet have practical experiences, but obviously basic plans and the well-considered thinking preceded the decisions. In the inventory system for the modernization of economic management, what kind of place is held by the new enterprise management forms?

[Answer] The introduction of new enterprise leadership forms is also of outstanding importance in the trade union's inventory of means. In working out and executing a great share of the decentralization measures of the property disposal rights, the trade unions have undertaken an effective initiatory and organizing role. We regard as our own the new enterprise management forms and we too are responsible that they should function as designed and that they should fill economic interests and property entitlements with real substance. The trade unions wish to promote the operation of the bodies. We must achieve for the trade unions a role as effective partners of management. Let us take as an example the enterprises that are guided by general meetings. Here the representatives of the trade union also vote for some kind of proposal. If it

does not turn out good and fails, then every voter "had a hand in it." But the responsibility of the trade union office holder is dual, because he is not only materially responsible like everyone else, but he must also render account to his voters on how he represented their interests.

[Question] All that we have been talking about is nowadays "in the air." People are talking about these things--wages and prices, enterprise successes and failures, GMK's [Work Associations], and new managing directors. What can you add to this? What is evident in the reports of the subbranch trade unions and the area organs? What kind of atmosphere is there in the work place, what are the workers talking of?

[Answer] The workers are expecting a general improvement in 1985. They expect the trade unions to continue their work in the field of wage and social policies. In general, it may be said that the work place collectives are expecting that with the improving economic and enterprise results their own living conditions will also develop more favorably. But they regard it as indispensable to higher level work--and this is very important--that there be an improvement in the shop conditions. They are expecting greater activity from the economic managers and from the trade unions in activity promoting production. It is the opinion of the workers that in the future the enterprise trade unions must find more boldly and concretely those work organizational, material supply and cooperation weaknesses which frequently and strikingly prevent successful production and enterprise management. We know the view of the workers. Not only in general terms but also its stratification. Therefore, we can successfully represent the sub-classes of workers if we conduct a differentiated sub-class policy and are well acquainted with the efforts of the various groups in the trade union membership. The trade unions are counting on the workers, peasants, managers, and subordiantes to hold their ground. We are devoting special attention to activating the sedentary workers who are of growing importance. We represent their characteristic and rightful interests and their demand for higher social and material recognition. We know, and we hope to help society understand, that they are also contributors among others to our successes.

6691

CSO: 2500/243

ROLE OF RELIGION IN SOCIETY

Budapest KRITIKA in Hungarian Jan 85 pp 4-5

[Article by Miklos Tomka: "The Role of Religion in Our Society"]

[Text] It happened years ago. I was talking with a French merchant. For him Eastern Europe meant business, experiences and stories to tell at home. For a long time he had been commuting between Leipzig and Sofia, Moscow and Budapest. His experiences went beyond the Zwinger and Ermitage and familiarity with national cuisine. While we were speaking of human destinies and cultural changes he suddenly interrupted me. "Do you know," he said about a distant large city, "one thing has not changed. For 20 years I saw only old people in the churches. They are still there. All of them. As though they had eternal life." I have not seen the French gentleman since then. He may have more work to do now, and perhaps he has new sights to look at. For example, those certain churches where old people seem to grow younger... and appear to have even increased in numbers...?<sup>1</sup>

Religious faith in developed socialism? I don't know what could better show that socialism is "developed." Perhaps the number of cases of building socialism, or perhaps the rate of development? However we look at it, religion is alive everywhere in Eastern Europe--and not only as a survival from the past but on the soil of new conditions, in new forms, capable of renewal, present in the new generations. But it is worthwhile to look more closely: in the field of religion there are two diametrically opposed processes. The old, traditional religion is disintegrating and dying out. The number of its followers and their social role is declining. At the same time interest in religion is increasing. New religious communities and views are acquiring social significance. Religion is present in our society.

This duality is not only characteristic of Hungary or of the socialist countries but also of the middle class and developed half of the world. This duality has not only misled us but also practically the whole of social science. First the signs of religious disintegration and secularization appeared, and on the basis of this both bourgeois and Marxist sociology came to the conclusion that religion is disappearing or that its importance is rapidly declining. Only later did it turn out that

the new religious music, the basic communities and the interest in theology were not merely a passing fad. In any event, the theory of the decline of religions had to be rewritten as the theory of religious change.

In Hungary both aspects of the change are well in evidence. The descending branch and the ascending branch. On one side:

--The relation of official and religious culture has been eliminated.

--To the end of the 1940's practically every child was baptized, every dead person was accorded a church burial, and marriage rites were performed in church. By 1970-1971, four-fifths of the baptisms and burials were held with church rites, and one-half of the marriages. Data for 1983 (it is true that these are limited by area and are only for Catholics) indicate a further decline of about 20 percent.

--At the end of the 1940's--according to various estimates--30 to 60 percent of the adult population attended Sunday mass. Today the ratio has declined to one-fourth. The ratio of persons calling themselves religious declined from 49.7 percent to 38.3 percent between 1972 and 1982.

--To the end of the 1970's it appeared that the declining number of religious people came increasingly from among the elderly, villagers, those with a low level of education and those not employed. From this it was concluded that the generational change, urbanization and the rise in the level of schooling, etc. would lead to a further decline in religion.

--The number of persons choosing a church mission and the number of priests declined. In the Catholic Church, for example, there were 3,583 priests in 1950, 2,582 monks and 8,956 nuns. The Hungarian state revoked in 1950 the right of monastic orders to operate (excepting only orders, with a limited number of members necessary for the operation of church high schools). The number of priests declined to 3,722 [sic] by 1960 and to 2,790 by 1980. Studies forecast a further decline of 25 to 30 percent by the year 2000.

Finally, a less spectacular fact: church orientation has weakened greatly even among the traditionally religious. As a consequence, the ratio is increasing of those who regard themselves and say they are religious, but do not maintain ties with any church. According to research in recent years, 79-82 percent of believers belong in this category. "I am religious in my own way," they say.

Thus this half of religious persons (more precisely, those who regard themselves as religious or had religious upbringing), a weakening of the church institution and perhaps a crisis in its life. But on the other hand:



--Hundreds of religious communities are being formed (4,000 to 5,000 according to some estimates) which carry out noteworthy instructional, cultural and social work. The religious commitment of the members and their religious zeal have also revived the life of traditional assemblies and church communities. "We regard these as revival movements of the kind which have frequently appeared in the history of the church," says Imre Miklos president of the State Church Office.

--A significant share of the religious people--including those who have newly discovered religion--in the small congregations and outside consist of young, better educated urbanites. The religious part of society is rejuvenated and culturally strengthened with these people.

--In a society struggling with a value system and want among the congregations [communities], interest increases in a religion where such problems do not exist. The greater than average number of children among religious families and the lower divorce rate bring respect. The high degree of personal helpfulness and social commitment makes one curious. What is the basis of this, and how did it come about? It is understandable, therefore, that there is an increasing demand for books, films and programs dealing with religion and religious studies.

--Some religious people--an increasing share--are making a great effort at acquiring a more spiritual outlook. (In the three large churches almost 1,000 persons are studying in this way.)

These facts do not contradict the end to the state church and a majority Christianity. On the basis of sound estimates we may estimate that as a result of the dual change the ratio of religious people in the coming years will be stabilized at about 30 percent of the total population and that one-half of two-thirds of these will be believers of strong conviction, existentially committed and conscious, with their own level of religious education. For this reason the religious orientation in life will by no means be the characteristic of people who are embittered or isolated from the world, but rather they will be an example influencing the whole population. It may be disputed to what extent our data are accurate or expressive. The fact is--and a fact that is borne in mind in political life every day--that "there are many believers in our country" (as Janos Kadar stated in 1975, and that Marxism and religion will continue to coexist for a long time (as put by Gyorgy Aczel in 1976). The religious example therefore must start apersonal and community self-examination. We see that religion is kept alive less by custom and tradition than by correspondence to the present social requirements. However, we still need to answer the question: What are the sources of this demand, what are the individual and social functions of religion?

G.W. Allport, the American psychologist who is well known in Hungary, differentiates between two kinds of religious attitudes: the "internal" and the "external." "External" religious attitude is a "refuge." It is

the escape of those who cannot find their place in life either through their own fault or otherwise. It is protection for the outcasts of society, the oppressed, the wretched, even if it is not a full solution. A protection both in the community of those with a common fate and in the strength of a personal faith. Marx, who himself took opium pills as a painkiller, speaks of an opium function. It is unclear, however, whether he was thinking of its stupefying effect or of symptomatic treatment. Of course an alternative is formulated, a changed world, the struggle against inhuman conditions. This is not a debatable matter. At most the question is what can be realized in this direction by a cripple whose degree of disability has been established and who becomes for society as a whole a pension number. Therefore, an individual may have need for treatment--of his symptoms if no other way exists. The new religious communities, the new values and goals make it possible to start anew: life and the world become rational again--and this is something!

Religion and the church are often a makeshift for society. At least three fourths of the world's leper colonies are maintained by churches. While in all certainty acceptance of this world's problems and flight into the other world did not initiate the work of Albert Schweitzer or Mother Theresa of Calcutta, countries which are unable to solve their own social problems are glad to accept all help. Especially if the costs involved are not accompanied by any profit. It is not accidental perhaps that there are in the hands of the church so many remote hospitals in the world or institutions treating debilitated children. Two decades ago Tamas Szecsko showed in one of his brilliant studies that religiousness increases following an economic crisis. We would put it this way: there is an increase in the number of those who are seeking refuge, all kinds of compensation and security in religion. We can, in fact, continue this line of thought. The same is true in times of war and natural catastrophes. Where there is no peace and where the accustomed security of the world has collapsed, churches are full. Can this relationship be turned around? Does this "external," security-offering, "refuge religion" come to an end if there is complete peace, if economic development is balanced, and if the exploitation of man by man is eliminated? There is no doubt that in a communist society the end to social alienation and to economic impoverishment makes all kinds of compensating mechanisms unnecessary. It is questionable, however, whether we can expect that science will abolish all disease in the world. And even if it could, would it be enough for the happiness of one whose beloved family member, friend, or child has died? It seems that shocks cannot be completely removed from the life of man. It is rather empty and dispassionate advice that these must be borne with a strong spirit. The problem is what might give strength to accept the trouble which has already occurred. It appears there will be tasks in the future, too, for "external" religion.

According to G.W. Allport and his school, the second type is "internal" religion. While the representatives of "external" religious attitude have regarded religion as a means and tried to use (exploit) it for the

solution of various kinds of problems, "internal" religious orientation is a line of direction, a value system, an ultimate goal. "External" religion is a search for security in existing religious communities, institutions, cultures, that is, adaptation without any particular independence. The "internal," on the other hand, is the realization of several basic goals amid increasingly changing social, economic and historical coordinates. Thus for "internal" religion the structural elements, the traditional institutional, community and cultural forms are of subordinate importance and may be changed according to current individual and social demands. "Internal" religion is not an escape from the world or the search for a hiding place but an active and creative participation in every change. Therefore, change does not weaken but strengthens it. "Internal" religion is not identical with a withdrawal from conscious or world outlook positions which are thought to be secure but is an ever new conceptualization of the meaning of individual and community existence. Finally, the believer in "internal" religion cannot postpone man's happiness to the other world after death, rather he rejects the mechanical division and confrontation between "this world" and the "other world." According to him, God's world can be created if we strive from birth until death and for the benefit of others, for the ending of all oppression and discrimination and the establishment of peace. In religious terms of expression this is to say that "God's world begins here on earth."

Religious psychology and religious sociology maintain that "external" religion characterizes in main the traditionally religious areas, where religion is a part of propriety and good manners. (This is familiar in Hungary, too. There are many places where they still say that "only church marriages are real," or that "a child must be baptized so that he will become a respectable man!")

But in Hungary this tradition is beginning to crumble. That religion is becoming rare into which man is simply born and which he wears as carefree as his native tongue or his nationality, hiding beyond its psychic or community walls of protection when misfortune occurs. Religion today is one of several possible world views. From some it evokes sympathy and from others antipathy, but is in no way the guarantee of a social career. It is still not excluded that someone is "religious" because this is the expectation which feels to be the strongest in his environment. But the more the social rewards of religiousness decrease and the more he requires an explanation why someone is religious the probability greatly increases that this kind of man is religious for reasons of personal decision and commitment, that is, he is "internally religious."

The essence of "inner" religiousness can be summarized briefly: One wants to surpass himself, exceed this limits, and he is sure that he will succeed in this. The same attitude can be found in many other noble efforts. This attitude places "internal" religion among the most valuable individual and group efforts. This attitude creates a kinship between religious and profane movements which seek to make man more

free and the world more human. Engels draws a parallel between early Christianity, the modern workers' movement and the modern socialist movements. It is true, he says, that Christianity wanted to realize social transformation not in this but the other world. But V. Lanternare, the Italian Marxist who is also well known in Hungary, showed in his world famous work ("Colonization and Religious Freedom Movements," Budapest, Kossuth 1972) how closely intertwined the religious and worldly elements were in the national liberation struggles. The theology of the Latin American revolution offers the Christian theory of protest and battle against exploitation and "structural violence." (And that it has not remained mere theory is proved not only by the priests who have joined the guerrillas or fallen in their ranks. Equally serious documentation is the fact that the Christian activists volunteer for the organization of cooperatives, the establishment and conduct of people's schools, and trade union work--although we well know that in Chile, Brazil and other countries they can pay for this with their lives.) The churches are also there in the fight against racial discrimination. Finally, it is also worthwhile to mention personal examples. Making the world more human may take place not only by way of structural reforms or revolution. In fact, these do not even have genuine importance in many cases. There are times when it is necessary to have human sympathy, support and love. It also makes the world better if someone devotes his life to others--like a doctor, an expert who devotes himself to the fight against backwardness like the above-mentioned Albert Schweitzer and Mother Theresa, or Cardinal Leger, who gave up the Canadian Laval bishopric when he went to Central Africa to care for lepers.

According to experiences thus far, however, the social, economic and political goals inspire enthusiasm only temporarily, and give meaning to a man's life only for a while. The "post-revolution generation" is looking for new ideals. The child of a parent who strove for well-being over a lifetime regards his living standard as natural. Great changes and great victories are frequently followed by disenchantment, a feeling that "this has not made us happier." Here is the greatest difference between religious and worldly goals, movements and struggles. It appears that religion succeeds in squaring the circle. It sets as its goal a final condition which cannot be realized--particularly in man's short life span. Thus the distant goal is set for once and forever. At the same time, in proportion to his individual effort man becomes balanced, peaceful and happy here and now. He has at least a little share in "perfection." The mystery of the matter is simple. The ("internally") religious man does not want to get, to acquire. It is not his goal to acquire equal or greater wealth, power, and rights. Although he rejects all exploitation and defrauding, as a community being he does not strive for the recognition of his community, for rank or influence. The ("internal") "trick" of religion is giving maximum satisfaction and service to the needs and requirements of others. Among his own possibilities everyone has a way of doing this. But human joy--the religious people maintain--makes life meaningful. For everyone individually and no less communally. This is a medicine which cannot bring nausea or come in an overdose. At most, it does not suit everyone's taste.

Like the historians and philosophers worry about how much truth there is in the beliefs and traditions of a religion. There is not much meaning to the pseudo-psychological question whether modern man can believe at all or whether religion can motivate over a whole lifetime. It is a fact that there are religious people. More than a few. One group, which is growing smaller, is "externally" religious out of habit or for escape. (This does not at all mean, however, that for this reason such a religion does not suit social requirements, or that it has no social function. Less scientifically, we could put it this way: "failing something better," but our society also has need for religiousness! At least if it is concerned for the fate of the elderly, the disabled and the lonely.)

Another group, increasing in size although still small in number, is religious because its members believe this is the best way to cope with the individual and social problems of our existence since this is what makes their life meaningful, and this is what gives a stronger prompting to community commitment. Undoubtedly for many this religion is a fantasy, a collection of utopias and illusions. It may be assumed there are some who regard this religion as a somewhat strange but real and attractive alternative. Lack of confidence in other alternatives belongs, in any event, among the sources of interest in religion. Someone may become religious who has been disappointed in attempts at solving social contradictions or other individual problems. Someone may be religious who sees this, among many possible attempts, as the one that is the most promising, creates the most confidence, and is the least discredited. This appears to be true of the religious interest and religiousness of young people. In this case religion is the driving force of social activity and creativity and the motor of zeal in the solving of common problems.

Over and above philosophical discussions, this undertaking of responsibility is the means by which it is possible to measure the social value of religion and believers and to which it is possible to link the politics of religious and nonreligious people. "It is easier to form an honorable, worldly alliance with the believer to deal with the joint tasks of socialism and humanity than with the apathetic person who strives for nothing and rejects any kind of moral measure," Gyorgy Aczel stated at last year's national conference for agitation, propaganda and educational policy. "We regard as the basis of our cooperation the moral principles by which they are guided," Imre Pozsagy added recently and then began to list these principles one by one: "love, patience, the requirements of mutual help; marriage, family life, respect for motherhood, the joy of having and rearing children; recognition of the value of work; rejection of selfishness and if necessary the undertaking of self-sacrifice." That is to say, everything is given for a unity in action. Or does it very gradually appear we are speaking of more? As though we were mutually recognizing not only one another's achievements. As though we were finally evaluating the man--the man who is committed by religious conviction or other reasons. From here it is only a small

step to hold in respect a basic world view that seems alien to us: as the source of social values and as the path to happiness for many people. And to show that this step is not impossible we need to refer to the analyses of Gramsci or the example of Italy and some Latin American countries. Where under different social and historical conditions religious people are also active in the party.

In a word, religion lives and is reborn in socialist society. There are two matters that keep it alive. On the one hand the weakness of our individual and social life from the shocks of private life to the still unsolved contradictions of socio-economic existence. (And it has been usual for such contradictions not only to be resolved but to be reborn.) For this reason many men--and society, too--need religion, but this does not cause religious renewal or upswing. Such developments have other sources. For many, perhaps for one-half or one-third of the population, religion is the strongest bearer of values. It is not influenced by economic crises, political blunders. And above all, this is what can create a harmony between the finite possibilities of man and the yearning for the infinite. Of course, all this appears rather theoretical. Most religious people do not conceive of it this way. But they represent something like this with their lives. That is why it becomes a model in the nonreligious part of society. On the plane of social practice all this, of course, does not cast doubt on the importance of discussions about the materialist and the idealist world view--only makes it certain that in this respect the historical processes are dialectical.

#### Footnote

1. Data in this study are based on sociological studies, see M. Tomka "Social Change--Religious Change" SOCIOLOGY, No 3, 1983.

6691

CSO: 2500/221

EFFORTS TO RAISE AGRICULTURAL FUND DETAILED

Warsaw PRZEGLAD KATOLICKI in Polish No 6, 10 Feb 85 p 8

[Article in PRZEGLAD KATOLICKI: "The Church On Its Agricultural Foundation"]

[Text] At a press conference held on January 24 at the Polish Episcopate's press office, a spokesman for the Agricultural Foundation's organizing committee, Slawomir Siwek, told reporters about the program of visits to Australia and Japan to be paid by Father Alojzy Orszulik, who represents the Episcopate in matters concerning the foundation, and Professor Andrzej Stelmachowski, who presides over the organizing committee.

These visits (from January 27 to Australia, and from February 13 to Japan), which were planned at the invitation of Church and secular institutions taking an interest in the foundation, were designed to inform the hosts on its purposes and organization and to win support for individual programs, especially during the initial period. It was untrue that, as was implied e.g. by ZYCIE WARSZAWY, as the foundation had failed to raise funds in Europe it had to look for money in more remote countries.

Dr Maria Stolzman, the committee secretary, described the specific proposals the organizing committee's delegation were taking with them to the two countries.

On its way back home, on February 25 and 26, the delegation is to stop in Brussels for talks with representatives of the EEC.

During the same conference, the foundation's spokesman also said that talks with the competent Government commission had been resumed after a four-month break. A meeting was held on January 22.

The Conference of Austrian Bishops assigned 1 million Schilling for the foundation in 1985. This decision was made in response to a special letter concerning help for private farming in Poland which the Polish Primate, Jozef Cardinal Glemp, sent last October to Cardinal Koenig.

CSO: 2020/84

POLAND

## BUJAK'S STAND ON ECONOMIC RESTRICTIONS CRITICIZED

Warsaw TRYBUNA LUDU in Polish 25 Feb 85 p 2

[Article by Krzysztof Krauss: "A Conspirator's New Worries"]

[Text] Radio Free Europe says that Mr Zbigniew Bujak [an underground Solidarity leader] has a new problem, and a big one. The problem is that the Americans have said they will no longer protest International Monetary Fund restoration of Poland's membership in this organization (of which, incidentally, our country was a cofounder). To be sure, Poland still must pay its own bills even with the lifting of this last barrier to resuming contacts with specialized UN agencies. By their statutes these agencies are to assist member countries in stabilizing their national currencies, to promote international financial cooperation and to remove all currency restrictions, thereby restoring multilateral trade all over the world.

Poland's application for renewing its member status does not mean Poland is expecting any "special treatment." But it is expecting, legitimately, that its presence in the IMF and the World Bank, as well as in GATT and other such international groups will help Poland to normalize its economic links with foreign countries on the basis of partnership, equal benefits, and respect of sovereignty.

Americans and their allies have become increasingly aware of achieving little by keeping the restrictions in force. Poland has already lifted itself high above the bottom line, with some help from other socialist countries, but mainly by its own efforts.

Naturally, due to U.S. restrictions, Poland suffered losses, estimated at \$15 billion. The process of building down structural tensions and limitations, especially in foreign trade, is taking more time than it might have otherwise. Living standards in Poland are several points below the level they might be under other "external circumstances." Yet it is also true that Poland is no longer receding but moving forward, though not without difficulties, and is resolving problems which had mounted for many years before. The only permanent effect of the West's policy of restrictions has been the strengthening of Poland's greater integration into the socialist Comecon economies, guaranteeing economic security and sensible use of national resources and ultimately Poland's long-term national interests.



But the "underground" finds it hard to accept that detriments to Poland's position in the world economy now belong to the past. So, while not openly protesting Reagan's decision to withdraw his veto ("It's hard to imagine Solidarity saying it doesn't want Polish IMF membership," we have been told by RFE), those in the underground are trying to open the eyes of Americans who are "too soft." RFE emphasizes that in letters Bujak personally has sent to some "union agencies at home and abroad," Solidarity demands that the IMF should demand fulfillment by Poland of a number of political and economic conditions in return for membership and credits. What conditions?

Apart from reactivating trade unions in the Lech Walesa tradition, the state should be barred from managing the national economy. This should be brought about by creating "socialized enterprises." But today, it has apparently been recognized, this would sound like too lame a demand. There is no need to be ambiguous any more, for this only confuses people. "The 1981 concept of reform," say underground activists on the air at RFE, "should now be supplemented with precondition that legislative guarantees must be given for equality before the law and for equal treatment of all sectors of the economy, including private, local, cooperative and public."

But even this might appear to be too modest a demand. For instance, this could be interpreted as guaranteeing conditions for development of private crafts shops, small-scale industries, and private farms, all of which not only have legislative guarantees, but are actually practised in Poland. This is not the point. The point of the ploy is to guarantee free movement for private foreign capitalists in Poland, to guarantee "the right to create joint-stock companies with mixed [Polish and foreign] capital, to develop a system of inducements for private capital holders to invest their money, the right to get part of their profits abroad." Since not everyone is enthusiastic about the prospect of selling out Poland to supranational corporations, the authors of the RFE call condescend to remark that, "It would be necessary to furnish legislation authorizing Polish citizens to create private firms and companies," thus avoiding what happened in the interwar period [of 1918-39].

What for? Among other things, in order to make room for a "healthy" kind of enterprise, based on private ownership, not only in manufacturing but in all areas of industrial production. For instance, say "unionists" in the entourage of Mr Bujak, "besides state-run financial institutions, there must be room for private banks, cooperatives (aren't they nice, those unionists, in not intending to liquidate the cooperative movement right away--TL note), special funds, foundations and insurance companies, etc."

The snag, as Mr Bujak and the remaining authors of this text at long last notice, is that "we don't know to what extent the IMF will listen to us." This insecurity threads throughout this lengthy text the RFE beamed out. Perhaps even our "underground" is finding it increasingly difficult to live in a world of delusion and wishful thinking.

It so happens that even those most implacably sticking to their intransigence must sooner or later view the reality around them the way it is. This means

that the wheel of history cannot be made to run backwards, and that countries of different political and social systems have to cooperate economically even though one might not be particularly enthusiastic about the "Reds" and want the situation to be very much different from what it is.

The world is too small, and national economies too dependent on one another, for this fact to be ignored. The sooner a sober view takes over, the better the world will be. Remarkably enough, at long last even the U.S. administration is beginning to comprehend this, to the frustration and disenchantment of certain people in Poland who are self-styled champions of a very peculiar brand of "national interest."

CSO: 2020/86

27 March 1985

POLAND

## POLITICAL WEEKLIES VOICE SHARP DISAGREEMENT

## Rem's Distortions

Warsaw RZECZYWISTOSC in Polish No 6, 10 Feb 85 p 5

[Article by the Editors: "Rem's Swindle"]

[Excerpts] This journal's unaggressive disposition was submitted to an excruciating test owing to Jan Rem's recent perfidious action. In the weekly TU I TERAZ of 30 January 1985, Rem published an essay called "Echoes of Stefan Bratkowski" which unquestionably is the peak of political fraudulence. The piece is rife with distortions, quotations taken out of context, straightforward slander and liverish attacks. One funny thing about the story is that although TU I TERAZ appeared on the Warsaw newsstands as usual on Tuesday morning, 29 January, ZYCIE WARSZAWY and RZECZPOSPOLITA reprinted the Rem piece in full precisely on that same Tuesday. They must have received a copy of TU I TERAZ the day before.

Since we are making serious charges against Jan Rem, we have decided to reprint the essays of Jan Rem and Andrezej Chmura in full for readers to see for themselves.

## Mechanisms

A friend of mine, who is know both for his unbridled frankness and his acute mind, says that, as a society, we would get an excellent deal if we could get various greedy yet incompetent decisionmakers to enjoy all the things of the good life under one condition--namely that they just do nothing. At least in the area of public matters.

This statement which is also a demand, is undoubtedly abnormal when cast against a society-wide backdrop, yet it seems enticing in some cases, when you ponder possible benefits and costs. It could be treated as a step toward economic stabilization were it not for the multiplicity of mechanisms which set off only ill-designed actions, and, thereby, make it really difficult to anticipate just who should be barred from the possibility of undertaking such actions.

Such hostile activity may be caused by a lack of the necessary knowledge, competence or imagination, or by crudely pushed vested interests etc. But then there are cases which are really difficult to explain in terms of any logic at all.

... Panel radiators burst like soap bubbles. Usually they crack at the joints. The surging gush of seething water may not only harm the apartment in which it bursts but also the entire building. Panel radiators have become synonymous with technical defect. If you have such a radiator at home you have as much bad luck as when your walls freeze through or get soaked with water, or when your Lentex-type floor covering starts to rot....

... It was found that serious violations of social justice principles and legal provisions were committed in planning these gardens, dividing them into individual plots and allocating them to users.... Cases of failure to perform control duties were demonstrated, while some people were proved to have taken advantage of their posts to draw personal benefits....

... The driver of a mail van, who caused a head-on collision between his car and another vehicle, had 0.21 percent of alcohol in his blood. There were Zl 18 million, apart from two equally drunk escorting guards, inside the damaged van....

The above news reports which have appeared in recent weeks disclose events of different scales of damage and with differing intentions on the part of their perpetrators, but they are only possible because of mechanisms the "driving force" of which are opportunism, passivity and powerlessness which overwhelms those present when they are facing the overriding power of all evil.

After all, a lot of people must have known that a great deal of state-owned money was in the hands of totally drunken people. Their fierce determination to knock themselves out shows they must have worked as "fruitfully" before. Whatever their cargo on any particular trip, sooner or later they were bound to have a crash. And yet....

That shady deal with those garden plots took place in Torun. Before it, there was the scandal about the granting of apartments in Walbrzych. The practice of taking financial benefits by using opportunities that go together with high posts is abominable. But what is really disastrous is the harm this does if it goes on right in front of the eyes of society. The consequence is bound to be an appalling apathy. No wonder, then, that those guilty of the glaring irregularities uncovered by a worker-peasant commission at the Plock Health Center failed to comprehend what all the fuss was about. They regarded the auditors as yet another nuisance that had to be endured.

The radiators mentioned in this note should be regarded as something of a symbol. The truth is that in the Lodz housing estate of Retkinia they began to burst as far back as 1976. Not only there, incidentally. And, it was not just radiators alone among newly supplied building materials that proved to be ripe for scrapping.

In my private collection I have a pile of programs with ideas for improving quality, efficiency and other elaborate arguments that are utterly at odds with every day experience. These have been churned out for years now, along with components and products which are known to give their users more trouble than satisfaction. It is impossible to detect any rational motivation for this inexplicable kind of behavior. In this situation, my friend's suggestion just might turn out to be the best thing to do.

A.Ch.

Why is Rem's trick a swindle? His first quotation is correct, from the words "We [as a society] would get" through to "public matters." However, he deliberately and, let us admit it, cleverly omits [sic] Andrzej Chmura's definition "if we could get various greedy yet incompetent decisionmakers." Rem badly needs this omission (sic). Whereas Chmura means and writes solely about those who are both greedy and incompetent, Rem stretches the phrase "greedy yet incompetent" over (1) all communists ("Stefan Bratkowski often came forward with the opinion that all communists want is personal comfort and private gains, and not benefits for the general public"); (2) all decisionmakers ("Between the introduction and this conclusion, the journal [RZECZYWISTOSC] unfolds its argument for barring the current leaders from influencing the government"); (3) all authorities ("The next reason for denying all confidence to the authorities...," "This accusation RZECZYWISTOSC hurls at the authorities is totally misleading"); (4) the Cabinet without a single exception ("A.Ch. denounces the current economic policy, calls to sack the governors, and deprive them of any confidence [because] one particular type of radiator [which are fixed in some apartments] tends to 'crack at the joints.' I don't say this is untrue, but I doubt it is the government which makes these radiators"); (5) the top floor ("It seems that A.Ch. too hastily, too eagerly and too mindlessly launches his attack at the top floor"). But Chmura himself writes in his next paragraph, which Rem perversely passes over in silence, "This statement which is also a demand, is undoubtedly abnormal when cast against a society-wide background, yet it seems enticing in some cases, when you ponder possible benefits and costs. It could be treated as a step toward economic stabilization were it not for the multiplicity of mechanisms which set off only ill-designed actions, and, thereby, make it really difficult to anticipate just who should be barred from the possibility of undertaking such actions." It takes an extremely bigoted person to give so outrageously distorted an interpretation of what was actually written by A.Ch. Because Rem demonstrated his utter incompetence in interpreting the word "decisionmaker," let us point out to him that this word is derived from the Latin verb *decidere* (to decide) and denotes anyone who determines, decides, resolves a matter or passes a verdict on things entrusted to his care. So, a decisionmaker is not only the Cabinet member Jerzy Urban but also foreman Kowalski, manager Nowak, director Zamojski etc. Are there no "greedy yet incompetent" decisionmakers among them? Let us also point out that Andrzej Chmura's column is regularly placed in our journal's research-and-technology section, which is designed to further the cause of Polish design and technology, through exposing cases of the waste of Polish inventions due to mechanisms which block their industrial utilization, among other things. Could Rem, a very careful reader of RZECZYWISTOSC, have failed to notice this? Or, did he perhaps prefer not to notice?

Rem reaches the peak (let us not say explicitly of what) with this argument, "The article on 'Mechanisms' is concluded with an avowal that its author shares his 'friend's' opinion that the governors should be removed from the management of national affairs, because economic programs are allegedly not put into effect while defective work unaccountably flourishes." And, as a quotation [Rem writes], "In this situation, my friend's suggestion might just turn out to be the best thing to do." Didn't Rem do a clever job to be the best thing to do." Didn't Rem do a clever job taking this quotation from its context in order to insinuate that decisionmakers "should be removed from the management

of national affairs?" In Andrezej Chmura's column, the reference to a "friend's suggestion" is concluded with this, "In my private collection I have a pile of programs with ideas for improving quality, efficiency and other elaborate arguments that are utterly at odds with everyday experience. These have been churned out for years now, along with components and products which are known to give their users more trouble than satisfaction. It is impossible to detect any rational motivation for this kind of behavior. In this situation, my friend's suggestion might just turn out to be the best thing to do." Now, then, Mr Rem, you yourself say it is not the government that produces goods, and yet you charge Chmura and RZECZYWISTOSC with doing just this? Where exactly, we would like to know? Where did Chmura write about "the authorities' economic programs?"

Much more evidence could be found--even in Andrzej Chmura's short text--of Rem's peculiar technique. Readers can easily do this for themselves. Rem's method would probably be endorsed even by Radio Free Europe. Only a short time ago, this station launched similar accusations against our journal. The question that arises therefore, is, just what is it Rem wants to achieve?

His text fortunately contains visible clues. For quite some time now, "Remists" have been trying to create the feeling that RZECZYWISTOSC focuses mainly on "hunting for enemies within its own camp." Such a view was stubbornly propagated by some journals spiritually akin to Rem. He himself writes, "RZECZYWISTOSC hunts for and exposes both all signs of sympathy toward the enemy and opportunism even inside its own camp." The "Remists" are determined to create the impression that RZECZYWISTOSC is a journal which only sows discord and unrest, strikes at the cause of national reconciliation, and harms the state. This time, by insinuating that we attacked the government, the authorities and all decisionmakers Rem wants to set them all against this weekly. This is not the first ever doctoring of our texts. Fortunately, competent people do not base their thinking only on Jan Rem's analyses. When his actions failed to produce the desired effects, Jan Rem who, according to his own statement, also writes under the pseudonym Klakson, called in a fit of fury for people to "go to the RZECZYWISTOSC editorial office and beat up those who deserve it." Convinced of his omnipotence, Rem was sure that those who reprinted his text wouldn't consult the A.Ch. note before doing so. Indeed, he was right.

So invoking Article 31 of the press law--"At a request from a physical person, legal person, or other organization, the editor-in-chief of a given daily or journal is obliged to publish free of charge (1) a substantive and factual rectification of an untrue or inaccurate news report, (2) a substantive reply to a statement 'that may affect a personal reputation'"--herewith requests all editors-in-chief of journals which published Jan Rem's text entitled "Echoes of Stefan Bratkowski" to publish this reply within the period prescribed by the law.

The Editors

## Economic Inaccuracies

Warsaw TU I TERAZ in Polish No 8, 20 Feb 85 p 3

[Article by Jan Rem: "After the Thrashing"]

[Text] I challenged the article called "Mechanisms" published by the weekly RZECZYWISTOSC. My dismissal of that article was called "Echoes of Stefan Bratkowski." It was reprinted by the dailies RZECZYWISTOSC, ZOLNIERZ WOLNOSCI and ZYCIE WARSZAWY. Now RZECZYWISTOSC is claiming that this article was reprinted by mistake and only because of my backdoor influence. I disagree with RZECZYWISTOSC over the question of why it was that the editors of these journals reprinted my article.

The RZECZYWISTOSC weekly retaliated to my "Bratkowski" (whose echo is once again audible) with a text called "Rem's Swindle," written by the editors. This text is a medley of punches and defensive explanations. RZECZYWISTOSC defends itself by claiming that my insinuations that the journal was attacking the government, its mechanisms and programs, as well as methods of government are without foundation. By referring to pernicious mechanisms that govern our lives, making people powerless in the face of the overriding power of all evil, the editors meant--or so they claim--only internal relations which are now and again wrong in some factories.

By writing about worthless programs for economic recovery which are at odds with everyday experience, RZECZYWISTOSC was allegedly only criticizing some factory programs for the improvement of the quality of some concrete products. The editors are now claiming that when Andrzej Chmura said that decisionmakers were greedy, incompetent and lacking in imagination while crudely pushing their own vested interests, and that for this reason these people should be prevented from launching ill-designed actions, the author of "Mechanisms," meant some factory overseers, maybe even foremen.

In their "Mechanisms" the editors of RZECZYWISTOSC called for decisionmakers to be barred from power, i.e. from the possibility of making decisions, and in return they are to be enabled, quote, "to enjoy all the good things of life under just one condition--namely that they do nothing." Now it turns out the journal's editors meant all the good things of life--yes, for overseers and foremen, because these were the people RZECZYWISTOSC had had in mind right from the beginning.

True, RZECZYWISTOSC wrote about decisionmakers and not government ministers, about programs and not government programs, about inadequate mechanisms and not the economic reform now underway, about the barring of decisionmakers and not about forcing the government to resign. So, if the weekly now reconstrues its "Mechanisms" as a criticism for some inadequacies occurring from time to time in some worker groups, then this self-prostration should be hailed. But I hurry to reassure RZECZYWISTOSC: even if the criticism published in "Mechanisms" was a shot at the government, even if by decisionmakers were meant overseers or, in a dash of audacity, even foremen, then this would be no crime. In my "Echoes of Stefan Bratkowski" I argued only that criticisms, whoever they may be aimed at, must never be demagogical. I argued that it does not

immediately or directly follow from the fact that some radiators tend to crack at the joints that the government is not good at anything. Or the fact that one driver was drunk does not vindicate the political conclusion that decision-makers should be sent into retirement and the existing mechanisms deplored, as Mr Chmura suggested in his RZECZYWISTOSC article. Even less justified is the conclusion, from the fact that officials of some rank in two voivodships were dismissed or otherwise punished for irregularities, that violations of the law or of justice are tolerated in Poland, that people in high posts can quietly draw unwarranted material benefits, or that such things happen right under the noses of society, generating "an appalling apathy." The example RZECZYWISTOSC cites to prove this point points to something entirely opposite namely that evil and vested interests are not tolerated but punished and made good before the eyes of all society.

This kind of demogogy is unacceptable, even though the journal now claims by "high-ranking people" it meant factory overseers. The journal thereby implies that decisionmakers of the rank of factory foremen are entitled to give deputy voivods and city presidents the sack. For, if by decisionmakers the journal meant factory overseers and foremen, the charge that vested interests and violations of the law by high-ranking voivodship officials are tolerated is actually directed against overseers and foremen.

In the statement which is signed by the editors of RZECZYWISTOSC, my text is described as a swindle and a manipulation, because I did not quote all the paragraphs of "Mechanisms," making instead a synopsis of the ideas presented in the article, I did not interpret the term "decisionmakers" and "high-ranking people" as overseers and foremen, and failed to see that there were precisely the means Mr Chmura had in mind. The editors also imply I spoke out against the RZECZYWISTOSC demogogy on behalf of an entire group of Remists. This was, according to the editors, a conspiracy created to persuade the decisionmakers (and thus probably also factory overseers and foremen) that RZECZYWISTOSC was creating hatred and sowing confusion. I reply, then, thus: Whatever RZECZYWISTOSC may do is of such little public or political significance that there is no need to go to the length of founding a self-defense organization against this journal. Instead of smelling mafias and conspiracies everywhere, their zeal could be better used in editorial work, say to check whether the contention that inadequate mechanisms functioning in our life cause an all-embracing apathy, a mess, a the pursuit of vested interests and defective work is sufficiently justified and pertinent.

In its editorial, RZECZYWISTOSC says, "Rem's method would probably be endorsed even by Radio Free Europe. Only a short time ago, this station launched similar accusations against our journal. The question that arises therefore is, just what is it Rem wants to achieve?"

I have all but come to believe the contention by RZECZYWISTOSC that decision-makers are factory overseers and that the appalling apathy here actually refers to relations existing on one factory floor, when the editors suddenly sap my trust in their veracity again. Somehow, I find it difficult to believe the editors whose signatures are printed beneath "Rem's Swindle" when they say that this journal was attacked by [RFE Polish section boss Zdzislaw] Najder precisely



for writing that decisionmakers in Poland should be sent into retirement because apathy reigns in Poland, mechanisms of public life are inadequate and make society powerless in the face of the forces of all evil. Unless of course there is another Captain [Andrzej] Czechowicz at work out there in Munich, subverting Mr Najder's endeavors.

In answer to the question what did I want to achieve with my essay "Echoes of Stefan Bratkowski" let me say it was precisely what I did in fact achieve-- namely a renunciation by RZECZYWISTOSC of its demogogical, unsubstantiated criticism of mechanisms and methods of government in Poland. Naturally, it would be better if the journal defined its own stance with more self-criticism than it has until now, and without such shilly shallying.

CSO: 2020/76

27 March 1985

POLAND

## CZYREK ADDRESSES PRZEMYSL PARTY CONFERENCE

AU121222 Warsaw TRYBUNA LUDU in Polish 7 Mar 85 pp 1,2

[Anna Pawlowska report: "Between Resolutions and Life"]

[Excerpts] The 6 March report-back conference of the Przemysl Voivodship PZPR Committee in Przemysl was the first in the country. The talks, which were chaired by Voivodship Committee First Secretary Zenon Czech, were attended by Jozef Czyrek, PZPR Politburo member and Central Committee secretary; and also by Anna Kedzierska, minister of domestic trade and services.

At the end of the talks, Jozef Czyrek expressed his respect and recognition for the entire voivodship party organization. He wished that the eminent results of the accountability campaign be a good forecast for the Przemysl Committee at the 10th PZPR Congress. Referring to the slogan of the talks--"consistency in action"--he said that a great deal of consistency is very necessary during the period immediately prior to the congress.

The entire present campaign, including the report-back conferences, are not only a statutory requirement for our party, but in view of our tasks also possess a great deal of importance concerning politics, mobilization, and integration. On the basis of the results achieved, we may specify our aims and undertake concrete action.

This year and the period prior to the 10th PZPR Congress will not be an easy time. This is because of the weight of the tasks we are setting ourselves.

The basic task is to further strengthen our party, J. Czyrek said, and this goal is served by the present accountability campaign. This strengthening should also be encouraged by the preparations for the 10th Congress, which will establish new horizons of socialist transformations in accordance with the requirements of today.

J. Czyrek spoke about the leadership's current work. He also discussed the problems connected with the Sejm election campaign, including its international repercussions.

A great task is also to tidy up the economic front. The price rises, with all their faults, have encouraged society's economic education. They should also

provide government elements with many conclusions for the future. Most of all, however, we should speak less about economic reserves, and mobilize them in practice much more consistently. The still unconquered effects of the moral crisis, which was society's loss, are making this difficult. That is why problems of human awareness and attitudes cannot disappear from the entire party's field of vision and sphere of influence.

CSO: 2600/694

POLAND

INFORMATION USED TO ATTACK TOKARCZUK EXPENDED

Warsaw RZECZPOSPOLITA in Polish 28 Feb 85 p 4

[Article in RZECZPOSPOLITA: "Sejm Chancellery On Bishop Tokarczuk"]

[Text] On February 27, NOWINY, a daily appearing in Rzeszow, published an article entitled "Sejm Chancellery Replies." The article read thus:

The Sejm Chancellery has recently received many letters and petitions mainly from south-eastern parts of the country. The authors of these letters and petitions asked the Sejm for an explanation of the accusations which defendant Grzegorz Piotrowski laid against Bishop Ignacy Tokarczuk during the Torun trial.

In this connection, the Letters and Complaints Office of the Sejm Chancellery kindly requests the editor to public the following explanation.

The findings of the Main Commission for the Investigation of Nazi Crimes, the Prosecutor's Office, the Ministry of Justice, the Ministry of Internal Affairs and the Ministry of Foreign Affairs all indicate that defendant Grzegorz Piotrowski based his accusations mainly on information about Bishop Ignacy Tokarczuk's collaboration with the Gestapo published by SETTE GIORNI, issue 20, of November 12, 1983.

It has been found that SETTE GIORNI is a magazine appearing in Sicily with a nation-wide circulation of several thousand copies. Thus it could have been brought to Poland. It is neither subscribed to nor ordered, however, by Polish official institutions.

The magazine published photocopies of three documents which, it said, had come from Radio Free Europe's archives.

According to these documents, in December 1943, Father Ignacy Tokarczuk agreed to collaborate with the Gestapo and gave them the names of nine inhabitants of the Zlotniki parish who were cooperating with Soviet partisans. As a result, on February 24, 1944, seven people from that group were arrested and murdered. Documents which the Main Commission for the Investigation of Nazi Crimes obtained from the Cracow Metropolitan Curia confirmed that many assaults and murders of Poles inhabiting the former Lvov diocese had taken place between July 1943 and March 1944.

According to these documents ten Poles from Zlotniki were killed and many parishes, including the Zlotniki parish, were abandoned by their priests during the period in question. These facts were described in the Bishop of Lvov Boleslaw Twardowski's letter of March 8, 1944, to the Cracow metropolitan Fr. Adam Sapiecha.

The Ministry of Internal Affairs has also received letters on this subject. Their authors wrote that the vicar of the Zlotniki parish, Ignacy Tokarczuk, left his parish in mid-1944, that in 1945 he appeared in the Katowice diocese and that in the first months of 1944, the Gestapo shot Jan Gandurski, Wlodzimierz Skretkowicz, Kazimierz Moskwa, Brzozowski, Ciecwiór, Jan Paluch and Jan Gandurski's son in Zlotniki (now in the Soviet Union). The information about Bishop Ignacy Tokarczuk published by SETTE GIORNI, in its issue 20, of November 12, 1983, was analyzed from the legal point of view. It was decided that it concerned offenses specified in the decree on the punishment of fascist and Nazi criminals guilty of murdering and torturing civilians and prisoners of war and of traitors to the Polish nation. This decree (with the exception of Article 1 pt. 1) has been revoked\*).

Thus the offense with which Bishop Tokarczuk was charged on the basis of documents published by SETTE GIORNI is now covered by the statute of limitations and hence he cannot be held responsible for it.

Therefore the prosecuting bodies did not institute legal proceedings against Bishop Tokarczuk. The Sejm has no authority to comment on this matter.

At the same time, the Letters and Complaints Office explains that Bishop Tokarczuk has had the opportunity to file a libel suit against SETTE GIORNI.

The Office has received no information that such steps have been taken.

The Office also believes that the fact that the Sejm Chancellery has received many identical petitions indicates that some Church representatives have organized a petition-sending campaign which certainly does not contribute to the recovery of socio-political stability and to national conciliation in Poland.

Some letters sent to the Sejm Chancellery also contained complaints about priests exerting various forms of pressure on the faithful to make them sign the petitions.

For instance Fr. Tarnowski, a parish priest from Pelkin, Przemysl voivodship, warned congregations on February 20 that the names of those people who refuse to sign the petition would be read out from the pulpit.

Fr. Lepak, the administrator of the Hurko parish near Przemysl talked people into signing the petition by stating that the names of those who did not sign would be read out from the pulpit and that they might be refused the sacraments.

Fr. Kielbowicz from the Wietlin parish, Przemysl voivodship, condemned those faithful who refused to sign the petition in his sermons and during pastoral visits and threatened that he would not allow their children to take their First Communion.

The above explanations are considered by the Letters and Complaints Office to be their reply to the letters and petitions sent to the Sejm Chancellery.

Signed,  
Director Gerard P. Pustowka

\*The decree was revoked in connection with the 20-year statute of limitations envisaged by Polish law with regard to crimes punishable by the death sentence.

The law of April 22, 1964, on suspending the statute of limitations introduced the provision that the statute would not apply to the crime specified in article 1 pt. 1 of the decree of August 31, 1944, i.e. the crime of taking part in the murder of civilians, the military or prisoners of war.

CSO: 2020/89

WORK ON CONSTITUTIONAL TRIBUNAL NEARS COMPLETION

Warsaw RZECZPOSPOLITA in Polish 28 Feb 85 p 1

[Article in RZECZPOSPOLITA: "Constitutional Tribunal Bill"]

[Text] At a joint meeting on February 28, the PZPR, ZSL and SD Sejm caucus presidiums discussed the bill on the Constitutional Tribunal. The meeting was jointly charied by Kazimierz Barcikowski, Boleslaw Struzek and Jan Fajecki.

It was recalled that the political and legal initiative of establishing the Tribunal had come from the PZPR and the political alliances.

Boleslaw Struzek expressed his approval of the bill, saying that, while not perhaps perfect, it was already mature enough to be submitted to the Sejm and its commissions for examination.

Jan Fajecki declared that the bill was a document of exceptional constitutional significance and that the proposals contained in it should reflect both public expectations in this regard and the intentions of all the parties which had sponsored it. He also pointed out that the bill was the result of cooperation based on partnership between the PZPR-ZSL-SD coalition. Kazimierz Barcikowski emphasized that the Tribunal would be an institution of great national importance, one that would be constantly improved in the future. Speakers paid tribute to the experts who had drafted the bill.

It was decided to submit the bill on the Constitutional Tribunal to the Sejm.

The decision taken by Sejm caucus presidiums--writes PAP--means that work on the Constitutional Tribunal bill has entered the final stages. It can therefore be expected that during its spring session the Sejm will fulfill the pledge it made in March 1982 when it amended the Constitution to provide for the establishment of the Constitutional Tribunal.

Let us recall that the relevant clause in the Constitution states that the Tribunal is to monitor legislation and other normative acts issued by the supreme and central state authorities to ensure that these do not conflict with the Polish Constitution. A ruling by the Tribunal that a Sejm law is incompatible with the Constitution is subject to examination by the Sejm. However, a ruling that other normative acts are incompatible with the

Constitution or existing legislation is binding. In such cases, the Tribunal is to take measures to eliminate the incompatibility. Members of the tribunal are elected by the Sejm for their outstanding legal knowledge. They are independent, bound only by the Constitution.

This is what the Constitution says on the matter. The detailed bill now being prepared is to specify how the Tribunal is to operate. In 1981, an all-party group of experts began preparing a report on the bill and the outlines of the bill itself. Work was later carried on in larger working groups, which have been studying the question for over three years. The bill is a complex piece of legislation, unprecedented in Poland. It has also been submitted to public consultation.

One interesting proposal in the bill as it now stands relates to the Tribunal's term of office. This is to be eight years, with half of its members being replaced every four years. This is designed to tie the Tribunal to more than one Sejm term of office, rotating its members while ensuring the necessary continuity.

CSO: 2020/87



VATICAN'S HYPOCRITICAL HUMAN RIGHTS CAMPAIGN ATTACKED

Krakow GAZETA KRAKOWSKA in Polish 11 Feb 85 p 3

[Article in GAZETA KRAKOWSKA: "A Few Questions To TYGODNIK POWSZECHNY"]

[Text] No matter what one thinks about TYGODNIK POWSZECHNY (some people are enthusiastic about it, others are not), one thing is certain--thanks to their contacts with the Church authorities, the weekly's editors are exceptionally well informed on various aspects of Vatican policy. This fact has made me ask TYGODNIK POWSZECHNY for help in explaining some of my doubts.

Reading the foreign press--most of which is bourgeois in nature--I frequently come across attacks on the Church. I will present here a few facts to illustrate these attacks. Before I do that, however, I want to emphasize that unlike many of my fellow countrymen, I treat all sorts of sensational reports appearing in the West with a good deal of suspicion, since I have caught it out on various inaccuracies, to say the least, even with regard to problems concerning the Church.

One such inaccuracy, for instance, concerned the attitude of the church in Chile towards the fascist coup of General Pinochet's junta. It is no longer a secret that the Church supported the junta, but on this particular occasion I read in the Western press that after the legally elected President, Salvadore Allende, was murdered, the bishops sang a "Te Deum," a hymn of gratitude and joy. In the socialist press, however, I read that this allegation was untrue at least with regard to Primate Henriquez.

The Pope's attitude towards the terror which spread all over Chile under the junta's rule is a different problem. That fact that both LE MONDE, which can hardly be suspected of anti-clericalism (The Pope Still Silent About the Chilean Drama; October 10, 1973) and the Catholic paper ESPRIT had serious objections to the extremely cautious attitude of the Holy See toward the events in Chile seems to dispel all doubts. But let us now pass on to more recent events. For instance, at the end of 1983 the popular American weekly NEWSWEEK published Max Westerman's interview with the prominent Catholic theologian Hans Kung. Excerpts:

M.W.: You have often accused the Vatican of being anti-democratic. But don't the pope's incessant calls for human rights in Poland contradict that?

H.K.: I'm not alone in thinking that there is a lack of consistency between the Vatican's foreign policy and its domestic policy. (...) It is no wonder that the Vatican does not want to sign the European Declaration of Human Rights. (...)

M.W.: How does the Vatican's performance in Eastern Europe compare with its policies towards Latin America?

H.K.: There is not much consistency. If the Polish clergy is allowed to speak out on political issues, why shouldn't the Latin American clergy be allowed to do the same?"

It seems that the Swiss theologian's last answer somewhat lacks precision. Latin American clergy are allowed not only to speak out on political issues but also to be actively involved in political activity, provided this activity is directed against the social and political left. Such at least is the impression one gets from reading many Western papers. "Four priests holding positions in the CIA opposed Nicaraguan government, have been ordered to resign. But, the Archbishop of Managua, Miguel Obando y Bravo, taking up collections among American businessmen for a war against the Sandinistas, has not so far even once been reprimanded by the Pope," wrote West German STERN on September 20, 1984. According to the Spanish paper CAMBIO of September 10, 1984, the same Nicaraguan archbishop "organized a rebellious street demonstration in defense of Father Amado Pena, " described by the Italian paper RINASCITA as an "active counter-revolutionary leader."

On November 7, 1984, THE GUARDIAN, a bourgeois English weekly (sic) enjoying wide-spread respect in Britain, printed an article on the methods of struggle against the Sandinista government employed by the "contras" i.e. Somoza supporters hired and paid by American intelligence. Reporting on one episode during the contras' operations against members of farmers cooperatives, THE GUARDIAN described the fate of some members of a Castillo Norte cooperative who had not managed to escape their "liberators" on May 10, 1984. "The contras killed four people with a mortar. (...) They captured 11 people [including one woman, Rosa Sobalvaro]. They cut off Rosa's breasts, then cut her chest and took out the heart. They broke the men's hands, cut off their genitals and put out their eyes. They they killed them all by cutting their throats and drawing their tongues out through the wound." THE OBSERVER adds that since 1981 the contras had murdered 8,000 people. It also produced fragmentary statistics about farms, houses, school buildings and health centers burnt by the anti-Sandinista "fighters for freedom and democracy."

One cannot resist asking if the Holy See knows anything about these horrible crimes. If it does know about them, has it condemned them? Has it told the Archbishop of Managua that collecting the money in a hostile country for such aims, as, for instance, Castillo Nove, is inappropriate? Has it criticized the American administration which is the instigator and sponsor of that cruel, undeclared war?

At the same time we could ask the Vatican's reaction to an episode--which was not at all an isolated one--from the period when Nicaragua was by the grace of

the United States ruled by dictator Somoza. This was an episode when all boys over 12 years of age from the Estela district were murdered because the dictator wanted to get rid of future guerillas. One could ask this question in the context of more recent events, but is it worth the effort? My doubts were aroused by an interview with Fr. Miguel d'Escoto published in the Italian paper L'EUROPEO. In that interview Fr. d'Escoto remarked bitterly, "The Vatican was silent when the Somoza bombed our towns and committed the crime of genocide."

It is worth the effort, however, to find out how much truth there is in the information published by the West German weekly DER SPIGEL according to which "The Vatican adopted a decision to ban funeral services for killed guerillas." (I am inclined to believe the Hamburg weekly this time since I remember that during the January rising some priests loyal to the tsar refused religious consolation to wounded and dying insurgents).

But let us return to the present situation in Latin America, where most governments take every opportunity to declare that they are "defending Christianity" against the threat of communism which according to them assumed the form of liberation theology. The Western press has recently written about pressures exerted by the Vatican on those cardinals and bishops in Brazil and Peru who refused to approve of the curse cast on this progressive theological current by the Vatican's great inquisitor, Cardinal J. Ratzinger. At the same time CON TEMPI NUOVO wrote, "Not a single priest or bishop co-responsible for the torture and disappearance of thousands of Argentina's people has so far been summoned to the Vatican to produce an explanation."

It would also be interesting to learn the Holy See's attitude toward the constant repression of the Brazilian clergy (7 priests murdered, 12 abducted and 395, including 29 bishops arrested), or towards genocide in Guatemala and El Salvador. Were we to believe Paris' LE MONDE, (January 24, 1982) in 1980 the Salvadorean police and armed forces murdered some 3,000 civilians, including women and children and "recently 50 to 60 murders a day were being committed in El Salvador."

The clergy also falls prey to government-organized terror in these countries. The AFP reported on February 27, 1984, that in Guatemala "one diocese was totally abandoned by the clergy, including the bishop, because of numerous murders of clergymen."

Speaking of El Salvador, should we believe STERN which wrote that the Salvadorean clergy for the first time did not observe the anniversary of the death of Archbishop Romero who was murdered by a government death squad at the altar (the murdered archbishop had declared himself in favor of liberation theology).

There are many similar questions which remain to be answered. For instance, how true is the information that under the Vatican's pressure, American bishops toned down their pastoral letter condemning the policy of nuclear armaments, the letter which indirectly criticized Reagan's policy in this respect.

I am asking these questions, since I am quite suspicious of the credibility of some Western papers. If they keep lying about the violation of human rights in Poland, it is also possible that they do not always tell the whole truth about the Vatican's attitude towards instances of genocide and persecution in Latin America. Are my doubts justified? Yes, at least in part they are. I wrote "in part," because the infamous letter by Cardinal Ratzinger of August 6, 1984, the same letter in which he used his worst invective against socialist countries, contained the following sentence: "To a greater extent than ever before, the Church will condemn abuse, injustice and attacks on freedom, irrespective of where these take place and who makes them." Let's wait and see then.

CSO: 2020/85

POLAND

CATHOLIC WEEKLY ACCUSED OF DISHONEST JOURNALISM

Warsaw RZECZPOSPOLITA in Polish 26 Feb 85 p 3

[Article by Eugeniusz Guz: "TYGODNIK POWSZECHNY's Waste-Paper Basket"]

[Text] In my article called "Those Blank Spaces in TYGODNIK POWSZECHNY" which appeared in the ARGUMENTY weekly No. 2/84, I cited several examples to show that TP's excessive sensitivity to press censorship is in stark contrast to its own meticulous self-censorship, to its own practice of sweeping under the carpet whatever may be embarrassing to or revealing about itself. If now, one year later, I return to this topic, then I am doing so with those in mind who admire TP as a model of honest journalism. The trouble is, TP is very far from being a perfect model; if it is a model at all, then it is one of almost ideal imperfection.

Let us start with what are recent examples. In its reports on the Torun trial of the Fr. Popieluszko murder case, TP has been extremely reticent in reporting those critical voices which referred to the Church hierarchy's lenient treatment of extremist actions undertaken by some priests, which showed that Popieluszko was not unblemished, and which recalled the role of Fr. Zych etc. TP almost confined itself to publishing an Episcopate Press Office notice which alleged that these were all "slanders against the Church" and that the Church would not react to them and that was that. But the secular authority is expected to take position even on the most preposterous charges, although many a charge is basically just slander spread by gossip. In its reports from Torun, TP has been editing all facts which are embarrassing to the Church.

When [militia sergeant] Karos was killed [early in 1982], TP confined its reporting to all of two sentences from the court verdict. The Torun trial, to judge from TP's impetus so far, has already filled several dozen full pages in the journal. Would TP please give at least some space to the murder of priests and bishops in Latin America? The above-indicated proportions--or, if you prefer, disproportions--of space devoted to specific topics mark something like a policy line, although TP react with indignation to charges of pursuing any political ends. All that TP does is, supposedly, to provide honest information for readers.

Why can't I then find a note in TP that Primate Glemp has ordered Father Malkowski not to speak in public? Why has this journal, which finds space

even for trifles, taken no note of Minister [for religious affairs] Adam Lopatka's interview in RZECZPOSPOLITA (January 26, 1985), which was really very interesting, especially for believers? Nor has TP noticed Jan Rem's "Insulting People's Feelings" or several articles in GAZETA KRAKOWSKA (by Stanislaw Stanuch), as well as a number of other articles I shall not mention here, which are concerned with sensitive problems of Church-state relations and the coexistence of believers and nonbelievers. On the conflict over the parish priest at Boleslaw, TP had only the Kielce bishops' "message" to report while totally ignoring what the parishioners might have to say about this. I would also like to know TP's opinion about the behavior of the 38 signatories of a protest letter sent to Minister Jerzy Urban, including six priests, who then did not bother to turn up at a meeting in Ostrow Wielkopolski when Urban made the effort of going there in order to get the matter settled on site.

Many critical voices were raised on the matter of the Church-sponsored agricultural foundation. TP, once so vocal about this topic, has become oddly mute now that the anticipated dollars from the West have proved just a phantom. If this isn't a clear case of self-censorship, then what is? I am not going to dwell on the omission in TP's shrewdly compiled "Week in Review" news such as the sentencing of former vicar Eugeniusz Kubowicz to prison for attempting to murder an adolescent girl, or the frequent robberies of churches and presbyteries along with police's successful efforts to seize the stolen property and detaining suspects.

TP practices not only self-censorship but even disinformation. One case in question can be TP's report on detailed data on the Catholic press in Poland in which there is no mention at all of journals published by PAX or other lay Catholic organizations. If TP cannot overcome its arrogance in judging what is and what is not Catholic in Poland, then honesty toward readers at least should induce it to mention in a note that the TP compilation leaves out this press.

TP's internal censors are no less adept in using their scissors when it comes to international problems. The Cracow weekly, which gives evidence of its extreme sensitivity to press freedom by using those blank spaces [indicating censors' interventions] in every issue, somehow failed to notice the loud protests in the West over the Vatican's sanctions against a LA REPUBLICA reporter who had criticized the Pope for being excessively fond of travel. The Vatican did not even bother to reply to a protest letter from journalists, although more than 50 Italian and foreign reporters writing on Vatican matters had stood up for their colleague after his name had been struck from the list of reporters accompanying the Pope on his last Latin American trip. TP editors, I believe, should be particularly wary of putting this kind of news in its waste-paper basket if only a short time ago it castigated the Polish authorities for not granting its reporter an entrance ticket to the courtroom in Torun (TP's reporter attended the trial from the 16th day of the trial, onwards).

If readers relied solely on what TP is letting them know, they would have a very vague idea about the stormy currents and disputes which rock the

Catholic world's understanding of its fundamental doctrines. TP's eagerness in taking up lay domestic matters is in sharp contrast to its slowness in at least signalling what is going on in Catholicism worldwide and how strongly Polish Catholicism differs from that elsewhere. One characteristic example of this was given by TP's special correspondent reporting from the controversial Katholikentag [Catholic congress] held in Munich, when he barely touched the topics taken up during that get-together of Catholics. TP also ignored the proposed notorious pastoral letter of American bishops on the socio-economic situation in the United States, a letter seen in the West as a "criticism of capitalism" and a protest against poverty in the United States. Why is TP incapable of noticing such things?

If readers of the Cracow weekly want to get at least some idea of what is going on in the world of Catholicism, they must unconditionally read the "regime"-sponsored press, for this will be their only source of news (to report only the latest ones) such as actions taken by the Vatican's lay staff for getting better contracts and salaries, or the Swiss Jesuit biweekly ORIENTIERUNG's attack on the Vatican because of the Apostolic See's "manipulations." The nonreligious press in Poland, which has recently been charged in the West with conducting an "anti-Church campaign," has always been reporting on Catholic in-fightings less frequently, and less sensationally, than the capitalist press. This is the truth, and therefore the charge about that campaign is just one more of those lies which so easily flow from the pens of enemies of socialism. You have got to read the Western press to learn that the Catholic Church has lost 250,000 nuns worldwide, 60,000 of them in the United States alone, or that the chasm between canons of the faith and the actual practice of believers is not only not diminishing but even widening.

The backlash of TP's self-censorship can also be seen in reports on papal trips. Let me confine myself to just one remark. During his most recent Latin American trip, the Pope urged priests to abandon political activities and to concentrate on their ministry. The TP correspondent though all but omitted this passage in the papal speech, and he hastened to add--to forestall any associations with the Polish situation--that "In context of the question the Church's and priests' involvement in social and political matters, which is a very sensitive matter in Latin America, this passage could generate misunderstandings." John Paul II also spoke out against "the unbearable abyss" between rich and poor, and urged them [sic] to display unconditional obedience to their superiors. The TP special correspondent, of course, failed to notice any of this.

Nor have I mentioned that TP should be speaking out in defense of Primate Jozef Glemp against what are numerous and frequent attacks in the Western press, including attempts to compare him unfavorably with [Glemp's predecessor] Cardinal Stefan Wyszynski, or against revanchist attacks launched from behind the Elbe.

Nor does the Cracow weekly shy away from manipulation. In TP's "Week in Review," for example, readers could read this: "A few days after being recalled from his post as Czechoslovak defense minister, General Martin Dzur

died (at the age of 65). He headed the defense from mid-1968." In this wording, this note implies a direct link between his being recalled from his post and his death. But in fact there was not even an indirect link between the two facts. The Czechoslovak news agency CTK had previously said the minister was seriously ill since the last year's autumn exercises.

These are all examples taken from recent issues, and more could be cited. It would be a rhetorical question to ask if this peculiar reporting style is typical of TP only or if other journals, spiritually akin to it, have also assimilated it. For anyone who has at least some experience of the reporter's trade, these examples bear an unequivocal message. It boils down to the saying, *Medice cura te ipsum* [Doctor, cure thyself].

CSO: 2020/88



## BOUNDARIES OF COLLECTIVE BARGAINING PROCESS OUTLINED

## Purpose of Collective Bargaining

Warsaw RZECZPOSPOLITA in Polish 7, 8 Jan 85

[Article by Maria Matey: "Law and Decrees: The Purpose of Collective Bargaining"]

[7 Jan 85 p 6]

[Text] What is the purpose of collective labor agreements in Poland? To put it in a nutshell, their role can be summed up under five [sic] heads: the normative one; as the source of labor legislation; as the means to ongoing improvement of the working and living conditions of the working people; as a way to implement the economic reform and to achieve other general social targets; as a way to defuse situations in labor relations; and as a continuation of the 1980 social contracts.

Collective labor agreements are the source of legislation, i.e., they include legal standards binding on both parties to the agreement, as well as on third parties. They are legislative acts not unilaterally enacted by state organs (the mode of social consultation does not deprive legislative acts of their unilateral character), but constitute law created through collective bargaining (negotiations); hence, the unique value and the social significance of collective agreements as a way of legislating in matters related to labor.

## The Source of Law

In post-war Poland the experience of collective labor agreements is divided into stages of development and those of unfortunate regress. Until 1975 the agreements played--for lack of codified labor legislation--a major role in the clarification and shaping of the socialist labor law, anticipating legislative decrees in introducing new legal solutions and new benefits, as well as in the development and specification of legislative regulations. The early development of collective agreements can thus be divided into the 1946-49 period of spontaneous growth, followed by regress caused by the excessive centralization of the economy in 1950-55, and another revival after 1956 which lasted until 1975, when the newly passed Labor Code assumed the task of defining labor conditions; although collective agreements continued, their substance was severely curtailed.

Article 238 of the Labor Code restricted the issues regulated by collective agreements to two questions only: 1) detailed terms of remunerating employees and granting other benefits; 2) labor conditions derived from the specific character of various branches or professions. The view prevailing among experts in labor jurisprudence considered that the Labor Code too narrowly restricted the scope of permissible regulation by means of agreements (i.e., the objective scope of the agreements); this reflected the trend toward centralization and managerial preponderance which dominated in the mid-1970's, and the then not purposeful enough attitude of labor unions in this matter.

Seventy-seven collective agreements signed in the second half of the 1970's, and involving some 9 million employees, are still in force today.

#### The Promotional Role

Collective labor agreements, as a "mobile" instrument (unlike static laws), should promote the cause of improving the legal and the living standards of labor through immediate and reliable reaction to the changing needs and possibilities, through pilot or experimental introduction of new legislative solutions and benefits, through their dissemination subject to their soundness, as well as through creation of conditions (and pressures) for mature legal measures. It should have played a similar role in improving the wage systems and increasing wages, with recourse to lower level agreements, such as enterprise wage agreements provided for in the January 1984 law.

It is important to prevent the downgrading of the "promotional" role of collective agreements due to the crisis conditions in the economic situation, since they should be implemented through negotiations, not through systemic constraints.

#### The Sentry Link

Collective agreements should become the "sentry" link between labor legislation and the reformed economic system; thanks to their mobile character, they should promote changes in the labor legislation, parallel to the various stages of the economic reform; ease the passage from one stage of the reform to the next; and in some cases precede, or even provoke, desirable economic changes. The Hungarian solution illustrates the specific interaction between collective agreements and the economic reform: in the early, and most intensive, stages of the Hungarian reform, agreements were signed for just 1 year; subsequently their validity has been synchronized with the 5- and 7-year economic cycles.

#### How To Cope With Conflicts

In addition to their regulative functions, collective agreements in our contemporary world serve as a means of settling ad hoc conflict situations at the possible lowest structural level, and at the possibly smallest social cost. Such agreements often crown post-strike settlements. Because of

those functions, the substance of such agreements should not be restrained: the idea is to make the solutions of all collective conflicts possible through collective agreements.

Under the circumstances prevailing in Poland there is no reason to reject this role of collective agreements; it is extremely sensible to crown all collective conflicts--subsequent to their solution in accordance with the mode provided for in the Trade Union Law--with the signing of a new collective agreement which would restore order in matters which had been previously contended, in particular since the Trade Union Law does not indicate, for instance, what form such post-strike agreements should assume.

Collective labor agreements, as a form of social reconciliation, might well extend the 1980 social contracts in the period of normalization.

\* \* \*

Collective labor agreements would be able to fulfill all the above-mentioned roles only if the legal power to sign such agreements is granted not only to entire industrial branches, but also to all labor groups which have substantial grounds for aspiring to collective agreements of their own. That includes, for instance, workplaces with specific, atypical work conditions, or enterprises which thanks to the more intensive contribution of their work forces claim exceptional but steady productive and economic accomplishments. Even if such a procedure could be introduced only after a lapse of time, the legal entitlement to sign individual agreements under specific circumstances should be safeguarded already at an early stage of preparing the legal model of the agreements.

[From the editors] This paper, by Docent Maria Matey (its second part will be published in our next issue) was presented at a conference convened by the Institute for Legal Studies of the Polish Academy of Sciences; the conference was devoted to collective labor agreements.

[8 Jan 85 p 6]

[Text] In her previous article, Doc Maria Matey dealt with the role of collective labor agreements in the People's Republic of Poland. Today she writes about the problem of negotiating agreements and their substance. Both parts were presented (as theses, titled "Collective Labor Agreements") at a conference convened by the Institute for Legal Studies of the Polish Academy of Sciences.

Until now the procedure of negotiating collective agreements--which in many countries of the world (the English-speaking ones in particular) is the crucial problem in labor legislation--has been virtually neglected. The significance of this problem has emerged in connection with the recent revival of the independence and the offensive character of trade unions in Poland. Broadly conceived, the procedure for negotiating agreements includes the following subjects:

## What Problems?

- a) The bargaining parties (the question of enterprise representation for negotiating branch agreements, as far as both the employers and the labor unions are concerned, is now being discussed);
- b) The bargaining power of the parties and their mutual recognition (this problem was dealt with by Walery Masewicz in RZECZPOSPOLITA No 305, 21 Dec 84, and No 309, 28 Dec 84);
- c) The obligation to engage in bargaining (as a rule, it concerns the employers' representatives, and is set in motion by labor representatives);
- d) Preparing bargaining positions (internally agreed-upon positions of both parties). World literature indicates some difficulties in this area, due to the multiplicity of represented groups, interests, and pressures. Trade unions have special difficulties in selecting their demands to be included in the agreements--abroad it has been claimed that to maintain the support of their rank and file they tend to multiply demands rather than to put them in more general terms.

One can also see both parties raising their starting positions (bluffing), with subsequent concessions in mind; the parties are then more hard-pressed to recognize the actual positions. It has been noted that such a procedure might be dangerous to the unions, as it might impede gaining rank-and-file approval for subsequently agreed conditions (charge of excessive concessions);

- e) Perceiving the sense of bargaining as "striving at a compromise" or else "looking for a solution appropriate for the superior common goal." The "compromise" theory pushes toward demanding concessions--even unjustified ones--at any price, for prestige or electoral purposes. The theory of a "supreme common goal" might imperil the dynamics and the offensive spirit during negotiations. More profound reflection on the problem of the essence and aims of collective bargaining in the socialist system therefore seems indicated;

- f) Technical preparation of bargaining issues: the kind of materials and analyses needed, the number and the qualifications of the staff which prepares them, the use of computer technology, the assistance of independent experts, the enforcement of the employers' duty to provide necessary information;

- g) The sense of determining, and abiding by, agreed-upon rules and modes of bargaining: the timetable, the chairmanship, forms of motions submitted, pronouncements and information, the taking of notes and minutes, etc., the choice of a neutral venue for bargaining.

## The Substance

Polish and foreign literature on labor legislation lists the provisions of collective labor agreements according to the criteria of their legal character: 1) normative ones, which set up standards binding for the

negotiating parties and for third parties; 2) mandatory ones, which include the mutual obligations of the parties to the agreement. This distinction should be maintained for the theoretical and legal qualification of various agreement provisions.

As far as the new model of collective agreements in Poland is concerned, the most essential issue relates to the definition of their substance, i.e., the scope of problems which are to be subjected to regulation by agreement. The functions collective agreements are to fulfill (in particular their promotional function to raise the legal and economic standards, their complementary and pilot function to seek new solutions prior to their legislative enactment, and their function of defusing conflict situations in workplaces) demand that their scope be extensive, and in no case a priori restricted by law. All restrictions impair the functions of collective agreements, and deprive them of their genuine significance. The essential question, therefore, is to give up any drastic curtailment of the substance of such agreements, introduced by the Labor Code (article 238) in accordance with the centralization trends of the 1970's. One might point out that such restrictions contributed to the fact that by 1980 no controversial social and labor problems could be settled in the usual way through bargained agreements, thus provoking an escalation of political events nationwide.

#### Collective bargaining

Convention 98 of the International Labor Organization on the right to organize and engage in collective bargaining, ratified by Poland (DZIENNIK USTAW 1958, No 29, item 126), provides in its article 4 support for collective agreement bargaining to regulate work conditions; the convention does not recognize any restrictions on the substance of bargaining. Experts in labor law understand the term "conditions" as describing not only the conditions under which work is being performed, but also all the provisions included as essential components in the substance of labor employment.

To accept the broad scope of the objective substance of collective agreements would require a definition of the relationship between their provisions and the labor code or other laws. Foreign legislation (e.g., in France) has assumed that in all cases, except those involving elements of protection of public order, such agreements may include provisions more favorable to the workers than the legal standards. Polish labor jurisprudence might well work out similar criteria for dividing the code standards into those that are unconditionally binding and those that might be replaced by agreement provisions more favorable to the workers. This would in no way imply that collective agreements would bring about an avalanche of immediate disavowal of the labor code provisions; such a contingency would be prevented by the social responsibility of the bargaining parties, as well as by the proper corrective machinery linked to the agreements. The important thing, however, is to avoid the imposition of inflexible legislative restrictions on the substance of the agreements.

## Trade Union Speaks Out

Warsaw RZECZPOSPOLITA in Polish 1 Feb 85 pp 1, 2

[PAP report: "Concerning the Preparations for a New Concept of Collective Agreements: Two Proposals Submitted"]

[Text] On 31 January the government/union team for the legal regulation of collective labor agreements convened for its second session.

The team, set up 2 weeks ago, includes representatives of various ministries and of the Nationwide Trade Union Agreement [OPZZ]; at its first session it has selected a mixed working party to discuss the preliminary draft law, prepared by the government for solving this exceptionally complex issue. At the same time, the OPZZ representatives consulted with countrywide labor organizations, and concluded that they would have to prepare a draft of their own in accordance with the union members' expectations.

The decision followed a controversy between the government and the unions on many essential points, including, for instance, which parties would be entitled to sign agreements. Similarly controversial are the proposals for a continuing "freeze" of allowances in kind and of other branch benefits in kind, and their gradual easing out (in order to increase those wage components which are directly related to work results). Some draft proposals, which--according to the unions--reduce the significance of collective agreements as the source of law, as well as the role of the nationwide labor union representation in enacting executory provisions to the future laws, are also being put in question.

It has been resolved that at the next session of the team, to be held on 27 February, the unions will submit their own proposals. At the same session the detailed timetable and the mode of future team deliberations will be agreed; those deliberations will deal with two drafts: one submitted by the government and the other by the unions. The team will decide, inter alia, how much of the proposed new legislative regulation of collective labor agreements (as far as they revise some parts of the Labor Code) should --in its opinion--be submitted for consultation.

12485

CSO: 2600/605

ACADEMY OF SCIENCES PUBLISHES ACTION PROGRAM FOR 1984-1986

Warsaw NAUKA POLSKA in Polish No 4, 1984 pp 135-147

[Article: "The PAN Program of Activities for the 1984-1986 Administrative Term"; the program was discussed at a 28 February meeting of the PAN Presidium and approved by a Presidium panel on 26 March 1984]

[Text] Introduction

1. General Prerequisites for the PAN Program of Activities for the 1984-1986 Term

Work aimed directly at formulating the PAN program of activities for the 1984-1986 term began at the end of 1983, but the elements and proposals that had to be considered for this program were developed, presented and enlarged beginning in 1980. Here one should keep in mind the 53rd PAN General Assembly, held in October 1980, at which a critical analysis of the status of Polish science was made, indicating the basic directions of scientific activity. The deliberations of the PZPR Ninth Extraordinary Congress provided many good suggestions and tasks for science. The role of science in developing a modern socialist society was emphasized in the congress resolution, and tasks were assigned defining the directions for developing science and improving its organization and for science to support the country's cultural and socioeconomic development. In addition to the scientific tasks, the congress resolution contained assurances of the party's attention and concern about the status of the PAN and about creating conditions for expanding scientific activity.

A more extensive analysis of the status of science, its directions of development and organizational improvement was presented in the papers and discussions at the 57th PAN General Assembly in January 1983 and at the 59th PAN General Assembly in December 1983.

In developing the PAN program of activity for the 1984-1986 term, it is necessary to execute a total evaluation of the last term. Unfortunately, this analysis must be critical because, without placing blame for PAN's current situation, it should be stated that in the wake of the extensive discussions, analyses and recommendations, significant changes did not occur in the organization of science and its links with the economy and social life. In addition, satisfactory material conditions for scientific activity also were not ensured.

To a great extent, the sociopolitical and economic crisis affected this status. Science has not started to fulfill the hopes placed in it; however, the conditions for accomplishing this were not provided. In addition to participating in making organizational changes to control science and its associated legislative acts, the PAN directors focused their attention on protecting science against the effects of the crisis and maintaining its resources. The uncertain material conditions hampered activity and impeded more daring activities in the area of organizational changes and in correcting research directions. It should be added that under the crisis conditions, the reform-induced self-government of units of the national economy engendered an unwillingness on the part of these units to commit funds for "investments for the future," including scientific research. Economic instruments were lacking that would have elicited the economy's needs for new scientific developments. Finally, there was no open dialogue between the authorities and the scientific community. In recording the presented status factually, especially the large number of proposals and recommendations that were acknowledged to be good, it seems to be obvious that the PAN 1984-1986 administrative term should initiate the expected changes in the organization of science that will lead to expanded cooperation between the authorities and the scientific community, stimulate links between science and the economy and activities designed to overcome the economic crisis, outline the directions of scientific research during the 1986-1990 period, and assure scientific researchers stable organizational and material conditions. The preparations for and the deliberations of the Third Congress of Polish Science in 1985 should provide opportunities for internal consultations within the scientific community and a dialogue between the government and the scientific community. However, we must not wait till the congress takes place to examine problems that are vital for developing Polish science. Preparations for the congress should go hand in hand with increasing the role of science in Poland's economic and social life because that is the only way to rebuild the authority of science in Poland.

## 2. The Program Development Progress

The draft of the PAN program for the administrative term was reviewed by the PAN scientific secretary on 14 February 1984. As a result of the discussions at the PAN Scientific Secretariat meeting, a revised version of the draft was presented to the PAN Presidium on 28 February 1984. After the revised draft was reviewed at the PAN Presidium meeting, additional proposals and recommendations were made, and the present version of the progress was prepared, which was approved by a PAN Presidium panel at its 26 March 1984 meeting.

### I. The Main Directions of Scientific Research That Are Especially Important for the National Economy

One hears public criticism that the basic research conducted by the PAN can be applied to the current needs of the economy only to a small extent. In addition to science's cognitive and culture-forming functions, society expects science to influence the development of all sectors of the national economy in a material way and to produce results that are socially perceptible. Poland's exceptionally difficult economic situation, the increasing technological gap between Poland and the most developed countries and the immense



research potential of PAN's scientific institutions are reasons for PAN, in addition to conducting basic research, to start working harder than heretofore on problems and utilitarian tasks to develop the country. In undertaking these tasks, the PAN cannot wait for these tasks to be considered only in the research plan for the next 5-year period. The national economy needs cooperation with science, regardless of the still impervious system of interactions and financial relationships between industry and science. The 2-year mark of the present PAN administration term coincided with the completion of the present 5-year plan. During this period, PAN's institutions, in cooperation with other research units, will conduct research in accordance with previously established and approved plans for the current 5-year period. Research results of individual problems will be evaluated annually. In this period it will be difficult to make substantial changes in advanced research programs. Despite these objective obstacles, reserves in the research capabilities of the scientific institutions must be found, and organizational forms permitting the expansion of research in accordance with the priority needs of the national economy must be established.

Selecting those planned research themes whose results could be applied in economic practice and concentrating our efforts on implementing these results will be primary tasks. Scientific research units cooperating with PAN institutions and scientific committees should be included in activities to help the economy.

Linking together the cooperation of PAN's scientific institutions with large industrial enterprises and units of industry's scientific facilities will be necessary. The initiative and active participation of PAN's departments and institutions are essential in undertaking this cooperation. Scientific research for the economy's current and future needs will be detailed in the basic research program for the 1986-1990 period, which will take into account the modifications that are needed in the system for organizing and financing this research. This research will be an important PAN activity in the area of basic research for the 1986-1990 period, and it will be an important criterion for verifying the national basic research program for the 1984-1985 period.

Based on the initial evaluations and discussions at the PAN Scientific Secretariat meetings of December 1983, January 1984 and February 1984 and at the PAN Presidium meeting of February 1984, the PAN, in cooperation with the higher schools and ministerial institutions, will be able to undertake expanded research programs in the following areas that are important to our country's development:

1. An analysis of the processes for reforming the mechanisms of the national economy's functioning in order to evaluate the factors helping or hindering the rationality and effectiveness of management and to develop recommendations and guidelines to improve the mechanisms of reform, especially the systems of motivations, including improving the receptivity of innovations.
2. Apply the accomplishments of science to form conditions for the rational exploitation of the nation's wealth. This complex problem should be considered by all cells in the economic sphere using technical, economic and organizational resources and methods. Science (including PAN institutions) should

concentrate its attention on preparing and developing computer systems to control manufacturing processes; on working on second-generation robots; on implementing a computer method to aid the creative processes (especially design processes); on optimizing large economic systems (for example, agriculture, transportation, industry); on using machines, electric drives and working machines as means of transportation; on developing new materials and energy-saving technologies as well as new materials and plastics to limit dependence on imports (for example, special polymer plastics, including structural plastics, and VVDS resins having piezoelectric characteristics; the application of high pressure technologies to thicken ceramic products; preparing technology to disperse water in ethyl gasoline and diesel oil to save fuel; limiting the pollution of the environment; and improving the efficiency of drive motors).

3. Technology for producing chemical products and semiprocessed products to satisfy current and future needs of the national economy and to limit import dependence. Thus, research potential should be focused on:

--developing the physiochemical bases for technological processes, that is, a suitable selection of catalysts, thermodynamic parameters to model the heat exchanging processes, and processes for separating and purifying chemical substances;

--mastering the chemical syntheses of compounds and materials having properties not yet achieved in domestic production, increasing the assortment of biologically active compounds, polymer plastics and the like;

--improving existing and projected chemical technologies from the viewpoint of increasing their efficiencies and rationalizing the use of energy and materials.

Carbochemistry should be one of the priority specialties of Polish industry. Therefore, it is necessary that research teams in many scientific disciplines concentrate their activities on processes for processing coal tar, on developing new processes to convert coal to a clean source of energy and chemical raw materials based on mastering the physiochemical bases of these technological processes and studying thoroughly the structure of Polish hard and brown coal.

4. The problem of modern electronics, especially mastering the production of the new generation of microprocessors and applying microinformatics to the economy. Poland's research potential and existing accomplishments, especially in the material base, should be concentrated on:

--preparing technology to process new-type materials for electronics and microinformatics, and testing and characterizing these materials (semiconductors, magnetities, superconductors and dielectrics), which will enable the design of electronic components and instruments based on the new phenomena occurring in these materials, providing useful parameters that are much better;

--investigating information science optoelectronics, developing modern equipment for telecommunications based on fiberoptics and laser material, and

applying microelectronics more extensively in industry, in automation, in engineering equipment and in designing scientific apparatus;

--developing and mastering methods for manufacturing and producing materials and components that are difficult to achieve and that have unique properties, such as nuclear and infrared radiation detectors, Hall generators, a superconducting switch and the like.

5. Rationalizing the consumption of energy and using new energy sources should in effect lead to reducing the energy intensiveness of the national economy while satisfying socioeconomic needs that are characteristic of modern states.

To achieve this goal, research potential will be directed toward:

--developing and implementing scientific methods to improve the effectiveness of undertakings to rationalize the use of fuels and energy, especially via a method that is not contingent on major investment outlays, that is, to improve the operation of energy arrangements and their efficiency, which, as indicated by the most recent research, are the sources of about 85 percent of the possible savings in fuel and energy up to 1990;

--creating, from the viewpoint of the entire economy, methodical bases for the proper allocation of investment outlays associated with rationalizing the use of fuel and energy after 1990, especially projects designed to reduce heat waste in buildings and to increase the recovery of waste energy; new, economical technologies; improving the quality of produced raw materials and the quality of energy carriers; and implementing more extensively automation and better measuring methods and equipment;

--developing and building equipment guaranteeing improved efficiency and reliability of power machinery and equipment in the present technologies to obtain and process fuel and energy and in future technologies that take into account new energy sources and carriers, energy conversions and new energy equipment and machinery;

--investigating the practical possibilities of using new energy sources under Polish conditions primarily for local uses, such as wind energy, energy of small water streams, mainly mountain streams, solar energy, thermal energy (Podhale), biogas, small deposits of brown coal and natural gas and others.

6. Rationalizing the exploitation and use of mineral raw materials. It is necessary to develop the scientific bases for shaping an effective state policy in the area of using native mineral raw materials for the needs of the country and its participation in international cooperation. An effective model must be developed for managing mineral raw materials, starting with amending the methodology for seeking and recording these resources, through rationalizing the exploitation of mono- and multi-raw-material deposits, minimizing exploitation wastes, improving the effectiveness of enriching and refining raw materials, especially with regard to recovering byproducts. Developing modern and efficient methods to process mineral raw materials is an important problem. All of this should lead to an extensive restructuring of the raw material industry.

A separate problem is the intensification of research to develop methods to minimize the destructive effects of the mining industry on the environment and to recultivate excavated areas. It is necessary to investigate the changes in earth formations caused by mining activities and their resulting consequences.

7. The bases of the economy and protection of the environment, especially water management, including the seashore; dislocations in water relationships and dislocations caused by the exploitation of raw material resources and hydro-technics. The introduction and dissemination of technologies that produce little or no waste and the development of practical principles that are socially and economically beneficial for shaping and using the environment under conditions of strong industrial growth are urgent tasks.

It is necessary to increase work to study the ecological status of areas that are especially threatened, especially inland waters and industrialized and urbanized regions, and to study the extent, tempo and trends of degradation of environments that are being heavily exploited economically, and to develop variant-type prognoses for the economically more important types of environments in Poland (agricultural, forest and urbanized environments). The important tasks are: to develop ecological methods for monitoring the status of the environment and for a national monitoring network; to develop ecological models to optimize Poland's primary landscapes (agricultural, industrial and residential-urban for regional planning and environmental protection purposes); to intensify activity to protect nature on a regional basis and on a species basis; to implementing biological methods to combat pests and additional application of methods to recultivate waters.

8. Molecular biology and applying its results in industry and agriculture. The development and application of biotechnological processes in the chemical, pharmaceutical and food industries and to protect the environment.

First of all, we must obtain and apply designated mutants of microbes to create biologically active substances such as antibiotics, hormones, vaccines, and enzymes. To this end, we must further develop genetic engineering technology, the bonding of enzymes to an insoluble base, and the technology of meshing bacteria cells to construct practical enzymes that are essential in biotechnological processes. Forming desired useful traits for plants and animals and genetic engineering are future directions for molecular biology applications.

9. Agriculture and food, especially the optimal functioning of agricultural management and improving the effectiveness of the functioning of the economic reform in agriculture. Creating scientific bases for increasing the efficiency of agricultural production, plant as well as animal; reducing post-harvest wastes; better utilization of domestic fodder; rational management in rural areas; implementing an optimal model for interaction between agriculture and industry; improving processing efficiency; improving the quality of food; and reducing food wasted during processing and handling and in storage.

10. In improving the level of health care, the primary role of the nerve, hormone and immune mechanisms in regulating homeostasis under conditions of health and in states of sickness depending on the changing work and life environments

are well known, and research should be concentrated on these mechanisms. The immediate goal of this research, which today demarcates progress in prophylactic, therapeutic and rehabilitative treatments, should be to obtain new medications, to rationalize treatment methods and to develop new diagnosis and treatment methods and equipment. Realizing this goal will be closely associated with developing the chemistry of biologically active compounds, engineering biocybernetics, biomedical engineering and acoustics.

11. Expanding comprehensive research on shaping the personality of the contemporary Pole to recognize more extensively the interdependence between phenomena dealing with personality and social consciousness and the organization of cultural and sociopolitical life. In particular, research should be expanded on the real value system, aspirations and attitudes of various social groups and classes regarding the needs of the country, work and work productivity, and on individual models and national attitudes and to develop, among other things, the bases for forming programs and improving the system for educating and rearing young people.

12. Demographic problems and their associated social effects. The scientific potential of demographers and related sciences should be concentrated on seeking new (mainly demometric) and improving existing research techniques and methods and on formulating principles for the rational forecasting and shaping of demographic processes as well as the interaction of demographic and social development under conditions of a socialist society. The principles of rational influence on demographic processes under Polish society's conditions as well as the socioeconomic effects of the current and future demographic processes should be especially defined and formulated.

Above all, intensive research should be conducted on those themes in which, with the given scientific base, one can expect measurable results in the not too distant future.

It is proposed, based on the mentioned thematic proposals and our own recommendations, that the PAN departments develop the research priorities that are especially important for the national economy. In parallel with developing research priorities, proposals should be developed regarding the organizational forms for basic research to resolve economically important research in the PAN, which will also take into account their financing sources.

## II. Improving PAN's Organization and Conditions for Scientific Activity

### 1. The Basic Research Program and the System for Financing and Planning Research for the 1986-1990 Period

The creation of stable conditions for scientific research activities and developing basic research plans for the 1986-1990 period are PAN tasks that are especially important in the current term.

Developing and disseminating the principles for planning and coordinating basic research after 1985 under economic reform conditions is the starting point for executing this task. In developing the principles, we must make use

of the good experiences and learn from the bad experiences of the present system for planning and coordinating research, striving to concentrate efforts in selected directions.

In parallel with work on the principles for planning and coordinating research, the PAN will cooperate in preparing a Council of Ministers resolution regarding the principles for financial management of research units. The PAN will also initiate internal action to improve the financing system for PAN institutions by expanding the principles for accumulation of costs in scientific institutions (payments to publishers, self-financing scientific functions, foreign cooperation costs and the like).

Work will begin immediately on preparing the basic research program for the 1986-1990 period. This program, in addition to considering world scientific trends and the capabilities of the Poland's scientific research institutions, must also consider to a greater extent than heretofore the national economy's contemporary and future needs. The development of the basic research plan will be preceded by the preparation in 1984 of general assumptions and the selection of priorities. The coordination plans for basic research during the 1986-1990 period should be developed and approved by mid-1985.

All stages of work on preparing the basic research plan for the 1986-1990 period will be accompanied by consultations and continual cooperation between the PAN and the MNSzWiT [Ministry of Science, Higher Education and Technology] and ministerial institutions, and by consultations at the scientific community level that will be conducted by the PAN scientific committees so that the accepted plan will take into account all the thematic postulates and the possibility of using the scientific potential of PAN's institutions, the higher schools and the ministerial institutions. The cooperation between the PAN and the MNSzWiT in developing the basic research plan and the scientific cooperation among the PAN institutions, the higher schools and the ministerial institutions, which will be more intense than heretofore, should facilitate in a decisive way the elimination of the barriers between sectors of Polish science.

The postulated Council on Basic Research should play an important role in planning basic research. The evaluations and opinions to be received at the Third Congress of Polish Science most certainly will have a large effect on the form of this plan.

## 2. Cadre Policy and Cadre Training

The present cadre situation in the scientific institutions is causing much anxiety in the scientific community. Two basic factors are affecting this situation negatively: limited financial resources and the indifferent social attitude of a portion of the scientific community, as indicated in extreme cases by a demonstrated unwillingness to cooperate in resolving the country's socio-economic problems.

The limited resources for scientific research and that which follows, the relatively low wages, restrained increases in the number of scientific workers in PAN's institutions, causing stagnation in the flow of cadres and practically stopping the flow of young scientists to the institutions.

The situation for engineers, technicians and assistants, which is also financially based, is even more difficult. A continuation of this state of affairs will bring about a serious generation gap in science and make it impossible to obtain good scientists. The PAN administration must take effective, comprehensive action during this term to change this state of affairs.

It is essential to guarantee a flow of young scientists to PAN's institutions by increasing employment and by continuing to employ in PAN's institutions only those people who have the required predisposition and produce results in scientific research work. The planned review of scientific cadres employed by the PAN institutions, which was organized by the departments with the aid of the scientific councils, is supposed to serve this purpose. In addition to high scientific requirements, it also is important to create good working conditions in PAN's scientific institutions.

The wage policy should help resolve the cadre stagnation problem. PAN's goal is to guarantee average pay in the "science" sector at a level that is no lower than the average pay in the socialized economy and to implement pay equalization in individual divisions of science. In the future, average pay in "science" should rise in proportion to the rise in average pay in the socialized economy. Greater pay differentials among scientists also is essential.

The PAN scientist will be required to show a proper civic attitude, expressed, among other ways, by presenting attitudes in accordance with Poland's constitutional principles and by doing work to satisfy the country's economic and social needs. In addition to scientific achievements and participation in training cadres, presenting a civic attitude will be an element taken into consideration when reviewing scientific cadres in PAN institutions.

Improving the training of scientific cadres will be an important activity. It is necessary to develop forms for improving doctoral studies, to improve their effectiveness and accelerate the process, and to combine scientific training of young scientists with shaping their ideological and political attitudes. An extensive reorganization of PAN's doctoral studies system is necessary to execute this task. One of the proposed resolutions, which needs to be reviewed, is to create a central PAN doctoral department having modified rules for the selection of doctors and the course of studies.

Finally, an extensive analysis is required of the existing system for scientific advancement that has been in force for many years, that is, obtaining science degrees, removing scientists during a period in their life recognized to be the most creative, the realization of priority research problems and participation in applying scientific research results. This analysis will be conducted before the Third Congress of Polish Science.

### 3. Scientific Cooperation With Foreign Countries

The PAN attaches great importance to expanding scientific cooperation with foreign countries, considering it to be an important element in training scientific cadres and in solving research problems.

However, for objective reasons, the possibility of increasing scientific cooperation with foreign countries, especially capitalist countries, is limited. Thus, in addition to efforts to obtain foreign exchange funds to expand cooperation in directions that are in accordance with research plans, it is necessary to reorient cooperation with foreign countries by specifying goals, selecting priority problems in cooperating with foreign countries regardless of their links with government problems, and comprehensive and ministerial problems, and expanding and extending contacts with the socialist countries, especially the Soviet Union, in the area of bilateral and multilateral cooperation. The exchange of personnel and the financial funds allocated for this will be subject to established priorities.

Improved mechanisms will be introduced to evaluate the effectiveness of cooperation with foreign countries with regard to its usefulness in expanding research that is basic and utilitarian for the country's socioeconomic development.

#### 4. Popularizing Science and the Activities of Scientific Committees, Divisions and Departments and the Social Scientific Movement

In accordance with the resolutions of the PAN General Assembly and the PAN Presidium, it is essential to strengthen the role of the scientific committees. To this end, preparatory work has been initiated to appoint and add economists and competent representatives of the ministries and social institutions to the committees to work with the scientists. The aim here is for the committees to be institutions where science and the economy meet and whose effects are specific and effective.

To accomplish this, a specific program of action for the administrative term will be developed after inputs of the individual scientific committees that were generated during the first half of 1984 have been considered.

Representatives of PAN's directorate plan to meet with the chairmen of the scientific committees to discuss the guidelines for activities of the scientific committees for the 1984-1986 term. They will guide the work of the committees especially with regard to making preparations for the Third Congress of Polish Science, the tasks resulting from the PAN program of work in the realm of programming and social control of realizing scientific research plans, and of verifying the scientific research plans financed by the committees in light of the system for planning and financing scientific research with the PAN plan for economizing; evaluating the level and quality of the scientific cadres, the methods for training them and the direction of this training; determining the status of scientific publications, especially periodicals and the level of scientific critiques; and determining the scientific counseling linked with overcoming the nation's difficulties and accelerating its development. This work will require a general outline of regulations for the scientific committees. An analysis and evaluation of the organizational and material conditions of the committee activities should lead to proper decisions.

An analysis of the level of cooperation between the scientific committees and the scientific commissions of the divisions, which are in essence individual, territorial commissions of the committees, would be desirable and important.



This analysis is related to preparing the report on PAN's divisions, their place in the PAN organization, their participation in realizing PAN's work program and their place and role in scientific life and work for the macroregion.

During the current term, the PAN will take action to implement the postulates of the Council of Scientific Associations, which were reviewed by the PAN Presidium, concerning the development conditions and directions for the social scientific movement in Poland. To prepare the groundwork for the discussion at the meeting of the PAN Presidium, it will be necessary to analyze and examine PAN's organizational and financial links with the scientific associations because PAN's guardianship of and cooperation with the associations cannot be limited only to financial ties.

The recommendations generated by the Council for the Popularization of Science, the Council of Scientific Associations and the PAN University will form the basis for work in the area of disseminating science.

The PAN Presidium will devote more time to the activities of PAN's divisions and their role in local scientific communities. To evaluate the situation and provide guidelines for activities, a report will be generated on PAN's divisions, their place in the organization and their participation in realizing PAN's program of work.

In division activities, in addition to executing statutory tasks and authorizations submitted by the PAN scientific secretary, it is important to develop a program of work and plenary sessions that will take into consideration the specific links and cooperation between science and the economy, which were discussed in the papers of the representatives of PAN's administration and the directorates of enterprises.

#### 5. Applying the Results of Scientific Research

It is a fact that the economic reform is being introduced under disadvantageous conditions and has been in effect for only a short while. In addition, many of its projected or elicited mechanisms have not yet begun to function to a satisfactory degree. However, the fear is rising in the scientific community that industry's current lack of interest in cooperating with science will continue. This in turn, along with the lack of funds to purchase licenses and technologies, will widen the technological gap between Poland's industry and the industries of the highly developed countries. Finding a solution to the presented impasse most certainly will be one of the primary tasks of the Committee for Scientific and Technological Progress. The PAN is very interested in resolving this problem. It is planning to devote a portion of its potential to utilitarian research to assure for itself a flow of additional funds for this research. Thus, the PAN directorate will take initiatives and cooperate in improving the system for applying the results of scientific results to the economy.

#### III. Cooperation Between the Scientific Community and State Authorities

Expanding the dialogue and cooperation with the government and other organs of the central state administration is an important task during the current

term for the entire scientific community, especially the PAN. The PAN, representing all scientific communities by way of its members, its network of scientific committees and its links with Poland's scientific associations, is especially competent to undertake such a dialogue.

#### 1. Providing Opinions on Legal Acts Concerning Science

The participation of PAN opinionmakers in the preparation of legal acts, which are being implemented in the present organizational system of Polish science, should be one of the areas of dialogue and cooperation, especially the draft to create the Committee for Scientific and Technological Progress and the division of authority among this committee, the Ministry of Science, Higher Education and Technology, and the PAN. The PAN should have a voice in judging the proposal to create a Council for Basic Research. The legal acts regulating these matters designate PAN's place in Polish science and will have an important bearing on the content of the projected changes in the laws concerning the PAN and on the execution of the regulations of these laws.

The PAN should assume the role of opinion giver in developing and passing other legal acts concerning science, especially with regard to laws on science degrees and titles and laws on scientific research institutes.

In all its opinion giving activities, the PAN will cooperate with the Ministry of Science, Higher Education and Technology.

#### 2. Counseling by Science

The participation of the PAN in developing a long-term program for structural changes in our economy, on the basis of which it will be possible to make good decisions on investments, scientific research, technical progress and international cooperation, is another area of dialogue and cooperation with the government. This task is included in the resolution of the 14th Plenum of the PZPR Central Committee of November 1983.

In accordance with the resolution, such a program was supposed to be developed by mid-1984 so that it could become an integral part of the National Socioeconomic Plan for the 1986-1990 Period. Among Poland's scientific institutions, the PAN is certainly the best qualified to provide scientific opinions in this matter. Undoubtedly, the time to prepare this opinion is short. However, it is difficult to imagine that this program, which will be available in several months, would be a closed document. It should be assumed that this program will be improved and revised later on. Science's complete opinion on this program should be expressed at the Third Congress of Polish Science. During the present term, PAN's most important counseling task will be to present an opinion on an effective economic model for the country for the distant future. This will continue to lead, as heretofore, to the current counseling activity for the government and central organs of administration concerning science and Poland's socioeconomic development. In its frameworks, work is already in progress on, among other things, the general status of carbochemistry in Poland and its development trends, energy raw materials for the chemical industry, improving the effectiveness and rational use of Poland's raw material resources,

the comprehensive use and management of brown coal mining areas in Poland, the management of Poland's fuel and energy resources, the multifunctional management of rural areas, the status of Poland's regional management, evaluating Poland's present administrative divisions and recommendations in this area. In addition, at the beginning of the PAN Presidium term, an expert appraisal program will be developed that is especially important for the entire 1984-1986 term and that will consider key questions concerning the social and economic development of the country. This program should be correlated with the government works program and should take into account the thematic proposals of the Council of Ministers Planning Commission. On the other hand, the expert appraisal program should consider elements of our "own initiatives" regarding science based on the recommendations of the departments, divisions and the scientific committees of the PAN Presidium.

To execute these presented opinion-giver tasks, it also is necessary to expand the direct participation of PAN members in counseling activities.

### 3. The Third Congress of Polish Science

The Third Congress of Polish Science, the organization of which is planned for mid-1985, will be the culminating event in Poland's scientific life during the current term of PAN's administration. The congress is supposed to analyze the status and development directions of science and to evaluate the possibility of science to operate more effectively to overcome existing difficulties and accelerate the country's economic development. Preparation for the congress and its deliberations should provide a plane for a specific working dialogue between science and the government to develop the program and to establish the conditions to develop science in Poland and expand scientific activities based on the analysis of the country's needs. On the other hand, the dialogue should establish the state's ability to realize the planned scientific tasks for the very near and distant future.

The scientific community's attitude to changes in the system to control Poland's science, to the organization of scientific research and cadre training, and to the conditions for applying the results of scientific research and the direction for improving the interlinkage between science and the economy is another important task of the congress. The very idea of a congress arose in 1983, as a result of a dialogue, at a meeting of representatives of the PAN Presidium with the chairman of the Council of Ministers.

In addition to representatives of the scientific community, the Organizing Committee consisted of directors of the central organs of the state administration or ministerial rank. This guarantees that preparations for the congress will take place within the framework of a dialogue between government members and representatives of the scientific community. In addition to pondering the evaluation of the status and direction of scientific research, the congress deliberations, with the participation of Poland's state and political authorities, will be a dialogue between the scientific community and Poland's political and state authorities.

For the scientific community, the congress deliberations will be an occasion to document science's contribution to solving Poland's crisis. Documenting

the real, social usefulness of scientific research will be vital vis-a-vis the climate regarding science's problems and needs. The active participation of PAN's members, scientific committees, departments, divisions and institutions is essential in the preparatory work for the Third Congress of Polish Science.

For the resolutions and opinions of the congress to be approved by Poland's entire scientific community, it is necessary that representatives of all scientific communities participate in the preparatory work and deliberations of the congress. Thus, close collaboration among the PAN, the Ministry of Science, Higher Education and Technology, the higher schools, the ministerial institutions and the scientific associations will be indispensable.

In addition to the contents of its resolutions, the course of the congress and the form of its organization will have an important effect on the public response to the congress deliberations. In this situation, making the deliberations to be of a working nature and very specific, along with an exceptionally modest setting, will be one of the most important organizational tasks of the Third Congress of Polish Science.

#### IV. Guaranteeing the Material Conditions for the Development of Science

##### 1. Guaranteeing Funds for Scientific Research

One of the key tasks before the PAN during the current term is guaranteeing funds for scientific research. A starting point for activities in this direction is to assume that the share of funds for research and development work should amount to about 2 percent of the national income.\* Thus, compared to the present, research and development funds should increase about 65 percent, and funds for basic research should increase by a like amount.

Independent of efforts to increase funds for basic research in the PAN budget, PAN's directors are taking immediate action to obtain additional funds from the Central Fund for Technical and Economic Progress. Another way to obtain additional funds is for PAN's institutions to participate more extensively in solving research problems coordinated by units outside PAN.

##### 2. Supplies of Scientific Research Equipment

An important task for the PAN administration during the present term will be to increase investment funds to prevent the disinvestment of fixed capital stock. It is necessary to increase investment funds by 150 percent compared to present investment funds. In addition to equipment purchases, it is necessary to purchase typographic machines for the printing house. Action will also be initiated to accelerate the completion of started building projects.

In addition to purchasing scientific apparatus and spare parts, another source of supplies for PAN's institutions will be activities to increase the production

---

\* This assumption was discussed in the paper "Nauka Polska Dzis i Jutro" [Polish Science Today and Tomorrow] by the PAN president and PAN scientific secretary at the 9 December 1983 session of the PAN General Assembly.

of scientific apparatus in the experimental plants and enterprises by, among other things, expanding the manufacturing base. Action will be initiated to design and produce apparatus, in cooperation with the academies of sciences of the socialist countries, to a greater extent than heretofore. Action will be taken to develop proposals to control the production of scientific research apparatus on a national scale. Recommendations in this regard will be presented to the state authorities.

During the present term, the modernity and quality of apparatus produced by PAN's enterprises will be evaluated and directions will be outlined to expand production. Action will be taken to introduce new production technology and to standardize and type components. Later on joint action will be taken with design development institutions to a greater extent than heretofore to initiate production of developments by PAN institutions.

Efforts will be made to include within PAN's scientific institutions operations in research work in the area of metrology, scientific apparatus and coordination work in this area.

### 3. Availability of Scientific Literature

The deterioration of the overall conditions for conducting science in Poland, resulting from the crisis and the international situation, makes it all the more important that Poland's scientific institutions be supplied with foreign scientific literature to develop science and to maintain its ties with world science. In view of the exclusive limitations of services for science in the area of equipment, supplies, investments and imported apparatus, PAN's directors will attempt to maintain the supply of foreign scientific literature at least at the 1980 level by barter exchanges and imports. In practice, this will mean that the demand for scientific periodicals and books from the socialist countries will be satisfied completely. This also will mean an annual supply, in absolute numbers, of about 15,000 copies of periodicals and 8,000 copies of books from exchanges and about 4,000 copies of periodicals and 20,000 books from the II payments area.

11899

CSO: 2600/518

POLAND

## POLICY ON PUNISHING OFFENDERS OUTLINED

Warsaw RZECZPOSPOLITA in Polish 15 Feb 85 p 2

[PAP Article: "Greater Efficiency of Punishment; Vice Minister of Justice Tadeusz Skora on Bill on Special Criminal Liability"]

[Text] At its meeting last week, the Council of Ministers examined a bill introducing interim regulations on special criminal liability. The first Deputy Minister of Justice, Tadeusz Skora, outlined the main provisions of the proposed legislation to a PAP correspondent:

Our policy as regards punishing offenders must correspond to the existing crime rate. The recent surge in crimes against citizens and their property, in theft of public property and in profiteering must be countered by balanced, yet severe and consistent punishment. The proposed legislation changes the principles of criminal liability for dangerous violations of law and order, increasing the punishment to make it act as both a deterrent and a means of reeducation.

Firstly, it is planned to restrict considerably the application of conditional reprieve for persons sentenced to imprisonment for offenses listed in the bill.

Briefly speaking, conditional reprieve means that someone receives a suspended sentence, and instead of going to prison is put on probation for a period of several years, as specified by the court. If he does not violate the law during that period, he does not have to serve his prison sentence.

The bill would limit the number of offenders eligible for conditional reprieve. For example, the courts would not be able to suspend the prison sentences of those guilty of crimes endangering the life and health of another person committed under the influence of alcohol, such as assault or participation in an affray with the use of a dangerous weapon, where the victim suffers grievous bodily harm or even dies.

It would not be possible to give suspended sentences to drunken drivers guilty of causing accidents where the victims were seriously injured or died.

This harsher procedure would also apply to those responsible for the most serious offenses against property: burglary, organized theft, robbery, the sale of stolen goods, the theft of road vehicles subsequently abandoned in a damaged condition, and the most serious profiteering offenses.

This change in the application of conditional reprieve is formulated plainly in the bill. Exemptions could be made only in exceptional cases, and only after the damage had been made good in full or, in the case of bribery, when the offense was confessed to law enforcement agencies early enough.

Secondly, the bill on special criminal liability limits the application of special mitigation, i.e. the passing of sentences lower than the minimum envisaged in the penal code.

This will not be applicable to the offenders I've already mentioned. Similarly, save a few exceptions specified in the law, it will not be possible to pass less than the minimum sentence on people found guilty of the theft of public property of considerable value or property carried by the railways; nor of robbery, or of particularly cruel rape.

Thirdly, there has been considerable criticism concerning the size of fines. It is often argued, quite correctly, that a 20,000 zloty fine bears no relation to the proceeds of today's crimes and in the present situation can only be used as a penalty for misdemeanors.

Crime must not pay. The bill therefore stipulates that the fine for theft of public property cannot be lower than the value of the stolen property, and in the event of damage to property, not lower than the value of this damage. Profiteers would be treated even more harshly, with the fine amounting to at least twice the value of the goods involved. Finally, in the case of bribery, those giving and accepting the bribes will be fined at least ten times the amount involved.

Fourthly, for some time now there has been a particularly high incidence of thefts on the railways. Therefore, as suggested by the Chairman of the Government Committee for Law and Order and Public Discipline, the bill lays down harsher penalties for theft of public property in public transport--up to ten years' imprisonment.

If those found guilty of theft in transport are people responsible for protecting or guarding the property concerned, they face sentences from 3 to 15 years' imprisonment.

Fifthly, the bill introduces much broader possibilities for applying additional civil sanctions, especially confiscation of property, in whole or in part, and the publication of sentences in the media.

Sixthly, the bill also amends parole procedures. Habitual offenders would not be eligible for parole. On the other hand, more offenders would be eligible for parole after serving at least half of their sentence, but not less than

six months. Apart from juvenile offenders, this group would now include those convicted of unintentional offenses, where early release is justified by their family responsibilities, i.e. care of children, or age.

Seventhly, the proposed changes also concern penal procedure.

It is planned to make greater use of immediate procedure in cases where the offender is caught in the act or immediately afterwards and is brought before the court within 48 hours of the crime. The list of offenses where this procedure is applicable is to be broadened considerably. This procedure would apply nationwide, not only in some towns or voivodships as is the case at present. The court would be empowered to sentence offenders to up to three years' imprisonment and fine them up to 500,000 zloty. At present the maximum is one year's imprisonment and a 25,000 zloty fine (or two years and 100,000 zloty in the case of profiteering offenses).

The bill also envisages the introduction of so-called court order procedure. This would free the courts from many trial procedures, often time-consuming ones, in cases involving relatively less dangerous offenses. A district court represented by one judge would be able to issue a court order without holding a trial in the cases of offenses punishable by restriction of personal liberty or a fine. I should emphasize that this applies to cases where the established evidence leaves no doubt as to the guilt of the accused. The court order could involve restriction of personal liberty, a fine and additional sanctions such as a ban on holding particular posts or carrying out particular jobs, suspension of a driving license, or publication of the verdict in the media.

Barring an objection submitted by any side, the sentence contained in the court order would be subject to execution, on the same principles as a normal sentence which is no longer subject to appeal.

The law on special criminal liability would be an interim one, in force for a strictly defined period of time. There is no need to amend penal law permanently in such manner. The temporary introduction of harsher penalties should make punishment of offenders more effective at a time when the crime rate is high.

CSO: 2020/83



BRIEFS

NEW TRADE UNION--The Voivodship Court in Warsaw on 27 February registered the Federation of the Trade Unions of the Home Defense League Workers in Warsaw. This is the 129th all-Polish trade union organization existing in law. [Text] [Warsaw TRYBUNA LUDU in Polish 28 Feb 85 p 2 AU]

MOKRZYSZCZAK WITH ZYCIE PARTII--Wlodzimierz Mokrzyaszczak, PZPR Politburo candidate member and Central Committee secretary chaired the session of the Editorial Council of the PZPR organ ZYCIE PARTII to discuss the council's activities in 1984 and the plans for the organ. [Summary] [Warsaw ZYCIE WARSZAWY in Polish 1 Mar 85 p 2 AU]

MESSNER WITNESSES ACCORD SIGNING--The Economic Academy in Katowice and the Ministry of Mining and Energy signed a cooperation accord on 28 February. The academy will help solve the economic problems of the coal industry and the academy's scientific staff will act as advisors and consultants. The signing was witnessed by Zbiniew Messner, PZPR Politburo member and vice premier. [Text] [Warsaw SZTANDAR MLODYCH in Polish 1/3 Mar 85 p 2 AU]

KALKUS IN POZNAN--PZPR Politburo member Stanislaw Kalkus attended the pre-19th Central Committee Plenum session in the Cegielski plant in Poznan to discuss the basic job problems of the industrial intelligentsia. [Summary] [Warsaw ZYCIE WARSZAWY in Polish 2/3 Mar 85 p 2 AU]

KUBIAK IN KRAKOW--PZPR Politburo member Hieronim Kubiak attended the plenum of the PZPR Voivodship Committee in Krakow, which agreed that the party's presence in all communities had become even more important and authoritative in the past 2 years. [Summary] [Warsaw ZYCIE WARSZAWY in Polish 2/3 Mar 85 p 2 AU]

GLOWCZYK IN LODZ--Speaking at the Lodz journalist meeting devoted to the role of the Polish intelligentsia, Jan Glowczyk, PZPR Politburo candidate member and Central Committee secretary, stressed that the differences between the workers class and the intelligentsia had disappeared to a great extent in the past 40 years. [Summary] [Warsaw ZYCIE WARSZAWIN Polish 2/3 Mar 85 p 2 AU]

SOVIET TU DELEGATION VISITS--A delegation of the Soviet Trade Union activists, led by Vladimir Sergejev, head of the International Department of the AUCCTU, visited Warsaw at the invitation of the All-Polish Trade Union Congress and had talks on the 1985 cooperation plan and on the joint plan for celebrating

the 40th anniversary of the 1945 victory. The delegation was received by Tadeusz Porebski, PZPR Politburo member and Central Committee secretary. [Summary] [Warsaw TRYBUNA LUDU in Polish 5 Mar 85 p 2 AU]

SOVIET EDUCATION DELEGATION VISITS--A delegation of the Soviet Ministry of Higher and Secondary Specialist Education, led by First Deputy Minister Nicolai Krasov, studied the research and experimental work of the Lodz Polytechnical Schools on 28 February. The delegation met with Tadeusz Czechowicz, PZPR Politburo member and first secretary of the PZPR Committee in Lodz, and with Lodz administrative authorities. The sides discussed scientific cooperation based on the opportunities provided by the higher education schools in Lodz. [Text] [Warsaw TRYBUNA LUDU in Polish 1 Mar 85 p 2 AU]

HUNGARIAN TU OFFICIAL VISITS--Karoly Slowacsik, head of the Hungarian Central Trade Union Council Foreign Department, paid a working visit to Warsaw at the invitation of the All-Polish Trade Union Congress and had talks with the leaders of the congress and with the officials of the PZPR Social and Vocational Department. K. Slowacsik was received by Tadeusz Porebski, PZPR Politburo member and Central Committee secretary. [Summary] [Warsaw TRYBUNA LUDU in Polish 2/3 Mar 85 p 6 AU]

JARUZELSKI RECEIVES SPD'S EHMKE--PAP--On 5 March, Army General Wojciech Jaruzelski, PZPR Central Committee first secretary, received Horst Ehmke, deputy chairman of the SPD faction within the Bundestag, who is visiting Poland to take part in talks by a working group from the PZPR and SPD on the building of mutual confidence measures. The activity of both parties for the sake of normalizing and developing PPR-FRG relations was discussed. It was stated that an improvement in these relations may improve the political climate and strengthen security and peace in Europe. Josef Czyrek, PZPR Politburo member and Central Committee secretary, also took part in the talks. [Text] [Warsaw RZECZPOSPOLITA in Polish 6 Mar 85 p 1 AU]

NEW EDITOR OF TU I TERAZ--On February 18, a meeting was held to bid farewell to the editor of TU I TERAZ, Kazimierz Kozniewski, who is going into retirement. Bogdan Jachacz, the head of the PZPR CC's Press, Radio and Television Department, and Alina Tepli, the vice-chairman of RSW publishers, thanked Kozniewski for many years of dedicated work in Polish journalism, and especially for his civic commitment in recent years. Klemens Krzyzagorski, the chairman of the Journalists' Association of Poland (SD PRL) and previously editor of PRASA POLSKA, has been appointed the new editor-in-chief of TU I TERAZ. [Text] [Warsaw TRYBUNA LUDU in Polish 19 Feb 85 p 2]

EXECUTIVE PROGRAM WITH INDIA--The Executive Program of the Polish-Indian Agreement on Cooperation in the Peaceful Utilization of Atomic Energy has been signed in Delhi. This is a result of the decisions taken during Wojciech Jaruzelski's visit to India. [Text] [Warsaw Television Service in Polish 1620 GMT 7 Mar 85 LD]

CSO: 2600/693

ROMANIA

ROUNDTABLE ON STAGES , CONTINUITY OF REVOLUTIONARY PROCESS

Bucharest ERA SOCIALISTA in Romanian No 21, 10 Nov 84 pp 26-38

/Discussion by Dr Marin Badea, Univ Lecturer Dr Angela Banciu, Univ Reader Dr Olivia Clatici, Univ Reader Dr Viorel Cornescu, Univ Prof Dr Constantin Enache, Pamfil Nichitelea, Univ Prof Dr Petru Panzaru, Univ Prof Dr Ion Rebedeu, Dr Constantin Stroe, Dr Gheorghe Surpat, Univ Prof Dr Ion Tudosescu and Univ Prof Dr Ilie Vaduva

/Text As Nicolae Ceausescu said, "We must always bear in mind that the revolutionary process and the revolutionary struggle are not over. They are continuing under the new historical conditions. It is the RCP's great responsibility to inspire the entire people's revolutionary fighting spirit, to lead the Romanian nation under the new historical conditions, and to secure the triumph of communism in Romania."

The theory of the continuity of the revolutionary process and its elevation to ever higher and superior levels is a main feature of the RCP's theoretical, ideological and political thought. In this view the stages of the revolutionary process and efforts in Romania are an uninterrupted succession of phases that are distinct but in a close unity and interdependence, each of them built upon the foundation of the progress of the preceding ones and attaining higher goals in its turn.

Since the Ninth Party Congress especially, Romania has undergone an accelerated and vigorous socioeconomic, political and cultural development, fully validating and constantly enhancing the revolutionary, innovating trend that the party secretary general and president of the republic has lent the whole undertaking of building the new social order. Nicolae Ceausescu's telling contribution to the determination and implementation of the general party policy, the realism and scientific perception with which the party and state leader approaches the essential problems of Romanian society's development, the soundness of the options and the boldness of the measures recommended on the basis of constant comparison of revolutionary theory with social practice have given a new impetus to theoretical thought, to political-ideological work and to the masses' creative effort to carry out the great RCP Program for Building the Fully Developed Socialist Society and for Romania's Advance Toward Communism as well.

In this connection, the Draft Directives of the 13th Party Congress forecasting Romania's development in the 1986-1990 Five-Year Plan and henceforth up to the year 2000 open up new and bright prospects for bringing Romania up to ever higher levels of progress and prosperity. These inspiring goals lend new dimensions to the revolutionary reform of Romanian society and indicate even more emphatically the necessity of maintaining the militant revolutionary spirit in all activities. As Nicolae Ceausescu strongly emphasized in his Harvest Day speech in Slatina, "It must be understood that in order to bring about these splendid prospects and develop Romania we must always live and act as revolutionaries, realizing that the revolution we began when the working class and the people seized political power under the communists' lead has made great progress, but it is still going on and and it will have to be brought up to a higher level."

This revolutionary and profoundly scientific conception of socialist social development presents a number of theoretical and practical problems demanding greater efforts to investigate and study the new phenomena and processes in depth for purposes of clarifying their many implications in order to succeed in the great undertaking of socialist and communist construction in Romania. To meet those demands, ERA SOCIALISTA arranged the following discussion, of which we are publishing an abridged stenographic record.

#### Revolution and the Revolutionary Process

PETRU PANZARU: Socialism, a social system evoked by history as a better and truly humanistic solution to the antagonistic contradictions and abuses of the rule of private property and the exploiting classes, is instituting a new dialectic of socioeconomic, political, ideological, cultural and human development.

The theory of the founders of scientific socialism, Marx and Engels, already formulated in the "Manifesto of the Communist Party," that it is the historic mission of the proletariat to turn the bourgeoisie out of power by revolution, to "expropriate the expropriators," to socialize the main production means, to bring harmony between production relations and the productive forces, and to begin building a radically new social system, has been fully vindicated by history. From a "utopia" and then from a stage of planning and prediction, socialism has become an irreversible historical reality shaped by the various socioeconomic and specific-historical political conditions of the many peoples and nations.

It would have been foreign to the spirit of the historical-materialist dialectics that they founded for Marx and Engels and Lenin later to prescribe formulas or recipes for the revolutionary process and socialist construction in each and every country. By regarding Marxism in general and the socialist revolutionary theory in particular as guides to action and not as a collection of immutable truths, the RCP and its secretary general have enriched the treasury of scientific socialism with new theories and conclusions based on experience in building the new society under particular internal and international historical conditions.

One of these theories, abundantly substantiated in Nicolae Ceausescu's works, concerns the continuity of the revolutionary process in Romania as a reflection of creative application of dialectical and historical materialism to the Romanian situation.

GHEORGHE SURPAT: Previous historical experience tells us that construction of the new order is a very far-reaching revolutionary process running through several stages regularly succeeding each other in accordance with each country's conditions and necessities. Experience has disproved the simplistic idea, formerly expressed in the social-political literature, that construction of the new social order would be of short duration and confined to the period of transition from capitalism to socialism.

Socialism and communism are new and higher types of society, and their construction is a continuous revolutionary process taking place under historical, national and social conditions that differ from one country to another and from one stage to another, so that the revolutionary process of socialist and communist construction is a dialectical unity of the general and particular in each country. Experience in building the new order in Romania and in other countries as well demonstrates the unity of this process in all its essential aspects as well as the diversity of the options, ways and means, and experience in building socialism, refuting the restrictions to a "single way" or "single model" of socialism. The RCP regards any form of socialist construction going on in any country as authentic and suited to the historical necessities.

In pointing out the far-reaching and protracted nature of the revolutionary process of socialist and communist construction, the party secretary general has repeatedly warned us of the danger of a voluntarist interpretation or idyllic view of socialist construction. Any such view would prevent arming the communists and workers with the firm will to overcome any difficulties and to secure Romania's continued social and economic progress. As Nicolae Ceausescu says, "The revolutionary process and the socialist revolution are still going on and must be developed in accordance with each historical stage, both in the case of the productive forces and in those of changes in the socialist structure, social and production relations, social management, and the way of life. The revolutionary process will continue and will be very pronounced throughout the whole task of building socialism, the fully developed socialist society, and communist society."

As the party secretary general pointed out at the Expanded Plenum of the RCP Central Committee in June 1982, at the National Party Conference in 1982, and at the Mangalia Working Conference in August 1983, from this standpoint and in pursuance of those main guidelines it is particularly important to construction of the new social order to define the stage of socialist construction correctly in every new stage of the revolutionary process as well as the stages reached in economic development, in evolution of the social structure, in formation and improvement of the new superstructure, and in formation of advanced awareness, because it is on that basis that the practical measures necessary to implement the aims of socialist and communist construction are determined and approved. Accordingly the Draft Directives of the 13th Party Congress forecast the main directions of the nation's development in order to make it possible, in the next period, to begin achieving the higher stage of socialist society and building communism in Romania.

ION REBEDEU: The idea of continuity of the revolutionary process is based on the premise that socialist construction and transition to communism are a lengthy process of radical and comprehensive revolutionary changes and accordingly throw a bold, productive and innovating light upon the treatment of all problems,

economic, political, cultural, educational etc., presented by construction of the new order in Romania. I do not think either the basis or the content and meanings of the theory of continuity of the revolutionary process can be properly understood without considering the important and significant elements which, in the years since the Ninth Party Congress, a historic turning point in Romania's whole development, have lent substance, distinctness and a profound originality to the RCP's conception of socialism within the general framework of the Marxist theory and scientific socialism.

The "economistic" view of socialism (including the narrow, mathematical approach of the economist himself, reducing it to development of the productive forces alone) is quite foreign to the RCP's conception. Moreover the strategic objective of building the fully developed socialist society is conclusive in that regard. In accordance with the policies formulated at the Ninth Party Congress, enriched in theoretical substance and social receptiveness by Nicolae Ceausescu in the following years, Romanian socialism has acquired new and significant trends that give it both a distinctive character of its own and the framework of the dialectical processes of revolutionary innovation in all economic and social activities and structures. I would mention here such trends as development and enhancement of revolutionary socialist democracy; provision for social management by the people; consolidation and prosperity of the Romanian socialist nation; complete unity of the entire people's interests, ideals, will and action; promotion of revolutionary humanism; formation of the new man; application of the principles of socialist ethics and justice in practice, etc.

The process of constructing socialism's system of values also has a profoundly revolutionary character. Promotion of those values, which are shaping socialism politically, morally, culturally etc. now and in the future, was well as their implementation in the human community, are extremely complex revolutionary tasks. To this end, promotion of socialist humanism and implementation of the series of principles and standards that form the humanistic ideal of the new order call for a prolonged effort, a revolutionary spirit, perseverance and a sustained effort to keep improving the institutions' activity in socialist society so that they will operate in full accord with the new socialist system of values. I believe all this even further illustrates the profoundly revolutionary nature of the present stage of Romanian society's development and the continuity of the revolutionary effort throughout the whole process of socialist and communist construction.

MARIN BADEA: I feel the scientific, dialectical interpretation of the relationship between revolutionary theory and practice is highly important in explaining the profound significance of the theory of continuity of the revolutionary process in Romania. Accordingly I should like to point out first of all some characteristics that I consider definitive of the RCP's thought and action, such as its constant effort to determine the realities and historical facts thoroughly; its active receptiveness to the changes in the continuous process of the real historical movement and its ensuing perception of that which is new and progressive and representative of the actual direction of development; its continuing comparison of views and of its own experience with that of others and other opinions expressed on the broader level of contemporary discussions, without preconceived ideas and as de from the former practices wherein labeling was often an "argument"; and its rejection of subjectivism and superficiality, simplistic and one-sided theories, and outmoded ideas and principles applied in a certain stage but refuted by social-political experience.

This approach has proved quite constructive and alone able to facilitate the realistic treatment of contemporary phenomena and the efforts to find the most effective solutions to the highly complex problems of socialist construction. As the party secretary general has often said, the success of the revolutionary effort to build socialism and communism heavily depends upon every party's ability to approach Marxist thought and the ideas of scientific socialism without prejudices, to add their own creative and original notes to their theoretical and practical work, and to meet the demands of social-political practice with appropriate answers. Nicolae Ceausescu pointed out to this effect that "Theoretical work should give the party a clear perspective on social evolution and answer the questions that arise in social activity both nationally and internationally. In other words it should light the way for the actual practice of building the new order. That is the only way theory will help the party to develop its political policy and to form a clear, scientific conception of the tasks and objectives of each developmental stage of socialist and communist society."

OLIVIA CLATICI: Actually the theory of continuity of the revolutionary process is not only a contribution of inestimable theoretical value but also a broad, innovating approach to social-political practice and to the vast effort devoted to construction of the fully developed socialist society and to the advance toward communism which, as it has been said here, is bringing the revolutionary process up to higher levels. This idea was very heavily emphasized at the Mangalia Conference in 1983, where the party secretary general pointed out that we must always bear in mind the fact that "The revolutionary process and the revolutionary struggle are not over but are continuing under the new historical conditions."

I think some conclusions are to be drawn from this.

First, we have to deal with an original contribution to the interpretation of the idea of revolution, which is not envisaged as one single act nor confined to the overthrow of the oppressor classes and acquisition of political power. As Nicolae Ceausescu said, "That was only one stage -- a vital one to be sure, but only one stage of the revolutionary struggle. It may be said that the following stages were no easier but, on the contrary, they were even more difficult than the battle for power, because they required intensive preparation and great revolutionary changes in the whole society." Clearly under those circumstances a narrow, simplistic view of the revolutionary process would be foreign to Marxist thought and the nature of the socialist revolution, which is a lengthy process involving extensive and continuous economic, social-political and cultural changes, restructurings and improvements and the formation of a new and higher type of civilization as basic objectives that are achieved in an organized and planned fashion under the leadership of the revolutionary party of the working class.

Second, in the light of the concept of continuity of the revolutionary process we find socialism and communism themselves always perfectible and dynamic in the sense that the socialist content of society and, in the future, its communist content are actually subject to constant renovations, improvements and adjustments to meet the requirements of each historical stage.

And third, I think the continuity of the revolutionary process calls for firm departures from outmoded situations or breaks, I would say, with all that is

opposed to progress, a shift to a new and better quality, and ultimately a permanent revolutionary state of mind for all society, aware that it must outdo itself and commit itself more and more actively to the battle for the new and for progress. I feel this process of constant improvement of Romanian society must be clarified in all its aspects and implications because it is a matter of improving not only society as a whole but also the workers collectives, their organization and activity and especially, I would say, the individual's existence, his behavior and his actions. I would stress this point particularly because some members of society still display a certain love of routine, a certain resistance to innovations or, conversely, tendencies toward false innovations. Perhaps from this standpoint a more penetrating analysis would be needed of what objectively necessary innovations of a revolutionary nature mean to socialist society.

The continuity of the revolution is accordingly a dialectically necessary and objective process. It is not taking place evenly of course, with no difficulties or contradictions, but requires a firm, determined effort to overcome any obstacles and difficulties, a revolutionary spirit in all activities, a high sense of responsibility on the part of all members of society, and complete coordination of each one's actions with the interests and requirements of general social development.

ION REBEDEU: Accordingly the qualitative innovations in all fields are being introduced through the masses' direct and active participation and the purposeful effort of the entire people guided and inspired by the party's enterprising and revolutionary policy and the programs for national socioeconomic development aimed at new revolutionary qualitative innovations in the economy as well as in culture and in social relations as well as in training the labor force. From this viewpoint, continuity of the revolutionary process does not mean just the legitimacy of the innovations and changes that can lead to the fully developed socialist society but also, and in a complete identity, the necessity of changing people's awareness and their way of thinking and acting and of their responsible involvement and purposeful participation with patriotic perseverance and a revolutionary spirit in the accomplishment of these innovations, which ensure the nation's continued development, progress and prosperity.

In the RCP's widely receptive democratic and humanistic view, the people are primarily the subjects of all revolutionary reforms. Therefore it follows that the revolutionary spirit should be a constant, ceaselessly enriched and revised, of the thoughts, feelings and actions of the masses of workers and particularly of the communists of course. This unquestionably makes it necessary to boldly overcome any phenomena, attitudes or situations that make for stagnation or unrest.

PETRU PANZARU: In the RCP's dialectical view, continuity does not mean strict adherence to the one revolutionary process that has brought Romania to the stage of building the fully developed socialist society. In the course of that process, thanks particularly to the dynamic, creative policy inaugurated by the Ninth Party Congress and consistently maintained and enriched thereafter by the party's congresses and national conferences characterized by Nicolae Ceausescu's innovating thought, there have been improvisations that inevitably led to qualitative leaps in all areas of society, especially in the economy, and made it possible to formulate some new and more far-reaching objectives.



As we know, Romania's transition to a new developmental stage and a new quality of work and life in all fields are the main objectives of the new stage. Essentially it is a matter of creating a new socioeconomic and human reality and a new man imbued with the ideals of socialism and behaving in a consistently revolutionary, innovating and creative way. The provisions of the Draft Directives of the 13th Party Congress are significant in this respect, emphasizing as they do the qualitative factors, high efficiency, complete exploitation of the possibilities and reserves of the socialist economy, and achievement of a real leap in the vital field of social labor productivity, intensified by application of the advances of the technical-scientific revolution and improvement of the masses' standard of culture, knowledge and socialist awareness.

The objective dialectics of the continuity and discontinuity (qualitative leap) of the single revolutionary process, implemented under the party's leadership, are spurred by the purposeful acts of perception and adequate resolution of the contradictions and lags in any given sector (for example, the lags in ideological and political indoctrination behind the advanced state of the productive forces) and by the powerful stimulus of the new in conflict with the old both in practice and in social awareness. The RCP secretary general has repeatedly pointed out that resolution of contradictions and the conflict between new and old are attributes of the party's leadership and the objective basis for further consolidation of its role as vital center of the socialist nation.

MARIN BADEA: I think the careful analysis of the dialectics of society, and of principles and laws governing the revolutionary process, that the RCP and its secretary general have made is important for bringing out the continuity of the revolutionary process in Romania, for breaking with all that is outmoded and obsolete, and for the beginning of a new and higher quality. By rejecting the dogmatic ideas of the new order that minimize the conflict of opposites in the evolution of socialist society, the RCP has enhanced its analysis of the content and direction of the historical movement and of its contradictory nature, which appears as such even in socialism. As the party secretary general says, "Experience abundantly proves that contradictions still exist and even new contradictions arise in socialist society too." This not only reinstated one of the main elements of materialist dialectics, namely the objective and universal character of contradiction as a source of the movement, but also made it possible to enrich the analysis of other principles and theories as well, such as for example the dialectical correlations between subjective and objective, general and particular, and national and international in the revolutionary process of building the new order.

Without going into the analysis here of the various contradictions in the present stage of socialist Romanian society's development that was so masterfully made in the Report to the National Party Conference in December 1982 and in other speeches of the RCP secretary general's as well, I would like to point out only the fact that the originality of the RCP's conception of the dialectics of the process of socialist construction and its effort to investigate and expose the contradictions in that process strikingly reflect the revolutionary nature of Romanian socialist society's development.

OLIVIA CLATICI: Furthermore the very nature of the revolutionary process is contradictory. While innovations, revolutionary reforms and "breaks" with what

is outmoded are constantly going on, a process is in progress of consolidating the new situations and the new quality against the background of the stable socioeconomic system as a whole. I believe the dialectical relationship between new and old and between continuity and discontinuity also requires a state of equilibrium and stability wherein the continuous revolutionary reforms are articulated. Of course the process calls for careful checking and understanding because, among other things, complete assimilation of socialism's new set of values in its main characteristics has not yet become a consolidated reality for some members of society. I think a clear understanding of the objective requirements for social progress at a given time, of the necessity of the changes, and of their purpose is both a prerequisite and a requirement for maintaining the revolutionary spirit.

I would also note that the revolutionary process in its continuity requires qualitative accumulations that consolidate and develop the previous accumulations, while it goes without saying that the "breaks" we were discussing are acts of rejecting and overcoming what is old and obsolete. But they are among the socialist realities and accordingly require no structural changes whatever in the nature of the system as a whole but only improvements and changes in the existing social structure. I think these aspects present a broader theoretical problem of interpreting the nature and character of the socialist revolution.

PAMFIL NICHITELEA: On the other hand, as we know, the concepts of socialist revolution and socialist construction are still definitely in use, and I think the continuity of the revolutionary process throws a new light on this question too.

ION TUDOESCU: I feel the question raised here is one of the meaning of a basic concept of historical materialism, namely that of social revolution. In the light of its classic Marxist interpretation, which has been fully borne out by revolutionary experience, the concept refers to the process of radical structural changes in society, which process corresponds to the point of discontinuity in the society's evolution. A social revolution strikes down some social structures and the whole system of social relations and imposes new structures and a new and better arrangement of the economy, the social system and its organizational, political and ideological structures. The bourgeois-democratic revolutions, the socialist revolutions of our time, and all previous revolutionary movements have been seen and defined from this point of view.

Some researchers have concluded from this that the revolution and socialist construction ended the period of social revolution and that henceforth there is no regular (or even logical) ground for discontinuities or revolutionary reforms in society's evolution. But previous practical experience does not in the least indicate that revolutionary changes are no longer taking place in the socialist system, that the idea of revolution is therefore no longer operational in that respect, or that socialism automatically excludes discontinuities in social evolution. Therefore we have to consider the possibility of enriching the concept of revolution, or rather of redefining its present meanings.

OLIVIA CLATICI: The concept of social revolution has, I believe, two meanings, one that of acquisition of power by the working class and a change in the nature of the former power, and the other that of a period of radical economic, social, political and cultural changes, reorganizations and improvements instituted once

power is gained. I do not believe there is any succession of several revolutions but one continuous process in various stages.

PETRU PANZARU: Until recently the expression "revolution and socialist construction" was at least tacitly taken to mean that once power was gained the revolutionary process had essentially attained its objective and another process followed with another content, that of socialist construction. But experience in building the new order in Romania makes it clear that they are only phases or stages of one transforming process that is always of a profoundly revolutionary nature.

The fact that the socialist revolution passes through several objectively determined and necessary stages does not warrant the artificial partition of this single transforming process or the attribution of different meanings to the concepts of "revolution" and "revolutionary process," the first reserved for the struggle for political power and the second for the struggle to consolidate it and attain the ends of socialist construction. In this connection, Nicolae Ceausescu pointed out the objective fact that the revolutionary struggle is not over as soon as the exploiting classes are dislodged and power is gained but continues under the new historical conditions. Accordingly the socialist revolution is not "somewhere in the past." It has not completed its mission but goes on in new forms and with more far-reaching and more difficult objectives and, as we said, an eminently constructive character.

The concept of socialist revolution has been continually enriched by the RCP, lending it a challenging purpose. It does not mean just the period of the "battle at the barricades" to do away with the exploiting classes and shatter the repressive bourgeois state organization but also the long and difficult period, not without contradictions, of basing all socioeconomic, institutional and intellectual activity on socialism and the period of intensive and balanced development of the productive forces as well as that of formation, development and assertion of the revolutionary humanistic values of socialist awareness.

The radical character of the changes in social existence, the economic base, social awareness and the entire superstructure (required for complete achievement of the aims of the fully developed socialist society) is so great and strong that it is obviously of a revolutionary nature and demands a perpetual revolutionary spirit promoting the new and fighting petrification, conservatism, routine and complacency.

In theory and in social practice as well I think the idea and action of continuity of the revolutionary process must be inseparable from rejection of the superficial, idyllic and Utopian picture of automatic and rapid accomplishment of the aims of socialist society without contradictions or very great difficulties. The fact that socialist society is opposed in all respects, from its economic base and political organization to the type of ideology, culture and social awareness that it promotes, not only to the bourgeois system but to all systems based upon exploitation and oppression of the majority indicates the difficulty, complexity, profoundly revolutionary nature and relatively long duration of the process of building the new society.

## Stages of a Single, Continuous Process

ION TUDOSESCU: I do not think a social revolution should be viewed solely as a period of qualitative changes throughout a whole social system or solely as the period of transition from an old order to a new and better one quite different (in all its components, determinisms and structures) from the one it has supplanted. On the contrary (in a sense), the idea of revolution is also operative within the same system and within the same order marking, among other things, the transition from one stage to another in the development of that same order.

Considering in this light the changes taking place in Romania in the present stage, we are fully justified in concluding (bearing in mind that processes of very profound and far-reaching qualitative change are going on in this stage) that the idea of revolution is very important in the strategy for Romania's entire social and economic development. Moreover the party documents and Nicolae Ceausescu's speeches and explanations quite rightly define this stage (of building the fully developed socialist society) as a stage of radical revolutionary changes and of transition to a new and higher quality in all social activities and on all levels of the Romanian social system.

I think at least one methodological point must be kept in mind here, namely that continuity and discontinuity are closely interrelated in the mechanism of the contemporary revolutionary process, as well as the evolutions (increases) at high rates and the qualitative changes in great revolutionary depth that close one stage and open another in the same continuous revolutionary process. All this goes on while the organizational structures of the society are not changed but continually improved, the subjective factor of accelerated social evolution remains the same, but the strategy and tactics are purposefully changed.

Undoubtedly such an interpretation of the dialectics of society calls for some model release on the theoretical level and (Why not?) some conceptual change. For example, the term "revolutionary process" is used to refer to the macrosocial qualitative changes taking place in the present period in socialist countries and, to a certain extent and within certain limits in developed or less developed capitalist countries. I think this is because evolution is not separated in time from revolution, or continuity from discontinuity. This is quite correctly said of the fact that the continuity of the revolutionary process is taking effect regularly in the present stage.

Those are only a few of the reasons why I think we should operate with the idea or concept of revolution in the strategy for building the fully developed socialist society, with the qualification that we are using the term "revolutionary process" to cover the current meanings of this concept in order to forestall any possible confusion. In any case I would stress the point that this term implies revolutionizing not only the main sectors of society but also the human condition and the processes of human fulfillment, and that exactly corresponds to the purposes implicit in beginning to create in this stage the conditions that will help to activate the principles of communism in the next stage.

NITA DOBROTA: I believe we can better clarify the problem raised in the discussion if we analyze the stages in the process of building the new order in Romania.

The RCP considers it of great theoretical and practical importance to schedule the process of socialist construction correctly in accordance with each country's particular conditions and the nature of the period (the world revolutionary process and the general developmental trend), because delimitation of the qualitative stages of the continuous revolutionary process permits in-depth study of the content of each of these stages and facilitates formulation of its characteristics and its place in history. Furthermore knowledge of the content of a stage is essential to setting its strategic goal and correlating the latter with the tasks of past and future stages, and to the most efficient mobilization of the social forces.

In this vast theoretical-methodological undertaking one operates with many criteria, among which I believe the following are the most important and have broad applications: the social-political content, the degree of development and maturity of social relations, the nature and function of the state, the levels of the productive forces and economic development, the sectorial structure of the national economy, the depth of the social division in direct correlation with the preceding criterion, the content and strategic objectives of the developmental policy, etc.

The RCP and its secretary general have applied these criteria strictly and consistently in their interpretation of the main stages of Romania's socioeconomic development in the years of socialist construction. I would stress this point particularly because, as we know, the following scheduling of the historic task of socialist construction and transition to communism has predominated for a long time in Marxist thought and has been considered generally valid at times: completion of the bourgeois-democratic revolution, construction of the economic base of socialism, completion of socialist construction, construction of the bases of communist society and later of full communism.

In the light of the foregoing criteria, the RCP documents point out that the continuous revolutionary process started in Romania by the victory of the Anti-fascist and Anti-imperialist Revolution for Social and National Liberation on 23 August 1944 has gone through several stages, namely the stage of the people's democratic revolution, whose antifascist, anti-imperialist, democratic, antifeudal and, partially, anticapitalist objectives were generally accomplished between 23 August 1944 and 30 December 1947; the stage of socialist revolution, triumph of socialism in city and village, and achievement of the uniform socialist economy, whose strategic task was accomplished by the fulfillment of the 1961-1965 Five-Year Plan; the stage of consolidation of socialist society and especially consolidation of its technical-material base (1966-1970 Five-Year Plan); and the stage of building the fully developed socialist society and of the advance toward communism.

Under the RCP's leadership the Romanian people have made epochal progress in general national development in the last four decades and especially since the Ninth Party Congress. In a brief historical period Romania passed through several historical stages and started to build the fully developed socialist society.

As the party secretary general pointed out at the Solemn Session on the 40th Anniversary of the Revolutionary Act of 23 August 1944, "It can be safely said that in the Romanian people's long history of over 2,000 years, during which they went through many difficult and important stages, the era of these 40 years is the most magnificent and prosperous one in their entire social-historical development."

This era of great revolutionary reforms permanently eliminated capitalist-landowner ownership of the production means and class exploitation and oppression and created a uniform socialist economy in industry and agriculture based upon the workers' joint ownership in the form of ownership of the entire people and upon cooperative ownership of the production means, and the socialist principle of distribution of the social product and national income was applied on the principles of ethics and justice of the new order. Accordingly the productive forces were intensively developed and Romania became an industrial-agrarian country with a modern industry and a developed socialist agriculture in full progress.

OLIVIA CLATICI: The period immediately following the Ninth Party Congress was one of consolidation of the socialist production method and of the socialist system as a whole. A number of vital problems were solved in this period, such as eradication of the old narrow dogmatisms from theory and practice, correction of the distortions, errors and shortcomings of previous years in various activities, development of an original conception of a socialism in keeping with the particular Romanian conditions and its implementation in practice.

ION REBEDEU: The distinctive elements of the fully developed socialist society in their general lines, reflecting an original view of socialism, were already formulated in the Report to the Ninth Party Congress. That historic document brings out ideas that were to be developed and treated in depth in the subsequent party documents and in Nicolae Ceausescu's extensive theoretical works. I refer, for example, to the problems of democracy and socialist awareness, the delimitation of the simplistic and dogmatic views of the nature of socialist society, etc. Without doubt the question may be raised as to the existence of several stages within the historic period of 1965-1984, but I think we must also bear in mind that there are many substantive elements common to all these stages and to the last two decades of rapid, unprecedented development of Romanian society.

VIORREL CORNESCU: The opinions and conclusions formulated by Nicolae Ceausescu concerning the stages of the revolutionary process since 23 August 1944 are based on a comprehensive scientific analysis of the course taken by Romania during the years of socialism, wherein notable economic, political, social and cultural progress has been made.

As we know, at the start of the socialist revolution the Romanian economy was underdeveloped, having an unbalanced sectorial and geographic structure backward technical-productive potential, and heavily dependent upon the international monopolies interested in keeping it an agrarian annex and a supplier of raw materials. Accordingly, once the working class in alliance with the working peasantry and the other categories of workers had gained political power, action was taken under the party's leadership to develop the productive forces intensively and thereby reform the structure and character of the Romanian economy. The great progress made in that direction and the formation of a modern and dynamic economy would have been impossible without consistent implementation of the socialist industrialization policy.

The major aims of the Ninth Party Congress marked an essential turning point in the policy of industrialization and of general economic development on that basis. They made it possible to form an original concept of national industrialization, a concept including as main elements increasingly efficient use of material, financial and human resources, intensive growth of labor productivity, priority development of the advanced processing sectors, the peak sectors for technical progress, manufacture of highly technical products of better quality, industry's increased contribution to development of agriculture as well as the other economic sectors on a modern technical basis, etc.

National industrialization was the most important element in the strategy for economic development, to be sure, but it was not the only one. Romania's accelerated development was and is also based on the party's own original conception of development and structuring of the economy to meet the demands of long-term social progress as well as those of each developmental stage. The efforts based on this strategy were directed so that a balanced national economic complex could be achieved in a relatively short time, harmoniously combining industry with agriculture, the extractive sectors with the processing ones, the sectors producing production means with those producing consumer goods, etc. All this accelerated development of the productive forces, increased the economic strength of the nation, and brought about extensive changes in the Romanian economy's performance and structure that led to Romania's conversion in a brief historical period into an industrial-agrarian state with a modern and continually developing industry and a socialist agriculture in full course of modernization as well as an increasingly high level of material and cultural civilization.

Very profound principles of exceptional theoretical and practical value for the direction of Romania's socioeconomic development have been developed in recent years at Nicolae Ceausescu's suggestion and with his telling contribution. The Draft Directives of the 13th Party Congress provide a vast program of socioeconomic development for the new five-year plan, focused on the shift from extensive to predominantly intensive development and further emphasis upon all qualitative factors. This will invigorate the national economy intensively, modernize its structures, develop all sectors proportionally, and strike an optimal balance among the various sectors of the economy in order to best meet the needs of productive and individual consumption and steadily increase the national income.

GHEORGHE SURPAT: The people's democratic revolution, the socialist revolution and construction of the foundations of socialism, the consolidation of the new order, and the start of construction of the fully developed socialist society are so many stages of the one revolutionary process of socialist construction in Romania, indicating the continuity of that process and its features peculiar to each stage.

Construction of the foundations of socialism, abolition of ownership based on exploitation of man by man, and achievement of a society of social and national equality, all historic victories of the Romanian people led by the RCP, created the objective economic and social conditions to bring the Romanian revolutionary process up to a new and higher level. Of course creation of those conditions did not solve all the problems of complete implementation of the socialist principles in all social activities. As it has been said here, a vital part in directing the Romanian people's efforts to that end was played by the Ninth Party

Congress, which marked the close of an important stage of the revolutionary process of building the new social order and inaugurated a new and distinct, qualitatively higher stage. In view of the stage of socialist construction in Romania, the Ninth Party Congress set the goals and guidelines for consolidating socialist Romanian society and its technical-material base and for preparations to begin the all-around development of socialism.

The strategy for building the fully developed socialist society in Romania was set and enriched in the RCP Program approved by the 11th Party Congress, in the documents of the 12th Party Congress, and in Nicolae Ceausescu's theoretical works. The provisions of the Draft Directives of the 13th Party Congress place it in a new and bright light, and their implementation will ensure intensive development of the technical-material base, accomplishment of the RCP Program for Building the Fully Developed Socialist Society in its general lines, and the necessary conditions for beginning work on the higher stage of socialist society and communist construction in Romania in the next period.

The consistently dialectical and revolutionary conception of building the fully developed socialist society in Romania eliminates the simplistic and one-sided ideas of socialist construction and includes the whole series of social aspects and components in inseparable unity with economic development, bringing out their interaction and the active role of the superstructure and intellectual activity.

ION REBEDEU: In discussing the present and future continuity of the revolutionary process I think we should begin with the strategic aim of the present stage, namely a new quality of work and life which, upon in-depth analysis, reflects the distinctive features of this stage concisely but very conclusively. Achieving a new quality of work is an eminently revolutionary process. Essentially, it means not only revision of the economic structures to meet the demands of the new stage of the technical-scientific revolution and the effects of the world economic crisis as well, consistent introduction of technical progress, greatly intensified scientific research, and greater productivity and efficiency in all socioeconomic activity, but also creation of a climate of great professional competence, high standards, and perfect order and discipline, better organization of production, bold promotion of the new, and intolerance of red tape, conservatism and complacency. These are all basic aims of the 1986-1990 Five-Year Plan and are entered in the Draft Directives of the 13th Party Congress.

When we speak of continuity of the revolutionary process I think we must bear in mind the main elements that make socialism a new and better social system. Of course higher labor productivity is paramount here, but we must also allow for the dialectical connection among all components of the socialist system, including social and production relations. The fact is significant here that as it says in the Draft Directives of the 13th Party Congress, development and modernization of the productive forces, mechanization and automation of labor, and increased productivity of all socioeconomic activity in the coming years will make new changes in the way of eliminating the essential differences between the conditions of physical and intellectual work and the class distinctions, and there will be increasingly close ties among workers, peasants and intellectuals and among all social categories. This will strengthen the entire people's unity and cohesion and further level Romanian socialist society on a new basis, while the performance of the whole system of organs of Romania's revolutionary workers democracy will be even further improved.



The continuity of the revolutionary process calls for formation of the new man as a purposeful builder of socialism and communism as an essential factor in the present stage. I feel this is a pivotal element in this stage, one that stems partly from the Romanian conception of socialism and from the nature of the new order (the individual as the supreme value and purpose), and partly from the need of creating and consolidating a climate favorable to the true advancement of the individual as a personality, and from the necessity of his active involvement in all respects in the attainment of the goals of the new social order.

ION TUDOSESCU: Actually the characteristic features of the present stage can be better understood in the light of the qualitative processes going on today in the structure and evolution of society. I have in mind particularly the qualitative restructurings occasioned by the scientific-technical revolution in the area of the technical-material base of society (on the level of the structure and performance of the material production means and on that of the competence and motivation of the agent of social action). Among the effects of the innovations being made today in the area of the technical-material base I would include the structural changes in the sectors of the national economy and the changed relationships among them as well as the improvement of social relations among people and of the production and distribution relations. In regard to the latter I would stress the necessity of viewing them historically. They do not remain static when the development of the productive forces of society, the structure and quality of the technical-material base and the labor force, and the axiological and teleological motivation of the historical agent's action is disturbed by radical qualitative changes.

Among other characteristics of the present developmental stage of Romanian socialist society I would note the humanizing aspect of socialist social relations. Whereas socialist socialization of the individual was effected in the previous stages of socialist construction, in keeping with the strategies of those stages, I believe personalization of the individual by society is a major aim of economic and social construction in the present stage, and it is the mission of socialist relations to lend the best aid to this personalizing process. It is a matter of taking a dialectical view of the complex relationships between the individual and society. Furthermore, the RCP's definition of revolutionary humanism is based on such a correlation, and the principle of revolutionary humanism and the current mechanism for human fulfillment were formulated from this standpoint of the individual's fulfillment through society. On a new objective and subjective basis, it is recommended that the 13th Party Congress define the main objective of the present stage in terms of such comprehensive processes as construction of the fully developed socialist society, enhancement of the entire people's material and cultural welfare, and formation of the new man of socialist society.

Basing the principle of humanism in the present stage on the individual in his capacity as agent and personality has nothing in common with the strategy of the old renaissance or bourgeois humanism (one-sided, abstract and speculative, exaggerating the individual's interests at the expense of the social ones and thus removing the objective support of his generic existence) but indicates a higher level of its correlation with society, the unity of personalization with socialization and of social construction with human edification. The traditional and more or less recent forms of human alienation and corruption have no place in such a correlation.

ILIE VADUVA: I think the question of the stages of the revolutionary process and their characteristics is closely related to the question of the developmental stages, which are highly important in any historical period. This is because we must always determine not only the point that has been reached by socioeconomic development but also the other stages through which it is to pass in order to be able to direct its evolution. There is an inseparable unity between the nature of the national economic structure and the level of economic development and its developmental stage, an interdependence wherein the stage of socioeconomic development closely correlates both the level of development and the nature of the national economic structure.

As we know, Romania began the task of socialist construction at a low developmental level characterized by a backward industry and agriculture, so that we could say that the initial stage of the revolutionary reforms was that of an underdeveloped country, backward in its exploitation of its material and human resources. At the National Party Conference in July 1972 Nicolae Ceausescu said that thanks to the changes made in the productive forces Romania had overcome the state of economic backwardness from which it had started and the main indicators of its development placed it among the developing countries.

The analysis of the great progress made by the Romanian people in the 40 years since the August 1944 revolution, and especially in the last 20 years, that the party secretary general presented in his address to the Solemn Session of 22 August 1984 brings out both the developmental stage we have reached through the people's efforts and the directions in which the national economy is to develop so that we can pass through new historical stages in the struggle for progress and civilization.

As we know Romania is now in the stage of building the fully developed socialist society, which began with the 1971-1975 Five-Year Plan and will be concluded in its main lines by the end of the 1986-1990 Five-Year Plan, as specified by the RCP Program and the Draft Directives of the 13th Party Congress. By the end of that period Romania will have passed the stage of a developing country, consolidating its medium developed economy intensively so that in the next decade of 1991-2000 it will continue to advance firmly in the direction of creating a modern economy and a society fully developed both in its industry, agriculture etc. and in its education, science, culture and levels of prosperity and civilization.

Accordingly, in a relatively short historical period of about 50 years socialist Romania is passing through several stages, from that of an underdeveloped country to that of a developing country and then to the stage of a medium developed country, so that near the year 2000 it will become a strong and modern fully developed socialist state, thus laying the foundations for its transition to the communist principles of work and life and the higher stage of the communist system.

It took about 20 years to get over the stage of an underdeveloped country and change the structure of the national economy and about 15 years to pass the stage of a developing country and build an economy with a modern industrial-agrarian structure, and the period of consolidation, on a higher qualitative level, of all these great accomplishments and becoming one of the developed national economies will take another 15 years. These are all periods of great and truly revolutionary economic, social and political reforms that were and are characterized by

intelligence, skill and complete confidence in the RCP's ability and power to lead the Romanian people toward their most precious goals of freedom, prosperity, happiness and peace.

CONSTANTIN ENACHE: Treatment of the problem of the stages of the revolutionary process and those of Romania's socioeconomic development requires, in my opinion, consideration of both the elements in common and the existing differences. Regardless of whether it is a question of stages of socialist construction or stages of economic development, in both cases the advance to new and higher levels of socioeconomic progress goes on.

The stages of socialist construction in Romania are stages of inauguration, consolidation and development of socialism and of increasingly complete assertion of its potentials and superiority. Since the new order is being built under different specific-historical conditions in each country, it goes without saying that the socioeconomic objectives and tasks both differ in each country as well. In other words, although it is a matter of a common origin and maturity of socialism, the situation in economic development is different. Some countries have to overcome underdevelopment while others do not but go on with their development under socialism from a higher level. Consequently the stages of economic development to be traversed have not been and are not the same for all countries.

I feel that on the whole some conclusions can be drawn from examination of the stages of socioeconomic development that Romania has traversed in the last 40 years, namely that overcoming the stage of underdevelopment in Romania is taking a relatively long period (which includes the stage of consolidating socialism as well as part of the stage of building the fully developed socialist society) due to the stage from which we started to build the new order as well as the fact that the concepts of a developing country, a medium developed one and a developed one are, in my view, specific-historical concepts with a content that is constantly enriched by the contemporary scientific-technical revolution, and that, to be sure, demands increasingly great efforts; and that when the stage of constructing fully developed socialism is over the economy will reach a medium level that will then make it possible, through further strengthening, to become one of the developed socialist countries by the year 2000. Accordingly the transition to communism will require Romania to be economically developed.

NITA DOBROTA: In connection with the question being discussed here I would point out the particular importance of the party secretary general's conclusions and judgments formulated in his speech at the Solemn Session on the 40th Anniversary of the Revolutionary Act of 23 August 1944. That important document points out that the August 1944 revolution inaugurated a distinct period in Romania's development, chiefly consisting of the transition from the bourgeois-landowner society to the fully developed socialist society.

The criterion for delimiting this period is that of the socioeconomic composite, that is all the elements considered in defining the respective concept, namely the productive forces, production relations, social structures, superstructure, etc. On the basis of this criterion (which actually comprises a system of partial criteria), in-depth study of the single direction of this whole period, and the reality and requirements of the continuity of the revolutionary process throughout all the stages covered in this period, the party secretary general

said, "Romania can undertake to be, by the year 2000, a fully developed country wherein the Romanian people's lives will meet in all respects, both materially and culturally, the standards of a free people highly developed both physically and intellectually who are building communism."

I too would stress the fact that the period inaugurated by the Ninth Party Congress stands out brilliantly in the whole period of great and radical revolutionary reforms of the last 40 years as the period richest in achievements in Romania's entire history and one inseparably bound up with Nicolae Ceausescu's tireless activity performed with vision, a profoundly creative spirit, revolutionary zeal and inspired patriotism. It is with justified patriotic pride and gratitude that the Romanian people call this period "the Ceausescu Era."

This period is most fully characterized by the RCP's persevering effort to bring the quality and effectiveness of all activities up to higher levels. It is the period wherein the party secretary general, with his exceptional grasp of the nature of the realities and his brilliant vision, set the strategy for raising Romania to new heights of civilization by using the levers designed to make better use of the created technical-material base, Romania's natural resources, and the human factor, especially through intensive involvement of scientific research and the entire people's creative capacities.

ION TUDOSESCU: Of course the profoundly revolutionary significance of the social processes going on in the present stage exhibits many aspects, one of which I would like to discuss further. All the previous stages of socialist construction in Romania adhered to a certain line of progress. But the present stage of constructing the fully developed socialist society marks the end of a particular process or direction of development and opens up new prospects. This stage ends one historical period and developmental structure and begins another historical period in which the strategic objective is defined and a new structure of the developmental process is applied in practice. Hence the requirement to regard the new stage as a transition to a new quality in all social activities. To be sure the trends of this stage carry on those of the previous stages, but I think they indicate a process of radical change and a revolutionary leap of macrosystemic significance.

Methodologically I think we must regard socialism as a society of several stages and a history of its own. These stages succeed each other not only one after another but also one from another. Occasionally a "rent" appears in this genetic succession that changes its structures and makes both improvements and strategic revisions. Such qualitative changes necessitate a sound perception of their nature (Hence the importance of the cognitive procedures for the changes not only in the material and organizational system but also in the social set of values. The changes taking place in the set of values must be carefully watched) as well as a strategic basis, and those require extensive long-range measures which, in correlation with the technological replacements occasioned by the new value judgments, call for new programs and plans for economic, social and human activities. The Draft Directives of the 13th Party Congress include such a discursive-theoretical operational planning operation, redoubled by the corresponding strategies.

PAMFIL NICHITELEA: Nicolae Ceausescu's works closely correlate the idea of continuity of the revolutionary process with the necessity of promoting the

revolutionary spirit and the objective requirement that the workers and all citizens of Romania act according to the nature and demands of the present stage. While the revolutionary process is a composite one running through various stages in one unity and every stage has its own objectives, naturally the revolutionary spirit also takes on different aspects from one stage to another in a continuous process against the background of basic socialist values. As the party secretary general pointed out in his speech at the Mangalia Working Conference, "We are now in a higher stage of socialist construction wherein we have problems to solve that are critical to the future of socialist Romania. Therefore the work of the party and its members must also rise to a new level and be imbued with a militant revolutionary spirit."

In this connection, the Draft Directives of the 13th Party Congress opens up new and bright prospects for the all-around progress of Romanian socialist society and for the whole people's greater material and cultural welfare. Accomplishment of these great aims will raise the revolutionary process in Romania to a higher level, making it even more necessary to keep fostering the militant revolutionary spirit among the masses.

GHEORGHE SURPAT: The growing complexity of the revolutionary process of building the new social order makes it an objective requirement to keep developing the RCP's role as a political force leading and stimulating all social and economic activity and to keep promoting the revolutionary spirit more intensively in all activities of the communists and the workers. In the present stage the RCP, in close alliance with the working class, the intelligentsia, the peasantry and the entire people, is making an extensive theoretical and practical effort to provide a scientific socioeconomic leadership, to form the masses' socialist awareness, to keep enlarging their ideological, political and general cultural horizon, and to boldly promote the new and the militant revolutionary spirit in step with the new objectives and tasks facing the Romanian people as they are forecasted in the Draft Directives of the 13th Party Congress.

In its policy and its activity the RCP is consistently promoting what Marx called the "critical revolutionary spirit" by encouraging and developing the new and progressive in all social activities. The creative, profoundly scientific and humanistic revolutionary spirit is vividly reflected in the continuing effort of the party and its secretary general to fully exploit people's creative powers and to further enhance their progressive revolutionary awareness and their level of knowledge and mastery of science, technology and the latest advances in those fields so that all their energies will be devoted to the cause of the people, the party and socialism. In the RCP's view, a revolutionary patriot is a bold explorer of the new trail blazed by socialism and communism, intolerant of shortcomings, a determined foe of all that is outmoded, and a courageous promoter of all that is advanced and progressive. He is a competent man with good training, a good organizer, and a man of high moral standards purposefully leading the masses by organizing and guiding their work and efforts on behalf of socialism, communism, and consolidation of national independence.

The revolutionary spirit is fostered by particular combinations of personal responsibility with work in the collective, by encouraging initiative, criticism and self-criticism, and by improving the workers' knowledge and occupational, political and ideological training. Today the revolutionary spirit appears in

practice and actions through every worker's efforts to maintain a new and higher quality in all activities and establish a climate of great responsibility and firm, exacting standards in order to carry out the RCP Program consistently and bring Romania up to new heights of progress and civilization. Actually all the great progress made by the Romanian people in the 40 years since the Revolution for National and Social Liberation and all that we shall accomplish in the future are due to the workers, their determined efforts under party leadership, and their revolutionary spirit.

CONSTANTIN STROE: Although the revolutionary spirit is focused upon political values, I think it necessarily requires moral qualities as well, such as dedication, firmness, responsibility, humanism etc. Moreover that spirit can be promoted only by maintaining the values and principles of socialist ethics and justice in the work and lives of all Romanian citizens. They alone can provide the strength and power needed to overcome any difficulties in implementing the objectives and tasks assigned by the party in the present period.

The revolutionary spirit has also figured in the previous stages, to be sure, but with a different content. Specifically related to the content of Romanian society's present developmental stage, the revolutionary spirit is acquiring particular determinations because, from a manifestation of states of revolt and struggle against exploitation in an older period, the revolutionary spirit has now become the main expression of the masses' loyalty to the socialist system and their determination to secure the nation's prosperity and all-around progress. In this new sense the revolutionary spirit also embraces a profoundly humanistic attitude and an understanding on everyone's part of the general interests and the Romanian people's bright goal of communist construction. From this viewpoint I think the revolutionary spirit takes the higher form of an understood necessity, because the revolutionary spirit is actually the basic quality that characterizes and defines communists as people who understand their role and mission in society better than others and who are firmly resolved to serve the nation and the people with energy and dedication. Accordingly the revolutionary spirit calls for a high civic sense and progressive social conduct, and in that respect it constitutes a main characteristic of the new type of man and a synthesis of political, ethical and professional qualities. It both stimulates and lends substance to his entire life and work.

Therefore in order to promote the revolutionary spirit all members of society must be indoctrinated with communist convictions and attitudes at work, in the family, and in society. To this end the RCP documents call attention to the inseparable bond between development of the revolutionary spirit and promotion of the principles of socialist ethics and justice. Nicolae Ceausescu said, "We must make a determined effort to enforce those principles in all fields by combatting and taking a firm stand against any tendencies to disregard or violate them."

ION REBEDEU: When we speak of promoting the revolutionary spirit in the present stage, of course we are implying that it has a number of distinctive features, and I think one of them is the qualitative aspect, that is the special emphasis placed upon achievement of a new quality of work and life. No doubt quality has been an objective before, but in this stage it means qualitative exploitation of all that has been accomplished in accumulation, in the technical-material base

of socialism, in social and production relations, and in many other social activities as well so that socialism will manifest its superiority in all aspects and in all sectors of Romanian society.

Accordingly it is a matter of a veritable offensive of qualitative innovations in a comprehensive view of socialism and the values that characterize it and bring out its superiority as a social system. Today we speak quite rightly of a new agrarian revolution, a revolution in the human personality (meaning formation of the new man according to and on the basis of the set of values of revolutionary socialist humanism), and of the beginning of a new stage of the technical-scientific revolution with profound qualitative effects upon economic development and society in general, etc. These "sequential" revolutions, which are being accomplished on the basis of socialism and are in fact intended for its all-around fulfillment and the gradual advance toward communism, require intensive promotion of the revolutionary communist spirit as an objective necessity.

Comprehensiveness is a characteristic of the continuity of the revolutionary process in the present stage. This is graphically illustrated by the very idea that is basic to the Draft Directives of the 13th Party Congress, which anticipate new and radical revolutionary changes in all sectors of Romanian society, and each and every sector will undergo many innovations. In the economic sector, for example, changes are being made in the economic structures as well as substantive innovations in the introduction of technical progress, professional competence, qualifications, management etc. It is accordingly a matter of a multitude of elements, objectives, standards, courses of action etc., that indicate the extent and depth of the changes the party considers necessary to build the fully developed socialist society, a comprehensive task that is impossible without the masses' revolutionary contribution and without revolutionary dedication and responsibility.

#### The Revolutionary Spirit in Action

VIOREL CORNESCU: Actually the comprehensiveness that characterizes the revolutionary process in Romania in the present stage stems from the very conception of construction of the socialist order as a profoundly democratic order that is being developed rapidly and evenly in all its components. To this end, the RCP has clearly perceived and integrated in its strategy for social development the entirety of the links forming between the economy as a part and society as the whole, and it is mobilizing all the factors that contribute to economic growth, such as advanced socialist awareness; active participation of all workers as owners, producers and beneficiaries; and creative thought capable of devising new and original measures, suitable forms of organization and management, etc.

I believe application of creative power on all levels of activity is one of the most important factors for promoting the revolutionary spirit today. I regard creative power and originality as major components of socialist construction, deeply involved in development and improvement of all aspects of socioeconomic activity. Promotion of innovations, in conformity with the objective social laws of course, provides for the progress and balanced and harmonious development of the economy and accentuates the qualitative factors in all fields. That is why we cannot speak of socioeconomic improvement without including creative power and original revolutionary thought applied to both theory and economic practice,

which give rise to new ideas and innovations in organization and management of all socioeconomic activity, et al.

CONSTANTIN ENACHE: The revolutionary spirit is certainly no abstract idea but a practical matter with a particularly rich content and direct effects upon people's activities and national socioeconomic development. As Nicolae Ceausescu pointed out in his recent speech in Slatina, implementation of the decisions to be made by the 13th Party Congress and of the RCP Program "requires good organization of labor, improvement of all activity, and complete unity of action in a revolutionary communist spirit on the part of all socioeconomic units and all workers under the lead of the party organizations."

In the economic field, I think the revolutionary spirit means the formation of a better mode of thought and action at work and in management and use of human, material and financial resources, as well as the unremitting struggle against the outmoded and on behalf of the new, advanced and efficient and economic and social progress. It calls for progressive behavior in social production as well as enthusiasm, initiative and a high sense of responsibility.

Intensive economic growth in the present and in the period of 1986-1990 and on to the year 2000 as well, as provided in the Draft Directives of the 13th Party Congress, requires full manifestation of the revolutionary spirit on the part of all workers and in all organizational structures of the economy. Of course the revolutionary spirit can not be manifested automatically but requires sound professional and political training, advanced awareness, mastery of scientific disciplines, formation of the necessary habits, etc. The shift to a higher quality throughout the economy naturally requires a new quality in people as well, so that they will act quite knowledgeably in building their own future.

ILIE VADUVA: The revolutionary spirit in the economy is also promoted because application of the latest and most effective advances of science and technology is basic to intensive development of the productive forces and will be even more so in the future. It is also borne out by the results obtained compared with the effort made and with the best existing results on the world level. By these standards, I think to be a revolutionary in the economy means to militate competently and responsibly for highly efficient implementation of all assigned aims and tasks by all economic units. Among other things, this requires a sharp rise in labor productivity and considerable reduction of material outlays in close correlation with technical and qualitative improvement of products and with more intensive and better use of raw materials, fuel and energy. In economic management, I think the revolutionary spirit is largely manifested by the effort to enhance the efficiency of workers self-management and to secure all workers' increasingly wide competent and responsible participation in management as owners, producers and direct beneficiaries of all national wealth.

VIORREL CORNESCU: When we speak of the new economic-financial mechanism and the need of its further improvement I think we should always bear in mind the role of the subjective factor which, on the basis of the realities and demands of socioeconomic progress, not only produces new and original ideas but also provides for their application to the economy. Accordingly I believe we are seeing two stages going on in the process of improving the economic mechanism, namely development of new and original ideas, or innovation as a reflection of creative



power, and application of the innovation, or creation in the form of implementation of the new. I think it is only by opening wide the gates of the new and encouraging the creative thought of the specialist and all workers that we can speak of promoting the revolutionary spirit in the economic field. On this basis social innovations and acceleration of general socioeconomic progress are entirely possible. I regard the innovation process as an inexhaustible source of development and a basic factor for socioeconomic growth. It is to the credit of the RCP and its secretary general that they created and developed the conditions necessary to promote creativeness and originality in the economic sector and in other sectors as well. The recent Decision of the Political Executive Committee of the RCP Central Committee on new measures for improved application of the economic-financial mechanism, lower interest rates, maximum profitability of a number of products, encouragement of workers and enterprises to increase labor productivity, introduction of technical progress, better product quality, reduced costs and more pronounced growth of economic effectiveness is particularly important in this respect.

ION TUDOESCU: The statements in the party documents of the last few years concerning the Romanian worker's capacity or capacities as owner, producer and beneficiary in the present stage are of great methodological importance to treatment of the axiological aspects of Romanian society, and I think the capacity as organizer of social activity and production could be added to them. All these capacities flow from the nature of Romanian social relations, the nature of ownership of the production means on which those relations are based, and the nature of the organizational structures that enhance and protect them. But inasmuch as the socialist production relations and the organizational structures based on those relations are historical, it is logical to conclude that the worker's capacities are historically instituted and historically valid. I believe the question that arises here is that of the ways of instituting the worker's many capacities in socialist practice and the ways of fully perceiving their qualities, for it is only on the basis of that perception that the feelings as owners, producers, beneficiaries and organizers can be established in the workers' minds on the level of their axiological horizons.

OLIVIA CLATICI: Continuity of the revolutionary process also applies, of course, to the political sector. The political factor, with an important regulating function in society, faithfully reflects the revolutionary changes in the base of society, and it also overtakes the course of actual life to some extent. That is natural because the politician, by his decisions, is constantly setting new and challenging goals to enhance the revolutionary process. As we know, the Romanian political system has passed through successive stages of improvement and fulfillment along with the general process of revolutionary reform.

This dialectic of Romania's political evolution has been repeatedly noted by Nicolae Ceausescu, who stressed the point that an original system of socialist democracy, unique of its kind, was created in Romania, and the efficient operation and full use of that system are the essential problems now. Of course we can speak of a scientific revolutionary management as a constant of Romanian socialism in a revolutionary workers' democratic state with increasingly efficient exercise of the party's political leadership.

ANGELA BANCIU: The new, original and profoundly revolutionary system instituted in Romanian politics was made possible and necessary by the accumulation in time

of quantitative and qualitative results in the course of building socialist democracy. It represents a new quality of Romanian democracy and is a powerful impetus to economic, political and intellectual activity in all sectors of society, contributing to adoption of democratic practices by all categories of workers.

The very far-reaching tasks of building the fully developed socialist society and of the advance toward communism, the demands of the new stage of the contemporary scientific-technical revolution, and the necessity of drafting national programs to improve labor productivity and product quality and of converting the quantitative accumulations to a new and better quality of production, work and social activity, all those are made possible by development of the democratic forms of organization and activity of socialist society. Essentially socialist democracy is emerging as a vital factor for the progress of the individual and society, and its constant enhancement is the basis for continuous strengthening of Romanian society and a major requirement for continuation of the revolutionary process on new and higher levels. Accordingly the Draft Directives of the 13th Party Congress point out that in the coming years "The operation of the whole system of organs of Romanian revolutionary workers democracy will be raised to an even higher level, as well as the united participation of all categories of workers (as producers, owners and direct beneficiaries of all that is produced in Romania) in social and economic management and in purposeful construction of Romania's new socialist and communist future."

OLIVIA CLATICI: The new organizational structure of the revolutionary workers democracy, subject to future improvements to be sure, offers every worker the opportunity to participate in social activity on many levels. Of course fulfillment of this opportunity depends upon creation of a climate everywhere that will favor participation and lend it a real content on all levels and for every individual's existence, and also upon the increasingly pronounced assertion of every citizen's sense of responsibility and socialist awareness. Unfortunately we still find instances of bureaucracy and disregard of the established democratic framework and climate in some economic units and workers collectives. Determined elimination of such defects and a regular effort to secure all workers' active participation in socioeconomic management are important constants of promotion of the revolutionary spirit in the present stage.

I also think we should examine the revolutionary concept of participation in greater depth. The technical literature sometimes uses the term in too narrow a sense. It is unduly simplified, and its content is limited to participation in management, whereas the concept has a broader and more comprehensive meaning of participation in joint ownership of socialist property and its development; active participation in work and the social division of labor; intensive participation in social relations and improvement of distribution relations; participation in the democratic structures for social organization and management; participation in intellectual and cultural activity; and participation in the whole effort toward socialist Romania's advancement in the world. I feel those are all objectives of the militant revolutionary spirit in the present stage.

PAMFIL NICHITELEA: The development and exercise of the party's leadership in all activities are essential to promotion of the revolutionary spirit in the social and political activity of Romanian society. That leadership does not exclude or

restrict democracy in any way but, on the contrary, it is essential to its amplification and improvement. The RCP performs its political role through its extensive and continuous dialogue with the people and its complete integration in society. The party organs and organizations themselves form a favorable framework for free and responsible discussions and promotion of the creative, revolutionary spirit. Therefore generalization of the party's characteristics and the clear example set by Nicolae Ceausescu's entire activity and approach throughout all society is critical to democratic progress in general and might be called the measure and the guarantee of further amplification of Romania's revolutionary workers democracy.

ANGELA BANCIU: As the vital center of socialist Romania, the party is proving in practice the social value of its broad functions by, among other things, its consistent and wise use of a particular system of methods of coordinating all social activity and checking the suitability and efficiency of management actions, a system that uniformly combines several essential features. Thus the RCP bases its entire social managing upon criteria for social action with a true democratic significance (all-around social progress, material and cultural development of all areas and counties of Romania, all-around development of the human personality, etc.), criteria incorporating important democratic standards of value such as social equity and justice, equality, liberty, responsibility and human dignity. These standards are acquiring the status of benchmarks in the conduct of social programs through their inclusion as major reference points in the party's scientific social management.

Meanwhile the party is evidencing many possibilities of directing implementation of the plans for social action in practice by its work in shaping the awareness of the party members and of the masses of workers in general, by indoctrinating them in the militant revolutionary spirit, and by its constant receptiveness to the new and to the facts of social practice. Its inseparable tie with society and the people whose interests it serves, with all mass and public organizations and with all socialist state institutions are an intimate part of the democratic mechanism of political management of Romanian society. Nicolae Ceausescu said, "The party does not lead in the name of but together with the working class, all workers regardless of nationality, and the entire people."

MARIN BADEA: New and original elements stemming from Nicolae Ceausescu's theoretical thought have truly enriched our revolutionary view of the evolution of the party and its leadership in Romanian society, which is of course inseparably bound up with the processes of developing democracy and the role of the socialist state and making its functions more effective. The growing complexity of the tasks of national socioeconomic development while circumstances increasingly demand greater responsibility and capacity for initiative of every communist and every worker makes it necessary to increasingly improve the political, ideological and educational work of the party and all its organs and organizations in order to carry out the RCP Program and the decisions approved or about to be improved by the 13th Party Congress.

CONSTANTIN STROE: It is to the RCP's credit that it has spurred work in that direction through a creative and realistic approach to the relationship between social existence and social awareness. In the new order the dialectics of that relationship are not confined to the point of reflection of the facts of existence

in the social awareness but assume the active, reforming and far-seeing role of socialist awareness and its implementation in practice. This emphasis is especially necessary because the the problem has sometimes been oversimplified and vulgarized, with one-sided and stereotyped interpretations exaggerating some one aspect of social activity, usually the material one, and consequently overlooking the necessity of harmonizing them.

In eliminating the irrational attitude of expectation the RCP has made no fetish of the theory of the lag in awareness but has worked with both the material and cultural conditions alike in order to form the new socialist awareness, which is to become a powerful motive force for Romanian society's progress. As Nicolae Ceausescu pointed out to this effect in his address to the Expanded Plenum of the RCP Central Committee in June 1982, "We must always bear in mind that the mode of thought, social awareness, and the developmental level of science, education and culture are determined by the material base of society and the methods of producing and distributing the material goods. Meanwhile social awareness, science, education, culture and ideological and political-educational work play an important part in development of the productive forces. Both aspects of activity interacting in a dialectical unity secure further social progress, improve the people's welfare, and strengthen national sovereignty and independence."

Increasingly intensive development of the revolutionary reforming role of socialist awareness in socialist Romanian society is an objective necessity. I would note some of the many reasons for this role, such as the new kind of social determinism peculiar to socialism, whereby the role of the people as creators of history is even further advanced and the importance of the subjective factor in the purposeful and planned organization and conduct of the social processes is increased; the greater volume and complexity of the tasks of construction, which demand better training and competence, a high political, ethical and civic standard, and a high sense of responsibility; the particular role of the political factor, reflected both in the masses' socialist political awareness and in political relationships and the party's organization and management of society; the growing importance of science in management, organization and consolidation of society; and the ever greater role of socialist ideals and principles in regulating and improving social relations and in rallying the masses to the effort to carry out the party policy.

**ION REBEDEU:** Creative revolutionary solution of the problem of correlating social existence with social awareness involves both aspects of the established realities in Romania and improvement of both social existence and social awareness as a basic requirement for the balanced development and accelerated progress of Romanian socialist society and for conversion of revolutionary awareness to a powerful factor for progress. Socialist awareness in all its aspects is becoming particularly important in this stage, when there is a socialist economic base, new production relations, extensive democratic administrative structures, a wide institutionalized framework for the masses' participation in all economic and social-political activity, and a strong and modern technical-material base.

**CONSTANTIN STROE:** Seeking to enhance the reforming role of social awareness as a motive force for social progress, the RCP is trying to cultivate its revolutionary spirit consistently and to keep it unaltered. Socialist awareness, especially in its nucleus of revolutionary ideology, stimulates creative activity in

all areas of social practice. Its influence stimulates and makes social use of all that is constructive and uplifting in man and his entire reserve of thought, feeling and creativeness in order to raise him ever higher on the scale of progress, creation and his fulfillment.

The RCP's efforts to develop revolutionary socialist awareness play one of the most important parts in molding the human personality and its advanced thoughts to meet the present and future requirements of socialist society's progress. Since the new aspects and values of socialist awareness increase in importance with progress in building the fully developed socialist society, the RCP and its secretary general include development of socialist awareness among the main ways to attain the major objective of the present stage, namely the shift to a new quality in all fields. A new quality of socialist awareness is being achieved by a great many levers and the efforts of organizations and institutions, mainly the RCP as the leading political force of Romanian society, and intensive development of its revolutionary reforming character is an essential feature of the process of achieving it.

NITA DROBOTA: Upon examining the RCP's and Nicolae Ceausescu's conception of the specific-historical content of the revolutionary spirit I believe that, as far as economic thought and awareness are concerned, some specific requirements could be formulated for the expression of that spirit on at least the following levels: economic theory (or political economics), the system of economic sciences and the economic thinking of all workers and especially those directly engaged in managing the national wealth.

As we know the Draft Directives of the 13th Party Congress formulate a number of requirements and tasks for economic research, pointing out that it is only by accomplishing these highly responsible tasks that the aims of national socioeconomic development in the next few years can be accomplished. For instance, developing ways to increase effectiveness more rapidly, to modernize the material production structures further, to increase labor productivity, to lower production costs, etc. is a major task of economic research in this stage. The solution of all these problems requires consistent promotion of the new in the economy and a revolutionary attitude.

A revolutionary spirit must also appear in all workers' economic thinking. This means first of all that all those in an economic activity and especially those who directly manage the economic processes must know, understand and correctly apply the scientific principles and conclusions of political economics and the revolutionary economic theory. As Nicolae Ceausescu pointed out, "In all stages of education, we must bring up youth in the spirit of patriotism but also in the spirit of economic efficiency. The youths, pupils and students in schools and in higher education must learn and know well not only technology but also the economic problems, both those of economic efficiency and those of material consumption, and everything that has to do with more intensive growth of the national wealth. We must fully realize that the worker, engineer, technician and all our personnel in any sector, the researcher, scholar, physician or professor must also think in an economic spirit, in the spirit of responsibility for the national wealth and for socialist Romania's general development."

**ILIE VADUVA:** The revolutionary spirit in economic thought can be formed only on the basis of a high socialist awareness based on realization of the fact that while work is what created man, today it is also what the purposeful creator of the most enterprising ideals can do. Of course in the present stage it is a matter of complex work that must be based upon mastery of the latest advances of humanity but also upon a veritable cult of quality, for purposes of the progress and prosperity of the respective people as well as those of every member of society. Therein lies, I might say, one of the strongest motive forces generated by the Romanian socialist order, a force to be found in no other system, namely the revolutionary spirit formed and developed in the school of work for the nation's continued progress and prosperity.

**MARIN BADEA:** The effort toward comprehensive analysis of the major problems of socialist construction in Romania, clearly in their dialectical correlation with the vital problems of the contemporary period, is essential to the theoretical thought of the RCP and its secretary general, because the particular cannot be divorced from the general and the national and international are closely interdependent.

It has already been pointed out in our discussion that the present period is characterized by radical social and national changes, by a new stage of the scientific-technical revolution, and by a multitude of phenomena characteristic of the extensive historical process of transition to socialism, by different and increasingly varied routes, and it is affecting the content and evolution of what we are constructing. And such a historical context and such a reality, highly complex because of the multiplicity of its elements and initiatives of thought and action, can be effectively approached only from the standpoint of original, bold and dialectical scientific thought, opposed to any tendencies toward isolation and intolerant of backward ideologies, and from the standpoint of thought suited at any time to innovating expression in accordance with the requirements of revolutionary humanism. Hence the militant spirit of the RCP's political philosophy and its capacity to approach reality creatively, a standard, by the way, frequently mentioned by the party secretary general. As he points out, "A communist revolutionary is a bold explorer of the new, always looking ahead to what is developing, thinking boldly on the basis of the masses' revolutionary experience, and working to unite their efforts toward revolutionary social reform."

With Nicolae Ceausescu's encouragement and telling contribution, the RCP has made an extensive effort in the years since the Ninth Party Congress to study in depth the complex problems of the new developmental stage of socialist construction in Romania as well as the essential processes and highly contradictory trends appearing in the world today. The theoretical ideas and original views it developed have enriched the RCP's ideological treasury, broadened the political and theoretical horizons of the communists and workers, and enhanced the RCP's contribution to the promotion of the Marxist conception and the ideology of scientific socialism.

**PAMFIL NICHITELEA:** The RCP's theoretical, ideological and political-educational work is consistently based upon the Marxist conception and the principles of scientific socialism and revolutionary humanism. Thanks to Nicolae Ceausescu's suggestion and telling contribution, we have a unified ideological program already verified by social practice that assigns clear directions and specific tasks for work in education, science, literary-artistic creation, the press, radio and TV,

and practically all the fields and elements expected to help improve political-ideological work and socialist indoctrination of the masses. In his spirit, it is the mission of educational work to contribute to mastery and application of the party policy, to development of ways of further improving socioeconomic activity, and to improvement of the ideological and political standards of the communists and all workers, and to promote the Marxist conception, advanced ideas, and their reforming, revolutionary and militant power.

From this standpoint, the requirement to develop revolutionary thought and to arm people with the ideas and principles substantiated by the party and its secretary general is gaining in importance in educational work. The RCP understands this activity to mean developing the ability of the communists and all workers to regard and judge the surrounding realities in the spirit of dialectical and historical materialism. Marxist ideas and materialist dialectics are valuable not as sources of knowledge ready-made once and for all but primarily as tools for investigating reality, for developing new disciplines and an active, militant presence in the ideological confrontations of our time, and for critical assimilation of culture.

It is particularly necessary to lend a militant revolutionary spirit to all political-ideological and educational work because, as the party secretary general pointed out in his speech at the Mangalia Working Conference, "Compared with the great progress in socialist Romania's development, there is a certain lag in revolutionary socialist awareness." As the party documents and Nicolae Ceausescu's speeches indicate, from the practical point of view this calls for full use of all of society's levers, the state, the public and mass organizations, the cultural-educational institutions, and the system of socialist legal and ethical standards to bring political-educational work up to a higher qualitative level.

PETRU PANZARU: The true revolutionary spirit is inseparable from revolutionary action in everyday practice. It is imbued with and dominated by the seriousness and sobriety of work and creativeness and the persevering effort to detect and overcome contradictions, to prevent difficulties, errors and defects, and to foster a high sense of political and professional responsibility. Because action and creative, constructive activity are the essence of the revolutionary spirit, it necessarily demands competence, continuous improvement of professional, economic, technical and scientific training and, not last, a high political and ideological level. I would call the revolutionary spirit the antidote for technicism. I regard the harmonious combination of professional competence and the capacity as a specialist with political competence or the capacity as a politician as the quintessence of the constructive revolutionary spirit characteristic of the present stage of Romania's development.

Accordingly, to be a revolutionary today means to be a builder of new, modern, functional and highly efficient socioeconomic capacities, a creator of material and cultural values on a high qualitative level, a promoter of high social and labor productivity, an active participant in social management, a staunch fighter for protection and development of socialist property, and a builder of new human relations characterized by the spirit of socialist ethics and justice. The revolutionary spirit also calls for a firm militant attitude toward bourgeois and petty bourgeois ideas and turns of mind, toward backward attitudes at work, in life and in society, toward mystical, nationalist, chauvinist and cosmopolitan ideas, and toward the perfidious attempts of anticommunist propaganda to

pollute the awareness of the members of Romanian society, and to inject the poison of distrust and scepticism.

It may be said that in the present stage the revolutionary "battle" is being continued on all fronts of socialist construction, spurring and driving both the material and cultural activity of Romania. The eminently constructive and creative nature and the consistent, complete and simultaneous accomplishment of all the objectives of the fully developed socialist society, improved social organization and management, and better performances in socioeconomic activity and in political-educational work are the distinctive characteristics of the revolutionary process in Romania in the present stage.

5186

CSO: 2700/91



27 March 1985

ROMANIA

## SPEECH AT PRAGUE CONFERENCE ON INTERNATIONAL COMMUNIST REVIEW

Bucharest ERA SOCIALISTA in Romanian No 3, 10 Feb 85 pp 11-13

[Speech delivered by Ion Stoian, alternate member of the Political Executive Committee and secretary of the RCP Central Committee, at the December 1984 Prague meeting on the activities of the international magazine of communist and workers parties "Problems of Peace and Socialism." Abridged text: "In the Interests of Strengthening Solidarity and Cooperation in the Struggle for Peace and Social Progress."]

[Text] The RCP delegation is attending this meeting---devoted to examining the activities carried out in the past 3 years by the magazine "Problems of Peace and Socialism"---with the hope and conviction that holding the proceedings in a constructive spirit will contribute to improving the work of this international publication of our parties.

As pointed out in the report of the editorial collegium and council, since our previous meeting the magazine has expanded its scope and has presented the experience gathered by communist and workers parties and by other revolutionary forces in the struggle to defend the rights of the working people, to achieve progressive and democratic changes in society, and to build the new social system.

At the same time, the magazine has carried theoretical material and discussions on social-political developments and on new processes and phenomena occurring in contemporary society or in certain parts of the world.

More space has been devoted to major international problems such as the struggle to prevent a nuclear war, against the arms race, and for peace, disarmament, and social progress, for eliminating underdevelopment and establishing a new world economic order, as well as to the publication of notes and material reporting on the activities of various parties, on congresses, anniversaries, and other important events. Naturally, it is important to further expand the thematic scope and the range of issues discussed in the magazine, and to avoid unilateral treatment of complex contemporary problems.

As is known, and as we agreed in our agenda, the purpose of our meeting is to examine the activities of the magazine "Problems of Peace and Socialism" in the past 3 years. Such an analysis is, of course, designed to improve the magazine. At the same time, the meeting affords us an opportunity to exchange information and experience among the parties represented here.

Our meeting is taking place amid special international conditions, at a time when tension is higher than ever and when the danger of a world war is very acute, a war which would turn into a nuclear war and destroy life on our

planet. In these conditions, it is urgently necessary that the communist parties unite their efforts and place the emphasis on what they share, namely on the joint struggle against war and for disarmament, primarily nuclear disarmament.

We believe that strengthening the solidarity and cooperation of the communist and workers parties is in the interests of our major cause--safeguarding peace and eliminating and destroying nuclear weapons. The first and most important step is to overcome all the disputes and harmful polemics that affect the cooperation between parties. In point of fact, polemics and disputes within the communist movement have only impaired unity and sapped the force of our movement. Further public polemics, disputes, and accusations of some parties by others can only serve the forces interested in escalating tension and continuing the arms race, and in the policy of force, dictate, and oppression. History can testify to the fact that such disputes and accusations have harmed the unity of our revolutionary movement.

Naturally, if there are differences of views and differing opinions on certain issues, even major ones, they can be discussed among the parties and their leaderships in a comradely spirit and on the basis of equality and mutual esteem; a common ground can be found, as can means of resolving the differences. Under no circumstance is the present meeting to be used for discussing differences of opinion, or to be turned into a forum for public polemics. It is in the interests of the cause of strengthening the solidarity of the communist and workers parties to discard any polemics and harmful disputes that can affect interparty cooperation, and to consistently promote free exchanges of views and opinions, conducted in a comradely spirit of equality and mutual respect. This will contribute to achieving a better understanding of the concerns and positions of each party and to emphasizing what is commonly shared and incomparably more important in the struggle for the general cause of peace, disarmament, cooperation, and social progress.

We have always kept in mind the role assigned to the magazine from its very inception, namely to be the forum for free exchanges of information and views and for a broad exchange of experience, so that each party can present its current and long-term achievements and interests, its theoretical and practical activities in the struggle for revolutionary changes in society and for building a world of social and national justice, and its own, original contribution to the heritage of revolutionary theory and practice. Materials along this line have, of course, been published in the period under analysis; however, as is mentioned in the report, there is still much room for improvement from the viewpoint of the magazine featuring the wealth and enormous diversity of the experience amassed by the revolutionary forces, and specific and original forms of attaining strategic and tactical objectives in keeping with the specific conditions prevailing in and the stage of social development attained by a given country.

Naturally, certain materials will in themselves carry different viewpoints concerning the building of socialism, the accomplishment of the revolution, and the role of the communist parties in the struggle for peace and for revolutionary changes; in some cases, materials will reflect an individual way of interpreting a given thesis of the Marxist-Leninist theory, in keeping with changes in the social development and with the specific conditions amid which

the parties carry on their activities. We believe that it is very useful to publish such materials just as presented by the respective parties.

As far as we are concerned, we have endeavored to present in the magazine the experience and interests of our party; we have always actively participated in exchanges of views and experience, and in various theoretical discussions organized by the magazine.

Our people, closely united around the RCP and its secretary general, Comrade Nicolae Ceausescu, are focusing their efforts on unflaggingly fulfilling the strategic objectives of socioeconomic development of their homeland and the party program for building the comprehensively developed socialist society and Romania's advance toward communism. The two great political events of 1984--the 40th anniversary of the antifascist and anti-imperialist revolution for social and national liberation of 23 August 1944 and the 13th RCP Congress--have been opportunities to review and to examine in depth the road traveled by the Romanian people during the period of socialist revolution and construction.

Within a relatively short period of time, Romania has traveled several historical stages--from a bourgeois-land owners society to a comprehensively developed socialist society--and has turned, from an agrarian country with a poorly developed industry and agriculture, into an industrial-agrarian country with a powerful and modern industry and a socialist agriculture in full process of development. Currently, our country's industrial production is 100 times larger than in 1945, while agricultural production is almost seven times larger. As a result of the rapid development of the entire national economy, the social product has increased 28 times over, and the national income 32 times. On this basis, the living standard of all our people was continuously raised.

Education, science, and culture have intensively developed and are playing an increasingly important role in the entire process of revolutionary changing of the society. The people's level of material and cultural civilization has continuously increased.

Despite some special difficulties, caused in particular by the impact of the world economic crisis, in the current 5-year plan, too, we obtained considerable achievements in all the branches of the national economy.

Marking the transition to a new stage in the implementation of the party program of building the comprehensively developed socialist society and Romania's advance toward communism, the 13th RCP Congress established the tasks and objectives for the 1986-90 5-year plan, in which special attention will be paid to developing the production forces and improving production and social relations upon a new basis, and in which the process of revolutionary changing of the society will be resolutely continued. Emphasis will be put on intensively developing all the branches of the national economy and modernizing the structure of the industrial production. In the agricultural sector, the chief objective is to implement the new agrarian revolution, which requires general changes in the peasantry's work, life, and thinking, and the achievement of agricultural productions that can fully meet consumer needs and other development requirement of the national economy. A particularly important role for

the achievement of Romania's socioeconomic objectives in the coming 5-year plan will be played by scientific research and the rapid utilization of the new achievements of science and technology in production. Thus, the revolutionary process of shaping, developing, and modernizing the scientific-technical basis of the comprehensively developed socialist society and for the transition to a communist society will continue in the last decade of the 20th century.

Our great achievements to date provide a sound basis for attaining these bold objectives; they clearly prove the correctness of the RCP policy, which is resolutely guided by the revolutionary materialist-dialectical and historical concept, and which creatively applies the generally valid truths of Marxism-Leninism to the specific conditions prevailing in Romania.

Simultaneously with extensively featuring the experience and interests of the communist and workers parties in their revolutionary struggle for social progress, for profound social changes, and for building the new system, the magazine "Problems of Peace and Socialism" is expected to provide a propitious framework for extensive exchanges of views and ideas on the international revolutionary process, and to promote a dialogue and a better understanding of the theoretical and practical contributions made by each party and by progressive thinking. Thus, it is very important that the magazine present the great revolutionary shifts and changes occurring in the particularly complex and contradictory evolution of international life.

An analysis of international developments in the past years shows that the process of consolidating revolutionary achievements and progressive changes in the world, and of strengthening the national independence of nations that have shaken off the yoke of colonialist and imperialist domination has continued during this period. At the same time, the reactionary and imperialist forces, who cannot yet accept the changes that have occurred in international life and the general trend of mankind's development along the path of progress and independence, have also taken various actions. Old contradictions have sharpened, while those between rich and poor countries have escalated to an unprecedented pitch. The world economic crisis has exacerbated the general political, social, and moral crisis of the capitalist world, and has thus more forcefully highlighted the limitations of the bourgeois system and of the societies divided into oppressed and oppressing classes. At the same time, the events of the past years have undeniably shown that the policy of detente, disarmament, peace, and international cooperation can only be pursued and consolidated through the permanent struggle of the revolutionary, progressive, and anti-imperialist forces, and of peoples everywhere.

In close connection with that, one of the particularly important problems is to ease international tension, prevent war, halt the arms race, and begin disarmament. As is generally recognized, the international situation is now more serious than ever before. It can be stated that the world has not known such tension and such a danger of war since the end of World War II, and this time war would inevitably lead to nuclear catastrophe. The policy of maintaining the division of the world into zones of influence has continued, and the arms race, especially the nuclear arms race, has intensified; the old military conflicts are still unresolved, and new ones have emerged in recent years. This is why we believe that the fundamental problem of the modern age is to halt the general, and primarily the nuclear, arms race, to begin disarmament, to

ensure a lasting peace in the world, and to safeguard the right of people and of nations to life and to a free and independent development.

The situation in Europe is very serious. In view of the present circumstances, our party believes that everything possible should be done to halt the deployment of intermediate-range U.S. missiles in west-European countries and to implement the measures taken by the Soviet Union and by certain European socialist countries on removing intermediate-range missiles, and eventually all nuclear weapons from Europe. We also believe that any attempt to use outer space for military purposes should be halted, and that a general agreement should be reached on the peaceful use of outer space by the various countries. The RCP has hailed, through the authorized voice of its secretary general, Comrade Nicolae Ceausescu, the fact that the Soviet Union and the United States have agreed to resume talks on a mutually acceptable accord on the entire complex of problems concerning nuclear and space weapons. The resumption of negotiations between the USSR and the United States will constitute an important factor for disarmament and peace. Our party and state have supported, and continue to support the important proposals advanced by the general secretary of the CPSU Central Committee, Comrade Konstantin Chernenko, on disarmament and on halting the militarization of outer space.

In view of the unprecedented worsening of the international situation, of the increased danger of a new world war and of a nuclear catastrophe that can destroy human civilization and the very conditions of life on our planet, it is more necessary than ever that the other European countries do not remain passive, but participate in the negotiations in some suitable form. We also believe that the revolutionary, progressive, and anti-imperialist forces everywhere, and all the nations, should unite their efforts and intensify their struggle to stop this dangerous course of events leading to confrontation and war, and the struggle for disarmament, primarily nuclear disarmament, and for safeguarding peace. In our opinion, the magazine can contribute to highlighting the very serious dangers threatening the world and the disastrous consequences of the arms race for people's development and life, simultaneously acting to unite all the progressive political and social forces and the broad mass movements in Europe and on other continents for peace and disarmament.

In view of the particularly important role currently played by communist and workers parties in international life and in the peoples' great struggle for peace, independence, and socioeconomic progress, consistent efforts must be made to strengthen their solidarity and cooperation. The complex contemporary problems require that everything possible be done to overcome disagreements, strengthen solidarity, and achieve a new unity, based on equality and non-interference in internal affairs and on respect for the right of each party to independently map out its political line, in keeping with the historical, national, and social conditions prevailing in each country. It is precisely in view of the above that one of the primary obligations of the magazine is to contribute to asserting the principles of interparty relations and to consolidating the cooperation and solidarity of the communist and workers parties on a new basis.

For that purpose, the magazine should do everything possible to promote and support the cause of strengthening the unity, cooperation, and solidarity of the parties. We are convinced that it is in the interests of this cause that

the magazine should be governed by this requirement to a greater extent, and that it should more boldly and perseveringly promote a frank and constructive dialogue--in democratic conditions of mutual esteem and respect--and fully exercise its function as a forum of free exchanges of views, information, and experience.

At the same time, through the means at its disposal, the magazine can militate more consistently for strengthening cooperation among all the forces that are in favor of progress, socialism, and peace. In our times, cooperation between communist and workers parties, and socialist and social-democratic parties is a vital necessity for the progress and independence of the peoples, for disarmament, and for peace throughout the world. Similarly, extensive cooperation with national liberation movements and with progressive parties in the countries that have shaken off the yoke of imperialist domination and embarked upon the path of free and independent development, constitutes an important factor in the struggle against imperialism and neocolonialism, and for consolidating the independence and progress of each nation.

In the past years, the magazine has increased its endeavors to present the situation in Asian, African, and Latin American countries, and the activities and experiences of the struggle waged by revolutionary and democratic forces on those continents. However, the interests of social progress and of building a better and more just world require that the magazine give more space to the struggle of progressive forces and of people in developing countries to eliminate underdevelopment, colonialism, and neocolonialism, and to establish a new world economic order, based on equality, equity, and mutual advantage. In order to overcome the current economic crisis, stabilize and harmoniously develop the world economy, permit the development of each nation along the path of progress, and promote a policy of detente, cooperation, and peace, it is objectively necessary to support efforts aimed at eliminating underdevelopment, solving the acute economic-financial problems at world level, and achieving a new world economic order.

In the current conditions, when there is a great diversity in thought trends and in the interpretation and analysis of the complex problems of social development, it is extremely important that Marxist-Leninist thinking should take a more active part in confrontations of ideas at international level. Let us more intensively promote an extensive dialogue and exchanges of views among the communist parties and between them and other revolutionary and workers forces, national liberation movements, and other progressive and democratic political groups, as well as with representatives of progressive contemporary social thinking. Such activities can contribute to the development of revolutionary theory and practice, and to strengthening the cooperation, mutual understanding, and solidarity of all progressive forces.

As far as it is concerned, as Comrade Nicolae Ceausescu stressed at the recent party congress, the RCP will further resolutely militate for promoting an extensive exchange of views and experience, and developing relations of solidarity and cooperation with all communist and workers parties, and with revolutionary, progressive, and anti-imperialist forces everywhere. We believe that in the current international conditions, strengthening the cooperation of all these forces and their united struggle constitutes a decisively important factor for democratically resolving mankind's problems in keeping with the interests of the peoples, and for peace and social progress.

YUGOSLAVIA

VETERANS' FEDERATION OFFICIAL ON NATIONALISM

LD032052 Belgrade TANJUG Domestic Service in Serbo-Croatian 0625 GMT 3 Mar 85

[Excerpts] Belgrade, 3 Mar (TANJUG)--Nationalism is the greatest threat to Yugoslavia. This is so not only because it reminds us of numerous past conflicts and a time which we hope will never return again, but also because it poses a direct threat to the country's unity, integrity, independence, and survival. Forces of different ideological hues are rallying under the flag of nationalism. Their common goal is to destroy all that we have so far achieved. This is why the Presidium of the SUBNOR [Federation of Veterans' Association] Federal Council recently discussed nationalism and why we are constantly advocating a decisive fight against this social evil, Vlado Scekcic, famous revolutionary, people's hero, and member of the SUBNOR Presidium, said during his talk with TANJUG journalists.

The increasingly frequent nationalist excesses in many of our towns and cities bear out that we are not really conscious of the truth that, as a poet once put it, nobody from outside can harm us but that we ourselves are capable of doing it. Let us take the example of Split. It is a city of workers and war veterans, a real Yugoslav city. And it was precisely in a city like this that a group of hooligans succeeded in imposing itself on the city's young people. Subsequent surveys produced disturbing results: over 28 percent of the young people in Split said that there was no equality of nations and nationalities in Yugoslavia.

Commenting on this result, Vlado Scekcic described it as totally irrational. He said: I think that there is no country in the world which provides for the equality of its people as much as does Yugoslavia. And this is logical, since our equality is the basis of both present-day and future Yugoslavia. It is not an artificially created equality but an equality cemented by our blood lost in the war and revolution. So what, then, is happening with a section of our youth, 40 years after the beginning of socialism? Why does it have such a view of our society? The answer is this: Because of all our divisions, isolationism, and insularity, our young people cannot find their bearings. Their horizon has been narrowed to "their own" republic or province. Disintegration starts as early as primary school, in educational programs: literature, history, and other social areas, such as the economic sphere. In such a situation, Scekcic stresses, young people easily succumb to local influences and find it difficult to defend vigorously all that can be described as Yugoslav.

So, our social situation should primarily be blamed for the nationalism among the young. Therefore, said Scekic, I think that our struggle against nationalism must be simultaneously conducted on two fronts. On the one hand, we must fight against those who favor or carry out these excesses, and on the other hand we must fight ourselves, our own weaknesses. The crisis in our country has, objectively speaking, created an opportunity for all those who are against socialism and Yugoslavia to raise their heads. However, it does not seem to be proper or attractive anymore to constantly talk about our situation. The war veterans spent a lot of time discussing it; we did not worry about our careers or positions. We remained faithful to our revolution; we did not have any other choice. However, our warnings have not always been favorably received either by some leaderships or individual officials.

All our previous assessments of the situation have been borne out by the all-party debate on the draft conclusions of the 13th session of the LCY Central Committee. Communists and other working people call for more efficient action and demand that the process for reaching agreement be accelerated. Scekic added: I am amazed that so much time is being spent discussing what should be put in the conclusions and what should not. It is important that we not wait until the congress to change things; it should be done now. Time is not on our side. People are calling for the leadership, particularly the LCY Central Committee, to show unity and resoluteness. Everybody is getting tired of the different interpretations of unanimously adopted stands.

For my part, Scekic stresses, I could not accuse anybody in the party leadership or other leaders in the country of being nationalist. However, it is a fact that some aspects of their behavior provide "grist for the mill" of nationalism. Republican, provincial, and other kinds of etatism have divided this country into every imaginable sphere: there is tremendous resistance to the process of integration. Noises are being made about dangers of centralism and unitarism. There is no doubt, Scekic says, that any kind of "-ism" is dangerous, but nationalism is definitely the most dangerous one, if for no other reason than this: Yugoslavia's integrity and its self-managing course must be preserved. No one of our republics or provinces could exist on its own outside Yugoslavia. These officials who lack the will and strength to put into practice their forum's decisions must make way for the young. If they do not do so of their own accord, they should be dismissed.

Nowadays many people become enraged at the very mention of the words Yugoslavism and Yugoslavia. They want to replace patriotism for Yugoslavia's nations and nationalities with Yugoslav patriotism. What does this mean? Who is against it? Only the shortsighted and those who are full of ill will could be against it. I think, Scekic stresses, that Yugoslavism poses no threat whatsoever. It might just be that those who declare themselves Yugoslavs would at least enjoy equality.

Scekic was asked: What is your view of the "national reconciliation" thesis? That slogan, Scekic stresses, is not only reactionary but extremely dangerous as well. How can there be any reconciliation between revolution and counter-revolution? That is impossible. That is what sacrifices were made for and will be made again, if need be. For that reason, just denouncing the slogan



will not do. It has to be confronted in a more vigorous manner. This does not, of course, imply that children should be called to account for the crimes of their fathers. On the contrary, we have a duty to treat and accept these children as we would our own. And that is precisely what we are doing.

Scekic was asked: It seems that sometimes we ourselves encourage nationalism through administrative measures; what do you think about it? I think, Scekic said, that you are right. You know, it is very easy to ban something; not much intelligence is needed for that. However, the consequences are inevitably much more serious. We lack professional and social criticism which could illuminate the good and bad points in a work of art. People are often confused about why a book should be banned or a play removed from the repertoire, particularly in cases where the same work of art is unacceptable in one republic and acceptable in another. We forget that one can learn from bad examples as well, as long as they do not insult certain feelings, in which case they cannot be ignored.

What are the duties of war veterans in this fight against nationalism? In view of their moral and political reputation, our veterans are dutybound to exert their influence and show their Yugoslavism when common interests are at stake. We must fight against isolationism and selfishness and for solidarity and Yugoslav interests. That is the way to build mutual trust and to prevent incidents and hatred. It is the veterans' duty, but their right as well, to suppress centrifugal forces in our society and to turn the wheel in the other direction. It is essential that an atmosphere be created in which all those who look after only their own interests, to the detriment of the entire country, will feel ashamed of their behavior, Vlado Scekic said.

CSO: 2800/246

YUGOSLAVIA

BELGRADE LC COMMISSION CRITICIZES 'POLET' ADVENTURISM

Zagreb DANAS in Serbo-Croatian 5 Feb 85 pp 22-23

[Excerpt] At a January meeting of the commission dealing with the [public] information media in the Belgrade city LC, Radoslav Kljajic, political commentator of POLITIKA, tried to answer the question of who is bringing ideological confusion into society and the LCY. He said that there are politicians who do not trust anything that is new or that is challenging [or]...if it has not been said and repeated a thousand times in the past. Changes for them mean the danger of losing secure privileges. Thus, the past, present, and future are separated in an unacceptable way. So in accord with these divisions and local interests, the thesis is brought out that we have achieved the revolution thanks to the complete independence of republic and provincial organizations. Kljajic said these assertions are only a step away from the assumption that our peoples and nationalities have moved into the flight to defend their autonomy and not to support a new Yugoslavia based on equality.

A large number of the discussants agreed with Kljajic's criticism regarding the editorial adventurism of the Zagreb [publication] POLET. Thus, in the race for sensationalism and the desire to "pass the buck" to the Belgrade press, POLET published the speech by Antonije Isakovic given a few months ago and the discussion of Matija Beckovic and Ljuba Tadic at the Serbian Writers Association. Kljajic asked; What does the POLET thesis mean that everything should be published, including completely unacceptable views, so that one can polemicize with them? Then Stipe Oreskovic, president of the Croatian Youth League Conference, as he polemicizes with Isakovic, repeating his views, says that such views served as an inspiration to those who sang Ustashe songs in Split.

Zivorad Djordjevic believes that dialogue with the opposition [e.g., Isakovic, et al] is politically compromising and can be used by the forces of the 'status quo.' "I am convinced that it is the biggest success for our opponents if we attack them. It would be no success for them if we ignored them. But, nevertheless, provocations are being made and it is asked: Why does the Belgrade press not react to these excesses, why does it almost cover them up? And when the affair blows up, then it is difficult to judge which is better: to raise a fuss and thereby also increase the importance of such persons or not to do this and be in danger of being called names.

Vjislav Micovic found it symptomatic that everything negative from other areas is being carefully noted [in Zagreb] and passed on, but not for purposes of integrating the information media with the entire Yugoslav area, but for malicious reasons. Dusan Mitevic also was critical of POLET's publication of the Isakovic text, while Jovan Kakicevic asked: "I do not know what need there is to extract...speeches from discussions held at meetings in Belgrade and to give them wide publicity in publications outside of Belgrade. If the reason is to polemicize with them, of course this is not difficult since it is a question of views not socially acceptable, but this is too big a price to pay for such a risk. It is, at any rate, a question of differing views of the role of the press and the journalist's calling...."

CSO: 2800/255

27 March 1985

YUGOSLAVIA

## BLAZEVIC'S BELATED 'REVELATIONS' ON STEPINAC TRIAL

Frankfurt/ Main FRANKFURTER ALLGEMEINE in German 8 Mar 85 p 8

[Article by Viktor Meier: "Blazevic 'Revelations' Make Yugoslav Leaders Look Foolish"]

[Text] Vienna, 7 March--In Croatia, whose leadership has thought of itself over the past several years as the keeper of the grail of "pure Titoism", serious factional disputes with possibly far-reaching consequences have broken out almost overnight. The opening shot was fired by Jakov Blazevic, a former head of the republic and erstwhile prosecutor in the trial against Cardinal Stepinac, the archbishop of Zagreb during the war years and the postwar era. Blazevic, writing in the Zagreb youth organ POLJE recently, stated that the 1946 Stepinac trial was "forced upon" the regime. If the archbishop had displayed "greater flexibility," it would never have taken place. In particular, Stepinac should have acceded to Tito's wishes for a separation of the Croatian church from Rome and the Papacy.

This "revelation" by the aging Blazevic was bound to make the Croatian leadership look bad right off. First of all, the Blazevic statement amounted to an admission of the fact that the trial was improperly conducted and secondly, it now seemed that Tito had raised demands with the archbishop which the latter could not in good conscience meet. In this sense then, Stepinac was officially being declared an innocent man. The anti-clerical spear carriers within the ranks of the regime soon realized what damage their advance man Blazevic had done. Ivankovic, a party expert in church matters from Zagreb, writing in the magazine DANAS, rose to Tito's defense who, he said, had never asked Stepinac for anything of the sort. The Croatian partisan fighters association, whose darling Blazevic had always been, now accused him of besmirching Tito's memory.

From the point of view of historical truth, Blazevic has scarcely right. All in all, to be sure, the Stepinac trial was a production of the political police. The fact that some randomly arrested functionary of the former Ustasha state, rather than the archbishop himself, had to serve as the main defendant provides ample evidence of that. Even the "official" historians in Zagreb hardly use the indictment as a source any longer.

The truth is that Tito himself was the director of the piece and that Blazevic merely carried out his orders. This would turn the revision of the proceedings into a politically explosive affair. Tito, at any rate, never asked for a separation of the Croatian church from Rome. After the war, in a conversation [with Stepinac], he merely suggested a bit more "distance." Most historians tend to agree that the reason for the arrest and sentencing of Stepinac was that by resisting the regime he had become the focal point of all the forces which opposed the communist government's efforts to make them toe the line. There were a good many forces of this kind at the time, even within the communist ranks themselves. Even though his theories are only partially true, Blazevic would seem to have punctured the regime's anti-Stepinac myth for all time.

Mika Spiljak, the head of the party in Croatia, working for consensus and moderation but often relegated to an isolated position as a result, provided a first, relatively frank account of the events leading to the removal and expulsion from the party of the then interior minister of the republic, Gazi, a little more than a year ago. His revelations not only served to incriminate the dismissed functionary but also the entire political police apparatus of the republic and possibly some political figures who backed it. Spiljak revealed that Gazi orchestrated a number of affairs in the two large Croatian enterprises of Podravka and Ina in the course of which a great many people were unjustly accused of wrongdoing and arrested. Some were forced to make untrue confessions while others knowingly gave false testimony. Spiljak said that the time had come to tell the people the truth. In view of the enormous accusations, it is surprising that those responsible are not being prosecuted. Against the background of these actions on the part of the police, the Zagreb trials of so-called dissidents--such as Gotovac, Veselica, Paraga and others--appear in a new light. It is said that it was Vrhovec, the current Croatian representative on the Yugoslav state presidium, who protected the then interior minister Gazi for some time.

Disputes are also reported to have broken out among the group centering on Bilic and Zagreb chief ideologist Suvar which had raised the banner of purifying Marxist ideology throughout Yugoslavia. At the recent writers' congress, writer and critic Mandic said that the writers association did not cover itself with glory by not reacting last year when Suvar compiled his "White Book" listing Serbian and Slovenian writers alleged to be in opposition to the regime. In an ironic comment, the Belgrade magazine NIN wrote that Mandic appeared to have many supporters inside the hall, though not on the speaker's rostrum. Babic, an aide-de-camp of ideology chief Suvar, jumped up and accused Mandic of being a liar and an unreliable individual. But this was too much even for the editor-in-chief of the magazine DANAS whom Bilic and Suvar placed into that job just recently so that a "Belgrade-type situation" would not arise in Zagreb. He criticized Babic vehemently, albeit on a different

matter so that now no one in Zagreb knows any more which two people are allies and which two are enemies.

Dragosavac and Baltic, the two Serbians on the Croatian party leadership, both known for their dogmatic stand, have become involved in an argument with the Serbian party organization in Belgrade. Dragosavac was violently attacked by NIN's editor-in-chief for making wild and **anonymous charges** at a meeting in Skopje, as he often does. And Baltic is increasingly being thrown on the defensive with his theory that any change in the economic system amounts to "counterrevolution." Even Prof Korosic, a political economist from Zagreb, has now mustered the courage---in the pages of NIN, to be sure---to lay most of the blame for the present economic woes of Yugoslavia on that very economic system.

9478

CSO: 2300/322

END