

049287

JPRS-UMA-85-063

22 November 1985

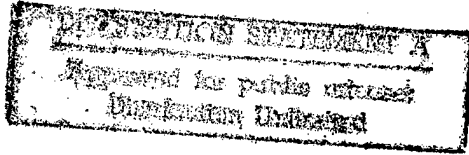

19981105 063

# USSR Report

MILITARY AFFAIRS

MILITARY HISTORY JOURNAL

No 6, June 1985

DTIC QUALITY INSPECTED 8

**FBIS** FOREIGN BROADCAST INFORMATION SERVICE

Reproduced From  
Best Available Copy

9  
76  
A05

## NOTE

JPRS publications contain information primarily from foreign newspapers, periodicals and books, but also from news agency transmissions and broadcasts. Materials from foreign-language sources are translated; those from English-language sources are transcribed or reprinted, with the original phrasing and other characteristics retained.

Headlines, editorial reports, and material enclosed in brackets [ ] are supplied by JPRS. Processing indicators such as [Text] or [Excerpt] in the first line of each item, or following the last line of a brief, indicate how the original information was processed. Where no processing indicator is given, the information was summarized or extracted.

Unfamiliar names rendered phonetically or transliterated are enclosed in parentheses. Words or names preceded by a question mark and enclosed in parentheses were not clear in the original but have been supplied as appropriate in context. Other unattributed parenthetical notes within the body of an item originate with the source. Times within items are as given by source.

The contents of this publication in no way represent the policies, views or attitudes of the U.S. Government.

## PROCUREMENT OF PUBLICATIONS

JPRS publications may be ordered from the National Technical Information Service (NTIS), Springfield, Virginia 22161. In ordering, it is recommended that the JPRS number, title, date and author, if applicable, of publication be cited.

Current JPRS publications are announced in Government Reports Announcements issued semimonthly by the NTIS, and are listed in the Monthly Catalog of U.S. Government Publications issued by the Superintendent of Documents, U.S. Government Printing Office, Washington, D.C. 20402.

Correspondence pertaining to matters other than procurement may be addressed to Joint Publications Research Service, 1000 North Glebe Road, Arlington, Virginia 22201.

Soviet books and journal articles displaying a copyright notice are reproduced and sold by NTIS with permission of the copyright agency of the Soviet Union. Permission for further reproduction must be obtained from copyright owner.

22 November 1985

USSR REPORT  
MILITARY AFFAIRS

MILITARY HISTORY JOURNAL

No 6, June 1985

Except where indicated otherwise in the table of contents the following is a complete translation of the Russian-language monthly journal VOYENNO-ISTORICHESKIY ZHURNAL.

CONTENTS

The Embodiment of Lenin's Ideas Concerning the Defensive of the Socialist Fatherland During the Years of the Great Patriotic War (pp 3-9) (Editorial) (not translated)	
SOVIET MILITARY ART	
Support for the Flanks of Assault Groupings of Fronts During Offensive Operations (pp 10-16) (S. I. Gladyshev) . . . . .	1
Naval Forces Coordination to Interdict Sea Communications (pp 17-25) (V. P. Alekseyev) . . . . .	11
Organizing 'Operational Rear' During World War II (pp 26-32) (N. A. Malyugin) . . . . .	21
DOCUMENTS AND MATERIALS	
Documents on 'Liberation' of Northeast Areas (pp 33-36) (Col I. V. Yaroshenko, L. I. Smirnova) . . . . .	30
PARTY POLITICAL WORK	
An Important Weapon of Victory (pp 37-45) (M. I. Burtsev) (not translated)	
MEMOIRS AND ESSAYS	
We Rush to the Wounded (pp 46-51) (M. F. Gulyakin) (not translated)	

SCIENTIFIC PAPERS AND INFORMATION

On Work Methods of All-Arms Commanders, Staffs in Organizing Offensive  
Combat in 1930's (pp 52-57)  
(V. O. Daynes) . . . . . 37

Combat of Dnieper Naval Flotilla in Belorussian Operation (pp 57-62)  
(A. P. Aristov) . . . . . 47

Weapons Supply of Fronts in Berlin Operation (pp 62-63)  
(I. I. Volkotrbenko) . . . . . 54

AGAINST THE BOURGEOIS FALSIFIERS OF HISTORY

The Falsification by Bourgeois Historians of the Results and Lessons of  
the Great Patriotic War (pp 64-70)  
(N. K. Glasunov) (not translated)

MILITARY HISTORY DATES

An Invincible Fortress of the Revolution (pp 71-75)  
(L. A. Zaytsev) (not translated)

Revolutionary Activities of N. V. Krylenko in the Army (pp 75-77)  
(V. M. Shabanov) (not translated)

Mar Art Yu. P. Bazhanov (pp 78-79)  
(P. N. Kuleshov) (not translated)

CRITICISM AND BIBLIOGRAPHY

Review: Gareyev on Frunze (pp 80-86)  
(A. A. Danilevich) . . . . . 57

Review: Khametov Book on Adm Golovko (pp 86-87)  
(S. Ye. Zakharov) . . . . . 67

HISTORIOGRAPHY AND BIBLIOGRAPHY

Recent Works on Warsaw Pact (pp 88-89)  
(I. I. Shinkarev) . . . . . 70

YOU ASK AND WE ANSWER (pp 90-92)  
(Unattributed) (not translated)

CURRENT EVENTS, FACTS, FINDINGS (pp 93-96)  
(Unattributed) (not translated)

10272  
CSO: 1801/272

SUPPORT FOR THE FLANKS OF ASSAULT GROUPINGS OF FRONTS DURING OFFENSIVE OPERATIONS

Moscow VOYENNO-ISTORICHESKIY ZHURNAL in Russian No 6, Jun 85 (signed to press 28 May 85) pp 10-16

[Article by Candidate of Military Sciences, Col (Ret) S. A. Gladyshev under the rubric "Soviet Military Art"]

[Text] In the course of the Great Patriotic War, the efforts of the main mass of men and weapons on the offensive side were concentrated on the axis of the front's main thrust while the regrouping of them in the course of the operation toward the threatened flank, if this was not planned previously, involved great difficulties, particularly with extended and shallow battle formations. As a consequence of this the flanks of the assault groupings were the most vulnerable.

The advancing troops were often deprived of the possibility of reinforcing their flanks, particularly in those instances when the main forces were tied down by the enemy on the front. In the course of pursuit, such a situation arose in line with the lack of units and formations assigned to cover the flanks. For this reason support for the flanks of the assault groupings in the course of offensive operations was one of the main tasks for the commanders of the fronts and their staffs.

An analysis of the offensive operations during the first period indicates that the command and the staffs of the fronts did not pay sufficient attention to the questions of supporting the flanks of the assault groupings. In the first place, it was not always possible to assign the necessary men and weapons for this. Secondly, their size, missions and procedure for cooperation were often not established ahead of time. In a majority of instances the questions of supporting the flanks were examined hurriedly, with a direct threat of enemy attack. All of this at times led to the incompleteness of the advance or to its aborting.

In the Barenkovo-Lozov Operation of the Southwestern and Southern Fronts (January 1942), their assault groupings broke through the enemy defenses and in 4 days of fighting had advanced up to 25 km in depth. However, measures were not promptly taken to support the flanks of the breakthrough sector. In truth, in the operational plan of the Southwestern Front (commander, Lt Gen

F. Ya. Kostenko) provision was made to leave two rifle divisions on the flanks of the 6th Army, but specific missions were not given to them to establish defensive screens. As a consequence on the flanks of our assault groupings the situation began to become rapidly more complex. The enemy, in firmly holding the areas of Balakleya and Slavyansk, was able to reinforce its troops around the breakthrough base, it put up stubborn resistance there and created a dangerous threat for the Soviet troops. The command of the fronts was forced in the course of the operation to leave a portion of the forces from the assault groupings on the flanks and this naturally weakened them. The rate of advance of the troops began to drop and ultimately the successfully commenced offensive did not get any farther.(1)

In the Lyuban Operation (January-April 1942), an assault grouping consisting of the 2d Shock Army (commander, Lt Gen A. Ye. Klykov), on a narrow sector broke through the enemy defenses along the western bank of the Volkhov River and during February advanced 75 km in depth. But the enemy, having concentrated up to five infantry divisions along the base of the breakthrough in the areas of Spasskaya Polist and Lyubtsy, with air support launched strong counterstrikes from the north and south against the flanks of the army and cut its main lines of communications.

Subsequently, the commanders and staffs of the fronts gained experience in supporting the flanks of the assault groupings. In the interests of carrying out this mission, certain men and weapons were assigned and they were given specific missions and carefully organized for cooperation. For example, during the counteroffensive at Stalingrad, the right flank of the Southwestern Front (commander, Lt Gen N. F. Vatutin) was supported by three rifle divisions of the 1st Guards Army (commander, Lt Gen D. D. Lelyushenko) and four rifle divisions from the 5th Tank Army (commander, Lt Gen P. L. Romanenko). These formations, having broken through the enemy defenses and broadened the breakthrough, then initiated an offensive toward the line of the Chir, Krivaya Rivers, where a defensive screen was established (in the operational plan this was termed the support front). When the enemy, having moved up four infantry and motorized divisions into the area of Bakovskaya, began to threaten the right flank of the front's assault grouping, the Soviet troops by a strong active defensive thwarted its attempts to prevent the completion of the encirclement of the large enemy grouping to the west of Stalingrad.(2)

As was pointed out MSU A. M. Vasilevskiy, in preparing the counteroffensive at Stalingrad at meetings of the leadership of the Southwestern, Don and Stalingrad Fronts and their armies on the 3d, 4th and 10th of November 1942, a procedure was worked out in detail for supporting the flanks of their assault groupings.(3)

In breaking through the defensive, the enemy usually endeavored to halt the advance in depth of the advancing groupings by attacking their flanks, to isolate the second echelons and reserves and prevent the development of the offensive. Depending upon the situation, the enemy counterstrikes were checked by various methods. For example, of interest is the support for the flanks of the assault groupings of the Leningrad Front (commander, Lt Gen L. A. Govorov) and the Volkhov Front (commander, Army Gen K. A. Meretskov) in breaking through the Leningrad blockade in January 1943. In order to cover

the right flank of the assault grouping of the Leningrad Front, in the 67th Army of Maj Gen M. P. Dukhanov, they planned a barrage fire curtain on the sectors of two Nazi infantry divisions toward Mustolovo, Kelkolovo.(4) For establishing this, 18 artillery and mortar regiments as well as 7 rocket batteries were assigned and these were moved up during the 3d-4th day of the offensive to the east bank of the Neva River.(5)

Support for the left flank of the assault grouping of the Volkhov Front was entrusted to the 8th Army (commander, Lt Gen F. N. Starikov). Its right flank formations sealed off the powerful enemy defensive centers at Gatolovo and Torolovo, they tied down enemy reserves and blocked its counterstrikes from the south.(6)

In the Iasi-Kishinev Operation, support for the right flank of the assault grouping from the Second Ukrainian Front (commander, Army Gen R. Ya. Malinovskiy) was assigned to the 7th Guards Army (commander, Col Gen M. S. Shumilov) and the Cavalry-Mechanized Group (commander, Maj Gen S. I. Gorshkov). In utilizing the gap in the area of the 27th Army of Lt Gen S. G. Trofimenko, they developed an offensive around the Tirgu-Frumos Fortified Area and rolled up the enemy defenses.(7)

In committing the mobile groups of the fronts to a breakthrough, the support for their flanks, as a rule, was entrusted to the all-arms formations and field forces fighting in the area of the commitment. For example, in the Korsun-Shevchenkivskiy Operation (January-February 1944), the flanks of the mobile group to be committed to the breakthrough of the Second Ukrainian Front, the 5th Guards Tank Army (commander, Col Gen Tank Trps P. A. Rotmistrov), were supported by the troops of the 4th Guards Army (commander, Maj Gen A. I. Ryzhov) and the 53d Army (commander, Lt Gen I. V. Galanin). These established strong defensive screens and made skillful use of artillery fire and air strikes. The mobile obstacle construction detachments mined the terrain on the sectors of enemy actions.

Valuable experience of supporting the flanks in committing the mobile group to the breakthrough of the First Ukrainian Front (commander, MSU I. S. Konev) comprising the 3d Guards Tank Army (commander, Col Gen Tank Trps P. S. Rybalko) and the 4th Tank Army (commander, Col Gen D. D. Lelyushenko) was gained in the Lwow-Sandomierz Operation. These armies were to successively literally "squeeze their way" deep into the enemy defenses across a 6-km "Koltow Corridor." The commitment was made under conditions where on the southern face of the corridor covered by troops from the 38th Army of Col Gen K. S. Moskalenko, starting from the second day of the operation, the enemy continuously operated from the area of Zborow, where it had concentrated a strong counterstrike grouping (see the diagram).

For supporting the flanks of the tank armies to be committed to the breakthrough, the command and staffs of the front moved up the IV and XXXI Tank Corps here.(8) On the threatened sectors, in addition, they quickly concentrated five antitank brigades (more than 400 guns) and a self-propelled artillery brigade from the 3d Guards Tank Army. This made it possible to establish an antitank artillery density up to 50 guns per kilometer of front.(9)

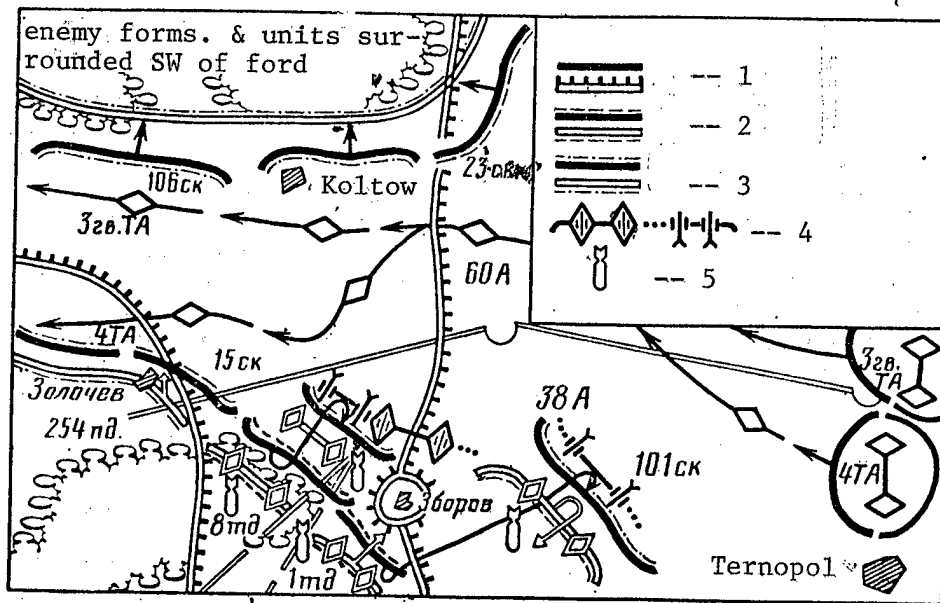

Commitment of Mobile Group From First Ukrainian Front to Breakthrough

- Key: 1--Position of troops by end of 15 July 1944  
 2--Position of troops by end of 16 July 1944  
 3--Position of troops by end of 18 July 1944  
 4--Deployment line of self-propelled artillery brigade, antitank artillery brigade and mobile obstacle construction detachment  
 5--Air strikes

In addition to establishing a firm screen on the southern flank of the mobile group, upon the decision of the front's commander, on 16 July, the 1st Guards Army began an offensive and it broadened the breakthrough and finally checked the enemy's plan to use its Zborov counterstrike grouping.(10)

The experience of the war showed the important significance of dependable support for the flanks of the mobile groups fighting deep in the enemy defenses a significant distance away from the main forces. In particular, in the Berlin Operation, according to instructions from Headquarters Supreme High Command [Sq SHC], two tank armies which made up the mobile group from the First Ukrainian Front, on 14 April 1945, were turned to hit Berlin from the south. According to the plan of the front's commander, MSU I. S. Konev, during the night of 21 April by a forced march on the front's motor transport, two rifle divisions from the 28th Army of the front's second echelon were shifted and these covered the flank of the 3d Guards Tank Army against attacks by the Frankfurt-Gruben enemy grouping.(11)

Often in the second and particularly in the third periods of the war, the Nazis, being unable to prevent the breakthrough of the tactical defensive zone by the Soviet troops, endeavored to actively operate on the flanks of the assault groupings in the course of developing the offensive in the operational depth. Thus, in the Belgorod-Kharkov Operation, the Nazi Command



by 18 August had concentrated in the Akhtyrka area three tank and one motorized divisions for a counterstrike against the right flank of the assault grouping from the Voronezh Front. Under the existing situation the commander, Army Gen N. F. Vatutin, to the north and northeast of Akhtyrka committed to battle the 47th Army (commander, Lt Gen P. P. Korzun) and the 4th Guards Army (commander, Lt Gen G. I. Kulik) and these armies launched an attack in the flank of the enemy grouping.(12) Aviation played an important role in its defeat. In the Akhtyrka area alone, pilots from the 2d Air Army in 3 days of combat destroyed over 30 enemy tanks and 400 motor vehicles and neutralized several artillery and mortar batteries.(13) Due to the measures taken, the attempts by the Nazi Command to abort the offensive by the Voronezh troops failed.

Thus, the experience of the Great Patriotic War showed that supporting the flanks of assault groupings was one of the important tasks on the way to achieving the ultimate goals of the front-level offensive operations. The successful carrying out of this task had immediate impact upon the development of the offensive at a rapid pace and to a great depth. In this context, great attention was given to organizing support for the flanks of the assault groupings in the various stages of an operation. Depending upon the missions to be carried out by the troops of the front, the developing balance of forces, the nature of enemy actions and other situational conditions, the flanks of the assault groupings were covered by different methods.

Under conditions where the enemy launched an attack with numerically superior forces against the flanks of the front's advancing troops, in a majority of instances this was repelled by the going over of the formations assigned to cover the flanks to a defensive on advantageous lines.

The field forces and formations with the mission of covering the flanks of an assault grouping in a number of instances carried this out by developing the offensive in depth and toward the flank in the aim of crushing the enemy defenses and broadening the breakthrough area.

In encirclement operations the troops advancing on the flanks of the assault groupings, along with covering their flanks, had the mission of establishing the external perimeter of encirclement.

It must be pointed out that various forces and weapons were involved in supporting the flanks of the assault groupings in the course of offensive operations. As the experience of the war shows, in a majority of instances the main role was played by the all-arms field forces and formations. On them, as a rule, rested the main burden of defeating the enemy groupings which were attacking the flanks.

Aviation carried out important missions in supporting the flanks of the front assault groupings. Along with conducting air reconnaissance it made bombing and strafing attacks against the enemy counterstrike groupings in their assembly areas and during the period of deployment and combat dependably covered friendly troops against air strikes.

**PLAN FOR SUPPORT OF FLANKS OF 42d ARMY**  
(Appendix to Operational Plan)

Men and Weapons for Support	
Sector of Front (flank)	Engineer Troops
1	3
<p><b>1. Army right flank</b></p> <p>Southern bank of Gulf of Finland--Uritsk</p>	<p>4</p>
<p>1. With going over of 42d Army to offensive, 291st Sep. Machine Gun-Artillery Btl. of 79th Fort. Area continues to occupy defenses on forward edge in front of Uritsk.</p> <p>With freezing over of Gulf of Finland one artillery-machine gun company is moved up to the coast with the mission of preventing the outflanking of the right flank of the 291st Sep. Machine Gun-Artillery Btl. across the ice of the Gulf of Finland.</p> <p>As a total on the front from the Gulf of Finland to Uritsk there will be: 20 antitank guns, 12 mortars, 32 medium machine guns, 7 submachine guns, 32 light machine guns; a total of 470 men.</p> <p>Fire density/lin. m of front is 5.2 rounds. Subsequently flank is supported by 109th Rif. Div. advancing on the army right flank.</p>	<p>2</p>
<p>Artillery support for right flank will be provided by:</p> <p>404th Art. Reg: 8 batteries of 32 guns, 1300th How. Art. Reg. with 7 batteries of 28 guns, 1229th How. Art. Reg. with 7 batteries of 28 guns, 1st Btl. of 51st Can. Art. Brig. with 3 batteries of 12 guns. 12th Guards Art. Reg. with 6 batteries of 24 guns.</p> <p>Total: 31 batteries of 124 guns.</p> <p>Density/km of front: 31 pieces. The fire plan existing ahead of the forward edge (fixed, moving, barrage and concentrated fire) remains unchanged and is supported with the going over of the 42d Army to the offensive by the artillery of the 109th Rif. Div., the 1300 and 1229th How. Art. Regs., the 12th Guards Art. Reg., the 1st</p>	<p>3</p>
<p>1. Minelaying of forward edge to north and east of Uritsk consists of 3-4 rows of pressure-activated antipersonnel mines.</p> <p>On main likely tank approaches (along roads) antitank mines have been set (up to 15 rows, deeply echeloned); antitank mines raised to ground surface before snowfall.</p> <p>By start of operation (preparatory period) the following will be set:</p> <p>a) Trip-wire antipersonnel mines (POMZ-2) ahead of the forward edge on the front: the shore of the Gulf of Finland, Uritsk and along the Sea Canal to Kamennaya Embankment (in 2 rows); b) Antitank mines in 2 rows on all likely tank approaches.</p> <p>2. For reinforcing the 109th Rif. Div. with man-made obstacles during the period of combat the following are to be assigned:</p>	<p>4</p>

1	2	3	4
<p>2. Army left flank Boundary with 67th Army</p>	<p>2. In carrying out its task the 109th Rif. Div. on the consolidation line establishes the defensive centers in the areas: Ligovo Station, the triangle of railroads, the platform Tol 500 m to the west of Sosnovka, the mound with an elev. +2.5 with the task, in firmly holding the captured line, of covering the right flank of the army in the event of enemy counter-attacks from Uritsk.</p> <p>1. With going over of the 42d Army to offensive, the 84th Rif. Reg. of 56th Rif. Div. with the 267th and 289th Sep. Machine Gun-Artillery Btlns. of the 79th Fort. Area continues to occupy defenses on forward edge of front Bol. Kuzmino, elev. 16.8, supporting boundary with 67th Army.</p> <p>As a total on the front of Bol. Kuzmino, elev. 16.8 there will be: 40 antitank guns, 51 mortars, 74 medium machine guns, 100 light machine guns and 466 submachine guns. Active bayonets 1,902. Total of 2,195 men.</p>	<p>Btln. of the 51st Can. Art. Brig. Antitank defense is organized by artillery from rifle regiments of 109th Rif. Div. Artillery support for left flank of boundary with 67th Army will be provided by: One btln. from the 113th Art. Reg. with 3 batteries of 12 guns, 8th Corps Art. Reg. with 4 batteries of 16 guns, 73d Corps Art. Reg. with 9 batteries of 17 guns, 479th How. Art. Reg. with 5 batteries.</p> <p>Total of 21 batteries with 66 guns. Density/km of front: 9.4 guns. The fire plan existing in front of forward edge (fixed and moving barrage and concentrated fire) is to remain as before and is to be supported by designated artillery of the 86th Rif. Div. Antitank defenses are to be organized by artillery from rifle regiments of 86th and 56th Rif. Divs.</p>	<p>The 580th Engr. Co. from the 7th Guards Mining Btln. and the 30th Electrotechnical Co. In the event of enemy tank counterattacks, subunits from the 7th Guards Mining Btln. are to operate as mobile obstacle construction detachments. Minefields of forward edge ahead of front of 56th Rif. Div. consists of 3-7 rows of antitank mines, 6-10 rows of antipersonnel pressure-activated mines and 2 rows of POMZ-2 (laid in Nov-Dec 1943). Antitank mines are to be raised to ground surface before snowfall on likely tank approaches. For reinforcing existing minefields, at present 2 rows of antitank mines are to be set out along the entire forward edge. For reinforcing the 86th Rif. Div. with man-made obstacles during the period of combat 2 companies are to be assigned from the 9th Combat Engr. Btln. The subunits from the 9th Combat Engr. Btln. with a tank threat are to fight as</p>

1	2	3	4
	<p>Fire density/lin. m of front 1.8 rounds. Subsequently the army left flank will be supported by the 86th Rif. Div. advancing on the left flank of the army grouping.</p> <p>With the capturing of the line: Kovrovo, Kripuzi, elev. 86.3, Soboleva, the Kuzminka River and Bol. Kuzmino, the CX Rif. Corps with the forces of the 85th and 86th Rif. Divs. is to organize the reinforcing of the captured line.</p>		<p>mobile obstacle construction detachments.</p> <p>Moreover, upon completing the mine-clearing work, the companies of the 192d Man-Made Obstacle Btltn. will fight as reinforcements.</p>

Artillery fire also was of important significance in covering the flanks of the assault groupings. With the establishing of antitank reserves they were successfully used as a mobile means for supporting the flanks in breaking through the defenses, in committing the mobile groups and second echelons to combat and in developing the offensive in the operational depth.

The engineer troops in the aim of covering the flanks of assault groupings laid mines on threatened sectors and destroyed bridges, roads and other structures.

Measures to support the flanks of assault groupings in a majority of instances were reflected in the operational plans. They were defined most fully for the period of breaking through the enemy defenses and carrying out the immediate mission.

Sometimes special plans were worked out for the support of the flanks and these were an appendix to the operational plan. For example, such a plan was worked out in the 42d Army (commander, Col Gen I. I. Maslennikov) of the Leningrad Front during the Krasnoselsk-Ropsha Operation (January 1944) (see the document).

All this experience is of great cognitive and practical value and can be used in operational and combat training, certainly, considering the changes which have occurred in weaponry and arming of the troops as well as the particular features of conducting modern operations.

#### FOOTNOTES

1. TsAMO SSSR [Central Archives of the USSR Ministry of Defense], folio 228, inv. 701, file 871, sheets 41-46; folio 251, inv. 646, file 152, sheets 61-65.
2. Ibid., folio 229, inv. 590, file 2, sheets 15, 20; file 5, sheets 68-69.
3. A. M. Vasilevskiy, "Delo vsej zhizni" [A Cause for All One's Life], Moscow, Politizdat, 1974, p 224.
4. TsAMO, folio 217, inv. 1221, file 2139, sheet 38.
5. "Sovetskaya artilleriya v Velikoy Otechestvennoy voyne 1941-1945" [Soviet Artillery in the Great Patriotic War of 1941-1945], Moscow, Voenizdat, 1960, pp 198-199.
6. TsAMO, folio 204, inv. 89, file 1198, sheets 52, 65.
7. "Operatsii Sovetskikh Vooruzhennykh Sil v Velikoy Otechestvennoy voyne 1941-1945" [Operations of the Soviet Armed Forces in the Great Patriotic War of 1941-1945], Moscow, Voenizdat, Vol 3, 1958, pp 444, 476-482.
8. Ibid., pp 383-384.

9. "Sovetskaya artilleriya v Velikoy...", p 482.
10. "Operatsii Sovetskikh Vooruzhennykh...", Vol 3, pp 407-410.
11. I. S. Konev, "Zapiski komanduyushchego frontom" [Notes of a Front Commander], Moscow, Voenizdat, 1981, pp 424-438.
12. "Operatsii Sovetskikh Vooruzhennykh...", Vol 2, pp 282-283.
13. "Sovetskiye Voenno-Vozdushnyye Sily v Velikoy Otechestvennoy voyne 1941-1945" [The Soviet Air Forces in the Great Patriotic War of 1941-1945], Moscow, Voenizdat, 1968, p 197.

COPYRIGHT: "Voenno-istoricheskiy zhurnal", 1985

10272

CSO: 1801/272

## NAVAL FORCES COORDINATION TO INTERDICT SEA COMMUNICATIONS

Moscow VOYENNO-ISTORICHESKIY ZHURNAL in Russian No 6, Jun 85 (signed to press 28 May 85) pp 17-25

[Article by Candidate of Military Sciences, Capt 1st Rank V. P. Alekseyev: "Cooperation Among Diverse Naval Forces in Interdicting Enemy Naval Lines of Communications (From the Experience of the Great Patriotic War)"]

[Text] A most important condition for the Navy's successful carrying out of the missions confronting it in the course of combat was an employment of its diverse forces whereby the greatest aggregate effect would be achieved as a result of their combined and coordinated actions. For this reason the organization of close cooperation between the various formations, units and subunits held a significant place in the activities of the fleet and flotilla leadership from the very outset of the war. The developing situation brought to the forefront the task of aiding the ground forces. But in addition to this, the naval forces had to carry out many other missions both in the course of daily combat activity as well as in conducting independent operations.

Great attention was given to actions on the enemy sea lines of communications. These included reconnaissance of the sealanes between shore points, the destruction of convoys and individual transports while at sea, attacks against the convoy assembly points and destinations and the laying of active mine defenses.

Employed for conducting reconnaissance were aviation, submarines, surface vessels, shore listening posts and visual spotting posts as well as reconnaissance groups landed on the enemy-occupied coast. The essence of their cooperation here was: in the extensive and effective use of the available resources for quickly obtaining the most reliable information on the enemy and its lines of communications as well as the systematic updating of this information; the constant exchange of valuable information between the diverse forces; the study of the intelligence data by the command of the formations, units and subunits after the information have been generalized and clarified by the naval staff and the use of these data in working out decisions to carry out the next missions of disrupting enemy lines of communications.

Aviation played the main role in conducting reconnaissance. For this rather effective use was made of new type high-speed aircraft, for example the YaK-9.

Beginning in the second year of the war, the proportional amount of aerial photographic reconnaissance began to grow rapidly in the interests of daily fleet operations. This carried out the tasks of aerial photographing of enemy naval bases, ports and airfields, ships and transports at sea, the coast and approaches to it. For example, as a result of aerial photography in the Arctic Theater the base points were established for large German fighting ships (the battleships Tirpits and Scharnhorst and others).(1)

At the start of the war air reconnaissance had a number of major defects which were compensated for in the course of conducting reconnaissance by the submarines, surface vessels and radios. The duplicating or parallel securing of information did not always provide its prompt obtaining and this significantly reduced the effective operations against convoys. A rather frequent error encountered in the reports from aviators was the inaccurate determining of the location of the targets spotted at sea and their classification. While the first error was largely explainable by the primitive nature of navigation equipment, the second was due to insufficient preparedness of the crews of the reconnaissance aircraft and their poor knowledge of the silhouettes of navy fighting ships and vessels.

Another difficulty in organizing cooperation in the course of acquiring intelligence data was the lack of communications between the aircraft carrying out air reconnaissance and submarines located at sea. The information gained by the submarines which for a protracted time had covertly sought out the convoys and tracked them in enemy-controlled areas was frequently the most accurate.

The careful, successive and continuous conduct of reconnaissance as well as the complete employment of the capabilities of the diverse naval forces considering the situation, the condition of the sea channels and the weather conditions brought good results in operating on the enemy sealanes, in particular in destroying its convoys and individual transports at sea. Thus, the Command of the Baltic Fleet even during the very difficult period of the first months of the war was able to organize active combined operations by diverse forces on the enemy sealanes. The complexity of carrying out this mission was aggravated by the fact that the fleet was forced to relocate to the eastern part of the Gulf of Finland and this made it possible for the enemy to strengthen the defenses on its sealanes. For this purpose it carried out widespread minelaying, attempting to seal off our ships, particularly submarines, in Leningrad and Kronshtadt. The enemy achieved a good deal of its plans but was unable to fully isolate the Baltic Fleet. The resistance by the diverse forces from our fleet prevented the enemy from fully achieving its plans.

Indicative was the crossing of the minefields by the submarines.(2) They made all the crossings following a carefully elaborated plan in which an important place was held by cooperation among the various forces. In particular, the plans indicated: the precise coordinates and time for meeting the submarines sent out on missions by their escorts; the composition of the escort groups and their missions at each stage of the crossing; the areas and channels requiring minesweeping as well as what forces would carry this out and when; the number of aircraft assigned for reconnaissance and an air cover for the



submarines and their escorts; the code signals for carrying out one or another joint maneuver.

Tasks were also set for the shore artillery and observation posts. The appropriate commanders and chiefs of staff of the fleet were informed of the time of the passing of the submarines and their courses within the sectors of the artillery batteries and in the area of the posts. In addition the artillery troops were given missions to cover and support the submarines and escort vessels in the event of enemy resistance to their movement.

Measures were also undertaken to cover the submarines returning from active duty. On the east Gogland Reach as well as in the area of Lavensari Island, for example, they were met by escort ships while aviation provided feints and diversionary flights. Usually the fleet staff, in planning these measures, endeavored to combine the meeting of some subs with the escorting of others out of the bases. But such a coincidence was not always achieved since there was no contact with the subs at sea and they often returned later than the designated time. Under these conditions they were often covered by ships and aircraft sent out on patrol. The experience gained in the Baltic convinced us that only successive, systematic and profoundly thought-out cooperation among the diverse forces would make it possible to fight successfully on the enemy sealanes. In truth, objective conditions did not always contribute to its clear organization as there was a lack of men and weapons, while the technical primitiveness or increased activity of the enemy prevented this. Thus, in 1943, the Baltic Fleet Command temporarily abandoned (until the second half of 1944) the use of submarines on enemy sealanes, as it was unable to assign sufficient forces for the submarines to break through the strong defended positions. At this time the mission of disrupting enemy sea movements was basically assigned to torpedo aviation.

The command of the fleets gave great attention to joint operations of aviation and submarines on the enemy sealanes. For example, on 29 March 1943, the Northern Fleet for the first time simultaneously employed four submarines with active support of torpedo and bomber aviation. The essence of their employment was in the extensive reciprocal exchange of information on the detected convoys (through the fleet command post and directly between the cooperating forces) and the launching of successive strikes against them. This was preceded by careful training of the aircraft and ship crews as well as the command and control bodies. In truth, in the first attempts at cooperation between subs and aviation, technical factors prevented the achieving of good results. Thus, the installing of the VAN-PZ radio antennas which made it possible for the submarines to receive at periscope depth started only at the end of 1943. Prior to this the forces were controlled only from the fleet command post. But still the first attempt at employing submarines in operational cooperation with aviation was a success. The tactical skill of the commanders was honed in the course of this. The result of developing such cooperation was the elaboration and practical employment in the northern fleet of a new method of utilizing the submarines called "hanging screens" (Diagram 1). They entered the zone of enemy ship movements upon receiving intelligence data from the aviation concerning the detection of the convoys.

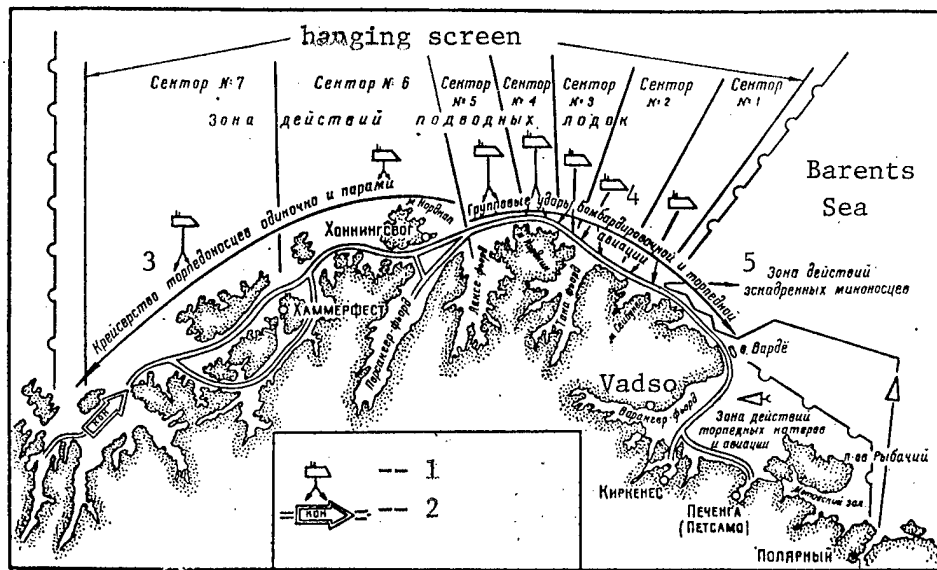

### Joint Actions of Diverse Forces From the Northern Fleet Against Enemy Convoys

- Key:
- 1--Direction of submarine operations
  - 2--Enemy sealanes
  - 3--Cruising of torpedo boats alone and in pairs
  - 4--Group attacks by bomber and torpedo aviation
  - 5--Area of destroyer operations

The torpedo boats and aviation also cooperated successfully on the enemy sealanes. On 26 July 1941, to the west of Ventspils, the air reconnaissance of the Baltic Fleet detected a convoy heading to the Irben Strait. A joint attack was undertaken against it by bomber aviation and torpedo boats.(3) According to the previously elaborated plan for cooperation, the following tactical procedure was employed: the aircraft arrived over the target ahead of the torpedo boats, combining the bomb strike with a diversionary maneuver. This provided a tactical surprise for the torpedo boat operations and the boats also skillfully employed a smoke cloud from an aviation-damaged enemy transport for concealing the start of their attack, closing in unnoticed with the convoy to a maximum short firing range. The escort fighters operated decisively and effectively. They provided a dependable cover for the bombers and torpedo boats and downed two enemy aircraft here.(4)

The Northern Fleet sailors achieved high results in combating enemy convoys during massed torpedo boat strikes supported by aviation. Thus, in combat on 15 July 1944, the enemy lost three transports, a drifter,(5) a tanker, two destroyers and two patrol boats.(6) Success was largely aided by the careful and early preparation for carrying out this combat mission. Preparations lasted more than 2 months during which several practical exercises were conducted with the simultaneous involvement of up to 15-20 boats in each. The boats made massed training attacks, intensely employing smokescreens. In the course of the exercises they carefully developed cooperation between the individual boats as well as the boats with the cover fighters and smokescreen-setting aircraft. The gained experience, in strengthening the reciprocal

understanding between the ship and aircraft crews, as well as their close contact and exchange of opinions in summing up the results of the exercises subsequently served well.

Indicative for this joint attack was the operations against the convoy by submarines along with the aviation and torpedo boats. In planning the operation, the fleet staff assigned a significant role to them as both a strike force and as a means of reconnaissance. The submarines successfully carried out the first mission. Having received preliminary data on the route and composition of the convoy detected by aviation on 11 July in the area of Tromso, they made a sweep in this area. On 15 July, S-56 (commander, Capt 2d Rank G. I. Shchedrin) and M-200 (commander, Capt Lt V. L. Gladkov) came out on the convoy course and attacked it. They sunk a minesweeper and destroyer. They could not carry out the second mission. In escaping from extended enemy pursuit, the submarines were unable to provide updated data on it. This could be done only by signals intelligence. On the same day this equipment again detected the convoy and guided two YaK-7 aircraft toward it and these planes conducted additional reconnaissance in the interests of the torpedo boat detachment. Here the detachment commander, Capt 3d Rank V. N. Alekseyev, personally heard the report of the air group commander and in the course of a conversation with him clarified the situation, the state of the sea and the nature of the shoreline in the area where the convoy was, the route of its movement, the strength of the escort and so forth. The exhaustive replies from the pilot to a significant degree made it easier for the torpedo boat commander to take a correct decision for seeking out and attacking the convoy and assigning missions to the boat commanders.

The massed employment of torpedo boats (with air support) and the launching by them of a simultaneous attack against different targets disorganized the enemy, it scattered the convoy escort forces and weakened the density of its return fire. Individual boats were able comparatively easily to approach within torpedo attack range and make an accurate launch. The closing with the enemy to an attack range and the escape after the attack were also ensured by the skillful use of smoke equipment by the boat commanders.

The employment of torpedo boats against enemy convoys was marked by high results particularly when their cooperation with aviation was not restricted to the use of air reconnaissance data an air cover and sporadic aircraft support. The combining of torpedo attacks with air strikes was more effective.

Characteristic of such actions was the operation of the Northern Fleet conducted from 15 January through 5 February 1944. Participating in it were submarines deployed in a hanging screen along the northern coast of Norway, torpedo boats, destroyers and aviation. Each branch of forces was assigned a definite area of operations (Diagram 1). The result of the operation was the sinking of five enemy transports and two tankers and the damaging of a patrol boat and transport.

At the same time there were also shortcomings. Experience showed the difficulty of organizing joint actions between the submarines, surface vessels and air forces of the fleet and primarily under the conditions of a polar

night and stormy weather. Particularly ineffective under these conditions was the employment of bomber and reconnaissance aviation and the torpedo boats. Because of meteorological factors the planes were grounded for a long time while the poor seaworthiness of the boats did not make it possible for them to set to sea.

The experience of the given operation was employed subsequently. Joint actions became more systematic and intensive due to an increase in the size of the fleet, the greater flexibility of the command and control system and the higher combat skill of the ship and aircraft crews and primarily their commanders.

During the period of the most intense enemy movements, specific strikes were made against the assembly points and destinations of the convoys and these were aimed at destroying them before leaving port or upon arriving there. These were made chiefly by aviation while the other naval forces were employed in carrying out secondary (support) mission such as sealing off enemy ports and coastal airfields, feints by ship groupings and fire and fire cover.

An example would be the launching of an attack against Constanta in August 1944 by aviation from the Black Sea Fleet with supporting actions by surface vessels and submarines (Diagram 2). In truth, in terms of its scale this operation went somewhat beyond combat on the sealanes. But in the total of missions carried out in the course of it, the essential one was the establishing of conditions which impeded the movement of enemy convoys and the actions of enemy ships in escorting the transports and vessels. Simultaneously with the operation against the Constanta Naval Base, combat was planned by diverse naval forces against the enemy ships and transports making various movements along the sealanes along the seacoast and along the Danube as well as strikes against the river ports. Involved in them were the air forces of the Black Sea Fleet and launch formations from the Danube Flotilla. Special measures were worked out to rescue the escorting aircraft crews. Assigned for this purpose were seaplanes, torpedo boats, as well as a portion of the submarines which at that time were operating on the sealanes along the coast of Romania. In an exercise held a week prior to the start of the operation, the questions of cooperation among the different forces were worked out.

After the exercises the table of code signals was corrected for controlling the formations. All the commanders were given the necessary diagrams, graphs and organizational instructions. In the process of preparation, and this lasted around 6 weeks, the fleet commander and the air force commander held the corresponding instructional meetings. Theoretical conferences were also held with the flight and technical personnel, operational-tactical games with the leadership and staff officers, group exercises and so forth. The subject of these was the actions of the naval aviation and the supporting forces against naval bases, ships and transports in them and the maintaining of close cooperation in the course of the operation. Personal visits to the formations, units and subunits by the staff officers were widely practiced.

THE ORGANIZATION OF SUBORDINATION AND COOPERATION AMONG THE DIVERSE NAVAL FORCES  
IN THE COURSE OF THE OPERATION OF THE BLACK SEA FLEET AVIATION IN AUGUST 1944

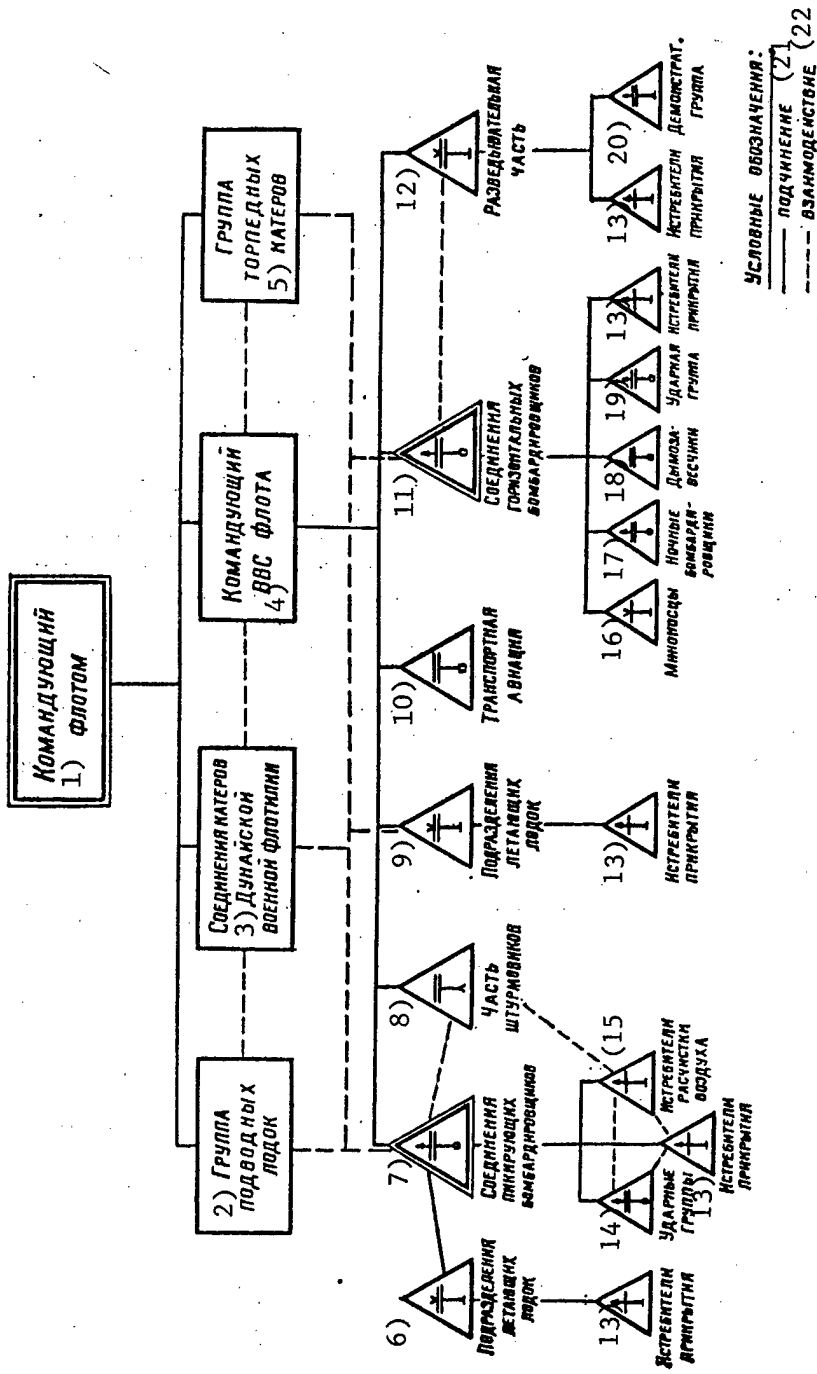

- Key: 1—Fleet commander; 2—Submarine group; 3—Formations of launches from Danube Naval Flotilla; 4—Commander of fleet air forces; 5—Torpedo boat group; 6—Subunits of flying boats; 7—Formations of dive bombers; 8—Unit of ground attack planes; 9—Subunits of flying boats; 10—Transport aviation; 11—Formations of level-flight bombers; 12—Reconnaissance unit; 13—Cover fighters; 14—Strike groups; 15—Air clearing fighters; 16—Mine-laying aircraft; 17—Night bombers; 18—Smoke-laying aircraft; 19—Strike group; 20—Feint group; 21—Subordination; 22—Cooperation.

In line with the change in the situation, individual combat missions envisaged by the operational plan were also changed.

The operation which resulted in the sinking and damaging of a number of fighting ships and auxiliary vessels,(8) was an instructive example of the massed employment of aviation (with the support of other forces) against enemy ships and transports at anchorages, loading and unloading points. This was characterized by correct planning, by careful thorough preparations and by the dependable operational and tactical cooperation of the diverse forces. The skillfully organized command of the forces made it possible to quickly evaluate the situation and promptly adjust the actions of the strike and support groups. Also effective was the planning of measures to rescue aircraft crews which, aside from practical benefit, also had a psychological effect.

The basic task in attacking the assembly points and destinations of the convoys was to destroy transports and fighting ships (the port installations, as a rule, were alternate targets). Before the mission was carried out these points were sometimes fired on, if distance permitted, by the shore artillery and this also ensured results from the air operations. After an air strike, artillery continued to fire in the aim of preventing the extinguishing of fires and the carrying out of emergency reconstruction. Similar cooperation occurred, for example, in the launching of attacks against the ports of Pechenga and Linahamari by the Northern Fleet aviation (1944). The coordinated actions of the aircraft and shore batteries were monitored by the fleet staff. The measures undertaken by it included: combining the attacks for the greatest effectiveness of the artillery and air operations; determining the primary targets; providing the shore batteries and air subunits with precise target designations and final intelligence data on the enemy.

Active minelaying on the enemy sealanes played an important role in increasing the effectiveness of fleet operations in interdicting or impeding enemy sea movements. This was confirmed by the experience of the very first weeks of the war. In time the importance of mine weapons in interdicting sea movements increased even more. Thus, the 66 active minelayings carried out by the Northern Fleet patrol boats covered by aviation in Varangerfjord in 1943 seriously impeded enemy transport movement in this area. Aviation, submarines and surface vessels were involved in active minelaying (depending upon the weather conditions, time of day, the nature of one or another sealane and the system of its defense as well as the scale and aims of the minelaying). Here the essence of cooperation was: to provide safety for the main forces (in carrying out the mission) against enemy action; in preventing enemy attempts to establish the precise place where the mines were to be laid and if this did happen, to prevent the thwarting of their laying. Cooperation procedures, along with other questions, were determined by the battle order of the fleet commander. It set a detailed mission for the support group (aircraft, surface vessels, submarines and shore artillery) as well as for the cover group. Also considered were preliminary measures which encompassed the training of the personnel (aircraft and ship) as well as the techniques for receiving, preparing and setting the mines and the elaboration of the appropriate documents. For example, in the Baltic Fleet each time the minelaying detachment(9) set to sea, the command of the torpedo boat brigade worked out a

battle order, an additional combat manual, a communications plan, a planning table and a calculation of the mine defense as well as the procedure for receiving and utilizing intelligence data from the fleet aviation and for combat cooperation with it in the course of minelaying. The fleet staff organized the cover and support. In accord with the instructions of the fleet commander, fighters, as a rule, patrolled over the mine receiving point. During the move of the detachment, they provided support making periodic flights along the course of the boats. Prior to their run a careful air reconnaissance was made of the travel area and the minelaying zone as well as the nearest enemy bases and airfields. If possibilities permitted, bombers were assigned and kept ready in the event of an attack by enemy ships on the minelaying detachment and the shore artillery batteries and ship cover group were brought to a combat alert. As a result of the careful preparations and due to the clearly organized cooperation of the diverse forces, minelaying was usually carried out successfully and without enemy resistance. This was also achieved by employing poor visibility and by carrying out diversionary feints by individual ships and planes or by small air and ship groups.

In the course of the war, active mine defenses on the near enemy sealanes in the Gulf of Finland (Baltic Fleet), Kerch Strait (Black Sea Fleet) and the Varangerfjord (Northern Fleet) were set out, as a rule, by torpedo and patrol boats. The use of mine weapons by submarines was extremely limited and most often, without being of independent significance, was combined with their combat runs against convoys. Aviation set mines on the approaches to ports, on coastal channels and in narrows, often combining this mission with others which were primary for it.

Thus, the missions of disrupting the enemy sealanes in all the maritime theaters were carried out by aviation, submarines and partially by surface forces (chiefly torpedo boats). In certain coastal areas, shore artillery was also involved in carrying out this mission.<sup>(10)</sup> The results of the actions by the diverse Navy forces on the enemy sealanes during the years of the Great Patriotic War provide grounds to feel that aviation played the most predominant role in them. Second place belonged to submarines. Surface vessels played a very minor role in fighting enemy shipping. But the main conclusion in analyzing the operations on enemy sealanes in the years of the last war would be the following: single strikes made by uniform forces did not make it possible to count on the complete destruction of one or another convoy. For this reason the command of the Navy and the fleets was constantly searching for the most effective methods of organizing close cooperation among the different branches of arms in attacking the enemy at sea.

Mine weapons played a significant role in damaging the enemy convoys. This was explained by the fact that the enemy sealanes were predominantly of a coastal nature. Regardless of the limited number of mines set by our fleets, enemy transport losses from them were higher than from the surface ships and shore artillery, taken together.

Daily (systematic) combat operations were the main form of employing the naval forces on the enemy sealanes. In truth, the fleets also conducted operations in the course of combat on the sealanes.

#### FOOTNOTES

1. V. I. Achkasov, N. B. Pavlovich, "Sovetskoye voyenno-morskoye iskusstvo v Velikoy Otechestvennoy voyne" [Soviet Naval Art in the Great Patriotic War], Moscow, Voenizdat, 1973, p 388.
2. For operations to disrupt enemy sealanes in 1941-1942, mainly submarines were employed; aviation, surface vessels and coastal artillery operated sporadically.
3. TsVMA [Central Naval Archives], folio 27, file 260, sheets 80, 81; folio 46, file 25882, sheet 98; folio 122, file 10306, sheet 25.
4. P. V. Kolesnik, N. F. Noga, "Sbornik takticheskikh primerov deystviy sil VMF po opytu Velikoy Otechestvennoy voyny 1941-1945 gg." [Collection of Tactical Examples of Naval Operations in the Experience of the Great Patriotic War of 1941-1945], Leningrad, Izd. VVMU imeni M. V. Frunze, 1982, pp 201-204.
5. A fishing vessel equipped with special nets.
6. MORSKOY SBORNIK, No 11-12, 1944, p 30.
7. [not in text]
8. Sunk were: a submarine, a destroyer, eight landing vessels, eight patrol and torpedo boats and a tanker. Damaged were: five submarines, two destroyers, an auxiliary cruiser, a gunboat and two transports. Significant damage was caused to the port facilities. Our losses were: three bombers and one fighter and the bomber crews were rescued. See: A. M. Gakkel, A. N. Zamchalov, K. V. Penzin, "Istoriya voyenno-morskogo iskusstva" [History of Naval Art], Leningrad, Izd. Voenno-morskoy akademii, 1980, p 72.
9. It was especially established by the staff of the torpedo boat brigade consisting of two groups.
10. The shore batteries of the Northern Fleet located on Sredniy Peninsula by their fire prevented the movement of enemy ships and transports on the the approaches to Petsamo and this forced it most to abandon the use of this port.

COPYRIGHT: "Voyenno-istoricheskiy zhurnal", 1985

10272

CSO: 1801/272



## ORGANIZING 'OPERATIONAL REAR' DURING WORLD WAR II

Moscow VOYENNO-ISTORICHESKIY ZHURNAL in Russian No 6, Jun 85 (signed to press 28 May 85) pp 26-32

[Article by Doctor of Military Sciences, Prof, Maj Gen N. A. Malyugin: "Improving the Operational Rear"]

[Text] As is known, in the course of the Great Patriotic War the rate of advance of the troops and the depth of operations continued to grow constantly while the effective strength of the fronts and the armies increased. As a result the need for materiel rose significantly and the maneuvering of these in the course of combat assumed great importance. All of this necessitated an improvement in the rear of the operational field forces as the main element of the rear of an operational army. This was carried out in many areas. The given article examines only certain of them.

Logistic support and transport. The material requirements of the troops in operations, the amount of supplies to be stockpiled in the fronts and armies as well as the procedure for moving them were determined in prewar years by the storage conditions and by the transport capability of the means of transport (Table 1).(1)

Proceeding from the length of one front-level operation of 20-30 days and its depth to 250 km, a 10-day supply was established in the army rear zone closest to the troop rear area and a 10-day reserve on the proposed boundary of the army and front rear areas.

The number of logistic support units and facilities in the armies and on the fronts was not constant but was set depending upon the effective strength, the missions to be carried out and the range of work. All the army and front dumps were of the stationary and semi-stationary type and considering their large number it was extremely difficult to control them in a rapidly changing situation. For example, in August 1941, the Southwestern Front along with the armies had more than 100 different dumps and the Western Front had over 80. The army rear was equally cumbersome as certain armies each had up to 25 dumps and a large number of other rear units and facilities.

Table 1

**Amount of Material Supplies in Troop and Operational Rear  
According to Prewar Views**

Types of supplies, their echeloning and destination	Materiel		
	Ammunition, units of fire	Fuel, fuelings	Food, daily rations
Mobile (in troops)			
--in rifle (cavalry) division	1.5	3.0	5
--in tank (motorized) division	2.0	2.5	5
Day-to-day			
--at army dumps:			
a) on offensive	0.75-1.5	to 2.0	to 2-5
b) on defensive	0.75-1.0	to 1.0	3-4
--at front dumps	8-10	to 10	to 30

Table 2

**Change in the Depth of Rear Areas in the Course of the War**

No.	Periods	Depth of rear area, km			
		of a front	of an army	of a formation*	Total
1	According to prewar views	to 500	75-175	50-75	650-750
2	During war years (draft regulations on front and army rear)	150-200	75-100	20	200-370
3	During war years (from experience of major operations):				
	a) on the defensive	180-250	100-150	30	310-400
	b) on offensive:				
	--in preparing operations	150-250	50-100	15-20	215-370
	--in course of operations	200-300	150-200	--	350-500

\*Along with regimental rear area (8-12 km).

As a result, even during the first months of the war substantial shortcomings were disclosed in troop logistic support. This caused the Soviet Command in the course of combat to begin a reorganization in the accepted logistic support system. Along with establishing the rear of the Center in the Red Army Main Directorate of the Rear, by an order of the NKO [People's Commissariat of Defense] of 1 August 1941, they also began organizing operational rear bodies. On the fronts and in the armies they introduced rear directorates or headquarters headed by a chief of the rear who was also a deputy commander of the front (army). Precisely in this period they also began establishing, in essence, the field supply depots of the Center, the fronts and the armies.

On 1 August 1941, front regulating stations (FRS) were established in the fronts and these played an important role in improving troop supply, in transporting materiel and organizing accounting. The stationary dumps were the basis of the FRS. The necessary resources were made available to the chiefs of the stations for carrying out cargo handling work, for security and defense of the FRS. The materiel delivered to the FRS was accounted for as the available property of the front.

For improving the work of the operational rear and for increasing its mobility and maneuverability, by an order of the NKO of 2 September 1941, in the area of the FRS they also established front field dumps (FPS) for artillery, armored-tank, quartermaster and military-technical supplies and fuels and lubricants while in the armies there were the field army depots (PAB) consisting of eight field dumps (that is, the same five dumps as on a front plus other additional dumps for the air forces, medical and veterinary supplies). The amount of supplies at the field dumps and distributing stations of the fronts was determined by the General Staff and at the dumps of the PAB by the front military council.

In December 1941, under a decision of the GKO [State Defense Committee] NKO distributing depots were established for all types of materiel as well as central distributing stations (TsRS). The NKO and TsRS depots were placed under the chief of the Soviet Army Rear and were designed to receive and stockpile supplies, to organize the transporting of materiel to the fronts and armies operating on independent axes as well as for providing help to the fronts in evacuating sick and wounded, unnecessary supplies and captured equipment to the deep rear.

In order to reduce the need for transport to be assigned for transporting and maintaining the front and army dumps, in October 1941, new significantly reduced stock maintenance standards were established with particular reductions in the fronts. Thus, at the front depots the new orders provided the storage of up to one scale of fire of ammunition (instead of eight-ten), two fuel loads (instead of ten) and 15 days of food (instead of 30) and at the army dumps 0.75 units of fire of ammunition (instead of 1-1.5) and one load of fuel (instead of one-two).(2)

The high consumption of all types of supplies by the troops demanded the more economic and thrifty employment of the materiel. For this reason by orders of the NKO (September-October 1941) limits were introduced on the issuing and

consumption of ammunition and fuel. The central supply bodies set limits for the fronts while the front commanders did the same for the armies and the army commanders for the formations. The limiting of the consumption of material resources made it possible to establish a uniform and firm basis for planned supply in all the rear elements and this was an important means for monitoring the use of materiel. In accord with the new requirements the system was revised for accounting and reporting, acceptance and issuing as well as the safekeeping of freight enroute and the procedure for responsibility for this in transporting and delivery to recipients.

Due to the successes of the Soviet economy in the summer of 1942, real conditions were established for increasing the supplies of materiel at the front and army dumps. However, no rigid standards for the supplies to be stored were set. In each specific instance their quantity depended upon the situational conditions. In truth, sometimes a minimum supply of the basic types of materials was established at the army and front dumps. Subsequently, with the going over of the Soviet Army to an offensive, particularly after the Battle of Stalingrad, the consumption of materiel began to constantly rise and this necessitated an increase in their stocks in the troops as well as at the army and front dumps.

With the start of the war the difficult problem arose of delivering the materiel, particularly in the troop and operational element, where the shipments were basically made by motor transport. By the GKO Decree of 15 July 1941, motor vehicle-road headquarters were established in the fronts and in the armies there were sections under the chief of the all-arms staff. With the formation of independent rear bodies at the center and in the field, the motor vehicle-road headquarters (sections) were put under the front and army chief of the rear. However, the established bodies could not fully carry out the tasks entrusted to them and in May 1942, they were reorganized into the headquarters (section) for motor transport and road service of the front (army). In the aim of combining the leadership of motor transport, its operation and technical maintenance for automotive equipment and supplies, by the NKO Order of 15 January 1943, the Main Motor Vehicle Directorate of the Red Army (GAVTU) was established. Objectively such an organization gave rise to duality in the leadership of motor transport as the motor transport units were part of the system of the Soviet Army Rear and were under the Main Motor Vehicle-Road Directorate while the questions of their manning, supply, repair and maintenance were carried out by the GAVTU the bodies of which were not under the chief of the rear. For this reason, by the GKO Decree of 9 June and the NKO Order of 12 June 1943, the Main Directorate for Motor Transport and Road Service at the center, the headquarters (sections) in the fronts (armies) were changed into the Main Road Directorate of the Soviet Army and into road directorates (sections) of the fronts (armies). The motor transport formations and units, the repair enterprises, motor vehicle supplies and the bodies engaged in planning and managing motor vehicle movements of troops and freight were turned over to the Motor Vehicle Service from the Motor Vehicle-Armored Directorate.(3)

The actual transporting of materiel continued to be improved. The documents relating to the command of the rear initially did not establish responsibility of the specific leaders for the prompt delivery of freight and troops. The

commanders of the motor transport units and subunits and the chiefs of the transport trains were responsible for their safekeeping enroute. The army chief of a motor road was responsible for fulfilling the transport and evacuation plan only on his road. In the army and on the front there actually was no official who was responsible for the delivery of materiel and the use of the motor transport. This gave rise to indifference and irresponsibility among the rear command bodies for the organization and execution of transport. Moreover at that period the troops were considered responsible for all materiel which had been turned over to the transport subunits of subordinate troops regardless of whether the freight had been delivered to the dumps or not. This led to a situation where the rear bodies and superior staffs did not always know the real supply situation of the divisions and regiments.

The experience of the transporting of materiel to the troops indicated that the then adopted principle of transporting "for oneself" had a number of essential shortcomings. With such a transport procedure the divisional transport was to receive materiel from the army dumps and deliver this to the regiments. However, due to the great distance between the troops and the repaired railroad sections where the army dumps were located, the transport of the formations often could not handle this job. As a result, it often developed that the army dumps had a sufficient amount of supplies while the troops were in acute need of them.

The special GKO Commission, in checking the work of the rear of the Kalinin Front in the spring of 1943, examined the organization of the delivery of materiel to the troops and concluded the need for the centralized and efficient use of the means of transport as well as designating a specific official responsible to the commander for the transporting of all types of materiel. On the basis of the commission's conclusions, the GKO adopted a decision to alter the transport system in the Soviet Army. By the NKO Order of 12 June 1943, responsibility for the delivery of materiel to subordinate troops, regardless of the affiliation of the transport employed, was entrusted to the senior chief of the rear. Thus, the chief of the army rear was responsible for the delivery of freight to the divisional exchange points and the chief of the divisional rear to the regimental dumps. Here in the supply situation they took into account only that materiel which had been delivered to the dumps of the subordinate troops.

Along with improving the motor transport control system and changing the principle of delivering the materiel, by mid-1943, real opportunities had been established for increasing the amount of motor transport on the fronts and in the armies. While in 1942-1943, the fronts had an average of three-six separate motor transport battalions for delivering materiel and an army had one or two, in 1944-1945, each front had, as a rule, a three-regiment motor vehicle brigade and an army had two or three separate motor vehicle battalions.

The increased motor transport in the troops was of important significance for maintaining the stability of the entire rear supply system with the increased needs of the troops for material and technical means.

Disposition and movement of the rear. In determining the depth of the rear

areas of fronts and armies as well as in locating the dumps and other stationary rear facilities in the prewar years it was felt that they should be spread out in depth in order to reduce the effectiveness of enemy air actions. For this reason the depth of the rear areas in the fronts was 400-500 km and in the armies (along with the troop area) some 125-250 km. The total depth of the troop and operational rear could reach 700 km and more (Table 2). However, the practice of the very first operations showed that with such a depth of the rear areas and the great distance of the rear from the combat units, uninterrupted troop supply was not ensured. For this reason in the operational rear there was a tendency to reduce the depth of the rear areas and bring the men and weapons of the rear closer to the troops. As a result, the rear units and facilities gained an opportunity to work longer in one place and not waste time in frequent moves. Moreover, the delivery and evacuation distance was shortened and, consequently, the need for transport. The amount of work on road support was reduced, fewer resources were needed for covering the lines of communications and for security of the rear, and communications was improved with the rear units and facilities. All of this helped to establish a stabler system of rear support for the armies and the front.

Even during the period of the defensive battle at Moscow, a larger portion of the front and army rear units and facilities was located a short distance from the troops: a distance of 70-190 km for the front ones and 20-40 km for the army ones. This made it possible to supply the armies, corps and divisions directly from the front and army dumps but created many difficulties in the event of the forced retreat of the troops. In the Battle of Stalingrad, the depth of the rear areas was: 220-250 km on the Southwestern Front, 210-250 km on the Don Front and up to 400 km on the Stalingrad Front.(4)

The trend toward bringing the rear units closer to the troops was maintained in subsequent operations. By the war's end the depth of the rear areas, in comparison with the prewar views, had been reduced by more than double (Table 2).

The commanders of the field forces and their deputies for the rear paid more attention to increasing the survivability of the rear by the following measures: the rear units were positioned in a dispersed manner, rigid camouflage measures were instituted, the rear positions were organized in engineer terms and were securely covered against the air and ground enemy.

During the very first days of the war, the question of securing and defending the operational rear arose sharply. For this reason by the Decree of the USSR SNK [Council of People's Commissars] of 26 June 1941, rear security bodies were established. Usually senior chiefs from the NKVD [People's Commissariat of Internal Affairs] Troops were appointed to the position of chiefs of rear security. A checkpoint service was organized on motor roads and on railroads, stage-checkpoint commandant staffs were established.

Control and command of the rear. In line with the need to ensure the centralization of command and control, the organizational structure of the rear command bodies was improved. The establishing in August 1941 of independent rear bodies at the Center on the fronts and in the armies was, as

is known, an important step in improving the organization of troop rear support. The all-arms staffs were freed of the functions not inherent to them of organizing supply and gained the opportunity of focusing full attention on troop leadership.

By the NKO Order of 25 May 1942, the position of deputy chief of the rear was introduced on the fronts and rear staffs were established in the place of the organizational-planning sections at the rear headquarters of the fronts and armies.(5)

The supply command bodies were also improved. By a GKO decree, the food service in January 1942 was made into an independent service, the Food Supply Directorate was reorganized as a main directorate while the food sections of the fronts became headquarters with their subordination to the chief of the front's rear.

After the liberation of the occupied areas of the country from the Nazi invaders and the shifting of combat to the territory of the Eastern European countries, new tasks arose for the operational rear. The procurement bodies of the fronts and armies were reinforced for directing procurement of food and fodder and utilizing other materiel on the territory of foreign countries. On a number of fronts, agricultural headquarters were established and their mission included assisting the local bodies in carrying out planting and harvesting work as well as procuring and purchasing agricultural products for the needs of the operational army.

In the summer of 1944, with the start of using the Western European gauge railroads for transporting, transloading depots began to be established at their junctions with the Soviet railroads (along with widening certain sections to the Soviet gauge). The first transloading depot was organized at the connection of the Soviet railroad with the Romanian at Veresty Station in the rear area of the Second Ukrainian Front. Subsequently as the Soviet troops advanced to the west, another 11 bases were organized (basically of central subordination). At the areas of the transloading depots, medical collection areas were set up for receiving sick and wounded to be evacuated into the deep rear of the nation. In line with the need of operating the railroads on foreign territory, in the VOSO [military transport] headquarters of certain fronts, sections for shipments over the Western European gauge were set up and they established commandant offices for the railroad sections and stations, stage-checkpoint commandant staffs and military food points.

Naturally, before the war the Soviet Army did not have a captured equipment service. Only after the fundamental reorganization of the rear services in August 1941 was the first attempt made to set up such bodies. At the Center the evacuation section of the rear staff became this and on the fronts and in the armies there were evacuation sections (departments) of the rear headquarters. In line with the increased amount of work involved in collecting captured property, weapons and scrap metal as well as their accounting and storage, in March 1942, by a GKO decree, within the Main Directorate of the Soviet Army Rear they established a Directorate for the Collection and Use of Captured Weapons, Property and Scrap Metal while on the fronts and all-arms armies there were analogous sections.

Somewhat later, in 1943, the Directorate for the Collection and Use of Captured Weapons, Property and Scrap Metal was reorganized at the Main Captured Property Directorate and was put under the newly established Captured Property Committee of the GKO headed by MSU K. Ye. Voroshilov. The front captured property sections were reorganized as headquarters and shifted to the Main Captured Property Directorate and in operational terms to the command of the fronts.

In the course of the successful offensive operations of 1944-1945, the Soviet troops captured a large amount of enemy equipment. The new tasks caused a further strengthening of the bodies of the captured equipment service. In order to more fully utilize captured food and clothing in the front (army) captured equipment headquarters (sections), in April 1944 quartermaster captured equipment sections (departments) were organized. By the NKO Order of 19 February 1945, the chief of the captured equipment headquarters (section) was to become the deputy chief of rear of the front (army).

In order to eliminate parallelism in the work of the captured equipment service, the Captured Equipment Committee Under the GKO in February 1945 was abolished and the Main Trophy Directorate was put directly under the chief of the Soviet Army Rear.

The experience of the rear gained in the operations of the first period of the war showed that it was essential to make changes in the theoretical provisions concerning the work of the operational rear and to bring these into accord with the existing situation and the prospects of its development. In March 1942, the draft provisions on the organization and work of the army rear were worked out and in January 1943, the draft provisions on organizing the work of the front rear.(6)

On the basis of the experience gained in the course of the war, fundamentally new headquarters bodies for the operational rear were established and their leadership was centralized in the hands of a single official, the chief of the rear and deputy commander of the front (army) for the rear.

#### FOOTNOTES

1. TsAMO SSSR [Central Archives of the USSR Ministry of Defense], folio 13, inv. 137146, file 5, sheets 9-19.
2. "Tyl Sovetskikh Vooruzhennykh Sil v Velikoy Otechestvennoy voyne 1941-1945" [The Rear of the Soviet Armed Forces in the Great Patriotic War of 1941-1945], Moscow, Voenizdat, 1977, p 83.
3. Ibid., pp 269, 270.
4. Ibid., p 108.
5. TsAMO, folio 67, inv. 12022, file 84, sheet 81.



6. "Sbornik materialov po izucheyu opyta voyny" [Collection of Materials on Studying the War's Experience], Moscow, Voenizdat, No 2, 1942, pp 160-171; No 4, 1943, pp 132-143.

COPYRIGHT: "Voyenno-istoricheskiy zhurnal", 1985

10272

CSO: 1801/272

DOCUMENTS ON 'LIBERATION' OF NORTHEAST AREAS

Moscow VOYENNO-ISTORICHESKIY ZHURNAL in Russian No 6, Jun 85 (signed to press 28 May 85) pp 33-36

[Documents prepared by Col I. V. Yaroshenko and L. I. Smirnova under the rubric "Documents and Materials": "The Liberation of the Soviet Arctic"]

[Text] The Great Patriotic War provided rich experience in conducting battles and operations under difficult physico-geographic and severe climatic conditions of the Arctic. The final attack against the Nazi troops was launched there in October 1944 in the course of the Petsamo-Kirkenes Operation by troops of the 14th Army of the Karelian Front and by forces of the Northern Fleet.

The command and staff of the front began preparing for the offensive on the Petsamo-Kirkenes sector during the period of completing the Svir-Petrozavodsk Operation. On the basis of the directive from Hq SHC, the Karelian Front Command at the end of September 1944 completed the elaboration of the plan for the offensive operation (Document 1) and submitted it for approval to the Supreme Commander-in-Chief. After its approval, on the same day the troops received an operational directive for conducting the Petsamo-Kirkenes Operation (Document 2).

Document 1

FROM THE REPORT ON THE PLAN FOR THE OFFENSIVE OPERATION  
BY THE KARELIAN FRONT TO LIBERATE THE PETSAMO REGION

I am reporting a plan for conducting an offensive operation by forces of the 14th Army on the Murmansk sector in accord with the directive of Headquarters of 26 September 1944.

1. The situation

On the Murmansk sector, in covering the approaches to Petsamo, Luostari and the area of the nickel mines, the troops on the defensive are the XIX Mountain Corps Norway consisting of the 2d and 6th Mountain Chasseur Divisions, units from the 210th Infantry Division, the 388th Separate Chasseur Brigade and the 503d Separate Airfield Brigade. The XIX Mountain Corps Norway on the Murmansk

sector has been on the defensive for 3 years and has a strongly fortified defensive area.... As a total in front of the 14th Army one can expect four or five infantry divisions and two separate infantry brigades.

2. The overall plan for the offensive operation of the 14th Army is to clear the Nazis out of the Petsamo area.

3. Overall plan for the operation

The main thrust by the group of forces consisting of three rifle corps and two light rifle corps will be made by the army on the general axis of Luostari, Petsamo with the mission of crushing the Nazi 2d Mountain Division by a frontal thrust combined with an outflanking maneuver of the light corps, to capture the area of Luostari, Petsamo and, having covered oneself on the Salmiyarvi Axis, to destroy the encountered enemy forces in the Titovka area and further to the southeast.

The immediate task of the army is to break through the enemy defensive front on the sector from Lake Chapr, elev. 237.1, to cross the Titovka River (Valas-Yoki River) and, with the simultaneous outflanking of the right flank of the 2d Mountain Division by the CXXVI Light Rifle Corps, to crush the enemy 2d Mountain Division and come out on a front of elev. 168.8, elev. 179.0, Lake Khiri-Yarvi, Lake Kheynya-Yarvi, Kyaloyvi area, Lake Tul-Yaur and the town of Mattert.

The subsequent mission is to capture the area of Luostari, Petsamo and close off the route of escape for the enemy units fighting in the area of Titovka and to the southwest, reaching a line of Lake Rogi-Yarvi, the waterfall, Lake Kuavla-Yarvi, Provara, Trifona, Lake N yasyukya-Yarvi, Lake Lyuppe-Yarvi, the town of Palovara, Lake Pilgu-Yarvi, Lake Kallo-Yaur.

Subsequently, in covering oneself on the Salmiyarvi axis, to defeat the troops remaining in the Titovka area and to the southeast. Upon carrying out the designated missions the army is to prepare for advancing to the south in the aim of reaching the state frontier.

4. The grouping of the 14th Army forces

For carrying out the set mission the 14th Army is to deploy its forces in two operational echelons.

The first echelon on the axis of the main thrust is to be deployed on a front of Lake Chapr, elev. 237.1 of the following composition: two rifle corps, five rifle divisions (the XC and CXXXI Rifle Corps consisting of the 10th Guards, the 65th, the 368th, the 14th and 114th Rifle Divisions), the CXXVI Light Rifle Corps (the 31st and 72d Light Rifle Brigades), one tank brigade (the 7th Guards Tank Brigade), two tank regiments and reinforcement artillery.

The second echelon is the XXXI Rifle Corps consisting of the 45th and 83d Rifle Divisions and is to be concentrated in the area of Lake Kuyrk-Yarv, the rapids, elev. 309.9, Lake Port-Lubol and the CXXVII Light Rifle Corps

consisting of the 69th and 70th Rifle Brigades is to be concentrated in the area of elev. 276.2, Lake Seyb-Yavr, Lake Vyshniy-Yavr, Lake Mokki-Yavr....

The 367th Rifle Division from the XXXI Rifle Corps, the 3d Rifle Brigade and the 2d Fortified Active Defense Area on the sector of Bolshaya Zapadnaya Litsa Guba, Lake Chapr, is to support the right flank of the army.

#### 5. Planning of operation

The army operation is to be carried out in three stages.

The first stage is the breaking through of the enemy defenses, the crossing of the Titovka River (the Valas-Yoki River) and reaching a line of elev. 168.8, elev. 179.0, Lake Khiri-Yarvi, Lake Kheynya-Yarvi, Kyaloyavi area, Lake Tul-Yaur and the town of Mattert. The depth is 16 km. The length of the stage is 3-5 days.

Second stage is to capture the area of Luostari, Petsamo and reach the line of Rogi-Yarvi, the waterfall, Lake Kuavla-Yarvi, Porovara, Trifona, Lake Nyasyukya-Yarvi, Lake Uyuppe-Yarvi, the town of Palovara, Lake Pilgu-Yarvi, Lake Kallo-Yaur. The depth is 20 km. Length of the stage is 3-5 days.

The third stage is to fully clear the enemy from the area of Titovka and reach a line of the state frontier on the section Vuoremi, Salmiyarvi. The depth is 25-30 km. Length of the stage 4-5 days.

The depth of the operation is 50-60 km. Length 10-15 days.

#### 6. Effective strength

Reinforced by the resources of the front, the 14th Army will consist of: three rifle corps (XXXI, XCIX and CXXXI) with eight rifle divisions (10th Guards, 14th, 65th, 114th, 368th, 45th, 83d and 367th Rifle Divisions), two light corps (CXXVI and CXXVII) consisting of five rifle brigades (3d, 31st, 69th, 70th and 72d), nine artillery regiments, nine mortar regiments, two M-31 rocket-launching brigades; three M-13 rocket regiments, two heavy self-propelled artillery regiments, two engineer brigades (the Svirsk 20th Shock Motorized Combat Engineer Brigade and the 1st Motorized Special-Purpose Engineer Brigade), one tank brigade and two tank regiments.

Total guns: 50 152-mm howitzer cannons, 48 150-mm German howitzers, 47 122-mm cannons, 123 122-mm howitzers, 215 76-mm long-range artillery, 132 76-mm field artillery, 433 45-mm, 48 76-mm mountain guns; mortars: 380 120-mm, 72 107-mm, 667 82-mm; aircraft: 357 fighters, 203 ground attack planes, 129 bombers; tanks: 21 KV, 59 T-34, 3 MK-3 (Valentine) and 24 self-propelled mounts (ISU-152).

7. Due to the fact that the concentration of additional forces reinforcing the 14th Army in accord with the Headquarters directive of 26 September 1944, No 220226, can be completed only by 5 October 1944, the troops are to be ready as of 3 October 1944.

8. The above-provided plan for the offensive operation to clear the enemy out of the Petsamo area is submitted for your approval.

Commander of Karelian Front,  
Army Gen Meretskov

Military Council Member of Front,  
Lt Gen Shtykov

Front Chief of Staff,  
Lt Gen Krutikov

TsAMO SSSR [Central Archives of the USSR Ministry of Defense], folio 214, inv. 1443, file 179, sheets 18-23.

Document 2

FROM THE DIRECTIVE OF THE COMMANDER OF THE KARELIAN FRONT  
OF 29 SEPTEMBER 1944 FOR CARRYING OUT AN OFFENSIVE OPERATION

To the commander of the 14th Army

I. On the Murmansk sector, in covering the approaches to Petsamo, Luostari and the area of the nickel mines, on the defensive is the enemy XIX Mountain Corps Norway. In September the enemy, in the aim of securing the withdrawal of its main forces of the 20th Lapland Army into Northern Norway, has regrouped the men and weapons of the XIX Mountain Corps, having strengthened the sector toward Luostari....

Not excluded is the possibility that among the enemy operational reserves in the Petsamo, Luostari area could be a portion of the men and weapons from the southern corps of the 20th Lapland Army which has retreated into Norway.

II. I order:

1. The 14th Army to clear the enemy out of the Petsamo area. The main thrust is to be launched from the area of Lake Chapr, elev. 237.1, Lake Mare-Yavr on the general axis of Luostari, Petsamo with the mission of crushing the enemy 2d Mountain Division by a frontal thrust combined with the outflanking maneuver of a light corps, to capture the Luostari, Petsamo area and, covering oneself on the Salmiyarvi axis, to destroy the enemy forces located in the Titovka area and to the southeast.

Immediate mission: break through the front of enemy defenses on the sector or Lake Capr, marker 237.1, to cross the Titovka River (Valas-Yoki River) and, simultaneously outflanking the right flank of the 2d Mountain Division by the CXXVI Rifle Corps, to crush the Nazi 2d Mountain Division and reach the line of Lake Chapr, Lake Kuosme-Yarvi, Lake Khiri-Yarvi, Lake Kheynya-Yarvi, the town of Silgya-Tunturi, the Petsamo-Yoki River.

Subsequently, the main efforts are to be directed from the Luostari area to rapidly capturing Petsamo and reaching the line of Lake Khiri-Yarvi, Petsamo, Lake Nyasyukky-Yarvi, Lake Lyuppe-Yarvi, Lake Pilgu-Yarvi, Lake Kallo-Yaur.

Subsequently, the plan is to capture as quickly as possible the line of the Iso-Tunturi Range, Porovara, Trifona and, securely covering oneself on the line of Lake Nyasyukya-Yarvi, Lake Lyuppe-Yarvi, Lake Pilgu-Yarvi, Lake Kallo-Yaur, to crush the troops remaining in the Titovka area and to the southeast. On carrying out the designated missions, to be ready to advance to the south in the aim of reaching the state frontier.

2. In the event of an enemy surprise retreat, one must immediately go over to pursuing it with the available army forces, in this instance acting to prevent the main forces of the XIX Mountain Corps in the Petsamo area and further toward the frontiers of Northern Norway to link up with the main forces of the 20th Lapland Army.

3. The army's operational configuration is in two echelons.

The first echelon is to have two rifle corps consisting of five rifle divisions, a light corps, two tank regiments, one tank brigade and reinforcement artillery.

The second echelon will have one rifle corps and one light corps consisting of two rifle divisions and two rifle brigades.

Not more than one rifle division, one rifle brigade and one fortified area are to be assigned for defending the area of Bolshaya Zapadnaya Litsa Guba.

4. It is to be understood that the light corps in the course of developing the operation are to be used on the enveloping flank of the army in the aim of facilitating the development of the frontal breakthrough by the outflanking maneuvers of the light corps in the enemy flank and rear defending on the Luostari sector.

The army second echelon is to be employed depending upon the situation or on the Salmiyarvi axis in the event of the appearance of major enemy forces from the south and from the Kirkenes sector, supporting the left flank of the army, or for defeating enemy forces located in the Titovka area.

III. To the right, the Northern Fleet and the Northern Defensive Area in their previous lines and bases.

With the forces of not less than one rifle brigade, from Sredniy Peninsula, the Northern Fleet is to attack the enemy from the Kutovaya area from the south with the mission of preventing a regrouping of the 503d Airfield Brigade.

On the left the 19th Army is to pursue the retreating units of the enemy XXXVI Army Corps in the direction of Kuoloyarvi.

The demarcation line with it is as before.

IV. Artillery and mortars. The main mission of the artillery is to neutralize the artillery-mortar grouping and crush the enemy defense on the Luostari sector, having supported the army advancing units in breaking through

the enemy defenses, crossing the Titovka River and reaching the area of Luostari, Petsamo.

Artillery softening up of 2 hours and 35 minutes. The procedure for artillery softening up is as follows: a 5-minute intense shelling against the enemy defenses, the artillery and mortar batteries, the staffs, the enemy communications centers and reserves; a 30-minute control of ranging for the registration points and targets and final reconnaissance of the enemy; 60-minute period of methodical destruction of defensive works and partial neutralization of targets and trenches deep in the defenses, a strike against the enemy artillery and mortars; a 30-minute period of air and artillery-mortar neutralization of targets on the forward edge and in the enemy tactical defensive depth; a 30-minute period of artillery-mortar neutralization of enemy defenses and rocket salvos.... The infantry attack is to be accompanied by the method of successive concentration of fire and the infantry and tanks are to be supported in rapidly capturing the strongpoints on the forward edge and the immediate tactical depth.

On the main sector an artillery-mortar density is to be established of at least 150 barrels (not counting the 45-mm guns) per kilometer of front....

Aviation. The operation of the 14th Army is to be supported by the 7th Air Army of the front consisting of three mixed air divisions, two bomber divisions and one fighter division.

The chief mission for aviation is, in close cooperation with the artillery, to crush the defensive enemy zone, to disrupt its troop command, to neutralize the artillery-mortar grouping, to check the maneuvering of the enemy operational and tactical reserves and defeat them as they approach the battlefield. This will support the army troops in quickly and decisively carrying out the tasks of piercing the enemy defenses on the Luostari sector and defeating its forces in the Petsamo area. Considering the mountainous terrain and the strength of the enemy defensive works (from stone and granite), the bomber aviation is to be equipped with high-explosive bombs weighing 500, 250 and 100 kg.

The crossings over the Titovka River are to be destroyed in its middle courses in the aim of preventing the maneuvering of enemy reserves and the withdrawal of its forces from the Bolshaya Litsa area to the west to the Petsamo area.

Enemy aviation is to be destroyed at its airfields.

In the course of the defensive, the infantry and tanks are to be escorted on the battlefield, preventing the planned enemy pullback to intermediate lines, checking counterattacks by enemy reserves, destroying the communications centers, command posts and mobile equipment which could be employed in the aim of launching an attack against the flank and boundary areas of the advancing troops.

Tanks and motorized infantry are to be covered during the period of developing the operation and initiating actions in pursuit of a retreating enemy....

Engineer support. The main task of the engineer troops is to prepare the assembly area for the army advance, to ensure rapid and organized crossing of water barriers by the troops in the Luostari sector (the Titovka River, the Petsamo-Yoki River), the maneuvering of the advancing troops after breaking through the enemy defensive area and the reinforcing of the lines occupied by them.

In supporting the maneuver of the advancing troops, chief attention is to be paid to organizing direct escort for the troops in developing the offensive, the demarcation of the tactical and operational obstacle areas and the covering of the flanks of the army and advancing units and formations by obstacles.

The command post of the army is in the area of Lake Nozh-Yavr. The army communications artery is Luostari.

Commander of Karelian Front,  
Army Gen Meretskov

Military Council Member of Front,  
Lt Gen Shtykov

Front Chief of Staff,  
Lt Gen Krutikov

TsAMO, folio 214, inv. 1437, file 1361, sheets 29-37.

COPYRIGHT: "Voyenno-istoricheskiy zhurnal", 1985

10272

CSO: 1801/272



ON WORK METHODS OF ALL-ARMS COMMANDERS, STAFFS IN ORGANIZING OFFENSIVE COMBAT  
IN 1930'S

Moscow VOYENNO-ISTORICHESKIY ZHURNAL in Russian No 6, Jun 85 (signed to press  
28 May 85) pp 52-57

[Article by Candidate of Historical Sciences, Lt Col V. A. Daynes, published  
under the rubric "Scientific Papers and Information"]

[Text] The technical reconstruction and organizational reform of the Soviet  
Armed Forces in the 1930's, the development of military art, including the  
elaboration of a theory of deep combat and a deep operation and the  
introduction of its provisions into combat training practices had a  
substantial impact upon the work methods of the all-arms commanders and staffs  
in organizing offensive combat.

In accord with the provisions of the 1936 RKKA [Worker-Peasant Red Army]  
Provisional Field Manual, offensive combat against the enemy on the defensive  
could develop under diverse situational conditions: from the approach to the  
defensive area, from a line of direct contact with the enemy and in addition  
be conducted against the enemy which had gone over to the defensive in a  
meeting encounter or which put up successive resistance on definite lines in  
retreating and pulling out of battle.(1) In the 1930's, greatest attention  
was given to working out the offensive from an approach to the enemy  
defenses.(2) With this method time for organizing offensive combat was  
limited and this required the use of the most efficient work methods.  
According to the views of those times, the organization of combat included a  
studying of the given mission, an analysis of the situation, the taking of a  
decision, the giving of missions, the organization of cooperation and command,  
combat, engineer, chemical and logistical support as well as the organizing of  
political work.(5)

The most important command function in organizing offensive combat was the  
taking of a decision by the commander and on the basis of this the staff,  
together with the other command bodies, planned the combat. The 1936  
Provisional Field Manual demanded in taking decisions that they keep within  
such times so that the staffs of the divisions and regiments as well as the  
artillery chief of the division would have several hours of daylight to  
organize combat, particularly cooperation.(6) As a rule, the commanders of  
the rifle units and formations spent from 2 to 5 hours taking a decision,

granting the subordinate commanders at least 2 or 3 hours of daylight to organize combat.(7) This experience was taken into account in working out the draft of the new 1939 Field Manual. Here as a compulsory requirement it was stated that for the work of the artillery headquarters bodies and the regimental staffs and, most importantly, for practical organization of the cooperation of the battalions with the artillery and tanks in the field, it was essential to provide at least 2 or 3 hours of daylight, if the offensive was planned for the same or following day.(8)

In the 1930's, proceeding from the experience of exercises and maneuvers, the following procedure became established for the work of commanders in decision taking: after receiving the combat order or instructions of the senior chief, the all-arms commander initially studied the given task, that is, with exhaustive thoroughness established what was the task of the superior formation, what was the goal of its actions, what was required from his own formation (unit), its place in combat, the conditions for combat cooperation with adjacent units and with the resources of the senior chief (aviation, long-range artillery, tank formations and so forth). Then he assessed the situation and as a result of this determined: the forces, position, grouping, condition, technical equipping and nature of expected actions by enemy troops; the condition, position and capabilities of his own troops, including attached reinforcements, the necessary regroupings and other measures related to increasing combat readiness.

By a comparison of his own forces and capabilities with the forces and probable capabilities of the enemy, the balance of forces of the sides could be established. A study of the terrain made it possible to know to what degree its particular features contributed to or impeded the carrying out of the combat mission and what measures must be carried out for equipping the terrain in the interests of the forthcoming actions. In addition, an assessment was made of the hydrometeorological conditions, the season and time of day, the sociopolitical composition of the population in the area of forthcoming combat.

After studying the received task and a thorough assessment of the situation, the commander took the decision for combat. Here particular attention was paid to the promptness of decision taking. "Incomplete information about the situation," as was emphasized in the 1936 Provisional Field Manual, "does not release the commander from responsibility for prompt decision taking."(9) In a number of instances, as was envisaged by the Provisional Regulation Governing the Field Service of Troop Staffs, preliminary orders were issued before the taking of the decision.(10) These were aimed at warning the troops about the pending task as well as about the time of the offensive and the readiness of the troops for it. This made it possible for subordinates to possess a larger amount of daylight to prepare for offensive combat and helped in promptly carrying out the combat mission. The decision, as a rule, was made using a map. If the situation permitted, then a preliminary decision was adopted and this was subsequently adjusted in a personal reconnaissance of the field.(11) In particular, this was how the commanders of the Moscow Proletarian Rifle Division in 1930 and the 48th Rifle Division in exercises in 1933 organized their work.(12) In both instances the reconnaissance involved

the commanders of the subordinate, attached and supporting units and subunits as well as the representatives of the branches of troops and services.

The all-arms commanders finally formulated their plan for the forthcoming offensive in the presence of those persons who had worked out the battle order and carried out measures to support combat actions.(13) This made it possible to more quickly formulate the decision and issue it to the troops. Regardless of the fact that a whole series of officials participated in preparing the data for decision taking, the commander, in accord with the requirements of the manual, made the decision individually. The essence of the decision was to determine "for what (for what purpose) and how the main efforts of the troops are to be employed and how they are to be supported by auxiliary actions."(14) The main requirement on the commander's decision was that it briefly but also precisely and clearly expressed the main idea of the defeat of the enemy by the formation (unit) in full accord with the task set by the senior chief.

The commander's decision was written down by the chiefs of the operations department, the signals department and the rear of the formation. All the remaining staff commanders plotted it on their working charts. After this the operations department immediately set to working out the combat order, the chief of the rear drew up an order and individual instructions for the rear services and the signals chief prepared instructions for organizing communications. Instructions on these questions of command, combat and logistical support were issued by the commander after announcing the decision.

In order to accelerate the process of bringing the adopted decision to the executors and ensuring the prompt start of work in carrying out the combat order, preliminary instructions were also issued. These were issued to the troops usually by communications equipment. The preliminary instructions gave: the initial position an immediate task, the time for commencing action, with what units one would be fighting together (who would be subordinate, who would be supported) as well as how to establish contact with them.(15) At the same time instructions were worked out on air, antitank and antichemical defense as well as an operational timetable and sketch maps and plans for political work to ensure the combat activeness of the troops, plans for the artillery and air softening up for the attack, signals documents and others.(16) In the aim of shortening the time required to work out the planning documents, formalized blanks were prepared ahead of time for orders, the orders of march of the enemy forces, lists of the balance of forces and so forth. In those instances where because of situational conditions it was impossible to work out the written combat documents fully, notes were made on the working maps of the commanders as well as entries in their field booklets.

An important measure in the work of the all-arms commanders and staffs was the issuing of combat missions to the troops in strict observance of secrecy and even more timeliness. The Provisional Regulation on Field Service of Troop Staffs ordered that the staffs organize their work of issuing instructions in such a manner that they reached the executors in the shortest possible time. "The staffs do not have the right to take a single extra minute away from the troops for their work of issuing instructions," stated the Provisional Regulations. "For this reason, the chief of staff, in organizing the issuing

of orders, each time should determine how much time remains for the troops before starting the fulfillment of the order and, proceeding from this, to establish a method and sequence of transmitting the orders and instructions which would provide the troops with the required time to prepare and promptly carry out the order."(17)

The experience of the exercises in the 1930's shows that the commanders and staffs employed various methods of issuing the order. The most effective was the verbal giving of orders personally by the senior chief in the reporting of summoned subordinate commanders to his observation post.(18) The official manuals prohibited a delay in issuing orders and instructions to the troops due to a desire to work out these documents in a written form.(19) A written combat order was issued in those instances when there was time to work it out and with prompt delivery to executors. All orally issued (by telephone, radio and telegraph) orders and combat instructions were written down without fail and then duplicated by another method (by written instructions, a liaison officer and so forth). However, the executor did not have the right to wait for the duplicating instruction. He was immediately obliged to begin carrying out the verbally received mission. This can be seen from the experience of the staffs of the I Rifle Corps in 1930, the 24th Rifle Division in 1935 and so forth.(20)

In utilizing communications equipment to issue missions to the troops, the staffs endeavored to shorten the amount of information to be transmitted by employing procedure and brevity code charts and coded maps observing the requirements of covert troop command and control.(21)

In the work of the all-arms commanders and staffs, a significant place was held by the questions of organizing cooperation among all the branches of troops fighting on the same sector to the entire depth of combat and coordinating the actions of the units advancing on different axes.(22) In the first half of the 1930's, responsibility for the organization of cooperation was placed on the chief of staff by the Field Manual.(23) However, the troop practices of the Belorussian, Moscow and other military districts indicated that cooperation was basically organized personally by the commanders of the units and formations(24) (subsequently this was reflected in the draft Field Manuals of 1939, 1940 and 1941(25)). Of all the employed methods, the main one was the organization of cooperation on the map with its subsequent obligatory clarification in the field (in detail to a depth of the farther mission and generally with the development of combat deep in the enemy defenses).(26)

If time for organizing combat was extremely limited, cooperation was usually organized by the method of issuing instructions personally by the commander simultaneously with the setting of missions or transmitting them via the chief of staff and the staff commanders as well as over the communications equipment in brief combat orders or instructions. This method, for example, was employed by the commander of the 40th Rifle Division of the Siberian Military District in 1930 and by the commander of the 24th Rifle Division of the Kiev Military District during maneuvers in 1935.(28)

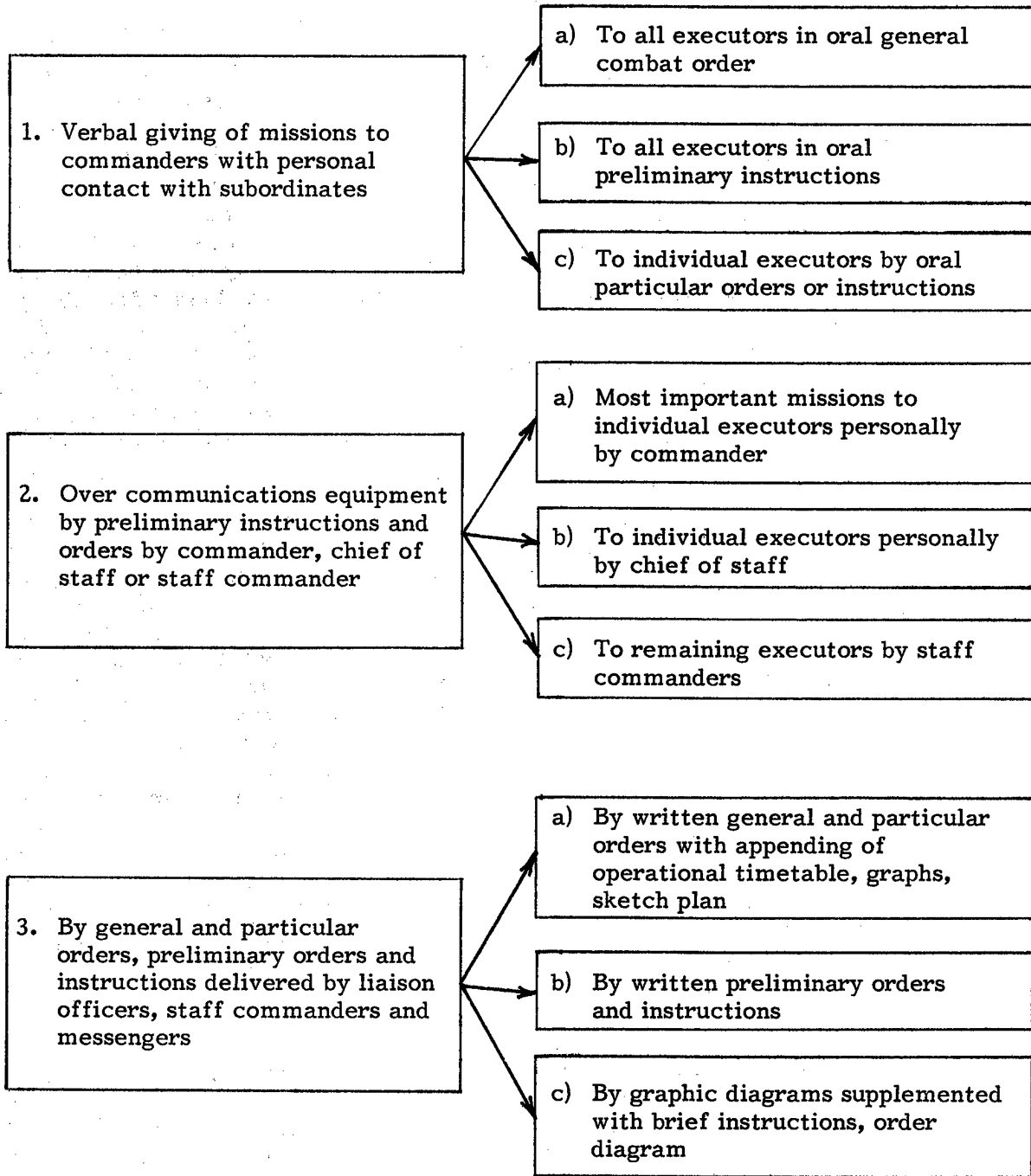

### Methods of Issuing Combat Orders to the Troops

The questions of cooperation were reflected in various forms of documents: on the work maps of the commanders and chiefs of staff, in the operational timetable and the cooperation diagram. The operational timetable was worked out in a rifle corps and division. Appended to it was a sketch chart which was sent out to all inferior commanders down to the level of the company commander.

The experience of exercises in the Siberian, Ukrainian, Moscow and other military districts shows that the chief of staff played a significant role in supporting the commander's work in the area of organizing cooperation. In certain instances, as was required by the manuals and regulations, he was personally concerned with coordinating the efforts of the branches of troops. If these questions had been settled by the commander, the chief of staff wrote down or transmitted his instructions, he directed the elaboration of the appropriate documents, he organized the ensured reliable communications between the cooperating units and subunits and carried out the required calculations.

Important significance was given to working out the questions of cooperation at special exercises and drills for the different forces. For this purpose for the period of the training year units and formations from other branches of troops and special troops were assigned to the all-arms units and formations. For example, in the Belorussian Military District for the 1930 training year, air detachments were assigned to the rifle regiments and these operated together with them in all exercises.(30)

It must also be said that in the 1930's the commanders and staffs gained definite skills in organizing offensive combat from a position of immediate contact with the enemy. More attention began to be given to this method of advance on the eve of the Great Patriotic War proceeding from the combat experience of Khalkhin-Gol and during the Soviet-Finnish War. In contrast to the previously examined main method (going over to the offensive from an approach to the enemy defenses), in an offensive from a position of direct contact with the enemy, a number of characteristic distinctions in the work of the commanders and staffs became apparent. In the first place, from the experience of the exercises of the XVII Rifle Corps and the 24th Rifle Division of the Ukrainian Military District in 1934, the XIV Rifle Corps of the Kiev Military District in 1936 as well as other formations, the commanders and staffs had 20-30 and more hours to organize offensive combat by the second method.(32) This made it possible to work out in detail the questions of command and control in all levels. Secondly, preliminary orders, if they were prepared, were issued only after the commander had taken the decision for combat.(33) Thirdly, the main method of issuing tasks to the troops was the verbal giving of them personally by the commander in the field but with the obligatory drawing up of a written combat order. There was also the extensive practice of trips by the commanders of the all-arms units and formations to the troops for helping subordinates in organizing combat. Fourthly, cooperation among the branches of troops was organized directly by the all-arms commander solely in the field. Reconnaissance was conducted without fail. Here cooperation was organized in detail not to the depth of the further task, as before, but to the depth of the immediate task. The importance given to the questions of cooperation can be seen from the fact of

including in the draft field manuals of 1939, 1940 and 1941 a special section entitled "Cooperation of the Branches of Troops on the Offensive."

Thus, in the 1930's significant work was done to seek out the most effective methods for organizing offensive combat by the all-arms commanders and staffs both from an approach to the defenses as well as from a position of immediate contact with the enemy. In assessing what had been achieved, the USSR People's Commissar of Defense, MSU K. Ye. Voroshilov, in an order of 14 December 1937 commented that the commanders of the all-arms formations, as a rule, showed good examples of control of combat and cooperation among the branches of troops in offensive combat had also been improved and this had been aided by the careful organization of the offensive.(34)

At the same time, in the work of the all-arms commanders and staffs there were also definite shortcomings. Among them was an uncertain knowledge of the regulations and manuals, including the Provisional Manual on Field Service of Troop Staffs, insufficient practical skills in the organizing of reconnaissance, signals and so forth.(35) In the aim of eliminating these the USSR People's Commissar of Defense demanded that measures be taken to improve the training of the command and supervisory personnel in the course of commander training. For this reason during the prewar period a large number of command and staff exercises and command-staff field trips were made with communications and reconnaissance equipment and dummy troops, in addition to staff drills, military games and field trips. In the course of carrying out these measures, the all-arms commanders and staffs, under conditions as close as possible to actual combat, learned to organize combat, paying particular attention to the questions of organizing cooperation, reconnaissance and communications.(36) As a result the effectiveness of the work done by the commanders and staffs in organizing offensive combat was improved. The experience of exercises of the Moscow, Transbaykal, Western Special and certain other military districts showed that by the start of the Great Patriotic War the organization of cooperation had been improved on the regiment-division level and the staffs were taking a more active part in working out the decision.(37)

In conclusion it must be pointed out that the work methods employed in the 1930's by the all-arms commanders and staffs in organizing offensive combat basically proved themselves during the period of the Great Patriotic War. Their continuous improvement during the designated period was subordinate primarily to the search for ways for reducing the time spent on the taking of a decision by the commander and transmitting it to the troops. This trend as well as the direction of the searches in the given area have been maintained today.

#### FOOTNOTES

1. "Vremennyy Polevoy ustav RKKA 1936 (PU-36)" [RKKA Provisional Field Manual of 1936 (PU-36)], Moscow, Gosvvoenizdat, 1937, p 95.
2. TsGASA [Central State Archives of the Soviet Army], folio 900, inv. 1, file 73, sheets 94-98; folio 25871, inv. 2, file 558, sheet 9; folio

- 25880, inv. 4, file 34, sheet 9; folio 25883, inv. 3, file 559, sheet 62.
3. [not in text]
  4. [not in text]
  5. "Obshchaya taktika" [General Tactics], in 3 volumes, Moscow, Voenizdat, Vol 1, 1940, pp 15-16.
  6. "Vremenny Poleyoy ustav....," pp 107-108.
  7. TsGASA, folio 4, inv. 1, file 1470, sheets 55-56; file 1519, sheet 1; inv. 2, file 507, sheet 167; folio 25888, inv. 3, file 492, sheet 18; folio 31983, inv. 1, file 5, sheets 78-88.
  8. "Poleyoy ustav RKKA (PU-39). Proyekt" [RKKA Field Manual (PU-39). Draft], Moscow, Voenizdat, 1939, pp 144-145.
  9. "Vremenny Poleyoy ustav....," p 71.
  10. TsGASA, folio 900, inv. 1, file 292, sheet 129; folio 30738, inv. 1, file 26, sheet 127; "Vremennoye nastavleniye po polevoy sluzhbe voyskovykh shtabov" [Provisional Regulation on Field Service of Troop Staffs], Moscow-Leningrad, Otdel izdatelstva NKO SSSR, 1935, pp 70-71.
  11. "Obshchaya taktika," Vol 1, p 18.
  12. TsGASA, folio 25883, inv. 3, file 559, sheet 132; folio 31982, inv. 1, file 5, sheets 86-88.
  13. Ibid., folio 900, inv. 1, file 73, sheet 94; folio 25880, inv. 4, file 78, sheets 9, 268; folio 25883, inv. 3, file 559, sheets 62, 132; folio 31899, inv. 3, file 59, sheet 177.
  14. "Obshchaya taktika," Vol 1, pp 17-18.
  15. "Vremennoye nastavleniye po polevoy....," p 71; TsGASA, folio 900, inv. 1, file 292, sheet 138.
  16. TsGASA, folio 900, inv. 1, file 292, sheet 139; folio 25871, inv. 2, file 558, sheet 9; folio 25880, inv. 4, file 34, sheet 9; folio 31899, inv. 3, file 59, sheet 47.
  17. "Vremennoye nastavleniye po polevoy....," p 68.
  18. TsGASA, folio 25880, inv. 4, file 47, sheet 289; folio 25883, inv. 3,] file 556, sheet 79.
  19. "Vremennoye nastavleniye po polevoy....," p 69.



20. TsGASA, folio 4, inv. 1, file 1470, sheet 212; folio 900, inv. 1, file 75, sheet 133; folio 31899, inv. 3, file 59, sheet 177; file 64, sheets 414, 605.
21. Ibid., folio 4, inv. 15, file 9, sheet 354; folio 25880, inv. 4, file 45, sheet 333.
22. "Vremenny Polevoy ustav...", p 10.
23. See: "Polevoy ustav RKKA. 1929" [RKKA Field Manual. 1929], Moscow-Leningrad, Gosvoenizdat, 1932, p 20.
24. TsGASA, folio 4, inv. 1, file 1365, sheets 11, 43; file 1470, sheet 248; folio 25871, inv. 2, file 750, sheet 29; folio 25883, inv. 3, file 545, sheet 10; folio 31899, inv. 3, file 48, sheet 13; folio 33989, inv. 1, file 80, sheet 2.
25. "Polevoy ustav RKKA...", pp 155-156, 157; "Polevoy ustav Krasnoy Armii 1940 g. Proyekt" [Red Army Field Manual of 1940. Draft], Moscow, Gosvoenizdat, 1940, pp 139-140; "Polevoy ustav Krasnoy Armii. Proyekt" [Red Army Field Manual. Draft], Moscow, Voenizdat, 1941, pp 117-121.
26. TsGASA, folio 900, inv. 1, file 292, sheet 140; folio 25880, inv. 4, file 44, sheet 9; folio 31899, inv. 3, file 59, sheets 177, 180-182.
27. [not in text]
28. TsGASA, folio 25880, inv. 4, file 23, sheet 9; folio 31899, inv. 3, file 59, sheets 143, 177; file 64, sheets 280, 421; file 70, sheet 56; folio 31983, inv. 1, file 5, sheets 80, 86-88.
29. [not in text]
30. TsGASA, folio 25871, inv. 2, file 750, sheet 29.
31. [not in text]
32. TsGASA, folio 900, inv. 1, file 292, sheet 129; folio 25880, inv. 4, file 78, sheet 266; folio 30738, inv. 1, file 26, sheet 129; folio 31899, inv. 3, file 64, sheet 421.
33. Ibid., folio 900, inv. 1, file 299, sheet 85.
34. Ibid., folio 4, inv. 15, file 82, sheet 232.
35. Ibid., inv. 3, file 3305, sheet 90; inv. 15, file 19, sheet 353; file 77, sheet 144; file 82, sheet 233; folio 1103, inv. 1, file 46, sheet 105; folio 30738, inv. 1, file 29, sheets 95-96.
36. Ibid., folio 4, inv. 3, file 3300, sheet 77; file 3302, sheet 120; inv. 15, file 19, sheet 360; file 77, sheets 145-146; file 82, sheets

603-604; folio 25880, inv. 4, file 81, sheets 1, 196; folio 25883,  
inv. 4, file 728, sheet 1.

37. Ibid., folio 25871, inv. 2, file 30, sheet 41; folio 25880, inv. 4,  
file 353, sheet 40; folio 25883, inv. 4, file 728, sheet 1; folio 30738,  
inv. 1, file 25, sheet 25.

COPYRIGHT: "Voyenno-istoricheskiy zhurnal", 1985

10272

CSO: 1801/272

## COMBAT OF DNIEPER NAVAL FLOTILLA IN BELORUSSIAN OPERATION

Moscow VOYENNO-ISTORICHESKIY ZHURNAL in Russian No 6, Jun 85 (signed to press 28 May 85) pp 57-62

[Article by Capt 1st Rank A. P. Aristov]

[Text] In April 1944, by a decision of Hq SHC, the Dnieper Naval Flotilla (commander, Capt 1st Rank V. V. Grigoryev) which prior to this had been in operational subordination to the command of the Second Belorussian Front, in operational terms was transferred to the command of the First Belorussian Front(1) and the flotilla was to cooperate with the troops of this front in the course of the Belorussian Operation on the Bobruysk and Pinsk Sectors.

In accord with the directive from the commander of the First Belorussian Front, from 12 June 1944(2) the ship forces of the flotilla were given the following tasks: on the Bobruysk Sector, to provide artillery fire in supporting the offensive by the left-flank units of the 48th Army and the right-flank units of the 65th Army; to pursue the retreating enemy along the Berezina in the general direction of Bobruysk; to provide assistance to the units of the 48th and 65th Armies in crossing the Berezina; to organize antimine defenses (PMO) on the river; on the Pinsk Sector to provide help to the 61st Army in splitting the units of the 2d Nazi Army, encircling them and defeating them in the centers of resistance of Luninets and Pinsk; to support units of the 61st Army in the littoral areas of the Pripyat.

The preparation of the flotilla to participate in the operation and the planning of its combat operations were carried out ahead of time. In the course of this chief attention was given to organizing fire support from the naval artillery to the units and formations of the ground forces, to transporting personnel and equipment across the water obstacles as well as to working out the methods for destroying the enemy crossings and so forth.(3)

The flotilla commander assigned the most battleworthy formation for combat on the Bobruysk Sector, the 1st Brigade of River Vessels (commander, Capt 2d Rank S. M. Lyalko). Due to the numerous, well fortified riverside enemy strongpoints along the Berezina, the 1st Brigade was reinforced with vessels from the 2d and 3d Brigades. As a total 13 armored launches, 10 minesweeping launches, 12 patrol boats, 12 hydroplanes and the 293d Separate Antiaircraft Artillery Battalion were concentrated on the Berezina.(4) In the course of

combat, 3 armored launches, 5 floating batteries and 10 air defense launches were additionally brought here.(5)

In planning combat on the second sector, one must particularly note the shifting of the boats from the Berezina to the Pripyat and the landing of a party in the Pinsk Riverport. The flotilla staff set the route of the move, the formation, and planned measures to organize reconnaissance, air and antichemical defenses as well as defense against enemy firing positions on the shore; it established and issued to the ship commanders signals for the maneuvering of the forces and fire. All the flotilla ships were to fight on the Pripyat. Proceeding from this the plan for cooperation with the ground forces was drawn up.

In preparing for the operation, the flotilla command conducted staff exercises, drills, games and tactical quizzes using maps and mock-ups and organized reconnaissance trips for the officers in the field. The combat experience of the other river flotillas was studied. The aims of all these measures which were often conducted together with the cooperating ground units were: precise coordination of actions on the battalion-to-battalion, ship-to-ship and ship-to-company level; to increase the ship commanders' skills in practical actions in an unforeseen combat situation and the ability to take enterprising, bold decisions. In order to accelerate the replenishing of supplies for the boats, some 7-10 km from the front line, a maneuvering rear base of the flotilla was established.

Great attention was paid to organizing command and control. For example, on the Bobruysk Sector the flotilla staff had in Rechitsa a flagship command post (FKP). In Yakimovaya Sloboda there was an auxiliary command post (VPU) at which the flotilla military council was located.(6) The flotilla staff also had contact with the main command post of the front and with the army staffs.

On 14-21 June, the staffs of the cooperating formations--the 1st Brigade of River Vessels and the CV and LIII Rifle Corps adjusted the plans for their joint actions. Particular attention was paid to achieving coordinated actions between the land and ship artillery in the various stages of the offensive. In line with this, the fire plan was worked out with particular care. It indicated the targets and established the approximate consumption of shells.

With the start of the offensive by the front, the armored launches, having covertly taken up their positions, opened fire against the designated targets. In a brief interval of time they destroyed an ammunition dump, silenced five artillery and mortar batteries and destroyed nine covered trenches.(7)

In the second day the 1st Brigade was given the mission of eliminating the enemy grouping threatening the flank of the advancing troops in cooperation with the CV Rifle Corps of the 65th Army in the area of Zdudichi--Parichi. In order to carry out this mission, it was decided to land a tactical assault force in the area of the village of Zdudichi. At 2015 hours of 25 July, four armored launches and two minesweeping launches from the 2d Separate Guards Battalion of Armored Launches (commander, Capt 3d Rank A. I. Peskov) took on board two platoons of submachine gunners, a mortar platoon and a machine gun platoon and crews of the correction posts of the 2d Division of Armored

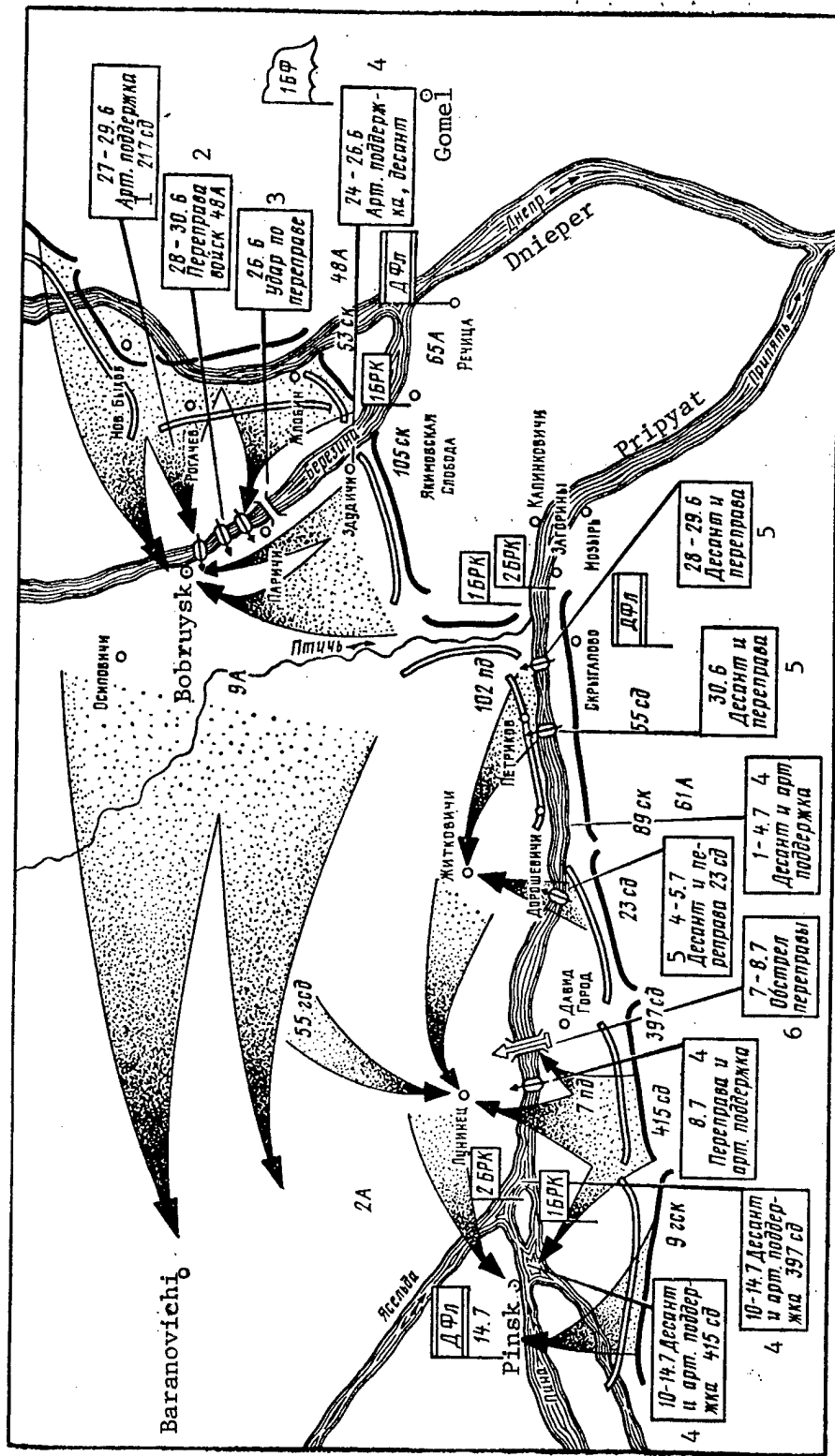

**Missions Carried Out by Dnieper Naval Flotilla in Belorussian Operation**

- Key:**
- 1--Artillery support
  - 2--Ferrying of troops
  - 3--Attack against crossing
  - 4--Artillery support, assault landing
  - 5--Assault landing and crossing
  - 6--Firing on crossing

Launches (a total of around 100 men) and began to move up the Berezina. In approaching Zdudichi the enemy opened heavy fire against them. The armored launches set a smokescreen but prior to this their artillery succeeded in neutralizing the enemy firing points located by the water's edge. The first wave group of the landing force without a pause captured the first three trenches and dug in firmly on the bridgehead. During the night of 26 June, another 100 men were landed here. Some 90 minutes later, units from the 193d Rifle Division from the south and the 96th Rifle Division from the southeast went over to the offensive. The boats supported them with aimed fire.(8)

After abandoning Zdudichi the enemy endeavored to check our troops on the approaches to Parichi. The crossing which survived here made it possible for the enemy to maneuver its forces. The 1st Brigade was to destroy the crossing. The carrying out of this mission was complicated by the fact that the units cooperating with it, in pursuing the enemy, had moved away from the river channel. Contact with them was disrupted. It was essential to rely on their own forces. The brigade commander took a decision which was approved by the flotilla military council, namely: to independently break through to Parichi and destroy the crossing. The enemy endeavored to halt the movement of the armored launches from the 2d Division to the objective by a fire screen. Some 20 guns and 2 tanks continuously fired on the river channel by the population point of Belcho. By the firing of rockets, artillery and machine guns the armored launches neutralized enemy resistance and by 1600 hours had broken through to the Parichi Bridge across the Berezina. From a range of 300-400 m, they began to fire on the enemy tanks, assault guns and motor vehicles which were attempting to cross the river. A jam was formed on the bridge and the crossing was disrupted. The enemy, realizing the danger of the developing situation, immediately brought up assault guns to the bridge and opened return fire against the launches. Enemy mortar batteries joined in the battle which lasted more than 90 minutes. The armored launches had to maneuver and retreat behind the protruding point of the left bank and cover one another. Although five armored launches sustained direct hits, their crews carried out the set missions, destroying the enemy crossing over the Berezina and facilitating the offensive actions of our troops.

In the aim of the more active pursuit of the enemy which was being rolled back from Parichi to Bobruysk and for reinforcing our battle formations, the command of the 48th Army took the decision to shift units of the 217 Rifle Division from the left bank to the right. This mission was carried out by a detachment of armored launches which subsequently provided fire support to the troops which had crossed.

As a result of the active joint operations of the 217th Division and the naval forces, the southern part of Bobruysk was liberated and thus the crossing of units from the 48th Army directly to the city was ensured. By 1200 hours of 29 June, Soviet troops had completely cleared the enemy from the town. With this the combat of the 1st Brigade of River Vessels on the Berezina ended. During the following 2 days the ships of the brigade transported troops across the river. As a total on 29-30 June, they transported 66,000 men, 1,350 guns (including up to 122-mm) and mortars, 500 vehicles with ammunition and freight, around 7,000 carts and 7,000 horses.(9)

The encirclement and defeat of the Bobruysk Nazi troop grouping created good conditions for active offensive operations by the 61st Army which was to the south of the right bank of the Pripyat River. All the forces of the Dnieper River took part in the offensive together with the army troops.(10)

In the capture of Pinsk, plans were made to land an assault force in the city's riverport. For this the landing forces had to break through deep into the enemy defenses for more than 20 km. The open, swampy riverside terrain which could be seen 10 km away from elevated points in the city reduced the secrecy of the move, it almost deprived our troops of surprise and impeded cooperation of the ships with units from the 61st Army. Since the field artillery due to the long range was unable to help the landing force, fire support was entrusted to a detachment of ships (six floating batteries and six armored launches).(11)

In the evening of 11 July, launches from the landing detachment (commander, Capt 3d Rank A. I. Peskov) in the area of Lemeshevichi took on the first wave of the landing force numbering 550 men from the 415th Division as well as ammunition and artillery.(12) Then they covertly moved deep into the enemy defenses. The launches under the command of Guards Lt N. Il. Buramenskiy, I. A. Chernozubov and Ye. P. Kaliusha were some of the first to land the party (around 0300 hours on 12 July). The armored launches and floating batteries from the artillery support detachment (commander, Capt 3d Rank K. V. Maksimenko) provided fire support for the actions of the landing party.

By 0800 hours, the southeastern part of the city had been liberated. For exploiting the success it was immediately necessary to have reinforcements which did not arrive on time. In benefiting from this, the Nazis moved up reserves and went over to a counterattack, pressing the landing force to the northeastern part of Pinsk. The second wave of the landing force was organized by the command only in the second half of the day. When two launches (commanders, Lts A. M. Yevgenyev and I. A. Chernozubov) with the second wave of the landing party approached the landing area, they came under heavy fire. As a result one launch was sunk and the second sustained damage.(13) In the course of combat the landing party repelled numerous enemy attacks.

During this time ships from the 2d Brigade, moving up the Yaselda and Pina Rivers, supported the advance of units from the 397th Division. They neutralized the artillery and mortar batteries and firing positions, they destroyed personnel and combat equipment and landed reconnaissance and tactical parties. The 200 fighters landed at dawn on 14 July near the village of Pinkovichi, routed the garrison of the strongpoint and cut the escape route for the Nazi units to Pinsk and this made it possible for the main forces of the 397th Division without a delay to move right up to the city and in the morning link up with the landing party.(14)

By 0800 hours on 14 July, by the joint efforts of the rifle formations and the flotilla ships, the city of Pinsk, a major center of resistance on the path to Brest, was fully cleared. With its liberation the involvement of the Dnieper Flotilla in the Belorussian Operation ended, since the hydroengineering works

of the Dnieper-Bug Canal has been destroyed and the ships were unable to move further up the rivers.

As a total in the course of the Belorussian Operation, the flotilla ships landed 12 reconnaissance and tactical forces numbering over 2,800 men and destroyed around 1,550 soldiers and officers, 19 artillery batteries and 27 mortar batteries, 13 guns, 5 assault guns and 7 tanks, 92 machine gun nests, 16 dumps and 10 cars with ammunition as well as much other equipment and defensive installations. They transported across water barriers some 77,934 soldiers and officers, 960 guns, 8 mortar batteries and 917 mortars, 100 antitank guns, 92 machine guns, 8,663 ammunition boxes, 21 radios, 1,555 motor vehicles and 30 tractors, 8,663 carts, 8,975 horses and 37.7 tons of food.(15)

In conclusion, it must be pointed out that the involvement of the Dnieper Naval Flotilla in the liberation of Belorussia convincingly confirmed that the armored launches comprised the shock force of the river formations, and primarily those armed with the 76.2-mm artillery guns and the M-8-M and M-13-M rocket units. For conducting successful operations they needed combat support from the reinforced shore escort detachments consisting of mobile artillery batteries and naval infantry subunits.

The experience gained by the Dnieper Naval Flotilla in the battles for the liberation of Belorussia helped it in successfully carrying out the missions in subsequent offensive actions of our troops, in particular in the Berlin Operation. Some of its features, in our opinion, have not lost their importance under present-day conditions.

#### FOOTNOTES

1. "Istoriya Velikoy Otechestvennoy voyny Sovetskogo Soyuza 1941-1945" [The History of the Great Patriotic War of the Soviet Union of 1941-1945], Moscow, Voenizdat, Vol 4, 1962, p 450.
2. TsVMA [Central Naval Archives], folio 211, file 1944, sheet 20.
3. Ibid., file 13739, sheet 1.
4. I. I. Loktionov, "Pinskaya i Dneprovskaya flotilii v Velikoy Otechestvennoy voyne" [The Pinsk and Dnieper Flotillas in the Great Patriotic War], Moscow, Voenizdat, 1958, pp 119-122.
5. TsVMA, folio 211, file 35203, sheet 204.
6. Ibid., file 1944, sheet 21.
7. I. I. Loktionov, op. cit., p 128.
8. Ibid., p 130.
9. "Morskoy atlas" [Naval Atlas], Vol III, Military History, Part 2, Moscow, Izd. GSh VMF, 1963, sheet 40.



10. The ships which participated in combat on the Berezina moved to the Pripyat on 30 June-6 July.
11. TsVMA, folio 211, file 12802, sheet 25; "Morskoy atlas," Vol III, Part 2, Description to Maps, p 462.
12. "Boyevoy put Sovetskogo Voyenno-Morskogo Flota" [The Campaign Record of the Soviet Navy], Moscow, Voenizdat, 1974, p 121.
13. TsVMA, folio 211, file 12802, sheet 25; I. I. Loktionov, op. cit., p 172.
14. "Morskoy atlas," Vol III, Part 2, sheet 40A; I. I. Loktionov, op. cit., p 178.
15. TsVMA, folio 211, file 11274, sheets 111, 112; "Morskoy atlas," Vol III, Part 2, sheet 40.

COPYRIGHT: "Voyenno-istoricheskiy zhurnal", 1985

10272

CSO: 1801/272

## WEAPONS SUPPLY OF FRONTS IN BERLIN OPERATION

Moscow VOYENNO-ISTORICHESKIY ZHURNAL in Russian No 6, Jun 85 (signed to press 28 May 85) pp 62-63

[Article by Col Gen (Ret) I. I. Volkotrubenko]

[Text] During the period of preparations for the Berlin Operation, the Main Artillery Directorate (GAU) fully provided the First and Second Belorussian and the First Ukrainian Fronts with weapons and replenished the losses suffered by the troops. The First Belorussian and First Ukrainian Fronts alone received more than 2,000 guns and mortars as well as the lacking firearms. By the start of the operation, the three fronts had more than 2 million rifles and submachine guns, over 76,000 machine guns and around 42,000 guns and mortars.(1)

For the repair of artillery weapons, the fronts had one or two mobile artillery shops deployed in railway cars and for repairing tractors a repair depot and a repair-reconstruction battalion.

The situation with the supply of ammunition for the troops was somewhat different. In the course of the previous operations, the Soviet troops had spent a large amount of ammunition. As a consequence of this at the depots and dumps of the GAU their supplies had declined sharply. A definite shortage had developed of 76-mm and 122-mm shells the consumption of which was particularly high.

Hq SHC obliged the GAU to bring the supply situation of the fronts prior to the start of the Berlin Operation up to four units of fire for the 76-mm and 122-mm shells. But industry in this short time was unable to produce such an amount of ammunition. For this reason, somewhat later Headquarters permitted the GAU to deliver one unit of fire of shells and mortar rounds to the fronts in the course of the operation.

The impossibility of delivering the required amount of ammunition by the start of the operation concerned the GAU workers, the chiefs of artillery supply and the command of the front. In this context I recall the following episode.

During the night of 12 April 1945, in the office of the GAU chief the high frequency phone rang. I picked up the receiver. Speaking was the Commander of the First Belorussian Front, MSU G. K. Zhukov.

"You constantly let me down!" he stated angrily.

"How do we let you down?" I asked.

"You are slow with the howitzer shells," replied the marshal.

"We are so fast with them," I replied, "that two trains with shells have already left the tracks."

Georgiy Konstantinovich [Zhukov] broke into a laugh but then said more calmly:

"Take every measure to accelerate the delivery of howitzer shells to the front."

"We will do everything possible," I assured the marshal.

At the end of the war I had similar talks with other front commanders and often also with the military council members.

During the preparatory period, the GAU dispatched to the First Belorussian and First Ukrainian Fronts almost 11 million shells, more than 292 million cartridges and around 1.5 million hand grenades.(2) By the start of the operation, the fronts had over 15 million shells, 5.5 million hand grenades and more than 1 billion cartridges for firearms. The supply situation of the troops in terms of ammunition in units of fire was uneven. Thus, for the 82-mm mortar shells, this was from 1.3 to 3.0 units of fire, for the 120-mm mortar shells from 1.5 to 2.9, for the 76-mm shells from 1.1 to 2.2, and for the 122-mm howitzer shells from 1.2 to 1.8 units of fire. It is also essential to bear in mind that under orders from the GAU 3.5 million shells were enroute to the front or had been dispatched, including 700,000 76-mm shells, 275,000 122-mm howitzer shells, that is, almost a million of the most frequently used shells.(3)

The artillery supply headquarters of the fronts had under them five-seven field artillery dumps, a rocket ammunition dump and a weapons dump or artillery depot. All of them were located within the front rear areas. Dumps Nos 1381 and 3131 transloaded ammunition from the Soviet gauge to the Western European.

The shallow depth of the operation with the presence of a developed network of good highways in the combat area did not necessitate the moving of the front artillery dumps or the organizing of their new head departments.

The artillery supply services of the armies by the start of the operation had two field artillery dumps. One of them was usually the head one. If there was no such, a head department of a dump was established with the necessary ammunition supply. The head army dumps (and their departments) were located 15-30 km from the front line.

On the First Belorussian Front (chief of artillery supply, Maj Gen Engr-Tech Serv V. I. Shebanin), artillery supply for each all-arms army had three mobile artillery shops which were in the army rear areas and some even in the troop rear areas. The army tractor repair shops were located in the near army rear and in the course of the operation moved up behind the artillery units of the armies, carrying out the necessary repairs.

On the First Ukrainian Front (chief of artillery supply, Col N. Ye. Manzhurin), in the course of the operation for supplying the troops with ammunition they began to widely use mobile units on motor vehicles from the army dumps. Usually these moved along with the army staff and transported ammunition to the divisional dumps upon instructions of the army artillery commander. In the tank armies these mobile units also existed in the corps.

In the rear area of the Second Belorussian Front (chief of artillery supply, Col Ye. N. Ivanov) the sufficiently dense railroad network made it possible to fully handle the internal front movements. However, their volume depended upon the rolling stock of which there was an acute shortage as there was a lack both of cars and steam engines of the Western European gauge. Ammunition had to be unloaded directly onto the ground. Frequently it was dispatched to the front artillery dumps piecemeal and from there was delivered to the armies and troops basically by army transport.

In the course of the Berlin Operation, the fronts consumed a large amount of ammunition. Here more than one-half of all the ammunition (55 percent) was consumed by the First Belorussian Front, 31 percent by the First Ukrainian and 14 percent by the Second Belorussian. The average daily consumption of ammunition was 177.6 carloads on the First Belorussian Front, 111.9 on the First Ukrainian and 47.8 on the Second Belorussian, a total of approximately 337.3 carloads.

Thus, in terms of the intensity of ammunition consumption, the Berlin Operation holds first place among the other operations of the Great Patriotic War. The total expenditure of all types of ammunition, including rocket, on the three fronts was 9,461 carloads over the period of the operation.

#### FOOTNOTES

1. TsAMO SSSR [Central Archives of the USSR Ministry of Defense], folio 81, inv. 12079, file 401, sheets 39-48.
2. Ibid.
3. Ibid., sheet 32.

COPYRIGHT: "Voyenno-istoricheskiy zhurnal", 1985

10272

CSO: 1801/272

REVIEW: GAREYEV ON FRUNZE

Moscow VOYENNO-ISTORICHESKIY ZHURNAL in Russian No 6, Jun 85 (signed to press 28 May 85) pp 80-86

[Review published under the rubric "Criticism and Bibliograph" by Col Gen A. A. Danilevich of the book "M. V. Frunze--voyenny teoretik" (M. V. Frunze--Military Theorist) by M. A. Gareyev, Moscow, Voenizdat, 1985, 446 pages]

[Text] The theoretical development of Soviet military science and military art would be impossible without a thorough historical analysis of the entire process of the evolution of military theoretical views during various stages of Soviet military organizational development. The basic key to this, undoubtedly, is provided by a purposeful study by military cadres of the fundamental works of K. Marx, F. Engels and V. I. Lenin on military questions as well as the experience of the practical activities of the CPSU in the area of organizing the defense of the Soviet state. Also of great importance is an elucidation of the specific contribution of prominent Soviet military figures to the shaping of Soviet military thought and an examination of the ideas voiced by them in light of modern requirements.

Such an approach is all the more essential at present, under the conditions of rapid military-technical progress, since a sound scientific forecast of the development of military affairs over the long run should be based primarily on the scientific-theoretical potential gained in previous years, considering the long-range trends. In this regard of great interest is the recently published major work by Doctor of Military Sciences, Col Gen M. A. Gareyev, devoted to investigating the military theoretical heritage of one of the prominent party and military figures of the Soviet state, the legendary general and outstanding theorist of military affairs, Mikhail Vasilyevich Frunze.

M. V. Frunze lived and worked when a multiplicity of complex problems confronted the Soviet state and the nascent young Soviet military science. In solving these it was essential to follow new, untrod paths. Nevertheless, they were brilliantly resolved by the genius of V. I. Lenin and by the work of many of his associates. Among them a significant role was played primarily by M. V. Frunze whose diverse military practical activities were organically combined with profound research in the area of military theory.

M. V. Frunze penned over 200 scientific works. The range of questions raised in them is unusually broad. They concern all aspects of military affairs including: strategy, operational art and tactics, the organizational development of the Armed Forces, the organization of party political work in the army and navy, military instruction and indoctrination and the preparation of the national economy and population for war. One is struck by the depth and boldness by the ideas advanced by him and the farsightedness of his scientific assessments in determining the nature of the possible military clashes of the Soviet state with the aggressive forces of world imperialism, the directions of development for the Armed Forces and the methods of their combat employment.

The book of M. A. Gareyev for the first time provides a complete and systematic exposition of the military theoretical questions elaborated by M. V. Frunze with their scientific examination. It also traces the dynamics of the subsequent development of the ideas proposed by him right up to our own times. In reading the book one is again persuaded that many of the ideas and concepts voiced by M. V. Frunze in the 1920's have presently maintained their timeliness and are of permanent significance for the military personnel in the work of strengthening and improving the Soviet Armed Forces.

Of course, M. V. Frunze was far from able to predict everything. And this is understandable as the fundamental changes which have occurred in the military-political situation, in the distribution and balance of world military-political forces and the state of the material means for waging war, particularly nuclear and missile weapons, have presently forced a new approach to all aspects of military theory and practice. Nevertheless, we can see that many ideas proposed by him dealt with the distant future. A majority of them is valid at present. Their viability is explained by the fact that they were worked out on a firm basis of Marxism-Leninism, on a knowledge and use of the general development laws of society and on a profound penetration into the internal, permanent ties and relationships in the development processes of military affairs.

In being guided by the works of Marx, Engels and Lenin and in creatively generalizing the experience of military history, M. V. Frunze was able to look ahead and endeavored to show the dialectics in the development of military affairs. He always went primarily into the inner essence of phenomena and endeavored to subordinate them to the logic and objective laws of dialectical materialism. He analyzed the most minute details of military scientific problems, working out his own judgment on each of them.

The book by M. A. Gareyev clearly shows precisely this characteristic trait in the creative hand of M. V. Frunze, making it possible to more profoundly understand his military theoretical heritage and that contribution which he made to the development of Soviet military science and military art.

In analyzing these questions, the author of the reviewed work has raised a broad range of problems. The book examines the entire process of the genesis and development of Soviet military theory, it analyzes the results of its thorough check by the experience of the military clashes forced on the Soviet Union and primarily the experience of the Great Patriotic War, it brings out

the essence of the present-day system of military scientific knowledge and presents grounds for a scientific forecasting of the development of military affairs, the ways of the organizational development and training of the Armed Forces as well as the methods of their strategic and operational employment in the future. This is the particular value of the reviewed work.

In the work a central place has been given over to examining the works of M. V. Frunze on the questions of Soviet military doctrine. As is known, Mikhail Vasilyevich Frunze, relying upon the fundamental ideas of V. I. Lenin, immediately after the Civil War sharply and definitely posed the question of the need to elaborate a unified Soviet military doctrine at the next stage of Soviet military organizational development. This doctrine would fully take into account the new defense tasks confronting the Soviet state. He also established the role of the party and state bodies in carrying out this task. "The state," emphasized M. V. Frunze, "should determine ahead of time the nature of general and, in particular, military policy, set the possible objects of its military aspirations in accord with this and work out and approve a definite plan of statewide activities which would consider the future clashes and predetermine their success by the effective use of the people's energy.

"As for the military apparatus, relying on the statewide program, it should adopt the organizational form which conforms most to the general state aims and by further work create a firm unity among all the armed forces linked from top to bottom to common views both on the nature of military tasks themselves as well as the methods of resolving them."(1)

M. V. Frunze himself took an active part in this complex work. He clearly formulated the main traits of Soviet military doctrine, he disclosed its structure and showed its fundamental distinction from the military doctrines of the imperialist states. He was the first to determine that military doctrine has two interrelated aspects: political and military-technical, and both, but primarily the latter, are in constant development. The works of M. V. Frunze convincingly showed that the requirements of our military doctrine, like the military doctrine of any state, develop objectively and stem from the nature of the state system, the state's domestic and foreign policy and from really existing sociopolitical, economic and geographic conditions and the available means of waging war. The task of military theoretical thought is to generalize these ideas, to reduce them to an ordered system and coordinate them with the demands of military science and military art.

In investigating these ideas and proceeding from them, the author has specifically disclosed the mechanism for the formation and development of the Soviet state's military doctrine and has shown the relationship between military doctrine and military science. He has concluded that only the military doctrines of socialist states can be truly scientific.

The military doctrines of the imperialist states inevitably run into contradiction with the conclusions of true science, they have an overtly aggressive nature and, as a rule, contain elements of adventurism. The imperialists in every possible way conceal their true essence. In contrast to

this, Soviet military doctrine is openly proclaimed. We have no need to conceal it for it expresses the interests of all the people and at its political basis is defensive, it is aimed at defending the socialist fatherland against the aggressive encroachments of imperialism and reflects the noble aims of our domestic and foreign policy.

The author has correctly raised the question of strengthening the mobilizing role of our military doctrine and its influence upon strengthening the army and navy. He has emphasized that the provisions of military doctrine are reinforced by the enormous capabilities of our state which has entered the stage of mature socialism but at the same time they should not be merely proclaimed but also correctly express the entire spirit and sense of military affairs at the present stage of their development, penetrate into the very midst of the Armed Forces and be closely held by the military cadres (pp 420-421).

Of great interest is the study made by the author of the views of M. F. Frunze concerning the possible nature of a war. M. V. Frunze viewed the possible military clashes of the Soviet state proceeding from three factors: 1) the specific socioclass content of a war; 2) consideration of the number of enemies and the size of their forces; 3) considering those technical means which could and should be employed in future wars. On the basis of this, M. V. Frunze, long before World War II, concluded that a war would be protracted and uncompromising, it would assume an all-encompassing, very decisive and fierce nature and would require the enormous straining of the spiritual forces of peoples and the full use of all materiel. He particularly emphasized that in such a war it is impossible to hope that it would be easy and could be ended without enormous efforts and great sacrifices. In assuming the possibility and necessity of using the profound class contradictions within the capitalist world, M. V. Frunze at the same time showed that in the preparation of the nation and the Armed Forces for a war, one must proceed from the most difficult conditions and base one's plans precisely on this.

The correctness of these ideas was completely and totally affirmed by the entire course of the Great Patriotic War. Without any doubt, this conclusion should be constantly considered under present-day conditions in the practical work of strengthening national defense and improving and developing the Armed Forces.

To a significant degree, as is shown in the book, the forecasts of M. V. Frunze were also valid in terms of the possible strategic appearance of a future war. The ideas voiced by him that a new war, in comparison with World War I, would assume completely different forms, develop over enormous expanses and be a highly maneuverable war and that in the course of it the main role would be played by new types of armed forces and branches of troops, primarily aviation and armored troops, are important not only retrospectively but also provide a methodological basis for a forecast assessment of the probable nature of a possible future war.

As is emphasized in the book, also remaining valid over an historically extended period was the conclusion of M. V. Frunze on the organic intertwining in a war of the elements of fluidity and staticness and the necessity of



skillfully employing both offensive and defensive actions on the tactical, operational and strategic scales.

As is pointed out in the work, M. V. Frunze was always a decisive supporter of offensive actions. He felt that only by an offensive was it possible to achieve a final defeat of the enemy, but at the same time emphasized the need of widely employing the defensive, but not only enforced but also in a number of instances deliberately, in the aim of saving forces and decisively concentrating them on the important sectors of the strategic front.

At present, both the offensive and defensive have assumed new forms and a different content. The relationships between them have become more complex as have the methods of their coordinated employment and the transition from defensive to offensive and from offensive to defensive. Considering this, as was pointed out in the work, there must be a further profound elaboration of the actions of the armed forces, but the main principle of mastering all the forms and methods of waging war remains unchanged.

In the work a major place has been given over to the views of M. V. Frunze on the content of military science and particularly its main part, the theory of military art, as well as to examining the relationships between military science and military art, the theory and practice of military affairs.

M. V. Frunze was clearly aware of the enormous role of military science, he constantly cautioned against underestimating it and said that it has an enormous impact upon the practical activities of the military personnel, it opens up great scope for them, it generalizes historical experience and arms the military cadres with a knowledge of the means and methods of resolving practical tasks. However, he was well aware that the ideas of military science cannot be applied in all instances with the same constancy and uniform outcome as the laws of natural sciences. A knowledge of the laws of armed combat facilitates practice, it provides an opportunity to predict and more fully utilize them for achieving the set goals, but at the same time cannot provide an answer as to how to act in one or another situation. Military art is needed for this (pp 144, 145).

In assessing the views of M. V. Frunze on the content of military science, the author points out that war, as a social phenomenon, is investigated by many sciences. Its sociopolitical essence, the most general laws and relationships with other social phenomena are examined by Lenin's teachings about war and the army and stem from all three component parts of Marxism-Leninism. The patterns and phenomena related to the main specific feature of war, as a continuation of politics by the means of armed violence, are a subject of study for military science per se and the military aspects of other sciences. The phenomena and patterns related to the combating of the enemy by non-military forms, that is, economic, ideological and diplomatic, are examined by different social and natural sciences.

One should also note the classification proposed by the author for the system of knowledge concerning war and the army. The value of this classification is that it reflects objective reality and establishes comparatively uniform areas of military knowledge considering their specific features and relationships.

The very important methodological idea is clearly traced that for each science it is important primarily to define its subject and what it directly knows.

Recently, as was pointed out in the work, Soviet military science in its development has attained new heights and has become one of the main factors in increasing the combat readiness of the Armed Forces and improving the nation's defense capability. Nevertheless the new qualitative shift which has occurred now in military affairs places additional demands on military science and broadens the range of scientific problems which need elaboration.

Considering this, the author has raised the question of a rational combination of fundamental and applied research in the area of military affairs so as not only to achieve the quickest resolution to the urgent practical tasks but also establish the necessary backlog for the distant future. The need is also noted of clarifying the structure of military science and a more specific elaboration of its subject and problem-subject classification.

The work gives much room to an analysis of the operational-tactical views of M. V. Frunze and his contribution to the development of the theory of Soviet operational art and tactics. In taking up these questions, the author both from historical positions as well as in light of modern conditions, analyzes the role and place of the theory of operational art and tactics in the general theory of military art, he analyzes their relationship as well as their relationship to strategy and politics and shows how the main principles of Soviet military art arose and developed, what new was contributed by M. V. Frunze to them and how the ideas voiced by him were employed by Soviet generals, commanders and political workers in practice.

Completely valid is the great attention given in the book to an analysis of the views of M. V. Frunze on the questions of the initial period of a war. The author shows that M. V. Frunze foresaw the growing role of this period, and urged a thorough elaboration of its problems as well as the search for ways and methods for the more organized deployment of the Armed Forces and their entry into a war in the most difficult situation. He viewed the initial period in a different light than was characteristic for World War I and predicted the possibility of conducting major operations during this period with the carrying out of important strategic missions. He cautioned against the growing danger of the aborting of a possible strategic deployment as a result of massed enemy air strikes and the actions of its armored forces. Unfortunately, his warnings at that time were not properly assessed and this was seriously reflected in the actions of our troops during the first days and months of the Great Patriotic War.

The works of M. V. Frunze rather clearly sketch out the structure of operations of the Armed Forces in a war, their configuration and methods of conduct under new conditions. On this level at present his works contain many valuable recommendations which could be successfully employed by our military cadres. For example, M. V. Frunze emphasized the importance of the broad and bold maneuvering of men and weapons, the ability considering the specific situations to select the axes of attacks, to boldly concentrate superior forces on them and employ those methods of combat which would make it possible

to deal a decisive defeat to the enemy and would ensure the destruction of the main enemy forces in a short period of time.

He considered the correct distribution of resources to be an indispensable guarantee for success both on the offensive and defensive, he constantly warned against the pernicious desire to be strong everywhere and gave great importance to establishing and utilizing reserves, to promptly increasing the efforts of the forces and to the early preparation for subsequent combat actions in order to conduct the operation without major operational pauses.

As is correctly pointed out in the book, the scientific views of M. V. Frunze brought out theoretical thought to the elaboration in the 1930's by Soviet military art of the theory of a deep operation. This theory in a fundamentally new manner solved the problem of the exploitation of a tactical success into an operational one and organizing the rapid and decisive defeat of the enemy to the entire depth of its formation. The main ideas of this theory, as is known, gained practical employment and underwent further development during the years of the Great Patriotic War. They are of undoubted interest at present.

In a comparison of the ideas of M. V. Frunze with the development of the theory of Soviet military art in the postwar years, it can be concluded that, regardless that fundamental changes have occurred in the theory and practice of armed combat, the methods proposed by M. V. Frunze for approaching a solution to new problems have not lost their importance.

The trend in the development of Soviet military art, the author indicates, under present-day conditions confirms how profoundly right were V. I. Lenin and one of his most talented students, M. V. Frunze, when in the process of revolutionary creativity they shattered all the old that impeded progress but at the same time were decisively against a nihilistic attitude toward previous experience and watched carefully that the appropriate succession was maintained in the development of military science and military art (p 238).

Also widely treated in the book were the theoretical views and practical activities of M. V. Frunze on the questions of the organizational development of the Armed Forces. In being guided by the fundamental ideas of V. I. Lenin, M. V. Frunze always emphasized that the main principle of Soviet military organizational development and the decisive condition for increasing the combat might of the Armed Forces are leadership by the Communist Party over the entire question of strengthening national defense capability. He also actively defended the Leninist ideas on the principles of manning the Armed Forces, their development and training, and stood firmly in favor of maintaining and strengthening a regular army considering the specific historical conditions and the real capabilities of the Soviet state.

M. V. Frunze gave great importance to improving the organizational structure of the Armed Forces, pointing out that the plans of military organizational development should be worked out and implemented considering a rational combination of the various services and branches of troops in the Armed Forces with the predominant development of those which will carry out the main tasks in a future war. He insisted on an immediate rise in the technical equipping

of the army and navy employing all the last scientific and technical accomplishments.

At present, when the revolution in military affairs acutely poses the question of defining the ways for the further development of the Armed Forces over the long-term period, these ideas have gained exceptional significance. They should be constantly considered in examining the question of what the Armed Forces should be, for what should they be trained and how, with the least expenditures, to ensure their maximum readiness and ability to successfully carry out the tasks which could arise in the event of new imperialist aggression.

The book thoroughly examines the questions of the training of the Armed Forces as well as military training and indoctrination. M. V. Frunze considered that the organization of military training and indoctrination in the Soviet Armed Forces should be based completely differently than in the bourgeois armies. He not only established this but also examined the specific ways for carrying out the given task. In the general system of training and indoctrination, he assigned a crucial role to the principles of communist ideological loyalty and party dedication, a unity of instruction and indoctrination and a close link between theory and practice. He emphasized that the Red Army should be indoctrinated and trained on the basis of uniform concepts and uniform views on all the questions related to its activities and tasks.

M. V. Frunze pointed out that in peacetime an army is always confronted with two problems: what to teach the troops and how to teach them, that is, what methods and forms of training and indoctrination should be employed so as to ensure the maintaining of the ability of the army and navy to successfully carry out arising tasks.

These problems, obviously, also confront the Armed Forces now. The book has correctly raised the question of the ways to bring the combat and political training of the Armed Forces and the entire training and indoctrination system as close as possible to the possible conditions of a future war, if the imperialists should start it, as well as clarifying the trend and broadening the range of questions studied, increasing the scope of the conducted exercises and more fully saturating them with practical actions. One should also note the opinion about the need to further improve the planning and organizational procedures for combat and political training considering the more rational use of training time, the broad and constant introduction of new, progressive training methods, the fuller utilization of the modern achievements of pedagogics and psychology in the training process and the establishing of training classrooms, centers and ranges on a qualitatively new material basis.

Also completely valid are the proposals voiced on the main areas of work to further improve the training of officer cadres by adopting a number of organizational measures, working out optimum and realistic training programs, for introducing more advanced training methods as well as more fully utilizing moral incentives which would instill in the officers a critical attitude toward their training, establish a situation of great exactingness and develop creativity and initiative.

Also of great practical activity are the statements of M. V. Frunze quoted in the book on strengthening one-man leadership, military discipline, improving and increasing the effectiveness of party political work which, in the words of M. V. Frunze, always remains "a new, supplementary branch of arms which is terrifying for any of our enemies."(2)

The concluding chapter of the work examines specific questions in organizing military scientific work in the Armed Forces. On this question thoughts are given of M. V. Frunze which have largely maintained their importance now. For example, M. V. Frunze felt that the practical activities of the military cadres and all the bodies and institutions of the Armed Forces should be organically combined and merged with scientific research. For this reason military scientific work cannot be viewed as something separate from the service activities of the generals and officers. It is a most important obligation for all officials. Without it it is impossible to carry out the tasks which confront the army and navy. M. V. Frunze himself was always faithful to this principle. He was one of the most active authors to appear on the pages of the military journals and newspapers, he headed the Military Scientific Society of the Red Army and while serving as people's commissar for military and naval affairs, initiated the most energetic efforts to raise the level of military scientific work both in the central apparatus and in the troops.

At present, the new tasks which confront the Armed Forces require a significant activization of military scientific work. Due to the rapid replacement of weapons and equipment and due to the profound changes occurring in the methods of conducting armed combat, under the conditions where imperialism is endeavoring at any price to achieve military supremacy over the USSR and its allies, there must be an accelerated elaboration of the arising military scientific problems, greater intensity and a broadening of the research front as well as the employment of more effective forms and methods of military scientific work.

The book by Col Gen M. A. Gareyev can aid significantly in achieving this goal. It makes it possible to more profoundly analyze the military theoretical heritage of M. V. Frunze, an outstanding general and military theorist of the Leninist school. It focuses our command personnel on a creative study of modern military theory and practice and on a bold search for ways to resolve the tasks confronting the Armed Forces in the area of increasing their training and combat readiness.

In our view, the reviewed book also contains individual shortcomings. It would have been desirable, for example, to provide a more detailed analysis of the generalship art of M. V. Frunze, his views on the development of tactics in relationship with the development of weaponry and more thoroughly set out the reasons M. V. Frunze saw for introducing and successively strengthening one-man command in the Armed Forces. There should be a more profound investigation of the forms and methods of military scientific activities, the entire system of mass defense work in the nation as well as certain other questions. All of this reaffirms that we must work constantly on studying the military theoretical heritage of M. V. Frunze.

FOOTNOTES

1. M. V. Frunze, "Sobr. soch." [Collected Works], Moscow-Leningrad, Gosizdat, Vol 1, 1929, p 210.
2. Ibid., Vol 2, 1926, p 21.

COPYRIGHT: "Voyenno-istoricheskiy zhurnal", 1985

10272

CSO: 1801/272

REVIEW: KHAMETOV BOOK ON ADM GOLOVKO

Moscow VOYENNO-ISTORICHESKIY ZHURNAL in Russian No 6, Jun 85 (signed to press 28 May 85) pp 86-87

[Review by Candidate of Historical Sciences, Adm (Ret) S. Ye. Zakharov of the book "Admiral A. G. Golovko" by M. I. Khametov, Moscow, Voenizdat, 1984, 208 pages]

[Text] The name of Adm Arseniy Grigoryevich Golovko rightfully stands among the names of the major military chiefs who played a prominent role in the organizational development and strengthening of the Soviet Armed Forces and in defending the socialist fatherland. A number of works has been devoted to a description of his life and activities. During the days of the preparations for the 40th anniversary of the Great Victory their number has been added to by a book written by the military journalist M. I. Khametov "Admiral A. G. Golovko" published by Voenizdat in the series "Soviet Generals and Military Chiefs."

The book provides an integral notion of the vivid and diverse life and activities of A. G. Golovko. Presented to the reader is an image of an ardent Soviet patriot, a steadfast communist who has devoted all his knowledge, capabilities, strength and energy for the sake of the triumph of the great cause of the Leninist party.

From his early years, A. G. Golovko was in the midst of the struggle to reorganize life along socialist lines. He rushed wherever where it was more difficult and more dangerous in order to be as useful as possible to his people.

In a short period of time, A. G. Golovko traveled from school officer candidate to a prominent leader of the naval forces. At an age of just over 30 he headed the staff of the Northern Fleet, he was successively in command of the Caspian and Amur Naval Flotillas and in 1940, he was appointed to the post of commander of the Northern Fleet. The author in a small but informative chapter shows how much the young admiral succeeded in doing over this short period of time in strengthening our naval forces in the North. In the energetic, unceasing work of the commander one could feel his perceptiveness and experience gained during the national revolutionary war in Spain.

In the book the main place is taken up with a description of the exceptionally intense and ebullient combat activity of A. V. Golovko during the years of the Great Patriotic War. Precisely in this period his exceptional abilities and qualities as a major military leader were most fully disclosed. They were apparent with particular force in his leadership of the Northern Fleet.

The author convincingly shows how creative was the approach of A. G. Golovko to working out operations in a maritime theater and to improving naval operations in defending our own sealanes and disrupting the enemy ones as well as providing a dependable cover for the maritime flank of the ground forces. Undoubtedly, as the book clearly shows, the operation of the Northern Fleet, under the code name "West" worked out and implemented under Golovko's leadership was an example of the innovative hand of the admiral. It was a component part of the Petsamo-Kirkenes Strategic Operation which ended with the defeat of the Nazi invaders in the Far North.

The book contains much interesting material disclosing the characteristic traits in the activities of A. G. Golovko as a major military leader. The author describes in detail his ability to rely in his work on a broad range of command and party-political cadres. The admiral had high regard and in taking decisions always considered the opinion of the military council, the fleet staff and the political directorate and made skillful use of the initiative of commanders and political workers. He constantly felt a need to consult with the rank and file soldiers, to be in the thick of the sailors, to keep a finger on the pulse of the morale of the personnel as well as know the needs and requests of the men.

Ensuring the safe escorting of Allied convoys in the operational zone of the Northern Fleet held an important place in the combat activities of the Northern Fleet sailors. From the example of carrying out this task and the relationships with the Allies naval missions, the author shows that during the exceptionally difficult period of fighting Nazi aggression, A. G. Golovko was a skillful diplomat who consistently and steadily defended the interests of the Soviet state.

The final chapters of the book describe the activities of Adm A. G. Golovko in the postwar period, when he held the high positions of the chief of the Main Staff and was first deputy commander-in-chief of the USSR Navy. The author writes knowledgeably about his contribution to the further organizational development of our naval forces during the age of the scientific and technical revolution and the turning of them into a powerful nuclear missile fleet capable of carrying out the missions inherent to it in any areas of the world ocean.

Written in a popular form, the book is easy and interesting to read. At the same time, it must be pointed out that the author has not described all the aspects of the life and activities of A. G. Golovko. The book would gain if it more clearly showed the efforts of the commander to develop and strengthen the contacts of the fighting Northern Fleet with the workers of the Soviet North and the entire nation during the war years. In our view, the creative activities of A. G. Golovko should have been more profoundly and soundly



brought out in working out specific operations and in taking various decisions.

As a whole, the book will find a positive response among the broadest circle of readers.

COPYRIGHT: "Voyenno-istoricheskiy zhurnal", 1985

10272

CSO: 1801/272

## RECENT WORKS ON WARSAW PACT

Moscow VOYENNO-ISTORICHESKIY ZHURNAL in Russian No 6, Jun 85 (signed to press 28 May 85) pp 88-89

[Article by Candidate of Historical Sciences I. I. Shinkarev published under the rubric "Historiography and Bibliography": "An Unshakable Combat Alliance"]

[Text] Thirty years have passed since the formation of the Warsaw Pact which is a major factor in the struggle to maintain peace in Europe and throughout the world. On 26 April 1985, the higher party and state leaders of the Warsaw Pact countries signed in Warsaw a protocol on extending it for another 20 years. During this jubilee year more and more people throughout the world are turning to the history of the establishment and development of the Warsaw Pact defensive organization. Over the period of its existence the literature devoted to the birth and further development of this unshakable combat alliance of fraternal countries and armies has continued to be supplemented with new publications. Books have been published the authors of which are prominent military leaders, scientists and writers as well as collectives of scientific institutions. Among them are MSUs I. I. Yakubovskiy and V. G. Kulikov,(1) the Chief of Staff of the Joint Armed Forces, Army Gen A. I. Gribkov,(2) and other officers and generals from the Staff of the Joint Armed Forces,(3) and collectives of scientists from the Military History Institute of the USSR Ministry of Defense(4) and other scientific institutions.(5) Several works have been published in co-authorship with military leaders from the Warsaw Pact socialist states.(6) At the same time, they have been published in Polish, Czech and Bulgarian, they have been highly praised by the readers and have received prizes from the Polish, Czechoslovak and Bulgarian ministries of defense.

Of particular interest are the works which analyze the legal bases for the founding of the defensive alliance of the European socialist state. Among these are the collections of documents(7) and the research work of A. S. Bakhov.(8) These books show that the Warsaw Pact was formed in response to the establishing of the aggressive NATO bloc by the imperialists of the United States and other Western countries and aimed against the socialist states, primarily against the USSR. The published documents disclose the legal bases for the formation of the Warsaw Pact and confirm their full conformity to the

goals and principles of the United Nations and to the principles of peaceful coexistence.

Naturally in all the designated works chief attention has been given to the military collaboration of the Warsaw Pact states. They disclose the main principle on which is founded this collaboration, that is, socialist internationalism. It permeates all the activities of the socialist countries in the area of strengthening the defense capability of each of them as well as in the organizational development and combat training of the fraternal armies. Here collective responsibility for strengthening the defenses of the socialist states which are members of the Warsaw Pact and for the defense of the socialist victories of their peoples in no way violates the sovereignty of each of the allied states and does not permit interference into its internal affairs.

The works "Zarozhdeniye narodnykh armiy stran--uchastnits Varshavskogo Dogovora. 1941-1945 gg" [The Birth of the People's Armies of the Warsaw Pact States. 1941-1945](9) and "Stroitelstvo armiy yevropeyskikh stran sotsialisticheskogo sodruzhestva. 1949-1980" [The Organizational Development of the Armies of the European Socialist Commonwealth Countries. 1949-1980](10) are devoted to the organizational development of the armies of the allied countries. These books comprise, as it were, two parts of one investigation, that is, the development path of the armies in the countries comprising presently the Warsaw Pact. The first of them takes up the rise in the course of the fight against German Naziism of the armed forces of the states where victorious socialist and people's democratic revolutions occurred even prior to the formation of the defensive alliance in 1955. It shows the important role of the Soviet Union in providing fraternal aid to the peoples who threw off the yoke of capitalism, in establishing new armed forces for the defense of socialist victories. The second work reflects the development of the fraternal armies basically within the military collaboration of states which joined the Warsaw Pact.

In all the published works great attention is given to disclosing the fundamental areas, forms and methods of military organizational development in the Warsaw Pact countries, including the questions of military-technical and military-scientific collaboration. Joint measures are widely examined in the area of exchanging experience in combat training, in working out and introducing into practice advanced methods for the training of the troops and for the indoctrination of the personnel. The present state and prospects for the further development of the Warsaw Pact are examined in detail. It is pointed out that at present the Warsaw Pact countries have everything necessary for defending themselves against imperialist aggression and for ensuring their security.

The theoretical and practical importance of the designated works is determined by the fact that they contribute to the ideological arming of the military cadres and to the successful carrying out of the tasks confronting them in the area of raising the combat readiness of the Soviet Armed Forces as a dependable link in the entire alliance of fraternal armies. In addition to its cognitive significance this literature is also an effective means in

unmasking the attempts by bourgeois falsifiers of history to distort the role and purpose of the Warsaw Pact and its clearly expressed defensive nature.

#### FOOTNOTES

1. I. I. Yakubovskiy, "Boyevoye sodruzhestvo" [Combat Alliance], Moscow, Voenizdat, 1977; V. G. Kulikov, "Kollektivnaya zashchita sotsializma" [Collective Defense of Socialism], Moscow, Voenizdat, 1982.
2. A. I. Gribkov, "Na strazhe mira i ssotsializma" [On Guard for Peace and Socialism], Moscow, Znaniye, 1984.
3. "Voyevoye sodruzhestvo bratskikh narodov i armii" [Combat Alliance of the Fraternal Peoples and Armies], Moscow, Voenizdat, 1975; "Varshavskiy Dogovor--soyuz vo imya mira i sotsializma" [The Warsaw Pact--An Alliance for the Sake of Peace and Socialism], Moscow, Voenizdat, 1980.
4. "Stroitelstvo armiy yevropeyskikh stran sotsialisticheskogo sodruzhestva. 1949-1980" [Organizational Development of the Armies of the European Socialist Commonwealth Countries. 1949-1980], Moscow, Nauka, 1984.
5. V. F. Samoylenko, "Osnova boyevogo soyuza: internatsionalizm kak faktor oboronnoy moshchi sotsialisticheskogo sodruzhestva" [The Basis of a Combat Union: Internationalism as a Factor in the Defense Might of the Socialist Commonwealth], Moscow, Voenizdat, 1981.
6. "Bratstvo po oruzhiyu" [Fraternity in Arms], "Braterstwo broni," [in Polish], Moscow, Voenizdat, 1975; "Na vechnyye vremena" [For All Times], "Na vecne casy" [in Czech], Moscow, Voenizdat, 1975; "Vekovaya druzhba, boyevoye bratstvo" [Great Friendship, Combat Fraternity], "Vekova druzhba, boyno bratstvo" [in Bulgarian], Moscow, Voenizdat, 1980.
7. "Organizatsiya Varshavskogo Dogovora. 1955-1975. Dokumenty i materialy" [The Warsaw Pact Organization. 1955-1975. Documents and Materials], Moscow, Politizdat, 1975; "Organizatsiya Varshavskogo Dogovora. 1955-1980" [The Warsaw Pact Organization. 1955-1980], Moscow, Politizdat, 1980.
8. A. S. Bakhov, "Organizatsiya Varshavskogo Dogovora (pravovyye aspekty)" [The Warsaw Pact Organization (Legal Aspects)], Moscow, Nauka, 1971.
9. "Zarozhdeniya narodnykh armiy stran--uchastnits Varshavskogo Dogovora. 1941-1949 gg." [The Birth of the People's Armies of the Warsaw Pact States. 1941-1949], Moscow, Nauka, 1975.
10. "Stroitelstvo armiy yevropeyskikh stran sotsialisticheskogo sodruzhestva. 1949-1980" [The Organizational Development of the Armies of the European Socialist Commonwealth Countries. 1949-1980], Moscow, Nauka, 1984.

COPYRIGHT: "Voyenno-istoricheskiy zhurnal", 1985

10272

CSO: 1801/272

- END -