

JPRS-TND-87-014 296104
18 AUGUST 1987

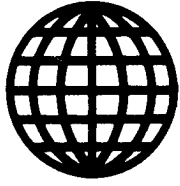

**FOREIGN
BROADCAST
INFORMATION
SERVICE**

JPRS Report

Nuclear Developments

19981109 112

Reproduced From
Best Available Copy

DTIC QUALITY INSPECTED 3

REPRODUCED BY
U.S. DEPARTMENT OF COMMERCE
NATIONAL TECHNICAL
INFORMATION SERVICE
SPRINGFIELD, VA 22161

10
114
A06

NUCLEAR DEVELOPMENTS

CONTENTS

CANADA

Defense White Paper Calls for Nuclear Submarines (Toronto THE GLOBE AND MAIL, 6 Jun 87)	1
Nuclear Submarines, Jeff Sallot Defense Minister Beatty's Analysis, by Perrin Beatty	1 2

CHINA

Measures To Prevent Radioactive Pollution Stiffened (Dong Lisheng; Beijing CHINA DAILY, 3 Jul 87)	4
First-Aid Kit for Nuclear Accidents Developed (Chen Zhiqiang, Zhang Jiajun; Beijing XINHUA Domestic Service, 10 Jul 87)	5

EAST ASIA

AUSTRALIA

Canberra Technique, Waste Disposal Host Proposed (Sydney THE SYDNEY MORNING HERALD, 10 Jun 87)	6
---	---

HONG KONG

Steps in Case of Daya Bay Accident Considered (Peter Robinson; Hong Kong SOUTH CHINA MORNING POST, 30 Jun, 3 Jul 87)	7
--	---

Observatory Nuclear Warning	7
Nuclear Accident Zone Set	7
UK Nuclear Expert Urges Separate Daya Watchdog (Andy Ho; Hong Kong HONGKONG STANDARD, 6 Jul 87)	9
JAPAN	
Cabinet Approves Pact on Nuclear Accidents (Tokyo KYODO, 5 Jun 87)	10
Maeda To Construct Portions of PRC Nuclear Plant (Tokyo KYODO, 15 Jun 87)	11
EAST EUROPE	
YUGOSLAVIA	
Briefs	
Emergency Pumps to USSR	12
Nuclear Power Moratorium Urged	12
LATIN AMERICA	
ARGENTINA	
Alfonsin Opens 'Secret' Nuclear Lab to Sarney (Various sources, 16, 17 Jul 87)	13
CNEA President Explains Work	13
Alfonsin Reaffirms Peaceful Program	13
Sarney on Reciprocal Visit	14
Due Payments Halting Nuclear Plan (Buenos Aires LA PRENSA, 5 Jul 87)	15
CNEA, Economy Ministry Reach Agreement (Buenos Aires NOTICIAS ARGENTINAS, 10 Jul 87)	16
Nuclear Policy, Plan Come Under Criticism (Buenos Aires CLARIN, various dates; Bahia Blanca LA NUEVA PROVINCIA, 14, 15 Jun 87)	17
Call for Clear National Policy	17
Opposition to Nuclear Plan, Alberto Costantini Interview	20
President's Antinuclear Policy	26
Nuclear 'Paralysis', by Martin Olivera	27
Plants Center of Power Struggle, by Daniel Arias	30
CNEA Fights for Its Budget, by Eleonora Gosman	33

Nuclear Plant Workers Demonstrate Over Salaries (Buenos Aires DYN, 16 Jun 87)	35
Labor Conflicts Add to CNEA Difficulties (Various sources, various dates)	36
Plant Shutdowns for Safety Reasons	36
Implications of Shutdowns, by Martin F. Yriart	39
Employee Demands	41
Perez Ferreira Stresses 'Continuity' in CNEA Programs (Buenos Aires LA PRENSA, 23 May 87)	42
Former CNEA Chairman Answers Critics of Sector (Buenos Aires AMBITO FINANCIERO, 25 May 87)	44
Argos vs Candu Decision Conditional to Safeguard Issues (Surrey NUCLEAR ENGINEERING INTERNATIONAL, May 87)	45
Argos Safety Features To Enhance Market Possibilities (A. J. Gonzalez; et al.; Sutton NUCLEAR ENGINEERING INTERNATIONAL, May 87)	47
Province Demands Uranium Royalties (Buenos Aires NOTICIAS ARGENTINAS, 29 Jun 87)	59
U.S. Pressure Seen Behind Perceived Neglect of Nuclear Sector (Bahia Blanca LA NUEVA PROVINCIA, 30 May 87)	60
Nuclear Plant Contract Signed With Iran (Rosental Calmon Alves; Rio de Janeiro JORNAL DO BRASIL, 14 Jun 87)	62
BRAZIL	
Mines Minister Comments on Angra I Leak (Vanessa Malta; Brasilia Domestic Service, 30 Jun 87)	64
Scientists Urge Peaceful Use of Nuclear Energy (Madrid EFE, 10 Jul 87)	65
Westinghouse Sued Over Nuclear Plant Failures (Rio de Janeiro O GLOBO, 18 Jul 87)	66
Briefs	
Radioactive Leak Detected	67
PERU	
Puno Uranium Reserves	68

NEAR EAST & SOUTH ASIA

EGYPT

Consultative Council Discusses Nuclear Energy
(Cairo MENA, 28, 29 Jun 87) 69

Better Training Urged 69
Council Endorses Report 70

Briefs

Nuclear Fuel Factory Completed; Reactor Planned 71

INDIA

Writer Argues Against Import of Nuclear Technology
(Brahma Chellaney; Calcutta THE STATESMAN, 5, 6 Jul 87) 72

U.S. Seeks Cooperation in Blocking Indian Missiles
(J. N. Parimoo; Bombay THE TIMES OF INDIA, 23 Apr 87) 75

Briefs

Atomic Energy Board 77

PAKISTAN

Briefs

Yaqub Khan on Nuclear-Free Zone 78

SOVIET UNION

USSR Cites UK Source on Progress of Pakistan's Nuclear Program
(A. Ostalskiy; Moscow IZVESTIYA, 15 Jul 87) 79

Convention on Physical Safe-Keeping of Nuclear Materials
(Moscow VEDOMOSTI VERKHOVNOGO SOVETA SOYUZA SOVETSKIKH
SOTSIALISTICHESKIKH RESPUBLIK, No 18, 6 May 87) 80

WEST EUROPE

BELGIUM

Mol Nuclear Energy Center Involved in Pakistani Atomic Bomb
(Michel Balthasart; Brussels LE VIF/L'EXPRESS, 24-30 Apr 87) 92

FINLAND

Search for Nuclear Waste Rock-Burial Site Begins
(Helsinki HELSINGIN SANOMAT, 9 Apr 87) 99

FRANCE

Briefs

Nuclear Plant Sodium Leak	104
Radioactive Leak From Nuclear Plant	104

TURKEY

Tea Growers Told To Keep Harvests Separate (Emin Pazarci; TERCUMAN, 22 Apr 87)	105
---	-----

Briefs

Radiation Checks	107
USSR Purchase of Radioactive Hazelnuts	107

/9986

DEFENSE WHITE PAPER CALLS FOR NUCLEAR SUBMARINES

Nuclear Submarines

Toronto THE GLOBE AND MAIL in English 6 Jun 87 pp A1, A2

[Article by Jeff Sallot]

[Text]

OTTAWA

The Canadian navy should buy nuclear submarines that would be able to use "ultimate coercive force" in the Arctic if Canadian sovereignty is challenged, the federal Government said yesterday in its Defence White Paper.

But when pressed to explain specifically what Canada might do if uninvited U.S. submarines were ever found in the Northwest Passage, Defence Minister Perrin Beatty said the revamped Canadian navy would simply collect evidence.

The glossy 89-page illustrated policy book says that "to exercise effective control, there must be a capability to respond with force against incursions."

The white paper announced plans to buy 10 to 12 nuclear-powered submarines capable of navigating under ice in the Arctic. The submarine program would cost at least \$7-billion during the next 20 years, officials say.

Despite the tough language in his policy paper, Mr. Beatty said that Canada would never torpedo an intruding ship from a friendly country, such as the United States, even if the foreign vessel refused to leave waters Canada claims for itself.

Instead, the new submarine fleet would track the intruder to collect

evidence of the intrusion to take to the World Court, Mr. Beatty told reporters.

The long-awaited white paper, first promised by the Conservatives during the 1981 election campaign, calls for total defence spending in excess of \$183-billion during the next 15 years, including the purchase of new hardware. Mr. Beatty would not deny unofficial calculations that the final costs might be more than \$200-billion.

Current defence spending is about \$10-billion a year, and the Tories renewed a promise yesterday to increase annual budgets by 2 per cent or more on top of inflation adjustments.

The white paper also calls for new tanks, helicopters, long-range patrol aircraft, anti-aircraft guns, frigates, radar, satellite surveillance systems, and an increase in the size of the reserves from the current 50,000 to 90,000.

All of this is supposed to happen in the next 15 to 20 years. But the Cabinet, which also wants to bring down the federal deficit while initiating a national child-care program, has given itself a way to put on the brakes if defence spending estimates get out of hand.

The defence capital spending program will have to be reviewed

each fall by the full Cabinet, the white paper says.

As anticipated, the white paper also drops Canada's commitment to send an army brigade and two fighter aircraft squadrons to Norway in times of crisis. Instead, the planes and soldiers would be sent to West Germany, where Canada already has about 7,000 troops stationed permanently.

The United States and some of Canada's European allies within the North Atlantic Treaty Organization had hoped Ottawa might increase substantially the number of troops permanently stationed in Europe, but in fact the white paper anticipates an increase of only 200 or so.

The white paper says Canada is unlikely to be invaded, but the major military threat of Soviet nuclear attack still remains.

The analysis of the military threat in this white paper is similar to that in the last defence white paper, produced 16 years ago by a Liberal government.

The current document leaves open the possibility that Canada might become involved in the controversial U.S. Star Wars program of ballistic missile defences.

Future decisions on Canada's role, if any, in North American continental defences against ballistic

missiles would depend on progress in research into the problem, the white paper says.

Mr. Beatty later qualified this by saying Canada's role would also depend on what happens in the field of arms control between the two superpowers.

Canada would not become involved in any Star Wars program that violated the existing Anti-Ballistic Missile Treaty, he said.

The most controversial part of the white paper will be the submarine program, which opposition Liberals and New Democrats have condemned as an expensive folly.

NDP defence critic Derek Blackburn said Mr. Beatty has a "mindless lust for nuclear submarines." He said he thinks the new Canadian subs would be used to help the United States with its emerging strategy

for attacking Soviet submarines in their northern home ports.

Liberal defence critic Douglas Frith said the federal Government will be wasting money on the subs that should be spent on other defence modernization programs instead.

Undersea sensors; increased air patrols and surface ships are more effective ways of protecting sovereignty in the North, Mr. Frith said.

Despite Canada's sovereignty claims, the U.S. Coast Guard icebreaker Polar Sea has sailed through the Northwest Passage. Even though there was a public outcry in Canada about the voyage, the United States has not altered its position that the passage is an international waterway.

In the event of a dispute with the United States over sovereignty in the Northwest Passage, Mr. Beatty

said, Canada is willing to submit its case to the World Court at the Hague. The United States is not. Washington will not recognize the court's jurisdiction.

What happens then? Mr. Beatty dismissed the question as hypothetical. "We expect friends and allies to respect Canada's rights."

A few moments later, though, Mr. Beatty said the primary role for the new sub fleet will not be in the Arctic, but rather to patrol the east and west coasts. The Government seems to be trying to have it both ways by playing on Canadian concerns about sovereignty to sell the submarine program to the public, when in fact the submarine fleet will really be used to assist the U.S. Navy in the North Atlantic, said John Lamb, the director of the Canadian Centre for Arms Control and Disarmament.

Defense Minister Beatty's Analysis

Toronto THE GLOVE AND MAIL in English 6 Jun 87 pp D1, D2

[Article by Perrin Beatty]

[Text]



AS THE turn of the century approaches, long-term strategic and economic trends have highlighted the need for a three-ocean capability for Canada. While the Atlantic remains the essential link between the two continents in the North Atlantic Treaty Organization, the Pacific and Arctic are assuming greater strategic importance. The development of a capability to meet emerging maritime challenges in the three oceans that border Canada is one of the challenges faced by the Defence White Paper.

These emerging needs are a crucial factor to our decisions in acquiring major new equipment systems. Ships or submarines approved now, for example, will be-

come operational in the mid-90s and remain in service beyond 2025.

The function of maritime forces is to secure control of vital sea areas. Sea control confers abilities to move supplies and equipment across the oceans and to defend from an enemy's hostile approaches to our shores. Canadian naval forces must be able to respond to challenges in our own waters as well as to contribute to the collective maritime strength of the Western alliance.

In order to fulfil Canadian maritime tasks, no single system — aircraft, ships or submarines — alone can satisfy all requirements. A balanced force is essential so that the capabilities of each component complement the others.

In the past, the composition of our navy favored surface forces and focused on Atlantic requirements. Renewal of the surface fleet is under way. The next major step is

replacing our aging and small submarine force. Modern submarines are the most cost-effective means of dealing with projected threats in the North Atlantic and the vast areas of the Northeast Pacific. It is clear that they should receive greater emphasis in the over-all fleet mix. Ice-capable submarines will provide a new three-ocean capability. When added to existing Canadian naval forces, modern submarines will multiply our capabilities, greatly enhancing over-all maritime effectiveness.

In peacetime, submarines are essential because of their effectiveness in underwater surveillance and control, making them a powerful addition to our national capabilities and to our contributions to allied deterrent strength in the Atlantic and Pacific. In wartime, Canadian submarines would provide defence in depth. In the North Atlantic and North Pacific they would be used to prevent hostile submarines from attacking vital sea lines of communication or allied surface forces. They could also operate against missile-firing submarines that threatened North America. As well, ice-capable submarines could intercept hostile submarines in the Canadian Arctic.

A nuclear-propelled submarine is operationally three times as fast as a diesel-electric submarine, because of its ability to sustain submerged speed and unlimited endurance. This allows it to shift its operating area far more rapidly than diesel-electric submarines or surface warships, so that it can readily contribute to sea control where and when needed. Speed is also important tactically in closing on or evading an opponent. Diesel-electric submarines are capable of high submerged speeds only for very short periods — an hour to an hour and a half. For Canadian maritime roles, an ability to operate at sustained high speed is crucial. With three oceans to patrol along the world's longest coastline, the strategic importance of being able to position a small submarine force rapidly is an undisputed advantage in peace or war.

The other major disadvantage faced by a diesel-electric submarine is that it must expose its mast to recharge its batteries, about once a day. That precludes operating freely under the ice.

Older-generation nuclear propulsion systems were noisy, particularly at high speeds; however, technological progress has resulted in nuclear systems as quiet as modern electric propulsion plants.

To deter military intrusions effectively requires being able to detect an intruder and being able to react. In peacetime, a submarine can detect and track intruders and advertise its presence, if desired. The use of active sonar is a clear indication to an intruder that he has been detected, and is the underwater equivalent of a "shot across the bow." The mere threat of a nuclear-powered submarine in an area inhibits an opponent and acts as a powerful deterrent. By contrast, underwater

listening devices alone would provide only a partial solution and would be analogous to building air surveillance radars but not acquiring interceptor aircraft.

The relative cost of nuclear propulsion for submarines has declined over the past two decades. Designs suitable for Canadian roles are available at roughly the same price as modern frigates or 1.6 times that of diesel-electric submarines. As well, delivery schedules of new submarines will distribute their costs into the next century.

Rigorous safety standards followed by other Western navies in building and operating nuclear submarines have ensured nuclear-accident-free operation. The U.S. Navy, for example, has used nuclear propulsion for 34 years and accumulated 3,000 reactor years of operation without a nuclear accident. The Canadian program will draw on Western experience and the domestic nuclear safety expertise of the Atomic Energy Control Board, which is second to none.

Canada has consistently worked to prevent the spread of nuclear weapons. Using nuclear propulsion for conventionally armed submarines is compatible with our international position on the non-proliferation of nuclear weapons and technology. Canadian nuclear-propelled submarines will be armed only with conventional weapons, and will represent a dramatic strengthening of our conventional defence capabilities.

Discussion of SSNs (hunter-killer submarines, in naval parlance) for Canada has focused narrowly on Arctic applications. The point is that we must ensure the capability to defend our shoreline in all three oceans. We cannot abandon our Arctic waters to the submarines of other nations, in peacetime or times of war.

Arctic minefields have been suggested. Mines are extremely blunt instruments allowing for little flexibility and discretion. Also, they would present formidable technological and legal problems and represent an investment that would not have any useful application elsewhere. Such minefields would be considerably less cost-effective or flexible than submarines. In fact, under-ice minelaying and minesweeping capabilities and mines suited for channels covered with ice for all or part of the year would have to be developed virtually from scratch. This would require a very significant investment yet would offer only limited advantages.

In looking to the turn of the century and well beyond, nuclear-powered submarines are clearly the best choice for Canada in response to evolving long-term strategic trends. Such submarines would complement surface ships and maritime aircraft and are the most cost-effective means of achieving an effective operating capability in the three oceans that border Canada. They represent an exciting technological opportunity to enable Canada to meet the maritime challenge of the 21st century.

/9274

CSO, 5120/11

MEASURES TO PREVENT RADIOACTIVE POLLUTION STIFFENED

HK030624 Beijing CHINA DAILY in English 3 Jul 87 p 1

[Article by staff reporter Dong Lisheng]

[Text] China has acted to restrict radioisotope wastes from polluting the environment, a State Environmental Protection Bureau official told CHINA DAILY yesterday.

About 2,000 work units nationwide use artificial radioisotopes. They were first applied to industry, agriculture, medicine, and scientific research in the 1950s, said Luo Guozhen, head of the bureau's radioactive [materials] department.

Radioisotopes produce radioactive pollutants and waste, which amount to 200 to 300 cubic producing the wastes are mainly in urban cities.

He said no administration was in charge of controlling these waste for many years. Units using radioisotopes did not have sound regulations. As a result, accidents happened that polluted the environment and caused injury and death. Luo declined to provide details of these accidents.

Since the early 1980s, the bureau, now in charge of controlling the wastes, has done a lot to solve problems, he said.

In 1983, the bureau conducted a survey in 12 provinces and municipalities on radioactive pollution and control. It then issued a regulation to have warehouses built to store the waste.

Last year, 23 provinces, municipalities and autonomous regions began to build warehouses. Four are finished and this year another six will be put into use.

"The State planning administrations supported these projects and allocated money, although State finances have been under pressure in recent years," Luo said.

The warehouses are either underground, partly underground or above ground. They can each store 100 cubic metres of waste and be used for 20 to 30 years. One warehouse for each city is enough to control the situation, Luo said.

"The bureau will ensure safety regulations are strictly observed at the warehouses," he said.

CHINA

FIRST-AID KIT FOR NUCLEAR ACCIDENTS DEVELOPED

OW102325 Beijing XINHUA Domestic Service in Chinese 0543 GMT 10 Jul 87

[By reporter Chen Zhiqiang and correspondent Zhang Jiajun]

[Text] Beijing, 10 Jul (XINHUA)--China has developed a first-aid kit to give early medical treatment for radiation injuries and a health-protection vehicle to cope with nuclear accidents. This makes it possible to give the injured on-the-spot first-aid treatment in case of a nuclear radiation accident.

Nuclear radiation accidents are those unusual events in which a radioactive energy source gets out of control, raising the radiation level at the work place and environment with direct or indirect harmful effects on people's lives, health, and property. With the development of strategic weapons and the progress made in the peaceful use of nuclear energy, emergency treatment in case of nuclear radiation accident is drawing increasing attention. The International Atomic Energy Agency and nuclear energy organizations of various countries have all formulated emergency treatment plans to cope with radiation accidents. As well as being prepared for such an accident, China has also paid great attention to the work of nuclear safety and radiation protection.

In treating injuries caused by nuclear radiation accidents, early medical treatment is crucial for subsequent effective treatment of the aftermath following irradiation. The newly developed first-aid kit for early medical treatment of nuclear radiation injuries can be carried either by hand or in a vehicle. Used in combination with an ordinary first-aid kit, it can meet the needs of giving emergency treatment either to oneself or to others on-the-spot of a radiation accident. It is an ideal protective facility for nuclear energy production shops, rocket launching sites, and nuclear power plants.

The health-protection sampling and monitoring vehicle for nuclear accidents is equipped with various monitoring instruments and protective equipment. It can be used on-the-spot of an accident to collect, store, and transport samples from the radioactive environment, including soil, air, vegetables, water, and biological samples, which are needed for appraising the radiation effects on human health. The emergency kit in the vehicle can be used for brief medical treatment of radiation injuries. All instruments and equipment installed in the vehicle are made domestically and are characterized by good waterproof and shockproof properties.

/9716

CSO: 5400/4129

CANBERRA TECHNIQUE, WASTE DISPOSAL HOST PROPOSED

Sydney THE SYDNEY MORNING HERALD in English 10 Jun 87 p 7

[Text]

MELBOURNE: A new deep-burial technique proposed by CSIRO scientists promises to enhance Australia's strong credentials as a potential custodian for the safe storage of the world's nuclear wastes.

The CSIRO has described a method of establishing a self-contained "loop" of groundwater to cool buried wastes immobilised in Synroc, the material developed by an Australian scientist, Professor Ted Ringwood, for storing highly radioactive wastes permanently and safely.

The technique, described in the winter edition of CSIRO's magazine *Ecos*, would use heat from the wastes to drive a constant convective current of cool water through the loop, using the same thermosiphon principle employed in solar water heaters.

The article also describes a Swedish technique of encasing wastes immobilised in Synroc or borosilicate glass in copper canisters. In the favourable environment created by the "cool loop", the canisters would last at least a million years.

As a relatively new technology, Synroc has not achieved the momentum of the borosilicate glass storage technology favoured by European nations and the United States, even though its exceptional resistance to heat and chemical leaching makes it a vastly more durable and safer storage medium for N-wastes.

The new underground storage technique, developed by the CSIRO's division of applied geomechanics can only enhance Synroc's candidacy as a storage medium, while emphasising Australia's credentials as the ideal repository for the world's nuclear wastes.

The safe storage of nuclear wastes remains an enormous and intractable problem, even in the most advanced nations. Virtually all nuclear wastes since World War II, whether from weapons projects or nuclear power stations, still await the development of a permanent storage technology.

Among novice nuclear nations such as India and Pakistan, nuclear wastes are stored above ground

where they are vulnerable to terrorist attacks or dispersal by natural disasters or nuclear war.

Even without considering its increasing eminence in storage technology, Australia has impeccable credentials as a safe repository for the world's nuclear wastes.

It has one of the most stable political environments of any nation in the world, and boasts the safest geology of any major land mass.

Western Australia's Archaean Shield, an extensive region of ancient granites, represents the largest and oldest unchanged geological feature in the world — some of its granites are three billion years old and are precisely the type envisaged by the CSIRO for creating its cool storage loops.

The acting chief of the division, Dr Bruce Hobbs, said yesterday that "any good granite" free from jointing, micro-fractures and chemical alteration, and "a long way from people" would be suitable for establishing storage structures.

/9274

CSO: 5100/4312

STEPS IN CASE OF DAYA BAY ACCIDENT CONSIDERED

Observatory Nuclear Warning

Hong Kong SOUTH CHINA MORNING POST in English 30 Jun 87 p 3

[Article by Peter Robinson]

[Excerpt]

NEWS of any increase in radiation levels due to a leak from the Daya Bay nuclear plant would first be given to the Government and then, after verification, to the public, according to the Royal Observatory.

The director of the observatory, Mr Patrick Sham, said this yesterday following a review of the observatory's activities over the past year.

The observatory monitors radiation levels as well as weather conditions and is working with the Economic Services Branch on how best to monitor the Daya Bay plant.

Mr Sham said: "We would first have to verify

that there had been a genuine increase in radiation and tell the Government then the public. We would have to verify that the increase was due to Daya Bay and consider other factors such as wind direction.

"We hope there will be direct contact with Daya Bay by telex or telephone to verify the increase. The Economic Services Branch is at present looking into this as part of the overall plans the Government is looking into for a warning system."

Mr Sham said that radiation figures would be released no matter what was found. Asked if there would be regular reports he questioned whether this would be

necessary and emphasised that the findings had to be verified before being made public.

On the subject of evacuation he said: "British Atomic Energy Institute experts came here and said that Hongkong people would not have to evacuate but take certain precautionary measures such as handling food carefully."

The observatory is presently studying natural radiation levels throughout the territory. Mr Sham explained: "We have only just started measuring background radiation to try and find local variations. This is in preparation for Daya Bay so that we will know the normal background radiation."

Nuclear Accident Zone Set

Hong Kong SOUTH CHINA MORNING POST in English 3 Jul 87 p 3

[Article by Peter Robinson]

[Text]

CONSULTANTS were likely to recommend an evacuation area of up to 16 km from Daya Bay should there be a serious accident at the nuclear plant, said Mr John Wilson, the principal

assistant secretary of Economic Services Branch (special duties).

Mr Wilson, with colleague Mr Ken Woodhouse, recently returned from a nuclear accident drill in the United States. About 70 countries were represented at the drill at the Zion nuclear power station in Illinois which is similar in size to Daya Bay.

China did not send a representative.

Mr Wilson said yesterday the report by the UK's Atomic Energy Authority on emergency plans for the Daya Bay plant was likely to be ready by August and would be published.

He said: "Extreme measures are unlikely to be recommended regarding evacuation. If we had thought there would be a need to evacuate we would have wanted the plant further away."

At the US drill an evacuation zone of 16 km radius of the plant was set up and Mr Wilson envisaged this sort of zone being applied here. Daya Bay is 80 km northeast of Hongkong.

The US experts were reported to have been impressed by an additional safety filter which would be used at Daya Bay. If there was a serious accident in the nuclear container vessel it would be possible to filter off some of the excessive pressure.

The US Zion nuclear plant is similar to Daya Bay's prospective capacity with two 1,000-megawatt units. The exercise was called chiefly to monitor how successful different agencies are in coordinating efforts to cope with a nuclear emergency.

Both the state of Illinois and the neighbouring state of Wisconsin were involved.

Mr Wilson said: "It was all very impressive with lots of practical things learnt and it was useful to see at first hand. My impression was that Hongkong's own facilities to cope with this are already similar to the ones used for this exercise."

/9274
CSO: 5150/0165

UK NUCLEAR EXPERT URGES SEPARATE DAYA WATCHDOG

Hong Kong HONGKONG STANDARD in English 6 Jul 87 p 1

[Article by Andy Ho]

[Text]

A BRITISH expert on nuclear safety has called for an independent advisory body with the right to question government and nuclear industry officials on matters relating to Daya Bay.

Professor Hugh Simpson, a member of the British Advisory Committee on the Safety of Nuclear Installations, told *The Standard* that the committee should be established as soon as possible and comprise about eight public experts on nuclear matters.

The advice comes just a month before the Government is to review a consultancy report on emergency planning for Hongkong in the event of a mishap at the Daya Bay nuclear power plant.

Only Government officials will be involved in drafting the contingency measures, if a Daya Bay advisory panel is not set up before the plans are finalised.

Prof Simpson, who heads Strathclyde University's Thermodynamics and Fluid Mechanics Department, has just completed a week-long visit here as an external examiner of the Hongkong Polytechnic.

The visiting professor said the proposed nuclear safety body could be modelled on the British nuclear safety advisory committee.

The British group meets about four times a year and publishes a report every one or two years.

"None of our members are civil servants. All members are invited by the Minister of Energy. Most of us are academics who have worked in the industry or trade unionists associated with the industry," Prof Simpson said.

He said the 12-member British nuclear advisory body included experts such as medical doctors, civil engineers and insurance professionals.

All members serve on the committee in an independent and honorary capacity. But the committee is backed by the staff of other official establishments such as the Central Electricity Generating Board and the Nuclear Installations Inspectorate.

The proposed committee, Prof Simpson said, could set up research groups and invite experts from outside to make pre-

sentations on specific topics whenever necessary.

He said he understood the complications arising from the Daya Bay plant's location on Chinese soil, and underlined the need for close cooperation with Chinese officials.

He proposed that experts on food-chains, radiological protection and other specialities be invited to sit on the advisory body.

He cautioned, however, that anti-nuclear lobbyists should not be included in the proposed committee.

"The committee should be prepared to take evidence and submissions from the groups, but should comprise independent and impartial persons," he stressed.

"I don't want it ending up as a pressure group. It is intended to be an expert group asking questions and getting answers on the industry," Prof Simpson said.

Legislative councillors came up with a similar proposal last September after visiting nuclear facilities abroad. Until now the Government has not committed itself on such a committee.

/9274

CSO: 5150/0166

JAPAN

EAST ASIA

CABINET APPROVES PACT ON NUCLEAR ACCIDENTS

OW050451 Tokyo KYODO in English 0415 GMT 5 Jun 87

[Text] Tokyo, June 5 KYODO -- The cabinet gave official approval Friday to two international treaties on major accidents involving nuclear power plants.

One of the two pacts obliges the signatory country to give early notification to the International Atomic Energy Agency (IAEA) of any serious accident at its nuclear power facilities and the other urges other signatories to give assistance to deal with such emergencies.

Japan signed the international conventions in March. They were adopted at the IAE special assembly in September last year in the wake of the accident at the Chernobyl Nuclear Power Station in the Soviet Union the previous April.

Following formal cabinet approval Friday, the treaties will go into effect in 30 days. Japan is the 12th signatory of the first treaty and the eighth nation to sign the second.

/9738

CSO: 5160/045

JAPAN

EAST ASIA

MAEDA TO CONSTRUCT PORTIONS OF PRC NUCLEAR PLANT

OW150655 Tokyo KYODO in English 0623 GMT 15 Jun 87

[Text] Tokyo, June 15 KYODO -- Maeda Construction Co., Ltd. announced Monday the signing of a contract last week with Chinese authorities to build auxiliary facilities for the country's first major nuclear power plant. The power station with two pressurized light water reactors and a total of 1.8 kilowatts of generating power, is to be located in Shenzhen, Guangdong Province. The plant, which is expected to be on line by November 1992, will supply about 70 percent of its generated electric power to Hong Kong. The contract signed on June 11 includes construction of buildings for the reactors, transformers and a drainage system, Maeda said. The construction company has already begun work on the project, Maeda said.

/9738

CSO: 5160/047

BRIEFS

EMERGENCY PUMPS TO USSR--Nis, 1 Jun (TANJUG)--The Jastrebac Pump Works, which is part of the Nis Mechanical Engineering Industry, delivered two more emergency pumps for nuclear power stations to its partner in the Soviet Union today. This year the workers and experts of the Nis works, developing the ultimate technology in this sphere, will deliver 30 pumping installations for nuclear power stations to foreign partners. The manufacture of emergency pumps for nuclear power stations is a long-term agreement with customers from the Soviet Union. [Text] [Belgrade TANJUG Domestic Service in Serbo-Croatian 0722 GMT 1 Jun 87 LD] /8309

NUCLEAR POWER MORATORIUM URGED--Belgrade, 10 Jun (TANJUG)--The Yugoslav Socialist Youth Federation Conference decided today to call on the SFRY Assembly to pass a law on a moratorium on the building of new nuclear power stations. This decision was adopted despite assurances from FEC member Andrej Ocvirk that in Yugoslavia's long-term program for energy development, adopted recently by the FEC, there are no plans for the construction of new nuclear power stations up to the year 2000 and that they may not be built after that either. Replying to a list of questions sent to the Federal Government by a working party of the conference, Ocvirk said energy development will be directed toward better and more rational utilization of existing sources, but he clearly did not succeed in convincing the youth delegation that there is nothing happening behind the backs of the public in the nuclear program. [Text] [Belgrade TANJUG Domestic Service in Serbo-Croatian 1212 GMT 10 Jun 87] /8309

CSO: 5100/3020

ARGENTINA

LATIN AMERICA

ALFONSIN OPENS 'SECRET' NUCLEAR LAB TO SARNEY

CNEA President Explains Work

PY170156 Buenos Aires TELAM in Spanish 0044 GMT 17 Jul 87

[Excerpts] San Carlos de Bariloche, 16 Jul (TELAM)--Emma Perez Ferreira, president of the National Commission for Atomic Energy (CNEA), this afternoon told Brazilian President Jose Sarney that his presence in the secret nuclear laboratory of INVAP (Applied Research) will serve to disprove malicious reports spread abroad about the use of nuclear energy.

Perez Ferreira guided Presidents Jose Sarney and Raul Alfonsin inside the laboratory to explain the work being conducted there. The INVAP laboratory is located in Pilcaniyeu, 60 km from San Carlos de Bariloche. She added that Sarney's visit will do away with any uncertainty or doubt about our two countries.

Television cameras were not allowed inside and pictures of the area were prohibited. Alfonsin and Sarney posed for cameramen and photographers at the entrance of the building.

Once inside the building Sarney and Alfonsin were briefed on how INVAP operates by CNEA President Perez Ferreira and INVAP Director Baroto. He gave a superficial explanation on how INVAP operates, without getting into scientific details that are considered secret.

President Sarney was very interested and on several occasions asked questions about the equipment shown by the technicians and engineers.

Alfonsin's and Sarney's visit to Pilcaniyeu is the first made by a national and foreign chief of state to a nuclear element processing plant.

Alfonsin Reaffirms Peaceful Program

PY170306 Buenos Aires NOTICIAS ARGENTINAS in Spanish 2330 GMT 16 Jul 87

[Excerpts] San Carlos de Bariloche, 16 Jul (NA)--President Raul Alfonsin today affirmed to his Brazilian counterpart Jose Sarney the Argentine decision

to offer all necessary safeguards to demonstrate that the objectives of the Argentine nuclear program "are absolutely peaceful."

This was revealed here this afternoon by a source of the Argentine delegation that is accompanying President Alfonsin, after a 40-minute visit the two presidents made to the secret uranium enrichment plant located in Pilcaniyeu, a desolate area 60 km east of San Carlos de Bariloche.

The sources did not discard the possibility that during the talks held this afternoon Alfonsin and Sarney could have reached some progress toward the possibility that Argentina--taking into account the advanced technology it has in Pilcaniyeu--could in the future enrich uranium for Brazilian industry.

The Argentine delegation source added that Alfonsin and Sarney held a first working meeting on the plane that took them to Bariloche, during which they discussed almost exclusively aspects of the political situation in Brazil and Argentina.

Asked whether Argentina will maintain a system of mutually exchanging information with Brazil in the nuclear field, Alfonsin said Sarney's visit to the uranium enrichment plant marks the beginning of increasingly fruitful talks, which could lead to various resolutions. In this regard, Sarney said his visit to Argentina marks the first time a head of state has invited another head of state to visit a uranium enrichment plant, which is a secret facility. Sarney made it clear that this gesture shows President Raul Alfonsin's statesmanship, vision of the present, and vision of the future. I hope that on his next visit to Brazil I will have a chance to reciprocate Alfonsin's gesture by inviting him to our [uranium enrichment] plant, Sarney added. Sarney said: Our two nations are entirely dedicated to the peaceful use of nuclear energy and to achieving access to advanced technology through our scientists and technicians.

Sarney on Reciprocal Visit

PY161810 Buenos Aires Domestic Service in Spanish 1600 GMT 16 Jul 87

[Excerpts] Argentine President Raul Alfonsin and Brazilian President Jose Sarney at noon today arrived in Bariloche, where they will hold a second working meeting to discuss the integration process.

Before leaving for Bariloche, Alfonsin said in Buenos Aires that among the agreements signed with Brazil, the most important is the one establishing a trade currency. He also stated that Argentina is carrying out activities in the nuclear field for peaceful purposes.

Brazilian President Jose Sarney said that the Brazilian-Argentine nuclear agreement will have a great impact internationally because the two countries are showing they have peaceful intentions and the development of the nuclear field is intended only for peaceful purposes. Sarney added: I see that the agreements signed 1 year ago with Argentina are being fulfilled, and I believe Argentina and Brazil have strengthened their bilateral ties.

Before boarding the plane for Bariloche, Sarney said: I have loved Argentina and strengthened bilateral relations more than any other Brazilian president.

/9599

CSO: 5100/2123

ARGENTINA

LATIN AMERICA

DUE PAYMENTS HALTING NUCLEAR PLAN

PY061910 Buenos Aires LA PRENSA in Spanish 5 Jul 87 p 5

[Text] National Commission for Atomic Energy (CNEA) President Emma Perez Ferreira has said the continuation of the Argentine nuclear program is contingent upon reaching agreement between the contractors and the state.

The CNEA president said the businessmen who have contracts with the state in the nuclear field met last Tuesday with Finance Secretary Mario Brodersohn. The businessmen disagreed with the overtures made concerning payments due by the state. The CNEA president, speaking to the newspaper LA RAZON, said the businessmen stated that the conditions "will not permit them to continue with the work."

The continuation of the nuclear program was the point of friction that led to the resignation of former CNEA head Alberto Constantini because the Finance Secretariat did not release the funds to pay the contractors.

In April 1987 a meeting was held with the contractors, and they were offered a payment schedule, which they did not accept. Another payment schedule, which was offered last Tuesday, did not meet their expectations either, according to Perez Ferreira. The CNEA is mainly concerned over the continuation of work on the third nuclear power plant (Atucha II), the heavy water plant in Arroyito, and the maintenance of the research centers.

/9738

CSO: 5100/2115

ARGENTINA

LATIN AMERICA

CNEA, ECONOMY MINISTRY REACH AGREEMENT

PY110325 Buenos Aires NOTICIAS ARGENTINAS in Spanish 2038 GMT 10 Jul 87

[Text] Buenos Aires, 10 Jul (NA)--It has been officially reported that the National Commission for Atomic Energy (CNEA) and the Economy Ministry today agreed on several basic guidelines, financing, and the supply of funds for this years budget, which will allow the agency to "prepare a long-term schedule for the implementation of current projects."

The Economy Ministry and the CNEA issued a joint press release stating that they also agreed on "a basic outline for the 1988 budget," and that this agreement will be explained in a memorandum to be released soon.

The press release added that after several meetings between representatives of the CNEA and the Economy Ministry to analyze "the nation's financial possibilities within the current economic situation and in view of the goals of the national energy program," several conclusions were reached.

Among other things, the CNEA promised to "increase austerity measures and make sure that allocated funds are used rationally by making a critical assessment of its programs and maintaining its objective of technological independence in the nuclear field."

The communique emphasized that "the projects will continue in accordance with a timetable that will be reconciled with the estimates of the national energy plan prepared by the Energy Secretariat."

It added: "Negotiation with suppliers will continue in order to reach agreement on financing and terms of payment, which will allow the CNEA to participate in ongoing projects that are within the possibilities of the treasury."

Among other projects, the CNEA is building the Atucha II nuclear plant, the Arroyito heavy water plant and the Tandara particle accelerator.

/9599

CSO: 5100/2123

NUCLEAR POLICY, PLAN COME UNDER CRITICISM

Call for Clear National Policy

Buenos Aires CLARIN in Spanish 9 Jun 87 p 4

[Article prepared by the Argentine Association of Nuclear Technology on the occasion of the 31 May anniversary of the founding of the National Atomic Energy Commission]

[Text] For the 37 years since its founding, the CNEA [National Atomic Energy Commission] has been working to increase our national independence. Both its research-oriented programs and those that have been developing an advanced nuclear technology, applied and transferred to various fields of the nation's industrial activity, have helped to place Argentina in a clearly favorable position.

If a public opinion poll were to be conducted among the population, it might come to the overwhelming conclusion that the issue of nuclear energy is almost wholly associated with nuclear power plants. While this field has been the target of major economic and human efforts designed to resolve our energy demand problems, and for several months this year our nuclear power plants have provided 16.5 percent of the electricity used in Argentina, this is still only one part of the nuclear sector's activity.

A retrospective view would show that 20 January 1958, the date when the RA-1 was put into operation, was a key moment in this process. The RA-1 was the first experimental reactor built in Argentina; it was based on a North American design but did incorporate some major Argentine innovations. Later, in 1968, the RA-3 was put into service. This reactor was totally designed and built in Argentina. It produces radioisotopes that are used in extremely diverse fields, such as food supplies, agriculture, veterinary medicine, medicine, industry, etc. In every case the objective was--and continues to be--to improve our people's quality of life. Nuclear energy plays a vital role in sterilizing biomedical products, in improving agricultural and livestock production, in eradicating disease, and in food preservation.

Argentina's nuclear medicine--thanks to the CNEA's strong commitment to it--has reached an internationally recognized level of excellence in the diagnosis and treatment of disease.

It is impossible to overlook one of the aspects most directly involved in these attainments: that is, the CNEA's human resources.

Needs for the Future

How to resolve the future's increasing energy demands and how to deal with the decline in the world's available resources after the year 2000: these are two questions which have generated a great deal of thought in recent decades. The fact is that, despite the major efforts that have been invested in research and development of new energy sources, at the present time nuclear energy is the only technology that can provide a strong and commercially competitive response. The more rationally we use our current resources of labor, capital and knowledge, the greater will be our ability to deal successfully with future energy requirements for both the people and our industrial development.

The problem of safety in nuclear facilities is of concern not only to all of the world's population, but above all to experts in this field. New analyses, taking all circumstances into account, have reconfirmed the reliability of nuclear facilities, which remain a valid option for dealing with the future's inevitable energy requirements, needed to improve the quality of life.

There is no question that if we do not seriously accept responsibility for providing for future generations the energy they will need in order to live decently, the problems can not be resolved, and it will become impossible to improvise developments of such magnitude.

Letter to President Alfonsín

Because of the current crisis affecting our national nuclear activity, the AATN [Argentine Association of Nuclear Technology] sent a letter to President Alfonsín dated 22 April 1987. In this letter the AATN expressed its profound concern about the current state of affairs, which involves the continuity of nuclear activities and the survival of nuclear-related companies, since "some of them have had 120-day delays in project construction certificates."

The letter also mentioned some of the effects that might occur if these problems are not resolved, such as halting work on these projects in the short term, weakening the level of technological development achieved by both the government and the private sector, the discouragement and even the possible loss of jobs and exodus of professionals and technicians, and the risk of an unplanned contraction of the work done by companies engaged in Argentina's nuclear program.

Finally, the letter requested President Alfonsin's support for continuing the interaction undertaken between the private sector and the state, with the international ramifications represented by integration with Brazil, which was initiated by the Joint Foz do Iguazu Declaration of December 1985.

The Risks of Lack of Continuity

The AATN, aware as is our national government of the need to modernize Argentina, understands that scientific-technological development is the only way to ensure the population's greater future wellbeing, by means of allowing Argentina to join the world of countries that are competing for supremacy in high-tech fields.

There can be no doubt that one of these fields is nuclear technology which, as has been said before, stimulates a nation's scientific and technological development in the most diverse areas.

The Argentine nuclear community is composed not only of the CNEA and its peripheral enterprises, but also of a complex of private companies.

Government Decisions

Nuclear activity as a whole is going through a serious crisis because of our present economic problems. Economic restrictions and low salaries in the government sector are playing a fundamental role in this crisis, endangering the development we have reached, the benefits of the investments we have made, and the continuation of our highly skilled professional and technical staffs. It has taken major investments and decades of continued efforts to bring all these together.

It is obvious that the nuclear sector's survival and growth will depend on government decisions. Such decisions should be based not only on our country's general situation at the present time, but also on our future strategic needs, fundamentally on our energy needs.

Given this context, it does not seem absurd to talk of a fourth nuclear power plant in order to sustain the level of technological development we have reached.

Using Our Own Technology

Because of the decision to use natural uranium in Argentina's nuclear power plants, we have been able to fully master the fuel cycle, starting with mining of the uranium and production of concentrates, up to and including the fabrication of the fuel elements, whose zircaloy shielding is produced by the CNEA. And the CNEA is now developing the uranium enrichment process in its Pilcaniyeu plant.

These and other undertakings are part of our heritage. Their vital importance lies in the independence they give Argentina in nuclear activities. It isn't necessary to go on and on, using one argument after another, to show how much that independence has cost Argentina.

In this context, the need to establish a clear national policy, one which will guide the planning of our nuclear activities, is evident.

Opposition to Nuclear Plan

Bahia Blanca LA NUEVA PROVINCIA in Spanish 14 Jun 87 pp 1, 4

[Interview with Alberto Costantini, former CNEA director, by Hugo Ezequiel Lezama]

[Text] He is a white-haired, mild mannered grandfather of nine grandchildren, with drooping eyelids, stately movements, a deep voice, one which on some issues can become an extremely harsh and vibrant machine.

Alberto Rafael Costantini (that's right, "Costantini," no "n" after the "o", despite the fact that newspapers and books often misspell his name) is 72 years old. He was born on 2 April 1915, so he is a formidable Aries. He is a hydraulic and civil engineer; his studies were done at the University of La Plata. He has held extremely important jobs: dean of the faculty of engineering, naturally a regular university professor in several disciplines; he was twice secretary of state; he has served as minister of public works and had held many other positions until 1984, the year when he accepted the chairmanship of the CNEA. Extremely courteous and patient, he answers questions with meticulous care, but he never smiled, except when at one point he spoke of his reputation for having a poor character, and a roguish smile broke through his grave demeanor. The reader will see that he does not remain silent, he is not evasive, and he does not use subterfuges. Above all else, he is very intelligent and the range of his interests is extraordinarily broad and up-to-date. Engineer Costantini--I have no doubt about this--is a young man in the vanguard.

Question: Engineer, why did you resign from the CNEA?

Answer: Because after a number of fruitless efforts I finally came to understand that I would never be able to get the nuclear plan going again.

Question: You didn't talk with the president about this?

Answer: I talked with the president, discussing the problem that was coming up, in January, February and March. In April, when I had taken a more definite position, I told the president that under these circumstances--without

resources of any sort--I could no longer continue in that position. In every instance, the president assured me that this was a temporary situation, and that things were going to be worked out.

Question: But they were not worked out?

Answer: No. When after three meetings with the president I found that nothing was changing, I decided to resign. When I resigned, the president did not meet with me; he only instructed Becerra [secretary general of the presidency] to ask me to be patient, to wait for 2 or 3 days. I agreed to this on the condition that the economic problems which had arisen be resolved, so for that reason I wanted to meet with Alfonsin, Sourrouille and Brodersohn. They agreed, but because Sourrouille and Brodersohn were in the United States, I was told I would have to wait for them to return.

Question: Well, what happened when that meeting was held; what explanation did they give you?

Answer: That meeting never took place.

Question: Why not?

Answer: I was never given an appointment for that meeting, and I never met with the president again. So on 8 May, 30 days after submitting my resignation, I told Becerra that when the president had a minute free, I would be interested in saying goodbye to him. So far I have never had any answer to that request.

Question: Such behavior seems fairly unusual.

Answer: Yes, people do say the radicals don't like to talk very much.

The Power of the Merchants

Question: At what rate is work now proceeding on the CNEA's projects?

Answer: At the present time they must all be shut down; the commission has received almost no money for projects this year and when I left a month ago, there were cumulative debts of over 120 million australs. At most, there may be projects involving only maintenance or conservation, which means that they are engaged in unproductive spending, since what isn't spent on doing the work is spent on keeping the project shut down.

Question: Plus the loss of earnings, plus the loss of interest...

Answer: Sure, that doesn't seem an intelligent step for a poor country. Putting the money into unproductive spending doesn't seem the most advisable thing to do.

Question: Engineer, what you are telling us forces us to think about the people who are setting nuclear policy in Argentina.

Answer: Nuclear policy was set by two executive decrees, which date back a number of years, and it has not been changed by the present government authorities. On the contrary, that policy was accepted and ratified by the president of the nation in a speech he gave at the Embalse nuclear power plant on 31 May 1986.

Question: That is not reflected in what is going on.

Answer: What is happening is that the decisions and the funds don't come from the same place. I had proposed to the executive to convert 90 percent of the CNEA into a state enterprise in which all commercial and productive activities of the commission, mining industries, up to and including the production of heavy water, would be incorporated. And on the other side, I also proposed the creation of a productive enterprise to operate nuclear power plants, to which ENACE [Argentine Nuclear Enterprise for Electrical Power Plants] would be added, since it already exists, and it is the architect of our future power plants. The bill left it up to the state to determine nuclear policy, nuclear safety, radiological protection, and naturally management control.

Question: What would happen with those modifications?

Answer: The bill provided a method that would enable us to finance ourselves. The commission would receive a tariff rate at least equivalent to the average of what the unified load circuit now receives. At the present time the CNEA gets 18 cents per kilowatt and Salto Grande, which has lower raw material costs, gets 34 cents. What we were asking is to be given 23 cents. With that difference we could set up a fund to pay for all the operating and subsidiary research costs, leaving the commission virtually self-financed. What I wanted in the end was to detach the CNEA from the treasury.

Question: Then it's the treasury that sets our nuclear policy?

Answer: I have lengthy experience that tells me that every time an activity depends on the treasury, it ends up paralyzed or gets extremely expensive.

Question: Is that happening with the commission?

Answer: The fund I was talking about earlier was specifically designed to avoid such problems, since it would allow the commission to keep working on solid grounds and with real values, and not to build, as we do now, on absolutely unreal values. One example of this is the Atucha II plant, which 10 years ago was contracted for \$1.4 billion; now, because of delays and consequent unproductive costs, it is going to end up costing over \$4 billion. On that basis the country is never going to be able to recover or raise its head again.

Question: Engineer, if the political decision does exist, through a plan that has not been changed, and there is economic feasibility, through the plan you proposed, people might believe that the reason why there is paralysis is that the nuclear plan has enemies inside the government.

Answer: I couldn't say whether there is an enemy, but I will tell you that at the present time there is no acceptance of the nuclear plan inside the national government. For example, Minister Trucco [minister of public works and services] told a foreign businessman that even though the nuclear plan was not within his field of competence, he understood it was to be modified. Moreover, Minister Sourrouille [minister of the economy] and Secretary Brodersohn [secretary of finance], when forced to accept the nuclear plan because of exigencies of the national energy plan, did not react directly but omitted to include the funding necessary for CNEA projects in the 1987 budget, condemning the CNEA to slow agony and total paralysis. Secretary Sommer, at the same meetings, complained that the commission was building grandiose projects, while Undersecretary Carciofi said that the CNEA's budget could not be accepted because they were building a nuclear hospital and, more amazingly, Secretary Canitrot maintained that the nuclear plan would have to be reanalyzed because our country is "broke" and consequently can't be a nuclear power.

The Golden Calf

Question: So it seems there are enemies and they have been fairly well identified...

Answer: Canitrot was concerned that his comments might hurt me, not realizing that in any event they were hurting the country, for when an activity has come to occupy sixth or seventh place in the world, and it is then downgraded to 42nd position, which is where we stand in other fields, that can not be a source of pride.

Question: That is reason for indignation.

Answer: I insist, I don't know whether there are enemies of the nuclear plan in the country, but what I do know is that there are economists who are enemies of the republic's development. These are people who live constantly thinking about the monetary sign, trying out formulas from the developed countries. Classical monetarism is useful for the developed countries which have to control their currency, but for countries like ours, which are underdeveloped, development and not maintaining a permanent dependency on the developed countries are of greater interest than the monetary sign. That is what is so painful about all these events.

Question: So the nuclear plan is not really a target in itself, but rather because it is a factor promoting development.

Answer: I can't be sure if it is the nuclear plan, the economic schemas, or the orders of the industrialized or developed countries about what we should or should not do.

Question: Mr Costantini, there are two things in the nuclear plan that have always bothered the developed countries, and since we are talking about pressures it would be good to mention them. I am referring specifically to our non-ratification of the Treaty of Tlatelolco and our not signing the Non-Proliferation Treaty. What has your position on these two international instruments been?

Answer: I would not ratify Tlatelolco and I would not sign the Nuclear Non-Proliferation Treaty. Both treaties are subjected to the Club of London, an organization that controls the world's nuclear policy, so countries which are already armed can remain armed, and the unarmed countries will have to remain unarmed. That is the philosophy behind both treaties: treating those who do not already have nuclear weapons very harshly. If the treaties were egalitarian, we would be willing to sign them.

Question: In any event, the pressures must make themselves felt...

Answer: There is not a single conversation with U.S. officials in which they don't ask us why we refused to sign Tlatelolco. Nevertheless, the pressures have declined somewhat recently; maybe they have given up because of our position. Still, Argentina can not even buy a computer for the CNEA, since everything that goes to the commission is considered to be used for nuclear development, and as we did not sign the international treaties, the developed countries do not want to sell to us. It is fair to recognize that Germany's position is more flexible; Canada's is somewhat less so, and to some extent, so is France's position. But the general attitude is quite rigid.

Question: That does have a positive and a negative side; it may hold us back, but at the same time it forces us to grow.

Answer: A good part of our nuclear development has come as a consequence of not being able to import North American and European products which they refused to sell us. At one time, we wanted to buy enriched uranium for our research reactors and because no one was willing to sell it to us, we ended up enriching the uranium using Argentine processes. In summary, they have forced us to develop our own Argentine technology by not selling us any of their products.

Question: Engineer, what level has our independence now reached?

Answer: If we now cut back on our nuclear activity, we are going to enter the next century without the power plant engineering capability we will need to act with independence. Then we will be forced to rely absolutely on the developed countries. This has to be made very clear: Argentina has total

independence in nuclear fuel cycle technology, but it does not have absolute mastery in power plant engineering, and if we do not attain that, our entire effort will be in vain. That is the reason why it is so important to continue to work on Atucha II and to build at least one 350-MW plant every 6 years.

There is No Worse Blindness...

Question: Engineer Costantini, did you explain to the government officials all the aspects involved in nuclear development?

Answer: Look, I explained that everywhere I could. The president of Argentina knows my thinking on all this very well; Sourrouille, whom I saw less frequently, told me that he didn't know what the commission was really all about. I just don't know, if he had been talking to me for 2 years and had been transferring funds to me, and still didn't know what the commission was; I don't understand that at all.

Question: But what did he mean, Mr Costantini?

Answer: He said he didn't know if it was a scientific or productive institute or a public division. I answered him that it was all three things at once, because it is scientific, because it is productive, and because at the same time nuclear policy, because of its functions, is a public function. This demonstrates the importance of its financial autonomy, since without it any president or minister can make a decision without sufficient knowledge.

Question: Any minister, engineer?

Answer: Here, unfortunately, the prime minister is always the minister of the economy, and he is the one who handles the nation's policy through economic pressures and the provision and distribution of funds.

Question: So the minister of the economy sets nuclear policy?

Answer: And not only nuclear policy. If we fall into the hands of the economists, we fall into the hands of monetarism, and 50 years ago economists of the most different stripes fell into monetarism.

Question: And that put a stop to development.

Answer: And that put a stop to development.

Question: But what did the president say?

Answer: Once the president told me: "They are working against you in the finance ministry. They were working against me on all sides. And to think that I accepted the job without even being a member of the Radical Party, when I was over 70 years old, and without accepting a salary from the

commission, for I felt this was a service to the nation, and that my retirement would be enough for me. At the ministry of the economy, though, they said we were building grandiose projects. But everything becomes quite clear if we recall that Canitrot said that Argentina is "broke."

Question: You know, Mr Costantini, Argentina is what they seem to be working against.

President's Antinuclear Policy

Bahia Blanca LA NUEVA PROVINCIA in Spanish 15 Jun 87 p 6

[Text] Dr Raul Alfonsin gave two important speeches in Switzerland. What he said to the ILO [International Labor Organization], aside from the inevitable generalities on social rights, included some plausible questions about the foreign debt. Strictly labor issues in Argentina, which had created so much anticipation about this aspect of the trip, were not dealt with, except for a reference to the "social pact" considered as an aspiration.

On the next day he spoke at the Disarmament Conference, and even though Argentina is not one of the countries involved in the negotiations on Euro-missiles, nor is it a nuclear power, or indeed a power of any sort, there he gave another speech on nuclear weapons and the "doctrine of deterrence." If we remember the speaker's position, we realize immediately that this could not have been a political speech in the strict sense of the term, but rather a sort of layman's sermon.

It will be objected with apparent reason that the political significance of this event comes from the fact that Argentina is a member of what is known as the Group of Six, along with Tanzania, Mexico, Sweden, Greece, and India, which uphold these positions. But if the position of each of these countries is considered either individually or as a group in terms of world power, whether nuclear or non-nuclear, we will have to reach an identical conclusion on the nature of this speech.

The president said that he disagrees with the "doctrine of deterrence," which claims that it is the superpowers' enormous capacity for mutual destruction that has so far prevented an outbreak of war between them. "That theory never persuaded me," he said. "It has always seemed incomprehensible and dangerous to me." That is perfectly logical, as it would seem to anyone who had not studied the issue in depth.

He then proceeded to compare deterrence to the doctrine of "armed peace" which collapsed with World War I, forgetting that the possibilities of destruction are now much different and are definitely inhibiting. And he rejected fear as a factor for peace, while he accused nuclear weapons of being a source of distrust between the superpowers and above all, of causing excessive spending that could be put to better uses, etc. He even quoted Bertrand Russell.

What isn't so easily understandable is the positive part of the speech; in general it seems to be an attempt to "modify traditional or even ancestral patterns of behavior"; specifically, by halting nuclear testing and the militarization of space. We do have to admit that the members of the Group of Six have observed all these principles and points of behavior strictly.

It is true that, in the meantime, the possibility of MAD [Mutually Assured Destruction] which nuclear armament creates has imposed on the world a state of "forced peace" or "non-war" between the major powers, which is something. And on the other hand, since 1945 approximately 25 million human beings have died in dozens of conventional wars. Conventional weapons have been more terrible than nuclear arms, which, precisely because of the danger of self-destruction using them would create, remain dormant in their silos.

That isn't all, for if nuclear forces were to disappear, then the Soviet Union, the owner of the most formidable and numerous conventional weapons in history, would probably feel impelled to exploit its advantage. This means that the risk of war would be much greater than it is now. In summary, it might perhaps have been more appropriate for our president to have restricted his remarks in Switzerland to a discussion of the foreign debt and similar issues without venturing into planetary strategy.

He has probably projected onto the rest of the world his own bizarre concept of Argentina, which he has invested with a memorable historic originality; according to his statements for some time now, Argentina is a nation (perhaps the only one in the history of humanity) which "has no assumption of war." If this phenomenon were universal, then not only would there be no nuclear weapons; there would be no sort of arms at all, and we would all be good and happy, as it seems that we all are in Argentina.

Nuclear 'Paralysis'

Bahia Blanca LA NUEVA PROVINCIA in Spanish 15 Jun 87 pp 1, 3

[Article by Martin Olivera]

[Text] With a mixture of amazement and hope I read in yesterday's LA NUEVA PROVINCIA a report published on the former CNEA chairman, engineer Alberto Costantini. I read it with amazement because of the gravity of what he was relating. I read it with hope because at last something about the methods being used to assassinate the Argentine Nuclear Plan is coming out into the open. At one time this plan was a source of real pride, unlike the frequent outbursts of empty national chauvinism.

The only state organization that managed to rise above the constant changes in governments (for we know, in Argentina everything that the previous administration did is wrong), without halting its progress, the CNEA was also able to elude the income-generating zeal of Martinez de Hoz and his people,

and even to defeat the powerful lobby connected with conventional energy sources. But in spite of its past history, it doesn't seem that it will be able to survive the present administration.

For the uninitiated, nuclear matters are closely linked with the military (even though that is the only nuclear application that has never been developed in Argentina), and the military have a bad press among the radicals. So it wasn't surprising that almost as soon as they had come into office, the constitutional authorities should see what could be done to dismantle the nuclear plan.

This undertaking began when the minister of foreign relations, Mr Caputo, asked with great naivete if the Pilcaniyeu uranium enrichment project could be dismantled, and the political sectors of the administration agreed with the ineffable technocrats, the habitual nay-sayers.

For the first group this was an ideological issue: nuclear = military; military = weapons. The pain this word caused among the government strategists is amply proved by the foreign ministry's plan to block arms sales to countries in conflict, leaving only the Vatican as a potential purchaser of missile-launching frigates.

For the second group, the essence of the matter lay in the few pesos that could be saved on things as useless as nuclear medicine or research. And they also had to stay on good terms with Washington (where other countries' independence in such matters is not looked on with much favor), and it is a fact that with the economic plan being implemented here, there will be no shortage of new energy plants. If there are constantly fewer industries, why would we need more electricity?

Windmills

In this context it is clear that the nuclear plan's prospects were limited and that all Costantini could do was tilt at windmills. Luckily the former director decided not to go out quietly and he told of episodes that should make any thinking citizen's hair stand on end, as it should that of at least some legislators, for they are the people's representatives.

Among my rights as a citizen, I believe that the state is the administrator of the people's property, but in no way is it a medieval owner that can do as it pleases with these resources. And if we abide by the letter of the constitution that government officials are so fond of quoting, it is congress that can adopt resolutions affecting our national patrimony, since the members of congress are the representatives through whom the people deliberate and govern.

These people, though, have remained silent before an attack--whether conscious or unconscious--on the people's property. Perhaps through lack

of information, the legislators did not raise a great outcry about such an abuse of our national sovereignty. But now they know this and they know even more. Now they can ask some questions.

If it is true that the president publicly supported the nuclear plan (Embalse, 31 May 1986), why didn't it become a reality in practice? Is there some authority in Argentina above the chief executive, or is it simply that his subordinates disobeyed his orders? Wouldn't that then be a clear case of subversion of power?

De Facto Paralysis

According to our legal system, a decree can only be modified by another decree or by a law. According to this system, ministers do not sign decrees, but only resolutions. The nuclear plan was enacted by a decree but it is undergoing a "de facto" paralysis created by the ministry of the economy. Isn't this a violation of law? Or did the president perhaps sign some decree invalidating the earlier decrees? Isn't it true that if Atucha II does not begin to operate in 1992 (something that is virtually impossible by this time), it will then be in violation of the National Energy Plan's generating requirements for that period?

Many Questions

Along with these questions, there are many other questions the legislators might ask, such as:

- 1) Is it true that if the Atucha II construction is halted, mining activities, research, and all industries related to this area will also be shut down under its impact?
- 2) Is it true that the ongoing delays in Atucha II have already tripled its original cost?
- 3) Is it true that with the paralysis of the commission, research on construction engineering technology for 350-MW power plants has been halted? These are the plants that were supposed to be built every 6 years after Atucha II begins to operate.
- 4) Is it true that because of this, we might lose the possibility of selling this type of plant abroad, as Algeria had been considering at one time?
- 5) Is it true that Argentina is exporting cobalt at extremely low prices, when with an investment of only \$5 million, we could process this cobalt and earn much higher profits?

- 6) Is it true that if this were done, Argentina could shortly become an exporter of equipment for medical applications of cobalt?
- 7) Is it true that for lack of funds construction of NMR tomographic equipment was stopped? This equipment is used for metabolic x-rays of human organs, giving medicine a revolutionary tool in its fight against disease?
- 8) Is it true that this equipment could be built and exported using Argentine technology?

As the reader will understand, there are many questions, and the government has offered very few answers. It would be appropriate to have these questions answered, so we might learn if we are living in an incipient democracy or if we are trapped in a dictatorship of technocrats.

Plants Center of Power Struggle

Buenos Aires CLARIN in Spanish 16 Jun 87 p 17

[Article by Daniel Arias]

[Text] This is an open secret; somebody wanted and still wants to get the CNEA's power plants away from it. With the \$100 million a year that these plants bill even at their low rates, with the additional \$100 million that could be earned by updating these rates (for the government, not the user), and with the ace of spades that generating 15 percent of our nation's electricity represents politically.

The story is a complex one, for there are many sectors interested in a changing of the guard in terms of power plants. These plants have been subjected to a multifaceted power struggle between businesses, ministries, departments, unions and their current owner. Atucha and Embalse now belong to the CNEA and are suffering from all the problems that have been afflicting the Argentine nuclear program since 1985, when the commission's historic budget was slashed to a third of its former size. The pauperization of the parent organization has had a definite impact on the reactors: parts that never get there, experts who are constantly leaving. The Austral Plan had already cut the purchasing power of staff salaries by 19 percent in May 1985. Parts can only be bought once a year--though defects can occur at any time; they seem to ignore the fact that they should wait for parliament to vote on the national budget. In terms of the brain drain, people are leaving at an average rate of one expert every 3 days. They are covered by the same salary scale as any other government employee, but the international resurgence in nuclear activity offers them a gold passport for getting out of their present deadend situation. Employees with extensive training and

inversely proportional salaries--about 500 australs--receive tempting job offers from other countries, of the sort like "bring me seven top-level people and we will pay all their travel expenses." One-way tickets, of course. The CNEA's plants are starting to look like a neuron supermarket.

The loss of both gray matter and parts is creating a possibility that the plants' operational safety may be declining. That is something that doesn't seem to be causing any insomnia at the finance ministry. Just one idea has reigned there since the days of Martinez de Hoz, without ever losing any of its strength or without anyone ever daring to call it by its real name: privatization.

Torpedos and Lifesavers

Privatization is seen as the panacea for all ills: it would provide a release from the bureaucratic sluggishness imposed by state purchasing legislation, salaries would rise above the level imposed by the ceilings set by the public sector, and finally, our nuclear experts would stay at home, and our finance ministry officials could smile with the intimate satisfaction of having saved the treasury a few good australs.

The CNEA's scientists and technicians, though, seem prepared to defend themselves from this sort of solution. "First of all, the fact that the lifesaver is coming from the same place as the torpedo does merit some attention," said Daniel Castillo, leader of the Association of CNEA Professionals. "In a national context of capital drain and speculation, it is hard to believe that a private firm would be able to provide the gigantic amount of self-investment that is needed not for research and development of our future nuclear projects, but just for keeping our present nuclear facilities in safe conditions," concluded the nuclear engineer. The Association of CNEA Technicians, as well as the ATE [Association of State Workers], the UPCN [National Civil Service Personnel Union] and the staff of Light and Power share this idea, an idea that doesn't change much when the Nuclear Club states it. This is an intersector "lobby" that has emerged with force at the heart of the current debacle. In the nuclear week conference which this organization held in the city of Sante Fe, fierce arguments were heard against the finance ministry's activities: "The CNEA is being left without air just at a time when it is showing some serious symptoms of independence; it is designing its own power plants. The technical advances achieved today are not only closing the limited Argentine energy market to outside equipment, but the nuclear industry is even threatening to export its own equipment, something that may be of concern to the current suppliers of the world market," said engineer Oscar Astudillo, one of the event's organizers. "The Argentine nuclear program is already shut down. Privatizing the plants would be the 'coup de grace,' because these plants provide almost the sole certain source of income that the CNEA has, without resorting to passing a hat, in the hope that somebody in the ministry of the economy may deign to open up his hand--even in the current situation in which the CNEA is selling its

electricity to the government at half of the appropriate rate," explained engineer Luis Merello, another of the club's members. "The funding cutoff by the ministry of the economy coincides chronologically with the renegotiation of the foreign debt. This timing seems something more than a pure matter of coincidence," added a member of congress. "Someone decided to attack the CNEA at its best technical moment, but the nation has still not started to debate this issue," commented the scientific journalist, Julio Orione.

Whether they are privatized or turned over to the department of energy, the plants are the very heartblood of the CNEA, and taking them away from it would mean doing away with the CNEA itself. Beyond the issue of who will pay the employees' salaries, the hardware aspect of the CNEA's work gives a definitely practical and market orientation to the considerable brain work done at the CNEA. "We are a team that works with pure research, applied research, technology, the sale of products and services, as well as with setting nuclear policies. I am against any measure that separates people in the lab from people with work with machinery and equipment, or which isolates them all from the people who set the course of the nuclear plan," added engineer Abel Gonzalez, an expert on radiological protection. Scientists from other areas support this opinion: "That would mean cutting the head off from the body. Our national technological structure suffers from a schizoid split between decision-making centers, research centers, and production centers. These activities have always been united at the CNEA; there is no other reason to explain its academic-industrial success. What is researched and discovered there does not stay shut up in a file, nor is it transferred abroad. The CNEA develops specific know-how which is used in the commission's own plants or in Argentine industry," said experts from the National Council for Scientific and Technical Research who attended the Santa Fe meetings.

Will we have to witness the end of this tradition?

The Plant of Plants

Separating the head from the body is not the intellectual monopoly of a few companies and one ministry. The idea created enthusiasm in the corridors of the department of energy, from where it spread to Light and Power, which since 1985 has successfully been involved in the CNEA's divided union panorama. On 3 June the plant safety experts decided to shut them down because the union had suspended maintenance jobs which are essential for their safe operation. Beyond the complex political tangles, there is no lack of very strong reasons for this: a premium would be placed on productivity, one of the many promises never kept, whose instrumentation would boost somewhat the sagging employee salaries. This is an idea which the commission's leaders warily share. "Rewarding operational efficiency with bonuses given to the personnel if they are able to keep their equipment working in sustained production seems an excellent idea to us. We would have to seek some organizational formula so that the thing will not mean that people will try to keep the plant operating at any cost, even if it needs to be shut down for technical reasons," commented several CNEA officials. The department of the

economy was not much inclined to support such an idea, perhaps for fear of stirring up similar demands from other state sectors that have been passed over. If there were some hopes of complicating the life of the new atomic science, which is not at all friendly to concepts of privatization, the move by the finance ministry had little success: the dams are not producing much energy because of water shortages, so Atucha and Embalse are now playing an important role in the national electricity network: temporarily, these plants are lighting--or leaving in the dark--20 percent of the nation's light bulbs. If in addition to this we mention the fact that the nuclear personnel, even though they are divided into many different unions, seem to have collectively and definitively lost all patience with the finance ministry, it now seems that for once the economic team may have seen that the cards were badly shuffled this time.

The conflict that shut down the plants is barely an indication of the minefield that our nuclear program is being forced to cross today. Too many people with too much power from too many sectors want too much to divide it. Cut off from its plants, the nuclear project becomes unviable. The present CNEA leadership, even though besieged by hunger, seems determined to maintain the organizational, scientific and technological integrity of the institution. 1987 is a decisive year.

CNEA Fights for its Budget

Buenos Aires CLARIN in Spanish 19 Jun 87 p 23

[Article by Eleonora Gosman]

[Text] Wednesday night's meeting held between CNEA officials and the secretary of finance, Mario Brodersohn, to seek agreement on the resources to be allocated for nuclear plan projects, covered only in part the expectations sought by the staff of Dr Emma Perez Ferreira.

In principle, the investment profile for the rest of this year for the major projects, Atucha II and the Industrial Heavy Water Plant, was supposed to emerge from this meeting, along with an arrangement for a financial mechanism, in other words, a way of determining the means of payment. With that in mind, attache cases in hand, Dr Perez Ferreira and her closest colleagues set forth before the secretary a budget option which, while it does maintain the total amount originally scheduled, modifies the composition of the sources of this funding.

This was the proposal: the 1.491 billion australs considered for this year for all of the commission's activities would be made up from 578 million provided by the national treasury, a figure to which another 1 million australs coming from an advance recovery would be added. The remaining 911 million australs--which includes basically the funds allocated for construction projects--would be financed by 397 million australs in the equivalent

in foreign currency coming from loans from abroad; 209 million australs obtained from their own resources, and 305 million australs to be made up from bonds.

The changes introduced in relation to the earlier plan are centered in the resources corresponding to foreign credits, which in the new option would increase by almost 100 million australs, and in the funds to be financed with bonds, here reduced by an identical amount, declining from 400 to 305 million australs.

The latter point enables the CNEA, as its authorities then expected, to get back on track with the negotiations in terms that would be more acceptable to the minister of finance. Specifically, the issue of bonds to cover the 400 million australs was the focal point of the dispute between Brodersohn and the former head of the CNEA; the replacement of these public securities by 5-year nontransferrable promissory notes, a means of payment that the contractors for Atucha II and the heavy water plant rejected, and which precipitated Alberto Costantini's resignation.

Future Steps

The rapprochement of positions in Wednesday's meeting still doesn't mean that the definitive solution is about to dawn. In the first place, the issue of the method of payment remains unresolved. Brodersohn indicated that he would prefer to keep the matter on a waiting list until the commission works out its pending profile for 1988.

Still they did pave the way for a decision on the level of resources to be used in the rest of this year in the budget plan that the CNEA will have to submit for the coming period. In order to comply with this obligation, the commission will have to take some preliminary steps: first it will have to meet with officials of the department of energy and study together alternatives for reprogramming the time of execution of the third nuclear power plant, based on the energy sector's overall needs. The date was set for today and undersecretaries working in this area will take part in it, as the secretary, Jorge Lapena, is traveling in the United States.

With all this information in hand, the CNEA officials will again meet next Monday at 1900 in Brodersohn's office. "We are reviewing various alternatives to offer him, which essentially involve the time variable. This means that we will have to expect the completion of Atucha II, scheduled for 1992, to be delayed for at least 2 years; the heavy water plant would then be completed 1 year earlier, so that it can provide in a timely fashion the supplies the power plant will need," said a high-level CNEA official.

If we think about the complexity of these negotiations, it is hard to believe that the final agreement will be reached before mid-July. At that time there will only be 5 months left to do the work at the normal pace; this is such a short time that it will become impossible to spend all the funds allocated. So the finance ministry will have produced some additional savings.

NUCLEAR PLANT WORKERS DEMONSTRATE OVER SALARIES

PY161716 Buenos Aires DYN in Spanish 0240 GMT 16 Jun 87

[Text] Buenos Aires, 1 Jun (DYN)--Representatives of Argentine Nuclear Enterprise for Electrical Power Plants (ENACE) workers association today met with Reynado Puscetto, the Presidential Intercongressional Relations director. The workers demanded an answer to their salary demands which have been submitted to Presidential Secretary General Carlos Becerra.

The union leaders came to Government House leading a demonstration of over 100 ENACE workers and demanded to meet with Becerra.

Puscetto explained to the workers that the petition, which was submitted by ENACE on behalf of its workers, had been sent to the National Commission for Atomic Energy (CNEA) who returned it to ENACE for direct negotiations with its employees.

During the meeting employees argued that personnel working at the German private enterprise of the same sector, and ENACE, had received equal salaries until 1981, but that personnel of the Germany company have since received salary adjustments according to the cost of living index, while ENACE employees have not received the same benefits.

During the demonstration, ENACE employees shouted slogans and disseminated leaflets lashing at, among other things, "the low salaries and the delays that inevitably produce a drain of specialized professionals and technicians."

The workers also warned that "we are facing the imminent danger of not being able to fulfill international agreements with Third World countries which have placed their trust in us."

/9604

CSO: 5100/2109

LABOR CONFLICTS ADD TO CNEA DIFFICULTIES

Plant Shutdowns for Safety Reasons

Buenos Aires CLARIN in Spanish 6 Jun 87 p 16

[Passages enclosed in slantlines printed in boldface]

[Text] The National Atomic Energy Commission (CNEA) resolved yesterday /to take out of service the two nuclear power plants/ that are linked to the National Interconnected System (SIN) of electrical power, Atucha I and Embalse. /The measure means that the grid will have to do without some 1,000 mw of power formerly supplied by these two plants,/ and therefore guarantees /power cutoffs during peak consumption hours in the next few days./

The atomic energy agency explained that it made the decision for /"safety"/ reasons, because the work stoppages threatened by the workers at the two plants about 5 months ago when they demanded better wages involve the risk of /"human error."/

The impact this event will have on the normal supply of electricity was of concern to Energy Secretariat officials yesterday. The situation is complicated by the problems encountered at two other key plants in the SIN: Apparently /the contribution from El Chocon has declined considerably due to the low level of water in the reservoir; the same is true of the Salto Grande dam,/ although in this case it is the rise of the Uruguay River that has reduced the generating capacity. CENA officials reported that the accumulation of corrective and preventive maintenance tasks that have still not been done is so great that it was absolutely imperative that the plants be shut down.

Conflict

The labor conflict at Embalse and Atucha I has been going on for several months. It dates back to the term of the previous CNEA chief, /Alberto Costantini,/ who had agreed to /an improvement in pay scales in the form of a productivity bonus/ that would be tied to the availability of the plants. The agreement had been signed late last year with the Light and Power trade union and the various labor organizations representing engineers, technicians, and administrative workers at the plants.

The difficulties encountered by the atomic agency with respect to the projects in the nuclear plan, the result of the Finance Secretariat's refusal to release the allocated funds, delayed its response to the employees' demands. The problems mounted as the Economy Ministry persistently failed to take a clear stance, and as a result /Costantini resigned/ after a month of total anarchy in the CNEA.

Dr /Emma Perez Ferreira/ was named to replace him, and she immediately set out to overcome the labor conflict. But her efforts were thwarted by the Finance Secretariat's reluctance to implement the raise the workers were demanding. As a corollary to this process, the Light and Power trade union decided to begin /forceful measures/ 2 weeks ago. These measures involve stoppages lasting 3 hours each shift, to be increased gradually.

Toward the end of last week, the technical committees of the two plants (made up of the department chiefs) submitted a report to the Office of Nuclear Power Plants in which they recommended /taking the plants out of service./ The argument was overwhelming: The low morale of the employees creates the conditions for a "human error" which, in this type of facility, could have unforeseeable consequences.

The professionals at the Embalse plant, for their part, pointed out that /"at no time did the staff endanger the plant's safety,/ because /the people were always willing to return to the facilities in case of any emergency."/ Nevertheless, they did admit that /"the low morale is real,"/ and acknowledged that /the lack of adequate maintenance "makes it impossible to predict how long the plants will remain intact."/

The serious nature of the situation had its effects; the committee on public sector wage policy, which comes under the Economy Ministry, finally hammered out an agreement yesterday with representatives of Light and Power and the Commission (see box) for a possible solution. The employees, however, must still hold assemblies to vote on the proposal, and that will take time. /It is estimated that Atucha I could come on line again in a week and a half, while Embalse will take 2 weeks. This is enough time for the population to feel the effects of the electricity shortage./

[Box, p 16]

Risk of Human Error

The shutdown of the Atucha I and Embalse nuclear power plants, which were taken out of service to prevent the consequences of the partial work stoppage called by the employees, is /a new episode in the crisis that has plagued the National Atomic Energy Commission./

In the brief period of 45 days, the government's /indecision/ in the nuclear sphere led to the resignation of the head of that agency, Alberto Costantini, and reduced to a minimum the work on the projects involved in the nuclear plan. /Now the safety of the plants is threatened, as they cannot operate

under circumstances which are propitious for "human errors," and the supply of electricity is contingent on that./

The risks of an /energy shortage/ in the next few days (the National Interconnected System must do without 1,000 mw of power formerly supplied by the two plants) /is the economic and political cost which must be paid for the Economy Ministry's foot-dragging in agreeing to the pay raise that workers have been demanding for half a year./

Official Viewpoint

The /official view of the conflict/ was certainly lacking in perspective. After months of negotiations with the representatives of the Commission and the trade unions involved, the officials under Minister Juan V. Sourrouille decided that the /productivity bonus/ requested by the personnel of these plants (who are responsible for the delicate task of operating facilities of undeniable potential risk) /ran counter "to the norms that govern public administration."/

In this context, the Light and Power trade union which represents the workers at the plants decided to begin forceful measures. /"The refusal to cooperate grew to such an extent that it endangered the corrective and preventive maintenance required by these facilities,"/ explained Dr /Roberto Perazzo,/ an aide to the new head of the atomic agency, /Emma Perez Ferreira./ And this was the determining factor in the decision 2 days earlier to shut down the plants: "There comes a time when we must choose between maintaining safety and providing service," stressed the expert.

The urgent situation finally forced the officials at Finance to abandon their inertia; yesterday they agreed on a /principle of solution/ which consists of a /readjustment of the "supplement for nuclear power plant services."/ According to Perazzo, /this mechanism would entail an increase of 20 to 25 percent over the regular pay./ The alternative must be studied by the employees in the next few days. But even if it is accepted, /the plants cannot start up again immediately. It is difficult to calculate the economic costs involved in these events, but no one can deny that it would have been cheaper to provide a timely response./

Eleonora Gosman

500-kw National Interconnection Grid

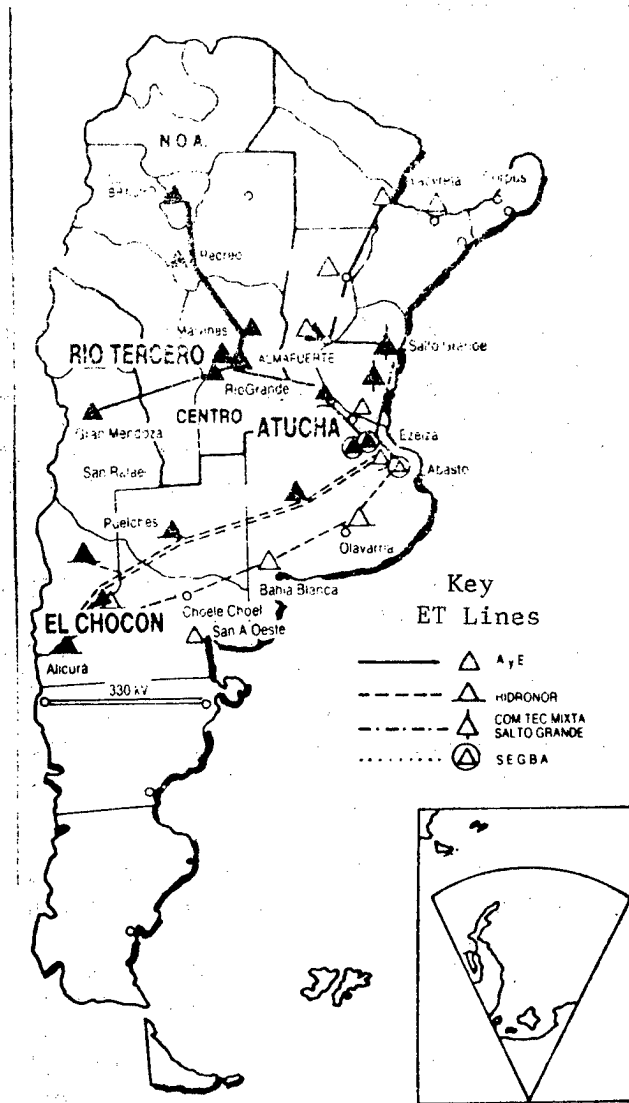

Implications of Shutdowns

Buenos Aires AMBITO FINANCIERO in Spanish 5 Jun 87 p 2

[Article by Martin F. Yriart; passages enclosed in slantlines printed in boldface]

[Text] The /Atucha I and Embalse/ nuclear power plants were taken out of service yesterday for an indefinite period. The National Atomic Energy Commission (CNEA) announced this last night in a press release transmitted by telex at 22:18 hours. According to the statement, "this measure was recommended by the specialized agency responsible for the operation of the plants, because a labor dispute limited to the personnel of those plants /has prevented the fulfillment of routine preventive maintenance plans."/

The shutdown of the plants brought to the fore once again two problems that have been "on the back burner" for the last few months in the CNEA:

--The /pay situation/ of one of the most highly specialized agencies in the country in terms of science and technology.

--The /safety situation/ of the nuclear power plants affected by the lack of a budget, which has prevented the replacement of parts and the optimum desired maintenance of the plants.

Conflicts

/The two plants together account for an installed capacity of about 950 mw, just under 10 percent of the installed capacity of the interconnected public system for electricity generation. They represent, however, a much larger percentage of the "base energy" supply, / that is, those plants which tend to operate at full capacity 24 hours a day.

The CNEA's conflicts with its employees appeared to be headed toward a solution last week /after the new chairman of the agency, physicist Emma Perez Ferreira, submitted a pay readjustment proposal/ within what she regarded as a first step in a progressive recovery program. Before taking office, /Dr Perez Ferreira had exacted from President Alfonsin a promise to support the efforts to obtain the necessary funding from Economy./ The pay deterioration at the CNEA is especially irritating since the researchers of the National Council for Scientific and Technological Research (CONICET) and other scientific agencies received substantial raises this year.

As far as the safety of the plants is concerned, for more than a year the experts of the CNEA safety agency, the Advisory Council for Licensing Nuclear Facilities (CALIN), had been calling attention to a growing series of deficiencies resulting from the failure to conduct preventive maintenance on the facilities and to train technicians as required by the regulations. These procedures were not taking place because of budgeting problems, the lack of personnel, and the absence of a policy on operating the plants. The experts had also noted that the lack of certain spare parts was aggravating the situation. AMBITO FINANCIERO published the complete text of a CALIN report analyzing these problems. /Nonetheless, the former chairman of the CNEA, Alberto Costantini, took it upon himself to continue operating the plants even under those circumstances so as not to compromise the agency's "image."/

Prevention

According to the CNEA press release, "in no case has the safety of the plants been affected." In other words, /the shutdown is preventive in nature, and is not the result of any accident or risk thereof as long as the plants are paralyzed./ The cost of keeping them closed down, however, is added to the other unproductive factors that are weighing down on the CNEA's budget, not counting the power not generated and the higher cost of replacing it with electricity generated by conventional thermal plants that run on oil or coal.

Employee Demands

Buenos Aires LA PRENSA in Spanish 24 May 87 p 4

[Text] The inter-union committee of the National Atomic Energy Commission asked the new chairman of the agency, Emma Perez Ferreira, "to form a board of directors on which the workers are represented through their trade union organizations, within 90 days." It also urged her not to move any further "on the privatization policy and the dismemberment of the CNEA" during that period.

In addition, it asked her to carry out the planning, construction, and operation of the fourth nuclear power plant "with the CNEA alone in charge, following the pressure pipe design concept, as in the Embalse plant, this being the most suited to overall national interests."

In this way, the workers have come out in favor of the Canadian system (CANDU), to the detriment of the German one (Argos Plant).

These proposals are contained in two pages that were submitted to Perez Ferreira by the representatives of the four trade unions that operate in this sector (which have suspended the forceful measures they had been pursuing).

The workers are asking for a 50-percent pay raise, with a basic salary of 350 australes, a payment of 82 percent on the pension annuities, and the regularization of the distortions resulting from the application of supplements as "salary palliatives."

In addition, among other social demands they are calling for the effectivization of all hired workers, the rehiring of laid-off workers, and "the investigation and clarification of all human rights issues in the CNEA: arrests, disappearances, parallel files, blacklists, and the intimidating presence of the National Police."

With regard to institutional policy, they demanded "the participation of organized workers in decisionmaking at the top level of management of the institution" and the "suspension of the policy of privatizing goods and services that are generated and funded exclusively by the CNEA."

They also called for CNEA control of the national and international marketing of radioisotopes.

8926

CSO: 5100/2106

PEREZ FERREIRA STRESSES 'CONTINUITY' IN CNEA PROGRAMS

Buenos Aires LA PRENSA in Spanish 23 May 87 pp 1, 6

[Text] In her first meeting with newsmen after taking office last Thursday, the chairwoman of the National Commission for Atomic Energy (CNEA), Dr Emma Victoria Perez Ferreira, expressed various thoughts on the commission's operations and its future nuclear energy plans.

Contributions of All

First of all she thanked "President Alfonsin for the trust that he has placed in us by giving me the responsibility of heading the commission. And I say 'us' because my interpretation is that by selecting one of the longest-standing members of the CNEA, he wanted, above all, to acknowledge how important the contribution of all workers has been and will be in achieving the basic objective of domestic nuclear activity: furthering the country's economic, scientific and technological development by mastering a technology that has an unquestionable multiplier effect in other activities."

She then underscored that the CNEA "cannot be an island in democratic Argentina," asserting that we must "revive the fighting spirit that was traditional in past eras to overcome difficulties."

She went on to say that to this end we have the resolute support of the national government, "with whose sectors that are most directly involved with our problems we have already begun a dialogue that I hope is fruitful." She then added: "We also have the support and inspiration of other nations, in particular those at a similar level of development, with which we will continue to strengthen cooperation and exchanges. And we also have the moral strength of knowing that none of the effort, hard work and sacrifice that our people put forth at plants, mining complexes, power plants, factories, laboratories, workshops or offices, will ever be used for destruction, given our government's categorical policy and actions for nuclear disarmament."

Just Grievances

Afterwards, in response to questions, Dr Perez Ferreira said that she has met with staff and regards the "wage and union demands that they put before me as just grievances."

"I found extreme uneasiness," she said, "and we arrived at an understanding that will be the basis of future negotiations, which I hope will enable us to overcome our differences, always with the maximum involvement of our staff."

Nuclear Policy

When asked about the commission's plans, in particular regarding Atucha II and the construction of the heavy-water plant at Arroyito, Dr Perez Ferreira began by indicating that "1 week is not enough time to assess all the possibilities. Our intention is not to introduce discontinuity into the commission's long-range programs, because then there would be no chance of rectification. We have to conduct a reformulation that does not encourage expectations that are disappointed in the years to come. We need continuity and specific programs in keeping with the country's actual economic conditions," she specified.

8743

CSO: 5100/2107

FORMER CNEA CHAIRMAN ANSWERS CRITICS OF SECTOR

Buenos Aires AMBITO FINANCIERO in Spanish 25 May 87 p 6

[Text] Alberto Costantini has leveled veiled criticism at those who oppose Argentina's nuclear program. The engineer was speaking at a luncheon at the Circulo del Plata, which is headed by Dr Marcelo Sanchez Sorondo.

The former chairman of the National Commission for Atomic Energy (CNEA) was responding to "the remarks that an Executive Branch minister made about the nuclear program. He stated that the program has a heavy military component, when in fact the philosophy of the Argentine nuclear program is to develop a maximum of applications linked not only to research and technological development but also to meeting the country's energy needs in the 21st century."

Worrisome

"These remarks are somewhat worrisome," he went on to say, "because they tend to cast doubt on one of the country's most important activities here at home and abroad."

Costantini spoke to a large audience on the very day that Dr Emma Perez Ferreira took charge of the CNEA. In the audience were Gen Jorge Arguindegui, retired, Antonio Lopez, Edgar Sa, Francisco Uzal, Navy Captain Cohen, Marcelo Lascano and Enrique Peltzer.

"Second, I would like to refer to the comments that have been made in the Economy Ministry. They range from those who regard CNEA projects as pharaonic, to those economists who talk about other methods of power generation, like gas, and who wind up saying, without offering further arguments, that the CNEA is a luxury that we cannot now afford."

Bewilderment

"This second point is profoundly bewildering," Costantini said, "because many in the current generation of economists would seem to be condemning our country to mediocrity, dependence and stagnation, practically forever."

In an obvious allusion to official policy he noted: "After having passed the 70-year mark and as I look back on five decades of stagnation in the republic and when I hear these depressing, pessimistic remarks today, I must say that I am somewhat pessimistic about the future of the republic."

ARGOS VS CANDU DECISION CONDITIONAL TO SAFEGUARD ISSUES

Surrey NUCLEAR ENGINEERING INTERNATIONAL in English May 87 p 2

[Text]

In what it sees as "stepping out into the market place", Argentina's national nuclear engineering company, Enace (which is owned 75 per cent by CNEA (Comision Nacional de Energia Atomica) and 25 per cent by KWU) has launched its own design of 380MWe heavy water reactor.

Called the Argos PHWR-380 (see feature article and wallchart pp24-34) the plant uses the technology employed in the 367MWe Atucha I unit (which has been operated since 1974) and the 745MWe Atucha II plant (which is under construction), but with enhanced safety features and significant upgrading. Although the current version of Argos is equipped with a steam supply system of the pressure vessel type, the company is also prepared to offer a pressure tube version of the NSSS.

Enace believe that Argos is particularly suitable for developing countries - Algeria is one such country said to be showing interest - and is also likely to be selected as the basis for Argentina's domestic nuclear programme in preference to Candu pressure tube heavy water units. Argentina already has a 600MWe Candu plant in operation, at Embalse, but future use of Candu technology is likely to be precluded by safeguards disagreements with Canada.

Argentina is not a signatory of the NPT

Pondering future reactor choice. A committee of the CNEA is now expected to make formal recommendations to the government in May on

what technology should be selected for Argentina's future nuclear power plants. Presentation of the committee's proposals had been previously scheduled for 21 March.

The Argos design was formally presented to the committee by Enace on 10 March, while Candu plant options were, in an eleventh-hour move, presented to the committee on 31 March by a group of Enace people with experience on Embalse and sympathetic to Candu - hence the delay in the formulation of the final recommendations. Official support for any Candu project by AECL would be conditional on resolution of safeguards issues. But the Enace group believes technology transferred in the course of the Embalse project could form the basis for future projects.

The current energy plan envisages a further 700MWe of nuclear capacity in operation by 2000 (in addition to Atucha I and II and Embalse). The committee is now considering various ways of meeting this additional capacity requirement: one 700MWe Candu; two smaller Candus; or two Argos PHWR-380 units.

As well as finalizing the choice of technology, the committee is also expected to recommend potential sites. Hernandarias in the province of Entre Rios is one site that has come to prominence in the Argentinian press over recent weeks.

Increasing self sufficiency. The fact that Argentina is now offering an indigenously designed nuclear power plant is a measure of the high level of self-sufficiency.

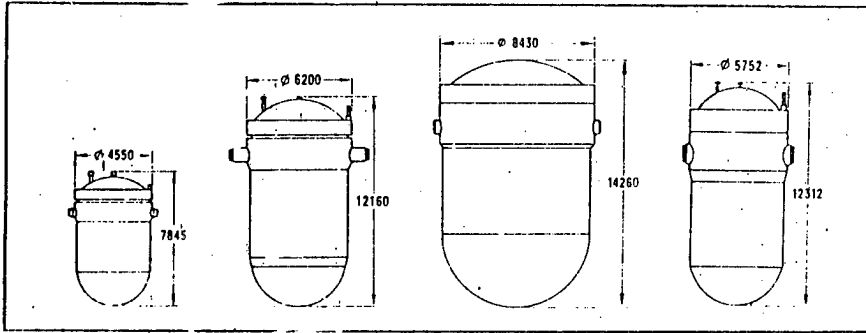

The reactor pressure vessel for Argentina's 745MWe Atucha 2 plant arrived on site on 16 March. As well as being one of the largest nuclear pressure vessels ever made it must also be one of the most multi-national. Its manufacture has involved Japan, Brazil, Germany, Spain, Switzerland and the Netherlands, as well as Argentina. The Atucha II vessel (971t) is shown second from right. For comparison, a 1300MWe Convoy vessel (570t) is shown, on the same scale, far right. Also shown, far left and second from left, respectively, are the vessels for the 58MWe MZFR prototype nuwr plant in FR Germany (on which the Atucha design is based) and the 367MWe Atucha I vessel (470t). Atucha II is scheduled for completion in 1992.

iciency which the country is aiming to achieve in the nuclear energy field.

Argentina is in particular striving for a completely indigenous fuel cycle - from uranium mining, through UO_2 production and fuel manufacture to reprocessing. Fuel fabrication has been established at Ezeiza, while Zircaloy tube production is expected to reach commercial scale by 1990. A 250t/y heavy water plant is being built by Sulzer Brothers at Arroyito for completion in 1988.

One of the key features of Argos is that it is capable of operating with a range of fuel cycle options including plutonium-spiked fuel and low-enriched uranium (heavy water moderated reactors normally operate with natural uranium).

These options are seen as ways of extending the life of uranium reserves. Argentina has a pilot scale reprocessing plant due to enter operation in 1989, with a view to developing mixed oxide fuels. In addition a small gaseous diffusion enrichment plant is expected to enter operation at Pilcaniyeu this year. **The Iranian connection.** It is 20 per cent enriched uranium from this plant that could be supplied to Iran for research-reactor use, if current discussions prove successful.

Another reflection of closer links between Argentina and Iran, following the two countries' nuclear co-operation agreements signed 18 months ago, is the proposal that an Argentinian-Spanish-German consortium, including Enace, Empresarios Agrupados and KWU, should complete unit 1 of Iran's

twin-1200MWe Bushehr plant, on which construction started in 1974 and was suspended in 1979. Preliminary agreement between the parties has been reached on how the members of the consortium might work together. The precise status of the plant - very roughly 70 per cent complete - is now being analyzed, with the intention of providing a proposal to the Atomic Energy Organization of Iran. Some parts of the plant are said to have been very well preserved and maintained, others less so. There is however reluctance to get involved in site work while the Gulf war continues.

Argentina has been involved in the export of nuclear know-how before, and test reactor plus associated research centre in Peru. □

/9274

CSO: 5100/2112

ARGOS SAFETY FEATURES TO ENHANCE MARKET POSSIBILITIES

Sutton NUCLEAR ENGINEERING INTERNATIONAL in English May 87 pp 24-34

[Article by A.J. Gonzalez, K. Frischengruber, J.A. Recalde, R.B. Solanilla, and R.C. Vanzulli]

[Text] Argos: "many eyed guardian" of nuclear plant safety.* Reactor vendors in most countries have had lean pickings for the past decade, and ordering seems unlikely to show much growth until the shock wave from the Chernobyl accident has died away. Paradoxically, however, at least one firm sees a niche in the market. Enace (Empresa Nuclear Argentina de Centrales Electricas) is stepping out into the market place with a newly-designed 380MWe nuclear power plant - the Argos PHWR-380 (Argentine Offer of a Safer Pressurized Heavy Water Reactor of 380MWe).

In the Argos PHWR-380, Enace has adopted new boundary design conditions and has embodied a number of special features to achieve maximum safety and economy in operation. A wallchart depicting a cutaway of the plant is included with this article (facing p28). The flow diagram (see Fig. 1) and main technical characteristics (see Table 1) are practically the same as those of the Atucha type nuclear power plants^{1, 2}. The 367MWe Atucha I plant (CNA-I) has achieved high availability and its overall operating performance has been excellent. Atucha II (CNA-II), a 745MWe unit, is under construction.

In its current version, the Argos PHWR-380 is equipped with a pressurized heavy water reactor of the pressure vessel type, but Enace would also be

prepared to configure it to use a pressure tube reactor design.

The major shareholder in Enace is the Argentine National Atomic Energy Commission (CNEA). Enace is the architect-engineer for the nuclear power projects of the Argentine nuclear programme. It has a licensing agreement with Siemens AG's Kraftwerk Union AG, which is its minor shareholder. Under this agreement, Enace has the right to use the Siemens - KWU PHWR (pressurized heavy water reactor) technology, which was originally developed for the MZFR reactor in the Federal Republic of Germany³, as well as their know-how in pressurized (light) water reactor (PWR) design and construction. The CNEA also has agreements with Atomic Energy of Canada

The authors are with Enace (Empresa Nuclear Argentina de Centrales Eléctricas), Av Leandro N. Alem 712, 1001 Buenos Aires, Argentina.

*In Greek mythology, Argos was "all seeing", having 100 eyes.

Ltd for the transfer of technology related to Candu-type pressure-tube heavy water reactors.

The CNEA and Enace have acquired considerable practical experience from

Fig. 1. Simplified flow diagram. The simplified flow diagram of the Argos PWR-380 is equivalent to that of the Atucha PWR plants. Heat generated in the moderator by neutron moderation and heat transfer is extracted by independent moderator loops and used for preheating the feedwater, enhancing the high efficiency of the plant.

Key: 1 - reactor pressure vessel. 2 - steam generator. 3 - reactor coolant pump. 4 - moderator pump. 5 - moderator cooler. 6 - high pressure turbine. 7 - moisture separator. 8 - low pressure turbine. 9 - condenser. 10 - preheater. 11 - feedwater pump. 12 - main cooling water pump. 13 - main condensate pump.

the construction and operation of the 367MWe Atucha I pressure vessel PWR¹ and the 648MWe Embalse Candu; Enace is currently building Atucha II, which is Argentina's third nuclear plant².

Throughout the development of its nuclear programme, Argentina has aimed for independence, using its own uranium and fuel cycle technology. Its choice of heavy water reactors was dictated, at least in part, by the fact that it enables natural uranium fuel to be used. However, the new design is configured also to accept an optimized low-enriched fuel cycle, and fuel spiked with self-generated plutonium or even spiked with thorium.

Flexibility is thus an important advantage of the new design. Couple that

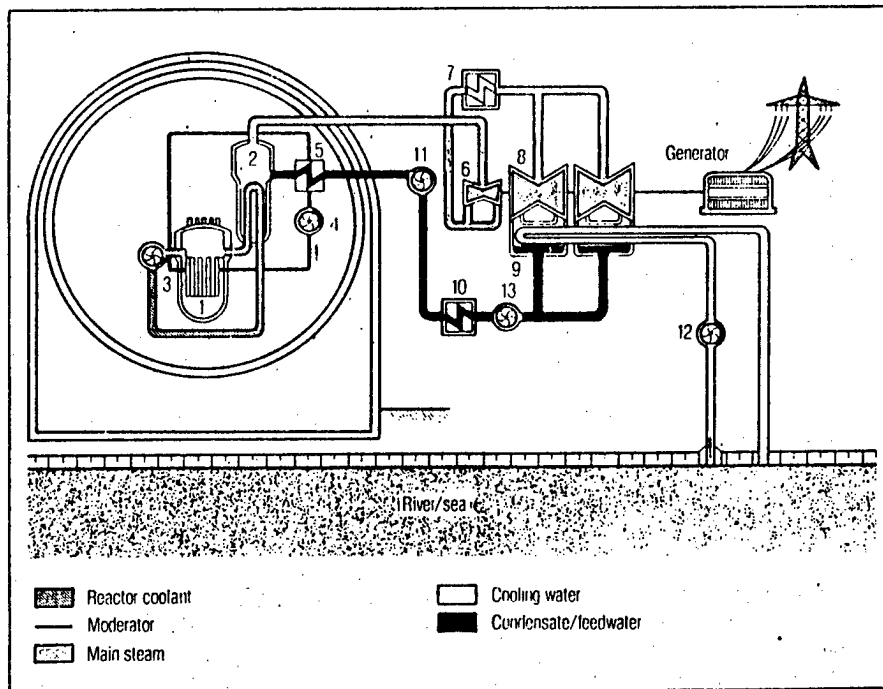

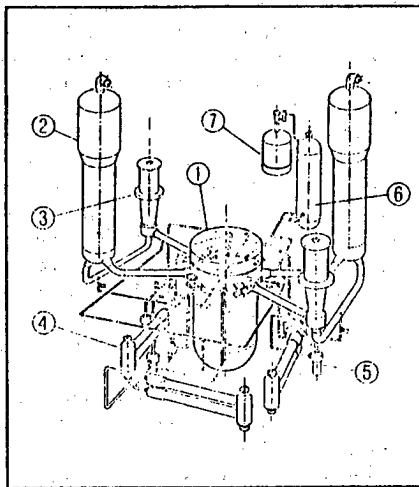

Fig. 2. Reactor coolant and moderator circuit. The reactor coolant system of the Argos PHWR-380 is fully comparable in design and arrangement with that of a PWR. In addition, as is usual in heavy water reactors, there is a moderator cooling system, which is subdivided into three identical loops, each comprising one moderator pump and one moderator cooler. The moderator system is connected with the moderator tank inside the reactor pressure vessel.

Key: 1 - reactor pressure vessel. 2 - steam generator. 3 - reactor coolant pump. 4 - moderator cooler. 5 - moderator pump. 6 - pressurizer. 7 - pressurizer relief tank.

with the fact that in many countries - even in some which have already embarked on nuclear programmes - the grid is too small to accept the "big is better" 1000MWe units which are commonplace in industrialized countries¹, and the Argentine offer begins to make sense.

Throughout, the designers have aimed to ensure that the Argos PHWR-380 complies with the demanding safety requirements of the Argentine national regulatory authority and - automatically - with relevant international safety standards, guides and recommendations, notably those of the International Atomic Energy Agency. Enace declares itself willing to guarantee contractually the applicability of these regulations and recommendations. The design has also incorporated special safety features which reflect the ultimate lessons learned in the nuclear safety field. At the same time, a considerable effort has been made to limit investment costs and to ensure the economic performance of the plant.

Table 1. Comparison of main technical data for Argos PHWR-380 with those for Atucha I and II (CNA I and CNA II)

	CNA I	Argos PHWR-380	CNA II
General			
Reactor type	PHWR	PHWR	PHWR
Gross generator output (MW)	367	375	745
Thermal reactor output (MW)	1179	1123	2160
Reactor core			
Type of fuel	Sintered pelletized natural uranium dioxide		
Refuelling			
	On load	On load	On load
Number of fuel assemblies	253	244	451
Active length (mm)	5300	5300	5300
Burn-up (MWd/t)	6000	6600	7500
Mean fuel rod power (W/cm)	232	223	232
Number of control rods	29	60	18
Main circuits			
Number of main coolant loops	2	2	2
Number of moderator coolant loops	2	3	4
Coolant flow rate per loop (kg/s)	3080	2573	5150
Moderator flow rate per loop (kg/s)	222	150	222
Operating pressure (bar)	113	115	115
Coolant temperature (°C)	262/296	277/314	278/312
Average moderator temperature (°C)	140/210	165/220	170/220
Reactor pressure vessel			
Internal diameter (mm)	5360	5366	7368
Weight of bottom portion (t)	320	320	670

The nuclear steam supply system. The design of the Argos PHWR-380 NSSS bears a close resemblance to a standard two-loop PWR (see Fig. 2). The moderator circuit - a characteristic feature of heavy water reactors - includes a moderator tank (similar to a calandria tank) within the reactor pressure vessel, and three moderator circuits comprising one moderator pump and cooler per loop. Moderator and coolant are held at essentially the same pressure, enabling the use of quite thin-walled coolant channels. As the moderator and coolant systems are interconnected, common auxiliary systems can be used to maintain water quality.

The Argos PHWR-380 pressure vessel and core design is similar to that of the Atucha I and II reactor types (see Fig. 3). The moderator tank contains 244 vertical fuel channels producing 1067MW of thermal power, arranged in a triangular lattice array with a pitch of 27.5cm. The fuel assemblies (one per fuel channel) are identical to those used

in the Atucha designs (37 fuel pins having an active length of 530cm).

Hydraulically-actuated control and shutdown absorber rods are vertically inserted from the upper part of the vessel through the moderator tank. A total of 60 rods is used. Forty-five of them are shutdown rods – allowing for quick shutdown and maintenance of safe long-term subcriticality – and the rest are power and power density control rods. A suitable selection of these vertical control rods provides flattening of the power distribution from the very beginning of reactor operation, allowing the reactor to be operated at 100 per cent of rated power with a nearly fresh core. This system gives the reactor outstanding load-following capabilities.

An operational advantage of the Argos PHWR-380 is that it is designed for automated on-load refuelling (see Fig. 4). There is a single refuelling machine. The fuel assembly transport system is located within the reactor building and

includes a fuel pool with a capacity which can be tailored up to the design lifetime of the plant. The refuelling procedure is monitored from the control room. A special feature is the possibility of inserting irradiated fuel assemblies into the core in the same way as fresh ones. These may include used fuel from other nuclear power plants.

Using natural uranium fuel, a fuel consumption of 0.99 fuel assemblies per full power day (corresponding to 6000MWd/tU discharge burnup) is compatible with a load cycle of 100-80-100 per cent of rated power. In the equilibrium burnup core condition, the fuel loading scheme is three-zone – one-way: that is, fresh fuel is introduced into a channel at an intermediate radial position. From there, partially depleted fuel is shuffled to the core centre and finally to the reactor periphery, from where the fuel assemblies with the highest burnup are discharged. By adopting this radial shuffling scheme

Flexibility in fuel cycle options

The natural uranium consumption of heavy water moderated reactors is around 20 per cent lower than that of standard PWRs with a high burn-up cycle. However, it is also feasible to optimize the fuel consumption further and, thus, to raise the average discharge burn-up, by using advanced fuel cycles.

The Argos PHWR-380 is designed to

accept advanced fuels without significant system or component changes. Several different options have been investigated⁵.

Two important alternatives to the use of pure natural uranium are the optimized low-enriched uranium (LEU) fuel cycle and the plutonium-spiked fuel cycle. Fuel cycle alternatives for the Argos PHWR-380 are shown in the following table.

Main data for various fuel cycle options with the Argos PHWR-380

	Natural uranium option (reference case)	LEU option	Pu-spiked option		
			Natural uranium assemblies (80%)	Plutonium assemblies (20%)	
Fuel consumption (fa/fpd)	0.99	0.41	0.48	0.54	0.06
Average residence time (fpd)	246	594	407	453	814
Fissionable material (%)					
Fresh U-235	0.71	1.00	0.71		0.68
Pu	0	0	0		2.10
Discharged U-235	0.29	0.15	0.18		0.18
Pu	0.24	0.29	0.28		0.81
Average burn-up (MWd/t HM)	6 000	14 500	9 200	11 040	26 000
Average thermal power per channel (MW)	4.6	4.6	4.3	4.6	6.0
Pu production (kg fiss Pu/GWe fpy)	430	215			

Abbreviations: LEU – low enriched uranium; fa – fuel assembly; fpd – full power day; HM – heavy metal; fpy – full power year; fiss Pu – fissionable plutonium.

Note: The vertical dotted line shows average values.

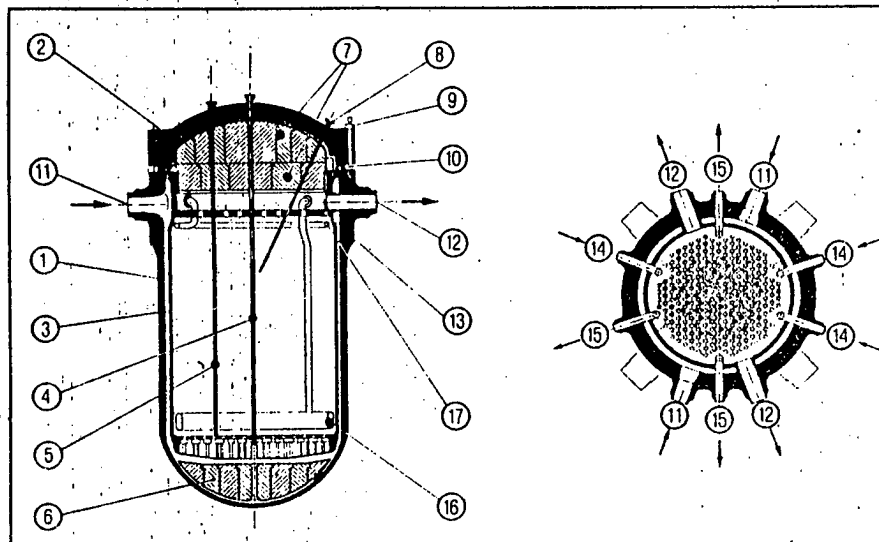

Fig. 3. Reactor pressure vessel and internals. There are 244 vertical coolant channels containing one fuel assembly each. The coolant channels penetrate the moderator tank. The pressure between coolant and moderator is equalized by openings in the moderator tank closure head, resulting in only a slight pressure difference and, therefore, requiring only a thin-walled coolant tank. The 244 coolant channels producing 1067MW of thermal power are arranged in a triangular lattice array with a pitch of 27.5cm. The control and shutdown absorber rods are hydraulically operated. They move vertically. A total of 60 rods is used, 45 of them for shutdown and long-term subcriticality. The remaining rods are power control and power density control rods, designed for flattening the power density distribution over the core.

Key: 1 - reactor pressure vessel. 2 - closure head of reactor pressure vessel. 3 - moderator tank. 4 - coolant channel. 5 - guide tube for control rod/shutdown rod. 6 - lower filler pieces. 7 - upper filler pieces. 8 - boric acid injection line. 9 - stud. 10 - closure joint. 11 - coolant inlet. 12 - coolant outlet. 13 - closure head of moderator tank. 14 - moderator inlet. 15 - moderator outlet. 16 - moderator piping. 17 - moderator piping.

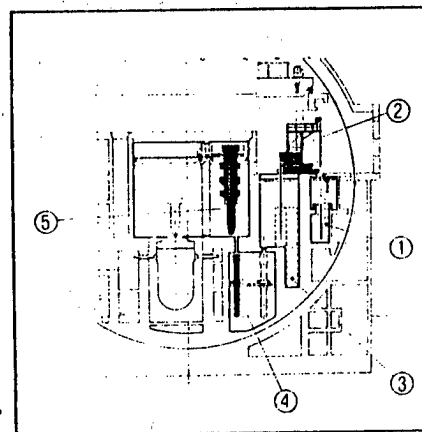

Fig. 4. Refuelling system. The Argos PWR-380 is designed for automatic refuelling during full power operation. New fuel is inserted into the transfer vessel, where a fluid change from H_2O to D_2O takes place. The refuelling machine takes in new fuel assemblies and performs reloading and reshuffling operations above the reactor pressure vessel. The spent fuel is carried to the spent fuel pool in the opposite direction.

Key: 1 - new fuel store. 2 - manipulator bridge. 3 - spent fuel pool. 4 - transfer vessel. 5 - refuelling machine.

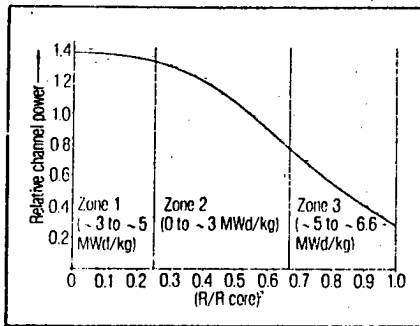

Fig. 5. Radial power distribution. To ensure a flat power density distribution, a radial reshuffling scheme of 3 zones/1 way is applied. This implies that the fresh fuel is introduced into a channel at an intermediate position (zone 2). From there, the partly depleted fuel is shuffled to the core centre, zone 1, and, finally, to the reactor periphery (zone 3). In this way, an average discharge burn-up of 6600Mwd/U can be achieved with natural uranium fuel. In this diagram, distance from core centre is increasing from left to right.

and by flattening the radial power distribution, an average discharge burnup of 6600Mwd/t can be obtained in the case of a minimum reactivity reserve (see Fig. 5). The average discharge burnup can be further increased through the use of advanced fuel cycles.

The Argos PHWR-380 is also an efficient generator of byproducts. The fuel transport system can be used during full reactor power operation to remove specially designed fuel assemblies containing rods for cobalt-60 generation by irradiation. A production of 5.55×10^{16} Bq (1.5×10^6 Ci) of Co-60 per full power year can be obtained without jeopardizing energy availability.

Plant buildings. The Argos PHWR-380 plant includes the reactor building, the auxiliary building and other conventional buildings (see Fig. 6 for the plant layout). The reactor building (see Fig. 7) consists of two concentric spherical structures. Its main purpose is to contain radioactive materials that, otherwise, would – in hypothetical accidents – be released into the environment. The internal sphere is steel and has been designed to withstand the maximum

Table 2. Main features of the regulations on failure analysis applied to the Argos PHWR-380 design

The probability of occurrence of each identified failure sequence, as well as the corresponding activity of released radionuclides, are assessed by using event and fault trees, while taking into account the following criteria:

- The failure analysis must systematically encompass all foreseeable failures and failure sequences, considering common-mode failures, failure combinations and – most important – situations exceeding the design basis. (Failure in this context means an aleatory (chance) event preventing a component from performing its safety function, as well as any other event which may additionally occur as a necessary consequence of such deficiency. Failure sequence, on the other hand, means a sequential series of possible failures which can occur (although not necessarily) after an initiating event.)
- A failure or a failure sequence is selected as representative of a group of failures or of failure sequences. The failure or failure sequence that is selected from the group is that delivering the worst consequences and the analysis takes into account the sum of the probabilities of the failure or failure sequences in the group.
- The analysis considers that a protection function may have lost operability either before the occurrence of the failure or of the failure sequence or as a result of such occurrence.
- The analysis of failures, of failure sequences or of any part thereof is based on experimental data as far as it is possible. If this cannot be done, the valuation methods are validated through appropriate tests.
- Failure rates assigned to safety-related components for evaluating the probability of system failure must be justified. Where justifiable values are not available for some of the components, levels of failure rate prescribed by the competent authorities are used.
- Failure analyses take into account maintenance and testing procedures, and the time interval between successive maintenance and testing actions.
- The failure rates postulated for human actions are justified taking into account the complexity of the task, the psychological stress involved and any other factors which might influence that failure rate, balanced with the level of automation for each interaction of concern.

The doses to the critical group, that would result from the release of radionuclides due to a failure or failure sequence, must be assessed by accepted methods. (The critical group is defined as a group of people, neighbouring the nuclear power plant, sufficiently homogenous with regard to the doses expected to be incurred, and representative of the most exposed individuals in the case of an accident.) The assessment should take into account the meteorological conditions of dispersion at the site and their probabilities. The assessment should not take into account the eventual application of countermeasures, even if they are anticipated in the emergency planning provisions.

The annual probability of occurrence of any failure sequence, if plotted as a function of the resulting effective dose equivalent assessed as indicated above, must result – as a necessary but not sufficient design condition – in a point located outside the non-acceptable area of the limit criterion curve (see Fig. 9). Otherwise, the design must be adjusted accordingly.

pressure which might result from any conceivable loss of coolant or moderator accident. The spherical form was chosen as optimal, taking into account stress distribution parameters.

The steel sphere is, in turn, surrounded by an external spherical structure of concrete, which is intended to act as a secondary containment and as a radiation shield, as well as to resist all external events which might damage the inner containment. The space between the steel and the concrete structures forms the reactor building annulus, into the lower areas of which are placed the most important auxiliary systems. Thus, they are located close to the primary system and to the reactor itself and are well protected against external events.

The reactor building houses not only the nuclear steam supply system but also the refuelling equipment and the 12-year capacity fuel storage pool. The pool can be easily enlarged to meet users' requirements, up to the whole lifetime of the plant. Compartments

inside the containment are classified in two groups, taking into account the radiation levels expected during normal operation: equipment compartments; and operating compartments. The latter are accessible without restriction during normal plant operation.

Other systems are contained in the reactor auxiliary building. They include: the coolant and moderator cleaning and upgrading systems; the nuclear ventilation system; and all the equipment necessary for handling liquid and gaseous radioactive wastes. The building is divided into D_2O and H_2O areas, according to the system types.

All the other buildings are in the so-called conventional part; no special requirements are needed for their design, except that the switchgear and emergency power supply building – reflecting the importance to safety of the equipment it houses – is protected against external events and internally subdivided into three redundant modules, which are physically separated.

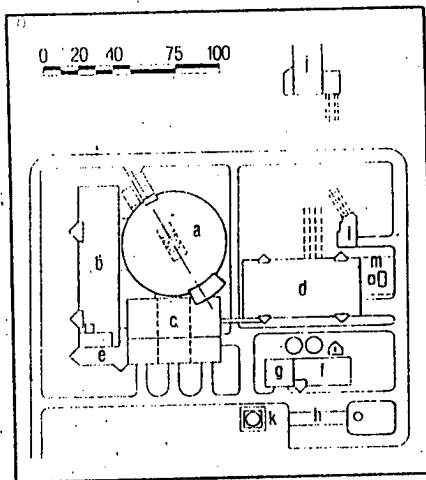

Fig. 6. Plant layout. The balance of plant is designed to ensure economy in construction and operation. The following aspects are considered in the arrangement of the building: clear energy flows, short piping and cable runs; good access for construction, erection, operation and maintenance; adaptability to future extension; and, clear separation of the controlled area for radiation protection purposes.

Key: a – reactor building. b – reactor auxiliary building. c – switchgear and emergency power supply building. d – turbine building. e – staff facilities and office building. f – demineralizing system building. g – auxiliary boiler and air compressor building. h – gas cylinder store. j – cooling water intake structure. k – fuel oil tank. l – service cooling water collecting pit. m – transformer park.

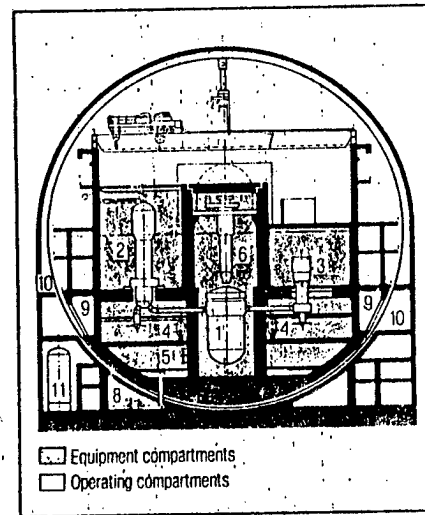

Fig. 7. Reactor building cross section. One of the most important features of the Argos PHWR-380 is its double containment, which consists of two concentric spherical structures: an inner metal sphere; and an outer concrete shield building. The outer concrete shield building acts as a secondary containment and is designed to protect the steel sphere from external events.

Key: 1 – reactor pressure vessel. 2 – steam generator. 3 – reactor coolant pump. 4 – moderator cooler. 5 – moderator pump. 6 – refuelling machine. 7 – reactor building crane. 8 – safety injection pump. 9 – pipe duct. 10 – cable spreading area. 11 – D_2O storage tank.

Using a criterion curve for probabilistic risk assessment

The probabilistic safety assessment performed for the Argos PHWR-380 shows compliance with the criterion curve shown in Fig. 8, which is a necessary but not sufficient condition for nuclear plant licensing in Argentina. The authority's limiting criterion is that an annual risk limit of one-in-a-million must be respected for any individual who might hypothetically be subject to accidental exposures from a nuclear power plant.

Since accidental exposures may result from several accident sequences, an annual risk upper limit of one-in-ten-million must be respected for around ten selected relevant sequences. As each sequence may result in different doses, the criterion curve or limit line shown in Fig. 8 is used.

The logic behind this criterion curve is as follows. For the range of doses from which only stochastic effects of radiation can be incurred, the criterion curve must show a constant, negative, 45° slope in a log annual probability versus log individual dose co-ordinate axis plane. This would ensure that the risk, i.e. annual probability of incurring the dose multiplied by the probability of serious deleterious effects given the dose (the latter being in the order of 10^{-2} per Sievert) will be kept constant.

One of the co-ordinate points in this part of the curve would obviously be the following: | annual probability = 10^{-5} ; individual dose = 1 Sv |, because the product $10^{-5} \cdot \text{annum}^{-1} \cdot 1 \text{ Sv} \cdot 10^{-2} \cdot \text{Sv}^{-1}$ results in an annual risk of 10^{-7} , which is the risk upper bound for any scenario from the postulated initiating events.

In the dose range where non-stochastic effects of radiation may occur (i.e. for individual doses higher than about 1 Sv), the slope of the curve should increase in order to take into account the higher risks of death at these levels of dose. For doses higher than about 6 Sv, the probability of death approaches unity. From this level to

higher doses, the criterion curve should remain constant at an annual probability of 10^{-7} (because the exposed individual would inevitably die regardless the level of the dose).

Between the co-ordinate points defined by | annual probability = 10^{-5} ; individual dose = 1 Sv | and | annual probability = 10^{-7} ; individual dose = 6 Sv |, the criterion curve should show a shape inverse to the dose-response relationship (which, at that range, is roughly S-shaped; however, for the sake of simplification, the regulatory authority has decided to approximate these two points by means of a linear-shaped relationship). Finally, the criterion curve has been truncated at an annual probability level of 10^{-2} , because the occurrence of incidents having a higher annual probability (regardless of the dose) is unacceptable for the regulatory authority.

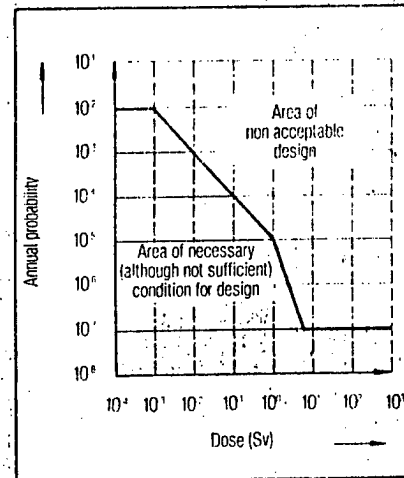

Fig. 8. Limit criterion curve.

Basic criteria. The basic criteria applied to the design of the Argos PHWR-380 implied that:

- It should ensure normal operation within the internationally recommended system of dose limitation^{6, 7}, which has been implemented by the Argentine regulatory authority^{8, 9}; particularly, it should comply with the requirement of optimization of radiation protection.
- It should follow – as a necessary but not sufficient safety condition – all relevant international safety standards, guides and recommendations and, in particular, those which have been issued by the International Atomic Energy Agency¹⁰.

- It should comply with the demanding Argentine nuclear safety requirements, which are based on quantitative probabilistic safety criteria¹¹. In particular, it should comply with a risk limit line (see Fig. 8 and associated panel)¹² following specific probabilistic regulations on failure analysis (see Table 2)¹³ as a necessary safety condition. Besides, through probabilistic safety assessment and decision aiding techniques, it should also ensure that all risks to people are kept as low as reasonably achievable¹⁴, well below the risk limit line. Additionally, it should comply with deterministic requirements connected with the reactor core design; the residual heat removal systems; the primary boundary; the fuel behaviour; the

protection and instrumentation systems; the shutdown systems; the containment system; the main electrical supply; and quality assurance.

● It should reflect lessons learned in the field of nuclear safety. In particular, the power supply to safety systems should be highly reliable, sensitive early detection of coolant and moderator leakages has to be ensured, containment integrity should be assured under any conceivable circumstances, and the radiological consequences of severe accident sequences, even those leading to core melt-down, should be mitigated.

Compliance with these criteria, coupled with the well-known intrinsic safety advantages of heavy water reactors gives the Argos PHWR-380 an extremely high level of safety based on proven experience in nuclear engineering.

Design features for normal operation. The following design limits (note: limits, rather than objectives or goals) have been, in every case, respected:

● For occupational exposures: access to any area where the dose index may exceed 0.5mSv/h is prevented by physical barriers; in areas without restrictions, the concentration in air of radionuclides must be lower than 0.1 of the derived air concentration (DAC) (or the concentration of radioactive materials in air which would expose workers to the recommended limits); no individual may be exposed to concentrations higher than 0.1 DAC and, in any room where this concentration may exist, specific protection devices are provided; maintenance and in-service inspection can only be performed at dose rates lower than 0.5 mSv/h; normal repairs can be performed with dose rates lower than 3 mSv/h, while infrequent repairs can be performed with dose rates lower than 12 mSv/h.

● For exposure of members of the public: design is constrained by a limiting annual dose in the critical group of 0.3 mSv. The collective dose commitment must not exceed 0.015 man Sv per megawatt year of electrical energy generated; effluents can be discharged to the atmosphere only through the stack. Provision is made for continuous

monitoring of the discharge of radioactive effluents into the environment in accordance with international recommendations.

Adherence to such limiting conditions implies, in practice, that the Argos PHWR-380 includes particular radiation protection systems that are not commonly found. For instance, the design incorporates – *inter alia* – systems for the retention of Carbon-14 and for on-line monitoring of tritium in the environment.

Probabilistic criteria and special safety features. A unique feature of the Argos PHWR-380 is that its safety design is mainly based on probabilistic safety criteria, which is a requirement from the Argentine regulatory authority. *A priori* probabilistic safety analyses (PSA) were carried out at the design stage and their results fed back into the reactor design, taking into account the most recent reliability figures and design criteria. Such analyses are not purely theoretical: they are substantiated by the experience gained with the Atucha II (CNA II) safety design, which was also based on PSA. Moreover, the PSA results are checked against quantitative probabilistic safety criteria issued by the Argentine regulatory authority, which are in line with the most recent international developments in probabilistic safety criteria.

As an ultimate effort towards safety, the Argos PHWR-380 offers some unique safety features, such as:

● **High pressure heat sink:** The reactor has a unique safety feature: its moderator system can be used to remove heat in a high-pressure mode. Under normal shutdown conditions, the residual heat can be removed via the steam generators – as in PWRs – maintaining coolant recirculation either by operating the main coolant pump or by simple natural convection. The Argos PHWR-380 includes the additional possibility of using the moderator system as a high pressure heat sink. For this operation mode, the moderator is pumped from the bottom of the moderator tank, cooled in the moderator coolers and injected into the main coolant system. In an emergency core cooling situation, the moderator

How the vented containment system would work

The intended functioning of the vented containment of the Argos PHWR can be exemplified by following a postulated accident scenario, the so-called "emergency power" case, in which the highly reliable emergency power supply would be unavailable and non-recoverable. This is shown in Fig 9.

In such a case, after reactor shutdown, the temperature of the reactor coolant would increase as a result of residual heating in the core. The primary pressure would reach a level that would actuate the safety valve. Primary coolant steam would then flow into the pressurizer relief tank, where the pressure would eventually lead to bursting of a rupture disk. Radioactive coolant steam would then be released into the containment environment, where it would be retained. The design of this extremely important boundary includes provision for sufficiently reliable isolation of pipes and ducts penetrating the steel sphere by redundant valves. Otherwise, there would be an immediate release of radioactive materials into the reactor building annulus, followed by an uncontrolled release into the environment and a subsequent unacceptably high public exposure and environmental contamination.

Hydrogen Ignition. Following the containment isolation, which can be ensured either by automatic or by human action, all consequences would be limited within the containment environment. The core would dry out and eventually melt. The cladding of the fuel rods would burst and its temperature would increase until a zirconium-water reaction takes place. Hydrogen, along with fission products, would be released into the containment environment. There, another important system of the containment would become effective: the early ignition of the hydrogen by appropriate catalysts which will operate without auxiliary power. This effect will ensure the integrity of the containment, by avoiding a later hydrogen deflagration with possible rupture of the steel sphere.

Following this catastrophic scenario and still in the absence of electrical power supply, the molten core is assumed to penetrate the bottom of the reactor pressure vessel and come into contact with the floor of the reactor vault. There might then be an exothermic reaction between the molten core material and the concrete. The released energy would increase the pressure inside the containment significantly (that pressure would already amount to several bar, because of the blowdown of the primary coolant).

Twenty days to failure. One of the most significant features of the Argos PHWR-380 design would now become effective. The containment design pressure of about 5 bar would be reached only after some 10-14

days, when all the short-lived fission products would have already decayed and most of the radioactive material would have been deposited.

This is due to the very favourable relation between the very large containment volume and the comparatively small energy content of the primary system. Without any countermeasures at this stage, pressure would increase inside the containment up to its rupture level, which would take place some 20 days after the initiation of the described hypothetical scenario.

In such a case, the consequences would be extremely modest compared with those from the Chernobyl accident, where such a containment function did not exist.

However, a containment rupture would lead to an uncontrolled release of the radioactive materials still remaining in the containment into the environment. The Argos PHWR-380 design therefore incorporates venting, to permit the controlled release of gases and aerosols from the containment into the environment through a filtering system, relieving the pressure and thus avoiding the containment failure. The efficiency of the filtering system ensures that the resulting projected dose to the most exposed individual must not exceed, under any circumstances 0.1 Sv.

Fig. 9. Possible accident scenario showing how the vented containment system might be used.

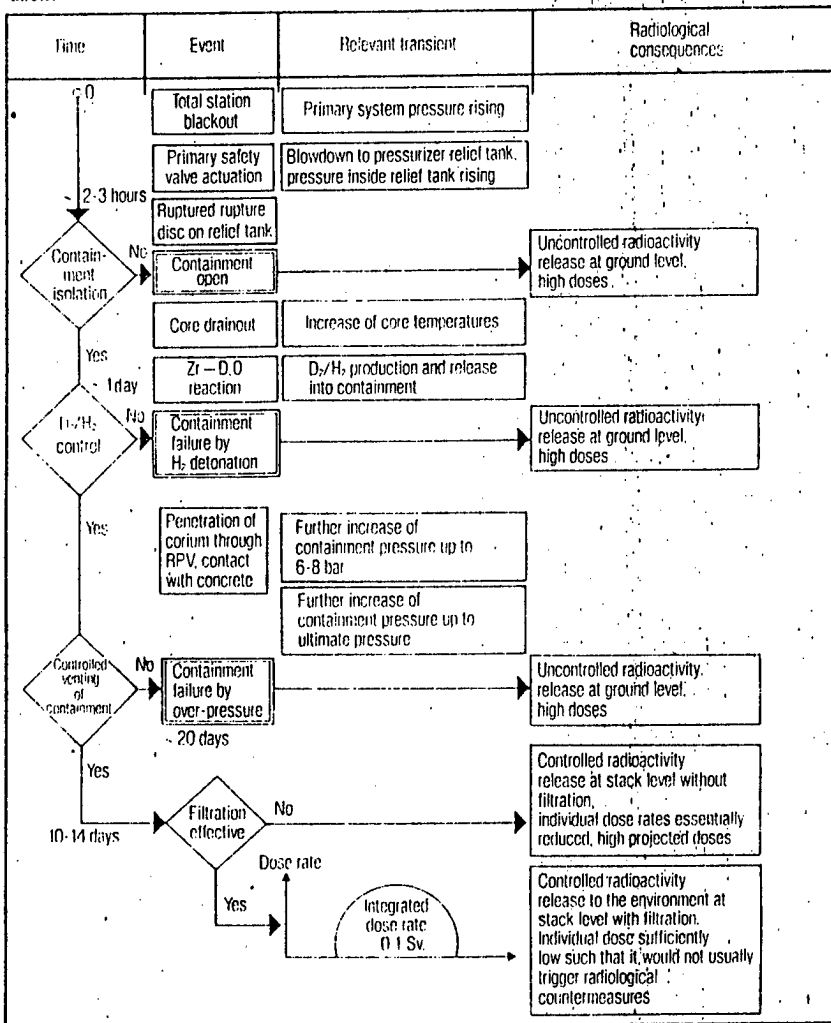

system serves also as a high pressure injection system. The necessary computations for the different operation modes are performed automatically according to the general design philosophy requiring that no operator action should be necessary within the first 30 minutes after any conceivable incident.

The high pressure residual heat removal (RHR) system is designed for high pressure and temperature. In all conceivable incidents, it can keep the reactor in a hot condition after shutdown as long as it is required or – if convenient – it can cool it down, following a predetermined temperature gradient. All branches of the RHR chain are triply redundant and physically separated. Since the steam generators are also available for heat transfer, the plant has two diverse, high pressure, highly available heat sinks for the different accident sequences which may need to be considered.

● **Auxiliary and emergency power:** One point confirmed by the probabilistic safety assessment of the Argos PHWR-380 is that the power supply is in the critical pathway for risk. Accordingly, the auxiliary power supply has been designed to assure adequate reliability levels and a high degree of protection against interruptions. The system is divided into two diverse, redundant and independent systems, which are located in separate sections of the switchgear building. Moreover, in the case of a common mode failure of the normal power supply, an emergency system takes over the feed of safety-related loads. This emergency power supply system is divided into three redundant systems, which are physically separated. Each of these systems comprises: one diesel motor generator; a non-interruptible AC bus bar; and a DC supply with batteries, rectifiers and converters. In case of a prolonged loss of power, the design also makes provision for an external transportable generator to be switched into the emergency power net.

● **Leak detection:** One of the most important advantages of the Argos PHWR-380 design is the possibility of early detection and location of potential leakage in the coolant and moderator systems. This is achieved by using tritium detection. This is the most sensitive such leak detection method and can

only be effectively implemented in a reactor of the Argos type. Therefore, even the smallest leaks can be detected long before they can threaten the integrity of the primary boundary of the reactor systems. In the case of leakage, localization and further repair can be achieved with a minimum effort and at a very early stage.

● **Vented containment:** Perhaps the ultimate lesson learned in the field of nuclear safety is the need to ensure the confinement of radioactive material in cases of severe hypothetical accidents involving core melt-down. For that purpose, the Argos PHWR-380 is equipped with a venting system whose objective is to prevent the disruption of the steel containment and the consequent uncontrolled release of radioactive materials into the environment that could occur in such an extreme case. Should the pressure increase unexpectedly within the containment, the venting system is designed to stabilize the pressure at a safe value by regulating the release of excess gases and steam into the atmosphere (see Fig. 9). The design criterion is that the result of this hypothetical and extremely unlikely situation will be such that even the critical group of the population would not be exposed to projected doses higher than 0.1 Sv. This level of projected dose would not usually justify radiological intervention or counter measures^{15, 16}.

In fact, the IAEA has recommended (for radiological emergencies) that "the level of projected dose liable to be received in the short term, below which evacuation is unlikely to be justified, will usually be about an order of magnitude greater than the annual dose limits for members of the public". Since the applicable limit for unique situations is 5 mSv, such a short-term dose should be of the order of 50 mSv. An integrated dose rate – over the long term – of the order of 0.1 Sv should therefore not usually trigger radiological countermeasures. This is consistent with recent developments in the optimization of radiation protection in relation to emergency measures.

Breaking through the stagnation. The Argos PHWR-380 should be considered a realistic option capable of breaking through the current worldwide stagnation of nuclear power programmes. This is so, because:

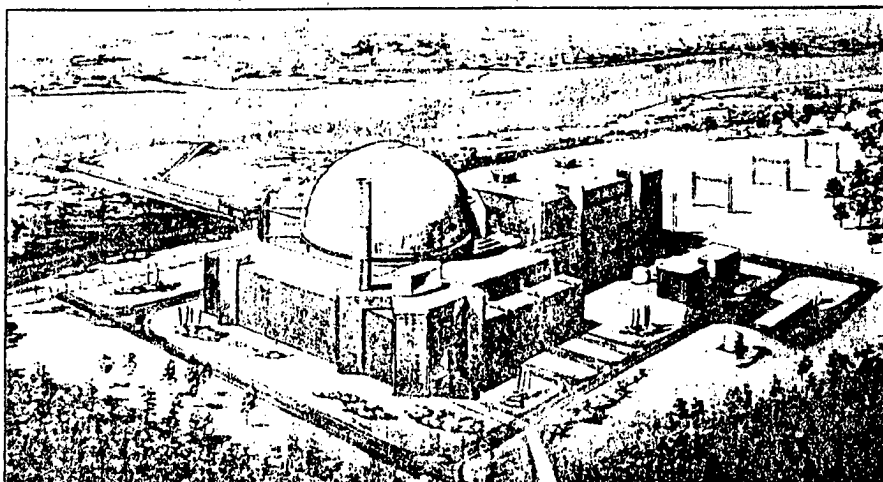

Artist's impression of the Argos PHWR-380 (see also front cover).

- As a medium size reactor, it offers the prospect of reduced financial impact, more involvement of domestic industry, lower indirect costs, simpler adaptation to electrical distribution networks and – possibly – easier public acceptance.
- Its design emphasizes economy in installation and operation; it reflects the worldwide experience achieved via its close relatives, the PWRS.
- It can generate byproducts efficiently without jeopardizing energy availability.
- It is not limited to the self-sufficient natural-uranium fuel cycle but can also be fuelled with optimized low enriched uranium assemblies and even with the plutonium it generates. And – last but not least –
- It offers the usual outstanding safety features of heavy water reactors, but with upgraded design features benefiting from the latest developments in the field of nuclear safety.

And all this has been done not by starting from zero but by building firmly on proven engineering and commercial experience. □

1. G. B. Herzog, K. J. y Sauerwald, *La Central nuclear de Atucha*, Atom und Strom, Year 15, No 4, April 1969.
2. *Atucha II: building a 745MW pressure-vessel PHWR in the Argentine*, Nuclear Engineering International, Vol 27, No 9, September 1982.

3. *Der Mehrzweckforschungreaktor*, Atomkernenergie, Kerntechnik, Vol 46, June 1985.
4. *Small and medium power reactors: project initiation study, Phase I*, International Atomic Energy Agency and the OECD Nuclear Energy Agency, IAEA-TEC DOC-347.
5. K. Frischengrüber and F. Dusch, *Potential and advanced fuel cycles in KWU type PHWRs*, IAEA Technical Committee on Advanced Light and Heavy Water Reactor Technology Development, Vienna, Austria, 1985.
6. *Recommendations of the International Commission on Radiological Protection*, ICRP Publication No 26, Pergamon Press, Oxford, England, 1977 and Annals of the ICRP, Vol 1, No 3, 1977.
7. *Basic safety standards for radiation protection*, IAEA Safety Series 9, Vienna, Austria, 1982.
8. *Exposición ocupacional*, Norma Calin 3.1.1., CNEA, Consejo Asesor para el Licenciamiento de Instalaciones Nucleares, Buenos Aires, 1979.
9. *Limitación de efluentes radiactivos*, Norma Calin 3.1.2., CNEA, Consejo Asesor para el Licenciamiento de Instalaciones Nucleares, Buenos Aires, 1979.
10. *Nuclear safety standards for nuclear power plants*, IAEA Safety Series No 50, IAEA, Vienna.
11. A. J. González, *The regulatory use of probabilistic safety analysis in Argentina*, in Proceedings of the International Meeting on Thermal Nuclear Reactor Safety, Chicago USA, 1982 (NUREG-CP-0027).
12. *Criterios radiológicos relativos a accidentes*, Norma Calin 1.3.1., CNEA, Consejo Asesor para el Licenciamiento de Instalaciones Nucleares, Buenos Aires, 1979.
13. *Comisión Nacional de Energía Atómica, Análisis de fallas para la evaluación de riesgos*, Norma Calin 3.2.2., CNEA, Consejo Asesor para el Licenciamiento de Instalaciones Nucleares, Buenos Aires, 1980.
14. D. J. Beninson, *Optimization of radiation protection as a special case of decision theory*, in Proceedings of the International Symposium on the Optimization of Radiation Protection, IAEA, Vienna, 1985 (IAEA-SM-285/38).
15. *Principles for establishing intervention levels for the protection of the public in the event of a nuclear accident or radiological emergency*, IAEA Safety Series 72.
16. D. J. Beninson and A. J. González, *Optimization in relocation decisions*, in Proceedings of the International Symposium on the Optimization of Radiation Protection, IAEA, Vienna, 1985 (IAEA-SM-285/37).

PROVINCE DEMANDS URANIUM ROYALTIES

PY292106 Buenos Aires NOTICIAS ARGENTINAS in Spanish 1405 GMT 29 Jun 87

[Text] Mendoza, 29 Jun (NA)--Governor Felipe Llaver stated today that the province "will not renew" in September 1987 an agreement with the National Commission for Atomic Energy [CNEA] for joint exploitation of uranium from "Sierra Pintada," the largest mine in the country, located in San Rafael, 250 km south of Mendoza, if royalties paid for the exploitation of this mine are not increased.

The governor added that he will issue a decree to put an end to that agreement because "the province is facing a government resolution that authorizes the CNEA to pass to private hands the trading of uranium byproducts abroad."

Llaver said that under these conditions the province has no other alternative but to cancel the agreement because "the royalties the province receives are not enough to purchase three automobiles a year for official use."

However, he added that "this does not mean breaking relations with the CNEA, but it implies the need for a more equitable economic agreement between the province and the nation."

The "Sierra Pintada" mine is a uranium reserve capable of being exploited up to the 21st century. It is considered one of the largest in the world, and it supplies uranium to the CNEA.

/9599

CSO: 5100/2123

U.S. PRESSURE SEEN BEHIND PERCEIVED NEGLECT OF NUCLEAR SECTOR

Bahia Blanca LA NUEVA PROVINCIA in Spanish 30 May 87 p 6

[Text] The End of Nuclear Policy

The reason for the resignation of the former chairman of the National Commission for Atomic Energy (CNEA), the ongoing shortage of funds, is additional proof of the government's lack of interest in this important field of industrial and energy activity in every modern country. Until yesterday Argentina had been making steady progress in the field, displaying an ability to acquire and assimilate technologies and to train experts that placed it among the world's leaders and gave it a big edge over its Latin American neighbors, including Brazil.

Our skill in an activity in which only countries well endowed with human and financial resources stand out was comforting and a source of reasonable pride. It was also a reason not to despair of our political wisdom, because after all the commission, created in the 1950's and promoted since then without interruption, was fundamentally carrying out a political plan that was pursued with equal vigor by governments of all persuasions, Peronist and Radical, civilian and military, statist and free market.

The plan was not to allow the country to be permanently outpaced or at least to stay close to the most advanced countries in technologies that seemed to herald a new era not only in the military sphere but in the economic arena as well. And to a good extent, or to a great extent given our nation's potential, we were successful, so much so that the last administration of the Process let it be known, to widespread public satisfaction, that the commission had perfected the techniques of uranium enrichment without foreign assistance, using only Argentine resources and experts.

Then came the constitutional authorities, and there was silence about this accomplishment, which ought to be regarded as a joint effort of the Argentine people and as a practical and brilliant example of how the national interest can be placed before the interest of factions and parties when patriotism is present.

No less worrisome was the news about the administration's meager allocation of funds, the suspension of projects under way and, as a symbol of this sudden

and unexpected decline, the resignation of Rear Admiral Madero, who like a gentleman had agreed to advise his successor and who was snubbed by never having his advice asked for. This was why Rear Admiral Madero had to go overseas, where he is regarded as an international authority.

In spite of all this, the administration never tires of saying that an appropriate role for government in the economy is to promote "state-of-the-art" industries. It apparently fails to realize that atomic energy is one of them, that it has a strong local base and that it does not require more funding than is squandered every day on overseas trips by high-level officials, lawmakers and even city councilmen; on the creation of new secretariats, undersecretariats, advisory offices and miscellaneous branches, and on the countless resulting civil service appointments, of which the science of statistics has not yet been able to take stock, no doubt because of the rapid pace at which they are being made.

This policy, or rather, this scuttling of national atomic policy is so inconsistent that intense overseas pressure has been suspected, particularly from the United States, which has always been very mistrustful in this area, in spite of its colossal might, and whose wishes our top officials listen to closely and accommodate. Nevertheless, without an atomic energy policy or industry we have no national security of our own, just security that some great power lends or defends.

8743

CSO: 5100/2107

ARGENTINA

LATIN AMERICA

NUCLEAR PLANT CONTRACT SIGNED WITH IRAN

PY171251 Rio de Janeiro JORNAL DO BRASIL in Portuguese 14 Jun 87 p 21

[By correspondent Rosental Calmon Alves]

[Text] Buenos Aires -- As part of an offensive to gain entrance into the restricted international nuclear industry exporter club, Argentina has signed a contract for the sale of enriched uranium to Iran, which will use it in an experimental reactor. It also intends to participate in the construction of an Iranian electricity-generating nuclear plant. In addition, Argentina has closed other business deals with Brazil, Peru, and Algeria, and it plans to sell to other countries.

A high-ranking Argentine official has said: "We have reached the conclusion that we must export, because our nuclear industry now exceeds our needs after the national atomic energy program was adjusted." He was referring to the serious financial crisis the sector is facing, even after the ambitious targets of the Argentine nuclear program had been reduced.

Shortly before President Alfonsin came to power in 1983, the military government announced that the country had been able to develop its own technology to enrich uranium up to 20 percent. This is why in 1985 Argentina was approved by the International Atomic Energy Agency (IAEA) as one of the countries that could sell enriched uranium to Iran.

The enriched uranium Argentina sells will be used to put back in operation an experimental reactor built at Tehran University 20 years ago by the U.S. company G.A. Technologies. Until the overthrow of the shah, the United States supplied 93-percent enriched uranium for the operation of the reactor, but then the supply was suspended and the reactor was closed down.

At a cost of \$5.5 million, Argentina will now modify the core of that reactor so that it can operate with 20-percent enriched uranium and will furnish 150 kg of that grade of fuel in 30 years. This will make it possible to put the reactor at the Tehran University back in operation.

In addition, with the cooperation of an FRG company and a Spanish company, Argentina has formed a consortium that will try to resume construction of two 1,287-MW electricity-generating nuclear plants in southern Iran. These plants were being built by the FRG company KWU (Kraft Werk Union) when the shah was overthrown and the work was halted. KWU now will take over a third of the contract and its Argentine and Spanish associates will take over the remaining two-thirds, in a deal involving more than \$3 billion if construction of the two plants is resumed.

Argentina intends to export services to various countries, particularly in the Third World. For example, Argentina is participating in bids to provide services in the construction of nuclear plants in Czechoslovakia. This is the first time Argentina is competing with traditional exporters, such as the FRG and Canada.

In Latin America, Argentina has done important business with Brazil, and there are prospects that the two countries will join forces to reach third countries. In Peru, a project for the construction of an atomic center in Huarangal, near Lima, is being completed. This project includes the installation of a reactor designed and manufactured by Argentina. The cost of this project surpasses \$100 million. A similar contract, under which Argentina is installing the reactor, has been signed with Algeria.

/9738

CSO: 5100/2105

BRAZIL

LATIN AMERICA

MINES MINISTER COMMENTS ON ANGRA I LEAK

PY010050 Brasilia Domestic Service in Portuguese 2200 GMT 30 Jun 87

[Report by Vanessa Malta]

[Excerpt] [Passage omitted] Regarding the defect in the reactor of the Angra I nuclear powerplant that was detected last week, Mines Minister Aureliano Chaves stated that the fault does not jeopardize the nuclear system.

[Begin Aureliano Chaves recording] The problems that have affected Angra I have been more of a civil engineering nature rather than a nuclear nature. However, the most recent defect was predominantly of a nuclear nature. There was a small leak of radioactive water, but it had such a small radioactive content that it cannot be described as a defect in the nuclear system. [end recording] [passage omitted]

/9738

CSO: 5100/2114

SCIENTISTS URGE PEACEFUL USE OF NUCLEAR ENERGY

PY101956 Madrid EFE in Spanish 1335 GMT 10 Jul 87

[Text] Rio de Janeiro, 10 Jul (EFE) -- The "Brazilian Nuclear Energy Association [Association Brasileira de Energia Nuclear] (ABEN)" an organization that groups scientists of the state nuclear sector, today demanded that nuclear energy be used in this country only for peaceful purposes.

In a broad report addressed to the National Constituent Assembly that is preparing the new national constitution, the scientists stated that any decision in this regard must be submitted for the consideration of the Brazilian Congress.

The other petition made by "ABEN" is for the final decision for the installation of nuclear plants for the commercial production of electricity, investments in exploitation and research of strategic material, and the designation of the main authorities of the official organizations linked to the nuclear sector to be made by the Brazilian Congress.

The report issued by "ABEN" experts will be studied by the authorities of the Constituent Assembly with an eye to including their recommendations in the new constitution. The other decision made by the Brazilian nuclear scientists is to ask the government to prohibit the import, research, manufacture, and transport of nuclear weapons.

Brazilian President Jose Sarney has repeatedly stated that Brazil will use nuclear energy solely for peaceful purposes and not to promote regional or intercontinental confrontations.

/9274

CSO, 5100/2119

WESTINGHOUSE SUED OVER NUCLEAR PLANT FAILURES

PY201949 Rio de Janeiro O GLOBO in Portuguese 18 Jul 87 p 21

[Text] Furnas Electric Company has filed a suit against the Westinghouse Electric Corporation, the manufacturer of the Angra 1 nuclear plant, with the New York Federal District Court. Furnas is demanding compensation for damages caused by errors in the project design and the manufacture of equipment.

In an official note, Furnas Electric Company says the court action is intended to prove that the nuclear plant's generators and other pieces of equipment will not last 4 years, as the manufacturer claims, because of flaws in design and materials. The decision was a surprise since Furnas has been conducting friendly negotiations for compensation with the U.S. company for 1 year. The compensation money would be used to modernize the 1960's model nuclear plant whose equipment was continuously breaking down.

In its note, Furnas explains that the equipment flaws do not entail risk for the population or the environment. The Brazilian company claims that Westinghouse has not kept it posted on the true nature of the flaws, and is therefore demanding compensation "to compensate for the cost of future modernization and renovation of the Angra 1 plant equipment." Early last week, the thermonuclear generation director from Furnas, Marcio Costa, admitted that the latest failure, which occurred last month, "complicated the negotiations." Costa revealed that the nuclear plant shutdown represents losses of \$6 to \$7.5 million per month for Furnas.

According to the note, the Brazilian company has been trying to reach a friendly agreement with Westinghouse for 1 year. It thought negotiations would conclude last March. However, during the discussion of the agreement terms, the U.S. enterprise refused to guarantee the equipment's performance and offered no acceptable commercial proposition, thus "leaving Furnas Electric Company no alternative other than to seek reparations through court action."

/6091

CSO: 5100/2124

BRAZIL

LATIN AMERICA

BRIEFS

RADIOACTIVE LEAK DETECTED--There is a leak of radioactive water at Angra I nuclear power plant. The management of FURNAS Centrais Electricas [a Rio de Janeiro power company] reported today that company technicians will work this weekend to repair the leaking valve. The primary circuit of the nucleus of the reactor has been losing 100 liters of radioactive water per hour since 23 June. However, according to FURNAS management the radioactive water will not enter the environment. [Madrid EFE in Spanish at 0049 GMT on 27 June in a similar sport adds: "The National Commission for Nuclear Energy (CNEN) today reported in Rio de Janeiro that the Angra I nuclear power plant on the coast of Rio de Janeiro has been closed because of a leak of radioactive water from the cooling system of its main reactor."] [Text] [Rio de Janeiro Rede Globo Television in Portuguese 2255 GMT 26 Jun 87 PY] /9738

CSO: 5100/2110

BRIEFS

PUNO URANIUM RESERVES--Macusani has turned into an important uranium district in Peru, The Peruvian Institute of Nuclear Energy (IPEN) has begun work scheduled to establish an initial reserve of 10,000 tons of uranium, worth \$400 million. This mining district is located in Carabaya Province, Puno Department. [Excerpt] [Lima EXPRESO in Spanish 23 Jun 87 p 19 PY] /9274

CSO: 5100/2119

CONSULTATIVE COUNCIL DISCUSSES NUCLEAR ENERGY

Better Training Urged

NC281812 Cairo MENA in Arabic 1515 GMT 28 Jun 87

[Text] Cairo, 28 Jun (MENA) — The Consultative Council has emphasized that while Egypt believes in peace, it is also aware that peace would only be fragile without a force to safeguard it. This force need not be military; it could be political, scientific, technological, or social. This was stated in the initial report prepared by an ad hoc committee formed by the Consultative Council and headed by member Farkhurdah Hasan to study the Egyptian nuclear program.

The report says in part that the concept of a nuclear program should not be confined to aspects of energy production and nuclear power plant construction. It is a multifaceted national issue with strategic, scientific, academic, and economic dimensions. Additional areas under consideration include research, development, and nuclear power plant safety.

The report recommends comprehensive planning and better training and education as a means to obtain, absorb, and adapt modern technology. It suggests that the planning of industrial and construction activities be improved concomitant with modern technology.

The report also underlines the importance of self-reliance as a means of coping with advanced technology and proposes setting up certain state-of-the-art industries. The report also calls for the utilization of Egyptian expertise in regional nuclear energy development to reverse the current situation wherein regional markets are cultivated solely by foreign industrial corporations.

The report mentions that the Egyptian nuclear program was launched in 1955. By 1961 improvements were introduced to the

experimental reactor and some medical equipment using radiation was manufactured. However, the production of radioactive isotopes eventually stumbled when second-generation nuclear reactors did not arrive in Egypt, as planned, in 1964. Millions in hard currency could have been saved if radioactive isotopes were manufactured in Egypt rather than imported, the report adds.

Following the presentation of this report, the Consultative Council began a wide-ranging discussion of the issue. Many of its members stressed that Egypt has hundreds of capable scientists in this field and that the country's ability to run nuclear reactors has been proved, as in the case of the Inshas reactor, whose hypothetical life was extended due to the alterations Egyptian scientists introduced.

Consultative Council members also discussed the peaceful use of nuclear energy in the fields of medicine, industry, agriculture, and oil production.

The members called for applying modern technology and adapting it to national needs. They maintained that Egypt is no less capable than other Third World countries which have built nuclear power plants and that there should be no fear associated with the commencement of such endeavors.

Some members proposed that a scientific committee of information specialists be established to inform the public of the importance of nuclear energy and to assure them that risks linked to nuclear-power plants can be avoided.

Council Endorses Report

NC291845 Cairo MENA in English 1730 GMT 29 Jun 87

[Text] Cairo, 29 Jun (MENA) — Minister of Electricity and Energy Mahir Abazah affirmed today that the Egyptian nuclear programme would provide, if carried out, the cheapest kind of power production required for implementing all projects of development plans, adding that the government in collaboration with international agency of nuclear safety was keen that the Egyptian nuclear programme have the highest rate of nuclear safety in the new nuclear stations intended to be set up through the programme.

The minister said that the choice of Al-Dab'ah area comes according to criteria and studies covering all Egyptian areas, except Sinai on military grounds, so as to choose the most suitable site.

He asserted that the Israeli nuclear reactor in Dimona is nearer to the delta governorates more than all Al-Dab'ah area, which means that the perils of nuclear radioactive materials would come from Israel rather than from Al-Dab'ah.

He said that the programme will depend on pure Egyptian expertise in the field of nuclear power in addition to foreign expertise of friendly countries which preceded us in the field.

The minister of electricity added that planning for the use of nuclear energy should not be at the expense of the use of conventional energy and a preference should be made between the available alternatives for electric power generating.

The minister also said that the kw/h cost of electricity produced by nuclear power stations is much less than that produced by coal-run power stations.

The nuclear power, Abazah said, is much less in danger than all alternatives contrary to what has been said since the Chernobyl accident which had no effect on the setting up of new nuclear power stations, and 21 nuclear power stations have been set up following the accident.

The minister also pointed out that Egypt will not be exposed to the problem of getting rid of the waste, in case the Egyptian nuclear power programme is implemented and that coordination between the Ministry of Electricity and the Arab Organization for Industrialization has been made concerning the manufacture of some nuclear reactor components here.

The Shura [Consultative] Council approved the special committee's report on the nuclear energy programme.

/9274
CSO: 5100/4612

EGYPT

NEAR EAST & SOUTH ASIA

BRIEFS

NUCLEAR FUEL FACTORY COMPLETED; REACTOR PLANNED--Minister of Electricity and Energy Eng Mahir Abazah has said that the Atomic Energy Commission has completed an experimental nuclear fuel factory in Inshas, which will use the natural uranium extracted from mines discovered in the Red Sea and the eastern desert. This will serve as the nucleus for a main factory that will mark the beginning of Egypt's entry into the nuclear program. Moreover, the old research reactor in Inshas has been modernized and there are currently steps to conclude a deal for a new 20-megawatt reactor. The minister added that the first industrial electronic accelerator in the Middle East aimed at introducing modern technology is now operational. The accelerator cost \$5 million and was a gift from the United Nations. It will be used to improve the specifications of products such as electrical cables, hospital supplies, wood and rubber. [Text] [Cairo AL-AHRAM in Arabic 28 Jun 87 p 1] /9274

CSO: 5100/4612

WRITER ARGUES AGAINST IMPORT OF NUCLEAR TECHNOLOGY

Calcutta THE STATESMAN in English 5, 6 Jul 87

[Article by Brahma Chellaney]

[5 Jul 87 pp 1, 9]

[Text]

THE Union Government's decision to continue negotiations with Moscow on the Soviet offer to sell two 440-MW atomic power reactors has raised important questions relating to the role of nuclear technology imports and international safeguards in our ambitious atomic programme.

Will nuclear imports be consistent with our traditional policy of atomic self-reliance? Does India really need to buy foreign technology to speed up its nuclear power programme? Will the introduction of different breeds of technologies to generate atomic power not complicate maintenance and safety work, disposal of radioactive wastes and the retirement of old reactors? And, more important, what kind of outside inspection is India willing to accept and how would that square with the vaunted atomic independence?

Mr Rajiv Gandhi's recent statement that "we are at present discussing this issue" (of buying two nuclear power units from the Soviet Union) is rather strange. The Department of Atomic Energy, then headed by Dr Raja Ramanna, had rejected the Soviet offer long ago, warning the Government that import of Soviet light-water reactor (LWR) technology would make India perpetually dependent on a foreign power for enriched uranium to fuel the reactors.

Despite this, the Government has preferred to continue negotiations on the Soviet offer, creating immense policy confusion. Earlier this year Mr Gandhi appointed a high-powered panel headed by his scientific adviser, Prof. M. G. K. Menon, to examine the Soviet offer and other possible nuclear imports in the context of our atomic goals, and draw up the

general principles that should govern the introduction of outside technology.

The Menon Committee, in its report submitted recently, has recommended that the Government should not bend the country's traditional nuclear policy to buy foreign reactors. It, however, has concluded that India would be willing to buy outside nuclear technology if the imports met certain basic conditions. These conditions, Professor Menon told this correspondent, are:

The continuity of the Indian nuclear programme is not disturbed. "The programme should continue without any let or hindrance."

The imports do not require India to sign the 1970 Nuclear Non-proliferation Treaty, which introduces a system of atomic colonialism in the world. "We will never sign the NPT."

The safeguards involved do not hinder in any way the country's nuclear power programme.

There is a long-term commitment to supply reactor fuel without any delay or interruption in making the shipments.

These noble principles, as India's bitter experience with the USA on the Tarapur dispute showed, cannot build an arrangement that completely excludes post-deal political arm-twisting by the exporting nation. Acceptance of further International Atomic Energy Agency safeguards on our nuclear energy programme in whatever form, would certainly constrain our atomic independence and provide added legitimacy to a discriminatory inspection system. When we have still not sorted out the dispute with Washington over the Tarapur spent

fuel, which has been accumulating for the past 17 years and creating immense storage problems, it would be unwise to enter into a new reactor deal.

The Soviets are indeed, as the Americans, if not more, in blocking the spread of atomic technologies to non-nuclear weapon States like India; our policy-makers cannot forget that Moscow exploited our heavy-water shortage to force India to accept stringent international inspection of the two unsafeguarded reactors of the Rajasthan Atomic Power Station.

The key question is whether India really needs to import foreign LWR technology. Apparently, Dr M. R. Srinivasan, who succeeded Dr Ramanna as the DAE chief, and some other DAE officials feel that this may be necessary if the country wishes to achieve its target of increasing installed nuclear power capacity from the present 1,330 MW to a staggering 10,000 MW in the next 13 years.

Another set of policy-makers in New Delhi believes that such imports would enable Indian nuclear scientists and engineers to concentrate less on the problem-plagued power sector and more on defence-related atomic research, whose significance is viewed in the context of the developments across the country's borders. Both these arguments, however, are based on specious reasoning.

In the first place, the 15-year profile to generate 10,000 MW of power that was unveiled in 1985 is in itself an overambitious plan. Even if we were to recklessly import nuclear reactors from the Soviet Union and other countries, that target appears difficult to achieve in view of the delays and cost overruns in our own atomic power projects

More important, no solutions have yet been found to the environmental problems caused by atomic energy. It is for this reason that several countries have scaled down their nuclear programme. There is no reason why we should ignore this global development and rush to build a series of new nuclear power plants.

Our scientists are still grappling with the problem about what to do with the crippled, leaking RAPS-I reactor. How India repairs, retires or entombs the reactor will be watched closely by scientists worldwide since a full-size nuclear power plant has never been dismantled anywhere.

The RAPS-I problem shows that it is probably easier to build an atomic power reactor than to dismantle its radioactive core at the end of its 25-year lifespan. There are also other questions on how radioactive systems and wastes should be disposed of, and what environmental hazards are present in that. It would, therefore, be prudent for the government to drastically cut back the 15-year plan.

Also, it is difficult to understand how defence-related nuclear research would be enhanced through imports in the power sector. Moscow's reported willingness to collaborate with India in laser enrichment and fast-breeder technology projects is only a ruse to promote the sale of its reactors; the idea that it could share new technologies with India without adequate safeguards appears far-fetched. A modest, well-regulated and integrated nuclear power programme, relying on indigenous research and manufacture of components, will have greater spin-off benefits for our scientists at the Bhabha Atomic Research Centre and elsewhere.

[6 Jul 87 pp 1, 9]

[Text]

INDIA'S negotiations to buy nuclear reactors from overseas also serve to undermine its potential to export nuclear facilities, equipment and material. The Indian-designed 235-MW pressurized heavy-water reactor, fuelled by natural uranium is perhaps the world's most successful small-sized power reactor and can easily be marketed in Third World nations, since most of them have small electricity grids.

Several developing countries have already shown interest in Indian nuclear research and power technologies. Dr M. R. Srinivasan, the present DAE chief, himself has said that India would be in a posi-

tion to export its first atomic power reactor by the mid-Nineties. How does that fit with the desire to buy foreign reactors?

Any turnkey deal to purchase a foreign reactor would deprive Indian engineering companies of millions of dollars in business. BHEL, Walchand Industries, Larsen and Toubro and several other private and State-run companies have produced reactor vessels, turbo-generators and other essential equipment for nuclear plants. It will only be fair for the Government to help expand the manufacturing capabilities of these and other companies so that they can keep pace with the requirements

of our nuclear programme and, in the process, generate thousands of new jobs in our economy.

The Soviet Union is not the only country that has tried to sell LWR technology to India at a time when the global nuclear industry is being battered by recession. With an eye on the potential multi-billion dollar business involved in the country's 15-year atomic power plan, top executives of 30 French nuclear companies have visited India to explore the market and hold talks with DAE officials. According to Mr George Vendryes, senior adviser to the French Atomic Energy Commission, Paris is willing to sell light-water reactors to India and "ensure uninterrupted supply of enriched uranium fuel for a long time". The DAE, which is concentrating mainly on HWR and fast-breeder technologies, has no plans to indigenously design LWRs, although Dr Raja Ramanna claimed last November that Indian scientists have successfully mastered the art of enriching uranium. There can be no doubt that the introduction of LWR technology would create problems of how to integrate it with the other technologies in use and complicate maintenance and safety-related work.

The Soviet nuclear offer, made to Indira Gandhi by Brezhnev, was originally for a giant 1,000-MW water-moderated, water-cooled VVER light-water reactor (which is different in design from the accident-hit graphite-moderated plant at Chernobyl). But Indian officials pointed out problems of technical management and integration with the regional electricity grid and suggested that Moscow instead offer the terms for building two 440-MW VVER units.

The Soviets accepted the suggestion and began negotiations in late 1983, when Dr Ramanna led a team to Moscow. The following year, after a Soviet delegation visited New Delhi for further talks, the offer was put in cold storage. It was revived on the eve of the Soviet leader, Mr Mikhail Gorbachov's visit to India last year when Moscow threw in an attractive financial package as a bait.

Mr Gorbachov himself pushed for Indian acceptance of the Soviet offer in his discussions with Mr Gandhi. Although the Soviet package includes a long-term loan at a low interest rate repayable in rupees, a deal with Moscow would still be a drain on our national resources and hurt the Indian engineering industry.

But the main problem with the Soviet offer relates to safeguards, as Mr Gandhi revealed on the eve of his visit to Moscow this week. The Prime Minister said the Government did not want Soviet-imposed safeguards to extend to our indigenously-built reactors. This is a clear indication that Moscow has been insisting on "pursuit" or "follow-up" safeguards on the special fissionable material to be produced in the new reactors open to international inspection.

Such a "pursuit" clause in a deal would mean that safeguards would remain in force for generations even after the original agreement has expired and the imported reactor has been shut down for ever. This is because the concept demands that safeguards should apply not only to the imported reactor, but also to its fissionable by-products. The safeguards would "pursue" the fissionable material wherever it goes: if it is used in another facility, that installation would also automatically come under international verification; further generations of material issuing directly or indirectly from the originally produced material would also be safeguarded against use for military purposes.

The Soviet Union, like France, is a member of the London Suppliers' Club, which was formed in reaction to the 1974 detonation of a nuclear device at Pokhran. The club's revised rules require atomic exporters to insist on "fullscope safeguards" while selling any nuclear material or equipment to a non-NPT signatory. Such safeguards are a back-door way of bringing a country into the NPT fold since they require an importing nation to open all its nuclear power and research facilities to outside inspection.

Knowing that there is no question of India accepting "fullscope" safeguards, the Soviet Union has been pressing New Delhi to agree to a "pursuit" clause in verification. Mr Gandhi should end the vacillation in our policy and make it clear to Mr Gorbachov that India would never accept "pursuit" safeguards because they seek to build a system that conforms to the verification goals of Article III.2 of NPT, an obnoxious treaty that places no curbs whatsoever on the five nuclear-weapon States but bans development of atomic weapon capability by other signatories. We have spent four years negotiating with the Soviets on their offer. It is time we told them we do not need their reactor technology.

U.S. SEEKS COOPERATION IN BLOCKING INDIAN MISSILES

Bombay THE TIMES OF INDIA in English 23 Apr 87 pp 1, 9

[Article by J. N. Parimoo]

[Text] Washington, 22 Apr--The United States is seeking Soviet cooperation in preventing developing countries, particularly India, from building an intermediate-range ballistic missile system.

According to reliable sources here, the matter came up last week at the Shultz-Shevardnadze talks in Moscow and the Soviet response was not negative.

In an attempt to prevent developing countries from acquiring ballistic missile capability, seven nations of the western world--the U.S., the U.K., West Germany, Japan, France, Italy and Canada--reached an agreement last week to ban export of missile-related technologies to non-nuclear countries.

The industrialised nations of the west want to retain the monopoly of nuclear weapons and of the missile systems that deliver nuclear weapons.

If the Soviet stand on nuclear non-proliferation is any guide, Moscow and its allies may eventually join the western bloc countries to keep the rest of the world out of the reach of missile technologies.

The Soviet Union is seen here to have helped India to build its own rocket system and develop rocket fuel and a rocket guidance system. The question is whether Moscow will come under the pressure of Washington and stop helping India. There is a nuclear non-proliferation precedent. Moscow did refuse to give unsafeguard heavy water to India.

India is, however, seen here as the only non-nuclear country and certainly the only developing country that may already have crossed the threshold and acquired the ballistic missile capability. Experts here believe that India may not have yet developed a worthwhile guidance package that could give its missiles a dependable accuracy. India may, therefore, need further outside help and the western powers want to stop that.

A guidance system, by its very definition, guides a missile to its target. It is believed that the guidance system mounted on the U.S. missiles comprised 19,000 small and large components. Even if it were to be assumed that India has the capability to convert its peaceful satellite rocket into, an intermediate range ballistic missile, the western powers can still play a lot of mischief in putting hurdles in India's way.

Apart from India, a number of other countries (Israel, Egypt, Syria, Argentina, Brazil, Korea and Pakistan) are seen to be moving toward acquiring a ballistic missile-capability. Pakistan has not even started yet. Brazil received help from China and has made substantial progress. Israel received help from France. Argentina was helped by Italy and West Germany. Some of these countries have already acquired missiles but have not developed any credible capability to make missiles.

Though the United States and its allies will make a determined effort to impede India's progress in acquiring missile-related technologies, knowledgeable sources here believe that Americans will ultimately have to accept India as a missile-making power because India has already advanced too far ahead in this field.

Americans may persuade India to join the seven-nation agreement and to give an undertaking that it will not export its missile technology to other countries. China has already acquired not only a well-advanced nuclear weapons system but also a credible nuclear delivery system.

It was soon after the Indian nuclear test that the U.S. and its allies formed the suppliers' group to prevent export of nuclear materials and equipment going to the unsafeguarded facilities of non-nuclear countries like India. The strict export controls imposed by the nuclear suppliers' group impeded the progress of India's peaceful nuclear power development programme.

Now that India has succeeded in launching its own satellites, developing its own rockets and rocket fuel, the western countries are getting active again to prevent India from acquiring what China has acquired and developed a long time ago.

/9274

CSO: 5150/0135

BRIEFS

ATOMIC ENERGY BOARD--Bombay, 18 Jun--The safety review committee of the department of atomic energy has now become a part of the Atomic Energy Regulatory Board (AERB). This structural change has been made to enhance the powers and functions of the AERB. The AERB has been reconstituted and Prof A. K. De has been reappointed chairman. Other members of the AERB are: Prof K. Sri Ram, IIT, Bombay; Mr J. C. Shah, former chairman of the Atomic Power Authority and Gujarat State Electricity Board; and Dr P. B. Desai, director, Tata Memorial Centre. The chairman of the safety review committee will be an ex-officio member. Mr P. N. Krishnamoorthy continues to be the member-secretary of the board. [Text] [Bombay THE TIMES OF INDIA in English 19 Jun 87 p 3] /9274

CSO: 5150/0164

BRIEFS

YAQUB KHAN ON NUCLEAR-FREE ZONE--Pakistan has called upon the SAARC countries to evolve a regional dispensation with a solemn agreement to keep the region free of nuclear weapons. Addressing the SAARC ministerial meeting in New Delhi today, the foreign minister, Sahabzada Yaqub Khan, said Pakistan was ready to join in any such regional arrangements. He asked the SAARC countries to demonstrate that bilateral differences among them would not stand in the way of building a purposeful cooperation and that these differences will be resolved through peaceful means. [Text] [Karachi Domestic Service in English 1100 GMT 18 Jun 87 BK] /9274

CSO; 5100/4751

USSR CITES UK SOURCE ON PROGRESS OF PAKISTAN'S NUCLEAR PROGRAM

Moscow IZVESTIYA in Russian 15 Jul 87 p 5

[Article by A. Ostalskiy: "Operation 'Bomb'"]

[Text] In the photograph [not reproduced] which we are reprinting from the English journal SOUTH, the complex for enriching uranium, secretly built by Pakistan in the region of Kahuta, is pictured. It confirms what newspapers have been writing about for a long time: Islamabad has manufactured its first nuclear bomb and is now trying to create a whole nuclear arsenal.

As SOUTH reminds us, the Pakistan nuclear program came into existence in 1975, when the government of this country began to secretly buy components for constructing a uranium enrichment plant. Information was leaked to the press of many countries about the methods which the Pakistani leadership resorted to in order to circumvent the national and international means of control over the export of corresponding materials and components and to trick the International Agency of Atomic Energy, which was called upon to monitor the observance of the Treaty on Nuclear Nonproliferation.

Using all possible loopholes in the Western countries' system of export controls, Pakistani agents purchased materials and equipment which had both military and civilian uses. As a cover up, fictitious companies were created. Purchased "goods", for example, hollow steel spheres necessary for the body of an atomic bomb, were transhipped through third countries including Canada, Turkey and the Persian Gulf states.

In 1984 at a Texas airport, a Pakistani was arrested who was trying secretly to take out of the U.S. 50 highspeed electronic switches (krytrons) used in nuclear explosion devices. Letters discovered on him indicated his connections with official figures in the Pakistan nuclear industry.

SOUTH also reports that the American administration, supposedly concerned about Islamabad's nuclear preparations, sent almost 100 secret warnings about this to the other nuclear powers. But in such a case how does one evaluate the fact that Pakistan became in recent years one of the major recipients of American financial and military aid? After all, it is known that American legislation forbids granting such aid to countries illegally producing nuclear weapons or planning to create them.

The administration and Congress in fact are closing their eyes to the violation of the norms of international law and the laws of the United States itself in exchange for Islamabad's active participation in the undeclared war against Afghanistan and the allotment of bases to the dushman ringleaders by the Pakistani leadership.

CONVENTION ON PHYSICAL SAFE-KEEPING OF NUCLEAR MATERIALS

Moscow VEDOMOSTI VERKHOVNOGO SOVETA SOYUZA SOVETSKIKH SOTSIALISTICHESKIKH RESPUBLIK in Russian No 18, 6 May 87 PP 267-278

[Document published by the Supreme Soviet: "Convention on the Physical Security of Nuclear Materials"]

[Text] Section One

Convention on the Physical Security of Nuclear Materials

The countries subscribing to the convention,

- recognizing the right of all countries to develop and use atomic energy for peaceful purposes and their legitimate interest in obtaining the greatest benefit from the peaceful use of atomic energy,

- convinced of the need to foster international cooperation in the use of atomic energy for peaceful purposes,

- wishing to avert the potential danger that would result from the theft and use of nuclear materials,

- convinced that violations of the law represent cause for serious concern where nuclear materials are involved, and that there is an acute need to take appropriate and effective measures to prevent and disclose such violations and punish them,

- aware of the need for international cooperation to create effective nuclear materials security programs that will be in accordance with the laws of each country subscribing to the convention, and the convention,

- stressing in addition the importance of the physical security of nuclear materials when used, stored, and transported within a country,

- recognizing the importance of effective physical security for nuclear materials used for military purposes, and understanding that such materials are and will continue to be under strict physical security,

- agree to the following:

Article 1

For the purposes of this convention:

- a) "Nuclear materials" refers to plutonium, with the exception of plutonium containing more than 80 percent Pu238. It also refers to U233, uranium enriched with the isotopes U235 or U233, uranium containing a mixture of isotopes encountered naturally in a form distinct from ore or ore residue, and any materials containing one or more of the above-mentioned elements;
- b) "Uranium enriched with the isotopes U235 or U233" refers to uranium containing the isotopes U235 or U233, or both isotopes in such quantity that the percentage of these isotopes in a quantity of U238 is greater than the percentage of U235 in naturally occurring U238;
- c) "International transportation of nuclear materials" refers to shipments of nuclear materials by any means outside the territory of any country where the shipment originates. Transportation originates at the facility of the shipper in this country and terminates at the facility of the receiver in the end recipient country.

Article 2

1. This convention applies to nuclear materials used for peaceful purposes and in the process of being shipped internationally.
2. Except for articles 3 and 4 and paragraph 3 of article 5, this convention also applies to nuclear materials used for peaceful purposes when they are being used, stored, and shipped within a country.
3. Except for the obligations specially assumed by the states subscribing to the convention and stated in the articles, covered by paragraph 5, and pertaining to the use, storage, and transport of nuclear material to be used for peaceful purposes, nothing in this convention is to be interpreted as license to infringe the sovereign rights of countries as regards the use, storage, and transport of such nuclear materials within a country.

Article 3

In accordance with its own laws and international law, each state subscribing to the convention must take appropriate measures to ensure, to the greatest extent possible, that nuclear materials in the process of international transport and located within the borders of that country, or located on board ships or airplanes operating within the jurisdiction of that country, if such ships or airplanes are transporting nuclear materials to or from that country, be accorded one of the levels of security described in appendix 1.

Article 4

1. No country subscribing to the convention shall export or permit the export of nuclear materials if the country subscribing to the convention has not obtained a guarantee that during international transport such material will be accorded one of the levels of security described in appendix 1.

2. No country subscribing to the convention shall import or permit the import of nuclear materials from any country not subscribing to this convention, if the country subscribing to the convention has not obtained a guarantee that such materials will be accorded one of the levels of security described in appendix 1.

3. No country subscribing to the convention shall permit the transit of nuclear materials through its territory on land or internal waterways or through their air- or seaports between countries not subscribing to this convention unless such country has obtained a guarantee that during international transit, to the extent possible, such material will be accorded one of the levels of security described in appendix 1.

4. In accordance with its own laws, every country subscribing to the convention shall employ the levels of physical security described in appendix 1 for nuclear materials being transported from one part of that country to another along international waterways or in the air.

5. In accordance with paragraphs 1-3 above, a country subscribing to the convention and responsible for obtaining the guarantee that nuclear material will be accorded one of the levels of security described in appendix 1 must identify and notify in a timely fashion those countries across whose territory nuclear materials will be shipped by land or internal waterway, or into whose air- or seaports nuclear materials will enter.

6. Responsibility for obtaining the guarantees discussed in paragraph 1 may be transferred by mutual agreement to a country subscribing to the convention and involved in importing a shipment of nuclear material.

7. Nothing in this article is to be construed in any way as license to infringe the territorial sovereignty and jurisdiction of any country, including sovereignty and jurisdiction over its airspace and territorial waters.

Article 5

1. The countries subscribing to the convention shall identify the central agency and communications center responsible for physical security of nuclear materials, coordinated recovery measures, and response to illegal movement, use, or conversion of nuclear materials or the threat thereof, and inform each other if necessary either directly or through the International Atomic Energy Agency.

2. In case of loss of nuclear materials through theft, robbery, or other illegal seizure, or the threat thereof, the countries subscribing to the convention will cooperate in accordance with their laws to the maximum extent possible and assist any country that subscribes to the convention and requests assistance with the recovery and security of such nuclear materials. Specifically:

a. As quickly as possible, the country subscribing to the convention will take appropriate steps to inform other countries which, in its opinion, are affected by any loss of nuclear materials through theft, robbery, or other illegal seizure, or of the threat thereof, and, when necessary, notify international organizations;

b. When necessary, interested countries subscribing to the convention will exchange information with each other and international organizations in order to ensure the security of threatened nuclear materials, verify the integrity of shipping containers, and return illegally obtained nuclear materials, and:

- i. coordinate their efforts through diplomatic and other agreed-upon channels;
- ii. assist if requested to do so;
- iii. return nuclear materials stolen or lost as a result of the above.

The form such cooperation will take will be determined by the interested countries subscribing to the convention.

3. The countries subscribing to the convention will cooperate and consult with each other in the appropriate manner, either directly or through the International Atomic Energy Agency, to make recommendations about organizing, employing, and improving systems for physical security of nuclear materials during international transit.

Article 6

1. The countries subscribing to the convention will take steps that are consonant with their own laws to protect the secrecy of any information confidentially received from another country subscribing to the convention in response to the provisions of the convention, or obtained in the course of activity involved in implementing the convention. If the countries subscribing to the convention give information in confidence to international organizations, steps will be taken to ensure the secrecy of this information.

2. According to the terms of this convention, the countries subscribing to the convention are not required to give out information which their laws prohibit them from giving out, or which might jeopardize the security of the interested country or the physical security of nuclear materials.

Article 7

1. Any premeditated

a. acts such as obtaining, possessing, using, transferring, converting, destroying, or spraying nuclear materials, performed without the permission of competent authorities and entailing or potentially entailing the death or disabling of any person, or major damage to property;

b. theft or robbery of nuclear materials;

c. deceptive appropriation or acquisition of nuclear materials;

d. demands for nuclear materials based on the threat or actual use of force or other form of intimidation;

e. threats: i. to use nuclear materials to cause the death or disabling of any person, or major damage to property, or; ii. to commit one of the crimes indicated in subparagraph "b" with the intention of forcing a physical or juridical person, international organization, or country to act or refrain from acting in a certain way;

f. attempts to commit any of the crimes indicated in subparagraphs "a," "b," or "c;"

g. acts such as participation in one of the crimes indicated in subparagraphs "a"- "f,"

constitute a crime punishable by all countries subscribing to the convention in accordance with their laws.

2. In light of their seriousness, every country subscribing to the convention will take appropriate steps to punish the crimes listed in this article.

Article 8

1. Every country subscribing to the convention will take the steps that may be necessary to assert jurisdiction over the crimes indicated in article 7 in the following cases:

a. when the crime is committed in the country itself or on board a ship or airplane registered in that country;

b. when the suspected criminal is a citizen of that country.

2. Every country subscribing to the convention will also take whatever measures may be necessary to extend its jurisdiction to cover these crimes in cases where the suspected criminal is located in the country itself, and the country will not extradite him in accordance with article 11 to any of the countries indicated in paragraph 1.

3. This convention does not limit any criminal jurisdiction that is asserted in accordance with the laws of a given country.

4. In accordance with international law, and except for the countries subscribing to the convention indicated in paragraphs 1 and 2, a country subscribing to the convention may assert jurisdiction over the crimes enumerated in article 7 when such country is exporting or importing the nuclear materials.

Article 9

Once it is convinced that it has sufficient grounds for doing so, and in accordance with its own laws, any country subscribing to the convention and in which a suspected criminal is located must take appropriate steps, including keeping the suspect in custody, to ensure the suspect appears in court or is extradited. The countries that will be required to assert jurisdiction in accordance with article 8, and, when necessary, all other interested countries, should be informed without delay of the steps taken in accordance with this article.

Article 10

A country subscribing to the convention and in which a suspected criminal is located must, if it is not going to extradite him, convey him without exception and avoiding unnecessary delay to competent authority for criminal prosecution in accordance with the laws of the country.

Article 11

1. The crimes enumerated in article 7 are to be treated as crimes for which the offender is subject to extradition in accordance with existing extradition treaties between countries subscribing to the convention. It is mandatory for the countries subscribing to the convention to treat these crimes as extraditable in all future extradition treaties that may be concluded between them.

2. If a country subscribing to the convention and obliged by such a treaty to extradite a criminal is requested by another country subscribing to the convention but without an extradition treaty with the first country requiring it to extradite the criminal, it may if it wishes use the convention as the legal foundation on which to base extradition. Other legal provisions of the country receiving the request take precedence in such extradition cases.

3. Countries subscribing to the convention and not obliged by treaty to extradite a criminal will treat the crimes enumerated here as crimes subject to extradition and covered by the legal principles of the country receiving the request.

4. For the purposes of extradition between countries subscribing to the convention, every crime will be seen as a crime committed not only where it actually took place, but also in the countries subscribing to the convention

and requested to assert jurisdiction in accordance with paragraph 1 of article 8.

Article 12

Any person undergoing court examination for any of the crimes noted in article 7 is guaranteed fair treatment throughout the court examination.

Article 13

1. The countries subscribing to the convention will cooperate to the greatest extent possible with court examinations of crimes mentioned in article 7. This includes making all evidence at their disposal and necessary for the court examination available. In all cases, the laws of the country receiving the request for assistance are given precedence.

2. The provisions of paragraph 1 of this article do not affect obligations under any other bilateral or multilateral treaty which partially or completely governs or will govern mutual assistance in criminal cases.

Article 14

1. Every country subscribing to the convention will inform the depositories about those of its laws and decrees that affect implementation of this convention. The depository will periodically send this information to the countries subscribing to the convention.

2. The country subscribing to the convention and in which criminal charges against a suspected criminal have originated will inform interested countries of the final result of the court examination directly and in the shortest period of time possible. The country subscribing to the convention will also inform the depository of its final decision; the depository will inform the other countries subscribing to the convention.

3. If a crime concerns nuclear material used for peaceful purposes during its use, storage, or transport within a given country, and the suspected criminal and nuclear material remain inside the country subscribing to the convention and where the crime took place, nothing in this convention shall be construed as a requirement that a country subscribing to the convention provide information about the court examination of the crime.

Article 15

The appendixes are an essential part of this convention.

Article 16

1. Five years after the date this convention becomes effective, the depositories will convene a conference of the countries subscribing to the convention to review the extent to which the convention has been implemented and the degree to which its preamble, body, and appendixes are appropriate for the situation at that time.

2. Subsequently, a majority of the countries subscribing to the convention may call no more than one conference every five years for this purpose by appealing therefor to the depository.

Article 17

1. In the event of a disagreement between two or more of the countries subscribing to the convention about how to interpret or apply this convention, the countries subscribing to the convention will consult jointly to settle the dispute through negotiation or any other peaceful way of settling disputes that is acceptable to all parties to the dispute.

2. Any such dispute that cannot be settled using the techniques in paragraph 1 will, upon request of any party to the dispute, be dealt with by arbitration or the International Court of Justice. If arbitration is agreed upon as the technique for resolving the dispute and no decision can be made about the organization of the arbitration examination for six months from the date of the original request for arbitration, one of the parties may ask the president of the International Court of Justice or the secretary general of the United Nations to appoint one or more arbitrators. If the parties to the dispute have conflicting requests, the appeal to the UN secretary general has priority.

3. During the process of signing, ratifying, adopting or approving this convention or agreeing to observe it, any country subscribing to the convention may announce that it does not regard itself bound by the dispute settlement procedures prescribed in paragraph 2. Other countries subscribing to the convention are not bound by any dispute settlement procedure prescribed in paragraph 2 in areas where another country subscribing to the convention has put conditions on some aspect of the procedure.

4. Any country subscribing to the convention and putting conditions on the dispute settlement procedure in accordance with paragraph 3 may cancel the condition by informing the depository.

Article 18

1. Before becoming effective, this convention will be made available for signing by all countries at the central facilities of the International Atomic Energy Agency in Vienna and the central facilities of the United Nations in New York starting 3 Mar 1980.

2. This convention will have to be ratified, adopted, or approved by the countries that sign it.

3. After becoming effective, this convention will have open status to permit other countries to subscribe to it.

4. a. This convention may be signed by international organizations and integrated or other regional organizations, or such organizations may agree to observe it, as long as any such organization consists of sovereign states and

has the competence to conduct negotiations and conclude international agreements on issues dealt with in this convention.

b. When issues fall within their competence, these organizations will enforce the law and carry out the obligations assumed by the countries subscribing to the convention on their own behalf.

c. Once it subscribes to this convention, such an organization must send the depository a statement indicating what countries are members of the organization and which articles of this convention do not apply to them.

d. Such an organization does not possess a vote beyond the individual votes of its members.

5. Documents pertaining to ratification, adoption, approval, or agreement to observe the convention are to be given to the depository for safe-keeping.

Article 19

1. This convention becomes effective on the thirtieth day after the date the twenty-first ratification, adoption, or approval is submitted to the depository.

2. For every country that ratifies, adopts, approves, or agrees to observe this convention after the date the twenty-first ratification, adoption, or approval is submitted to the depository for safe-keeping, this convention becomes effective on the thirtieth day after said country turns in its ratification, adoption, approval, or agreement to observe the convention.

Article 20

1. Without prejudice to article 16, a country subscribing to the convention may propose amendments to this convention. Such amendments are submitted to the depository, which immediately distributes them to all countries subscribing to the convention. If a majority of the countries subscribing to the convention request a conference to review the proposed amendments, the depository will invite all the countries subscribing to the convention to the conference, which will start no sooner than thirty days after the invitation is sent. Any amendment adopted at the conference by a majority of two thirds of the countries subscribing to the convention will immediately be distributed by the depository to all the countries subscribing to the convention.

2. For every country subscribing to the convention, an amendment becomes effective on the thirtieth day after two thirds of the countries that will be submitting a ratification, adoption, or approval of the amendment actually submit their documents to the depository. Thereafter, the amendment becomes effective for every other country subscribing to the convention when such country turns in its ratification, adoption, or approval of the amendment.

Article 21

1. Every country subscribing to this convention may denounce the convention by notifying the depository in writing.
2. Denunciation of the convention becomes effective one hundred and eighty days after the date the depository receives the notification thereof.

Article 22

The depository will immediately notify all countries:

- a. each time this convention is signed;
- b. each time a ratification, adoption, approval, or agreement to observe the convention is received;
- c. each time a condition is put on or removed from the convention in accordance with article 17;
- d. of any statement sent by any organization in accordance with paragraph 4 "c" of article 18;
- e. when this convention becomes effective;
- f. when any amendment to this convention becomes effective;
- g. whenever this convention is denounced in accordance with article 21

Article 23

The original of this convention, whose versions in the English, Arabic, Spanish, Chinese, Russian, and French languages are all equally authentic, will be given for safe-keeping to the general director of the International Atomic Energy Agency, who will send notarized copies to all the countries.

In witness whereof, the appropriately empowered signatories affix their signatures to this convention made available for signature in Vienna and New York on 3 March 1980.

Appendix 1

THE LEVELS OF PHYSICAL SECURITY USED FOR INTERNATIONAL SHIPMENTS OF NUCLEAR MATERIALS CLASSIFIED IN APPENDIX 2

1. The levels of physical security for nuclear materials being stored prior to, during, or after international shipment include:
 - a. storage of category 3 materials in controlled access areas;
 - b. storage of category 2 materials in guarded or electronically monitored zones enclosed by a barrier with a limited number of entry checkpoints, or in any other zone with an equivalent level of physical security;
 - c. storage of category 1 materials in protected zones, as defined above for category 2 materials, to which access is granted only to persons of proven reliability, and which is under the permanent guard of a unit maintaining close contact with a response team. The purpose of any action that may be

taken is to discover and prevent any attack, unauthorized entry, or unauthorized removal of materials.

2. The levels of physical security for nuclear materials during international shipment include:

a. materials in categories 2 and 3 must be shipped in accordance with special precautionary measures, including prior contract between sender, shipper, and receiver, and prior agreement between the physical and juridical persons guided by the laws and under the jurisdiction of the importing and exporting countries. This agreement sets the time, place, and procedure for effecting the transfer of responsibility during shipment;

b. materials in category 1 must be shipped in accordance with the special precautionary measures outlined above for category 2 and 3 materials, and, additionally, must be kept under guard, with the guards maintaining close contact with response teams;

c. for shipments of more than 500 kilograms of natural uranium in a form distinct from ore or ore residue, security during shipment includes prior notification that the shipment will be taking place, with mode of transportation, expected time of arrival, and confirmation of receipt of shipment all indicated.

Appendix 2

TABLE: CLASSIFICATION OF NUCLEAR MATERIALS

Material	Form	Categories		
		1	2	3c
Plutonium (a)	Non-radioactive (b)	2 kg or more	less than 2 kg, but more than 500 g	500 g or less, but more than 15 g
Uranium235	Non-radioactive(b) -uranium enriched with 20 % or more U235	5 kg or more	less than 5 kg, but more than 1 kg	1 kg or less, but more than 15 g
	-uranium enriched with 10 to 20 % U235			less than 10 kg, but more than 1 kg
	-uranium more enriched than in natural state, but with less than 10 % U235			10 kg or more

Uranium233	Non-radioactive(b)	2 kg or more	less than 2 kg, but more than 500 g	500 g or less, but more than 15 g
Radioactive fuel			combined or natural uranium, thorium, or slightly enriched fuel (with less than 10 % fissionable isotopes)(d,e)	

-
- a. All plutonium, with the exception of plutonium containing more than 80 percent P238.
 - b. Material not irradiated in reactors, or material irradiated in reactors but at less than 100 rad/h at a distance of one meter unshielded.
 - c. Quantities not falling within category 3 and natural uranium should be safe-guarded as carefully as feasible.
 - d. Although this level of security is recommended, countries may specify a different level of security depending on the actual situation.
 - e. Other fuel which, depending on its original fissile material composition, was in categories 1 or 2 before it was irradiated, can be dropped no more than one category if the level of irradiation of the fuel was greater than 100 rad/h at a distance of one meter unshielded.

On behalf of the USSR, the USSR Presidium of the Supreme Soviet signed the convention on 22 May 1980 and ratified it on 4 May 1983, with the following condition accompanying the signature:

"The Union of Soviet Socialist Republics does not regard itself bound by the provisions of paragraph 2 of article 17 of the convention pertaining to the preferring of disputes to arbitration or the consideration of the International Court of Justice at the request of any of the parties to the dispute."

The USSR ratification was submitted to the general director of the International Atomic Energy Agency on 25 May 1983.

In accordance with article 19 of the convention, the convention became effective for the USSR on 8 February 1987.

13189
CSO: 1822/137

MOL NUCLEAR ENERGY CENTER INVOLVED IN PAKISTANI ATOMIC BOMB

Brussels LE VIF/L'EXPRESS in French 24/30 Apr 87 pp 10-19

[Article by Michel Balthasart: "Belgium's Strange Game--The Bomb for Islam"]

[Text] Is Belgium indirectly cooperating in manufacturing the Pakistani-Lybian atomic bomb, due to the thoughtlessness of the Nuclear Energy Center in Mol? Scientists say so. Are they completely wrong?

Pakistan, 23 March 1986. Was it possible that Severin Amelinckx, director general of the Nuclear Energy Research Center (CEN) in Mol, was unaware of the waspnest he was about to get into when he landed in Islamabad?

United States, 5 November 1986. Known all over the world for his investigation of the Watergate affair, WASHINGTON POST reporter Bob Woodward quoted a CIA report which showed "the dramatic progress" made by Pakistan in producing nuclear arms.

Belgium, 17 April 1987. A few steps away from the Mol Center located among the pines of the Campine moors, Martin Brabers, professor of metallurgy at the Catholic University of Louvain, officially denied the incendiary statements attributed to him by the British daily THE OBSERVER. However, Brabers is not unknown in Pakistan. In the late sixties he trained Dr Abdul Quadeer Khan in Belgium. From 1972 to 1975, this metallurgical engineer, born in 1936, worked for a Dutch company associated with the URENCO consortium, which at the time built the ultracentrifuge uranium enrichment plant at Almelo in the Netherlands. There Khan obtained ultra-confidential data on the enrichment process, data which he took back to Pakistan where, in all likelihood, he is currently running the military nuclear program.

In November 1986, Brabers, who has worked at the Nuclear Center in Mol, was invited to Pakistan by the University of Islamabad. There, according to THE OBSERVER, he met his former student who allowed him to visit the very secret Kahuta installations, where the Pakistani-Lybian bomb is undoubtedly being developed. Still according to THE OBSERVER, at the end of his visit (of which he provides details as a matter of fact), Brabers is said to have stated that henceforth Pakistan is capable of producing the bomb in a month.

Pakistani President Zia-ul-Haq commented to the HERALD TRIBUNE: "There is no need to quote a Belgian scientist for that. You may write that Pakistan is in a position to build a bomb whenever it wishes to do so. Once the technology has been acquired, you do whatever you want: use it for peaceful or military means."

Pakistan, the United States, Belgium: three locations on the axis around which revolves the "affair of the Pakistanis of Mol," which LE VIF/L'EXPRESS is revealing here. An affair which some people already consider "scandalous" and which poses the crucial problem of the development of nuclear technology in so-called "sensitive" countries. In Belgium today, scientists are protesting, the United States embassy is worrying, Philippe Maystadt, the minister of economic affairs, is wondering, and the Ministry of Foreign Affairs is entrenching itself behind respect for international commitments.

But before delving into the "confidential" documents of CEN, it is necessary to review history. In March 1946, the "Acheson-Lilienthal" Committee violently warned the world: "Nuclear energy developments for peaceful or military means are very interdependent or interchangeable. The only assurance we could have that nations or groups do not develop nuclear arms lies in the given word or the good faith of the party concerned."

A few months after Hiroshima, the great fear of nuclear proliferation spread over the whole planet. Very quickly, the USSR, Great Britain, France, and then China broke the American monopoly on the bomb, thus at the same time disrupting the relationship of the geopolitical forces. Since then, nuclear weapons candidates have been crowding at the gate. And today, many people feel that the "Islamic bomb" project, the fruit of the rivalry between India and Pakistan, constitutes one of the major risks of our times.

"At the center of this Muslim world, which stretches from Morocco to the furthestmost boundaries of Indonesia, and from the steppes of Central Asia to the equatorial forest of Africa," stressed Astrid Valois-Verone in the journal POLITIQUE INTERNATIONALE, "are a certain number of countries which, beyond the dream, are actively applying themselves to making nuclear arms available to them. When you know the names of some of their charismatic leaders--Colonel Qadhafi, the Ayatollah Khomeiny, General Zia-ul-Haq--you cannot doubt that if one day it is born, the Islamic bomb will be used."

In 1956, France and Israel at the same time embarked on the road of nuclear proliferation. In 1971, 24 years after the quasi-theological division of the Indian continent, the Islamic sub-empire of Pakistan exploded. In the East, the 80 million peasants of Bengal rebelled against the tutelage of Western Pakistan, led by the authorities in Islamabad. The Pakistani army of the West became bogged down in a savage repression of the East. Taking advantage of the unrest, New Delhi attacked and triumphed. In December 1971, Zulfikar Ali Bhutto took power in Rawalpindi. He had only one thought: revenge on New Delhi; one possible tool: the atomic bomb.

1956-1971: the dice have been thrown. Look at them roll. In January 1972, Bhutto gathered the elite among the Pakistani scientists at Multan and issued them a challenge: "Are you capable, in a few years time, to give Pakistan atomic weapons?" The response was positive. Money? Bhutto found it with Qadhafi, who was enthusiastic about the idea of an "Islamic bomb."

In the late sixties, Canada provided the basic tool: a heavy water and natural uranium nuclear reactor, set up in the suburbs of Karachi (Kanupp). Then began a long race for equipment, which Henri Eyraud and Michel Pochoy minutely described in the LE VIF/L'EXPRESS issue of 26 September 1986.

There are two main access roads to the bomb: plutonium "reprocessed" after leaving the reactor and uranium "enriched" to 93 percent into U-235 isotopes. Pakistan launched itself into both directions. Kanupp's reactors transform natural uranium into plutonium. Now this plutonium still had to be extracted from the used fuel. As of 1973, France provided a small pilot reprocessing plant. Bhutto entrusted most of the work to the Frenchmen, but he also called on Belgians from the Belgonuclear company. Located in Brussels, and then transferred to Paris, the Pakistani purchasing office of the famous Mr Putt acquired the necessary equipment. Thanks to the shrewd Abdul Quadeer Khan, Bhutto built the Kahuta project, a plant which produced uranium 235. Nobody is willing officially to provide the equipment? Who cares! "With the plans stolen from the Dutch," explained Valois-Verone, "the Pakistani engineers developed specifications for similar equipment, used in traditional chemical and electrical industries, thus sold without restriction."

Not Very Ordinary Mission

Today, the person in charge of Pakistan's nuclear program, Munir Khan, is a happy man: henceforth, the bomb is "within reach." Besides, Pakistan has at its disposal \$4 billion in American aid, of which 1.7 billion are military credits, distributed over 6 years. Since the invasion of Afghanistan, the Americans have been inclined to "close their eyes." Is Islamabad not their sole partner in the region? Do the American weapons supplied to the Afghan resistance not transit through Pakistan? General Zia, who is pursuing Bhutto's nuclear program, knows that he can make Washington pay dearly...

Valois-Verone's conclusion: "Hypocrisy or thoughtlessness? Lure of gain or irresponsibility? Few industrialized nations will escape the reproach of having been more or less directly the accomplices of this Islamic bomb."

At Gembloux, on 17 November 1986, speaking to an audience of dumbfounded invited guests, Dr Rene Constant, director general of the Institute for Radioelements (IRE), stated: "Belgium is not absent from this crazy game!"

As we mentioned above, a few months earlier the head of the Nuclear Center in Mol, Severin Amelinckx, accompanied by the assistant director, Paul Dejonghe, landed in Pakistan. Object of the trip: discussions about possible cooperation between CEN and the Pakistani Atomic Energy Commission (PAEC). After having outlined the general context of the country visited (urgent need for electricity, assistance from the United States, France and Germany, refusal to sign the non-proliferation treaty...), the mission report (document

PD/jhg-ZV.86.104 of 2 April 1986) specified that PAEC was clearly in favor of cooperation with Belgium: "A large number of important officials at PAEC were trained in Belgium (Free University of Brussels, Catholic University of Louvain, the Belgonuclear company, CEN, Belgatom). This spirit was confirmed by the Belgian ambassador in Islamabad. Hence, the proposal was made to reactivate the 1973 agreement between PAEC and the Belgian Atomic Energy Commissioner."

Emotion, Reservations, Protests

As a matter of fact, the welcome in Islamabad was so "extraordinarily cordial and efficient" that an agreement was signed between the parties: the Center in Mol will admit Pakistani trainees at the rate of "36 men/months" per year, or a maximum of 3 people simultaneously per year or 6 men for 6 months... The first two Pakistanis are expected to arrive in Mol next September. One of them will work on "mechanical tests on can sheaths," the other on "chemical analyses in the environmental field." However, in a chapter of the mission report entitled "General Impressions," Dejonghe noted that "prospects for cooperation with Belgium could be very good," but that, given the "special" situation of the country, "the restrictions on such cooperation should be profoundly evaluated."

Some officials on the board of directors in Mol have become nervous about the ties thus being developed with a "sensitive," internationally isolated (in theory only) country. Like Philippe Maystadt, the responsible minister, these officials are wondering, for example, whether it is normal for cooperation which carries such risks to be decided within the executive committee of the board of directors, while leaving the board as a whole ignorant of the affair. According to them, this decision should at least come under the responsible minister, if not the government as a whole.

"Several members of the board expressed serious reservations about the scientific cooperation on nuclear matters with Pakistan, even in non-sensitive areas," noted manager Luc Gillon, administrator of CEN. "We, on the board, feel that the political responsibility for the operation is incumbent upon the Ministry of Foreign Relations, which gave its approval. Of course, the trainees will not have any access to the plutonium technology."

For Dr Constant, also a CEN administrator, "it is true that, on paper, this concerns civilian programs, but we know to what extent the technologies interpenetrate one another and are in fact indissociable."

These "reservations" seem all the more justified as, according to information received, several of the people Amelinckx and Dejonghe met in Islamabad are directly involved in the Pakistani-Libyan military programs. That is the case, for example, of Ishfaq Ahmad, a top official of the "arms" group, and of A. Majid, technical director of the plutonium isolation technique for military needs. Strange for conversations related to civilian nuclear matters. Amelinckx's comment on this point: "I did not know that"...

Was the Belgian delegation "manipulated" then? One thing is certain: the fact that the Center in Mol has business dealings with Pakistan makes the situation even more delicate. On 10 November 1986, the Pakistani Atomic Energy Commission addressed a letter to CEN confirming Pakistan's interest in the Center's proposals concerning "the conception, development and supply of new instrumentation to replace the outdated one of the Kanupp nuclear power station in Karachi." In this letter, PAEC proposed that it make arrangements for a 2 week visit to Kanupp by two CEN experts. "During their stay, we will have detailed discussions of the program and of the duration of the work, of the training of our engineers and of the financial aspects, so that CEN can prepare a concrete offer."

As a matter of fact, those "good business relations" did not wait until December 1986 to manifest themselves. One month after the Amelinckx/Dejonghe mission, the director of the Belgonuclear company (a company with 50 percent participation by CEN) received a letter from the Pakistani Nuclear Science and Technology Institute (PINSTECH). "Encouraged by the recent visit of the director general of Mol," the director of this institute, Dr H.M.A Karim, asked the Belgonuclear company to make an offer in the area of the production of radio-isotopes.

Knowing the very exceptional situation of Pakistan, its propensity to develop industrial espionage activities, its needs in equipment and know how to perfect its military program and the hard line character of the Islamic regime, is it not dangerous to put oneself thus in a position of having to "please" in order to obtain certain commercial contracts? How far is Belgium willing to be led in order to sell its merchandise? What guarantee can we have that its representatives will never go "a little too far"?

Simple Matter of Trade?

One should be aware that, in the recent past, the Center in Mol has sent experts to Qadhafi in Libya. It has also received Libyan and Iranian trainees. At the time, manager Gillon protested energetically. "The argument used to send scientists to Libya was unacceptable," he said. "It was largely due to the influence of the Belgonuclear company which tries to do business by all means. At the time, a personal friendship existed between the firm's former assistant manager and a Libyan individual." The Libyan adventure of the Belgonuclear company, to which the United States put an end in 1984, has already caused much ink to flow. But the Belgian firm also intervened in Pakistan. On 28 July 1975, the Quai d'Orsay (French Department of Foreign Relations) addressed a telex to the French ambassador in Brussels. According to the Quai d'Orsay, Munir Khan stated in Paris that "thanks to the pilot industry built with the aid of the Belgonuclear company, Pakistan is capable of manufacturing the plutonium necessary for an explosive device." About 4 or 5 years ago, the Belgonuclear company trained Pakistani engineers "in the operation and maintenance of nuclear power stations."

On 31 January 1987, Herman De Croo, Belgian minister of foreign trade, arrived in Pakistan in the company of representatives of a few corporations. Among them the inevitable arms salesman ASCO, ACEC and... Belgatom (80 percent Tractebel and 20 percent Belgonuclear company). The latter's objective: to bring back a contract to update the Kanupp reactor. ACEC itself was authorized to respond to a request for offers to replace and modernize the equipment and control of the Kanupp power station. Following years of indifference, Belgium is suddenly very interested in Pakistan indeed. "For us," explained Edy Jonckheere, trade director for the Belgonuclear company, "there is no obvious connection between civilian and military nuclear matters. From that point of view, our company cannot be accused of anything."

Amelinckx' version of CEN's relations with Pakistan is edifying: "I have no reason at all to hide anything," he said. "We have had a cooperation agreement with Pakistan since 1963. For several years we have received Pakistani and Indian trainees. In 1974, India exploded a bomb and we distanced ourselves from both countries. In October 1985, at the request of the cabinet of Etienne Knoops--the then secretary of state for Energy--I received the visit of Dr Munir Khan. The latter had previously gone to the Ministry of Foreign Relations to request Belgian aid in matters of civilian nuclear energy. Provided with those references, Khan was able to visit the Center in Mol and he invited us to Pakistan. In this field, the establishment of trade relations inevitably involves the training of trainees. And we feel that it is CEN's role, if not its obligation to develop such relations for our industry."

According to Amelinckx, the executive committee of the board of directors was empowered to authorize such a mission. The reservations expressed by some board members and the remarks made by Miss Herpels, head of the scientific section in the Ministry of Foreign Affairs, were taken into account."

Amelinckx added that "the trainees will work in completely innocent areas. As a matter of fact, CEN no longer has a "sensitive" sector because the plutonium laboratory has been closed."

Recalling the American aid to Pakistan, Amelinckx accused his detractors of "comparing crumbs and mountains." The Mol chief stressed that Kanupp is subject to control by the International Atomic Energy Commission (IAEC). "I would note," he concluded, "that we are masochistic to the point of sabotaging ourselves. How can you maintain trade relations under those circumstances? In Belgium, as soon as you send 10 cartridges somewhere, the press protests, whereas tons of ammunition are supplied by the big countries."

In short, since the others are doing it, why not us? Some people however are wondering whether this "pragmatism" is acceptable when it comes to helping "unpredictable" regimes getting access to a degree of technology which puts nuclear weapons within their reach. Let us recall that several Belgian scientists maintain that in nuclear matters "nothing is innocent." On this basis, the presence of CEN at the sides of Qadhafi, of the Ayatollah Khomeiny and of General Zia seems indefensible.

The letter concerning Belgium's international commitments is of course respected. But what about the spirit? Questioned by Maystadt, Leo Tindemans emphasized "that the policy we are conducting with regard to Pakistan is aimed at not breaking all nuclear cooperation ties with that country, in order to be able to exercise some control and to have privileged information about Pakistan's activities in nuclear matters." Three sectors are excluded from relations with General Zia's regime: reprocessing, enrichment and plutonium activities.

In a memorandum addressed to the director general of Foreign Relations policy, Miss Herpels noted however that the Amelinckx/Dejonghe mission report and the draft agreement with PAEC "has brought out a number of worrisome elements in that they reflect a lack of understanding of the real situation in Pakistan with regard to IAEA control and of the possible future effects which some areas of cooperation being considered could have on our relations with the United States." It is true that corrections have been made, but it must be acknowledged that the "lack of understanding" exhibited by the management of Mol in this instant is not very reassuring.

Very recently, seven industrialized nations (France, the FRG, Great Britain, Canada, Japan, Italy and the United States) decided to adopt measures aimed at limiting the sale to Third World countries of equipment and technology which would make the production of nuclear missiles possible.

"In truth," stressed Constant, "international competition and racketeering have always existed in the matter and the constraints of the treaties have been regularly violated, in spite of the risks involved. Let us be clear: a compromise is virtually impossible in this area where the slightest transactions amount to billions of Belgian francs, if not billions of dollars. To believe anything else would be naive."

Today, stressed Astrid Valois-Verone, the United States is embarrassed because of Pakistan. Their hesitation waltz has led them to what they were afraid of: the birth in the world, not of a new nuclear power--it takes much more than one bomb to form a weapons system--but of a new nuclear detonator. Is not the time of economic pressures past? After all, if Pakistan were driven to the edge of bankruptcy perhaps it would be tempted, for a few billion dollars, to sell its nuclear fire to Khomeini or Qadhafi.

The file concerning the Pakistani trainees at Mol is currently in the hands of officials of the Nuclear Security Agency, a service which comes under the Ministry of Justice. Up to now, this service has not had to officially investigate CERN's mission in Pakistan. It still has the possibility to refuse permission for the arrival of the Pakistanis. The question is whether the Center in Mol is sufficiently "armed" to resist all the temptations, in spite of the importance of the commercial stakes. When you eat with the devil, the proverb says, you need a long, a very long spoon!

8463

CSO: 5100/2452

SEARCH FOR NUCLEAR WASTE ROCK-BURIAL SITE BEGINS

Helsinki HELSINGIN SANOMAT in Finnish 9 Apr 87 p 10

[Article: "TVO Begins Test Drilling in Bedrock; Five Localities Chosen As Candidates for Permanent Storage of Nuclear Waste"]

[Text] Eurajoki (HS)--The Industrial Power Company (TVO) is initiating rock studies in five localities for a permanent storage site for nuclear waste. Bedrock studies will begin within the next few weeks at Hyrynsalmi and Kuhmo. Drilling will begin next year at Konginkangas, Eurajoki and Sievi. A permanent burial site for the uranium fuel that has been accumulating at the Olkiluoto nuclear power plants is being sought through these studies.

It is estimated that 1,300 tons of nuclear waste, about 60 to 70 truckloads, will have accumulated at the Olkiluoto nuclear power plants during the 30 years they are in operation.

They also plan to study the rock formations near the nuclear power plants at Olkiluoto and Eurajoki. TVO assistant general manager Esko Haapala said that all the test sites will be included on an equal basis when they look for a permanent storage site. Out of 85 communities 5 were chosen, especially because, according to Haapala, they were prepared to accept execution of the studies.

The land ownership situation also influenced the choice of sites. At Olkiluoto the study site is already in part owned by the power company, whereas in the other localities the Forest Ministry owns the land the study sites are on. From five to ten sites a square kilometer in size have been set aside in connection with the studies for a permanent disposal site for nuclear waste.

Veitsivaara near Hyrynsalmi, Kivijarvenkangas near Sievi and Kivetty near Konginkangas are granite sites. Romuvaara near Kuhmo is the oldest rock formation in Finland, 3-billion-year-old bottom gneiss. At Olkiluoto the rock bed is mixed stone.

"The advantage at Olkiluoto is, of course, the short distance from the power plants. Here we have the best basic prior conditions for the final handling and encapsulation of the fuel," Haapala said.

At each study site the surface will first be surveyed and mapped. After that a hole from 500 to 1,000 meters deep will be drilled at the site and the structure of the bedrock and the ground water situation studied through it. In addition, shallower holes will be drilled, from 300 to 500 meters in depth. A couple of years will be spent in studying a site. The results on all the sites must be ready by 1992.

Permanent Disposal Site Will Be Selected by the Year 2000

Engineer Hannu Harkonen of the TVO Nuclear Waste Office said that the hardness of the bedrock and the nature, volume and movements of the ground water will be determined in these studies as well as the stability of the bedrock. The studies will provide employment for several people at each locality.

During the second half of the next decade they will use a couple of sites for detailed studies and they plan to select the ultimate storage site for the nuclear waste by the year 2000.

Rods to a Depth of Half a Kilometer

According to Harkonen, the possibility of exporting the nuclear waste will be investigated, but if nothing comes of it, construction of the storage cave will begin in 2010. It is estimated that the Olkiluoto nuclear power plants have an operational life of from 30 to 40 years and the permanent storage facility must be ready by 2020.

They plan to bury the uranium rods dipped in copper at a depth of half a kilometer. It is estimated that it will cost over 2 billion to store the spent fuel and the TVO will be collecting the funds for it at the rate of a penny for every kilowatt hour generated.

The rock studies that are now being initiated will cost from 8 to 10 million per site and it is estimated that a total of about 100 million will be spent on the rock studies.

While waiting for the permanent storage facility for the fuel waste that is accumulating at the power plants, the uranium rods will be temporarily stored at Olkiluoto. According to Municipal Council chairman Pasi Jaakkola, Eurajoki has at this point merely taken note of the nuclear power company's announcement that it is planning to choose Olkiluoto as one of the test sites for a permanent storage facility. Eurajoki has, however, adopted a negative stance in its municipal plan on the location of a permanent storage facility for nuclear waste on a town site.

Towns View Project in Unbiased Manner

The communities of Sievi and Hyrynsalmi and the town of Kuhmo appear to be accepting the TVO's search for a burial site for nuclear waste in an unbiased manner. At present only the intermediate laps are in progress. Let's wait and see which townships make it into the final lap, the town fathers are calmly thinking.

Local officials in Sievi expect them to find more ore during their bedrock studies than solid bedrock. They hope that Kivijärvenkangas will turn out to be part of the ore-critical area between Ladoga and the Gulf of Bothnia. The Outokumpu Company's mine at Kitura is a few dozen kilometers away. In March the Sievi Municipal Board unanimously approved admission of the TVO drillers. At the time they did not adopt a position on the permanent disposal site.

"The community still has a strong say in the matter before a plant can be built in its district. According to the nuclear energy law which is coming up for discussion in Parliament again, Parliament cannot make a decision on a site without the consent of the local community," town manager Risto Haikola reminded them.

"Benefits Cannot Be Underestimated"

The town fathers of Hyrynsalmi did not oppose a study of 2.5-billion-year-old Veitsivaara either. "The site is a deep wilderness. The Forest Ministry owns it. The law says that they may drill with the landowner's permission. The Forest Ministry has approved the project," town manager Kari Ahokas said.

"The nuclear waste problem is the common business of all Finns. It is not merely a question of social attitude if we may get paid a couple of billion, 100 people get jobs and we get a plant that will operate for 60 years," Ahokas reasoned.

One out of every five adults is unemployed in Hyrynsalmi. The town's own income and expenditures budget is roughly 75 million markkas. "If we win the final competition, the benefits cannot be underestimated."

Kuhmo municipal secretary Jorma Karjalainen stressed the fact that the town would not be tying its hands in any way in allowing geologists to study Romuvaara. Right near the border, the hill is the oldest in Finland, bedrock that may even be as old as 4.5 billion years.

Like Kuhmo, Sievi and Hyrynsalmi make it a condition in their decisions that joint committees be formed composed of TVO and local representatives. They also require that local residents be employed in research operations insofar as is possible.

First Holes to Be Drilled in Rock This Summer

The TVO is starting out very cautiously and emphasizing a spirit of open information. As early as Wednesday, the company's public relations people began to set up an exhibit in Sievi's town hall explaining how the rock will be drilled. For a week residents of Sievi will be able to go and wangle information out of TVO exhibitors.

The TVO will be setting up bases of operation in Kuhmo and Hyrynsalmi as soon as next week. The geologists will at first start to take magnetic and radar-wave measurements during the next few weeks. At the end of the summer the drilling rigs will bore the first holes to a depth of a kilometer. There will still be time for them to take water samples from them before winter sets in.

Konginkangas Is Excited

In a year from now geologists will bring to the Kivetty rock formation near Konginkangas an 8-ton drilling rig by means of which they will drill holes into the 1.5-million-year-old porphyritic granite rock.

The 1,600 residents of Konginkangas in North Central Finland are waiting for the TVO's arrival in the town in a state of excitement. They do not yet dare to shout with joy, but if the power company chooses Konginkangas as a permanent site for the disposal of its nuclear fuel, life in the town will noticeably change.

Struggling in the grip of an unemployment rate of about 13 percent, the town cannot boast of having any big industrial firms or of being one of the famous tourist resorts. It has been left in oblivion to the east of Highway No 4. Even its own residents go to work mainly in Aankoski and Suolahti.

The biggest employer is the town itself. It pays a salary to about 150 people. The second biggest, a textile company, employs about 20 people.

Town manager Pertti Lemettinen and Municipal Board chairman Niilo Kytonen asserted that both the townspeople and the town's appointed representative bodies take a favorable view of the nuclear burial study.

The Foreign Ministry owns the land Konginkangas' Kivetty is on. The company is mapping a site 3 to 4 square kilometers in size. Originally, a slightly larger piece of land was set aside, but the Environment Ministry reduced it because of a nearby nature sanctuary. The distance from the closest inhabited area amounts to 5 km.

While field studies per se will not begin at Konginkangas before another year, project head Esko Peltonen of the TVO hopes that the company will as early as next fall lease from abroad a helicopter specially designed for scientific research for the measurement of electromagnetic fields and nature's own radiation, among other things.

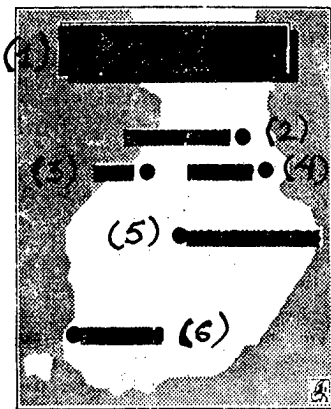

Key:

1. TVO rock studies.
2. Hyrynsalmi.
3. Sievi.
4. Kuhmo.
5. Konginkangas.
6. Eurajoki.

11,466

CSO: 5100/2437

FRANCE

WEST EUROPE

BRIEFS

NUCLEAR PLANT SODIUM LEAK--Paris--The French "Superphenix" nuclear power plant has suffered another leak in a sodium tank. About 800 liters of the liquid metal leaked through the hole into a collecting basin. Sodium is extremely volatile: It burns on contact with air and explodes on contact with water. The head of the operating company said that there is no danger to the population. Prime Minister Chirac stated that he was being kept informed about the incident at all times. [Text] [Vienna ORF Teletext in German 0710 GMT 29 Jun 87] /8309

RADIOACTIVE LEAK FROM NUCLEAR PLANT--There was a leak of radioactive carbon dioxide yesterday at the St Laurent-des-Eaux nuclear power plant, in the Loire-et-Cher Department. The leak, which occurred during a deliberate shutdown of one of the power plant's reactors, lasted for 7 minutes. Some 450 cubic metres of carbon dioxide were released in the atmosphere. According to the authorities this had no effect on the environment. The causes of the accident are now under investigation. [Text] [Paris Domestic Service in French 2100 GMT 6 Jul 87 LD] /9274

CSO: 5100/2456

TEA GROWERS TOLD TO KEEP HARVESTS SEPARATE

Istanbul TERCUMAN in Turkish 22 Apr 87 p 3

[Article by Emin Pazarci: "Don't Mix 1987 Tea With Other Tea"]

[Text] Ankara (TERCUMAN)--Upon the recommendation of the Turkish Atomic Energy Commission Directorate, Ministry of Industry and Trade Cahit Aral sent a circular to the management of the Tea Growers Organization asking that the 1987 tea crop not be mixed with previous crops. In the instructions sent to the Tea Growers Organization, Aral requested that packages containing the 1987 tea crop be specifically labeled as such.

It was learned that the Turkish Atomic Energy Commission is conducting extensive research in the Eastern Black Sea region in connection with the 1987 tea crop. It was announced that the Commission has an eight-man team, two of whom are stationary, which is continuously combing the region and that the new crop has been under observation since its flowering stage. At the same time, it was stated that if high ratios of radiation were found in the 1987 tea crop, it would be destroyed without mixing it with other crops.

No Danger

Meanwhile, Associate Professor Dr Atilla Ozmen, appointed acting chairman of the Turkish Atomic Energy Commission, said that after the Chernobyl tragedy, research conducted in Europe, outside of the USSR, found levels of radiation not to be high enough to threaten human health. Ozmen said the same results were found in research conducted in Sweden, one of the nations least affected by the radiation leak at the Chernobyl Nuclear Plant.

Birth Defects Investigated

Responding to a question from TERCUMAN correspondent, Ozmen said that the German claims of "increase in birth defects after the Chernobyl incident, especially in the Duzce region" are being fastidiously examined and further stated:

"We are conducting research not only in that region but in all of Turkey. We requested statistical reports on birth defects from the Ministry of Health and

Social Assistance. From the initial reports, we established that out of 1,000 births last year, 200 had birth defects. However, this figure is not above previous years' statistics. Furthermore, establishing a relationship between radiation and birth defects is very hard. Despite this, our studies are continuing."

12816/6662
CSO: 5100/2444

TURKEY

WEST EUROPE

BRIEFS

RADIATION CHECKS--Ankara (MEDITERRANEAN NEWS AGENCY)--Starting in the summer months, individuals who want to will be able to get a radiation count of their bodies in Ankara and Istanbul for a reasonable price. Contracts have been made for the Turkish Atomic Energy Commission to import instruments that measure amounts of radiation naturally found in the human body or transmitted by different foodstuffs or by other sources. It was stated that citizens who want to, can take advantage of these instruments, which will be installed at the Turkish Atomic Energy Commission's stations in Ankara and Kucukcekmece, Istanbul, and get radiation counts of their bodies on the condition that they pay a reasonable fee. [Text] [Istanbul TERCUMAN in Turkish 9 Apr 87 p 3] 12816/6662

USSR PURCHASE OF RADIOACTIVE HAZELNUTS--Giresun--FISKOBIRLIK [Hazelnut Agricultural Sales Cooperatives Union] signed a contract to export 3,000 more tons of shelled hazelnuts to the Soviet Union. Deputy General Director Ulku Nefesoglu told an ANATOLIAN AGENCY correspondent that agreement had been reached with the firm Vostokontorg to sell 3,000 tons of shelled hazelnuts with a radiation count above 600 becquerels for \$311.50 per 100 kilograms. Nefesoglu said that 7,605 tons of shelled hazelnuts had already been sold to the Soviet Union and that this contract would make it a total of 10,605 tons of radiation contaminated hazelnuts sold to the Soviet Union this year. He said that FISKOBIRLIK has sold 57,827 tons of hazelnuts in all this year and has only 1,200 tons of shelled nuts left on hand. Noting that 14 billion liras in supplementary payments have been paid to growers so far, Nefesoglu added that 5 billion liras more will go to growers in supplementary payments. [Text] [Istanbul GUNAYDIN in Turkish 20 May 87 p 4] 8349

CSO: 5100/2453

END

10

This is a U.S. Government publication. Its contents in no way represent the policies, views, or attitudes of the U.S. Government. Users of this publication may cite FBIS or JPRS provided they do so in a manner clearly identifying them as the secondary source.

Foreign Broadcast Information Service (FBIS) and Joint Publications Research Service (JPRS) publications contain political, economic, military, and sociological news, commentary, and other information, as well as scientific and technical data and reports. All information has been obtained from foreign radio and television broadcasts, news agency transmissions, newspapers, books, and periodicals. Items generally are processed from the first or best available source; it should not be inferred that they have been disseminated only in the medium, in the language, or to the area indicated. Items from foreign language sources are translated. Those from English-language sources are transcribed, with the original phrasing and other characteristics retained.

Headlines, editorial reports, and material enclosed in brackets [] are supplied by FBIS/JPRS. Processing indicators such as [Text] or [Excerpts] in the first line of each item indicate how the information was processed from the original. Unfamiliar names which are rendered phonetically or transliterated by FBIS/JPRS are enclosed in parentheses. Words or names preceded by a question mark and enclosed in parentheses were not clear from the original source but have been supplied as appropriate to the context. Other unattributed parenthetical notes within the body of an item originate with the source. Times within items are as given by the source.

SUBSCRIPTION/PROCUREMENT INFORMATION

The FBIS DAILY REPORT contains current news and information and is published Monday through Friday in 8 volumes: China, East Europe, Soviet Union, East Asia, Near East & South Asia, Africa (Sub-Sahara), Latin America, and West Europe. Supplements to the DAILY REPORTs may also be available periodically and will be distributed to regular DAILY REPORT subscribers. JPRS publications generally contain less time-sensitive information and are published periodically. Current JPRS publications are listed in *Government Reports Announcements* issued semi-monthly by the National Technical Information Service (NTIS), 5285 Port Royal Road, Springfield, Virginia 22161 and the *Monthly Catalog of U.S. Government Publications* issued by the Superintendent of Documents, U.S. Government Printing Office, Washington, D.C. 20402.

U.S. Government offices may obtain subscriptions to the DAILY REPORTs or JPRS publications (hardcovers or microfiche) at no charge through their sponsoring organizations. DOD consumers are required to submit requests through appropriate

command validation channels to DIA, RTS-2C, Washington, D.C. 20301. (Telephone: (202) 373-3771, Autovon: 243-3771.) For additional information or assistance, call FBIS, (703) 527-2368, or write to P.O. Box 2604, Washington, D.C. 20013.

The public may subscribe to either hardcover or microfiche versions of the DAILY REPORTs and JPRS publications through NTIS at the above address or by calling (703) 487-4630. Subscription rates will be provided by NTIS upon request. Subscriptions are available outside the United States from NTIS or appointed foreign dealers. Back issues or single copies of the DAILY REPORTs and JPRS publications are not available. New subscribers should expect a 30-day delay in receipt of the first issue.

Both the DAILY REPORTs and the JPRS publications are on file for public reference at the Library of Congress and at many Federal Depository Libraries. Reference copies may also be seen at many public and university libraries throughout the United States.