



**FOREIGN
BROADCAST
INFORMATION
SERVICE**

19981104 108

JPRS Report

Science & Technology

Europe & Latin America

DISTRIBUTION STATEMENT A

Approved for public release;
Distribution Unlimited

DTIC QUALITY INSPECTED 2

REPRODUCED BY
U.S. DEPARTMENT OF COMMERCE
NATIONAL TECHNICAL
INFORMATION SERVICE
SPRINGFIELD, VA 22161

25
98
A05

22 JUNE 1987

SCIENCE & TECHNOLOGY
EUROPE & LATIN AMERICA

CONTENTS

WEST EUROPE

SCIENTIFIC, INDUSTRIAL POLICY

Effects of EC R&D Budget Dispute on Esprit, Race, Brite Progress (Nicole Le Guennec; INDUSTRIES & TECHNIQUES, 20 Mar 87) .	1
CIPI Approves Italian Industrial R&D Project Funds (GAZZETTA UFFICIALE DELLA REPUBBLICA ITALIANA, 12 May 87).	7
EC Commission Proposes Funding for Business-Innovation Centers (TECHNOLOGIE NACHRICHTEN-MANAGEMENT INFORMATIONEN, No 451, 16 Mar 87)	10

EAST EUROPE

AEROSPACE, CIVIL AVIATION

GDR Contribution to Interkosmos Program (ASTRONOMIE UND RAUMFAHRT, No 1, 1987)	12
Development, Prospects of Romanian Aircraft Industry (Ion Petroaica; REVISTA ECONOMICA, No 52, 26 Dec 86)	17

BIOTECHNOLOGY

Hungary: Trends, Achievements in Biotechnology Noted (Istvan Palugyai; HETI VILAGGAZDASAG, No 7, 14 Feb 87) ..	23
---	----

COMPUTERS

Hungary: Allocation of Resources Disappoints Some Sectors (COMPUTERWORLD/SZAMITASTECHNIKA, No 5, 11 Mar 87)	27
Hungary: PerComp, Major Player in PPC Field (COMPUTERWORLD/SZAMITASTECHNIKA, No 5, 11 Mar 87)	28
Hungary: Superior Teleprocessing Control (COMPUTERWORLD/SZAMITASTECHNIKA, No 5, 11 Mar 87)	30
Hungary: Agricultural Computer Association (COMPUTERWORLD/SZAMITASTECHNIKA, No 5, 11 Mar 87)	31
Hungary: Competition To Promote Electronification Announced (COMPUTERWORLD/SZAMITASTECHNIKA, No 5, 11 Mar 87)	33
Hungary: Domestic Commodore-64 Peer Needed (COMPUTERWORLD/SZAMITASTECHNIKA, No 5, 11 Mar 87)	34
Hungary: Coblab, New Videoton Software Evaluated (COMPUTERWORLD/SZAMITASTECHNIKA, No 5, 11 Mar 87)	36
Hungary: Links Between Agriculture, Computer Technology Needed (Gitta Takacs; COMPUTERWORLD/SZAMITASTECHNIKA, No 5, 11 Mar 87)	40
Olivettis With Hungarian Character Keyboards Purchased (COMPUTERWORLD/SZAMITASTECHNIKA, No 7, 8 Apr 87)	44
Science Park at Budapest University (COMPUTERWORLD/SZAMITASTECHNIKA, No 7, 8 Apr 87)	45
Hungary: Latest Videoton Printer (COMPUTERWORLD/SZAMITASTECHNIKA, No 7, 8 Apr 87)	49
Data on Romanian Computers Amended (Zoltan Biro; COMPUTERWORLD/SZAMITASTECHNIKA, No 7, 8 Apr 87)	50
Hungary: Csepel Computer Here To Stay (Janos Andor Vertes; COMPUTERWORLD/SZAMITASTECHNIKA, No 7, 8 Apr 87)	51
Hungary: Small Coop Plans Large Series Computer Production (COMPUTERWORLD/SZAMITASTECHNIKA, No 7, 8 Apr 87)	55
Hungary: Interview on Future of Online Databases (Peter Jacso Interview; COMPUTERWORLD/SZAMITASTECHNIKA, No 7, 8 Apr 87)	59

Hungary: Expert Systems and Artificial Intelligence (COMPUTERWORLD/SZAMITASTECHNIKA, No 7, 8 Apr 87)	62
General Overview	62
Machine Industry Applications	62
Developments in MPROLOG	63
Council Administrative System	64
 Hungarian, Socialist Computer Market in 1986 (Peter Broczko; COMPUTERWORLD/SZAMITASTECHNIKA, No 7, 8 Apr 87)	 66
 Hungary: Model Computer Integrated Manufacturing System (Janos Kis; UJ IMPULZUS, No 8, 18 Apr 87)	 76
 FACTORY AUTOMATION, ROBOTICS	
 Progress of Automation in Czechoslovakia (Bedrich Cudlik; PRZEGLAD TECHNICZNY, No 48-49, 30 Nov-7 Dec 86)	 79
 MICROELECTRONICS	
 Hungary: Microelectronics Enterprise Remains Active Despite Fire (Laszlo Gergely; MAGYAR NEMZET, 13 May 87)	 83
 Development of Electronics in Romania (Octavian Juncu; REVISTA ECONOMICA, No 52, 26 Dec 86) ..	 87
 LATIN AMERICA	
 COMPUTERS	
 Brazilian Computer Technology (GAZETA MERCANTIL, 16 Mar 87)	 93

/7310

EFFECTS OF EC R&D BUDGET DISPUTE ON ESPRIT, RACE, BRITE PROGRESS

Paris INDUSTRIES & TECHNIQUES in French 20 Mar 87 pp 83-91

[Article by Nicole Le Guennec: "A Mix of Men and Ideas"]

[Excerpts] Esprit proved it: the collaboration of competing European companies in a joint research program is not only possible but even salutary. It is the starting point of a real mix of men, ideas and expertise conducive to agreements and exchanges; it also means the establishment of European standards essential for opening up the huge European market. Moreover, it is unquestionably one way of rising to the American and Japanese challenge. Other programs were spawned: Brite, Race, Comett, etc. But all of this may be jeopardized by the refusal of Great Britain, Germany and France to fund a 5-year master program.

"There can be no question of selling European research for a song. The commission must do something serious or nothing at all! It is the technological future of Europe that's at stake," pleads Michel Carpentier, general director of the EEC's DG XIII. The rejection by the three great powers, Great Britain, Germany and France, of an overall package of 7.7 billion ECUS for a 5-year research program is at the root of this disagreement (1 ECU=6.9 francs). Yet it is a very modest sum. "If you subtract the portion allocated to research centers, it is only 6.6 billion ECUS for 5 years," Michel Carpentier goes on to say. "1.3 billion ECUS per year is equivalent to 13 days of the Community's budget, a lower cost than the charges for stocking agricultural products!"

The 7.7 billion ECU'S is not more than 3.5 percent of the total Community budget for an equivalent period; barely 5 percent of the agricultural budget and less than 2 percent of the slated R&D expenditures of the 12 EEC countries! At a time when all research and development budgets are thriving, Michel Carpentier is hopeful that he will be able to generate recognition of the need for a European research program and convince hostile governments of the necessity of a funding package that is not forever dwindling. "We are prepared to negotiate the content of the program and make some adjustments, but we are not prepared to accept a comprehensive package of less than 3 billion ECUS for a 5-year period!"

A suspension or a sharp decline in Community aid just when real cooperation is beginning to take shape and the first positive effects are materializing would quickly jeopardize everything. The participants, industrialists, SSII, study centers and project managers are convinced of it. This type of pre-competitive research among competing companies, although highly productive, goes against the grain. "It is done and only can be done by applying a little financial balm," asserts Pierre Lepetit, Thomson's technological cooperation director.

In fact, a freeze has been in effect since the beginning of the year, when the master-program was blocked. The first phase of Esprit is continuing on its course. Of the 750 million ECU'S (the Community's share), FR500 million have been committed; the remainder will be allocated between now and the end of 1988 to selected contracts. On the other hand, the notices soliciting bids for the second phase of the program, which should have been published at this time, cannot be until the master-program or a compromise is accepted and the Esprit 2 budget is voted. At best, this will happen by next fall, with projects commencing at the beginning of 1988. As for the Race program, we will have to wait. The design phase was completed at the end of 1986. The estimated research budget of 800 million ECUS is of course blocked and no bids are being called for. It's the same story for Euram, a more modest program of 30 million ECUS devoted to materials research and for Delta, which was to have studied and developed training technology. Only Brite and Comett, which do not fall under the master program, are less affected by the blockage of funds, but are nevertheless suffering the consequences of the uncertainty. Brite, which was launched in mid-1986 with a budget of 125 million ECUS, was hoping for an extension of funding.

Despite the disagreements of the last two meetings, those involved remain confident. Several solutions are being considered, for example, the elimination of programs considered lower priority and less valuable and a cut in certain packages. "The proposal of two billion ecus for the second phase of Esprit could be cut without too greatly compromising its progress and efficiency" it is felt. However, agreement is unanimous that the compromise must not be deferred too long. Any delay beyond the end of the year would be taking an historical risk of throwing a damper on the incredibly dynamic surge in data-processing technology generated by Esprit. This would be a shame with respect to the creation of a competitive European industry in that sector.

For a trial program, Esprit was a master stroke. It is certainly the first time in Europe that anyone has succeeded in synchronizing the work of several thousand people of different cultures. Until now, community research and development programs have been limited to a maximum of 100 to 200 people. The formula used--arranging for the collaboration of competing companies from at least two different countries on a precompetitive research program--is a new one in Europe. True, it is inspired by what the Japanese Ministry of Industry (MITI) has been doing successfully for the last 15 years: bringing together around a single table, in the form of a "steering committee," the large competing companies in order to jointly define a technological strategy and the broad outlines of the research needed to support it. Research is conducted jointly with MITI's financial backing and on completion of the research, each participant returns to his company with the results, at which time competition to develop and commercialize the produce begins.

Etienne Davignon, then vice-president of the EEC, initiated the formula in 1982 by gathering together the 12 great European industrial companies (Footnote 1) (Three German: AEG, Nixdorf, Siemens. Three English: GFC, ICL, Plessey. Three French: CGE, Bull, Thomson. Two Italians: STET and Olivetti, and one Dutch, Philips). To everyone's surprize and satisfaction, this formula works just as well for the Old World, attached to its cultures, principles and rivalries. After a trial phase and two years of experience, all the participants are unanimous: "We've learned to know our competitors, work together and appreciate each other. Better still," comments Pierre Lepetit, "a spirit of self-discipline has grown up within these cosmopolitan research teams, which quickly exposes and forces out any imposters." There is real competition among the teams. Each participant is an associate he brings his know-how, money, and at the end of the contract, benefits equally from the results of the joint research. If a patent is filed, each associate is a co-owner. But a freeze of results is strictly out of the question. The commission sees to it they circulate: they are exchanged among different partners in other programs or surrendered for compensation. The ultimate purpose is for these results to lead to product development, preferably by European firms. Any surrender of a license to a non-European company must be approved by all the collaborators. European research has more than one virtue. "Collaboration of engineers from different cultures is much more productive than collaboration within a homogenous team," comments Emmanuel Tricaud, assistant to the general director of Syseca. The financial and human resources of four, five or more companies (some collaborations combine over 15) makes it possible to explore very different avenues than those a company, even a large one, could have done alone. And the money thrown in to sweeten the pot by the Commission (50 percent of the research costs) encourages costly, long-term and risky research that French companies tended to neglect. "If it were not for Esprit, we would have abandoned certain areas," acknowledges Pierre Lepetit.

In fact, all the programs are a huge success. The response to bid sollicitations proves it. There were more than 600 submitted for Esprit's first open bidding; 560 for Brite; and for Comett, which has not yet gotten off the ground, there are 600 proposals already on the Commission's desk. "Most of them came from the British," says Jean Paul Desbrueres, special project head with the Ministry of Social Affairs and Employment. The large companies, especially the 12, always capture a large share of the contracts. Thomson is involved in 50 and more than 200 researchers work on them full-time, which represents operating costs of 150 to 200 million francs out of a total R&D budget of 6 billion francs! One-hundred forty Bull engineers are working on 30 contracts, with a budget of 15 million ECUS financed by the EEC (50 percent of the real cost of the research), or the equivalent of 4 percent of the group's total R&D budget.

Although the large companies still conduct 50 percent of the research, small and medium industries, which naturally have research potential, are now taking a more and more active part in the programs. They do 35 to 40 percent of the work involved in Esprit. Bertin, for example, participates in two projects. One, "Sacody," studies high performance robots with real time dynamic compensation the other, "Accord," deals with the development of an integrated

software environment for electronic equipment CAO. A third project is being negotiated. "We are also participating in two Brite program projects. There is no problem," comments Richard Grossin, Bertin's head of Community programs, "the formalities and files are relatively simple compared to those required by Anvar to finance national research or Eureka projects."

The participation of French companies is very good. They are involved in 8 out of 10 projects. A total of 60 companies and 200 research teams are working on the Esprit project. When they are involved, these teams carry out nearly 30 percent of the work and thus receive 30 percent of the contract financed by the EEC. A share greater than the funds invested: France's share in the EEC budget is 19 percent. Brite is also a huge success: 57 French companies are involved, including around 10 small and medium industries and as many laboratories and research centers.

Not everything, however, is a success. Five to eight projects out of every hundred are discontinued. Three or four at Thomson and two or three at Bull. This is nothing unusual, these rejects are necessary to insure quality results--their number is not even considered adequate. In fact, despite regular audits by experts (programs are reviewed every 6 months), it is apparently more difficult to terminate an unsatisfactory contract than to let it run its course.

Aside from these failures or partial failures, which are a necessary evil, the scorecard after two and a half years is promising.

In the field of micro-electronics for example, results, though still incomplete, show promise of a future family of gallium arsenide components, intended for use in the design of the supercomputer generation, among other applications. In software engineering, the PCTE (Portable Common Tools Environment) project has the potential to generate a future world standard in software engineering. It will eventually be adopted by all the European firms and certain teams in the American Defense department are already interested. The first objective of this far-reaching program, on which two English companies, GEC and ICL, a Germany company, Nixdorf, the Italian company Olivetti and the French company Bull, are collaborating, is to define a structure to house the software engineering environment created by Unix. In addition to core program, there are 40 projects for the development of tools adapted to this structure; some of them are functional. For several months, PCTE has been exploiting the results of a French research project of the same kind baptized "Emeraude", conducted by three national companies: Syseca, Eurosoft and Bull. Research has led to the development of tools installed in Bull's SPS7 work stations. The terms of the collaboration agreement between the European project PCTE and GIE Emeraude authorizes the use of Emeraude free-of-charge for any Esprit program project participant for the duration of the research. Moreover, the GIE is negotiating other agreements with the British research program Alvey.

A beautiful example of reciprocal cooperation: Emeraude aids the PCTE project, but without this European program, its influence would not have spread so quickly in Europe. The CNMA project (Communication Network for Manufacturing Application) is also promising. With a budget of 15 million ECUS, it brings together users and manufacturers (British Aerospace, Aeritalia, BMW, Peugeot,

Bull, Siemens, Olivetti, Nixdorf, GEC and the engineering company TITN) to study a real time communications network in a shop. Initial results will be demonstrated at the Hanover Fair on a British Aerospace Airbus 320-manufactured workshop cubicle. "The first phase of our research resulted in the creation of communications software installed in our different SPS7 materials," explains J.F. Remille, of Bull's strategy and planning division. "Ultimately, we will create a European standard for workshop communication compatible with the MAP (Manufacturing Automation Protocol) protocols already widespread in the United States."

Midway through the Esprit program, the most sensitive repercussions are those associated with the establishment of European standards. Another example: the PODA project, which again unites the big companies--Siemens, Bull, Olivetti--must also define a documents hierarchy for all automated office systems.

The same is true for "RACE", since its goal is the definition of a wide-band European network, in other words, a European standard. The Postal, Telephone and Telegraph administrations will define and select the systems and the industrial companies the technologies and terminals. The whole system must be totally compatible.

These efforts at standardization, essential for the creation of a real European market, are the direct outcome of Esprit, and go far beyond Community research programs. The 12 industrial companies which met in Brussels decided, at the same time Esprit was set up, to promote a European standardization policy for everything relating to information technologies. They committed themselves to applying these standards in developing their own products and the governments agreed to implement a public buying policy adhering to them. These decisions, adopted in the Council of Ministers, spawned two specific organizations: SOGITS, a group of upper-level bureaucrats responsible for defining functional standardization policies and a smaller unit christened SPAG (Standard Promotion and Application Group) which unites the European subsidiaries of international standardization organizations such as CEN, CENELEC, CEPT ...

"This organizational model has captivated the Americans and the Japanese, who have created similiar entities, dubbed COS in the United States and POSI in Japan," explains Emmanuel de Robien, Bull manager. "We have founded an organization which cooperates perfectly in drawing up future world standards." And in this area, Europe maintains a lead. The SPAG group has spun off a service company, "Spag Services", founded by eight of the 12 big European companies, responsible for developing validation tools for the functional standards defined by SPAG. The initial effects have already made themselves felt. "We have achieved virtual compatibility among the various express services," Emmanuel de Robien states, "14 European and American manufacturers have adopted the same standards!"

In addition to establishing standards, Esprit has made possible many agreements outside its bounds that would never have seen the light of day without it. This is the case with Siemens and Philips, who have decided to jointly develop MOS and bipolar components, and with Thomson and SGS, who will jointly manufacture 4 and 16 megabit programmable memories. "The Eprom program would never

have materialized without the relationships formed around the Esprit table," agrees Pierre Lepetit. The same is true for most Eureka projects in micro-electronics and information technology. Most of them are extensions of relationships formed during 2 years of joint work on Esprit.

Another example of the impact of Community research, Comett, which has not yet gotten off the ground, has already stimulated the creation of a consortium dubbed Saturn. Under the impetus of Open, a British university, Saturn unites all the European universities and industrial companies. "Saturn's vocation," explains its vice-president Jean Paul Desbrueres, "is to create a European university of technology." What no one has been able to accomplish in the 30 years of European Community existence, Comett has initiated in one year, centered around a community research program.

All things considered, then, clipping the wings of these research programs that are just getting off the ground might amount to a definitive condemnation of Europe.

Boxed Material

COMETT

University-Business Cooperative for Technological Education

Objective: to develop basic and continuing education in advanced technologies, to train students, executives, engineers, technicians and educators.

Target Date: first call for bids in 1986. Submission of applications/files 31 March, 1987 and 1 July, 1987

Duration: 3 years (87/89).

Budget: 45 million ECUS (EEC share).

Total budget of 90 million ECUS.

Organization: a collaboration of companies or universities from at least two different Community countries.

Relevant Address: Assemblee permanente des chambres de commerce et d'industrie
Direction formation Emploi
Programme Comett
45, av. d'Iena 75116 Paris

9825

CSO: 3698/425

CIPI APPROVES ITALIAN INDUSTRIAL R&D PROJECT FUNDS

[Editorial Report] Rome GAZZETTA UFFICIALE DELLA REPUBBLICA ITALIANA in Italian on 12 May 1987 publishes resolutions adopted by the Interministerial Committee for the Coordination of Industrial Policies [CIPI] concerning the admission of Italian industrial research projects to the Special Fund for Technological Innovation established by Article 14 of Law 46 of 17 February 1982. In CIPI's 13 March session, the following company projects were admitted to the fund:

Elettrocarbonium S.p.A., large company classification

Program: new generation of graphite and amorphous carbon electrodes.

Eligibility (ex article 16, law 46/82) resolution of the Minister for Industry of 27 November 1986.

Place of execution: Narni Scalo (Terni) Ascoli Piceno

Form of financing: easy credit available at an annual interest rate established by article 15, law 46, of 17 February 1982. Subsidy provided under the third sub-paragraph of article 15, law 46, of 17 February 1982.

Maximum amount: a) easy credit: 22.5 percent of the allowed costs of 1,920.453 million lire, 1,344.317 million of which is to be allocated to the North and 576,136 to the South. b) subsidy: to be established by the Ministry of Industry on the date of stipulation of the contract as established by the third sub-paragraph of article 16, law 46/82, on the basis of 22.5 percent of the allowed costs, to be calculated according to the procedure established by article 15 of the aforementioned law and by sub-paragraph a) of the present resolution.

Amorization: 10-year amortization in addition to the 5-year period of utilization and preamortization starting from the date of stipulation of the contract.

Starting date of the program: 1 September 1984

Estimated date of program completion: 1 March 1989

Ing C. Olivetti E C. S.p.A, large company classification

Program of technological innovation for products and processes for new workstations, personal computers, minicomputers, auxiliary units and interconnections in the field of distributed data processing and office automation.

Eligibility (ex article 16, law 46/82): resolution of the Ministry of Industry of 30 May 1986.

Place of execution: Ivrea (Turin)

Form of financing: easy credit available at an annual interest rate

established by article 15, law 46, of 17 February 1982. Subsidy provided under the third sub-paragraph of article 15, law 46, of 17 February 1982.

Maximum amount: a) easy credit: 27.5 percent of the allowed costs of 53,245.5 million lire. b) subsidy to be established by the Ministry of Industry on the date of stipulation of the contract as established by the third sub-paragraph of article 16, law 46/82, on the basis of 27.5 percent of the allowed costs, to be calculated according to the procedure established under article 15 of the aforementioned law.

Amortization: 10-year amortization in addition to the 5-year period of utilization and preamortization starting from the date of stipulation of the contract.

Starting date of the program: 1 January 1985

Estimated date of program completion: 31 March 1987.

S.G.S. Microelettronica S.p.A., large company classification.

Product and process innovation for very high integration semiconductors in digital and analog-digital technologies.

Eligibility (ex article 16, law 46/82): resolution of the Minister of Industry of 27 November 1986.

Place of execution: Agrate Brianza (Milan)

Form of financing: easy credit available at an annual interest rate established by article 15, law 46, of 17 February 1982. Subsidy provided under the third sub-paragraph of article 15, law 46, of 17 February 1982.

Maximum amount: a) easy credit: 27.5 percent of the allowed costs of 19,462.257 million lire. b) subsidy: to be established by the Ministry of Industry on the date of stipulation of the contract as established by the third sub-paragraph of article 16, law 46/82, on the basis of 27.5 percent of the allowed costs to be calculated according to the procedure established under article 15 of the aforementioned law.

Amortization: 10-year amortization in addition to the 5-year period of utilization and preamortization starting from the date of stipulation of the contract.

Starting date of the program: 1 January 1985

Estimated date of program completion: 31 December 1988.

Sisas Societa' Italiana Serie Acetica Sintetica S.p.A., large company classification

Definition of new processes for the production of polyreactive compounds with two or more carboxylic and/or oxydrilic groups as organic intermediates for technopolymers and fine chemical products.

Eligibility (ex article 16, law 46/82): resolution of the Minister of Industry of 27 November 1986.

Place of execution: Milan

Form of financing: easy credit at an annual interest rate established by article 15, law 46, of 17 February 1982.

Maximum amount: easy credit: 45 percent of the allowed costs of 4,381.492 million lire.

Amortization: 10-year amortization in addition to the 5-year period of utilization and preamortization starting from the date of stipulation of the contract.

Starting date of the program: 15 April 1986

Estimated date of program completion: 15 April 1989.

Soliveri S.p.A., small company classification

Definition and application of the "ionic discharge" technique for steel nitriding and carbonitriding, with development and extension of this technique for superficial hardening of titanium alloys and of other materials which cannot be processed using traditional techniques.

Eligibility (ex article 16, law 46/82): resolution of the Minister of Industry of 31 October 1986.

Place of execution: Caravaggio (Bergamo)

Form of financing: easy credit at an annual interest rate established by article 15, law 46, of 17 February 1982. Subsidy provided under the third sub-paragraph of article 15, law 46, of 17 February 1982. Maximum amount: a) easy credit: 27.5 percent of the allowed costs of 823.315 million lire. b) subsidy to be established by the Ministry of Industry on the date of stipulation of the contract as established by the third sub-paragraph of article 16, law 46/82, on the basis of 27.5 percent of the allowed costs to be calculated according to the procedure established under article 15 of the aforementioned law.

Amortization: 10-year amortization in addition to the 5-year period of utilization and preamortization starting from the date of stipulation of the contract.

Starting date of the program: 1 June 1985

Estimated date of program completion: 31 December 1988.

8606

CSO: 3698/M280

EC COMMISSION PROPOSES FUNDING FOR BUSINESS-INNOVATION CENTERS

Bonn TECHNOLOGIE NACHRICHTEN-MANAGEMENT INFORMATIONEN in German No 451,
16 Mar 87 pp 11-12

[Text] A proposal for a community program for the creation of business and innovation centers [BIC] and for the formation of a network organization was presented by the EC Commission to the council. The commission intends to participate in the following measures with a total of 17,5 million ECU to cover up to 50 percent of costs over a 4-year period (1987-1990):

Preliminary Work for the Establishment and Start of Business and Innovation Centers

The preliminary work includes:

- Organization and initial testing of functions/services of a BIC, particularly concerning the search for, selection, and training of future potential entrepreneurs and small and medium-size companies open to modernization and diversification; the drawing up of company plans; technical opinions; local and international technology searches; advisory services in matters concerning management, legal, commercial, and financial questions and joint property;
- Hiring of advisers experienced in the establishment of BICs;
- Development of plan of action for BICs;
- Establishment and running of the practical work in BICs.

Encouragement of BICs in Specified Areas

Activities may include the organization of seminars in areas which are of particular interest as far as the Community Regional Policy is concerned, and where BICs are to be encouraged.

Inclusion of BICs in the European Business and Innovation Centers Network (EBN)

The Community may continue to subsidize the EBN in 1988 or 1989 if at that time financial independence (as it is presently foreseeable) has not been achieved.

Financial support is given in the form of subsidies toward operating expenses on the basis of a contract with the commission and after receipt of a comprehensive annual report on previous activities and progress.

Development of Methods, Models, and Procedures for Efficient Work in BICs

This includes designing and testing of methods, models, and procedures in connection with successful work achieved by BICs, especially labor planning methods, procedures for the search for and assessment of technologies, and the opening of international markets to small and medium-sized companies and BICs.

8701/9835
CSO: 3698/M221

GDR CONTRIBUTION TO INTERKOSMOS PROGRAM

East Berlin ASTRONOMIE UND RAUMFAHRT in German No 1, 1987 pp 12-14

[Text] The present status and the developmental tendencies of remote sensing were the topic of the 4th GDR conference, which took place in Neubrandenburg from June 16-19, 1986.

One hundred thirty experts from 35 scientific institutions in the GDR, the USSR, CSSR, PR Poland, Hungary, Austria and the FRG discussed problems and possible applications of remote sensing using aerospace devices.

In more than 65 lectures, experiences of basic research and technological development were discussed regarding the utilization of remote sensing in geographical exploration, environmental surveillance, agricultural analysis, cartography, as well as for the first time in the exploration of planets and of Halley's Comet.

The Society for Space Research and Astronautics of the GDR and the work group for natural scientific foundations of earth observations (AGNGF) at the Academy of Sciences (AdW) of the GDR co-sponsored the conference.

In the talks given by foreign participants, specific application fields in the respective countries were described. For example, Dr. Kalman Toth of the Institute for Geodesy and Cartography of Budapest reported on the surveying, classification and mapping of the marshlands zone along the shores of Lake Balaton. As a result, a cartographic series of the Balaton shoreline was produced on a scale of 1:10,000. This series depicts the borders of the marshlands and provides information concerning the quality and harvest prospects of the zone of reeds.

Cartographic and photogrammetric problems, hardware developments, advances in data preparation as well as a poster discussion rounded out the four-day meeting. Questions concerning remote observations and geoinformation are to form the focus of interest at the next conference, which is to take place in two years.

Our colleague Uwe Schmaling spoke with Dr. Karl-Heinz Marek, director of the Methodological-Diagnostic Center for Remote Sensing at the Central Institute for Geophysics of the AdW of the GDR, concerning the developmental status and utilization of remote sensing in the GDR.

AuR: Ten years ago, in September 1976, a large device manufactured in the GDR, the MKF-6 multispectral scanner, was used for earth observations from space. What was the background of this space implementation and what is its significance from our point of view today?

M: The use of the MKF-6, which was initiated in 1976 with the RADUGA Cosmos experiment and which has since then been routinely used on all Soviet space stations, is, like its aircraft variant the MSK-4, a genuine product of the close cooperation that exists between socialist countries in the joint Interkosmos program for the peaceful exploration and utilization of space.

With these undertakings, which are supported above all by the scientists and engineers of the USSR and our republic, the process of multispectral photography has been developed to a level that remains unsurpassed elsewhere in the world, so that, used from aircraft as well as from space, it is today introduced and utilized in a number of countries as a standard procedure for explorations for natural resources and for environmental surveillance. In our republic as well, the initial implementation of the MKF-6 ten years ago represented a first step in the development of a new, space-based technology for the acquisition of data which can help to solve many tasks in such economically and scientifically critical areas as geology and mining, cartography, environmental protection, the development of landscapes and territories, land, forest and water management, oceanography, etc.

AuR: Has it also been possible to put the images obtained in these areas to immediate use to the fullest extent?

M: The reading or interpretation of such pictures and the full utilization of the information they contain usually involve quite complicated processes, for in analogy to the saying, it is particularly true here that one "cannot see the forest for the trees." Despite the often aesthetic and moving images that they present, we unfortunately cannot regard the multispectral color photo as we do a picture or a book--for us these photos represent two-dimensional storage units of information concerning very complicated phenomena and conditions on the surface of Earth. This is particularly evident in other, non-photographic remote observation procedures, the results of which are recorded on magnetic tape.

Basically speaking, the basic technologies required for processing multispectral remote sensing data with the help of visual and optical methods were developed in our research establishments during the second half of the 1970's. At the same time, further prerequisites for a practical utilization of this new type of data in combination with data compiled by conventional methods were created in the potential user areas through the development of a suitable work force and laboratories.

AuR: How did further development in this area take place in our republic?

M: The further technical and methodological development of remote sensing technology had considerable impact on many areas of our society during the last Five Year Plan Period. We might mention just a few examples: at Interflug, a special production facility was established for remote sensing, which today provides every user area of our republic with remote sensing data on a

contractual basis by means of its special aircraft--including MKF-6 and MKF-4 images.

The Robotron and VEB Carl Zeiss Jena combines have manufactured special hardware systems for the processing of remote sensing data, which have also become economically important as export items for the GDR.

In order to train specialists in the user areas, for several years now problems of remote sensing have been taught in approximately 15 different departments at our universities and technical schools.

The focus of methodological research activities has dealt with the field of computer-assisted automated data analysis. The first joint USSR/GDR space flight to the Salut 6 station also took place at this time, an endeavor which provided us, among other things, with an opportunity to test and introduce an additional remote sensing procedure, the so-called visual-instrumental earth observation, and thereby also contributed to the overall development of remote sensing. In recent years, the exploration of the world's oceans has been moved ahead as the result of the implementation of spectrometric measuring devices on Salut 7.

Finally, and this is decisive, in the final analysis, in all of the above-mentioned sectors of the national economy and scientific fields, we have had the opportunity to acquire our own practical experience with space-based remote sensing, which made it possible for us to carry out a realistic evaluation based on the natural sciences and to compare these results with conventional methods of data acquisition. Nonetheless, it should be clearly emphasized that, in overall terms, this technology is still in an experimental phase all over the world.

AuR: The economic effectiveness of this technology makes sense in principle. Can you cite other examples of possible applications and their value to our national economy?

M: Multispectral images and other products of remote sensing have been tested in the GDR in over 20 user areas as up-to-date and precise initial data for various types of mapping, which, as we know, represent urgently needed bases for surveillance, control, planning and decision-making in many areas of our society. From the large number of experimental applications of space and aircraft photographs, I would like to mention

- the initial processing and geological evaluation of observation areas in order to implement the cost-intensive exploration technologies (drilling, seismic studies etc.) in a targeted and economically efficient way;
- mining surveying for the supervision of brown coal strip mining operations;
- site evaluation for soil improvement and crop production;
- forest inventories, monitoring forest conditions, updating of forestry maps;
- indirect environmental control of forest massifs, surface waters and the impact of mining on the landscape;

- the updating of topographic maps;
- creation of land use maps to carry out assessment planning, to draw up general construction and regional development plans and for site planning, to mention just a few applications. In all areas, remote sensing represents a rationalization means for obtaining very varied and urgently needed information. However, generally speaking, the value of such information cannot be easily defined in monetary terms,...

AuR: ...Just as we are not able, for example, to set an economic value for up-to-date weather information. The economic evaluation of information is certainly a problem that remains unsolved in international terms as well.

M: Aside from this, a trend can be observed today in Western countries in the direction of the extreme commercialization of space-based remote sensing. For a copy of a single photo covering approximately the same territory as does an MKF-6 photo, several hundred U.S. dollars are demanded, not including the high costs for evaluation and cartographic conversion.

AuR: We obtain remote sensing data from aircraft from the previously-mentioned enterprise for remote sensing and industrial and research aeronautics at Interflug. How do we have access to space data?

M: Because of our participation in joint scientific experiments under the aegis of the Interkosmos program, our user areas were able to utilize free of cost the images obtained by Soviet space craft. For many years now, these photographs have completely covered our national territory. However, up-to-date photos are needed for many purposes. They are prepared by manned and unmanned Soviet space craft and are available to our user areas on the basis of special governmental agreements. The powerful Cosmos potential of the USSR can therefore be tapped in a way that also benefits our own scientific research and our national economy.

AuR: The realization of the Interkosmos program demonstrates how space research today can serve the well-being of all peoples, through close international collaboration. The military utilization of the insights and possibilities of space research by the U.S.A., however, carries new dangers for humanity and for the survival of the human race. How do you view this striving for the militarization of space and the possibilities of a military application of remote sensing technology?

M: Like few other areas, remote sensing offers avenues for overcoming fundamental human problems, such as securing food, prevention of disasters, resource exploration, etc.

For this to happen, only one prerequisite need be met: the preservation of status of space as a territory that belongs to all of the peoples and which is to be kept free of any kind of weapon--as the socialist countries have repeatedly proposed. In the U.S.A., however, a process is underway at the present time that clearly demonstrates to us that science and technology can also be used to the detriment of society, to assert a striving for dominance. In that country, space is being increasingly regarded as the major theater for future military confrontations, through which--for the first time in human history!--the very existence of the human race is threatened. It is of course

significant that despite the undisputed pioneer role of the USSR in space flight and space exploration, satellites for military purposes were always first implemented by the U.S.A. Even on board the space shuttle, several components of the insane SDI concept were tested. In this strategy, the misuse of remote sensing by military reconnaissance satellites for spying, early warning and missile guidance plays a special role. The military utilization of space by the U.S.A. and the military misuse of remote sensing are, by their very nature, totally inhuman and hostile to science; they represent a waste of enormous material value and intellectual potential. Because we certainly wish to continue to use remote sensing in view of the problems that face us with regard to resources and the environment, all the while still hoping to preserve the peace, I see in the realistic disarmament proposals put forward by the USSR a genuine hope for a space without weapons and an earth save from nuclear destruction. On the other hand, it should also be remembered that remote sensing within the framework of internationally agreed-upon mutual disarmament tasks can also make an important contribution to international security and the build-up of trust, and thereby to ensuring the peace. Here, too, it is a question of the objectives that govern the use of remote sensing technology.

AuR: Our thanks for this interview.

12792

CSO: 2302/25

DEVELOPMENT, PROSPECTS OF ROMANIAN AIRCRAFT INDUSTRY

Bucharest REVISTA ECONOMICA in Romanian No 52, 26 Dec 86 pp 8-10

[Article by Ion Petroaica, general director, National Center of the Romanian Aeronautical Industry: "The Process of Restructuring the Economy in Accordance with Future Requirements: Past, Present, and Future in the Aeronautical Industry"]

[Text] Romania is one of the chief promoters and developers of powered aircraft. The Romanian school of aeronautics has been and is recognized throughout the world as one which has made and continues to make a substantial contribution to development of the aircraft industry and one which has world-renowned scientists and designers. In addition, Romania has always been one of the countries achieving some of the most representative results both in research and in aircraft design. The names and accomplishments of bold pioneers of Romanian and world aviation, Traian Vuia, Aurel Vlaicu, and Henri Ceanda, and of the following generations of talented Romanian aircraft designers, are known and renowned throughout the world. Tens of thousands of others have contributed their talents and efforts along with these pioneers in the complex and difficult work of aircraft design involved in creating and developing the Romanian aeronautical industry.

The first types of flying machines were mass produced in 1911, and talented aircraft designers subsequently worked in the shops and departments of the IAR (Romanian Aeronautical Industry), SET (Technical Operations Company), and ICAR (Romanian Aeronautical Design Enterprise) plants, where dozens of types of aircraft were built both under license and on the basis of original designs. The performance and originality of these planes placed them among the leading developments of the period before the Second World War.

After the war, specialized aeronautical production facilities existed in Romania at Bucharest and Brasov. Starting in 1968, new impetus was given to modernization and development of production and research facilities in the area of aeronautics. The exclusive credit for this is due the secretary general of the party, Comrade Nicolae Ceausescu, who, when he was first elected to his position, both understood the need for creating a new and powerful aviation industry and made a realistic evaluation of the technical and scientific potential available to the country, thereby becoming the founder of modern Romanian aviation.

Romania's position as one of the leading world producers of aircraft seems natural when we consider the priority in technology accorded the Romanian school of aeronautics from the time of the first powered flight in the world. From the take-off of the first Traian Vuia plane in 1906 to the time of the flight of the first jet transport aircraft, the Rombac 1-11, Romanian industry has produced dozens of types of airplanes, including 70 of original design, to which are to be added 30 types of gliders and power gliders of original design. There is nothing more natural than that the country which gave the world Henri Coanda, the designer of the first jet aircraft in the world (1910), the designer of the first helicopter in the world, George de Bothezat, or the creator of gliders and power gliders Iosif Silimon should today produce powered aircraft, helicopters, or gliders of different types and complexity. The Romanian aeronautical industry currently produces 20 types of aircraft, which include transport aircraft, performance aircraft, light and medium helicopters, industrial and training airplanes for air clubs, gliders and power gliders, aircraft engines, and airborne equipment.

While in 1968 the total number of workers in the aeronautical industry was 2,484, with fixed assets of only a few hundred million lei, in the 18 years of operation, material effort, and application of know-how extending from 1968 to the present new aviation enterprises have been built, outfitted at a high technical level, and activated and old facilities have been developed and radically transformed. The value of fixed assets has increased by a factor of 16 over this period, commodity output and gross output have grown more than 20-fold, and the total number of workers has multiplied by 10.

As production facilities have developed, priority programs have been initiated for manufacture of light airplanes, small and medium-sized helicopters, turbojet and turbine engines, mechanical assemblies, industrial aircraft, and gliders and power gliders based on an original design or under license. The beginning was marked by manufacture in 1969, at what is now the Bucharest Aircraft Enterprise and exclusively for export, of the BN 2 Islander light passenger transport airplane (10 seats), on the basis of documentation provided by the British firm of Britten Norman. More than 380 such airplanes have been built thus far. The technological experience gained through this program enabled start-up in 1974 of manufacture of subassemblies of the BAC 1-11 airplane for the renowned British aeronautical firm British Aerospace.

In the area of agricultural aircraft activities have focussed on manufacture of small series of airplanes on the basis of original documentation, such as the IAR 827 airplane designed by the Aviation Institute and produced by the Bucharest Aircraft Enterprise. This plane has a chemical substance payload of 800 to 1,000 kilograms. Its development has resulted in the IAR 828 agricultural airplane with improved performance and higher payload.

Light aircraft are also well represented. There is the IAR 823 light airplane equipped with a conventional engine made at the Brasov Aeronautical Construction Enterprise, which is also famous for gliders and power gliders based on original designs. One of the types of power gliders, in a formation of three, accomplished the feat of completing a flight in stages from Romania to Australia, covering 22,000 kilometers with no technical problems.

On the basis of a long-term cooperation arrangement, the Bucharest Aviation Enterprise has manufactured the IAK 51 light training and acrobatic plane;

1,000 have been produced up to the present, most of them earmarked for export. As a result of extending cooperation with the Soviet aeronautical industry, the production of piston engines for this airplane has begun, as well as manufacture of engines and reduction gears to be used in the Ka 126 helicopter.

The scope of activity of the Romanian aeronautical industry has been considerably broadened. Specialized enterprises now manufacture precision cast and forged intermediate products of special non-ferrous alloys and high-alloy steels specific to aeronautical construction, as well as components of electric, radio, and radio navigation systems, airborne equipment, and hydraulic, fuel, pneumatic, and air conditioning components needed for production aircraft and engines.

Another important accomplishment of the Romanian aeronautical industry has been manufacture of the IAR 316 light helicopter and the IAR 330 medium helicopter under license, both for domestic needs and for export. (Further development of these helicopter types is being considered.) The Turbo IV C turbine engines and mechanical assemblies (high-precision products of particular technical complexity) with which the IAR 330 helicopters are equipped are also made in Romania, at the Turbomecanica Enterprise. In the area of helicopter manufacture, effort is continuing to increase the degree of integration of the systems manufactured, including that for the purpose of developing rotors with blades of non-conventional structures reinforced with carbon fibers and creation of the conditions necessary for starting up production of Romanian-designed helicopters.

Another impressive accomplishment of the Romanian aeronautical industry has been the manufacture in Romania, under license, of the Rombac 1-11 passenger jet airplane with a capacity of 120 passengers and a maximum range of more than 2,500 kilometers.

While during the first years after 1968 aircraft production, both under license and on the basis of original designs, was accomplished with imported materials and equipment, emphasis is now placed on increasing the degree of integration of aircraft by manufacturing materials and equipment in Romania. The recognized competitiveness of Romanian aeronautical products, proved both by the export demand and the interest displayed in Romanian products participating in expositions and demonstrations, is based primarily on their faultless quality, an indispensable requirement in the aeronautical industry. This quality has been achieved through implementation of a complete quality assurance system and the high skill of aircraft specialists. The good qualities of Romanian-made aircraft have acted as recommendations, with the result that many customers have requested these aircraft. Up to the present, more than 1,500 have been sold in 10 countries, some with traditions of their own in the area of aeronautics. Constant additions are made to these figures on the basis of new contracts.

The diversification of aeronautical production and the faster pace in integration of products being manufactured have led to the need for increasing the number of modern technologies, either new or redesigned. By implementing the measures contained in the special plans drawn up, aircraft design units have in a relatively short time become beneficiaries of leading-edge technologies such as controlled bending of soft milled skin panels, doubling

of skin thickness, wide use of numerically controlled machine tools, production of non-conventional aeronautical structures of metal honeycomb design or of glass or carbon fiber, use of spark erosion machining and chemical milling, etc.

Development of the Romanian aeronautical industry has proceeded by two methods up to the present. The first is extensive, involving development of new production facilities, and the second intensive, involving use of the latest technologies. In the future the emphasis will be placed on the intensive aspect, that is, use of existing facilities with greater efficiency. To this end, priority is assigned to development of new technologies of original design, both in units under the National Center of the Romanian Aeronautical Industry and in horizontal industry, to enable broadening of the range of material and equipment made in Romania for aircraft and engines currently in production or on the designers' drawing boards. By using the experience gained in designing from scratch or in starting up production of numerous items of equipment, materials, and technologies with high parameters required by the standards and norms of the aeronautical industry, the pertinent institute and the production departments specializing in production start-up in each unit of the CNIAR (National Center of the Romanian Aeronautical Industry) are today capable of diversifying products so as to meet any of the needs of national industry and export requirements.

The current development of the Romanian aeronautical industry and the future prospects of these activities represent impressive accomplishments of Romanian industry, the fruit of the wise policy of our party and state, representing the most eloquent possible expression of the creative genius of the Romanian people. Benefitting from the constant support and guidance of the secretary general of the Romanian Communist Party, Comrade Nicolae Ceausescu, who is frequently to be found among the workers of aviation industry enterprises and who is constantly concerned with improving and developing these enterprises on the basis of bold new aeronautical programs, the aviation industry has had the conditions created for it which are necessary for turning out aeronautical products of increasing complexity and superior performance at the world technological level. The plan is to diversify the range of aircraft and engines, develop new equipment, reduce specific consumption, and increase the degree of economic efficiency of aeronautical products so as to make these products increasingly competitive on the international market.

[Box, p 8]

The IAR-823 Light Airplane

The IAR-823 airplane made by the Ghimbav Aeronautical Construction Enterprise is a single-engine low-wing plane equipped with a Lycoming -- IO 540 GID 5 290-horsepower engine and Hartzel twin-blade propeller. It has tricycle landing gear with steerable forward wheel. The airborne equipment ranges from the simple instrument panel absolutely necessary for daytime flying (standard version) to the most complex one required for nighttime flight.

The aircraft, which is used especially as a training and instructional plane, was designed and produced so as to permit its use in performing a varied range of missions: liaison, courier, commandant, air taxi (in a version with 4 seats, space for baggage, complete airborne equipment); acrobatic flight

missions, nighttime flying or flight under difficult weather conditions (in a version with 2 seats and dual controls); cargo and medical missions, photogrammetry, aerial observation or surveillance (in a version with 2 seats and rear seats dismounted).

[Box p 8]

The IS-28 B2 Glider

Designed on the basis of the most advanced performance and quality standards, the IS 28 B2 glider combines a number of characteristics of training and instructional gliders with the superior performance of competition and acrobatic gliders. It is of all-metal construction, of light alloys, with a "high" wing and type T horizontal tail unit made up of stabilizer and elevator. The forward fuselage is of the semicoque type, the mid-fuselage of the truncated cone type, and rear fuselage of the semicoque type. The wing is outfitted with a camber flap which can assume 6 positions in flight and with a "Hutter" aerodynamic brake. To facilitate transportation, the horizontal tail unit can be folded in the direction of drift.

The cockpit has two pilot positions in tandem covered by a single transparent dome; the two pilot positions have all flight controls available. Technical data: length 8.42 meters, height 1.87 meter, wingspan 17 meters, maximum takeoff weight 590 kilograms, maximum speed 230 kilometers per hour.

[Box p 9]

Ratings of Romanian Aircraft

In April 1979, American pilots Tom Knauff and Robert Tawsse IV of Pennsylvania set a world record with the IS-28 B2 glider, covering a distance of 829 kilometers. From May to July 1980, 3 Australian pilots flying 3 IS 28 M2 power gliders navigated from the runway of the Brasov enterprise to Tocumwal in Australia, covering a distance of 22,000 kilometers in 154 hours of flight and setting another world distance record. On taking off from Brasov for Manila in the Philippines aboard a IS 28 M2 glider, the Spanish pilot, Arturo Rodriguez, said "I want to fly it to prove its exceptional qualities. It is currently the sturdiest and most dependable power glider in its class in the world."

The IAR light and medium helicopters are especially well regarded around the world. The Islander BN2 airplane has enjoyed remarkable success. All these airplanes and helicopters have been and continue to be exported by the tens and hundreds.

[Box p 9]

The IAR-330 PUMA Helicopter

Built under French license by the Chimav Aeronautical Construction Enterprise, the IAR-330 PUMA medium utility helicopter can carry 2 pilots and 21 passengers; it can be modified into different configurations for various uses. The reserve power of the 2 TURBO IV C engines ensures excellent performance under any climatic and flight altitude conditions. Cargo and

passengers can be transported efficiently at a cruising speed of 272 kilometers per hour (the plane can be equipped with a flotation device to ensure safe flight over water).

With a volume of 11.4 cubic meters and a useful area of 7.80 square meters, a carrying capacity of 800 kilograms per cubic meter, and 13 anchor points, the helicopter can be adapted for a variety of transport missions. Certified IFR (class AB) by the DGAC and FAA, the helicopter is outfitted with all the equipment necessary for performing missions under difficult flying conditions.

The structure of the IAR-30 PUMA helicopter permits ease of maintenance and is very rugged. The helicopter can carry the necessary airfield equipment, so that maintenance and any necessary replacement of parts can be accomplished without resorting to other ground installations. When in the open position, the turbine cowlings can be used as work platforms. Routine tests can be performed on the ground; the number of lubrication points has been reduced, and the large-scale use of self-lubricating bearings further simplifies maintenance. Many components are duplicated, including the engines, so that interchangeability is ensured. This results in a high degree of availability and minimum investment in spare parts. The use of composite materials for the main blades, which are interchangeable and have a virtually unlimited service life, contribute to reduction of maintenance costs.

6115

CSO: 2702/7

HUNGARY: TRENDS, ACHIEVEMENTS IN BIOTECHNOLOGY NOTED

Budapest HETI VILAGGAZDASAG in Hungarian No 7, 14 Feb 87 pp 52-53

[Article by Istvan Palugyai: "The Clones of Modern Times"]

[Text] Biotechnology is often compared with electronics; it too is one of the fastest developing industries of our times and provides enormous financial possibilities for the countries which woke up in time and, from the beginning, have asked for their share of bioindustrial activity. Our report provides a bit of insight into the domestic situation of the new industry.

"The train departing was already given the green light but we were still merely standing in line at the ticket counter"--is how skeptic domestic scientists characterized the situation of Hungarian biotechnology compared with the international forefront. It is true that there is a glimpse of hope in this opinion because the train has not yet left. Namely, even in the West, biotechnology is not quite where electronics is, for instance, it has not been so organically incorporated into production. Nevertheless, advances are explosive here also and, according to some experts, the modern bioindustry can earn as much as 200 billion dollars in global production value by the turn of the millennium compared to the current 12 to 15 billion dollars.

In fact, biotechnology has always existed ever since man has been engaged in agriculture because, in the course of leavening, fermentation and siloing, man has utilized the life processes of microorganisms, mostly of yeasts. However, the modern, "new" biotechnology, referred to with increasing frequency these days, is already using an increasing arsenal of the modern sciences such as genetics, microbiology, biochemistry and biotechnology in order to put to work these tiny living creatures or some of their intentionally altered parts, the genes.

In Hungary, the more important biotechnological, biochemical and biotechnical methods, accompanied by other methods, are all found in the program of the OKKFT [National Central Medium Term Developmental Plan] of the seventh Five-Year-Plan period entitled: "Initiation, development and application of biotechnological procedures in agriculture and industry." According to the plans, 8 to 10 universities, 18 to 20 enterprises and factories and 5 to 8 other institutions will participate. At the present time, biotechnological research and development is being conducted in 50 domestic institutions.

The number of professionals working in this field today is merely 450 to 500 individuals. This is just one and a half percent of the number of workers engaged in R + D (research and development) in the country, moreover, they are very poorly distributed. Namely, at present we have only 8 domestic research places where the number of people engaged in biotechnology exceeds 10. Among the biotechnologists, those doing basic biotechnological research or collaborating in the long-range development do not participate in the realization of the central program. According to the most optimistic calculations, at present another 30 to 40 professionals would be needed to accomplish the program although it really is not yet known how many of the 450 to 500 professionals will participate in the program.

According to the plans, a total of about 1.94 to 1.98 billion forint is needed to cover the finances of the 5-year program of which nearly 1 billion should be covered from the central technical development fund, 220 million from budget support and 770 million forints from enterprise resources. Balancing is the task of the Protein and Biotechnology Bureau of the OMF B [National Technical Development Committee], the manager of the program. The money derived from central sources was divided on the basis of competition.

For the competitiveness of biotechnology, for continuous and secure work and for making the program achievable in general, foreign exchange is also needed in addition to forints but the current system also contains elements of uncertainty in this respect. Namely, OMF B has an annual foreign exchange appropriation but in vain; if, for various reasons, at least one third of these appropriations is not used up by the end of the year, the foreign exchange sum "gets lost", that is, its appropriation must again be formally requested. It is incomprehensible because, if the OKKFT is of preeminent importance for the development of our economy, moreover, the necessary "central" forints are allocated for five years without restrictions, why then cannot the same thing be done with the foreign currency which is at least as important?

Modern biotechnology demands a new type of thinking not only from the scientists but also from the economic professionals, managers and financiers. In this field, industrial development from the research results can only be expected after 4 to 7 years even in the leading biotechnological companies of countries having the most developed technology and, in a given case, practical profit after an additional number of years. It is true that the investments will probably be amply returned then.

It is an international experience that, in biotechnology, mostly small and medium sized enterprises become successful. This is the reason that managers of the domestic programs are also urging the establishment of developmental units next to the research laboratories and of competitive small enterprises. In our country, however, it appears that the "starting money" is lacking for the equipment of experimental plants larger than of laboratory dimensions.

The distressing absence of technical equipment needed for the effective cultivation of biotechnology is in part a consequence of this lack. Modern biotechnology requires process guided fermentors, microprocessor guidance systems, multichannel analyzer and evaluator installations and special

instruments. In other words, such top technologies which are very difficult to obtain in Hungary. Therefore, often the only possibility is domestic development, the resourceful work of engineers and technicians. Among the few examples is the work carried out in the Department of Agricultural Chemical Technology of the Technical University of Budapest and in the Central Research Institute of Chemistry of the MTA [Hungarian Academy of Sciences] the goal of which is, among others, the development of an experimental plant also suitable for carrying out "bioengineering" tasks.

In the road from research laboratory to industrial production, the first step is the establishment of so-called large laboratories. But a cooperation between biologist and developmental engineer is worth while already at the level of basic research in microbiology. Namely, the latter designs the bioreactor, the complete technical background whereby the given procedure can be done most economically. It is not really a simple task since we are dealing with living matter. Something that gives excellent performance in the laboratory might even be an utter failure on an industrial scale; after all, biological systems "work" with living organisms and not inanimate ones where an increase in scale and number of pieces produced can, in general, be accomplished without difficulty.

Taking this into consideration, the Hungarian Academy of Sciences and the Ministry of Industry decided in favor of the establishment of a joint developmental unit, an industrial biotechnological large laboratory which, as a kind of scientific park built on the research base in Szeged, would be set up next to the Biology Center in Szeged. The investment, started with the endorsement of the governmental committees and central subsidy, would consist of an applied research and development laboratory and an experimental plant where the technologies would be worked out.

The other undertaking--the largest scientific investment during the current Five-Year-Plan--will be the construction of a new, independent research center. (Since the Biology Center in Szeged, completed in the early 1970's, no other such center was established in Hungary.) Current plans call for an investment of more than half a billion forints, the sum including the forint value of about 5 million dollars of a World Bank loan. The Agricultural Biotechnological Research Center (MBK) to be established in Godollo signifies by its name already the field in which it wants to accelerate the use of the new biotechnological methods. According to the expectations, MBK would be the developmental base for those agricultural enterprises which, at present, are not yet able to adopt the modern basic research methods, and it will also have a mandate of providing biotechnological training to the specialists of agricultural farms and enterprises. The research-education base with a starting staff of 160 to 170 people must be completed by the first half of 1989, according to the plans.

One of the best known domestic biotechnological enterprises, Meriklon, is also active in agriculture; in response to its tissue culture results, six large laboratories are being constructed all over the country with OMFB support and a Novotrade loan. In addition to Meriklon, the owner of the industrial biotechnological large laboratory in Szeged, Biotechnika Ltd., has an increasingly better sounding name, and the first biotechnological enterprise

to deal with medically oriented goals has also been formed. As a cooperative effort by a few university departments, it will produce monoclonal antibodies for the diagnosis of certain pathogens, hormones and antibiotics, and also cancerous metastases. Makoklon, which was established for a renewal of the famous onion species by means of biotechnological methods, is a joint venture involving the Research Institute for Vegetable Production, several agricultural cooperatives, a foreign trade enterprise, the Zoldert of the Megye and the Protein Technological Scientific Production Association.

For the development and manufacture of biotechnological instruments, serving to replace imports, an additional 5 to 10 small domestic management units were organized and, for marketing the biological products abroad, the Biotechnical Foreign Trade Innovation Society was formed which plans to function as a commercial house later. Hopefully it will have products to trade.

A Few Biotechnological Trends

In modern biotechnology, the techniques based on tissue culture became perhaps the most widespread in the field practice of plant production, also in Hungary. This method has decreased the time required for the traditional process of plant improvement to one-fifth or one-tenth. Also used in many places is the so-called protoplast fusion method which consists of first producing cells without membranes, and using a special technique for their subsequent fusion. Thereby the cell nuclei of different species and subspecies, including the hereditary material, get into a single cell and become the carriers of completely new properties. Using the method--the development of which was advanced by the pioneering work of Hungarian scientists--completely new plant versions, not found in nature, can be produced.

The fusion of animal cells carrying divergent genetic information is also very promising. Among these, perhaps the culture of the so-called monoclonal antibodies (cultured from cells with identical properties), useful in various types of therapy, have the greatest long range prospects in practical usage. A more refined and involved technology involves the transplantation merely of certain chromosome fragments, certain genes mapped on the chromosomes, into other cells.

The direct use of gene splicing in animal breeding is just a future promise as yet. On the other hand, embryo splitting is an already existing practice: animal embryos, split into two or several parts, are implanted into surrogate mothers whereby several progenies--considered identical twins--can be obtained from a single fertilization. Hundreds of such calves and lambs have already been born, also in Hungary. The farmers can also have high hopes from the manipulation of sex ratios: this involves the separation of sperm cells carrying the male and female sex trait. The method, known in Hungary only as a theoretical possibility, is of enormous importance, for instance, in the raising of broilers where the meat yielding male is desired and in the raising of laying hens where the females are sought after.

2473

CSO: 2502/33

HUNGARY: ALLOCATION OF RESOURCES DISAPPOINTS SOME SECTORS

Budapest COMPUTERWORLD/SZAMITASTECHNIKA in Hungarian No 5, 11 Mar 87 p 1

[Text] The electronification economic development program (EGP) has entered its second year. Laszlo Pal, a group chief in the OMF [National Technical Development Committee] reported on this year's tasks, newly introduced regulator elements and economic organizational measures at a press conference.

We already reported on the introduction of some special regulator elements in our first issue for 1987 under the heading "There Are Changes." (The importers of modern technology used only half of the framework provided in 1986 for duty concessions. The commodity classification guide which follows technical development only with a great delay certainly had a role in this.) The economic organizational measures connected with the EGP include--among others--an organization of domestic PPC supply, having the price level for electronic products approximate the world market prices, working out analytical and evaluation methods for statistical data which permits tracking of the EGP, and development of a credit practice supporting the development of electronification, and in 1987 the guiders of the program will try to come to an agreement with the World Bank regarding the extension of credit pertaining to the developmental package plan for electronification.

Unfortunately fewer central resources than planned have gone thus far to the subprograms for telecommunications development, state administration and education; they will receive only 22-25 percent of the original 5-year prescription for the first two years. Because of this execution of the electronification education program is full of tensions and those responsible are studying the possibility of regrouping resources to this area. The many supplementary regulator elements and loosening measures mean overall about 4 billion forints in contributions, savings and concessions for the enterprises. This is only a "drop in the ocean" despite the fact that its effect could be truly significant for the development of domestic electronification. During the current 5-year plan the production value of the Hungarian electronics industry will be about 300 billion forints and 100-120 billion forints will be spent on electronification at the national economic level.

8984

CSO: 2502/50

HUNGARY: PERCOMP, MAJOR PLAYER IN PPC FIELD

Budapest COMPUTERWORLD/SZAMITASTECHNIKA in Hungarian No 5, 11 Mar 87 pp 1, 32

[Unsigned article: "PerComp Steps on the Scene"]

[Text] A few small cooperatives reacted with lightning swiftness to last year's government resolution in connection with PPC manufacture. When they were informed of the events they calculated that separately they had little chance of winning the competition and with a swiftness unparalleled in domestic practice they made a decision. Within two days, at the time of Orgtechnik '86, six small cooperatives and a trading firm agreed to form a developmental deposit association with legal entity rights.

This was probably the quietest but most significant event of the Orgtechnik conference.

The joint entry of the members of PerComp--the Instrument Technology, Microsystem, Controll, Data Manager, Applications Technology and Szamsov cooperatives and Hungarocoop--had convincing strength. The seven of them held more than 60 percent of the domestic PPC market last year. Their total turnover was on the order of a billion forints.

Our photograph was taken on the occasion of their first public appearance together. In February the Federation of Budapest Machine and Chemical Industry Cooperatives held a joint exhibit at which PerComp held a professional day. The member cooperatives carefully displayed "Member of PerComp" at their stands.

The OMF [National Technical Development Committee] competition makes it possible for them to produce 800 computers; they will divide manufacture and sales among themselves according to an internal agreement. The combination goes beyond this volume, partly because this is useful and partly because the development of a manufacturing base was a condition of the competition. We have no precise information about the final site but it is probable that the initial card level assembly will be followed this year by element level manufacture.

There will admittedly be a profit even on the small batches due to the competition. But much more important than this is the intention to hold on to

the associated trade--systems, equipment and software which can be sold with the machines. The prices of the units of additional manufacture planned, almost four or five times as much, may vary from member to member but it is certain that they will be well below last year's price level.

So the Economic Committee resolution has had an interesting consequence. In addition to having, almost certainly, permanently lowered the domestic PPC prices, we have witnessed a rare, swift and spectacular episode in the concentration of resources and assets. The small cooperatives, so often scolded and considered unreliable, have shown how one must decide and act in a difficult situation. And they have done so in such a way that it seems that fruitful, market oriented cooperation by participants and subcontractors otherwise completely independent, thus preserving their flexibility and dynamics, will be more probable in the future than cartel like actions.

So PerComp must be reckoned with already.

8984

CSO: 2502/50

HUNGARY: SUPERIOR TELEPROCESSING CONTROL

Budapest COMPUTERWORLD/SZAMITASTECHNIKA in Hungarian No 5, 11 Mar 87 p 4

[Text] The communications control equipment which has entered zero series manufacture at the Telephone Factory can be used advantageously primarily in teleprocessing applications of ESZR [Uniform Computer Technology System] computer systems. The significance of the TCT 3720 (its ESZR code number is ESZ 8372) is first that it replaces import of the Polish and Bulgarian ESZ 8371 equipment used for the same purpose and second that--according to the manufacturers--it can do more than the previous equipment:

- it has an 8 bit computer to expand diagnostic possibilities (journals, printing, etc.);
- it has type 2 and 3 line controls (scanner);
- it has two types of channel adapter (types 1 and 4);
- it can be connected to X.20 and X.21 line switched postal data networks (the Nedix network of the Hungarian Post Office); and
- it takes less space than other corresponding units in socialist countries.

Its chief characteristics are: it is suitable for handling 64 lines; it can operate according to start-stop, synchronous, BSC and SDLC protocols; and its transmission speed can extend from 50 bit/s to 64 kilobit/s.

The equipment is compatible with the IBM 3705 teleprocessing control unit, so one can connect from the side of the machine to the multiplex and selector channels of IBM computer systems. The Telephone Factory is also providing software products for the teleprocessing control which make possible network and emulation operation. We are informed that early shipment of ESZ 8372 prototypes to the Soviet Union has begun. Although series manufacture will begin only at the beginning of next year the factory is already accepting domestic statements of need.

8984

CSO: 2502/50

HUNGARY: AGRICULTURAL COMPUTER ASSOCIATION

Budapest COMPUTERWORLD/SZAMITASTECHNIKA in Hungarian No 5, 11 Mar 87 p 4

[Text] The so-called Teszov Cooperation, a computer association of six county producer cooperative federations, falls somewhere halfway between organizations formed to develop hardware and software and the end users. The cooperation, established in 1981 under the guidance of the Fejer County Teszov [producer cooperative federation], undertook the task (and received for this nearly 5 million forints in MEM [Ministry of Agriculture and Food] support and almost as much as an OMFB [National Technical Development Committee] loan) of coordinating developments with a small expert staff of its own, of developing user systems which were uniform in hardware and software by bringing in subcontractors and of putting these into operation in more and more agricultural producer cooperatives.

When reviewing the activity of the microcomputer association at the end of the first month of 1987 the presidium of the Fejer County Teszov could, in a certain sense, only record a "halfway" stage; the cooperation has traveled only half of the path planned an ample 5 years ago. One program package has been developed from the software prepared thus far which solves, in a uniform system, fundamental management tasks, providing addressed and precise information about the status of management. At present these programs operate in 24 producer cooperatives and additional users are expected to join this year. The figures are imposing in domestic practice but they do not reach the hopes formulated at the time the cooperation was formed. The relatively restricted user circle is explained by the devaluation since then of the VT-20 computer originally chosen and by the appearance of new, cheaper microcomputers, but the causes include independent developmental efforts by the federations and producer cooperatives. The spread of the system was also restricted by the fact that introduction of the systems takes an awful lot of energy, work and time, and frequent revisions become necessary because of changes in the regulators.

One cannot turn back if one has come halfway; the degree of freedom for decisions is reduced. The cooperation has obligations to the users of VT-20's thus far but at the same time it is slowly becoming impossible to put off the inclusion of PC compatible machines in the joint developments. It would surely aid a choice among possible paths forward and facilitate further progress if the producer cooperatives would concentrate their resources even more broadly,

if at least those federations which have not yet started independent development work would join in the cooperation. And finally it should not be necessary to develop anew in other parts of the country those systems which are proving suitable in Aba, Acs, Bajna, Besnyo, Dunaujvaros, Gyermely, Igal, Kocs, Martonvasar, Mocsá, Nagybajom, Sarkerestur, Seregelyes, Szekesfehervar, Ujpetre and another dozen or so locations.

8984

CSO: 2502/50

HUNGARY: COMPETITION TO PROMOTE ELECTRONIFICATION ANNOUNCED

Budapest COMPUTERWORLD/SZAMITASTECHNIKA in Hungarian No 5, 11 Mar 87 p 4

[Text] The National Technical Development Committee (OMFB) announces a competition for an accumulation tax concession which can be offered to acquire certain devices aiding the adoption of new electronic technologies and the electronification of production. The goal of the competition is to accelerate electronification and in the interest of this goal to moderate the capital burdens of enterprises using some electronic technologies and devices. Thus-- on the basis of point 3, Appendix 4 of Ministry of Finance decree No 32/1984 (XI. 5.) PM as modified by Ministry of Finance decree No 40/1986 (X. 31.) PM-- an accumulation tax concession can be granted at the request of participants to support adoption of new electronic technologies in the areas of flexible manufacturing cells, automated designing-manufacturing work stations, modern robotized solutions, hierarchic automatically controlled systems and devices for computerized local networks and to support acquisition of certain devices aiding the electronification of production by managing organizations listed in the industrial, agricultural and forest management branches of the economy for the acquisition of electronified products and electronic products built into electronic and electronified systems.

The tax concession can be applied to devices, machines and instruments acquired and accounted for in 1987. The accumulation tax concession can be, depending on the request of the participant and on the judgment of the competition, a full tax exemption or a determined ratio of reduction in the accumulation tax.

More detailed information in connection with the competition will be provided by department chief Istvan Levai in the Secretariat of the Electronification Economic Development Program at the OMFB (OMFB, Budapest 1052, 8 Martinelli Square, telephone 173-144).

Proposals must be submitted in four copies to the EGP [Electronification Economic Development Program] Secretariat of the OMFB (Budapest V., 8 Martinelli Square, postoffice box 565.1374) by 31 March 1987 in the first instance or thereafter by the last day of the several quarters of 1987.

The time limit for evaluation of the competition is 15 May 1987 in the first instance and 30 days following the quarter thereafter.

8984
CSO: 2502/50

HUNGARY: DOMESTIC COMMODORE-64 PEER NEEDED

Budapest COMPUTERWORLD/SZAMITASTECHNIKA in Hungarian No 5, 11 Mar 87 p 8

[A letter to the editor from Peter Matyas, Budapest: "Should We Support Taiwan?"]

[Text] One can learn about practically everything in your paper but you have visibly distanced yourselves from the home and hobby computer category although the professional and economic background for these is just as interesting as for professional computers. I am better acquainted with the Commodore-64 computer (I am now sampling a Varyter). I know that it is now fashionable to look down on the C-64 but the fact is that I have been able to solve many tasks on one. Tasks I didn't even try on a Primo, for the lack of the necessary documentation.

I had to say this because in what follows I also will apparently attack the Commodore. But this is not my intention, rather I would like finally to see a domestically made computer at the Commodore level.

Many types of computers have been collected in the school of my oldest son. And I bought my son a Primo, but now I've been stabbed in the back. I hear that neither the HT nor the Primo will be manufactured any more. And the school waits in vain for the Videoton TV-Computers it has ordered. The most recent arrivals are a C-16 and a C-plus-4, but these are not compatible with anything.

Far from the school computer competitions and the multiplicity of domestic "computer developments" I do not entirely understand why this confusion. I know it is hard to get the manufacturers to sit down at one table but I also know that if this goes on the spread and use of computer culture in Hungary will--as it has so far--cost much more than in other countries.

I have been watching the scanty debates about this which come up here and there. But even so I have not received an answer to the most important questions. The basic argument of the schools is that the Commodore is cheaper than any domestic computer. But how can a Hungarian machine be cheaper if the parts have to be imported, if the background industry is as it is? In their school computer program the French did not choose Commodore, Spectrum, IBM or Apple, which are cheaper and more easily acquired by them, but rather a

machine of the French Thomson firm. The French government covered the difference in price.

And is it certain that the Commodore is cheaper? We give dollars or goods worth dollars for them! How much does that dollar cost us? Has anyone done a comparison on how many dollars a complete Commodore costs and how many dollars worth of parts would be needed for a Hungarian machine--honestly put together with honest abilities and services, produced with domestic intellect and work?

I know that these questions also apply to the market for professional PCs. It would be a simple, but obviously stupid, solution to the confusing situation if either Hungarian computer manufacture or the import of computers were stopped. A rational solution is a good bit more difficult. In my opinion a national school computer program or a state administrative computer technology program has repercussions for Hungarian industry, could contribute to raising it or, on the contrary, could lead to further corruption of it. The question of private and official import should be separated from this.

I mention the state administrative program because it appears that what happened in the case of school computers is beginning there now. The councils are getting Taiwanese PPCs with a 200,000 forint concession per unit!

These are my questions. How many Taiwanese computers are they going to support this way? With how many dollars are they going to support--Taiwan! As opposed to how many Hungarian machines--machines requiring development?

And finally, what am I to do with the Primo?

8984

CSO: 2502/50

HUNGARY: COBLAB, NEW VIDEOTON SOFTWARE EVALUATED

Budapest COMPUTERWORLD/SZAMITASTECHNIKA in Hungarian No 5, 11 Mar 87 p 13

[Unsigned Article: "Laboratory Test of COBLAB"]

[Text] This time we commissioned the experts and instructors at the Computer Technology Institute, in Szekesfehervar, of the Kalman Kando Electric Industry Technical College to test, evaluate and critically review a program system which has not yet really left the hands of the software development staff of Videoton; sale of it has just now begun. Our choice was justified by the fact that the VT-20 version of the COBOL development system was quite popular and since this is practically the only bridge over which the Videoton computers, of different power categories and different design, are compatible with one another at the user level we considered it probable that COBLAB, rewritten for the VT-16, VT-110, VT-160 and, naturally, other IBM compatible PCs, would also interest many.

At A High Level

COBLAB comes from the expression COBOL LABORATORY, since its godfathers wanted to indicate that more is involved than a simple interpreter or compiler program--this is a COBOL development system. Naturally a concrete language is the basis of this system too, and this is the second level (Level II) COBOL used to program microcomputers as defined by the English firm Micro Focus.

COBOL itself--at least the first level standard COBOL (the so-called ANSI '74 COBOL)--does not belong among the interactive languages. Those memories and experiences that COBOL permitted transfer of only one data line between memory and the console at one time were all acquired on machines larger than micros, mostly during batch processing. The appearance of microcomputers forced the developers to re-evaluate this view and make COBOL suitable for conversational processing and the simultaneous transfer of a screen's worth of data. The extended ACCEPT and DISPLAY instructions of Level II COBOL make possible:

- maintaining a conversational link during program execution,
- use of keyboards controlling the cursor for data input,
- display of elementary data and combined screens,
- erasing the screen,
- elementary and group level data input,

--explicit cursor positioning, and
--menu selection with cursor positioning.

In addition to screen management the Level II version (and thus COBLAB also) stands a level higher than ANSI COBOL in efficient use of the available memory area. The so-called paging aids segmentation of the main procedural part of the program. In the present case this means that depending on the size of the program 256 K byte blocks of memory go from and to storage automatically in case of need. One tool for the structured solution of more complex tasks is if we write independent source programs for certain parts and compile these independently. Then if we no longer have need of a subprogram called by a CALL instruction during execution we can free the "pages" occupied by it with a CANCEL instruction.

Another tool for economical utilization of the memory area is the terse, intermediate code produced by the compiler and then interpreted by the executive system. The COMP translation directive is another possibility for saving space; under its influence the arithmetic instructions pertaining to PIC 9 (2) COMP and PIC 9 (4) COMP depicted data are turned into a more concise code. (The compiler does not do this automatically because in case of runover the code produced in this way behaves in a non-standard way.)

In addition to the many good properties we must mention one limitation of COBLAB--we cannot call machine code routines from COBOL programs, which would very likely improve the utilization of space.

Good Format Is Obligatory

An optional element of COBLAB is FORMS-2, which is an efficient tool in the hands of the user when composing screen plans. It may be excessive to use an independent tool so that a record appearing on the screen should have a good format but a screen plan planned and checked with the aid of FORMS-2 and stored on disk also spares the programmer the data description part of a COBOL program, and FORMS-2 is also capable of generating a maintenance program for created index sequential files. Roughly speaking the most boring and time consuming parts of COBOL programming solve themselves, and become more reliable at the same time.

A person may think that something so good should not be called an option, make it obligatory. But Videoton has a democratic spirit and prefers an indirect approach. For example, in the version of the development system studied by us we did not find the SORT and MERGE functions. Without them one can hardly realize a data processing task with sequential files. We were forced to operate with the index sequential file organization suggested by FORMS-2. Of course the user could give up the sure screen planning of FORMS-2 and write his own data description and file maintenance programs. Where ANIMATOR or tracing similar to the standard language DEBUGGING function operates it is no problem to debug these programs. But here there is no ANIMATOR and every other tool for tracing is missing as well; in searching for errors the user is left to his own circumspection and ingenuity. But he who is circumspect will leave everything possible to FORMS-2.

Errors and Error Signals

So we are on our own in finding semantic errors, but it would be unjust to the system if we did not mention that it does offer effective aid in discovering semantic errors. The compiler indicates with an asterisk in the faulty line the instruction or data it cannot interpret and with the error notes which can be found in the operator's and reference manuals this appears to be sufficient.

It is unfortunate that a similar checking system was not available to the authors of the manuals in order to at least put an asterisk by the hideous spelling errors and conceptual and illustration mistakes. It is true that even then some sort of tracing is indispensable for avoiding semantic errors, but it is enough to study the instructions in the Beginner's Guide to find statements which contradict one another.

The reference manual cannot be used as a textbook, but it does achieve the goal it sets for itself, to introduce those who know the COBOL language to the mysteries of Level II COBOL, with an understandable formulation of the necessary information and an index of names and subjects which can be reviewed. Our objections apply rather to the two operator's handbooks; here not only did we feel a lack in the information conveyed but we also missed helpful indexes.

Of course the developers indicated that these handbooks should not yet be regarded as the final versions, nor should the price which we can quote today. It appears that the COBLAB development system with FORMS-2 will not cost more than 90,000 forints. Before Videoton makes the final refinements it would be useful to test the sample programs which aid training well, and it would not hurt to compile and run one or two of one's own programs so that our data should be precise at least in certain areas.

There Is Time

It is well known that compilers for high level languages do not snap things up, but still we were surprised at the time data produced by COBLAB on a VT-16 supplied with one floppy disk store. We wrote a minimal program for this minimal configuration which loaded a 10*10*10 block using a three variable PERFORM. We confess that we found it too much that the compiler struggled with the 20 line program for 130 seconds.

Then we found it very little. When we started the compiler for a nonexistent program it took 80 seconds before it "discovered" that there was nothing to compile. Compared to this the remaining 50 seconds, when it did have to work, is a phenomenal time!

Of course the time data improves significantly if the configuration has hard disk background storage. We had already studied the executive system when we clocked the time on both configurations. Although there is only a memory operation in the above program the executive system was forced to turn to the disk unit, and this shows in the seconds; the 10*10*10 block was loaded in 71 seconds on the floppy disk configuration and in 28 seconds with hard disk.

(Out of curiosity we tried the program on an ESZ 1011 also where, naturally, there is no intermediate code and no executive system. There the running time was seven seconds!)

We also wrote a program where not only the executive system turns to the disk unit. We supplemented the writing to disk and reading back of a randomly loaded 1,000 record index sequential file by having the program delete or modify individual records on the basis of a key. Now also the hard disk run was about 2.5 times faster than the floppy disk run, 88 seconds compared to 216 seconds.

The tests showed that the longer the running time of a test program the less determining a factor was the time needed for the participation of the executive system.

Instead of a Final Word

Two fundamental properties of COBOL are task orientation and relative independence of the machine.

In this critique we tried to orient ourselves toward the task of evaluating the COBLAB development system from a viewpoint relatively independent of Videoton.

So our conscience is clear, we tried to approach our theme in an "adequate" way. We know that the reader may now cynically observe, "Yeah, but COBOL is high level." No matter. We served the ball for this cynicism and sent it high, or if you like, to a high level.

Report Card--COBLAB System; Vendor, Videoton; Hardware, VT-16; Price, 90,000 Forints Maximum

Performance, good
Documentation, weak
Learnability, good
Useability, good
Error management, satisfactory
Consultation provided, satisfactory
Price, satisfactory.

8984

CS0: 2502/50

HUNGARY: LINKS BETWEEN AGRICULTURE, COMPUTER TECHNOLOGY NEEDED

Budapest COMPUTERWORLD/SZAMITASTECHNIKA in Hungarian No 5, 11 Mar 87 p 24

[Article by Gitta Takacs: "Agriculture Seeks Computer Technology, Computer Technology Seeks Agriculture--Will They Meet?]

[Text] Agriculture provides 19-20 percent of our national income. Only 3 percent of our computers work in this branch. We get similar ratios if we compare the sums turned to computer investments or the numbers of computer experts employed to the national economic data. Considering its role and weight in the national economy, agriculture is disproportionately backward in the area of computerization and electronification.

According to data of the KSH [Central Statistics Office] there were two computers working in the branch in 1981, 111 a year later, 562 in 1985 and last year--according to a survey by the Statistics and Economic Analysis Center of the MEM [Ministry of Agriculture and Food]--there were 1,006. Their number increased 500 times in 5 years! The gross value of these computers was 65 million forints in 1981 and 737 million forints in 1985. Looked at this way the increase was hardly more than 10 times.

Numbers, forints, percentages, changes which appear large and small. Does agriculture need computer technology? Can we give computer technology to agriculture?

The spread of computer technology in our agriculture really began with the appearance of microcomputers. (Before them only the Ascota, Felix and other bookkeeping machines and batched data processing done at the SZUV [Computer Technology and Management Organization Enterprise] and on one or two "large" agriculture computers represented computer technology.) But the great increase in the number of machines in 2-3 years did not mean that their total power or capacity had increased so quickly. It appears from the cited surveys of MEM STAGEK [Statistics and Economic Analysis Center] that more than half of the machines now operating are personal computers with very limited power. The Commodore-64 is the only widespread type.

Opinions are divided about the effects of the Commodore fever. At the foodstuffs economy section of the Szolnok NJSZT [Janos Neumann Computer Sciences Society] congress Mihaly Voros, secretary of the agricultural

applications department of the NJSZT, summed up the experiences in connection with this thus: "The hobby computers caused the disillusionment of a large part of the purchasers because they overestimated their performance. But many were confirmed in the belief that many smaller tasks in the management of production units (animal raising sites, crop protection stations, etc.) could be solved well with them and that they could be used well in the preparation of leaders. So we consider it important that the managing units make use of the free capacity of computers already purchased.

"In general the experts of the software development firms speak very critically of homemade programs, about the lack of standard software and model systems. In contrast to this the agricultural organization experts argue that this tinkering should not be rejected unambiguously. Those farms where they wrote their own programs for a C-64 became cultured computer users substantially more quickly than the others, the uninitiated. These beginning experiences in forming a developmental strategy for information systems were fundamental for the enterprise leaders."

Disregarding the C-64s and their fellows the several hundred computers suitable for professional purposes represent more than a hundred different types. A good number of these fall in the category--to use the expression of one agronomist--of "it was a shame to buy it."

I do not think we would err if we said that there is hardly a more suitable area than agriculture for the large series spread of applications systems based on more or less uniform hardware-software elements. Even if we know that there may be large differences among the some 1,300 producer cooperatives. For example, their areas vary between 20 and 1,700 hectares, their number of workers between 60 and 7,000 and the per capita value of their fixed assets between 50,000 and 1.3 million forints. And all this, naturally, influences their approach to use of computers. But the management-accounting-data prescriptions or the biological foundations for fodder optimization or artificial fertilizer composition are similar in Szabolcs and Zala.

In any case, a good number of these many types of computers--difficult to compare with one another and only rarely compatible--went to the farms after the chief authorities, the professional-social organizations and committees within and between ministries established and included in documents the principle they proposed with the slogan "joint development--organized dissemination."

In recent years the producer cooperatives and state farms have been subjected to a veritable invasion. One after another the computer technology and organizational institutes tried, with great propaganda, to win marketing positions, not infrequently offering unsuitable hardware and deficient, weak software, with persuasive strength--and success.

The purchasers did not understand computer technology. In many cases they did not even have precise ideas about what they wanted the computers to do or how. The inexperience of the users played a role in the unsuccessful, impossible to use applications just as the dishonorable business aspirations of the organizations selling computers and developing software did.

"The multicolored nature of cooperative computer technology applications hides anarchy, making it appear as if there were a lack of coordination and prudence between the tools used and the organizational forms (organizations)... The number of machines keeps increasing, various imported and domestically made computers keep appearing, the program offerings grow, but the cooperatives are extraordinarily uncertain in developmental questions.... The spread of computer technology takes place within the framework of profit oriented enterprises, GMKs [economic work associations] and other organizations, and the cooperatives feel that computer technology is expensive, the price of services something they cannot check up on, the adapted systems frequently inoperable, or capable of being made operable only at the cost of much extra work and expense," it was said, among other things, at a meeting of the presidium of the National Council of Producer Cooperatives in October 1985.

Why do agricultural enterprises even use computers? Laszlo Kaszap (Agricultural Management Organization and Computer Technology Joint Enterprise) noted the following experiences, among others, in a publication of the fall Neumann congress: "The frankest answer may be that the bookkeeping machines have broken down and new tools have to be used in bookkeeping. It is very probable that no one would get into this not cheap undertaking simply because it is fashionable or because the neighboring farm has bought a computer. But we can find many cases where the investment began without any real user need, simply because the user was persuaded. A lack of conditions accompanies such cases and the painful progress follows from this."

What is most painful is the failure of users for causes outside their control. Unsuitable systems--with insufficient capacity and a weak technical level--can bring at best a "we didn't fail completely" result even for the most diligent and most conscientious users.

The 1984 survey of MEM STAGEK established that: "Enterprises belonging to the agricultural ministry plan to buy 700 computers by the end of the Seventh 5-Year Plan, 70 percent of them microcomputers. More than 400 farms--primarily producer cooperatives--do not intend to use computer technology in this period." In a STAGEK survey 2 years later the plans spoke of putting 2,500 computers into operation in the period 1986-90. And one might suspect that an even greater number might be shown by a survey taken after the promise of XT compatible PPCs for 130,000-180,000 forints and AT compatible PPCs for 195,000-260,000 forints as a result of the PPC competition announced in the wake of last July's economic resolution.

Will there be a "breakthrough" in agricultural use of computer technology in the next 1-2 years? Perhaps the most important of the many conditions for this is that there should be a suitable hardware supply; the farms--considering the excess of hobby computers--already know the applications limitations well. Capital is also a condition for development. The experts feel that the agricultural enterprises will produce even from narrowing resources the material assets needed for computerization, but they will require that state guidance direct the isolated developmental efforts and turn them into a proper bed by awarding central resources and with suitable regulation.

Agriculture is seeking computer technology. But our producer cooperatives, lacking sufficient expertise (a year ago, when the most recent statistical data were collected, only 700 computer technology experts worked in the branch, and more than 200 of them were data entry personnel), are hesitant, and they lack confidence after a few bitter experiences. They cry out for interest protection, for objective information and advice, and naturally they demand realistically priced hardware, useable software and competent service.

Computer technicians are seeking agriculture too, for this is a great potential market; if a bit mottled here and there it still counts as a blank spot on the map of professional computer applications and so offers good business opportunities. So the only question now is, Will they find one another?

Number of Computers	1975	1980	1981	1982	1983	1984	1985
Agriculture	3	2	2	111	209	380	562
(forestry, percent)	(0.5)	(0.2)	(0.1)	(4.2)	(4.2)	(3.5)	(2.9)
National economy, total	548	1272	1488	2665	4974	10708	19796

Gross Value of Computer Inventory (millions of forints)

Agriculture	10	58	65	247	465	747	737
(forestry, percent)	(0.1)	(0.4)	(0.4)	(1.3)	(2.0)	(2.7)	(2.4)
National economy, total	7669	15518	17047	19538	23261	27434	31030

Computer Technology Machine Investments (millions of forints)	Domestic machines	Import (ruble)	Import (dollar)
Agriculture and forestry, 1985	23	15	20
National economy, total, 1985	2175	714	885

Number of Computers By Category	Micro	Small	Medium	Large	Total
Agriculture and forestry	440	114	8	—	562
National economy, total	16587	2952	249	8	19796

Value of Computers (millions of forints)	Number of Computers	Value of Comp. Gross	Net	Net/Gross Value (percent)
Agriculture and forestry	491	639	371	58.1
National economy, total	19796	31030	13384	43.1

Sale of Applications Programs	Sales Receipts (1,000 forints)	
	First Sale	Repeat Sales
Agriculture and Forest Management	7061	441

8984

CSO: 2502/50

OLIVETTIS WITH HUNGARIAN CHARACTER KEYBOARDS PURCHASED

Budapest COMPUTERWORLD/SZAMITASTECHNIKA in Hungarian No 7, 8 Apr 87 p 3

[Text] Hungarianization of the Olivetti M19, M24, M24SP and M28--the entire professional PC offering--has been done at the Green Data AG headquartered in Vienna.

The Hungarianization of the popular IBM compatible personal computer (it was recently reported that 800 Olivetti PC's were coming into the country just through the winning of a State Insurance competition) can be done with a localizing kit which contains the new key caps, an EPROM containing the character set and a floppy disk from which one can load the Hungarian "keyboard driver" and the Hungarian "graphics driver." The Elektro-Coop Electronics Industry Cooperation and Development Enterprise is expected to sell the keyboard conversion kits, which adhere to the prescriptions of standard MSZ 7799/I.-82 one hundred percent, in Hungary.

In answer to our question the technical director of the Green Data AG said that after Hungarianization of the hardware the Hungarianization of the best known software products would follow. They hope to see to it that the Hungarian version of each famous software item will be just as correct and consistent a product as the German, French or Italian versions.

8984

CSO: 2502/57

SCIENCE PARK AT BUDAPEST UNIVERSITY

Budapest COMPUTERWORLD/SZAMITASTECHNIKA in Hungarian No 7, 8 Apr 87 p 4

[Article by K. M.: "A Silicon Valley on the Banks of the Danube"]

[Text] Silicon Valley is slowly becoming a common noun throughout the world. The common trait of the newer undertakings following the mystic model is that some regional community tries to entice into its own sphere of attraction undertakings having peak technologies. But the local goals differ and so accordingly do the tools used or the local historical development determining the concept.

For example, a few factors radically different from the European ones had a role in creation of the scientific-industrial parks of the United States. On the one hand the intellectual aura of the universities, in the shadow of which undertakings were born even earlier which grew into leading world firms since, was a given. At the same time a role was played by the climate, the tax level of the state in question, the mood of the environment, the character of the surrounding enterprises, etc. So industry goes where the engineers want to go, according to public opinion research done among researchers in the United States.

It can be seen from this that although innovation parks were formed abroad under the most varied organizational, formal and interest conditions not one model can be adopted unchanged due to the unique nature of the Hungarian economic and social environment. There is no domestic model, for only in recent years did plans to create Hungarian parks go into higher gear in the program to accelerate technical development and as one of the tools thereof. So even the parks already established in Szeged and Debrecen could not provide experience for the creation of a third at the Budapest Technical University.

But progress at the latter site has accelerated also.

In the first half of 1986 the Ministry of Industry and the National Technical Development Committee signed a general contract concerning the intent to establish an innovation park jointly. The profile of the park was designated as aiding industrial innovation by using microelectronic and mechatronic tools, relying to a maximum degree in this area on the intellectual capacity of the BME [Budapest Technical University].

A professional concept for the park was prepared at the university in June of last year and by December a group of experts commissioned by the Ministry of Industry had outlined their ideas pertaining to operational and organizational forms. Taking this into consideration a BME proposal was prepared and it was debated at the most recent session of the council coordinating scientific parks.

The proposal was described at the 18 February session by academician Robert Tuschak, scientific deputy rector of the BME. He said that--contrary to every foreign example--supporting domestic technical higher education, in regard to personnel and material supply alike, is based to a significant degree on the profitable exploitation of its research. The BME is no exception to this and for this reason it operates, to a certain extent, as an innovation entrepreneur. At the same time, the speaker emphasized, the university does not have the basic tools for peak technology, so it is not capable of serving the needs of these areas with its infrastructure.

Because of these characteristically Hungarian specialties the experiences in founding innovation parks abroad cannot be taken over unchanged, so for this reason also preparation of the proposal by the staff of the BME took a long time. According to the proposal described in February the Ministry of Industry, the OMF [National Technical Development Committee] and the BME would found a microelectronics and mechatronics scientific park at the BME. Later other members, such as innovation banks, might join the association, which would have independent accounting but would not have legal entity status. The purpose of the park, operating under university patronage, would be primarily support of industrial innovation with microelectronic and mechatronic achievements, but its operational area might also extend to other technologies which might develop on this material and intellectual base. But to realize these goals--we can read in the proposal--building on the existing tools of the university and supplementing them will require peak technology and technological investments which together with assets already existing will ensure or support--aided by effective operational regulations for the park--the creation of, among other things, integrated industrial manufacturing systems, wide use of automated engineering design, adoption of foreign achievements in peak technology, production in small series of individual instruments and intelligent devices and, in a word, the creation of machine industry and chemical industry technologies and the introduction of them into the production process.

The park to be established at the BME will be an entrepreneurial organization. According to the plans it will solve technical development tasks on order or on its own initiative and convert innovation ideas into products relying partly on its own laboratory established by the founders for this purpose but to a larger extent relying on an assets background primarily at the university but also brought in from other developmental sites, with an appropriate contract system.

According to the proposal the park will be open in regard to both those providing the ideas and those placing orders. Within an appropriate mechanism it will be available to any customer or entrepreneur under the same

conditions. In regard to its services the park promises more in four areas compared to the present innovation activity of the BME. It will offer the following: innovation market research, market organization and theme management by virtue of its entrepreneurial organization; small series ad hoc manufacture in areas falling in its profile; making its own assets available in areas where the BME does not have its own assets background; and venture capital with which it can independently finance projects or inventions judged profitable by the leadership mechanism of the park.

Because of the small number of personnel in the independently accounting, self-supporting park unit--according to the proposal--it will cover through agreements with outside institutions--primarily units of the BME--the capacity necessary for its research and development tasks which exceeds its own personnel and assets. Customers will pay for its services an amount set by the self-supporting costs and profit of the park.

So in whatever form it is created the park itself must, after the expiration of a transitional period following its formation, produce a profit covering amortization for renewal of assets, its own expansion and other obligations and all its operational, personnel and overhead costs. For example, if park developmental work is done with some university faculty and it provides only the managerial activity then the difference between the sale price attained by it and the developmental sum paid to the faculty must cover the managerial expenditures, the costs and the profit added to these. If, however, it makes its own assets available for the work then the profit margin must cover its own amortization and overhead costs.

Because of the unsatisfactory nature of premises and assets at the BME--among other things it completely lacks large capacity computer systems--founding of the park will require not only base area but also laboratory investments. The Ministry of Industry and the OMFb plan to make available 230 million forints for this, about one quarter of which will go to construction.

In addition it will be necessary to support operational expenditures while it gets started, at most until the end of the third year after completion of the investment, for these cannot be covered on its own in this period. The Ministry of Industry and the OMFb will provide about 30 million for this purpose. The contribution of the third founder, the university will be a site for the park with utilities, an infrastructural network, the economic organization, a library, etc. and an intellectual and material background which can be brought in to operate these, a background on the which the park will actually be built.

Foreign examples unanimously show that when founding parks they rely on some university, not only because of the intellectual background but also because they want to use the infrastructure developed in the interest of education and because the need for premises can be satisfied favorably and tax free in connection with a university. For us, on the other hand, about 70 percent of the investment costs for founding a park derive from the unfortunate Hungarian speciality that the BME is not adequately supplied with assets which can be used in precisely the technically most modern areas (computer technology, mechatronics, etc.).

It would be completely illogical--the proposal warns--to handle the investment needed to make up this shortage as a business undertaking. So for the time being the people at the university recommend a form for the park in which the investment will not be regarded as a taxable business and which does not represent automatically the production of profit and an obligation to pay taxes.

The proposal also turns in detail to the question of self-support, for after the transitional period the park must become self-supporting; that is, turnover must cover the amortization and overhead costs. It would not be realistic--the proposal states--for the capital invested to be paid back, especially not on a capital proportional basis. But after undertakings have been assumed one can imagine a sort of turnover proportional repayment, but only to such an extent as not to make prices unrealistic. So those preparing the proposal recommend that the founders not take out a profit or capital repayment from the park but rather leave it in for renewal and development.

The BME proposal also turns to guidance of the park. According to this a managing director, independent even in regard to the patron, should provide operational guidance while guidance in principle would be the task of a director's council. The members of this body would be representatives of the founders endowed with suitable rights; they would make the strategic decisions.

Following the 18 February session the council coordinating innovation parks submitted a recommendation to the minister of industry and the chairman of the OMFb regarding foundation of a scientific park at the BME.

8984

CSO: 2502/57

HUNGARY: LATEST VIDEOTON PRINTER

Budapest COMPUTERWORLD/SZAMITASTECHNIKA in Hungarian No 7, 8 Apr 87 p 5

[The text portion of an illustrated advertisement]

[Text] A line printer is one of the most critical elements of modern, large capacity computer systems. Knowing this Videoton has designed its line printer family, the most economical member of which is the B300 equipment which can be seen in the photograph.

Its speed of 300 lines per minute provides sufficient efficiency in most applications areas at a very favorable price--which also offers a good opportunity for multiprinter systems or systems equipped with a safety backup printer. Its well known reliability unambiguously raises it above others in its class.

Its small dimensions, easy connection and very long life ribbon ensure that users will experience in practice how a modern line printer works.

The B300 printer has all the properties which one expects from a line printer in a modern computer system.

Among other things:

- line length of 136 characters,
- adjustable page height and number of copies,
- a full function testing possibility (with the aid of a built-in autonomous unit),
- dimensions of 103 x 94 x 71 cm,
- active ribbon drive and fast acting hammer protection, which together result in significantly increasing the life of the ribbon.

8984

CSO: 2502/57

DATA ON ROMANIAN COMPUTERS AMENDED

Budapest COMPUTERWORLD/SZAMITASTECHNIKA in Hungarian No 7, 8 Apr 87 p 8

[Letter to the editors from Zoltan Biro, Mathematics-Physics Lyceum, Sepsiszentgyorgy]

[Text] A few things should be added to that part of an article titled "Home and School Computers" in your 28 January issue which pertains to Romania because the data published are not sufficiently exhaustive and do not completely cover the facts.

Prototypes of the first Romanian personal computers--the PRAE and the Allic, originally designed primarily for didactic purposes--were prepared during 1983 and they were shown at a scientific symposium in November of that year. (The author of the article does not even mention one of these types.) The machines were designed by the Kolozsvar [Cluj] and Temesvar [Timisoara] ITC's respectively; series manufacture of them could begin only in 1985 at the Memoria Factory in Temesvar. About a thousand of each may have been produced since then. (A few data about the machines: the central unit is a Z80, 16 kilobytes EPROM, 16-48 kilobytes RAM, 256 x 256 black-white graphics, built-in speaker, RS232 serial interface, monitor program, cassette interface; the PRAE has double precision BASIC containing fast graphics instructions; the Allic has a program package executing matrix instructions.) This same enterprise--jointly with the CCAB--also created a semi-graphic, CP/M compatible machine called the CE 119. Since 1985 interest in Spectrum compatible machines has been growing; there have been the TIM-S (Temesvar ITC), the HC-85 which was mentioned in the article (ICE-Felix) and the COBRA (Brasso ITC). Only a few of the latter have been made.

An attempt to realize a Romanian school computer program is being made with the above mentioned machines. Quite a few schools (including ours) and Pioneer Houses in the larger cities already have personal computers.

8984

CSO: 2502/57

HUNGARY: CSEPEL COMPUTER HERE TO STAY

Budapest COMPUTERWORLD/SZAMITASTECHNIKA in Hungarian No 7, 8 Apr 87 p 9

[Article by Janos Andor Vertes: "How Did The Boots Get On The Table?"]

[Text] Many did not believe their eyes at last year's Budapest International Fair when they saw that the Csepel Works also was already producing a computer! But it was difficult to doubt it. It was called the CS16 and to avoid misunderstanding it whistled "Red Csepel." Then a table appeared in the CW bulletin titled "compuTREND" and the CS16 was not left out--256 kilobyte central unit, 360 floppy disk, 27 M hard disk, 8 megahertz clock signal, color monitor, and all this for 430,000 forints, a price competitive with the others. "It will pass," many thought, "it seems everyone here has to get over computer manufacture sometime." But the CS16 was not omitted from the year-end table either. In the meantime a few, thinking of how budgetary institutions scatter money about in December, raised their prices. At Csepel they increased only the memory (to 640 kilobytes), and the December price was only 360,000 forints. The facts of the matter were not yet sensational; finally they also fit in among the two or three dozen PC manufacturers.

The bomb exploded in February when the OMFb [National Technical Development Committee] announced at a press conference who had won the competition announced to improve domestic PPC [professional personal computer] supply and the Csepel computer came in fourth, behind Videoton, the Proper Association and an association of six "soon-to-be-big" small cooperatives, coming ahead of SZTAKI Cosy [Cooperative Systems subsidiary of the Computer Technology and Automation Research Institute]. "Who are these people getting state support for the manufacture of 500 machines?" "The Csepel Transformer Factory and computer manufacture? How did the boots get on the table?"

So how did the boots get on the table?--we asked Emil Kindzierszky, chief engineer for electronics development at the Transformer Factory of the Csepel Works, manager of the factory unit increasingly better known as Csepel Electronic.

On The Ashes of the VBKM [Electrical Equipment and Appliance Works]

"In regard to its chief profile the Csepel Transformer Factory is active in areas which are not too favorable from the economical viewpoint. Do not

misunderstand, our products are sought after. For example, only three enterprises in the world manufacture dry geafol transformers, and since for safety reasons oil transformers cannot be used in a number of areas we have no problems selling them. Unfortunately, however, investment goods are import intensive, even if we produce for the domestic market, and it is well known that it is not easy today to produce conditions for import. While most managing organizations complain of manufacturers in monopoly positions a monopoly customer determines our partner contacts. By mid-1985 our problems prompted the enterprise leadership to decide that we had to stand on more legs, had to expand the profile."

Here the chief engineer stopped for a moment, like one who has reached the end of one branch of a process chart. Then he took a deep breath, as one who would tie another historical branch into the same block.

"The decentralization of the VBKM came as a godsend for the leaders of the Transformer Factory (I still do not understand it). Some of the profiles in the dismembered works became stepchildren, and since no one felt they were theirs the profiles (and the few experts belonging to them) looked for parents to adopt them. So electronics at the Transformer Factory is built on the ashes of the VBKM; three of us here began to outline the future in December 1985."

Ground Under the Feet

"Electronics was not too favorably received within the factory. Many feared for the old profile, others did not think electronics, much less computer technology, had a good foundation here. We also racked our brains as to how we could supplement or surpass the giant enterprises. One thing we set down from the beginning was that we had to develop a customer centric approach. The other thing was that we should not be ashamed to learn, to copy correctly."

Emil Kindzierszky made a little detour into the world of the "good old days" when adaptation or reproduction was regarded, in his earlier places of work, as a technical task at the same level as development. Then he became the reporter and asked a question in return: "Do you know why this practice ended? There was a serious reason for it."

After I had to confess that I did not know (indeed, I am not certain that it did end) my conversation partner, who has collected two engineering diplomas, himself put forward the thesis, which can be explained as a matter of engineering interest.

"The only incentive for development in Hungary today is a patent. And the fee one gets for a patent is connected to the price of the product. So it is in the interest of a Hungarian developer to design a parts cemetery. We do not pay for something if it is created on the achievements of others, and the incentive is not interconnected with the profit ratio."

Of course they may have discovered something at the Transformer Factory, for last year they manufactured a series of 300 of the CS16 computers which a few months earlier had been whistling the movement marching song, and they succeeded in selling them too. This is not yet a complete vertical operation.

Where it suffices they do not neglect to use an 8 bit microprocessor, but they are also experimenting with purely 32 bit (Motorola) systems.

"We found a way of cooperating with a developmental economic work association, Comproject, which in my opinion may be optimal from the viewpoint of both the large enterprise and the small undertaking. Series manufacture is made to order for the former but development is made to order for the latter. When the OMFb announced the competition we had just gone through a series of value analysis computations and we knew which of the elements we had developed ourselves we should keep and which we should import. The fact that they accepted our bid and that we got the support necessary for manufacture put ground under our feet; if we had not been accepted among the big ones we would have had to fundamentally change the entire concept of Csepel Electronic."

In Addition to the IBM Line

Of course the solid ground does not mean that everything will remain as it was. Emil Kindzierszky darted off this ground--even despite the restricted developmental resources--and designated three themes which might determine the future of Csepel Electronic.

"We also, like all PC manufacturers, see an expansion of the utility of professional personal computers in networks. But in addition to local networks we are trying to get into the area of global networks, for there are machines with various architectures on the market and there might be a user who would like to connect a VAX category machine to a PC, or would like to see VME devices in a network. In any case, in addition to the IBM line, we might characterize the second developmental direction with these other three letters, VME. We are talking about a system of tools for control and computer technology so many-sided that everyone who is developing in accordance with extraordinarily precise prescriptions may get into it. A VME club has been formed in Hungary which brings together manufacturing enterprises and research institutes. We would like it if we could find our place here along side the MMG [Mechanical Measuring Instruments Factory], Vilati, the KFKI [Central Physics Research Institute] and the SZTAKI. The third area is software, to which we are turning ever greater attention. Of the 60 people making up Csepel Electronic today 26 are dealing with software development. We know very well that if they were to draw the curtains on hardware today one could live on software for at least 20 years."

Let Us See the Boots!

So the CS16 was not a shooting star of multicolored Hungarian PPC manufacture but rather--it appears--it has won a lasting place in the Hungarian sky. If we think, for example, that Videoton got started with hunters' cartridges and continued with small motors then our question as to how the boots got on the table was not quite fair, for sooner or later every large enterprise feels the pull of the so-called "driving branches" of industry. In any case the present situation is that in 1987 an eighth of the 4,000 PPC's outlined in the OMFb competition will be made at Csepel. A PC without hard disk will cost 121,000 forints; the price of an XT will be 159,000 and the price of an AT will be 213,000. The basic configuration of an XT will be a 640 kilobyte central unit,

360 kilobyte floppy disk, 27 megabyte hard disk, monochrome monitor and an MS-DOS version according to need. The central unit of an AT is only 512 kilobytes and the monitor is color. The power unit--it is suitable to end the report with this at a transformer factory--in every configuration will be Hungarian and will meet all MEEI prescriptions and standards.

8984

CSO: 2502/57

HUNGARY: SMALL COOP PLANS LARGE SERIES COMPUTER PRODUCTION

Budapest COMPUTERWORLD/SZAMITASTECHNIKA in Hungarian No 7, 8 Apr 87 p 14

[Unattributed article: "In the Service of Large Series Domestic Manufacture--What, Why and How?"]

[Text] Approximately 5,000-7,000 IBM compatible professional personal computers operate in Hungary today; year after year the number of them increases by more than 100 percent and the market is expanding. Predictions for 1990 mention 50,000 PPC's [professional personal computers]. The Instrument Technology Small Cooperative, already playing a significant role in several branches of the computer industry, intends to manufacture nearly one fifth of this volume each year.

The leaders of the small cooperative understand that manufacture at such volume is unimaginable without corresponding production capacity. To realize their plans they are carrying out on their own--since they get no state support--an investment worth about 100 million forints. Even in 1987 their growing manufacturing capacity will make possible manufacture of 2,000 PPC's and 5,000 terminals. Their goal for later is production of complete PPC's (2,000 to 10,000 units per year) and subassemblies in a series size unexampled in domestic practice.

Such a series size and the investment of such a sum is already equal to a confession of faith, that it is possible to manufacture PPC's profitably in Hungary even if a very spectacular price reduction has taken place in this category in recent years. Instrument Technology is planning for the long term--and is urging domestic manufacture for this reason--and it follows a flexible price policy. (As of 16 February it moderated the price of some of its computers by 30-50 percent.)

This is also the answer to the question of why they chose increasingly complicated manufacture and not some easier path. They also knew of those dubious paths for making a quick profit which might represent an apparent solution on the domestic market. We are thinking here of the import of cheap Taiwan machines, which has a spectacular result in the short term and promises a good bit greater profit than starting up manufacture. In addition to the "manufacturer" the user also doubtless profits from this apparent solution. But he is also the one who could lose the most--his problems are not all

solved by getting a machine at a relatively favorable price (if he can get one); continual, reliable quality are not guaranteed for the basic machines or for further expansions, nor is there any guarantee of resupply of spare parts. Instrument Technology offers security to its potential customers.

Naturally they also are trying to make a profit, but in the opinion of the leaders of the small cooperative giving up manufacture--whether partly or completely--hurts Hungarian industry as a whole; not only does our backwardness compared to Western European and Far Eastern technological development increase further but the entire background industry remains untouched. What could make Hungarian products competitive on domestic and Western markets alike is quality, reliability and an acceptable price. The reservations in connection with the Taiwan machines are based on uneven quality, and the Hungarian computer technology industry could exploit this--the Hungarian machines should be sold with Western European quality at Taiwan prices. That this is not some sort of unrealistic dream is sharply illustrated by the Western export of the small cooperative. Even now they can ship some special expansions to the FRG and Austria at a profit, and not just to generate dollars. And if they succeed in getting a foot in the Western market--and the results permit this conclusion--then in all probability the Eastern European users will turn to them with increased confidence as well. Because the computer industries of the other socialist countries are struggling with import problems similar to the Hungarians. So finding a relatively cheap manufacturer who is reliable over the long term is just as important for them.

There is a fundamental conviction at Instrument Technology that the possibilities in Hungary meet the technological demands made by manufacture of PPC's. Hungarian industry has the reserves, the relatively cheap manpower and the expertise which can result in competitive prices and reliable quality. But to achieve this there must be a strengthening of our own manufacture as opposed to purely--more or less--commercial transactions. They support their arguments partly with their own surveys and partly with the Taiwan example--in that distant island country a number of small enterprises manufacture PPC's in series of 5,000-10,000 units, at a profit, even though a few years ago computer technology was a virtually unknown concept for them.

As a member of the PerComp association the Instrument Technology Small Cooperative was also a winner of the OMFB [National Technical Development Committee] and OAAH [National Materials and Price Office] competition. The six small cooperatives received import support to produce, altogether, 800 PPC's, which, naturally, is only a part of the total amount to be produced. They feel that the organs mentioned did not award the money for the purpose of buying complete PPC's but rather to start up domestic large--relatively large--series manufacture. They hope that in the long run--striving initially for smaller profit--the central support will put domestic manufacture in the foreground in every area, because only this can exercise a driving force for the Hungarian computer industry and background industry.

They trust that the domestic small, medium and large enterprises will also recognize the importance of domestic computer technology manufacture and the fundamental national economic interests therein. In their opinion the healthy

competition thus developing is the way to bring the Western European markets closer to Hungarian manufacturers. And a quality suiting the Western market will also suit the Hungarian user.

Starting IC level manufacture figures in their plans for this year and in the longer run--cooperating with the Communications Engineering Cooperative--they propose wafer level PPC manufacture, in agreement with the members of PerComp.

The New EASTSTAR

Naturally PPC manufacture is only one part--although one of determining significance--of the manifold activity of the small cooperative. The EASTSTAR minicomputer family, which is offered primarily for large enterprises, represents a level a category higher. The newest member of the family preserves the virtues of its predecessors and expands the possibilities provided by this category.

The new EASTSTAR will be shown to interested parties at the April MIPEL exhibit and at the spring Budapest International Fair. There has been significant progress compared to the 16 user systems of earlier versions--the new machine makes possible coordinated task execution by 64 work stations. Every element of the multiprocessor architecture is an Intel 80286 and the intelligent terminals belonging to the configuration have their own processing and storage capacity (one can also use IBM PC, XT or AT or compatible computers as intelligent terminals). The link between the central EASTSTAR computer and the terminals is realized over a coaxial cable; a transmission of 2.5 million bits of information per second is possible. The number of connected work stations can be multiplied by connecting several EASTSTAR machines into a network.

The operating system selected and the software available are crucial elements for every computer. The operating system of the new EASTSTAR is compatible with MS-DOS 3.1 and the basic software itself is suitable for the multi-user mode. In the software area the EASTSTAR is characterized by IBM compatibility--now virtually obligatory--to such a degree that program packages developed for IBM PC's can run on it, such programs as the dBASE III plus data base management program, MBASE + or TURBO Pascal. So users can solve their increased tasks on the new machine building on earlier practice. The new generation of EASTSTAR machines is characterized by increased processing capacity; the maximum operating memory is 8 megabytes, it has 1.2 megabyte and 360 kilobyte floppy disk units and a large capacity hard disk (Winchester). It is possible to connect color work stations and a number of printers. The Instrument Technology Small Cooperative offers the new machine primarily for large enterprises but it is also suitable for performing the increased tasks of smaller organizations.

Networks

It is clear to every user that the key elements for network operation are the network control programs and coupling units. Instrument Technology recommends the most modern and most reliable of these. It is not by chance that the

products of the small cooperative, in addition to complete systems, include these as elements which have won the highest rank.

The control tasks of the coupling unit are taken care of by its own RAM memory and an intelligent processor; data transmission speed is 2.5 megabits per second; that is, information corresponding to 2.5 million bits per second can be carried by the network. The several work stations--which can be a maximum of 6.5 kilometers apart--are connected to a common bus. The maximum of 128 work stations can be distributed individually or in groups; a standard 75 ohm coaxial cable serves to connect them. The network coupling unit is compatible with the ARC-NET which has spread most spectacularly throughout the world recently. Using a network within a certain size the transmission speed of the ARC-NET network card practically corresponds to the access speed of an IBM PC/AT hard disk, so in regard to the price/performance ratio it can be called optimal in small or medium size networks.

A number of West German and Austrian enterprises which use the Novell networks buy ARC-NET compatible coupling units from Instrument Technology; the card made by them is a good bit cheaper than the original ARC-NET. These network cards will contribute considerably to increasing the 1987 export of the small cooperative.

The Novell NetWare program packages ensure high level network operation. Their operating systems are PC-DOS/MS-DOS 2.0 through 3.2. The individual work stations of the fast network can access common large capacity Winchester and printers; data transmission can be ensured twice. The dBASE III plus and MBASE + database management systems can be connected to the network control programs. The possibility of a permanent "hot reserve" ensures data protection and protection against errors.

The networks being sold by Instrument Technology today are among the most sought after articles on the computer market. This is based on the high quality, the favorable price and the service base (service, training, preparation of turnkey systems) on which these networks rely at the small cooperative. The technological and manufacturing background described in the introduction are long-term guarantees for new users too.

In the year of its formation, 1981, the sales receipts of Instrument Technology were under one million forints. They ended last year with receipts of 600 million forints and will probably reach on the order of a billion in 1987. And they are doing all this with a nearly constant number of personnel and with constant price reductions.

8984

CSO: 2502/57

HUNGARY: INTERVIEW ON FUTURE OF ONLINE DATABASES

Budapest COMPUTERWORLD/SZAMITASTECHNIKA in Hungarian No 7, 8 Apr 87 p 16

[Interview with Peter Jacso, chief of a main department in the Computer Technology Applications Enterprise, by Huba Bruckner: "Will We Remain On Line?"]

[Excerpts] The most prestigious event for the online information industry was held for the tenth time at the end of last year in London, the International Online Information Meeting attracting more than 5,000 participants from 32 countries. Our country was represented by 15 people, which in itself indicates the Hungarian interest in online information services. (In addition to our country the socialist countries were represented by one person each from the Soviet Union and the GDR.) Traditionally at the closing plenary session they review the status of the profession, the achievements, failures and expected developmental trends--in the light of what was heard and seen at the conference. On this occasion one of the three asked to give his opinion was Peter Jacso, chief of a main department in the SZAMALK [Computer Technology Applications Enterprise]. We also waited for his answers to similar questions.

[Question] In regard to compact disks. They are predicting a stormy success for this technology, which makes possible unerasable storage of 550 million characters of textual information on an optical disk about 12 centimeters in diameter. The necessary player costs about 1,000 dollars. It can be connected directly to a personal computer and with the database they sell information querying software which in its capabilities is not at all behind the command languages used at the big online centers. Annual rental of compact disk databases is between 1,000 and 4,000 dollars. Because of the expected quick spread of this technology many are tolling the tocsin over the head of the online information centers. One speaker expressly styled the compact disk as the hump on our back.

[Answer] A few providing centers really may feel that the bell is tolling for them. Especially those which offer access to only a few databases, perhaps just those which have also appeared on compact disk. But this competition does not really bother the large service centers. They themselves are getting into this business, emphasizing that optical disks only supplement the traditional online services with which one can query not only one database and a restricted time interval therein but rather going back many years.

It is easy to calculate when a CD-ROM version is worth it. If, for example, a compact disk containing the bibliographic entries of the Computer Database between 1983 and 1987 were to cost 3,000 dollars and we at SZAMALK used this database, let us say, for 30 hours a year, then we would buy the disk because today the hourly fee for online use of the database is about 100-110 dollars. We must add to the cost data transmission, which is very expensive for us, and the fee for printing out the hits. And if we bought the disk then obviously we would use this database more intensively, because the extra use would have no extra cost and thanks to the laser beam the disk does not wear out. The compact disk databases represent great possibilities for precisely those countries which are less developed industrially and infrastructurally where data transmission is backward and therefore expensive. For us, today, the data transmission fees make up 40-50 percent of the foreign online query costs, but make up only 8-10 percent in the United States.

[Question] But will not the players and the disks be classified as embargoed products?

[Answer] I do not think they will be. Manufacturing them still requires peak technology but their passive use does not, and in the near future we will be only users of the disks. Of course, those databases which so far could be queried only by American, Canadian and/or Western European users will not be sold on compact disk in the disk shops either.

[Question] And Hungary? What is the situation here, where do we stand, where are we going?

[Answer] The possibilities we have talked about thus far are for the most part attainable here, but our position is not good. Mihaly Agoston, director general of the OMIKK [National Technical Information Center and Library], said recently in a radio interview that in online query time per capita the United States can claim 500 times as much and Austria 50 times as much as Hungary. This ratio--which speaks for itself--is much worse than the infamous situation of our telephone supply. It is in vain for us to have at the OMIKK, IPIKK, SZTAKI [Computer Technology and Automation Research Institute], KSH [Central Statistics Office], OT [National Plan Office], MNB [Hungarian National Bank] or SZAMALK better and better information query experts specialized for some theme or database type, in vain for Technoinform to get a quick use password for some new providing center, if the demand for these services does not grow, if only a very few understand that immediate information is power and market value, even if it is difficult to express this in forints in every case. Use should be made much more frequently than at present of theme bibliographies, current theme monitoring, foreign market statistics or company information before research and development work, manufacturing activity or even business discussions.

The compact disk databases are very interesting for us. Already one can get 60-70 databases in this form, and in a surprising way the majority of these are on social science areas (education, sociology, library and information science databases).

Technical and natural science databases can be expected shortly.

[Question] So, in the light of this, is there a future for online information services?

[Answer] Certainly, and probably we will be able to make use of them not only as users of foreign developmental achievements and products. Preparations are under way now in a number of large computer technology and information centers for joint design, development and operation of a domestic online information system which will probably start operation at the end of the decade.

8984

CSO: 2502/57

HUNGARY: EXPERT SYSTEMS AND ARTIFICIAL INTELLIGENCE

General Overview

Budapest COMPUTERWORLD/SZAMITASTECHNIKA in Hungarian No 7, 8 Apr 87 p 19

[Article: "The Situation in Hungary"]

[Text] In Hungary expert systems typically belong among those areas in which there is a realistic possibility for real world market progress. The trend is a rather recent one, even abroad relatively few are competent in it, so in theory the situational advantage represented by the existing strong theoretical foundations (AI, logic programming) could pay off well. Still the domestic status of the theme shows a uniquely two-faced nature. What is gratifying is that the research and development work, grouped around a few bases (SZTAKI [Computer Technology and Automation Research Institute], SZKI [Computer Technology Research Institute and Innovation Center], SZAMALK [Computer Technology Applications Enterprise] and the KFKI [Central Physics Research Institute]), is being conducted intensively. A few of the themes are expert systems already realized or nearing completion--diagnosis of perinatal brain damage of infants, diagnosis of diabetics, computer configuration, etc. Outside institutions (hospitals, universities) provide the expertise, so the common work can also dispel the possible aversion or distrust of expert systems in professional circles.

It is unfortunate, however, that information flow among the developmental sites is much more lax than desired and forums for professional meeting are rare. Among the problems one might mention the fact that the Hungarian language professional literature is not rich enough and sometimes a lack of terminological clarity causes problems.

Machine Industry Applications

Budapest COMPUTERWORLD/SZAMITASTECHNIKA in Hungarian No 7, 8 Apr 87 p 20

[Article: "Ikarus and Milacron"]

[Text] Building a bridge between the real engineering problems of machine manufacture and the tools of artificial intelligence is the concern of Jozsef Hatvany and the research group led by him at the MTA SZTAKI. They are

systematically surveying every aspect of mechanical engineering practice, the existing and missing tools and the characteristics of engineering activity. They use the "menu" thus obtained to create expert systems. Using the example of designing devices from modular elements they have succeeded in showing that they can create useful applications out of rule based software systems. They have produced software which aids optimal placement on a pallet of workpieces for milling machines or processing centers or which aids flexible variation of devices to accept frame elements in the welding of autobus frames.

"In the course of realization we came to the conclusion that in the development of systems aiding machine manufacture one of the most complicated parts is the correct determination of the hierarchy of goals. To a crucial degree a strategy of progress on rules is determining in this," said Jozsef Hatvany.

"The program uses a large number of empirical rules or knowledge; following a determination of the geometric data for the workpiece it recommends alternative device solutions. The engineer can select among these (or reject them), then the program prepares complete documentation for the device." Development began within the framework of an OTKA [National Scientific Research Fund] competition. As a result of the work of the group thus far, building also on the Hungarian PROLOG school and the expertise of the Machine Manufacturing Technology Faculty of the Budapest Technical University, a system to aid device design is already used at Ikarus and the American Cincinnati Milacron machine tool manufacturing enterprise is designing clamping device elements for pallets for milling machines using a version which runs on an IBM PC.

Great interest and receptivity for the results, which can still be called initial results, have been shown in the FRG, Japan and the United States but unfortunately only little interest has been shown here at home. But the time of the old factory "pro" who knows it all is running out there as well as here and use of the expert systems which will take their place becomes increasingly urgent.

Developments in MPROLOG

Budapest COMPUTERWORLD/SZAMITASTECHNIKA in Hungarian No 7, 8 Apr 87 p 20

[Text] In November of last year the department of the NJSZT [Janos Neumann Computer Science Society] dealing with artificial intelligence and form recognition invited to a conference those who are developing expert systems in Hungary.

In the course of preparing for the conference, which aroused great interest, the secretary of the department, Mrs Edit Toth Santa (SZKI), prepared a summary of expert systems using the MPROLOG language. It appears from this that most researchers are preparing medical, primarily diagnostic, expert systems. Janos Aszalos and Judit Talyigas described three such developments in the first 1987 issue of COMPUTERWORLD/SZAMITASTECHNIKA.

Tibor Deutsch has participated with the SZKI, and naturally jointly with medical experts, in developing several medical expert systems at the Computer Center of the SOTE [Sommelweis Medical University].

Of these a restricted version of a system seeking the antibiotic most suitable for overcoming a bacterial infection is already in operation; they are now expanding the knowledge base with physicians at the Sandor Peterfy Street hospital. The program called DIATHERA is the nucleus of an expert system supporting the planning of therapy for diabetics; it was developed on a C-64 by the SOTE Computer Center jointly with the First Internal Medicine Clinic.

In addition to the above they are working on a query and consulting expert system for medicine interactions at the SZKI. Mrs Klara Zarandy Konc and her colleagues from the National Pharmacology Institute are participating in this work.

At the Construction Sciences Institute they are preparing, under the leadership of Dezso Holnapy, an expert system for soil mechanics studies connected with building supports.

At the Szeged Biology Center they have already prepared for the SZKI an expert system analyzing amino acid and nucleic acid sequences.

The hunting ground for those dealing with expert systems has spread to computer technology itself. Enthused by the success of an American system configuring the VAX 11/780 the SZKI is developing a similar service for Siemens customers.

Probably the confusion reigning in the area of computer networks motivated a joint project by the KFKI, the Postal Experimental Institute and the SZKI the goal of which is development of an expert system to specify and test network protocols.

Council Administrative System

Budapest COMPUTERWORLD/SZAMITASTECHNIKA in Hungarian No 7, 8 Apr 87 p 21

[Text] In our 1 February issue we reported briefly that at the MTA SZTAKI they had begun development, under the leadership of Tibor Vamos, of an expert system to aid council administration. One goal of the research is to offer new possibilities for citizens to check on public administration procedures and to increase the "transparency" of these procedures. In the goals of the system they make a distinction from the customary computer aided legal advice function because they are not so much replacing a legal expert as providing a direct tool for conducting a dialog with the council public administration system. It should support primarily the actions of citizens and their relationship to state administration. The other goal is to spread the methods and experiences found in knowledge organization and expert systems to applications areas which are as different from one another as possible. As a first experiment their goal is to provide orientation in the authorization procedures for construction and to solve visitation problems in the case of divorced parents. It is an open question whether the system will understand

natural language or use fixed text aided by dialog. Something still fundamental is the similarity of patterns as cases to procedures handled as precedents. This requires a special decision field and measuring system. The first application of basic research results on PC's the size of AT's can be expected within a few years.

8984

CSO: 2502/57

HUNGARIAN, SOCIALIST COMPUTER MARKET IN 1986

Budapest COMPUTERWORLD/SZAMITASTECHNIKA in Hungarian No 7, 8 Apr 87 pp 26-27

[Article by Peter Broczko: "The Domestic Market in 1986"]

[Text] Something new last year was the development of a buyer's market in the area of microcomputers, and a significant drop in prices as a result. We examine the domestic microcomputer market by performance category, for it is in accordance with this that we have different ages of the machines, different times in their life cycles, different sales volumes, customer circles and rate of price changes.

The Professional 8 Bit Machines

The volume of domestic trade in these reached a peak in 1984 and has been gradually declining since. The number of them sold in our country in 1986 can be put at only a few hundred.

For those who do buy them it is a basic requirement that the machine work with the CP/M or compatible operating system. A number of unique configurations are made in order to expand the sales sphere. For example, use of a Winchester store greatly improves the speed parameters of the machine (for example, the MC 84/W, Raab 84/W and TZ-80/W), or they are offered as cheap intelligent terminals for local networks (like the MC 84/T, Multicenter terminals, Raab 84/T or VT-20/IV terminals), or they offer configurations developed for text processing (Kodex 2000, Mtext, Rosytext and Syster). So in the final analysis the manufacturers use some "spice" to try to make their systems palatable and thus improve the possibility of selling them.

It is not by chance that the majority of the new domestic models which appeared in this category in 1986 are among the special applications. We might list here, for example, the Alfadizk 87100 data recorder, the Econ-2000 book-keeping machine and the Gepard 8 telex computer.

Of the 8 bit professional machines with operating systems not compatible with CP/M only the machines of the VT-20 and Floppymat families are being manufactured. These are aimed almost exclusively at old customers on the domestic market where a significant quantity of software has been generated on such machines purchased earlier and they are replacing these or expanding

their systems. There is significant Soviet export of both types and this also justifies continuing manufacture.

The expiration of the category is also proven by the fact that only two new types in this category were shown at the spring Budapest International Fair in 1986--the Floppymat ISP and the Floppymat ISPD. By comparison seven new 16 bit and three new 32 bit models could be seen.

The circle of vendors of professional 8 bit machines constantly contracted in 1986; a number of firms stopped manufacture of the machines and began to sell off their inventory.

The price is the reason for everything. Although the price of the 8 bit professional machines dropped also it represented very serious problems that the price of the machines in this category is under the lower limit of profitability. Their prices cannot drop any more because technological progress has passed over them in the direction of the 16 and 32 bit machines. And since the price of these can decrease further as a result of development the category of 8 bit professional machines is doomed to die out.

One can see from the accompanying price table that the December 1986 prices of 8 bit and 16 bit machines overlap one another. So naturally the user will choose a 16 bit machine at the same price, or even cheaper.

Of the general purpose machines the Robotron 1715 is still marketable; many lease it, especially through the Saldo Enterprise.

The 16 Bit Machines: Machines Compatible With the IBM PC

Machines compatible with the IBM PC became virtually predominant in the 16 bit microcomputer category on the domestic market in 1986. Domestic trade in other types (PDP compatible and Z8000 based microcomputers) can be put at only a few dozen for the entire year. So we will discuss in detail only the situation of IBM PC compatible machines in this category.

Domestic trade in IBM PC compatible machines can be put at about 3,000 units in 1986. This represents a threefold increase compared to 1985 and it resulted in about tripling the inventory which existed at the end of 1985. But in value, in the present economic situation, this rate of growth borders on the miraculous. It shows that these machines are really indispensable in solving economic tasks; indeed, amidst the increasingly tense economic circumstances they have become active parts of the enterprise "survival" program.

In regard to power there were three models in domestic trade in 1986. Trade in the straight PC, which appeared in 1981 and has only floppy disk stores, hardly increased. Today they are bought primarily as terminals for local networks.

Domestic trade in the XT, introduced in 1983 and having a Winchester store, leaped last year and sales of this model make up the overwhelming part of 1986 trade in this category. This shows that the Winchester store is a practically

indispensable "partner" of a 16 bit machine in the interest of offering performance worthy of the 16 bits.

In 1986 the IBM PC/AT machines which appeared 2 years ago arrived in larger numbers for the first time, and their variety expanded also. This model offers about three times the power of the XT so it is used primarily in local networks.

The assortment was greatly restructured also. The variety of more powerful machines expanded greatly and the spectrum of local networks broadened.

The assortment of domestic models compatible with the IBM PC expanded greatly last year. The original IBM PC's are rather few in number. But during the year the assortment of compatible types broadened more and more, especially with the Far Eastern (Hongkong, Taiwan) machines. The first shipments reached our country in 1985. In many cases this meant delivery of semifinished products, so many Hungarian models (e.g., the MXT, MAT, Varyter XT, Varyter AT) are made with a very high Far Eastern content. The assortment of domestic IBM PC compatible machines was expanded during the year by five new types, including four corresponding to the AT, the most powerful version. The Microcontroll 87 of the Controll Small Cooperative, the Proper-16/MT of the SZKI-SCI-L [Computer Informatics Development Subsidiary of the Computer Technology Research Institute] and the Raab 86 of the New Ear Producer Cooperative in Győr correspond to the autonomous AT. The Eaststar-M of the Instrument Technology Small Cooperative is a network with a maximum of 16 work stations where every user feels that he has an AT computer as a result of the multi-processor parallel processing.

As can be seen from the table showing the market relationships for the category about 160 model configurations were offered on the domestic market at the end of the year using machines compatible with the IBM PC and taking various expansions into consideration the number of variations actually possible expands to many hundreds.

Removing overlap the number of firms selling IBM PC compatible machines and figuring in the table is about thirty. Half of these began to sell computers in 1986, and virtually all of them sell machines of Far Eastern origin. So in the course of last year the number of vendors of IBM PC compatible machines doubled.

The increase in the variety of models and in the number of vending firms resulted in a hard price war. Price was the chief player in this category during 1986. A serious over-supply developed so a person with more significant inventory, whether from manufacture or foreign acquisition, had to reduce his prices sharply in the interest of increasing turnover.

The threads go back to November 1985 when a large Novotrade shipment of Commodore PC 20's arrived. A radical price reduction was instituted--the sale price was 442,000 forints and the leasing fee was 668,000. Following this a price reduction wave spread to other domestic vendors like a chain reaction. Novotrade took the initiative again in March--the leasing fee dropped to 496,000 forints. Then, by the time of the Budapest International Fair, all

domestic vendors again carried out a significant price reduction. In September Videoton took the lead and reduced the price of the floppy disk VT-16 from 260,000 to 180,000 and of the version also handling a 10 megabyte Winchester store from 440,000 to 260,000. In October, at Orgtechnik '86, another four firms, including Novotrade and the Controll Small Cooperative, carried out new price reductions.

In November prices unexpectedly stagnated or even rose. We have graphically illustrated the year's price developments through the prices of the Controll Small Cooperative which reacts very sensitively to market conditions.

Since computer prices continue to fall on the world market the increase in domestic prices in November independent of this suggests expressly domestic causes.

Certainly a reason for the halt in price reductions could also be that as of 23 September 1986 the MNB [Hungarian National Bank] devalued the forint by almost 10 percent compared to convertible foreign exchange. This could cause a quarterly, almost "scheduled", omission in the price reductions, for the machines are obtained for hard currency. But the fact of the price increase suggests other causes--as a result of various rumors the volume of machines coming in through tourist travel fell strongly, which reduced supply, while demand for machines increased continuously, and even jumped from news of their becoming shortage items.

To sum up the events of the year in regard to prices, the domestic price level for machines compatible with the IBM PC fell by about 40 percent between January and December. This was caused primarily by the development of an oversupply and by the assertion of market mechanisms.

Despite the moderation of prices the price gap was extraordinarily and unjustifiably wide even at the end of the year. Our table reflecting the market relationships illustrates the situation at that time.

The 32 Bit Machines

Thus far there has been a development in two directions in our country in this performance category. The first domestic models based on the Motorola 68000 appeared in 1984, and since then the assortment of these types has not expanded. The sensation of 1986 was the appearance of the first true 32 bit microcomputers of domestic manufacture. These machines (the Mikrosztar-32 and the MVX-32) work with the VMS operating system. It increases their significance that they have prices and are sold. It must be noted that microcomputers of this power had not been made anywhere yet in a socialist country.

Many new initiatives characterized the buyer's market which developed in the area of microcomputers in 1986. For example, the leasing of computers spread; by the end of the year roughly 20 firms were involved with this. In accordance with the oversupply the lease conditions became more realistic; for example, the leasing multiplier exceeds two at only one firm and at the other extreme

it should be noted that a number of firms offer leasing contracts at a multiplier under 1.5.

Vendors try to dress up the computers with many services to make their models more attractive. The duration of the guarantee contract and inclusion in the sale price of general purpose software provided with the computer and training in using it mean the most to customers.

Peripherals

The oversupply in the area of matrix microprinters, which appeared in 1985, increased. Prices fell further accordingly. We could observe a 10-40 percent price drop compared to 1985, which means a 20-50 percent drop compared to 1984. For example, the price of the popular Epson FX-105 printer for the IBM PC fell from 150,000-180,000 forints at the beginning of the year to 105,000 by the end of the year.

The popularity of daisy wheel printers increased but this category continues to be a shortage item. The first laser microprinters in the country also appeared during the year. The number of these will probably increase quickly in 1987 for in price and performance they suit the 16 bit microcomputers well.

Winchester stores offered as independent peripherals were virtually a new item in 1986. A number of firms announced replacement of existing Winchester stores with larger capacity ones, building in a Winchester store or delivering one in a separate housing. This applies almost exclusively to machines compatible with the IBM PC.

Continuous magnetic tape stores (streamers) appeared in tangible quantities on the domestic market only in 1986. A considerable offering developed by the end of 1986 with 13 firms offering such peripherals. Trade, however, was not considerable so prices rather failed to develop. Probably the volume sold will increase greatly in 1987 as they are beginning to generate on the professional microcomputers larger and more valuable data files which cannot do without regular saving. In the last months of the year half a dozen firms, one day after another, began to offer hardware-software combinations to save data to video tape. But the number of actual purchases was still relatively small.

To sum up we can say that trends very favorable in the eyes of users developed on the microcomputer market in 1986--the assortment of modern, highly reliable microcomputers expanded significantly, the number of firms trading in microcomputers increased strongly, prices moderated radically as a result of the oversupply thus produced and the services provided with the machines expanded significantly.

Seeing these effects of the market mechanisms, so advantageous for the user masses, we hope that 1987 will close with similar successes.

Development In 1986 of the Price of the MC 86 (IBM PC/XT Compatible) Computer of the Controll Small Cooperative (in thousands of forints)

1 Jan, 790; 20 Mar, 577; 1 Jul, 499; 3 Oct, 420; 10 Nov, 460

Domestic Professional Microcomputers Which Appeared in 1986

Model	Manufacturing firm	Micro-processor	Bits	Memory (K bytes)	Operating system and notes	Programming Language and notes
Alfadiszk 87 100	Datakoord	Z80	8	64	data recorder	
CS 16 PC XT	Csepel Electronic	Intel 8088	16	256	MS-DOS	IBM PC/XT compat.
Eaststar-M	Instrument Technology	Intel 80286	16	1024-9216	MS-DOS	IBM PC/AT compat.
Econ-2000 Floppymat ISP	Elepszer Vilati	Z80 F 8	8 8	64 60/4	Special Disk	Bookkeeping A, PLF8
Floppymat ISPD	Vilati	F 8	8	60/4	Disk	A, PLF8
Gepard-8	Triton small coop	Z80	8	64	Telex	
Micro-controll 87	Controll small coop	Intel 80286	16	512-3087	MS-DOS	IBM PC/AT compat.
Mikrodat	Mikrodat	Rockwell 6502	8	16-64	Apple-DOS	Apple II compat.
Mikrosztar 1123	SZAMALK	K1801VM2	16	512-4096	RSX-11M (OS-RV/E)	PDP 11/23 compat.
Mikrosztar 32	SZAMALK		32	4096-16384	VMS	B, C, F, P, PL/I
Multi-center-Turbo	Instrument Technology	Z80	8	64	MSYS, MIREAL, MINET	A, B, C, F, P, PL/I
MVX-32	Instrument Technology		32	1024-4096	VMS	B, C, P, C language
Proper-16/MT	SZKI-SCI-L	Intel 80286	16	512-2048	MS-DOS	IBM PC/AT compat.
Raab 86	New Ear TSZ Gyor	Intel 80286	16	640	IBM PC/AT compat.	
TAP-34M	Telephone Factory	Z80	8	64	CP/M	A, B, C, F, P
TPA-11/130	MTA KFKI	K1801VM2	16	512-4096	RSX-11M (OS-RV/E)	LSI 11/23 Plus comp.

Notes: A=Assembler, B=BASIC, C=COBOL, F=FORTRAN, P=Pascal.

Domestic Market for IBM PC Compatible Computers (December 1986)

Characteristic	IBM PC	IBM PC/XT monochrom.	IBM PC/XT color	IBM PC/AT	
and compatibles.....				
Number of models	29	49	38	50	
Number of manufacturers and vendors	20	24	24	28	
Difference between minimum and maximum price (in thousands of forints)	Originals	--	550	500	750
	Clones	310	630	690	1490

Characteristic Microcomputer Prices

Computer	Notes	Manufac/ Vendor	Price in thousands of forints						
			Dec 83	Dec 84	Jun 85	Dec 85	Mar 86	Jun 86	Dec 86
Professional 8 bit machines:									
Comput 80	1	Comproject	420	350	350	350	350
HT 680X		HTSZ	..	250	150	150	150	150	150
MC 84/A	2	Controll	--	--	340	289	289	289	210
Proper-8	3	SZKI-SCI-L	..	677	384	250	250	250	250
IBM PC compatible machines (256 K plus monochrome screen):									
MC 86/A	4	Controll	--	--	--	--	319	299	210
MXT	5	Instrument T.	--	--	--	420	420	190	190
Proper-16/A		SZKI-SCI-L	800	..	650	489	--	--	--
Proper-16/m	6	SZKI-SCI-L	--	--	--	266	266	266	266
VT-16	7	Videoton	--	--	--	--	260	260	180
IBM PC/XT compatible machines (256 K plus monochrome screen):									
700-HGE-Turbo	8	Econorg	--	--	--	--	..	650	520
IBM PC XT	9	Ramovill	--	1000	690
MC 86/27	10	Controll	--	--	--	780	780	577	460
MXT	10	Instrument T.	--	--	..	695	695	395	395
PC-20*	9	Novotrade	--	--	--	442	442	442	350
PC-20*	11	Novotrade	--	--	--	668	496	496	432
Proper-16	12	SZKI-SCI-L	--	..	895	742	742	439	439
W/W1									
Varyter XT	8	MTA SZTAKI Cosy	--	--	--	672	379
VT-16	9	Videoton	--	--	--	--	440	440	260
IBM PC/AT compatible machines (640 K plus monochrome screen):									
MAT	10	Instrument T.	--	--	--	--	..	595	530
MC 87	10	Controll	--	--	--	--	--	700	650
Szamszov computer	10	Szamszov	--	--	--	--	..	900	750

Notes for price table:

1. 2 x 5.25 floppy
2. 1 megabyte floppy
3. 64 K + 2 floppy
4. 1 x 360 K floppy
5. 2 x 360 K floppy
6. 2 x 720 K floppy
7. 2 x 1 megabyte floppy
8. 20 megabyte Winchester
9. 10 megabyte Winchester
10. 27 megabyte Winchester
11. 10 megabyte Winchester, leasing
12. 10/27 megabyte Winchester

* indicates a Commodore machine.

"--" means model not yet or no longer manufactured.

".." means data not available.

Prices are for orientation only; services (e.g., guarantee) may differ.

Socialist Made Micro and Minicomputers Which Appeared in 1986, by Country

Country	Model	Manufact. firm	Micro-proc.	Bits	RAM/ROM kilobytes	Operating system	Program languages
Bulgaria	Fadata	VMEI, Sofia	Motorola 68000	32	1024/64	FANIX (UNIX)	A, B, F, P, C lang.
	Intelat	ISSU, Sofia	Intel 80286	16	640	MS-DOS	IBM PC/AT compat.
	Interlab 1600	BTA, Sofia	Motorola 68000	32	2048	VERSODOS	CAMAC
	Interlab 1610	BTA, Sofia	Motorola 68000	32	2048	VERSODOS	Graphics
	Interlab 1620	BTA, Sofia	Motorola 68000	32	2048	VERSODOS	Graphics
	IZOT 1040 C	IZOT, Sofia	..	16	1024	Graphics terminal	For 16-32 bit comp.
	IZOT 1042 C	IZOT, Sofia	Z80	8	64	Chess computer	
	IZOT 1052 C	IZOT, Sofia	SZM 601 (M6800)	8	64	Hotel	FAL-2
	IZOT 1055 C	IZOT, Sofia	..	32	4096	VMS	11/730 compat.
	MIC 16 Turbo	Robotics Inst.	Intel 8088	16	256	Radiator-form	IBM PC/XT compat.
	MIC 16B	Robotics Inst.	Intel 8088	16	256	Desk	IBM PC/XT compat.
	MIC 16E	Robotics Inst.	Intel 8088	16	256	Europa card	IBM PC/XT compat.
	MIC 16N	Robotics Inst.	Intel 8088	16	256	New design	IBM PC/XT compat.
	Partner	SPS, Sofia	Z80	8	64	Chess computer	
	Pravec 8A	Pravec Computer	Z80	8	64-1024	CP/M comp.	Apple II compat.
	Pravec 16I	Pravec Computer	Intel 8088	16	256	Portable	IBM PC compat.

Socialist Made Micro and Minicomputers Which Appeared in 1986, continued.

Country	Model	Manufact. firm	Micro-proc.	Bits	RAM/ROM kilobytes	Operating system	Program languages
Bulgaria	Pravec 16N	Pravec Computer	Intel 8088	16	256	MS-DOS	IBM PC
	Super 11	IZOT, Stara Zag.	Intel 8088	16	512	PC-DOS	IBM PC compat.
Czechos.	Consul 2715	Zbrojovka, Brno	MHB 8080	8	64	BAL (CP/M comp.)	BAL, RPG
	M 16-22	ZVT, Namestovo	AM 2900	16	1024	RSX-11M	PDP 11/44 compat.
	PC 88	TESLA, Postyen	Intel 8088	16	256	PC DOS 2.0	IBM PC compat.
	PP 01.16	VUVT, Zilina	K1810VM88 (8088)	16	64	PP DOS (MS-DOS)	IBM PC compat.
	SMEP PP 06B	TESLA, Banska Bystrica	Intel 8088	16	640	PP DOS (MS-DOS)	IBM PC/XT compat.
Poland	ELWRO 800 Junior	ELWRO, Wroclaw	U 880 (Z80)	8	64	CP/M + Monitor	Spectrum compat.
	FRA-SZM	16	256	PDP 11/23 compat.	B, C, F
	Mazovia 1016	..	K1810VM86 (8088)	16	256-640	MS-DOS	IBM PC/XT compat.
	Mera 660	16	256	PDP 11/23 compat.	B, C, F
GDR	A 5222	Robotron	U 830	16	64	RSX-11M	B, C, F
	K 8915	Robotron RVB	U 880 (Z80)	8	64	CP/M	A, B, C, F
	K 8918	Robotron	Intel 8086	16	64-640	MS-DOS	Terminal
	KC 85/1	Robotron, Dresden	U 880 (Z80)	8	16-64	Monitor	A, B
Romania	Felix PC	ICE-Felix	Intel 8088	16	1024	MS-DOS	IBM PC compat.
	HC-85	ICE-Felix	U 880 (Z80)	8	48	Monitor	Spectrum compat.
	I-106	ICE-Felix	AM 2900	8	64	PDP 11/44 compat.	A, B, C, P
	Junior	Feper	U 880	8	64	JR-DOS (CP/M)	A, B, C, F

Socialist Made Micro and Minicomputers Which Appeared in 1986, continued.

Country	Model	Manufact. firm	Micro-proc.	Bits	RAM/ROM kilobytes	Operating system	Program languages
Soviet Union	ARM-2	Elektronmas, Kiev	K1801VM2	16	2048	OS-RV	PDP 11/44 compat.
	Irisa	..	Intel 8080	8	16-64	Monitor, school	A, B
	Iskra 502	Ryazan computer	K1810VM86 (8086)	16	64-640	MS-DOS	IBM PC compat.
	Iskra 1030	Ryazan computer	K1810VM86 (8086)	16	64-640	MS-DOS	IBM PC compat.
	Iskra 1130	Ryazan computer	K1810VM86 (8086)	16	64-640	MS-DOS	IBM PC compat.
	SZM 1634.17	Elektronmas, Kiev	K1801VM2	16	256	Process control	PDP-11 compat.
	SZM 1700	Sigma, Riga	..	16	256	PDP-11 compat.	B, C, F
	SZM 1840	Minsk computer	K1810VM88 (8088)	16	256	MS-DOS	IBM PC compat.

Notes: SZM is the Hungarian abbreviation for CEMA uniform small computer system. A=Assembler, B=BASIC, C=COBOL, F=FORTRAN, P=Pascal.

8984
CSO:2502/57

HUNGARY: MODEL COMPUTER INTEGRATED MANUFACTURING SYSTEM

Budapest UJ IMPULZUS in Hungarian No 8, 18 Apr 87 pp 8-9

[Article by Janos Kis: "A CIM Model System; The Possibilities Outlined"]

[Text] It was 20 years ago that they began to deal seriously in the developed capitalist countries with the development of CAD/CAM manufacturing lines. The goal, to operate "mental factories" with minimal human strength, has already been achieved in some areas. They do not gladly transfer this technology to other countries--in the interest of preserving their own industrial superiority. So we must rely only on ourselves, practically from the first steps. It was again necessary to travel to the end the road leading to the goal, one not free of errors. This delay--they began to deal seriously with this theme in our country only in 1970--was also good in that it permitted the crystallization of those standards which have to be considered in our own developments if we want to buy and sell on the world market.

About 10 years ago the BME [Budapest Technical University], the MTA SZTAKI [Computer Technology and Automation Research Institute of the Hungarian Academy of Sciences] and the GTI [Machine Industry Technological Institute] set up their first experimental CAD/CAM system at the Machine Manufacturing Technology Faculty of the Mechanical Engineering School of the BME. At that time a CAD computer center was developed with a SZTAKI GD-80 graphic display and Videoton terminals based on a TPA 11/40 central computer. This was followed by a CAM cell line to manufacture rotating and box-type parts and by an automatic measurement cell. This system was already suitable to serve as a base for instruction and developmental work.

The SZIM [Machine Tool Industry Works], jointly with the VILATI [Electric Automation Institute], developed a center to process complexly formed surfaces. Because of the embargo this product is of key importance for socialist industry. The VILATI made the controls, the SZIM made the machine tool and the Machine Manufacturing Technology Faculty of the BME made the programming system.

As these projects were going forward the SZTAKI also developed a new CAD system, so a number of program packages have appeared on the domestic market. When all this was working properly they started the G-6 program which had an educational development subprogram which is unique in its category. The

program for the scientific park to be established at the BME was linked to it. A rational application of these resources opens the possibility for developing a model system for computer aided integrated design, manufacture and organization, which has the new abbreviation CIM (computer integrated manufacturing).

Fortunately the experts recognized in time that such a large-scale system might serve more than educational purposes. If reliable data transmission lines can be established (they will probably build a glass fiber cable connection between the Academy network of the SZTAKI and the CIM system of the BME) then the several research institutes could use the artificial intelligence integrated into this system just like the industrial enterprises.

The practical possibilities for building industrial CIM systems have been outlined already, so the finances and intentions necessary to acquire machines are approaching. But however great the capacity of a system it can be used only if the constituent elements are capable of working with one another. To do this we must change earlier investment practice whereby every enterprise gets the type of equipment it can from where it can most cheaply and most simply. Naturally these devices and their software are compatible with one another most rarely. This situation can be changed only continuously by standardizing the interface surfaces of existing devices and by coordinating new acquisitions.

Realization of CIM will also create a foundation for cultivating another peak technology. Modern computer technology equipment requires ultraprecise parts--worked with micron tolerance. These parts are vitally important here for the parts turning at great speed--floppys, Winchesters and even turbine blades--must be made with a precision of about one micron. This is impossible with traditional technologies. High precision machine tools, suitable tools and precise controls for them are indispensable, not even to speak of measurement devices. The domestic development of these also puts a great task on the experts.

Forming the awareness of experts must precede the introduction of modern technology. This work tolerates no sort of organizational anarchy or technological laxness. The BME system will prepare experts for this in real situations and on real tasks.

Key to accompanying figure:

1. Machine Structure Institute
2. University network
3. Electrical Engineering School
4. Instructional terminals
5. Machine Manufacturing Technology Faculty
CAD/CAM system
6. Faculty connections
7. CAD laboratory
8. Mechanical Technology
and Material Structure
Institute CAD laboratory
9. Industrial Economics
Faculty CAE laboratory
10. Textile Technology and Light Industry Faculty
CAD/CAM laboratory

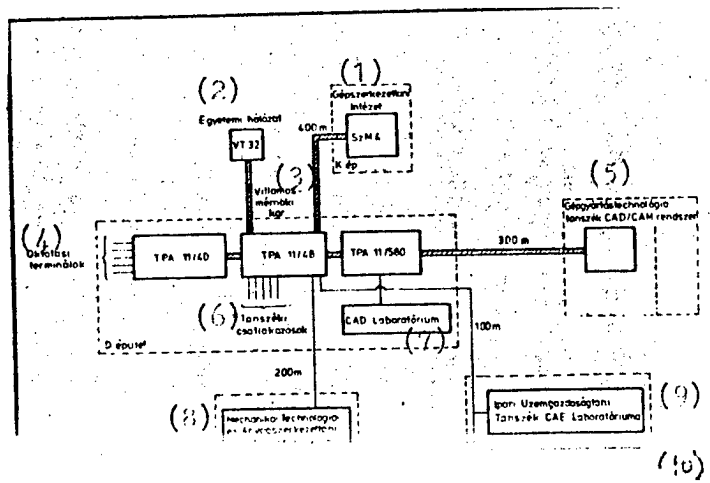

8984
 CSO: 2502/60

PROGRESS OF AUTOMATION IN CZECHOSLOVAKIA

Warsaw PRZEGLAD TECHNICZNY in Polish No 48-49, 30 Nov-7 Dec 86 pp 37, 39

[Article by Engineer Bedrich Cudlik: "Automation in Czechoslovakia"]

[Text] The problem of integrated production of single and small-quantity units began to be resolved only in the last several years by applying the achievements of modern technology and science. This is linked above all with the use of electronics and computer techniques, which permit elastic automation of individual workstations as well as technological systems.

The first highly automated, integrated processing systems were developed, expanded and implemented simultaneously by the Czechoslovak machinery industry. Machines, equipment and automated production systems should operate at least in a three-shift, 5-day workweek system. If we introduce the next generation of machines and equipment, which will be significantly more efficient, more highly automated but more expensive, then continuous operation will be truly essential. Today we already have problems employing workers on the second and especially third shifts. For objective reasons, it will be even worse in the future. In association with this we have adopted the following principle: maximum interchangeability of machinery with minimum shifting of workers.

Elastic Production Systems

Digital equipment and computer techniques are the resources for automating all kinds of production. The extent to which these resources are used depends on production volume, required elasticity, economic capabilities of investors and equipment availability.

Elastic production systems are created by combining digitally controlled machine tools and machining centers with manipulators, storage bins, an interopertional system to transport machined components and tools, and a computer system that controls, evaluates and optimizes production.

An elastic production system is equipped with a materials-preparation station in combination with palletization of machined components and preparation of tools which guarantee that initial provisions will be provided during the

first work shift for the entire system for continuous three-shift operation with minimum service during the second and third shifts.

The Czechoslovak engineering industry already has much experience in designing, building and operating integrated production systems. It is projected that an increase in first shift output of 160-400 percent will increase annual production capacity of a department or line 520-1400 percent, and labor productivity 300-590 percent. Some other advantages are:

--Labor force savings, especially in plants lacking sufficient casting preparation workers, and specialists to operate milling machines, lathes and borers;

--Much more accurate planning at the department level and more flexible reaction to shorten production time;

--Improved quality, fewer defects;

--Improved work culture and working conditions;

--Fewer auxiliary workers needed to handle materials, semi-finished products, tools and machined components.

Elastic production systems have been installed at the Tovarny Strojirenske Techniky (TST) plant in Prague.

The elastic production system for the complex machining of non-rotating cast-iron parts measuring 400 x 400 x 400 mm used at the machine tool factory in Olomouc is an example of high level technology. The system consists of seven engineering stations based on the MC FHD 63-PVS machining center with a spindled horizontal axis. Each workstation is equipped with a manipulator with a container having 144 locations for tools. A station also includes a rotating pallet loader, rotating cleaning systems, a slide plate with a NS 750 computer and control equipment, which together with the ADT microcomputer from the Cakowice Plants for Industrial Automation permit joint computer control of four workstations.

A CNC computer controlled piler assures interoperational manipulation of machined components mounted on a pallet between individual workstations at the material preparation shop, cleaning equipment and the storerooms with shelves.

The interoperation manipulation of tools between the individual workstation storage bins and the two storage bins of the auxiliary tools section is accomplished by the computer controlled transporter for tools.

The entire system is controlled by a set of ADT 4500 microcomputer mounted along the control line (direct digital control, controlled transport of tools and machined components, planning) and on the technological line (computer controlled workstations and tool manipulators).

The elastic production system at the TST KOSOVIT plants in Sezimovo Usti is also a very modern system designed for complex machining of circular

components made from bars having diameters of 20-80 mm. The system consists of five engineering workstations based on a UCSY 50/80 multifunctional machining center with two lathes.

Each center machines from both sides by turning and cutting threads; spot drilling and boring components that are eccentric, parallel and perpendicular to the axis; milling frontal and flank surfaces; machining grooves parallel or off-center to component axes; and setting bends in cylinders. The tools are changed automatically in the tool containers. Rods are placed in the automatic feeding stacker.

The entire system is controlled by the ADT 4500 minicomputer on the production process control line (direct computer control, transport system control, planning) and the NS 561 system on the technological process line are computer controlled.

The TP800 engineering workstation in operation at the Celakovice TST TOS plants is designed to machine box-type cast-iron components measuring 800 x 800 x 800 mm. They consist of two MSFHD 80-PVS machining centers with a spindled horizontal axis produced by TST TOS Kurim. the Celakowice engineering workstation is equipped with a manipulator and a container having 144 places for tools.

Integrated Automation

A portable computer pallet assures interoperational manipulation of components mounted on the engineering pallet between the two workstations, the material preparation station with manipulation tables and measuring equipment, the cleaning equipment and the single-axis storage place.

During the last 5-year period research by the Institute for Experimental Industrial Technology and Economy in Prague on integrated automation of machine industry plants was realized successfully. The results of this research have been applied, for example, by TST TOS Hostivar.

The plant's main production is concentrated in 13 production units, starting with the storerooms and ending on the assembly line, and is verified as a joint system with external division into automation of production and control processes.

During 1979 and 1985 four integrated lines for machining components were palced into operation that include automatic interoperational transport and storage as well as automated systems to directly control the production system in real time using SMEp series computers (System of small electronic computers). Next, the problem of automatically changing production was resolved. A system to remove chips and the first part of an automated interdepartment transport system using battery operated trucks were added. At the same time an automated system to control production operatively was built, in which the major part consists of the operational system for production planning together with short-term planning and direct control of the production process as well as an automated system for recording storeroom supplies. The entire control system is connected to the internal enterprise

management system that verifies economic results in conjunction with the progressive method of rewarding workers at the brigade level.

A Workstation Without Service

Digitally controlled machine tools that do not require service, which are now the ultimate for automating production of single or small-quantity units, play a very important part in the development of integrated automation.

The current world trend confirms this direction, which is a reaction to the need to increase productivity while maintaining elasticity of production.

Using machines that do not require service allows preparatory work to be concentrated during the morning shift, minimizes service and reduces the need for supervision during the afternoon and evening shifts.

What Is Our Goal?

Accelerating the development of integrated automation in Czechoslovakia's machine industry will guarantee participation in the realization of the integrated program for scientific and technical progress in the CEMA countries to the year 2000. One of its five priorities encompasses 13 problems on integrated automation, including the development of elastic production systems.

New technological solutions for elastic automated systems consisting of machine tools that do not require service and an appropriate interoperational transportation system that could be used for single and small-quantity production are being sought based on the results achieved during the development and production of digitally controlled machine tools, machining centers, industrial robots, robotized complexes and computer techniques.

The stipulations of the skeleton agreement concerning cooperation among CEMA-country organs and organizations became obligatory in Czechoslovakia in 1985, in accordance with the program of cooperation regarding the introduction into production, specialization and cooperation in the production of elastic production systems.

Automation of production processes is dictated by the needs of the moment and not, as some believe, by the distant future. Czechoslovakia not only is devoting its attention to the development of automation in industry, but it also is creating the essential conditions for it.

11899

CSO:2602/19

HUNGARY: MICROELECTRONICS ENTERPRISE REMAINS ACTIVE DESPITE FIRE

Budapest MAGYAR NEMZET in Hungarian 13 May 87 p 5

[Article by Laszlo Gergely: "Microelectronic Scales: One Year After The Fire"]

[Text] I scanned the 1983 file copies of MAGYAR NEMZET so that I recall some statements by the deputy minister and commissioner of industry in those days. Here it is: "One of the most urgent tasks is to create a demand for the products of the Microelectronics Enterprise [MEV] ..." "The manufacture and use of equipment-oriented circuits is definitely more economical in Hungary than in developed capitalist nations, simply because the cost of cerebral work in Hungary is significantly lower than there, unfortunately ... Our chances to increase exports by selling excellent quality microelectronic component parts built into finished products is very good. By delaying action we may provide too great an advantage for our foreign competitors--a competitive advantage we could not catch up with. And most certainly, this is not what we want ..."

The review continues at a later date: May 1986, relative to a new statement by the deputy secretary: "Fire was discovered in Pavillion "T" at 0604 hours. Extinguishing operations began eight minutes later. At the fire's point of origin there are some rather important pieces of equipment that produce component parts. This is where the most important operations take place regarding microelectronic component parts, notably the chips." Another year later, once again there is something to be clipped from the papers. In mid-April 1987 a document that provides for the establishment of a new Hungarian-Soviet joint enterprise was signed in Budapest. One of the founding firms is MEV.

Debate About The Non-Existent

The projection that reminded us of a fatal shortfall was followed--fatalistically--by the chronicle of a large-loss fire. After all this, may we consider the joint enterprise as a sign of life? Yes, according to MEV president dr Bela Balogh. He condensed into a single sentence the in-house command of the past twelve months: "Let's keep the trouble inside, our partners should sense our fire-related concerns as little as possible!" The valves and the locks were shut tight: the public virtually forgot about the enterprise on Foti street. Not so the partners who delivered the necessary microelectronic

component parts to the Hungarian firm. They mastered the situation with joint effort--the users indeed did not suffer damage. So much so that now, at the beginning of May, VILAGGAZDASAG carried a quarter-page advertisement offering equipment-oriented circuits ...

"We had a variety of options following last year's fire damage," the president explains. "The work of more than 200 persons became seemingly unnecessary. Considering the enterprise's financial situation, layoffs would have appeared as the logical solution. But only 'would have'! We did not follow that path, simply because we were intent on preserving the essence of MEV accomplishments, even at the cost of the greatest economic sacrifice. True, with the passage of months, the satisfaction of this commitment became increasingly difficult, and this was so not solely because of lack of financial resources. Even faith and confidence went up into flames last year ..."

This is understandable, and so one can also understand that the president and most of his associates played the role of a kind of spiritual counsellor. Their reasoning equally applied to themselves and to workers who had lost their faith: the enterprise will be able to recover from its troubles, because after all, MEV has what it takes. They have and continue to have a technically and technologically well-founded concept, one that is accepted and approved by all domestic professional forums. The central authorities continue to debate about financial resources even today. Note: something that does not exist is not debatable ...

"I agree with this only in part," Balogh argues. "Irrespective of our fire incident, nowhere in the world does the state remove itself from the establishment, functioning and perspective of its microelectronic industry base. This is so because no nation views its semiconductor industry as just another simple part of the economy."

From One Day To Another

By the end of the previous 5-year plan period, the enterprise on Foti street experienced a rather difficult economic situation. To change this situation, in 1986 the enterprise took a number of autonomous actions. It did so in a period when an investment process worth several milliard [billion] forints in essence could have come to an end, an investment process together with an increasing ratio of developmental and operating fund credits, just to add an abundance of burden to the already existing financial burdens. Although the governmental program concerned with microelectronics encourages the development of semiconductor manufacturing at a rate faster than the industrial average, thus making that industry a lead industry, MEV's financial situation forced the enterprise to adopt a management style that was reduced to a short term outlook, one that lives and plans on a day-to-day basis.

"If at least our starting position could be similar to theirs," the president notes. "I would say the same if we would not have had that fire last year, except that the emphasis would be on something else. We would not stress the issue of whether there should or should not be a new plant to replace the old one. Because today, unfortunately, this is the way the issue is defined by many. According to the new agreement, there will be established a microelectronic joint enterprise founded on the production and cerebral capacity of two Soviet enterprises, and of the Telecommunications Technology Association and

MEV. Preparatory negotiations at the professional level began well over a year ago, and even though the fire and its consequences caused difficulty, none of our partners questioned the justification of the joint enterprise, none of them wrote off our enterprise. Our work relationship with firms having a similar profile in the rest of the socialist countries is similar at the technological, technical and product application levels. The times when we kept meeting for the sake of semblance only are gone. They would not even talk to us if we were unable to pay for their products with products of equal value."

The Stakes Are Higher

Through its international relations and upon the encouragement of its Western partners MEV became convinced that it must concentrate all its energies to shore up. Although this sounds like a phrase, the explanation dispelled our doubts. In the days and weeks following the fire damage, they began a painstaking analysis of what, how and when could be restored by using their own strength, without outside help. As it turned out, in spite of substantial damage, the projected "intramural" accomplishments were not insignificant. It is characteristic of the enterprise's inventiveness, that even under the present economic conditions they found a way to reconstruct their diode manufacturing process. (Using their own resources they developed the world's most productive diode production line.)

The most recent accomplishment: they found a solution for the manufacture of high capacity microelectronic component parts. It is an odd, schizophrenic situation: MEV on the one hand consistently seeks improved methods of supplying domestic component parts, on the other hand, on a daily basis it (Hungary's sole microelectronic industry base) is confronted with economic infeasibility. True: the enterprise cannot resolve all of its concerns by using its own strength. But they resorted to seek state budgetary assistance only when they really did not have the money. The president showed us the 1986 balance sheet so that we can see for ourselves that indeed, the state budget need not rush to MEV's assistance by dispensing alms. It was precisely in the critical year of 1986 that the Ujpest-based enterprise contributed to the state coffers four times more money.

"We are not living off the people's economy, and if the enterprise were functional, if it had minimum resources, it could immediately begin to restore its battery manufacturing processes," according to Balogh. "It is obvious that the new plant would not be built here in this overcrowded environment. Not because of its hazards--after all our technology is more friendly to the environment than most domestic branches of industry. We have a plan for each move we must make. And this is not merely an issue of having to reconstruct a microelectronic battery manufacturing plant. By the time the new battery manufacturing plant is finished, the attendant technological environment must also be five years ahead of the anticipated state of the art, at a minimum. I note here that this too would serve to ascertain that compared to our competitors in the East and the West, that certain technology gap in our field would not increase."

The fire of a year ago damaged more than the equipment. That was the time when MEV was about to begin work at full intellectual and technical capacity. At last it was about to demonstrate the place, role and perspective of

domestic semiconductor manufacturing within the domestic industry. Indeed. Just how is that place, role and perspective? According to its financial balance sheet, MEV is a profitable enterprise even after, and in spite of the fire.

Except for the fact that the stakes are higher than that.

12995

CSO: 2502/63

DEVELOPMENT OF ELECTRONICS IN ROMANIA

Bucharest REVISTA ECONOMICA in Romanian No 52, 26 Dec 86 pp 10-12

[Article by Octavian Juncu, director, Research and Technological Engineering Institute for Electronics: "Romanian Electronics: World-Class Innovation and Creativity"]

[Text] The directives of the 13th party Congress regarding the economic and social development of Romania under the 1986-1990 5-year plan and long-term trends to the year 2000 devote much space to scientific research, to which they assign the task of "raising the technical and quality level of all material production through extensive promotion of automation and cybernetic applications in production, along with introduction of the latest achievements of science and technology, so as thereby to develop a modern highly productive and efficient economy."

The trends for the electronics industry, a critical sector experiencing spectacular growth with numerous economic and social implications, fit into this context, which forms an indissoluble part of the revolutionary scientific thinking of the secretary general of our party, Comrade Nicolae Ceausescu.

Professional electronics, as a principal generator of technical progress, which makes a decisive contribution to increase in labor productivity accompanied by reduction of physical labor, improvement in product quality, radical innovation of many technologies, improvement in production management and organization methods, and management of material resources with maximum efficiency, together with automation and computer technology, utilizes human labor and intelligence to the highest degree. Products of very high value are made in these sectors, products which incorporate in themselves a large volume of know-how plus minimal consumption of materials and energy.

Hardly an area exists today that has not been penetrated by electronics and in which electronics has not brought about appreciable increase in efficiency. The performance of a product made today is the higher, the greater the extent to which it includes electronics applications. And not just products, but technologies as well are increasingly incorporating electronics applications, and their performance improves in proportion to the extent that these applications are incorporated in the technologies. The incorporation of electronic equipment in technological plant and equipment used in widely varying sectors of the economy imparts a significant value to them as a result

of increase in efficiency, diversification of functions, growth of the output of equipment, and indirectly better utilization of the human factor.

The fact that Romanian electronics is today an active reality in the technical and scientific sphere in Romania is a result of the policy of the Romanian Communist Party and a success of socialism in Romania. We have a highly developed electronics industry today. A wide range of electronic components is made in Romania, from passive components to integrated circuits, including high-density circuits, kinescope tubes, ferrites, and quartz devices. A great variety of electronic equipment is manufactured, from radio and television sets and audio equipment to radio relays and broadcasting stations, complex measurement and control apparatus for laboratories and industrial use, radio communication and telecommunication installations, including reception installations for satellite communications, medical electronic apparatus, and automation installations in the area of data processing equipment. The progress made in this critical sector of the national economy is shown even more clearly by the fact that over the 1950-1965 period the electronics industry was active only in the area of items representing consumer goods and of parts used in building radio and television sets. The majority of the electronic components needed for manufacturing these items were imported.

Electronic measuring apparatus, professional radio broadcasting equipment, and electronic computers were imported. There were as yet no enterprises specializing in professional electronics, and no systematic research was conducted to support this sector. Development of the other sectors of industry and the economy required that suitable progress be made by electronics, whose structure had to be adapted to the need for all-round economic development of the country. At the same time, the experience gradually accumulated in research and industry created the conditions needed for inaugurating professional electronics.

The programs set up during the first years of the 1966-1970 5-year plan represented an important stage of progress for the Romanian electronics industry. Original research was initiated in the area of professional electronic apparatus. A powerful and well organized base was accordingly created for research in this area. Established in 1966, the Institute of Electronic Research had the mission of developing new products (which had not previously been made in Romania), but it was necessary in particular to create a new industry, with the appropriate enterprises and specialists, with a style and personality of its own, an industry which by its results was to meet the needs of a national economy undergoing rapid and complex development.

One of the important accomplishments of the Ceausescu era has been the establishment of a large and strong family of specialized enterprises which have earned well-deserved fame for themselves within a short time (the Measuring and Industrial Equipment Enterprise and the Industrial Electronics Enterprise in Bucharest, Tehnoton in Jassy, the Cluj-Napoca Industrial Automation Equipment Enterprise, and the Urziceni Ferrite Products Enterprise). These enterprises are grouped around the Scientific Research and Technological Engineering Institute for Electronics. Each of these enterprises, and the production departments of other units, use chiefly technologies and products designed by Romanian research, on the basis of programs for scientific research and extension of technical progress set up under the guidance of Comrade Elena Ceausescu, first deputy prime minister and

chairwoman of the National Council of Science and Education. To characterize the evolution of Romanian research over these years in the area of electronics, it should be pointed out that for several years now the products that have been turned out are almost all the result of Romanian research and development.

A constant effort is made to reduce imports by utilizing the research that has been conducted. The contribution made by research groups which have developed high-performance Romanian-made products that have reduced or eliminated imports of measuring and control equipment, systems for radio control of technological processes, etc, has satisfied virtually all the needs of the national economy. At the same time, research makes an indirect contribution to exports in the form of components or installations supplied to other enterprises for products intended for foreign customers (ferrites for coil-loaded cables, electromagnets for electric motors, automation and control systems for diesel locomotives, measurement and control apparatus for industrial processes, etc).

The chief aim of research in the area of electronics is development of products needed by specialized enterprises subordinate to centrals and the supervising ministry for manufacture of unique equipment or small series of equipment needed in completion of national high-priority projects, such as the Danube-Black Sea Canal, the Bucharest Metro, nuclear power plants, and the mining program, or in remote control and automation of producing oil wells, ground stations for reception of weather data transmitted by satellites, etc.

In the area of radio communications, the development of a wide variety of especially complex systems has been initiated to solve urgent problems of the economy. Customers are now offered not just different items of equipment but complete solutions including conception, research, design, production, installation, and activation of entire equipment complexes meeting the needs of specific practical applications. A series of complete networks has been developed in this direction, among them a centralized radio control system for oil fields in production (see sidebar 2), a system for dispatcher control of traffic on the Danube-Black Sea Canal, and radio communication equipment and networks for the Bucharest Metro. The latter items were designed with professional equipment incorporating modern components, including microprocessors, and all the measures were taken to ensure the quality and reliability required for traffic safety.

Equipment has been developed for maritime radio communications, and production of the equipment has started in recent years (for example, at Tehnoton in Jassy). The Romanian fleet is now outfitted with this equipment, which uses Romanian-made components almost exclusively and which meets the requirements of the Romanian Ship Register and of other ship registers, so that it may be incorporated in ships built for export.

The design and development of microwave equipment for radio communications by satellite put the achievements of the Romanian electronics industry on a par with the accomplishments of countries throughout the world which are leaders in this regard.

Measurement and control apparatus for electric and non-electric quantities, which plays an especially important part as a factor in technical progress,

has also represented a highly developed area of Romanian research. The contribution of electronic measurement technology, which has recently been associated with computer technology, is decisively important in areas such as efficient design of machine components and construction elements, machining of mass-produced precision parts, control of complex technological processes in chemistry and power engineering, geophysical research and extraction of hydrocarbons, process and operating control of products and installations, and so forth (see sidebar 1).

The basic objective of the activities in this direction has been development of equipment to meet the needs of the national economy for apparatus with which to measure electric or non-electric quantities. In the first category, more than 80 types intended for high-priority areas have now been developed and introduced into production. Digital apparatus in particular has been developed; it ensures high precision and sensitivity and affords ease of transmission of measured data, along with the possibility of computer processing of results. A wide variety of digital measurement apparatus has also been developed for measurement of voltage, frequency, distortion, or power, along with a family of oscilloscopes.

In view of the extremely great diversity of measurement and control apparatus for non-electric quantities, the research program has been oriented primarily toward meeting the needs of the machinebuilding industry. Instruments have been developed for resistive tensometry (the most recent accomplishments include an automated digital electrotensometric unit for 100 measuring points which is controlled by a computer, both the unit and the computer having printer outputs and being compatible with standard or specialized computer systems), vibration measurement apparatus, dimensional measurement apparatus, apparatus for measurement of the kinetic and dynamic parameters of machines, and ultrasonic measurement apparatus.

From the technical viewpoint, constant elevation of the metrologic performance level is accompanied by increased use of microprocessors and other computer technology elements in measurement apparatus, in order to increase the degree of automation of measurement and to make it easier to use the results of measurement. Special effort is made to ensure that Romanian-made components are used to the greatest possible extent. Structural or circuit solutions are reconsidered whenever necessary, and an effort is always made to achieve substantial reduction or total elimination of imports.

Activities in research and production also include development of medical electronic apparatus. The quality and complexity of the apparatus produced have improved constantly through the years, so that now there is a complete range of monitors allowing continuous tracking of the principal physiological parameters of patients (see sidebar 3).

In the area of professional electronic components, the primary products designed for use in complex laboratory and industrial systems include ferrite assemblies for telecommunications and closed-circuit television, magnetostrictive transducers for ultrasonic apparatus, and ferrite devices for microwave applications. It has become possible for the first time in the country to carry on mass production of such devices, which are extremely useful in professional radio communications equipment, so that substantial foreign exchange savings are effected by eliminating imports.

The results of Romanian research and production in electronics are finding a large number of varied applications in the broad campaign to improve the organization of and to modernize production processes to contribute to improvement in the quantitative and qualitative parameters of the activities of enterprises and to increase the economic efficiency of these enterprises.

All these accomplishments show that we have a high scientific and technical potential, together with the resources necessary for ensuring development of electronics in the future. We have crossed the threshold of a new stage in which we must make increasingly efficient use of the technological resources available to all of Romanian industry. This great diversity of technologies, combined with know-how and sustained by inventiveness, in effect opens the way to achievements in step with the progress made in the current scientific and technical revolution. Important tasks in this area also derive from the general guidelines of the unified national plan of economic and social development for 1987. These guidelines call for intensification in machinebuilding of redesign of existing products and start-up of production of new ones characterized by higher performance and lower consumption of metal, energy, and labor, with priority assigned to growth of electronics, microelectronics, precision mechanics, and high-performance machine tools.

[Side bar 1] The N23-100 automated system for tensometric measurement at 100 points, which was developed by research personnel at ICSITE in Bucharest, meets the requirements of Romanian enterprises in this area and is also supplied for export. It ensures timely and efficient measurement of mechanical deformation and stresses during development and testing of equipment, machine elements, and industrial installations for the purpose of determining their proper dimensions, lowering consumption of materials, making products lighter, and increasing the reliability of products in use. The system is used to perform automated balancing, switching, and measurement; preprogramming of the measurement process; digital display and automatic print-out of measurement results.

The main performance features of the system are use of resistance-type or inductance-type transducers, along with the possibility of measuring various quantities of interest in industrial practice in addition to mechanical deformation; automatic balancing of transducer bridges in the plus or minus 5 millivolts per volt range; programming of the following measurement process parameters: the point switching cycle--0.2, 1, 2, 10, 20 seconds per point; measurement recurrence--1, 5, 10, 30, 60, 120 minutes, and 1 cycle or continuous cycles; transducer bridge configuration--1/1, 1/2 (1/4) bridge; sensitivity scale--0.5, 5, 50 millivolts per volt (1,000, 10,000, 100,000 microns per meter); measurement print-out protocol, containing the measurement point number, transducer bridge configuration, 4-digit measurement data, decimal point, and sign; measurement unit: microns per meter ($k = 2$).

The unit is modular in design, in 3 METROSET cabinets, plus N2324MB/E0601S printer made by IEMI Bucharest. Power supply of 1984-242 volts, 48-52 hertz, 90 volt-amperes.

[sidebar 2] The R 8901 producing oilfield radio control network is in the category of systems for direct remote control of technological processes conducted over a large area. It provides the possibility of controlling up to

240 wells from a central point (dispatcher control center), orders being broadcast to the wells and information being received from them. The transmission channel for this information is designed with ultrashortwave frequency radio telephones. The information transmission proper is accomplished with two types of signals: (a) digital, with multiple-tone frequency code by means of which the remote commands (start, stop, switch to speech mode, interrogation) and remote signals (start, stop, emergency) are transmitted; dual-tone amplitude modulated transmission, by means of which production curves, that is, the dynamogram (stress on the sucker rod as a function of the jack position) and the electrogram (current absorbed by the motor as a function of the jack position), are transmitted. In addition, for some operational needs voice traffic can be directed in the network under the absolute control of the dispatcher control center operator. The R 8901 provides the possibility of exercising direct, prompt, and accurate centralized monitoring of the situation over the entire well park, with the following advantages: 2-3 percent increase in the amount of oil drawn; approximately 12 percent reduction in energy consumed in pumping; a minimum of 10 percent reduction in parking expenses. This network represents a first element in the framework of a system which will ultimately integrate all the technological equipment in producing oilfields (flowing wells, separator parks, injection pumps, etc).

[sidebar 3] The following have been developed to provide the medical network with high technology apparatus and units: a single-channel electrocardiograph, electronic clinical thermometer, electronic hemoglobin meter, Achilles tendon reflexometer, triage audiometer, and portable defibrillator monitor; in the category of physiotherapy apparatus, a diadynamic current therapy apparatus, ultrasonic aerosol apparatus, etc.

There have also been developments in more narrowly specialized fields, such as electrosurgery and cardiology. The electrosurgical apparatus developed at the Cluj-Napoca branch of the institute and manufactured at the local automation element enterprise allows the execution of delicate surgical operations; the parameters of the apparatus are comparable to those of the best made anywhere in the world. A cardiac arrhythmia monitor equipped with a microprocessor provides invaluable assistance to doctors in intensive care units; the information it displays allows among other things continuous monitoring of a patient's condition and evaluating the effect of drugs that have been administered.

6115

CSO: 2702/6

BRAZILIAN COMPUTER TECHNOLOGY

Sao Paulo GAZETA MERCANTIL in English 16 Mar 87 p 6

[Text]

Nicaraguan Planning Minister Dionísio Marengo met Monday in Rio with representatives of Abicomp, the computer industry association, to interest them in selling technology, equipment and services to his country.

Nicaragua is interested in buying software programs for use in both government and private enterprise, he explained, under a proposed \$1 million program sponsored by the United Nations. The country's secondary interest is in acquiring equipment and training technicians, he said.

"The blockade imposed by the U.S. made it impossible for us to buy American computer technology," he said, and this hardship has made Brazil an attractive alternative.

Marengo went to Brasília Tuesday where he delivered a message from Nicaraguan President Daniel Ortega to President José Sarney expressing solidarity on the decision to suspend interest payments on the foreign debt.

/9274
CSO: 3699/61

END

25

This is a U.S. Government publication. Its contents in no way represent the policies, views, or attitudes of the U.S. Government. Users of this publication may cite FBIS or JPRS provided they do so in a manner clearly identifying them as the secondary source.

Foreign Broadcast Information Service (FBIS) and Joint Publications Research Service (JPRS) publications contain political, economic, military, and sociological news, commentary, and other information, as well as scientific and technical data and reports. All information has been obtained from foreign radio and television broadcasts, news agency transmissions, newspapers, books, and periodicals. Items generally are processed from the first or best available source; it should not be inferred that they have been disseminated only in the medium, in the language, or to the area indicated. Items from foreign language sources are translated. Those from English-language sources are transcribed, with the original phrasing and other characteristics retained.

Headlines, editorial reports, and material enclosed in brackets [] are supplied by FBIS/JPRS. Processing indicators such as [Text] or [Excerpts] in the first line of each item indicate how the information was processed from the original. Unfamiliar names which are rendered phonetically or transliterated by FBIS/JPRS are enclosed in parentheses. Words or names preceded by a question mark and enclosed in parentheses were not clear from the original source but have been supplied as appropriate to the context. Other unattributed parenthetical notes within the body of an item originate with the source. Times within items are as given by the source.

SUBSCRIPTION/PROCUREMENT INFORMATION

The FBIS DAILY REPORT contains current news and information and is published Monday through Friday in 8 volumes: China, East Europe, Soviet Union, East Asia, Near East & South Asia, Africa (Sub-Sahara), Latin America, and West Europe. Supplements to the DAILY REPORTs may also be available periodically and will be distributed to regular DAILY REPORT subscribers. JPRS publications generally contain less time-sensitive information and are published periodically. Current JPRS publications are listed in *Government Reports Announcements* issued semi-monthly by the National Technical Information Service (NTIS), 5285 Port Royal Road, Springfield, Virginia 22161 and the *Monthly Catalog of U.S. Government Publications* issued by the Superintendent of Documents, U.S. Government Printing Office, Washington, D.C. 20402.

U.S. Government offices may obtain subscriptions to the DAILY REPORTs or JPRS publications (hardcovers or microfiche) at no charge through their sponsoring organizations. DOD consumers are required to submit requests through appropriate

command validation channels to DIA, RTS-2C, Washington, D.C. 20301. (Telephone: (202) 373-3771, Autovon: 243-3771.) For additional information or assistance, call FBIS, (703) 527-2368, or write to P.O. Box 2604, Washington, D.C. 20013.

The public may subscribe to either hardcover or microfiche versions of the DAILY REPORTs and JPRS publications through NTIS at the above address or by calling (703) 487-4630. Subscription rates will be provided by NTIS upon request. Subscriptions are available outside the United States from NTIS or appointed foreign dealers. Back issues or single copies of the DAILY REPORTs and JPRS publications are not available. New subscribers should expect a 30-day delay in receipt of the first issue.

Both the DAILY REPORTs and the JPRS publications are on file for public reference at the Library of Congress and at many Federal Depository Libraries. Reference copies may also be seen at many public and university libraries throughout the United States.