

020107

JPRS-UMA-86-065

18 NOVEMBER 1986

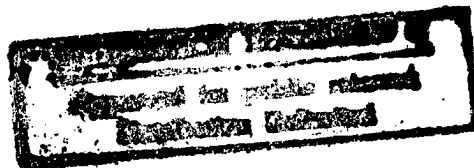

19981104 131

USSR Report

MILITARY AFFAIRS

FOREIGN MILITARY REVIEW

No 5, MAY 1986

DTIC QUALITY INSPECTED 3

FBIS

FOREIGN BROADCAST INFORMATION SERVICE

REPRODUCED BY
U.S. DEPARTMENT OF COMMERCE
NATIONAL TECHNICAL
INFORMATION SERVICE
SPRINGFIELD, VA. 22161

11
88
A05

NOTE

JPRS publications contain information primarily from foreign newspapers, periodicals and books, but also from news agency transmissions and broadcasts. Materials from foreign-language sources are translated; those from English-language sources are transcribed or reprinted, with the original phrasing and other characteristics retained.

Headlines, editorial reports, and material enclosed in brackets [] are supplied by JPRS. Processing indicators such as [Text] or [Excerpt] in the first line of each item, or following the last line of a brief, indicate how the original information was processed. Where no processing indicator is given, the information was summarized or extracted.

Unfamiliar names rendered phonetically or transliterated are enclosed in parentheses. Words or names preceded by a question mark and enclosed in parentheses were not clear in the original but have been supplied as appropriate in context. Other unattributed parenthetical notes within the body of an item originate with the source. Times within items are as given by source.

The contents of this publication in no way represent the policies, views or attitudes of the U.S. Government.

PROCUREMENT OF PUBLICATIONS

JPRS publications may be ordered from the National Technical Information Service (NTIS), Springfield, Virginia 22161. In ordering, it is recommended that the JPRS number, title, date and author, if applicable, of publication be cited.

Current JPRS publications are announced in Government Reports Announcements issued semimonthly by the NTIS, and are listed in the Monthly Catalog of U.S. Government Publications issued by the Superintendent of Documents, U.S. Government Printing Office, Washington, D.C. 20402.

Correspondence pertaining to matters other than procurement may be addressed to Joint Publications Research Service, 1000 North Glebe Road, Arlington, Virginia 22201.

Soviet books and journal articles displaying a copyright notice are reproduced and sold by NTIS with permission of the copyright agency of the Soviet Union. Permission for further reproduction must be obtained from copyright owner.

18 NOVEMBER 1986

USSR REPORT
MILITARY AFFAIRS
FOREIGN MILITARY REVIEW

No 5, May 1986

Except where indicated otherwise in the table of contents, the following is a complete translation of the Russian-language monthly journal ZARUBEZHNOYE VOYENNOYE OBOZRENIYE, published in Moscow by the Ministry of Defense.

CONTENTS

Lead Editorial: Growth of Imperialist Threat (pp 3-6).....1

GENERAL MILITARY PROBLEMS

Exercise AUTUMN FORGE-85 (pp 7-14)
(V. Stroganov, V. Kulikov).....7

Bundeswehr's "Cultural Wealth" (pp 14-19)
(N. Yvayskiy) (not translated)

Military Use of Electromagnetic Accelerators (pp 19-22)
(A. Lomov, T. Arinin).....16

GROUND FORCES

Urban Combat (pp 23-27)
(A. Ryzhkov).....23

U.S. Light Infantry Division (pp 27-30)
(K. Volodin).....29

Improving British Army Aviation's Combat Potential (p 30)
(V. Titov) (not translated)

Help for the Commander. CHAPARRAL Air Defense Battery. U.S. Armored
Division VULCAN Self-Propelled Air Defense Artillery Battery and
STINGRAY Air Defense Missile Battery. U.S. Armored Division
STINGRAY Air Defense Missile Battery. (p 31)
(not translated)

AIR FORCES

5th Joint Tactical Aviation Command (pp 33-37)
(P. Andreyev) (not translated)

Command and Control of U.S. Air Forces (pp 38-41)
(V. Tamanskiy, V. Grebshkov).....35

U.S. Overhead Reconnaissance Equipment (pp 41-45)
(N. Gavrilov).....41

Aircraft of Capitalist Countries (p 48)
(not translated)

NAVAL FORCES

Federal Republic of Germany Navy (FRGN) (pp 47-55)
(Yu. Kravchenko).....49

U.S. Nuclear Submarine Communications (pp 56-59)
(A. Markov).....60

BEAR-Class Coast Guard Ships (p 60)
(N. Nikolenko) (not translated)

MILITARY ECONOMY AND INFRASTRUCTURE

Japanese Shipbuilding (pp 61-70)
(Yu. Shitov).....67

NATO Military Pipelines in Central Europe (pp 71-74)
(V. Elin).....78

INFORMATION, EVENTS, FACTS

New Variant of the TOMAHAWK Cruise Missile (p-75)
(I. Karenin).....83

Arming the British Ground Forces with New BMPs (p 75)
(S. Anzherskiy) (not translated)

Bundeswehr Aircraft in Portugal (p 76)
(S. Machkov) (not translated)

New French Landing Ship-Dock (pp 76-77)
(A. Melnikov) (not translated)

New U.S. Navy Minesweeping Helicopter (pp 77-78)
(V. Kutsev) (not translated)

Soft Containers for Delivery of Fuel (p 78)
(V. Mitrich) (not translated)

Answers to Page 46 (p 78)
(not translated)

FOREIGN MILITARY CHRONICLE (pp 79-80)
(not translated)

COLOR INSERTS

JAGUAR Fighter-Bomber * British LYNX-3 Combat Helicopter * American Short-Range Self-Propelled CHAPARRAL Air Defense Battery * HESSEN D184, West German HAMBURG-Class Guided Missile Destroyer

FOREIGN MILITARY REVIEW

LEAD EDITORIAL: GROWTH OF IMPERIALIST THREAT

Moscow ZARUBEZHNOYE VOYENNOYE OBOZRENIYE in Russian No 5, May 86 (Signed to press 11 May 86) pp 3-6

[Editorial; "Imperialism: The Threat To Peace Grows"]

[Text] The most burning question for mankind today is that of war and peace. The course of imperialisms has led, as emphasized in the CPSU Central Committee's Political Report to the 27th Party Congress, to the conclusion of the current century of world politics under the question; "will mankind be able to escape nuclear danger or will the policy of confrontation be elevated, thereby increasing the probability of nuclear conflict." Analyzing the progress and nature of the First World War, V. I. Lenin sagaciously noted that the development and employment of ever more destructive military technology could lead to "undermining the very conditions of the existence of human society" (Collected Works, vol. 36, page 396). Such a danger now, when there are on the earth enough weapons to destroy the population of the world many times over, has become reality.

Socialism considers the salvation of humanity from this threat as its historical imperative. A world without wars and without weapons, that was the ideal of socialism defined in the CPSU's Program. This definition contains the entire succession of the principles of Soviet foreign policy laid out by Lenin, which flows from the humane nature of socialist society, freedom from exploitation and oppression, and absence of classes and social groupings which have an interest in encouraging wars.

In the resolution adopted by the 27th Party Congress, it states: "The principle goal of the CPSU's foreign policy strategy consists of providing the Soviet people the possibility of working under conditions of stable peace and freedom." The peaceloving Lenin policy is legislatively incorporated in the USSR's Constitution. It is reflected in the most important foreign policy peace initiatives. The announcement of the General Secretary of the CPSU Central Committee, M. S. Gorbachev, on 15 January 1986, of a wide-scale program of radical measures directed toward freeing the earth by the end of the century from weapons of mass destruction and from the terror of nuclear catastrophe, has special significance.

The 27th CPSU Congress gave life to an important initiative, an idea for creating a general system of international security. Its principle bases have been formulated. They have an all-around, complex, constructive character. Together they, for the first time, encompass all aspects of modern understanding of international security; military, political, economic and humanitarian.

Marxism-Leninism revealed, and historical experience reliably confirmed, that the source of wars and arms races is concealed in the capitalistic societal system. Lenin spoke of the organic connection between capitalism and militarism, emphasizing that militarism as a "result" and a "living revelation" of capitalism reveals its exploitative, greedy, expansionistic essence (Collected Works, vol. 17, p.187).

Imperialism, the culprit in two world wars, in which 65 million people perished and 110 million were injured, is currently threatening a third world war. The first to use nuclear weapons, it now places the achievements of human genius to work creating weapons with incredible destructive power. The policy of imperialistic circles, having tried to gain social revenge for their historical destruction and prepared to sacrifice for this the fate of entire nations, is increasing the danger to the point where such weapons may be launched from the move. The more strongly the course of historical development undermines the imperialist position, the more policies which are hostile to the interest of people become the policies of its most reactive forces.

Imperialism's internal driving forces and its very social-economic essence, push it into military confrontation. Problems and crises being experienced by the world of capital arise in its own depths, and are the logical results of internal antagonistic contradictions of the old society. Unable to cope with the aggravations of the descending phases in the development of capitalism, the ruling circles of imperialistic countries are resorting to methods which are known to be unable to save a society, doomed by history itself, and are trying to find an escape in a military direction. It was noted in the CPSU Central Committee's 27th Party Congress political report that "Imperialism, by the force of its social nature, constantly generates aggressive, adventuristic policies,"

The United States is the locomotive of such a policy. The present American administration's plans, sinister for the peoples of the world, are reflected in its adopted armed strategy of "direct confrontation." In the words of the minister of defense, C. Weinberger, it has as its principle goal the achievement of "full unquestionable" military superiority, restoration of the "leading role of the U.S. in the world," and active opposition to the Soviet Union in "defense of Washington's vital interests" in diverse parts of the planet. United States ruling circles place special emphasis on training for and delivery of preemptive nuclear attacks on the USSR and other socialist countries.

The unprecedented nuclear and conventional arms race is a concentrated reflection of American imperialism's policy through which it hopes to achieve world hegemony. Its most important component, constituting a challenge to all mankind, is the "Starwars" program, or the so-called "Strategic Defense

Initiative," which is directed toward militarization of space. Supporters of space weapons assert that if they pursue the two-sided defensive goals, they will not suffer the threat of personnel losses and destruction, and it promises someday to render nuclear weapons obsolescent.

However, in reality, this program envisions creating not only antimissile defenses, but also space weapons, and sharpens the arms race, increases the threat of war, and, at a given moment, may make it inevitable. The "Strategic Defense Initiative" does not serve the cause of strengthening peace, as Washington asserts, but the exacerbation of the international situation, as the well-known West German scholar W. Albrecht correctly believes, "In forcing the development of space weapons the U.S. is attempting to achieve military superiority to put pressure on the socialist states." It is perfectly obvious that the country which covers itself with an "antimissile shield" and accomplishes thereby unprecedented programs in developing new systems of nuclear and other weapons, is not concerned about defense, but seeks the possibility of discovering a capability to make an unanswerable preventive nuclear attack.

Realization of the "Star Wars" program could make human civilization a hostage of machines and that means also of technological foibles and weaknesses. "More and more specialists from various American research institutes," the NEW YORK TIMES wrote, "are expressing the opinion: the Challenger disaster made clear that plans to place weapon systems in space are fraught with deadly danger for mankind."

Besides developing the means for warfare in space, the United States is carrying out a broad program designed to introduce, in the shortest possible time, new weapon systems, primarily for the strategic offensive forces, including MX and MINUTEMAN intercontinental ballistic missiles, TRIDENT nuclear submarine launched missiles, B-1B STEALTH strategic bombers, and long-range land- air- and sea-launched cruise missiles. Without consideration of the will of the people, and their desire for peace, U.S. ruling circles continue to deploy new first-strike nuclear missiles in Western Europe. All of the planned 108 PERSHING II missiles have been delivered to launch positions in the FRG. Washington refused to join the proposal of the Soviet Union of August 1985, of a moratorium on nuclear testing.

At the same time, Western strategists are carrying out active preparation for conducting aggressive military operations with conventional weapons. They present a special danger since, at the present time, they are approaching the tactical nuclear weapon in combat efficiency and already are spreading death and destruction on the planet. Thus, in local wars and military conflicts, unleashed through the fault of imperialist circles, over 20 million people have been deprived of life in years since World War Two.

At present, a huge arsenal of conventional weapons has been built up but they continue to supplement them with new designs which are more accurate and powerful. The NATO countries are planning to expend hundreds of billions of dollars on the non-nuclear arms race. The structure of units and organizations in the bloc armed forces are being correspondingly improved. All of this is expected to significantly raise their striking power, fire power and mobility.

The increase in their military expenditures shows the ever-growing scope of U.S and NATO militaristic preparations. During the years of the Reagan administration the American military budget has risen by a factor of more than 1.5, purchases of weapons have doubled, and expenditures on research in the field of developing new weapons of mass destruction have risen by 80 percent. Altogether during the past five years, the Washington administration has lain over one trillion dollars on the altar of war.

This dangerous tendency to increase militaristic expenditures will continue in the future. In fiscal year 1987, Pentagon appropriations are planned to reach record levels of 311.6 billion dollars. In 1988, for every 100 dollars invested in civilian sectors of the economy, 87 dollars will be spent for capital investment in the military sector, compared with 38 dollars in 1980. And this is during a time when, according to professional organizations, up to 40 per cent of the population of the U.S. lives in poverty or on the edge, every fourth child in this richest of capitalist states goes to bed hungry, and during the past five years more children have perished in that country from malnutrition than American soldiers were killed during the "filthy war" in Indochina.

The unprecedented scale of the arms race, the gigantic military expenditures, are imperialism's greatest crimes before mankind. The desperate thirst for profit engulfs them and the striving for world hegemony of a sinister union of fabricators of death and imperialistic state power, this is the buttress of extreme reactionisms, the constant and growing source of military danger. As an illustration of the nature of this activity, let us employ a historical analogy. There is a tale that the Roman emperor Probus paid with his life, having decided to pursue an intention to achieve "general peace." He was killed by his own soldiers who were fed by war, enriched by the plunder they took from those they conquered. A similar, greedy, aggressive view of peace is held today by those who live by the arms race, who most zealously conduct the policy of adventurism and aggression - the military monopoly, generals, government bureaucrats, the ideological apparatus, militaristic science, all combined in the military-industrial complex.

V.I. Lenin, noting the interest of monopolies in expansionistic wars in his time said, "War - a 'terrible' thing? Yes. But it is a terribly lucrative thing." (Collected works, vol. 26, p. 377). Every day there are reports of some greed that big business is attempting to turn into a new militaristic law. The active mechanism of the military-industrial complex is particularly responsible in the case of the star wars program. At the beginning of 1986, the Pentagon issued 1,500 contracts for development of space weaponry. The West German magazine DER SPIEGEL discovered that this program is an offspring of the military-industrial complex which regards it as a guarantee of its daily bread for the next century. "In exchange," the magazine writes, "the industrialists made the government an offer they couldn't refuse: world domination."

The United States conducts a policy of open robbery in the so-called "third world." Contrary to sound thinking, they attempt to substitute the solution for the cardinal problem of modern times - radical reduction of nuclear weapons and a rejection of militarization of space - by a discussion of ways

of settling regional conflicts. Washington arbitrarily believes that these conflicts are the result of rivalry between East and West and in every non-favorable event sees the "hand of Moscow."

However, the facts show that it is not so, but that imperialism, not wishing to learn the political realities of the modern world and ignoring the will of sovereign peoples, tries to rob them of their right to chose the path of development and threatens their safety. Therein lies the principal reason for the outbreak of conflicts in various regions of the world. In conducting a policy of neo-colonialism, imperialism is attempting to undermine the sovereignty won by young states and increase control over them. It tries to draw these countries into a militaristic orbit and to use them as staging areas for their aggressive global politics. For this purpose, imperialists employ methods of military pressure and economic dictate, and support internal reactionism.

In recent times, such a course has come to be called "neoglobalism" in Washington. They want to convince the world that the issue is a new stage of the struggle for "democracy" against "communist expansionism." Actually all of this is just imperial politics designed for subjugation, disruption, and suppression of national liberation movements and anti-imperialistic regimes.

Washington subjects countries which appear to present favorable opportunities for intervention in conflict situations in Asia, Africa, and Latin America, to open and crude pressure. The imperial, plundering face of the neoglobalistic policy was clearly revealed during the aggressive actions against Libya. The U.S. gave substantial (including military) aid to Angolan antigovernment bands, Afghan bushmen, Nicaraguan "contras," Cambodian cut throats, and Israeli aggressors. And to justify these miserable activities, inventions about "Soviet expansionsism" are started.

"The big lie - an old wives' tale concerning the so-called communist threat and 'imperial evil' plus anti-communism," said G. Hall, General Secretary of the U.S. Communist Party, "is the most enormous propaganda operation in the spirit of 'brain washing' in all of history. It is a develish ideological trap. It is actually opium for the people. It is a propagandistic narcotic, which reverses reality and its opposite."

Imperialism has unleashed against the forces of peace and progress a wide-scale "psychological war," which could not be qualified as anything but a special form of aggression by reactionary militant circles, which tramples on people's sovereignty, history, and culture. This is also a direct political-psychological preparation for war, having nothing in common with ideological dispute, for in the West people are taught to look on anything which is unfavorable to imperialism through a gunsight. The class enemy has created a gigantic machine for massed propaganda, equipped with state-of-the-art technical resources, which is disposed of by a huge group of trained haters of socialism. Among the population of capitalist countries are dispersed various types of fabrications and cock-and-bull stories to bring about skepticism about socialism and anything which does not justify terror of it, to discredit it as a social system.

There has never been such a great danger hanging over the planet. But there has also never been such a real possibility to preserve and strengthen peace, since the potential of the power of peaceloving people has grown and the sphere of imperialist domination has shrunk. The historic achievements of socialism have established military-strategic parity between the USSR and U.S. and the Warsaw Pact and NATO, to upset the calculations of aggressive imperialist circles for victory in a world nuclear war. This has caused the CPSU to provide in its Program the comment that "the fatal inevitability of world war doesn't exist. To prevent war and save mankind from catastrophe is possible. In this is the historic calling of socialism, of all progressive people, of the peaceloving power on our planet."

However, as long as there is the danger of imperialists unleashing aggression, military conflicts, and various forms of provocation, it is necessary to devote unslakened attention to strengthening the defenses of the USSR, to improving its security. "It is no secret that a scenario of nuclear attack does not exist with us," - as emphasized in the Political Report of the Central Committee of the CPSU at the 27th Party Congress. "We have no right to plan on their employment." Soviet soldiers, in combat unity with their comrades from the countries of the socialist fraternity, must display the highest vigilance, always be prepared to cut short the intrigues of imperialist circles against the USSR and its allies, and to defeat any aggression.

COPYRIGHT: "Zarubezhnoye voyennoye obozreniye," 1986

9355

CSO: 1801/216

FOREIGN MILITARY REVIEW

EXERCISE AUTUMN FORGE-85

Moscow ZARUBEZHNOYE VOYENNOYE OBOZRENIYE in Russian No 5, May 86 (Signed to press 11 May 86) pp 7-14

[Article by Lt Col V. Stroganov, Lt Col V. Kulikov; "Exercise AUTUMN FORGE-85"]

[Text] The positive processes, occurring in the world, connected with the increase in the activity of progressive peace-loving forces in the fight to relax tension and to eliminate the threat of war, are running into extremely hostile opposition from the West's most reactionary circles. It is evident in the attempts by the enemies of detente to use any means to undermine the basis of trust between the governments of various social systems. No stone is being left unturned--from the unfolding of a wide anti-Soviet propaganda campaign to the implementation of an armed forces modernization program, unprecedented in scope, and aimed at achieving decisive superiority over socialist countries. The U.S. and NATO commands are striving to raise the combat readiness of the North Atlantic bloc countries' armies, their strike and nuclear fire power, and strategic and operational mobility to a qualitatively new level. According to their estimates, the implementation of the military programs will allow primarily the offensive strike capabilities of the strategic and tactical formations to be increased due to their being equipped enmasse with highly accurate short-range and long-range weapons, the sharp reduction in strategic deployment times, and the wide introduction of automated control systems.

The reequipping of NATO's joint armed forces is being accompanied by the intensification of research in the realm of military theory. Military strategic concepts and the main tenets of operational art and tactics are being reviewed which is being reflected in the operational and tactical training of the armed forces branches and troop arms. During numerous exercises, the views of the bloc's command on the character of a modern war and the new forms and methods for employing the armed forces are verified; the organizational structures for troop formations are approved; and the effectiveness of weapons systems and combat equipment entering into the inventory are assessed.

As reported in the foreign press, according to the plans of the bloc's national and coalition commands, several hundred different measures for the operational and tactical training of troops and the fleet have been carried

out in 1985 alone,. The main ones consisted of a series of autumn exercises of the NATO countries' national and joint armed forces, conducted under the name AUTUMN FORGE-85. It consisted of command-and-staff, troop and special exercises and training periods, varying according to scale, objectives, and the participants, and organized against a single operational-strategic background. Such dangerous games by the militarists are conducted yearly during the period from September to November, starting in 1975. They are, in essence, the total measure of the yearly operational and tactical training cycle for the bloc's forces and troops. The importance of the AUTUMN FORGE exercises is primarily clarified, in that they are used by the North Atlantic bloc's command to verify, in practice, new tenets of military theory, to analyze their armed forces capabilities to conduct an aggressive war against the Warsaw Pact countries, and to find the most optimum forms and methods of implementing the achieved and forecasted combat potential of NATO's joint armed forces.

The AUTUMN FORGE-85 exercises were conducted against the background of a complicated military-political situation building-up in the world, and having the character of a vividly manifested military provocation. Many of them were conducted in the immediate vicinity of the Warsaw Pact countries' borders (Fig. 1). They had a clear anti-Soviet direction and were used by the bloc's military-political leadership to demonstrate the NATO countries' "Atlantic solidarity" and their readiness to use the entire weapons arsenal of armed conflict to achieve their aggressive military-political objectives.

Even the official Western propoganda organs did not attempt to conceal the scale of these exercises. It was noted, that approximately 250,000 servicemen, up to 200 warships and approximately 300 main class ships of the armed forces of 11 NATO countries participated in just 25 exercises of the mentioned series. Wide regions--from North Cape (Northern Norway) in Europe to Eastern Turkey in Asia, and also the northern part of the Atlantic Ocean, encompassed their operations arena.

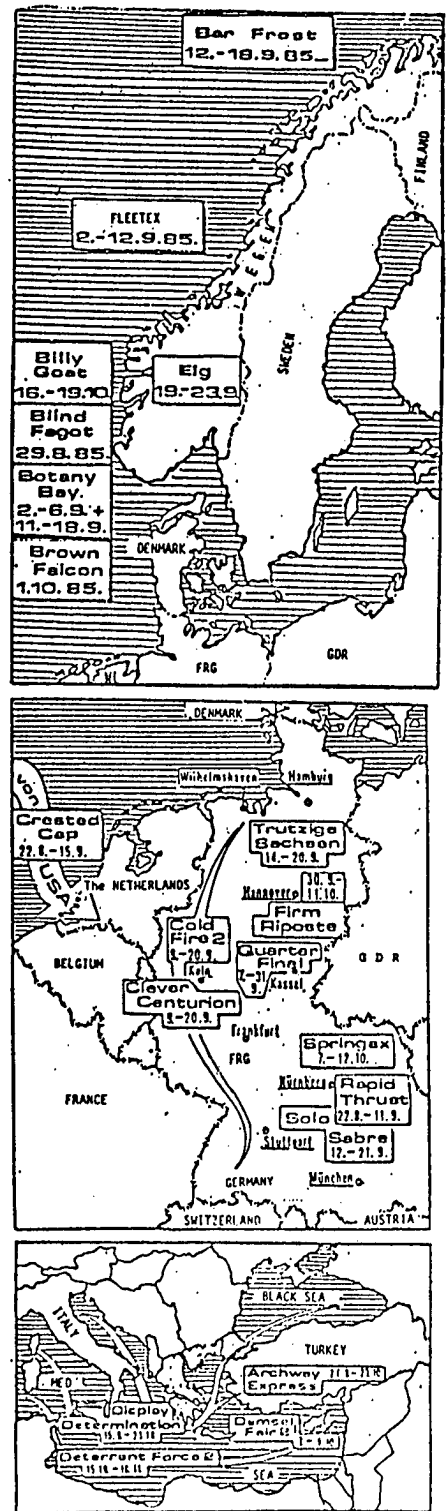

Figure 1. Regions for Conducting Principal NATO Autumn Exercises

According to the official press information from the NATO joint armed forces headquarters center in Europe, the most characteristic and important exercises of the AUTUMN FORGE-85 series were the following:

-- In the Northern European TVD: BAR FROST, conducted by NATO's joint armed forces, and FLEETEX-85, conducted by large naval formations (in northern Norway); BOTANY BAY-85 and BALTIC OPERATION-85, conducted by large NATO naval formations and also BROWN FALCON-85 (in the Baltic Straits zone), conducted by large air force formations.

-- In the Central European TVD: the West German First Army Corps troop exercises, TRUTZIGE SACHSEN (West German formations and units), CLEVER CENTURIAN (Belgian) FIRM RIPOSTE (Dutch), QUARTER FINAL (English), SCHWERER DAMPFHAMMER (West German), SPRINGEX (American-West German), SOLO SABRE (Canadian); the Allied Air Forces exercises in the TVD, COLD FIRE-85; and the U.S. Air Force exercises for the transfer of tactical aircraft from American to Europe, CRESTED CAP.

-- In the Southern European TVD: the exercises of NATO's joint armed forces, DISPLAY DETERMINATION-85; large joint naval formations, DAMSEL FAIR-85 and DETERENT FORCE-2; NATO force mobilization exercises, ARCHWAY EXPRESS, were conducted simultaneously in Eastern Thrace. They all ended in the beginning of November.

Depending upon their scale, the bloc's coalition commands in the European TVDs, and the national armed forces commands--the commanders of the corresponding large strategic and tactical formations--led the NATO joint force exercises. The coordination of the joint and national commands' activities during the autumn exercises was entrusted to the NATO joint armed forces C-in-C in Europe, Army General B. Rodgers. Their main goal included the complex verification of the plans for the immediate preparation and conduct of the first operations in the initial period of a limited war against Warsaw Pact countries using conventional, chemical and nuclear weapons.

As the foreign press reported, as in previous years during the autumn exercises, the NATO command's views on the character of a modern war, and the forms and methods the armed forces employment were verified; the joint and national commands' mobilization and operations plans were verified and clarified; the level of troop (force) combat readiness and the effectiveness of new weapon systems and combat equipment were assessed; the influence in the growth of NATO joint armed forces groupings' combat capabilities to conduct high-maneuver combat operations during the first operations of the initial period of war according to the concepts of "AirLand Battle" and "Combating the Second Echelon (Reserves)" were analyzed; and also the issues dealing with the organization of reliable control and the multi-lateral logistic support of troops on the battlefield were worked out.

The main attention during AUTUMN FORGE-85 was paid to conducting troop and command and staff exercises. The method of their organization was verified, and the large spacial scope and use of large, various nationality troop (force) groupings with the participation of all NATO military leadership echelons permitted, as Western specialists figure, the concept of the first

operations in the beginning period of war or their fragments in the complete volume at various command levels to be verified.

Stemming from the special-purpose direction of the conducted operations, foreign military experts conditionally divided the AUTUMN FORGE-85 exercises into two phases.

In the first phase (September-October), the main attention was devoted to improving the transition of the armed forces from a peacetime posture to a wartime stance, to reinforcing existing NATO joint armed force troop groups in Europe, and also to working out the plans for the operational deployment of troops (forces), the organization and conduct of combat operations during the initial period of a limited war against the Warsaw Pact countries using conventional fire systems and chemical weapons.

Issues concerning the transition from a limited war using conventional weapons to a nuclear war (in command and staff exercises) were worked out in the second phase. All the bloc's staffs and the national armed forces of the member countries participated in them.

A large part of the time was spent on actually verifying the plans for conducting a conventional war in Europe and the Atlantic. Thus, as foreign information agencies assert, practically all the large (division and above) exercises, clearly surpassed the scale of those officially announced, both with respect to the participants and the executed missions. More than this, they were not purely national since the units and subunits from several bloc countries participated, which allowed the issues of their joint employment to be worked out thoroughly.

The combat operations plan in the AUTUMN FORGE-85 series was executed almost simultaneously in all European TVDs. The exercises, conducted in the most important strategic regions, attracted the Western military press' main interest, especially the field exercises of the FRG's First Army Corps, TRUTZIGE SACHSEN; the integrated exercises of Great Britain's armed forces BRAVE DEFENDER; and the exercise of NATO's mobilization force, ARCHWAY EXPRESS.

As it was reported, according to its scale, the TRUTZIGE SACHSEN exercise clearly exceeded the limits of the exercises officially announced by the Bundeswehr command. Besides West German troops, the following units and subunits participated in it: American (from 2 BRTDs), English (4 BRTDs) and Dutch (41 MBRs), in all 9,000 men. The combat operations were conducted in the immediate vicinity of the GDR's border in the extensive region of the Lunebursk wasteland between the Elba and Wesser rivers. While working out the issues regarding the offensive, a great deal of attention was paid to crossing water barriers, and the combat capabilities of modern weapon systems were analyzed (including LEOPARD-2 West German tanks, Bo-105 combat helicopters and ROLAND SAM systems).

In the period from 2-13 September, 1985, the exercises of the English armed forces were carried out under the conventional name BRAVE DEFENDER, the main goal of which was the complex verification and actual development of the plans

for conducting combat operations on the British Isles. Great Britain's military leadership used the defense staff, the staffs of the armed force branches and military districts, formations and units, deployed on the country's territory, anti-econnaissance and police subunits, and also the personnel from American military bases in this large operational-strategic exercise. In all, more than 65,000 men participated in the exercises, including approximately 700 American servicemen, 12,000 reservists (called-up for this period), of them 7,000 for the territorial troops, 2,500 for the territorial defense subunits, and 2,500 for the restaffing of regular troop subunits.

According to the exercise plan, the "enemy" delivered a strike on a large portion of the country's territory, and airborne assault troops and diversionary subunits were employed to capture 200 military and administrative-economic objectives. For the purpose of kindling hatred toward the socialist countries, the Soviet Union's armed forces were established in the enemy role. Seven companies from the 1st Army Corps, located in West Germany, were allocated for this. A significant part of the personnel were civilians, but with special ranks. The transfer of "enemy" troops from FRG territory was carried out by air and by sea.

As the Western press emphasizes, the exercises of this type, with the actual development of missions for combating enemy airborne assault units and diversionary subunits simultaneously throughout the country's entire territory, was conducted in Great Britain for the first time in the post war period. The general expenditures for this new militaristic provocation was approximately 4 million dollars.

In developing the plans for unleashing and conducting war in Central Europe, the North Atlantic Union's command has not withheld attention to its flank groupings. In particular, in the exercises it tried not only to verify the readiness of troops deployed in the Northern European and Southern European TVDs, but also to demonstrate its "resolve" to reinforce them significantly in crises situations.

The most significant and characteristic [exercise] in this plan was the NATO forces mobilization exercise, ARCHWAY EXPRESS, conducted from 24 September to 23 October, in Eastern Thrace (it developed in three phases). It was conducted for the purpose of actually working out the entire aggregate of issues, connected with the transfer of troops to the region, where, according to the bloc's leadership opinion, a crisis situation arose, and also for conducting combat operations with these forces simultaneously with Turkish formations and units.

Along with the Turkish ground forces and air forces, there were combat battalions and subunits for supporting the mobile ground forces, which Belgium, the FRG, Italy, Great Britain and the U.S. had assigned as well as tactical aviation squadrons of the mobile air force (Belgium, the FRG, and Italy). They numbered approximately 10,000 men and up to 100 combat aircraft.

All the necessary documentation was prepared by the beginning of the exercise; the times and regions of combat operations were agreed upon; the flight routes

for tactical and military transport aircraft were worked out; the loading and unloading airfields for the subunits were designated; and the issues regarding troop logistic and medical support were considered.

The actual transfer of the mobile forces and their operational deployment in the combat employment region was executed during the first phase (24-30 September). Troops and cargo were delivered to Eastern Thrace primarily by air by military transport aviation forces of the member countries, which upon arrival were placed in subordination of the bloc's joint command in the region.

Issues dealing with the organization and conduct of joint combat operations by NATO's joint armed forces in the Southern European TVD were worked out in the second phase of the bilateral exercises (1-10 October).

The return transfer of NATO's mobile force subunits to the permanent basing regions was executed during the third phase (11-23 October).

On the whole, the significant length of the exercises, the direct working out of the issues dealing with the organization and conduct of combat operations took ten days. A great part of the time (more than 60 per cent) was spent on working out the issues dealing with the preparation and transfer of the mobile forces and their operational deployment. As NATO specialists figure, this was made more difficult by the complexity of organizing and executing mass troop transport in a short period of time in view of the utilization factor of transport routes in Europe. In addition, a great part of the time was spent on the ideological cultivation of the local population by the mobile force subunits' personnel, and also on the organization of actual firing and competitions as an applied-military type of sport between the servicemen of various countries.

Besides participating in joint exercises with the ground forces, the air force and navy staffs and formations executed their own specific missions during the autumn exercises. In particular, the Allied Air Force commands paid a great deal of attention to analyzing and developing different variations for employing tactical aircraft and air defense personnel and equipment in the first operations of the initial period of war: assessing the changes in the combat capabilities of air force subunits in connection with the entry of new types of aircraft into the inventory; working out the operational coordination of large strategic formations and units of various nationalities and the coordination with other branches of NATO's joint armed forces in Europe.

According to foreign press testimony, in the beginning, the concept of the bloc's Allied Air Force exercises consisted of the reinforcement of air force groups in the Central European TVD by American units and subunits (the CRESTED CAP exercise), and then the conduct of offensive air operations and the execution of other missions, entrusted to tactical aviation (COLD FIRE-85) in the entire theater of war.

It was also reported that the Allied Air Force primarily worked out the conduct of offensive air operations based on the introduction of new aviation equipment and weapons to the troops. NATO specialists paid a great deal of attention to assessing the combat capabilities of new aircraft (F-16, TORNADO,

and the ALPHA JET) and also to organizing the control of air defense forces and equipment using the E-3A aircraft.

The concepts worked out by U.S. and NATO specialists, such as "AirLand Battle (Engagement)" and "Combating the Second Echelon (Reserves)", exerted substantial influence on working out the issues regarding the preparation and conduct of air operations during the exercises. Accordingly, tactical aviation and PVO force operations were coordinated with the plans for conducting ground force exercises, which provided the capability to work out the entire circle of questions, connected with the combat employment of air force units and subunits, in a situation approaching reality as nearly as possible.

According to foreign military experts' assessments, the naval commands paid the main attention to executing the missions connected with forming various-purpose large operational task forces and formations, and their use in cooperation with other armed forces branches in the first operations during the initial period of war, mainly in the forward zones of the Atlantic and on the maritime flanks of the European theater of war. It is considered, that the main criteria for successfully executing the missions in these regions is the combined, massed use of all armed forces branches, with the navy having a leading role. Thus, the achievement of a war's strategic goals directly depends on the achievement and retention of supremacy in the Norwegian Sea and the eastern part of the Mediterranean, on the timely and reliable blockade of Warsaw Pact country fleets, and also on their successive destruction in the Baltic and Black Seas. Such missions were executed in the exercises BALTIC OPERATION-85, FLEETEX-85, BOTANY BAY-85, DAMSEL FAIR-85, and DETERENT FORCE-85.

Carrier strike groups are considered by the NATO command to be the main, most combat-ready, combat capable and highly maneuverable component of the general purpose force, embodying the bloc navy's main offensive and strike grouping in the Atlantic and Mediterranean Sea. The issues regarding the formation and employment of carrier strike forces were worked out in the most complete fashion in the exercises OCEAN SAFARI-85 and DISPLAY DETERMINATION-85. For example, for working out the plan of the first, it was planned to play through one of the variations of direct preparation, and the unleashing and conduct of combat operations during the initial period of a limited war between NATO and Warsaw Pact countries in the Atlantic TVDs, with regard to the planned growth in the combat capabilities of the bloc's joint armed forces groups.

OCEAN SAFARI-85 was conducted simultaneously with two other exercises: FLEETEX-85, by NATO's joint navy in Northern Norway (the joint operations of the navy, ground forces, and air force for the antiassault coastal defense were worked out), and BOTANY BAY-85 by NATO's joint navy in the Baltic Straits zone (the defense plan for the straits zone and the protection of naval lines of communication).

The foreign press reports that the maneuvers, OCEAN SAFARI-85, which the NATO joint armed forces C-in-C in the Atlantic, Admiral W. McDonald led, were characterized by the presence of much combat equipment: approximately 160 ships, including 3 strike carriers, up to 10 nuclear submarines, the battleship IOWA, and 24 other U.S. Navy ships and 400 aircraft participated in

them. Many of them had nuclear weapons onboard. The specialized airborne warning (DRLO) and control aircraft (AWACS) also participated in the maneuvers.

The bourgeois mass information resources, in explaining the exercise's goals and the missions being executed by the forces, tried to convince the Western man in the street of the "defensive mission" of the Western Atlantic union, the presence of the "Soviet threat," and the necessity for the nuclear and conventional rearmament of the NATO countries. However, the course of the fall exercises convincingly showed that during the training of the staff personnel and troops, the main emphasis was primarily placed on working out offensive missions. This occurred at all levels: from subunits and units to strategic formations.

All the troop exercises were conducted as two-sided in order to make the situation close to that of combat. Consequently, the defending side switched to the counter offensive. Thus, the trainees had the opportunity to thoroughly work out not only defensive, but offensive combat operations.

As the Western press notes, the 1985 autumn exercises confirmed the new trends in the development of the U.S. and NATO military-political leadership's views on the forms and character of wars, which may be unleashed by the North Atlantic bloc against Warsaw Pact countries.

Recently, under the influence of the American "direct Confrontation" strategy, the North Atlantic union's leadership has reconsidered several tenets of NATO's coalition military strategy. In particular, the possibility of conducting a "limited" nuclear war in Europe was acknowledged, in which the main role during the delivery of a first strike would again fall to the medium-range American nuclear missile systems deployed there.

Western military specialists also consider that the next step has been taken on the path to bringing American and NATO strategies together: the methods of achieving political goals in a war against socialist countries without the use of nuclear weapons were actively studied. The issues regarding the employment of nuclear weapons were investigated in the concluding phase of the maneuvers outside the general operational background which had been put together by the end of the exercise. It became possible to state the question in such a way due to the entry of highly accurate long-range conventional weapons into the armament of NATO armies and the promising work being conducted in this realm, as a result of which it is expected that by the end of the present decade, conventional weapons systems will enter the forces which are not inferior to low-yield nuclear ammunition in their fire effects. The NATO leadership required the troops and staff to study the tenets of the new concepts, "AirLand Battle", and "Combating the Second Echelon", to provide the integrated fire destruction of opposing enemy (combat formations) groups to the entire operational depth, to develop decisive superiority on selected axes, not by advance redeployments, but by the delivery of mass fire strikes, and the accomplishment of a troop maneuver directly following this. The role of the so-called "vertical" maneuver has significantly grown in operations (combat), allowing the increased airmobility of formations and units to be more fully utilized. In order to create the air echelon, army aviation units

and subunits, and divisions and corps-- airmobile troops, used for raiding operations in the operational-tactical depth-- have been included in the combat make-up of tactical groups.

As the foreign press reports, the air force commands paid the most attention to working out the issues concerning the preparation and conduct of offensive air operations for the purpose of achieving air superiority, the disruption of enemy troop control, the disruption of his operational-strategic redeployments and the delivery of strikes on the second echelons and reserves. The increase in the depth of direct air support to the ground troops from 25 to 70 km was noted. Tactical aircraft delivered strikes to the entire depth of the division's missions upon the combined-arms commanders' requests.

In the navy, the trend was preserved to make the exercise region close to Warsaw Pact countries' territorial waters, and to use them as a pretense for the permanent presence of NATO's joint navy in the forward zones and the activation of air and naval reconnaissance there.

The character of the missions executed by NATO staffs and troops during the fall exercises confirms the trend pursued since the beginning of the 1980s to construct the Atlantic union's military; the transition of main efforts to prepare the armed forces for the surprise unleashing of a war against socialist countries and the conduct of decisive offensive operations from its beginning, regardless of the destruction systems being used. This testifies to the attempts of the aggressive bloc's bosses to continue the course for achieving superiority over socialist countries and upsetting the existing military-strategic balance between NATO and Warsaw Pact countries.

By increasing the scope of U.S. and NATO military preparations, the intensification of imperialistic forces' aggressiveness requires the further reinforcement of the defensive capabilities of our people and of all socialist countries. The CPSU and the Soviet government is doing all that is necessary in order to maintain the USSR armed forces at complete combat readiness to repel a potential attack.

COPYRIGHT: "Zarubezhnoye voyennoye obozreniye," 1986

9355
CSO: 1801/216

FOREIGN MILITARY REVIEW

MILITARY USE OF ELECTROMAGNETIC ACCELERATORS

Moscow ZARUBEZHNOYE VOYENNOYE OBOZRENIYE in Russian No 5, May 86 (Signed to press 11 May 86) pp 19-22

[Article by Col A. Lomov, Doctor of Technical Sciences, and T. Arinin; "The Military Use of Electromagnetic Accelerators"]

[Text] Efforts by the aggressive ruling circles of the U.S. and the NATO bloc to achieve military superiority over the Soviet Union and the countries of the Warsaw Treaty have led to the search for new principles in creating weapon systems and military technology. Western specialists believe the use of electromagnetic accelerators (EA) which, in their opinion, can be used for several weapons systems, is one trend that started out theoretical but has now brought about the practical materialization of these ideas.

The foreign press reports that efforts to use EAs to project different kinds of bodies were made back in the early twentieth century. The first patent for an electromagnetic gun was issued in 1901. After the First World War, research in this area was conducted in France and the U.S., but during the Second World War, specialists in Germany and Japan also engaged in it.

However, foreign specialists came up with practical designs for them only in the late 1970s. Success in development in this area depends, in particular, on the level of achievements made in electronics. First of all, it was necessary to have small-sized energy storage and supply devices as well as heavy-duty current switching systems with heavy-use reliability. The appearance of unipolar generators, magnetic flux compression generators and compressor units has made it possible to create the first experimental models of EAs for military use. The superiority of an EA over artillery ordnance, for example, lies in the fact that they are more efficient and have a higher projectile delivery velocity.

Judging from reports in the foreign press, the theoretical and experimental results of scientific research into EAs have expanded the possible spectrum of their military use. Hence, at the present time, prospects look good for creating electromagnetic guns to strike ground and air targets, including space objects (satellites and ICBMs). Furthermore, they can be used as launching boosters for missiles and torpedoes, as well as the direct means to launch objects into space, as catapults to decrease the distance in launching

aircraft off aircraft carriers, and as boosters to deliver material supplies into forward positions.

Foreign specialists have had the best results in developing so-called electromagnetic rail guns. This term comes from the mechanical guides or rails, along which, under electromagnetic force, the launched body or projectile moves. The basic elements of this gun are the current guides (most often, electrically-isolated copper ones), an energy supply, a feeder source, and a projectile.

In the foreign press, a body "fired" by an electromagnetic gun is called a projectile or an inert munition. Most frequently it is a cube that functions as a dielectric or a thin-walled cylinder that does not contain an explosive. However, certain common projectiles can be used that can slide along the guides on a special baseplate.

The operating principle of an electromagnetic gun is as follows: (Fig. 1) The current runs along a single mechanical guide and then through a fusible armature located on the projectile base. The circuit is completed through a second guide. The current flowing through the circuit forms a magnetic field which ejects the projectile. The current in electromagnetic guns has on the order of millions of amperes, so the base portion of the projectile forms a plasma arc on which a magnetic field operates. It has been noted that in contrast to common artillery ordnance which use powder charges, the acceleration of the projectile, when it passes through the barrel of an electromagnetic gun, can remain a fixed quantity, even though changes in the strength of the current can be regulated.

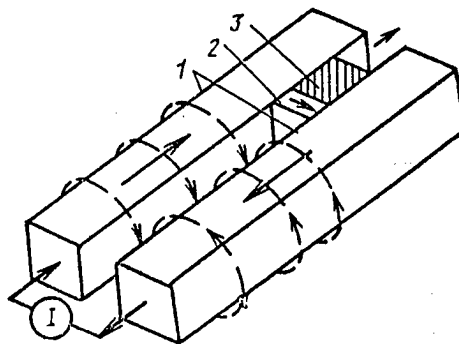

Figure 1: Diagram of the Operating Principle for a Railed Electromagnetic Gun.

1. Guides, 2. Plasma armature, 3. Projectile.

The first experimental foreign electromagnetic gun was created in the early 1970s at the National University of Australia (in Canberra). It had a barrel 5 m long and ejected plastic cubes weighing 3 grams at a velocity of 6 km/sec with an acceleration of 0.3×10^6 . To do this, the gun used as an energy

storage device, a unipolar generator (the height of a two-story house), built initially to study high energy physics. It achieved a maximum energy of 1.6 megaamperes and an energy capacity of 500 megajoules.

The research which started in Australia was continued in the Livermore and Los Alamos scientific research laboratories in the U.S. Laboratory models of two variants of the rail gun were created: one with a small square barrel (1.27 cm side-to-side) to project a projectile weighing 3 grams in a vacuum and one with a larger diameter (5 cm) to eject a projectile weighing 165 grams in atmosphere.

In experiments with the small-barreled gun model (1.8 m long), the following results were obtained: a launch velocity of 10.1 km/sec and an acceleration of 8.4×10^6 . The gun used a magnetic flux compression generator as an energy storage device which was developed through a joint program by the American laboratories cited above. Its operating principle involves stimulating a magnetic current between flat copper conductors. A strip of explosive is laid on one conductor. After it goes off, the conductors come closer together, compressing the magnetic flux. A 16 kW generator generates an impulse (0.4 msec) with a current strength of 0.95 megaamperes. The foreign press reports that while the tests were being carried out on the first electromagnetic guns, the walls of the barrel and the surface of the guides suffered quite a bit from the effects of the plasmic arc and the magnetic field. The "projectile" fragmented and scattered in all directions upon firing.

The model of the gun with the larger barrel was intended for multiple use. However, after firing, its barrel fell apart completely.

The Western press reports that at the present time, substantive progress has been made in the field of developing electromagnetic guns. Prior to 1983, it was believed that EAs could only be used in creating weapon types with established practical utility, since it was believed that projectile velocities could not exceed 3 km/sec in atmosphere. Now foreign specialists assert that with electromagnetic guns it is possible to "shoot" projectiles with velocities on the order of 100 km/sec and destroy ballistic missiles during any stage of their trajectory. In their opinion, for example, an electromagnetic gun is capable of creating, at a range of 2,000 km using inert munitions having a flight velocity of more than 10-20 km/sec, a higher energy density per unit area than other planned future kinds of weapons, including laser and nuclear munitions (25 KT yield). Such an electromagnetic gun is being developed at the present time with the support of those in charge of planning the future scientific research activities of the U.S. Department of Defense.

In the course of experimental research in a vacuum chamber which imitates space, projectile flight velocities have been reached on the order of 8 km/sec and an efficiency coefficient that transforms electric energy into magnetic energy of 40 per cent. Judging from reports in the Western press, the speed-up in work being conducted in the U.S. to create electromagnetic accelerators is explained basically by the possibility of their being used in space. American specialists, based on recent achievements, assert that the ground-testing of systems place to be based in space, are possible within the next 5 to 6 years.

Hence, at the present time, the Livermore and Los Alamos laboratories are developing new variants of electromagnetic guns using guides made of such materials as wolfram, copper with wolfram shielding, and copper alloys with wolfram. A search is also being made for new dielectrics, and high-power generators are being designed. For a space-based electromagnetic gun, Westinghouse has created an energy source based on a nuclear reactor to feed the turbine of a unipolar generator.

The U.S. is currently investigating the possibility of using railed electromagnetic guns to launch various kinds of bodies into space. A launch body form with an ablation cover has already been tested out. The weight, velocity, and necessary energy have been theoretically worked out. Foreign publications have expressed the opinion, that such a launch becoming a reality depends upon the relationship of the aerodynamic characteristics of the projectile and the coefficient of atmosphere resistance. Calculations have shown that with a lot of aerodynamic resistance (a hemispherical nose section), a projectile weighing 100 kg will need a launch velocity on the order of 28 km/sec and an energy of 39 gigajoules to achieve initial velocity in space. With small resistance and the projectile aerodynamically stabilized (weight 4 kg), it will take a launch velocity of 9.5 km/sec and an energy of 0.18 gigajoules to achieve initial velocity in space, and 14.8 km/sec and an energy of 0.44 gigajoules to achieve secondary velocity in space. The need for low resistance has led to an investigation of the possibility of launching a projectile with empennage and base plate from an electromagnetic gun (with a square-shaped barrel). The foreign press reports that in designing the launcher, the developers are trying to decrease its length, but this means increasing the force of the current and acceleration as well as the pressure on the projectile and base plate (if one is necessary). A growth in the force of the current results in an increase in the dimensions and weight of the barrel as well as the energy used for launching.

A second operational principle also exists for the EA which Western specialists are studying. It allows one to substantially lower the pressure on the walls of the barrel, and, consequently, decrease the weight of the electromagnetic gun. Such accelerators are sometimes called coaxial accelerators or accelerators of large mass bodies. The operating principle of the coaxial accelerator is based on the interaction of the electromagnetic field created by stationary drive coils with the projectile. The latter is a complete cylinder which also has coils. Figure 3 depicts the simplest kind of coaxial accelerator with collector brushes, the barrel of which forms a spiral made of square copper wire. The cylinder can have one or more coils that run either inside or outside the shaft.

The coaxial accelerator is a variation on a linear synchronized motor like that used, for example, in railway transportation (a train on a magnetic bedding). The advantages of coaxial accelerators with collector brushes, in foreign experts' opinion, are the simplicity of their design, their rather high efficiency coefficient, and their reliability. Their drawbacks are the rapid wear of the brushes and their ability to operate only at velocities on the order of 1 km/sec.

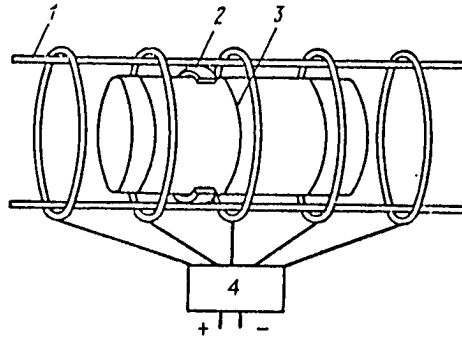

Figure 3. A Diagram of the Elements of One Variant of a Coaxial Accelerator: 1. Feeder bus, 2. Collector, 3. Cylinder coil, 4. Switching system.

It is believed that coaxial accelerators with collector brushes can be used to accelerate bodies of large mass with relatively low velocities.

An experimental model of a coaxial launcher was built at the Massachusetts Institute of Technology. It can be used to launch a remotely controlled glider. The launching mechanism itself (Fig. 4) is 6 meters long, including the feeder source, and is mounted on a motor vehicle. It is intended to launch gliders (weighing about 25 kg) with a velocity of up to 100 meters per second and a load factor of 100.

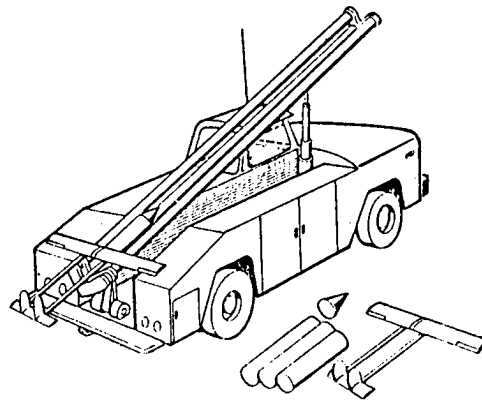

Figure 4. Launcher for a Remotely Controlled Glider

This device looks practically like a mass-produced DC current electric motor with a non-armature core that commutates using common collector brushes attached to a moving cylinder, which, in contrast to a projectile, does not leave the accelerator. The cylinder is built in such a way that it can move inside or outside the spiral guides which serve as a stator. Using the brushes

located on the moving cylinder, a certain portion of the guides are fed and a constant maximum drag is supplied in moving the cylinder along the guides. It is reported that the accelerator's efficiency coefficient exceeds 50 per cent. The energy not used during launch returns to an energy storage capacitor and can be used again during the next launch. Furthermore, between launches it is necessary to recharge the capacitor to the proper level.

The coaxial accelerator can also be used to create electromagnetic guns. One design variation, for example, is the so-called theta-gun which shoots tubular projectiles. The induction coils are synchronized with the movement of the projectile. The active force adheres to the side surface of the entire length of the projectile. Stability in flight is assured through rotation. The demands for simplicity in this design are much less than those for railed electromagnetic guns. The foreign press has publicized two possible variants: in one, induction coils from the barrel, on the inside of which a copper projectile slides along a grooved rod that weakly conducts a current (Fig. 5). In the other variant, the rod is replaced with a second set of acceleration coils located inside the projectile. The inside and outside coils are turned on simultaneously, thereby offsetting the pressure on the projectile.

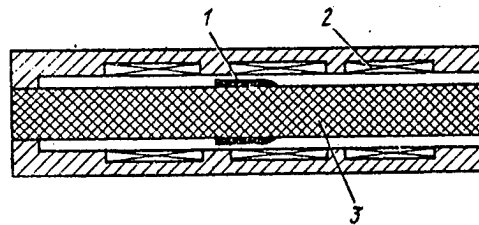

Figure 5: A Diagram of the Principle of a THETA-GUN
1. Projectile, 2. Drive coils, 3. Threaded rod.

In foreign specialists' opinion, the theta-gun, in comparison to the railed electromagnetic gun has the advantages of having increase armor penetrability, greater simplicity with a cylindrical barrel, no need for baseplate, and the assurance that the projectile will rotate. The stability of tubular projectiles in flight has been determined by firing them from regular ordnance. It is intended that the theta-gun will be used to protect the launching positions of intercontinental ballistic missiles, to combat planes and cruise missiles, and as an anti-tank weapon.

Western experts believe that EAs can be used to launch planes from the decks of aircraft carriers. The simplest realization of this method, in their view, is based on using a linear asynchronous electric motor, like that used to start motor vehicles (weighing up to 9 tons) when they are being tested. It is reported that a velocity of 48 m/sec can be achieved in 10 seconds. American specialists assert that the speed it takes for a plane to take off should be approximately two times greater and the time for take-off should be from 2 to 5 seconds. If one figures that the weight of an airplane is almost four times that of a motor vehicle, then the drag forces on the engine ought to be 30 times greater. In their opinion, the corresponding increase in power, and

consequently, engine weight will complicate its deployment on deck. So a specially designed DC linear motor activated by fixed magnets has been envisioned. The plane will be launched by a driving mechanism made of four traction motors and a system of pulleys which pull flexible steel wire ropes. Preliminary calculations show that the length of the launching deck is about 100 m; the weight of the plane, 36 tons; the break-away speed, 85 m/sec; and acceleration g-load, 4.

The foreign press also reports the possibility of using electromagnetic guns as a way of protecting ships (from planes and anti-ship missiles) as well as ground force tank, anti-aircraft, and artillery weapons. Furthermore, at the present time, American specialists are making big efforts to develop space-based electromagnetic guns, which ought to become a component part of wide-scale anti-missile defense with space-based elements built in accordance with the so-called "strategic defense initiative." Even though work in this area is still in the stage of theoretical calculations and experimental research where different kinds of laboratory experiments are being conducted, it is nonetheless witness to the efforts of the U.S. military and political leadership to obtain new-in-principle kinds of weaponry for the purpose of achieving military superiority over the Soviet Union. The position of our state regarding this issue is clearly laid out in the Program of the CPSU, where it is emphasized that the Soviet Union is consistently "striving to limit and constrict the scope of military preparations, particularly those connected with weapons of mass destruction. First and foremost, this scope should fully exclude space, so that it does not become an arena of military rivalry, a source of death and destruction."

COPYRIGHT: "Zarubezhnoye voyennoye obozreniye," 1986

9355

CSO: 1801/216

FOREIGN MILITARY REVIEW

URBAN COMBAT

Moscow ZARUBEZHNOYE VOYENNOYE OBOZRENIYE in Russian No 5, May 86 (Signed to press 11 May 86) pp 23-27

[Article by Col A. Ryzhkov, Candidate of Military Sciences, Docent; "Urban Combat"]

(based on the views of Bundeswehr military specialists)

[Text] The FRG's military and political leadership, in pursuing clearly aggressive aims, is paying considerable attention to increasing the combat might of the Bundeswehr's ground forces. Along with equipping the troops with modern weaponry and combat technology, an important place is being assigned to issues of improving formation and unit combat tactics under special conditions (nighttime, mountain, urban). It is believed that urban combat (in large populated areas) will be an integral component of both offensive as well as defensive operations.

As noted in the foreign press, this comes about because, in the European theater of war (especially in the Central European TVD), large and medium-sized cities are encountered every 10 to 15 km. They are spread out and can significantly affect troop advance. Furthermore, combat in them will be an integral part of conducting a battle (operation) and commanders at all levels will be faced with certain difficulties in organizing combat activity.

Urbanization, in Western specialists' opinion, limits troop mobility, makes conducting a maneuver to concentrate forces on threatened sector more difficult, complicates the control of subunits during a battle, lowers the effectiveness of radio communications and target designation, and limits the field of fire, vision, etc. Furthermore, destroyed urban structures and preserved buildings create favorable conditions for hiding personnel and equipment, particularly in defensive operations, and for creating, from an engineering standpoint, strong points in defended areas and nodes of resistance.

Based on this, Bundeswehr commanders are devoting considerable attention to training troops for operations under these specific conditions. The basic rules for organizing urban combat are reflected in relevant manuals and are widely disseminated in the pages of the West German military press. Specific

questions on tactics are worked out practically in a special training center in Windflenn and in numerous army exercises conducted both according to the national combat training plan as well as within the framework of the NATO bloc.

What are the features of the organization and conduct of combat operations in large populated areas?

West German military specialists believe that during an offensive for some reason or another, a situation can arise where the city (a large populated area) can either be enveloped by troops in order to isolate it or become the object of attack, with its capture achieving the assigned combat mission. All of this will make for a number of special ways to use troops and equipment in attacking the city, which, as a rule, it is recommended, be done quickly. Forward units can be tasked with taking the city on the march, or, if the enemy puts up resistance, they can envelop the city in order to isolate him and prevent him from bringing up reserves. The troops should try energetically to stick to planned sectors, and capturing and fortifying sites within the city boundaries as well as in its suburbs. Tactical airborne assault landings can be launched to assist troop operations in sectors where the primary forces are concentrated or in order to capture important facilities.

Bundeswehr commanders believe that in organizing and conducting an offensive in a large populated area, maximum use should be made of gaps and weak areas in the defense in the approaches to the city as well as of the results of weapons fire damage. It is recommended that strong support points be enveloped and, if it is not possible to neutralize them, to seize and hold those regions of the city which will give the attacker the possibility for building up forces for advancing further.

When a city is located along a major transportation route, and enveloping it is practically impossible, then it is recommended that two force groupings be formed. The first is intended to capture the key positions around the city and isolate it to keep enemy reserves from being brought forward, and from supplying the population and troops defending the city, as well as to prevent the defending troops from retreating. This grouping contains mostly mobile units supported by tactical airborne (air mobile) assault forces.

The second grouping is meant to capture built-up areas of the city and destroy its garrison. It is basically made up of motorized infantry units which include tanks, artillery, and engineering subunits.

In the grouping intended to capture the city (populated area), so-called assault detachments are created from company to battalion in size, that are reinforced with tanks, artillery and engineering subunits. A mandatory element, in West German military specialists' opinion, should be a strong general forces reserve, which is given the task of developing the offensive in the event that the advance of one of the assault detachments is slowed down.

As seen by Bundeswehr commanders, urban combat depends upon the size of the city, its character, and the density of structure. Based on this, a city may fit within the zone of advance of a brigade or division and its seizure may

become the responsibility of one of these units. It is stressed that the width of the zone of advance for a division (brigade) in large populated areas will be somewhat smaller than that under regular field conditions, and the depth of the combat mission will depend upon the character of the operation, the conditions of the situation, and the characteristics of the populated area.

The foreign press reports that during an offensive on a small-sized populated area, the immediate mission of the division (brigade) can be to seize it completely or break out through its opposite perimeter or beyond its limits. In an attack on a large populated area, the immediate mission is to capture one or two cross streets and their attached blocks (for brigades) or to seize three or four streets or a region (for divisions).

The battalion is assigned an immediate mission (objective), such as seizing a block, and a subsequent mission of capturing the next or several blocks. The offensive is generally conducted along one or two main streets along with the attached blocks.

A company can be given the immediate task of capturing a site or several buildings at the beginning of a block and subsequently, the buildings on the opposite side of the block. A platoon has only one objective: a portion of the immediate company objective (two or three small buildings or all of a large building). The combat formations of subunits, units and formations are arranged, as a rule, in two echelons, but if the defending forces do not pose a major threat to the attackers, then they form into one echelon.

West German military specialists stress that specific conditions for conducting combat operations in large populated areas will definitely affect how men and material are employed as well as what types of forces and aviation will be employed. It is believed that in a city, tanks will operate, as a rule, in motorized infantry subunit combat formations, since their mass use will be difficult or completely impossible. Tank subunits and units are intended to be used in full formation to destroy the enemy at the approaches to the city and to envelop from one or two sides for the purpose of sealing him off.

Motorized infantry is given a leading position in the conduct of combat operations. As a rule, it will operate in small subunits which can be supported by fire and engineer support, helicopter fire support, etc. Hence, a motorized infantry company can fight in one or two assault groups. During the fire preparation of the attack, the ordnance and tanks attached to these groups destroy the enemy, and the motorized infantry subunits, using breaks in the walls, underground communications, communications channels and other approaches, move up on the objective and, under fire cover, capture it. If the enemy does not seem to be putting up fierce resistance, then the first echelon subunit moves forward, going after the city's most important facilities. In this instance, the task of the final mop-up of the buildings to rid them of the enemy is allocated to the reserves. It is recommended that underground communications be used to penetrate enemy dispositions and to attack his strong points.

The foreign press reports that decentralized battalion artillery is effectively used to reinforce attacking subunits. For example, a battalion can be supported by a field artillery battalion, a motorized infantry company be a battery, and a platoon by one or more cannon. The enemy is, as a rule, fired upon by direct laying. It is recommended that the artillery assigned to the senior officer be used to destroy large objectives under attack and suppress their garrisons as well as the enemy's artillery and mortars.

Combat engineer subunits usually operate jointly with assault detachments or with the first echelon of the attacking subunits and are used to reconnoiter mines and booby traps, lend aid in deactivating them, do demolition work to make passageways in walls and other obstacles and hindrances, as well as clear out barricades, roadblocks, and rubble. They can use flame throwers to destroy enemy firing points.

Tactical and army aviation are used to destroy objectives, set fires, and suppress troops in facilities being defended. At the beginning of the assault, they strike artillery firing positions and the city's troops, reserves and anti-aircraft defenses, control centers, etc.

Air defense assets are intended to cover attacking forces from air strikes and sealing off the besieged garrison from the air. For this purpose, it is recommended that assets such as the Fliegerfaust air defense missile system be deployed from the roofs of commanding buildings in order to combat enemy aircraft and helicopters. A division's organic air defense artillery regiment can be deployed in squares and parks and to the side of high buildings. During combat operations, it is subsequently moved behind the attacking units.

In order to secure stable communications with the attacking forces, it is desirable that ultra-shortwave radio stations be used, whose antennas, or the stations themselves, may be set up on commanding buildings and other objectives.

During an urban battle, one ought to avoid massing sizeable forces and materials, and after the city is captured, most of the troops are deployed beyond the city limits. Primary attention should be paid to uncovering mines, landmines, etc. as well as preventing and putting out any fires which may have started.

Bundeswehr commanders pay critical attention to the defense of the city, especially when nuclear weapons are not used in combat activities. It is stressed that the defense is organized so as to achieve superiority over the enemy by containing the activities of his main grouping of troops. West German manuals point out that the organization of the defenses of a city or a large populated area, depending upon the conditions of the situation and the assigned tasks, provides for the creation of forward defense area security zones, strong points, nodes of resistances, etc.

Outposts are deployed on approach routes to the populated area (city) in front of the brigade's defensive positions, and several defensive perimeters are set up right on the city lines: in large urban areas, two or three, and in small areas, one.

If it is intended that the city be defended by several divisions, each of them is assigned a zone or sector. The brigade is given a defense region, and the battalion and company, a strongpoint, which can include two or three blocks or several buildings.

In order to create strong points, it is recommended that buildings with half-basements or full basements be used, making it possible to fire upon the attached streets and squares. All these measures prepare an all-round defense with an overhead cover against shelling and observation. Communications routes are built to maneuver small subunits and the walls of buildings are breached. Trenches, slit trenches, emplacements, etc. are dug between buildings, and in courtyards, squares and parks.

Subunit, unit and formation combat formations are usually formed in two echelons with two-thirds of the forces in the first and one-third in the second.

In subunits which take up the defense in multi-storied buildings, fire assets are best echeloned not only in depth but also by story, forming a so-called multi-layered formation to fire simultaneously on the enemy from the upper and lower floors. The majority of fire assets, including detached ordnance, are located in the lower floors of the buildings and in half-basements. It is recommended that buildings which get in the way of fire be removed. Fire positions for these weapons are usually prepared behind fences and walls with embrasures built in them and carefully camouflaged.

West German military specialists believe that in organizing defenses in a city, in order to destroy the enemy effectively, both at the approaches to the city as well as in combatting him on the streets and in squares, a great deal of attention should be devoted to properly deploying organic and assigned fire assets, and to use tanks, helicopters, infantry combat vehicles, and other combat equipment skillfully.

It is believed that tanks assigned to motorized infantry subunits, infantry combat vehicles, and armored transporters are best deployed in fire positions which allow one to shoot by direct laying along streets or along possible enemy attack axes. Field artillery fire, in Bundeswehr commanders' opinion, should be used so that it effectively hits the enemy. In urban combat, it is recommended that ordnance be set up along the probable axes of enemy access. Concentrated fire should be prepared for use on areas where there are probable concentrations of men and material. In all cases it is recommended that the division commander's TO&E contain general support artillery, which can include the 203.2-mm self-propelled battalion howitzer and RSZO IARS.

Substantial concern in the organization of the defense is being devoted to the questions of combatting enemy tanks and other armored targets. Besides tanks, artillery, anti-tank helicopters and engineer obstacle systems (primarily mines), they plan to make wide use of hand-held anti-tank grenade throwers and (self-propelled and portable) ATGM launchers. The Bundeswehr commanders believe that such assets, when properly deployed in the overall system of formation, unit, and subunit defense, will substantially increase the effectiveness of combatting enemy tanks. To do this, they plan to distribute

firing positions on the possible axis where the enemy will appear and to maneuver them around during the course of the battle.

The foreign press reports that the basic missions of army aviation will be to destroy the enemy at the approaches to the city and airlifting subunits and material to threatened axes. In specific instances it can be assigned to inflict fire strikes on areas occupied by the enemy and to mine certain sectors, etc.

The use of other kinds of forces will depend upon the situation and the development of combat activities.

A defensive battle in the city is divided into fighting to maintain the approaches to the city (conducted on the bases of the general tactical situations) and fighting within the city itself (conducted along specific important axes, e.g., roads, crossings, squares, market places, broken down into a number of localized battles). A great deal of attention is being devoted to fighting for individual buildings and facilities and inside buildings, on separate floors, basements, hallways and stairwells.

The defending forces anticipate using mortars for fire support to fire from concealed firing positions close to targets, since buildings in urban-type populated areas can inhibit the use of field artillery. Counterattacks, which assume the nature of assaults on buildings occupied by the enemy, are intended to be conducted along converging axes.

Once the enemy has been penetrated in a key defense region, unit and subunit forces converge to destroy the enemy for the purpose of preventing him from advancing any further. If the first echelon reserve forces do not succeed in liquidating the penetrated enemy, its defeat can be left up to the subunits and units of the second echelon. A battle, in West German military specialists' opinion, can be concluded either with restoring forces back to the lost positions in the city or leaving it.

COPYRIGHT: "Zarubezhnoye voyennoye obozreniye," 1986

9355

CSO: 1801/216

FOREIGN MILITARY REVIEW

U.S. LIGHT INFANTRY DIVISION

Moscow ZARUBEZHNOYE VOYENNOYE OBOZRENIYE in Russian No 5, May 86 (Signed to press 11 May 86) pp 27-30

[Article by Lt Col K. Volodin; "The U.S. Light Infantry Division"]

[Text] The Pentagon allots a prominent place to the ground forces, one of the main branches of the U.S. armed forces, in realizing its militaristic schemes. The foreign press reports that in recent years, they have undergone significant changes. As a basis for their development, a long-range program, ARMY-90 (1981-1990), was begun. In accordance with this program, intensive analyses and practical measures were carried out to develop and put into service qualitatively new weapon systems and military equipment, to improve the organizational structure and to search for the optimum way to employ formations, units and subunits in combat.

In the plan to improve the organizational structure, the American command is paying special attention to the problem of achieving a balance between the so-called heavy and light formations. It is planned to achieve such a correlation of formations of the indicated types in the ground forces' make up that would allow supporting powerful forward groupings and quickly augment them and also, while making use of the high strategic mobility of light divisions, to react to changes in the military-political situation in various regions of the world which the U.S. has declared "zones of its national interests," and to carry out there its aggressive schemes.

In the U.S., ground forces mechanized and armored divisions, intended for conducting high and medium intensity combat operations, primarily in the European theater of combat operations, are referred to as heavy formations, and the light formations are the light infantry divisions being developed, and also airborne and airborne assault divisions.

The light infantry division, in American specialists' estimate, is a qualitatively new type of ground forces combined arms formation. It is intended for rapid airlift and for conducting low intensity combat operations, primarily in weakly defended TVDs under difficult geophysical conditions (the mountains and deserts of Southeast Asia, the forests of Central and South America, Africa and the Pacific Ocean area). They are investigating the problems of employing such divisions in combat in the European theater of war

as well, as a part of U.S. ground forces forward groupings while conducting medium and high intensity combat operations in accordance with the "Air-Land Operation (Battle)" concept.

Organizationally, the light infantry division includes (see diagram): headquarters and HQ company, three brigade staffs and HQ companies, nine infantry battalions, four artillery divisions, an air defense division, an army aviation brigade, three detached divisions (reconnaissance and EW, communications, and engineer), a rear command (headquarters and HQ company, four battalions: repair, transport and supply, medical, and aviation equipment servicing and repair), and a military police company. Overall, in the division (see table) there are 10,768 personnel; 8 155-mm and 54 105-mm towed howitzers; 36 106.7-mm and 54 60-mm mortars; 44 TOW anti-tank guided missile launchers on the M966 vehicle; 162 DRAGON anti-tank guided missile launchers; 8 25-mm automatic cannons; 18 VULCAN self-propelled air defense batteries; 90 STINGRAY air defense missile batteries; 99 helicopters, including 31 reconnaissance, 29 fire support and 36 general purpose; 870 1.25 ton cross-country vehicles; 135 motorcycles and other armaments (1).

According to existing plans, it is intended to have five light infantry divisions in the ground forces (four regular and one in the national guard). The 7th Light Infantry Division has been formed at Fort Ord, California, from the 7th Infantry Division. In the near future, it is planned to create light infantry divisions, with the same composition, from the 25th infantry division (Hawaiian Islands), the previously disbanded 6th infantry division (Fort Richardson, Alaska), the 10th mountain division (Fort Drum, New York), and the 29th National Guard Division (Fort Belvoir, Virginia).

Foreign specialists consider that the main advantage of the light infantry division, compared to an infantry division with the existing organization, is its high strategic and operational-tactical mobility. For instance, to transport it to any point on the globe, will require, by their calculations, not more than 500 flights of C-141B military-transport aircraft (an ordinary division requires 1,450 flights). At the same time, experimental exercises, conducted with 7th Light Infantry Division units and subunits, revealed weak points in its organizational structure, combat employment, and combat support operations. It is also reported that it has a relatively low fire and anti-tank capability, insufficient tactical mobility (only three of the nine infantry battalions can be transported to the perimeter areas of its combat operations by standard helicopters and other transport resources), and a limited capability for conducting combat operations (reserves of material and technical supplies are calculated for 2-3 days). In examining the problems of combat employment of this type of formation in a weakly-defended TVD, the ground forces command considers that when transporting a light infantry division to the area of operational employment, certain difficulties, connected with the problems of positioning military-transport aircraft and their refueling during the flights, including in-flight refueling, can arise, as well as the creation of the necessary supplies of material-technical materials, etc. These and other factors can, in its opinion, reduce a division's capability to build up its strength.

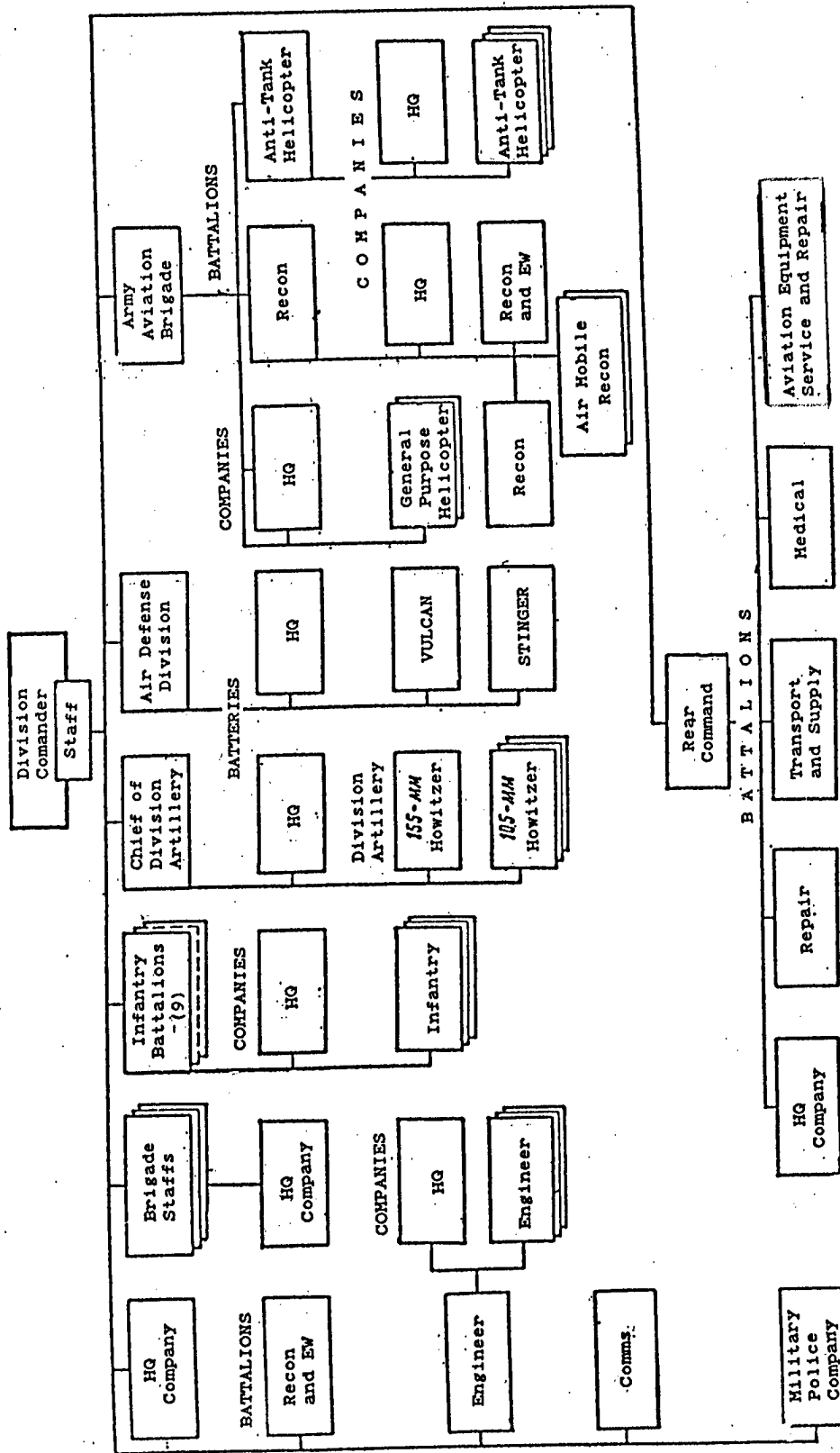

U.S. LIGHT INFANTRY DIVISION PERSONNEL, MAIN ARMAMENT, AND TRANSPORT RESOURCES

PERSONNEL AND ARMAMENT	RECONNAISSANCE										Total	
	DIVISION COMMAND, STAFF AND HQ COMPANY	BRIGADE COMMAND, STAFF AND HQ COMPANY (THREE)	INFANTRY BATTALION (NINE)	DIVISION ARTILLERY	AIR DEFENSE BATTALION	ARMY AVIATION BRIGADE	RECONNAISSANCE AND EW BATTALION	COMMUNICATIONS BATTALION	ENGINEER BATTALION	MILITARY POLICE COMPANY		REAR COMMAND
Personnel	238	105	561	1441	322	1091	313	479	284	77	1161	10768
Towed 155-mm Howitzer				8								8
Towed 105-mm Howitzer				54								54
104.7-mm Mortar on M966 Vehicle			4									30
60-mm Mortar			6									54
25-mm Automatic Cannon on M966 Vehicle						8						8
Anti-Tank Resources:												
TOW ATCM on M966 Vehicle			4			8						44
DRAGON ATCM on M966 Vehicle			18									162
M203 Rocket Grenade Launcher			58									522
Total			80			8						728
M50 Machinegun			18									162
Air Defense Resources:												
Self-Propelled VULCAN Battery	2	1	1	18	18					18		18
STINGER Air Defense Battery	2	1	1	18	58					18		108
Total												
Helicopters:												
Fire Support						29						29
General Purpose						36						36
Reconnaissance						31						31
EW						3						3
Total						99						99
M966 1.25-t Cross Country Vehicle			34	88		110						870
Multipurpose Wheeled and Freight Vehicles and Trailers			15	20		30						616
Motorcycles			15									135

The Pentagon, while developing light divisions mainly as a means for conducting its aggressive policies "from a position of strength," primarily against "third world" countries, is also developing the same kinds of plans for their combat employment in the European theater of war. In the words of the U.S. Army Chief of Staff, General J. Wickham, the light infantry divisions, while possessing high strategic mobility, are capable of reinforcing NATO "forces of containment," at the earliest possible date, in the initial period of an armed conflict in Europe and of providing strategic deployment of the bloc's joint armed forces in accordance with existing plans. Subsequently, in cases when high and medium intensity combat operations are being conducted, their employment will allow increasing significantly the combat capabilities of mechanized and armored formations, particularly when operating under difficult terrain conditions.

The most likely areas of operational deployment of light infantry divisions in the European theater of war, according to foreign press data, could be the northern and southern flanks of NATO joint force groupings where terrain conditions can permit achieving high effectiveness by employing these formations. The most likely areas for deploying light infantry divisions in the Central European TVD are the designated sectors of the mountainous wooded terrain in the operations areas of the 5th and 7th U.S. Army Corps, and also the urbanized zones of the Ruhr industrial region. At the same time, light infantry brigades will be attached to the heavy divisions for subsequent employment on secondary axes and in terrain which hampers the operations of the mechanized and armored formations.

The American command is investigating the basis of combat employment of light infantry divisions as it applies to the "Air-Land Operation (Battle)" concept. Thus, in an offensive, light infantry division units and subunits can be used on secondary axes, and also to execute combat missions to penetrate enemy defenses through sections of almost impassable terrain and to defeat him on the flanks and in the rear. Additionally, they are capable of operating as an air-mobile assault landing force, being landed up to 70 km in the enemy rear for the purpose of destroying or seizing his objectives (in each division there will be 850 trained Rangers).

On the defense, it is intended to employ light infantry division units and subunits mainly on secondary axes, for conducting combat operations in built up areas, forest and mountainous tracts, and in swampy terrain.

Much attention is being paid to the development of ways to use these divisions in coordinated actions with mechanized and armored subunits, and also with fire support helicopters when executing combat missions for the protection and defense of rear areas. It is considered that joint employment of forces and resources of heavy and light formations will yield the greatest effect during operations against enemy airborne and air mobile assault landing forces, maneuver groups' armored and mechanized infantry units and subunits operating in division and army corps rear areas.

In the case of combat employment of a light infantry division on independent axes as part of NATO joint forces, they can be reinforced with up to three independent brigades (mechanized or armored, field artillery, and army

aviation). Additionally, it is intended to include light infantry divisions in the make up of operational or strategic reserves of army corps, army groups or NATO joint forces in the European Theater of war.

The American command believes the presence of light infantry divisions in the composition of the ground forces can provide the country's military-political leadership with a highly mobile contingent of forces for rapidly transferring them to any point on the globe for the purpose of carrying out their assigned missions.

1. According to the latest foreign press information, there is a 155-mm howitzer battery (division in the text), and also an aircraft equipment service and repair company (battalion in the text).--Ed.

COPYRIGHT: "Zarubezhnoye voyennoye obozreniye," 1986

9355

CSO: 1801/216

FOREIGN MILITARY REVIEW

COMMAND AND CONTROL OF U.S. AIR FORCES

Moscow ZARUBEZHNOYE VOYENNOYE OBOZRENIYE in Russian No 5, May 86 (Signed to press 11 May 86) pp 38-41

[Article by Col V. Tamanskiy, Candidate of Technical Sciences, Col V. Grebeshkov; "Command and Control of U.S. Air Forces"]

[Text] THE DEVELOPMENT OF THE U.S. AIR FORCE COMMAND AND CONTROL SYSTEM Presently, while the aggressive imperialistic forces are actively pursuing a policy of inflating the arms race and further complicating the international situation, the U.S. military leadership is carrying out a number of programs to build-up the combat power of the armed forces. At the same time, a program for improving the country's armed forces control system forces and its subsequent development, including the air force, is at the center of attention. American military specialists note the following main trends in solving the given task: an increase in control effectiveness, stability, flexibility and security.

The problem of increasing the stability of the air force's control system acquired special urgency when the U.S. military-political leadership adopted the "direct confrontation" strategy. The idea of conducting a lengthy war using nuclear weapons is openly being proposed for the first time in it, so that it is impossible not to influence the development of the armed forces. With regard to the control system, it became apparent in that, in accordance with the command's requirements, it must operate continuously under normal peacetime conditions, during a preparation period for the unleashing and conduct of a lengthy war using nuclear weapons. Actually the question concerns a system that must be able to function after the delivery of retaliatory nuclear strikes by the opposite side. This, according to American expert opinion, can be achieved only with a significant increase in its survivability. The attempt to insure the control system's effective functioning during enemy radio-electronic jamming led to the emergence of another part of the requirement, the increase in its jam-resistance. In addition, control stability depends on its reliability.

As foreign press pages note, the rational combining of fixed and mobile control posts and the integrated use of various communication systems for the mutual exchange of information between them is the main method of increasing the survivability of the air force's control system. This is explained by the

fact that, with the emergence of highly accurate nuclear missiles, existing underground protected fixed command posts ceased to satisfy the requirements for survivability, and now belong to the class of targets which can be put out of commission at the beginning of a nuclear missile war. To strike mobile control posts, not having permanent coordinates, is much more complicated. Therefore, their use at strategic and operational-tactical levels substantially increases the survivability of the air force's control system.

Airborne command posts, placed at the disposal of the Joint Chiefs of Staff (four E-4 aircraft), the SAC commander (approximately 30 EC-135 aircraft, including the ACPs, airborne command posts for ICBM launches and relay aircraft), the commanders of the U.S. Armed Forces Unified Commands in the European zone, and the Atlantic and Pacific Oceans (EC-135) have received the greatest development at the strategic level in the U.S. As a rule, technical communications units and data processing and display systems are deployed on airborne command posts, allowing the task of controlling subordinate forces to be executed during a flight along a given flight route. As the foreign press notes, the emergence of mobile ground command posts at the strategic level is possible along with airborne ones.

Mobile ground command posts, developed on the basis of special vehicles, in which the necessary complex of technical data processing, display and transmission equipment is installed, are the most widely deployed at the operational-tactical level. At the same time, the use of airborne command posts, such as the EC-130 and E-3 are being planned for use at this level.

Judging by American press materials, the U.S. Air Force command is paying special attention to the issues of increasing the survivability of communications since, during the employment of nuclear missiles, antenna systems can be put out of commission primarily by the shock wave. In order to reduce the latter to a minimum, command posts are connected with one another by various types of communications systems, including satellite communications. During the course of the work to increase the survivability of the air force's control system, the Pentagon intends to deploy and use state-of-the-art communications systems for both strategic and operational-tactical level control organs.

The achievement of a higher jam-resistance control system is provided by carrying out a series of organizational and technical measures. The technical measures pursue the goal of developing and equipping the air force with control systems which possess increased jam-resistance, and organizationally the development of a structure which provides the most effective use of these systems.

As foreign press materials note, high control reliability can be achieved by the following means: by equipping control posts with technical information processing, display and transmission equipment developed using state-of-the-art microelectronics; by making (duplicating) the most important elements and nodes redundant; by integrating the use of land-line and radio communications operating in various bands of the electromagnetic spectrum, from very long [VLF] waves to millimeter waves; by further developing and combining the use of

technical reconnaissance systems as important sources of information about the enemy.

It is emphasized, that state-of-the-art microelectronics, of which integral micro systems comprise the basis, allow reconnaissance and information processing, display and transmission systems to be developed having an average mean time between failures of 10,000 hours and an improved average restoration time, not exceeding 15-30 minutes. This insures that the radioelectronic equipment's correct coefficient of operations approaches 1.

In practice, the redundancy (duplication) of the most important elements and nodes in the control system is the traditional and most widely used method of increasing control reliability. This method allows the required (assigned) reliability to be achieved even with the existence separate elements, junctions and control system equipment which are highly imperfect from the standpoint of reliability.

As the Western press notes, the integrated use of communications systems, allows the reliability of communications between control points in various situations to be significantly increased even during the employment of nuclear weapons. At a strategic U.S. Air Force control level, the main efforts are being directed at increasing the reliability of the following communications links: the JCS, the SAC commander, ICBM launch control posts and strategic aviation aircraft. Within this plan, a great deal of attention is being paid to implementing programs to improve and develop new satellite and long-wave (super long wave) communication subsystems.

According to foreign press reports, currently a terminal operating in the 225-400 MHz range, is most widely used on the Air Force's AFSATCOM satellite communication system. In the near term plans, with the commissioning of the Department of Defense satellite communications subsystem it is planned to install AFSATCOM system relays along with the DSCS-2 equipment being used, which operates in the 7-8 GHz band. In a more distant prospect, it is planned to adopt the new MILSTAR satellite communication system, transferring operations to the 20-44 GHz range. According to American specialists' opinions, due to the use of noise-based signals (which have a wide band width for transmitting transceiver paths) and the increase in the gain coefficient of antennas and their directivity, not only is communication reliability increased, but also its jam-resistance. The American press notes that there are two programs in the realm of long-wave communications; the development of a new GWEN communications subsystem and the equipping of strategic bombers with small-sized long wave band receivers.

The GWEN communications subsystem will operate in the long-wave band of the electromagnetic spectrum (150-175 kHz). It is designed for sending commands for ICBM launches and the take-off of strategic aircraft by using long-wave band frequencies' propagation phenomenon of a surface (ground) wave. Commercial and military (air force) long-wave communications transmitting centers, deployed on U.S. territory, will comprise the basis of the subsystem. It is planned for it to become operational in 1990.

The equipping of strategic bombers with small-sized long-wave band receivers will increase the reliability of sending commands to strategic aircraft in the air. The beginning of series production of such receivers is planned for 1987.

As it was mentioned above, the main efforts on the operational-tactical level are being directed at providing reliable communications in nets: the air force's large force commander, the commander of an air force unit (subunit), and the air crews and between them on the ground and in the air. Improving the communications systems at this level is being accomplished through several programs: HAVE CLEAR, HAVE QUICK, SINGARS and JTIDS.

The HAVE CLEAR program, for which approximately 3 billion dollars was allocated to implement, envisions developing and equipping the air force with jam-resistant communications systems which must simultaneously conform to requirements, and be compatible with the communication and information distribution system being developed under the JTIDS program.

According to the HAVE QUICK program (approximately 100 million dollars has been allocated for it), firms are busy developing and equipping the air force with AN/ARC-164 modernized radios for installation in aircraft (around 7,000 radios have been purchased) and on the ground (5,000). The SINGARS program is aimed at developing a ground and aircraft ultrashort frequency range system, operating in the 30-300 MHz range, but the manufacturing cost for its communications systems is exceeding 100 million dollars.

In solving the task of increasing the U.S. Air Force command's control reliability, a great deal of attention is being paid to the development of reconnaissance systems and resources, which is reflected in corresponding programs. In particular, the foreign press mentions the programs to improve the missile strike warning systems: IMEWS, BMEWS and PAVE PAWS; space monitoring systems; air target detection systems; and also aerial and space reconnaissance systems. At the operational-tactical level, the main attention is being paid to programs for the development of technical reconnaissance systems and reconnaissance information processing and distribution centers.

Along with improving the equipment for solving the task of improving control reliability, the Air Force command is carrying out organizational measures, establishing the order and operational rules for official personnel, and the use of command posts and control systems.

As the foreign press notes, the air force's high control effectiveness can be achieved by widely using, within the framework of a single plan at the strategic and operational-tactical levels, those processing resources for displaying and transmitting data, which comprise the basis of an automated control system. In connection with the fact, that the control of the air force is carried out not only by its own, but higher existing control organs, the solution to the problem of increasing control effectiveness is tied in with the improvement and development of automated systems, with which the air force control posts, the U.S. Armed Forces, and above all the JCS and CINCs of the Unified Commands are being equipped.

As the foreign press reports, presently the following are being equipped with automated systems: JCS (ACS NMCS) ground control posts and its airborne command posts; the ground control posts of the Secretary of the Air Force and staff (ACS 473L), the Specified Commands CINCs (for example, SAC, ACS 465L; AFSPACECOM, ACS 427M, etc.), and the CINCs of the U.S. Armed Forces Unified Commands; the airborne command posts of the U.S. Armed Forces Unified Command CINCs in the European areas, the Pacific and Atlantic Oceans, and CINC SAC. Technical automated systems are being used at the operational-tactical level within the framework of the 485L ACS for tactical aviation combat operations.

Judging by American press materials, the main efforts for solving the problem connected with increasing control effectiveness are being focused on improving existing and developing new technical automated systems for mobile control posts, above all, airborne command posts. In particular, in 1984, the air force command concluded a contract for the modernization of 39 EC-135 aircraft. The program will extend over a seven-year period and cost approximately 200 million dollars. At the same time, attention is being focused on further developing the technical automated systems located at ground control posts. The program to develop a new ACS for the Military Airlift Command testifies to this. According to American specialists' opinions, it will allow all the necessary initial information to be sent to MAC during preparation for execution no later than one minute after an inquiry.

A program to further improve the 485L ACS is intended for the operational-tactical level. It is directed at reducing the time for delivering assigned orders to subordinate forces and at expanding its capabilities for the correlated processing of received information, its accumulation and timely representation.

For solving the problem connected with increasing control flexibility, the Air Force command is first trying to implement a control system capability which more fully responds to a situation change. In this regard, it is focusing the main attention on achieving harmonious unity and continuity of the control structure for operations in the usual peacetime environment, during preparation for the beginning of military operations and during a war, including the use of nuclear weapons.

In trying to increase control security, the U.S. Air Force command is pursuing the goal of keeping the planned measures and operations of the control organs and subordinate forces a secret from the enemy. Since the air force control system is comprised of technical control systems, above all radioelectronic ones, then the most important issues concerning the achievement of security is solved by the security and radioelectronic warfare command (Electronic Security Command). It conducts an entire aggregate of special and technical measures, in particular the monitoring of technical information transmission systems operations, the monitoring of the conformance to established rules and radio exchange modes, and the use of secure communication channel systems, etc.

Thus, within the general aggregate of measures to increase the air force's combat power, the U.S. Armed Forces command assigns an important place to the

development of an air force control system, which corresponds to modern requirements and is capable of carrying out its functions in various conditions, including during the conduct of a lengthy war with the use of nuclear weapons.

COPYRIGHT: "Zarubezhnoye voyennoye obozreniye," 1986

9355

CSO: 1801/216

U.S. OVERHEAD RECONNAISSANCE EQUIPMENT

Moscow ZARUBEZHNOYE VOYENNOYE OBOZRENIYE in Russian No 5, May 86 (Signed to press 11 May 86) pp 41-45

[Article by Col N. Gabrilov, Candidate of Military Sciences; "U.S. Overhead Reconnaissance Equipment"]

[Text] Landscape reconnaissance systems have been widely developed among the various types of American space reconnaissance systems. (1) Their special-purpose equipment represents the integration of observation information collection and recording units for subsequent transmission to their consumers. Judging by foreign press reports, the development of this system has proceeded in the direction of expanding the band of the electromagnetic spectrum, in which observations are conducted, and the introduction of information collection systems, operating on new physical principles. Currently observation systems are being used, which function in both the optical band and in the radio frequency band. Electro-optical systems in the form of scanning radiometers with linear matrices are among the optical wave band systems being developed which have been deployed along with aerial cameras (AFAs). In addition, direct viewing systems with linear matrices are being developed. Limited use of traditional television observation systems continues. Microwave radiometers are used in the radio frequency band, and synthetic aperture radars are also being improved. The potential to equip spacecraft with systems, operating on the scattermeter principle (bistatic radars and correspondingly, scattermeters), is being investigated.

Information on special-purpose landscape reconnaissance systems, installed on American spacecraft, and their development is presented below.

In essence, by the middle of the 1970s, aerial cameras were the main means of observation from reconnaissance spacecraft in the U.S. Achievements in the realm of long-focal AFAs, having a linear resolution of approximately 40 lines/mm, were the basis of their development. The subsequent development of photo systems proceeded in the direction of improving the entire landscape information receiving process, beginning with the adoption of indirect measures to increase the contrast of reconnaissance targets by introducing spectrozonal and zonal photography, and ending with the development of image processing and analysis systems. However, as the Western press notes, camera lenses and photographic film were open to significant improvement.

Linear lenses with a focal length on the order of 1-2 m were used on the first types of space cameras, which were intended for conducting survey reconnaissance. Their resolution was almost up to the theoretical limit (up to 90 per cent) due to the introduction of machine analysis methods, the improvement in design and the manufacturing technology of individual design elements, and the introduction of compensation devices. For example, the development of a lens for a high altitude camera with an field-of-view angle of 1 degree was reported. Its linear resolution on the 0.5 micrometer (mkm) wave length was 450 lines/mm (the resolution diffraction limit at this wave length is 500 lines/mm), and the entire "film-optic" system was 180 lines/mm. For the medium-length focal series of lenses on space cameras, a resolution of 110-135 lines/mm was achieved.

To improve the lenses, it was considered important to switch to reflective designs with a large focal length. The first reflective lenses with a focal length of 1-6 m appeared at the end of the 1970s, and in that same period, work commenced on the development of lenses with a focal length of 18-20 m. Presently, four main configurations are the most widely deployed in the design of reflective lenses: Cassegrain, Schmidt, Schmidt-Cassegrain, and a composite catadioptric lens. In Cassegrain-designed lenses the primary mirror is parabolic and the secondary mirror has a hyperbolic configuration. They are distinguished by a small aperture ratio and a small field-of-view angle (up to 2 degrees). Narrow films (most often with a width of 70 mm) are used in cameras with such lenses. The lenses, developed on the Cassegrain design, are the most compact of all existing designs. In practice, reflective elements are usually combined with linear designs, forming the so-called catadioptric (linear-reflective) lenses. As a whole, Cassegrain-type lenses are used in spectrozonal systems, since they do not produce spherical aberrations.(2)

Schmidt lenses have a spherical mirror and a correction plate which extends forward (Fig. 1). Large field-of-view angles (up to 10 degrees) and aperture ratios are considered to be the merits of such lenses. They are free from spot (3) and astigmatic (4) type distortions, and easily permit their elimination using special correction devices. At the same time, lenses of this type possess a spherical aberration and have large dimensions (the length is almost twice the focal length). In particular, a space telescope for the early launch detection of ballistic missiles was developed using the Schmidt design.

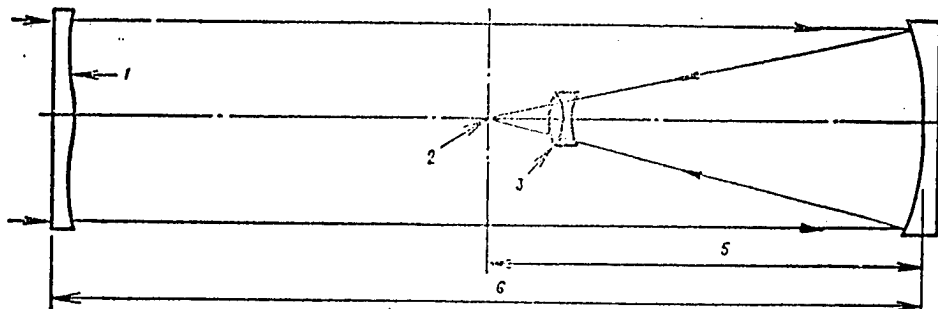

Figure 1. Schmidt Lens Schematic.

1. Corrective plate; 2. Focal plane; 3. Corrector focal plane;
4. Primary mirror; 5. Focal Distance; 6. Overall length (two focal lengths).

In Schmidt-Cassegrain type lenses, the primary mirror is spherical or parabolic. They have an optimum aperture ratio and comparatively large field-of-view angles. American experts consider it possible to develop lenses with a field-of-view angle of more than 4 degrees for photo systems, employed for photography at an altitude of approximately 150 km, and to use 13-cm wide film.

Catadioptric (linear-mirror) lenses are used both in photographic, and in electro-optical systems. They have a comparatively large field-of-view angle, inherent with a linear lens, and a significant focal length. The presence of aspherical elements in their design is a deficiency of catadioptric lenses, and from an optic-mechanical view point, these lenses are significantly more complicated than linear lenses.

The relatively light weight and small dimensions (besides the lenses, operating on the Schmidt principle) are considered to be important merits of reflective lenses, developed according to the schematic mentioned above. For example, the weight and length of catadioptric lenses with a focal length of 1.6-1.8 m are almost 5 and 3 times less, respectively, than with similar linear lenses. As a result, the static linear resolution of a reflective lens is 30 per cent greater. The comparative characteristics of representative types of reflective and linear lenses are presented in Table 1.

TABLE 1
COMPARATIVE CHARACTERISTICS OF REPRESENTATIVE TYPES OF
REFLECTIVE AND LINEAR LENSES

CHARACTERISTICS	REFLECTIVE LENS	LINEAR LENS
Total length, (mm)	792	2,108
Focal length (mm)	1,829	1,676
Aperture opening diameter (mm)	495	419
Aperture opening surface (mm)	1,541	1,280
Aperture ratio	4.7	4
Field-of-view (deg)	2	6
Glass component weight (kg)	38.1	122.5
Total lens weight (kg)	136	363
Static linear resolution, lines/mm (film 3414, contrast 2:1, W-12 filter)	170	120
Static angular resolution (mrad)	3.2	5

The foreign press notes, that the introduction of scanning systems with a wide spectral wave band into reconnaissance equipment makes the development of reflective optics possible, since reflective lenses do not introduce chromatic

aberrations.(5) Correction devices for geometric distortions, resulting from the inaccuracy in the filling-out of the mirror shape, are also relatively easy to use in them. Depending upon the required degree of correction, mirrors can have either a comparatively simple spherical design or a complex higher-order spherical shape. In the future as U.S. calculations indicate, the improvement in reflective optics, which in particular is connected with an increase in the orbital observation altitude (up to a stationary orbit), will lead to the use of lenses with a focal length on the order of tens of meters and with a mirror diameter on the order of several meters. It is reported, that the use of light-weight modular-designed mirrors and mirrors with a guided deformity of their surface will characterize such lenses. They think that distortions in them, connected with mechanical and temperature factors, will be able to be eliminated in real-time. Special adaptive devices (adaptive optics), capable of partially compensating for turbulent disturbances and eliminating the detrimental effects of other factors, reducing the resolution of optics, are being developed for large-sized modular-designed lenses.

According to foreign press reports, the film used in space cameras, and their improvement appears to be following advantageously in three directions: the speed is being increased without increasing (and sometimes even reducing) the grain size; special so-called "anti-camouflage" films are being developed; IR film, intended for the photography of small-contrast targets and for operating at low light levels are being improved. Presently more than 25 types of film for air and space reconnaissance, covering the frequency band from 0.3-0.9 mkm, is widely used and being developed in the U.S. According to American specialists' opinions, the film characteristics have reached their maximum values. Thus, superhigh resolution film has a resolution of 800-840 lines/mm with a contrast of 1,000:1 and 250-280 lines/mm with a contrast of 2:1. High speed panoramic films have the same contrast values with a resolution of 200 lines/mm, and IR and special spectrozonal films (with a output image in light conditions)-- up to 70 lines/mm (Table 2).

TABLE 2
CHARACTERISTICS OF SEVERAL U.S. FILMS
USED IN SPACECRAFT

FILM DESIGNATION	SPECTRAL BAND (MKM)	GRAIN INDICATOR	RESOLUTION LINES/MM			
			W	I	T	H
	CONTRASTS		1.6:1	1000:1		
2376	.	.	63	160		
3410	.	13	80	250		
3412	up to 0.7	9	125	400		
3414	.	8	250	800		
5069-5460	.	.	180	600		
SO-115	.	.	115	255		
SO-415	.	.	441	830		

It is considered that in spite of the trend to replace aerial photography systems with electro-optical systems in space reconnaissance, the use of film has a number of advantages. In particular, systems with the image displayed on film provide a greater order of information than similar non-film optical systems, and the dynamic resolution characteristics for film displays of equivalent size are two times better, than with "vidicon" type television tubes and photodiode matrices.

As a whole, U.S. experts note the following merits of photographic systems: high spacial resolution, the metric accuracy and informativeness, the relative ease and rapid deciphering of the collected information, the relatively small cost, the compactness of the information recorder, reconnaissance documentation for repeated use and also the longevity of the saved information. At the same time, they have characteristic deficiencies such as the necessity to obtain information when there is a break in the cloud cover and slight illumination of the earth's surface, the delay in the delivery of information to the consumer, the relative complexity of the device converting the image into electromagnetic signals.

Electro-optical systems, which have already been used on the KH-11 and LANDSAT satellites, have been widely developed as reconnaissance systems for the past 7-10 years in the U.S. They are different from film systems in that electro-optical systems have a collection of lines or mosaic matrices or photoelements in the focal plane. The comparative ease of conducting spectrozonal observations, including in many parts of the IR spectrum, is a characteristic feature of electro-optical systems. It allows objects to be easily distinguished against the terrain background, camouflage to be revealed and supplementary information on the reconnoitered target to be obtained.

The use of instrument display units with a charge couple and a digital read-out system, and a real-time data image transition system are other features of electro-optical observation systems. This promotes the wide introduction of computers in such systems for forming and correcting the images received on the ground. According to Western press reports, algorithms for forming images are being developed and used in the U.S., which simultaneously provide the capability to correct geometric distortions and to a great extent, to increase the contrast, to enhance the definition of target outlines and also to compensate for distortion caused by the atmosphere.

According to American military experts' opinions, the introduction of machine methods for forming images allows limitations, imposed by the atmosphere on the resolution of photographic systems, to be reduced. It is reported in particular, that images from the LANDSAT satellite, received using a low resolution spectrozonal system, provides the same volume of information as high resolution images. As U.S. experts believe, in the future, the development of optical observation systems will follow the course of perfecting electro-optical systems, spectral reconnaissance methods, digital systems for transmitting information to the ground and their machine processing by computer.

Side-looking synthetic aperture radars are considered to be an important type of landscape reconnaissance system, although they are not widely employed. The prototypes of such radars are currently undergoing an experimental check and trials under natural conditions for the purpose of assessing their effectiveness as an all-weather reconnaissance system in naval or ground TVDs.

The foreign press notes that two radars have already been tested; the SAR (on the SEASAT satellite) and the SIR-A (on the space Shuttle). During their assessment, the information from the images, received using these radars, was compared both between them, and with the images on photographs from the LANDSAT satellite. Analysis of the images showed, that each of the studied photographs contained additional information characteristic only to them, but that the information of the images from both radars in observing terrain relief and the ocean surface were the same, in spite of the two-fold difference in their resolution. It was reported that the SIR-A radar had an increased resolution due to the use of a large polar diagram inclination angle. The comparative characteristics of these radars are presented in Table 3.

TABLE 3.

COMPARATIVE CHARACTERISTICS OF THE SIR-A AND SAR RADARS

CHARACTERISTICS	SIR	SAR
Employment altitude (km)	260	795
Carrier frequency (MHz)	1278	1275
Impulse length (mks)	30.4	33.4
Return impulse frequency (GHz)	1464-1824	1463-1640
Bandwidth (MHz)	6	19
Transmitter impulse power (kWt)	1	1
Antenna dimensions (m)	9.4 x 2.16	10.7 x 2.16
Polar diagram incidence angle (deg)	50	23
Terrain resolution (m)	40 x 40	25 x 25
Observation data recording method	in orbit, optical	on the ground in digital form

The field-of-view width of modern side-viewing radars reaches 100-125 km. U.S. specialists believe that radars with a field-of-view width up to 250 km and a resolution of several meters can be developed by 1990. The development of wide-band and multi-channel radars, operating with various polarization combinations of the radiated and received signals, is considered to be the future direction in the development of reconnaissance radars. Currently, mainly radars in the decimetric wave band are being investigated for reconnaissance purposes.

Judging by foreign press reports, the capability to operate in various modes is a characteristic design feature of several experimental space-based radars: scattermeters (non-coherent radars) and microwave radiometers (passive

radars). It is planned to use separated (bistatic) radars, in which the terrain illumination device and the receiver for the reflected signals are installed on various objects (for example, the transmitter on one spacecraft and the receiver on another, or on an aircraft). It is considered, that a similar design principle for a reconnaissance system reduces its vulnerability and increases its jam-resistance.

As the Western press notes, work on the "Star Wars" program, the ominous plans of the present U.S. administration to militarize space and transform it into a new zone of combat operations in which an important role is played by space reconnaissance systems, is exerting a large influence on the subsequent near-term development of reconnaissance equipment on spacecraft. According to the NASA LUNETTA program, it is planned to launch light-weight constructed mirrors, having a diameter of 100 m, into stationary orbit. Each such mirror can reflect the sun's energy on a surface having a diameter of 350 km, creating an illumination on it greater than a half moon. Although this project was created for illuminating towns and highways, nevertheless it is considered that the developed systems can be used for conducting night time reconnaissance. For the reconnaissance of natural resources, it is planned to use a space-based antenna system several hundred meters in size, which can receive images in the radio band with a terrain resolution better than 1 m.

The development of large-size, small-mass optical systems for observation from a stationary orbit is being carried out within the framework of the Defense Department's HALO (High Altitude Large Optics) program. Accordingly, it is planned to develop so-called light-weight constructed adaptive optical devices (mirrors), matrix devices with $10^6 - 10^7$ elements, onboard processors, controlled filters and cryogenic techniques.

A multipurpose space-based radar is being developed by Grumman for the purpose of developing a universal radar for detecting combat aircraft, ships, and cruise and ballistic missiles from space. Several possible radar variants are being considered. One of them envisions the use of antennas formed out of light-weight, thin materials with another based on the use of a modular-type antenna grill, where each antenna element is formed from an integral miniature transceiver. According to U.S. specialists' opinions, such radars will be able to detect small-sized targets (tanks and small-displacement ships) from orbit (2,000-10,000 km altitude) and also to conduct thorough engineering reconnaissance of the terrain.

1. For greater detail on space reconnaissance systems see: ZARUBEZHNOYE VOYENNOYE OBOZRENIYE, No. 11, 1984, pp. 55-58.

2. A spherical aberration is a distortion of the image, occurring when the image of the point, lying on the system's main optical axis, has a type of circular scattering.

3. A spot is a distortion of the image. It occurs with the passage of wide light beams through the optical system from the points of an object, located some distance from the system's main optical axis. The image of these points has a type of extending and non-isochronous illuminated spot.

4. An astigmatism is a distortion of the image, existing when the image of an illuminated point, in general has a type of elliptically shaped spot, which on several positions of the image plane, degenerates into a direct sector or circle.

5. A chromatic aberration is a defect in the optical system connected with the dependence of the transparency medium's refractive index on the length of the light wave. As a result of a chromatic aberration, the image is washed out and its edge is blurred.

COPYRIGHT: "Zarubezhnoye voyennoye obozreniye," 1986

9355

CSO: 1801/216

FOREIGN MILITARY REVIEW

FEDERAL REPUBLIC OF GERMANY NAVY (FRGN)

Moscow ZARUBEZHNOYE VOYENNOYE OBOZRENIYE in Russian No 5, May 86 (Signed to press 11 May 86) pp 47-55

[Article by Capt 2nd Rank Yu. Kravchenko; "The FRG Navy"]

[Text] The establishment of the Bundesmarine (FRGN), just as the establishment of the country's armed forces in general, was a consequence of the aggressive policies of international imperialism headed by the United States. As early as January, 1951, the first talks concerning the re-establishment of West German naval forces were held between Chancellor Adenauer and General Eisenhower.

The 1954 Paris accords and the formation of NATO (May 9, 1955), opened a direct course for the growth of the FRGN, which by the end of 1960 numbered 23,800 personnel. The accords permitted the construction in the FRG of submarines no larger than 350 tons and surface ships up to 3,000 tons.(1) The NATO nations furnished considerable assistance to the newly-founded FRGN by transferring ships, naval bases and basing points, as well as repair facilities. From its very inception, the objective of the FRGN was a close working relationship with its partners in the aggressive NATO bloc.

The politico-military leadership in NATO, planning for future wartime operations, recognizes the important strategic position of the FRG. Foreign defense specialists consider that the Baltic straits and adjoining regions are crucial positions in NW Europe. From the beginning of the war the North Sea and the Baltic approaches will become an important location to gather to meet convoys of reinforcing troops, arms, combat assets and war supply materials arriving in Europe from the U.S. and Great Britain. In addition, these waters link, via the shortest route, the FRG, Norway, Denmark, the Netherlands and Belgium and the disruption of these SLOCs can directly impact adversely on the economic condition of the NATO nations, and can hinder movement of forces and resources between Central and North European theaters of operations. These circumstances lay behind the concept of employing the FRGN in any future war, according to which, their fundamental assignment will be maintaining, in conjunction with other bloc navies, a satisfactory operational condition in this very important NATO region.

In conjunction with the basic mission of the FRGN, execution of the following essential combat problems has been assigned to them: in the southern portion

of the Baltic Sea and the Strait zone, blockade the Baltic Strait, combat enemy naval forces, destruction of its sealift, operations jointly with the littoral flank of the ground forces, participation in seaborne amphibious operations, counter-mine and counter-amphibious missions along the FRG coast (Schleswig-Holstein area), Denmark, and Southern Norway; in the North and Norwegian Seas, protection of SLOCs, combat enemy naval forces, destroy his transit shipping, feeding forces opposing the combined NATO forces in Europe and defending the coastal areas of the bloc countries from attack from the sea.

In the FRGN high command's view, the country must have a quantitatively balanced fleet and naval aviation capable of flexible execution of assigned missions in areas with different operational situations. In the central and northern Baltic, where enemy counteraction is expected to be heavy, the use of submarines and fighter-bombers is proposed. Strike groups of missile boats, in cooperation with naval air, form the basis of their strength in the straits and approaches, along with mine sweepers and minelayers; and in the North and Norwegian Seas there are destroyers, frigates, submarines, mine force ships, fighter-bombers and land based patrol aircraft.

Ship construction and operational readiness of the FRGN is in strict conformity with their primary mission, combat capabilities and areas of operational assignment. In peace time they are under national subordination, while, at the outset of war or in exercises, they transfer to the joint NATO naval command in the Baltic Strait zone.

ORGANIZATION AND COMBAT COMPOSITION. The organizational structure of the FRGN calls for the establishment of type commands and units according to ship classes and type of forces; assigns its basing, daily activities, combat readiness, personnel recruitment, maintenance and repair. Basically, it consists of flotillas of combat ships and vessels (destroyers, submarines, missile boats, mine forces and supply ships as well as divisions of Naval Aviation).

During wartime and in training periods, conducted both in a national framework and as part of joint NATO naval forces, it is planned to form up operational commands and groups for action in the Baltic and North Sea.

According to JANES, at the beginning of 1986, the FRGN numbered about 300 combatants, craft and auxiliaries as follows: 24 diesel submarines, 7 guided missile destroyers, 6 guided missile frigates, 3 frigates, 6 corvettes (2) (small ASW ships), 40 missile and 50 landing ships and craft (30 in the reserves, and 1 used as a trainer), 59 mine vessels (including 2 mine supply ships) more than 130 auxiliary support ships and craft, and about 190 aircraft and helicopters. Technical characteristics of warships and combat craft are displayed in the table.

Naval forces, comprising the fleet and aviation, are commanded by a Naval Inspector (CINC) who commands via a main staff in Bonn. Organizationally the Bundesmarine includes the fleet commands and Naval support, as well as the central naval directorate (see Fig. 1)

Fleet Command, (HQ in Glucksburg, Schleswig-Holstein) combines fleet type commands (combatants and support ships), Naval aviation, communications detachments, scientific research group and various shorebased services. The Fleet CINC is responsible for combat readiness, operational and combat training of assigned units and detachments, and organizes their daily activities. A direct subordinate is the commander-in-Chief, North Sea (based at Wilhelmshaven), who does not have any permanent forces or staff assigned (he receives them during training periods).

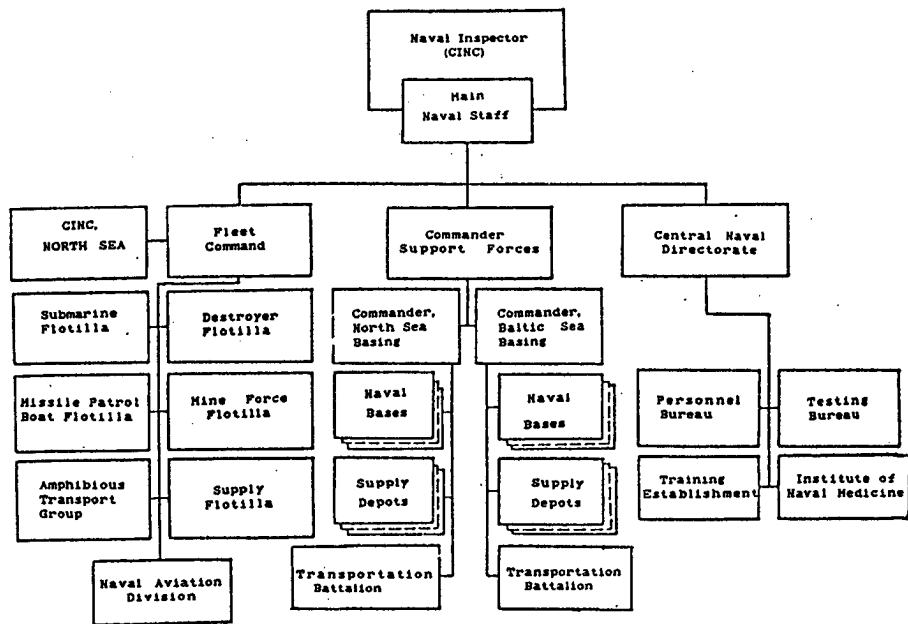

Figure 1. FRG Navy Organizational Structure

Under the CINC's command, according to the foreign press, are five flotillas (submarines, destroyers, missile boats, mine forces and supply), an amphibious group, a naval aviation division, as well as a communications and radio-electronic command and a tactical training group.

The submarine flotilla (based at Kiel) is made up of two squadrons and a training detachment of underwater operations (Neustadt). In the 1st squadron at Kiel there are 6 Project 205 submarines, as many Project 206 types and the A55 tender LAN; in the 3rd (Ekkernfiord) there are 12 Project 206 types and the A56 tender LEX. In foreign defense specialists' judgement, submarines of

TECHNICAL CHARACTERISTICS OF SHIPS AND CRAFT
OF THE FRG NAVY

Ship type - Number in commission (side # and name) Year entered fleet	<u>Std displ (t)</u> Full displ	Primary dim- ensions (m) length beam draft	Power (hp) Max speed (kt)	Crew size (Officers)	Armament ¹	Range at speed
--	------------------------------------	--	------------------------------	-------------------------	-----------------------	-------------------

SUBMARINES

TYPE 206 - 18 (S170-179, 192-199) (1973-1975)	<u>498²</u> 550	43.9 4.6 4.3	<u>1500 1800³</u> 10 17	22 (4)	533-mm torp tube (8) torp/mines	<u>4500 200³</u> 5 4
TYPE 205 - 6 S180, 181, 188-191, FRG, 1966-69	<u>370</u> 450	43.9 4.6 4.1	<u>1200 1500</u> 10 17	22 (4)	"	<u>4200 200</u> 5 4

GUIDED MISSILE DESTROYERS

LUTJENS - 3 D185 LUTJENS D186 MOLDERS D187 ROMMEL 1969 - 70	<u>3700</u> 4500	133.2 14.3 6.1	<u>70,000</u> 30	337 (19)	HARPOON 2X4 TARTAR 1X1 RAM AA 1X24 ASROC 1X8 127-mm gun 2X1 324-mm tubes 2X3 depth bomb 1	<u>4500</u> 20
HAMBURG - 4 D181 HAMBURG D182 SCHLESWIG-Hols. D183 BAYERN D184 HESSEN 1964 - 68	<u>3340</u> 4680	133.7 13.4 6.2	<u>68,000</u> 34	268 (19)	EXOCET 4X1 100-mm gun 3X1 40-mm gun 4X2 533-mm torp tubes 4X1 ASW rocket "Bofors" 2X4 racks (bombs/mines)	<u>6000</u> 13

GUIDED MISSILE FRIGATES

BREMEN - 6 F207 BREMEN F208 niedersachsen F209 RHEINLAND-PFALTZ F210 EMDEN F211 KOLN F212 KARLSRUHE 1982 - 84	<u>2900</u> 3500	130.5 14.5 6.0	<u>51,600</u> 30	204 (7)	HARPOON 2X4 SEA SPARROW 1X8 RAM AA 1X24 76-mm gun 1X1 324-mm torp 2X3 DC proj (also for mines)	<u>4000</u> 18
--	---------------------	----------------------	---------------------	------------	---	-------------------

FRIGATES

KOLN -3 F 222 AUGSBURG F 224 LUBECK F 225 BRAUNSCHWEIG 1962 - 64	<u>2100</u> 2700	110 11 5.1	<u>36,000</u> 28	210 (17)	100-mm gun 2X1 40-mm gun 2X1 533-mm torp 4X1 375-mm ASW rocket "Bofors" 2X4 Dpt. chg. proj 2 (also for mines)	<u>2900</u> 22
--	---------------------	------------------	---------------------	-------------	---	-------------------

CORVETTES (SMALL ASW SHIPS)

THETIS - 5 P6052 Thetis P6053 Hermes P6054 NAJADE P6055 TRITON P6056 THESBUS 1961 - 63 A1449 HANS BERKNER 1963	<u>564</u> 732	70 8.5 4.4	<u>6,800</u> 20	64 (4)	40-mm gun 1X2 375-mm ASW rocket "BOFORS" 1X4 533-mm torp 4X1	<u>3000</u> 12
1963	<u>1000</u>	81 9.4 2.8	<u>13,600</u> 20	50	375-mm "BOFORS" 1X4 533-mm torp tubes 2X1 Depth chg projectors	

TECHNICAL CHARACTERISTICS OF SHIPS AND CRAFT
OF THE FRG NAVY

Ship type - Number in commission (side # and name) Year entered fleet	<u>Std displ (t)</u> Full displ	Primary dim- ensions (m) length beam draft	Power (hp) Max speed (kt)	Crew size (Officers)	Armament	Range at kts
--	------------------------------------	--	------------------------------	-------------------------	----------	-----------------

GUIDED MISSILE PATROL BOATS

GEPARD TYPE 143A - 10 P6121-6130, 1982-84	<u>391</u>	57.7 7.6 2.5	<u>18,000</u> 36	34 (4)	EXOCET 4X1 RAM 1X24 ⁴ 76-mm gun 1X1 (also fires mines)	<u>2600</u> 16
TYPE 143 ALBATROSS 10 P6111-6120 1976-77	<u>391</u>	57.7 7.6 2.5	<u>18,000</u> 36	40	EXOCET 4X1 RAM 1X24 76-mm gun 2X1 533-mm torp tubes 2X1	<u>1300</u> 30
TIGER (TYPE 148) - 20 P6141-6160 1972-75	<u>265</u>	47 7 2.1	<u>12,000</u> 38	30 (4)	EXOCET 4X1 76-mm 1X1 40-mm 1X1	<u>600</u> 30

SMALL LANDING CRAFT

TYPE 520 - 22 ⁵ L760-769, 788-799 1965-66	200 <u>400</u>	40 8.8 2.2	<u>1020</u> 12	17	20-mm gun 1X2 Capacity: 160 tons cargo or 3 tanks	<u>3500</u> 8
--	-------------------	------------------	-------------------	----	--	------------------

LANDING CRAFT

TYPE 521 - 28 ⁶ LCM 1-28 1964-1967	<u>168</u>	23.6 6.4 1.5	<u>685</u> 10	7	Capacity: 60 tons and 50 marines	
---	------------	--------------------	------------------	---	-------------------------------------	--

MINEHUNTERS

LINDAU - 12 M1070-1072, 1074, 1075, 1077, 1078, 1080, 1084-87, 1958-59	370 <u>463</u>	47.1 8.3 3.0	<u>4,000</u> 16	43 (5)	40-mm gun 1X1 193M sonar, remote cont. minehunter PAP-104 -2	<u>850</u> 16
---	-------------------	--------------------	--------------------	-----------	---	------------------

"TROIKA" SYSTEM MINESWEEPERS

LINDAU - 6 M1073, 1076, 1079, 1081-1083 (1958-59)	370 <u>465</u>	47.1 8.3 2.8	<u>4,000</u> 16	44 (4)	40-mm gun 1X1 radio-contr. trawls - 3	<u>850</u> 16
---	-------------------	--------------------	--------------------	-----------	---	------------------

PATROL MINESWEEPERS

SCHUTZE - 21 M 1051, 1054-60, 1062-1065, 1067, 1069 1090-1097 (1959-63)	230 <u>305</u>	47.4 7 2.2	<u>4,500</u> 15	36 (4)	40-mm gun 1X1 various trawls	<u>2000</u> 13
FRAUENLOB - 10 M2658-2667 1966-69	204 <u>246</u>	38 8.2 2	<u>2000</u> 12	25 (2)	40-mm gun 1X1 varous trawls, also mines	
ARIADNE - 8 M2650-2657 1961-1963	200 <u>252</u>	38 7.7 2.2	<u>2,000</u> 14	25 (2)	40-mm gun 1X1 same as FRAUENLOB	<u>740</u> 14

MINE REPLENISHMENT SHIPS

SACHSENWALD - 2 A1437 SACHSENWALD A1438 STEIGERWALD	<u>3380</u>	110.9 13.9 3.8	<u>6200</u> 17	62	40-mm gun 2X2 up to 800 mines	3500
---	-------------	----------------------	-------------------	----	----------------------------------	------

- Note
1. The number of missiles and gun installations, the amount of launchers and barrels as well as the amount of torpedo installations and tubes are designated by the multiplication sign
 2. For submarines, surface displacement is shown as the numerator - submerged as the denominator
 3. The items of power, range and speed without brackets is in a surface condition; with brackets, submerged installation is programmed.
 4. Installation is programmed.
 5. Two are in reserve, one as a trainer. The foreign press calls these landing craft, the FRGN calls them small amphibious ships.
 6. In the reserve fleet.

these types have very low noise levels, making their detection by ASW forces very difficult; and they are equipped with quite modern torpedoes and mines. The tenders IAN and LEX are very similar: they displace 2,890 tons, are 98.4 m in length and can make a maximum speed of 20 knots; their operating range is 1,625 miles (at 15 knots) and they are armed with one 100-mm and two dual 40-mm cannons.

The destroyer flotilla (also at Kiel) includes five squadrons: the 1st and 2nd DESRONs consist respectively of 3 U.S.-built LYUJENS-Class DDGs and four HAMBURG-class DDs; the 2nd ASWRON (three KOLN-Class FFs); the 4th FFG squadron (six BREMEN-Class) as well as a squadron of corvettes (five THETIS-Class) and three support ships, used also as intelligence collectors. The 1st DESRON is based at Kiel, the corvette squadron at Flensburg and the remaining are assigned to Wilhelmshaven. The FRG Navy Command, as noted in the foreign press, considers that the combat strength of the flotillas must be maintained at existing levels, 16 destroyer and frigate type ships.

The missile boat flotilla at Flensburg has four squadrons. It is made up of 10 of the newest GEPHARD-Class boats (project 143A, 7th squadron at Kiel); 20 TIGRE-Class (project 148, 3rd and 5th squadrons, Flensburg and Olpe-nitze respectively). All these boats are equipped with the EXOCET antiship missile system (4-box launchers forward), and the latest ones also carry 533-cm torpedo tubes for firing wire-guided torpedoes.

There are six squadrons in the Mine Flotilla based at Wilhelmshaven: the 4th and 6th inshore minesweepers are deployed along the North Sea coast (Wilhelmshaven) and the 1st, 3rd, 5th and 7th harbor sweepers are based in the Straits zone (Flensburg, Kiel, Olpe-nitze and Neustadt, respectively). In all, the FRGN includes 59 mine ships (12 LINDAU-Class minesweeper-minehunters; and six TROIKA-system equipped ships(3); which are in the 4th and 6th squadrons; and 39 harbor sweepers (21 SCHUTSE-Class, 1st and 5th squadrons; 10 FRAUENLOB in the 7th squadron and in the 3rd, 8 ARIADNE-Class); 2 mine supply ships, A1437 SACHSENWLD and A1438, STEIGERWALD. The mine flotilla includes a system of mine destruction, about 100 miner-divers who are designated for destruction of detected mines and other explosive objects in coastal areas and along the shore.

The Supply flotilla (Cuxhaven) includes the 1st and 2nd support ship squadrons, based respectively in Kiel and Wilhelmshaven. It is responsible for at sea resupply of combatants and at dispersed basing points with necessary materials; it performs towing, icebreaking and rescue services, and guarantees security in combat preparedness areas. The flotilla has 24 vessels (eight multi-purpose supply ships; nine fleet oilers, two combat supply transports and five ocean-going tugs, including two rescue tugs).

An amphibious transport group (Kiel) is designated for sealift of landing forces, weapons, combat equipment and resupply material and for landing of marine amphibious forces and various surveillance-diversionary forces. It consists of a squadron of landing ships (19 small, Project 520 landing craft) and two amphibious transport battalions.

FRGN Aviation, in the West German high command's view, will be called upon to play an important role in the war at sea. In war time, it will execute the following primary missions: conduct missile and bombing strikes on ships at sea, against naval bases and coastal facilities of the enemy; search and destruction of enemy submarines independently and jointly with other naval elements; joint ASW defense of ships, landing detachments and transiting convoys, providing them air cover; air support of amphibious landings and ground forces in coastal operations; and conduct of search and rescue and transport operations.

Organizationally, units and detachments of naval aviation are grouped in a division, which has four squadrons; the 1st fighter-bomber (based at Schleswig/Yagel, 48 TORNADOS); the 2nd composite (based at Eggeback Field, 41 F-104G and 26 RF-104G STARFIGHTERS); the 3rd patrol GRAF ZEPPELIN squadron (at Nordholtz, 19 ATLANTIQUE landbased patrol aircraft, 5 of which are used for radio and radar reconnaissance operations and 12 ASW SEA LYNX helicopters; and, the 5th support Kiel/Holtenau, 20 light transport aircraft, DO-28D and 22 search and rescue SEA KING Mk-41 helicopters.)

The most modern aircraft in FRGN aviation is the TORNADO fighter-bomber, (Designed jointly by the UK, FRG and Italy). Their maximum speed is about 2,200 km/hr. at an altitude of 11,000 m, combat radius up to 1,200 km and their service ceiling is 15,000 m; depending on any given mission, their armament includes two forward 27-mm cannons, SIDEWINDER, SKYFLASH, MARTEL and CORMORANT guided missiles, air-to-air unguided rockets, and bombs (maximum combat weight of 7,250 kg). The F-104G STARFIGHTER fighter bomber is gradually being replaced by TORNADO. It has a maximum speed of 2,300 km/h (at an altitude of 11,000 m), an operating radius depending on combat load and flight profile of 1,100-1,300 km, a practical ceiling of 17,700 m; armament is one 20-mm cannon, SIDEWINDER guided missile, unguided air rockets, and bombs (max bomb tonnage, 1,800kg). The reconnaissance version (RF-104G has basically the same characteristics and also is scheduled for replacement by the TORNADO>

The communications and radio electronic commands has a staff and two communications links, while the tactical training group is concerned with collection and processing of geophysical information on the Baltic Sea.

FRGN SUPPORT COMMAND (Wilhemshaven) plans and organizes an entire range of measures in material support of the naval forces (procurement, accounting, storage and distribution of material and supplies, determines supply levels for each unit and detachment, verifies combat supply conditions, regular maintenance and ship repair schedules, controls compliance with regulations on weapons expenditures, and develops instructions and orders). It includes commands of naval basing regions on the Baltic and North Seas. The naval bases, supply and material depots and the two transportation battalions are subordinated to this command. The FRGN high command considers that combat readiness depends to a considerable degree on proper resolution of issues concerning rear security of forces, operating fleets and aviation.

CENTRAL NAVAL DIRECTORATE (Wilhemshaven) is responsible for manning, training and readiness of naval personnel, medical concerns, new equipment test and evaluation, and developing perspectives on combat specialties and

general issues. It includes detachments of personnel and test activities, an institute of naval medicine, personnel training schools, training centers and ships and vessels.

MANNING AND TRAINING OF PERSONNEL. Naval forces of the FRG (38,500 in number, including naval aviation) are recruited on the basis of a compulsory military service law (actual service tour is 15 months), as well as through voluntary enlistment who sign contract from 2 to 12 years. The fleet is essentially manned with volunteers; draftees comprise only about 26 per cent which is considerably less than in other armed forces (e.g., the average in the Bundeswehr is 45 per cent).

The FRGN, according to information in the foreign press, intends to decrease the number of draftees to 22 per cent. This is due in part to the fact that ship armament and air weaponry are becoming more complex technical systems, requiring a good deal of time to master and operate. It is a fact that presently submarine crews are fully volunteers, and on the new BREMEN-Class FFGs only 18.5 per cent of the enlisted and petty officer ranks are conscripts, called to duty under the compulsory military service laws.

Bundesmarine officers start out at the naval institute in Myurvik (about 2 years) following which all career officers, as well as officers on contract up to 12 years, complete a mandatory three-year course of instruction in the higher training establishments of the Bundeswehr. Along with instruction of theoretical disciplines, students complete practical work on the sail training ship GORCH FOCK and the training ship DEUTSCHLAND.

Petty officer and enlisted ratings go through various courses where they acquire the necessary qualifications for their specialties. In all, the FRGN numbers ten schools and four training groups.

West German military specialists consider that in the near future there will be a shortage of conscript cohorts for the FRGN. To solve this problem, in their view, they will have to increase the length of obligated service to 18 months, take in females to work in various shore duty assignments and in communications systems and make even broader introduction of automated systems and mechanization.

Along with training in national training establishments, they widely follow the practice of sending detached groups of servicemen to the fleets of the other NATO countries for even further honing of specialist skills in learning new techniques of foreign equipment.

BASING. The FRGN has a well developed basing system for fleet forces and naval aviation (see Fig. 3). According to JANES, the primary naval bases for the fleet are: on the Baltic, at Kiel (main), Olpenitz, Flensburg and Eckernfiord; on the North Sea, at Wilhelmshaven (main) and Borkum. In addition, more than 20 large ports in the country can be used for basing, drydocking and repair of combatants and naval auxiliaries. The Kiel Canal is a significant consideration for force and equipment movement.

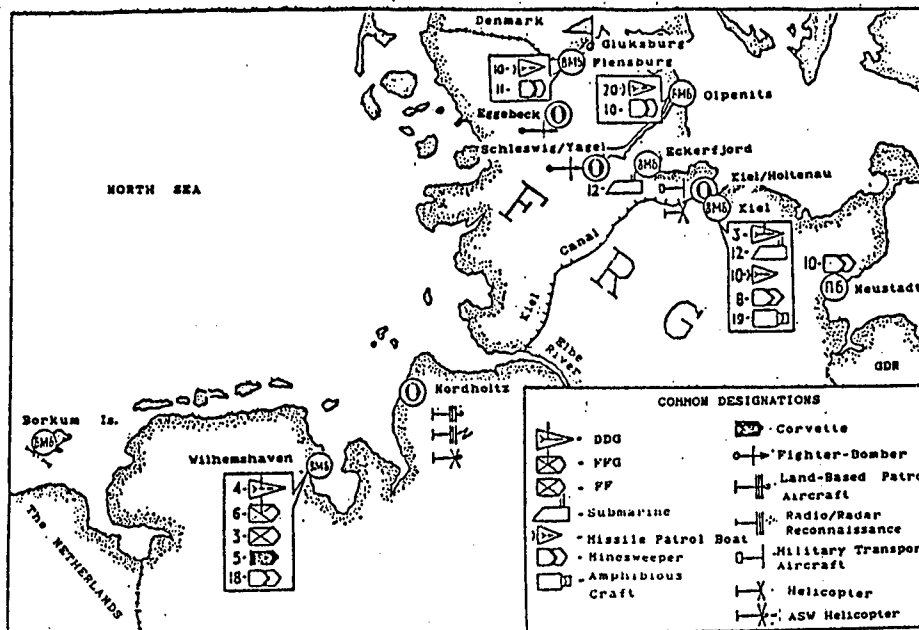

BME - Naval Base

HE - Tender

Figure 3. FRG Navy Bases

FRG naval aviation is based essentially at four fields: Schleswig/Yagel, Eggebeck, Kiel/Holtenau and Nordholts. These fields have landing/take-off strips about 2,500 m long with hard-surface (asphalt or concrete) taxiways, multiple and single tie-down points.

PERSPECTIVES FOR THE FUTURE. Judging from material in the foreign press, the Bundeswehr pays considerable attention to development of naval forces and increasing their combat capabilities.

Naval construction plans call for further qualitative improvements of submarines. Six submarines which have been in service since the end of the 1960s (Project 205), will be taken out of commission at the beginning of the 1990s; modernizing them does not appear expedient. They will be replaced by new Project 211 class (displacing 1,450 tons), planned, as observed by NAVY INTERNATIONAL, especially for operations in the shallow waters of the North Sea. Twelve such submarines are planned for construction. Project 206 submarines have increased their combat capabilities as a result of modernization (1985-90). They will receive wire-guided torpedoes, and in addition, several of them will have installed on their upper deck two fiberglass containers holding 12 mines each. In the future, some of these submarines will also be replaced by Project 211 submarines.

HAMBURG-Class DDGs, along with obsolescent Koln-Class frigates will leave the fleet around the 1995 period, after which two BREMEN-Class frigates and five FFGs of a new Project 124 will replace them. These new ships are expected in the fleet at the beginning of the 1990s. As reported in the foreign press, the

new FFGs are earmarked for defending the North Sea lines of communications from air attack. In 1986, modernization of the last of the LYUTJENS-Class DDGs was completed. These ships received the HARPOON antiship missile systems, the RAM (4) close-in air defense system as well as the NTDS tactical data system and an encrypted LINK-11.

The FRGN command considers that in order to increase the ability of their missile boats to survive an air attack they must be equipped with an effective close-in missile defense system. With this in mind, there is a plan to install on all Project 143 and 143A (in all 12 units) missile boats the RAM anti-air defense system with a range of 9 km, whose launchers handle 24 missiles. These will be installed in the stern area of the ships (in the Project 143 missile boats next to the 76-mm automatic gun).

It is planned to upgrade to a considerable degree the mine forces. In the very near future, construction will begin on a series of 10 units of new minesweeper-minehunters of the SHUTSE-Class. The lead ship, according to press releases, will be turned over to the fleet at the end of 1988. Minesweeper-minehunters of this class are earmarked for resolving problems of search, sweeping (including operating as a command ship in the TROIKA system), destruction of mines and the establishment of mine barriers. They displace about 400 tons and are 51 m long, have an 8.8 m beam, and draw 2.5 m; armament includes 40-mm guns. It is also planned to build yet another series of minesweeper-minehunter (Project 332, 20 units) with hulls similar to the Project 343 hulls. They will replace LINDAU-class ships.

Under review also is the question of replacing in the mid-90s their ATLANTIQUE landbased patrol aircraft, which only recently was modernized and equipped with a new radar, and more modern systems (radio and radar reconnaissance, sonobuoys, and inertial guidance). It is reported that either the ATLANTIQUE-2 or the U.S. P3-C ORION will replace the ATLANTIQUE.

In accordance with re-equipment and modernization programs for naval aviation, the obsolescent fighter-bombers (F-104G STARFIGHTER) and the reconnaissance RF-104G will be replaced by the TORNADO. The FRGN has ordered 112 of these aircraft. It is planned to complete re-equipping the 2nd composite sqadron in 1986-87. Capabilities of the TORNADO include its high combat load, according to foreign specialists, which is almost 4 times greater than the F-104G, and more modern onboard radar equipment.

In order to increase combat capabilities of naval aviation, it is planned to equip 22 search and rescue SEA KING Mk 41 helicopters with medium range antiship missiles. When modernization of these helicopters is completed, they should be capable of: over-the-horizon targeting for direction of "ship-ship" missiles; and, combat against enemy surface forces independently or in conjunction with missile patrol boats. As an effective weapon, they are regarding the British SEA SKUA (range 22 km), the Italian SEA KILLER Mk2 (25 km), the French AS-15TT (15 km) and the Norwegian PENGUIN Mk2 (30 km). However, latest reports indicate that they will choose the SEA SKUA. If so, the helicopter will be equipped with four launchers, the SEA SPRAY radar system, an encrypted LINK-11 and up to date radio and radar surveillance systems.

They also intend to upgrade the auxiliary fleet. In particular, two tanker-replenishment ships, the A1429 ENGELS and A1428 HARTZ will be replaced by new vessels and other ships and tugs will be constructed.

Implementation of the FRGN development programs will, in foreign defense specialists' opinion, increase their combat capabilities which will lead to an even greater role for the Bundesmarine in executing the aggressive plans of the NATO bloc. All the operational and battle readiness of the FRGN is aimed at this objective, which they will execute not only in their national planning, but also in the framework of the NATO joint armed forces in the Baltic Strait zone.

1. In 1961, the NATO council increases the allowed displacement of surface ships up to 6,000 tons, and in October, 1963, submarine tonnage was raised to 1,000 tons. In 1980, the latest limitations on warship construction, including nuclear-powered, were made at the request of the FRG.

2. Five THETIS-Class corvettes and A-1449 HANS BERKNER. The latter has retained its ASW armament, but it is operated by a civilian crew and is used as an experimental trial ship.

3. The TROIKA minesweeping system (a directing ship and three radio-guided trawl-boats) accomplishes search and sweeping of moored and bottom mines at depths of up to 300 m in sea state 3. The command ship is located at a safe distance from the sweeping area.

4. Lately there has not been any information the press about the RAM AA system on the LYUTJENS-Class ships, although they have considered it in their modernization plans.

COPYRIGHT: "Zarubezhnoye voyennoye obozreniye," 1986

9355

CSO: 1801/216

FOREIGN MILITARY REVIEW

U.S. NUCLEAR SUBMARINE COMMUNICATIONS

Moscow ZARUBEZHNOYE VOYENNOYE OBOZRENIYE in Russian No 5, May 86 (Signed to press 11 May 86) pp 56-59

[Article by Capt 1st Rank A. Markov (Ret); U.S. Nuclear Submarine Communications"]

[Text] Pentagon planners assign an important role in general nuclear war to nuclear powered ballistic missile submarines (SSBN), which, even in peacetime, are on patrol in constant readiness to execute orders to launch missiles against enemy targets. General purpose nuclear submarines (SSN), with intelligence missions, are on ASW barrier patrols, providing security to the fleet's strike forces and ever ready to use their own weapons (torpedoes and guided missiles, including antisurface missiles).

U.S. submarine forces have developed along both lines of increasing their combat power and to enhancing their invulnerability against enemy reaction. Among the most important measures which afford secrecy to underseas operations, the U.S. high command lists: a special operational regime for their activities; reduction of the level of physical fields, especially acoustic and electrical; and application of modern navigation systems. Modernizing existing and the design and building of new systems and means of communications with submarines, especially those at great depths, is, as the foreign press notes, fundamental to maintaining them in a state of high combat readiness.

Successful control of submerged submarines is quite a complex problem, which the U.S. Navy has been trying to overcome for the last 20 years, according to the foreign press. The main difficulty is that the radio signal penetrates a depth of water where its energy is absorbed depending on the wavelength, distance of the receiver from the transmitter, signal power, receiver depth, the speed of antenna movement and a range of other factors. The degree of absorption and the depth of signal penetration into the water medium are shown in Fig. 1.

Modern developments in electronic technology enable a sufficiently wide use of low frequency and very low frequency for communicating with submarines. Use of the even narrower, so-called extra low frequency (ELF) is loosely linked to the need to apply very high radiated power and large complex antenna systems.

Transmission of data through the water in the HF (optical) range demands energy concentration into a very narrow directional beam and is related to application of laser techniques in the region where the submarine is located.

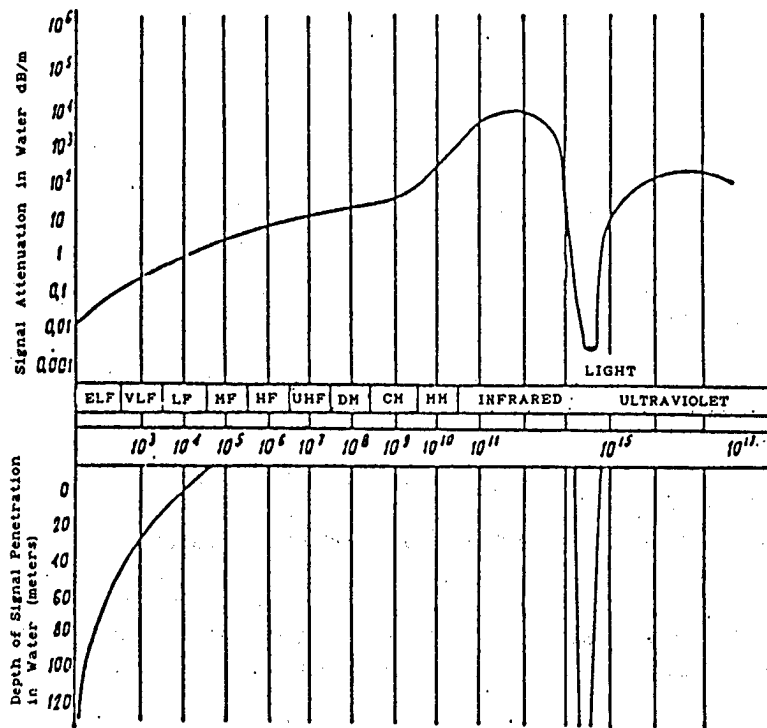

Figure 1. Graphic Depicting the Degree of Signal Absorption and Their Depth of Penetration in Water

At the present time, SSNs are controlled through a network of shore communications stations. They are distributed in all important world areas, contiguous to the sea areas where U.S. SSNs operate. The stations operate broadcasts for them without requiring acknowledgement. To increase communications reliability, each region of the theater operates at least two stations which, through the use of VHF, HF, LF and VLF bands repeat the basic message many times.

VHF transmissions are line-of-sight or via satellite (frequency 225-400 MHz) FLTSATCOM, which in the latter part of the 1980s, will be replaced by LEASAT. Four satellites of the latter system are already in stationary orbit.

One of the channels of the satellite (25 kHz bandwidth) is designated for retransmission of fleet broadcast transmissions, including those for submarines. In this mode transmission "ground to satellite" are in the

centimeter band and "Satellite to ship" in the decimeter. The AN/FSC-79 groundbased system is used to transmit broadcast traffic. It is installed at the primary communications centers at Norfolk (U.S.), Honolulu (Hawaii), Naples (Italy), Guam (Pacific) and Diego Garcia (Indian Ocean) Transmissions are received on SSNs with a unique (in the Navy) receiver, the AN/SRR-1. To assure communications reliability and to increase channel capacity for the broadcast, transmissions to SSNs employ digital equipment, permitting information transfer at speeds of 2,400 BPS. This equipment is deployed at shore communications centers and on submarines and allows high speed transmissions as well as ship to shore.

The HF band (3-30 MHz), relative to the other bands, is used as a backup, because its signal path is not sufficiently stable and it is subject to countermeasures. It requires a considerable time to establish and conduct communications.

To receive VHF and HF signals, submarines have to be either on the surface or at periscope depth and use retractable antennas.

The majority of shore naval communication stations, as well as U.S. stations, deployed in the European countries and in the Western Pacific, are equipped with LF transmitters, ensuring communications at ranges of 3,000-4,000 km. Primary shore communications stations have VLF transmitters (3,039 kHz) which ensure communications with submarines at distances up to 16,000 km. There are seven such stations in the U.S. Navy today; three of them--Annapolis (Washington), Lualualei (Hawaii) and Balboa (Canal Zone)--were built before WWII and have been modernized several times. In the 1960s, they built the communications stations at Cutler (Maine), Jim Creek (Washington), Northwest Cape (Australia) and San Francisco (California). The Cutler transmitting site is equipped with one transmitter of 2,000 KW power, Jim Creek has two 1,000 KW and the rest have one 1,000 KW transmitter. Basic working frequencies are 14-35 kHz.

The foreign press notes that shore stations, especially the VLF ones with their massive antenna fields, are subject to enemy interference. The antenna field at Cutler covers about six km². Several antenna sections are located there, mainly rhombics, suspended on steel supports at heights from 250 to 300 m. The U.S. Command has stated that, at the outset of combat action, the majority of communications stations could be destroyed. Therefore, they consider that, for reliable control of submarines, primarily missile boats, it is necessary to have communications systems with increased survivability, range and depth of submerged travel of signals.

Major hope in solving this problem was placed on development, again in the 1960s, of a reserve system of VLF communications, installed on airborne relays, called TACAMO. It must transmit in a timely fashion and with great reliability the orders to SSBNs to employ nuclear weapons. In the aircraft TACAMO system, messages are placed on the broadcast channel for submarines and on special lines linked with the high command of the armed forces and U.S. Navy.

The EC-130 airborne relays, or TACAMO, are organized into two squadrons with nine aircraft each, operating in the Atlantic and Pacific theaters. They are especially equipped for watch sections with equipment for receiving and relaying signals to submarines. The watch section is situated in the forward fuselage section with the central control post, operator stations, which control exchange of information over telephone and teletype communications channels, and the VLF transmitter operator station. The receiving and transmitting equipments, power amplifiers, information processing equipment, the output stages of the transmitter and equipment for antenna matching are located in the tail section.

TACAMO communications equipment includes: four AN/ARC-138 VHF radios, two AN/ARC-132 HF equipments, one AN/ARC-146 satellite communications station, as well as HF, MF, LF and VLF receivers. For communications relay, the aircraft has an AN/ARQ-127, narrow band 200 kW VLF transmitter operating on a frequency of 21-26 kHz. Transmissions to submarines are in teletype and manual telegraphy (morse code) form. One element in improving communications is the towed antenna 10 km long, which is reeled in and out on a special rig.

During their airborne shift, the aircraft-relay conducts its flight in assigned areas at 8,000 m altitude and at 330-550 km/hr in an 185 km circle with antenna reeled out. The summary data from the multi-year experience of the TACAMO system, according to the Western press, shows that their transmissions have been received by submarines at antenna depths of 15 m and at ranges from the aircraft primarily at relatively short distances, but possible up to 10,000 km.

According to the foreign press, the TACAMO system is being improved. The aircraft's radio equipment has been improved and updated, broadly incorporating computer technology. Fifteen E-6A aircraft have been ordered, designed along the lines of the Boeing 707. Commencing in 1987, as service life becomes depleted, the EC-130Q will be replaced by the newer E-6A.

For communications with submarines at any time and at depths which protect the secrecy of their activity, the U.S. has begun using ELF band (0-3,000 Hz), whose waves have a negligible coefficient of attenuation on penetrating the water medium (up to .1 dB/meter) and an increased resistance to radiations from nuclear blasts. With a sufficiently powerful transmitter, ELF can propagate to distances over 10,000 km and penetrate the water to depths of 100 m.

In the 1960s, attempts were underway to build such a system, but, because of the high cost and many other reasons, the project was scrapped and the test center closed in 1978.

In 1981, the U.S. government authorized a less-expensive project for this communications system now known as ELF (Extremely Low Frequency) at a cost of 230 million dollars. Plans call for two transmitting centers with 3-5 MW transmitters. One will be the modernized test bed station in the state of Wisconsin, where an increased power transmitter is already installed. In 1982-84, several experimental transmissions were made from this station to submerged submarines. They received the signals at depths up to 100 m and at

speeds of up to 20 kts. The second center is being built in Michigan. To simplify construction and exploitation, the antenna system (general length of about 100 km) will be suspended on steel towers 1.8 m high.

The frequency of 45-80 Hz has been selected for communications use, over which will be sent commands, consisting of 3 letters, lasting 5-20 minutes. The Navy considers that this system will be an auxiliary one whose objective will be to advise the submarine to come to shallow depth and receive messages via other communications means. Once the system is completely on line, it is planned to equip all SSBNs and SSNs with receiving equipment. Center operations will be controlled from one control center, although they will be serving different theaters. When there is a necessity for increased reliability for receipt of especially important information, both centers can be synchronized, which increases the radiated power.

Communications reliability with submerged submarines can be increased through the use of laser radiations. This communications system, widely acclaimed in the Western press, permits transmissions to submarines at depths greater than 100 m, a greater capacity of data, and a higher data rate. They claim that it does not require use of any other backup means of communications, since satellite laser communications can assure operational-tactical and strategic control of forces.

As the foreign press has noted, the most efficient wavelength for communications in the light band is the blue-green spectrum (.42-.53 mkm), which can pierce the water medium with minimum loss and penetrate to depths of 300 m. However, building a laser communications system is not without a number of technical difficulties. They are currently conducting laser experiments, in which they are examining three basic variants for use.

The first variant is a passive satellite relay equipped with a large reflector (7 m in diameter, about 1/2 ton) and a powerful ground laser transmitter. In the second variant, it is necessary that the satellite have a sufficiently powerful transmitting device and a power plant several orders higher. In both variants, communications reliability is guaranteed through a high-precision system of guiding and accompanying the communications target with a laser beam. A third variant is under examination, wherein they are looking at development of a laser beam, using a lens and mirrors which will concentrate solar energy.

The state of current technology, in foreign specialists' opinion, will permit laser power in the first variant of 400 watts with a pulse repetition frequency up to 100 Hz, and in the second, to deploy in orbit 10-watt lasers with pulse repetition frequencies of 18 Hz. experimental types of laser communications systems may be developed in the 1990s, but working devices will not be built before 2000.

Submarines, irrespective of their employment while executing assigned combat missions, operate in radio silence in order to maintain secrecy. Only in extraordinary circumstances, involving emergencies, inability to carryout combat assignments and reports of especially important information do they transmit. In order for an SSBN to remain on the surface or at periscope depth

for a minimal time to conduct radio communications, those communications must be transmitted at very high speeds in digital format and through the FLTSATCOM satellite system, as well as in the HF band. The existing network of shore stations assures receipt of such transmissions on varying HF frequencies with high reliability.

In peacetime when sailing on the surface, submarines may employ the entire range of radio equipment on board.

In the OHIO-Class SSBNs, the installed radio equipment has been designed according to a project called "integrated communications center." It provides for equipping the radio room with automated systems of communications control and message distribution, which enables them to reduce the number of watchstanders to one or two. For the LOS ANGELES-Class SSNs, a unified communications center has been designed which includes ship transceivers, signals intelligence equipment, communications countermeasures, identification systems and underwater communications. Automated systems on these ships and on SSBNs includes the AN/UYK-20 computer.

The communications package on nuclear submarines includes: one ELF receiver (installations now beginning); two MF, LF and VLF (10-3,000 kHz) receivers; several HF receivers; AN/SRR-1 installation for general message transmission via FLTSATCOM satellite; two HF transmitters (1 kW power); permitting duplex communications between the submarine and the shore using manual and automatic morse telegraphy and radiotelephone; two 1 kW HF transmitters (2-30 MHz); two VHF systems (one AN/WSC-3) enabling communications of all types with shore stations and moving objects through the satellite system. A special system of digital communications guarantees a highspeed data transmission rate.

The antenna systems on submarines is the fundamental source of reliable radio communications. These are (Fig. 2): a wire antenna, over 1,000 m long, towed at depths below 100 m, for ELF reception (not yet installed); a towed wire antenna (300-900 m) for LF and VLF reception. In order to expose the active elements of the antennas for reception (no more than 20 m), the submarine comes to a 30 m depth and when its depth is less than 60 m, the antenna is supported at reception depth by a buoy; a towed VLF loop antenna has a working reception depth under 10 m, which determines submarine speed (up to 3 kt) and length of tow (500-600 m); and an onboard loop antenna for VLF reception at depths no greater than 30 m.

Transmitting and receiving omnidirectional antennas for HF and VHF (helical and whip) as well as satellite communications systems are installed on retractable masts and are used only when the submarine is on the surface or at periscope depth. The satellite system antennas are a directional grid with gyro servomechanisms for maintaining it on the proper azimuth and with manual range control to bring it to bear according to the angle.

Submerged SSNs communicate in HF and VHF using the AN/BRT-3 radio buoy. Beginning in 1981, these buoys have been modernized and their VHF antennas have been replaced with satellite communications.

Emergency communications from submarines to ships, aircraft and shore stations is done by an automatic system, transmitting in HF through a buoy launched

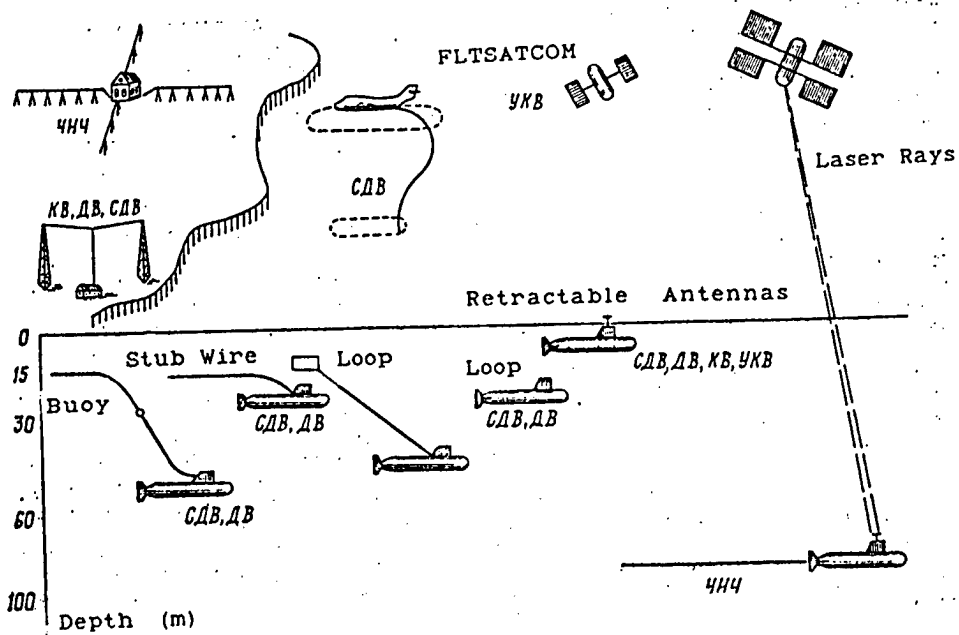

ЧНЧ = Extremely Low Frequency
 ДВ = Long Wave

УКВ = Short Wave
 СДВ = Very Low Frequency

Figure 2. Types of Submarine Antennas for Receiving Radio Transmissions at the Various Wave Lengths

from the submarine and floating on the surface. This communications buoy is equipped with a telescoping antenna.

This short overview of information reported in the writings of the foreign press points out the U.S. Navy's urgency to develop reliable systems of submarine control.

COPYRIGHT: "Zarubezhnoye voyennoye obozreniye," 1986

9355
 CSO: 1801/216

FOREIGN MILITARY REVIEW

JAPANESE SHIPBUILDING

Moscow ZARUBEZHNOYE VOYENNOYE OBOZRENIYE in Russian No 5, May 86 (Signed to press 11 May 86) pp 61-70

[Article by Capt 1st Rank Yu. Shitov; "Japanese Shipbuilding"]

[Text] The Japanese Navy plays an important role in U.S. strategic plans in the Far East. Under U.S. pressure, Japan has assumed responsibility for defense of sea lanes out to 1,000 nautical miles from the main islands. These responsibilities have found expression in the politico-military leadership's undertaking to increase the Navy's capabilities. Sharing joint Japanese-American naval information and instruction, the Japanese Navy is being enlarged with modern surface ships and submarines of indigenous production, which in fundamental technical characteristics and armament are as good as similar classes of Western European nations.

In recent years, Japan's naval budget has risen at a much faster rate than defense expenditures on the whole, which demonstrates what level of priority is given to development of naval forces. In Japan's armed forces building plan for FY 85 (beginning 1 April) resources are available to build a YUSHIO-Class submarine, three DD-134-type DDGs and two HATSUSHIMA-Class minesweepers. Conforming with the plan, they are continuing construction, in accordance with earlier placed orders, of two YUSHIO-Class submarines, three HATSUYUKI-Class DDGs, and four DD-134-type DDGs, one HATAKAZE-Class DD, two HATSUSHIMA-Class minesweepers and an all-purpose supply transport TOWADA. In addition, construction has been completed on seven ships and vessels: a submarine, OKISHIO, DDGs HATAKAZE, YAMAYUKI, and MATSUYUKI, the minesweepers NUWAZHIMA and ETAZIMA and the hydrographic vessel WAKASA. In the judgement of one American center of information on defense issues, Japan requires no less than 25 submarines and 75 DDs and FFs to control the 1,000-mile zone.

According to the Japanese reference work "Cantei-to kokushyu," in March 1986, the Japanese Navy numbered 106 warships (14 diesel submarines, 16 guided missile destroyers (DDG), 17 destroyers (DD), 3 guided missile frigates (FFG), 15 frigates, 8 amphibious ships, 32 inshore minesweepers, and 1 minelayer) and 20 small craft (5 torpedo boats, 9 patrol boats and 6 minecraft). In addition, Japan's reserve fleet contains 29 ships; 1 submarine, 11 destroyers, 5 corvettes (small ASW ships) and 12 minesweepers.

The Japanese shipbuilding industry has extensive experience in constructing warships of various classes. Near the end of the Second World War, Japan had deployed one of the most powerful fleets in the world, including almost 400 warships and craft, over 600 auxiliaries, and a personnel strength of 250,000. The basic centers of shipbuilding were naval depots located in Yokosuka, Kure, Sasebo and Maizuru. In 1930, Japanese Navy warship construction amounted to 110,000 tons displacement; in 1940, 211,000 tons; in 1941, 120,000 tons; 1942, 118,000 tons; in 1943, 239,000 tons; and in 1944, 468,000 tons. In 1944 alone, when Japan reached a maximum level of construction, she constructed 4 aircraft carriers, 37 submarines, 1 cruiser, 31 DDs, and a large number of ships of various classes and auxiliaries. In the period from 1940 to 1945, in addition to naval ships, Japan built merchant shipping with a total of 3,937,000 GRT (gross registered tons). The productive strength of the Japanese shipbuilding industry in 1944 consisted of 2,263,000 GRT and in ship repair, 10,238,000 tons. Shipbuilding was designated "Top priority." Supplying it with materials and labor was conducted under the constant supervision of the naval bureaus and the government.

During the war, Japanese shipbuilding was essentially undamaged, but until 1950, growth was stagnant as a result of prohibitions and limitations imposed by American occupation authorities. In this period, no construction without special permission was allowed for wooden or steel-hulled ships over 1,000 tons. Overall in one year, they could only build ships whose total capacity did not exceed 150,000 GRT.

Revival of commercial and warship construction in the 1950s was conditioned by the unleashing of American aggression in Korea, as a result of which the demands for commercial shipping increased, sparking a need as well to repair U.S. warships. Existing yards were renovated and new shipbuilding facilities were built. Japanese industrial policy, during the 1950s, including development of a shipbuilding industry oriented for export and based on use of the most up-to-date foreign achievements in the field. Capital outlays in the 1950-60 growth period reached almost 70 billion yen. To increase its competitive ability, Japan moved toward reducing construction time alternately increasing and decreasing its net worth through incorporation of metal conservation and labor-saving technologies. In 1956, Japan built 400 ships with a gross capacity of 2 million GRT, as a result of which, she attained by all basic indicators, first place in the world in shipbuilding and has retained that position ever since.

The Japanese commercial fleet, numbering 1,587 ships with gross capacity of 2,787 thousand GRT, leaped, over a 10-year period, to more than 4,000 ships with a total capacity of 9 million GRT.

From 1960-69, capital outlays in shipbuilding were 296.4 billion yen. This period saw a move toward construction of heavy tonnage ships, particularly supertankers and container carriers.

Graving docks and cradles were built, permitting construction of 300,000-500,000 deadweight ton ships, and through a method of twin-section assembly, up to 1 million tons.

In 1975, the worldwide shipbuilding boom reached its peak. In that year alone, Japan built 930 ships with a capacity of 17 million GRT, which comprised 49.7 per cent of the entire world tonnage. The economic crisis begun in the West sharply curtailed new ship orders and a significant drop in worldwide construction ensued. Japanese shipbuilding firms closed down parts of their ways and docks and some companies redirected production towards other goods. At the outset of the 1980s, the productive capability of these firms decreased to about a total capacity of new ships to 12 million GRT per year, however, they are utilizing only 50-60 per cent of capacity (in 1984, a 3-year plan was developed, reducing industrial capacity by another 4 million GRT. Total tonnage of shipping built in 1984 was about 8 million tons. Presently Japanese shipbuilding is focused on building technically-complex ships as well as assets for maritime exploration and drilling for oil and gas. Projects have been developed for construction of large floating hotels, airports and industrial complexes.

A high degree of monopoly characterizes Japan's naval shipbuilding programs. Out of the more than 100 shipbuilding firms in the country, only 8 fill naval orders, of which over 25 per cent belong to the "Mitsubishi Jyukoge." Orders for warship construction are placed in such a way as to give the leading construction firms the opportunity to gain experience in program planning and modern warship construction, in training technical cadres and outfitting for mobilization deployable units. In foreign specialists' opinion, it is clear, that by this approach, multiple variations of types of ships of one class can be written and that a single type ship can be built simultaneously at several yards.

Distribution of funds to build the first warships in the postwar period started in 1953 (immediately following the renaissance of the Japanese Navy). Construction was in accordance with annual and 5-year plans as well as mid-term shipbuilding programs (see table 1). From 1953-57, it was planned to fund construction of 51 ships and craft, intended for the limited tasks related to coastal defense. These first ships and their armament were patterned after the American Navy.

The first two 1700-ton destroyers were laid down in December 1954, on the Mitsubishi quays in Kobe and Nagasaki. They entered the Japanese fleet in April, 1956 as HARUKAZE and YUKIKAZE.

From 1955-60, seven AYANAMI-Class DDs were built, as well as three MURASAME and two AKIZUKE. These ships did not differ to any degree from the HARUKAZE-Class destroyers.

A new stage in Japan's shipbuilding was reached with construction of the first guided missile destroyer (DDG) AMATSUKAZE, with a 3050-ton displacement and a steam turbine main propulsion plant. In addition to guns and torpedos, the TARTAR anti-air missile system was installed as was the ASROC ASW missile. The ship entered the fleet in 1965. By the end of the 60s and early 1970s, six YAMAGUMO-Class and three MINEGUMO-Class 2050-2150 ton destroyers had been built. Plans, designs and armaments for these ships were Japanese.

TABLE 1
Japan's warship construction program (1953-1990)

	SS	DDG	FFG	DD	FF	CORVETTE	MINESWEEP	AMPHIB SHIPS
ANNUAL PLAN (1953-57)	1	-	-	12	3	10	10	-
Warship construction Plans:								
1958-61	5	1	-	2	4	7	10	-
1962-66	4	-	-	9	-	3	11	-
1967-71	5	1	-	5	7	-	11	1
1972-76	3	1	-	3	4	-	10	5
ANNUAL PLANS (1977-79)	3	6	2	-	-	-	6	2
Shipbuilding Plan (1980-84)	5	13	1	-	-	-	12	-
Mid-Term Programs								
1983-87	6	11	3	-	-	-	13	5
1986-90	5	3	6	-	-	-	13	4
Number of ships and craft in commission as of March 86	14	16	3	17	15	-	33	8

Note 1. Planned programs without authorization

Note 2. Minus reserves

A broadened scope of military problems, imposed on the Japanese Navy, demanded construction of ships with improved ASW weapons and greater combat range. In 1973/74, these were filled in part by two 4,700-ton HARUNA-Class helicopter destroyers (DDH). The power plant consists of two steam turbines and a total power of 70,000 hp. In addition to two 127-mm cannon and the ASROC missile, these ships each carry onboard three HSS-2B (SEA KING) ASW helicopters produced in Japan. In 1984-86 fiscal years, funds are allocated for modernization of both ships, during which they will be equipped with the SEA SPARROW air defense missile, and two VULCAN-PHALANX 20-mm air defense installations.

At the present time, the largest ships in the Japanese Navy are the SIRANE-Class DDH, with a displacement of 5,200 tons, which entered the fleet in 1980 and 81. This class ship is equipped with the SEA SPARROW air defense missile, ASROC ASW missile, twin 127-mm cannons, twin 20-mm VULCAN PHALANX air defense system, the OPS-12 three-dimensional radar, the OPS-28 surface search radar, the OQS-101 hull-mounted sonar, the SQS-35J variable depth sonar and the SQR-18A TACTASS, towed low frequency, linear array. Each ship has three HSS-2B ASW helicopters. The LINK-11 and 14, tactical data communications and encryption systems, installed in the DDH, allow the exchange of tactical information not only with other Japanese ships, but also with Americans.

In 1976-83, Japan constructed three TATIKAZE-Class DDGs, with a displacement of 3,900 tons, equipped with the TARTAR missile system, the ASROC ASW missile, two 127-mm cannons and two 324-mm torpedo tubes. Later (1985), two ships were reequipped (each with two VULCAN PHALANX AA systems). A distinctive feature of the third ship of this series (the SAVAKAZE) is a modernized TARTAR launch system, which can also be used to fire HARPOON.

The HATAKAZE-Class DDG represents the latest developments in TATIKAZE-Class warships, with a displacement of 4,500 tons. The lead ship was commissioned in March, 1986. Among its weapon suite are the armored 4-box launcher for the HARPOON missile, three TARTAR missile systems, the ASROC missile, two 127-mm cannons, two 20-mm VULCAN PHALANX AA systems, two 3-tube 324-mm torpedo tubes. A HSS-2B helicopter is carried on board.

Since 1982, HATSUYUKO-Class DDGs have joined the Japanese Navy. Nine units had been built by April, 1986, and construction is continuing on three others. The standard displacement of the first seven of these ships is 2,959 tons. These were the first ships in the Japanese Navy to have a COCOG-type propulsion plant, which consists of two TAIN RM1C cruising turbines (total power of 10,680 hp) and two full speed OLYMPUS TM3B gas turbines (45,000 HP). Notwithstanding the rather small dimensions and displacement, the ships carries substantial ASW (ASROC), AAW (SEA SPARROW) and ASUW (HARPOON) missile ordnance, as well as a single-barrel 76-mm gun. The hull is made of high-durable steel and the superstructure, stacks and masts are of aluminum alloys. HATSUYUKI-Class DDGs are equipped with an active pitch stabilization system using the onboard rudders. Since, in contrast to other Japanese surface warships, the weight of the main engines is comparatively low, to increase transverse stability it is planned to take on ballast commensurate with fuel expenditure.

In 1982, based on an analysis of British warship combat experience in the Falklands conflict, Japanese warship construction introduced several ship design changes: it was decided to install two 20-mm VULCAN PHALANX AA systems per ship to strengthen their capabilities against lowflying anti-ship missiles. In addition, they decided to change the construction material (from aluminum alloy to steel), and to increase survivability to relocate the combat information center to a location within the hull (commencing with the 8th in the series, DD 129).

In conjunction with design changes, the ship's displacement increased to 3,070 tons. There is ongoing construction of 4 DD-134-Class DDGs with a displacement of 3,400 tons, which represents the latest development of the HATSUYUKI-class ships, and another 4 units have been authorized for construction in FY 85-86.

Frigate construction has been going on since 1954. By March 1985, two IKAZUTI-Class frigates had been built, along with one AKEBONO, four ISUZU, eleven CHIKUGO, as well as FFGs: one ISHIKARI-class and two IBARI. Japanese frigates have standard displacements of 1,000-1,400 tons, and modern ASW weapons (including ASROC). On the FFGs, instead of the ASROC, there are four-box HARPOON missile launchers. Six shipyards share the experience of frigate construction.

Production of corvettes (small ASW ships) is not widespread in Japan. From 1956-66, 20 ships of this type were constructed: one HAYABUSHA; seven KAMOME; four UMITAKA and eight MIZUTORI. They displace about 400 tons, have a speed of up to 20 knots and their armament is basically ASW. As of the present time, 14 have been scrapped, 5 are in the reserves and 1 has been turned into a floating barracks.

Minesweeper construction has been ongoing since 1954 in four yards. Up to the present, 63 units of four classes have been launched. The most modern are the HATSUSHIMA-Class inshore minesweepers which displace 440 tons, being built at the rate of two per year at the "Hitachi-Joshen" yards in Maizuru and in the "Nippon kokan Jyukoge" yards in Tsurami since 1977. In all 15 units have been built, 2 are under construction and 2 others have been authorized. Seven more minesweepers are expected to be built.

Submarine construction is done at two yards (both in Kobe), belonging to the "Mitsubishi Jyukoge" company and "Kawasaki Jyukoge". The first submarine of post war construction was the OYASHIO, displacing 1,139 tons, built in 1960. Subsequently, in 1961-63, two submarines each of the HAYASHIO and WAKASHIO-Class (750 tons) were built, in 1965-69, one OOSHIO-Class and four ASHASHIO-Class (1,650 t.) were constructed; and in 1968-78 seven UZUSHIO-Class submarines (1,850 ton). With the UZUSHIO as a baseline, design of the YUSHIO-Class was developed, displacing 2,200 tons with six midships torpedo tubes, arranged at a 10° angle from the centerline. The submarine has a teardrop-shaped hull, characteristic of atomic submarines and is built of high strength steel.

The lead ship joined the fleet in 1980. In March 1986, the seventh boat of this project was laid down (it was the third ship armed, in addition to torpedoes, with the antiship missile HARPOON which is fired through the

torpedo tubes while submerged). An eighth ship has been launched and funds have been allocated for yet two more.

Over all, during the postwar years, Japan has allocated funds for construction of 263(1) combat ships, craft and auxiliary ships with an overall displacement exceeding 330,000 tons. Of these, 184 warships entered the fleet: 24 submarines (seven classes); 14 DDGs (four classes); 3 FFGs (two classes); 31 DDs (nine classes), 18 FFs (four classes); 20 corvettes (four classes); eight amphibious ships (three classes) 63 minesweepers (four classes); 3 mine supply ships (three classes); and 36 combat craft. Warship construction rate of the basic ship classes now in the fleet is shown in Table 2.

In September 1985, the Japanese government reaffirmed its priority program for armed forces buildup in the FY 1986-90 period. In accordance with this program, it is planned to allocate funds to construct 35 ships, craft and vessels including five submarines, three DDGs, six FFGs, four amphibious ships, ten minesweepers, three rocket cutters, two multipurpose replenishment ships, one combat readiness vessel and one training ship.

A new type of submarine is planned, displacing 2,400 tons and equipped with the HARPOON antiship missile. Of the three DDG, one will be a DD134 class (the eighth in the series) and two of a new 6,500-ton class, equipped with the AEGIS multipurpose weapon system. They are planning to build a new class, a 1,900-ton FFG, equipped with HARPOON, ASROC, and the RAM AA system. They also expect, that of the four amphibious ships, one will be of a new, 3,500-ton class and three of 450 tons. Of the minesweepers proposed for construction, seven are of the HATSUSHIMA-Class (19-25th in the series) and three of a new, 100-ton class. New 65-ton rocket cutters will be equipped with HARPOON and a 76-mm cannon, as well as the VULCAN PHALANX anti-air system. They are also planning to build the 8,300-ton TOWADA-Class multipurpose replenishment ships (2nd and 3rd in the series), combat readiness ships (2,200 tons) and a new class training ship (3,500 tons).

In accordance with the FY86 Japanese budget, seven ships are authorized: one submarine, one DD134-Class DDG, two FFGs, two HATSUSHIMA-Class minesweepers, a small 420-ton landing ship and a new class combat readiness ship (these will join the fleet in 1988-91).

In the current fiscal year, Japan intends to commission TAKESHIO, a YUSHIO-Class submarine, three HATSUYUKI-Class DDGs (SETUYUKI, ASHAYUKI and SHIMAYUKI), two HATSUSHIMA-Class minesweepers (MSC 664 and 665 - the 16th and 17th of the series) and the lead replenishment ship of the TOWADA-Class. In addition, construction is continuing on ships from earlier contracts: two submarines, eight DDGs and two minesweepers which will enter the fleet in 1987-90.

Below, according to the foreign press, are given brief characteristics of Japan's shipbuilding companies which launch ships and vessels for the Navy (their locations within the country are displayed in Fig. 4).

TABLE 2
JAPANESE SHIP CONSTRUCTION OF BASIC SHIP CLASSES

Class of ship (building years for the series)	Ship totals ¹	Construction yards					
		Mitsubishi	Ishikawajima	Hitachi	Kawasaki	Mitsui	
SUBMARINES		Shumitomo					
YUSHIO 1980-88	$\frac{7+2+1}{7}$	4+1	-	-	-	3+1+1	-
UZUSHIO (1971-78)	$\frac{7}{7}$	3	-	-	-	4	-
ASASHIO	$\frac{4}{0}$	2	-	-	-	2	-
GUIDED MISSILE DD							
HATAKAZE (1986-88)	$\frac{1+1}{1}$	1+1	-	-	-	-	-
DD 134 (1988-91)	$\frac{0+4+4}{9}$	0+0+1	0+2+1	0+0+1	0+1+10	-	0+1
HATSUYUKI	$\frac{9+3}{9}$	1+1	3	2	2+1	-	1+1
TACHIKAZE(1976-83)	$\frac{3}{3}$	3	-	-	-	-	-
AMATAZUKE (1965)	$\frac{1}{1}$	1	-	-	-	-	-
DESTROYERS							
SHIRANE (1980-81)	$\frac{2}{2}$	-	2	-	-	-	-
HARUNA (1973-73)	$\frac{2}{2}$	1	1	-	-	-	-
TAKATSUKI (1967-1970)	$\frac{4^3}{4}$	2	2	-	-	-	-
YAMAGUMO (1966-68)	$\frac{6^4}{6}$	-	-	-	3	-	1
MINEGUME (1968-70)	$\frac{3^4}{3}$	-	-	-	1	-	-
AKIZUKI (1060)	$\frac{2^2}{2}$	2	-	-	-	-	-
MURASAME (1959)	$\frac{3^2}{0}$	1	1	-	1	-	-
AYANAMI (1958-60)	$\frac{7^2}{2}$	2	1	1	-	1	2
GUIDED MISSILE FFs							
YUBARI (1983-84)	$\frac{2}{2}$	-	-	1	1	-	-
ISHIKARI (1981)	$\frac{1}{1}$	-	-	-	-	-	1
FRIGATES							
CHIKUGO (1970-71)	$\frac{11}{11}$	-	1	3	-	-	7
ISUZU (1961-64)	$\frac{4}{4}$	1	1	1	-	-	1

Note 1. Numerator is ship totals built + under construction + authorized. Denominator is ships in commission in March 1986

Note 2. Some of these ships are obsolete and in reserve

Note 3. Two ships, modernized, are reclassified as DDGs

Note 4. One each of these ships have been built by "UGARA JYUKOGE" and MAIZURU JYUKOGE"

MITSUBISHI JUKOGE, founded in 1853, is the oldest shipbuilding enterprise in the country. It leads the world in the amount and tonnage of ships it has launched. Its quays in Nagasaki in 1942 build the largest battleship in the world, the YAMATO-Class MUSHASHI with a 64,000-ton standard displacement. The company operates 5 plants in Nagasaki, Kobe, Yokohama, Shimonosheki, and Hiroshima, equipped with 2 giant drydocks (in Nagasaki) capable of launching ships from 330,000-500,000 deadweight tons, and 8 graving docks and 13 dry and 4 floating docks. In addition to ship construction wharves, the company owns a variety of factories which produce steam boilers and turbines, diesel engines, reduction gears, turbogenerators, propellers, pumps, winches, separators and other ship auxiliary equipment.

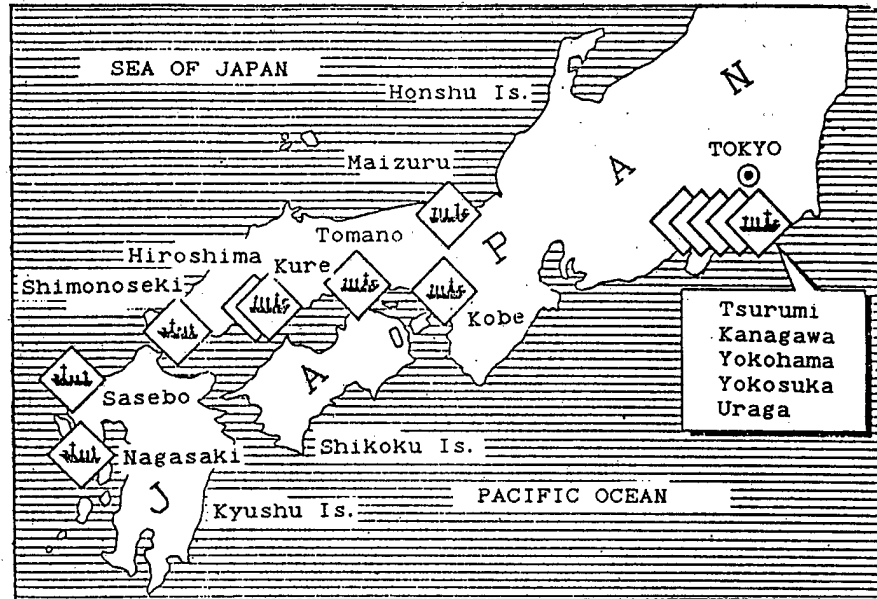

Figure 4. Schematic of the location of Japanese Shipbuilding Enterprises

The company maintains its own technological institute, which performs RTD&E work. It has two trial basins for carrying out speed and maneuvering tests (respective sizes are 160 x 30 m and 60 x 60 m).

In the area of combatant ship construction, the company specializes on DDGs (Nagasaki), diesel submarines at Kobe and patrol and torpedo boats at Shimonosheki. At the factory in Kobe in 1981, they built a self-propelled, habitable, deep submergence vehicle SHINKAI-2,000, capable of a 2,000-m depth. It can be used for military purposes. The company employs 52,300 at its yards.

ISHIKAWAJHIMA-HARIMA JYUKOGE, founded in 1853, is one of the Japanese Navy's largest contractors for combatant ships and auxiliary vessels. More than 15 per cent of the Japanese Navy warships and auxiliaries have been built by this firm. Naval orders are filled in two of their five yards in Tokyo and

Yokohama. Tokyo specializes in the production of DDs and Yokohama in auxiliaries. In 1970, in Yokohama, MITSUI, Japan's first atomic powered ship (fourth in the world), was built (gross capacity of 8,350 GRT), serving as a base for investigation aimed at creating new atomic power plants. The company employs 27,000 people. The firm has five graving docks and eight repair docks, including one floating drydock (capable of lifting 55,000 tons).

MITSUI JYUKOGE, was founded in 1917. It builds DDs, FFs and corvettes for the Japanese Navy. Naval orders are filled at its plant in Tamano, one of four yards, which has two graving docks, permitting construction of ships with deadweight tonnage of up to 140,000 tons, two dry and one floating repair drydock of 80,000-ton lift capacity. The company is experienced in launching destroyers and is the leading Japanese firm in frigate construction.

KAWASAKI JYUKOGE is one of the oldest companies in Japan. It has been building ships since 1896. Almost half of the submarines produced in the country are launched at its yards in Kobe. It also has experience in building destroyers, frigates and corvettes and underseas research equipment. Its test basin (200 x 13 x 6.5 m) is the largest in Japan. Kawasaki has three graving docks and four drydocks (of which two are floating with a lift capacity of 300-13,000 tons).

SHUMITOMO JYUKOGE was established in 1888. Two of the company's four shipbuilding facilities construct warships: in Uraga (in postwar years, they have filled Navy orders for destroyers, frigates, corvettes and cutters); and in Yokosuka (where they build ships up to 500,000 deadweight tons and perform warship repairs on American ships as well). Their yards have one graving dock and two construction and two repair drydocks. Shumitomo employs about 10,000 people.

HITACHI JOZEN, founded in 1881, has built warships since 1900. Its yards have six graving docks capable of building 250,000 deadweight ton ships, and ten repair drydocks, capable of servicing ships up to 400,000 tons displacement. Naval orders are filled in Maizuru (DDs and FFs) and in Kanagawa prefecture (minesweepers).

SASEBO JYUKOGE specializes in large tonnage shipping, including natural gas carriers. Its yard in Sasebo builds tank landing ships for the Navy, from experience gained by building torpedo boats. There they have a construction dock capable of launching up to 350,000 DWT ships, two graving docks and five repair drydocks which can service ships of up to 180,000 tons displacement.

NIPPON KOKAN JYUKOGE was established in 1912. It manages three shipbuilding yards. Naval orders are filled at the yard in Tsurumi (Yokohama) experienced in building corvettes, and which recently has produced more than half of the minesweepers launched in Japan. It boasts two building drydocks and one repair drydock which can accept ships up to 500,000 GRT capacity. In its graving docks, the company has built several auxiliary ships for the Japanese Navy.

The company's laboratory has a test basin of 11,000 m² and speed test channels 750 m long. In 1982, they added a 20x6x2-m test basin which replicated arctic conditions.

Table 3 displays the number of graving docks and drydocks in the Japanese shipbuilding industry. In addition there are about 84 other docks with a lift capability of up to 3,100 tons.

Table 3

NUMBER OF DRYDOCKS AND GRAVING DOCKS IN JAPAN

CAPACITY (GRT) (Lift Capacity, tons)	TYPE	
	CONSTRUCTION	REPAIR
500-4,999	203	110
5,000-29,000	38	61
30,000-99,999	25	22
100,000 and above	10	12
Total	276	205

Japan has no private or government-owned shipyards specializing in warship construction, since the share of defense shipbuilding in the overall volume of ship construction is small and it is disadvantageous for [private] firms to own them. Construction and repair work on warships and auxiliaries is done at normal shipbuilding wharves. The companies in warship construction maintain a group of defense advisors and consultants drawn from a number of former Navy officials. In recent years a kind of specialization has emerged among the shipyards which fill naval orders, DDs are built at the yards of five firms in Nagasaki, Tokyo, Maizuru, Tamano and Uraga; FFs at three yards in Maizuru, Tamano and Uraga; minesweepers in Tsurumi and Kanagawa; and tank landing ships in Yokohama and Sasebo. Two yards in Kobe build submarines.

Wide shipbuilding experience and the availability of highly-productive equipment in many shipyards (even in others not mentioned in this article), in foreign military specialists' opinion, allows the Japanese shipbuilding industry to fill orders for military ships of a variety of classes and to equip them with weapons of indigenous manufacture.

1. Of these, 19 units (3 submarines, 11 DDGs, 4 minesweepers and 1 replenishment ship) remain in various stages of construction, including ships not yet laid down due to interrupted orders.

COPYRIGHT: "Zarubezhnoye voyennoye obozreniye," 1986

9355

CSO: 1801/216

FOREIGN MILITARY REVIEW

NATO MILITARY PIPELINES IN CENTRAL EUROPE

Moscow ZARUBEZHNOYE VOYENNOYE OBOZRENIYE in Russian No 5, May 86 (Signed to press 11 May 86) pp 71-74

[Article by Col V. Elin; "NATO Military Pipelines in Central Europe"]

[Text] The leadership of NATO, following a militaristic course, is conducting a variety of measures for the unjustified unleashing this aggressive bloc's military power, including an all-around improvement of the European theater infrastructure.

Preparation of a system for the NATO armed forces in Europe material supply, one of the most important of which is supplying them with POL, is being carried out intensively. For each branch of the armed forces it is different, but on average, under modern combat conditions, it amounts to 50 per cent of the total material requirement. In particular, foreign military specialists' calculations show that the daily consumption of POL by a U.S. mechanized (armored) division may total more than 650 tons in defense and up to 820 tons in the offense. Even in peacetime, the POL requirements of the NATO armed forces in the early 80s were a minimum of 60 million tons a year.

Pentagon expenditures for purchasing petroleum products for the U.S. armed forces are constantly increasing. If they were 2.9 billion dollars in 1977, and in 1983, they were already 10.3 billion, in 1986, they will reach 12.1 billion. In the FRG in the current year, the Bundeswehr appropriated 960 million marks for the purchase of POL. This tendency is characteristic of the other NATO countries, also. Therefore the North Atlantic bloc's armies' support organizations pay special attention to the transport of petroleum products. NATO experts consider the most rational means for moving POL to be pipelines, which are simultaneously transport resources and a transport route.

The functioning of pipelines which are, as a rule, laid underground is not related to movement conditions on railroads and automotive roads and significantly reduces the load on lines of communication. Their functioning is practically independent of weather conditions or time of day.

NATO believes that pipelines surpass all other ground transport methods in productivity. For example, according to Western specialists' calculations, up to 110 m³ per hour flow through a 152-mm diameter pipeline. During the course

of 18 hours of daily operation, 2000 m³ of petroleum can be delivered which would require 57 railroad tank cars with a capacity of 35 m³ or 100 tank trucks with a 20 m³ capacity. Also, pipelines have such other advantages as alternating flow of different products through the same pipeline, minimizing the transport distance by laying the pipeline along the shortest route, elimination of deadheading back to the distribution point, and reduction in the time for resupplying.

However, as noted in the foreign press, this type of transport does have certain disadvantages: vulnerability to sabotage (since pipelines are almost undefended), and large expenditures of time and equipment to locate damage, which can only be repaired by qualified specialists.

NATO evaluates the negative factors differently for peacetime and war. In the first case, the most common is normal wear and tear requiring a corresponding effort to repair, but in war time you have to add the indefensibility of pipelines. It is believed that the major pipeline net facilities (pumping stations, storage tanks) can be located comparatively easily as a result of their open location. Their coordinates are known ahead of time in most cases.

Considering the military, economic and technical aspects of using pipelines for transporting fuel, the NATO Council adopted a program for developing the military infrastructure which included initiating construction of facilities for providing petroleum to the forces. First they built storage tanks and then began to lay pipelines deep in the ground. As a result, the NATO pipeline network was built covering all of Western Europe. At the present time, there are several major NATO pipelines in Denmark and the northern part of the FRG (in the North European theater), Central Europe (Central European theater) and Italy, Greece and Turkey (in the South European theater).

The Norwegian pipeline is not long but it has several major storage sites for supplying both the army and air force. POL arrives at them from tanker ports.

The Central European Theater system includes more than 600 km of mainline pipelines and related storage tanks.

About 600 km of pipelines are laid through Northern Italy and are designated, mainly, to supply NATO airbases. In addition to storage facilities on the continent, storage has been built on Sardinia and Sicily. NATO pipelines in Greece also have a total length of about 600 km. In Turkey, both a Western and Eastern pipeline have been built, each with a length of about 1,000 km.

The most significant and best developed pipeline network is in Central Europe (Fig. 1). It has a complex configuration, as a result of which it has great flexibility and maneuverability in case of damage to various sections of the mainline, which, in foreign specialists' opinion, ensures the great survivability of the fuel supply system as a whole.

The Central European system includes more than 6,300 km of pipeline, more than 100 mainline pumping stations, and up to 60 storage facilities. The overall storage capacity is almost 1.8 million m³. The pipelines begin at the English Channel, the North and Mediterranean Seas and cross the territories of France,

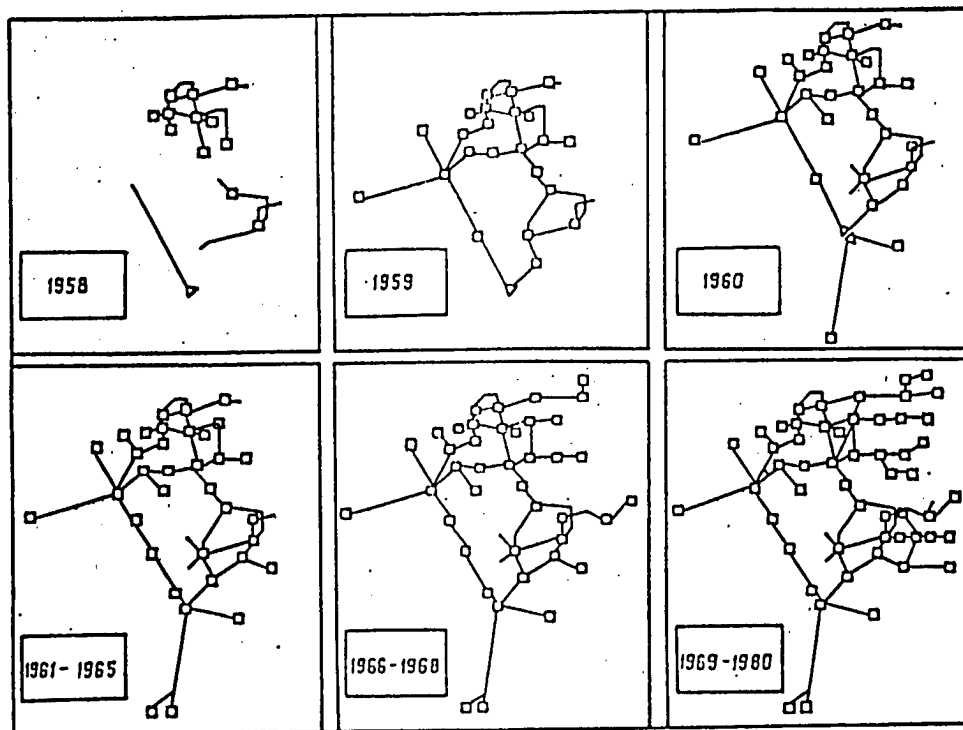

Figure 1. Development of NATO Military Pipeline Nets in Central Europe

the FRG, Belgium, the Netherlands and Luxemburg. To receive petroleum from tankers in Le Havre, Dunkirk, Rotterdam, Lavera and other fixed points are set up. In case these are put out of commission, the possibility of transferring the oil to reserve facilities or unequipped shore points is envisioned.

Pipelines are used to transport aviation and ground vehicle fuel in the FRG where the NATO armed forces are the largest and are equipped with modern weapons and combat equipment and where a number of military bases have been established. The pipeline network, connecting a large number of sea and river ports, railroad stations and about 30 refineries, is relied on to supply fuel to the ground forces and NATO air force during war or peace.

NATO mainline pipelines have pipes of various internal diameters from 152 to 338 mm and are buried in the ground at depths of from 0.6 to 1 m. The pipe diameter decreases as it gets further from the ports and closer to the consumers. Pipes laid under roadways are reinforced with supplemental protective shells. Pipes with extra thick walls are used when crossing water routes. Valves are inserted at determined intervals to permit blocking off damaged sections.

Pumping stations serve to ensure delivery of the fuel with the requisite speed and for overcoming rises in terrain elevation. Most often three consecutive pumping systems raise the pressure to the desired level, usually about 75 atmospheres. Pumping stations have independent sources of energy.

Division of fuels of various types by hydraulic buffers or other means is not carried out. At the present time for this purpose the resultant mixture is collected in a special reservoir and may be added in the proper proportion to gas or diesel fuel.

All technological processes on the line are controlled from the central dispatch control. At has telephone and telex and can issue commands to connect consumers to the pipeline and to shut off branches of the net. Petroleum products enter the net and proceed to destinations in accordance with annual, monthly, weekly, and daily programs. There contain data on priority, place, time, quantity and quality of incoming or outgoing fuel in the appropriate detail.

The largest NATO mainline pipelines include Dunkirk-Canbrai-Reims-Belfort; Amsterdam-Liege-Trier-Karlsruhe; Marseille-Lyon-Langres-Nancy-Zweibrucker; and Donges-Mailain-Chalons. The last belongs to the U.S. armed forces and during peacetime is used exclusively to satisfy their demands.

In support of the armed forces, NATO military pipelines carry jet fuel, diesel and gasoline, chemical and physical matter which correspond to member nation requirements. This makes it possible to put fuel in the system, store, transport, and distribute it to consumers. After checking the quality and quantity of the product entering the system (from this moment it loses its national ownership) the supplier has the right to receive identical fuel in the same quantity at any point(s) in the pipeline system.

The foreign military press notes that one drawback is that this arrangement only exists for military petroleum products since civilian consumers are provided fuel with different characteristics. That means that fuel not used by parties for civilian purposes remains in the lines and can cause delays in transporting military products. Research was conducted to determine if it was possible to use civilian and military fuels closer to each other in quality. NATO experts suggest that commonality between civilian and military fuels may be achieved by 1990.

Besides the five above-mentioned countries whose territory the Central European pipeline crosses, it is utilized by the U.S., Great Britain and Canada to supply their armies and air forces. All eight countries participate in the system's operation and maintenance.

Within the NATO leadership special organizations have been created which are responsible for the operations of military pipelines.

The Central Europe Pipeline Policy Committee consists of civilian representatives of the eight countries who use the pipelines. It oversees the principal aspects of pipeline utilization, develops financial-economic policy, in particular, questions of rates, distribution of fuel, and development of utilization rates and tariffs. The military side of the organization directs utilization of the pipeline in the Central Europe Pipeline Office. Petroleum supply officers from the Armies and Air Forces of the same eight countries are assigned to it and it is headed by the deputy chief of staff for support of the NATO armed forces in Central Europe. The director has overall

responsibility for utilization of the system and carrying out technical policy.

The daily operation of the pipeline system is directed by the Central European Operating Agency which has more than 70 people working in its main office. Seven regional (national) utilization directors have been created for flexible management of the system: three in France, two in the FRG and one each in Belgium and the Netherlands. Each director is responsible for maintenance and repair of the pipelines in his territory, training of service personnel and organization of defense. Altogether there are more than 1,500 personnel in the regional directorates. Within their borders, the countries are responsible for operation of the pipelines but maintenance of the line is paid for by tariffs paid by the fuel consumers.

The NATO military pipeline was built in order to satisfy the sharply increased wartime requirements for fuel. Therefore the full capacity of the system is not used during normal peacetime conditions. Under certain circumstances, the NATO military offices lease the pipelines to civilian oil companies and revenues from this are used for operational expenses. On the whole, as Western specialists note, such proceeds from leasing are not significant, however, on some sections of the line they have grown to significant levels. This also permits training specialists in peacetime to work under conditions of maximum usage of the pipelines.

Besides the military pipelines of the Central Europe system, in this region an international mainline civilian petroleum pipeline network has been built and improved which connects ports with petroleum refining centers. These pipelines are supplemented by local systems. The foreign press notes that in recent years under the aegis of the NATO Central Europe pipeline committee the cooperation in this field between military organizations and oil refining firms has become closer. The process of uniting different systems to increase the possibility of moving resources in the interest of both armed forces and the civilian sector (in particular upon closing of one or more refineries) is underway. It is reported that the question of building a combined military-civilian enterprise is being studied.

In foreign military specialists' opinion, the current systems of military and civilian pipelines, ports and refineries are capable, in the first months of a war, of supplying the NATO armies and air forces in Central Europe without supply from the U.S. or other regions. Additionally, they regard the qualities of the systems of pipelines as a link in the overall chain of fuel supply of forces, believing that uninterrupted supply depends on not only sufficiency of reserves but also on proper organization of delivery to the ultimate consumer.

COPYRIGHT: "Zarubezhnoye voyennoye obozreniye," 1986

9355

CSO: 1801/216

FOREIGN MILITARY REVIEW

NEW VARIANT OF THE TOMAHAWK CRUISE MISSILE

Moscow ZARUBEZHNOYE VOYENNOYE OBOZRENIYE in Russian No 5, May 86 (Signed to press 11 May 86) p 75

[Article by Col I. Karenin; "A New Variant of the TOMAHAWK Cruise Missile"]

[Text] At the present time, the American firm, General Dynamics, on order from the U.S. Navy, is developing a modification of the sea-based BGM-109C TOMAHAWK cruise missile which has been designated the BGM-109D. According to foreign press information, this cruise missile is intended for carrying out strikes on air fields for the purpose of destroying aircraft located both on open hard stands or in special shelters.

In contrast to the BGM-109C, which has a semi-armor-piercing war head, weighing 450 kg, the new missile variant will be equipped with a cassette war head containing as many as 222 subcaliber multiple action BLU-97B bombs. The bomb is a cylinder 10 cm long with a diameter of 6 cm. It contains shaped and incendiary charges, and also prefabricated fragments, which in combination, makes it possible to destroy not only armored and unarmored equipment, but also personnel. The BLU-97B can penetrate about 430 mm of armor. It is reported in the foreign press that the cassette warhead will be made up of separate modules with bombs. In case of necessity, part of the modules will be dismantled and, in place of them, it is planned to install supplementary fuel tanks which will give the missile additional range.

Flight tests of the BGM-109D cruise missile were scheduled to begin at the end of 1985. In case the tests are favorable, it is planned to arm U.S. Navy surface ships and submarines with these cruise missiles.

COPYRIGHT: "Zarubezhnoye voyennoye obozreniye," 1986

9355

CSO: 1801/216

-END-