

# NAVAL POSTGRADUATE SCHOOL Monterey, California



## THESIS

**THE DEVELOPMENT OF A LITTORAL REGION AREA  
COMMUNICATIONS NETWORK IN SUPPORT OF  
OPERATIONAL MANEUVER FROM THE SEA**

By

Bryan J. Smith

September 1998

Thesis Advisor:  
Associate Advisor:

Rex A. Buddenberg  
John Osmundson

Approved for public release; distribution is unlimited.

19981102 126

# REPORT DOCUMENTATION PAGE

Form Approved  
OMB No. 0704-0188

Public reporting burden for this collection of information is estimated to average 1 hour per response, including the time for reviewing instruction, searching existing data sources, gathering and maintaining the data needed, and completing and reviewing the collection of information. Send comments regarding this burden estimate or any other aspect of this collection of information, including suggestions for reducing this burden, to Washington headquarters Services, Directorate for Information Operations and Reports, 1215 Jefferson Davis Highway, Suite 1204, Arlington, VA 22202-4302, and to the Office of Management and Budget, Paperwork Reduction Project (0704-0188) Washington DC 20503.

1. AGENCY USE ONLY (Leave blank)

2. REPORT DATE  
September 1998

3. REPORT TYPE AND DATES COVERED  
Master's Thesis

4. TITLE AND SUBTITLE  
Development of a Littoral Region Area Communications Network in Support of Operational Maneuver From The Sea

5. FUNDING NUMBERS

6. AUTHOR(S)  
Smith, Bryan J.

7. PERFORMING ORGANIZATION NAME(S) AND ADDRESS(ES)  
Naval Postgraduate School  
Monterey, CA 93943-5000

8. PERFORMING ORGANIZATION REPORT NUMBER

9. SPONSORING / MONITORING AGENCY NAME(S) AND ADDRESS(ES)

10. SPONSORING / MONITORING AGENCY REPORT NUMBER

11. SUPPLEMENTARY NOTES

The views expressed in this thesis are those of the author and do not reflect the official policy or position of the Department of Defense or the U.S. Government.

12a. DISTRIBUTION / AVAILABILITY STATEMENT  
Approved for public release; distribution is unlimited.

12b. DISTRIBUTION CODE

13. ABSTRACT (maximum 200 words)

Despite the apparent abundance of modern communication technology such as satellites, computers, and fiber-optic transmission systems, communication capacity is a limited resource for littoral operations. The Navy and Marine Corps lack the dedication to support such doctrinal concepts as Operational Maneuver From the Sea (OMFTS). One solution is to develop a Littoral Region Area Network (LRAN). The primary goal of this thesis is to underscore the littoral operating environment and bandwidth requirements. It also investigates reliable-seaborne network communication systems complementary to satellite and wireless networks, and proposes an open, standards-based modular architecture, utilizing a network-centric design process as the basis for LRAN. It employs modeling and simulation techniques to demonstrate coupling of the system integration processes with the doctrinal concepts of OMFTS.

14. SUBJECT TERMS  
Networks, Satellites, Aerostats, Littorals, Operational Maneuver From the Sea (OMFTS), Communications, Modeling and Simulation, IEEE 802.11, ADNS, Marine Corps Tactical Data Network

15. NUMBER OF PAGES  
163

16. PRICE CODE

17. SECURITY CLASSIFICATION OF REPORT  
Unclassified

18. SECURITY CLASSIFICATION OF THIS PAGE  
Unclassified

19. SECURITY CLASSIFICATION OF ABSTRACT  
Unclassified

20. LIMITATION OF ABSTRACT  
UL



Approved for public release; distribution is unlimited

**THE DEVELOPMENT OF A LITTORAL REGION AREA  
COMMUNICATIONS NETWORK IN SUPPORT OF OPERATIONAL  
MANEUVER FROM THE SEA**

Bryan J. Smith  
Major, United States Marine Corps  
B.S., University of Arizona, 1982

Submitted in partial fulfillment of the  
requirements for the degree of

**MASTER OF SCIENCE IN INFORMATION TECHNOLOGY MANAGEMENT**

from the

**NAVAL POSTGRADUATE SCHOOL  
September 1998**

Author:

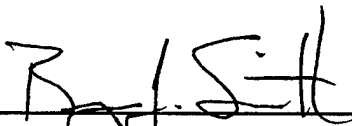
  
\_\_\_\_\_  
Bryan J. Smith

Approved by:

  
\_\_\_\_\_  
Rex A. Buddenberg, Thesis Advisor

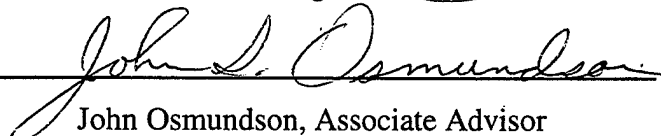
  
\_\_\_\_\_  
John Osmundson, Associate Advisor

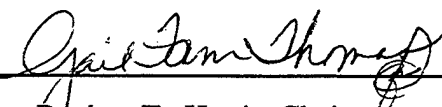
  
\_\_\_\_\_  
Rueben T. Harris, Chair  
Department of Systems Management



## ABSTRACT

Despite the apparent abundance of modern communication technology such as satellites, computers, and fiber-optic transmission systems, communication capacity is a limited resource for littoral operations. The Navy and Marine Corps lack the dedicated networks to support such doctrinal concepts as Operational Maneuver From the Sea (OMFTS). One solution is to develop a Littoral Region Area Network (LRAN). The primary goal of this thesis is to underscore the littoral operating environment and bandwidth requirements. It also investigates reliable seaborne network communication systems complementary to satellite and wireless networks, and proposes an open, standards-based modular architecture, utilizing a network centric design model as the basis for LRAN. It employs modeling and simulation techniques to demonstrate coupling of the system integration processes with the doctrinal concepts of OMFTS.



## TABLE OF CONTENTS

I. INTRODUCTION .....	1
A. PURPOSE OF THESIS .....	1
1. Overview .....	1
2. Littoral Doctrine .....	1
3. Operations in The Littoral Regions .....	2
4. Littoral Employment Scenarios .....	2
5. Ship-to-Objective Maneuver (STOM) .....	3
6. Scope of thesis .....	4
B. RESEARCH METHODOLOGY AND ORGANIZATION .....	5
1. Research Methodology .....	5
2. Organization .....	6
II. LITTORAL DOCTRINE .....	9
A. MARITIME STRATEGY .....	9
1. The Shift in Naval Strategy .....	9
2. Focus on The Littoral Regions .....	10
B. LITTORAL REGION CONFLICT .....	10
1. Historical Precedent for Littoral Doctrine .....	11
2. Strategic Pause .....	12
3. Execution of Ship-to-Objective Maneuver (STOM) ....	13
4. Sea Based Logistics .....	13
5. Littoral Network Communications .....	15
6. Characteristics of LRAN Technology .....	17
III. NETWORK-CENTRIC ARCHITECTURE .....	21
A. NETWORK ARCHITECTURE .....	21
1. Architecture .....	21
2. Open Standards and Open Systems .....	21
B. NETWORK CENTRIC DESIGN .....	23
1. Network Centric Warfare Theme .....	24
2. Network Centric Design Approach to LRAN .....	25
C. SUPPORTED UNITS .....	27
1. Amphibious Ships .....	27
2. Marine Air-Ground Task Force (MAGTF) .....	27
3. Marine Expeditionary Force (MEF) .....	28
4. Marine Expeditionary Unit .....	29
5. MAGTF Over-The-Horizon Communications Capability ..	30
IV. EXISTING TECHNOLOGY .....	33
A. TRENDS AND REQUIREMENTS .....	33
1. DOD SATCOM Functional Requirements Document (DSFRD)	34
2. SATCOM Shortfalls .....	34
3. Future SATCOM Systems .....	36
4. Initial Bandwidth requirements for LRAN .....	39
B. MAGTF BANDWIDTH REQUIREMENTS .....	41
1. Initial Mission Support .....	41
2. MEU Requirement .....	42



3. MEF Requirement .....	44
4. MAGTF Shortfalls .....	48
5. Marine Corps Tactical Data Network .....	49
6. Fiber Distributed Data Interface (FDDI) .....	49
7. Range of TDN Services .....	55
V. EMERGENT TECHNOLOGY .....	57
A. WIRELESS NETWORK STANDARD .....	57
1. Wireless Systems .....	59
2. Wireless Network Architecture .....	60
3. NTDR Tests .....	61
4. Employment Options .....	62
B. AUTOMATED DIGITAL NETWORK SYSTEM (ADNS) .....	63
1. Characteristics .....	64
2. ADNS Architecture .....	64
3. Component Mix .....	65
4. TDN and ADNS .....	69
C. SEABASED AEROSTAT INFORMATION LINK .....	72
1. Technology Background .....	72
2. Principle SAIL Technologies .....	72
3. Technology Base .....	74
4. LOS Over-The-Horizon Communications .....	78
5. Altitude Versus Cost .....	81
6. SAIL Selection .....	85
7. Undersea SDFO Costs Versus Aerobuoy Relays .....	86
8. Aerobuoy Relays vs. Undersea SDFO Cable Links .....	89
9. SAIL Concept of Operations .....	92
D. SYSTEM INTEGRATION .....	93
VI. SUPPORTED CONCEPT OF OPERATIONS .....	95
A. OMFTS SCENARIOS .....	95
1. Network Architecture for The Assault Phase .....	95
2. LRAN Architecture for Sustaining OMFTS .....	96
3. LRAN Architecture for Command and Control Ashore ..	99
VII. LRAN MODELING AND SIMULATION .....	103
A. MODELING AND SIMULATION .....	103
1. Background and Terminology .....	103
2. Software .....	105
3. Design Steps .....	106
B. THE EXTEND MODELS .....	107
1. Design Parameters .....	107
2. System Decomposition .....	108
3. Simulations for Sea Based Command and Control .....	109
4. Sea Based Command and Control Simulation Results ..	112
5. Conclusion of Simulation Results. ....	115
6. The Marine Corps TDN and ADNS Model. ....	117
VIII. CONCLUSIONS AND RECOMMENDATIONS .....	119
A. SUMMARY .....	119
B. AREAS FOR FUTURE RESEARCH .....	121

C. CONCLUSION .....	122
APPENDIX A MARITIME STRATEGY .....	125
1. Littoral Geography .....	125
2. The Law of The Sea .....	126
3. Maritime Disorder .....	127
4. Near-Land Employment of Naval Forces .....	127
APPENDIX B NETWORK TERMINOLOGY .....	129
1. Local, Metropolitan, and Wide Area Networks .....	129
2. Network Standards .....	130
3. Common Interfaces .....	134
4. Network Performance .....	135
5. Network Delay .....	136
6. Data Flows and Applications .....	137
APPENDIX C EXTEND MODELS .....	139
LIST OF REFERENCES .....	147
INITIAL DISTRIBUTION .....	151

## I. INTRODUCTION

### A. PURPOSE OF THESIS

This thesis serves to facilitate interest in the conceptual study and emphasis on development of a Littoral Region Area Network (LRAN) to support over-the-horizon (OTH) communication requirements for Naval Expeditionary Force (NEF) operations and U.S. Marine Corps doctrine Operational Maneuver From The Sea (OMFTS). The research will discuss and analyze communication and technology requirements associated with design of an open standard based network to support OMFTS and NEF operations from standoff distances in excess of 200 nautical miles of coastal regions.

#### 1. Overview

The United States Navy and Marine Corps concept for naval power projection ashore in the world's littoral regions is articulated in the Navy-Marine Corps white paper "Forward...from the Sea" and "Operational Maneuver from the Sea," (OMFTS). [Ref. 1 and 2]

#### 2. Littoral Doctrine

The Navy and Marine Corps documents "Sustained Operation Ashore," and "Sea Based Logistics" further explain doctrinal support concepts in the littoral environment. [Ref. 3 and 4] Each specify the several traditional naval roles and missions associated with maritime supremacy, but

also emphasize the readiness to conduct naval operations in littoral regions throughout the world.

### **3. Operations in The Littoral Regions**

The themes in the previous referenced doctrinal concepts are characterized by the requirement for enhanced command and control systems; increased computing and communications power and capability; aggressive intelligence and surveillance systems that provide a complete picture of the operating environment coupled with robust logistic support systems. [Ref. 1 and 4] When well orchestrated in this environment; the above are intended to act as a force multiplier in the prosecution of littoral operations against a hostile aggressor. These imply a connection between operational maneuver of tactical forces ashore and total synchronization of logistics support during these actions.

### **4. Littoral Employment Scenarios**

It is possible to influence events in these regions by projecting power over littoral water with the use of carrier based aircraft and land attack cruise missiles, thus avoiding the need to operate in them. However, if logistic support from the sea is required to sustain a land campaign, or if amphibious forces are required to conduct a landing, naval forces must be prepared to transit and operate in the littorals, plus provide sustained support. This means they must be prepared to defend against specific littoral region threats. This concept is emphasized specifically in OMFTS,

where potential adversaries in the littoral regions will possess inexpensive, advanced weapon and sensor systems that will make traditional amphibious methods of ship-to-shore movement and lodgment more risky than the past.

### 5. Ship-to-Objective Maneuver (STOM)

To reduce this vulnerability, OMFTS requires swift, direct to the shore movement to objectives inland, without

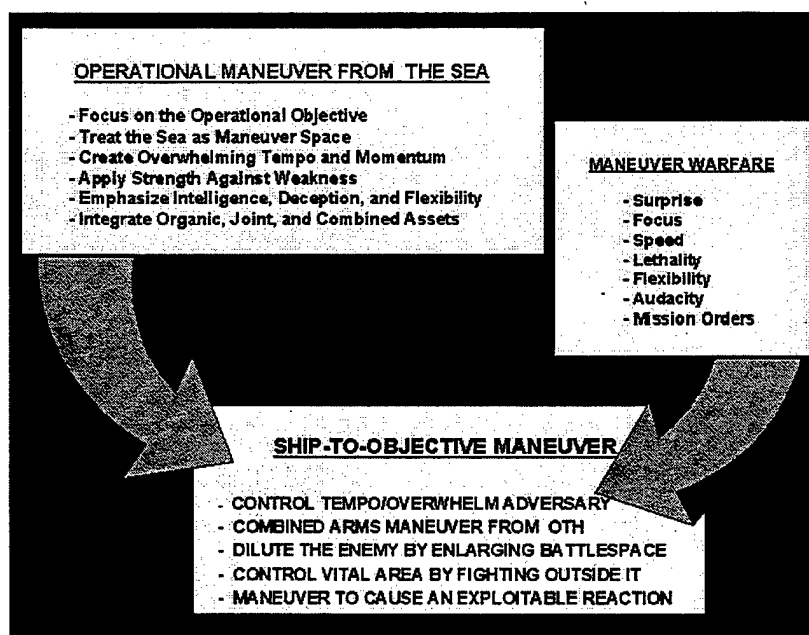

Figure 1.1. Ship-to-Objective Maneuver. [Ref. 5]

pause or build-up on a beachhead. The associated term for this is Ship-to-Objective Maneuver (STOM). Execution of STOM requires that assault forces must be lighter, and faster than the past. Command, control, communications, and intelligence surveillance reconnaissance systems (C4ISR), combat service support (CSS) and fire support (naval surface

and close air) must be sea based. The general characteristics of STOM are portrayed in Figure 1.1. [Ref. 5]

## **6. Scope of thesis**

This thesis is a concept study that presents LRAN requirements, architectural design considerations for over-the-horizon communications in the littoral region, and proposes three network architectures developed through a PC based network design tool emulating available technologies. The simulation models represent a cost-effective design effort to support the technical viability of the concepts presented in this study. It is also intended to initiate further testing and evaluation of current and future technologies associated with developing LRAN. This thesis examines the following research questions:

1. Define LRAN. What solutions does it offer toward doctrinal debates surrounding NEF operations in the littoral regions?

2. What are the forces afloat and ashore bandwidth requirements to conduct operations within the littoral regions such as the Marine Corps OMFTS concept?

3. What are the possible LRAN employment schemes necessary to support littoral operations and their associated technology tradeoffs?

4. How can modeling and simulation techniques assist in determining overall LRAN design requirements?

This thesis is limited to reviewing and analyzing NEF and OMFTS doctrine, and reviewing existing as well as potential technology candidates that would comprise an LRAN model. It assumes the reader has basic working theory knowledge of network terminology, and is conversant in the area of study. A basic review of required network terminology applicable to the concepts discussed in this thesis is provided in Chapter three. However, basic computer network textbooks written by Comer, and Tanenbaum can provide additional background and understanding regarding these areas. [Ref. 6 and 7]

## **B. RESEARCH METHODOLOGY AND ORGANIZATION**

### **1. Research Methodology**

This research was initiated to assist part of an ongoing Advanced Concept Technology Demonstration (ACTD) project in over-the-horizon (OTH) communication systems funded by the Operations of Naval Research (ONR) and executed by the Naval Facilities Engineering Service Center (NFESC) in Port Hueneme, California. The sources of information were literature searches through Department of Defense (DOD) publications in full or draft form, the thesis section at the Dudley Knox library at the Naval Postgraduate School, and interviews with subject matter experts throughout DOD. It will investigate how LRAN would support a littoral C4I architecture. This includes investigation of

both existing, and developmental systems such as wireless radio networks, and undersea small diameter fiber optic cable (SDFO) coupled with airborne aerostat technology.

Trips were also taken to development locations to confer and gain undocumented information with those organizations, activities and personnel developing the various systems discussed in this thesis. The visits included open discussion with subject matter experts and observations.

## **2. Organization**

This thesis is organized as follows:

### **a. Chapter II**

This chapter discusses changes in U.S. naval maritime strategy, the emergent doctrine supporting NEF operations in the littoral regions, and introduces the command, control and communications problem associated with conducting naval operations in this environment.

### **b. Chapter III**

This chapter defines LRAN; discusses an open standards architecture approach to LRAN design as a precursor to understanding the network centric paradigm. It also reviews basic networking terminology to aid in understanding LRAN concepts.



**c. Chapter IV**

This chapter discusses the principles and details supporting existing technology and communication systems and their network interfaces employed as part of LRAM.

**d. Chapter V**

This chapter discusses the details of emergent technology and communication systems and their network interfaces employed as part of LRAM.

**e. Chapter VI**

This chapter presents a proposed concept of operations for the employment of a LRAM based on Navy and Marine Corps littoral doctrine.

**f. Chapter VII**

This chapter discusses the design and technique of employing personal computer (PC) based modeling simulation tool to model the baseline LRAM system to support OMFTS, and intended employment schemes, based on exercise concept of operations proposed for the future U.S. Marine Corps Warfighting Lab, exercise scenarios.

*g. Chapter VIII*

This final chapter presents and discusses the final conclusions drawn from the research and provides important recommendations for further study in this area.

## II. LITTORAL DOCTRINE

### A. MARITIME STRATEGY

U.S. Maritime Strategy is derived from objectives and guidance established in U.S. National Security Strategy and U.S. National Military Strategy. Its aim is to provide a framework from which planning and decisions regarding naval roles, mission and force structure are formulated [Ref. 8]. From this, traditional naval strategy has often centered on either defending battle groups or amphibious ready groups as in the Cold War.

#### 1. The Shift in Naval Strategy

However, with the collapse of the Soviet Union in 1991, the cold war, which so dominated world politics was over. With it came a change in the international security environment and subsequent changes to the previous mentioned documents. It soon became apparent that this shift in policy would have profound implications for the Navy and Marine Corps, that eventually led to the emergent doctrinal concepts such as "From...The Sea", and OMFTS. Unfortunately, the dynamic aspects of ship-to-objective maneuver in littoral operations has partly been neglected, and is now receiving attention with respect to various type communication systems and delivery systems that support littoral battle doctrine. By its nature naval maneuver and

maneuver in general implies a displacement of assets and resources. In addition maneuver implies the expending of resources to accomplish it; therefore, it is necessary to discuss operational maneuver, and sustainment in the same context.

## **2. Focus on The Littoral Regions**

In *The Prince*, Machiavelli wrote that, "there is nothing more difficult to carry out nor more doubtful, nor more dangerous to handle, than to initiate a new order of things..." [Ref. 9]. Four centuries later, this statement couldn't be truer. In light of the changes to international security environment new questions arose regarding U.S. Naval Maritime strategy. What emerged was a focus toward regional challenges, opportunities, and instability, where change is widespread and unpredictable [Ref. 10]. The impact of this change was the result of such factors as littoral geography, the United Nations Convention on the Law of The Sea, Maritime Disorder, and studies conducted to account for instances of naval forces employed near land. A more in-depth, precise analysis of these areas is provided for review in Appendix A.

### **B. LITTORAL REGION CONFLICT**

United States Naval Forces provide sea control; power projection and forward presence is a common and accurate historical truism. In general, naval combatants are

principally focused on positioning and maneuver to enhance delivery of goods and services throughout a broad spectrum of potential crises. Accomplishing this requires security and control of the seas and littoral regions.

#### **1. Historical Precedent for Littoral Doctrine**

The United States Navy and Marine Corps is presently in a position highly analogous to that of Britain in the 1800's after defeating Napoleon in the battle of Waterloo. During this period the Royal Navy employing cunning maneuver, decisively defeated the combined Spanish and French fleet in the open sea battle near the coast at Cape Trafalgar near Cadiz, just North of the straight of Gibraltar. What followed was the absence of an open-ocean challenge to the Royal Navy's sea power. And one would not materialize until almost a century later when Germany's Tirpitz reached the German Naval Ministry and convinced the Chancellor, Wilhelm II to build a combatant high seas fleet.

On the occasion of minor skirmishes during this period, virtually every Royal Navy exercise was in direct support of the forces ashore that were deployed in early stages of potential crises to help maintain political and economic stability within Britain's world interests. Each of these incidents involved sea based units capable of providing adequate support to lightly armed forces ashore at close standoff distance from a beach or port.

The basis of OMFTS doctrine in support of NEF operations has similar characteristics associated with the one above historical example. It has the primary characteristic of reducing strategic pause. This is characterized by reducing or completely eliminating the logistics build-up and beachhead lodgments unique to past historical examples. [Ref.1]

## **2. Strategic Pause**

The island hopping campaigns during World War II in the War in the Pacific represents an example of strategic pause. The Marine infantry and aviation units were not deployed in combat without combat service support (CSS) units to sustain and support them ashore. Contrary to this, OMFTS implies that assault forces from ships at sea, without pause, maneuver directly to designated objectives inland. Speed and velocity of maneuver are the key elements of surprise. Therefore, the assault forces must be lighter and faster than they are now to accomplish this goal.

In theory, the swift application of force has a subsequent result of reducing threat, or hostile action. A simple analogy to this is the small local fire department whose aim is to quickly arrive at a fire (the threat), and suppress it as quickly as possible (the force). This is because a small fire is easier to extinguish than one that is raging out of control.

### **3. Execution of Ship-to-Objective Maneuver (STOM)**

According to U.S. Marine Corps Ship-to-Objective Maneuver (STOM) doctrine, a Naval Expeditionary Force would employ such future available assets as the MV-22 Osprey, the Advanced Amphibious Assault Vehicle (AAAV), and the Landing Cushion Assault Craft (LCAC) from seaward to landing points ashore. The MV-22 travels at speeds of 200 plus knots; the AAAV at 30 plus knots; and the LCAC at approximately 60 knots, with light loads.

### **4. Sea Based Logistics**

Sea base support incorporating the above delivery systems demands significant changes in the way NEF forces communicate and execute logistics support operations. This concept, known as Sea Based Logistics, asserts that logistics capabilities remain sea based where they can rapidly maneuver with seaward maneuver forces. Successful accomplishment requires four inherent characteristics:

#### **a. Command and Control (C2)**

Logistics operations are provided from a seaward base where ordinarily in the past it would focus around a base of operations ashore. This requires networked C2 structures that openly share logistics information across different communication mediums, but operate concurrent, or share the same network with other tactical systems.

**b. Reliability**

Logistics demand is reduced based on improved operating methods, material reliability, and autonomous information reporting systems.

**c. Speed**

Sea based logistics requires in-stride sustainment to maneuver units ashore coupled with highly automated procurement and distribution management systems that reduce human input, accelerate material movement and reduce costs.

**d. Flexibility**

Retain the ability to smoothly transition to joint and land based operations as required by the National Command Authority.

In general, this concept is not entirely new to forward-deployed Carrier Battle Groups, or the deep-water navy as a whole. The Sea Base Logistics concept is a method or means to greatly expand the scope of support from the sea, to the littoral region, and forward to operations ashore. Historically, deep water Navy vessels have relied on sustainment from floating re-supply ships, which receive their stores from shore, based installations. This is an eventful process at sea especially when faced with unfavorable environmental conditions.

The geography and environment in the coastal regions has a great impact on distribution techniques. In addition,



equipment accountability becomes difficult as units move from a forward, deployed sea base and disperse to multiple objectives inland ashore. Providing an excessive supply build-up ashore only can hinder an assault forces ability to maneuver, or adapt to a dynamic, changing tactical situation. When decreasing the logistics build-up ashore, reliable sea base re-supply systems must be in place at safe protective distances of 100-200 nautical miles from shore. They will depend heavily on unit status reporting and accountability running on top of networked communications systems to the extent units can be quickly re-supplied with the intended requirements in a timely and reliable manner. There are many examples of this in commercial industry to include FEDEX, CTX Railways, and Levi-Strauss.

#### **5. Littoral Network Communications**

The command, control, communications, computers, and intelligence features organic to maneuver units executing OMFTS, and in particular, sea base logistics will require voice, data, and imagery transmission capabilities networked to interface with heterogeneous communication systems that act to enhance in-stride sustainment of the maneuver elements ashore, and provide operational support. Most important to this concept, these capabilities must span the full continuum of engagement, to include the introduction of light, mobile forces ashore; to increased levels of conflict, requiring the presence of a command and control

infrastructure ashore as well as aboard sea based shipping. In the past, Marine command and control support from shipboard communications assets have always been minimal, anticipating an eventual build-up of the traditional robust ground force infrastructure following a landing ashore. In the sea based OMFTS environment, command and control must consider operations exclusively from at sea. As a result, this places a significant burden on the communication infrastructure of sea based units. Subsequently, a great deal of the command, control, communications, computers, and intelligence (C4I), combat service support, and fire support must reside there. The by-product of this would be a comprehensive tactical picture (including the logistics data component) that allows resource distribution in a timely and efficient manner.

a. ***Ship-to-Shore Communications of NEF Forces executing OMFTS and Sustaining Forces Ashore***

Naval C4I systems are "the information systems, equipment, software, and infrastructure that enable the commander to exercise authority and direction over assigned forces." [Ref. 12]

C4I systems need to facilitate information flow throughout the force, not just up and down the chain of command. Their design should be from the user or ground up as part of an architecture that can easily integrate with other operational systems.

**b. Limited Bandwidth**

During the first Navy-Marine Corps Naval Expeditionary C4ISR Requirements Conference discussion focused on the limited communications bandwidth available between forces ashore and afloat. It was here that both services agreed there should be a baseline standard for secure voice, video, and data communications. [Ref. 11] In periods of hostilities, it is predicted that existing communication systems will be dedicated primarily to support tactical data transmissions [Ref. 12].

The equipment to make the needed transition from communication nets to information networks has already been developed. [Ref. 1] The Navy and Marine Corps lack the dedicated network systems necessary to support these advances in support of OMFTS, but both services are in a position to take advantage of this new technology. LRAM is one such solution, and serves as the principle network foundation or backbone for the future design of an integrated network, littoral communication system.

**6. Characteristics of LRAM Technology**

An intended primary characteristic of LRAM technology would be that it is rapidly deployable, low-cost, and would form a dedicated communications link that would complement and/or parallel radio and satellite communication technologies. The U.S. Navy Space Warfare Systems Command (SPAWAR), and the Naval Facility Engineering Service Center

(NFESC), Port Huenume, California are responsible for advanced technology concept development for systems that are discussed later in chapter four of this thesis. The author participated in the initial system requirements analysis and preliminary system design and development.

In network parlance, LRAN is envisioned to provide a multiple path information network between forces ashore and sea based shipboard units. It would serve as a reliable and autonomous communications link for passing operational as well as logistics data in support of OMFTS. In addition, it has the potential to expand to serve in a sensory mission by protecting sea lanes and maneuver space within the littoral region. In summary, the system would provide:

- Multiple path backbone for high bandwidth communications in support of naval expeditionary units located up to 200 NM from seaward to shore.

- A dedicated, reliable secure network link capable of supporting status and position reporting, logistics concepts such as Total Asset Visibility (TAV), including automated and semi-automated accounting of personnel and material assets ashore and afloat. Applications are intended to be interoperable with the Global Command and Control System (GCCS).

- Direct links between logistics and operational

planning and decision support.

- Real-time interface for immediate requirements dedicated to maneuver units ashore.
- Form a surface, undersea sensor grid within the littoral region to detect and account for threat mines, undersea craft, and other shallow water threats.

The littoral operating environment will be inhibited by a physical environment unique to the littoral region and an adversary who will likely endeavor to attack transportation and information resources required to support the sea base concept. Therefore, it is imperative LRAN exhibits modular system qualities. Divided into multiple decision rule based sensors, processors and communications networks that are attached through open interfaces to the network, that provides multiple paths from one end user to another. Their function is to aid users in decision processes. What follows in the next chapter is a basic discussion and background on standards based network centric design and the rationale behind open systems.



### **III. NETWORK-CENTRIC ARCHITECTURE**

#### **A. NETWORK ARCHITECTURE**

##### **1. Architecture**

A general definition of an "architecture" is defined by IEEE STD 610.12 and the C4ISR Integration Task Force as: "the structure of components, their relationships, principles and guidelines governing their design and evolution over time." [Ref. 13]

Communications Architecture should consist of separate but related pieces that can be combined with a minimum amount of tailoring, so that they can be used for multiple purposes. They represent a current or future point in time, of a defined "domain" in terms of its component parts, what those parts do, how the parts relate to each other, and the rules and constraints under which the parts function.

##### **2. Open Standards and Open Systems**

Formally documented and accepted standards and guidance provide the fundamental elements necessary to allow the components of a network architecture to be interoperable as an open system. An open system network built to standards provides creditability and trust by users for usage and reliable operation. The metaphor used in the Joint Technical Architecture (JTA) describes standards as the "building code." Unlike a building infrastructure, which is totally

based on physical principles, a network must complement the logical information infrastructure, and retain the needed discipline to support the logical environment as well as survive the physical. [Ref. 14] In addition, a network needs to be responsive to information demand and technology advancements, so that it can evolve over time with minimal loss of service, but with improved performance as the result of these advancements.

Open standard networks incorporate technologies based on readily available published specifications for use, in order to make it easier to establish a connection or to communicate. As a result, they are nonproprietary and supported my commercial industry. Open standards also promote competition in the market place, and encourage growth.

An open system describes products and technologies that have been designed and implemented according to open interfaces. An interface is defined as a connection between two devices that is implemented to communicate with one another and other systems. They are considered open if their specifications are readily available and applied to technology. In short, multiple commercial organizations, vendors, users, and suppliers accept, adopt, and implement open standards for open systems that support common interfaces for local, metropolitan, and wide are network infrastructure. Further discussion regarding protocols,



network infrastructure, standards organizations, and general definitions regarding network data flow, performance, and delays, along with a description and definition of common network interfaces is provided in Appendix B. A general background information in the above areas will aid in understanding the following information on the network centric design approach to LRAN.

#### **B. NETWORK CENTRIC DESIGN**

The foundation for future joint warfighting is described in Joint Vision 2010 (JV 2010). JV 2010 introduces the emergent operational concepts of Dominant Maneuver, Precision Engagement, Focused Logistics, and Full-Dimensional Protection, as well as enabling capability of Information Superiority. The popular observation is that the operational concepts above can be enabled by operational network architectures that closely couple the capabilities of sensors, command and control and shooters. Consequently, the emerging operational concepts of JV2010 can be characterized as network centric and the vision of future warfare described in JV 2010 as network centric warfare.

[Ref. 15]

This is a derivative of network centric computing. The evolution of computing from platform centric computing to network centric computing has been largely enabled by recent key developments in information technology. Some of the most

important developments in information technology include Hypertext markup Language (HTML), web browsers, and TCP/IP. These developments make it much easier for computers with different operating systems to interact with each other.

As a follow on to this, interoperable systems can be built in increments allowing upgrades, and new technology insertion as it becomes available.

In discussing network centric warfare, the Commander in Chief of U. S. Naval Space Warfare Systems Command, VADM Cebrowski states: "Network-centric warfare and all of its associated revolutions in military affairs grow out of and draw their power from the fundamental changes in American society. These changes have been dominated by the co-evolution of economics, information technology, and business processes and organizations." [Ref. 16]

#### **1. Network Centric Warfare Theme**

The central theme to network centric warfare is the shift in focus from the single autonomous platform to an integrated network approach.

As such, the network becomes the linkage of all participants so that they all see the same information at the same time and command decisions can be made jointly and in real time, thereby achieving speed of command.

In this spirit, the development of LRRN technology embodies the network centric paradigm. It crosses service boundaries between the Navy and Marine Corps with focus on

supporting the operational transitions of OMFTS. The physical or environmental transition is from over the horizon at sea, which reach inland to support mobile fighting forces ashore. It must also be adequate to support the proliferation of joint users as well as coalition forces.

## **2. Network Centric Design Approach to LRRAN**

The LRRAN network focus is on supporting an infrastructure composed of sensors and decisions support processes that support disintermediate type organizations with flat organizational structure. For example, in OMFTS, it is apparent that various size units such as a four-man infantry fire team to an Infantry Company of approximately 150 Marines require access to the network based on the criticality of their mission. And also require and pass similar types of information. Furthermore, in the ever-changing world security environment of today, requirements are difficult to translate into immediate needs, at a pace commensurate with the world events. A network centric system controls the risk associated with misstatement of the requirement. For example, the network centric view allows us to scale networks toward levels of high system integration (or scale down) in ways not conceived in the original design. This can be accomplished with both commercially and government only available components if properly

implemented. Given the rate of technological advance, this is an attractive quality of the network centric paradigm.

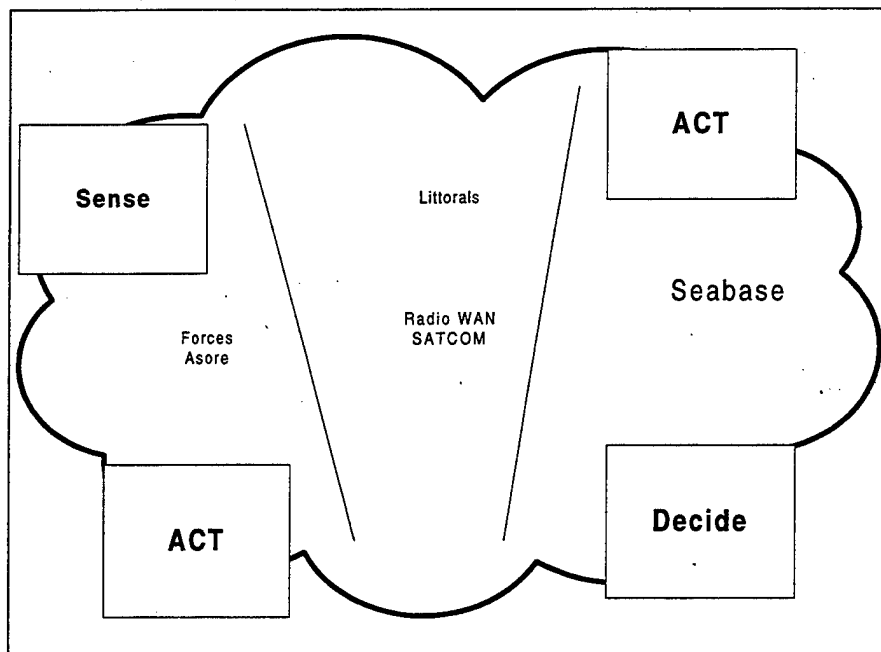

Figure 3.1. LRAN Network Centric Design.

Figure 3.1 portrays this concept in a general fashion. The network centric approach avoids the temptation to build the system around any central component where failure or obsolescence would require replacing the entire system. Instead the network itself is used to eliminate bottlenecks, single points of failure, and serial connectivity. Modular architectures are flexible, scalable, and reliable and have improved performance as the network expands and builds. High availability is not inherent to the network; it has to be built with this characteristic in mind.

Consequently, If one node of the system fails the entire network is not subject to failure. Thus availability

remains high. Interoperability is achieved when information or services can be exchanged directly and satisfactorily between systems. System connectivity provides supported users access to the timely transmission of imagery, video, voice and data in peace, crisis, conflict, humanitarian support, and war.

### **C. SUPPORTED UNITS**

The purpose of the following sections is to describe the supported units that benefit from technology incorporated in to the LRAN system.

#### **1. Amphibious Ships**

The U.S. Navy "L" class amphibious ship or grouping of these ship forms the nucleus of the sea base platform for NEF operations. These ships traditionally deploy as part of an Amphibious Squadron of usually four to five ships, (PHIBRON) or an Amphibious Ready Group (ARG) of twelve to fifteen ships. Extremely flexible, these ships exhibit a tremendous operational and logistics capability to prosecute surface and air operations in the littoral regions.

#### **2. Marine Air-Ground Task Force (MAGTF)**

During conflicts, the Marine Corps forms self-sustaining fighting organization whose size is dictated by their assigned task. These task-organized units are called Marine Air Ground Task Forces (MAGTF, pronounced "mag-taff"). The MAGTF traditionally deploys aboard U.S. Navy "L"

class amphibious ship. Each MAGTF consists of a ground combat element (GCE), air combat element (ACE), combat service support element (CSSE), and command element (CE). Infantry, artillery, and armor units make up the GCE; fixed and rotary wing aircraft and their supporting units comprise the ACE; logistics, engineer, communication and other support units fall under the CSSE; the commander and his staff are the command element. The ground, air, and combat service support elements of a MAGTF are often referred to as major subordinate commands (MSC's) as shown in Figure 3.2. [Ref.17]

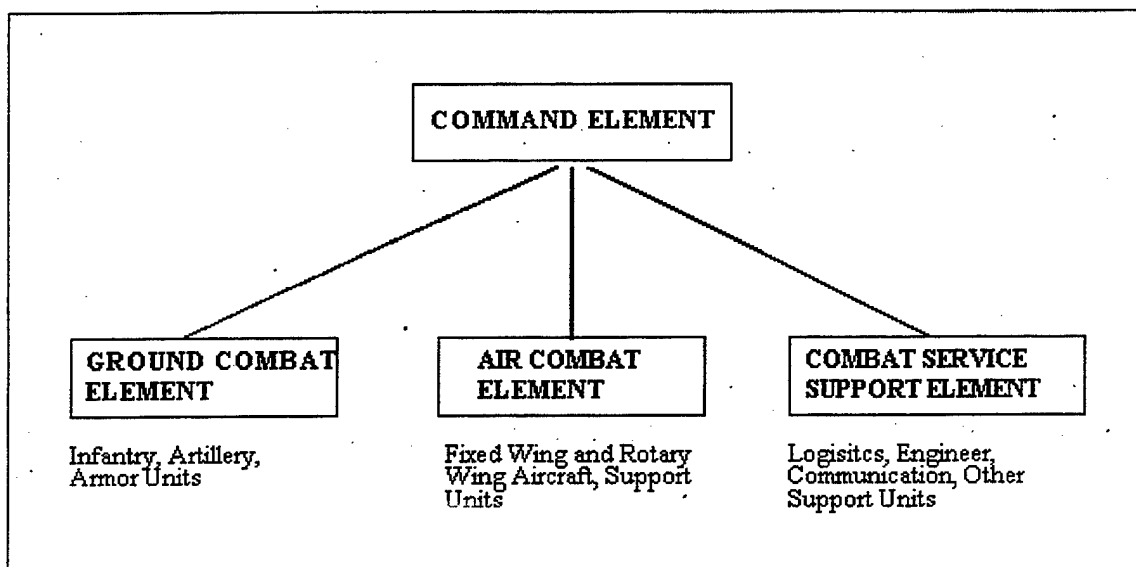

Figure 3.2. The USMC MAGTF Concept.

### 3. Marine Expeditionary Force (MEF)

The largest task force that can be organized is called a MEF. The units that flesh out each element of the MEF are the largest of their type. In total, the MEF is

approximately 18,000 to 20,000 Sailors and Marines. The MEF GCE is staffed by a Division, the largest combat unit in the Marine Corps. Each Division consists of the infantry, artillery, and armor units mentioned earlier. Similarly, a Wing forms the ACE, while a Force Service Support Group (FSSG) makes up the CSSE. The appropriate size staff commands the MEF. For conflicts, which require more lethality than a single MEF, more than one, MEF can be deployed.

Piecing together elements further down in the organizational hierarchy can form smaller sized MAGTF's. For example, the next smaller MAGTF is a Marine Expeditionary Brigade (MEB), comprised of units one rung lower than those that make up the MEF. A Regiment fills the GCE of the MEB, an Aircraft Group makes up the ACE, and a Brigade Service Support Group (BSSG) provides combat service support.

#### **4. Marine Expeditionary Unit**

The smallest MAGTF is a Marine Expeditionary Unit (MEU) comprised of approximately 1,800 to 2,000 Sailors and Marines. Its warfighters are a Battalion of three rifle infantry companies, a headquarters company, a weapons company, a reconnaissance platoon and supporting artillery and armor units. The air combat element is a composite squadron of various aircraft, which in the future will include the CH-53E Sea Stallion heavy lift helicopter, the MV-22 tilt-rotor "Osprey", the AH-1 Cobra and the UH-1 Huey

helicopters, and a detachment of AV-8B harrier aircraft. The Combat Service Support Element of a MEU is a MEU Service Support Group (MSSG) organized around the traditional functional areas of combat service support to include engineers, supply, maintenance, landing support, motor transport, and medical. Refer to Figure 3.3 for the organizational design of the MAGTF.

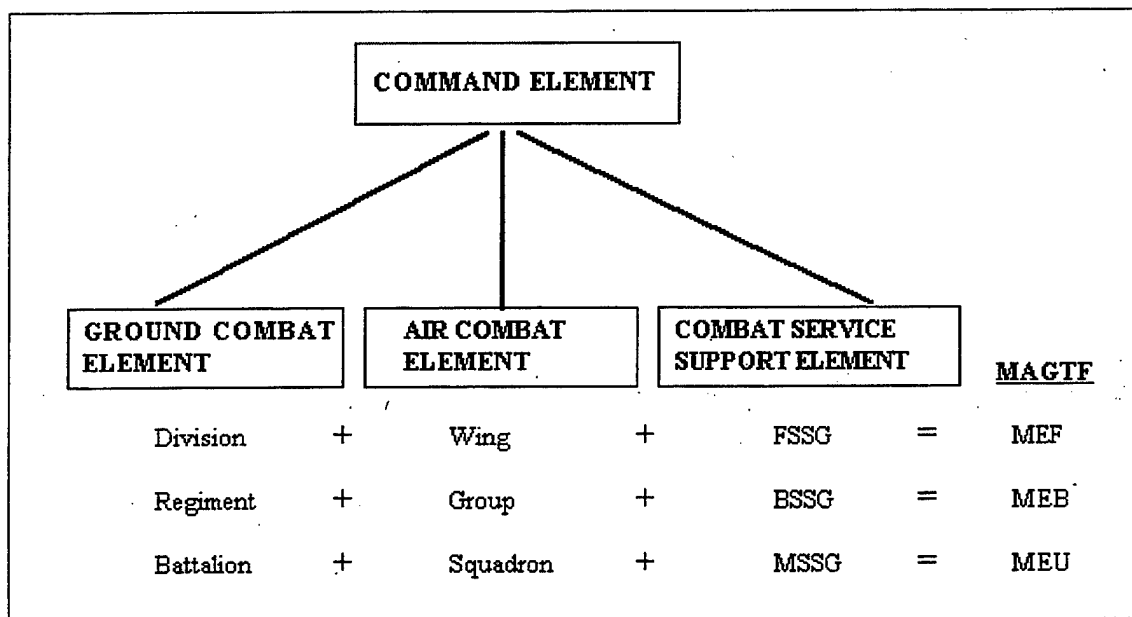

Figure 3.3. USMC MAGTF Structures.

#### 5. **MAGTF Over-The-Horizon Communications Capability**

The mission of a MAGTF as part of the NEF, or ARG, is to deploy throughout the world as a force in readiness prepared to support amphibious operations in support of US and allied interests. The MAGTF's command element must be capable of communicating with its higher headquarters and its subordinate command. This capability is extremely



important in the rapid assessment of intelligence and dissemination of critical information throughout the battlefield to subordinate commanders. OTH communications and the new concepts of OMFTS are challenging the MAGTF's ability to communicate. Presently, this is the subject of great debate and research by such organizations as the U.S. Navy Office of Naval Research (ONR), N85, Expeditionary Warfare branch, and the U.S. Marine Corps Warfighting Lab in Quantico, Virginia.

The next two following chapters contain the applied open standards and technical descriptions in terms of layer one and two of the ISO model for the primary systems that support the LRAM concept. This will allow the reader to understand the components of a proposed architecture to support OTH communications. The next chapter discusses existing systems such as satellite communications, and the Marine Corps Tactical Data Network (TDN). There is also a parallel discussion regarding future bandwidth requirements for execution of OMFTS operations. The chapter thereafter will introduce and discuss developmental systems that support littoral OTH requirements.



#### IV. EXISTING TECHNOLOGY

##### A. TRENDS AND REQUIREMENTS

The present trend in DOD is to take advantage of satellite communication systems that would form the principal or primary backbone of OTH communication in support of NEF operations. However, in the event of system failure, there are no current alternatives, or alternate communication paths for ship-to-shore communication, except line-of-sight (LOS) radio, which is severely hampered by distance limitations and size.

For example, DOD UHF satellites serve the primary means to satisfy OTH command and control requirements for stationary and mobile units. However, there are numerous limitations that restrict the use of UHF satellites to include: accessibility to the limited number of available channels; susceptibility to jamming; and limitations with frequency use based on characteristics of satellite transponders.

HF is a viable alternative; however, the use of HF is limited by the following: susceptibility to direction finding; propagation limitations; HF antenna deficiencies aboard amphibious ships, and lower quality voice and data communications.

Furthermore, there is a great lack of research and investigation in the area of emergent technology that addresses tactical level requirements for forces operating ashore in the littoral environment.

**1. DOD SATCOM Functional Requirements Document (DSFRD)**

The Defense Information Systems Agency (DISA) developed the DOD's SATCOM Functional Requirements Document (DSFRD) to describe service requirements for tactical satellite communications service in the post 2005 time frame. The contents of this document are updated annually based on CINC/Agency input and then validated by the Joint Staff. The document defines narrowband services associated with point-to-point communications between two users consisting typically of less than 64 KBPS full duplex circuit linking two user terminals, typically operating at the CINC operational level of execution. The flaw in this document is that it doesn't adequately address tactical users level or periods of services are met within the framework of current and emergent communication technology down to the tactical level. Nevertheless, it does provide a start point in attempting to quantify tactical user throughput requirements. [Ref. 18]

**2. SATCOM Shortfalls**

The document also presents national level scenarios in terms of Peacetime, combined major regional conflicts

(CMRC), and multiple lesser regional conflicts (MLRC). The peacetime scenario falls into the normal day-to-day operations category. The CMRC scenario represents the use of a large force in two geographically separate regions. However, this problem is exacerbated if forces are competing for satellite resources within the same satellite region. The MLRC commits use of force into localized areas in support of U.S. interests. The DSFRD document assumes forces were dispersed to four regions to support operations such as peacekeeping, humanitarian and conflict missions. The overall total bandwidth and circuit requirements for the 2005-2010 time frame are portrayed in Table 4.1 below. However, it does not provide the tactical environment imposed on the user.

The current DOD SATCOM systems even with planned upgrades are unable to support CMRC scenario in the 2003-2008 timeframe, when they are finally scheduled for replacement. The legacy systems of that time are expected to meet less than 25 percent of DOD's forecasted need. Furthermore, virtually all of the DOD-owned systems are geosynchronous satellites (GEO's) which limits their coverage to latitude 65 degrees North and South.

These systems cannot and will not in the near future be able to provide the required information throughput to small SATCOM terminals/antennas required for mobile users. Current studies show that DOD SATCOM UHF requirements, at most, can

meet half of the 2005-2010 time period requirements. In addition, they are not adequately protected, built to satisfy specific user needs (i.e., they're not interoperable with other systems), and lack flexibility down to supporting the tactical user requirements.

### **3. Future SATCOM Systems**

To fulfill these shortcomings, DOD has begun research in MSS systems such as International Maritime Satellite (INMARSAT) --already exists, and is being upgraded, Iridium, Teledesic, and Globalstar. INMARSAT is a geosynchronous (GEO) satellite; while Iridium, Teledesic, and Globalstar are each low earth orbit (LEO) satellites. Trunked services provide mobile users with 64 KBPS for ships at sea using Inmarsat, and 2.4 to 4.8 KBPS to a mobile user using Iridium, Teledesic or Globalstar. All of the three systems, except for Teledescic is partially functioning or will be fully operational by 2002. There are a number of bandwidth requests from commercial developers submitted through the Federal Communications Commission (FCC), but are only in the concept and design phase to consider as likely candidates to reliably satisfy DOD needs for the years 2005-2010.

<b>Scenario</b>	Peacetime	CMRC	MLRC
<b>Circuit Type</b>	MBPS/Circuits	MBPS/Circuits	MBPS/Circuits
Narrowband (Netted)	2.5/900	6.5/1500	7.0/1500
Narrowband (Point-to-Point)	115/2550	125/3200	135/3600
Total Narrowband	117.5/3450	131.5/4700	142/5100

Table 4.1. DOD 2005-2010 SATCOM Bandwidth Requirements.  
[Ref.23]

There are significant drawbacks in using solely commercial services. They include cost of subscriber service; on demand, assured access; and physical and traffic security and vulnerability issues.

For example, 30-day use of 100 trunks, with 10 users per trunk, and 24 hours availability using Iridium would cost close a Billion Dollars! In a theatre of operations you would have hundreds of users requiring access-on-demand, and guaranteed service. Thus, the cost of netted communications would be prohibitive alone. Aside from pure bandwidth, this is a compelling reason to develop tactical networks vice point-to-point systems, and continue to dedicate resources toward reliable network multicast schemes.

Furthermore, there are no assured access guarantees with Iridium. For one "cell" covering the size of Bosnia, Iridium would provide 80 circuits which any subscriber could use that has a mobile handheld subscriber unit (SU). There are also international global consortiums that have provided a substantial investment in each of the previous mentioned LEO systems. In return, it is only prudent the investors in those ventures should expect their fair share of investment return in a way that makes them favorable and popular among their customers. Similar problems exist for the other proposed LEO systems. Subsequently, it is necessary to look at other potential available alternatives.

One such example is the continued use of GEO, INMARSAT systems. However, in 1995 the 125 U.S. Navy ships with INMARSAT capability spent three million dollars in usage fees. Another alternative is to purchase government owned gateways, and install them throughout DOD to include onboard U.S. Navy ships. However, at this time, there isn't any conclusive data to support this venture. Globalstar, Iridium, Teledesic are other choices, but they are plagued with the same drawbacks discussed early in this section. However, Globalstar is presently developing a deployed containerized gateway concept that offers promising support for this mission.



#### **4. Initial Bandwidth requirements for LTRAN**

At best, Table 4.2 provides a breakout of minimum theatre tactical communications services to pass voice, data, and FAX requirements for initial introductions of forces into CMRC, and MLRC scenarios. It is completely unclear if this data is representative of all Commander-in-Chief's (CINCPAC) requirements throughout their area of responsibility. A given CINCPAC's operational environment, as well as the specific operational plans they support would should reflect, or dictate a precise need. As a result, it appears in theater bandwidth or channel allocations are entirely situational dependent, and at the discretion of the tactical commander. Unfortunately, if the commander requires additional access, it is inevitable that he will reach a limiting number of point-to-point determined connections. [Ref. 18] Once again, this is another reason to emphasize a network approach to littoral communications.

Mission Requirement	Minimum (voice/data/fax) in KBPS	Optimum (voice/data/fax) in KBPS
VIP/Flag Communications	2.4/4.8/4.8	4.8/9.6/9.6
Global Broadcast Service (GBS)	2.4/4.8/no	2.4/4.8/no
Combat Search and Rescue (CSAR)	2.4/2.4/no	2.4/2.4/no
Command and Control (C2) of Tactical Forces	2.4/2.4/2.4	2.4/56*/9.6
Maritime Operations Command Comm	2.4/2.4/2.4	4.8/56/4.8
Special Operations Comm	2.4/2.4/2.4	4.8/9.6/9.6
Naval Surface Fire Support (NSFS) Ship-to-Shore	2.4/4.8/no	2.4/9.6/no
Logistics Support Comm	2.4/2.4/4.8	2.4/9.6/9.6

Table 4.2. MSS SATCOM Requirements. [Ref. 23]

**B. MAGTF BANDWIDTH REQUIREMENTS**

**1. Initial Mission Support**

If the DISA data is considered a starting point, then Initial support estimates can be made based on the preceding discussion on DOD bandwidth data provided in Table 4.2. For example a Marine Expeditionary Unit of 1800 Sailors and Marines would require the following immediate bandwidth allocation contained in Table 4.3 during the initial stages of ship-to-objective maneuver:

<u>Type Service</u>	<u>Rate (KBPS)</u>
VIP/Flag Comm	24
Global Broadcast	7.2
CS	4.8
Command & Control	68
Special Ops	24
NSFS	12
Logistics	21.6
Peacekeeping and Humanitarian Operations	14.4
Military Support of Civilian Authorities	24
<u>Total</u>	<u>200KBPS</u>

Table 4.3. Initial Bandwidth Requirements for Littoral Operations. After [Ref. 18]

The estimate is focused on selection of mission areas to support the initial introduction of forces to a littoral region area. This may vary based on the mission, enemy

situation, terrain, and how widely troops are dispersed throughout the operational area. Based on this information, Command and control consumes 34% of the requirement. Second is special operations consuming 12%; followed by logistics at 10%. Naval Surface Fire support (NSFS) consumes 6%. However, none of the preceding three is executable without sea base fire support.

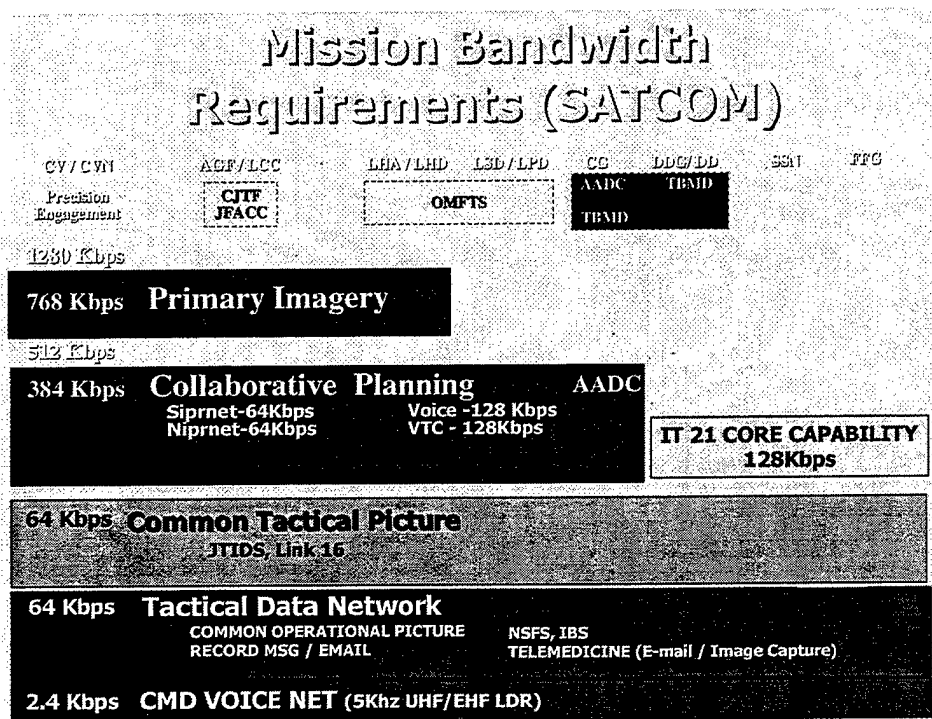

Figure 4.1. MEU Bandwidth Requirements for OMFTS.

After [Ref. 21]

## 2. MEU Requirement

Although the preceding discussion addresses immediate needs, the current MEU command element throughput capacity is designed to support up to at least 1.54 MBPS for voice

and data services for primary command and control of the build-up of forces ashore. Anything less than this rate and the MEU is thus limited to 64 KBPS for the entire force. Therefore it is necessary to substantiate future requirements based on OMFTS scenarios.

The Department of the Navy, Chief Information Officer (DON CIO) Information Technology Standards Guidance (ITSG) states that a MEU must deploy with at least a T-1 capability. [Ref. 19] However, it doesn't take any steps to describe the origins of this requirement. Further discussion conducted with representatives of the Operations Naval research, C4I Expeditionary Warfare Branch (N85) and the MARCORSSYSCOM Satellite Requirements Division substantiate this current requirement. However, specific needs for OMFTS are still undetermined. [Ref. 20] Although IT-21 is not a program of record, the Commander, U.S. Naval Forces Pacific Fleet also confirms this (see Figure 4.1) based on their exercise data and research thus far in support of littoral doctrine. [Ref. 21] Their total data rate to support a MEU and Amphibious Ready Group (ARG) executing OMFTS equals 1.280 MBPS. Allowing twenty percent for overhead and future system expansion equals 1.536 MBPS. An aggregate of 130.4 KBPS is required for common tactical picture, voice, email, fire support, image capture. 384 KBPS are reserved for collaborative planning on secure and unsecured connections, VTC and voice. However, current information doesn't

substantiate future critical baseline requirements for tactical systems supporting the immediate introduction of forces into the littoral environment. This includes not only tactical forces ashore, but equally important are the undersea warfare requirements to combat shallow water mines, small craft threat, and defense against shore based missile threats. Unfortunately, what information that is available regarding undersea requirements is classified, and should be addressed via separate research and investigation from this venue forward.

In summary, for the initial phase of a littoral operation DISA reports at least 200 KBPS is adequate to support the initial assault. This requirement is perceived to quickly increase proportionally with the increase of forces and activity ashore to at least 1.54 MBPS for a MEU command element that has established itself ashore. However, this information requires additional research analysis as it pertains to supporting NEF operations in the littoral operating environment.

### **3. MEF Requirement**

The deployed MAGTF will normally connect out of theater to the Defense Information Systems Network (DISN) by satellite. Links between the MEF command element and its MSC's, the Joint Task Force (JTF) headquarters, and other Service Component headquarters are provisioned primarily by satellite, although multi-channel radio may be used. The

Division, Wing, and FSSG will communicate laterally with each other and with their immediately subordinate units via multi-channel radio. The total current requirement based on information provided by the U.S. Naval Space Command in the Naval SATCOM Emerging Requirements Data base (ERDM) for the deployed MEF command element ashore in support of approximately 18,000 Marines and Sailors ashore is approximately 92.3 MBPS or 28 circuits (refer to Table 4.3). [Ref. 22] However, if logistics and air support remains sea based as in an OMFTS environment this value will decrease to 70.8 MBPS, or 24 circuits. Finally, if the entire MEF Command Element remains sea based, this value will further decrease to 16.6 MBPS or 14 circuits. This value is just above the line speed designation for Ethernet or equivalent at 10.0 MBPS, but less than T-3 at 44.7 MBPS (refer to Table 4.4). In summary, this would be the requirement to the sea base with the MEF onboard. This scales considerably to at least Fast Ethernet or equivalent at 100.0 MBPS for a MEF ashore executing a Maritime Preposition Force (MPF) offload as well as supporting assault forces executing OMFTS. If there are achievable tradeoffs, this can conceivably drop down to OC-1 at 51.8 MBPS provided some of the SATCOM requirements are received only at one location for further distribution via alternate paths.

Informal comments made to the author from throughout the communications community indicated the fault of this

discussion. First of all, it is hard to anticipate the MEF network configuration for any one set scenario. What is important to realize is the MEF command and control structure design should be flexible enough to operate both at sea and ashore. This requires the sea base platforms support this requirement --which is a present deficiency. However, it is unclear in the ERDB how units like the MEF will compete against units within the carrier battle groups or the amphibious ready squadron for available bandwidth. What typically occurs is many users are expected to operate at severely degraded levels of service. This provides a compelling reason to network systems.



Unit	Circuit Nomenclature	Data Rate (KBPS)	Voice	Data	Video	>1 type
MEF	MEF Command 2	2.4	X			
MEF	MEF Command	10,240		X		
MAGTF	MAGTF Command Network	2.4	X			
MEF	MEF Command 1	2.4	X			
MEF	MEF TAC 1	2.4	X			
MEF	MEF TAC 2	2.4	X			
MEF	MEF Intel	2.4	X			
MEF	MEF Recon	2.4	X			
MEF	MEF GCE Command	2.4	X			
MEF	MEF TACAIR Command	2.4	X			
MEF	MEF Radio Bn	2.4	X			
MEF	SABER	4.8		X		
MEF	MEF DSN Entry	1,544	X			
MEF	MEF Command	10,240		X		
SJTF	SJTF HQ DSN Entry	1,544	X			
SJTF	SJTF HQ DISN Access	10,240				X
MEF	MEF DISN Access	24,128				X
MARDI V	MARDIV DISN Access	10,240				X
MAW	MAW DISN Access	10,240				X
FSSG	FSSG DISN Access	10,240				X
CMEF	CMEF Command 1	2.4	X			
CMEF	CMEF Command 2	2.4	X			
CMEF	CMEF Intel	2.4	X			
CMEF	CMEF TACAIR Command	2.4	X			
MEU	MEU DSN Entry	1,544	X			
MSS	Mobile Satellite Services	2.4	X	X		
MEF	MEF Broadcast	24,000		X		
SJTF	SJTF Command	1,544		X		

Total Circuits: 28 Circuits

Total KBPS: 92,312.8 KBPS

Table 4.4. Total MEF bandwidth Requirements. After [Ref. 22]

<b>Unit</b>	<b>Circuit Nomenclature</b>	<b>Data Rate (KBPS)</b>	<b>Voice</b>	<b>Data</b>	<b>Video</b>	<b>&gt;1 Type</b>
MAGTF	MAGTF Command Network	2.4	X			
MEF	MEF Command 1	2.4	X			
MEF	MEF TAC 1	2.4	X			
MEF	MEF TAC 2	2.4	X			
MEF	MEF Intel	2.4	X			
MEF	MEF Recon	2.4	X			
MEF	MEF GCE Command	2.4	X			
MEF	MEF TACAIR Command	2.4	X			
MARDIV	MARDIV DISN Access	10,240				X
MEF	SABER	4.8		X		
MEU	MEU DSN Entry	1,544				
CMEF	CMEF Intel	2.4	X			
MEF	SABER	4.8		X		
CMEF	CMEF TACAIR Command	2.4	X			

Total Circuits: 14 Circuits  
Total KBPS: 16,608 KBPS

Table 4.5. MEF Bandwidth Requirements with seabased command and control. After [Ref. 22]

#### 4. MAGTF Shortfalls

In summary, the previous documents do not differentiate or provide a clear division between strategic, regional, and tactical requirements, especially with respect to crucial OTH communications in the LRAN environment. In addition, they do not address issues such as frequency of service, or specific user requirements, or the number and type of user, which are essentially different for the strategic to the tactical level. Fortunately, there are existing reliable and scalable well thought solutions both in the Navy and Marine Corps that can form the basis of a network centric approach

to the LRAN system. The subsequent discussion in the next section and following chapters introduce technologies that exhibit these precepts.

#### **5. Marine Corps Tactical Data Network**

Thus far it should be apparent that as the area of responsibility for attacking units matures and the environment appears relatively secure, during future phases of operations ashore, the MAGTF commander has the option to move elements or the entire command and control structure from the sea base to shore. In which case the Tactical Data Network would be established as the primary means of communications for forces ashore as well as back to the sea base. [Ref. 23]

#### **6. Fiber Distributed Data Interface (FDDI)**

TDN employs the FDDI standard, which supports data rates over a high-speed backbone of 100 MBPS throughout the MAGTF. It is based on the ANSI X3T9.5 Standard for a network architecture that is designed to use fiber optic lines at very high speeds. The FDDI architecture can be used for two types of tactical networks. In a backbone network where the FDDI architecture connects multiple networks, or as a backend network to connect mainframes, minicomputers, and peripherals. It can connect up to 500 nodes employing a dual ring topology with approximately 2 km between nodes. By substituting single mode fiber and laser transmitters,

distances between nodes increases up to 20 KM. Such a solution is commercially available.

A FDDI network contains the following hardware elements: stations, network interface cards (NIC), fiber optic cable, connectors, concentrators, bypass switches, and couplers. The Marine Corps TDN employs all these elements plus dual attachment stations (DAS) to take advantage of the dual ring topology of FDDI. The bypass switches are used in the event one of the nodes is down, and is bypassed. Couplers serve to split light signals into two or more signals. For example, a coupler may be used to transmit a signal to multiple nodes. Concentrators serve as a wiring center for FDDI nodes, and provide connections between the dual rings at the subnets. [Ref. 7] The standard FDDI frame consists of up to 4500 bytes of data information, plus up to a 28-byte header frame. [Ref. 24]

The TDN is deployed at the MEU up to the MEF level, including the major subordinate commands (MSC). It is housed in the High Mobility; Multi-Wheeled Vehicle (HMMWV) mounted shelter. It consists of servers interconnected by point-to-point multimode fiber optic cable linked to commercial routers. Most importantly, it supports hybrid networks, or subnets, by attaching to the ring through a concentrator. It uses a light emitting diode (LED) for packet transmission. One ring transmits clockwise, while the other transmits counterclockwise. If either one breaks, the other can be

used as a backup. If both break at the same point as a result of hostile action, the two rings can be joined into a single ring approximately twice as long. Although this feature isn't necessary in a number of commercial applications, and isn't recommended by the ITSG for shore or base installations. However, its survivability is ideal for the tactical environment.

The basic FDDI protocols are closely modeled after the commercially accepted IEEE Token Ring Standard 802.5. In a token ring a special bit pattern, called the token circulates around the ring whenever all stations are idle. When a station desires to transmit a frame, it is required to seize the token and remove it from the ring prior to transmit. A station holds the token for a designated token-holding time. [Ref. 7] Thus, token rings can be configured to provide a guaranteed fraction of the bandwidth to high-priority traffic, such as digitized map imagery data, voice traffic, or mission critical intelligence data. The TDN Server is deployed from the MEF to the battalion level, and packaged in hardened, transit cases, and Marine portable. Besides supporting network traffic for the MSCs, the technology is commercially available, but with improved packaging for survivability in a combat environment. It also hosts to the following primary applications. [Ref. 23]

**a. Tactical Combat Operations (TCO)**

TCO is the primary tactical data system used by commanders and operations officers. TCO provides commanders with a comprehensive, near real-time view of the battlespace. TCO generates the majority of traffic of the systems hosted on the tactical Internet.

**b. Intelligence Analysis System (IAS)**

IAS provides automated support for the direction, collection, processing, production, and dissemination of intelligence within the MAGTF. Intelligence data may either be distributed to multiple recipients without their explicit request ("push"), or users may download required information after browsing through a central repository ("pull").

**c. Advanced Field Artillery Tactical Data System (AFATDS)**

AFATDS is an automated command and control system for artillery units and units that coordinate artillery fires.

**d. Marine Combat Service Support Command and Control System (MCSSC2)**

MCSSC2 aggregates logistics requests and data from requesting units of the MAGTF, and processes this into a coherent representation of the logistics support infrastructure.

TDN differs from commercial systems in several respects. Radio links, satellite links, and even some terrestrial wired links will not support the high data rates common in a commercial environment. Because some links will support higher capacities, the tactical Internet will have to contend with both the presence of high and low bandwidth segments, and with the dynamic, turbulent tactical environment. It will be subject to intentional disruption or destruction in forward areas. The network topology can also change frequently since unit subnets relocate often, or some users may constantly be on the move. Most importantly, the TDN exhibits considerable scalability based on the characteristics of the previous described token ring standard and supporting hardware. As a result, the TDN forms the ideal backbone to the shore based tactical systems. Unfortunately, it does not optimize available bandwidth from the various user subnets, such as SATCOM or HF systems.

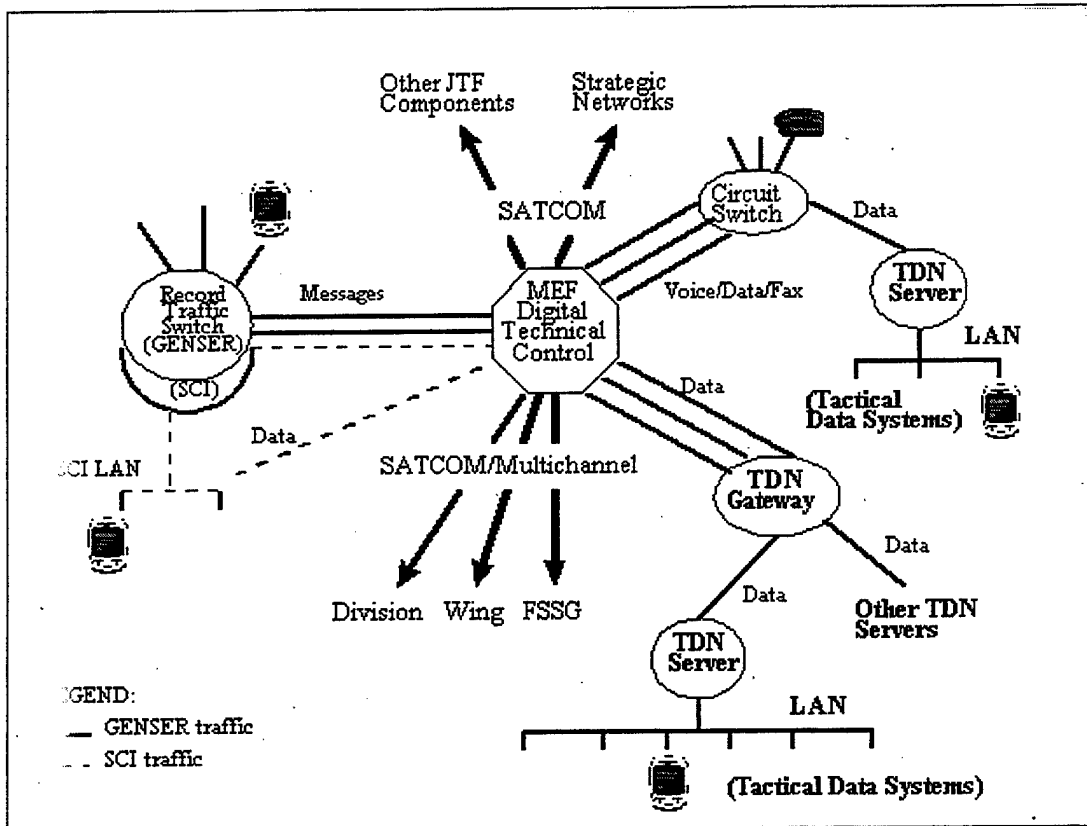

Figure 4.2. Marine Corps Tactical Data Network System. [Ref.



## 7. Range of TDN Services

In the past, the MEF communications architecture did not provide data service below the battalion level. System upgrades now only provide 1.6 KBPS to the tactical user in the case of the SINGARS, frequency-hopping radio. However, there is considerable evidence now that a change in littoral doctrine characterize by OMFTS requires accompanying data services to the lowest tactical levels possible, and is crucial to the LRAM concept. In this case, future digital systems deployed below the Battalion level are essentially a node into the TDN. Furthermore, these systems could adequately address the bandwidth loading shortfalls characterized in the previous document reviews for digital systems supporting these units in the initial phases of an OMFTS operation.

In principle, the intended primary characteristic of LRAM technology is that it would form a robust dedicated communications backbone that would complement, or parallel radio and satellite communication technologies originating from tactical users ashore to the sea base. It would interconnect with existing and developing network based infrastructure such as the Navy's Automated Digital Network System (ADNS) discussed later in the next chapter, and the Marine Corps TDN.

There are two options that are receiving considerable attention. One option is to develop shore located hetero-

geneous, terrestrial and wireless LAN networks with access to small-diameter fiber optic cables (SDFO) connected to a system of moored relay stations with aerostats. Another option is to establish the same combination of terrestrial, wireless networks, but employ buoyed wireless LAN radio relay stations that would serve as one path to ships at sea. [Ref. 25 and 26] In both cases, research by the U.S. Naval Facility Engineering Service Center (NFESC) has resulted in the Sea Based Aerostat Information Link (SAIL) program. These concepts are discussed in the following chapter.

## V. EMERGENT TECHNOLOGY

### A. WIRELESS NETWORK STANDARD

The communications infrastructure as it exists today in the Navy and Marine Corps consists of analog voice and low data rate (LDR) digital systems, and does not meet respective service tactical requirements. Presently, SPAWAR is responsible to the Marine Corps and the Navy for investigating future High Data Rate (HDR) line of sight (LOS) and beyond line of sight (BLOS) voice, data, and video mobile wireless networking technologies. HDR systems operate at a throughput rate of between 64 KBPS to 2.0 MBPS.

The goal for SPAWAR is to develop wireless platforms that automatically configure networks based on the topology of a mobile platform, such as reconnaissance team, tank, HMMWV, or an infantry unit. [Ref. 27 and 28] A Mobile Wireless Network is an autonomous system of routers connected by wireless links. Each network node (router and its interfaces) may support multiple wired or wireless hosts. The routers and hosts are free to move in an unconstrained manner. Some nodes may have connectivity back to fixed infrastructure networks.

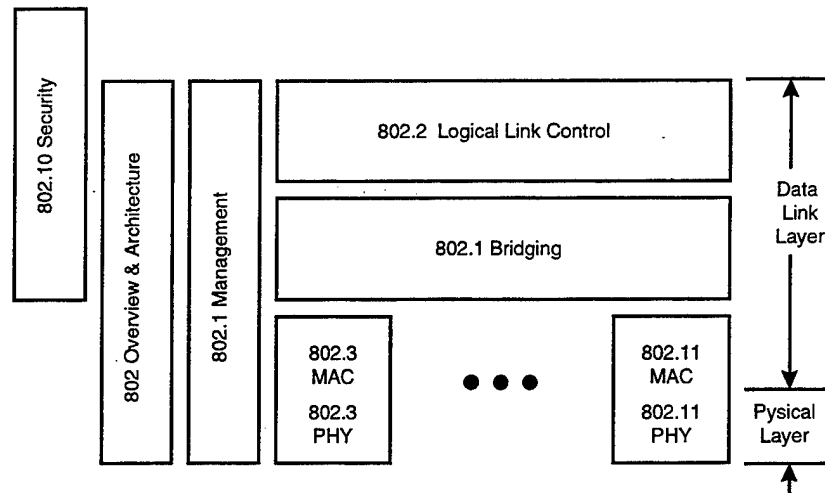

Figure 5.1. Interaction of the IEEE 802.11 Standards.

[Ref. 27 ]

As portrayed in Figure 5.1, The IEEE 802.11 wireless standard defines the protocol and waveform standards of data communication equipment at the physical and data layer of the OSI model for wireless connectivity for fixed, portable, and mobile wireless nodes within a local, or in this case a tactical area of responsibility. In addition, the wireless network system must provide for automatic relaying to extend the line of sight (LOS) range via multi-hop relaying between mobile platforms, or nodes. The definition of various relaying services such as a repeater, bridge and router are important in the discussion of wireless networked radios. For example, a repeater blindly repeats data within a homogeneous network and involves strictly the physical layer. A bridge relays information between networks with different physical and data link layers but identical

network layers. An example would be a connection between an IEEE 802.3 Ethernet LAN and an IEEE 802.11 Wireless LAN. A router involves relaying information between two different heterogeneous networks and includes the physical, data link, and the network layer. For instance, a router could relay information between an IEEE 802.11 Ethernet LAN and an X.25 interface. For this reason, networked radios are often referred sometimes as "mobile wireless router." [Ref. 28]

### **1. Wireless Systems**

There are currently a number of systems under investigation by SPAWAR, and throughout the DOD. However, one of the leading candidates for the Army, Navy, and Marine Corps is the Near Term Digital Radio (NTDR) system. The specific goal of the NTDR program is employ COTS technology in development of a radio that costs less than \$10K per radio. NTDR is a digital radio that provides IP-based network communications while on the move. It uses two antennas, one for UHF communications and one for an embedded Global Positioning System (GPS) transmitter/receiver. Its intended design goal is to provide LOS communications up to 20 km unobstructed. To achieve this, the 802.11 standard is slightly modified to support extended range communication thus allowing for forward error correction or interleaving required for communications over long distance. On the average, NTDR is reliable at 15 km unobstructed, but experiences "time outs" or lost packets at 20 km. NTDR

doesn't employ the formal aspects of quality of service (QOS). This particular area is presently the subject of ongoing research at SPAWAR System Command. [Ref. 27]

## **2. Wireless Network Architecture**

Addition of data service to the battalion and units below this level, coupled with the concept self-configuring, mobile wireless networked radios represents a revolutionary change to the MAGTF communications architecture. It will essentially foster implementation of end-user terminal applications and devices necessary to support maneuver units executing OMFTS type missions.

Wireless networks, like NTDR are designed to self-organize into a dynamic two-tiered network scheme of backbone cluster heads and affiliated cluster members. Data is routed automatically between users employing Radio Open Shortest Path First (ROSPF). Data can hop across up to seven nodes with clusters of up to five radios at each node. Figure 5.2 is example of the NTDR architecture. It is self-healing in the event of cluster head failure. Topology data is determined from radio node data tables stored in each NTDR. Consequently, if one of the radios in the cluster fails, another will takeover network management. NTDR transmits at a rate of 500 KBPS, and handles message data packet sizes ranging from 52 to 2048 bytes, and operates on a wireless Ethernet standard (the 802.11 standard data packet size is 2346 bytes). [Ref. 28]

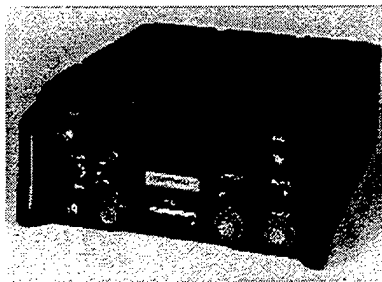
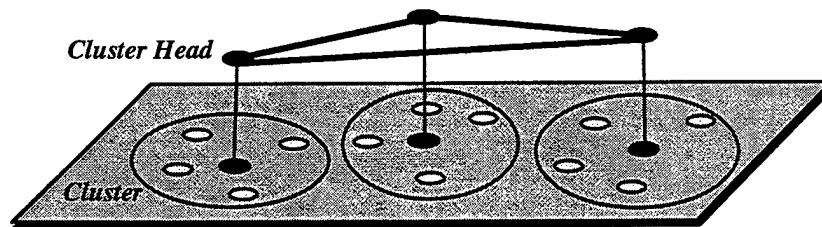

Figure 5.2. NTDR Network Architecture and Radio.

[Ref. 28]

### 3. NTDR Tests

The NTDR system has been subject to several preliminary field tests. In one test 12 NTDRs were networked together at fixed sites and achieved 64 KBPS data rates. In another test 49 NTDRs were networked with mobile nodes. Message completion was just over 97% completion rate. Average data rates were achieved at 200 KBPS. In some cases the mobile nodes were traveling at speed up to 55 mph. The U.S. Army has tested the NTDR system in several field exercises. For example in their Force XXI exercise, 70 NTDR nodes were able to communicate within a 20 km by 30 km box unobstructed.

[Ref. 28]

#### 4. Employment Options

SPAWAR and NFESC are presently investigating options to support the U.S. Marine Corps War Fighting Lab Urban Warrior experiments, particularly the "Internet-node-in the sky" (INITS) concept. One test candidate is for maneuver forces to deploy ashore with the system, and use land based and buoyed wireless antenna relay sites out for OTH communications out to the sea echelon area. Another option is to integrate the NTDR with a buoyed aerostat to increase LOS range of the relay communication system during the initial STOM phase of OMFTS. Relay distance is a critical factor in STOM, because units are expected to maneuver ashore from the launch and recovery distances depicted in Figure 5.3. NTDR is intended to go ashore with these troops as their primary means of communication. [Réf. 27]



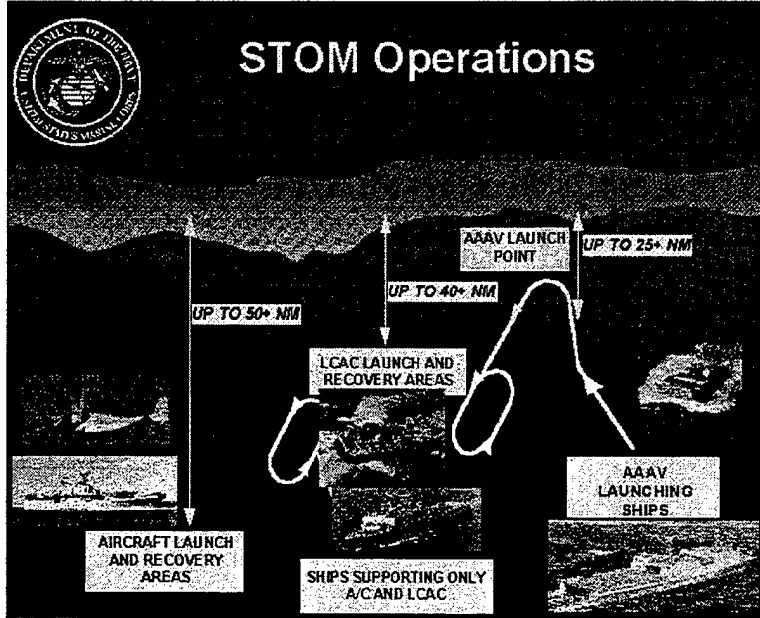

Figure 5.3. STOM Launch and Recovery Distances. [Ref. 5]

**B. AUTOMATED DIGITAL NETWORK SYSTEM (ADNS)**

In an effort to create a more efficient, interoperable communications environment for its ships at sea the navy has developed ADNS. Because of its recent introduction into the fleet and the evolving nature of the program it is not fully implemented throughout the Navy. Therefore, for the purposes of this study, it has been included under this section. However, because of the technology, it offers a network solution for connecting and merging heterogeneous communication systems into one digital transmission system that is ideal for OTH communications and the Marine Corps TDN.

## **1. Characteristics**

ADNS provides a means for organizations to centralize and automate the operation of multiple independent radio communication systems into an efficient communication network. It primarily provides connectivity for transmitting bits (in network terminology: IP datagrams) which may represent voice, video, or data by creating a seamless unit to unit, unit to ship, or ship to unit network. The standard ADNS datagram carries 64 bytes of header information wrapped around varying size datagrams based on the minimum transmission unit of the input system. ADNS manages all of the radio assets within one system and creates a reliable multiple path communications network. This network is essentially a radio-based Wide Area Network (Radio-WAN). [Ref. 29]

## **2. ADNS Architecture**

The internals of the Radio-WAN are the radio systems configured to support ADNS. The hardware used in ADNS is COTS equipment but it is very implementation specific. Using load-balancing concept ADNS spreads traffic equally across appropriate radio links such that the available capacity is the sum of all the links. ADNS does not provide additional bandwidth but instead multiplexes the bandwidth that is already available from legacy systems.

ADNS allows platforms with more than one transmission path to integrate these different systems via

one system, which then distributes data throughout the different paths in the most efficient manner. This is desirable for several reasons to include load sharing, cost effective management of bandwidth, leverage existing Internet technology, communication flexibility with efficient load sharing, and ease of upgrade with new systems. In general, ADNS has proven to provide a four-fold increase in communication utilization of legacy systems. [Ref. 29 and 30]

### **3. Component Mix**

Figure 5.4 displays relative positions of each component in the ADNS architecture. The minimum component mix needed for a complete ADNS installation to support a particular communications technology consists of: LAN-router-CRIU-CAP-cryptographic device-modem-RF system.. A description of each ADNS component is provided below. [Ref. 30]

#### **a. Router**

The router is the key component to the ADNS system. It accepts outbound IP packets from the TDN and selects the best path for reaching its intended destination. The best path is based on available bandwidth in each of the possible channels. In principle, if a high data rate channel is available its low cost (to send data) will provide the

best versus a low data rate system such as UHF. The router is COTS equipment.

**b. CAP to Router Interface Unit (CRIU)**

The CRUI assigns priorities to outbound IP datagrams. Priorities are based on two things: the host machine on the LAN sending the packet, and the host application. The IP source sending datagrams is recognized as the dominant factor, with the application second. The ascending order of priority is from 0 to 15, and is used to assign a datagram to a CAP when it leaves the CRUI. The priorities are placed in the packet header by the CRUI and passed to the CAP where priority queues are maintained. A net manager prepares the priority configurations and sends them to the CRUI for priority determination, or they can be assigned to the application within the host computer. The router outputs to the CRUI are Ethernet with one for each subnet. The CRUI makes the router think it is connected on Ethernet to all other routers attached to the subnet. [Réf. 32]

**c. Channel Access Protocols (CAPs)**

The CAPs contain the media access mechanisms, and are the queues for outgoing IP datagrams. They fit into the medium access control sub-layer of the ISO data link layer. Each channel has a CAP, with internal protocols to ensure the appropriate radio net receives the packet correctly. The

CAP accumulates datagrams until it reaches a transmission unit based on the channel capacity, or what is sometimes referred to as the maximum transmission unit (MTU). The CAP is also able to report to the CRUI when it is nearly at capacity. In which case, the CRUI then reallocates datagrams to another CAP, and issues a source quench for that system. Additional CAPs are created for each new radio net that is installed into ADNS.

**d. Security and Encryption**

Each channel has a cryptographic device. ADNS operates at a GENSER level, with encapsulated datagrams from the network encryption system. Links may be encrypted on a link by link basis. Network Encryption Service (NES) is employed to provide virtual private networks (VPN) service across an entire ADNS span.

**e. Modem**

Each CAP has a modem specifically built each of the transmission media. For example, there is one for Inmarsat B, UHF radio, and UHF SATCOM. As well, there would have to be a modem built specifically for NTDR, and other shored based radio systems.

In theory, the router accepts outbound datagrams from the LAN and selects the best path for reaching the destination, independent of the transmission means. From the Channel Access Protocol (CAP) to Router Interface Unit

(CRUI) back (to the left) there will be only one of each for a given installation. From the CAP forward (to the right) there will be one chain for each radio system that is part of the system (i.e. there may be UHF SATCOM chain, an RF LOS chain, an HF chain, etc.) In this particular configuration there are three RF paths connected to ADNS.

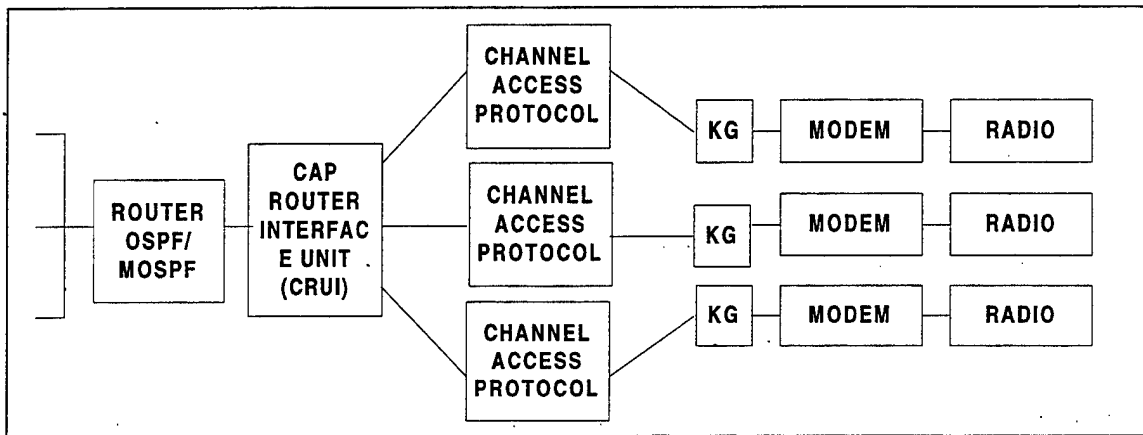

Figure 5.4. ADNS Components. After [Ref. 30]

The following sequence describes the events that occur when sending traffic:

1. The router accepts outbound datagrams from the LAN and selects the best path for reaching the destination.

2. The CRUI, which interfaces between the router and CAP, assigns a priority to outbound IP datagrams. Priority is inferred based on both the source application and the host from which the datagrams originated.

3. At the CAP the datagram is placed in a queue to

await transmission. Datagrams are stored in the CRUI in 16 buffers. Each buffer has an assigned priority. The buffers are drained by priority to the CAPs in order. Each CAP has only one buffer.

4. When the datagram leaves the CAP it passes through a cryptographic device and then passes through a modem specific to the transmission media and then enters the transmitter.

5. Upon arrival at its destination the datagram, traveling through a mirror image of the originating system terminates at the host specified in the IP header.

#### **4. TDN and ADNS**

Adoption of ADNS as the LRAN communications system hardware suite would make sense for the following reason: LRAN could accept and administer to any type traffic, convert it to digital or light signal if fiber optic cable is used as the transmission media, and pass it on into the Marine Corps TDN. Likewise, traffic originating from the TDN is sent to its intended recipient via the shortest route first. In this context ADNS is a subnet of the TDN, and is employed to route traffic through various existing tactical transmission systems such as SHF SATCOM, and troposcatter radar, and UHF LOS, and VHF radios. Another option is to fiber optic cable "run" from ADNS ashore, across the beach,

through the surf zone, out to sea as part of a seabased aerostat information link (SAIL) as portrayed in Figure 5.5. [Ref. 31] A system design of this concept is displayed in Figure 5.6 and discussed later in the following chapter. Network management and traffic priority assignment are operator controlled by the Network Managers co-located with the Command Operations Center (COC). The ADNS suite of equipment can be easily deployed in a tactical vehicle the size of a HMMWV.

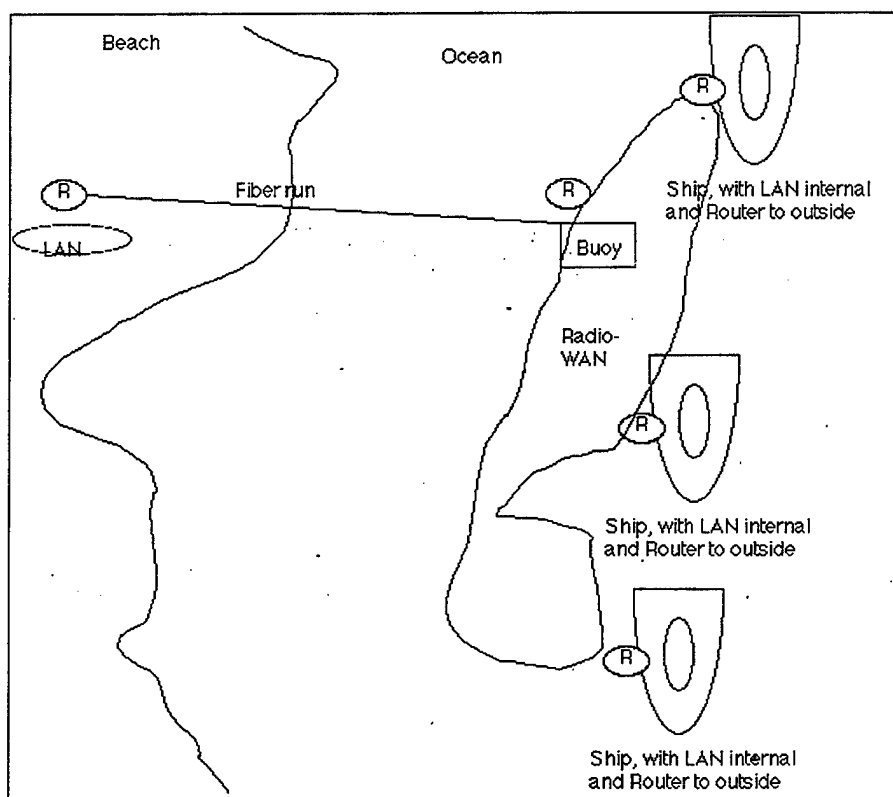

Figure 5.5. ADNS and SAIL. [Ref. 31]



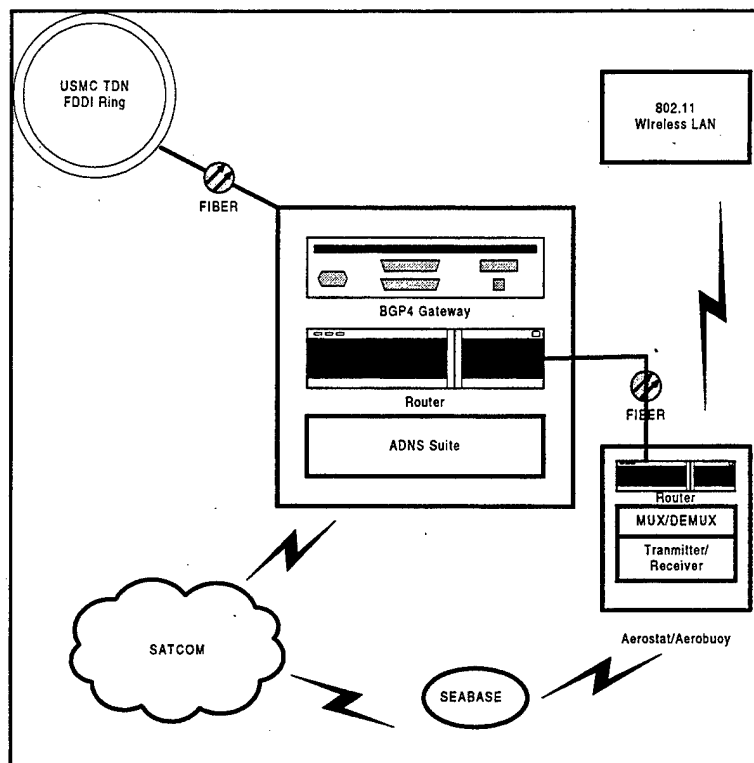

Figure 5.6. ADNS and the Marine Corps TDN.

In conclusion to this discussion, a general rule set best explains the system integration of TDN and ADNS with radio-WAN and terrestrial links:

1. Fiber, where available should connect router-to-router. The FDDI LAN is the exception. In the case presented here, the undersea fiber cable link is a subnet to the router prior to ADNS.

2. Radio, or SATCOM links should be snapped into the ADNS structure (CAP-to-CAP).

Because ADNS employs routers at the borders of the network--into and out of a ship, or tactical network--one and two

above exhibit desirable qualities of compatibility and scalability.

The U.S. Navy Space Systems Command in San Diego is responsible for ADNS program management and fleet integration onboard Navy ships. The Joint Maritime Communications Strategy (JMCOMS) is both a technical and program strategy, which implements the communications segment of the Navy's C4I architecture. The JMCOMS program goal is to incorporate the latest advances in commercial and military communications technology.

### **C. SEABASED AEROSTAT INFORMATION LINK**

#### **1. Technology Background**

The Naval Facilities Engineering Service Center (NFESC) has already initiated an Advanced Concept Technology Demonstration Study (ACTD) to investigate the feasibility of a employing Seabased Aerostat Information Link (SAIL) as a means of satisfying the growing military littoral OTH communication requirement. [Ref. 26] The information contained in this section is based on the author's participation in SAIL Concept and Development Phase of the program.

#### **2. Principle SAIL Technologies**

The SAIL system under development utilizes three key new technologies:

- High bandwidth networked radios.

- Aerostats, modified to operate from buoys at sea, termed aerobuoys.

- Rapidly deployable, expendable undersea fiber optic cables installed from shore to aerobuoys or shore-to-shore.

[Ref. 31]

The SAIL concept will enable U.S. Navy ships supporting shore forces to quickly and safely communicate with those shore forces for operational and logistical support via high volume, secure, reliable communication links (see Figure 5.7). The communications links can utilize either just the aerobuoys (relays), the aerobuoys with undersea fiber optic cable links, the fiber optic cable as a shore-to-shore festoon link, or many possible combinations of these elements.

The radios and supporting communications electronics are being developed under other or existing programs, such as the NTDR system, as are rapidly-deployable small diameter fiber optic (SDFO) seafloor cable systems and aerostats. The design goal of the SAIL program is develop technology to operate the aerostats at sea as aerobuoys, plus develop architectures and network topologies to link all these technologies together into a viable, versatile set of communications links that can be configured to support LRAN requirements.

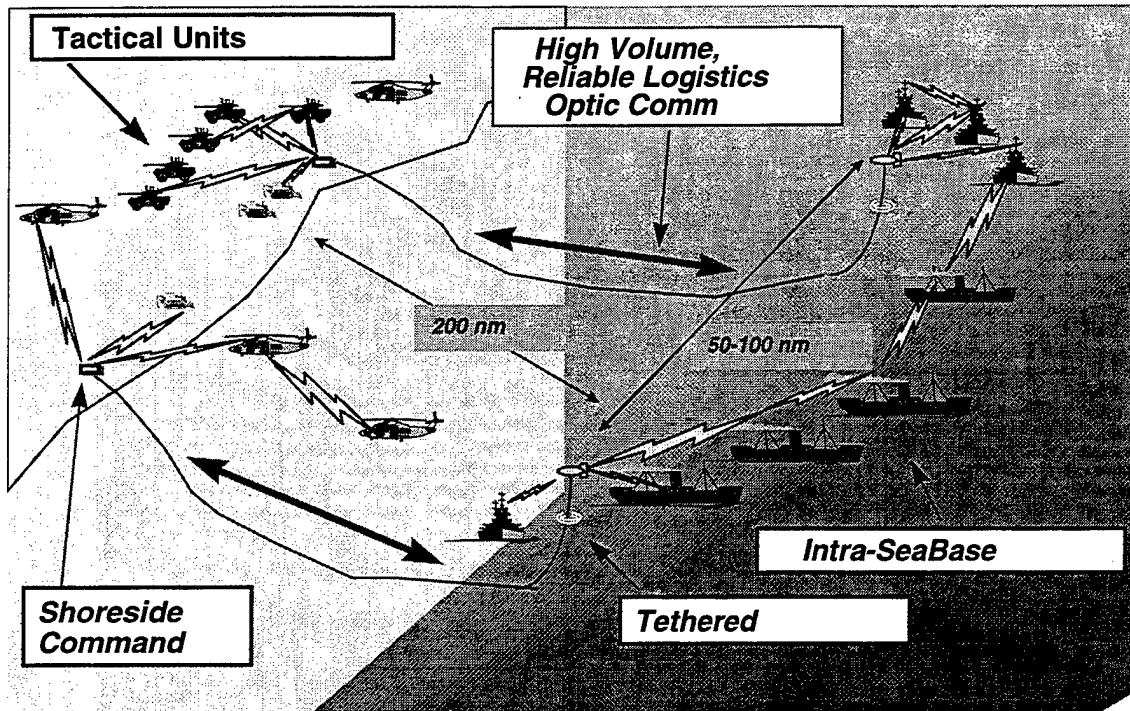

Figure 5.7. The SAIL Concept. [Ref. 26]

### 3. Technology Base

There is considerable interest in aerostat technology. For example, the U.S. Navy is considering the use of aerostats as Cooperative Engagement Communications (CEC) relays for ship defense, targeting, and ballistic missile defense operations over an entire theater of operations. After evaluating a number of airborne sensor concepts for detection of cruise missiles, the Pentagon told the Senate Armed Services Committee that "the most cost-effective solution would be a mix of fixed-wing aircraft and aerostats." [Ref.31] Advocates contend that a high altitude combination of radar and other sensors will "facilitate detection and track of low observables in high clutter environments."

**a. U.S. Army**

Industry is conducting an aerostat study on behalf of the U.S. Army to define concepts for the employment of aerostats in cruise missile defense. Long endurance and low, or no, fuel consumption are promising characteristics for missions ranging from border surveillance to test range monitoring.

**b. Desert Storm**

In 1985, the Government of Saudi Arabia conducted a full-scale demonstration of a Low Altitude Surveillance System (LASS). The purpose of the Royal Saudi Air Force LASS was to detect fighter sized intruder aircraft flying at low levels of ranges up to 160 nautical miles. Performance was verified during actual flight tests against target aircraft. The LASS was designed to relay information to a remote air defense terminal and to relay radio messages to interceptor aircraft.

Managed by the U.S. Marine Corps Systems Command under a foreign military sales program with the Kuwait Air Force, a LASS provides around-the-clock, 200 mile surveillance against surface vehicles, low flyers, and maritime threats. The Kuwait LASS is a 71 meter aerostat flying at 15,000 feet with a lookdown radar. The tethered aerostat system gave Kuwait the first warning of the Iraqi attack, detecting the mass movement of Iraqi armor across the Kuwait

border. Since 1981, the Israeli Defense Force has used aerostat-mounted radar to guard against surprise attack by low-flying aircraft.

**c. Drug Interdiction**

Another LASS is a network of aerostat systems stretching across the U.S. Border. These systems comprise an "electronic picket fence," reducing the chances that drug-smuggling aircraft will enter the U.S. undetected. Stationed at altitudes of up to 15,000 feet, the LASS systems are 71m aerostats that contain look-down radar that are especially valuable in locating and tracking aircraft that fly at low altitudes in an attempt to evade ground based electronic surveillance. Target information is continually relayed to a computerized command center operated by the U.S. Customs Service.

**d. Maritime Interdiction and Surveillance Team (MIST)**

The Maritime Interdiction and Surveillance Team (MIST) system is a 25 m aerostat that carries a lightweight sea surveillance radar for U.S. Coast Guard use in the interdiction of drug traffickers in the Caribbean Sea and the Gulf of Mexico. The MIST I system employed a 25 m aerostat and a Litton APS-504(V)-2 radar mounted on a 194 foot offshore re-supply vessel. The successful demonstration of this system was followed by MIST II, a 25m aerostat

and an APS-504-(V)-3 on the vessel Jan Tide. A third MIST system, employed a larger 31-m aerostat with an upgraded version of the APS-504(V)-3 radar and was deployed on the Carlson Tide. All of the MIST systems featured a Kevlar strength member power tether with optical fibers for the relay of radar and aerostat data to the shipboard operations center. The seabased aerostat program was terminated in the early nineties as a result of improperly budgeted, although not particularly high lifecycle costs.

**e. Undersea Fiber Optic Cable**

The U. S. Navy undersea surveillance community has been developing SDFO cables for rapid installation as part of seafloor sensor systems in support of undersea sensor detection systems. Under other programs, such as the Advanced Deployable System (ADS) program, the Navy has successfully fabricated, wound into cable packs, and installed from at-sea platforms hundreds of kilometers of SDFO seafloor cables. The ADS program also has developed battery-powered electro-optic repeater packages compatible with rapid installation systems. These provide a mission life compatible with regional conflict requirements.

Because of the established technology base, The SAIL system needs only to extend that capability to operations from the decks of platforms that will be readily available in littoral OMFTS operations, such as LCU's and

LCAC's. As stated in NFESC studies, "The technology challenge is primarily a packaging design and platform interface issue." The shore site(s) and Seabased vessels employ the communication link to form a wide area network between their local area networks. [Ref. 31]

The aerostat relay station will be the platform providing the communication link between the ships' RF UHF communications and other aerobuoy relays or the fiber optic cable trunk from the seabase to the shore. Aerostat communication payload is estimated to be relatively small, on the order of 100 to 200 lbs.

#### **4. LOS Over-The-Horizon Communications**

The line-of-sight requirement for the aerostat is 50 to 100 km. A 50-km line-of-sight equates to a 7,854 sq. km area coverage, and a 100 km line-of-sight equates to a 31,416 sq. km area coverage. The tether will connect the aerostat to a floating moored platform or buoy and will provide the junction between the aerostat and the seafloor trunk (when used).

Given the top-level communications bandwidth the major top-level trades being conducted in the SAIL program are:

- Aerostat altitude and spacing vs. area coverage and cost.
- Combinations of aerostats vs. SDFO cable OTH links.



The operating altitude of the aerostat is a driving parameter in the overall aerostat analysis and in the trades on aerostat design. The effective LOS goes up with increasing altitude (up to the point at which power limits the effective signal-to-noise ratio of the communications link or sensor payload). Therefore, the number of aerostats required providing a given length of relay link or total area of communications coverage goes down with the operating altitude of the aerostat.

Figure 5.8 shows the effect of the geometric horizon (curvature of the earth) on aerostat LOS. From this simple example, it is clear that increasing the altitude from the nominal minimum of about 200 m by a factor of 10 (to 2000m) only increases the LOS to another aerostat of the same altitude by a factor of about 3.2 (100km to 320km). This decreases the number of aerostats from four to a minimum of two.

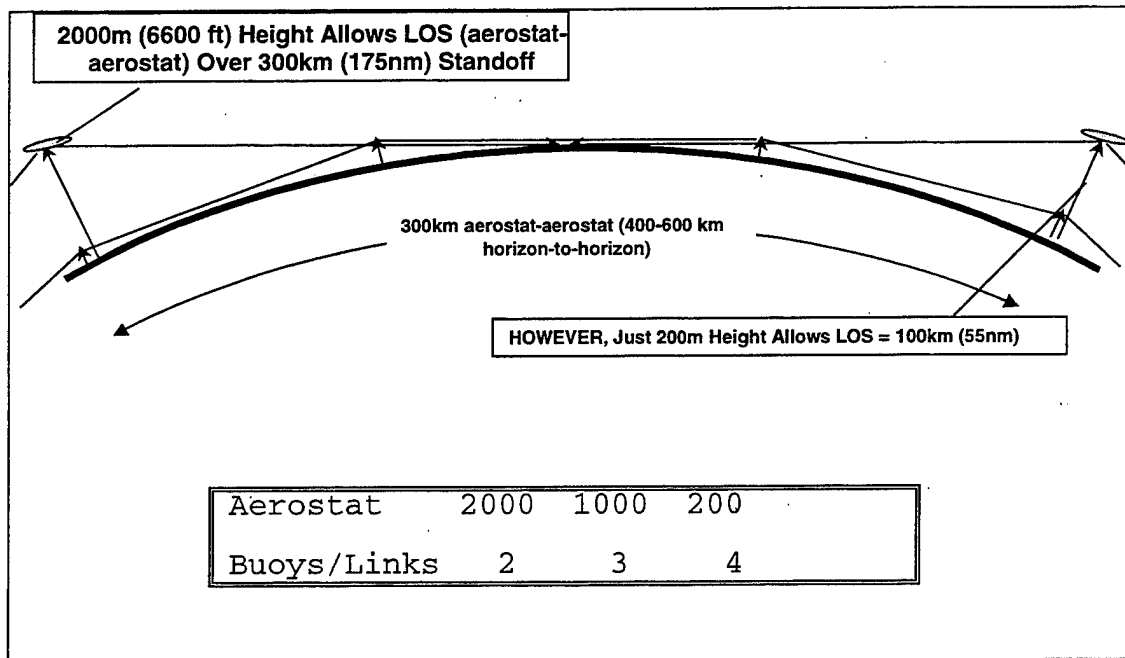

Figure 5.8. Effect Of Aerostat Altitude on Geometric (horizon-limited) LOS communications. [Ref. 26]

A single aerostat at 200 m provides an area of coverage of about 7800 sq.km. At least one ship of the OMFTS force would always have to remain within about 50 km (27nm) of that fixed aerostat location. For small OMFTS forces, one aerostat might be acceptable but, for larger seabase operations, the offshore vessels will want to maneuver up and down a coast for distances of at least a 100 to 200 nautical miles.

Furthermore, ships would need to maneuver from an extreme standoff distance (about 200 nautical miles) to as close as the horizon (about 50 nautical miles). Figure 5.9 illustrates this idea. It shows that about 3 x 2000-meter aerostats are required to cover the offshore maneuver area

plus one close to shore to provide the data relay. On the other hand, it would require about 14 x 200-meter aerostats offshore and an additional 2 to complete the relay to shore.

At first glance, it would seem that the higher altitude aerostats would be the most cost-effective approach to providing the required coverage. However, there are some

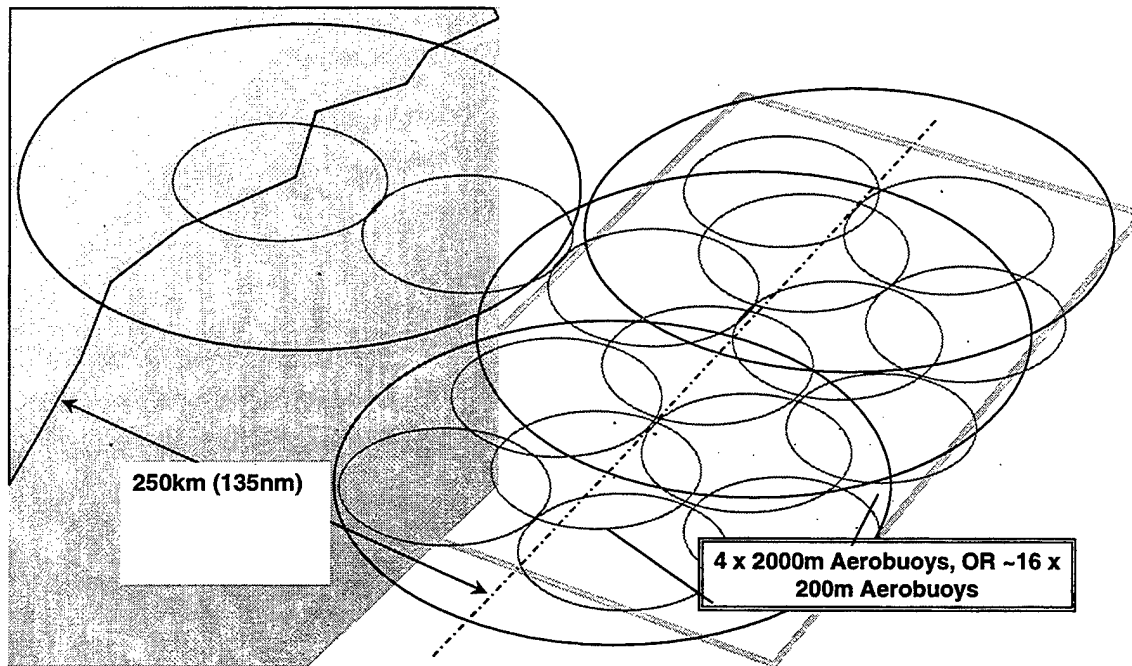

Figure 5.9 Coverage of The OMFTS Maneuver Areas. [Ref. 26]

interesting cost trades and other issues that have to be considered before deciding on the best approach and making the baseline altitude selection.

### 5. Altitude Versus Cost

Figure 6.10 portrays the purchase price of three classes of commercially available aerostats. The price is for the aerostat, riser, and tether handling system, and

communications suite, so it is not the total cost of an installed aerobuoy system with a floating mooring system (buoy or manned platform, mooring, power supply, etc.) However, the size and costs of the floating mooring system escalate dramatically with the size of the aerostat they have to support. Consequently, the relationship between altitude and cost (shape of the curve) will most likely be the same for the total aerobuoy system as it is for the bare aerostat.

The cost goes up non-linearly with the altitude. The following examples apply:

**a. 2000-Meter Aerostat**

The 2000-meter aerostat costs about six times as much as the 200-meter version. Given that relationship, a simple relay link of 4 x 200-meter aerobuoys would cost about one third as much as a link of 2 x 2000-meter aerobuoys.

**b. Grouping The Aerostats**

For the field coverage shown in Figure 5.9, the advantage for the smaller aerobuoys is not as great, but it is still substantial; a system of 16 200-meter aerobuoys would cost about two-thirds the price of a field of 4 x 2000-meter aerobuoys. In practice, it is not likely that it would be necessary to seed the entire field to produce 100 percent coverage with either the high-altitude or low-

altitude buoys. For a laydown of 3 x 2000-meter aerobuoys compared to a field of 8 x 200-meter buoys, the low-altitude version would cost about half the high-altitude version.

In any case, it is clear that the cost of hardware for the low-altitude version would be substantially less than for the high-altitude version.

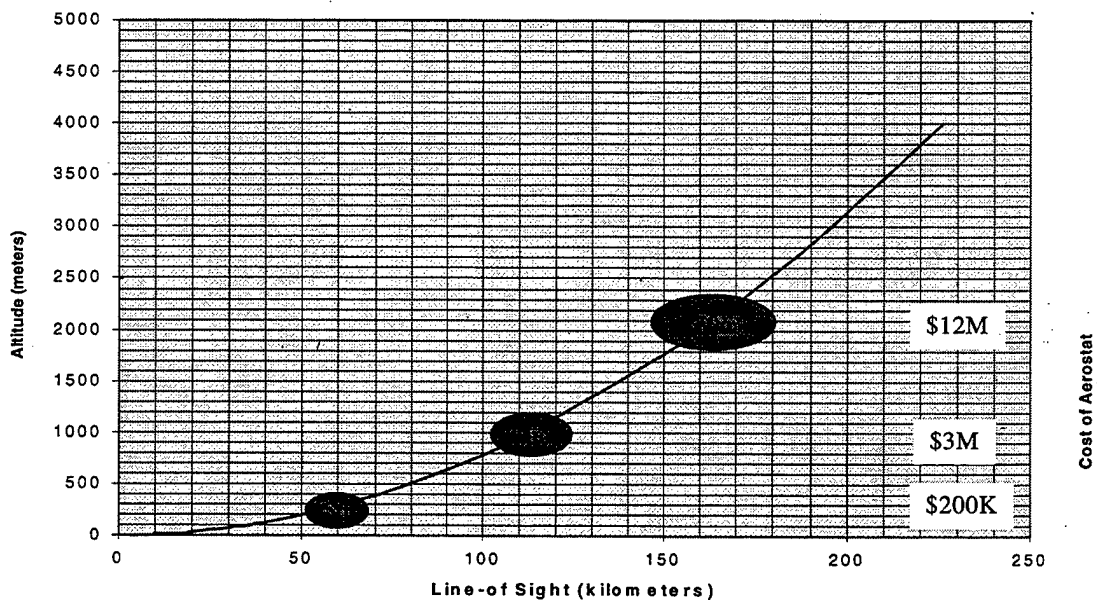

Figure 5.10. Aerostat Size versus Line-of-Sight Capability and Cost. [Ref. 26]

Beyond purchase cost, it is important to consider the other impacts of low-altitude versus high altitude ("more" aerobuoys vs. "less"). With the high-altitude buoys, tactical loss of a single buoy would mean loss of not only substantially more expensive hardware but also loss of

a much greater portion of coverage for OMFTS operations. Loss of one high-altitude aerobuoy would mean loss of coverage of as much as half the OMFTS operating seabase area. By contrast, loss of the smaller aerobuoys only represents loss of a small percentage of the covered area.

There are, of course, disadvantages to the use of a larger number of aerostats. Assuming a fixed, limited number of installation platforms in the area, it will take longer to install a large number of small aerostats than a small number of large aerostats. This may not be operationally significant, though, because it is likely that either type of aerobuoys could be installed as fast as the Seabase force could build up in the area. Even if only one aerobuoy were installed per day, the total field would be covered with small aerobuoys in about 1.5 to 2 weeks. In any event, the primary link to shore can be in place in no more than two days, so at least some high-bandwidth OTH communications would be in place from the very beginning of any sort of large-scale operations. However, the system with which SAIL will have to interface is the Marine Corps land aerostat program, the MCSLAP system.

Like SAIL, the MCSLAP program is required to operate in a variety of environments, from small platforms. Under this program, the Marine Corps have chosen the commercially available 15-meter aerostat design as their baseline. If SAIL uses that same design, it will be

possible to standardize across both systems and obtain cost reductions through economy of scale in purchasing, standardized spare parts, standardized operator training, and employment schemes.

The smaller aerostats are also better in that they can be transported and installed from a variety of small surface platforms that are expected to be on-site early in (and throughout) OMFTS operations - especially the LCU and LCAC. The requirement for large launch/recovery equipment precludes the use of larger aerostats from other than dedicated vessels (converted offshore workboats).

#### **6. SAIL Selection**

In conclusion, the baseline choice for the SAIL aerostat is the commercially available 15-meter aerostat; the same type used by the Marine Corps Static Lighter-Than-Air (MCSLAP) program. The MCSLAP program already has a Mission Needs Statement that reflects this requirement. Although the MNS says that the Marine Corps requires aerostat technology to meet their entire OMFTS mission, the MCSLAP program to date has focussed on solving the over-land communications problems. On land there is not only the geometric horizon but also all sorts of natural and man-made vertical obstacles to overcome (trees, mountains, buildings, etc.). The MCSLAP program does not provide aerostat technology to link OTH at sea. Integration of both programs

would provide optimal OTH communications in addition to SATCOM.

The choice is clearly the lowest cost and has major advantages in standardization with MCSLAP, insensitivity to loss in tactical operations and maximum versatility in installation and adaptation to varying OMFTS scenarios. The details of the selected baseline aerostat are described in the following sections.

### 7. Undersea SDFO Costs Versus Aerobuoy Relays

Parameter	AEROBUOY Relay	SDFO Cable + AB	SDFO Cable Link
Cost Per Mission Per Km	Cheaper If AB's Have Long Life (>4-5 missions)	Cheaper If AB's Are Rapidly Expended	Generally Cheaper For Long Festoon Distances (no AB at end of cable)
Weather Sensitivity	Moderate (many AB's means more exposure to weather spectrum)	Low (at-sea AB still exposed to weather)	Very Low (SDFO sees no weather except at Shore Landing Cable)
Security Risk	Moderate (Encrypted transmission and LOS make interception difficult)	Low (some interception at seaward AB possible)	Very Low (extremely difficult to intercept SDFO data without detection)
Installation Time	Lowest For Short Distances, Highest For Long Distances	Highest For Short Distances, Lowest For Long Distances	Highest For Short Distances, Lowest For Long Distances
Vulnerable	Some vulnerability to EM jamming, surface attack/vandalism and mid-water or bottom fishing	SDFO vulnerable to bottom fishing. System has vulnerabilities of both AB and SDFO, but fewer AB's exposed.	SDFO vulnerable to bottom fishing.

Table 5.1. Parameters for Selecting Aerobuoy Relays Vs. SDFO Cable Links. After [Ref. 26]

The SDFO link and aerostat relays are very different systems for providing OTH high-bandwidth links between the Seabase platforms and maneuvering units ashore. Each has



its own strengths and weaknesses that are different from and complementary to the other system. Table 5.1 summarizes some of the key parameters by which the two approaches can be usefully compared. Note that SDFO Cable Links may be used between shore and an offshore aerobuoy, or directly from shore-to-shore (festooning).

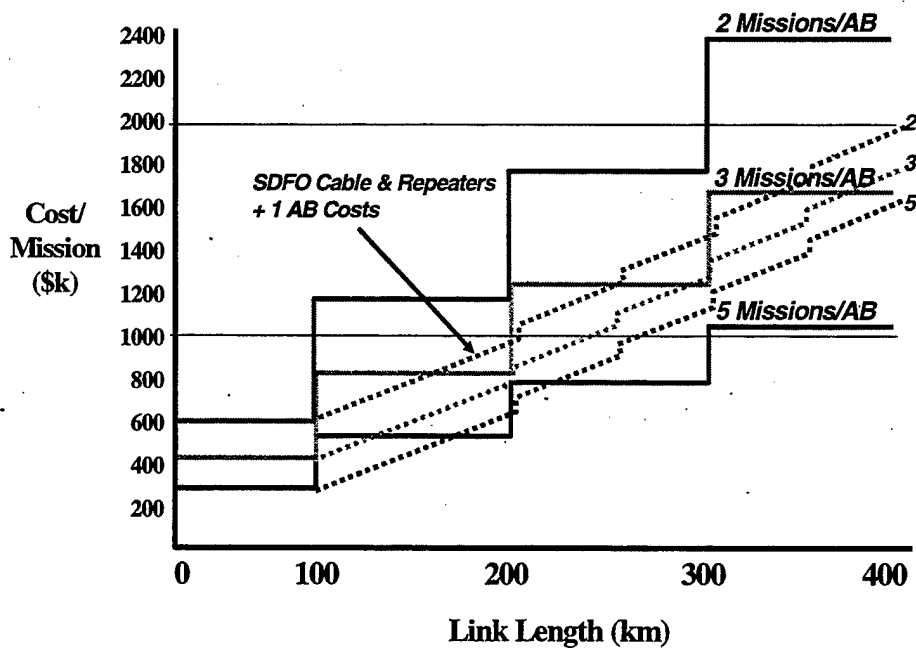

Figure 5.11. Comparative Costs of AB Relays vs. SDFO Cable.

Figure 5.11 shows the cost comparison of AB Relays vs. SDFO Cable Links. For the SDFO links it is assumed there is always one AB used at the seaward end, which is why there is a band of cost estimates. The cost of a cable system starts with the cost of at least one AB and grows with distance because of added cable and repeater costs. Repeaters are added at an estimated rate of one per each 50 km after the

first 100km from the buoy (where power is more available). The SDFO cable cost is based on the present ADS costs. SDFO cable is not economically reusable; it costs more to recover, refurbish and repack it than it does to build new cable. Therefore its costs per mission change only with the cost per mission of the seaward AB to which it is connected (and of course the length of the OTH link). Note that the relative advantage of one approach over the other changes substantially with the assumption regarding how many missions each AB will survive.

The figure shows that if the total cost of an AB can be amortized over more than 4 missions then it can be cheaper to use AB relays for an OTH link than SDFO cable (for long OTH distances). On the other hand, if each AB is only useful for 2 missions or less, the advantage goes to the SDFO cable. For a 3-mission AB life, the costs are about equal. These are only preliminary cost estimates. The actual costs will vary from these numbers but the tendency is clear.

The bottom line of the cost analysis is that for most systems, cost is not likely to be a major driving factor in the operational selection of SDFO Cable Links v. AB Relays. Instead, the selection will be based on their relative survivability, the expected degree of maneuverability and relocation required for a mission and the other factors outlined in Table 5.1.

## 8. Aerobuoy Relays vs. Undersea SDFO Cable Links

Figure 5.12 and Table 5.2 represents the estimated time to install various lengths of AB Relays. The minimum length is about 100 km (one AB) and the maximum is 400 km (4 AB's). The assumptions behind the analysis are as follows:

Installation of an AB is a six-step process that requires:

- Load out of the AB at a Seabase ship (except the first, which is preloaded on the LCU or LCAC).
- Transit from a Seabase site to the location of the first AB (depends on Seabase-to-AB site distance)
- Install the moored buoy.
- Inflate the aerostat and flying it, transferring the aerostat to the buoy (3 hour total)
- Returning to the Seabase (except for the last AB).

All classes of landing craft will be in great demand during the maneuver phase ashore. The alternatives are to minimize use of these craft to only mission critical functions to support aerostat installation. For reference, the U.S. Coast Guard has established procedures, experience, and equipment for deep sea moored buoys that are available to the later assault follow-on stages on littoral operation.

The slowest installation is from an LCU, which is assumed to transit at 12 knots (22km/hr). Reload time is

assumed to be 3 hours. Table 5.2 shows that the total installation time ranges from a low of less than a half day for a single AB to as much as about 3.5 days (assuming 24-hour ops). Even allowing for weather delays, crew changes and other delays, a max-length AB Relay could easily be installed in less than a week, using just a single LCU. With multiple LCU's or use of an LCAC the entire link could reliably be installed in just 2 to 3 days.

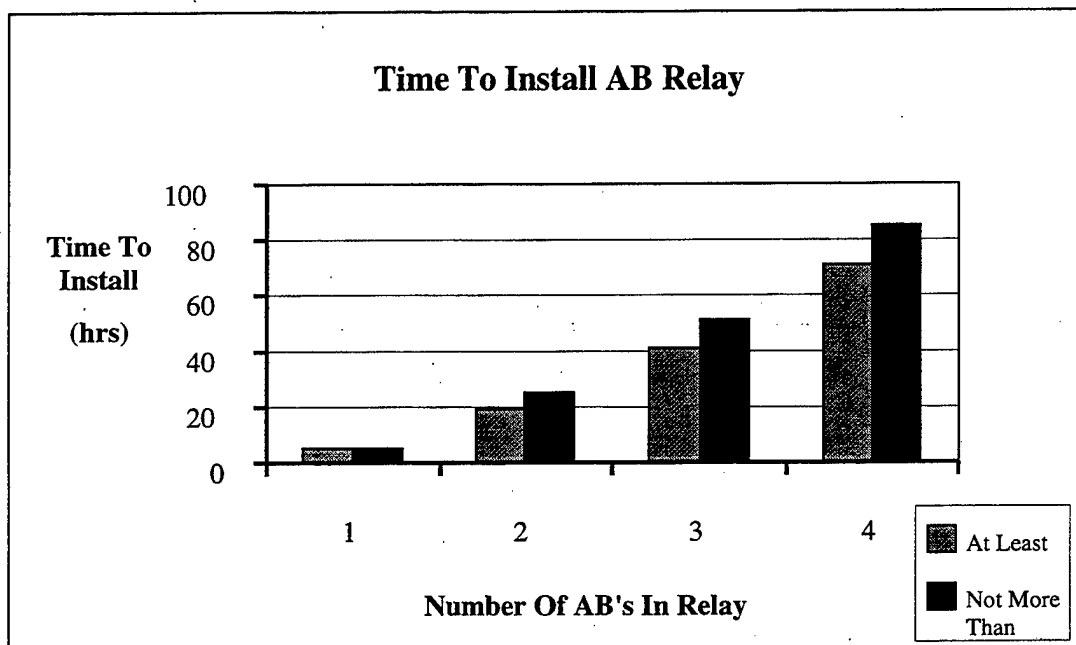

Figure 5.12. Time To Install AB Relays. [Ref. 26]

### Time To Install AeroBuoy Relays

No. AB's	AB#1		AB#2		AB#3		AB#4		TOTAL(hrs)	
	Lo	Hi	Lo	Hi	Lo	Hi	Lo	Hi	Lo	Hi
1	5								5	5
2	11	15	8	10					19	25
3	19	23	14	18	8	10			41	51
4	27	31	22	26	14	18	8	10	71	85

Assumes one LCU transiting at 12 kt (22km/hr), AB install takes 3 hrs, AB spacing 100km.  
 Reload assumed = 3 hrs.

Table 5.2. Time To Install AB Relays. [Ref. 26]

Figure 5.13 displays a similar type of estimate for SDFO Cable Link installation. In this analysis, SDFO installation speed averages 10 knots over the trunk length, plus 3 hours to install the AB and connect to it. Since either LCU's or LCAC's can carry cable all the way to a beach, there is only about two hours additional time to offload the end and connect it to an onshore junction.

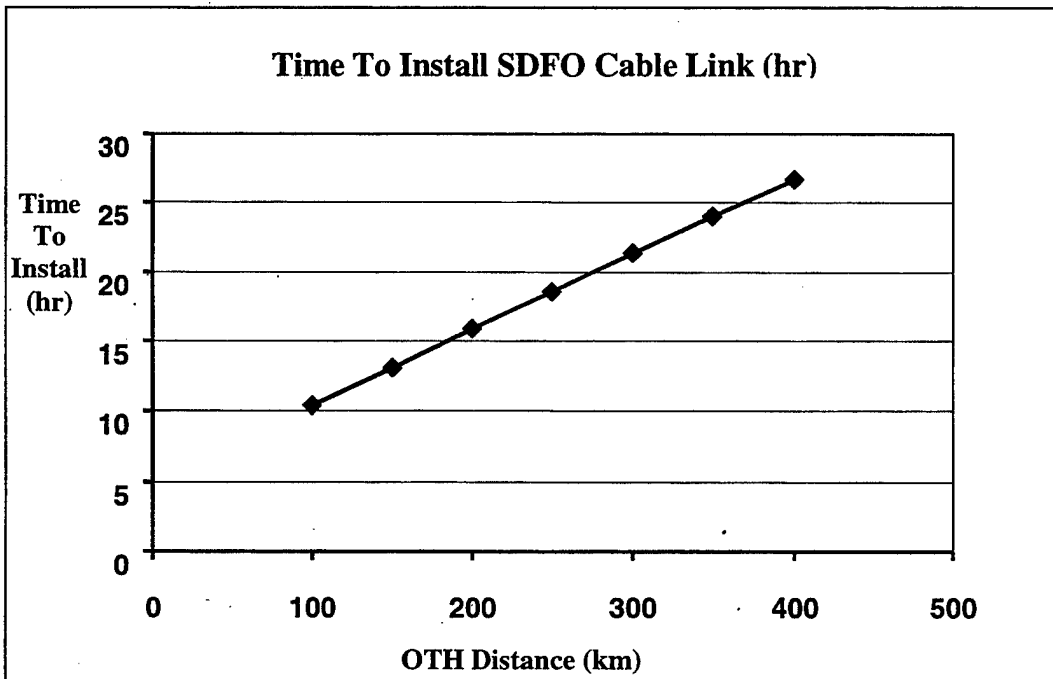

Figure 5.13. Time to Install SDFO Cable Link.

It is evident from this time comparison that the SDFO Cable Link will generally be a significantly faster installation when the total link length is greater than just one AB. The time difference can be as much as two and a half days for the very long OTH distances. In some cases this could be important depending upon the landing force mission.

It also is clear from these analyses that the installation of SAIL OTH communications links can certainly be expected to keep pace with the normal buildup of Seabase and other OMFTS forces in a regional littoral conflict. The first short link can be in place in a matter of hours after arrival on the site of the first major amphibious ship (carrying an LCU or LCAC). A complete OTH link could be in place within half a week and there could even be duplicate links in place in as little as one week.

#### **9. SAIL Concept of Operations**

The basic premise for SAIL employment is presented in the following narrative:

Navy ships will be in a Seabase formation at a nominal 200 nautical miles offshore. In the midst of the Seabase will be a tethered aerostat(s) that will be carrying a communication relay payload(s). The aerostat will be flying from a floating mooring platform that will either be a craft of opportunity or a buoy (the aerostat and the buoy together, termed an aerobuoy). The aerostat relay station

will be the platform providing the communication link between the ships' UHF communications and a fiber optic cable trunk running from the Seabase to the shore, or via RF wireless LAN relay link. The aerostat will receive ship communications and send them along the fiber optic cable to the shore.

#### **D. SYSTEM INTEGRATION**

The integration of ADNS, SAIL, NTDR, within the Marine Corps TDN is an area of research that is presently and in future years will be explored by various organizations such as NFESC and SPAWAR in conjunction with the U.S. Marine Corps Warfighting Lab exercise and experiment programs, and the U.S. Navy Doctrine Command.

During the initial introduction of forces in the littorals, the LRAM in support of a MEU could possibly consist of units operating with radios based on the IEEE 802.11, wireless networked radio standard, and portable, manpacked SATCOM links. Aerostat relay sites seaward would provide OTH connectivity to sea based command and control via the wireless link. As the level of conflict increases, this may necessitate the need to move command and control ashore. In which case the TDN is established using ADNS as a means to optimize available communication resources. A commensurate increase in conflict intensity will require a transition up to a MEF size MAGTF, accompanied by a parallel

increase in shipping, and communication capability. Figure 5.14 graphically portrays this scenario. Initial architecture and integration concepts and options are explored in the following Chapter employing commercially available modeling and simulation software.

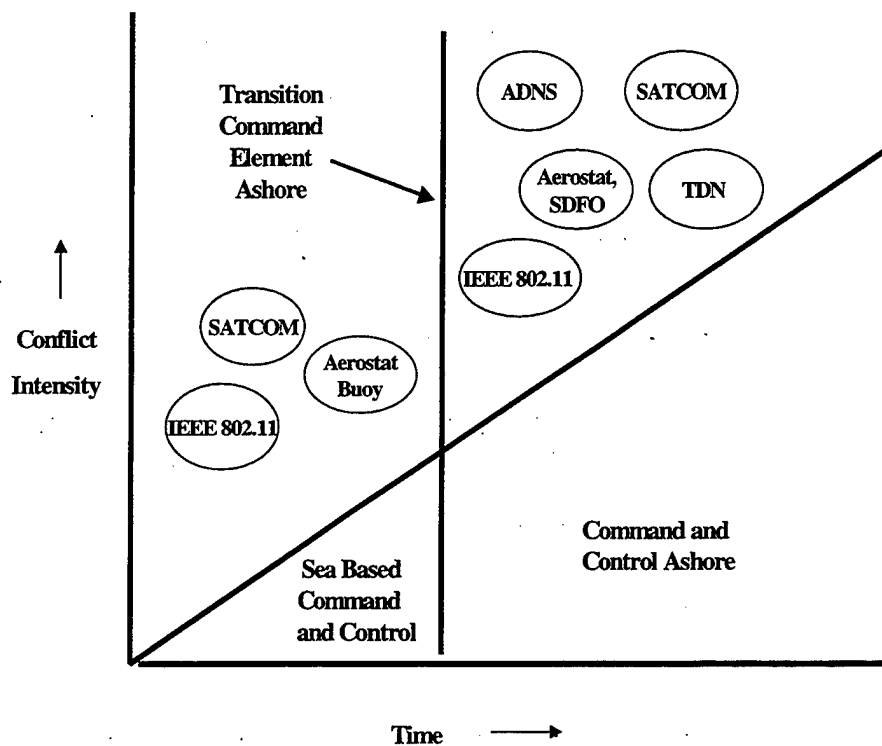

Figure 5.14. LRAM Employment Scenarios.



## **VI. SUPPORTED CONCEPT OF OPERATIONS**

### **A. OMFTS SCENARIOS**

One OMFTS concept under development by the U.S. Marine Corps Warfighting Lab envisions small, highly mobile teams dispersed over a battlefield. These "reconnaissance assault platoons," or RAPs (the teams are referred to by several different names) would cover an area, identify critical targets, and engage particular targets by calling in precision fires. RAPs are conceivably Platoon to Company size units on foot or mechanized that deploy ashore, separated at maximum distances of 200 miles from their sea based command and control. The idea is to achieve the combat power of a large force spread over the entire battlefield without offering a large, fixed target against which the enemy can retaliate. Again, most of the support for these units - command and coordination, fires, and sustainment - will remain at sea. [Ref. 1 and 2]

#### **1. Network Architecture for The Assault Phase**

During their assault phase they will carry minimum supplies and assuredly require logistics support and sustainment immediately upon engaging hostile targets. Their principal communication means are RF line-of-sight (LOS) via networked radio system based on the 802.11 standard, with relay sites inland, and buoyed at sea that allow them to

communicate to their combat operations center (COC) at the sea base. In some instances aerostats are connected to anchored sea buoys to increase transmission ranges. Figure 6.1 portrays one possible means of depicting this scenario.

## **2. LRRAN Architecture for Sustaining OMFTS**

If hostilities increase, follow-on actions are usually necessary, highly mobile combat service support detachments (CSSD) inevitably will move ashore, and fall in trace of maneuver units. These mobile CSSDs also will employ RF LOS, NTDR radios. Units may redeploy back to the sea base, awaiting further follow on missions, or remain ashore, in which case would require a robust combat service support (CSS) effort for sustained duration.

The current CSS doctrine, as presently tested by the U.S. Marine Corps Warfighting lab, positions additional combat service support (CSS) units at forward operating locations close to maneuver elements with sustenance immediately necessary to further prosecute military action. For example, borrowing from lessons learned from Russian Army operations in Chechnya (Grozy), ammunition and medical support caches are placed well protected, hundreds of meters from the forward battle area, along with fuel and water. Highly mobile CSS elements are located or echelons immediately back from the battle area ready to react to immediate requirements. Small landing support units assist

distribution efforts, communicate to the supported ground units via RF LOS, NTDR radios.

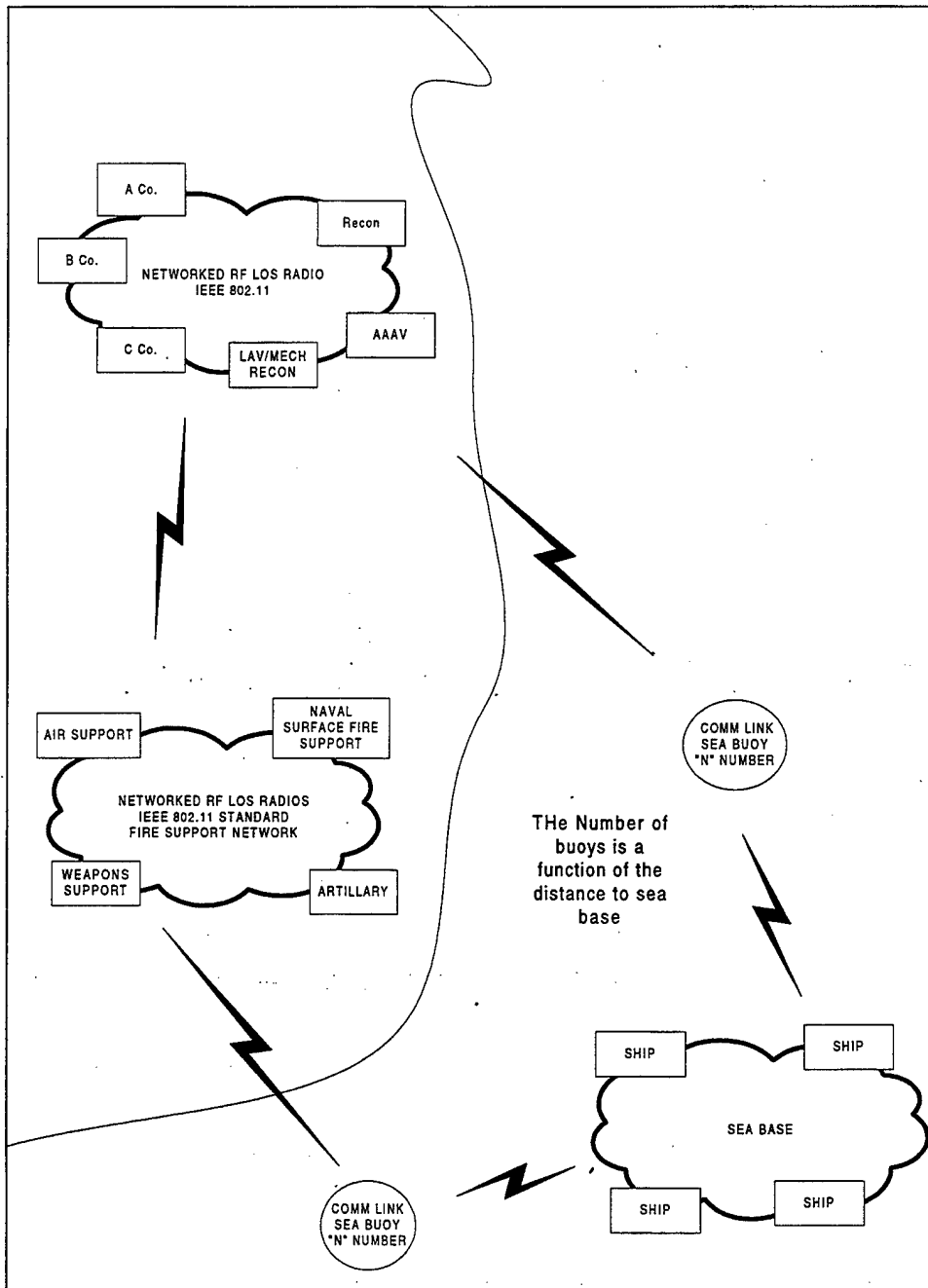

Figure 6.1. Initial OMFTS Network Architecture.

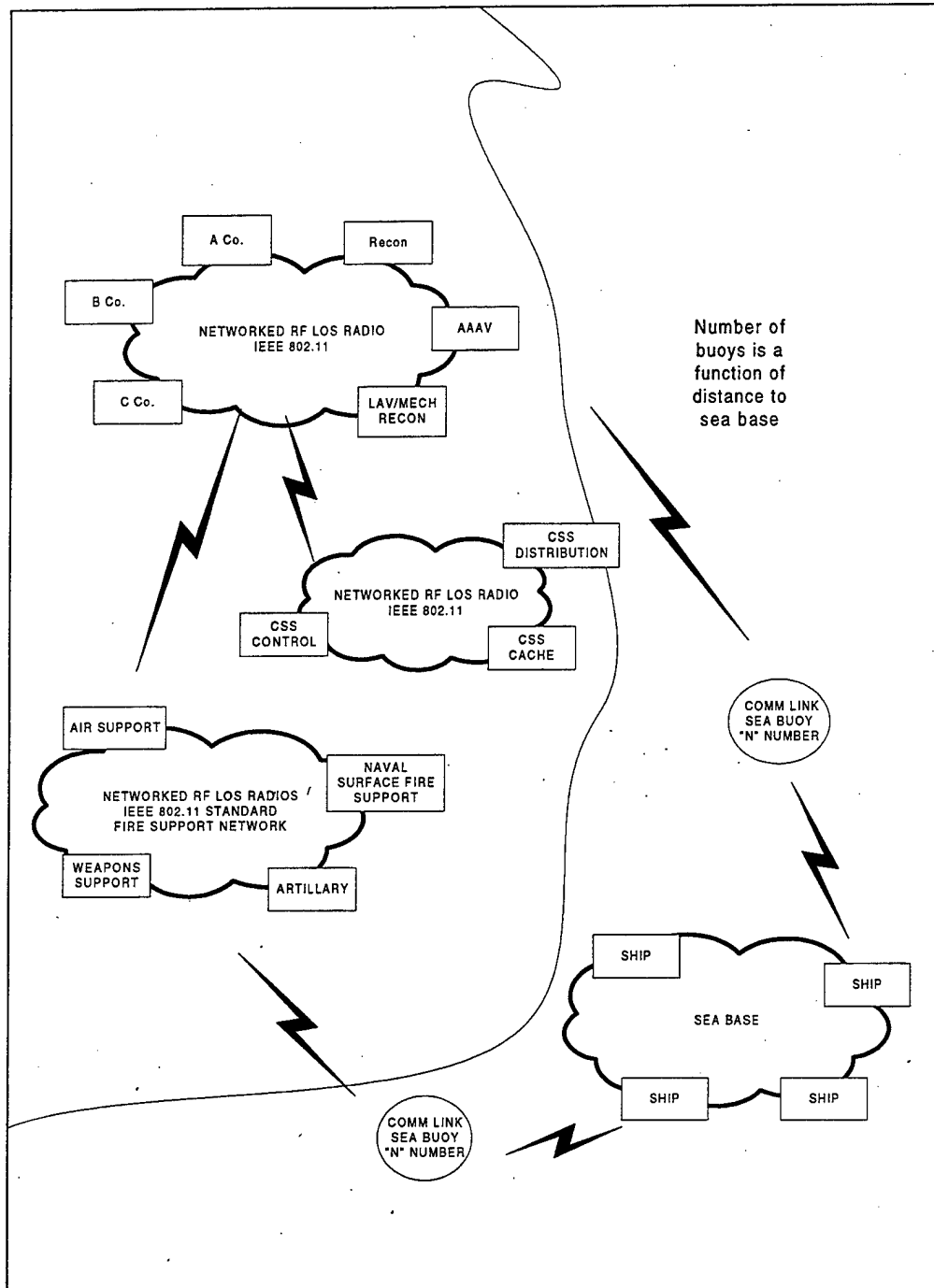

Figure 6.2. Initial OMFTS Network Architecture.

The decision to position supplies and logistics assets ashore is time dependent on how desperate the tactical

situation is at the time, or is perceived in the near future. However, it is otherwise assumed logistics support will remain miles at sea at the seabase. An increase or robust logistics operation ashore will require the introduction of forces necessary to improve the tactical situation as landing objectives are secured, and follow on missions assigned, but also to secure areas to manage and administer supply dumps, and transportation routes.

### **3. LRRAN Architecture for Command and Control Ashore**

As forces continue their missions and the tempo of operations increase, the inevitable decision is to transition tactical command and coordination from the sea base to the shore for sustained operations. Once this decision occurs, the COC is established ashore with the immediate requirement to conduct OTH communications back to the sea base. A commensurate demand in communication assets, and bandwidth will accompany this change.

Implementing ADNS via fiber optic cable through the surf zone, out to sea via an airborne buoy and aerostat (SAIL concept) will provide LOS relay connectivity to the sea base, or in other cases provide a direct link to the various SATCOM systems employed to support DOD. The NTDR land relay and sea relay buoys should remain in place to provide assured network connectivity and back-up throughout the littoral region. Figure 5.5 from chapter five can be used again to accurately portray this concept.

In a mature theater of operations, sustained operations ashore require an increased infrastructure to support operations magnitudes higher approaching the scale of a land campaign, such as a MEF conducting a Maritime Prepositioned force (MPF) offload. In this case, additional SAILS are deployed to support shore based tactical commands and logistics operation over shore operations (LOTS) commensurate with required communications to support a major conflict.

THIS PAGE INTENTIONALLY LEFT BLANK





## VII. LRAN MODELING AND SIMULATION

### A. MODELING AND SIMULATION

This chapter explores the use of modeling and simulation as a tool to aid in understanding LRAN communication architectures that support the OMFTS scenarios presented in the previous chapter. In addition, modeling is useful in characterizing the interoperable nature of these systems toward an LRAN solution. The models and the supporting employment scenario are based on research the author performed while investigating OMFTS doctrine and the concept of operations employed by the U.S. Marine Corps Warfighting Lab Sea Dragon experiments in such exercises as Urban Warrior, and Hunter Warrior. Three models were developed and tested based on the 802.11 wireless standard, employing a PC based, objected oriented modeling and simulation tool called **Extend®** (version 4.03) developed by Imagine That! Incorporated. As an easy-to-use graphical simulation tool designed for decision support, Extend allows the user to model complex discrete or continuous systems while varying performance parameters. [Ref. 32]

#### 1. Background and Terminology

A model is a logical description of how a system performs. Simulations involve designing a model of the system and carrying out experiments on it through time, and

measuring the behavior of the model. Models also enable one to test hypotheses at a fraction of the cost without actually undertaking the activities to construct a real world physical representation of the system. This is extremely valuable in the initial concept and development of any new system and its supporting principles from which it is based. It allows one to evaluate ideas and identify inefficiencies before expending capital and resources to the actual final product. Simulation is also important because it is used to: gain insight and stimulate creative thinking toward a concept, identify problems before implementation, confirm all variables, and finally, to strengthen the integrity and feasibility of a concept.

A principle benefit of a model is that design begins with a simple approximation of a process that is gradually refined as understanding of the process improves. Consequently, models are always changed to improve accuracy.

There is an extensive amount of written literature on network modeling and simulation. This chapter goes into some details and specifics as it relates only to the models. However, extensive background isn't essential for the purpose of this thesis. For further reference, the author gained tremendous insight from the works and ideas in books by Desrochers Fortier, and Schoemaker, and also in the completed thesis work by Davis, and Rieffer. [Ref. 33,34,35, and 36]

## 2. Software

There are a staggering number of commercially available modeling and simulation tools. A comprehensive review of these tools is provided by Reiffer [Ref.36] However, Extend was chosen because it is a popular tool for high level, concept design. It does not require any special type of equipment beyond a 486 Pentium, or Pentium Pro computer. Extend runs on the following operating systems: Windows 3.1 or 95 by Microsoft or MacIntosh or Power MacIntosh by Apple. Furthermore, it is user friendly and inexpensive (this is sometimes entirely subjective). Past experience with this tool and Extend's simple graphical interface make it easy to build functional models. Extend is used extensively by Navy organizations conducting research in OTH communication concepts, such as SPAWAR and NFESC, and the Naval Postgraduate School. It presents a dynamic simulation environment, which supports both discrete and continuous event process modeling and combined discrete/continuous event process modeling and simulation. Extend uses pre-built object blocks that are the foundation of an Extend model. They emulate user-selected functions, actions, and processes of the model. For ease of use, blocks are grouped according to function. This makes it easier for new users to quickly grasp their supporting functionality.

Represented by icons, blocks are assembled by "dragging and dropping" from the GUI tool bar to the working space.

The user then connects the blocks in process order, or desired sequence, while also entering performance parameters, or behaviors, into each block through its associated dialog page. Animation allows items to be followed during simulation. As the model grows and becomes more complex, the user can group blocks, and form process hierarchies with associated inputs and outputs in and out of the system. Simulation results are displayed using graphs, tables, sensitivity analysis, and user-developed notebooks for input and output of performance data. [Ref. 32] Because network activities are event driven, discrete event simulation is the design basis for the LRAN model scenarios.

### **3. Design Steps**

The scenario based network models follow the following design sequence: define the network based on the physical architecture required to support the scenario; develop and build the model through a step wise, iterative process that includes representation of links, nodes, and interfaces, run the simulation, analyze the results, make changes to the model; and draw conclusions based on model results. The culmination of this process is represented in the model block diagrams contained in Appendix C. What follows is a discussion of the simulation results.

## **B. THE EXTEND MODELS**

### **1. Design Parameters**

The design parameters modeled for the initial introduction of forces in the OMFTS scenario include bandwidth loading based on user input data rates, delays, and the number of collisions in the 802.11 wireless network.

Figure 7.1 portrays the high-level system decomposition of the 802.11 network to support initial implementation of OMFTS forces. In this particular model, there are four functional components to the model: the user groups, the network, the SAIL, and the sea base. It assumes that the optimal bandwidth, or data rate is when all users, or in this case, mobile tactical units are acting independent of one another, with sea based command and control, logistics support, and fire support. The user group is selected based on the Marine Corps' pyramid command and control organizational structure of "threes." For example, the basic infantry unit is the fire team. There are three fire teams per Infantry squad, and there are three squads per platoon. Each infantry company has three platoons, with a small company headquarter element with fire support and close air support coordination capability. The force is mobile using either MV-22 Ospreys, AAV's, or light armor vehicles. The network support concept was displayed in the previous network diagram in Figure 6.1. In traditional employment,

this is a structure that optimizes span of control for unit leaders.

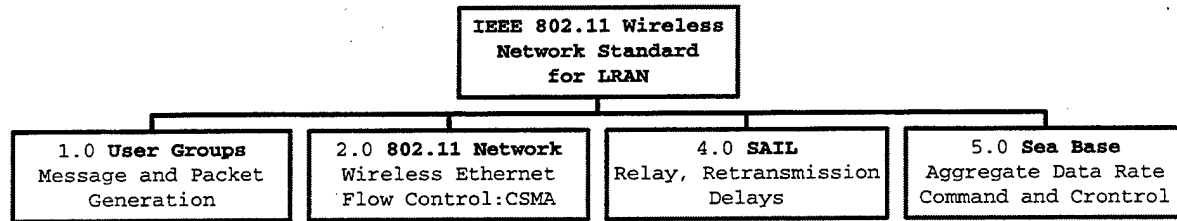

Figure 7.1. System Decomposition of the IEEE 802.11.

## 2. System Decomposition

Figure 7.2 represents the transition from the functional decomposition structure chart to the Extend model diagram of the 802.11 Wireless Ethernet Standard designed to support OMFTS forces. This includes user functions for message to packet generation based on the 802.11 standards, the network itself employing carrier sense multiple access (CSMA) for flow control, propagation delay as a function of message size and bandwidth at the SAIL relay points, collision detection, and the Sea base command and control output source for the results of the simulation.

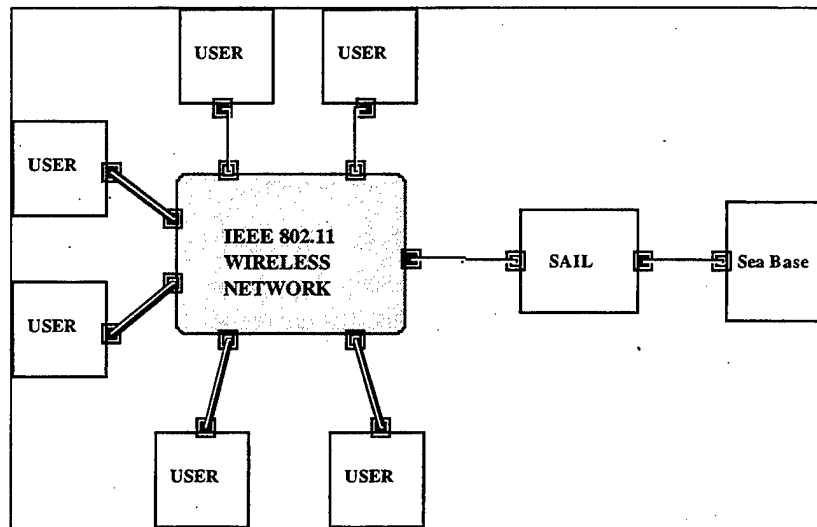

Figure 7.2. L-RAN Network Diagram Model using Extend.

### 3. Simulations for Sea Based Command and Control

The simulations to test the 802.11 wireless model varied the message rates for a network consisting of a six-user node group, and then for a network comprised of two, six-user node groups (as in Figure 7.2), and finally for three, six-user node groups. For purpose of the scenarios, the single, six-user node group simulated six independent units operating in the initial stages of an OMFTS operation. The two, six-user node groups represents an increase in ashore strength similar to a mobile infantry company, with communication links to aviation and fire support teams such as NSFS, and close air support (see Figure 7.3). The assumptions for both scenarios are summarized as follows:

- Command and control is sea based.
- Units operate independent of one another. Therefore,

the optimal network loading condition exists when all users are transmitting what appears simultaneously to the sea base. Communication with another unit is on an as required basis to coordinate maneuver and fires.

- Message traffic is relayed to the sea base via an autonomous aerostat or sea buoy used to relay traffic OTH to the sea base.

- The bandwidth is equal to the 500 KBPS rate for the NTDR radio. This value can be varied within the model based on other types of wireless radio technology.

- The generation message rates were set at ten messages per hour, and incremented by ten, for three tests runs to a final rate of 30 messages per hour. These rates were based on exercise rates established from exercise Hunter Warrior [Ref. 37] The model allows for rates that can be arbitrarily selected based on the tactical scenario.

- Message generation, message length and message inter-arrival times are random. Therefore, the performance output is based on random behavior of network nodes.

- Commercial performance indicators are available for network performance. Acceptable delays for current technologies vary from 0.1 sec for voice, 0.1 to 10 sec for file transfers, one to ten minutes for e-mail (although less than 0.1 sec is the average on most LANs), and 0.1 to minutes for video. [Ref. 24]



A third scenario introduced a logistics support node to exemplify small combat service support teams operating supply caches well forward, close to the forward battle area. The resultant architecture is comprised of three, six-user node groups operating on one network through the SAIL to the sea base. Due to the interoperable nature of the standard, this could be easily linked via a router to the Marine Corps TDN or other systems, such as SATCOM. For example, there are absolutely no reasons the 802.11 signal couldn't be multiplexed and routed through a point-to point system such as INMARSAT. However, throughput would degrade to 64 KBPS.

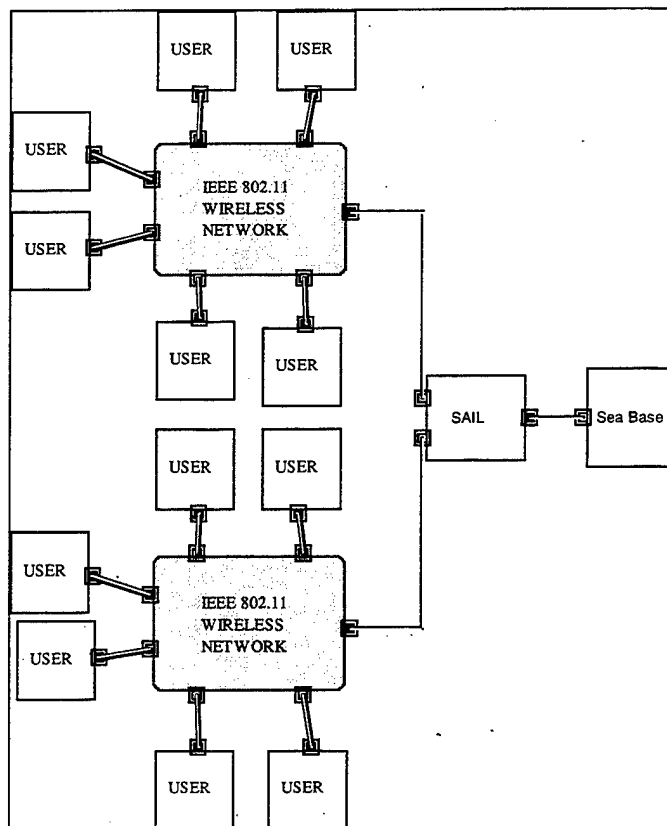

Figure 7.3. Extend Model for Two, Six Node User Groups.

#### 4. Sea Based Command and Control Simulation Results

Table 7.1 contains an example set of results for the single, six-user node simulation. Table 7.2 is the two, six-user node simulation that exemplifies the build-up of combat forces ashore, and Table 7.3 is the three, six-user node simulation that takes into account initial logistics support.

Message Rate (msg/hr)	10	20	30
Throughput (bps)	287	307	390
Delay (sec)	1.453	2.727	3.343
Collisions	49	52	67
Packet Count	153	164	208

Table 7.1. Simulation Results for one, six-user node.

Message Rate (msg/hr)	10	20	30
Throughput (bps)	326	332	368
Delay (sec)	1.678	2.991	3.515
Collisions	53	67	78
Packet Count	174	178	196

Table 7.2. Simulation Results for two, six-user nodes.

Message Rate (msg/hr)	10	20	30
Throughput (bps)	345	447	467
Delay (sec)	1.964	2.202	3.878
Collisions	60	72	87
Packet Count	184	238	249

Table 7.3. Simulation Results for three, six-user nodes.

Each simulation emulated a one-hour test of the network: In real time, each simulation required approximately eight hours to complete. This was due in most part to PC processing speed, and the complexity of the model itself, and the number of steps required to process a packet through the network. Bandwidth plays the largest role in reducing delay time followed by flow control (the 802.11 standard employs CSMA), followed by user message priority. The

message size used in this model varied from thirty-four bytes (overhead) to one mega-byte. The chosen values were based on the 802.11 standard overhead and common file size for digital imagery data. For example, a typical file size for a digital camera employing the Joint Photograph Expert Group (JPEG) standard file format is approximately 150 kilobytes in size. A bit map image of like proportions is approximately 500 kilobits. Text messages are obviously smaller than imagery. Furthermore, with the advent of "Voice Over Internet Protocol" (VoIP), the model assumes voice traffic is of equal message size to imagery and plain data. However, like bandwidth, the message size can be arbitrarily selected to test various scenarios within the model itself.

Figure 7.4 is a graph that plots throughput versus the selected message rates for the one, two, and three, six user node simulations. In each case throughput rate is generally increases with addition of more users. At the six-user three node case the model approaches its maximum bandwidth capacity. When the tests were run, the throughput rate leveled off, and network delay increased. Simulations with more than three nodes exceeded the bandwidth breakpoint of 500 KBPS set for the simulations.

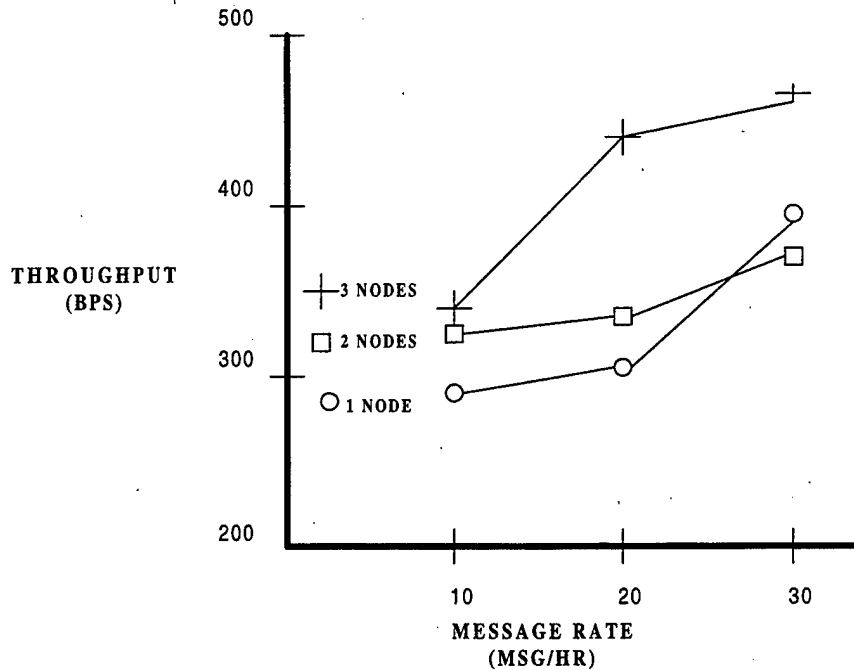

Figure 7.4. Message Rate Vs. Throughput.

#### 5. Conclusion of Simulation Results.

The goal of this analysis was to determine the performance characteristics of the 802.11 network based on its application to support the initial employment of forces in an OMFTS scenario. Further tests using the network model would include varying the system bandwidth to test other types of wireless systems based on the emergent 802.11 standard. For example, this model assumed the system bandwidth was 500 KBPS for the NTDR system discussed in the previous chapter. The model user can easily change it to lower or higher rates.

Another test is to implement message prioritization for flow control in addition to CSMA. In concept, this allows

messages with the highest priority are routed through the network first, before others. This model was designed to support this implementation; however, it was not tested for the purposes of this study. Another option is to explore the implementation of multicast message routing into the model.

As discussed in Chapter five, extensive research and test and evaluation is presently conducted in the area of OTH communication systems other than SATCOM. Consequently, another benefit of running the 802.11 model is to take exercise, or experimental message rates, and run a series of tests just as it was performed in this analysis. This serves as an inexpensive means to analyze trade offs between the respective system candidates prior to expanding resources and capital on exercises and field tests.

Presently, the doctrinal discussions address only the employment aspects of OMFTS vice redeployment. The opposite of course is to consider redeployment of units back to the seabase, and the essential communication requirements to accomplish this critical operational concept. For example, the administration and management burden of accounting for personnel casualties, degraded equipment status, unit locations and egress routes conceivably can require additional assets and communication systems to manage this aspect of OMFTS doctrine. As a result, doctrinal research and discussion is required in this area prior to model implementation and testing.

## **6. The Marine Corps TDN and ADNS Model.**

This chapter focused on model development and simulation of the 802.11 wireless standard that would support the introduction of tactical forces in the OMFTS environment. Likewise, the same design and development process is necessary for an extensive model and simulation analysis incorporating the Marine Corps TDN with ADNS. Concurrent with this research, Misiewicz incorporated this concept into his master's thesis work through development of an Extend model to portray the integration of ADNS with existing and future SATCOM systems throughout the carrier battlegroup (CVN) and amphibious ready group (ARG) level of operations. [Ref. 38] Because his work was ongoing at the same time as this research, a subsequent review of his model and results is necessary prior to incorporating the Marine Corps TDN, and ADNS system model as a subnet to the CVN and ARG model. In this case the command and control structure transitioned ashore essentially competes for network usage with other sea based users such as ship within the carrier battle group, and the amphibious ships. Rationally, the three are a magnitude above initial OMFTS or MEU employment concepts. In this respect it is a comparison of operational communication support systems vice the tactical communication system modeled in this thesis. In addition, the command and control network ashore and the ships link themselves to a significant number of other communication

systems that reach back and operate out of the littoral environment to the national command, Joint Chiefs of Staff, or service level information entry points. Importantly, if any of the systems integrated into ADNS fail, the SAIL system, depending on the type of communication system it is intended to support would represent another path of the Marine TDN/ADNS system out to the ARG, Carrier battle group, to the Joint Task Force Commander, so the command element could still send and receive critical tactical information.



## VIII. CONCLUSIONS AND RECOMMENDATIONS

### A. SUMMARY

In summary, a littoral region network solution must consider an open standards architectural approach to optimize multiple communication paths between forces ashore and sea based elements. Each node in the network must avail itself to multiple possibilities in the event of failure. To this end, the LRAM design should continue to couple the system development process with the doctrinal precepts for littoral operations.

To support this concept, one OMFTS scenario was researched and explained here in thesis study based on extensive work conducted by the Marine Corps Warfighting Lab. In general, the integration of the TDN with the wireless 802.11 standard, ADNS, and the SAIL program provide an alternative to satellite communication systems, and appears fully worthy of future research.

LRAM implementation begins with deploying the wireless mobile communication platforms with highly mobile maneuver forces ashore. Message traffic is relayed OTH, via a relay to the sea base employing SAIL concepts discussed in Chapter five. The transition of command and control ashore requires a commensurate increase in communication infrastructure ashore. At that time the TDN is established, integrating

ADNS to optimize available bandwidth. OTH communication relays are made employing undersea fiber cable out to aerostat buoy systems, or by wireless transmission means.

Based on the model results, and application of the IEEE 802.11 wireless standard, the forces ashore bandwidth requirement vary within the performance of the selected system. For example, in the simulations, a single, six-user group node of independently operating units executing an OMFTS scenario demonstrated an aggregate throughput capacity of 366 KBPS at a 30 message per hour rate. Most important, by employing the SAIL concepts, it was demonstrated conceptually that communications range could be extended to support the OTH distances described in OMFTS doctrine. As demonstrated in further scenarios, message throughputs increased with the additional users on the network. The point of saturation, beyond available bandwidth was operating with four, six-user nodes in the case of NTDR.

In the event command and control is transitioned ashore, the implementation of ADNS within the shore based tactical data network would by design, provide a four-fold increase in bandwidth utilization. Coupled with the SAIL concepts, communications for the TDN can be extended significantly to ranges of up to 200 miles, based on the number of relays, and buoys, and aerostats deployed in the region.

## **B. AREAS FOR FUTURE RESEARCH**

The LRAN solutions introduced and discussed in this thesis are expected to be tested extensively in upcoming War Fighting Lab, Urban Warrior experiments. As currently planned, NFESC and NRAD are expected to implement wireless digital radios with the seabased aerostat, buoy concept to test the viability of LRAN in support of OMFTS.

Another area of research is to investigate the continued application of ADNS into the Marine Corps TDN, and demonstrate the viability of this solution. As discussed, the proliferation of bandwidth requirements far exceeds available systems in the present as well as ten years in the future. One means around this problem is to adequately manage available bandwidth such programs as ADNS.

In general, LRAN as it is presented here, focused on alternative solutions to limited satellite resources available to specifically to prosecute OMFTS in the littoral environment. The concepts required integrating wireless, terrestrial, and satellite communications demands continued attention.

Another recommendation is to investigate the type of information a user requires, and when. This includes types of services such as voice, video, and data, and at what period or interval. This might involve investigating a concept where classes of users are designated based on the type of products they require, transmitted from sea based

base units to smaller type units, down to the platoon size or squad size force. An infantry squad certainly wouldn't require video capability as would a battalion commander is one obvious example. From this, decisions can be addressed on the types, and capacity of technology matched to the class user needs.

The ideas discussed here should be further extended and applied in the area of supporting Maritime Prepositioned Ship (MPS) operations, or in joint operations requiring joint logistics over the shore (JLOTS) operations where ports of entry are not accessible or available for the introduction of forces in sustained land campaigns.

### **C. CONCLUSION**

Because it is uncertain where the Marine Corps will fight future battles, MAGTF expeditionary capabilities are highly dependent on their timely arrival in the objective area. Command and control during future deployments must be employed with increased speed and flexibility. An operation in the Littoral itself is about implementing warfighting precepts of OMFTS and fighting in a joint environment. An operation in the Littorals has four interwoven components: Approaching the littoral - where we can deter or strike the enemy, but he has difficulty reaching us; in the littoral - where we can mutually engage; on the littoral - we put

troops ashore and support their operations; leaving the littoral - after mission accomplishment.

Although there is some sequence to these components, they are not distinct or independent. A network centric approach is essential to support the dynamic operational environment within the littoral regions, and to support the coupling of existing and emergent technology to evolving littoral doctrine.



## **APPENDIX A MARITIME STRATEGY**

The purpose of the following discussion is to provide additional background with regard to maritime issues that effect the ongoing debate over a changed maritime strategy that eventually led to doctrinal concepts such as "From..The Sea", and OMFTS.

### **1. Littoral Geography**

The oceans throughout the world, particular near-shore areas, have been used more intensively as result of world population growth and technology improvements. As Figure A.1 portrays, 80 percent of the world's capitals lie within three hundred miles of the sea. 75 percent of the world's population lives within two hundred miles of the sea, and 99 percent of U.S. exports travel on the seas, with many of the important chokepoints controlled by states in crisis. [Ref. 39] Similarly, the majority of naval battles are fought near shore, and most land battles in this context are near coastal regions, and accessible by naval forces.

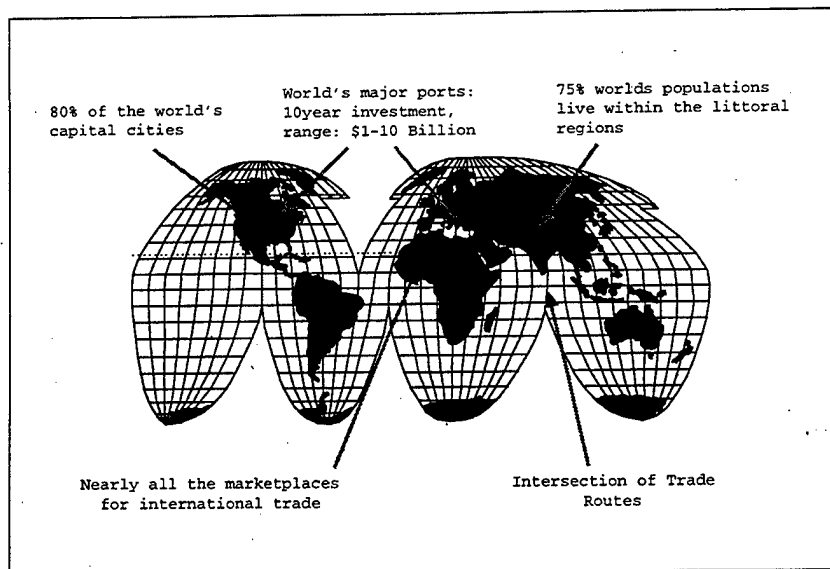

Figure A.1. Geography of the Littoral Regions.

## 2. The Law of The Sea

The 1992 UN Law of The Sea convention significantly increased the importance of nations situated along coastal regions throughout the world. Each coastal nation gained increased authority in its territorial seas (out to 12 nautical miles) and jurisdiction in its exclusive economic zones (out to 200 miles) and continental shelf. Coastal regions are important in strategic economic and political terms. These nations determined the allowable catch of resources in their economic zones and were granted exclusive rights for exploring and exploiting resources on their own continental shelf. Furthermore, as much as 30 percent of the



world's natural energy resources are extracted from off shore areas. This figure will is expected to increase as the world's energy demands continue to rise. [Ref. 10]

### **3. Maritime Disorder**

According to the International Maritime Bureau, there has been a 10 percent increase in acts of piracy in the last four years. This is particularly true in the Malacca and Singapore straits and the East China Sea. [Ref. 39] Other near-land issues also threaten the maintenance of order at sea. For example, U.S. national and political security is threatened by illegal arms running and forced migrations. Just in the last ten years, regional conflicts, civil wars and poor economic conditions, as well as drug smuggling are most pronounced in the Adriatic, and Caribbean Seas.

### **4. Near-Land Employment of Naval Forces**

The impact of this was the subsequent changed naval maritime strategy toward the world's littoral regions rather than the open seas. The littoral environment and the potential enemy, which may be encountered, imposed new demands on U.S. naval forces. For example, a study performed by the Center for Naval Analysis concluded that since World War II there were 325 instances where U.S. military forces responded to crises. 83 percent included naval forces, and about half of the responses were entirely naval in composition. The conclusion was that naval forces would certainly be called upon to counter various threats. They

can and will influence events not only at sea, but also on land. [Ref. 40]

Through extensive historical analysis, Frank Uhlig, editor emeritus of the Naval War College Review, conducted an exhaustive study of the actual employment of naval forces in his book, *How Navies Fight: The U.S. navy and Its Allies*. He concluded that the most common employment of naval forces was the support of operations ashore, the landing of forces, and the protection of shipping at sea. [Ref. 41] These findings help substantiate focus toward a maritime strategy that supports combating the littoral threat across a full range of capabilities.

## APPENDIX B NETWORK TERMINOLOGY

The following discussion is provided as background information toward a thorough understanding of network terminology associated with network centric design of the LAN concept.

### 1. Local, Metropolitan, and Wide Area Networks

Conceptually in scale, a network is defined as a Local Area Network (LAN), a Metropolitan Area Network (MAN), or a Wide Area Network (WAN). User groups from the same organization or within the same facility define a LAN as a network of digital systems that share a communication medium used for local communications. A single LAN cannot handle an arbitrary number of digital communication systems nor can a LAN connect communication systems at an arbitrary number of sites. Consequently, techniques exist to extend distances to wider areas. For example, a MAN has higher speeds than a LAN or a WAN and connects users separated by tens of miles, and advantages technologies supporting high data transfer rates. A WAN spans a large geographical area for hundreds of miles connecting hundreds of users operating on separate heterogeneous networks. It is classified as either a terrestrial or wireless network, and operates at speeds of a few mega bits per second or less. [Ref. 24]

Design decisions for a MAN or a WAN are based on the amount of traffic passed between LANs. These decisions

include type of connecting communication mediums and type of technology to employ. In traditional industry parlance a WAN system is characterized by technology that supports user rates that are less than 100 MBPS, delays on the order of 100 ms between users. The number of users can exceed the hundreds. What is essential is that the WAN support voice, video, and data services at a reliable rate of throughput with acceptable delays. [Ref. 24] In general, a wireless system is an excellent choice for mobile forces, whereas a terrestrial system applies to stationary forces that rarely relocate.

## **2. Network Standards**

The specific use of standards and guidance varies upon the function of the network, and are established based on commercial and government research, design and testing.

### **a. Standards Organizations**

The standards organizations include the United States Standards Bodies, such as the American National Standards Institute (ANSI) and the National Institute for Standards and Technology (NIST). The major standards bodies for information technology are the International Standards Bodies to include the International Telecommunications Union-Telecommunications Standardization Sector (ITU-T); the Internet Engineering Task Force (IETF), and most important in terms of networking is the Institute of Electrical and

Electronics Engineers (IEEE). Finally, there are Industry Consortia, which consists of end users, software suppliers and manufacturers. Examples include the Open Software Group (TOG), and the Network Management Group (NMG).

**b. Benefit of Standards Organizations**

To the advantage of the consumer, the wealth, expertise and knowledge of these bodies provide the framework for the future of the Navy and Marine Corps computing and communication needs. They provide significant business value by providing ready-made technology for network connectivity leading to rapid sharing of information, dynamic application employment, and leveraged network operations. Adoption of open standards negates the days of platform, single function, stovepipe systems, and introduces, or extends the traditional client/server model to a network centric computing environment.

**c. U.S. Navy Standards and Guidance**

Standards and guidance established by the previous mentioned organizations and later adopted by the majority of commercial industry are used extensively in development of DOD Standards such as the Joint Technical Architecture (JTA), the Technical Framework for Information Management (TAFIM). Recently the Department of the Navy promulgated standards and guidance in the Information Technology Standards Guidance, (ITSG) document as well as the Navy

Virtual Internet (NVI). [Ref. 42] Both are intended to complement the JTA as well as the TAFIM. These documents represent a compilation of commercial, federal, and military standards and specifications.

In addition, the ITSG applies an accepted variation to the traditional and seven layer, Open

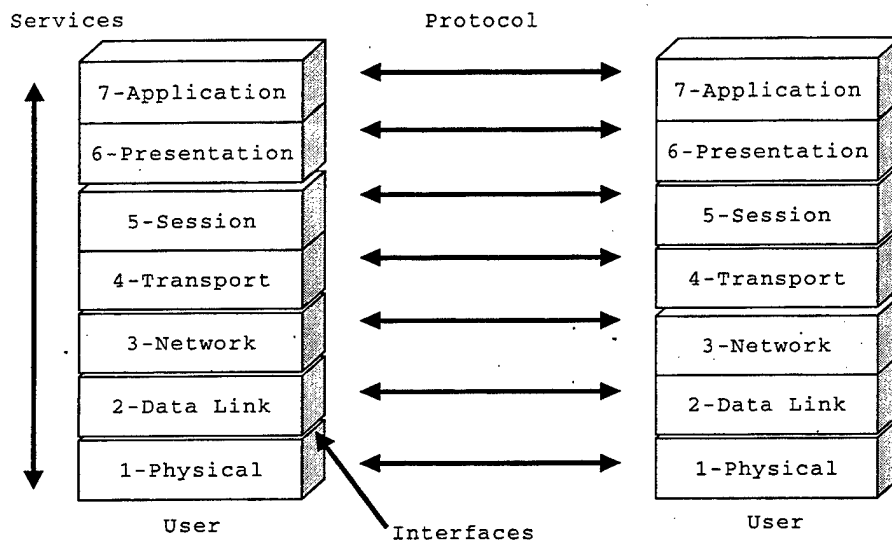

Figure B.1. The OSI stack system.

Interconnection (OSI) Reference model portrayed in Figure B.1, throughout document organization and presentation to facilitate understanding the technology choices and their relation to accepted practices in network architecture and design. Within the context of the OSI model, an open system is one that supports this model for connecting systems and networks.

#### **d. Protocols**

Protocols are a set of rules governing the format and meaning of messages (frames and packets) exchanged by peer systems within each of the respective layers. Between each layer, operations are performed by services. If a service is thought of in terms of an operation between two layers, then this represents an interface, or the interoperable nature of a system, and its peers, regardless of implementation. A packet is a self-contained parcel of data set across a computer network. Each packet contains a header that identifies the sender and recipient, and data to be delivered. The term frame is used to denote the definition of packets for a given hardware technology. [Ref. 7]

#### **e. OSI Model**

The OSI model is used to conceptually describe how to connect any combination of devices for the purpose of communication. The seven layers form a hierarchy from the application at the top to the physical communications medium at the bottom. Functions and capabilities are referenced in each layer of the model, later leading to accepted standards and practices. The model does not prescribe how this functionality must be implemented to support a specific requirement. This is left to the network design architect. [Ref. 8]

**f. Department of The Navy Information Technology Standards Guidance**

The Navy ITSG facilitates network design through prescribing sets of accepted standards and guidance employed throughout commercial industry. Later chapters of this thesis will periodically refer to the ITSG for selection, discussion, and comparisons of acceptable technologies for LRAN design.

**3. Common Interfaces**

There are numerous ways to interconnect the end systems of a network. As previously mentioned, interfaces are required to physically connect end systems to the network. Protocols are required to provide integrated services and to manage components. Common interfaces are required to ensure compatibility between end systems so that data can properly sent and received over the network. Examples of interfaces are gateways or routers between subnets of the network backbone to a WAN. Figure B.2 offers a simplistic view of this concept.

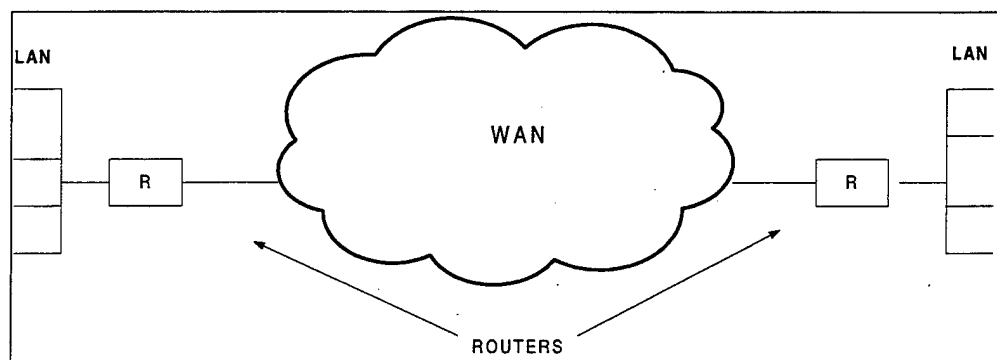

Figure B.2. Basic Components of A Wide Area Network.



The router is a special purpose computer that is dedicated to the task of managing the information transfer generated by each of the respective LANs. The router is the basic building block of WAN technology. Interconnecting a set of routers and then connecting them to one another forms a WAN. Additional routers or interconnections can be added as needed to increase the capacity of the WAN. Each router is designed and built to retain the identity of each network system it supports. Essentially, there can be multiple routers on the network. [Ref. 7]

Routers can be designed to support a SATCOM link and/or a terrestrial fiber optic cable link, thus providing multiple high bandwidth network communication paths to any user. This is represented in the figure by the "cloud."

#### **4. Network Performance**

With respect to the physical and data layer of the OSI model, data types and data flow of Voice, Video, and Data are characterized by applications such as e-mail, file transfer protocol (FTP), imagery data, video teleconferencing, and interactive applications such as those on an the internet or intranet.

Network performance from one source, or node to a receiving source, or node is gauged by the amount of delay to transmit information using one of the above applications. The delay in the network is emulated by the time it takes a

packet to travel the network model of devices, links, and nodes used to characterize the network.

### 5. Network Delay

The delay packets experience through a network is a function of the elements that constitute the network, the traffic that goes through these elements and the way the network is operated. In general, total delay is equal to the required transmission time (TRANS) to send a packet, propagation time (PROP) for an electrical or optical signal, queuing delay (QD) in a switch, and finally process time (PROC) required by the network switches. For the purposes of this study, as in most situations, processing time is considered negligible. [Ref. 17] In summary:

$$\text{Total delay} = \text{TRANS} + \text{PROP} + \text{QD} + \text{PROC}$$

Studies have shown there is little difference in delay for data rates above 10 MBPS using circuit switched connections or a packet switched service. Subsequently, the majority of delays are the result of servers waiting to perform requested functions (not really a network as perceived, but rather a device problem), and packet queuing delays in routers. [Ref. 24]

However, this isn't necessarily true for tactical networks. Delay is detrimental with respect to criticality of traffic, such as threat imagery delivered to an awaiting unit commander for time sensitive, mission critical fire support. Another example is a change in mission priorities

delivered FTP over a wireless data network. For this reason, traffic priorities are assigned based on network requirements.

#### **6. Data Flows and Applications**

The application layer must have a clearly defined transport interface. Examples include voice, video, and data such as File Transfer Protocol (FTP), e-mail, messaging or video teleconferencing (VTC).



## APPENDIX C EXTEND MODELS

The following figures represent the single six-user node Extend models developed to investigate of initial LRAN architectural considerations. The Decomposition diagram in Figure C.1 and the list of accompanying figure labels in each block is matched to the figures listed in this section for the different hierarchical layers of the 802.11 Extend model. Figure C.2 is the first layer of the Extend model. It represents the hierarchical, user group message generation blocks, their connection to the network, and the network output to the SAIL relay point, and onward to the sea base. Figure C.3 represents one layer below the "user" message generator block. Messages generated at a random size between parameters set within the model. The messages are then split into their respective packets based on the packet size of the NTDR system, which in this case is 18,768 bits. Like many of the parameters in this model, This value can be changed based on the type of wireless system. Packets are then sent over the network. Figures C.4 through C.6 represents the network for a six-user node network. CSMA is implemented through a series of logic blocks that manage network flow. As transmission delay, and collisions occur, packets are resent back through the network, or travel through unobstructed. Figure C.7 represents switching and bandwidth delay incurred at the SAIL relay point. Total

network delay is determined from the time when a user group generates a message to reception and processing at the sea base. For purposes of the model, statistical plots, and averages are determined at the sea base to determine throughput rates for the various network simulations.

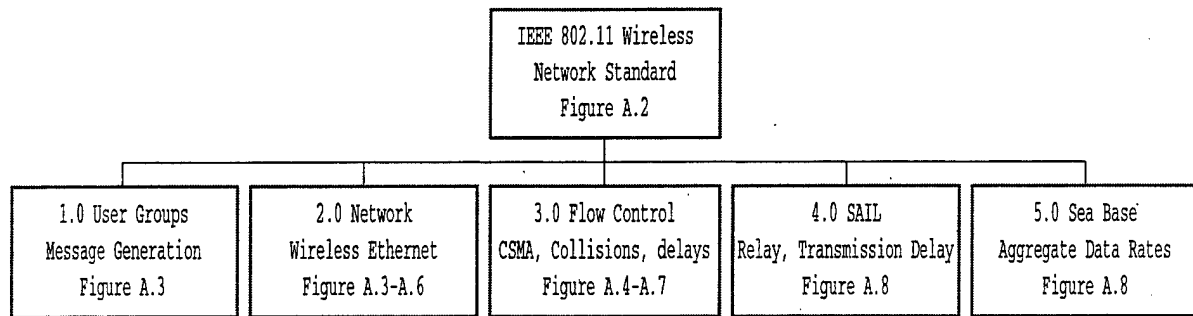

Figure C.1. Decomposition Diagram.

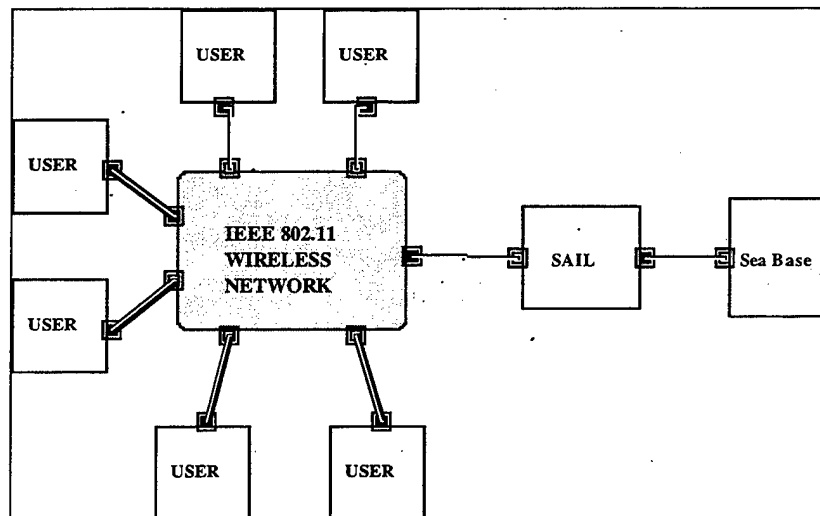

Figure C.2. Top Layer of The Extend IEEE 802.11 Model.



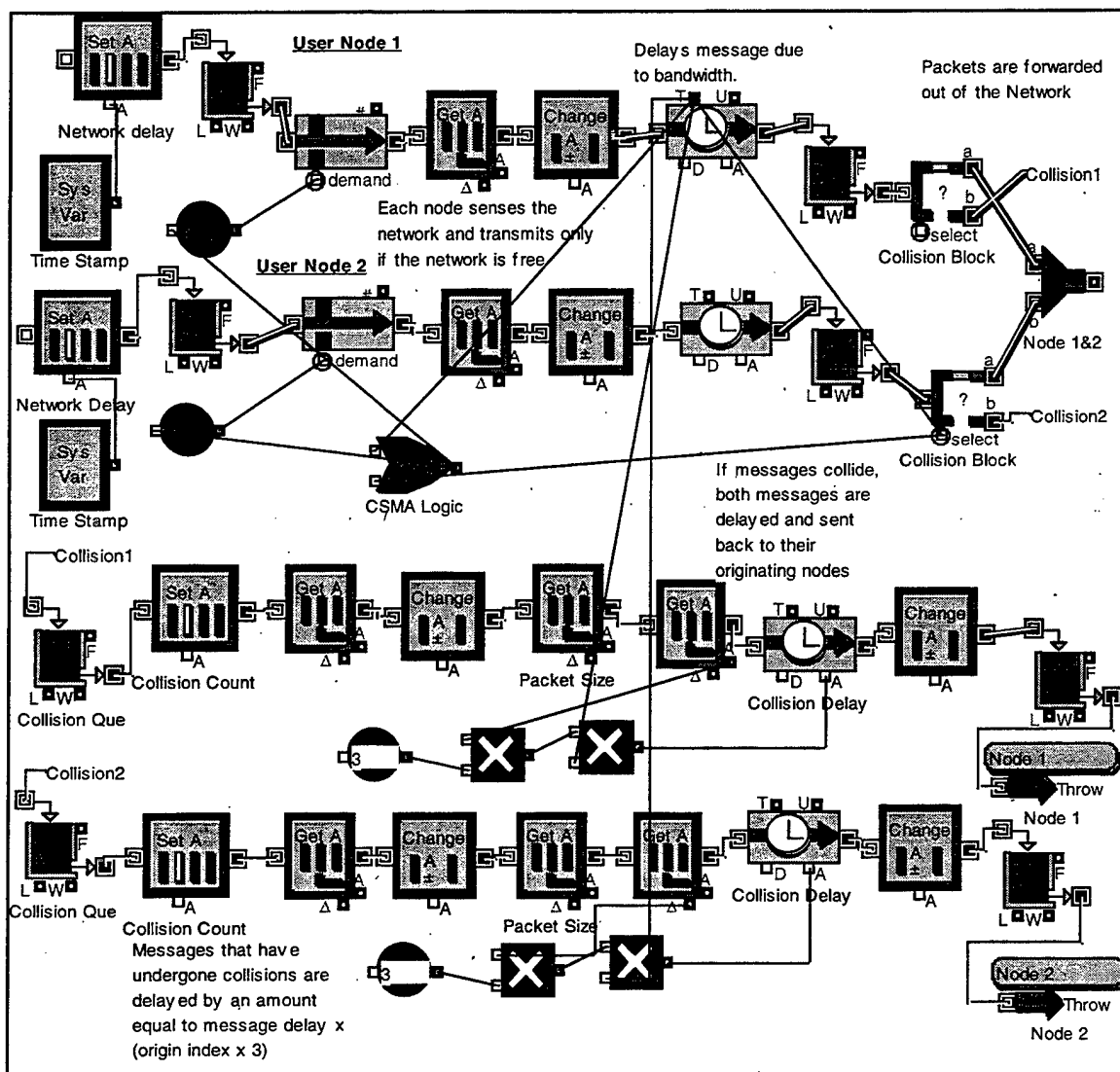

Figure C.4. Second Layer of The Extend 802.11 Wireless Network Layer, Users One and Two.



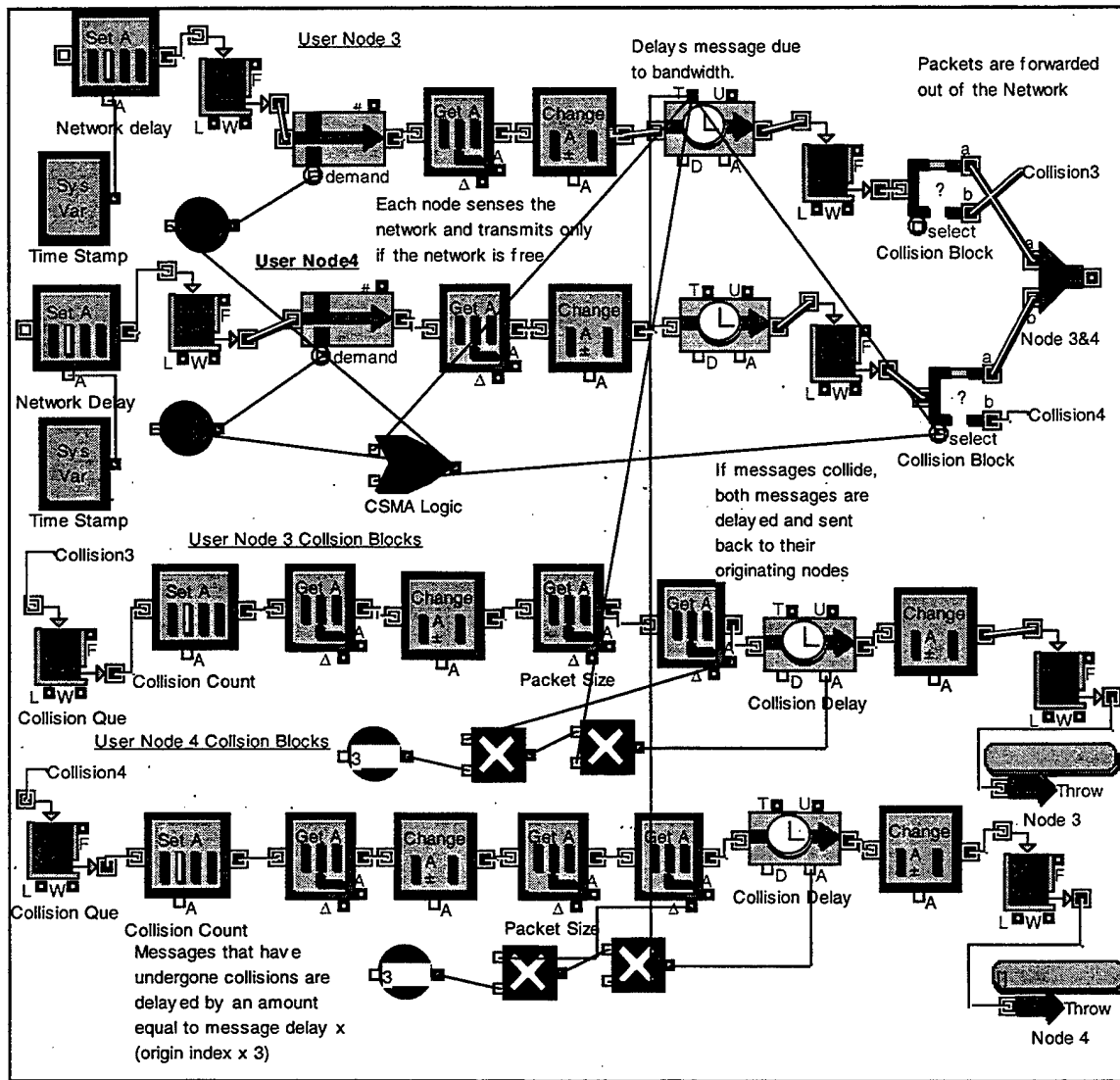

Figure C.5. Second Layer of The Extend 802.11 Wireless Network Layer, Users Three and Four.

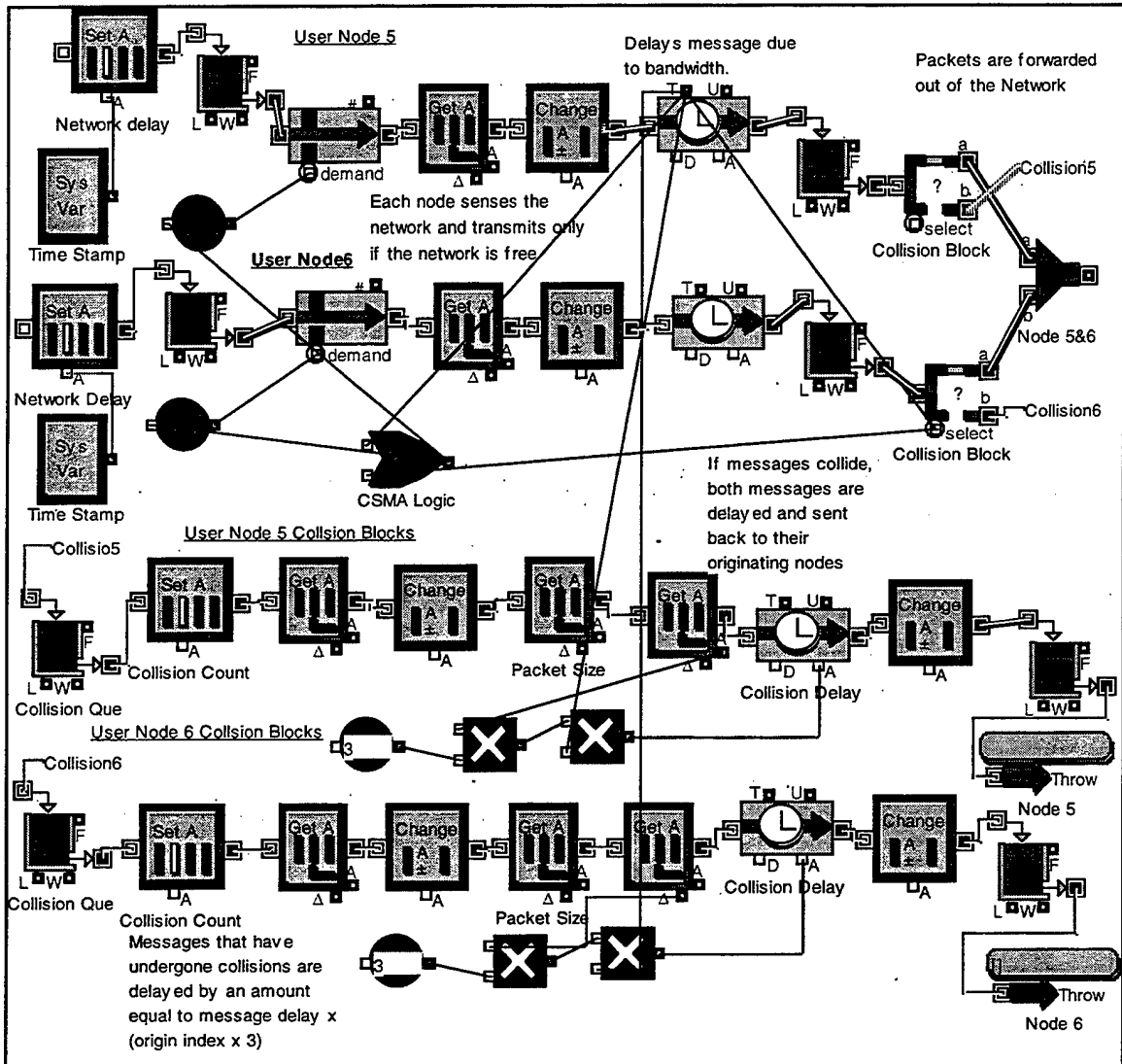

Figure C.6. Second Layer of The Extend 802.11 Wireless Network Layer, Users Five and Six

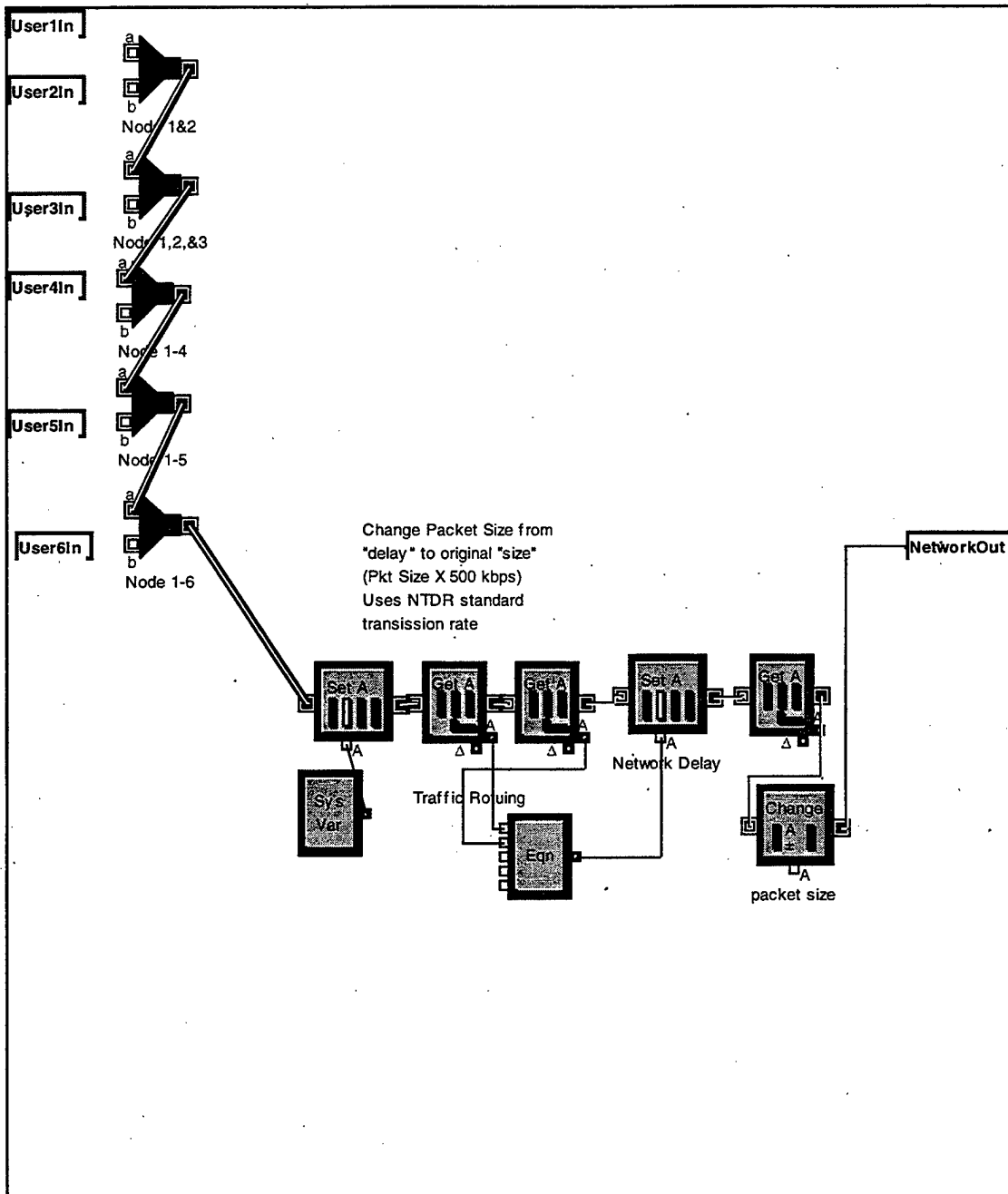

Figure C.7. Network Routing and Delay.

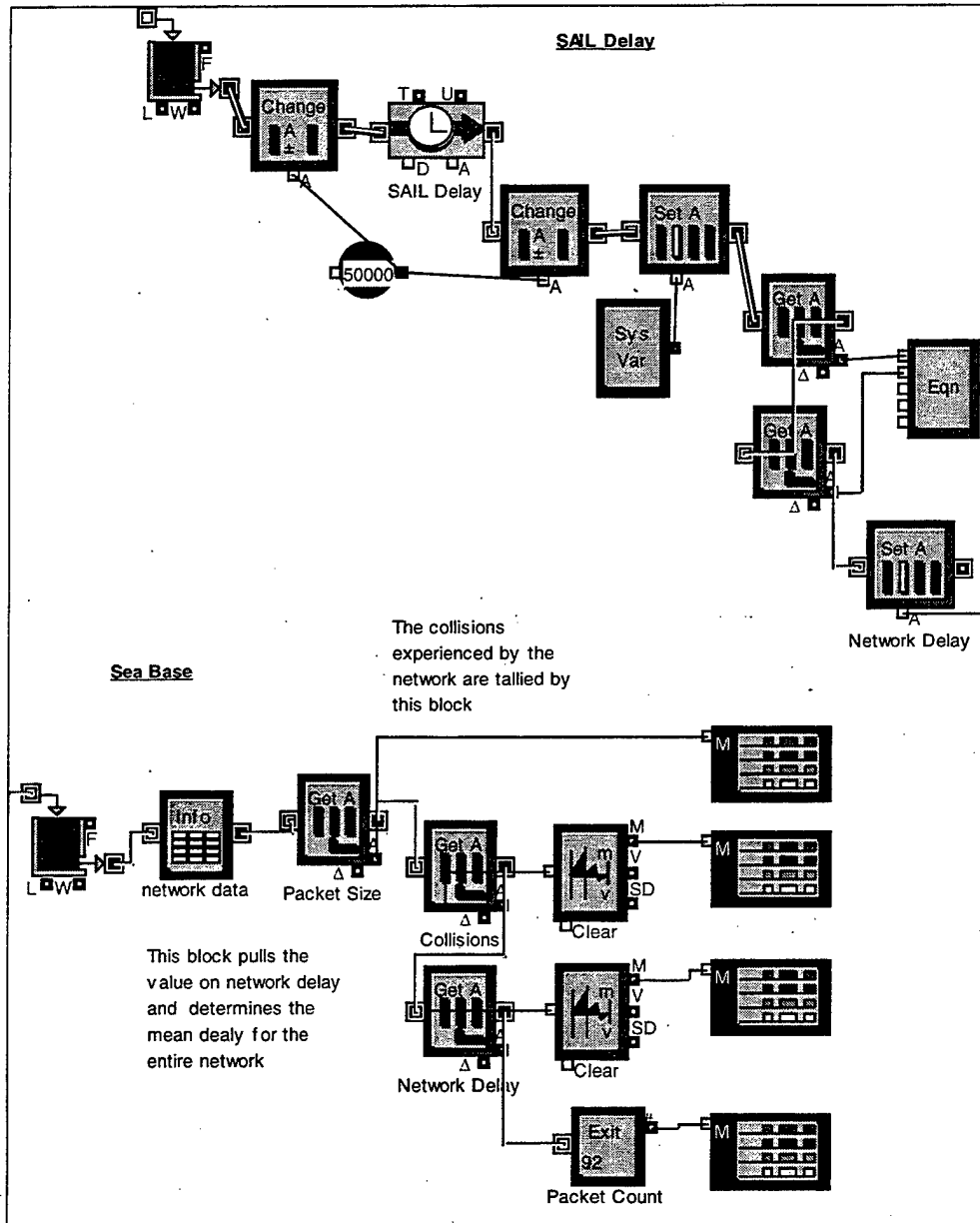

Figure C.8. SAIL and Sea Base Second Layer Blocks.

### LIST OF REFERENCES

1. U.S. Marine Corps, *Operational Maneuver From The Sea*, Marine Corps Combat Development Command, Quantico, Virginia, 1996.
2. Department of the Navy, *...From The Sea*, Washington D.C., 1992.
3. U.S. Marine Corps, *Sustained Operations Ashore*, Marine Corps Combat Development Command, Quantico, Virginia, 1997.
4. United States Navy, *Sea Based Logistics*, U.S. Naval Doctrine Command, Norfolk, Virginia, 1998.
5. U.S. Marine Corps, *Ship-to-Objective Maneuver*, Marine Corps Combat Development Command, Quantico, Virginia, 1997.
6. Comer, Douglas E., *Computer Networks and Internets*, Prentice Hall, Upper Saddle River, New Jersey, 1997.
7. Tanenbaum, Andrew S., *Computer Networks*, 3<sup>rd</sup> Edition, Prentice Hall PTR, Upper Saddle, New Jersey, 1996.
8. National Defense University, *Strategic Assessment 1995: U.S. Security Challenges in Transition*, National Defense University, Institute for National Strategic Studies, Washington, D.C., January 1995.
9. Machiavelli, Niccolo, *The Prince and The Discourses*, New York Modern Library, 1950.
10. Department of Defense, *National Security and the Convention on the Law of the Sea*, Department of Defense, Washington, D.C., July 1994.
11. Hemmler, Jeffrey, Colonel, USMC, Director, USMC, *C4ISR Remarks Regarding C2 Integration*, Naval Expeditionary C4ISR Requirements Conference, Washington, D.C., December 1997.
12. Naval Doctrine Publication (NDP) 6, *Naval Command and Control*, Naval Doctrine Command, Norfolk, Virginia, 1995.

13. Department of Defense, *C4ISR Architecture Framework Version 2.0*, Department of Defense, Washington D.C., 18 December, 1997.
14. Assistant Secretary of Defense C3I, *Department of Defense Joint Technical Architecture (JTA)*, Department of Defense, Washington, D.C., 22 August, 1996.
15. Chairman, Joint Chiefs of Staff, *Joint Vision 2010*, Department of Defense, Washington, D.C.
16. Stein, Fred P. *Observations of The Emergence of Network Centric Warfare*, Evidence Based Research, Inc., Vienna, Virginia, 20 July 1998.
17. U.S. Marine Corps, *FMFFRP 2-12 Marine Air-Ground Task Force: A Global Capability*, Marine Corps Combat Development Command, Quantico, Virginia, April 1992.
18. Defense Information Systems Agency (DISA), *DOD SATCOM Functional Requirements Document*, DISA D8, Washington, D.C., 7 February, 1996.
19. Chief Information Officer, Department of the Navy, *Information Technology Standards Guidance (ITSG)*, Department of the Navy, Washington, D.C., February 1998.
20. C4I, N85 Expeditionary Warfare Branch, Office of Naval Research, electronic mail message to the author, 14 March 1998.
21. N6, CINCPACFLT, *Presentation: U.S. Naval Institute, IT-21*, Washington, D.C., February, 1998.
22. U.S. Naval Space Command, *Naval SATCOM Emerging Requirements Database, Version 3.1*, Naval Space Command, Dahlgren, Virginia, 1 May 1997.
23. Marine Corps Systems Command (MARCORSYSCOM), *Tactical Data Network System Description*, Quantico, Virginia, September, 1995.
24. Warland, Jean and Varaiya, Pravin, *High Performance Communication Networks*, Morgan Kaufmann Publishers, San Francisco, CA, 1996.

25. Office of Naval Research, *Task No. AL-11 Navy Sea Base Logistics: Communications Link*, Washington, D.C., April 1997.
26. Bartel, Warren A., Kelly, Shawn W., Smith, Bryan J., Warren, David R., Wilson, Jeff V., *Conceptual Study of The Seabase aerostat Information Link*, U.S. Naval Facilities Engineering Service Center, Port Hueneme, California, July 1998.
27. North, Richard, *Mobile Network Radios for USMC, Proposal to USMC AWT for FY 1999*, U.S. Naval Space Warfare System Center, San Diego, California, 1 July 1998.
28. Bryan, Dale, Lopic, Stephan, North, Richard and Staley, Tom, *Wireless Networked Radios for USMC and USN LOS Applications*, U.S. Naval Space Warfare System Center, San Diego, California, 22 June 1998.
29. Rehard, Brian, *An Analysis of Quality of Service Over The Automated Digital Network System*, U.S. Naval Postgraduate School, Monterey, California, September, 1996.
30. Buddenberg, Rex, *Lecture Notes on ADNS, Advance Concepts in Telecommunications and Networking*, Fall Quarter, 1997, Naval Postgraduate School, Monterey, California, 1997.
31. Buddenberg, Rex, Electronic Mail Message to NFESC, and the author, 15 February
32. 1998.Imagine That! Incorporated, *Extend Users Manual*, San Jose, California, 1997.
33. Desrichers, George R., Fortier, Paul J., *Modeling and Analysis of Local Area Networks*, Multisicence Press, Boca Raton, Florida, 1990.
34. Schiomaker, S., *Computer Networks and Simulation III*, Elsevier Science Publishers, Amsterdam, The Netherlands, 1986.
35. Davis, Scott A., *Modeling A Joint Combat Identification Network*, U.S. Naval Postgraduate School, Monterey, California, December, 1997.
36. Rieffer, Alan R., *Analyzing Communication Architecture Using Commercial Of-The-Shelf (COTS) Modeling and*

*Simulation Tools*, U.S. Naval Postgraduate School, Monterey, California, June 1998.

37. U.S. Marine Corps Warfighting Lab, *After Action Report from Exercise Hunter Warrior*, Quantico, Virginia, 1997.
38. Misiewicz, Mike, *Modeling The Global Broadcast System (GBS) Reachback Capability*, U.S. Naval Postgraduate School, Monterey, California, September 1998.
39. Till, Geoffrey, *Trouble in Paradise: Maritime Risks and Threats in The Western Pacific*, Jane's Intelligence Review, 1995.
40. Smith, Edward A., Jr., Captain U.S. Navy, *What "...From The Sea Didn't Say*, Naval College Review, Naval War College Press, Newport, Rhode Island, Winter, 1995.
41. Uhlig, Frank, Jr. *How Navies Fight: The U.S. Navy and Its Allies*, U.S. Naval Institute, Annapolis, Maryland, 1994.
42. Chief Information Officer, Department of the Navy, *Information Technology Standards Guidance (ITSG)*, Department of the Navy, Washington, D.C., February, 1998.



**INITIAL DISTRIBUTION**

1. Defense Technical Information Center ..... 2  
8725 John J. Kingman Road, Ste 0944  
Fort Belvoir, VA 22060-6218
2. Dudley Knox Library ..... 2  
Naval Postgraduate School  
411 Dyer Road  
Monterey, CA 93943-5101
3. Rex Buddenberg Code SM ..... 1  
Systems Management Department  
Naval Postgraduate School  
Monterey, CA 93943-5000
4. Professor John Osmundson, Code CC/OS ..... 1  
555 Dyer Road, Room 304  
Naval Postgraduate School  
Monterey, CA 93943-5103
5. Director, Training and Education ..... 1  
MCCDC, Code C46  
1019 Elliot Road  
Quantico, VA 22134-5027
6. Director, Marine Corps Research Center ..... 2  
MCCDC, Code C40RC  
2040 Broadway Street  
Quantico, VA 22134-5107
7. Director, Studies and Analysis Division ..... 1  
MCCDC, Code C45  
3300 Russell Road  
Quantico, VA 22134-5130
8. Marine Corps Representative ..... 1  
Naval Postgraduate School  
Code 037, Bldg. 234, HA-220  
699 Dyer Road  
Monterey, CA 93940
9. Marine Corps Tactical Systems Support Activity ..... 1  
Technical Advisory Branch  
Attn: Maj J.C. Cummiskey  
Box 555171  
Camp Pendleton, CA 92055-5080

- 10. NFESC..... 1  
ESC 31  
Attn: Dace Warren  
1100 23<sup>rd</sup> Ave  
Port Hueneme, CA 93043
  
- 11. Marine Corps Warfighting Lab..... 1  
Attn: LtCol Carl Bott  
2006 Hawkins Ave,  
Quantico, VA 22134
  
- 12. NFESC..... 1  
ESC 31  
Attn: Maj Randy Lawson  
1100 23<sup>rd</sup> Ave  
Port Hueneme, CA 93043
  
- 13. Major Bryan J. Smith..... 1  
10609 E. Champagne Dr.  
Sun Lakes, AZ 85248