

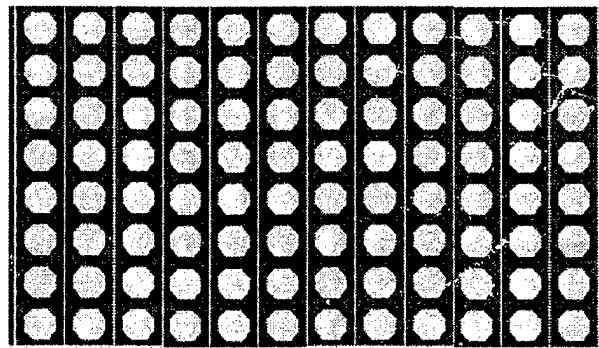

NAVAL FACILITIES ENGINEERING SERVICE CENTER  
Port Hueneme, California 93043-4370

## TECHNICAL REPORT TR-2068-SHR

### PRELIMINARY ANALYSIS OF REINFORCED CONCRETE WAFFLE WALLS



19981028 027

by

Theodore A. Shugar

March 1997

#### ABSTRACT

A preliminary analytical method based upon modified plate bending theory is offered for structural analysis of a promising new construction method for walls of small buildings and residential housing. The new load bearing elements are termed waffle walls, and they are viewed as a hybrid between reinforced concrete and reinforced masonry walls. Laboratory structural tests are recommended to verify the analytical methodology and to study further the vertical and lateral load capacity of waffle walls.

Approved for public release; distribution is unlimited.



REPORT DOCUMENTATION PAGE			Form Approved OMB No. 0704-018	
Public reporting burden for this collection of information is estimated to average 1 hour per response, including the time for reviewing instructions, searching existing data sources, gathering and maintaining the data needed, and completing and reviewing the collection of information. Send comments regarding this burden estimate or any other aspect of this collection information, including suggestions for reducing this burden, to Washington Headquarters Services, Directorate for Information and Reports, 1215 Jefferson Davis Highway, Suite 1204, Arlington, VA 22202-4302, and to the Office of Management and Budget, Paperwork Reduction Project (0704-0188), Washington, DC 20503.				
1. AGENCY USE ONLY (Leave blank)		2. REPORT DATE March 1997		3. REPORT TYPE AND DATES COVERED
4. TITLE AND SUBTITLE PRELIMINARY ANALYSIS OF REINFORCED CONCRETE WAFFLE WALLS			5. FUNDING NUMBERS	
6. AUTHOR(S) Theodore A. Shugar				
7. PERFORMING ORGANIZATION NAME(S) AND ADDRESS(ES) Commanding Officer Naval Facilities Engineering Service Center 110023rd Ave Port Hueneme, CA 93043-4370			8. PERFORMING ORGANIZATION REPORT NUMBER TR-2068-SHR	
9. SPONSORING/MONITORING AGENCY NAME(S) AND ADDRESSES			10. SPONSORING/MONITORING AGENCY REPORT NUMBER	
11. SUPPLEMENTARY NOTES				
12a. DISTRIBUTION/AVAILABILITY STATEMENT Approved for public release; distribution is unlimited			12b. DISTRIBUTION CODE	
13. ABSTRACT (Maximum 200 words) A preliminary analytical method based upon modified plate bending theory is offered for structural analysis of a promising new construction method for walls of small buildings and residential housing. The new load bearing elements are termed waffle walls, and they are viewed as a hybrid between reinforced concrete and reinforced masonry walls. Laboratory structural tests are recommended to verify the analytical methodology and to study further the vertical and lateral load capacity of waffle walls.				
14. SUBJECT TERMS Reinforced concrete, lateral load, elastic buckling, inelastic buckling, waffle wall, cement/ polystyrene			15. NUMBER OF PAGES 36	
			16. PRICE CODE	
17. SECURITY CLASSIFICATION OF REPORT Unclassified	18. SECURITY CLASSIFICATION OF THIS PAGE Unclassified	19. SECURITY CLASSIFICATION OF ABSTRACT Unclassified	20. LIMITATION OF ABSTRACT UL	

## ABSTRACT

A preliminary analytical method based upon modified plate bending theory is offered for structural analysis of a promising new construction method for walls of small buildings and residential housing. The new load bearing elements are termed waffle walls, and they are viewed as a hybrid between reinforced concrete and reinforced masonry walls. Laboratory structural tests are recommended to verify the analytical methodology and to study further the vertical and lateral load capacity of waffle walls.

## Table of Contents

	<b>Page</b>
1.0 Introduction .....	1
2.0 Analysis of Waffle Plates .....	5
2.1 Thin Plate Theory Preliminaries .....	5
2.2 Thin Plate Theory for Waffle Plates .....	7
2.3 Elastic Buckling of Waffle Plates .....	7
2.4 Estimate of Equivalent Waffle Plate Thickness .....	12
2.5 Inelastic Buckling of Waffle Plates .....	16
3.0 Proposed Structural Tests for Waffle Panels.....	21
3.1 Proposed Panel Buckling Capacity Test.....	22
3.2 Proposed Panel Shear Capacity Test.....	27
3.3 Estimated Structural Test Parameters .....	28
4.0 Summary and Conclusions .....	32
5.0 References .....	33

## 1.0 INTRODUCTION

A new building concept for single and two-story commercial and residential buildings is based on cement/polystyrene, block-like elements. When these elements are assembled into a wall, they have a network of cylindrical cavities and provide a formwork for the placement of reinforced concrete. The resulting wall or structural element is similar to conventional reinforced concrete block masonry in construction but more monolithic like reinforced concrete walls in behavior. In this sense, this construction concept may be viewed as a hybrid construction method. The assembly of cement/polystyrene building elements remains in place to serve as the insulation material for the finished building. Stucco and gypsum plaster finishes are applied to external and interior surfaces.

In a finished building, the resulting structural effect is similar to a solid wall with the difference that the wall has an open grid and waffle-like<sup>1</sup> appearance, as depicted in Figure 1-1. The surrounding cement/polystyrene formwork is not shown for clarity to reveal the load bearing component of the wall. The grid contains vertical and horizontal steel reinforcement and may also contain diagonal reinforcement. Cross-section A-A would reveal a series of cylindrical members, while cross-section B-B would reveal a solid cross-section.

The structural concept is similar to an integrally stiffened plate, which is well known to be an efficient structural use of material. In an actual stiffened plate, because the stiffeners are discrete, there is no Poisson ratio effect between them, and the well-known coupled or two-way behavior of continuous plates remains and is derived from the Poisson ratio effect of the web material between the stiffening ribs. However, in the present porous or waffle structural concept the web is entirely absent, making for lighter weight reinforced concrete construction, but the two-way behavior of a waffle plate is now largely uncoupled, making for a weaker plate as compared to a conventionally stiffened plate.

The concrete carries most of the compression edge load. However, reinforcing steel is also essential because: (1) Very few walls are truly axially loaded and therefore steel is essential for resisting any bending, and (2) If part of the load is carried by steel with its greater strength the cross-section dimensions of the wall can be reduced.

The objective of this report is to analyze the vertical and lateral load carrying capacity of waffle walls, when applied to low-rise building construction.

<sup>1</sup> The term waffle-like used here is not to be confused with the waffle-like or two-way ribbed flat-slabs often used in R/C floor and roof designs which minimize weight by removing ineffective tensile concrete during construction.

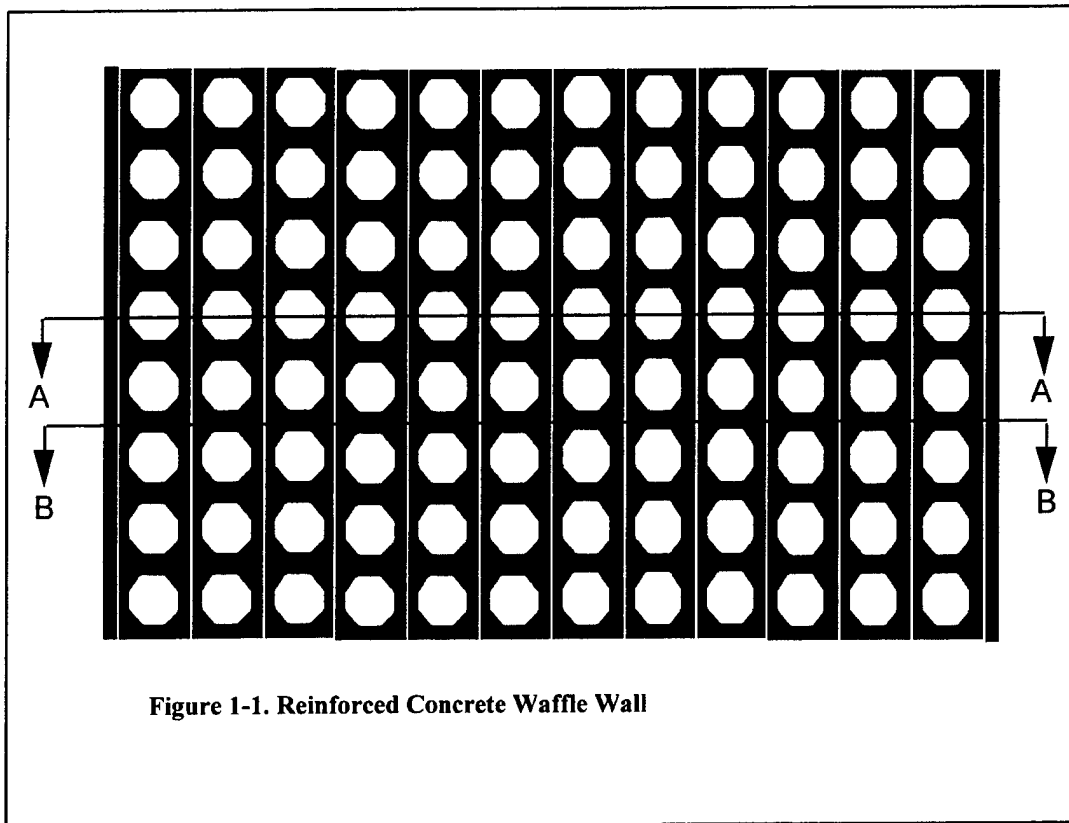

Figure 1-1. Reinforced Concrete Waffle Wall

Section 2.0 of this report contains an analysis of waffle plates treated as thin plates in which two-way behavior is uncoupled. Most of the discussion leads to derived formulas which govern elastic buckling due to continuous edge loads, and hence pertains to the vertical load bearing capacity of waffle walls. Inelastic buckling is also discussed in this section. Section 3.0 outlines two proposed types of structural tests, vertical load bearing and shear or wracking tests, for waffle walls. If carried out these tests would complement the analysis presented Section 2.0, and provide needed information on the behavior of waffle shear walls in small buildings. The potential performance of waffle walls relative to the 1994 Uniform Building Code provisions governing the design loads for shear wall resisting elements for lateral loads due to both wind and earthquake forces is discussed in a companion report (Burke and Shugar, 1997).

Design aids such as tables, charts and nomographs are nonexistent for this new construction material because it has yet to be certified by the International Conference of Building Officials (ICBO). For now, values for allowable bending, shear, and bearing stresses in structural elements have to be determined on a case by case basis. Pesce (1996) offers a design approach for small buildings with some example calculations. This procedure does not recognize plate bending wall behavior as suggested in the present analysis. Instead it follows a post and beam design approach in which waffle walls are treated as non-load bearing walls or curtain walls. It suggests that lateral load

resistance be supplied by conventional moment resisting frames. On the other hand, the view expressed in the present analysis approach is that reinforced concrete waffle walls have sufficient strength to resist lateral loads without the need for additional resisting elements such as moment resisting frames. The analytical approach proposed herein is to treat waffle walls as modified plate bending elements which include in-plane shear resistance. To resist vertical and lateral loads, these plates are assumed to be reinforced in the vertical and horizontal directions.

## 2.0 ANALYSIS OF WAFFLE PLATES

### 2.1 Thin Plate Theory Preliminaries

The transverse deflection  $w$  of a continuous thin rectangular plate made of an isotropic material is indicated in Figure 2-1.

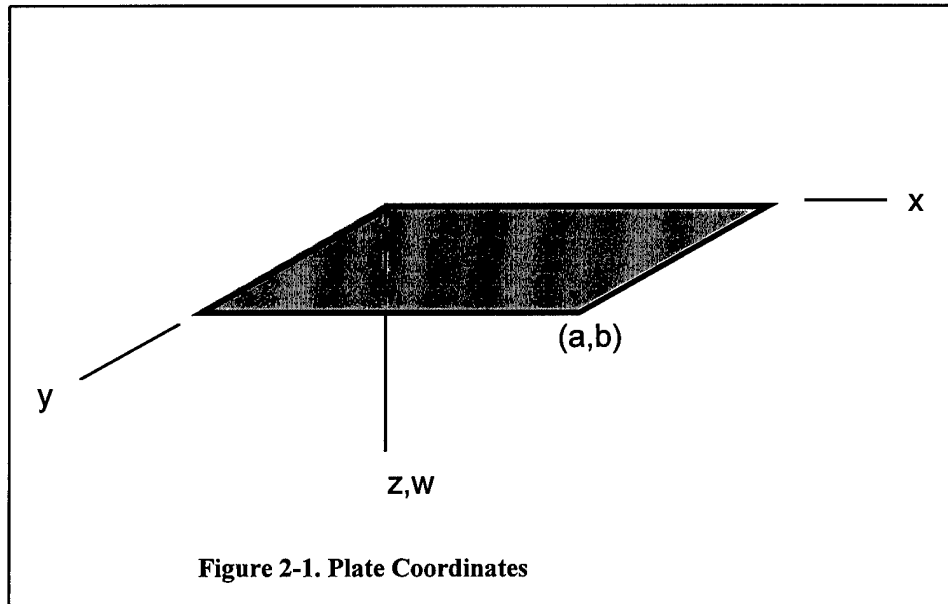

Bending moment-curvature relationships from the thin plate theory are (Jaeger, 1964):

$$M_x = -D \left( \frac{\partial^2 w}{\partial x^2} + \nu \frac{\partial^2 w}{\partial y^2} \right)$$

$$M_y = -D \left( \frac{\partial^2 w}{\partial y^2} + \nu \frac{\partial^2 w}{\partial x^2} \right)$$

$$M_{xy} = D (1 - \nu) \left( \frac{\partial^2 w}{\partial x \partial y} \right)$$

where  $\nu$  is Poisson's ratio,  $D = Et^3/(12(1-\nu^2))$ ,  $E$  is Young's modulus and  $t$  is a uniform plate thickness. Since  $I = t^3/12$  is the second moment of area per unit length,  $D$  may be interpreted as the plate stiffness or the bending rigidity ( $EI$ ) per unit length, modified by a factor  $(1-\nu^2)$  in the denominator.



To see how the term  $(1-\nu^2)$  arises consider a rectangular plate to which moments per unit length are applied along one pair of edges only, as in Figure 2-2. The curvature in the same plane as the moments is  $\phi_x = M_x/EI$ . In the plane at right angles the curvature is  $\phi_y = -\nu M_x/EI$ .

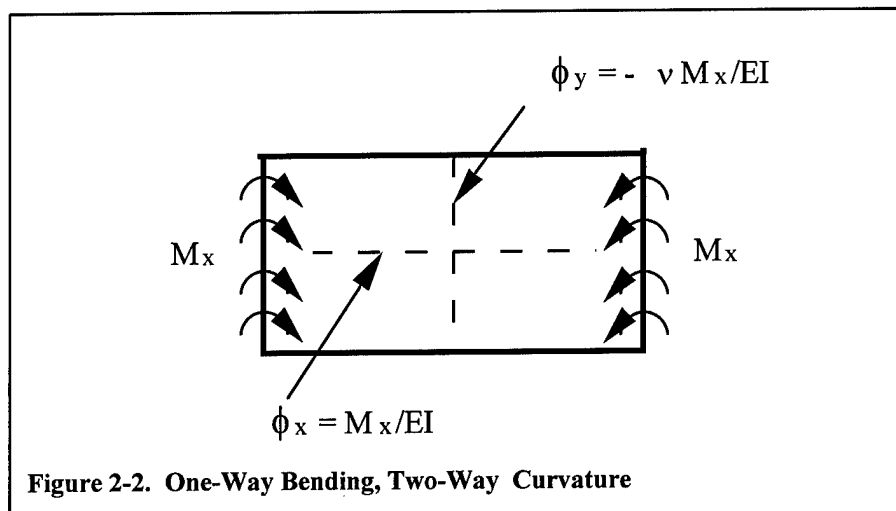

Suppose it is desired to eliminate this second curvature ( $\phi_y \leftarrow 0$ ); to do so requires a moment  $\nu M_x$  applied along the other pair of edges. This moment provides a curvature  $-\nu^2$  times the original curvature, in the original direction as shown in Figure 2-3.

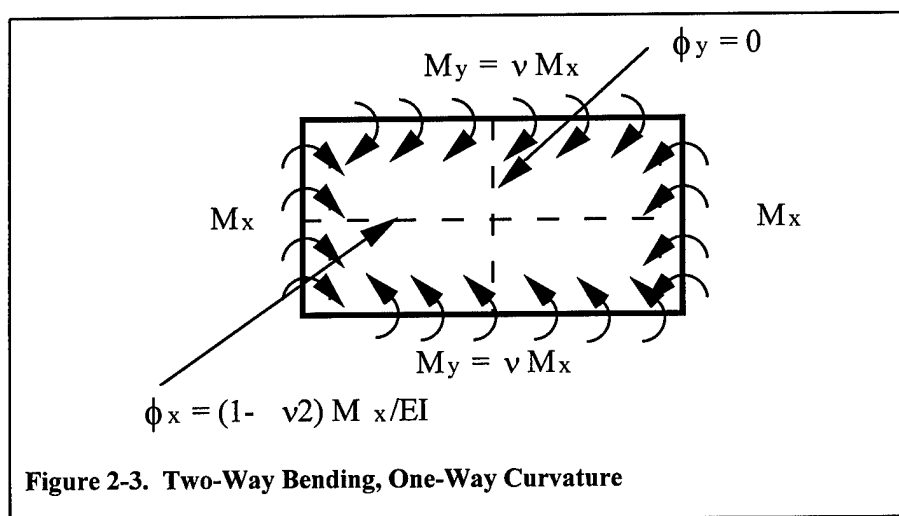

Hence, the curvature is  $\phi_x = (1-\nu^2)M_x/EI$  or  $\phi_x = M_x/D$  in the original direction.

It is concluded therefore that a moment per unit length  $M_x$  produces curvature  $\phi_x = M_x/D$  provided that the appropriate moment per unit length  $\nu M_x$  is applied in the plane at right angles so as to make the plate curvature in that plane zero.

## 2.2 Thin Plate Theory for Waffle Plates

A waffle plate is perceived to be a weak plate, in the sense that one-directional bending produces no curvature in a plane at right angles to the plane of bending as described above in conventional thin plate theory. To effect this modification, Poisson's ratio is set to zero,  $\nu = 0$ , in thin plate theory. Then, the moment-curvature relations for a waffle plate become,

$$\begin{aligned}M_x &= -D' \left( \frac{\partial^2 w}{\partial x^2} \right) \\M_y &= -D' \left( \frac{\partial^2 w}{\partial y^2} \right) \\M_{xy} &= D' \left( \frac{\partial^2 w}{\partial x \partial y} \right)\end{aligned}$$

where  $D' = Et_{eq}^3/12 = EI_{eq}$ , is the bending stiffness per unit length for waffle plates.

The equivalent plate-bending thickness  $t_{eq}$  for a waffle plate is unknown at this stage and needs to be assigned to use the theory presented in this section for specific calculations.

Now, repeating the previous thin plate theory experiment with  $\nu = 0$ , a moment  $M_x$  is applied as before, but with the result that the curvatures are  $\phi_x = M_x/EI_{eq}$ , and  $\phi_y = 0$ , as shown in Figure 2-4. This is the behavior of waffle plates as they are perceived in this study.

## 2.3 Elastic Buckling of Waffle Plates

Buckling of waffle plates is analyzed the same as buckling of conventional thin plates with the plate stiffness  $D$  replaced by  $D'$ . A waffle plate is assumed to be employed as a load-bearing wall in a building system. To investigate wall buckling, the wall is assumed simply-supported all around and loaded uniformly on its edge as shown in Figure 2.5.

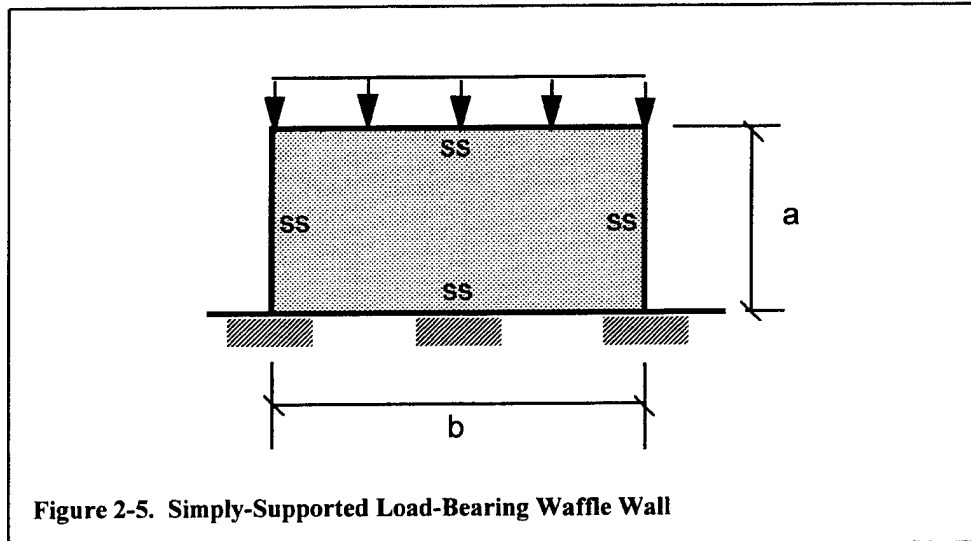
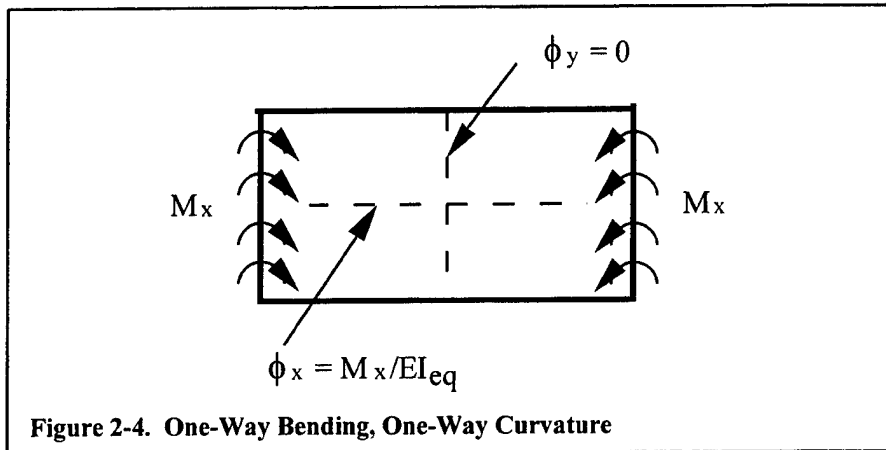

The corresponding buckling problem is posed as follows (see Timoshenko and Gere, 1961, Ch. 9)<sup>2</sup>. For the edge loaded plate shown in Figure 2-6 find the value of the edge load  $N_0$  per unit length which is just sufficient to sustain a small induced lateral deflection in the plate. This value is defined as the critical load,  $N_{0cr}$ .

The critical load of a simply-supported plate with aspect ratio  $a/b < 1$  is governed by the following equation,

<sup>2</sup> The notation and approach, particularly the use of non dimensional load  $z$ , follows Shugar, T. A. (1996). "A Course in Structural Stability," CEE 236 Draft Lecture Notes 12 and 13, University of California, Los Angeles, Spring, 1996.

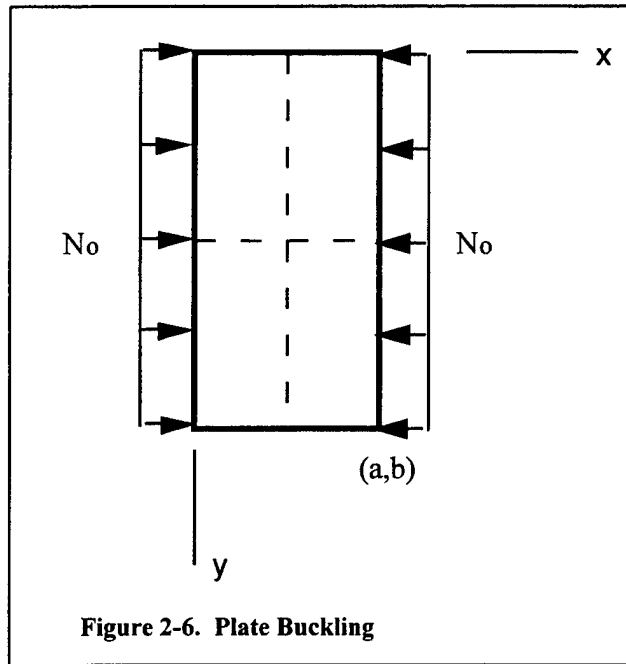

$$z = \frac{\left[ n^2 + \left( m \frac{a}{b} \right)^2 \right]^2}{n^2 + \beta \left( m \frac{a}{b} \right)^2}$$

The variable  $z$  is defined as  $z \equiv N_0/(\pi^2 D'/a^2)$ , and is interpreted as the ratio of the edge load,  $N_0$ , to the elastic buckling load,  $P_{cr} = \pi^2 D'/a^2$ , of an isolated plate strip of unit width, unit stiffness  $D'$ , length  $a$ , and simply-supported at its ends as shown in Figure 2-7. The variable  $\beta$  is the ratio of the applied edge loads in the  $y$ - and  $x$ -directions, respectively, and  $n$  and  $m$  are integers.

To obtain the critical value of the ratio  $z$ , and hence the critical value  $N_{0cr}$ ,  $z$ , is minimized over the dual space of integers  $(n,m)$ . Thus,

$$z_{cr} \equiv z_{min} = \min_{(n, m)} \left\{ \frac{\left[ n^2 + \left( m \frac{a}{b} \right)^2 \right]^2}{n^2 + \beta \left( m \frac{a}{b} \right)^2} \right\}$$

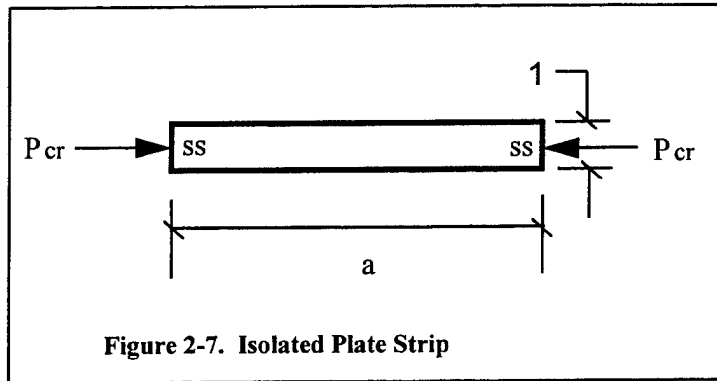

The integers  $n$  and  $m$  represent the number of half-sine waves in the buckled shape in the  $x$  and  $y$  directions, respectively. This equation immediately simplifies for  $\beta = 0$  in the case of one-way loading, which is the present case of interest (see Fig. 2-5). Therefore,

$$z_{cr} = \frac{\min}{(n, m)} \left\{ \left[ n + \frac{m^2}{n} \left( \frac{a}{b} \right)^2 \right]^2 \right\}$$

For this case, it is clear that the critical value corresponds to  $m = 1$  irrespective of  $n$  and the aspect ratio  $a/b$ . Therefore, with  $m = 1$ ,

$$z_{cr} = \frac{\min}{(n)} \left\{ \left[ n + \frac{1}{n} \left( \frac{a}{b} \right)^2 \right]^2 \right\}$$

This formula gives the critical load of a waffle plate or wall. It emphasizes that the critical load for the simply-supported plate depends also on the aspect ratio  $a/b$ . For a square plate ( $a/b = 1$ ), the minimum further corresponds to  $n = 1$ . Therefore, the critical value of  $z$  for a square plate is,

$$z_{cr} = 4$$

On the other hand, for a very long simply-supported plate the aspect ratio  $a/b \rightarrow 0$ . Therefore,  $n = 1$  is again required for the minimum and for a long, simply-supported plate (e.g., for  $a/b = 0.2$ ,  $z_{cr} = 1.08$ ),

$$z_{cr} \approx 1$$

Therefore the buckling load  $N_{0cr}$  for the waffle wall modeled as a thin elastic plate simply-supported all around, is bounded as follows,

$$\frac{\pi^2 D'}{a^2} < N_{0cr} < 4 \frac{\pi^2 D'}{a^2}$$

where  $a$  is the wall height, and  $D'$  is the bending rigidity of the wall. Further, whatever the wall aspect ratio,  $a/b \leq 1$ , the buckling mode shape is given by

$$n = 1, m = 1$$

and is as shown in Figure 2-8.

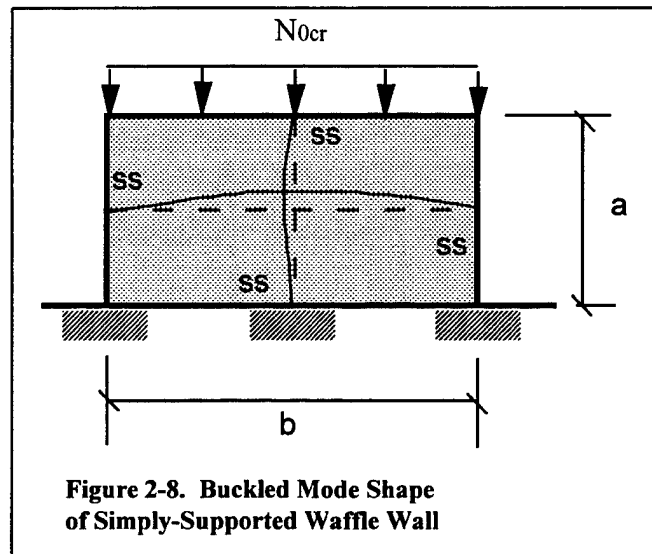

SS

The theory presented for elastic buckling of waffle walls can also be extended to other combinations of edge conditions (combinations of simply-supported, free, and fixed edges).

## 2.4 Estimate of Equivalent Waffle Plate Thickness

An approximate method for determining the equivalent bending thickness  $t_{eq}$  for reinforced concrete waffle walls is presented for use with the aforementioned elastic buckling theory which assumes a thin plate having a uniform thickness. It is based on two main assumptions:

- (1) Elastic bending stiffness  $EI_{eq}$  considers cracked section properties.
- (2) Equivalence is based on strain energy of bending.

A horizontal section through the porous load bearing part of a waffle wall (see section A-A of Figure 1-1) would appear as a series of cylindrical reinforced concrete members with uniform spacing as shown in Figure 2-9. The neutral axis of the cross-section is based on cracked section properties of the square cross-sectional area shown. An earlier approach assumed an uncracked section (Salse, 1987). The square is a convenient approximation of the circular area, and is sized to have the same moment of inertia as the circular area with respect to a diametrical axis. That is, the square area upon which cracked section properties are based has sides of length

$$S = 0.876 d$$

where  $d$  is the diameter of the circular area. The equivalent area for the steel bar is  $nA_s$  where  $n$  is the ratio of moduli of elasticity for steel and concrete, and  $A_s$  is the area of the steel bar.

The moment of inertia of the equivalent cracked section with respect to the neutral axis,  $I_{NAA}$ , is given by

$$I_{NAA} = \frac{1}{3} S \left( k_A \frac{S}{2} \right)^3 + nA_s \left( \frac{S}{2} - k_A \frac{S}{2} \right)^2$$

where  $k_A$  is given by the solution to the quadratic formula,

$$Ak_A^2 + Bk_A + C = 0$$

and

$$\begin{aligned} A &= \frac{S^3}{8} \\ B &= \frac{nA_s S}{2} \\ C &= -B \end{aligned}$$

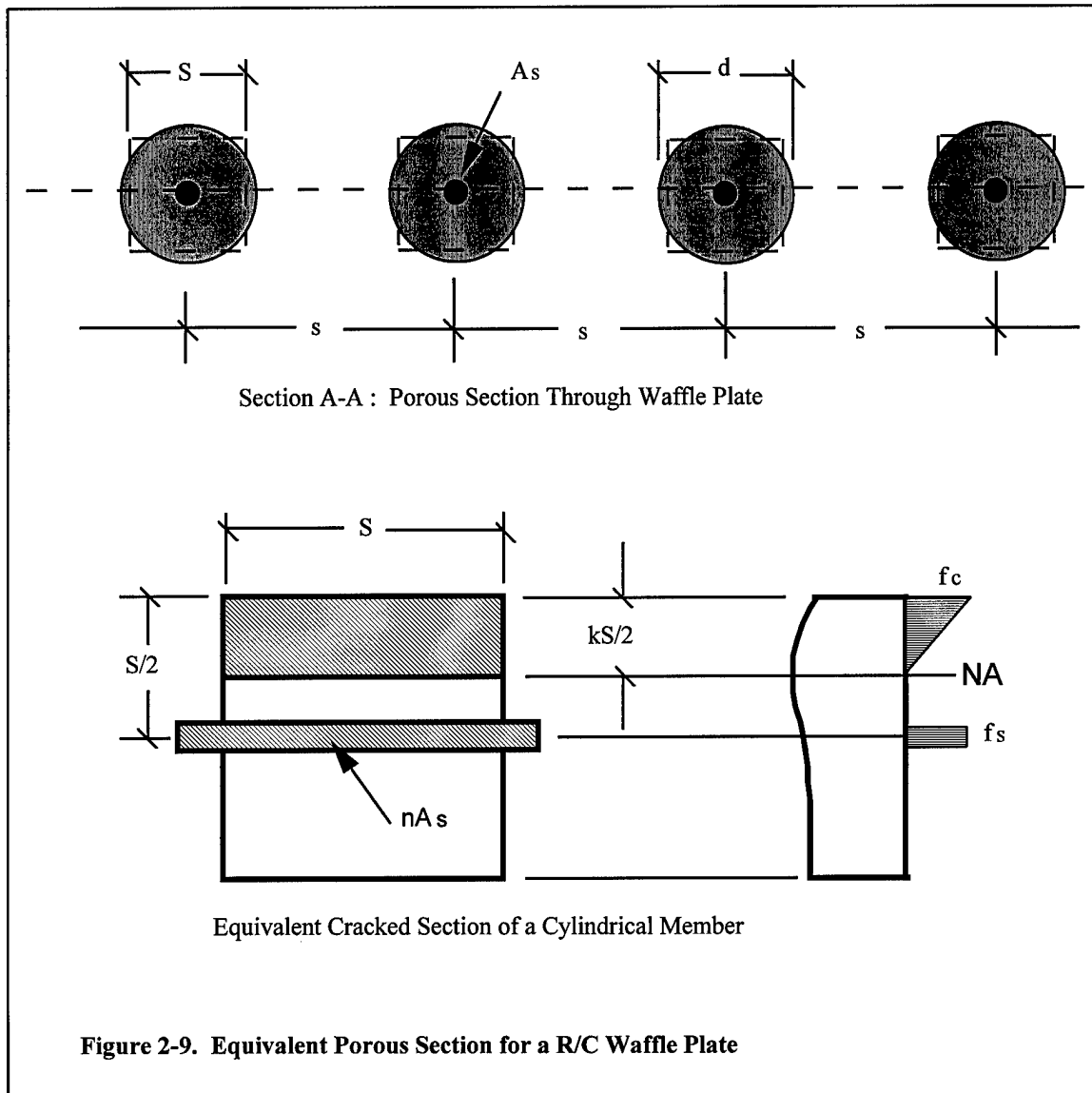

**Figure 2-9. Equivalent Porous Section for a R/C Waffle Plate**

To compensate for the discontinuous nature of a series of members with uniform spacing  $s$ , an equivalent moment of inertia per unit length is calculated as follows,

$$I_{eqA} = I_{NAA} * \frac{l}{s}$$

where  $l$  is a measure of unit length along the horizontal section (e.g.,  $l = 12$  in./ft.).

A horizontal section through the solid part of a waffle wall (section B-B in Figure 1-1) is depicted in Figure 2-10. In this case the derivation is more direct, and the equivalent moment of inertia of the cracked rectangular ( $s$  by  $d$ ) section shown,  $I_{NAB}$ , is,



$$I_{NAB} = \frac{1}{3} s \left( k_B \frac{d}{2} \right)^3 + nA_s \left( \frac{d}{2} - k_B \frac{d}{2} \right)^2$$

where  $k_B$  for the solid section is given by the solution of the previous quadratic equation with coefficients A, B, and C re-defined as follows:

$$\begin{aligned} A &= \frac{sd^2}{8} \\ B &= \frac{nA_s d}{2} \\ C &= -B \end{aligned}$$

The moment of inertia is again adjusted for unit length, so that the equivalent moment of inertia per unit length along a solid horizontal section of a waffle plate is,

$$I_{eqB} = I_{NAB} * \frac{1}{s}$$

The waffle plate has thus far been idealized as a solid member with two alternating sections having moments of inertia  $I_{eqA}$  and  $I_{eqB}$ . It can now be envisioned as a solid member with two corresponding alternating thicknesses  $t_{eqA}$  and  $t_{eqB}$ , as shown in Figure 2-11. If the profile shown is also assumed to alternate uniformly, akin to a uniform square wave, so that  $\Delta L_A = \Delta L_B = \Delta L$ , then a solid plate having a uniform equivalent bending thickness,  $t_{eq}$ , can be based on equivalent strain energy of bending,  $\Delta U$ , as follows,

$$\Delta U = \int_0^{\Delta L/2} \frac{1}{2} \frac{M^2}{EI_{eqA}} dx + \int_0^{\Delta L/2} \frac{1}{2} \frac{M^2}{EI_{eqB}} dx \equiv \int_0^{\Delta L} \frac{1}{2} \frac{M^2}{EI_{eq}} dx$$

where, as can be verified

$$I_{eq} = \frac{2 I_{eqA} I_{eqB}}{I_{eqA} + I_{eqB}}$$

This latter expression is clearly different from a simple average of moments of inertia (Salse, 1987). It assumes that bending stresses are developed throughout the "square wave" profile in the member, and this leads to a somewhat unconservative estimate from that standpoint.

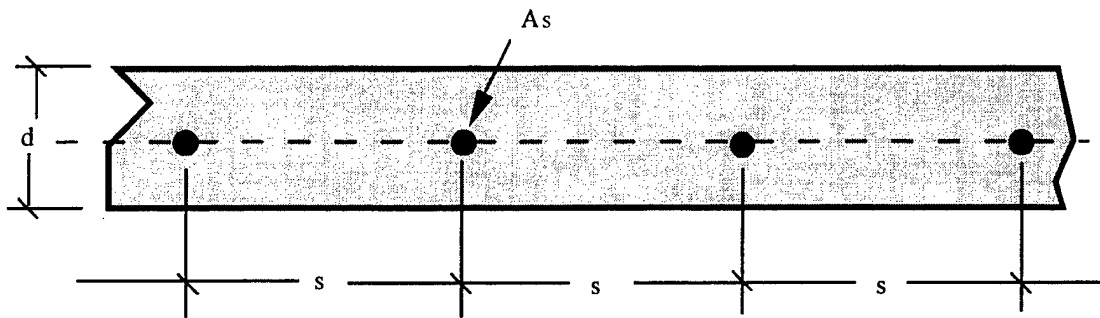

Section B-B : Solid Section Through Waffle Plate

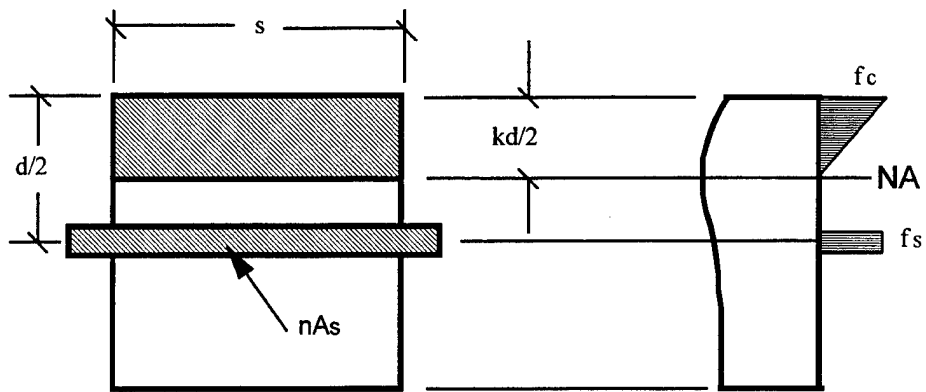

Equivalent Cracked Section of Solid Section

Figure 2-10. Equivalent Solid Section for a R/C Waffle Plate

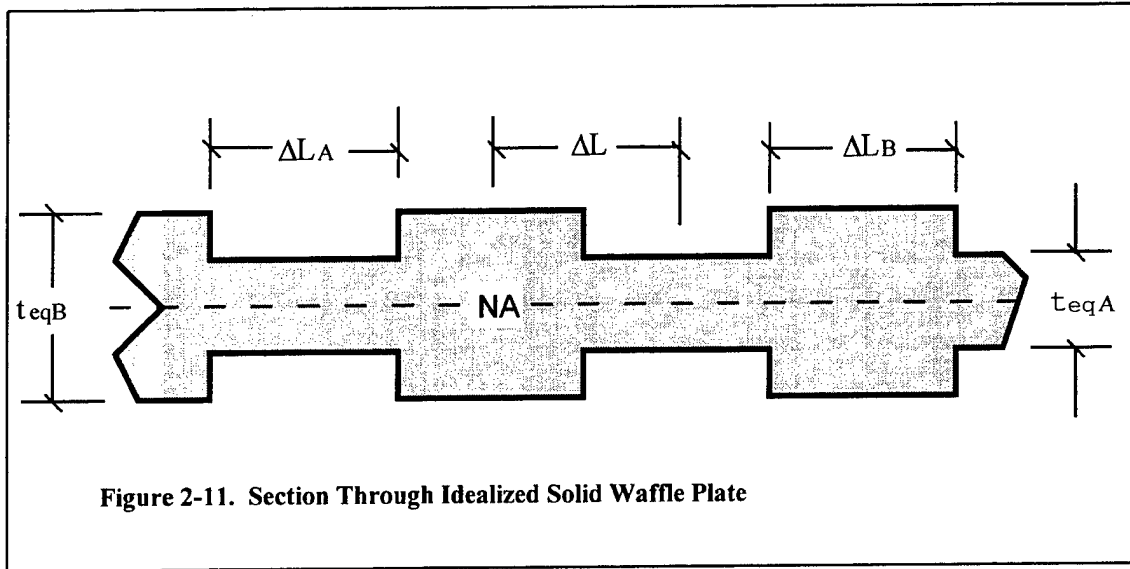

Figure 2-11. Section Through Idealized Solid Waffle Plate

$I_{eq}$  is by the above definition a moment of inertia per unit length. For example, if cross-section dimensions are in units of inches, and  $l$  is set to 12 inches/ft, then the equivalent moment of inertia of a waffle plate has units  $\text{in}^4/\text{ft}$ . Further, in the formula  $I_{eq} = (1/12) b t_{eq}^3$ , with  $b = 12$  inches/ft, the approximate equivalent bending thickness in inches for a waffle plate is ,

$$t_{eq} = \sqrt[3]{I_{eq}} = \sqrt[3]{\frac{2I_{eqA} I_{eqB}}{I_{eqA} + I_{eqB}}}$$

A more accurate estimate of  $t_{eq}$  can perhaps be made using a finite element model of the actual reinforced concrete waffle plate. Such an approach was employed to determine an equivalent bending thickness for a large built-up steel plate by Shugar, et al., (1991).

## 2.5 Inelastic Buckling of Waffle Plates

For elastic buckling into a half-sine wave mode in either direction ( $n = m = 1$ , see Figure 2-8) the critical edge load,  $N_{0cr}$ , for a simply-supported rectangular plate can be expressed as

$$N_{0cr} = \frac{\pi^2 D}{a^2} \left[ 1 + \left( \frac{a}{b} \right)^2 \right]^2$$

Alternatively, this can be expressed in terms of a critical edge stress  $\sigma_{0cr}$  (i.e.,  $N_{0cr} = \sigma_{0cr} t$ ). The equation becomes,

$$\sigma_{0cr} = \frac{\pi^2 D}{a^2 t} \left[ 1 + \left( \frac{a}{b} \right)^2 \right]^2$$

For a waffle plate, D is replaced with D', and t is replaced with  $t_{eq}$ , and thus,

$$\sigma_{0cr} = \frac{\pi^2 D'}{a^2 t_{eq}} \left[ 1 + \left( \frac{a}{b} \right)^2 \right]^2$$

For a square waffle plate ( $a/b = 1$ ) the critical buckling stress becomes,

$$\sigma_{0cr} = \frac{4\pi^2 D'}{a^2 t_{eq}} = \frac{\pi^2 E}{3} \left( \frac{t_{eq}}{a} \right)^2$$

The critical edge stress, for a given ratio  $t_{eq}/a$ , is thereby determined.

To this point in the analysis of waffle plates it has been assumed that the plate remains elastic, and that  $\sigma_{0cr}$  is less than the proportional limit for the plate material. This may not be the case for a material like concrete which exhibits inelastic behavior early in its compressive stress-strain behavior. If yielding of the plate material occurs before the critical load is obtained, the buckling load of course is smaller than the value given by the above elastic stability analysis. It is also noted that because the state of stress is biaxial, inelastic stability analysis is more complicated for plates than it is for columns.

Figure 2-12, adapted from Brush and Almroth (1975), shows a comparison of the load-deformation behavior of elastic and inelastic buckling of plates subjected to edge loads. Elastic behavior typically shows that a plate can support additional load beyond the critical value,  $N_{0cr}$ , in a nonlinear elastic post buckling range, whether the plate is perfect or whether it is imperfect (a real plate; possibly with some load eccentricity or initial curvature). In this sense  $N_{0cr}$  can be taken as a conservative estimate of the ultimate strength of the plate. Further, the ultimate failure could be more ductile as can be seen from the larger post-buckling deflection associated with elastic behavior. However, if the plate buckles below  $N_{0cr}$  due to inelastic behavior, there is no post-buckling strength as the load is immediately shed.

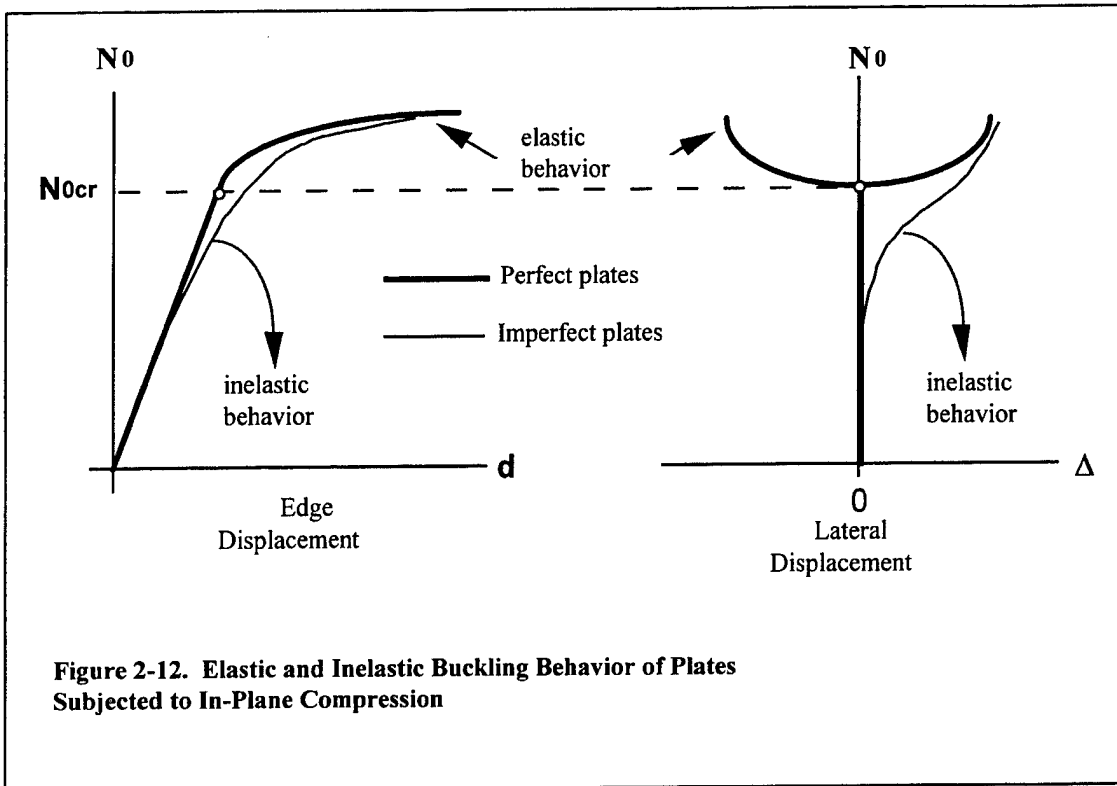

Figure 2-12. Elastic and Inelastic Buckling Behavior of Plates Subjected to In-Plane Compression

To analyze inelastic buckling of a waffle plate, the procedure given by Timoshenko and Gere (1961) for a uniform thin plate is applied. The inelastic version of the aforementioned square plate equation employs the tangent modulus for concrete,  $E_t$ , in place of  $E$ . In the absence of a stress-strain graph, specific to a material of interest, Timoshenko and Gere (1961) provide the following equation for the tangent modulus of materials having a definite, well-defined yield point,  $\sigma_{yp}$ .

$$\frac{d\sigma}{d\varepsilon} \equiv E_t = E \frac{\sigma_{yp} - \sigma}{\sigma_{yp} - c\sigma}$$

For materials without a well-defined yield point, it is recommended that the ultimate stress replace the yield stress in the above formula. For concrete in compression the ultimate stress is  $f'_c$ . The parameter  $c$  is used to identify a specific type of material; for concrete it is further recommended that parameter  $c = 0$ . Thus, the tangent modulus for concrete in compression becomes,

$$E_t = E \frac{f'_c - \sigma}{f'_c}$$

To obtain a "column-type curve" for an inelastic waffle plate it is assumed that the plate remains isotropic so that an omnidirectional tangent modulus for concrete applies. Values of critical stress below  $f'_c$  are taken and substituted into the above equation to calculate corresponding values of  $E_t$ . (This could also be accomplished with a suitable stress-strain graph for concrete in compression.) Then substituting these values into the square plate equation and solving for the ratio  $a/t_{eq}$  using,

$$\frac{a}{t_{eq}} = \pi \sqrt{\frac{E_t}{3 \sigma_{0cr}}}$$

data are obtained which is sufficient to generate the inelastic buckling curve shown in Figure 2-13. The lower curve shows the critical stress for square waffle plates which would buckle inelastically. The upper curve in this figure shows the same information for elastic buckling (where  $E$  has been used instead of  $E_t$ ), and the horizontal curve represents a crushing failure mode at the ultimate stress,  $f'_c$ . In this case,  $f'_c = 2$  ksi, and  $E = 2.57(10)^3$  ksi have been used to construct the curves shown.

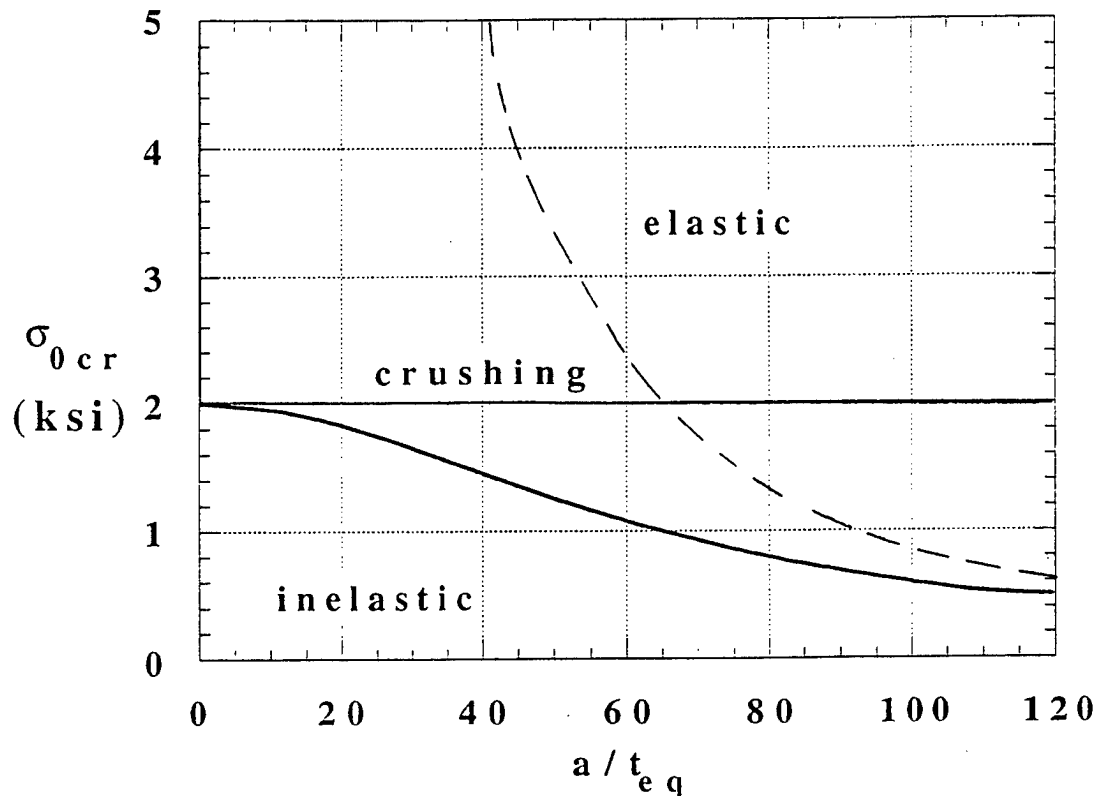

Figure 2-13. Critical Stress for Square Waffle Plates

### 3.0 PROPOSED STRUCTURAL TESTS FOR WAFFLE PLATES

The preceding analysis of waffle plates requires experimental verification and experimental data for understanding how load bearing walls and shear walls behave. Specifically,

- (1) The equation for equivalent out-of-plane bending thickness  $t_{eq}$  derived for a waffle plate needs to be verified, so that the corresponding derived equations may yield the buckling capacity of load bearing walls in a building, and so that walls may be designed to resist out-of-plane loads. Further, experimental data are needed to establish whether buckling behavior is elastic or inelastic.
- (2) Measurement of the in-plane shear resistance of a waffle plate in wracking is required because it is crucial to designing shear walls to resist lateral loads on buildings due to wind and earthquake loads. Moreover, the ductility of waffle shear walls under cyclic wracking loads is also required for earthquake design.

Two types of structural laboratory tests are proposed to address the above concerns. The first test addresses both the equivalent bending stiffness and the buckling capacity of waffle plates. The second test addresses the static shear wracking stiffness and load resistance of waffle plates.

The proposed test setup requires a minimal structural test facility having a structural floor with embedded reaction rails, but no structural reaction wall, and a maximum hydraulic ram load of 50 kips. There are also applicable ASTM standards (E72, for example) for structural testing of walls including quasi-static cyclic loads, as well as acceptance criteria published by International Conference of Building Officials (ICBO Evaluation Service, Inc.) which may also be considered.

The equivalent bending thickness  $t_{eq}$  of a uniform plate has been approached analytically as in the previous section (also see Salse, 1987, and Pesce, 1996), or numerically by finite element methods (Shugar, et al., 1991). Ultimately, all such novel approaches for reinforced concrete waffle walls should be verified experimentally.

It is noted that the steel reinforcement is a 15" x 15" grid for the particular waffle plates of interest (RASTRA, 1996; ENER-GRID, 1996), and it is believed that at least four grid widths should be included in a test article to derive the benefit of plate-like behavior in the test results. Therefore both of the proposed tests assume a 60-inch wide panel, which has a standard 10-inch overall thickness (grid member diameter is 6") and an 8-foot length (a 10-foot length could also be used), as shown in Figure 3-1. The #4 steel rebar is assumed to be at the center of the concrete infill. At an assumed unit wall weight of 40 psf (RASTRA, 1996; ENER-GRID, 1996, walls are slightly heavier), the proposed test panel would weigh 1600 lbs. It is composed of 45% reinforced concrete infill and

55 % cement/polystyrene formwork. In contrast to dealing with an entire wall, the test load and cost in the structural laboratory may be reasonably limited by using the proposed panel test article. Assuming stiffness is linear with wall length, the results obtained would extrapolate to the behavior of an entire length of load bearing or shear wall. However, it would be necessary to conduct additional testing with different widths to verify this assumption. Additional permutations could include #3 rebar instead of #4 rebar, and possibly diagonal rebar, or variable reinforcement in the horizontal and vertical directions. Other configurations are possible.

### 3.1 Proposed Panel Buckling Capacity Test

In the proposed test an edge load is applied to a test panel as shown in plan in Figure 3-2. The load  $P$  and the lateral deflection  $\Delta$  are the quantities to be measured. From these data the elastic load bearing capacity of the panel,  $P_{cr}$ , can be determined, from which the plate stiffness  $D'$  including the equivalent thickness  $t_{eq}$  of the plate can also be determined. The proposed test is an extension of a nondestructive test for columns, known as a modified Southwell test.

Southwell (1931) devised a method by which linear elastic test data from a column with initial curvature could be analyzed to determine the buckling capacity which the member would have if it were perfectly straight. This concept can be illustrated with the aid of Figure 3-3 where it is applied to the proposed test article. In this figure, Southwell's method would correspond to zero eccentricity,  $e = 0$ , for the axial load on a panel having initial curvature with amplitude  $a$ . Upon loading the lateral deflection  $\Delta$  would be measured, and a graph would be constructed as shown. It is known that this graph must be a straight line with slope equal to the buckling capacity for a corresponding perfectly straight member,  $P_{cr}$ . That is,

$$\Delta = P_{cr} v + b$$

where abscissa  $v \equiv \Delta/P$  and where the negative intercept is  $b = -a$ , the initial bow amplitude of the test article.



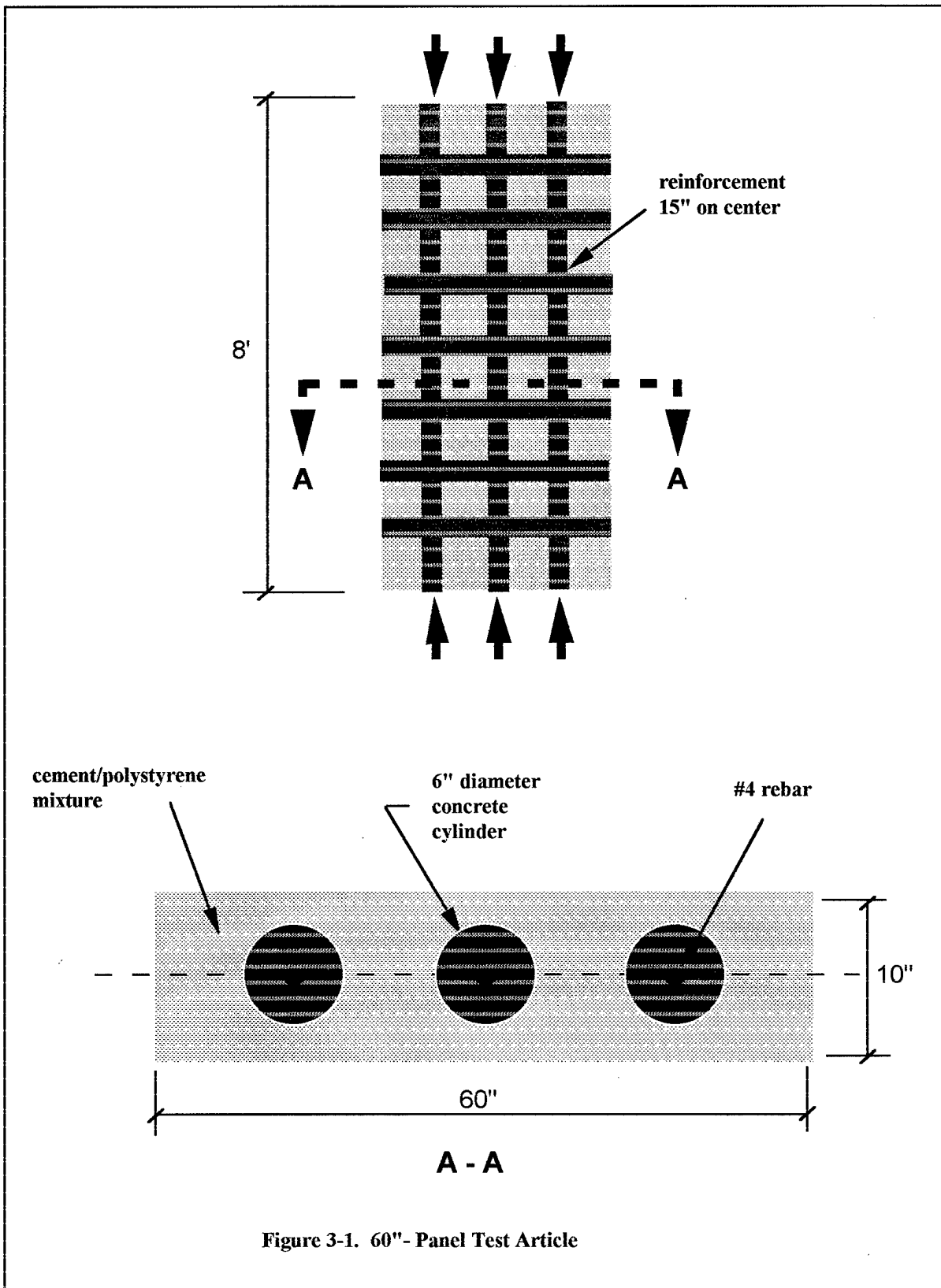
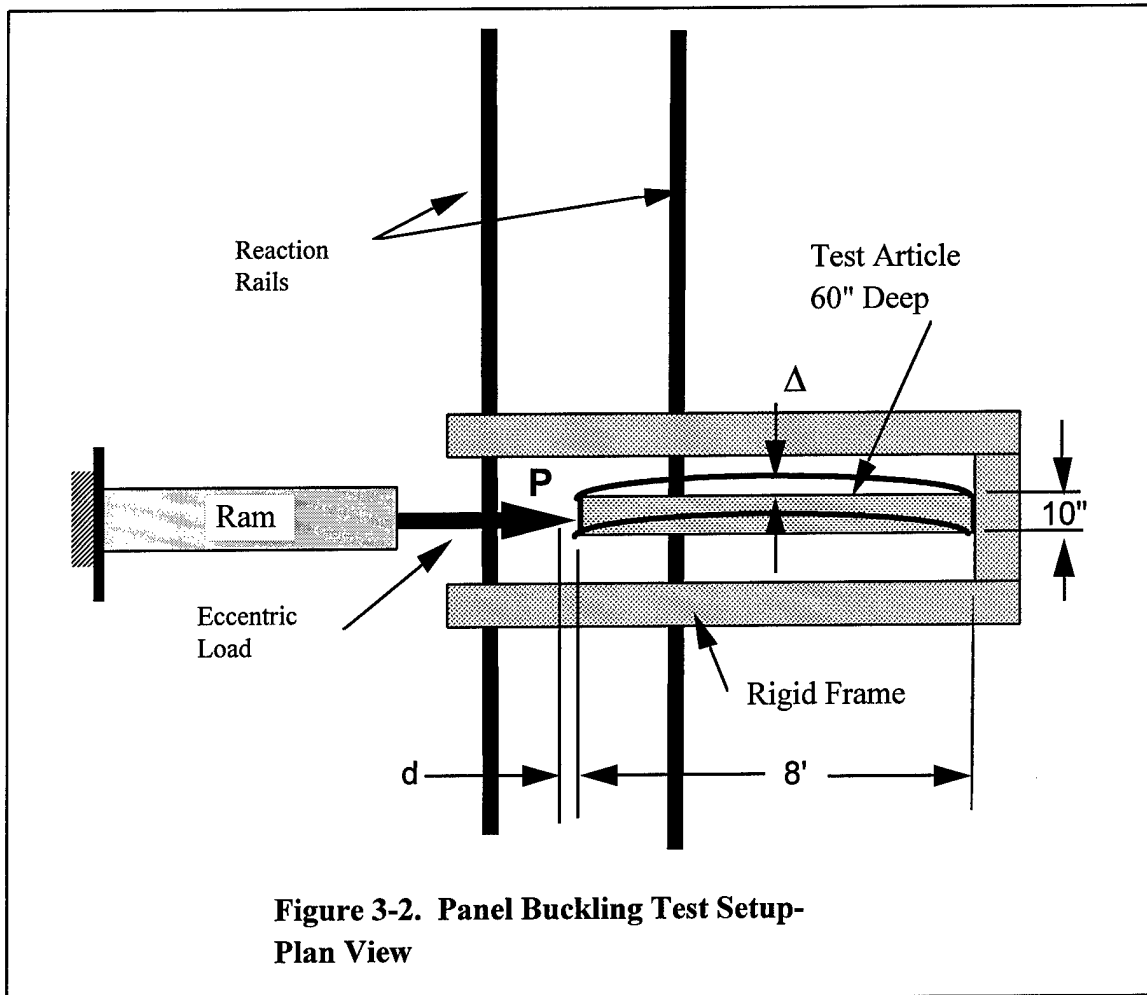

Figure 3-1. 60"- Panel Test Article



Southwell's equation will not work for a member with no initial curvature since, for such a member, there would be no lateral deflection until the instant of failure, when the buckling load is reached. This is likely to be the case, or nearly so for the waffle panel, since it is carefully manufactured with molded and machined cement/polystyrene formwork, though it will also depend on how symmetrically its reinforced concrete infill is placed. With an eccentric load, however, the method can be made to work and is referred to as the modified Southwell method. The modified equation is, to a reasonable accuracy according to Tsai (1986), the aforementioned straight line equation, with a negative intercept equal to

$$b = -(a + 1.234 e)$$

Thus, irrespective of how imperceptible the initial bow amplitude, a sufficient eccentricity value  $e$  may be selected with which to conduct the test, and obtain the buckling capacity of the panel. In this way, the buckling capacity of the panel and its associated bending stiffness properties can be estimated with tests at low axial load since the load is applied with an eccentricity.

An estimate for the buckling capacity of the panel can be simply made assuming only the load-bearing grid of the panel resists load and only one-way bending takes place as proposed in Section 2.0.. The panel can then be treated as an unbraced one-dimensional compression member. Any flexural strength and/or bracing/confinement effects provided by the surrounding cement/polystyrene formwork are neglected in this estimate. Further, since the #4 steel rebar is located in the center of each strut, its flexural capacity may be safely neglected. Based upon the sketch in Figure 3-1 which shows three vertical concrete struts in compression for the proposed panel, the buckling capacity estimate is taken as the smaller of the elastic buckling capacity of the panel,  $P_{cr}$ , or the ultimate compression load (reduced by a factor  $R \leq 1$  for slenderness with slenderness ratio  $l/r$ )  $RP'_u$ . That is,

$$P_{max} = P_{cr} \text{ or } 3xRP'_u$$

where,

$$P_{cr} = \frac{\pi^2 D'}{a^2} xb$$

$$D' = EI_{eq}$$

$a$  = panel length

$b$  = panel width

and,

$$P'_u = \phi f'_c A_c + f_y A_s$$

$$R = 1.07 - 0.008 \frac{l}{r}$$

The use of  $I_{eq}$  indicates that the derived waffle-wall thickness with a cracked section is considered (Section 2.4). The reduction factor  $\phi$  accounts for fast load rates in compression tests of concrete, and  $f'_c$  is the unconfined concrete strength. (See Table 3-2 for additional information regarding these terms.)

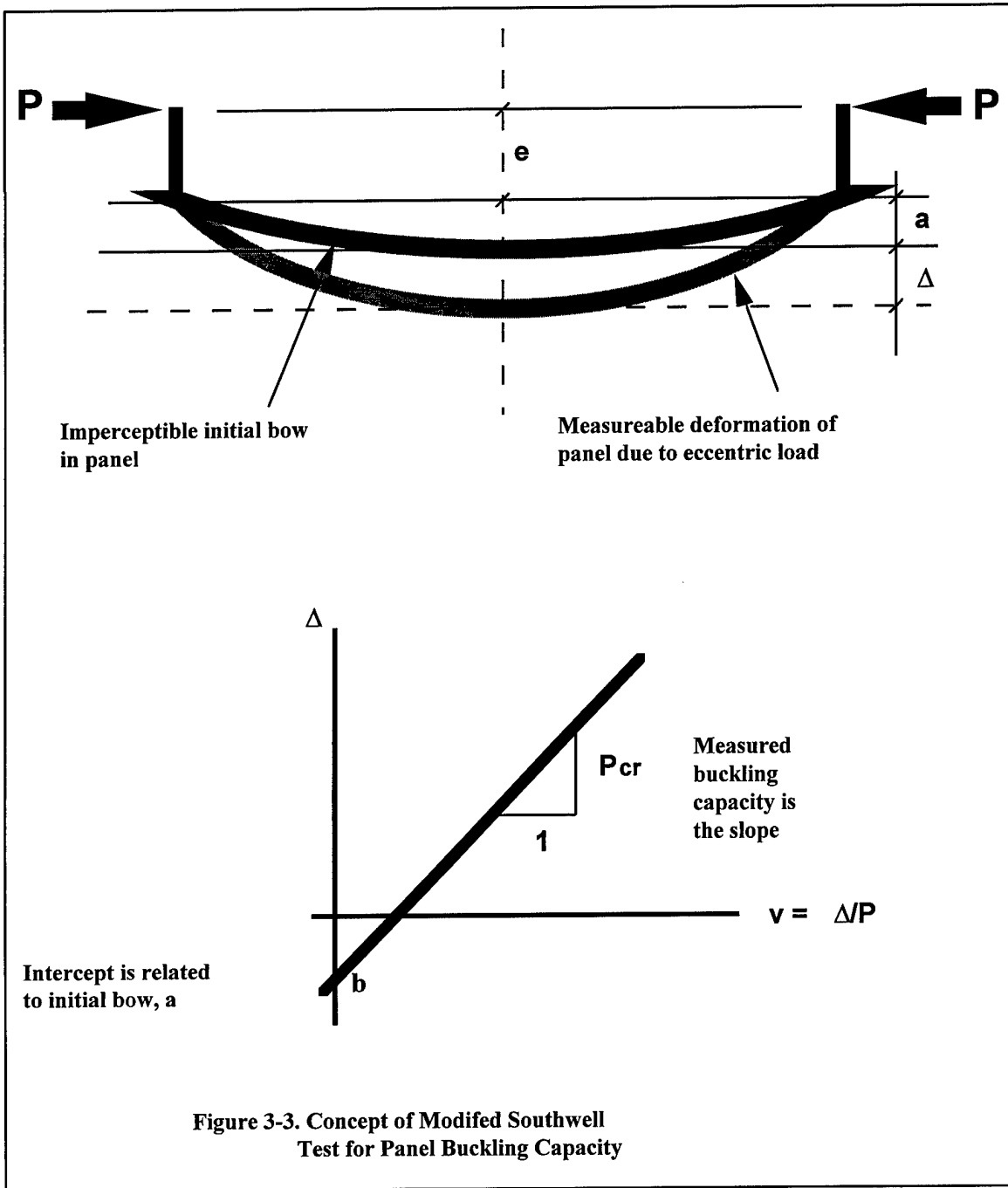

Figure 3-3. Concept of Modified Southwell Test for Panel Buckling Capacity

It is emphasized that the existing modified Southwell test concept is otherwise sound for columns behaving elastically, and it is also a nondestructive test concept, but it is not known for testing panels or plate-like compression members, as proposed. Further, many details of the eccentric load actuator, instrumentation and data acquisition system, etc., need to be worked out.

### 3.2 Proposed Panel Shear Capacity Test

A plan sketch of the proposed shear panel test setup is shown in Figure 3-4. The goals of the test are to determine the panel's elastic stiffness, and its ultimate strength in wracking. Further, this test should be run in two configurations: cantilevered or fixed at one end (as shown), and fixed at both ends (see below). The stiffness of lateral load-resisting elements such as shear walls or piers is based on whether the element is assumed to deform as a cantilevered pier or a fixed-fixed pier. Data for both conditions should ultimately be available to the structural designer as they currently are for reinforced concrete and masonry wall systems.

This test should also be conducted with the addition of a longitudinal load to simulate the effect of vertical or bearing loads on walls. This more extensive test concept is illustrated for a test panel (fixed at both ends) in the sketch in Figure 3-5. The longitudinal load could be provided by adjustable steel tie rods (not shown) running from the load cap to the foundation on either side of the test panel. Here it is assumed that the ultimate failure mode is a direct shear failure (as contrasted with an alternative flexural failure mode) just above foundation support. This support could be provided by #6 dowels spliced into the panel and with standard hooks embedded into a concrete footing. Ideally the dowels should be tied to the vertical #4 bars in the panel.

Assuming the aforementioned mode of transverse shear failure holds, the ultimate load for the test panel can be simply estimated. Again, the strength of the cement/polystyrene formwork surrounding the struts is neglected. Thus, the ultimate shear force for the test panel is given by,

$$F_{\max} = 3F_u = 3(v_{uc} A_c + f_{us} A_s)$$

where  $v_{uc}$  and  $f_{us}$  are the ultimate shear strength of concrete and steel rebar, respectively.

### 3.3 Estimated Structural Test Parameters

The maximum loads given by the aforementioned estimation formulas have been calculated and listed in Table 3-1. Qualitative engineering estimates for the corresponding deflections of the test panels are also provided in this table. Load estimates are based on the assumed properties of the test panel given in Table 3-2.

The estimate of the buckling capacity for the panel indicates that the elastic buckling load is just smaller than the (reduced) crushing strength (i.e., the inelastic buckling load). However, recall that the theoretical calculations involving a square waffle wall indicated that the inelastic buckling load should govern (Figure 2-13). It is important to conduct structural tests to determine which mode of buckling takes place, elastic or inelastic.

The proposed structural tests and preliminary estimates are intended as a basis for a comprehensive test plan wherein many remaining details must be addressed.

Substantial structural testing of waffle walls is currently underway at the University of California, Irvine, and elsewhere. These tests are sponsored by industry and are aimed at certification by ICBO, Evaluation Services, Inc., pursuant to their acceptance criteria. The data from these tests may provide much of the required data sought in the proposed tests herein if and when it is released to the government.

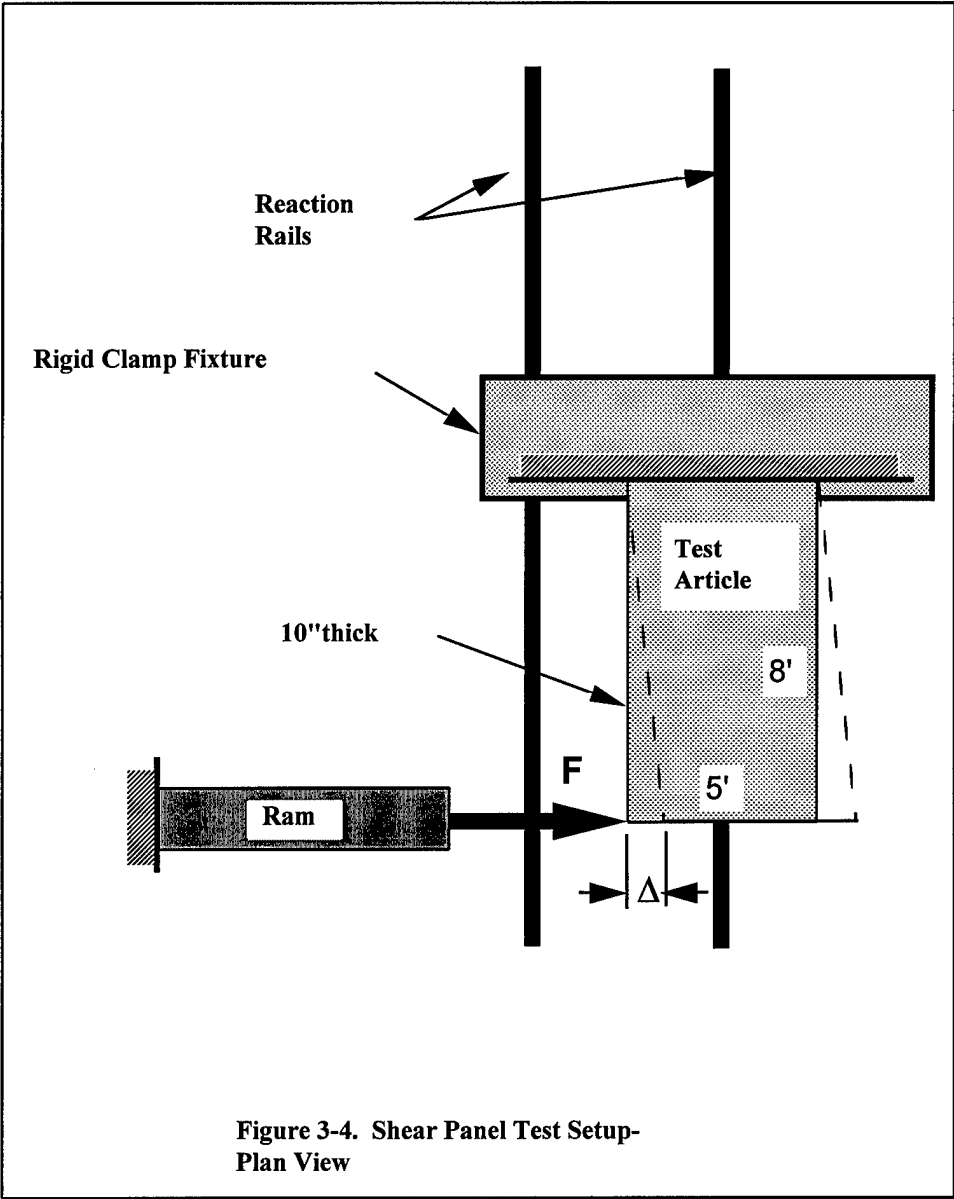
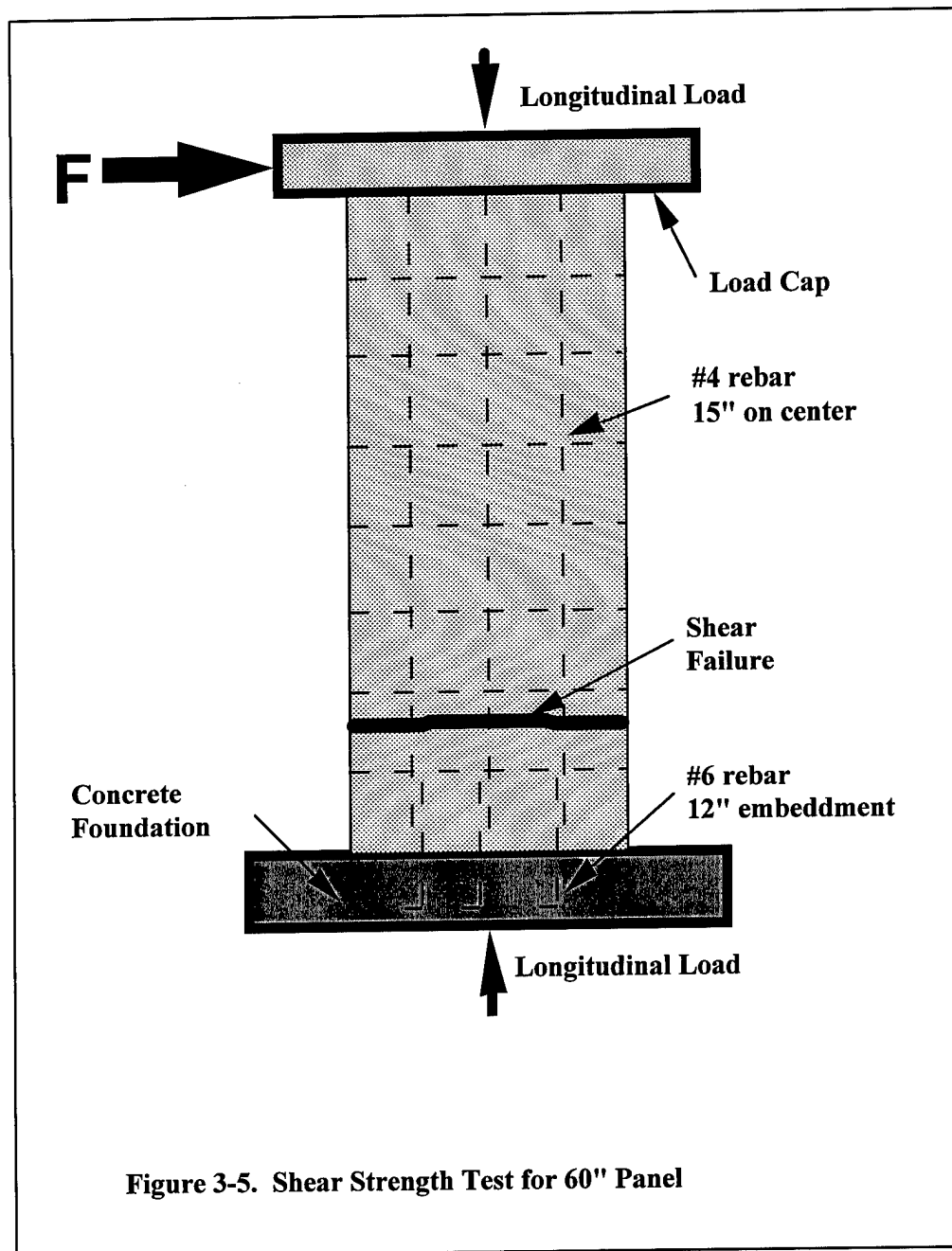

Figure 3-4. Shear Panel Test Setup-  
Plan View





**Table 3-1. Test Parameter Estimates for a  
60"-Wide, 8'-Long Waffle Panel**

Panel Test	Maximum Load, $P_{max}$ or $F_{max}$ (kips)	Maximum Panel Deflection, $\Delta_{max}$ (in)	Maximum Ram Travel, $d$ (in)
Elastic Buckling*	105	1 - 10	0.1 - 1.0
Inelastic Buckling	113	1 - 5	0.1 - 0.5
Shear	25	1 - 2**	1 - 2

\* This is a non-destructive test (i.e., a modified Southwell buckling test) so that this estimate of maximum ram load, is not significant to laboratory testing.

\*\*The maximum deflection for the shear test depends on the amount of longitudinal compressive load applied to the panel since axial load reduces the transverse stiffness of members.

**Table 3-2. Assumed Values for Test Panel Properties**

Property	Assumed Value
unit weight of concrete, $w$	145 pcf
compressive strength of concrete, $f'_c$	2,000* psi
modulus of elasticity of concrete, $E$	$2.57 (10)^6$ psi
equivalent moment of inertia, $I_{eq}$	$0.635 \text{ in}^4/\text{in}$
panel length, $a$	96 in
panel width, $b$	60 in
modulus of elasticity of steel, $E_s$	$29 (10)^6$ psi
slenderness ratio, $l/r$	61.1
effective length parameter, $k$	1
slenderness reduction factor, $R$	0.58
under strength factor, $\phi$	0.85
yield strength of steel, $f_y$	60,000 psi
ultimate shear strength of concrete, $v_{uc}$	76 psi
ultimate shear strength of steel, $f_{us}$	30,000 psi

\* This value should be changed to 3,000 psi for application to earthquake resistant design in seismic zones 3 and 4.

#### 4.0 SUMMARY AND CONCLUSIONS

Waffle walls are a new building construction concept for small commercial building and residential housing applications. These walls are constructed of cement/polystyrene block-like elements which are in-filled with liquid concrete and steel reinforcement. The resulting load bearing component of the wall is a monolithic structural element that appears waffle-like in form, and functions similar to a stiffened plate.

A preliminary analysis approach for the vertical load-bearing capacity of waffle walls was investigated. The proposed approach is based on classical thin plate buckling theory. The coupled two-way action common to continuous plates is uncoupled to replicate the perceived behavior of waffle walls. An equation for the critical edge load is derived in terms of an equivalent thickness, assuming the wall remains elastic and for the simply-supported case. Inelastic buckling is also investigated because of the highly inelastic behavior of concrete in compression. In this buckling mode the vertical load capacity of waffle plates would be reduced. To apply this theory, an equivalent bending thickness for waffle plates needs to be assigned empirically using the theory presented including the equivalent thickness equation derived as a guide.

Two types of laboratory static structural tests are proposed using a configured section or panel of a waffle wall for a test article. A version of the so-called modified Southwell nondestructive test for compression members is proposed for determining the critical edge load of the panel as well as the transverse bending stiffness of the panel, and hence the equivalent bending thickness of waffle plates. A conventional wracking shear wall test is also proposed to measure the in-plane stiffness and capacity of the panel when subjected to lateral load to support design of waffle walls to resist both wind and earthquake forces.

## 5.0 REFERENCES

"Acceptance Criteria for Concrete and Masonry Wall Systems," ICBO Evaluation Service, Inc., Whittier, CA, June 1987

Brush, D. O. and B. O. Almroth (1975). "Buckling of Bars, Plates, and Shells," Art. 3.8, McGraw-Hill Book Company, Inc., New York, 508 pages.

Burke, D. F. and T. A. Shugar (1997). "User's Guide for Cement Ploystyrene Forms for Poured-in-Place Reinforced Concrete Walls," UG-XXXX-SHR, Naval Facilities Engineering Service Center, Port Hueneme, CA 93043 (in publication)

ENER-GRID (1996). ENERGRID, Riverside, CA 1996.

Jaeger, L. G. (1964). "Elementary Theory of Elastic Plates, Chs. 1 and 6, Pergamon Press, Ltd., 108 pages.

Pesce, G. V. (1996). "An Introduction to the Application of Concrete Post and Beam Construction Using Lightweight Insulative Forms in Building Design," Draft Version, Castleblock, Ventura, CA 1996.

RASTRA Building System (1996). RASTRA Technologies, Inc., Lichfield Park, AR., 1996.

Salse, E. A. B., (1987), RASTRA Building System, Letter Report, Construction Technology Laboratories, Inc., Skoie, IL, 21 May 1987

Shugar, T. A., T. J. Holland and L. J. Malvar. (1991). "Advanced Finite Element Analysis of Drydocks and Waterfront Facilities - A Technology Assessment," TN-1835, Naval Civil Engineering Laboratory, Port Hueneme, CA 93043, October 1991.

Timoshenko, S. P. and J. M. Gere (1961). Theory of Elastic Stability, Art. 9.12, 2nd Ed., McGraw-Hill Book Company, Inc., New York, 580 pages.

Tsai, W.-T. (1986). "Note on Southwell's Method for Buckling Tests of Struts," Journal of Applied Mechanics, ASME, Vol. 53, 953-954, 1986.

Uniform Building Code (1994), Vol. 2, Structural Engineering Design Provision, ICBO, Whittier, Ca., May 1, 1994.