

EW TESTING LESSONS LEARNED

**Paul H. Berkowitz, Executive Vice President
Electro-Radiation Inc.**

Track: SOS/DST Tuesday 6/16/98

ABSTRACT

Electronic Warfare (EW) testing is one of the more challenging undertakings in the Avionics community. EW tests are typically fraught with a myriad of problems due to the inherent complexity of tests involving multiple vehicles, radars, data collection, and data processing, as well as the complex nature of Electronic Warfare itself. Electro-Radiation Inc. (ERI) has been at the forefront of EW testing for many years, from B-52 to B-2 and from F-101 to F-22. While it is impossible to prevent all problems, it is possible to prevent the same problems from repeating. This paper applies many of the lessons ERI learned from its extensive EW testing experience, and offers recommendations of how to avoid repeating them.

1.0 INTRODUCTION

Electro-Radiation Inc. (ERI) has been a leader in the field of Electronic Warfare (EW) testing for many years. During this time, it has been seen that the complexities of EW testing create an enormously challenging environment. A typical EW flight test involves multiple aircraft, both jammers and victims; ground test radars; ground reference radars; airborne reference radars; a central facility for real time flight and test control; telemetry and displays for real time observation; data collection; post data processing to generate error information; a laboratory to test and program the EW system, with associated signal sources, meters, scopes, monitors, test boxes, reprogramming tools, and spares for emergency repair/rework; and a classified work area with data storage for manuals and test data.

For any single day's test, as many as 50 people from several Government agencies and contractors can be involved. In the center of this is the EW tester, who has responsibility for about 100 variables and control of perhaps 3. Given this complex scenario, it is not surprising that many problems arise. It is virtually impossible to run such an enterprise without problems. However, there are several problems that tend to occur quite often. It is these "repeat offenders" that can be eliminated fairly simply, with some careful foresight and planning. This paper presents several of these problems, and recommendations of how to eliminate them in the future, with the benefit of ERI's years of EW test experience hindsight.

There are several areas where issues arise in EW testing. These include:

- AIRCRAFT
- RANGE
- TEST
- DATA

19981029 100

2.0 AIRCRAFT ISSUES

When a new piece of equipment is installed in an aircraft, it must be integrated both physically and functionally. Most aircraft issues are related to the physical equipment installation. Functional integration usually proceeds fairly smoothly, since it is possible to test most interfaces with the actual equipment or a software simulation of that equipment. Most problems arise when the physical interface is different on the aircraft than in the lab, such as cable sizes and lengths; or when spatial functions, such as Direction Finding (DF) and sector crossover, are being tested for the first time.

2.1 Cabling

When Line Replaceable Units (LRUs) or "black boxes" are tested in the laboratory, they are usually placed side-by-side on a bench or fixture, with relatively short interconnecting cables. When those same LRUs are installed in the aircraft, they may be separated by tens of feet. Additionally, the actual cable runs may be much longer than that, due to connectors, bulkhead feedthroughs, etc. **Figure 1** illustrates these potential differences. A system that works perfectly on the lab bench, may encounter problems when installed in the aircraft due to the different cabling. Cable lengths can affect signal characteristics, such as timing, rise and fall times, driver loading, and voltage drops.

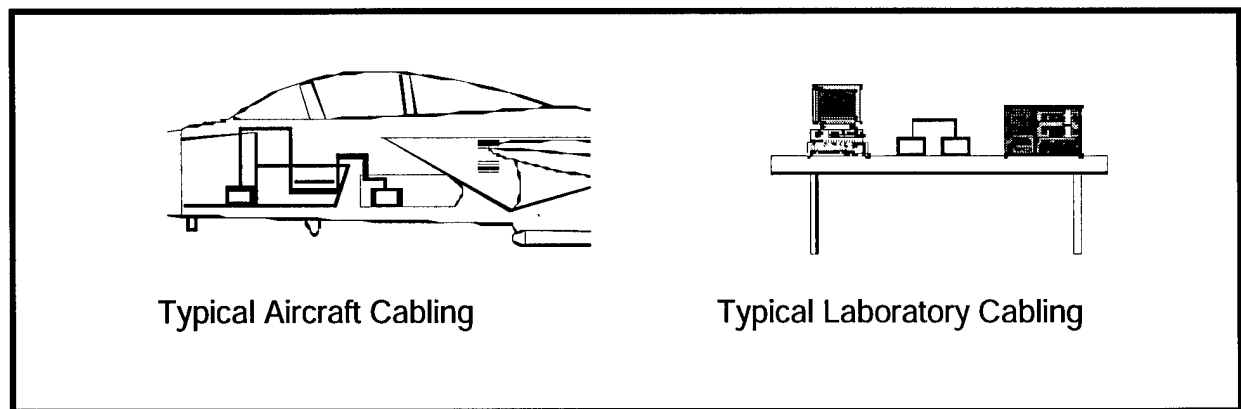

Figure 1 - Lab Cabling vs. Aircraft Cabling

Timing can create insidious problems, such as when blanking just fails to cover a potential interferer, and a sliver of undesired signal corrupts system performance. ERI experienced this during a B-52 EW flight test. A processor Line Replaceable Unit (LRU), or "black box" was installed near the crew station, and a direction finding (DF) receiver was under the nose radome. Because of the size of the B-52, the cable run was tens of feet long. The blanking signal to the DF receiver to protect it from seeing the EW system transmission was arriving just late enough to intermittently allow the interference. When the problem was finally diagnosed, it was easily fixed by adjusting the blanking signal timing.

Unexpected voltage drops can also create intermittent anomalies which can be extremely difficult to diagnose and correct. These problems are not limited to large aircraft like B-52s. A

recent ERI Global Positioning System (GPS) Interference Suppression Unit (ISU) test on a Falcon-20 business aircraft flights were lost due to an unexpected voltage drop in a DC power line. The line losses were enough to drop the +5 volts at the power supply down to +4 volts at the ERI LRU. To further complicate the issue, the voltage was high enough to enable ERI's system to turn on, but not high enough for the circuitry to function properly. Two flights were lost due to this problem.

The best solution to avoiding installed cabling problems is to use the same cables in the laboratory as in the aircraft. The simplest approach is to have two cable sets built for the aircraft, and use one in the lab. Then if any timing, loading, or loss problems arise, they can be solved in the lab. If schedule or cost considerations prevent using this approach, the next best option is to obtain the aircraft installation drawings and estimate the installed cable lengths and connections. Then a lab cable set can be built to the same design. Both of the examples cited could have been avoided had this approach been adopted.

2.2 DF and Sector Crossover

Direction Finding (DF) and sector crossover problems are very common in EW flight tests. Often, this is the first opportunity to actually radiate to and from the system, which is required to stimulate the DF and sector crossover functions. Additionally, this is almost always the first time these functions operate under dynamic conditions. To complicate the issue, there is limited control of the environment during flight test, making analyses, diagnoses, and correction difficult. Finally, aircraft installation can also affect performance, due to alignments, blockages, reflections, etc. These problems are very difficult to troubleshoot in flight. The true data reference requires accurate position, heading, and attitude data for the aircraft. Correlating the on-board (DF) data with the off-board (true) data is a data processing challenge. Additionally, there is very limited, or no, real time observation of the EW system possible during operation.

There are three parts to the answer for DF and sector crossover issues. Each solution has merit on its own, and applying all three is ideal. The first solution is to place the system in an anechoic chamber in the laboratory. The chamber does not have to be huge, or super "quiet". It need only fit the relevant Black Box with its antennas and radomes, and be large enough so that both the system antennas and test antennas are operating in the far field. The isolation must be enough to ensure personnel safety, and prevent interference with other lab activities. This will enable radiating tests with controlled conditions. Real time observation of all parts of the EW system is feasible, and correlation between measured DF and true data is simplified. Additionally, a full set of laboratory diagnostic equipment should be available with the design experts on call. The DF and sector system performance can be isolated from aircraft installation effects, resulting in a well defined performance baseline prior to flight test. Dynamic testing is somewhat limited, but even that can be simulated to some degree by programming a threat generator to "fly" through a defined scenario.

The second solution is to test the system installed in the aircraft in the Benefield Anechoic Facility (BAF) at Edwards Air Force Base. The BAF houses the largest anechoic chamber in the world as shown in **Figure 2**. It measures 264 x 250 x 70 feet and can accommodate virtually any existing military aircraft. The Radar Absorbent Material (RAM),

shielding, and free-space volume provide an ideal test environment, free from interference, with repeatable test conditions. It includes an 80 foot diameter turntable which can rotate over

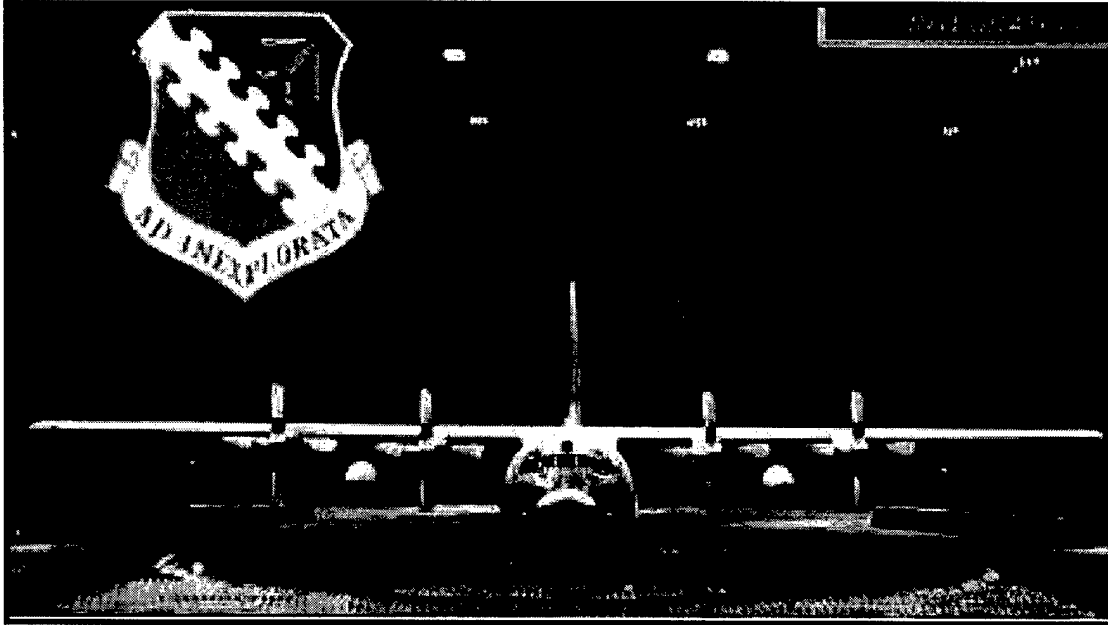

Figure 2 - Benefield Anechoic Chamber

250,000 pounds, $\pm 190^\circ$, with 0.05° resolution. This enables DF and sector crossover testing of the installed system in a controlled environment. Untold hours of flight testing can be eliminated by judicious use of the BAF.

The third solution is to develop a "walkaround" aircraft tester. This can range from a formal piece of flight line test equipment, to an informal cart full of laboratory test equipment and an extension cord. While the aircraft is on the flight line, DF can be evaluated on the installed system by radiating from the cart to the aircraft from previously marked angle positions. This enables limited DF troubleshooting under static, but installed conditions. The set-up is less than perfect, since there can be multipath from the ground or nearby structures. However, careful selection of location, coupled with a few panels of RF absorber material scattered on the ground between the cart and the aircraft, can all but eliminate the potential interference. A fringe benefit of such a test set-up is that it can be used for a confidence check prior to each flight test. Before takeoff, the installed system can be verified to be receiving and transmitting properly, before costly flight test assets are committed. It was the assembly of such a walkaround test cart that enabled the diagnosis and fix of the aforementioned B-52 DF blanking problem.

3.0 RANGE ISSUES

In order to evaluate Electronic Warfare performance, specialized test ranges are required. These have the necessary threats and threat simulators, as well as physical security to enable uncompromised classified testing. Due to the assets and physical spaces required, there are a

limited number of ranges available. As unique as each is, they all tend to suffer from the same issues, driven by threats, scenarios, multipath, and new threat assets.

3.1 Threats

The categories of threats that are typically encountered during EW flight testing include:

- Surrogates - Friendly systems used in place of real threats
- Simulators - US build replicas of real threats
- Real Threats - Actual threat systems

Each of these have potential problems which must be addressed.

EW systems are usually designed against a formal list of threats defined at the start of the program. These threat parameters are used to define threat identification tables, algorithms, etc. Although the EW systems are reprogrammable, the baseline programs are based on the defined threat data. If the systems encountered during testing are not consistent with the real threat data, the EW system will not be able to perform properly, and test results can be severely impacted.

Surrogates by their very nature are not likely to match the real threats in all categories. They may have parameters outside the real threat ranges, waveforms different from the real threat, or modes different from the real threat. Even when these are identified, they can be difficult to solve. An EW flight test was run using an F-106 as a surrogate for a Soviet fighter. The F-106 radar had a PRI modulation not present in the real threat, therefore the PRI modulation circuit was disabled. The EW system detected modulation and made the wrong identification (ID). The EW system engineer met with the radar manufacturer's representative, who showed the schematics, and the capacitor which coupled the modulation which he said he removed. Out of frustration, the EW system engineer requested the removal of the radar unit from the aircraft for inspection. Luckily, the field rep was not insulted by the request and did so. The radar unit was opened on the radar test bench, and sure enough the capacitor was removed. Power was hooked up to the unit so the circuit output could be seen. The capacitor was replaced, and the PRI circuit exhibited the modulation. The capacitor was then removed and the PRI exhibited more modulation than before! Since there had never been a need to remove the modulation, the underlying signal had probably never been examined before. With a simple modification the circuit was connected to a crystal, creating a PRI signal which matched the threat. From then on, the EW system ID'd perfectly. Only because a junior engineer was naive enough to ask to see for himself, and a senior field rep was kind enough to indulge, was this problem discovered and fixed. (I am to this day grateful to him.)

Simulators may not match the real threats because they may have been built using older threat data, using current data but from a different intelligence source than the EW program data, or they may have been modified since original design. Even real threats may not match program data, since the threat systems may be aligned to extremes or have substitute repair parts which create signals outside the defined ranges. Simulator and threat alignment has often been a problem for EW system testing. In at least two cases of real threats ERI has been involved with, the alignment procedures developed by the US operators went far beyond the radar manual instructions. Both examples had defined alignment procedures which were difficult to implement and could drift with time. They were replaced with new procedures which were really only

applicable to test conditions and could not have been used in the field, but significantly increased the radars resistance to jamming. This put the EW systems at an artificial disadvantage during testing against these two threats. Even worse, in both cases it was EW engineers who showed the radar operators how to better align the systems! As Pogo said - we have met the enemy and he is us.

The solution to all of the above potential problems is the same - measure and verify each threat system on the test range that the EW system will encounter. This requires getting portable equipment into the field, to measure and record all critical parameters, such as frequency, PRI, jitter, pulse width, etc. The recorded data can then be used to program signal generators in the laboratory in order to test the EW system with the test range threats. The EW system can then be modified for operation with the test threats. This may include reprogramming threat ID tables, modifying threat lists, and/or adding a TEST mode for test range threats only.

3.2 Scenario

Most EW tests are planned to include a limited number of threats at any given time. **Figure 3** illustrates a typical planned scenario. This enables easier interpretation of results when initially working one-on-one, and holds down range costs. After the individual tests, one-on-many tests are run to ensure operation in a realistic environment.

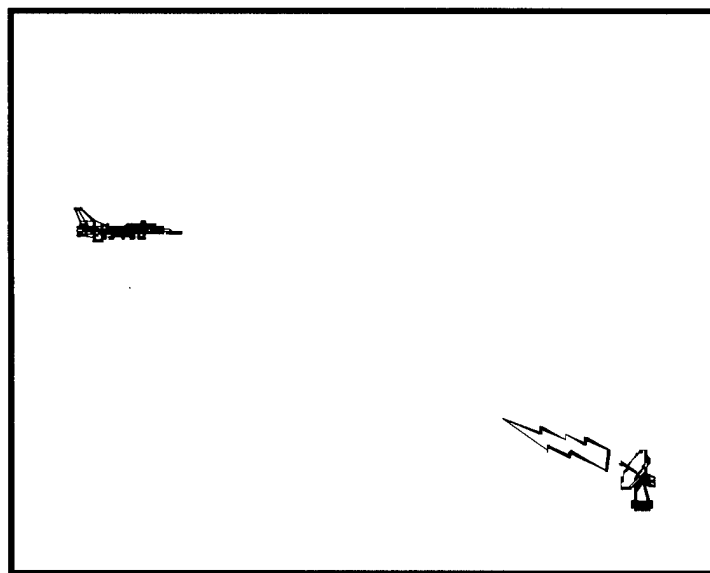

Figure 3 - Typical test scenario planned

The potential problem is that the range assets are not always totally controlled. Test sites may be transmitting for maintenance or calibration. Operators may want to track a target of opportunity for practice. If the aircraft is a low observable (LO) vehicle, it is very tempting for an operator to try to detect it. Another possibility is that there may be other tests going on within the radar horizon. Even large test ranges have limited airspace, and there are usually co-located or nearby bases flying routine training missions. ERI has found that at a typical EW test range like Eglin Air Force Base there are always F-15s flying nearby, creating a nearly continuous

high pulse density background. Again, in the case of an LO vehicle, there is the additional temptation for them to try to find and track it. The bottom line, is that despite the best of intentions, the scenarios encountered are usually outside the test plan as shown in **Figure 4**. This can impact the testing by tying up limited EW system resources on non-test signals and which can bump test threats from limited EW system resources, resulting in a form of unexpected interference.

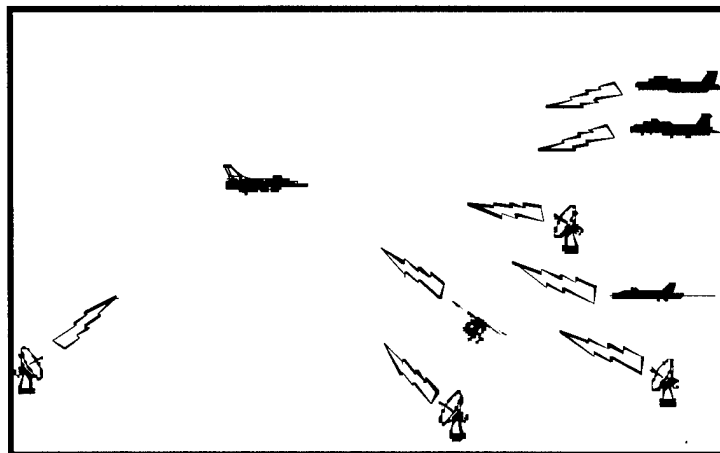

Figure 4 - Typical test scenario encountered

The solution to scenario issues is similar to the threat issues - identify the potential problems and solve them in the lab before getting to the test range. Identify all the threats on the test range, to provide definition of possible unintended signals which may be encountered during testing. This includes ground assets and locations, airborne assets, and nearby air and naval assets. Then program the laboratory signal generators with the potential unintended signals. Layout the ground sites the same as they are on the range and add in a mix of on- and off-range airborne signals. This will enable evaluation of the worst case likely to be seen on the test range.

3.3 Multipath

Another form of unintended signal corruption possible during flight test is multipath. During low altitude flights, both received and transmitted signals can be reflected off the ground and added to the direct path signal. This distorts the signals in both directions, by adding time varying amplitude and phase modulation, and stretching the pulse width. This can impact threat identification and jamming. Pulse width threat ID can be affected, and any retrodirective jamming techniques can be corrupted by the multipath AM and PM. In early B-1A monopulse EW flight tests conducted by ERI personnel at 200 feet, the effects of multipath were disastrous. It took multiple flights to solve the problems. Fast forward 15 years, and a B-52 EW flight test at 500 feet suffered many similar problems. ERI was called in to assist, and not surprisingly, the same solutions installed in the B-1A EW system, were implemented in the B-52 EW system, and the multipath problems were again solved. Despite the reputation of B-1 EW, it saved the day for the B-52.

Since multipath is a physical phenomenon, it cannot be eliminated. If required to fly at low altitude in the real world, the EW system must be able to work in the presence of multipath. The solution is to simulate multipath effects in the laboratory. The effect can be calculated for the planned flight geometry. Multipath can be created in the lab by coupling a sample of the signal with the anticipated delay and reflection loss. Adding random amplitude and phase modulations increase the fidelity of the multipath simulation. Typical EW system modifications to enable operation in the presence of multipath include adjusting pulse sampling times, adjusting measure and set update rates, and stretching jam pulses to cover the delayed reflection.

3.4 New Assets

One problem that seems to reoccur in EW testing is when the system is scheduled to be the first to test against a new threat asset. Although it should not matter, ERI has found that the first test against a new asset tends to be very inefficient. There is usually more time spent troubleshooting the threat asset than testing the EW system. Additionally, the lack of a threat performance baseline creates difficulty in interpreting results. ERI's experience dictates that the first test on an asset always takes longer than planned.

There are no real solutions to this potential problem, but there is a way to minimize its impact. The best option available is to schedule the new asset at the end of the EW system test sequence. If there are problems with new asset, the impact to the other tests is minimized. If the test cannot be completed within schedule, it will likely be necessary to cancel or postpone the new asset test. If postponed, the return may be after the asset has matured, eliminating the problem.

4.0 TEST ISSUES

Due to the complex nature of Electronic Warfare evaluation, the test process itself, has many issues. These include EW system configuration, operator learning, operator cooperation, and operator observations.

4.1 System Configuration

The two primary potential problems are the risk of uncertainty in EW system parameter settings and multiple EW setting changes between test runs. System changes are often made between test runs in order to maximize the amount of data during a flight, especially during optimization and development testing. Under short time and intense pressure, it is easy to forget to record the details. This can later cause chaos during data analysis, when it may be difficult to recreate the information. This creates obvious challenges in interpreting the test data. The second problem is caused by changing multiple settings between runs. If performance gets better (or worse) it is difficult to determine which of the multiple changes (or combination) was the cause.

The solutions for both are essentially to adhere to the discipline of good test engineering practice. In order to insure that an accurate record of system settings and events is recorded, ERI

assigns an individual, who is outside the decision making loop, the full time task of religiously recording all pertinent data. This includes start and stop times of all runs, all system parameters for each run, and any observations or contemporaneous comments made by any participants. This will insure a complete and accurate record which becomes invaluable during data analysis. In order to prevent ambiguous results, a similarly disciplined approach to system changes is required. ERI assigns the final say for real time changes to a single individual for consistency and to maintain control for the test discipline. He is tasked to limit changes to a single parameter between runs, and also to attempt to bracket a good setting to establish confidence that it is optimum.

4.2 Operator Learning

EW versus automatic systems is a waveform versus processing battle, which typically provides very consistent results. If it works, it will work over and over again. EW versus a human operator is more a battle of wits, because the human operator learns every time he sees the EW waveform. Since the effect is one of deception, surprise is a large part of the success. If the human operator is given enough time, eventually he can discern even trivial clues which he can use to negate the deception. For example, if the EW system uses a cover pulse, a wide noise pulse to cover the real target return, it can prevent accurate range tracking. Additionally, this will create a situation where the radar angle tracking circuits only see jamming, with no aircraft skin signal (this is known as an infinite Jam-to-Signal ratio), enhancing the chances of angle errors or breaklock. But since the cover pulse frequency will not be exactly the same as the radar frequency, the two frequencies will beat against each other, creating a "birdie" where the real target is. This can be masked but not eliminated. Given enough time, a radar operator can eventually learn to isolate the birdie. Another subtle but potentially useful cue is when the baseline lifts slightly under a false target which covers the real signal. This is known as a "the mouse under the rug".

There are two aspects of EW testing that make the process vulnerable to operator learning. First, although simulation and analysis can direct the system designer towards effective jamming techniques, the final optimization requires repetitive runs to home in on the best waveforms. This can give the operator an opportunity to observe the techniques many times, and try various means of countering them. Although an operator in a real situation would only see a technique once, the test operator has multiple opportunities to learn. If a minor cue in a technique can be learned, the remaining test runs can result in zero effectiveness. This can clearly skew test results in an unrealistic and unfavorable manner. Second, the statistical requirements to establish confidence in the test data require multiple runs of the final jamming techniques. This further extends the operator learning opportunities, but can also present a situation where the aircraft geometry is the same run after run. Operators learning the target aircraft location can further bias the test results against the EW system.

Operator learning can never be totally eliminated, but it can be minimized. The first step is to limit operator exposure during optimization tests. This can be accomplished by utilizing a limited subset of available techniques during the optimization phase, ideally the lower priority techniques. When the data testing begins, the operator will be faced with previously unseen techniques. To minimize operator learning during the data runs, techniques with some

randomness should be employed. For example, if using false targets, randomize the position of the real target from run to run. If using multiple techniques with equivalent effectiveness, also randomize selection of the technique for each engagement. Finally, plan the data test flights so that different aircraft geometries are interleaved rather than running one geometry repetitively.

4.3 Operator Observations

One of the data sources available during EW flight testing is the observation of the threat operators, both ground and air. However, if taken as gospel, these observations can create problems. Operator reports may favor their systems. The operators have pride in their systems and aircraft, and the adversarial nature of the tests stimulate operators competitiveness. Therefore, operator reports are susceptible to an unintentional bias against the EW system. Additionally, the best jamming techniques are surreptitious. The system may be indicating to the operator that all is well, when it really isn't. For example, a pilot may be maintaining a steady track, but it might not be on the real target. There are many examples of fighter pilots reporting "I had him all the way and could have foxed (fired a missile) at any time", when later data analysis indicated it was a side lobe lock that had the antenna pointing in the wrong direction, where a missile firing would only have resulted in a wasted missile.

The solution to these potential problems is threefold. First, verify and validate all operator observations during data analysis. If the data confirms the observation, the confidence is increased. If the data refutes the observation, this is also valuable information, since it can provide insight to how a real operator will interpret the jamming effects. Second, deploy test personnel to observe at radar sites. They can not only provide independent observations, but can also learn from watching the displays and the operator actions. For airborne threats, the cockpit displays should be videotaped, with contemporaneous comments from the pilot also recorded. Third, the test personnel should conduct thorough crew debriefs. Ask about specific cues that led to any observations. Get as much detail as possible to understand the operators thought processes in the face of the jamming.

4.4 Operator Cooperation

EW testing often uses US systems as surrogates for foreign threats. Generally this requires restricting the radar system operating modes which are beyond the real threat capability. This can tempt operators to sneak a peek at the forbidden settings. Being human, the operators are often both curious and competitive. They will sometimes try a restricted setting, especially if the jamming is successfully defeating the limited modes. If they do try, they often won't admit to it. This can corrupt optimization and/or data collection.

A solution that ERI has employed in the past with very good success is to dedicate one run per day for the radar operator. For that run he is allowed unrestricted free play for his radar. ERI programmed different techniques for him and provided assistance analyzing the data. This satisfied all operators curiosity and competitiveness, making it easy for them to stay within the restrictions for the rest of the test. This insured valid EW data collection, and provided the radar personnel additional useful data. It is a win-win approach that gets everyone on the same team.

Unfortunately, occasionally the competitive urge can go beyond normal behavior. ERI was involved in a helicopter EW test which successfully employed many of the operator learning defenses described previously. When the data runs started, the operators were caught by surprise and the EW system performed very effectively. Apparently the lead radar operator assumed nothing could beat the radar, because he called an immediate halt to the test so he could re-calibrate the radar. After calibration, the test resumed with the same good EW system performance. This was just too much for him. He opened one of the radar system drawers, and started adjusting the radar servo loop, while the jamming was present, dampening the response to the point where the EW system could no longer drive the radar off the helicopter. At that setting, the radar could not track anything but a slow moving helicopter and was clearly an egregious violation of fairness for the test. The Army project manager witnessed these actions first hand, and said to the radar operator "you can't do that." He replied, "Lady, it's my radar, I can do whatever I want." Fortunately that is a rare occurrence, but it highlights the extremes of human behavior that the competitive nature of EW can cause.

5.0 DATA ISSUES

EW tests tend to generate a lot of data. Very often, millisecond type events must be obtained from data streams running for minutes. The problems stem from the nature of the data - digital rather than analog, and the turnaround time required to reduce the data for analysis.

5.1 Analog vs. Digital

The preponderance of data generated in EW flight testing is digital. All EW systems are under computer control, many of them including distributed microprocessors. Therefore, virtually all of the data generated is digital. Analyzing digital data can be very time consuming. It is difficult to scan thousands of lines of data looking for correlated events without automated routines. The high sample rates are required to capture all the events, producing the volumes of data. Lower sampling rates could reduce the amount of data, but at the risk of missing significant events. Alternatively, analog data paints a picture of the events, enabling rapid insight into events. **Figure 5** illustrates the advantages of analog data for a quick "big picture" look over digital data.

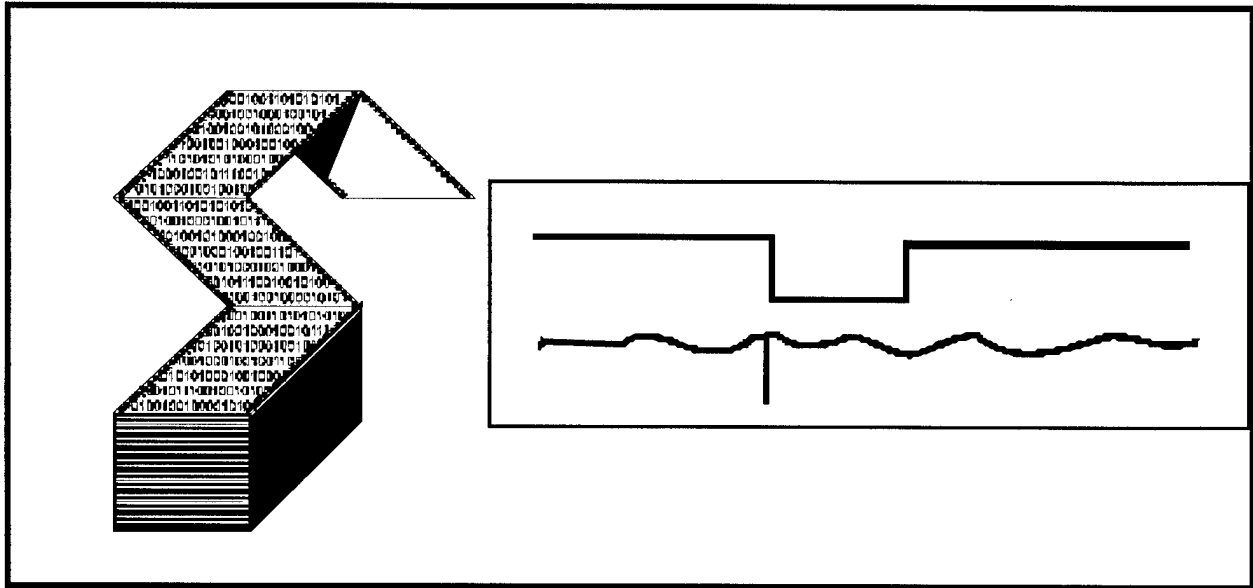

Figure 5 - Analog versus Digital Data

The primary solution obviously is to generate analog data. This can be done at the recording site, by adding analog recording channels to capture critical data such as received power level (envelope detector) and transmitted power for each jamming channel. Alternatively, this can be produced by post-processing, to generate analog reports from recorded digital data. Having key data in analog form can enable quick look analyses of entire runs in brief scans. The human eye and brain can process analog data virtually instantly. A secondary solution is to filter the digital data for volume reduction. Collect the data at the required high sampling rate, but print out only when selected parameters change. This will eliminate several hundred lines of identical data which must be carefully scanned to find a single parameter change which may be meaningful.

5.2 Turnaround Time

The high volume and complex nature of EW test data can result in long turnaround times. In the worst case, it can exceed the time between flights. During optimization or troubleshooting efforts, this can be a disaster. Data turnaround times can reach a week, while flights can be scheduled three times a week. It is difficult to plan Monday's flight when the previous data arrives Friday. ERI encountered exactly this situation during a B-52 EW test. Schedule demands drove the test to 3 flights a week, but the data reduction facility was working on a 6 day turnaround.

The ideal solution is to interleave threats on the schedule, so a given threat won't be repeated until after the previous data is available. However, this is often not practical. In that case, it becomes necessary to generate critical data products by hand from immediately available data. Examples include hand drawn strip charts from viewing cockpit videos, and hand drawn strip charts from unfiltered on-board digital printouts. These can be correlated via time, since all recordings include a common range clock, usually Greenwich (Zulu) time. Although this is not a replacement for end product data analysis, it can provide enough insights to make some educated assessments for the next flight.

This is exactly what ERI did when the B-52 test schedule got frantic. F-15 cockpit videos were run frame by frame, and significant events were recorded by hand. **Figure 6** illustrates the eclectic mix of technologies used to solve this problem.

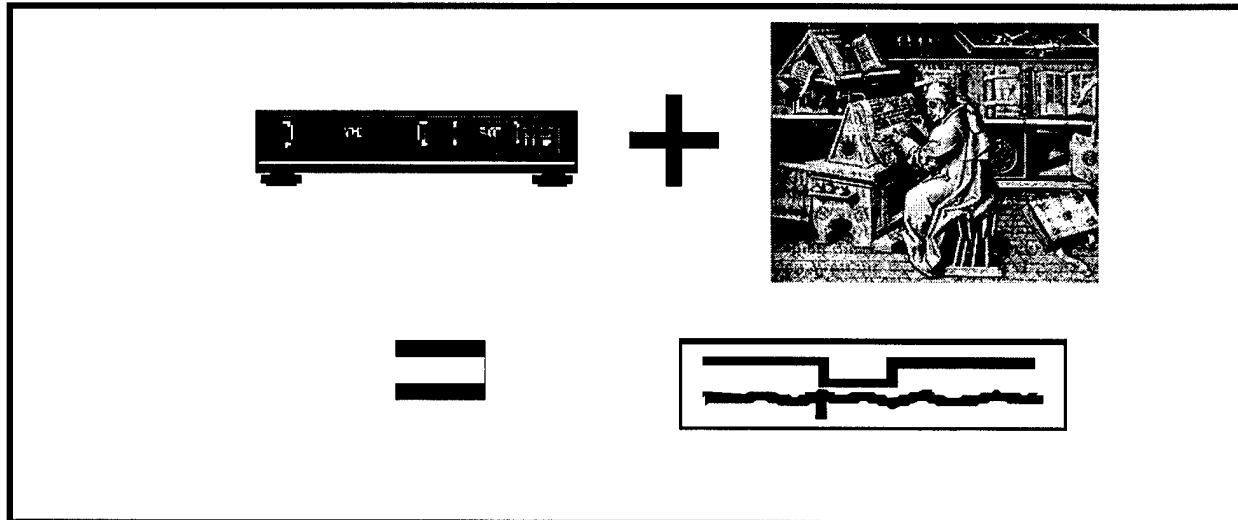

Figure 6 - Technologies employed for data turn around solution

The video radar data included changes in velocity, range, azimuth, or elevation. The digital system data recorded on the aircraft was printed by Boeing as soon as the aircraft landed and overnight expressed to the test range. The data volume had been reduced by the selective print out technique, and was analyzed for critical events. Finally, strip charts were manually created from the two data sources. The alignment of the data from the two sources was verified by correlation of the EW velocity jamming and the F-15 velocity readout. It provided enough information to make educated decisions for the successive flights, until the full data package could be reduced and analyzed.

6.0 SUMMARY

Electronic Warfare testing provides many challenges and is fraught with dangerous problems. Fortunately, many known problems can be anticipated and avoided. If a real estate agent's secret to housing is "Location, Location, Location," ERI's secret to EW testing is "Plan, Plan, Plan." Yet despite the best laid plans, there will be problems. One of the strangest of these involved a recent helicopter borne EW flight test at Eglin. A couple of weeks were lost due to an aircraft accident. The helicopter was hit while it was parked on the flight line - by a lawnmower! Even worse, the driver couldn't be arrested - he was already a prisoner at Eglin's Club Fed!

The bottom line is there will be problems, that is guaranteed. However, with foresight and planning, at least they won't be the same old familiar problems.

PLEASE CHECK THE APPROPRIATE BLOCK BELOW:

-AO# _____

_____ copies are being forwarded. Indicate whether Statement A, B, C, D, E, F, or X applies.

DISTRIBUTION STATEMENT A:
APPROVED FOR PUBLIC RELEASE: DISTRIBUTION IS UNLIMITED

DISTRIBUTION STATEMENT B:
DISTRIBUTION AUTHORIZED TO U.S. GOVERNMENT AGENCIES ONLY; (Indicate Reason and Date). OTHER REQUESTS FOR THIS DOCUMENT SHALL BE REFERRED TO (Indicate Controlling DoD Office).

DISTRIBUTION STATEMENT C:
DISTRIBUTION AUTHORIZED TO U.S. GOVERNMENT AGENCIES AND THEIR CONTRACTORS; (Indicate Reason and Date). OTHER REQUESTS FOR THIS DOCUMENT SHALL BE REFERRED TO (Indicate Controlling DoD Office).

DISTRIBUTION STATEMENT D:
DISTRIBUTION AUTHORIZED TO DoD AND U.S. DoD CONTRACTORS ONLY; (Indicate Reason and Date). OTHER REQUESTS SHALL BE REFERRED TO (Indicate Controlling DoD Office).

DISTRIBUTION STATEMENT E:
DISTRIBUTION AUTHORIZED TO DoD COMPONENTS ONLY; (Indicate Reason and Date). OTHER REQUESTS SHALL BE REFERRED TO (Indicate Controlling DoD Office).

DISTRIBUTION STATEMENT F:
FURTHER DISSEMINATION ONLY AS DIRECTED BY (Indicate Controlling DoD Office and Date) or HIGHER DoD AUTHORITY.

DISTRIBUTION STATEMENT X:
DISTRIBUTION AUTHORIZED TO U.S. GOVERNMENT AGENCIES AND PRIVATE INDIVIDUALS OR ENTERPRISES ELIGIBLE TO OBTAIN EXPORT-CONTROLLED TECHNICAL DATA IN ACCORDANCE WITH DoD DIRECTIVE 5230.25. WITHHOLDING OF UNCLASSIFIED TECHNICAL DATA FROM PUBLIC DISCLOSURE. 6 Nov 1984 (Indicate date of determination). CONTROLLING DoD OFFICE IS (Indicate Controlling DoD Office).

This document was previously forwarded to DTIC on _____ (date) and the AD number is _____.

In accordance with provisions of DoD instructions, the document requested is not supplied because:

It will be published at a later date. (Enter approximate date, if known).

Other. (Give Reason)

DoD Directive 5230.24, "Distribution Statements on Technical Documents," 18 Mar 87, contains seven distribution statements, as described briefly above. Technical Documents must be assigned distribution statements.

Tom Mirnich

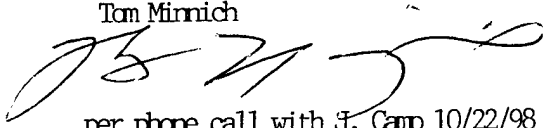

per phone call with J. Camp 10/22/98

Authorized Signature/Date

AFRL/FSD
2241 Avionic Circle
Wright-Patterson AFB, OH 45433-7318

John Camp
Print or Type Name

937 255-2164 3562

Telephone Number