



DOCUMENT 316-98

LASER RANGE SAFETY

WHITE SANDS MISSILE RANGE
KWAJALEIN MISSILE RANGE
YUMA PROVING GROUND
DUGWAY PROVING GROUND
ABERDEEN TEST CENTER
NATIONAL TRAINING CENTER

DTIC QUALITY INSPECTED 2

ATLANTIC FLEET WEAPONS TRAINING FACILITY
NAVAL AIR WARFARE CENTER WEAPONS DIVISION
NAVAL AIR WARFARE CENTER AIRCRAFT DIVISION
NAVAL UNDERSEA WARFARE CENTER DIVISION, NEWPORT
PACIFIC MISSILE RANGE FACILITY
NAVAL UNDERSEA WARFARE CENTER DIVISION, KEYPORT

30TH SPACE WING
45TH SPACE WING
AIR FORCE FLIGHT TEST CENTER
AIR FORCE DEVELOPMENT TEST CENTER
AIR WARFARE CENTER
ARNOLD ENGINEERING DEVELOPMENT CENTER
GOLDWATER RANGE
UTAH TEST AND TRAINING RANGE

DISTRIBUTION A: APPROVED FOR PUBLIC RELEASE;
DISTRIBUTION IS UNLIMITED

19981027 028

REPORT DOCUMENTATION PAGE

Form Approved
OMB No. 0704-0188

Public reporting burden for this collection of information is estimated to average 1 hour per response, including the time for reviewing instructions, searching existing data sources, gathering and maintaining the data needed, and completing and reviewing the collection of information. Send comments regarding this burden estimate or any other aspect of this collection of information, including suggestions for reducing this burden, to Washington Headquarters Services, Directorate for Information Operations and Reports, 1215 Jefferson Davis Highway, Suite 1204, Arlington, VA 22202-4302, and to the Office of Management and Budget, Paperwork Reduction Project (0704-0188), Washington, DC 20503.

1. AGENCY USE ONLY <i>(Leave blank)</i>	2. REPORT DATE OCTOBER 1998	3. REPORT TYPE AND DATES COVERED	
4. TITLE AND SUBTITLE LASER RANGE SAFETY		5. FUNDING NUMBERS	
6. AUTHOR(S)		8. PERFORMING ORGANIZATION REPORT NUMBER RCC DOCUMENT 316-98	
7. PERFORMING ORGANIZATION NAME(S) AND ADDRESS(ES) RANGE SAFETY GROUP RANGE COMMANDERS COUNCIL WHITE SANDS MISSILE RANGE, NM 88002-5110		10. SPONSORING / MONITORING AGENCY REPORT NUMBER SAME AS BLOCK 8	
9. SPONSORING / MONITORING AGENCY NAME(S) AND ADDRESS(ES) STEWs-RCC RANGE COMMANDERS COUNCIL WHITE SANDS MISSILE RANGE, NM 88002-5110		11. SUPPLEMENTARY NOTES SUPERSEDES RCC DOCUMENT 316-91, AD A243606	
12a. DISTRIBUTION / AVAILABILITY STATEMENT APPROVED FOR PUBLIC RELEASE; DISTRIBUTION UNLIMITED		12b. DISTRIBUTION CODE	
13. ABSTRACT <i>(Maximum 200 words)</i> This handbook provides uniform evaluation guidance for the safe use of military lasers and laser systems on worldwide Range Commanders Council (RCC) military reservations or military controlled areas. Each military service has previously established normal procedures for approving laser ranges. This guidance is intended to supplement these procedures. It does not replace those procedures or release individuals from compliance with the requirements of their particular service.			
14. SUBJECT TERMS laser, laser safety		15. NUMBER OF PAGES 173	
17. SECURITY CLASSIFICATION OF REPORT unclassified		16. PRICE CODE	
18. SECURITY CLASSIFICATION OF THIS PAGE unclassified	19. SECURITY CLASSIFICATION OF ABSTRACT unclassified	20. LIMITATION OF ABSTRACT none	

DOCUMENT 316-98

LASER RANGE SAFETY

OCTOBER 1998

Prepared by

**Range Safety Group
Laser Safety Committee
Range Commanders Council**

Published by

**Secretariat
Range Commanders Council
White Sands Missile Range
New Mexico 88002-5110**

TABLE OF CONTENTS

	<u>PAGE</u>
CHAPTER 1 – GENERAL.....	1-1
1.1 Scope.....	1-1
1.2 Application.....	1-1
1.3 Exclusions.....	1-2
1.4 High Energy Systems.....	1-2
1.5 Broad Beam Lasers.....	1-2
1.6 Force-On-Force Exercises.....	1-2
1.7 Content.....	1-3
CHAPTER 2 - APPLICABLE DOCUMENTS.....	2-1
2.1 General.....	2-1
2.2 Government Documents.....	2-1
2.2.1 Standards.....	2-1
2.2.2 Other Government Publications.....	2-1
2.3 Non-Government Publications.....	2-3
2.4 Order of Precedence.....	2-4
CHAPTER 3 - DEFINITIONS.....	3-1
CHAPTER 4 - GENERAL RANGE CONTROL PHILOSOPHY.....	4-1
4.1 General Policy.....	4-1
4.2 Recommended Targets.....	4-3
4.3 Beam Control.....	4-3
4.4 Specular Reflectors.....	4-3
4.5 Hazards.....	4-3
4.6 Unprotected Personnel.....	4-4
4.7 Warning Signs.....	4-4
4.8 Personnel Protection.....	4-6
4.9 Magnifying Optics.....	4-6
4.10 Night Vision Goggles/Devices.....	4-6
4.11 Specific Guidelines.....	4-7
4.12 Laser Pre-Firing and Post-Firing Restrictions.....	4-10
4.13 Stationary Continuously Operating Lasers.....	4-10
4.14 Tactics.....	4-11
4.14.1 Ground Laser Designators.....	4-11
4.14.2 Airborne Wingman Laser.....	4-12

CHAPTER 5 - RANGE EVALUATION PLANNING REQUIREMENTS	5-1
5.1 Background	5-1
5.2 Laser User	5-1
5.3 Range Operator	5-1
5.4 Range Evaluator	5-2
CHAPTER 6 - RANGE EVALUATION REQUIREMENTS	6-1
6.1 Evaluation Sequence	6-1
6.1.1 Laser	6-1
6.1.1.1 Maximum Permissible Exposure (MPE) Limits	6-1
6.1.1.2 Laser Classifications	6-1
6.1.1.3 Nominal Ocular Hazard Distances	6-1
6.1.1.4 Reflections	6-1
6.1.1.4.1 Specular Reflections	6-1
6.1.1.4.2 Diffuse Reflections	6-1
6.1.1.5 Optical Density	6-3
6.1.1.6 Optical Viewing	6-3
6.1.1.7 Atmospheric Attenuation	6-3
6.1.1.8 Laser Platform Stability	6-3
6.1.2 Range	6-3
6.1.2.1 Range Map	6-4
6.1.2.2 Topographic Map	6-4
6.1.2.3 Airspace Map	6-4
6.1.3 Target and Target Area	6-4
6.1.3.1 Optimum Target	6-4
6.1.3.2 Size and Location	6-5
6.1.3.3 Separate Target	6-5
6.1.4 Mission	6-5
6.1.4.1 Air-to-Ground	6-5
6.1.4.2 Ground-to-Ground	6-6
6.1.4.3 Ship-to-Target	6-6
6.1.5 Laser Surface Danger Zone	6-6
6.2 Target and Target Area Condition	6-6
6.3 System Performance	6-6
6.3.1 Buffer Zones	6-6
6.3.2 Laser Variety	6-7
6.4 Laser Surface Danger Zone	6-7
6.4.4.1 Existing Surface Danger Zones	6-10
6.4.4.2 Distance of the Laser Surface Danger Zone	6-10
6.4.4.3 Buffer Zones	6-13
6.5 Range Facilities Evaluation	6-13
6.5.1 Range Location and Access	6-13
6.5.2 Target Types	6-13
6.5.3 Terrain Features	6-14
6.5.4 Access Control	6-14
6.5.5 Operations Over Water	6-14

6.6	Visual Survey.....	6-16
6.7	Laser Parameters.....	6-16
6.8	Laser Footprint.....	6-17
6.8.1	Buffer Angle.....	6-17
6.8.2	Footprint Size.....	6-17
6.9	Other Considerations.....	6-18
6.9.1	Moving Target with Lasers.....	6-18
6.9.2	Operating Outside of Controlled Area.....	6-20
6.10	Range Control Procedures and Recommendations.....	6-20
6.10.1	Target Areas.....	6-20
6.10.2	Sanitized Ranges.....	6-20
6.10.3	Laser Operation.....	6-20
6.10.4	Unprotected Personnel.....	6-20
6.10.5	Warning Signs.....	6-20
6.10.6	Eye Wear.....	6-20
6.10.7	Optical Devices.....	6-21
6.10.8	Range Access Restrictions.....	6-21
6.10.9	Laser Demonstrations.....	6-21
CHAPTER 7 - USER LEVEL LASER INSTRUCTIONS.....		7-1
7.1	Instruction.....	7-1
7.2	Directives.....	7-1
7.3	Standard Operating Procedures.....	7-1
7.4	Safety Briefing.....	7-1
7.5	Protective Equipment.....	7-2
7.6	Systems Briefings.....	7-2

APPENDIXES

PAGE

APPENDIX A - LASER SAFETY INFORMATION FOR FIRE CONTROL LASER SYSTEMS A-1

1.0 Scope A-2
2.0 Fire Control Laser Safety Features..... A-2
2.1 Ruby LRFs.. A-2
2.2 Distance S..... A-2
2.3 Current Laser Safety Summary.. A-2
2.4 Buffer Zones..... A-12
2.5 Eye Protection. A-12
2.6 Fielded Laser System Descriptions. A-12
2.7 Inactive Lasers Descriptions and Associated Systems..... A-15

APPENDIX B - MULTIPLE INTEGRATED LASER ENGAGEMENT SYSTEM (MILES) OPTICAL SAFETY SUMMARYB-1

1.0 ScopeB-2
2.0 Applicable DocumentsB-2
3.0 Miles.....B-2
4.0 Schwartz Electro-Optic Controller GunB-2

APPENDIX C - AIR TO GROUND ENGAGEMENT SYSTEM/AIR DEFENSE, LASER AIR TO AIR GUNNERY SYSTEMS, PRECISION GUNNERY TRAINING SYSTEM, AND AN/GTV-1 SAFETY SUMMARYC-1

1.0 ScopeC-2
2.0 Applicable DocumentsC-2
3.0 Safety SummaryC-2

APPENDIX D - SAMPLE CONTENT FOR LASER SAFETY SOP FOR TRAINING WITH PORTABLE FIRE CONTROL LASERS..... D-1

1.0 Scope D-2
2.0 Warning..... D-2

APPENDIX E- EQUATIONS FOR LASER HAZARD EVALUATIONE-1

1.0 ScopeE-2
2.0 Applicable DocumentsE-2
3.0 Equation ApplicationsE-2
3.1 Sloping Ranges.....E-2
3.2 Shipboard Laser System.....E-2
3.3 Hazard Evaluation..E-3
3.3.1 Buffered Footprint Definition.E-3
3.3.2 Hazard Evaluation Without Specular Reflections.....E-3

3.3.2.1	Single Laser Aircraft Heading.....	E-3
3.3.2.2	Multiple Laser Aircraft Headings.....	E-3
3.3.2.3	Level Ground Examples.....	E-3
3.3.2.3.1	Example 1 (Level Ground).....	E-3
3.3.2.3.2	Example 2 (Level Ground).....	E-11
3.3.2.4	Unlevel Terrain.....	E-11
3.3.2.4.1	Target on Rising Terrain Or Hills Behind Target	E-11
3.3.2.4.2	Falling Terrain in Target Area or Hills in Foreground.....	E-11
3.3.2.4.2.1	Foreground Distances.....	E-11
3.3.2.4.2.1	Distance Beyond Target	E-11
3.3.3	Specular Reflections.....	E-11
3.3.4	Aircrew	E-14
3.3.5	Ground Personnel, Shipboard Personnel, Other Aircraft, and Surrounding Community.....	E-14
3.3.6	Hazard Distances From Various Reflective Surfaces	E-14
3.4	Footprint Determinations	E-14
3.4.1	Ground Based Lasers.....	E-14
3.4.1.1	Vertical Buffer Far Boundary.....	E-14
3.4.1.2	Vertical Buffer Near Boundary	E-18
3.4.1.3	Horizontal Buffer	E-18
3.4.2	Airborne Laser with Target on Level Ground.....	E-19
3.4.2.1	Aircraft Minimum Altitude	E-19
3.4.2.2	Left and Right Hand LSDZ	E-22
3.4.2.3	Airborne Laser with Target on Sloping Ground	E-22
3.4.2.3.1	Buffered Footprint.....	E-22
3.4.2.3.2	For Far Target.....	E-25
3.4.2.3.3	For Near Target	E-25
3.4.2.3.4	Left and Right Hand LSDZ	E-25
APPENDIX F - DOD LASER RANGE SURVEY CHECKLISTS.....		F-1
1.0	Scope	F-2
2.0	Checklists	F-2
APPENDIX G - SPECULAR REFLECTION.....		G-1
1.0	Scope	G-2
2.0	Applicable Documents	G-2
3.0	Specular Reflection Characteristics.....	G-2
3.1	Flat Reflectors	G-2
3.2	Hazardous Ranges of Reflected Laser Beam	G-2
3.2.1	Reflection from Reflector Larger Than Cross Section of Incident Laser Beam.....	G-3
3.2.2	Reflection from Reflector Smaller than Incident Laser Beam Cross Section.....	G-8

APPENDIX H - SEPARATE TARGET (SEPTAR) AND SHIP'S TOWED TARGET OPERATIONS H-2

1.0 Scope H-2
2.0 Applicable Documents H-2
3.0 Septar Operations H-2
4.0 Ship's Towed Target Operations H-9

APPENDIX I - SATELLITE SAFETY PROCEDURES I-1

1.0 Scope I-2
2.0 References I-2
3.0 Definitions For Space-Directed Laser Emissions..... I-2
4.0 Applicability I-4
5.0 Concept Of Operations I-4
6.0 JCCDOA Responsibilities I-5
7.0 Laser Facility Responsibilities I-6

FIGURES

PAGE

4-1	Direct intrabeam viewing	4-2
4-2	Reflected intrabeam viewing.....	4-2
4-3	Example: warning sign.....	4-5
4-4	Sample safety exclusion cone for ground laser designator	4-12
4-5	Sample side view of safety exclusion volumes for ground laser designator	4-14
4-6	Sample plan view of safety exclusion cones to prevent homing on laser designator aircraft during continuous laser designation.....	4-14
4-7	Sample vertical view of safety exclusion cones to prevent homing on continuous laser designator aircraft	4-15
4-8	Sample delayed laser designation safety exclusion cone, vertical view	4-16
4-9	Generalized concept of risk variables related to laser target designator and laser seeker field of view	4-17
6-1	Diffuse reflection and specular reflection	6-2
6-2	Laser surface danger zone (SDZ).....	6-8
6-3	LSDZ without and with natural backstop.....	6-9
6-4	Example laser range danger fan/laser surface danger zone.....	6-11
6-5	Vertical buffer zone.....	6-12
6-6	Effects of backstops.....	6-13
6-7	Example of airborne beam reflection	6-15
6-8	Examples of the use of natural backstops, buffer zones, and restricted air space.....	6-19
6-9	Supervised laser demonstration for military training. (modified from FIGURE 2D, ANSI Z136.1).....	6-22
E-1	Laser footprint with single target - side view	E-4
E-2	Laser footprint with multiple targets - side view.....	E-4
E-3	Laser footprint top view	E-4
E-4	LSDZ - attack bearing 90°.....	E-10
E-5	LSDZ - attack bearing 70 to 110°	E-10
E-6	LSDZ - attack from any direction	E-10
E-7	LSDZ with rising terrain	E-12
E-8	Use of natural backstops to control laser beam.....	E-12
E-9	Insufficient backstop to control laser beam.....	E-12
E-10	LSDZ with terrain sloping down. Range less than NOHD	E-13
E-11	LSDZ with terrain sloping down. Range greater than NOHD	E-13
E-12	Reflections from still water with LDZ	E-13
E-13	Example of airborne laser beam reflection.....	E-15
E-14	Potential exposure modes.....	E-16
E-15	Reflections from flat specular surface - side view	E-16
E-16	Reflections from flat specular surface - top view.....	E-16
E-17	Vertical buffer and LSDZ geometry.....	E-17
E-18	Calculation of available buffer versus allowed buffer	E-20
E-19	Airborne laser buffer geometry - level ground.....	E-21
E-20	Example laser aircraft flight profile	E-23
E-21	Laser target on sloping terrain.....	E-24
G-1	LSDZ with specular reflections from standing still water.....	G-5

G-2	LSDZ with specular reflective target - side view	G-5
G-3	Specular reflectance from both surfaces of plate glass (index of refraction = 1.5)	G-6
G-4	Specular reflectance from sea water (index of refraction = 1.378)	G-7
G-5	Specular reflectance from fresh water (index of refraction =1.33)	G-8
H-1	SEPTAR operations area and buffer zone	H-3
H-2	Zones relative to towing ship's heading in which laser operations are permitted for A-6E TRAM, OV-10D NOS, F111-Pave Tack, and Pave Spike	H-10

TABLES

PAGE

6-1	Typical reflective surfaces.....	6-3
A-1	NOHD and range safety information for fielded military laser systems	A-3
A-2	NOHD and range safety information for commercial off-the-shelf (COTS) military lasers	A-8
A-3	Eye protection requirements for fielded lasers	A-9
A-4	Eye protection requirements for COTS military lasers	A-11
B-1	NOHD for miles and other training lasers	B-3
C-1	Cautionary distances for eye exposure to the AGES/AD, LATAGS, PGTS, TWGSS/PGS, JAVELIN, ISMT/IST, and AN/GVT-1.....	C-4
E-1	Laser footprint table for: pave spike (using vacuum NOHD).....	E-5
E-2	Laser footprint table for: pave spike (including atmospheric attenuation for lasing from altitudes below 1 km MSL only).....	E-6
E-3	Laser footprint table for: pave tack (using vacuum NOHD)	E-7
E-4	Laser footprint table for: pave tack (including atmospheric attenuation for lasing from altitudes below 1 km MSL only).....	E-8
E-5	Laser footprint table for: any laser system with beam divergence 0.5 MRAD	E-9
G-1	Reflectivity of glass at various angles of incidence.....	G-10
G-2	Reflectivity of fresh water at various angles of incidence	G-10
G-3	Reflectivity of sea water at various angles of incidence	G-11
G-4	Reflectivity of shiny metal	G-11
H-1	Flight profile against SEPTAR. One NMI buffer zone around one nautical mile operation area - 0 degree to 360 degrees	H-4
H-2	Flight profile against SEPTAR. Two NMI buffer zone around one nautical mile operation area - 0 degree to 360 degrees	H-5
H-3	Flight profile against SEPTAR. Three NMI buffer zone around one nautical mile operation area - 0 degree to 360 degrees	H-6
H-4	Flight profile against SEPTAR. Four NMI buffer zone around one nautical mile operation area - 0 degree to 360 degrees	H-7
H-5	Flight profile against SEPTAR. Five NMI buffer zone around one nautical mile operation area - 0 to 360°.....	H-8

FOREWORD

This document, Laser Range Safety, is published with the approval of the Range Commanders Council. The contents of this handbook are intended to serve as a guide to the safe use of lasers and laser systems used on military reservations and in military controlled areas. This edition of the 316 has been extensively revised from the previous issue.

Subject term (keyword) listing

Apertures	Hazard	Zone Laser Radiation	Transmittance
Attenuation	Lasers	Optical Density	Ultraviolet Radiation
Exclusion Zones	Laser Radiation	Radiant Energy	Wavelength

This document is applicable to all Department of Defense (DOD) member ranges, operational test facilities where lasers are used, and all DOD laser operations conducted on non-DOD controlled ranges or test facilities. The guidance in this document does not replace other procedures or release individuals from compliance with the requirements of their particular service.

Certain provisions of this handbook are the subject of international standardization agreement, STANAG 3606, Evaluation and Control of Laser Hazards. When any amendment, revision, or cancellation of this handbook is proposed which is inconsistent with the international agreement concerned, the preparing activity will take appropriate action through international standardization channels, including departmental standardization offices, to change the agreement or make other appropriate accommodations.

A companion document, issued under the authority of DOD, is DOD Instruction 6055, Personnel Protection Policy Exposure to Laser Radiation. Its purpose is to provide uniform guidance for the safe use of military lasers and laser systems on DOD military reservations or military controlled areas worldwide. Copies of this document may be obtained through DOD publication channels. Other federal agencies and the public may obtain copies from:

Office of the Assistant Secretary of Defense
Environment and Safety
Washington, DC 203330-1000

Copies of Laser Range Safety may be obtained from the

Secretariat
Range Commanders Council
ATTN: STEWS-RCC
White Sands Missile Range, New Mexico 88002-5110

The Range Commanders Council point of contact is

Naval Air Warfare Center Weapons Division
Code 870000E Mr. George Wadley
Point Mugu, California 93042
DSN 351-0041
Commercial (805) 989-0041

CHAPTER 1

GENERAL

1.1 Scope

This handbook provides uniform evaluation guidance for the safe use of military lasers and laser systems on worldwide Range Commanders Council (RCC) military reservations or military controlled areas. Each military service has previously established normal procedures for approving laser ranges. This guidance is intended to supplement these procedures. It does not replace those procedures or release individuals from compliance with the requirements of their particular service. The authority for guidance is the Laser System Safety Working Group (LSSWG) established by DODI 5000.1 and Range Commanders Council. Guidance for lasers not addressed here should be obtained from the LSSWG through respective service health and safety organizations listed in Paragraph 1.2.

1.2 Application

This handbook applies to:

- All RCC ranges or operational test facilities where lasers are used and all RCC laser operations conducted on non-DOD controlled ranges or test facilities.
- Laser systems which have been evaluated by the DOD Laser Safety Review Board health and safety specialists for your respective service.

US Army Center for Health Promotion and Preventive Medicine
ATTN: MCHB-DC-OLO
Aberdeen Proving Ground, Maryland 21010-5422
DSN 584-3932/2331, Commercial (301) 671-3932

Space and Naval Warfare Systems Command (Code 00F)
2451 Crystal Drive
Arlington, Virginia 22245-5200
DSN 332-7235/73, Commercial (703) 602-7235

Armstrong Laboratory
Health Physics
Optical Radiation Division
Brooks AFB, Texas 78235-5501
DSN 240-4784, Commercial (210) 536-3625

- Outdoor laser use.
- Single-sided laser exercises.
- Fixed and rotary wing airborne laser platforms as well as ground- and ship-mounted laser systems.

1.3 Exclusions

This handbook does not apply to indoor use, for example, laboratory laser repair depots or industrial laser facilities because of the unique control measures required, industrial and construction lasers such as those used for surveying; and new technology laser applications.

1.4 High Energy Systems

High energy laser systems (lasers capable of cutting material or burning standard target material) require unique control measures. Use of these lasers must be approved by the local Laser Safety Officer (LSO) in coordination with the specialists designated in paragraph 1.2.

1.5 Broad Beam Lasers

Lasers with broad beam or autonomous scanning systems that are not directly under the operator's control may require additional evaluation assistance from the organizations listed in paragraph 1.2.

1.6 Force-On-Force Exercises

Force-on-force exercises using lasers and laser devices are special cases requiring additional controls. Exceptions are training lasers such as the Multiple Integrated Laser Engagement System (MILES) which is addressed in Appendix B. These force-on-force lasers must be addressed on an individual basis by the local LSO with assistance from the service component safety and health specialist designated in paragraph 1.2.

1.7 Content

This handbook contains appendixes, which give general and detailed policies to be followed in evaluating and recommending laser range safety procedures. Appendix A provides safety hazard control data for specific laser systems evaluated by each of the service safety specialists. Appendix B furnishes safety information on lasers used for scoring tactical exercises. Appendix C summarizes safety data for gunnery training systems and simulators. Appendix D is a sample of a laser safety standard operating procedure (SOP). Appendix E describes the equations used to determine Laser Surface Danger Zones (LSDZ)/Nominal Hazard Zones (NHZ). Appendix F contains checklists to be used for the laser safety pre-survey, the site survey, and the laser range safety evaluation reports. Appendix G discusses methods for evaluating hazards from specular reflections of the laser beam. Appendix H deals with safety policy for at-sea operations against ship towed targets and separate targets (SEPTAR). Appendix I addresses procedures for obtaining approval from the Space Command Control Center for Space Directed Emissions.

CHAPTER 2

APPLICABLE DOCUMENTS

2.1 General

The documents listed below are referenced in Chapters 3, 4, and 5 of this standard. This list does not include documents cited in other sections of this document or recommended for additional information or as examples. While every effort has been made to ensure the completeness of this list, document users are cautioned that they must meet all specified requirements of the documents cited in Chapters 3, 4, and 5, whether or not they are listed below.

2.2 Government Documents

2.2.1 Standards. Unless otherwise specified, the following documents are those listed in the latest issue of the Department of Defense Index of Specifications and Standards (DODISS) and supplement cited in the solicitation and form a part of this handbook to the extent specified herein.

MILITARY STANDARDS

MIL-STD-1425A	Safety Design Requirements For Military Lasers And Associated Support Equipment
---------------	--

NATO STANDARDIZATION AGREEMENTS

STANAG 3606	Evaluation and Control of Laser Hazards
-------------	---

Unless otherwise indicated, copies of the above standards are available from the Standardization Document Order Desk, 700 Robbins Avenue, Building 4D, Philadelphia, Pennsylvania 19111-5094.

2.2.2 Other Government Publications. This standard supplements, but does not supersede the regulations for each Service. All offices responsible for laser safety will have a copy of the references applicable to their Service. The following government publications are referenced in this standard:

Joint Chiefs of Staff

JCS PUB 3-09.1 (JLASER)	Joint Laser Designation Procedures
-------------------------	------------------------------------

Department of Defense

DOD Instruction 6055.11

Protection of DOD Personnel from Exposure to Radio frequency Radiation and Military Exempt Lasers, 21 Feb 1995

DOD Directive 3200.22
RCC Document
316-91

Operation on National Ranges and Test Facilities
Laser Range Safety, Range Safety Group,
DOD Range Commanders Council

US Army

TB MED 524

Control of Hazards to Health from Laser Radiation

DAPM 385-63/MCO
P3570.1
AR 40-46

Policies and Procedures for Firing Ammunition for Training, Target Practice and Combat
Control of Health Hazards from Lasers and Other High Intensity Light Sources

AR 385-30
AMCR 385-29
AR 40-5

Safety Color Code Markings and Signs
Safety-Laser Safety
Preventive Medicine

US Navy

SECNAV Instruction
5100.14B
SPAWAR Instruction
5100.12B
MCO 5104.1
NSWCDD/MP-94/289

Exemption of Military Laser Products

BUMED Instruction
6470.2A
EO410-BA-GYD-010
MCO P3570.1

Navy Laser Hazards Prevention Program

Marine Corps Laser Hazards Control Program
Descriptions of Navy and Marine Corps Laser Systems, by Sheldon Zimmerman, September 1995
Laser Radiation Health Hazards

Technical Manual, Laser Safety
Policies and Procedures for Firing Ammunition for Training, Target Practice and Combat

US Air Force

AFOSH Standard 161-10
USAFOEHL Report
AL-TR-1991-0112
USAFOEHL Report
87-091RC0111GLA
AFI 13-212

Health Hazards Control for Laser Radiation
Base-Level Management of Laser Radiation
Protection Program
Laser Range Evaluation Guide For
Bioenvironmental Engineers
Weapons Range Management

CODE OF FEDERAL REGULATIONS (CFR)

21 CFR Part 1040
Products

Performance Standards For Light-Emitting

OCCUPATIONAL SAFETY AND HEALTH ADMINISTRATION (OSHA)

OSHA Publication 8-1.7
Assessment

Guidelines for Laser Safety and Hazard

FEDERAL AVIATION ADMINISTRATION (FAA)

FAA 7930.2B

Notices To Airmen (NOTAM)

Copies of specifications, standards, handbooks, drawings, publications, and other government documents required by contractors in connection with specific acquisition functions should be obtained from the contracting activity or as directed by the contracting officer.

2.3 Non-Government Publications

The following document applies to the extent specified in this document. Unless otherwise specified, documents which are DOD adopted are those listed in the latest issue of the DODISS cited in the solicitation. Documents not listed in the DODISS are the issues of the documents cited in the solicitation.

AMERICAN NATIONAL STANDARDS INSTITUTE (ANSI)

ANSI Z136.1

Safe Use of Lasers

Copies of this document may be obtained through DOD publication channels for government activities. For all others, requests for copies should be addressed to American National Standards Institute (ANSI), 1430 Broadway, New York, New York.

2.4 Order of Precedence

In the event of a conflict between the text of this standard and the references cited, the conflict will be referred to the military service specialists referenced in Chapter 1, Paragraph 1.2 of this document who have jurisdiction over the laser range. Nothing in this standard shall supersede applicable laws and regulations unless a specific exemption has been obtained.

CHAPTER 3

DEFINITIONS

The following definitions and terms are used in this handbook. For other definitions associated with laser safety, refer to ANSI Z136.1, Safe Use of Lasers.

Aircraft Exclusion Zone. A cone around the laser line-of-sight (LOS) that is 20 times the buffer angle. Laser operations must stop when another aircraft enters this zone.

Aperture. Any opening in the protective housing, shielding, or other enclosure of a laser product through which laser or collateral radiation is emitted, thereby, allowing human exposure to such radiation.

Attenuation. The decrease in the energy of any optical radiation beam as it passes through an absorbing or scattering medium or both.

Beam Divergence. The full angle width of the laser beam measured between the two points at which laser radiant exposure or irradiance in the laser beam is equal to $1/e$ (36.8 percent) of the maximum value.

Buffer Angle. The angle about the laser's LOS with apex at the laser aperture that is used to determine the buffer zone. As a minimum, it is typically set to five times the demonstrated pointing accuracy of the system plus the beam divergence. (Buffer angles for several lasers are assigned in Table A-1.)

Buffer Zone. A conical volume centered on the laser's LOS with its apex at the aperture of the laser, within which the beam will be contained with a high degree of certainty. The buffer zone is determined by the buffer angle.

Closed Installation. Any location where laser systems and products are used that will be closed or opaque to unprotected personnel during laser operations.

Collateral Radiation. Extraneous radiation such as secondary beams from optics, flash lamp light, radio frequency radiation, and x-rays that is not the intended laser beam as a result of the operation of the product or any of its components. System indicator lights would not normally be considered sources of collateral radiation.

Continuous Wave. The output of a laser that provides a steady or continuous output power rather than a pulsed output. A laser that emits a continuous output in excess of or equal to 0.25 seconds is a continuous wave laser.

Controlled Area. An area where the occupancy and activity of personnel within is subject to control and supervision for the purpose of protection from radiation hazards.

Diffuse Reflection. Reflection from a surface in which the beam is scattered in all directions, for example, a reflection from a rough surface. An ideal diffuse surface in which reflected brightness is independent of the viewing angle is called a Lambertian surface.

Electromagnetic Radiation. The propagation of energy consisting of alternating electric and magnetic fields which travel through space at the velocity of light and includes light, radio frequency radiation, and microwaves.

Exempted Lasers. Military lasers exempted from 21 CFR 1040, Performance Standards for Light-Emitting Products, where compliance would hinder mission fulfillment during actual combat or combat training operations or when the exemption is deemed necessary in the interest of national security. These lasers shall comply with MIL-STD-1425, Safety Design Requirements for Military Lasers and Associated Support Equipment. See DODI 6050.11.

Field of Detection. A volume of space within which a laser detecting system, for example, laser-guided munition, laser spot tracker, or night vision goggles (NVG), may acquire a laser designated target.

High Energy Laser. All class 4 lasers with power of at least 20 kilowatts for more than 1.5 seconds or energy of at least 30 kilojoules for less than 1.5 seconds.

Infrared Radiation (IR). Electromagnetic radiation with wavelengths within the range of 700 nanometers (nm) to 1000 micrometers (μm). This region is often divided into three spectral bands by wavelength: IR-A (700 nm to 1400 nm), IR-B (1400 nm to 3000 nm), and IR-C (3 nm to 1000 μm). IR-A is sometimes called near-infrared.

Irradiance (E). Measure of radiant power in watts per square centimeter.

Joule. A unit of energy, used principally for pulsed lasers, equal to 1 watt-second or 0.239 calories (cal).

Laser. Any device that can produce or amplify optical radiation primarily by the process of controlled stimulated emission. A laser may emit electromagnetic radiation from the ultraviolet portion of the spectrum through the infrared portion. An acronym for Light Amplification by Stimulated Emission of Radiation.

Laser Controlled Area. Any area that contains one or more lasers where the activity of personnel is subject to control and supervision for the protection from radiation hazards associated with laser operation.

Laser Footprint. The projection of the laser beam and buffer zone on the ground or target area. The laser footprint may be part of the laser surface danger zone if the laser footprint lies within the nominal ocular hazard distance (NOHD) of the laser.

Laser Radiation. Coherent electromagnetic radiation produced as a result of controlled stimulated emission within the spectral range of 200 nm to 1000 μm .

Laser Safety Officer (LSO)/Laser System Safety Officer (LSSO). At a particular installation, an individual trained in laser safety who is appointed by the commander to be responsible for control of laser hazards. The term Laser System Safety Officer is used by the Navy to differentiate the LSSO from the Landing Signal Officer (LSO). Each service's regulations will stipulate training requirements for LSOs/LSSOs and may, for example, differentiate among

- Laser Safety Consultants. Service experts who evaluate and advise on laser safety.
- Base Laser Safety Officer. Responsible for paperwork, administration, safety training, and compliance inspections at the installation, for example, Air Force Bio-Environmental Engineer (BEE), Army Radiation Protection Officer, or Navy Base Safety Office.
- Unit Laser Safety Officer. The individual in the laser user's chain of command who is responsible for all laser issues at the operational level, including but not limited to establishing unit specific laser regulations and procedures and ensuring compliance to the appropriate laser regulations and restrictions of the host facility, that the appropriate operational and safety training for the laser weapon shall be used, maintaining unit laser accountability, and ensuring that all other unit related laser safety issues are addressed.
- Range Laser Safety Officer. Responsible for the physical control of the Laser Range and for its use; including but not limited to establishing range specific Laser Safety Regulations and procedures and ensuring that all users comply with all appropriate laser safety regulations in place at the range. The Range Laser Safety Officer may be from the range installation or a visiting Unit Laser Safety Officer.

Laser Surface Danger Zone (LSDZ), Nominal Hazard Zone (NHZ). Designated region where laser radiation levels may exceed the maximum permissible exposure level.

Maintenance. Performance of adjustments or procedures to be performed by the user for ensuring the intended performance of the product. Maintenance does not include operation or servicing. This definition is equivalent to the DOD concepts of operator-performed maintenance and organizational maintenance. Organizational maintenance could include firing the laser.

Maximum Permissible Exposure (MPE). Laser radiation exposure levels published in ANSI Z136.1 and established for the protection of personnel. These are levels of laser radiation to which a person may be exposed without known hazardous effects or adverse biological changes of the eye or skin. The MPEs contained in ANSI Z136.1 are used in this handbook and are in concurrence with STANAG 3606.

Milliradian (mrad). Unit of angular measure. One mrad equals one thousandth of a radian. One degree equals 17.5 milliradians.

Micrometer (μm). A measure of length equal to 0.000001 meter (10^{-6} meter). Formerly termed micron.

Nanometer (nm). A measure of length equal to .000000001 meter (10^{-9} meter). Sometimes termed millimicron.

Night Vision Goggles/Devices. Any individual or crew served viewer which employs a nonthermal image intensification device (that is, ANVIS, cat's eyes, or AN/PVS-7).

Nominal Hazard Zone (NHZ). See Laser Surface Danger Zone.

Nominal Ocular Hazard Distance (NOHD). The distance along the axis of the laser beam beyond which the irradiance (W/cm^2) or radiant exposure (J/cm^2) is not expected to exceed the appropriate MPE, that is, the safe distance from the laser. The NOHD-O is the NOHD when viewing with optical aids.

Optical Density (OD). The following logarithmic expression for the attenuation produced by a filter such as an eye protection filter is

$$OD = \log_{10} (I_o/I_t)$$

where I_o is the power incident upon the filter and I_t is the power transmitted through the filter at a specific wavelength.

Optical Radiation. Electromagnetic radiation with wavelengths that lie within the range of 180 nm to 1 millimeter (mm). This radiation is often divided into three spectral regions by wavelength: ultraviolet radiation (180 nm to 400 nm), visible radiation (400 nm to 700 nm), and infrared radiation (700 nm to 1 mm).

Pulse Duration. The time increment measured between the half-peak-power points on the leading and the trailing edges of a pulse.

Pulsed Laser. A laser that delivers its energy in discontinuous bursts; that is, there are time gaps during which no energy is emitted. For the purpose of this handbook, a laser that emits a pulse for less than 0.25 second.

Radian (rad). A unit of angular measure equal to 57.3° .

Radiance (L). The radiant energy per unit solid angle emitted by a source

Radiant Energy (Q). Energy in the form of electromagnetic waves, usually expressed in units of joules. Commonly used to describe the output of pulsed lasers.

Radiant Flux or Power (Φ). The time rate of flow of radiant energy given in units of watts. Used to describe the output power of continuous wave lasers or the average output power of repetitively pulsed lasers.

Radiant Exposure (H). The radiant energy per unit area incident upon a given surface. It is used to express exposure dose to pulsed laser radiation and is commonly expressed in joules per square centimeter or joules per square centimeter per pulse.

Reflectance or Reflectivity (P). The ratio of total reflected energy to total incident energy.

Repetitively Pulsed Laser. A pulsed laser with a sequentially recurring pulsed output.

Service. The performance of those procedures or adjustments described in the manufacturer's service instructions that may affect any aspect of the product's performance for which this handbook has applicable requirements. Service does not include maintenance or operation as defined in this section. This definition is equivalent to DOD concepts of maintenance above the organizational level.

Solid Angle (Ω). The ratio of the area on the surface of a sphere to the square of the radius of that sphere. Solid angle is expressed in steradians.

Specular Reflector. A mirror like reflector at the wavelength of the incident radiation.

Steradian (sr). The unit of measure for a solid angle. There are 4π steradians in a sphere.

Support Equipment. Devices or enclosures procured specifically for or modified for laser test, calibration, maintenance, or other support not part of the primary laser mission.

Transmittance or Transmissivity (t). The ratio of total transmitted radiant power to total incident radiant power.

Ultraviolet Radiation. Electromagnetic radiation with wavelengths between soft x-rays and visible radiation. This region is often divided into three spectral bands by wavelength: UV-A (315 to 400 nm), UV-B (280 to 315 nm), and UV-C (200 to 280 nm).

Visible Radiation (light). Electromagnetic radiation that can be detected by the human eye. Visible radiation is commonly used to describe wavelengths that lie in the range between 400 and 700 nm.

Watt (W). The unit of power or radiant flux equal to 1 joule per second. Used principally with continuous wave lasers.

Wavelength (λ). The distance between two points in a periodic wave that have the same phase is termed one wavelength. The velocity of light in centimeters per second divided by frequency (given in Hz) equals the wavelength (given in cm).

CHAPTER 4

GENERAL RANGE CONTROL PHILOSOPHY

4.1 General Policy

Laser range safety is to prevent injury to personnel from laser radiation and misdirection of laser guided weapons. The objective of performing laser safety evaluations of DOD laser ranges is to provide guidance to protect personnel and property from misguided laser directed weapons and to ensure that no unprotected personnel are exposed to laser radiation above the protection standards specified in ANSI Z136.1. The goal is to accomplish this objection without placing unnecessary restrictions on laser system use. The safety evaluations shall be accomplished as described in the following subparagraphs.

4.1.1 Locate target areas where no line of sight exists between lasers and uncontrolled, potentially occupied areas within the NOHD for aided and unaided viewing.

4.1.2 Remove specular surfaces from targets and target areas. Do not use a laser to designate or range still water, flat glass, mirrors, glazed ice, plexiglass, or other specular reflectors.

4.1.3 Laser beams and the associated buffer zone must be terminated or the radiation level attenuated below the MPE limit within the controlled range or test facility or in controlled airspace. If energy below the MPE is allowed to leave the range, the possibility of optically aided viewing by unprotected individuals must be considered in the safety evaluation.

4.1.4 Lasers should be of the lowest emission level consistent with mission requirements.

4.1.5 On most ranges, some personnel and moving targets are required to be on the range during laser operations for instrumentation operations, munitions impact spotting, and other required activities. The locations of all occupied areas must be determined and evaluated relative to the laser hazard area. The type of laser protective devices required, if any, must then be determined for each occupied location.

4.1.6 Safety evaluations and degree of restrictions shall consider extent of range boundaries, required warning signs, number and location of specular reflectors, ease of public access to the range, airspace restrictions, local operating procedures, and environmental conditions (see Figures 4-1 and 4-2).

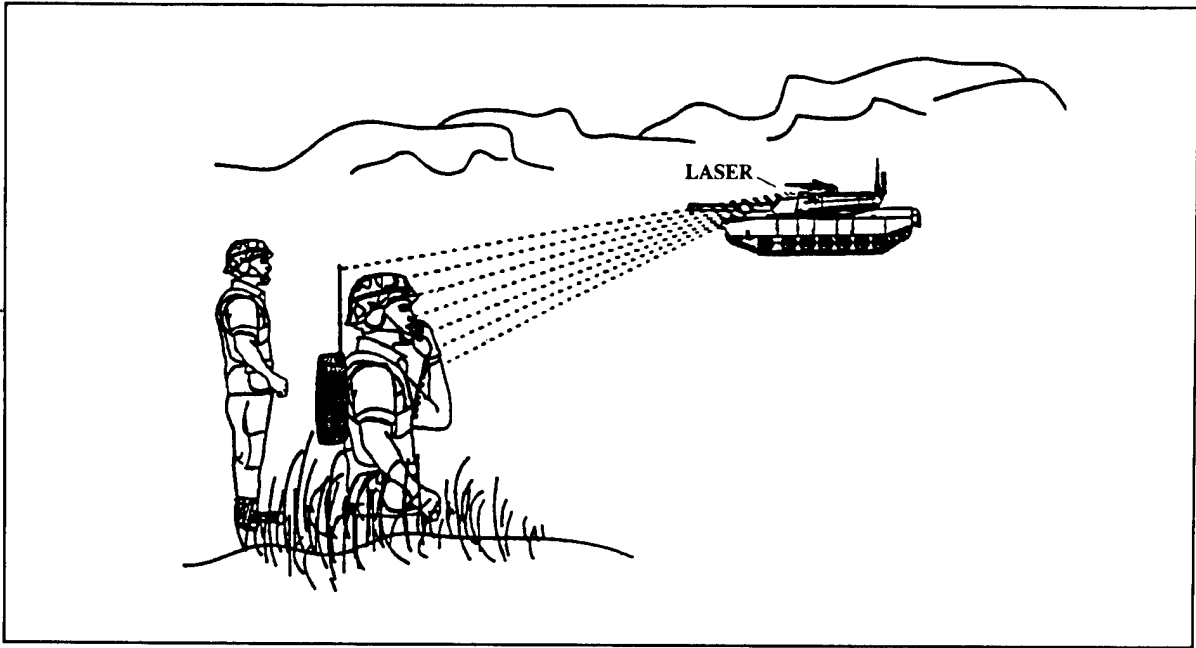

Figure 4-1. Direct intrabeam viewing.

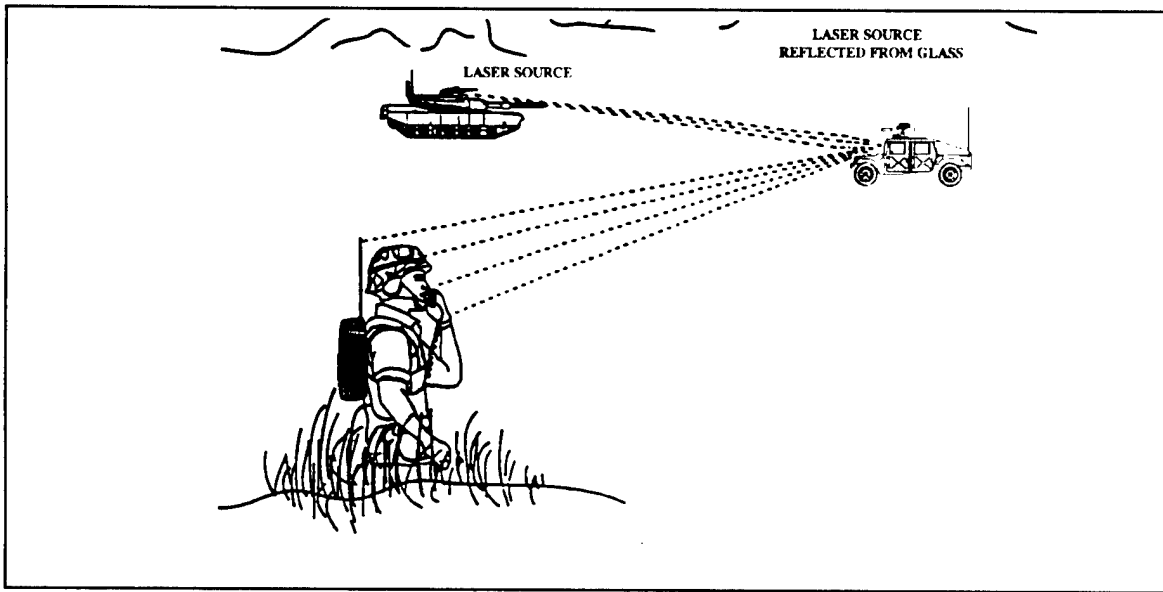

Figure 4-2. Reflected intrabeam viewing.

4.1.7 In joint laser exercises, all parties shall be informed of the intended laser operations prior to scheduling including the Range Control Office, Range Safety Office, LSO/LSSO/Radiation Protection Office (RPO), and Liaison Office for the services involved.

When coordinating with these offices, ensure that NOTAM and Notice to Mariners (NOTMAR) are prepared and issued in accordance with FAA, United States Coast Guard

(USCG), and National Imagery and Mapping Agency (NIMA) regulations as required. Ensure that use of class 3 or class 4 lasers above the horizon is approved by U.S. Space Command (Laser Clearing Housing) DSN 268-4496, or commercial (719) 474-4496.

4.2 Recommended Targets

Recommended target areas are those without specular (mirror like) surfaces. Glossy foliage, raindrops, fog, snow, and most other natural objects are not considered to be specular surfaces that would create ocular hazards. All reflectors posing a specular reflectance hazard shall be removed from the Laser Surface Danger Zone (LSDZ). Calm, smooth water and clean ice can reflect laser beams, especially at low angles of incidence. Consider these potential reflections when establishing target areas. If these potential reflections have not been considered for the approved target area, ranges shall be closed when water begins ponding on the ground.

4.3 Beam Control

When target areas have no flat specular surfaces, range control measures can be limited to the control of the beam path between laser and backstop.

4.4 Specular Reflectors

Specular surfaces within distances (see Appendix A, Tables A-1 and A-2) of the laser target, visible to unprotected personnel through binoculars or magnifying optics, will be removed, covered, painted, or destroyed. For lasers used from fixed wing aircraft, the entire buffered laser footprint area shall be cleared of specular reflectors (see Appendix E).

4.5 Hazards

4.5.1 Laser devices such as those listed in Appendix A, Table A-1 and A-2, can seriously injure the unprotected eyes of individuals within the hazard zone of the laser beam. Intrabeam viewing of either the direct beam or a beam reflected from a flat mirror like surface may expose unprotected eyes to a potential injury and must be avoided.

4.5.2 Every diffuse reflecting object that the laser beam strikes will reflect back some energy in all directions and toward the laser. This diffusely reflected energy will not be hazardous if the laser is located greater than a distance "t" from the target (see Tables A-1 and A-2). To avoid hazardous specular reflections, the area around the target must be cleared of specular (mirror like) reflectors. The hazard of exposure to the skin is small compared to the eye; however, personnel should avoid direct laser beam exposure to the skin within distance "t" from the laser.

4.5.3 A less severe hazard exists for the devices listed in the tables of Appendixes C and D, but intrabeam viewing of the laser beam at distances less than that specified with the unprotected eye should be avoided.

4.5.4 Dazzle and momentary flash blindness can occur from visible laser exposures below MPEs. Laser eye protection may not attenuate the radiation sufficiently to eliminate these effects. Appropriate precautions must be taken if personnel performing critical tasks, such as flying aircraft, may be exposed to laser radiation levels that may cause dazzle or momentary flash blindness.

4.6 Unprotected Personnel

Unprotected personnel must not be exposed to laser radiation in excess of the MPE from either the direct or reflected beam.

4.7 Warning Signs

Evaluation of each anticipated operating condition must include development of procedures for ensuring proper placement of warning signs. Local SOPs should provide for the placement of temporary signs during operation. Signs should be in accordance with AR 385-30, SPAWARINST 5100.12B, or AFOSH Std 161-10 (see Figure 4-3).

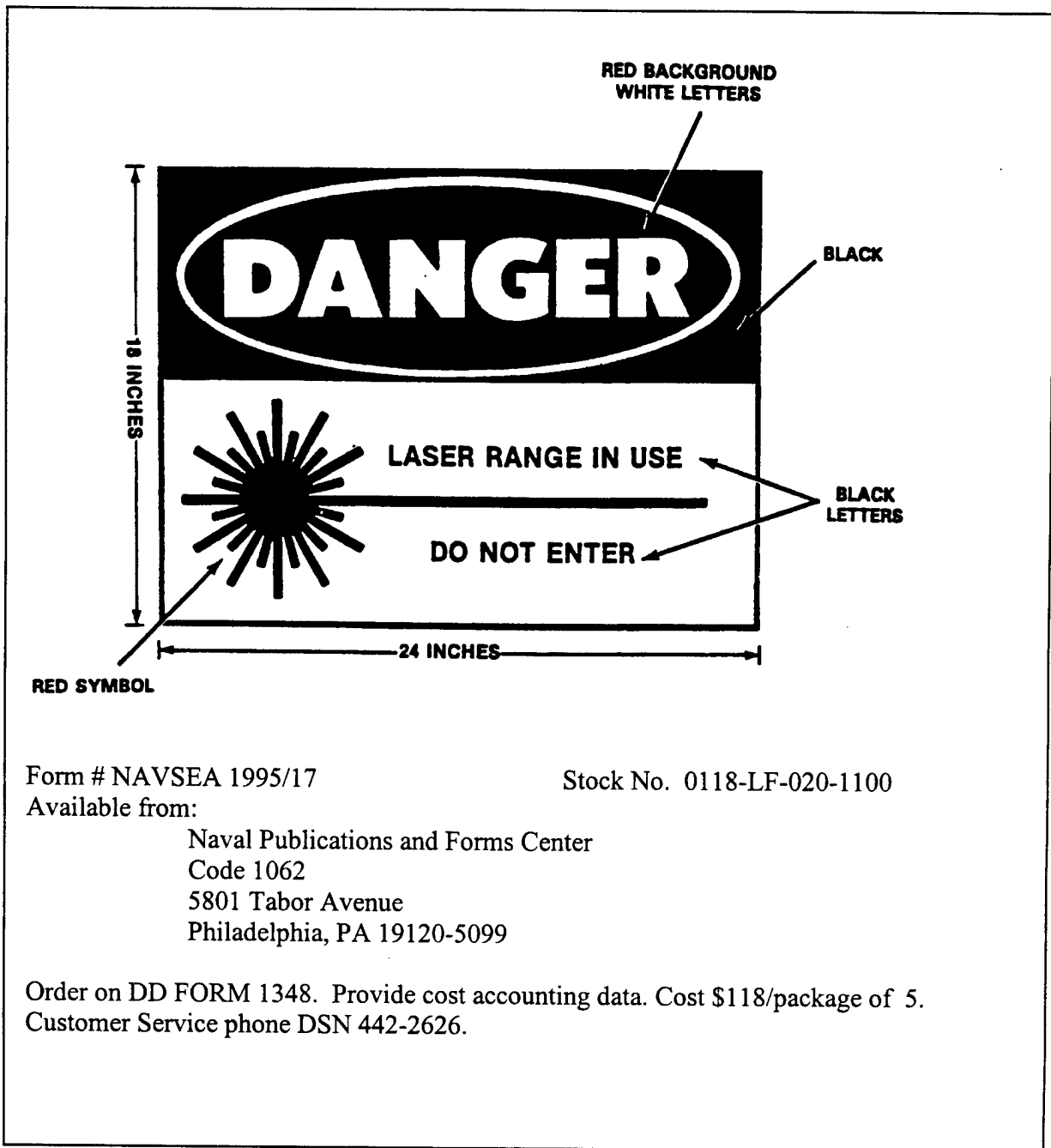

Form # NAVSEA 1995/17
Available from:

Stock No. 0118-LF-020-1100

Naval Publications and Forms Center
Code 1062
5801 Tabor Avenue
Philadelphia, PA 19120-5099

Order on DD FORM 1348. Provide cost accounting data. Cost \$118/package of 5.
Customer Service phone DSN 442-2626.

Figure 4-3. Example: warning sign.

4.8 Personnel Protection

Individuals within the horizontal or vertical LSDZ such as moving target operators, support personnel, and aircrew members should wear laser protective eyewear with curved protective lenses during laser firing. The curved lenses are necessary if there is a probability that laser eye protection will specularly reflect the beam into an uncontrolled area. Eye protection with side shields may be required if the laser beam can get behind the lens. Eyewear must be approved for the wavelength of the laser device being fired. A laser filter designed to protect against one wavelength of laser may not protect against harm from another. Appendix A, Table A-3 provides the wavelength and optical density required for the current fielded devices. If more than one type of device is used, protective measures must cover all devices. For devices of the same wavelength, the highest required optical density will be used.

4.9 Magnifying Optics

The use of magnifying daylight optical devices to observe the target during laser operation is permitted if flat mirror like surfaces have been removed from the target area. Mirror like targets can be observed only if appropriate laser safety filters are placed in the optical train of the magnifying optics. Protected optics such as sights must be so marked.

4.10 Night Vision Goggles (NVG)/Devices

Because NVGs provide a substitute for the human eye during night time operations, NVGs must be considered a mission critical item. Devices such as ANVIS or cats eye, MXU-810/U, are designed for aviators and are as important as the aviator's eyes during night time operations. Although some NVGs will protect the human eye from laser damage (NOTE: Cats eye NVG will not protect the human eye.) The damage threshold for NVGs may be as low or lower than the damage threshold for the human eye. The impact of damaging the aviator's NVGs during flight could be fatal. Therefore these devices must be physically (optical or electrical) or procedurally protected from laser damage. Many resources exist to determine the safe operating ranges for NVGs and several service-specific points of contact are listed below:

Naval Research Laboratory
Code 6656
4555 Overlook Avenue
Washington, DC 20375-5345
(202) 767-6978

USA CECOM NVESD, AMSEL-RD-NV-LPD
10221 Burbeck Road, Suite 430
Fort Belvoir, VA 22060-5806
(703) 704-2031

Wright Laboratory/MLPJ Building 651
3005 P Street, Suite 1
Wright Patterson AFB, Ohio 45433-7702
(513) 255-3808, ext-3169

4.11 Specific Guidelines

These specific guidelines are provided as a minimum to ensure proper control of hazardous laser energy:

4.11.1 Publish and enforce safety regulations for laser usage in specific areas. Provide detailed written procedures to minimize laser radiation hazards and other laser related range hazards such as erroneously homing on the laser target designator and wrong targets.

4.11.2 Assign a laser safety officer (LSO) at the base, range, and user levels as defined in chapter 3 to be responsible for ensuring appropriate safety control measures are followed.

4.11.3 Require users to prepare a safety SOP for each different laser system and different type of laser operation. At any enclosed area such as a preliminary laser testing facility, post a generic safety SOP.

4.11.4 Keep records of the date, start and stop time for lasing periods, and type of laser or other appropriate information for each laser operation.

4.11.5 Post the range boundaries to advise the public of the presence of laser operations, where deemed appropriate by the local laser safety officer. These signs shall be in accordance with MIL-STD-1425 (see Figure 4-3).

4.11.6 Fire lasers only at authorized targets.

4.11.7 Where possible, use eye-safe attenuating filters over the laser output.

4.11.8 Do not fire the laser at still water, flat glass, mirrors, glazed ice, Plexiglas, or any other specular reflectors, unless specifically authorized by the Laser Safety Officer.

4.11.9 Do not fire the laser at aircraft, unless specifically authorized by the Laser Safety Officer.

4.11.10 Before operating fire control lasers or rangefinders, be certain that the target is positively identified under the crosshairs of the scope, or on the operator's monitor, or in accordance with specific safety procedures approved by the Laser Safety Officer.

4.11.11 Cease laser operations if the operator or range control is dissatisfied with target tracking.

4.11.12 Cease laser operations if unprotected or unauthorized personnel enter the laser hazard area.

4.11.13 Clear the range using range personnel or by a flyover of the range to ensure that no unprotected or unauthorized personnel are in the laser hazard area, including all boats where island or shoreline ranges are involved.

4.11.14 For air operations, cease laser firing if unprotected or unauthorized aircraft enter the operations area or a restricted zone between the aircraft carrying the laser and the target. The restricted zone for most fire control lasers is defined as 20 times the assigned buffer zone. For example, when using a laser with an assigned buffer zone of 5 milliradians, the restricted zone around the laser beam out to the NOHD for other aircraft with unprotected personnel would be a 100 milliradian or 5° (half angle) cone surrounding the laser LOS to the target with the aircraft carrying the laser at the apex.

4.11.15 Maintain two-way communication between the laser system operators and all affected range personnel.

4.11.16 Establish a laser operator training program.

4.11.17 Provide a pre-mission brief to all laser operators and affected personnel prior to laser operations. The brief shall include all potential hazards such as radiation and weapons misguidance, control measures specific to the lasers employed, and the range upon which they are used. As a minimum, the brief shall include

4.11.17.1 maps depicting the targets, target areas, and their laser hazard area;

4.11.17.2 drawings or photographs of the target/targets to be used;

4.11.17.3 run-in headings and flight profiles to be used for airborne laser operations and permissible firing fans for ground based laser operations; and

4.11.17.4 review of mission profiles to prevent misguidance of laser guided weapons (LGW) by ensuring that the LGW or laser spot tracker field of view (FOV) always encompasses the target and does not encompass the space near the laser designator.

4.11.18 Do not direct class 3 and 4 lasers above the horizon unless coordinated with the US Space Command (Laser Clearing House) and with the regional FAA office for laser radiation above the MPE outside restricted airspace (see Appendix I).

4.11.19 Ensure ground based lasers are at the approved operating position or firing points and always pointed down range toward the target.

4.11.20 For ground based lasers, ensure all unprotected personnel in the immediate area of the laser firing position are outside the laser surface danger zone or behind the laser operator while the laser is in use. Laser eye protection is not required for laser operators or observation personnel viewing a target area from which specular reflectors have been cleared, even when binoculars are used. However, personnel must never enter the LSDZ without appropriate eye protection.

4.11.21 Medical surveillance, especially of down range target area personnel, shall be in accordance with each service's medical regulations. Immediately report any suspected injury or defective equipment (for example, misalignment of the laser beam with the pointing optics) to the cognizant supervisor, so appropriate action can be taken to remove the product from service until it has been cleared for operation by competent authority. Include laser injuries in the local medical emergency plans. Timeliness in examination and treatment of suspected laser injuries by specialists to prevent further internal damage is of the utmost importance. The following commands retain ophthalmologists trained in treating laser injuries:

USAMRD-BAFB
7914 A Drive
Brooks Air Force Base, Texas 78235-5138
Commercial: (210) 536-4622
DSN: 240-4622
Fax: (210) 536-3450

AL/OEO
8111 18th Street
Brooks Air Force Base, Texas 78238-5215
Commercial: (210) 536-4816
DSN: 240-4816
Fax: (210) 536-3903

AL/AOCO
2507 Kennedy Circle
Brooks Air Force Base, Texas 78235-5117
Commercial: (210) 536-3241
DSN: 240-3241
Fax: (210) 536-5165

Brooks Air Force Base Command Post is manned at all times: DSN 240-3278, Commercial (210) 536-3278

4.11.22 Do not operate the laser or use it experimentally outside the range area without the operation being specifically authorized by the local LSO. Follow the safety procedures of ANSI Z136.1 for laser operations within any indoor firing pretest or laser testing facility. For example, use electrical door interlocks to prevent laser firing if entry door is opened.

4.12 Laser Pre-firing and Post-Firing Restrictions

When lasers are not in use, hazardous laser output shall be prevented by use of such devices as output covers or rotating the laser into the stow position, unless otherwise specifically authorized by the local LSO. The following subparagraphs should be included in pre and post-firing checklists.

4.12.1 Any maintenance performed in a range environment must be in accordance with operating procedures approved by the local LSO.

4.12.2 Pre-fire checks that require operation of the laser may be made in a controlled area with the laser beam terminated by an opaque backstop. Pre-fire checks that do not require operation of the laser, but require use of the optics, may be safely made in a controlled area. To operate the optics without firing the laser, institute operating procedures to ensure power to the laser is turned off in accordance with local lock-out/tag-out procedures.

4.12.3 The laser exit port must be covered or laser otherwise stowed and turned off when transiting the range or traveling on public highways or in uncontrolled air space or shipping lanes.

4.12.4 Non-laser operations such as viewing through common optics can be conducted in a non-laser controlled area with the laser exit port cover removed. This non-laser operation can be accomplished by instituting procedures that ensure power to the laser is turned off.

4.13 Stationary Continuously Operating Lasers

Uses of lasers such as the light detection and ranging (LIDARs) or space probes operating continuously in airspace may require additional controls. Besides coordinating these emissions with the FAA and Space Command, automatic shut down features may be necessary to prevent illumination of aircraft above MPE or to prevent glare danger. These shut down features could be a radar beam which senses incoming craft or an aircraft transponder which signals the laser to shut down (see Appendix I).

4.14 Tactics

Laser guided munitions and other laser detectors have unintentionally acquired radiation sources within the field of detection other than the target resulting in fratricide. Fields of detection vary and are specific to individual weapons. All tactics must be planned to ensure that the angle between the laser designator LOS and laser detectors (for example, laser guided munition, laser spot tracker, and NVG) will not mistakenly aim the munition at the laser source or scattered radiation from the laser platform, see Joint Chiefs of Staff publication 3-09.1 (JLASER).

4.14.1 Ground Laser Designators. When employing laser spot trackers with ground laser target designators, the following procedures will be used

4.14.1.1 Terminal controllers will provide aircrews with an attack heading or laser-to-target line. The attack heading must allow aircrews to acquire the laser energy reflected from the target. Ensure designators for other targets on the range are not using the same laser codes.

4.14.1.2 Because of the possibility of false target indications caused by atmospheric scatter from the laser beam within short distances from the laser exit port, attack headings should avoid target-to-laser designator safety cones unless the tactical situation can safely dictate otherwise. (The safety cone is usually defined as a 20° cone whose apex is at the target and extends 10° degrees either side of the target-to-laser designator line.) The scattered radiation that the seeker can detect may be caused by both Rayleigh and Mie scattering. Rayleigh scattering of radiation from atmospheric molecules is what makes the sky blue. It is strongest for shorter wavelengths (varies inversely by the fourth power of the wavelength) and is about twice as strong at 0° and 180° than at 90° from the laser LOS. However, at 90 degrees, it shows the greatest polarization. Mie scattering from aerosols is very strong in the forward direction of the beam even in the cleanest of atmospheres. It is not as dependent on wavelength as Rayleigh scattering and has no strong polarizing effect.

4.14.1.3 The optimal attack zone is a 50° zone from 10° to 60° either side of the target-to-laser designator line and at an elevation that will ensure adequate target acquisition. The risk of acquiring the laser designator instead of the target in this zone varies from moderate to low as the angle increases.

4.14.1.4 WARNING. The degree of hazard to ground personnel operating the laser target designator varies with the attack angle of Laser Spot Tracker from the laser LOS. See Figure 4-4. In some situations, laser spot trackers have shifted from the designated target to the laser target designator while operating in the 50° attack zone. For this reason, laser spot trackers should not be used as the sole source for target verification. Aircrews should verify they are attacking the target through additional means such as visual description or non-laser target mark. At a minimum, the laser spot cue provided in the cockpit must be evaluated and compared to the expected target location. For close air support missions, the target location given in line 6 of the 9-line brief should

be used to confirm the laser spot. For aircraft equipped with an Inertial Navigation System (INS) or Global Positioning System (GPS), steering cues provided by these aids should always be used to back-up the laser mark. Additional aids include, but are not limited to, visual target description, laser pointers, or non-laser target marks provided by direct or indirect fire from conventional weapons. If the laser spot tracker cue is not coincident with the expected target location, aircrew should not deliver ordnance on the laser spot.

To reduce the potential for seeker lock-on to the designator position, the designator should be masked from the seeker field of view. Terrain, vegetation, or other obstruction can sometimes mask the designator.

WARNING: DOES NOT GUARANTEE THAT THE LASER SEEKER WILL NOT LOCK ON TO THE LASER DESIGNATOR.

When the seeker's acquisition can be monitored by watching the aircraft with the laser spot tracker or seeing a laser guided bomb (LGB), it may be possible to detect an improper lock-on in time to prevent a mishap by aborting the bombing run. See Figures 4-4 and 4-5 for an example of a plan for ground laser designator tactics. Refer to individual Laser Spot Tracker/Laser Guided Weapons technical orders and procedures for additional safety information.

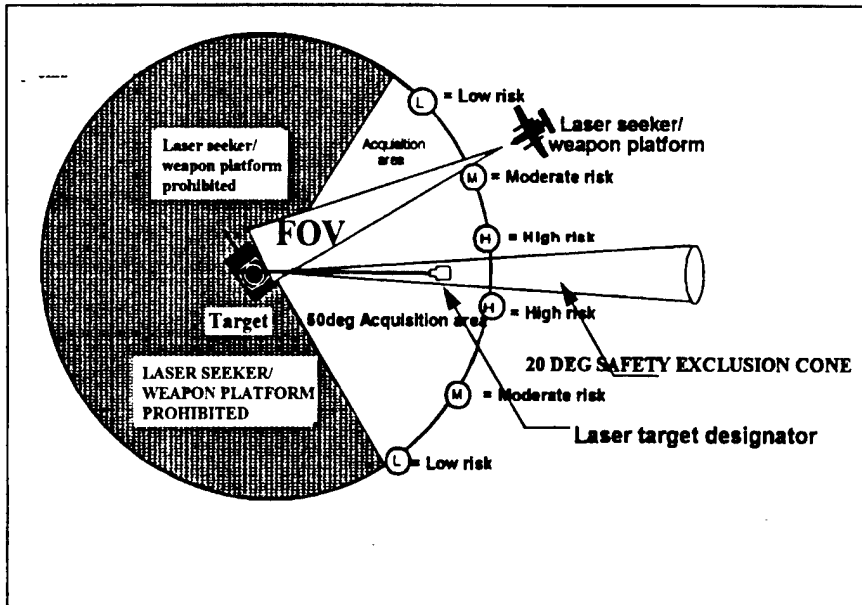

Figure 4-4. Sample Safety exclusion cone for ground laser designator.

NOTE : Situational check must ensure seeker field of view covers the target and not the area of the laser target designator out to a distance in front of the designator where scatter cannot be detected by the seeker. Because this is an example, details should be obtained from system specific documents and publications such as JCS PUB 3-09.1.

4.14.2 Airborne Wingman Laser Designation. Laser guided weapons (LGW) or laser spot trackers (LST) can erroneously lock onto the scattered radiation from buddy lase or wingman aircraft laser designators. In addition, if the airborne laser designator is pointing towards the LGW or LST, the designator itself may be tracked. In lock-on-before-launch (LOBL) mode, the LGW seeker LOS can be displayed in most launch aircraft. If the LOS cue is well above the horizon, then the missile is probably locked onto an erroneous spot such as the designator aircraft or atmospheric scatter instead of the desired target spot, and the mission should be aborted. If the LGW is employed in the lock-on-after-launch (LOAL) mode, no LGW LOS cueing is provided to the launch aircrew. Wingman designators must be aware that even if a LOBL is planned, launch aircrews train to employ the missile in a LOAL mode if a laser spot is not received once clearance to launch has been given.

4.14.2.1 If the missile properly locks onto the target in an LOBL mode, the only risk to the designator would be a midair potential if the designator aircraft is operating below the missile trajectory apex. In an LOBL mode, the wingman aircraft altitude should remain substantially above the nominal LGW apex altitude, keeping in mind that missiles can climb to altitudes well in excess of their nominal apex values especially if they are tracking a laser designator.

4.14.2.2 When employed in an LOAL mode, the laser guided missile will execute a climbing profile searching for a laser coded energy prior to tipping over and scanning its FOV along the ground. The risk to the wingman designator is highest during the initial staring phase of the LGW profile. If it locks onto the designating aircraft, there is a high probability that it will track and kill the laser designator. The dimensions of the instantaneous FOVs of the LGWs are not absolute, and some are capable of detecting forward or back scattered radiation at many degrees off boresight.

4.14.2.3 The geometry and timing for buddy/wingman lase tactics must be precise to preclude the weapon from targeting the designating platform. Designator profiles behind the launch platform are inherently the safest. If that is not possible, a designator profile must be selected that will keep the aircraft out of the LGW FOV. Figures 4-6, 4-7, 4-8 and 4-9 show examples of laser designator NO FLY CONE profiles. Refer to individual LST/LSW technical orders and procedures for additional safety information. Ensure other designators on the range are not using the same laser code.

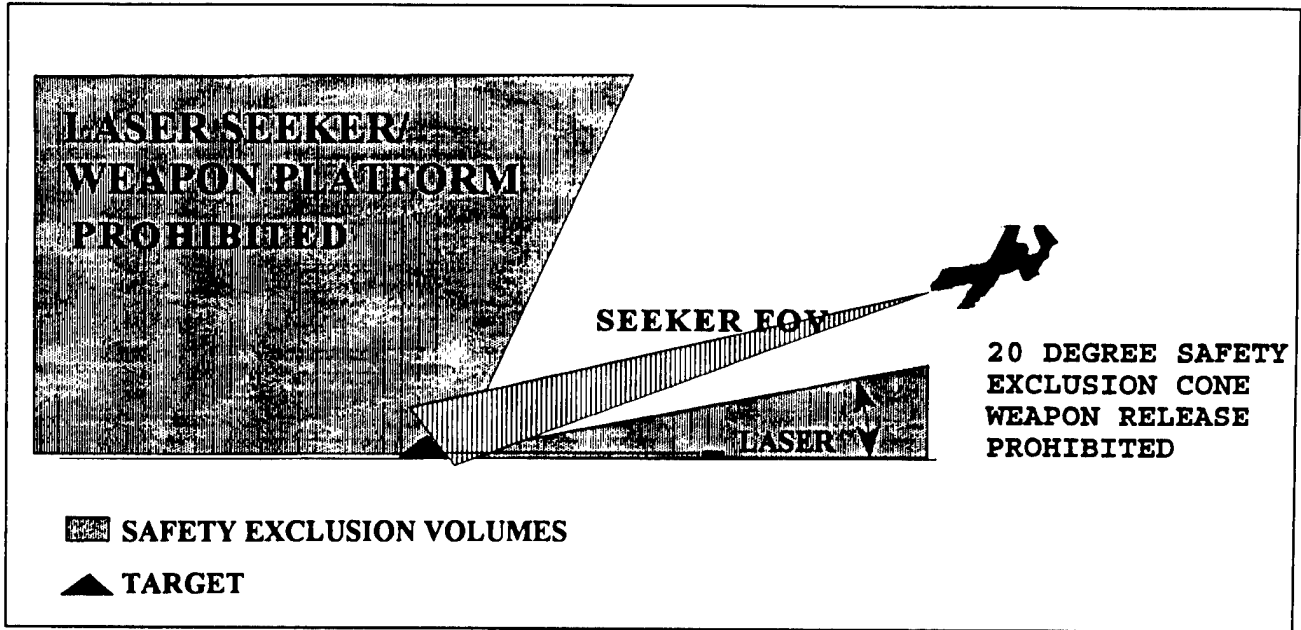

Figure 4-5. Sample side view of safety exclusion volumes for ground laser designator.

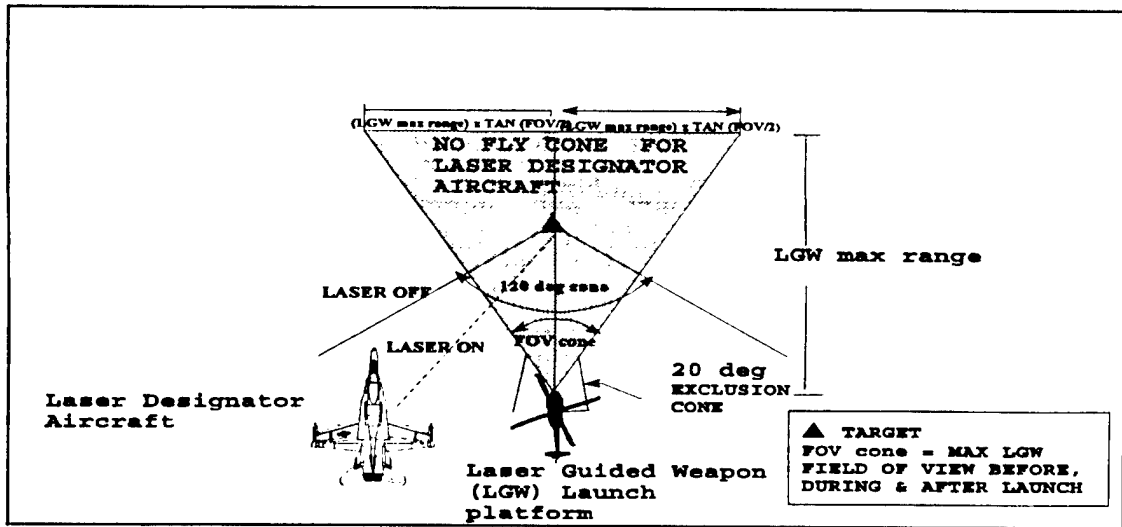

Figure 4-6. Sample plan view of safety exclusion cones to prevent homing on laser designator aircraft during continuous laser designation.

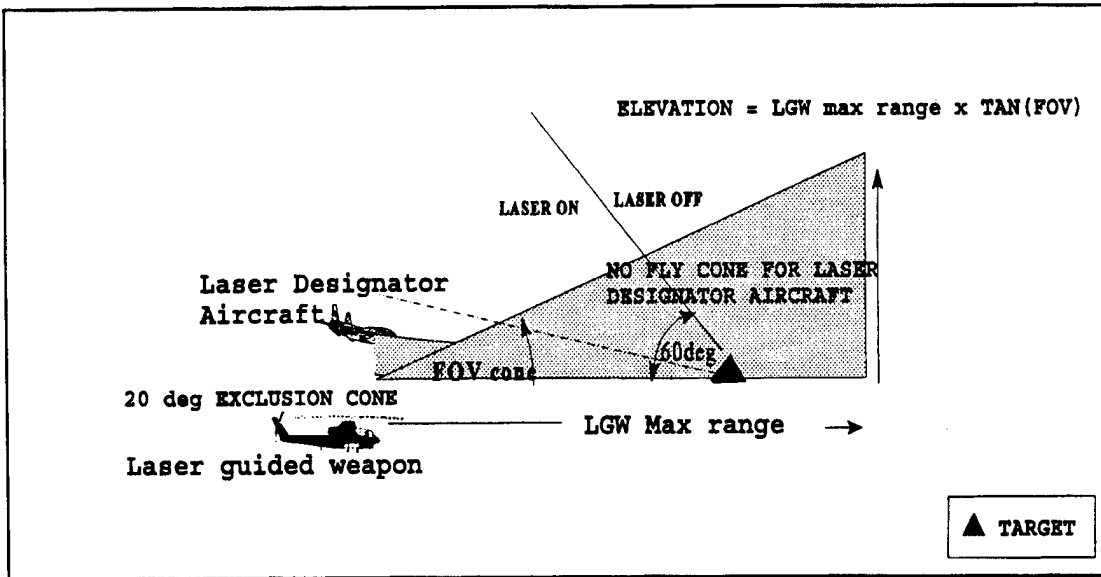

Figure 4-7. Sample vertical view of safety exclusion cones to prevent homing on continuous laser designator aircraft.

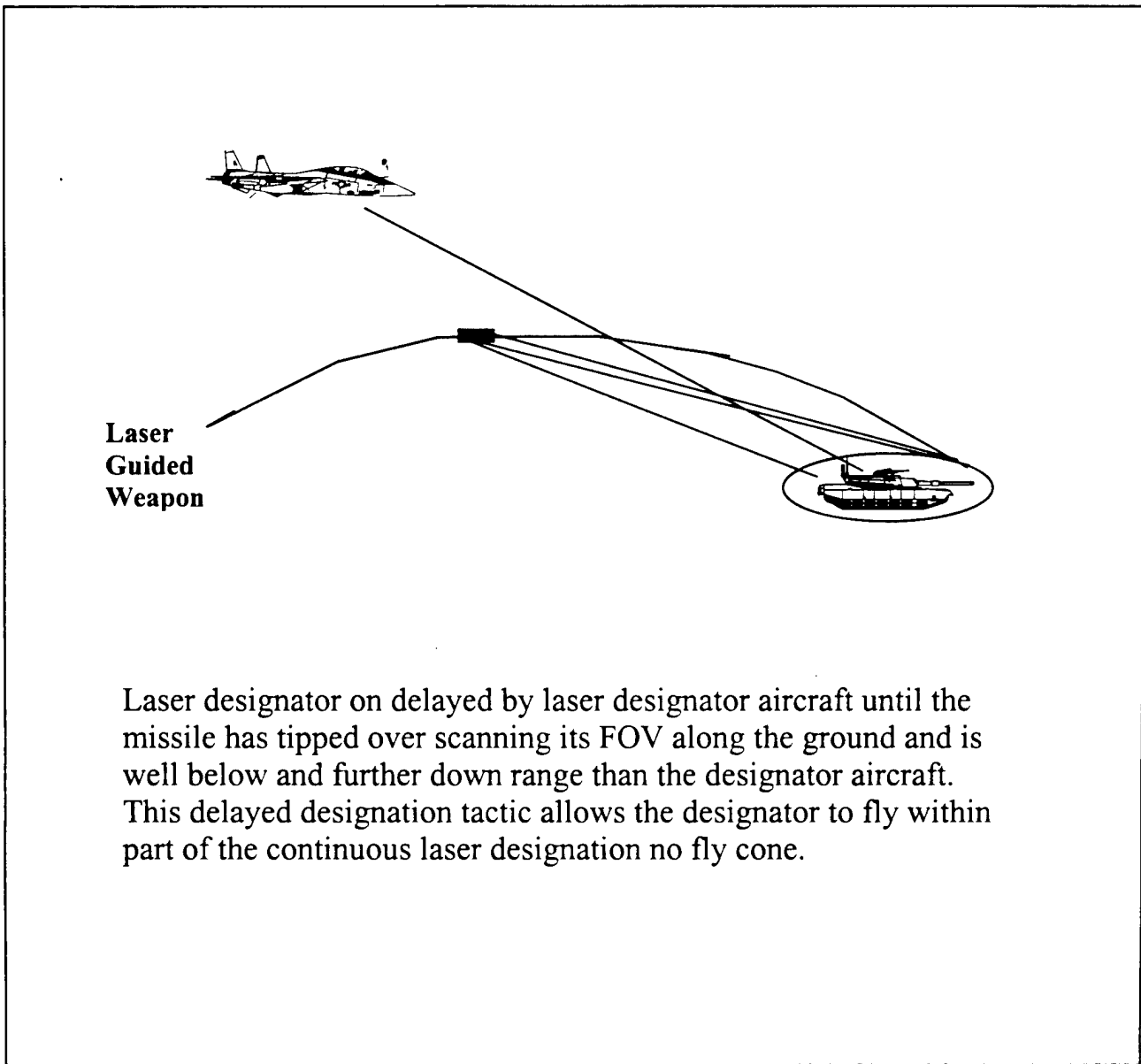

Figure 4-8. Sample delayed laser designation safety exclusion cone, vertical view.

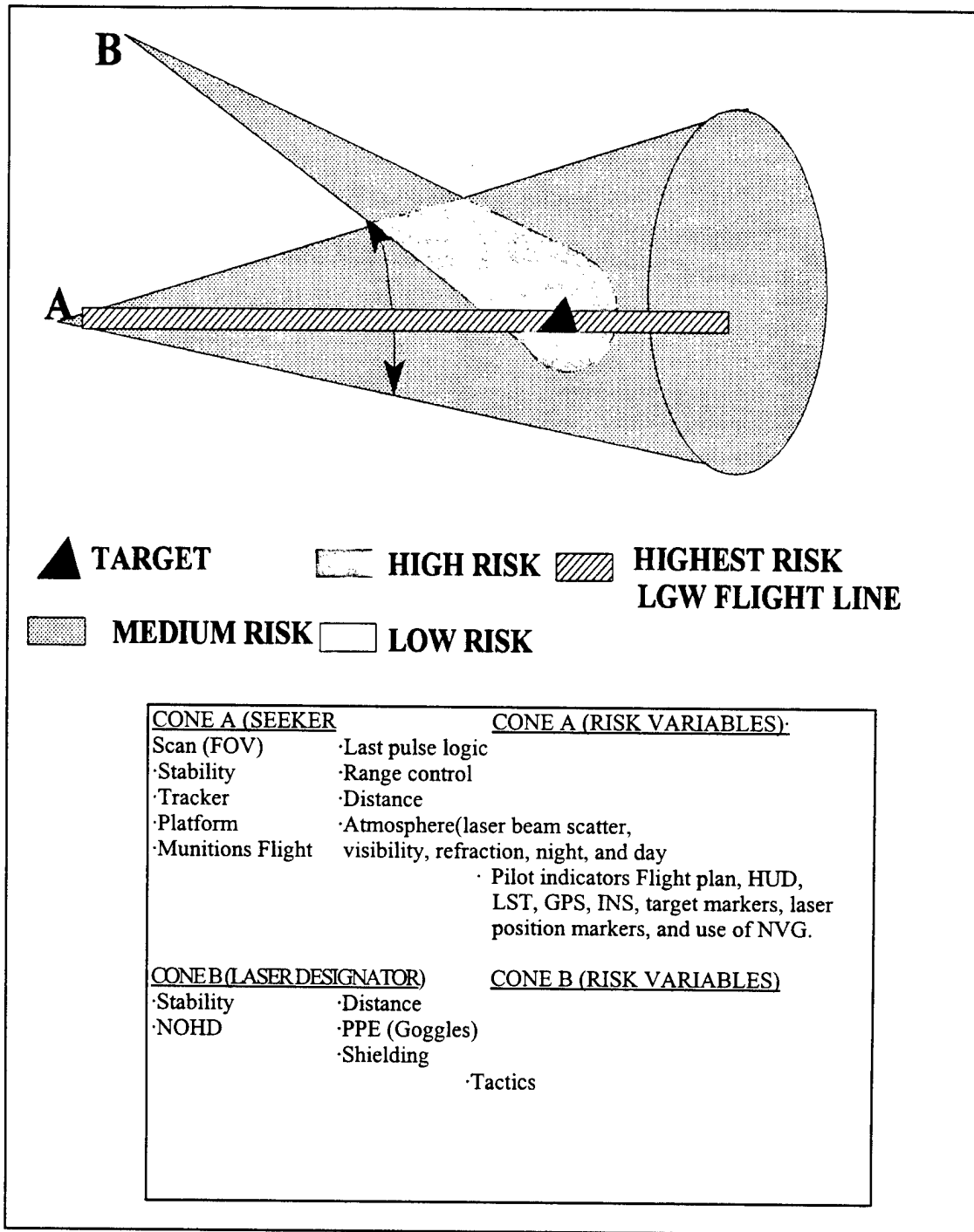

Figure 4-9. Generalized concept of risk variables related to laser target designator and laser seeker field of view (FOV) for laser guided weapons (LGW).

NOTE: To minimize risk of fratricide, ensure the target is always in the seeker FOV when the laser designator is on and minimize intersection of the laser seeker FOV with the laser beam especially close to the laser.

CHAPTER 5

RANGE EVALUATION PLANNING REQUIREMENTS

5.1 Background

Prior to any laser range operations, the hazards of using the system on the range must be fully evaluated. Both the laser user and the range control personnel must mutually agree on the conditions for laser operations. A sample checklist is provided in Appendix F for this data collection.

5.2 Laser User

The laser user shall provide

5.2.1 technical orders, technical manuals, and reports on the laser system and associated hazards as requested by the range evaluator;

5.2.2 the NOHDs and sources of evaluations or the parameters required to perform the safety evaluations;

5.2.3 standard operating procedures on the laser;

5.2.4 intended operational environment for laser use including types of targets and position, laser firing locations, run-in headings, maximum and minimum firing altitudes and ranges, direction of laser operations, and any other special considerations;

5.2.5 laser systems parameters; and

5.2.6 hazardous failure modes, that is, those that affect laser parameters or beam steering, secondary beams, inadvertent firing, and other potential system problems.

5.3 Range Operator

The range operator shall provide

5.3.1 local instructions that outline general range operating and safety requirements and

5.3.2 detailed range maps showing laser location, target location, restricted airspace or artificial backstops, flight path, range boundaries, populated areas, public roads, and no lase areas.

5.4 Range Evaluator

The range evaluator will review laser system data, maps, targets, instructions, SOPs, and other information provided by the laser user and range operator to determine which existing requirements impact the safety of laser operations on the range such as

- 5.4.1 limitations on allowable laser locations and run-in headings for aircraft,
- 5.4.2 minimum and maximum flight altitudes (airborne platforms only),
- 5.4.3 airspace surveillance,
- 5.4.4 flyover requirements to ensure range security,
- 5.4.5 locations of control towers and other manned areas
- 5.4.6 locations of non-controlled personnel access to the areas surrounding the target area,
and
- 5.4.7 specific information on maintenance, boresighting, or other activities on the range.

CHAPTER 6

RANGE EVALUATION REQUIREMENTS

6.1 Evaluation Sequence

A laser range evaluation can be performed for a specific laser system or for a group of similar lasers. An evaluation of a group of similar lasers is recommended if available land permits and the mission is not severely impacted. To perform this general evaluation, the worst case conditions of all possible systems and missions are used. If these conditions are too restrictive, separate evaluations for each system must be performed. The evaluation should be conducted on site at the laser range including a flyover, drive-through, and walk-through inspection. To simplify the range evaluation procedure, it may be divided into five steps: laser; range; target; mission; and laser surface danger zone.

6.1.1 Laser. To evaluate a laser for use on a range, it is necessary to determine the hazard potential of the system by determining the following items.

6.1.1.1 Maximum Permissible Exposure (MPE) Limits. Determine the applicable MPE for the laser being evaluated. The MPEs are provided in ANSI Z136.1.

6.1.1.2 Laser Classification. Classify the laser using the procedures in MIL-STD-1425 to determine what laser control procedures are required such as interlocks and warning labels.

6.1.1.3 Nominal Ocular Hazard Distance. Determine the distance from an operating laser to the point where the laser is no longer an eye hazard by using the procedures designated by the specialists listed in subparagraph 1.2.2 or use the values given in appendixes A and C.

6.1.1.4 Reflections. Determine if the laser is capable of producing hazardous reflections under established conditions using procedures designated by specialists listed in subparagraph 1.2.2 or appendixes A and C.

6.1.1.4.1 Specular Reflections. Determine what kinds of surfaces will act as specular reflectors at the laser wavelength (see Figure 6-1, Table 6-1, and Appendix G).

6.1.1.4.2 Diffuse Reflections. Determine if the laser is capable of producing hazardous diffuse reflections. Lasers that can produce hazardous diffuse reflections are classified as class 4 and have an associated diffuse reflection hazard distance (t). It is unusual for field type lasers to produce diffuse hazards. Presently, only the M60 tank, the M551A1 Sheridan Vehicle, and the OV-10D Night Observation System produce hazardous diffuse reflections. Normally for a diffuse hazard, the beam path out to the distance, t, as provided in Table A-1, is a denied occupancy area and no objects are permitted in the beam path out to this distance.

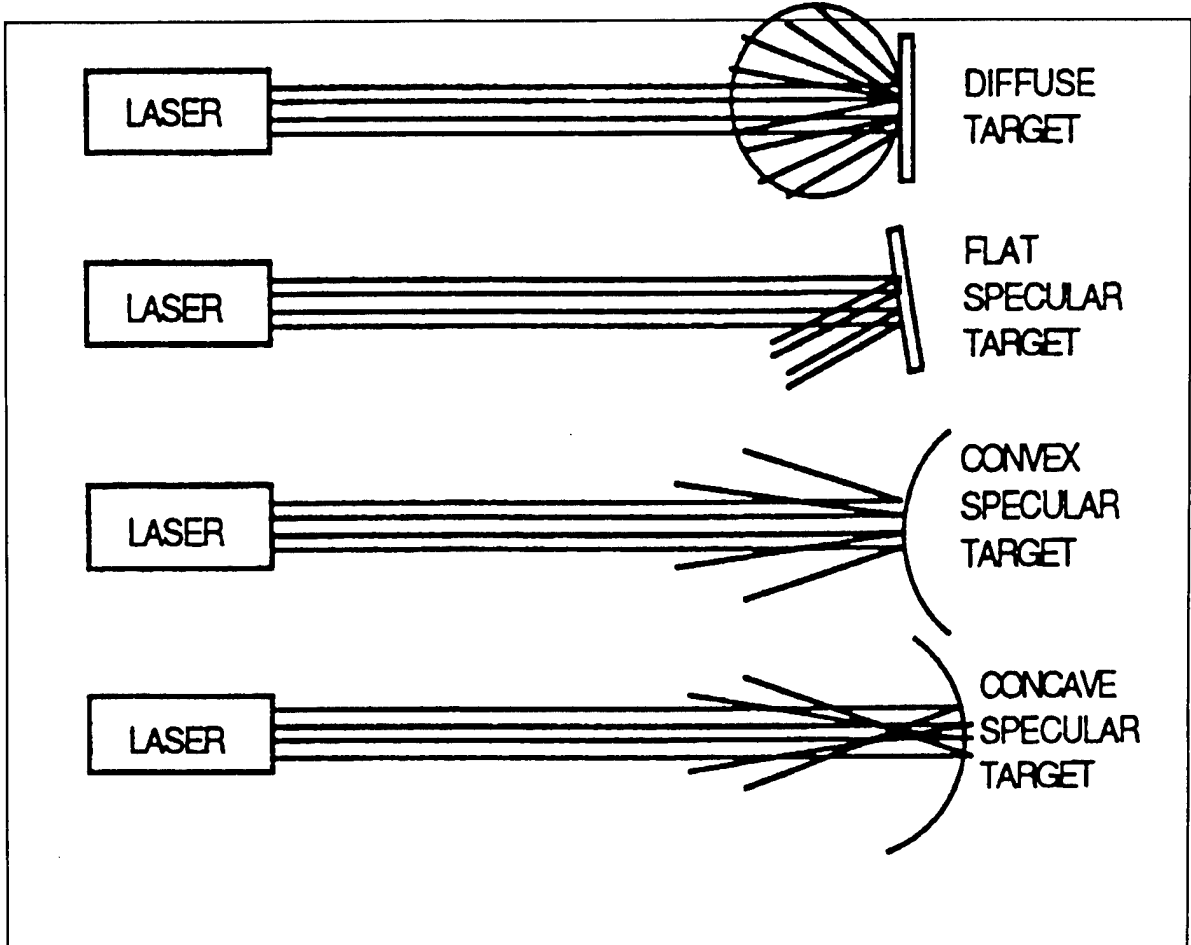

Figure 6-1. Diffuse reflection and specular reflection.

TABLE 6-1. Typical Reflective Surfaces

Diffuse Reflectors	Flat Specular Reflectors	Curved Specular ¹ Reflectors
dry foliage	flat glass ²	wet foliage
rocks	vision viewblocks	beer bottle
camouflage	still water ³	turbulent water
soil	vehicle rear view mirror	glossy paint
matte paint	instrument gauges	optical sights
aluminum cans	flat windows ²	curved windows
old ordnance	detector windows	automobile bumpers

¹ Generally not a hazard beyond a few meters.
² See Table G-1 for reflectivity at various angles of incidence.
³ Unrippled surface such as puddles and ponding on any surface.

6.1.1.5 Optical Density. The degree of protection required to reduce the incident laser energy to safe eye and skin levels must be determined. These levels are available in appendixes A and B and from the designated specialists listed in subparagraph 1.2.2.

6.1.1.6 Optical Viewing. Consider the possibility of personnel directly viewing the beam (intrabeam viewing) or reflections of the beam through optical instruments such as binoculars. The light gathering ability of the optics can significantly increase the degree of hazard for the eyes (increase OD and NOHD). Procedures to evaluate this hazard are in AFOSH Standard 161-10, ANSI Z136.1, and TB MED 524. Some evaluation results are included in appendixes A and B.

6.1.1.7 Atmospheric Attenuation. Atmospheric attenuation can be quite high for infrared lasers operating over distances of 10 kilometers or greater. It can reduce the NOHD considerably and should, therefore, be included in the laser evaluation.

6.1.1.8 Laser Platform Stability. The stability of the laser platform must be evaluated to determine the pointing accuracy of the laser system. The pointing accuracy will determine the size of the buffer angle. The typical buffer angle for airborne (aircraft), ground based, or shipboard stable platforms (tripods) is 5 milliradians, while hand-held lasers normally require 10 milliradians. Paragraph 6.8.1 further discuss the buffer angle.

6.1.2 Range. A range map, a topographic map, and an air space map of the area are needed for the laser range evaluation.

6.1.2.1 Range Map. The range map is essential to establish accurate distances from target area to range boundaries. The range map should show the boundaries and include geographic items such as towers and buildings. Boundaries of special purpose areas such as an airstrip and the location of the targets are required.

6.1.2.2 Topographic Map. The topographic map is important because it enables the evaluator to determine the elevation of the target area relative to the surrounding terrain. It is important that no portion of the beam, which exceeds the MPE limits, extends beyond the controlled area. Using natural geographic backstops such as hills can control the beam. A topographic map is very helpful in identifying these backstops and in repositioning targets if necessary.

6.1.2.3 Airspace Map. Controlled airspace is that airspace associated with the range having specific, possibly non-coincident lateral boundaries and a specific minimum and maximum altitude. It is important that this controlled airspace and any other special conditions are made known. Laser operations are not normally authorized outside the controlled airspace or when other aircraft are between the laser and the target. In addition, if the beam is directed up, or if hazardous reflections could exceed the height of the controlled airspace, additional controls may be necessary.

6.1.3 Target and Target Area. The size, location, and type of targets to be fired at on a range are of primary importance in determining the hazard zone.

6.1.3.1 Optimum Target. The optimum target from a safety point of view is a non-reflective surface. Flat specular surfaces must be removed or covered, because reflections from these surfaces can retain high collimation. A flat specular surface is one in which a relatively undistorted image can be seen. Examples of specular surfaces are windows, Army tank vision blocks, searchlight cover glass, plastic sheets, glossy painted surfaces, still water, clean ice, flat chrome, and mirrors. Snow is not a specular surface, but if thawed and refrozen, hazardous reflections can be found especially at low angles of incidence. Glossy foliage, raindrops, and other natural objects are not hazardous targets since their curved reflective surfaces as well as other curved reflective surfaces cause the beam to spread and the reflected irradiance (energy per unit area) decreases quickly with distance. The only exception is concave reflective surfaces, which can focus the reflected beam and cause the reflection to be more hazardous than the incident beam. Practically, these reflections are of little concern because it is improbable that the surface is perfectly concave (focuses the beam to a single point) or perfectly reflective. Additionally, the focal points of concave reflectors would probably be very close to the object (small radius of curvature) and be of little concern, because people do not normally put their head close to objects and if they did, they would probably block the incident beam. Concave surfaces with a large radius of curvature which could focus at longer distances would appear nearly flat and must be removed or covered. Although curved surface reflection may not be hazardous at typical laser-to-target engagement ranges, large shiny curved surfaces should be removed. An example of such a surface is a curved automobile bumper. Lastly, a diffuse surface is one that totally distorts (or diffuses) the beam shape, normally resulting in a safe-to-view reflection from outside the target area. Table 6-1 lists

some common items found in a typical range area and their type classification for reflection. Appendix G provides additional information.

6.1.3.2 Size and Location. The number and location of targets (distribution) will affect the size of the hazard zone. On ranges with limited space, it is important that all targets be as close together as tactically feasible.

6.1.3.3 Separate Target. See Appendix H for Navy separate target (SEPTAR) operations.

6.1.4 Mission. An evaluation must be made for each type of laser used on the range. The laser operating mode, that is, air-to-ground, ground-to-ground, ship-to-target must be determined. At the present time, air-to-ground, ground-to-ground, and ship-to-target are the normal modes used by tactical forces. In the near future, training exercises and tests will include the ground-to-air mode as more state-of-the-art airfields and ground force air defense systems are developed. The air-to-air mode is used for research and development projects and then only with special permission. Required information is listed below for each case.

6.1.4.1 Air-to-Ground. Determine desired flight profiles. Flight information necessary to perform an evaluation is altitudes, ranges, and directions of the aircraft relative to the target during laser operations. Various terms are used to describe the aircraft direction during ordnance delivery; they include approach track, attack heading, and run-in heading. These headings can be on a single bearing, a range of bearings, and unrestricted approach (360°). Typical mission profiles are

Toss Delivery, General Profile

Slant Range: 1,800 - 70,000 feet

Altitude: 200 - 2,600 feet

Toss Delivery, Mode A

Slant range: 20,000 - 70,000 feet

Altitude: 200 - 320 feet

Toss Delivery, Mode B

Slant range: 10,000 - 25,000 feet

Altitude: 1,000 - 3,400 feet

Straight and Level Delivery

Slant range: 1,800 - 30,000 feet
Altitude: 1,500 - 3,300 feet

Dive Delivery

Slant range: 8,500 - 14,000 feet
Altitude: 4,000 - 7,600 feet

6.1.4.2 Ground-to-Ground. Determine possible laser locations and direction of laser operations.

6.1.4.3 Ship-to-Target. Determine the possible laser locations, direction of laser operations, and ship headings.

6.1.5 Laser Surface Danger Zone. The LSDZ (also called the buffered laser footprint for airborne and elevated lasers) must be determined using the procedures provided in Paragraphs 6.3, 6.5, 6.7, 6.8, and 6.9.

6.2 Target and Target Area Condition

Careful attention must be paid to the condition of the target and surrounding laser hazard area. Any specular reflectors on or around the laser targets must be either removed or rendered diffuse. Specular reflectors may be rendered diffuse by painting with a flat (non-specularly reflecting) paint. Merely covering a specular reflector is not adequate, because the covering material is usually susceptible to ordnance damage. The position and orientation of any specular reflectors that cannot be removed or rendered diffuse must be noted, so they can be considered during the laser safety evaluation. Generally, specular reflectors larger than .05 inch in diameter must be removed from the LSDZ. If this is too restrictive, individual LSOs may refer to the specialists in subparagraph 1.2.2. Target area conditions should be reviewed periodically as determined necessary by local safety authority.

6.3 System Performance

To meet mission requirements, the stability, pointing accuracy, and boresight retention capabilities of a laser rangefinder and designator system must exceed those required for range safety. Described in the following subparagraphs are buffer zones and laser variety.

6.3.1 Buffer Zones. In establishing the laser safety buffer zone for a particular system, a factor of at least five times the demonstrated accuracy of the system is used. This factor has been used to compensate for such factors as untrained operators, adverse environmental factors, and system use at the limits of its capability. These buffer zones for specific systems are addressed in Appendix A, Table A-1.

6.3.2 Laser Variety. If a variety of laser systems with similar capabilities is to be used on the same range, only the worst-case parameters are used in the laser safety evaluation of the range. As an example, the A-6E Target Recognition Attack Multisensor (TRAM), the OV-10D Night Observation System (NOS), and the F-111 Pave Tack systems have similar performance capabilities and may be considered for use on the same range facility. The NOHDs of the systems, as measured in the far field, are 8.1 nautical miles (nmi), 6.1 nmi, and 8.6 nmi. All three systems have been assigned a safety buffer zone of 5 mrad. A range safety evaluation based on an NOHD of 8.6 nmi and a 5-mrad buffer zone would, therefore, allow safe use of any one of the three systems on the range without the confusion of three different sets of restrictions. The system parameters are also adequately similar so the least hazardous systems are not unduly restricted.

6.4 Laser Surface Danger Zone

The LSDZ consists of the target area plus the horizontal and vertical buffer zones (see Figure 6.2) and considers both direct hazards (main beam) and indirect hazards (reflections). The boundaries of the LSDZ depend on which of the two overlapping zones, direct hazard or the indirect hazard, is larger. If there are no specular reflectors on the range and the laser is not a diffuse reflection hazard, there will not be an indirect hazard zone. The direct hazard zone will always exist if laser-to-target distance is less than the NOHD. The LSDZ includes the laser beam plus a buffer zone around the beam to account for laser platform instability. The three types of LSDZs and the dimensions are described in the following subparagraphs.

6.4.1 The total hazard zone is LSDZ area Z or simply the LSDZ. It extends out to the NOHD/NOHD-O or beam backstop and the edges of the laser beam buffer zone.

6.4.2 The area that must be cleared of specular surfaces is LSDZ area S. For ground based lasers that do not project a well defined footprint on the ground around the target (beam and buffer footprint are contained on target), LSDZ area S is usually defined by a circle of radius s (as specified in Appendix A, Table A-1) around the target. For airborne laser operations, area S is the same as LSDZ area Z. For ground based laser operations from elevated platforms where the laser projects a well defined buffer footprint, area S should equal LSDZ area Z. Backstop areas where the energy of the incident beam is capable of producing a specular reflection hazard are considered LSDZ area S.

6.4.3 The diffuse reflection hazard zone is LSDZ area T. It extends to distance t , the diffuse reflection hazard distance, and will only be present for lasers capable of producing a hazardous diffuse reflection which have a distance t associated with them. The LSDZ area T is considered an exclusion zone. No one is allowed in it, and firing lasers at any materials located within this diffuse reflection hazard area must be prohibited. Although a skin hazard can also exist in this area, it is a minor concern compared to the diffuse reflection hazard (see Figure 6-3).

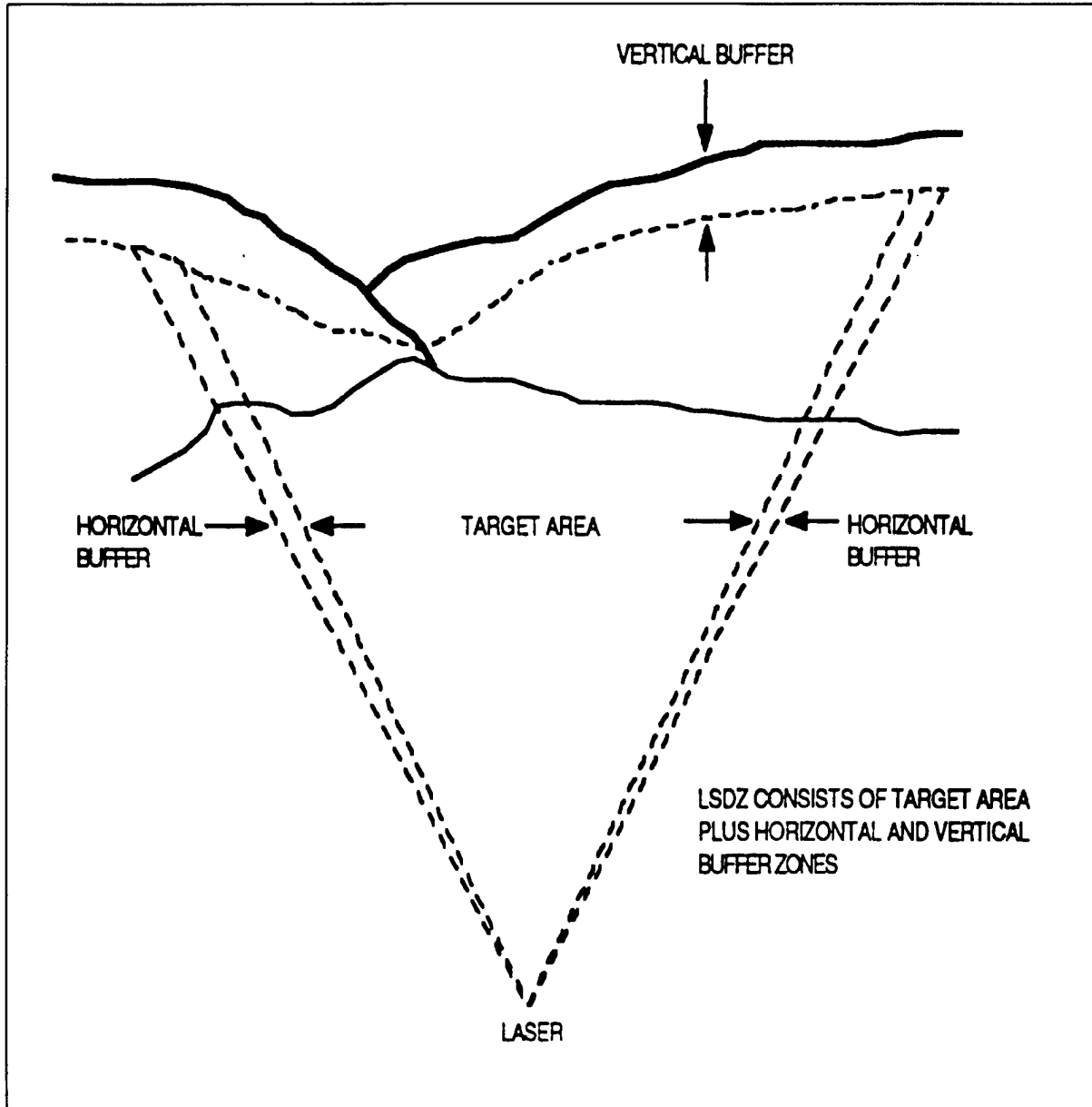

Figure 6-2. Laser surface danger zone.

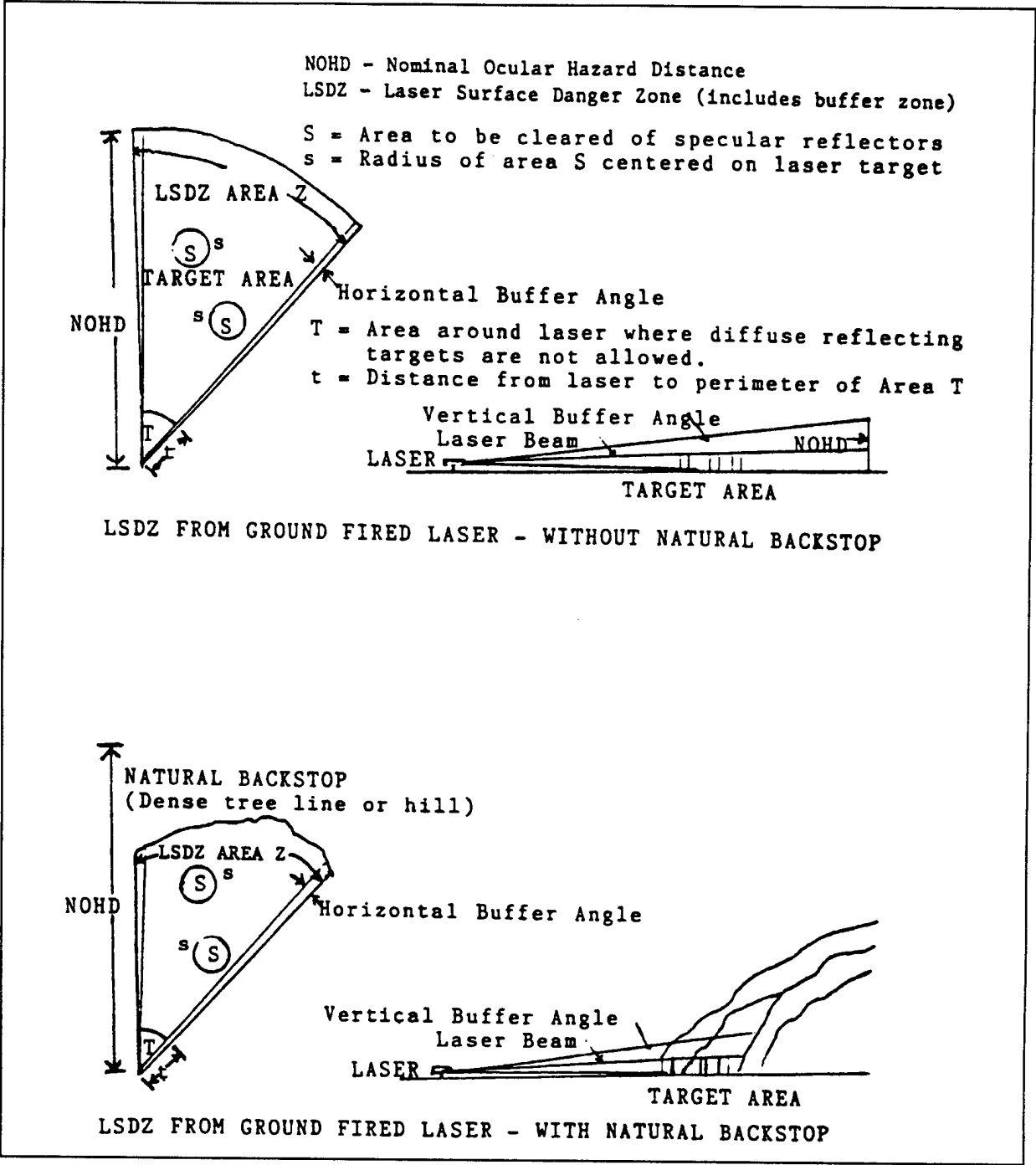

Figure 6-3. LSDZ without and with natural backstop.

6.4.4 The tables in appendixes A, B, and C list the applicable dimensions of the hazard distances for current laser devices. Figure 6-4 provides an example of an LSDZ or laser range danger fan (LRDF) for a training situation. The following paragraphs describe the LSDZ limits.

6.4.4.1 Existing Surface Danger Zones. Existing munitions surface danger zones for direct fire weapons are usually large enough to provide the required horizontal and vertical buffer zones for ground-to-ground laser operations provided the beam is terminated in the impact area (see Figures 6-5 and 6-6).

6.4.4.2 Distance of the Laser Surface Danger Zone. The following combination of NOHD and terrain features must be considered in controlling laser hazards.

6.4.4.2.1 When viewing the collimated beam with a telescope, the hazardous range is greatly increased. For example, a 10-km NOHD would be increased to 80 km for an individual looking back at the laser from within the beam with 13 power optics. Such large amounts of real estate are difficult to control. The solution is to use a backstop behind the target.

6.4.4.2.2 On the ground, this area normally extends to an adequate backstop or the NOHD. Laser operations at targets on the horizon is permitted as long as air space is controlled to the NOHD. In this case, the LSDZ extends downrange to the NOHD in the airspace and to the skyline on the ground as seen from the laser position (see Figure 6-6). Operators and crews will conduct laser operations only at approved targets. Usually, when there are no natural backstops available (for example, mountains), the magnified NOHD-O (O indicates optics) may extend out to extremely long ranges (for instance, 80 km for tank-mounted laser rangefinder (LRF)). This extreme situation would only create ocular hazards if (1) there was a direct LOS to an observer on the ground, and (2) there is a possibility that the observer could be engaged in direct intrabeam viewing with unfiltered magnifying optics.

6.4.4.2.3 Unless the NOHD or NOHD-O has been exceeded, the hazard distance of the laser device is the distance to the backstop. This hazard distance must be controlled. The terrain profile from the laser device's field of view plays a very important role, because the laser presents only a LOS hazard. The optimal use of natural backstops is the obvious key of minimizing laser range control problems.

EXAMPLE

M60A3 WITH STABILIZATION AND LASER RANGEFINDER FIRING THE MAIN GUN WHILE MOVING. IN THE COMMANDER'S JUDGEMENT, THE POSSIBILITY OF AN OBSERVER WITH MAGNIFYING OPTICS OBSERVING THE OPERATING LASER ON THE TANK FROM A DISTANT GROUND POSITION BEYOND THE NOHD IS VERY REMOTE. THE AIRSPACE DOWNRANGE IS RESTRICTED OUT TO 10 KILOMETERS.

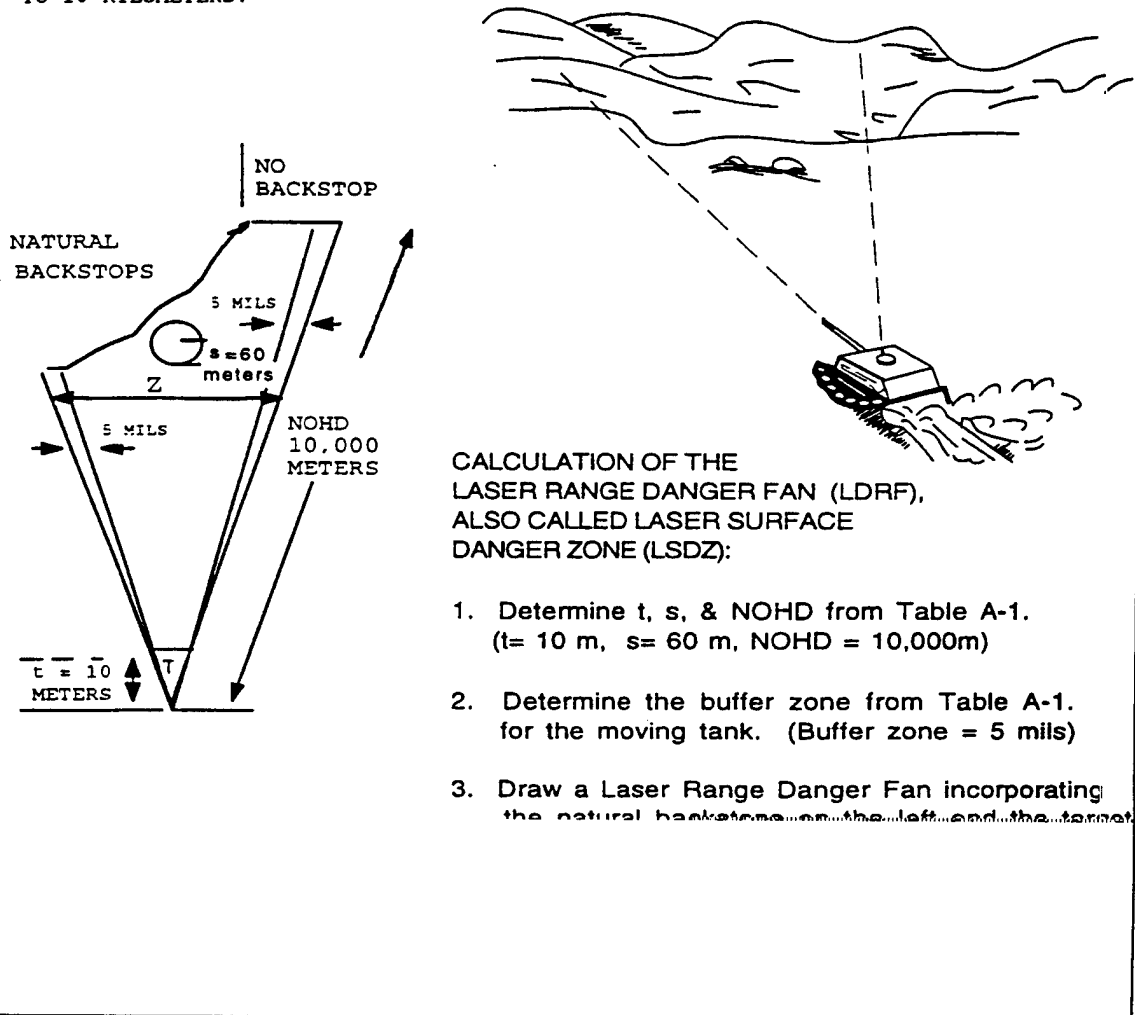

Figure 6.4. Example laser range danger fan/laser surface danger zone.

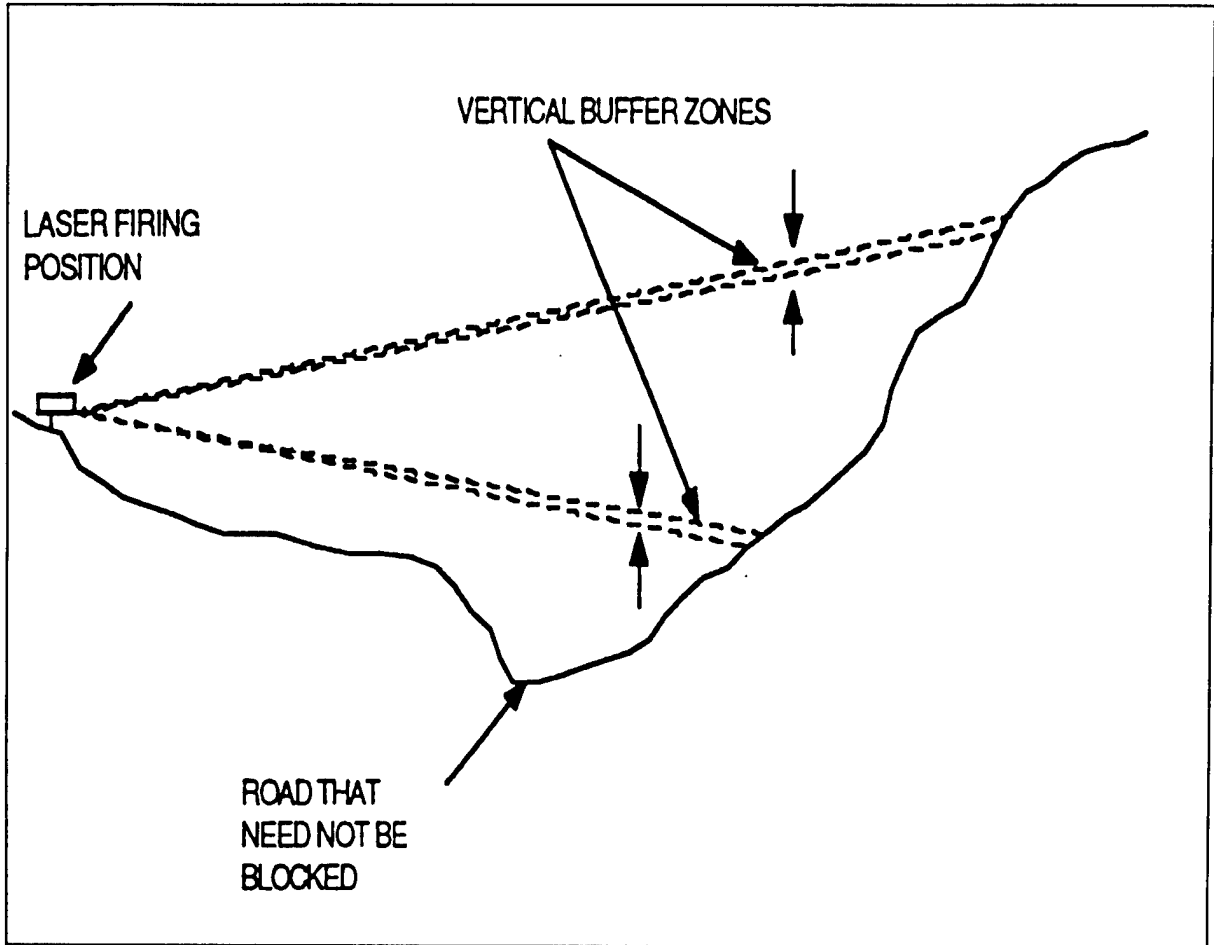

Figure 6-5. Vertical buffer zone.

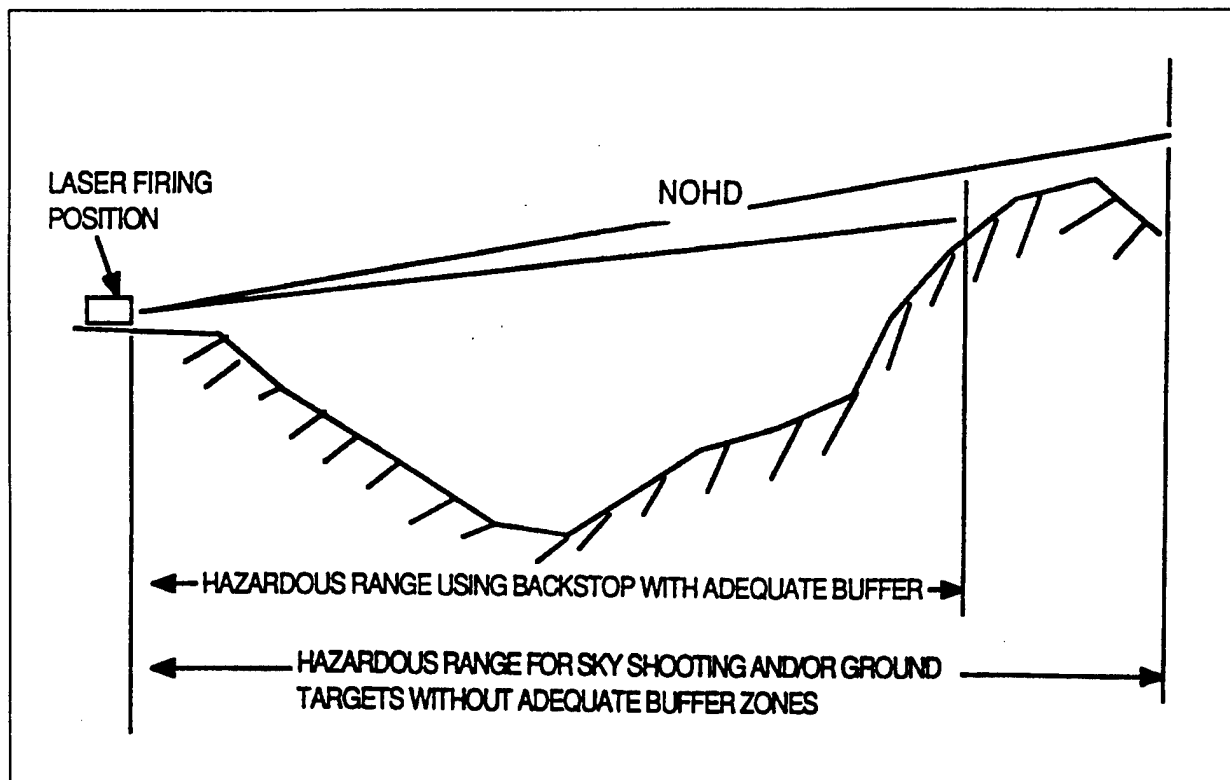

Figure 6.6. Effects of backstops.

6.4.4.3 Buffer Zones. The extent of horizontal and vertical buffer zones around the target area, as viewed from the firing area, depends on the aiming accuracy and stability of the laser device. The laser horizontal buffer zones could partially or completely be included in lateral safety or ricochet areas on ranges where the laser is used with live fire weapons. Table A-1, lists buffer zone values for currently fielded equipment.

6.5 Range Facilities Evaluation

6.5.1 Range Location and Access. Range facilities are evaluated in terms of location relative to populated areas, military and civilian industrial sites, and water surface traffic. The methods used to control access to the potential laser hazard area, that is, fences, warning signs, airspace restrictions, and water surface danger areas, must be evaluated for adequacy. The locations of all occupied areas on the range such as control towers must be determined as well as specific environmental factors like the habitat of any endangered wildlife in the range area.

6.5.2 Targets Types. Target areas are evaluated for types of targets currently in position. Vehicular targets, in particular, could have chrome bumpers, windshields, or other flat glass or chrome surfaces. Presence of these types of surfaces could generate a specular reflection when

optical radiation is incident to the target. This hazard could even exist if the surfaces were bent or broken because of previous ordnance impacts or explosions. Broken or bent specular surfaces could still have an adequately large flat surface remaining to generate a specular reflection. Unexploded ordnance areas in or surrounding the proposed target area could have an impact on the advisability of policing or masking existing specular surfaces.

6.5.3 Terrain Features. Terrain features on and surrounding the range are evaluated for impact on laser safety. Usable terrain and vegetation backstops are identified and located on maps of the range area. Any mountain peaks outside the range are examined to verify that such obstructions as radio or television towers or park service observation towers do not extend into the laser buffer zone between the laser and the target. This consideration only affect airborne laser systems when active target illumination begins before the aircraft enters the range boundaries.

6.5.4 Access Control. Roads or other access points to the range area should be evaluated to determine the probabilities of non-controlled personnel entering the target area or controlled range areas. Roadblocks should be established and posted at the area where access could occur.

6.5.5 Operations Over Water. Because water can become a flat specular reflector when it is calm, additional precautions are required when firing the laser over water. In most applications, the reflectors contained in Table 6-1 can be either covered or removed, while water cannot always be avoided; therefore, additional precautions are required when firing over water as discussed in Appendix G (see Figure 6-7).

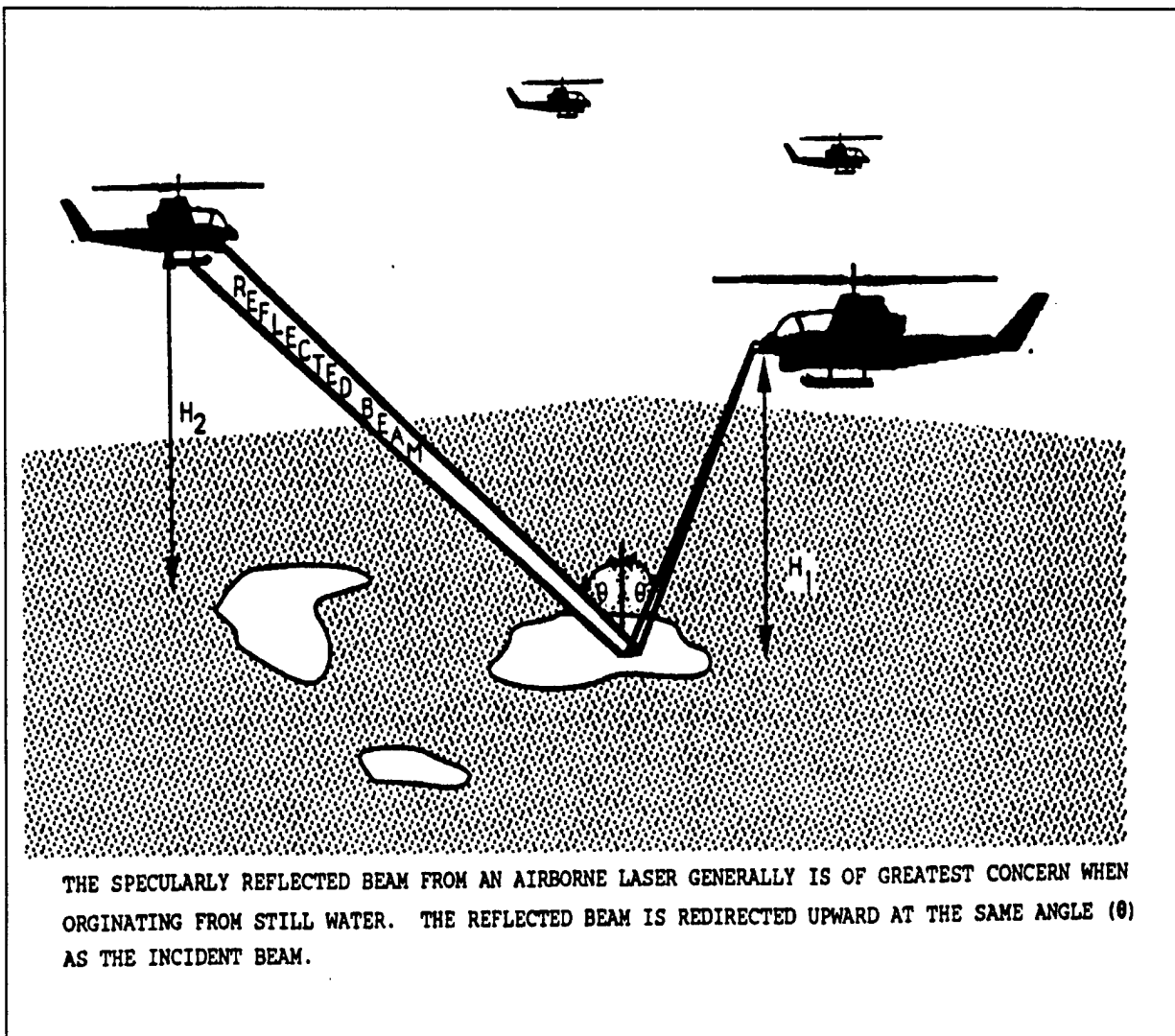

Figure 6-7. Example of airborne beam reflection.

6.6 Visual Survey

A visual survey of the range area is often very useful. The survey should be conducted from actual firing locations and target locations. If the target is used for aerial operations, the range evaluator should, whenever possible, perform an aerial fly-over on the proposed or approved laser run-in headings. A pair of binoculars with an angular calibrated reticle can be used to scan the terrain features to estimate the natural buffer area. Suitable areas should be marked on a current map. Do not rely entirely upon the contour lines on the range map, because they may result in an erroneous estimation of the buffer area. Actual targets should be visually inspected for specular reflectors before their insertion on the range to ensure that these surfaces are removed. Conversion of an impact area to a laser range area may require overflights to observe any glints of sunlight reflecting from broken bits of glass or other reflectors laying on the ground.

6.7 Laser Parameters

Laser system parameters may vary greatly with laser location, look angle, support structure and laser characteristics. The effects of these parameters are provided in the following subparagraphs.

6.7.1 In addition to knowing the geometry of the range environment, knowledge of the specific laser system is essential. Perhaps the most important aspect to laser range safety is the assurance that the laser beam is terminated within a controlled area. When the distance to the backstop is less than the NOHD, the backstop determines the absolute hazard distance and the NOHD is of academic value. The buffer zone requirements are based on the pointing accuracy and stability of the system and, therefore, are dependent upon the laser system mounting; that is, a handheld laser system has a larger buffer zone than a tripod mounted system. Some laser systems are designed to be used from a variety of mounting configurations. Table A-1 contains the minimum buffer zone requirements for currently fielded laser systems under their intended mounting configurations.

6.7.2 A controlled area is where the occupancy and activity of those within the area are subject to control and supervision for the purpose of protection from laser radiation hazards. The hazard zone or footprint will be the beam itself plus a buffer zone. This footprint is normally an ellipse. The minor axis depends on the laser-to-target range and the buffer zone angle for that particular laser. The major axis depends upon the altitude of the laser above the target in addition to the requirements for the minor axis. Therefore, the amount of and surface area required to be controlled depends on the elevation of the laser, range to target, and the specific laser system. When necessary, any of these factors can be changed to ensure that the laser beam is terminated within the controlled range boundary; that is, the footprint can be reduced in size by elevating the laser. Thus, either a fairly large area can be controlled which might extend out to the NOHD, or target or laser locations can be selected which provide the required backstop.

6.8 Laser Footprint

Calculate the size of the beam which irradiates the ground or ground-based, sea-based, or airborne target (footprint). Normally, laser beams are circular, diverge equally in all directions, and produce cone shaped beams. The size of the beam depends on the initial beam diameter, divergence, and distance (slant range) from the source. The size of the footprint is the size of the beam plus a buffer zone (see Figure 6.8). For scanning systems, the size of the beam would include all positions in the scan. The shape of the footprint depends on the angle of the beam that intersects the ground. (Slant angle is determined from the range and altitude.) The footprint is determined by buffer angle and size which are described in the following subparagraphs.

6.8.1 Buffer Angle. If the assigned laser buffer angle is 5 milliradians and the beam divergence is less than 0.5 milliradians, use 5 milliradians for the buffered footprint angular width and ignore the beam divergence. This approach will only introduce an error of less than 5 percent. If this evaluation is overly restrictive (requires too much land), a system specific evaluation can be made for each laser system. The appropriate buffer angles for most systems are listed in Appendix A. To calculate a buffered footprint for other systems when the beam divergence is equal to or greater than 1 milliradian, the footprint will be the buffer angle plus the beam divergence. When the beam divergence is less than 1 milliradian, the following will apply:

6.8.1.1 If the aiming accuracy for a stabilized laser is unknown, buffered footprint angular width will be 5 milliradians either side of the beam.

6.8.1.2 If the aiming accuracy is known, the buffered footprint angular width will be 5 milliradians, or the absolute value of the aiming uncertainty (in milliradians) plus 5 times the beam divergence at the $1/e$ (.3679) point, whichever is less, either side of the laser beam. Aiming accuracy should be contained in the system specifications.

6.8.2 Footprint Size. There are at least two approaches used to determine the size of the footprint. If the desired flight profiles are known, then the size of the footprint can be determined from these flight profiles. If the size of the range is the limiting factor, the boundaries of flight profiles can be determined which would keep the footprint within the range. These two approaches can be used independently or, typically, used together to maximize land use and minimize mission impact. The procedures for these two approaches are detailed in Appendix E.

6.9 Other Considerations

6.9.1 Moving Targets or Lasers. A moving target or laser will affect the size of the LSDZ and may indicate that the single pulse NOHD is more applicable than the multiple pulse NOHD, especially when evaluating specular reflections. This range layout must be decided on a case-by-case basis. A common application includes evaluating reflection hazards when the angle of laser operations is rapidly changing, and therefore, the probability of a multiple pulse exposure is small.

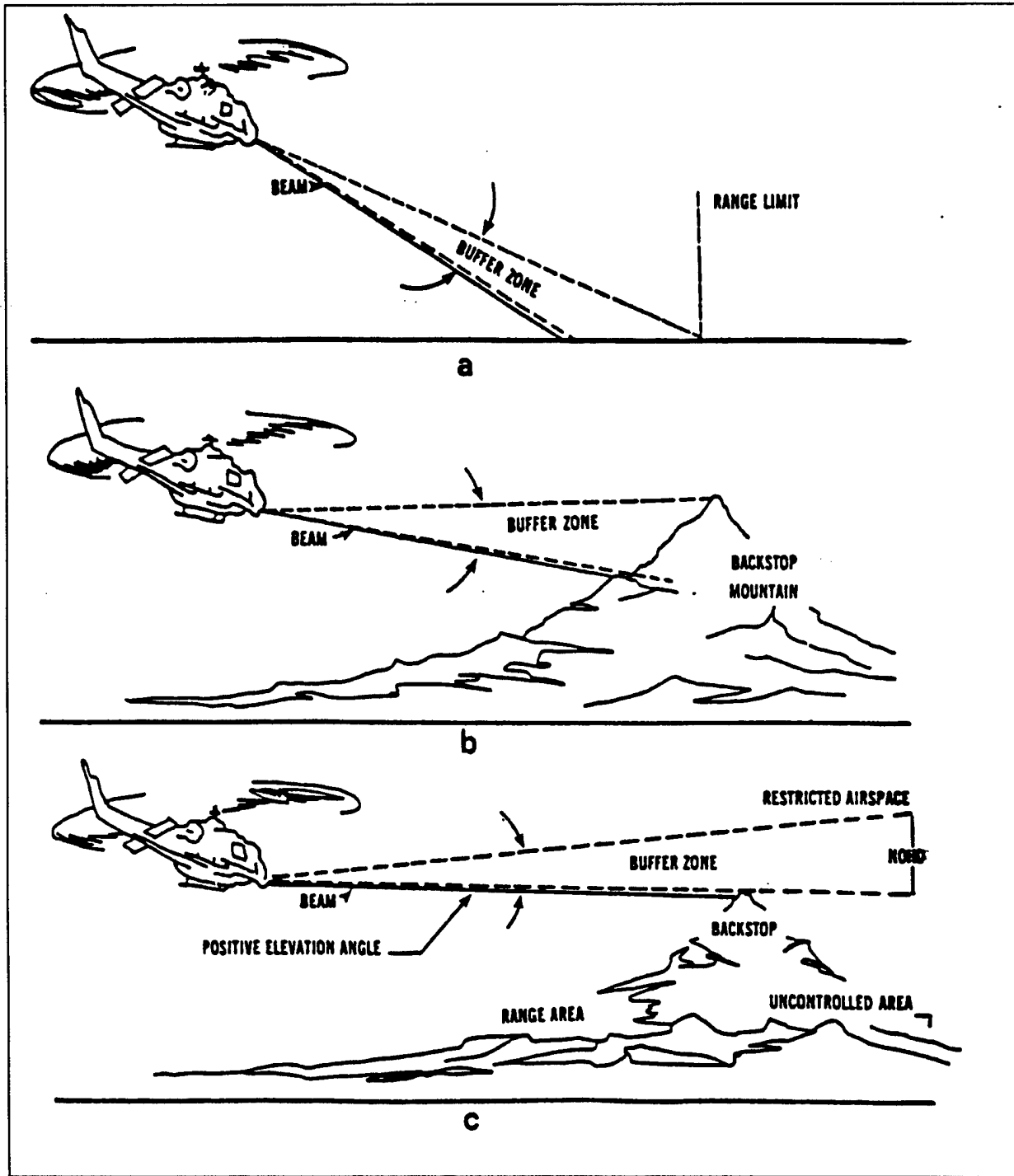

Figure 6-8. Examples of the use of natural backstops, buffer zones, and restricted air space.

6.9.2 Operating Outside of Controlled Area. Targets should never be positioned outside the controlled area (including airspace). Airborne lasers should not be operated outside the controlled airspace if the potential for the beam striking an object outside the controlled area exists. If this risk is minimal, consider permitting laser operations from uncontrolled areas under controlled conditions. Ensure the regional Flight Service Center for the Federal Aviation Administration (FAA) and Coast Guard is notified before starting this operation, so they can publish a Notice to Airmen and Mariners. The FAA regulation governing this is 7930.2B, Notices to Airmen (NOTAM). Ground laser systems should never be operated outside the controlled area.

6.10 Range Control Procedures and Recommendations

Laser range safety shall prevent exposure of unprotected personnel from laser radiation in excess of the MPE. This objective can be met by determining where the laser radiation is expected to be, restricting access of unprotected personnel, and removing reflective surfaces from this area.

6.10.1 Target Areas. Recommended target areas are those without specular (mirror like) surfaces. Glossy foliage, raindrops, snow, and other natural objects are not considered to be specular surfaces that would create ocular hazards. Although snow is not considered to be a specular surface, if thawed and refrozen, hazardous reflections can be found, especially at low angles of incidence.

6.10.2 Sanitized Ranges. If the target areas have no flat specular surfaces, range control measures can be limited to the control of the area where the laser beam hits directly.

6.10.3 Laser Operation. Laser devices shall only be directed at safety approved targets and only from approved operating positions or on designated headings and altitudes.

6.10.4 Unprotected Personnel. Unprotected personnel must not be exposed to laser radiation greater than the MPE.

6.10.5 Warning Signs. Local procedures should provide for the placement of laser warning signs at the boundaries of the controlled areas and the access points. This process is normally coordinated between bioenvironmental engineers, industrial hygienists, laser safety officers, or ground safety, ship's safety officer, and the range officer. These signs should be constructed in accordance with MIL-STD-1425. They are also available in the federal stock system (see Figure 4-3). If the hazard zone is within a designated range, access controls must be established.

6.10.6 Eye Wear. Personnel within the LSDZ shall wear laser protective eye wear during laser operations. Eye wear must be approved for the wavelength of the laser system being used and must provide sufficient protection (see Appendix A, Tables A-3 and A-4). If more than one type of laser is used, protective eye wear must provide adequate protection for all wavelengths involved (OD greater or equal to the largest minimum OD required for each wavelength).

6.10.7 Optical Devices. Magnifying daylight optical devices, without attenuation, may be used to view the target only if flat specular surfaces have been removed from the target area. Specular surfaces can be viewed only if appropriate laser safety filters are placed in the optical train of the magnifying optics.

6.10.8 Range Access Restrictions. Access restrictions to the laser range should include consideration of road blocks or gates especially where the range is unmanned.

6.10.9 Laser Demonstrations. Personnel may safely view a diffuse reflection of an otherwise hazardous laser beam from a protected setting as shown on Figure 6-9. The laser-to-target distance is great enough to preclude a hazardous reflection from a dry diffuse target. Infrared viewers or night vision goggles are necessary to view the diffuse reflections from near-infrared lasers. Visible diffuse reflections can be seen with the unaided eye.

LASER TRAINING RANGE

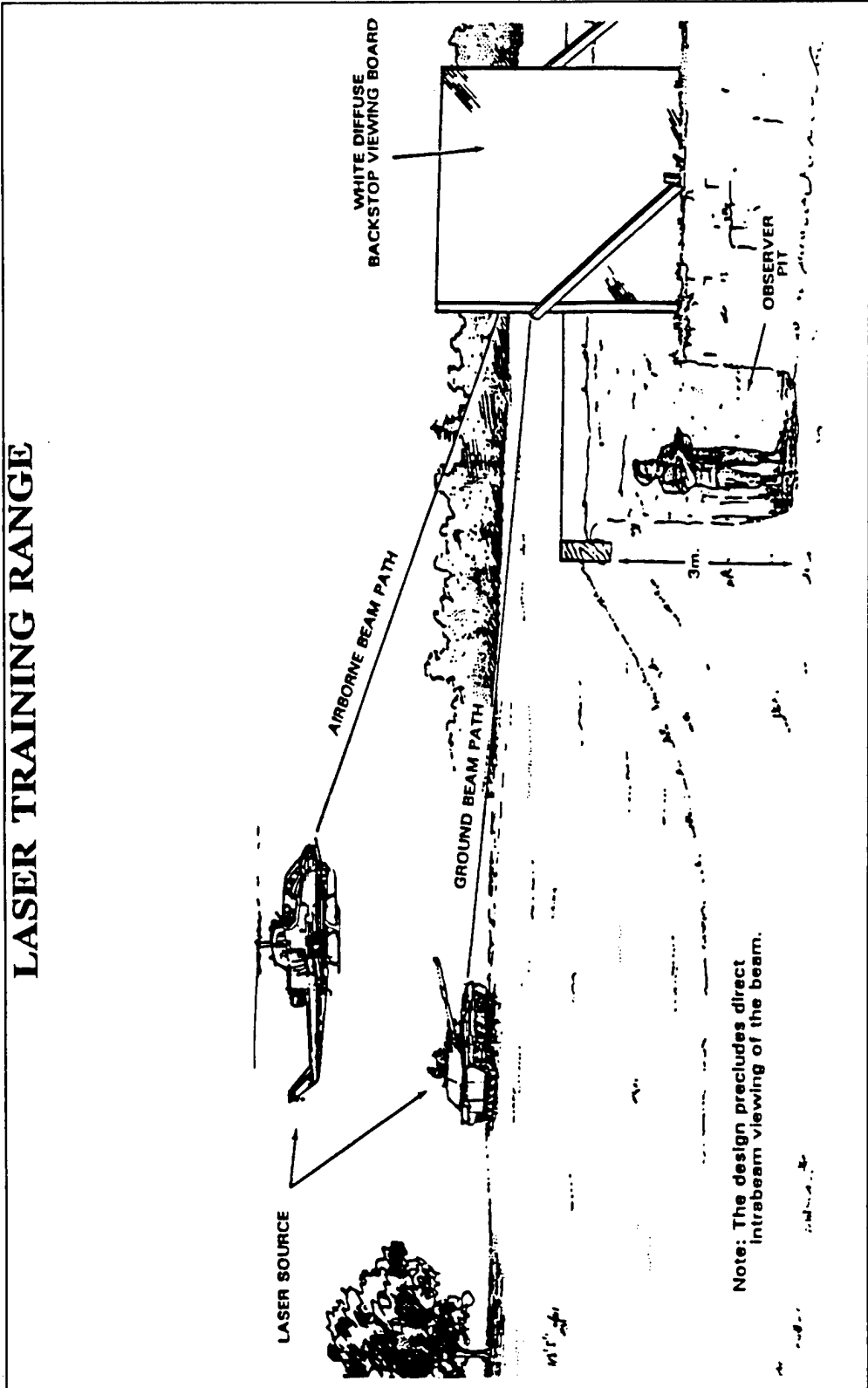

Figure 6-9. Supervised laser demonstration for military training.
(Modified from ANSI Z136.1, Figure 2D)

CHAPTER 7

USER LEVEL LASER INSTRUCTIONS

7.1 Instruction

Using the laser range safety evaluation, the range planner/LSO will determine the necessary information to

- 7.1.1 prepare or modify range laser safety directives,
- 7.1.2 develop SOP for laser operations,
- 7.1.3 brief personnel involved in laser operations to provide an understanding of the hazards of specific devices and to allay unfounded fears, and
- 7.1.4 prescribe the personal protective equipment to be used.

7.2 Directives

The laser range safety evaluation should be used to review and to ensure overall range safety regulations are current. Regulations should be developed or updated as necessary to take into account new laser systems, operating areas, and targets.

7.3 Standard Operating Procedures

The SOPs for specific laser devices should inform laser users of the potential hazards from the laser devices under their control during laser operation. Checklists for evaluating SOP are provided in Appendix F. An SOP should be prepared concerning procedures for a presweep of the range before a laser operation to ensure unprotected personnel are not in the target area and to maintain radio communications.

7.4 Safety Briefing

In addition to instructions on particular devices or simulators, training material required for classroom instructors and range personnel should include.

- 7.4.1 principles of reflection or refraction of light,
- 7.4.2 hazards of laser beams to humans and misconceptions about laser effects,
- 7.4.3 safety standards or operational control procedures, and

7.4.4 preparation of range areas for laser use (that is, ensure personnel have been alerted to the laser hazard and have covered, removed, or avoided the firing at specular surfaces).

7.5 Protective Equipment

Eye protection requirements are listed in Appendix A, Table A-3.

7.6 Systems Briefings

Laser indoctrination should be provided at the same time as the basic weapons systems instruction to students taking advanced individual training and to officers taking basic courses. The classroom instructors must be knowledgeable in operator and crew aspects of laser safety. Reference publications on subject lasers should be readily available. The instruction presented should be at the user level. (Complex scientific data or terminology should be avoided.) A training film, if available, should be included in the instruction program. Hazard data for lasers as incorporated into the technical manual on the related weapon system or on the laser component should be stressed. Proper channels for obtaining professional safety and medical assistance should be addressed during indoctrination.

APPENDIX A

**LASER SAFETY INFORMATION
FOR FIRE CONTROL LASER SYSTEMS**

APPENDIX A

LASER SAFETY INFORMATION FOR FIRE CONTROL LASER SYSTEMS

1.0 Scope

This appendix provides safety information for currently fielded laser fire control systems.

2.0 Fire Control Laser Safety Features

Fire control laser systems are laser rangefinders (LRFs) and laser designators (LDs). These laser systems can be far more harmful to the eye than laser training devices such as MILES and Air-to-Ground Engagement System/Air Defense (AGES/AD) laser simulators. Consequently, fire control lasers require control measures to prevent permanent blindness to an unprotected individual viewing the laser system from within the laser beam. A sample list of control measures for operators of fire control lasers is provided in Appendix H.

2.1 Ruby LRFs. The ruby LRFs on the tanks are the most hazardous lasers to the eye at close range. These lasers not only pose a hazard while viewing the laser from within the direct beam, but also from viewing the diffusely reflected laser radiation. The distance t is from the laser within the laser beam path in which there is both a skin hazard and diffuse reflection hazard. Distance t represents the range to be cleared in front of the tank.

2.2 Distance S . The distance s was established to prevent specular or collimated reflections from flat glass and other flat and smooth surfaces which might leave the controlled range area. This is the radial distance away from targets out to which flat specular reflectors must be cleared. For fixed wing aircraft, the entire buffered laser footprint must be cleared of specular reflectors. A specular reflector is one that is so smooth that a person can see an image in it. A curved specular reflector does not create a significant risk to individuals at typical training distances from a target.

2.3 Current Laser Safety Summary. Tables A-1 and A-2 summarize current laser safety information pertaining to the most common fire control laser systems likely to be encountered. The NOHD for unaided viewing and while viewing the beam through an optical instrument such as a pair of binoculars (NOHD-O), are listed in Table A-1. The importance of NOHD is often overvalued, because the laser beam is normally required to be terminated in a controlled area and the distance to the backstop defines the absolute hazard distance.

TABLE A-1. NOHD (ATMOSPHERIC ATTENUATED) AND RANGE SAFETY INFORMATION FOR FIELDED MILITARY LASER SYSTEMS

Device/Mounting	NOHD		NOHD-O			REFLECTOR CLEARANCE		BUFFER ZONES (Buffer Angle) (Each Side)	
	Multi-Pulse (Kilometers)	Single Pulse (Kilometers)	7X50 Binoc. (Kilometers)	8 cm Optics (Kilometers)	12 cm Optics (Kilometers)	t ¹	s ²	Static	Moving
						(Meters)			
<u>TANK MOUNTED</u>									
AN/VVG-1 (M551A1)	9	9	32	47	67	10	60	2	Not allowed
AN/VVS-1 (M60A2)	9	9	32	36	44	10	100	5	10
AN/VVG-2 (M60A3)	8	8	30	40	47	10	60	2	5
red ESSLR (29dB)	0.3	0.3	1.8			0	Target	2	5
green ESSLR (55dB)	0	0	0	0	0	0	0	NA	NA
AN/VVG-3 (M1Tank)	7	7	25	35	44	0	60	2	5
ESSLR	0	0	0	0	0	0	0	NA	NA
AVENGER		0	0	0	0	0			
LAV-105		8.2	32	41	50	0	60	2	5
LAV-AD		0	0	0	0	0			
<u>MAN PORTABLE</u>									
AN/GAQ-T1 (LD82LB LDSS)	12.5	-	-	43	52	0	200	5	NA
AN/GVS-5 (Handheld)	2.7	2.7	13	21	27	0	200	10	NA
19dB red filter	0.29	0.29	1.8	1.8	-	0	200	10	NA
29dB yell. filt	0.056	0.056	0.55	0.55	-	0	200	10	NA

¹ t = distance from the laser in the laser beam path in which there is both a skin hazard and diffuse reflection hazard. Represents the range to be cleared in front of the tank.

² s = distance around the target out to which specular reflectors must be cleared when laser is level or nearly level with target.

TABLE A-1. NOHD (ATMOSPHERIC ATTENUATED) AND RANGE SAFETY INFORMATION FOR FIELDIED MILITARY LASER SYSTEMS (continued)

Device/Mounting	NOHD		NOHD-O			REFLECTOR CLEARANCE		BUFFER ZONES (Buffer Angle) (Each Side)	
	Multi-Pulse (Kilometers)	Single Pulse (Kilometers)	7X50 Binoc. (Kilometers)	8 cm Optics (Kilometers)	12 cm Optics	t ¹	s ²	Static	Moving
<u>MAN PORTABLE</u>									
AN/PAQ-1 (Handheld LTD)	7	3.5	15	33	-	0	200	10	NA
AN/PAQ-3 MULE (Tripod)									
Designator-Day	20	12	53	64	78	0	60	2	NA
Designator-Night	20	12	53	64	78	0	150	5	NA
RangeFinder-Day	12	12	37	47	-	0	60	2	NA
Rangefinder-Night	12	12	37	47	-	0	150	5	NA
Rangefinder with 12dB filter	3.3	3.3	16	-	-	0	60	2	NA
AN/PAQ-3 MULE (Handheld)									
Designator-Day	20	12	53	64	78	0	200	10	NA
Designator-Night	20	12	53	64	78	0	300	15	NA
Rangefinder-Day	12	12	37	47	-	0	200	10	NA
Rangefinder-Night	12	12	37	47	-	0	300	15	NA
AN/PAQ-4/A/B/C IR Aiming Light	0		0	0	0	0	0	0	0 A
AN/PEQ-1 (SOFLAM)	9.6	-	35	45	54	0	200	10	NA

¹ t = distance from the laser in the laser beam path in which there is both a skin hazard and diffuse reflection hazard. Range to be cleared in front of the laser.

² s = distance around the target out to which specular reflectors must be cleared when laser is level or nearly level with target.

TABLE A-1. NOHD (ATMOSPHERIC ATTENUATED) AND RANGE SAFETY INFORMATION FOR FIELDED MILITARY LASER SYSTEMS (continued)

Device/Mounting	NOHD		NOHD-O			REFLECTOR CLEARANCE		BUFFER ZONES (Buffer Angle) (Each Side)	
	Multi-Pulse (Kilometers)	Single Pulse (Kilometers)	7X50 Binoc. (Kilometers)	8 cm Optics (Kilometers)	12 cm Optics	t ¹	s ²	Static	Moving
<u>MAN PORTABLE</u>									
AN/PEQ-2 (ITPIAL)									
Aim light and Illuminator	0.263	-	1.8	2.8	4.7	0	20	10	NA
Illuminator only	0.211	-	1.5	2.3	3.9	0	20	10	NA
Aim Light (High)	0.078	-	0.56	0.88	1.5	0	20	10	NA
Aim Light (Low)	0	-	0	0	0	0	0	0	NA
AN/PVS-6 (MELIOS)	0	-	0	0	0	0	0	0	0
AN/PVS-X MLRF									
Mini-Laser Rangefinder	-	3	16	29	-	0	200	90 ^{o3}	
AN/TVQ-2 GVLLD (Tripod)									
Designator	25	17	63	80	87	0	60	2	NA
Rangefinder	8	8	28.5	40	-	0	60	2	NA
Rangefinder with 8.5dB yell.filter	3.1	3.1	15	23	-	0	100	2	NA
CLD (Compact Laser Designator)	9.7	-	38	48	58	0	200	10	NA
LLTD	7	-	15	38	-	0	200	10	NA

¹ t = distance from the laser in the laser beam path in which there is both a skin hazard and diffuse reflection hazard. Range to be cleared in front of the laser.
² s = distance around the target out to which specular reflectors must be cleared when laser is level or nearly level with target.
³ 90° buffer zone required for RCA version AN/PVS-X with secondary beams.
10° buffer zone required for Brunswick version.

TABLE A-1. NOHD (ATMOSPHERIC ATTENUATED) AND RANGE SAFETY INFORMATION FOR FIELDDED MILITARY LASER SYSTEMS (continued)

Device/Mounting	NOHD		NOHD-O			REFLECTOR CLEARANCE		BUFFER ZONES (Buffer Angle) (Each Side)	
	Multi-Pulse (Kilometers)	Single Pulse (Kilometers)	7X50 Binoc. (Kilometers)	8 cm Optics (Kilometers)	12 cm Optics (Kilometers)	t ¹	s ²	Static	Moving
<u>AIRCRAFT MOUNTED LASERS</u>									
AH-1W Night Targeting System (NTS)	15	9.2	48	59	69	0	100	5	5
AN/AAS-33A (A-6E TRAM)	14.6	9	-	58	67	0	N/A	N/A	5
AN/AAS-37 (OV-10D NOS)	11.2	7.1	45	56	59	35	N/A	N/A	5
AN/AAS-38A (F/A-18)	17	10	50	63	73	0	N/A	N/A	5
AN/ASQ-153 (F-4E PAVE SPIKE)	10	6.8	-	48	58	0	N/A	N/A	5
AN/AVQ-25 (F-111F PAVE TACK)	16	8.8	-	52	70	0	N/A	N/A	5
F-117 (unattenuated)	18.5	9.5	130	-	-	0	N/A	N/A	TBD
LAAT (AH1F)	5	3.4	15	30	36	0	100	5	5
LANTIRN (Combat mode)	15	11.6	48	59	68	0	N/A	N/A	5 ³
(Training mode)	0	0	0	-	-	0	0	N/A	N/A
(Secondary Beam)	Maintain 1000 ft separation from other aircraft.								

¹ t = distance from the laser in the laser beam path in which there is both a skin hazard and diffuse reflection hazard. Range to be cleared in front of the laser.

² s = distance around the target out to which specular reflectors must be cleared when laser is level or nearly level with target.

³ Air Force assigned buffer zone is 2 milliradians for LANTIRN. It is general policy for this document that aircraft be assigned a minimum buffer zone of 5 milliradians.

TABLE A-1. NOHD (ATMOSPHERIC ATTENUATED) AND RANGE SAFETY INFORMATION FOR FIELDIED MILITARY LASER SYSTEMS (continued)

Device/Mounting	NOHD		NOHD-O			REFLECTOR CLEARANCE		BUFFER ZONES (Buffer Angle) (Each Side)	
	Multi-Pulse (Kilometers)	Single Pulse (Kilometers)	7X50 Binoc. (Kilometers)	8 cm Optics (Kilometers)	12 cm Optics (Kilometers)	t ¹	s ²	Static	Moving
						Diffuse (Meters)	Specular (Meters)	Milliradians	Milliradians
<u>AIRCRAFT MOUNTED LASERS</u>									
MMS (OH-58D)	35	23	56	-	-	0	100	5	5
NITE EAGLE (UH-1N)	15	11	45	55	65	0	100	5	5
PAVE SPECTRE	8.9	5	63	-	-	0	N/A	N/A	
TADS (Apache)	26	16	45	68	-	0	100	5	5
UH-1N Navigational Thermal Imaging System (AN/AAQ-22)	-	720	4.0	6.1	8.6	0	100	5	5
AC-130U LIA LTD/R (atten.=0) (atm atten.)									
TADS (Apache)	26	16	45	68	-	0	100	5	5
<u>SHIP MOUNTED LASERS</u>									
NMMS	0	0	0	0	0	0	0	0	0

¹ t = distance from the laser in the laser beam path in which there is both a skin hazard and diffuse reflection hazard. Range to be cleared in front of the laser.
² s = distance around the target out to which specular reflectors must be cleared when laser is level or nearly level with target.

TABLE A-2. NOHD (ATMOSPHERIC ATTENUATED) AND RANGE SAFETY INFORMATION FOR COMMERCIAL OFF-THE-SHELF (COTS) MILITARY LASERS*

Device/Mounting	NOHD		NOHD-O			REFLECTOR CLEARANCE		BUFFER ZONES (Buffer Angle) (Each Side)	
	Multi-Pulse (Kilometers)	Single Pulse	7X50 Binoc.	8 cm Optics (Kilometers)	12 cm Optics	t ¹	s ²	Static	Moving
<u>MAN PORTABLE</u>									
AIM-1/D	0.075	-	0.460	---	---	0	20	10	10
AIM-1/DLR	0.150	-	0.860	---	---	0	20	10	10
LPL-30	0.090	-	0.68	1.1	1.6	0	20	10	10
M-931	0.011	-	0.16	0.28	0.4	0	0	10	10
GCP-1 GCP-1A	0.090	-	0.68	1.1	1.6	0	0	35	35
NITE EYE	0.090	-	0.68	1.1	1.6	0	0	10	10
HAVIS M16 Aiming Light	0.012	-	0.1	0.17	0.25	0	0	10	10
TD-100/TD-100A	0.1	-	-	-	-	0	30	10	10
<u>AIRCRAFT MOUNTED LASERS</u>									
AIM-1/MLR	0.085	-	0.68	1.1	1.6	0	20	10	10
AIM-1/EXL	0.130	-	0.68	1.1	1.6	0	20	10	10

¹ t = distance from the laser in the laser beam path in which there is both a skin hazard and diffuse reflection hazard. Range to be cleared in front of the laser.

² s = distance around the target out to which specular reflectors must be cleared when laser is level or nearly level with target.

THIS HAZARD DATA COULD CHANGE, BECAUSE THE GOVERNMENT HAS NO CONTROL OVER THE MANUFACTURING OF THESE PRODUCTS. THE HAZARD CHARACTERISTICS IN THIS TABLE ARE VALID AS OF THE DATE OF THE GOVERNMENT EVALUATION. PERIODICALLY CHECK WITH THE MANUFACTURER TO ENSURE THE CHARACTERISTICS HAVE NOT CHANGED SINCE THE DATE OF THE LAST GOVERNMENT EVALUATION.

TABLE A-3. EYE PROTECTION REQUIREMENTS FOR FIELDED LASERS

Device/Mounting	Wavelength (Nanometers)	Built-in Safety Filter (OD)*	Required Eye Protection (Optical Density (OD))		
			Unaided	Aided	Other Aircraft
TANK MOUNTED					
AN/VVG-1 (M551a1)	694.3	clip-on 5	5.8	5.8	
AN/VVS-1 (M60A2)	694.3	clip-on 5	5.8	5.8	
AN/VVG-2 (M60A3)	694.3	clip-on 5	5.8	5.8	
AN/VVG-3 (M1)	1064	5	4.7	4.7	
AVENGER	10590		0	0	
LAV-AD	10600		0	0	
LAV-105	1064		4.0	4.7	
MAN PORTABLE					
AN/GAQ-T1 (LD82LB)	1064	YES	4.6	5.5	
AN/GVS-5	1064	5	3.7	4.4	
AN/PAQ-1 (LTD)	1064	4	4.2	5.8	
AN/PAQ-3 (MULE)	1064	5	3.9	5.6	
AN/PAQ-4/A/B/C	830		0	0	
AN/PEQ-1 (SOFLAM)	1064	5	4.0	5.3	
AN/PVS-6	1540		0	0	
AN/TVQ-2 (GVLLD)	1064	YES	3.8	5.5	
CLD (Compact Laser Designator)	1064	5	4.5	5.4	
LLTD	1064		4.0	4.9	
MLRF (Mini-Laser Rangefinder)	1064	YES	3.7	3.7	

* Assume that built-in safety filter only protects against the wavelength of the laser in which it is installed and that it does not always protect against other laser wavelengths.

TABLE A-3. EYE PROTECTION REQUIREMENTS FOR FIELDDED LASERS (continued)

Device/Mounting	Wavelength (Nanometers)	Built-in Safety Filter (OD)*	Required Eye Protection (Optical Density (OD))		
			Unaided	Aided	Other Aircraft
AIRCRAFT MOUNTED					
AC-130U LIA	807		2.7		
LTD/RF	1064		3.0		
AH-1W Night Targeting System (NTS)	1064	YES	3.5	5.2	
AN/AAQ-22 Navigational Thermal Imaging System	1064	N/A	4.0	4.0	
AN/AAS-33A(A-6E TRAM)	1064		4.6	5.8	3.0
AN/AAS-37 (OV-10D NOS)	1064		5.2	5.6	3.0
AN/AAS-38A (F/A-18)	1064		4.3	5.4	3.0
AN/ASQ-153 (F-4E PAVE SPIKE)	1064		4.2	5.6	
AN/AVQ-25 (F-111F PAVE TACK)	1064		4.3	5.8	
F-117	1064	N/A	4.5	6	
LAAT(AH-1F)	1064	YES	3.5	4.8	
LANTIRN (Combat Mode)	1064	N/A	4.5	5.6	
(Training Mode)	1540	N/A	0	0	
MMS(OH-58D)	1064		4.1	5.3	
NITE EAGLE (UH-1N)	1064		4.1	5.2	3.7
PAVE SPECTRE	1064	N/A	3.7	5.4	
TADS/PNVS (APACHE AAH)	1064	YES	4.0	5.5	

* Assume that built-in safety filter only protects against the wavelength of the laser in which it is installed and that it does not always protect against other laser wavelengths.

TABLE A-4. EYE PROTECTION REQUIREMENTS FOR COTS
MILITARY LASERS*

Device/Mounting	Wavelength (Nanometers)	Built-in Safety Filter (OD)**	Required Eye Protection (Optical Density (OD))		
			Unaided	Aided	Other Aircraft
MAN PORTABLE					
GCP-1&1A/ACP-2	800-850		1.7	3.6	
HAVIS M16 Aiming Light	850		1.1	1.1	
LPL-30	800-850		1.7	1.7	
M-931	850		0.7	0.8	
NITE EYE	980		1.7	1.7	
TD-100	850		1.1	1.1	
	632.8		0.3	0.3	
TD-100A	850		1.1	1.1	
	670		0.6	0.6	
AIRCRAFT MOUNTED					
AIM-1/ (MLR/EXL/D/DLR)	800-850		1.7	1.7	

* THIS HAZARD DATA COULD CHANGE SINCE THE GOVERNMENT HAS NO CONTROL OVER MANUFACTURING OF THESE PRODUCTS. HAZARD CHARACTERISTICS IN THIS TABLE ARE VALID AS OF THE DATE OF THE GOVERNMENT EVALUATION. PERIODICALLY CHECK WITH THE MANUFACTURER TO ENSURE THAT THE CHARACTERISTICS HAVE NOT CHANGED SINCE THE DATE OF THE LAST GOVERNMENT EVALUATION.

** Assume that built-in safety filter only protects against the wavelength of the laser in which it is installed and that it does not always protect against other laser wavelengths.

2.4 Buffer Zones. Each buffer zone in Tables A-1 and A-2 gives the minimum angular size of backstop behind the target which is used to terminate the beam. By ensuring that adequate backstop is present, laser energy is prevented from leaving the controlled area. Thus, if a moving target approaches the skyline within the buffer zone, laser operation should cease unless adequate airspace is controlled.

2.5 Eye Protection. Tables A-3 and A-4 summarize the eye protection optical density requirements for worse-case exposure at the laser output (unaided) or when collected with an optical instrument (total). The stated optical densities must be at the laser wavelength, otherwise the stated optical densities may offer very little protection. At longer distances away from the laser, the beam begins to spread out and become less harmful, so less optical density would be required at further distances away from the laser.

2.6 Fielded Laser System Descriptions

AC-130U Laser Illuminator Assembly (LIA) is a near IR illuminator mounted on the AC-130U aircraft (see Air Force Specialists of Paragraph 1.2).

AC-130U Laser Target Designator/Rangefinder LTD/RF is mounted on the AC-130U aircraft.

AH-1W Night Targeting System (NTS): This modification is to the Marine Corps AH-1 Telescopic Sight Unit including night targeting capability through the direct view optics using a Forward Looking Infrared (FLIR) and Laser Target Designator/Rangefinder system with camera and video tracker.

AIM-1: A Class 3b infrared diode aiming laser (830 - 850 nm wavelength) for use with night vision goggles. The AIM/MLR is mounted on Marine Corps XM-218, 50 caliber, M-60 and GAU-17B machine gun mounts. The AIM/EXL version is hard mounted on the AH-1 turret. AIM-1/D, AIM-1/DLR, AIM-1/MLR, AIM-1/EXL devices are integrated into the army AH-1F helicopter or used separately or mounted on army rifles. The ANVIS night vision goggles provide adequate protection against these lasers. CAT'S EYES do not protect against laser radiation.

Air to Ground Engagement System/Air Defense (AGES/AD) is an extension of MILES to air defense simulation.

AN/AAQ-14: LANTIRN System, Low Altitude Navigation and Targeting Infrared System for Night. A two pod system containing a terrain following radar (TFR), forward looking infrared (FLIR), laser designation, and later, a target recognition system. This system is designed to be flown on the F-15E and F-16 and the targeting pod is being integrated into the F-14.

AN/AAQ-22 Navigational Thermal Imaging System (NTIS): Turret mounted FLIR/Laser Rangefinder on the UH-1N helicopter.

AN/AAS-33A, Target Recognition Attack Multisensor (TRAM) laser system. This system is mounted on the A6-E aircraft and has a laser target designator and forward looking infrared (FLIR).

AN/AAS-37, Laser Rangefinder Designator mounted on the Marine Corps OV-10 observation aircraft.

AN/AAS-38A NITE HAWK. Pod mounted on lower left side of F/A-18 aircraft contains a Forward Looking Infrared (FLIR) and laser target designator/rangefinder (LTDR)

AN/GAQ-T1 LDSS: Laser Designator Simulator System.

AN/GVS-5 Laser Rangefinder Infrared Observation Set (handheld).

AN/PAQ-1 (LTD) Laser Target Designator. This is a lightweight, handheld, battery operated laser device. Forward observers use the LTD to designate targets.

AN/PAQ-3 Modular Universal Laser Equipment (MULE). This is a Marine Corps laser designator used with laser energy homing munitions. The MULE is man portable and is used only in a dismounted mode.

AN/PAQ-4, AN/PAQ-4A, pulsed AN/PAQ-4B and AN/PAQ-4C Infrared Aiming Light. These are class 1 military exempt laser systems using an 830 nm wavelength laser diode.

AN/PEQ-1 SOFLAM: Special Operating Forces Laser Marker.

AN/PVS-6 MELIOS. MELIOS was developed for infantry forward observers to measure distance. MELIOS is a class 3a restricted eye safe laser.

AN/TVQ-2 Ground/Vehicle Laser Locator Designator (G/VLLD). The G/VLLD is a principal ranging and laser designating device used by Army artillery forward observers with laser energy homing munitions. The G/VLLD is capable of designating stationary or moving vehicular targets and may be used in a stationary, vehicle mounted, or tripod supported dismounted mode. The primary vehicle mount is the Fire Support Team Vehicle (FISTV).

AN/VVG-1 Laser Rangefinder mounted on the M551A1 Sheridan vehicles.

AN/VVG-2 Laser Rangefinder mounted on the M60A3 tank. Used with two filters, the green Eye Safe Simulated Laser Rangefinder (ESSLR) filter and the red ESSLR filter. The green ESSLR is eye safe, the red ESSLR is less hazardous than the system without filters (see Appendix C).

AN/VVG-3 M1 tank laser rangefinder used with one eye-safe filter.

AN/VVS-1 Laser Rangefinder mounted on the M60A2 tank.

AVENGER: Avenger air defense system, turret mounted laser rangefinder on a HMMWV.

COMPACT LASER DESIGNATOR (CLD): A small, lightweight laser designator and/or rangefinder used by the Navy for target designation.

GCP-1 and ACP-2: Ground and Air Commanders Pointers. Small, lightweight Infrared aiming laser for use with night vision devices in target identification and night illumination. The GCP-1 operates at a power of 30 mw with zoomable beam from 30 ° to 0.03 ° (approximately 500 to 0.5 milliradians). Built-in sensor prevents operation in daylight; however, it does not sufficiently reduce power in dark conditions to prevent hazardous illumination of unprotected personnel within the NOHD. The GCP-1A and ACP-2 operate at 50 mw and do not incorporate the sensor. The finger mounted ACP-2 is not authorized for use by the Navy and Marine Corps.

Laser Augmented Airborne TOW (LAAT) mounted in the AH-1F COBRA Helicopter. The LAAT system consists of a laser rangefinder and receiver that is incorporated into the M65 tube launched, optically tracked, wire guided (TOW) telescopic sight unit.

LAV-105: Light Armored Vehicle-105 mm gun laser rangefinder.

LAV-AD: Light Armored Vehicle - Air Defense turret mounted CO₂ laser rangefinder.

LPL-30: A class 3b infrared diode aiming laser used by command to mark targets of choice to attacking forces equipped with the night vision goggles (NVG). The ANVIS NVGs provide adequate protection against class 3b lasers.

M55, Laser Tank Gunnery Trainer.

Mast Mounted Sight on the OH-58D that, in addition to thermal and optical sensors and imaging instrumentation, incorporates a laser rangefinder and/or designator.

MINI LASER RANGEFINDER (MLRF): A lightweight, handheld Neodymium YAG laser rangefinder. The RCA MLRF listed in Table A-1 is given the designation of AN/PVS-X to distinguish it from future MLRFs, which should not have off-axis radiation that would cause it to have such large buffer zone requirements as the AN/PVS-X.

MILES: Multiple Integrated Laser Engagement System . The MILES system uses low risk lasers and does not require service members to wear protective eyewear during the conduct of training with the MILES system.

NMMS: Navy Mast Mounted Sight. The Navy Mast Mounted Sight is mounted above deck for television and IR imaging and incorporates an eye-safe Class 1 LRF used to give range data for high priority targets such as mines, ships, and small water craft.

NITE EAGLE: FLIR/Laser Designator/Rangefinder turret adapted from the Aquilla system for the U.S. Marine Corps UH-1N helicopters. In training and field testing, prohibit laser firing when the laser in flight is less than 1000 meters from the target. This requirement is needed to prevent loss of track and possibility of the beam wandering off the target during slew and reorientation of the laser as the system passes over the target.

NITE EYE: Illuminator for IR camera. Produced by Air Force Phillips Laboratory. Approved only for use with output power below 30 mw.

PAVE PENNY (AN/AAS-35): Laser tracker pod used on the A-10 and A-7 aircraft. Does not contain a laser.

PAVE SPECTRE (AN/AVQ-19): Laser tracking and designator used on C-130 gunships.

PAVE SPIKE (AN/AVQ-12): Laser tracking and designator pod fitted on F-4 and F-111 aircraft.

PAVE TACK (AN/AVQ-26): Advanced optronics pod containing stabilized turret with FLIR, laser designator and tracker used on the F-4, RF-4, and F-111F aircraft.

SCOFT: SHILLELAGH Conduct of Fire Trainer.

TADS/PNVS: Target Acquisition and Designation System with Pilot Night Vision Sight mounted in the Apache Advanced Attack Helicopter.

TD-100: A day/night aiming laser. For daytime use this device uses a class 2 helium neon visible laser and for nighttime the TD-100 uses a class 3b infrared laser diode. Night vision goggles will provide adequate nighttime protection for personnel viewing the infrared laser.

2.7 Inactive Lasers Descriptions and Associated Systems. The following systems are not in the active inventory but are included for information

PAVE ARROW (AN/AVQ-14): This was a laser tracker pod developed for use in conjunction with the PAVE SPOT laser designator used on O-2A FAC spotter planes, C-123, and was planned for use on the F-100. It was eventually merged with the PAVE SWORD program.

PAVE BLIND BAT: The PAVE BLIND BAT consisted of a laser target designator to illuminate targets for the PAVE WAY guided bombs. The PAVE BLIND BAT had an effective range of 18,000 feet and was developed for use by AC-130 gunships to aid supporting fighter aircraft.

PAVE FIRE: Development of laser scanner to aid F-4 Phantoms in securing proper target bearing.

PAVE GAT: Development of a laser rangefinder for use on the B-52G.

PAVE KNIFE (AN/ALQ-10): The original laser designator pod developed by Aeronutronic-Ford and used in combat in Vietnam.

PAVE LANCE: Developmental effort to replace the PAVE KNIFE by improving night capability with the addition of a FLIR in place of the low light television (LLTV). Superseded by PAVE TACK.

PAVE LIGHT (AN/AVQ-9): Stabilized laser designator developed for the F-4 Phantom.

PAVE MACK: Development of laser seeker head for air to ground rockets. Project was also called LARS (Laser Aided Rocket System) and rockets were to be used in conjunction with Forward Air Controller (FAC) mounted PAVE SPOT designator.

PAVE NAIL (AN/AVQ-13): Modification of 18 OV-10 FAC aircraft with stabilized periscopic night sight and laser designator. Program coordinated with PAVE PHANTOM and PAVE SPOT.

PAVE PHANTOM: Addition of an ARN-92 Loran and computer to the F-4D allowing aircraft to store targeting information for eight separate positions illuminated by OV-10 PAVE NAIL.

PAVE POINTED: Palletized gun direction system consisting of a laser designator and/or rangefinder and LLTV employed on a C-123 and forerunner of subsequent gunship fire control stems.

PAVE PRISM: Aerodyne Research effort to develop IR and active laser seekers for use on the ASRAAM air-to-air missile.

PAVE PRONTO: Modification of AC-130 gunships for night attack including an LLTV Electro systems night observation camera, AAD-4, or AAD-6 FLIR and AVQ-17 illuminator.

PAVE SCOPE: Target acquisition aids for jet fighter aircraft such as the Eagle Eye (LAD) AN/AVG-8, and TISEO.

PAVE SHIELD: Classified project undertaken by Aeronautical Research Associates.

PAVE SPOT (AN/AVQ-12): Stabilized periscopic night vision sight developed by Varo for use on the O-2A FAC. The system was fitted with a Korad laser designator (ND:YAG).

PAVE STRIKE: A related group of air-to-ground strike programs include PAVE TACK and IR guided bombs.

PAVE SWORD (AN/AVQ-11): Laser tracker designed to pick up energy from targets illuminated by O-2A spotter planes. Used on F-4, and bore sighted with its radar set.

PAVE WAY: Code name for a wide variety of guided bomb projects, also refers to AN/AVQ-9 laser designator, developed by Martin Marietta for use on the F-4 Phantom.



APPENDIX B

**MULTIPLE INTEGRATED LASER ENGAGEMENT SYSTEM
(MILES) OPTICAL SAFETY SUMMARY**

APPENDIX B

MULTIPLE INTEGRATED LASER ENGAGEMENT SYSTEM (MILES) OPTICAL SAFETY SUMMARY

1.0 Scope

This hazard information applies to MILES exercises.

2.0 Applicable Documents

Information in this appendix was obtained from documents referenced in Chapter 2 and from informal documents provided by each of the service's safety specialists in Chapter 1.

3.0 MILES

The MILES is an ingenious system for scoring tactical exercises. Scoring is accomplished through an infrared beam emitted from each weapon and detected by a target which could be a man or vehicle. These systems do not present a hazard during normal field exercises; however, the beam is quite concentrated upon leaving the transmitter and cautionary measures are advised at extremely close engagement ranges. Table B-1 provides cautionary distances within which the weapons may be pointed at the face of another person. Because optical aids such as binoculars tend to concentrate this energy, these distances may be extended when unfiltered optical aids are used. In most cases, greater hazards than from the infrared energy exist during training exercises. In the case of the M-16 rifle, a person would be more likely to receive an eye injury from the impact of the blank fired at close range than from the infrared energy.

4.0 Schwartz Electro-Optic Controller Gun

The controller gun is used with the Tank Weapon Gunnery Simulation System/Precision Gunnery System (TWGSS/PGS) transmitter. The controller gun can simulate the kill codes of various MILES weapon simulators and reactivate troops or weapons systems during training exercises. This is a class 1 device and does not present a laser hazard.

TABLE B-1. NOHD FOR MILES AND OTHER TRAINING LASERS

DEVICE	NOHD(m)	NOHD-O(m) ¹
MILES I/II Large Gun Simulators	10	0
MILES I/II Small Arms Transmitters ²	0	0
M55(pulsed mode)	0	0
M55(continuous mode) ³	0	0
SCOFT	13	160
Schwartz Electro-optic Controller Gun	0	0

¹ Nominal Ocular Hazard Distance with optics.

² The pre-1986 rifle and machine gun simulators and MILES II machine gun simulators are not hazardous during blank fire, but have an NOHD of 7 meters during dry fire.

³ The M55 Tank Gunnery Trainer is not a hazard for momentary (0.25 seconds) viewing at any range.

APPENDIX C

**AIR TO GROUND ENGAGEMENT SYSTEM/AIR DEFENSE,
LASER AIR TO AIR GUNNERY SYSTEMS, PRECISION
GUNNERY TRAINING SYSTEM, AND AN/GTV-1
SAFETY SUMMARY**

APPENDIX C

AIR TO GROUND ENGAGEMENT SYSTEM/AIR DEFENSE, LASER AIR TO AIR GUNNERY SYSTEMS, PRECISION GUNNERY TRAINING SYSTEM, AND AN/GTV-1 SAFETY SUMMARY

1.0 Scope

This appendix provides hazard information on gunnery training systems.

2.0 Applicable Documents

Information in this appendix was obtained from documents referenced in Chapter 2 and from informal documents provided by each of the service's safety specialists in Chapter 1.

3.0 Safety Summary

The Air to Ground Engagement System/Air Defense (AGES/AD), Laser Air to Air Gunnery Systems (LATAGS), and Precision Gunnery Training System (PGTS) for TOW and Dragon missiles are an extension of and are similar to the Multiple Integrated Laser Engagement System (MILES). The AGES/AD, LATAGS and PGTS systems emit infrared laser beams to simulate various air defense, airborne, and ground weapons systems to improve realism during training. The AN/GVT-1 is a simulator of a target illuminated by a laser; it consists of an infrared laser emitter covered by a diffuser. Table C-1 lists cautionary viewing distance for an eye exposed from within the infrared laser beam for various versions of the AGES/AD, LATAGS and PGTS, and AN/GVT-1 simulators. Since these systems are pointed toward the sky, aimed at a retroreflector mounted on a target in a restricted area, or contained within a diffuser, no optical radiation hazard exists during normal field exercises. Other potential hazards such as posed by the blast simulators must be considered.

Tank Weapon Gunnery Simulator System/Precision Gunnery System (TWGSS/PGS) with modified telescope has a MILES type transmitter (SAAB version). The Target Acquisition and Designation System (TADS), Mast Mounted Sight (MMS) simulators, and the Hellfire Ground Support Simulator (HGSS) (all of which use a 1.54 nm Erbium laser and 904 nm laser diode) comprise the AGES II simulator system. The AGES II is used on the KIOWA 50-caliber gun and rocket simulators and on the wirestrike modification to the APACHE which includes a 20mm area weapon system (AWS) simulator.

JAVELIN Field Tactical Trainer (FTT) is a man portable training system for the shoulder fired JAVELIN antitank tactical weapon system. The FTT is similar in appearance to the actual JAVELIN without the explosive parts. The FTT is a key controlled trainer used during force-on-force training, gunner range qualification, and verification of operating skills in developing JAVELIN gunners. The FTT consists of the Simulated Round (SR) and an instructor station which monitors and records the functions of the SR. The SR includes a laser for simulation of target hits with a MILES compatible laser/detector system for scoring hits.

The Indoor Simulated Marksmanship Trainer (ISMT) and Infantry Squad Trainer (IST) use class 1 lasers (780 nm) in modified weapons to trace the aim point and calculate the location of simulated shots hitting a display screen. These lasers are commercially sold and registered with the FDA.

TABLE C-1. CAUTIONARY DISTANCES FOR EYE EXPOSURE TO THE AGES/AD, LATAGS, PGTS, TWGSS/PGS, JAVELIN, ISMT/IST, AND AN/GVT-1.

Device/Simulator	Unaided Viewing	Optically Aided (7 X 50 Binoculars)	Viewing OD
TOW	10 m	0 m	
AGES/AD-Chapparral	0 m	0 m	
Vulcan	10 m	0 m	
2.75" Rocket	10 m	0 m	
20 mm Gun	10 m	0 m	
Stinger	10 m	0 m	
AN/ASQ-193 LATAGS	0 m	438 m	
PGTS	0 m	154 m	
AGES II TADS, Mast Mounted			
Sight and HGSS			
Erbium Laser	0 m	0 m	
GaAs Laser	0 m	260 m	OD1
AGES II OH58D Kiowa Warrior			
50 - Caliber	8 m	22 m	OD1
Rocket	6 m	10 m	OD1
AGES II APACHE 20-mm AWS	10 m	50 m	OD1
TWGSS/PGS	0 m	5 m	
Controller Gun(Schwartz E-O)	0 m	0 m	
Javelin FTT	15 m	30 m	
AN/GVT-1 Simulated Laser			
Target			
With Diffuser	0 m	0 m	
Without Diffuser	2760 m	15,000 m	
ISMT/IST	0 m	0 m	

APPENDIX D

**SAMPLE CONTENT FOR LASER SAFETY SOP FOR
TRAINING WITH PORTABLE FIRE CONTROL LASERS**

APPENDIX D

SAMPLE CONTENT FOR LASER SAFETY SOP FOR TRAINING WITH PORTABLE FIRE CONTROL LASERS

1.0 Scope

This appendix provides suggested input for a laser safety Standard Operating Procedure (SOP).

2.0 WARNING

Laser range finders and designators can cause irreparable blindness if used improperly. Exposure of the eye to either the direct beam or a beam reflected from a flat mirror-like surface can cause an eye injury at a great distance. These lasers will not pose a skin or diffuse reflection viewing hazard. The following control measures will prevent such an exposure when training operators with portable fire control lasers in one-sided exercises.

- Laser operators shall periodically read and always follow this safety SOP.
- The laser should never be pointed at any unprotected personnel or flat mirror-like surfaces such as glass.
- The laser should be operated only on laser-approved ranges established in accordance with this handbook.
- Do not operate or experiment with the laser outside the range area unless it is specifically authorized. The laser exit port will be covered by an opaque dust cover and the laser disabled by removal of the battery when the laser is located outside the range area.
- The operator must positively identify the target and buffer areas before laser operations.
- Since the target area must be clear of specular reflectors, laser eye protection is not required for laser operators even when viewing the target area with binoculars. However, personnel should never enter the laser hazard area during lasing operations without appropriate laser eye protection. Such eye protection shall have curved lenses.
- No special precautions are necessary for firing during rain, fog, or snowfall. Certain ranges may be closed for operation if water begins ponding either on the ground or on snow.
- The operator should immediately report to the supervisor any suspected injury or defective equipment (such as misalignment of the laser beam with the pointing telescope) so that appropriate action may be taken.
- The SOP must also include general information such as responsibilities, emergency procedures, and the meaning of operational and warning signals.

APPENDIX E

EQUATIONS FOR LASER HAZARD EVALUATION

APPENDIX E

EQUATIONS FOR LASER HAZARD EVALUATION

1.0 Scope

This appendix contains equations for laser hazard evaluation to conform to range safety constraints.

2.0 Applicable Documents

The references from which these equations were derived are given in Chapter 2.

3.0 Equation Applications

The information provided in this appendix may be used in addition to the service-specific laser evaluation techniques. The equations are the means to determine minimum laser altitude above mean sea level (msl) which will satisfy the safety constraints for use of an airborne laser system on a particular range and at a specified distance from the target. Equations are provided to determine positions of ground based lasers that will satisfy the safety constraints on a given range.

3.1 Sloping Ranges. Many ranges have a sloping terrain which yields a laser footprint plus buffer zone resembling an ellipse. This footprint will be a more elongated ellipse for airborne lasers illuminating a downward sloping terrain and a truncated ellipse for lasers illuminating an upward sloping terrain.

3.2 Shipboard Laser System. The use of these equations in the case of shipboard laser systems would provide pessimistic results. The lack of terrain features to act as a backstop in an open ocean environment, when combined with the longer NOHD of a more powerful shipboard laser system, causes the curvature of the earth to play a significant role in shipboard laser evaluations. The optical horizon from an elevation of 80-feet msl is approximately 9.5 nmi. Because at a range of 19 nmi (the approximate NOHD for unaided viewing of some proposed shipboard laser systems) the propagated beam could not possibly be below 80-feet msl, the use of optical aids aboard other surface vessels would not increase the probability of exposure. It would increase the extent of damage should an exposure occur. It would also require coordination with those responsible for the air space and coordination of satellite space with Space Command, Cheyenne Mountain, Colorado.

3.3 Hazard Evaluation. The goal of airborne laser and ground laser safety evaluations on many ranges is to determine the aircraft flight profile required to keep the laser beam plus its buffer within the confines of the target restricted area, that is, the LSDZ.

3.3.1 Buffered Footprint Definition. The buffered footprint is the projection of the laser beam and its associated buffer zone on the ground surrounding the intended target. The footprint configuration and size are determined by the range from the laser aperture to the target, the incidence angle of the laser beam LOS on the target or range area plane and the assigned buffer angle. Figures E-1 and E-2 show the geometry of the buffered footprint. The footprint of this laser is an ellipse whose width is typically quite small and a simple function of the distance to the target. The spreading of the beam along the ground in the direction of the laser LOS is of primary concern and changes drastically as a function of the aircraft's height above and distance to the target.

3.3.2 Hazard Evaluation Without Specular Reflections. This evaluation should be done for each aircraft heading and should account for slope of the terrain.

3.3.2.1 Single Laser Aircraft Heading. Provided that the laser target and surrounding area are clear of specular reflectors, the mathematical model used to evaluate range safety must assure that the laser beam and its associated buffered footprint fall within the prescribed boundaries of the controlled and restricted ground space. The following paragraphs describe the equations used for this model. Figure E-1 shows an aircraft laser illuminating a small target area with the associated buffer zones fore and aft. Figure E-2 shows an airborne laser illuminating a large target area with near and far buffer zones assigned as if the laser were always aimed at the nearest and farthest targets. The plan views of these buffered footprints are shown on Figures E-3 and E-4. When using Tables E-1 through E-5 to determine buffered footprint widths and lengths, refer to the rectangle in Figure E-4 to visualize dimensions in the footprint tables which are listed as forward, aft, and width.

3.3.2.2 Multiple Laser Aircraft Headings. If the laser attack will be from several bearings (for example 45° to 135°), the LSDZ will be a summation of all possible buffered footprints as shown on Figure E-5. If the attack bearings are not specified or attack from any direction is desired, the LSDZ will be a circle with a radius equal to the longest forward or aft buffered footprint dimension for the possible altitudes or slant ranges (see Figure E-6).

3.3.2.3 Level Ground Examples. The following examples are provided as an application of the conditions described previously.

3.3.2.3.1 Example 1 (Level Ground). Referring to Table E-1 for a PAVE SPIKE laser fired from 200 to 1000 feet above ground level (AGL) at ranges from 1 to 4 miles, the longest buffered footprint dimensions on level ground are 8500 feet forward, 5960 feet aft, and 130 feet wide. The areas within these target distances must be restricted as the LSDZ.

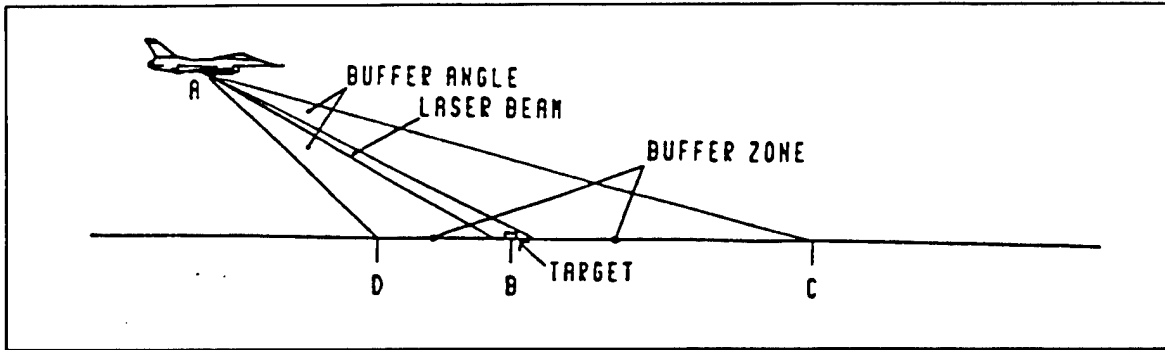

Figure E-1. Laser footprint with single target side view.

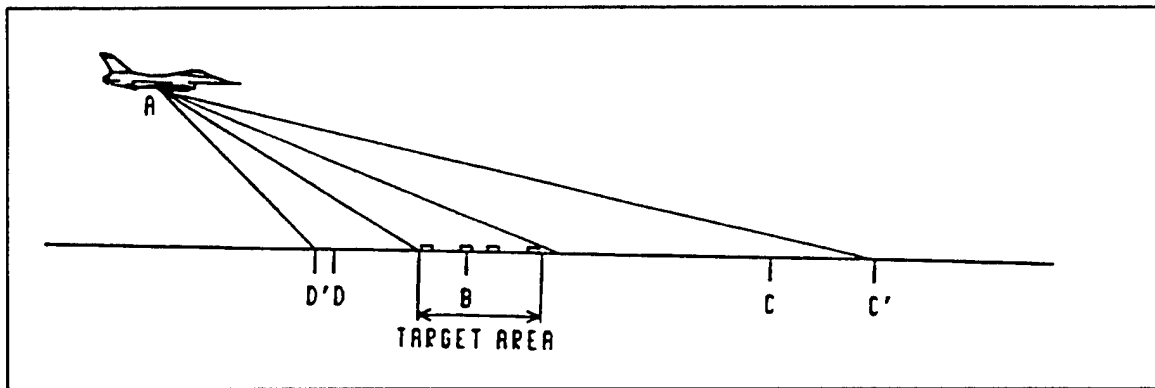

Figure E-2. Laser footprint with multiple targets - side view.

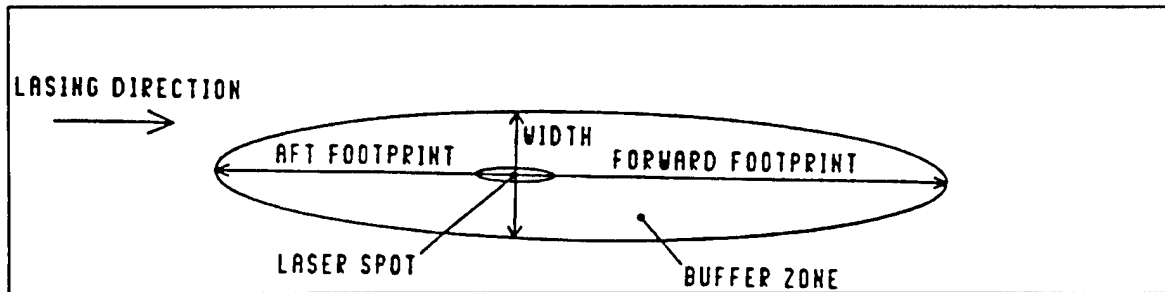

Figure E-3. Laser footprint - top view.

Table E-1. Laser Footprint Table For: Pave Spike (Using Vacuum NOHD)
 Table based on: Flat terrain, Buffer = 2.5 mrad, Divergence = .35 mrad
 NOHD= 10000 meters (32900 feet or 5.4 nautical miles)
 Table values are FOOTPRINT dimensions(feet and meters)

FOOTPRINT FORWARD - distance beyond target
 FOOTPRINT AFT - distance from target toward aircraft.
 FOOTPRINT WIDTH - total width at target.
 NOTE: -99 Indicates an impossible alt./range combination.

SLANT RANGE (nautical miles, feet, and meters)

ALTITUDE (feet)	FOOTPRINT	1.0 NM	2.0 NM	3.0 NM	4.0 NM	5.0 NM	6.0 NM	7.0 NM	8.0 NM	9.0 NM
		6080 ft 1850 m	12200 ft 3700 m	18200 ft 5560 m	24300 ft 7410 m	30400 ft 9260 m	36500 ft 11100 m	42500 ft 13000 m	48600 ft 14800 m	54700 ft 16700 m
100	FORWARD	1180 ft	5850 ft	14600 ft	8500 ft	2420 ft	0 ft	0 ft	0 ft	0 ft
		359 m	1780 m	4440 m	2590 m	737 m	0 m	0 m	0 m	0 m
	AFT	850 ft	2980 ft	5970 ft	9580 ft	13600 ft	18000 ft	22500 ft	27500 ft	32500 ft
		259 m	909 m	1820 m	2920 m	4150 m	5490 m	6900 m	8380 m	9900 m
200	FORWARD	537 ft	2360 ft	5880 ft	8500 ft	2420 ft	0 ft	0 ft	0 ft	0 ft
		164 m	719 m	1790 m	2590 m	731 m	0 m	0 m	0 m	0 m
	AFT	457 ft	1,700 ft	3570 ft	5960 ft	8780 ft	11900 ft	15400 ft	19200 ft	23100 ft
		139 m	518 m	1090 m	1820 m	2680 m	3640 m	4700 m	5840 m	7040 m
300	FORWARD	348 ft	1480 ft	3540 ft	6720 ft	2420 ft	0 ft	0 ft	0 ft	0 ft
		106 m	450 m	1080 m	2050 m	737 m	0 m	0 m	0 m	0 m
	AFT	312 ft	1190 ft	2550 ft	4330 ft	6480 ft	8940 ft	11700 ft	14700 ft	17700 ft
		95 m	362 m	777 m	1320 m	1970 m	2730 m	3560 m	4490 m	5420 m
400	FORWARD	257 ft	1070 ft	2530 ft	4720 ft	2420 ft	0 ft	0 ft	0 ft	0 ft
		78 m	328 m	771 m	1440 m	737 m	0 m	0 m	0 m	0 m
	AFT	237 ft	913 ft	1980 ft	3400 ft	5130 ft	7150 ft	9150 ft	11150 ft	13150 ft
		72 m	278 m	604 m	1040 m	1560 m	2180 m	2800 m	3420 m	4040 m
500	FORWARD	204 ft	845 ft	1970 ft	3630 ft	2420 ft	0 ft	0 ft	0 ft	0 ft
		62 m	258 m	600 m	1110 m	738 m	0 m	0 m	0 m	0 m
	AFT	191 ft	742 ft	1620 ft	2800 ft	4250 ft	5950 ft	7400 ft	8850 ft	10300 ft
		58 m	226 m	494 m	852 m	1290 m	1810 m	2330 m	2850 m	3370 m
600	FORWARD	169 ft	696 ft	1610 ft	2950 ft	2420 ft	0 ft	0 ft	0 ft	0 ft
		52 m	212 m	491 m	900 m	738 m	0 m	0 m	0 m	0 m
	AFT	160 ft	625 ft	1370 ft	2380 ft	3620 ft	5100 ft	6500 ft	7900 ft	9300 ft
		49 m	190 m	418 m	724 m	1100 m	1550 m	2000 m	2450 m	2900 m
700	FORWARD	144 ft	592 ft	1360 ft	2490 ft	2420 ft	0 ft	0 ft	0 ft	0 ft
		44 m	180 m	416 m	758 m	738 m	0 m	0 m	0 m	0 m
	AFT	138 ft	539 ft	1190 ft	2070 ft	3160 ft	4450 ft	5740 ft	7030 ft	8320 ft
		42 m	164 m	362 m	630 m	963 m	1360 m	1750 m	2140 m	2530 m
800	FORWARD	126 ft	515 ft	1180 ft	2150 ft	2420 ft	0 ft	0 ft	0 ft	0 ft
		38 m	157 m	361 m	655 m	738 m	0 m	0 m	0 m	0 m
	AFT	121 ft	475 ft	1050 ft	1830 ft	2800 ft	3960 ft	5120 ft	6280 ft	7440 ft
		37 m	145 m	319 m	557 m	854 m	1210 m	1570 m	2030 m	2490 m
	WIDTH	33 ft	65 ft	98 ft	130 ft	163 ft	195 ft	228 ft	260 ft	293 ft
		10 m	20 m	30 m	40 m	50 m	59 m	69 m	79 m	89 m

Table E-2. Laser Footprint Table For: Pavé Spike (Including Atmospheric Attenuation for Lasing from Altitudes below 1 km MSL Only)
 Table based on: Flat terrain, Buffer = 2.5 mrad, Divergence = .35 mrad
 NOHD= 8200 meters (26896 feet or 4.4 nautical miles)
 Table values are FOOTPRINT dimensions (feet and meters)

ALTITUDE (feet)	FOOTPRINT	SLANT RANGE (nautical miles, feet, and meters)									
		1.0 NM	2.0 NM	3.0 NM	4.0 NM	5.0 NM	6.0 NM	7.0 NM	8.0 NM	9.0 NM	
100	FORWARD	6080 ft 1850 m	12200 ft 3700 m	18200 ft 5560 m	24300 ft 7410 m	30400 ft 9260 m	36500 ft 11100 m	42500 ft 13000 m	48600 ft 14800 m	54700 ft 16700 m	
	AFT	1180 ft 359 m	5850 ft 1780 m	8670 ft 2640 m	2590 ft 790 m	0 ft 0 m	0 ft 0 m	0 ft 0 m	0 ft 0 m	0 ft 0 m	
200	FORWARD	850 ft 259 m	2980 ft 909 m	5970 ft 1820 m	9580 ft 2920 m	13600 ft 4150 m	18000 ft 5490 m	22600 ft 6900 m	27500 ft 8380 m	32500 ft 9900 m	
	AFT	537 ft 164 m	2360 ft 719 m	5880 ft 1790 m	2590 ft 790 m	0 ft 0 m	0 ft 0 m	0 ft 0 m	0 ft 0 m	0 ft 0 m	
300	FORWARD	312 ft 95 m	1190 ft 362 m	2550 ft 777 m	4330 ft 1320 m	6480 ft 1970 m	8780 ft 2680 m	11900 ft 3640 m	15900 ft 4860 m	19900 ft 6070 m	
	AFT	257 ft 78 m	1070 ft 328 m	2530 ft 771 m	2590 ft 790 m	0 ft 0 m	0 ft 0 m	0 ft 0 m	0 ft 0 m	0 ft 0 m	
400	FORWARD	237 ft 72 m	913 ft 278 m	1980 ft 604 m	3400 ft 1040 m	5130 ft 1560 m	6880 ft 2100 m	8630 ft 2630 m	10380 ft 3170 m	12130 ft 3700 m	
	AFT	204 ft 62 m	845 ft 258 m	1970 ft 600 m	2590 ft 790 m	0 ft 0 m	0 ft 0 m	0 ft 0 m	0 ft 0 m	0 ft 0 m	
500	FORWARD	191 ft 58 m	742 ft 226 m	1620 ft 494 m	2800 ft 852 m	4250 ft 1290 m	5700 ft 1740 m	7150 ft 2190 m	8600 ft 2650 m	10050 ft 3110 m	
	AFT	169 ft 52 m	696 ft 212 m	1610 ft 491 m	2590 ft 790 m	0 ft 0 m	0 ft 0 m	0 ft 0 m	0 ft 0 m	0 ft 0 m	
600	FORWARD	144 ft 44 m	592 ft 180 m	1360 ft 416 m	2490 ft 758 m	3620 ft 1100 m	4750 ft 1450 m	5900 ft 1800 m	7050 ft 2150 m	8200 ft 2500 m	
	AFT	138 ft 42 m	539 ft 164 m	1190 ft 362 m	2070 ft 630 m	0 ft 0 m	0 ft 0 m	0 ft 0 m	0 ft 0 m	0 ft 0 m	
700	FORWARD	126 ft 38 m	515 ft 157 m	1180 ft 361 m	2150 ft 655 m	3280 ft 1000 m	4370 ft 1330 m	5460 ft 1670 m	6550 ft 2000 m	7640 ft 2330 m	
	AFT	121 ft 37 m	475 ft 145 m	1050 ft 319 m	1830 ft 557 m	0 ft 0 m	0 ft 0 m	0 ft 0 m	0 ft 0 m	0 ft 0 m	
800	FORWARD	100 ft 30 m	400 ft 120 m	900 ft 270 m	1600 ft 480 m	2400 ft 720 m	3200 ft 960 m	4000 ft 1200 m	4800 ft 1440 m	5600 ft 1680 m	
	AFT	98 ft 30 m	300 ft 90 m	600 ft 180 m	900 ft 270 m	0 ft 0 m	0 ft 0 m	0 ft 0 m	0 ft 0 m	0 ft 0 m	
900	FORWARD	80 ft 24 m	320 ft 96 m	720 ft 216 m	1200 ft 360 m	1600 ft 480 m	2000 ft 600 m	2400 ft 720 m	2800 ft 840 m	3200 ft 960 m	
	AFT	79 ft 24 m	240 ft 72 m	480 ft 144 m	720 ft 216 m	0 ft 0 m	0 ft 0 m	0 ft 0 m	0 ft 0 m	0 ft 0 m	
1000	FORWARD	60 ft 18 m	240 ft 72 m	480 ft 144 m	720 ft 216 m	960 ft 288 m	1200 ft 360 m	1440 ft 432 m	1680 ft 504 m	1920 ft 576 m	
	AFT	59 ft 18 m	180 ft 54 m	360 ft 108 m	540 ft 162 m	0 ft 0 m	0 ft 0 m	0 ft 0 m	0 ft 0 m	0 ft 0 m	
1100	FORWARD	40 ft 12 m	160 ft 48 m	320 ft 96 m	480 ft 144 m	640 ft 192 m	800 ft 240 m	960 ft 288 m	1120 ft 336 m	1280 ft 384 m	
	AFT	33 ft 10 m	120 ft 36 m	240 ft 72 m	360 ft 108 m	0 ft 0 m	0 ft 0 m	0 ft 0 m	0 ft 0 m	0 ft 0 m	
1200	FORWARD	30 ft 9 m	120 ft 36 m	240 ft 72 m	360 ft 108 m	480 ft 144 m	600 ft 180 m	720 ft 216 m	840 ft 252 m	960 ft 288 m	
	AFT	26 ft 8 m	96 ft 28 m	192 ft 57 m	288 ft 86 m	0 ft 0 m	0 ft 0 m	0 ft 0 m	0 ft 0 m	0 ft 0 m	
1300	FORWARD	20 ft 6 m	80 ft 24 m	160 ft 48 m	240 ft 72 m	320 ft 96 m	400 ft 120 m	480 ft 144 m	560 ft 168 m	640 ft 192 m	
	AFT	17 ft 5 m	64 ft 19 m	128 ft 38 m	192 ft 57 m	0 ft 0 m	0 ft 0 m	0 ft 0 m	0 ft 0 m	0 ft 0 m	
1400	FORWARD	15 ft 4.5 m	60 ft 18 m	120 ft 36 m	180 ft 54 m	240 ft 72 m	300 ft 90 m	360 ft 108 m	420 ft 126 m	480 ft 144 m	
	AFT	13 ft 4 m	48 ft 14 m	96 ft 28 m	144 ft 43 m	0 ft 0 m	0 ft 0 m	0 ft 0 m	0 ft 0 m	0 ft 0 m	
1500	FORWARD	10 ft 3 m	40 ft 12 m	80 ft 24 m	120 ft 36 m	160 ft 48 m	200 ft 60 m	240 ft 72 m	280 ft 84 m	320 ft 96 m	
	AFT	9 ft 2.7 m	36 ft 10.8 m	72 ft 21.6 m	108 ft 32.4 m	0 ft 0 m	0 ft 0 m	0 ft 0 m	0 ft 0 m	0 ft 0 m	
1600	FORWARD	7.5 ft 2.25 m	30 ft 9 m	60 ft 18 m	90 ft 27 m	120 ft 36 m	150 ft 45 m	180 ft 54 m	210 ft 63 m	240 ft 72 m	
	AFT	6.5 ft 1.95 m	24 ft 7.2 m	48 ft 14.4 m	72 ft 21.6 m	0 ft 0 m	0 ft 0 m	0 ft 0 m	0 ft 0 m	0 ft 0 m	
1700	FORWARD	5 ft 1.5 m	20 ft 6 m	40 ft 12 m	60 ft 18 m	80 ft 24 m	100 ft 30 m	120 ft 36 m	140 ft 42 m	160 ft 48 m	
	AFT	4.5 ft 1.35 m	16 ft 4.8 m	32 ft 9.6 m	48 ft 14.4 m	0 ft 0 m	0 ft 0 m	0 ft 0 m	0 ft 0 m	0 ft 0 m	
1800	FORWARD	3.75 ft 1.125 m	15 ft 4.5 m	30 ft 9 m	45 ft 13.5 m	60 ft 18 m	75 ft 22.5 m	90 ft 27 m	105 ft 31.5 m	120 ft 36 m	
	AFT	3.25 ft 0.975 m	12 ft 3.6 m	24 ft 7.2 m	36 ft 10.8 m	0 ft 0 m	0 ft 0 m	0 ft 0 m	0 ft 0 m	0 ft 0 m	
1900	FORWARD	2.75 ft 0.825 m	11 ft 3.3 m	22 ft 6.6 m	33 ft 9.9 m	44 ft 13.2 m	55 ft 16.5 m	66 ft 19.8 m	77 ft 23.1 m	88 ft 26.4 m	
	AFT	2.375 ft 0.7125 m	9 ft 2.7 m	18 ft 5.4 m	27 ft 8.1 m	0 ft 0 m	0 ft 0 m	0 ft 0 m	0 ft 0 m	0 ft 0 m	
2000	FORWARD	2 ft 0.6 m	8 ft 2.4 m	16 ft 4.8 m	24 ft 7.2 m	32 ft 9.6 m	40 ft 12 m	48 ft 14.4 m	56 ft 16.8 m	64 ft 19.2 m	
	AFT	1.75 ft 0.525 m	7 ft 2.1 m	14 ft 4.2 m	21 ft 6.3 m	0 ft 0 m	0 ft 0 m	0 ft 0 m	0 ft 0 m	0 ft 0 m	
2100	FORWARD	1.5 ft 0.45 m	6 ft 1.8 m	12 ft 3.6 m	18 ft 5.4 m	24 ft 7.2 m	30 ft 9 m	36 ft 10.8 m	42 ft 12.6 m	48 ft 14.4 m	
	AFT	1.375 ft 0.4125 m	5.4 ft 1.62 m	10.8 ft 3.24 m	16.2 ft 4.86 m	0 ft 0 m	0 ft 0 m	0 ft 0 m	0 ft 0 m	0 ft 0 m	
2200	FORWARD	1.125 ft 0.3375 m	4.5 ft 1.35 m	9 ft 2.7 m	13.5 ft 4.05 m	18 ft 5.4 m	22.5 ft 6.75 m	27 ft 8.1 m	31.5 ft 9.45 m	36 ft 10.8 m	
	AFT	0.975 ft 0.2925 m	3.6 ft 1.08 m	7.2 ft 2.16 m	10.8 ft 3.24 m	0 ft 0 m	0 ft 0 m	0 ft 0 m	0 ft 0 m	0 ft 0 m	
2300	FORWARD	0.875 ft 0.2625 m	3.5 ft 1.05 m	7 ft 2.1 m	10.5 ft 3.15 m	14 ft 4.2 m	17.5 ft 5.25 m	21 ft 6.3 m	24.5 ft 7.35 m	28 ft 8.4 m	
	AFT	0.75 ft 0.225 m	3 ft 0.9 m	6 ft 1.8 m	9 ft 2.7 m	0 ft 0 m	0 ft 0 m	0 ft 0 m	0 ft 0 m	0 ft 0 m	
2400	FORWARD	0.75 ft 0.225 m	3 ft 0.9 m	6 ft 1.8 m	9 ft 2.7 m	12 ft 3.6 m	15 ft 4.5 m	18 ft 5.4 m	21 ft 6.3 m	24 ft 7.2 m	
	AFT	0.625 ft 0.1875 m	2.5 ft 0.75 m	5 ft 1.5 m	7.5 ft 2.25 m	0 ft 0 m	0 ft 0 m	0 ft 0 m	0 ft 0 m	0 ft 0 m	
2500	FORWARD	0.625 ft 0.1875 m	2.5 ft 0.75 m	5 ft 1.5 m	7.5 ft 2.25 m	10 ft 3 m	12.5 ft 3.75 m	15 ft 4.5 m	17.5 ft 5.25 m	20 ft 6 m	
	AFT	0.5625 ft 0.16875 m	2.25 ft 0.675 m	4.5 ft 1.35 m	6.75 ft 2.025 m	0 ft 0 m	0 ft 0 m	0 ft 0 m	0 ft 0 m	0 ft 0 m	
2600	FORWARD	0.5625 ft 0.16875 m	2.25 ft 0.675 m	4.5 ft 1.35 m	6.75 ft 2.025 m	9 ft 2.7 m	11.25 ft 3.375 m	13.5 ft 4.05 m	15.75 ft 4.725 m	18 ft 5.4 m	
	AFT	0.4875 ft 0.14625 m	1.875 ft 0.5625 m	3.75 ft 1.125 m	5.625 ft 1.6875 m	0 ft 0 m	0 ft 0 m	0 ft 0 m	0 ft 0 m	0 ft 0 m	
2700	FORWARD	0.4875 ft 0.14625 m	1.875 ft 0.5625 m	3.75 ft 1.125 m	5.625 ft 1.6875 m	7.5 ft 2.25 m	9.375 ft 2.8125 m	11.25 ft 3.375 m	13.125 ft 3.9375 m	15 ft 4.5 m	
	AFT	0.4125 ft 0.12375 m	1.5 ft 0.45 m	3 ft 0.9 m	4.5 ft 1.35 m	0 ft 0 m	0 ft 0 m	0 ft 0 m	0 ft 0 m	0 ft 0 m	
2800	FORWARD	0.4125 ft 0.12375 m	1.5 ft 0.45 m	3 ft 0.9 m	4.5 ft 1.35 m	6 ft 1.8 m	7.5 ft 2.25 m	9 ft 2.7 m	10.5 ft 3.15 m	12 ft 3.6 m	
	AFT	0.3625 ft 0.10875 m	1.35 ft 0.405 m	2.7 ft 0.81 m	4.05 ft 1.215 m	0 ft 0 m	0 ft 0 m	0 ft 0 m	0 ft 0 m	0 ft 0 m	
2900	FORWARD	0.3625 ft 0.10875 m	1.35 ft 0.405 m	2.7 ft 0.81 m	4.05 ft 1.215 m	5.25 ft 1.575 m	6.5625 ft 1.96875 m	7.875 ft 2.3625 m	9.1875 ft 2.75625 m	10.5 ft 3.15 m	
	AFT	0.3125 ft 0.09375 m	1.125 ft 0.3375 m	2.25 ft 0.675 m	3.375 ft 1.0125 m	0 ft 0 m	0 ft 0 m	0 ft 0 m	0 ft 0 m	0 ft 0 m	
3000	FORWARD	0.3125 ft 0.09375 m	1.125 ft 0.3375 m	2.25 ft 0.675 m	3.375 ft 1.0125 m	4.5 ft 1.35 m	5.625 ft 1.6875 m	6.75 ft 2.025 m	7.875 ft 2.3625 m	9 ft 2.7 m	
	AFT	0.2625 ft 0.07875 m	0.975 ft 0.2925 m	1.95 ft 0.585 m	2.925 ft 0.8775 m	0 ft 0 m	0 ft 0 m	0 ft 0 m	0 ft 0 m	0 ft 0 m	
3100	FORWARD	0.2625 ft 0.07875 m	0.975 ft 0.2925 m	1.95 ft 0.585 m	2.925 ft 0.8775 m	4.05 ft 1.215 m	5.0625 ft 1.51875 m	6.125 ft 1.8375 m	7.1875 ft 2.15625 m	8.25 ft 2.475 m	
	AFT	0.2125 ft 0.06375 m	0.825 ft 0.2475 m	1.65 ft 0.495 m	2.475 ft 0.7425 m	0 ft 0 m	0 ft 0 m	0 ft 0 m	0 ft 0 m	0 ft 0 m	
3200	FORWARD	0.2125 ft 0.06375 m	0.825 ft 0.2475 m	1.65 ft 0.495 m	2.475 ft 0.7425 m	3.75 ft 1.125 m	4.6875 ft 1.40625 m	5.625 ft 1.6875 m	6.5625 ft 1.96875 m	7.5 ft 2.25 m	
	AFT	0.1625 ft 0.04875 m	0.675 ft 0.2025 m	1.35 ft 0.405 m	2.025 ft 0.6075 m	0 ft 0 m	0 ft 0 m	0 ft 0 m	0 ft 0 m	0 ft 0 m	
3300	FORWARD	0.1625 ft 0.04875 m	0.675 ft 0.2025 m	1.35 ft 0.405 m	2.025 ft 0.6075 m	3.375 ft 1.0125 m	4.21875 ft 1.265625 m	5.125 ft 1.5375 m	6.0625 ft 1.81875 m	7 ft 2.1 m	
	AFT	0.1375 ft 0.04125 m	0.5625 ft 0.16875 m	1.125 ft 0.3375 m	1.6875 ft 0.50625 m	0 ft 0 m	0 ft 0 m	0 ft 0 m	0 ft 0 m	0 ft 0 m	
3400	FORWARD	0.1375 ft 0.04125 m	0.5625 ft 0.16875 m	1.125 ft 0.3375 m	1.6875 ft 0.50625 m	3.0625 ft 0.91875 m	3.828125 ft 1.153125 m	4.625 ft 1.3875 m	5.4375 ft 1.63125 m	6.25 ft 1.875 m	
	AFT	0.1125 ft 0.03375 m	0.46875 ft 0.140625 m	0.9375 ft 0.28125 m	1.40625 ft 0.421875 m	0 ft 0 m	0 ft 0 m	0 ft 0 m	0 ft 0 m	0 ft 0 m	
3500	FORWARD	0.1125 ft 0.03375 m	0.46875 ft 0.140625 m	0.9375 ft 0.28125 m	1.40625 ft 0.421875 m	2.71875 ft 0.815625 m	3.396875 ft 1.0190625 m	4.0625 ft 1.228125 m	4.8125 ft 1.453125 m	5.5625 ft 1.66875 m	
	AFT	0.0875 ft 0.02625 m	0.38125 ft 0.114375 m	0.7625 ft 0.22875 m	1.14375 ft 0.343125 m	0 ft 0 m	0 ft 0 m	0 ft 0 m	0 ft 0 m	0 ft 0 m	
3600	FORWARD	0.0875 ft 0.02625 m	0.38125 ft 0.114375 m	0.7625 ft 0.22875 m	1.14375 ft 0.343125 m	2.41875 ft 0.725625 m	2.996875 ft 0.8990625 m	3.575 ft 1.073125 m	4.15625 ft 1.246875 m	4.75 ft 1.425 m	
	AFT	0.0625 ft 0.01875 m	0.3125 ft 0.09375 m	0.625 ft 0.1875 m	0.9375 ft 0.28125 m	0 ft 0 m	0 ft 0 m	0 ft 0 m	0 ft 0 m	0 ft 0 m	
3700	FORWARD	0.0625 ft 0.01875 m	0.3125 ft 0.09375 m	0.625 ft 0.1875 m	0.9375 ft 0.28125 m	2.					

Table E-3. Laser Footprint Table For: Pave Tack (Using Vacuum NOHD)
 Table based on: Flat terrain, Buffer = 2 mrad, Divergence = 0 mrad
 NOHD= 16000 meters (52480 feet or 8.6 nautical miles)
 Table values are FOOTPRINT dimensions(feet and meters)

FOOTPRINT FORWARD - distance beyond target.
 FOOTPRINT AFT - distance from target back aircraft.
 FOOTPRINT WIDTH - total width at target.
 NOTE: -99 indicates an impossible alt./range combination.

SLANT RANGE (nautical miles, feet, and meters)

ALTITUDE (feet)	FOOTPRINT	1.0 NM 6080 ft 1850 m	2.0 NM 12200 ft 3700 m	3.0 NM 18200 ft 5560 m	4.0 NM 24300 ft 7410 m	5.0 NM 30400 ft 9260 m	6.0 NM 36500 ft 11100 m	7.0 NM 42500 ft 13000 m	8.0 NM 48600 ft 14800 m	9.0 NM 54700 ft 16700 m
100	FORWARD	841 ft	3900 ft	10500 ft	23000 ft	22100 ft	16000 ft	9950 ft	3870 ft	0 ft
	AFT	256 m	1190 m	3190 m	7010 m	6740 m	4880 m	3030 m	1180 m	0 m
200	FORWARD	658 ft	2380 ft	4870 ft	7950 ft	11500 ft	15400 ft	19600 ft	24000 ft	28600 ft
	AFT	201 m	724 m	1480 m	2420 m	3500 m	4690 m	5960 m	7300 m	8710 m
300	FORWARD	393 ft	1680 ft	4060 ft	7800 ft	13300 ft	16000 ft	9950 ft	3870 ft	0 ft
	AFT	120 m	512 m	1240 m	2380 m	4040 m	4880 m	3030 m	1180 m	0 m
400	FORWARD	348 ft	1320 ft	2810 ft	4750 ft	7080 ft	9740 ft	12700 ft	15900 ft	19300 ft
	AFT	106 m	401 m	857 m	1450 m	2160 m	2970 m	3870 m	4850 m	5890 m
500	FORWARD	257 ft	1070 ft	2520 ft	4700 ft	7720 ft	11700 ft	9950 ft	3870 ft	0 ft
	AFT	78 m	327 m	769 m	1430 m	2350 m	3570 m	3030 m	1180 m	0 m
600	FORWARD	179 ft	911 ft	1980 ft	3390 ft	5120 ft	7130 ft	9400 ft	11900 ft	14600 ft
	AFT	55 m	278 m	602 m	1030 m	1560 m	2170 m	2860 m	3630 m	4450 m
700	FORWARD	126 ft	786 ft	1830 ft	3360 ft	5440 ft	8130 ft	9950 ft	3870 ft	0 ft
	AFT	33 m	240 m	557 m	1020 m	1660 m	2480 m	3030 m	1180 m	0 m
800	FORWARD	121 ft	621 ft	1430 ft	2620 ft	4200 ft	6220 ft	8720 ft	3870 ft	0 ft
	AFT	37 m	172 m	378 m	656 m	1000 m	1410 m	1880 m	2410 m	2990 m
900	FORWARD	107 ft	513 ft	1180 ft	2140 ft	3420 ft	5040 ft	7030 ft	3870 ft	0 ft
	AFT	33 m	156 m	359 m	653 m	1040 m	1540 m	2140 m	1180 m	0 m
1000	FORWARD	104 ft	473 ft	1040 ft	1820 ft	2790 ft	3950 ft	5280 ft	6780 ft	8430 ft
	AFT	32 m	144 m	318 m	555 m	852 m	1200 m	1610 m	2070 m	2570 m
1100	FORWARD	104 ft	437 ft	1000 ft	1810 ft	2890 ft	4240 ft	5880 ft	3870 ft	0 ft
	AFT	32 m	133 m	305 m	553 m	880 m	1290 m	1790 m	1180 m	0 m
1200	FORWARD	94 ft	381 ft	870 ft	1570 ft	2500 ft	3660 ft	5060 ft	3870 ft	0 ft
	AFT	29 m	116 m	265 m	479 m	761 m	1110 m	1540 m	1180 m	0 m
1300	FORWARD	91 ft	358 ft	795 ft	1390 ft	2140 ft	3050 ft	4090 ft	5270 ft	6580 ft
	AFT	28 m	109 m	242 m	424 m	654 m	928 m	1250 m	1610 m	2000 m
1400	FORWARD	24 ft	49 ft	73 ft	97 ft	122 ft	146 ft	170 ft	194 ft	219 ft
	AFT	7 m	15 m	22 m	30 m	37 m	44 m	52 m	59 m	67 m

Table E-4. Laser Footprint Table For: Pave Tack (Including Atmospheric Attenuation for Lasing from Altitudes below 1 km MSL Only)
 Table based on: Flat terrain, Buffer = 2 mrad, Divergence = 0 mrad
 NOED= 12000 meters (39360 feet or 6.5 nautical miles)
 Table values are FOOTPRINT dimensions(feet and meters)

ALTITUDE (feet)	FOOTPRINT	SLANT RANGE (nautical miles, feet, and meters)																			
		1.0 NM	2.0 NM	3.0 NM	4.0 NM	5.0 NM	6.0 NM	7.0 NM	8.0 NM	9.0 NM											
100	FORWARD	841 ft	3900 ft	10500 ft	15100 ft	8980 ft	2900 ft	0 ft	0 ft	0 ft	0 ft	0 ft	0 ft	0 ft	0 ft	0 ft	0 ft	0 ft	0 ft	0 ft	
	AFT	256 m	1190 m	3190 m	4590 m	2740 m	885 m	0 m	0 m	0 m	0 m	0 m	0 m	0 m	0 m	0 m	0 m	0 m	0 m	0 m	0 m
200	FORWARD	658 ft	2380 ft	4870 ft	7950 ft	11500 ft	15400 ft	19600 ft	24000 ft	28600 ft	33000 ft	37600 ft	42200 ft	46800 ft	51400 ft	56000 ft	60600 ft	65200 ft	69800 ft	74400 ft	79000 ft
	AFT	201 m	724 m	1480 m	2420 m	3500 m	4690 m	5960 m	7300 m	8710 m	10100 m	11500 m	12900 m	14300 m	15700 m	17100 m	18500 m	19900 m	21300 m	22700 m	24100 m
300	FORWARD	393 ft	1680 ft	4060 ft	7800 ft	8980 ft	2900 ft	0 ft	0 ft	0 ft	0 ft	0 ft	0 ft	0 ft	0 ft	0 ft	0 ft	0 ft	0 ft	0 ft	
	AFT	120 m	512 m	1240 m	2380 m	2740 m	885 m	0 m	0 m	0 m	0 m	0 m	0 m	0 m	0 m	0 m	0 m	0 m	0 m	0 m	0 m
400	FORWARD	348 ft	1320 ft	2810 ft	4750 ft	7080 ft	9740 ft	12700 ft	15900 ft	19300 ft	22700 ft	26100 ft	29500 ft	32900 ft	36300 ft	39700 ft	43100 ft	46500 ft	49900 ft	53300 ft	
	AFT	106 m	401 m	857 m	1450 m	2160 m	2970 m	3870 m	4850 m	5890 m	6930 m	7970 m	9010 m	10050 m	11090 m	12130 m	13170 m	14210 m	15250 m	16290 m	
500	FORWARD	257 ft	1070 ft	2520 ft	4700 ft	7720 ft	2900 ft	0 ft	0 ft	0 ft	0 ft	0 ft	0 ft	0 ft	0 ft	0 ft	0 ft	0 ft	0 ft	0 ft	
	AFT	78 m	327 m	769 m	1430 m	2350 m	885 m	0 m	0 m	0 m	0 m	0 m	0 m	0 m	0 m	0 m	0 m	0 m	0 m	0 m	
600	FORWARD	237 ft	911 ft	1980 ft	3390 ft	5120 ft	7130 ft	9400 ft	11900 ft	14400 ft	16800 ft	19200 ft	21600 ft	24000 ft	26400 ft	28800 ft	31200 ft	33600 ft	36000 ft	38400 ft	
	AFT	72 m	278 m	602 m	1030 m	1560 m	2170 m	2860 m	3630 m	4400 m	5170 m	5940 m	6710 m	7480 m	8250 m	9020 m	9790 m	10560 m	11330 m	12100 m	
700	FORWARD	190 ft	786 ft	1830 ft	3360 ft	5440 ft	2900 ft	0 ft	0 ft	0 ft	0 ft	0 ft	0 ft	0 ft	0 ft	0 ft	0 ft	0 ft	0 ft	0 ft	
	AFT	58 m	240 m	557 m	1020 m	1660 m	885 m	0 m	0 m	0 m	0 m	0 m	0 m	0 m	0 m	0 m	0 m	0 m	0 m	0 m	
800	FORWARD	179 ft	695 ft	1520 ft	2630 ft	4010 ft	5620 ft	7460 ft	9500 ft	11900 ft	14300 ft	16700 ft	19100 ft	21500 ft	23900 ft	26300 ft	28700 ft	31100 ft	33500 ft	35900 ft	
	AFT	55 m	212 m	464 m	803 m	1220 m	1710 m	2270 m	2900 m	3630 m	4360 m	5090 m	5820 m	6550 m	7280 m	8010 m	8740 m	9470 m	10200 m	10930 m	
900	FORWARD	151 ft	621 ft	1430 ft	2620 ft	4200 ft	2900 ft	0 ft	0 ft	0 ft	0 ft	0 ft	0 ft	0 ft	0 ft	0 ft	0 ft	0 ft	0 ft	0 ft	
	AFT	46 m	189 m	437 m	798 m	1280 m	885 m	0 m	0 m	0 m	0 m	0 m	0 m	0 m	0 m	0 m	0 m	0 m	0 m	0 m	
1000	FORWARD	144 ft	563 ft	1240 ft	2150 ft	3290 ft	4640 ft	6180 ft	7860 ft	9540 ft	11220 ft	12900 ft	14580 ft	16260 ft	17940 ft	19620 ft	21300 ft	22980 ft	24660 ft	26340 ft	
	AFT	44 m	172 m	378 m	656 m	1000 m	1410 m	1880 m	2400 m	2920 m	3440 m	3960 m	4480 m	5000 m	5520 m	6040 m	6560 m	7080 m	7600 m	8120 m	
1100	FORWARD	126 ft	513 ft	1180 ft	2140 ft	3420 ft	2900 ft	0 ft	0 ft	0 ft	0 ft	0 ft	0 ft	0 ft	0 ft	0 ft	0 ft	0 ft	0 ft	0 ft	
	AFT	38 m	156 m	359 m	653 m	1040 m	885 m	0 m	0 m	0 m	0 m	0 m	0 m	0 m	0 m	0 m	0 m	0 m	0 m	0 m	
1200	FORWARD	121 ft	473 ft	1040 ft	1820 ft	2790 ft	3950 ft	5280 ft	6710 ft	8140 ft	9570 ft	10990 ft	12420 ft	13850 ft	15280 ft	16710 ft	18140 ft	19570 ft	20990 ft	22420 ft	
	AFT	37 m	144 m	318 m	555 m	852 m	1200 m	1610 m	2020 m	2430 m	2840 m	3250 m	3660 m	4070 m	4480 m	4890 m	5300 m	5710 m	6120 m	6530 m	
1300	FORWARD	107 ft	437 ft	1000 ft	1810 ft	2890 ft	2900 ft	0 ft	0 ft	0 ft	0 ft	0 ft	0 ft	0 ft	0 ft	0 ft	0 ft	0 ft	0 ft	0 ft	
	AFT	33 m	133 m	305 m	553 m	880 m	885 m	0 m	0 m	0 m	0 m	0 m	0 m	0 m	0 m	0 m	0 m	0 m	0 m	0 m	
1400	FORWARD	104 ft	408 ft	902 ft	1580 ft	2430 ft	3440 ft	4610 ft	5940 ft	7270 ft	8600 ft	9930 ft	11260 ft	12590 ft	13920 ft	15250 ft	16580 ft	17910 ft	19240 ft	20570 ft	
	AFT	32 m	124 m	275 m	481 m	740 m	1050 m	1400 m	1750 m	2100 m	2450 m	2800 m	3150 m	3500 m	3850 m	4200 m	4550 m	4900 m	5250 m	5600 m	
1500	FORWARD	94 ft	381 ft	870 ft	1570 ft	2500 ft	2900 ft	0 ft	0 ft	0 ft	0 ft	0 ft	0 ft	0 ft	0 ft	0 ft	0 ft	0 ft	0 ft	0 ft	
	AFT	29 m	116 m	265 m	479 m	761 m	885 m	0 m	0 m	0 m	0 m	0 m	0 m	0 m	0 m	0 m	0 m	0 m	0 m	0 m	
1600	FORWARD	91 ft	358 ft	795 ft	1390 ft	2140 ft	3050 ft	4090 ft	5130 ft	6170 ft	7210 ft	8250 ft	9290 ft	10330 ft	11370 ft	12410 ft	13450 ft	14490 ft	15530 ft	16570 ft	
	AFT	28 m	109 m	242 m	424 m	654 m	928 m	1250 m	1570 m	1890 m	2210 m	2530 m	2850 m	3170 m	3490 m	3810 m	4130 m	4450 m	4770 m	5090 m	
1700	FORWARD	24 ft	49 ft	73 ft	97 ft	122 ft	146 ft	170 ft	194 ft	219 ft	243 ft	267 ft	291 ft	315 ft	339 ft	363 ft	387 ft	411 ft	435 ft	459 ft	
	WIDTH	7 m	15 m	22 m	30 m	37 m	44 m	52 m	59 m	67 m	75 m	83 m	91 m	99 m	107 m	115 m	123 m	131 m	139 m	147 m	

Table E-5. Laser Footprint Table For: Any Laser System with Beam Divergence < 0.5 mrad
 Table based on: Flat terrain. Buffer = 5 mrad, Divergence = 0 mrad
 NOHD= 10000 meters (328000 feet or 54.0 nautical miles)
 Table values are FOOTPRINT dimensions(feet and meters)

FOOTPRINT FORWARD - distance beyond target.
 FOOTPRINT AFT - distance from target toward aircraft.
 FOOTPRINT WIDTH - total width at target.
 NOTE: --99 indicates an impossible alt./range combination.

ALTITUDE (feet)	FOOTPRINT	SLANT RANGE (nautical miles, feet, and meters)								
		1.0 NM	2.0 NM	3.0 NM	4.0 NM	5.0 NM	6.0 NM	7.0 NM	8.0 NM	9.0 NM
100	FORWARD	6080 ft 1850 m	12200 ft 3700 m	18200 ft 5560 m	24300 ft 7410 m	30400 ft 9260 m	36500 ft 11100 m	42500 ft 13000 m	48600 ft 14800 m	54700 ft 16700 m
	AFT	2650 ft 808 m	5740 m 1420 ft	8990 ft 2720 m	12200 ft 3700 m	15400 ft 4660 m	18600 ft 5660 m	21800 ft 6630 m	25000 ft 7620 m	28200 ft 8660 m
200	FORWARD	1090 ft 332 m	2180 ft 663 m	3270 ft 995 m	4360 ft 1320 m	5450 ft 1665 m	6540 ft 1992 m	7630 ft 2317 m	8720 ft 2650 m	9810 ft 2987 m
	AFT	801 ft 244 m	1602 ft 488 m	2403 ft 733 m	3204 ft 977 m	4005 ft 1250 m	4806 ft 1500 m	5607 ft 1750 m	6408 ft 2000 m	7209 ft 2250 m
300	FORWARD	685 ft 209 m	1370 ft 417 m	2055 ft 624 m	2740 ft 835 m	3425 ft 1042 m	4110 ft 1250 m	4795 ft 1457 m	5480 ft 1662 m	6165 ft 1867 m
	AFT	559 ft 170 m	1118 ft 341 m	1677 ft 512 m	2236 ft 681 m	2795 ft 849 m	3354 ft 1018 m	3913 ft 1187 m	4472 ft 1356 m	5031 ft 1525 m
400	FORWARD	499 ft 152 m	998 ft 304 m	1497 ft 456 m	1996 ft 608 m	2495 ft 760 m	2994 ft 912 m	3493 ft 1064 m	3992 ft 1216 m	4491 ft 1368 m
	AFT	429 ft 131 m	858 ft 262 m	1287 ft 391 m	1716 ft 514 m	2145 ft 637 m	2574 ft 760 m	2993 ft 883 m	3412 ft 1006 m	3831 ft 1129 m
500	FORWARD	393 ft 120 m	786 ft 240 m	1179 ft 356 m	1572 ft 474 m	1965 ft 592 m	2358 ft 710 m	2751 ft 828 m	3144 ft 946 m	3537 ft 1064 m
	AFT	348 ft 106 m	696 ft 211 m	1044 ft 313 m	1392 ft 415 m	1740 ft 517 m	2088 ft 619 m	2436 ft 721 m	2784 ft 823 m	3132 ft 925 m
600	FORWARD	324 ft 99 m	648 ft 198 m	972 ft 297 m	1296 ft 396 m	1620 ft 495 m	1944 ft 594 m	2268 ft 693 m	2592 ft 792 m	2916 ft 891 m
	AFT	293 ft 89 m	586 ft 177 m	879 ft 264 m	1172 ft 352 m	1465 ft 439 m	1758 ft 526 m	2051 ft 613 m	2344 ft 700 m	2637 ft 787 m
700	FORWARD	276 ft 84 m	552 ft 166 m	828 ft 250 m	1104 ft 331 m	1380 ft 415 m	1656 ft 498 m	1932 ft 581 m	2208 ft 664 m	2484 ft 747 m
	AFT	253 ft 77 m	506 ft 152 m	759 ft 228 m	1012 ft 303 m	1265 ft 384 m	1518 ft 465 m	1771 ft 546 m	2024 ft 627 m	2277 ft 708 m
800	FORWARD	240 ft 73 m	480 ft 146 m	720 ft 219 m	960 ft 292 m	1200 ft 363 m	1440 ft 436 m	1680 ft 509 m	1920 ft 582 m	2160 ft 655 m
	AFT	222 ft 68 m	444 ft 133 m	666 ft 200 m	888 ft 266 m	1110 ft 333 m	1332 ft 400 m	1554 ft 467 m	1776 ft 534 m	1998 ft 601 m
	WIDTH	61 ft 19 m	122 ft 37 m	183 ft 56 m	244 ft 74 m	305 ft 93 m	366 ft 111 m	427 ft 130 m	488 ft 148 m	549 ft 167 m

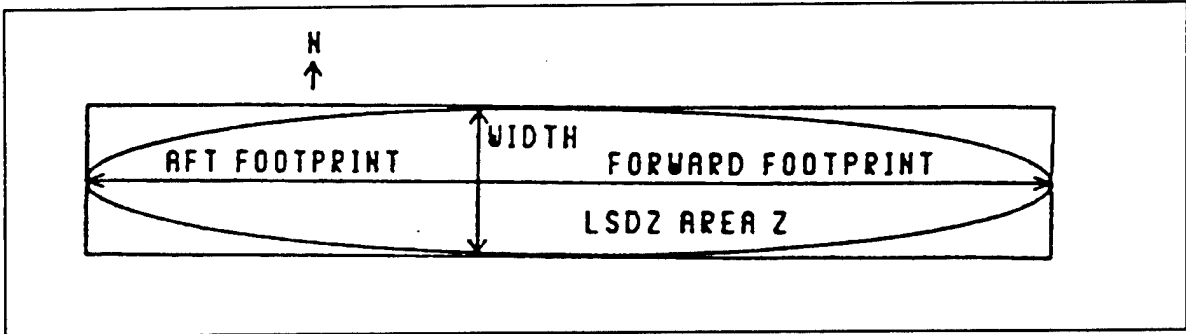

Figure E-4. LSDZ – attack bearing 90°

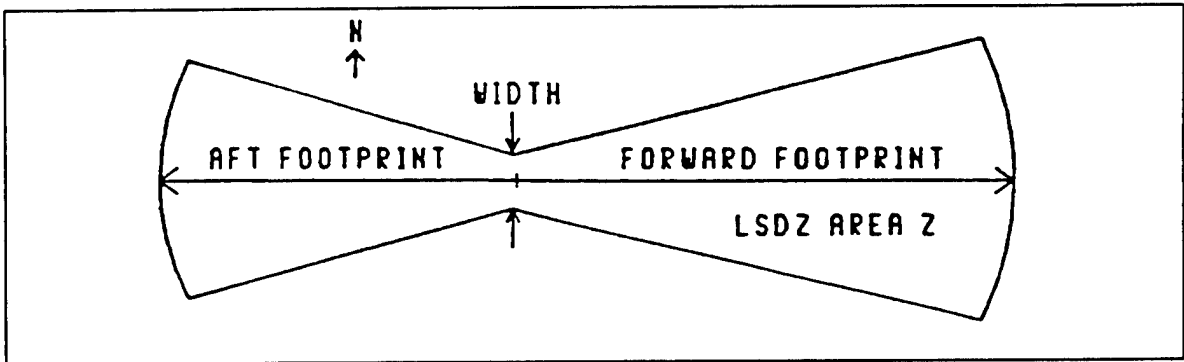

Figure E-5. LSDZ – attack bearing 70 to 110°.

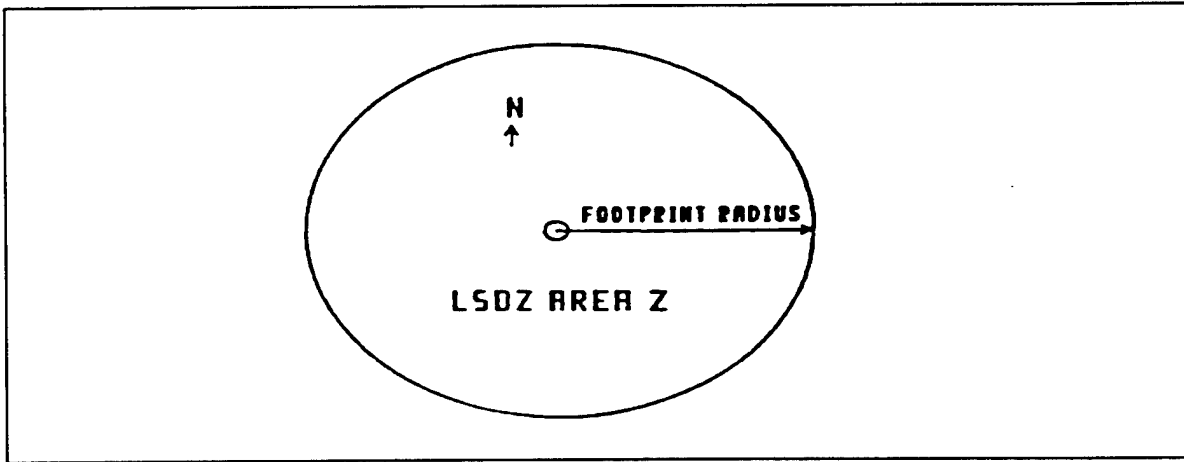

Figure E-6. LSDZ – attack from any direction.

3.3.2.3.2 Example 2 (Level Ground). Referring to Table E-5 for any PAVE SPIKE or PAVE TACK laser fired from 200 feet to 1000 feet above ground level at ranges from 1 to 4 miles, the longest buffered footprint dimensions on level ground are 37,600 feet forward, 9190 feet aft, and 243 feet wide. The areas within these target distances must be restricted as the LSDZ.

3.3.2.4 Unlevel Terrain. Although actual procedures vary on a case-by-case, the following conditions are presented as common.

3.3.2.4.1 Target on Rising Terrain Or Hills Behind Target (Natural Backstop). The condition of targets on rising terrain sometimes lengthens the near boundary and makes the far boundary less restrictive than the level ground condition. Hills behind the targets can act as natural backstops and reduce the size of the forward footprint as rising terrain did (see Figures E-7, E-8, and E-9).

3.3.2.4.2 Falling Terrain in Target Area or Hills in Foreground. This condition will result in longer forward buffered footprints and more restrictive conditions.

3.3.2.4.2.1 Foreground Distances. The height, MSL, or above ground level (AGL) of the laser in reference to the target must be determined for all distances between the laser and target.

3.3.2.4.2.2 Distance Beyond Target. The downward sloping ground beyond the target can greatly extend the forward footprint as shown in Figures E-10 and E-11. If flight profiles are not limited, the forward footprint could be as long as the NOHD.

3.3.3 Specular Reflections. Determine if the reflection from still water can enter uncontrolled air space or hit a hill or ship's structure within the NOHD and beyond the restricted boundaries (see Figure E-12). If this or other specular reflectors appear to be a problem, limit the flight profiles, move the target, or restrict more land or airspace. If still water cannot be avoided or flat specular reflecting surfaces in the area of the footprint cannot be removed, then the aircrew, personnel in other aircraft, ground and shipboard personnel, and the surrounding community need to be considered. If the reflectivity of the specular surface is known, the effective NOHD (distance from laser to reflector plus distance of reflected beam to end of hazard zone) can be reduced by (approximately) the square root of the reflection coefficient. See Appendix G for some reflection coefficients. For each altitude of the aircraft and distance from the specular reflector, a new sphere or linear distance must be calculated for the specular reflection into the surrounding area or air space. Use the worst case results.

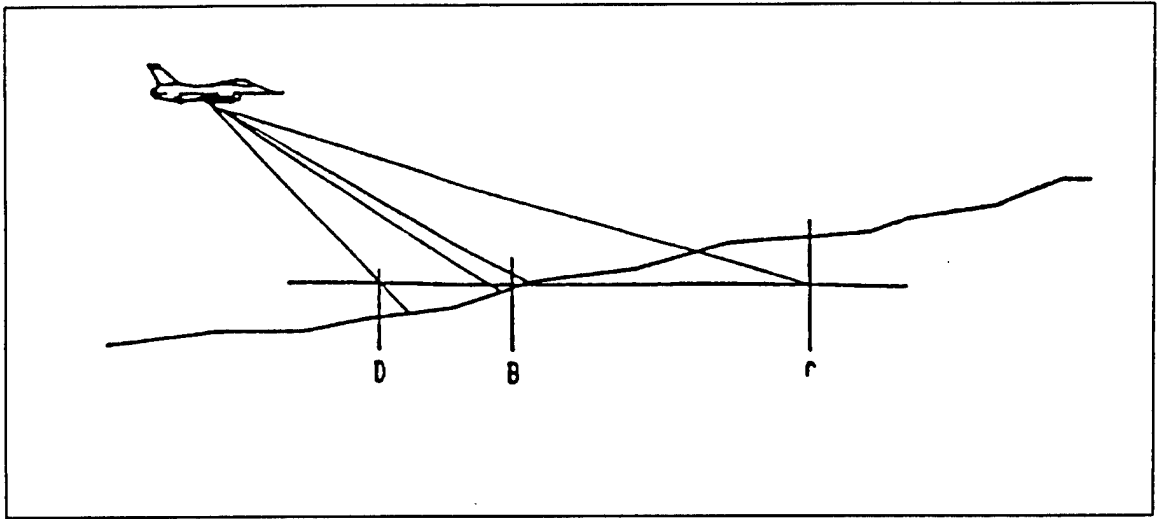

Figure E-7. LSDZ with rising terrain.

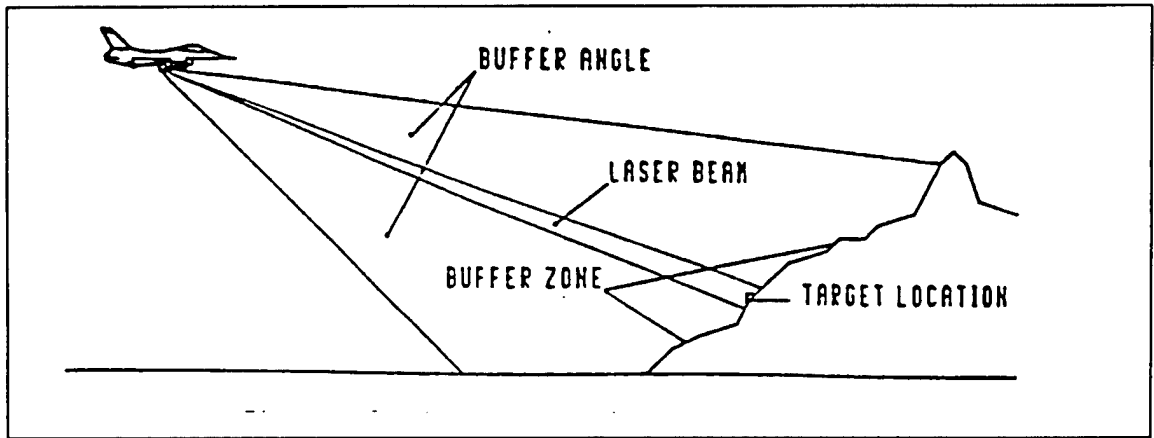

Figure E-8. Natural backstops to control laser beam.

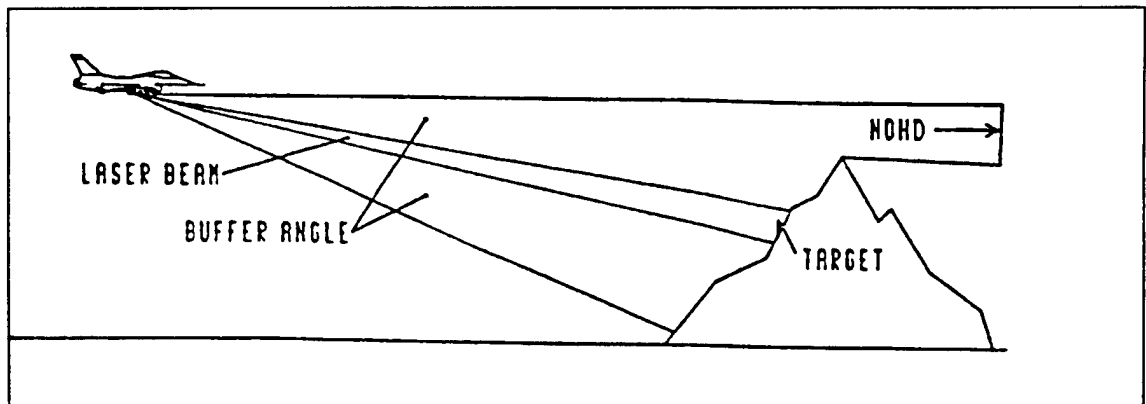

Figure E-9. Insufficient backstop to control laser beam.

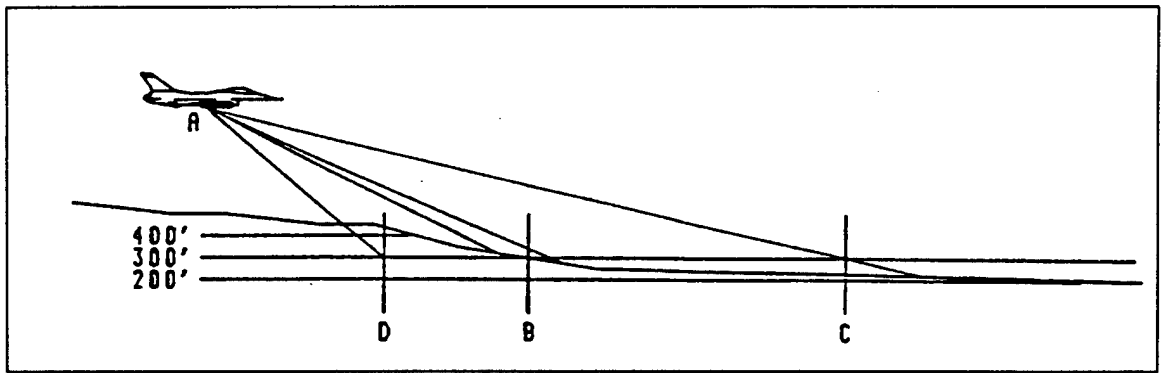

Figure E-10. LSDZ with terrain sloping down. Range is less than NOHD.

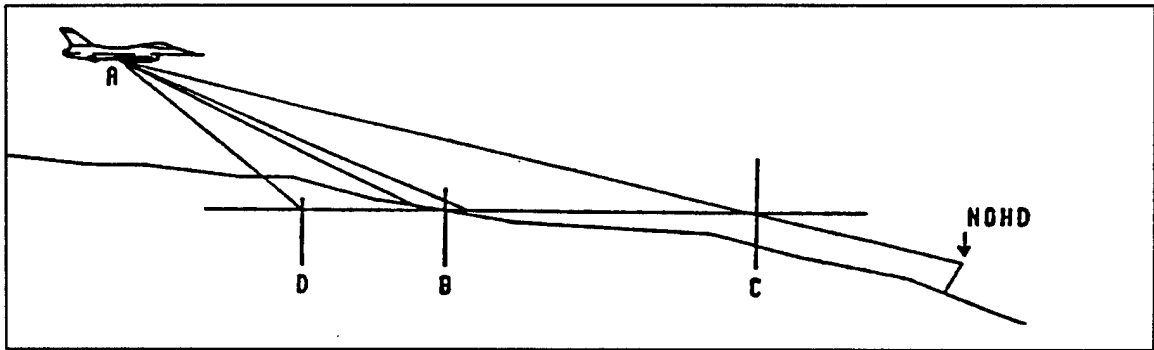

Figure E-11. LSDZ with Terrain sloping down. Range is greater than NOHD.

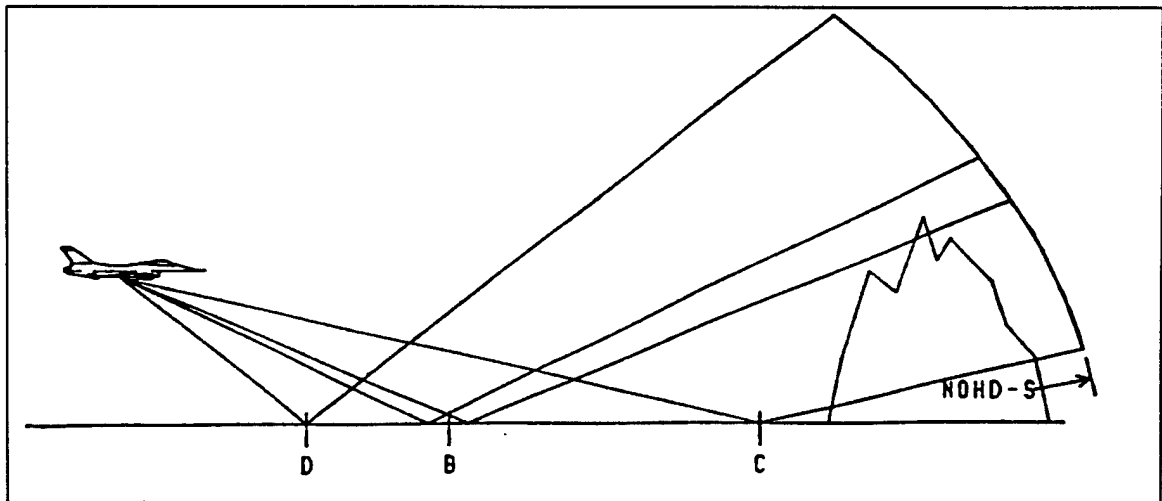

Figure E-12. Reflections from still water with LDZ.

3.3.4 Aircrew. Present policy for most services requires aircrews to wear laser protective eye wear when aircraft are flying in multiple ship formations, targets are not clear of specular surfaces, or ground based lasers are used against aircraft. If the target area is not clear of specular surfaces, and the aircrews lase from distances less than one half the NOHD, aircrews are at risk of eye damage if laser protective eyewear is not used. Possible exposure situations to aircrews from specular reflectors are shown in Figures E-13 and E-14.

3.3.5 Ground Personnel, Shipboard Personnel, Other Aircraft, and Surrounding Community. If flat specular surfaces are near the target, the laser beam can be redirected in any direction as shown in Figures E-15 and E-16. The LSDZ should then be extended to a hemisphere or portion of a hemisphere with a distance from the specular reflector equal to the NOHD minus the minimum lasing distance from the laser to specular reflector. As with the cases described previously, natural backstops and terrain may alter the shape of this area. Airspace over the range, personnel on ships superstructure, or land based high structures may be at an unacceptable risk.

3.3.6 Hazard Distances From Various Reflective Surfaces. Reflection distances can be calculated from the information in Appendix G.

3.4 Footprint Determinations. If the range is small and is the controlling factor, ascertain the flight profiles from the land size by

- determining desired target location,
- outlining controllable restricted range area,
- measuring distance from target to range boundaries, and
- using footprint tables or calculate flight profiles which would not cause the LSDZ to exceed the range boundaries.

For both ground based lasers and airborne lasers, the problem can be broken into two constraints: (1) the buffered footprint does not exceed the available controlled area between the target and the laser (near boundary), and (2) the buffered footprint does not exceed the available controlled area beyond the target (far boundary).

3.4.1 Ground Based Lasers. Determine the ability to keep the buffered laser footprint vertically and horizontally within the restricted boundaries.

3.4.1.1 Vertical Buffer Far Boundary. Addressing the far boundary constraint first, Figure E-17 illustrates the geometry of the problem. First determine the available buffer above and below the target out to the edge of the backstop, where

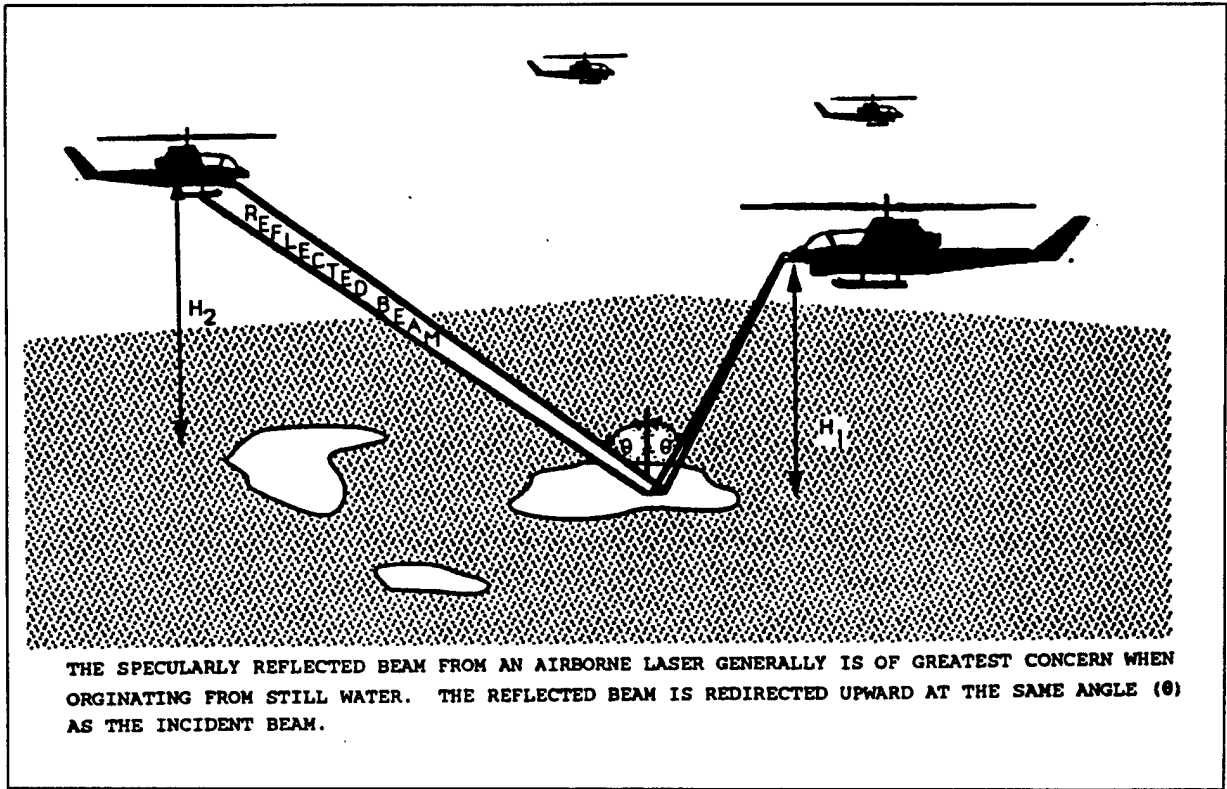

Figure E-13. Example of airborne laser beam reflection.

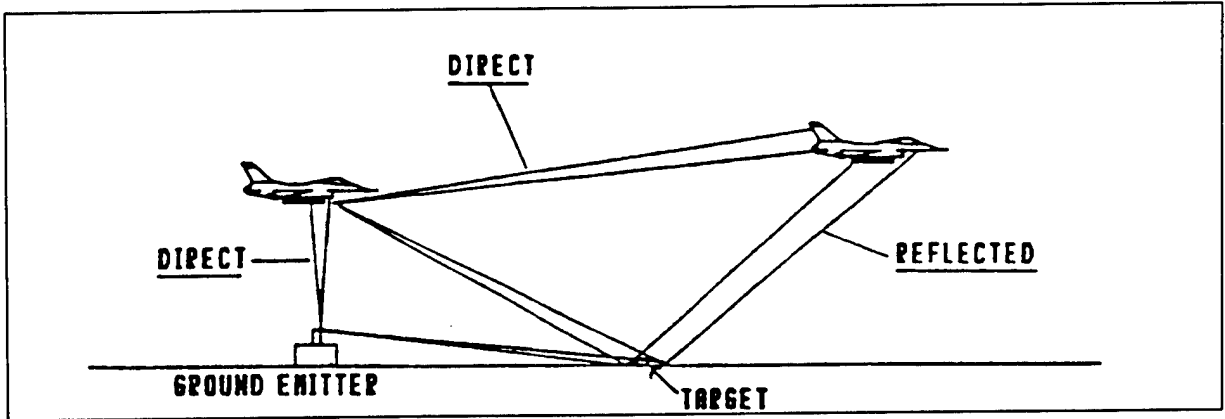

Figure E-14. Potential exposure modes.

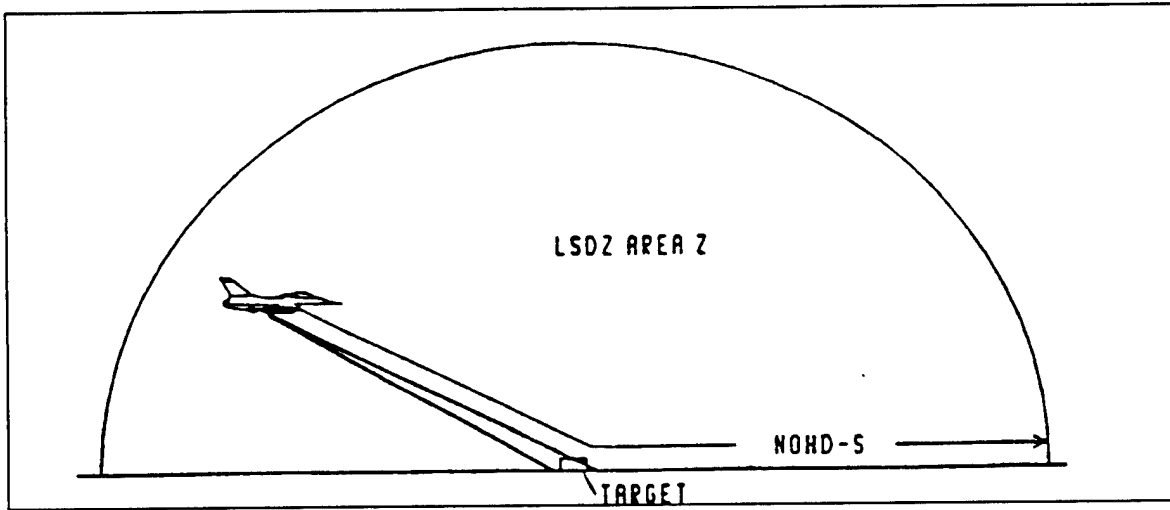

Figure E-15. Reflections from flat specular surface – side view.

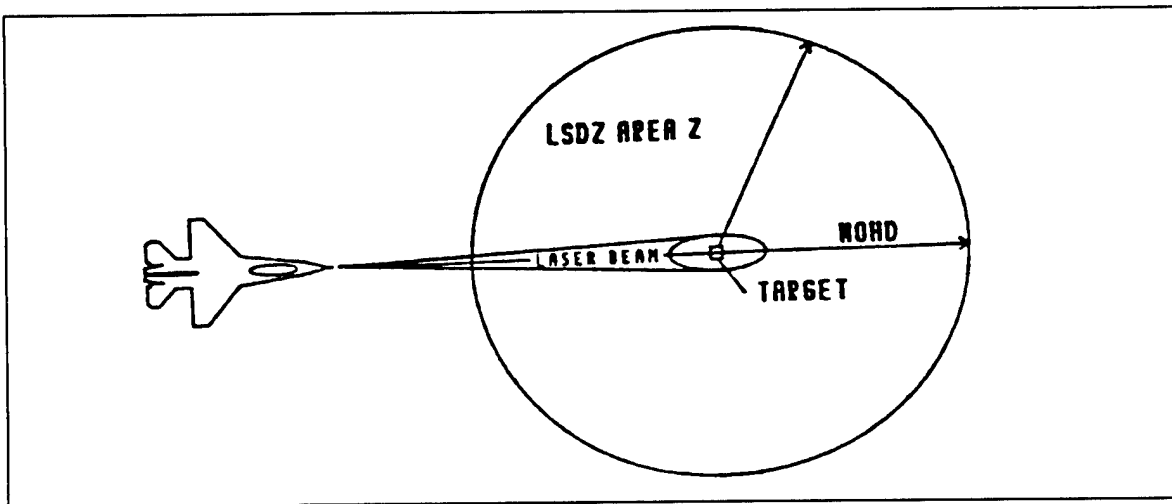

Figure E-16. Reflections from flat specular surface – top view.

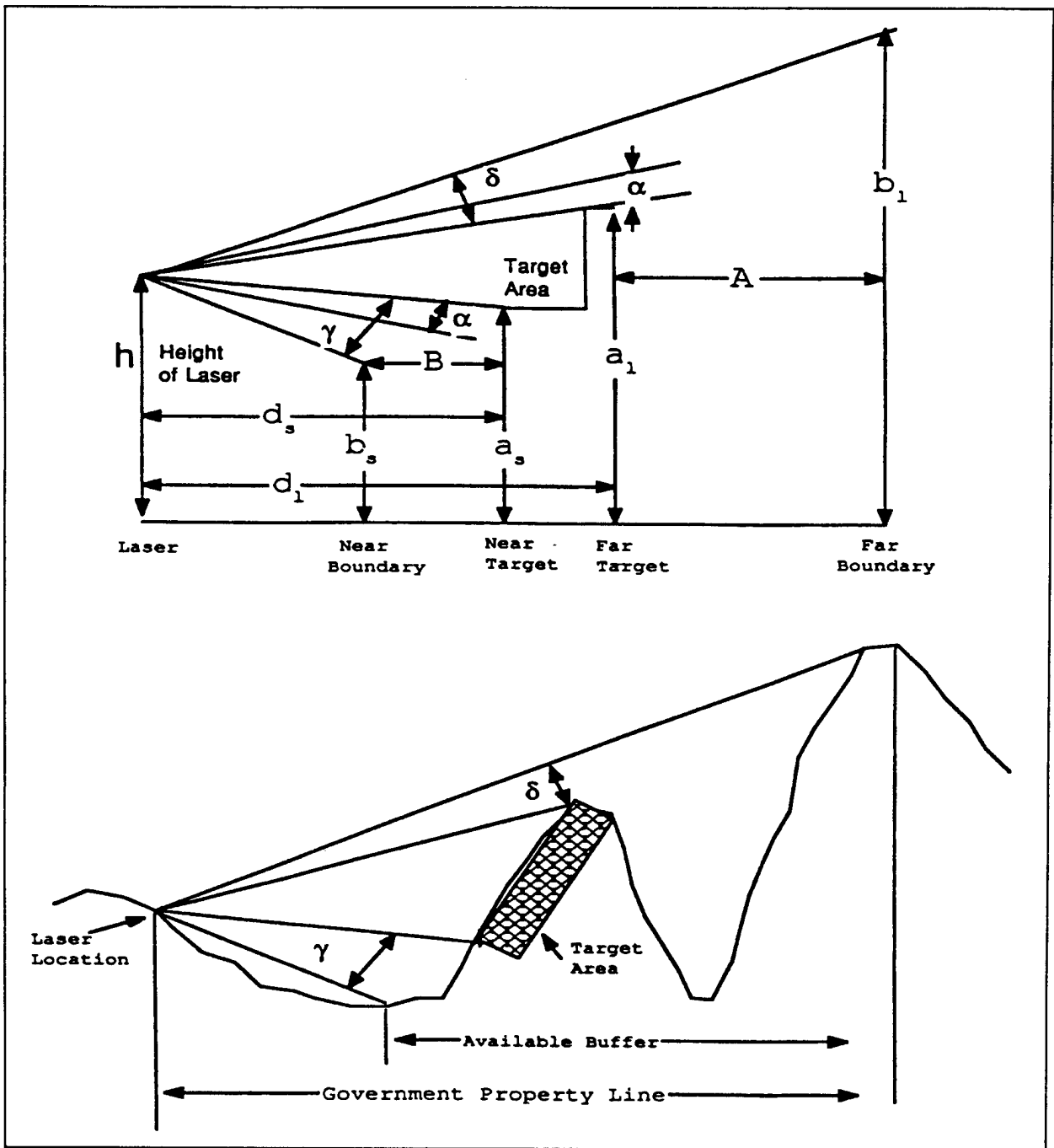

Figure E-17. LSDZ geometry and vertical buffer.

α = buffer angle plus beam divergence on either side of the laser line of sight (LOS). For systems listed in Table A-1, the beam divergence is extremely small compared to the buffer angle, so the beam divergence may be ignored.

δ = available vertical buffer angle between laser LOS to target and laser LOS to backstop.

h = altitude of laser

a_1 = altitude of far target

b_1 = altitude of far boundary

d_1 = horizontal distance on surface from laser to furthest target

A = distance from target to far boundary of LSDZ (backstop)

The angle δ may be calculated from

$$\delta = \arctan((b_1 - h)/(d_1 + A)) + \arctan((h - a_1)/d_1)$$

As long as the angle δ remains greater than angle α , the beam is safely contained vertically within the designated LSDZ.

3.4.1.2 Vertical Buffer Near Boundary. Similarly for the near boundary,

α = buffer angle plus beam divergence on either side of the laser LOS. For systems listed in Table A-1, the beam divergence is extremely small compared to the buffer angle, so the beam divergence may be ignored.

γ = vertical angle from either side of the laser, LOS to the near edge of LSDZ (backstop) between the laser and the target.

h = altitude of laser

a_s = altitude of nearest target

b_s = altitude of near boundary

d_s = horizontal distance on surface from laser to nearest target

B = distance from target to near boundary of LSDZ (backstop)

The vertical angle γ may be calculated from

$$\gamma = \arctan((h - b_s)/(d_s - B)) + \arctan((a_s - h)/d_s)$$

As long as the angle γ remains greater than the angle α , the beam is safely contained vertically within the designated LSDZ.

3.4.1.3 Horizontal Buffer. See Figure E-18. Available buffer to the left and the right of the target out to the backstop may be calculated

$$AB = \arctan((FPN - EBN)/(FPE - EBE)) - \arctan((FPN - TN)/(FPE - TE))$$

where

AB = available buffer angle in radians left and right of target out to the backstop.
FPN = laser firing position north coordinate in meters
EBN = edge of backstop north coordinate in meters
FPE = laser firing position east coordinate in meters
EBE = edge of backstop east coordinate in meters
TN = edge of target north coordinate in meters
TE = edge of target east coordinate in meters

As long as the angle AB is greater than angle α and is negative for the right edge of the backstop and positive for the left edge of the backstop, the beam is safely contained horizontally within the designated LSDZ.

3.4.2 Airborne Laser with Target on Level Ground. For airborne laser buffer geometry at ground level, see Figure E-19.

3.4.2.1 Aircraft Minimum Altitude. The minimum laser altitude (h) relative to the target to keep buffered laser footprint within the far boundary when at slant range (R) from target is

$$h = R \sin(\arcsin((R/A) \sin(\alpha)) + \alpha)$$

the minimum altitude relative to target to keep buffered laser footprint within the near boundary when at slant range R from target is

$$h = R \sin(\arcsin((R/B) \sin(\alpha)) - \alpha)$$

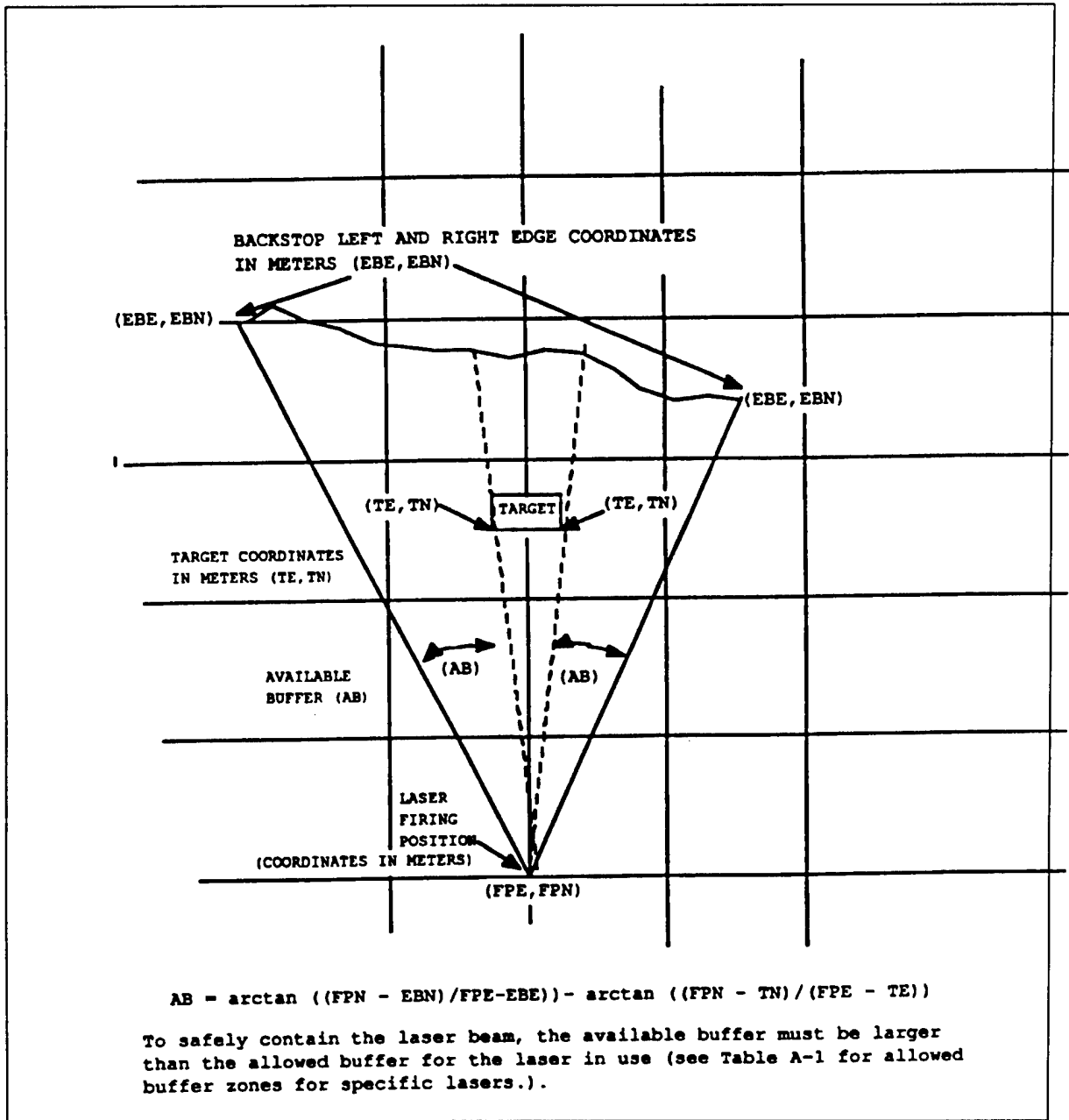

Figure E-18. Calculation of available buffer versus allowed buffer.

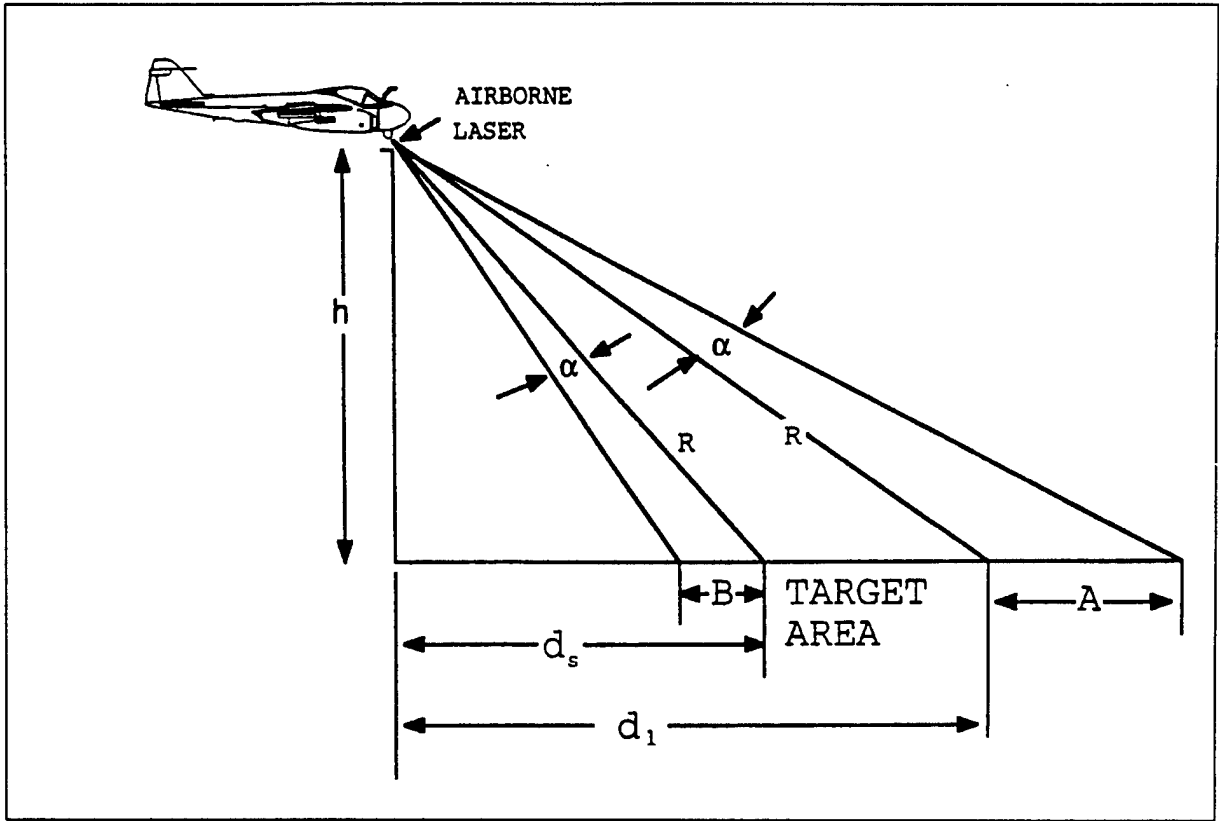

Figure E-19. Airborne laser buffer geometry – level ground.

where

R = slant range from laser to target

α = buffer angle plus beam divergence either side of laser LOS. For systems listed in Table A-1 of Appendix A, the beam divergence is extremely small compared to the buffer angle and hence the beam divergence may be ignored.

A = distance from target to far boundary of LSDZ

B = distance from target to near boundary of LSDZ

h = altitude of laser relative to target surface

HL = altitude of laser above Mean Sea Level

HT = height of target above Mean Sea Level

Choose whichever h is the higher number and assign it as the safe altitude for lasing at range R. If altitude is altitude above mean sea level then the required laser altitude is

$$HL = h + HT$$

Repeat this calculation for every nautical mile (or fraction of a mile depending on the risk) starting at about 12 nautical miles up to and beyond the target. Then plot the results. Remember as you pass over the target that the far and near boundary definitions reverse. A typical flight profile is plotted in Figure E-20.

3.4.2.2 Left and Right Hand LSDZ. The width of the right hand and left hand LSDZ width (see Figure E-3) are calculated as

$$s = R \times \alpha$$

s = left hand LSDZ width or right hand LSDZ width

R = slant range from laser to target

α = assigned buffer angle plus beam divergence on either side of the laser LOS. For systems listed in Table A-1, the beam divergence is small compared to the buffer angle and may be ignored.

3.4.2.3 Airborne Laser with Target on Sloping Ground. Altitudes to keep buffered laser footprint within near or far boundary LSDZ can be calculated as

3.4.2.3.1 Buffered Footprint. See Figure E-2.

HT = altitude of target above mean sea level

h = altitude of laser above target

HL = altitude of laser above mean sea level = h + HT

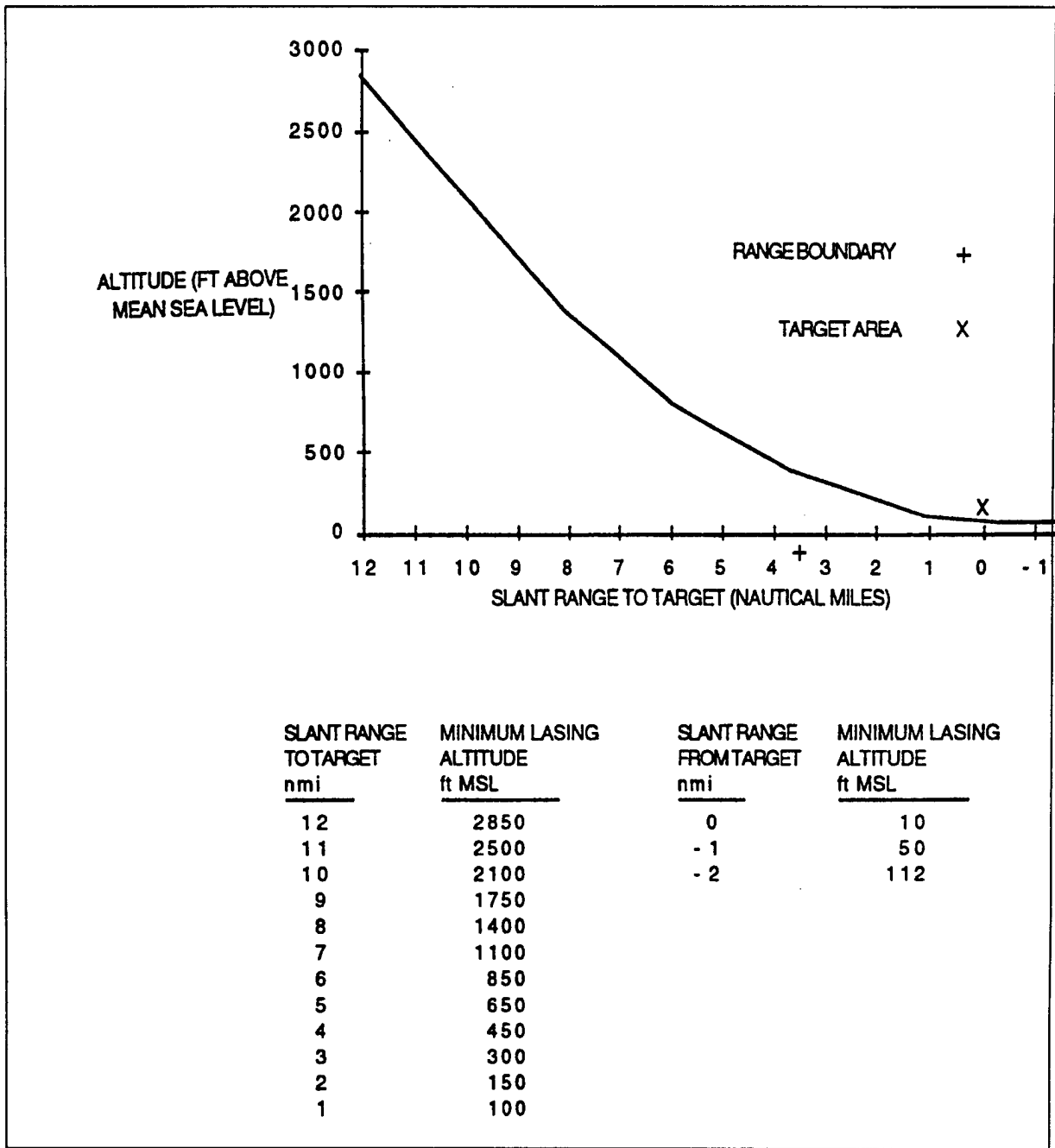

Figure E-20. Example laser aircraft flight profile.

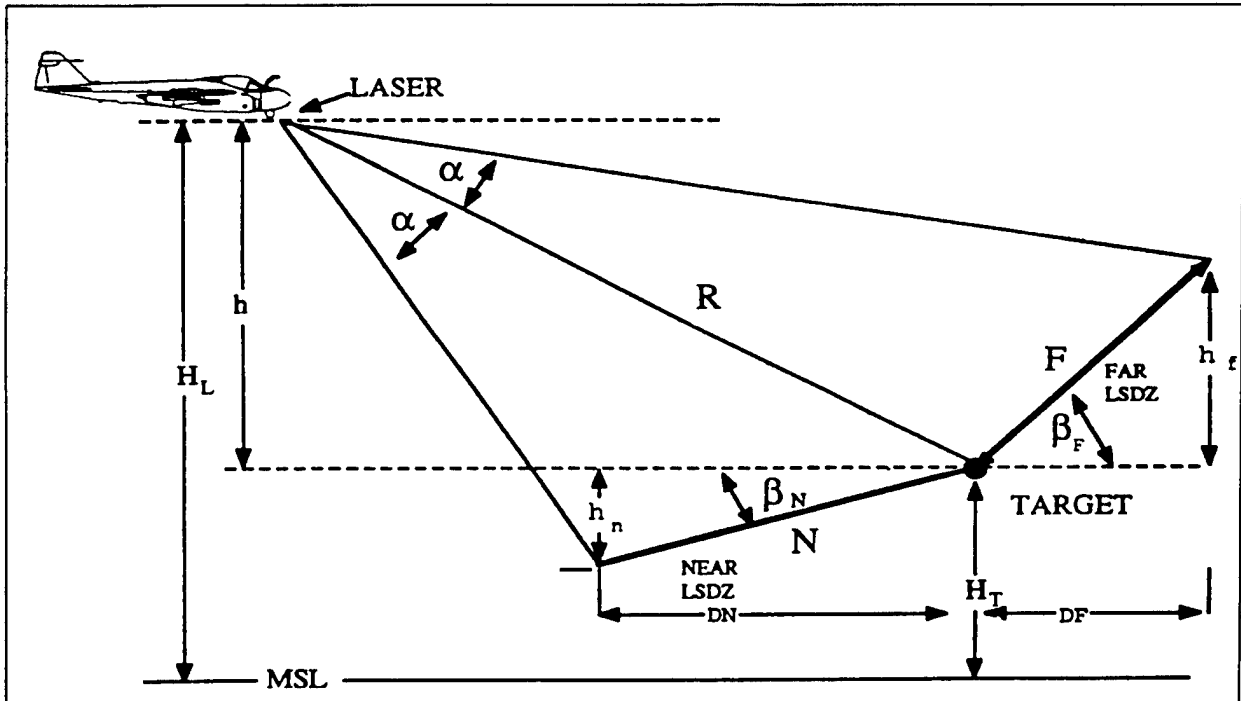

Figure E-21. Laser target on sloping terrain.

h_n = height of near boundary above or below target

h_f = height of far boundary above or below target

DN = horizontal distance from target to near boundary

DF = horizontal distance from target to far boundary

N = slant range distance from near edge of near target to edge of near boundary = square root of the sum of the squares of h_n and DN

F = slant range distance from far edge of far target to edge of far boundary = square root of the sum of the squares of h_f and DF

β_F = declination or elevation angle from horizontal between edge of far target and edge of far boundary = $\arctan(h_f/DF)$ (positive number for far boundary higher than the target and negative number for far boundary lower than target)

β_N = declination or elevation angle from horizontal between edge of near target and edge of near boundary = $\arctan(h_n/DN)$ (positive number for near boundary lower than target and negative number for near boundary higher than target)

h_n = height of near boundary above or below target

R = slant range from laser to target

α = assigned buffer angle plus beam divergence. For systems listed in Table A-1 the beam divergence is small compared to the buffer angle and hence may be ignored.

3.4.2.3.2 For Far Target

$$h = R \sin(\arcsin((R/F) \sin(\alpha)) - \beta_F + \alpha)$$

and

$$HL = R \sin(\arcsin((R/F) \sin(\alpha)) - \beta_F + \alpha) + HT$$

3.4.2.3.3 For Near Target

$$h = R \sin(\arcsin((R/N) \sin(\alpha)) - \beta_N - \alpha)$$

and

$$HL = R \sin(\arcsin((R/N) \sin(\alpha)) - \beta_N - \alpha) + HT$$

Choose whichever h is the higher number and assign it as the safe altitude for lasing at range R . Repeat this calculation for every nautical mile (or fraction of a mile depending on the risk) starting at about 12 nautical miles up to and beyond the target. Then plot the results. Remember as you pass over the target that the far and near boundary definitions reverse. A typical flight profile is plotted on Figure E-20.

3.4.2.3.4 Left and Right Hand LSDZ. The width of the right hand and left hand LSDZ are calculated as

$$s = R \times \alpha$$

s = left hand LSDZ width or right hand LSDZ width

R = slant range from laser to target

α = assigned buffer angle plus beam divergence on either side of the laser LOS. For systems listed in Table A-1, the beam divergence is small compared to the buffer angle and may be ignored.

APPENDIX F

DOD LASER RANGE SURVEY CHECKLISTS

APPENDIX F

DOD LASER RANGE SURVEY CHECKLISTS

1.0 Scope

This appendix provides presurvey, survey, and survey report checklist examples that may be used by tailoring or adding items as needed for local situations such as training operations, research, development, or testing.

2.0 Checklists

Sample checklists are enclosed.

LASER RANGE PRESURVEY CHECKLIST

RANGE/AREA NAME: _____ DATE: _____
LOCATION (GRID COORDINATES) _____

ADDRESS: _____ PLANNED SURVEY _____
DATE: _____

LAST SURVEY DATE _____

PHONE:(DSN) _____ PERFORMED BY: _____

(COMM) _____ RANGE POC: _____

USER POCs: _____

DATA COLLECTION

DOCUMENTS

RANGE SOP _____

RANGE LASER DIRECTIVES _____

OLD SURVEY REPORT _____

MAPS OF

RANGE BOUNDARIES _____

RESTRICTED AIR SPACE _____

LASER OPERATING LOCATIONS _____

TOPOGRAPHY _____

TGT LOCATIONS _____

TYPES OF LASER OPERATIONS

AIRBORNE LASER OPERATIONS _____

GROUND BASED LASER OPERATIONS _____

SHIP MOUNTED LASER OPERATIONS _____

SYSTEMS TO BE USED ON RANGE

TRAM _____ LTD _____ MULE _____ LANTIRN _____ NOS _____

LD-82 _____ GVLLD _____ M60A2 _____ PAVE TACK _____ GVS-5 _____

M60A3 _____ M1A1 _____ M551A1 _____ PAVE SPIKE _____ MILES _____

TADS _____ LAAT _____ CLD _____ PAVE KNIFE _____ F/A-18 _____

MMS _____ OTHERS (LIST) _____

TARGET NAME

GRID COORDINATES

1. _____

2. _____

3. _____

4. _____

5. _____

6. _____

7. _____
8. _____
9. _____
10. _____

LASER OPERATOR/FIRING POSITIONS GRID COORDINATES
FOR TARGET #?

1. _____
2. _____
3. _____
4. _____
5. _____
6. _____
7. _____
8. _____
9. _____
10. _____

FORWARD OBSERVER POSITIONS GRID COORDINATES
FOR TARGET #?/LASER #?

1. _____
2. _____
3. _____
4. _____
5. _____
6. _____
7. _____
8. _____
9. _____
10. _____

A. Does the range have established run in headings for aircraft?

Yes ___ No ___

If Yes, what are they?

B. Will more targets be added?

Yes ___ No ___

If yes, where? (grid coordinates)

C. Are there manned positions on the range?

Yes ___ No ___

If yes, where? (grid coordinates)

D. Are there any conditions off the range that need to be addressed?

Yes ___ No ___

If yes, what?

E. Any other changes _____

F. Comments _____

REVIEW OF RANGE SOP and/or LASER SAFETY INSTRUCTION

Does SOP or Laser Safety Instruction specify:

(a) Permissible aircraft flight profiles and run-in headings for specified targets or target areas.

Yes__ No__

(b) Permissible ships headings and safe firing zones for specified targets or target areas.

Yes__ No__

(c) Permissible ground based laser operating positions and/or areas for specified targets or target areas. Yes__ No__

(d) Hazard areas to be cleared of non-operating personnel (road blocks if required).

Yes__ No__

(e) Operating personnel locations (indicating those requiring eye protection). Yes__ No__

(f) Types of surveillance to be used to ensure a clear range. Yes__ No__

(g) Radio frequencies for communication where appropriate.

(h) Firing log/schedule is kept by the range officer in accordance with DOD safety and health record keeping regulations. Yes__ No__

(i) Laser systems will not be activated until the target has been positively identified.

Yes__ No__

(j) All class 3 and 4 lasers shall not be directed above the horizon unless coordinated with all DOD components including US Space Command ((DSN 268-4496, (719)474-4496)) and regional service rep to FAA when lasing outside restricted air space. Has coordination been completed? Yes__ No__

(k) For ground based lasers, all unprotected personnel must remain behind the laser operator. Are these instructions in place? Yes__ No__

(l) Requirement that personnel in other aircraft in the restricted cone around the laser line of sight have eye protection of the proper wavelength and optical density as specified in appendix A of the DOD Laser Range Safety Manual for the specific system or as approved by the laser safety specialists for that DOD component. Yes__ No__

(m) Are there specific written requirements for prebriefing all participants in laser exercises to ensure that remote or wingman laser designators are not located within the field of detection of weapons systems or sensors (for example, laser guided munitions, laser spot trackers, NVGs). All tactics must be planned to ensure that the angle between the laser designator and laser guided munitions is such that the munitions cannot home on the laser source or scattered radiation from the laser platform. Yes__ No__

RANGE LASER SITE SURVEY

1. Laser Safety Officer

Address

Phone (DSN)

2. Is there a laser safety officer on range during laser operations?

Yes ___ No ___

3. Have all of the range personnel involved with laser operations had laser safety training?

Yes ___ No ___

4. Is there a medical surveillance program in place? Yes ___ No ___

5. For lasers not listed in Appendix A, have all of the lasers being used on the range been evaluated by the specific service agency in Chapter 1, subparagraph 1.2.1? Yes ___ No ___

5. a. Does the range laser safety officer have

(1) safety data Yes ___ No ___

(2) procedural information from operational manuals Yes ___ No ___

(3) data on completed recommended actions in the evaluation report from the service agency? Yes ___ No ___

5. b. Has the range laser safety officer been provided with adequate planned tactics to ensure laser employment in compliance with range instructions? Yes ___ No ___

6. Is the range adequately controlled to prevent unauthorized entry? Yes ___ No ___

7. Are laser warning signs posted at the range boundaries and at the entrance?

Yes ___ No ___

8. Where necessary, are there barricades with laser warning signs? Yes ___ No ___

9. If necessary, are the laser warning signs multilingual? Yes ___ No ___

10. Are the targets made of a non-reflecting material for the laser wavelengths being used on the ranges? Yes ____ No ____

11. Are the target and target areas free of specular reflectors? Yes ____ No ____

12. Is there a protective eyewear training, inspection and replacement program in place?
Yes ____ No ____

13. Are all of the personnel who must be on the range during laser operations equipped with the proper eye protection? Yes ____ No ____

14. Is a laser operations log or schedule containing the date, time, and heading of all laser operations being kept? Yes ____ No ____

15. Is there two-way communication between the range laser safety officer, laser system operators, and range personnel? Yes ____ No ____

16. Describe the surveillance of the range.

RANGE SURVEY REPORT

Note: This report may require sign-off by the Service Laser Safety Authority.

RANGE/AREA NAME:

SURVEY SUMMARY

Date Survey was completed _____

Applicable Regulations _____

Range controlled by _____

Survey completed by (Name/Organization)

Dates of operations for which survey is valid _____

Other Pertinent Information _____

SURVEY RESULTS

1. Degree of compliance with applicable regulations

2. Safety deficiencies that must be corrected before approving range for laser use:

RECOMMENDED ACTIONS

1. Corrective actions for existing deficiencies

2. Ground Laser Restrictions - Description of Laser Surface Danger Zones (LSDZ)

3. Aircraft Mounted Lasers - Description of Laser Surface Danger Zones (LSDZ)

4. Recommended operating procedures/range regulations

5. Recommended laser eye protection

6. Controls for protection from reflected laser beams

7. Recommended Training

8. Recommended prebriefs for

(1) laser users _____

(2) laser range personnel _____

APPENDIX G

SPECULAR REFLECTION

APPENDIX G

SPECULAR REFLECTION

1.0 Scope

This appendix provides guidance information on specular reflection hazards.

2.0 Applicable Documents

Van De Merwe, Willem P. and Wesley J. Marshall. "Hazardous Ranges of Laser Beams and Their Reflections from Targets." Applied Optics, vol. 25, no. 5, 1 March 1986.

3.0 Specular Reflection Characteristics

The amount of laser energy reflected from a specular surface and the divergence of the reflected laser beam are dependent on

- reflectivity and index of refraction of the material at the laser wavelength,
- polarization of the laser beam,
- angle of incidence of the laser beam,
- size of the specular reflector relative to the size of the laser spot on the reflector,
- number of reflective surfaces, and
- curvature of the reflecting surface.

3.1 Flat Reflectors. A flat specular surface is one that retains a collimated reflected beam.

Examples are

- standing water,
- flat glass,
- flat plexiglass,
- imaging optical systems,
- corner cube reflectors, and
- flat mirror-like chrome bumpers.

3.2 Hazardous Ranges of Reflected Laser Beam. The amount of reflected laser energy and the resultant hazard distance from a specular reflector are dependent on the factors provided in Paragraph 3.0.

A specular reflector cross section that is smaller than the cross section of the incident laser beam will only reflect a proportional amount of the laser energy. With small size reflectors, diffraction effects may also be present, resulting in a larger divergence of the laser beam.

Normally a pane of glass will reflect from both the front and back surface; however, the reflected beams are seldom co-linear.

Curved specular reflectors (see Table 6-1) will diverge most laser beams, so they generally present no hazard beyond a few meters from the reflector. For this reason, personnel in laser restricted areas should wear laser eye protection with curved lenses.

3.2.1 Reflection from Reflector Larger Than Cross Section of Incident Laser Beam. Figures 6-7 and G-1 show possible laser reflection hazards from standing water, while Figure G-2 depicts the possible laser reflection hazard from specularly reflecting objects in random orientations. Shown in Figure G-3 is a worst case example of reflectance from both the front and back surfaces of a flat glass plate. Figures G-4 and G-5 show values of reflectance for fresh and salt-water surfaces. In ascertaining the hazardous range of the reflective laser energy, the second surface reflections are usually ignored for distances beyond a few meters from the reflector. Neglecting second surface reflections, the following equation may be used to determine the hazardous range of reflected laser energy in situations similar to those shown in Figure 6-7.

$$\begin{aligned} \text{NOHR} &= H2/\cos(\theta) = \text{NOHD} \times (\%P \times R_{\parallel} + \%N \times R_{\perp})^{1/2} - H1/\cos(\theta) \\ &= \text{NOHD} \times [\%P(\tan^2(\theta-\theta'))/(\tan^2(\theta+\theta')) + \%N(\sin^2(\theta-\theta'))/(\sin^2(\theta+\theta'))]^{1/2} - H1/\cos(\theta) \end{aligned}$$

where

NOHR = Nominal Ocular Hazard Distance from Reflector

H1 = altitude of laser

H2 = altitude of observer viewing reflected laser beam

θ = angle incident and reflected laser beam makes with a line perpendicular to the reflecting surface (angle of incidence) = $\arctan(D1/H1)$ for a flat reflector on flat ground

D1 = horizontal distance from laser to reflector

θ' = angle of refracted beam in a reflecting media = $\arcsin(\theta/n)$

n = index of refraction of reflecting media

%P = fraction of laser beam polarized parallel to the plane of incidence

%N = fraction of laser beam polarized perpendicular to plane of incidence

NOHD = Nominal Ocular Hazard Distance (see Table A-1 for typical distances)

$R_{||}$ = Parallel polarization reflection coefficient = $(\tan^2(\theta - \theta')) / (\tan^2(\theta + \theta'))$

R_{\perp} = Perpendicular polarization reflection coefficient = $(\sin^2(\theta - \theta')) / (\sin^2(\theta + \theta'))$

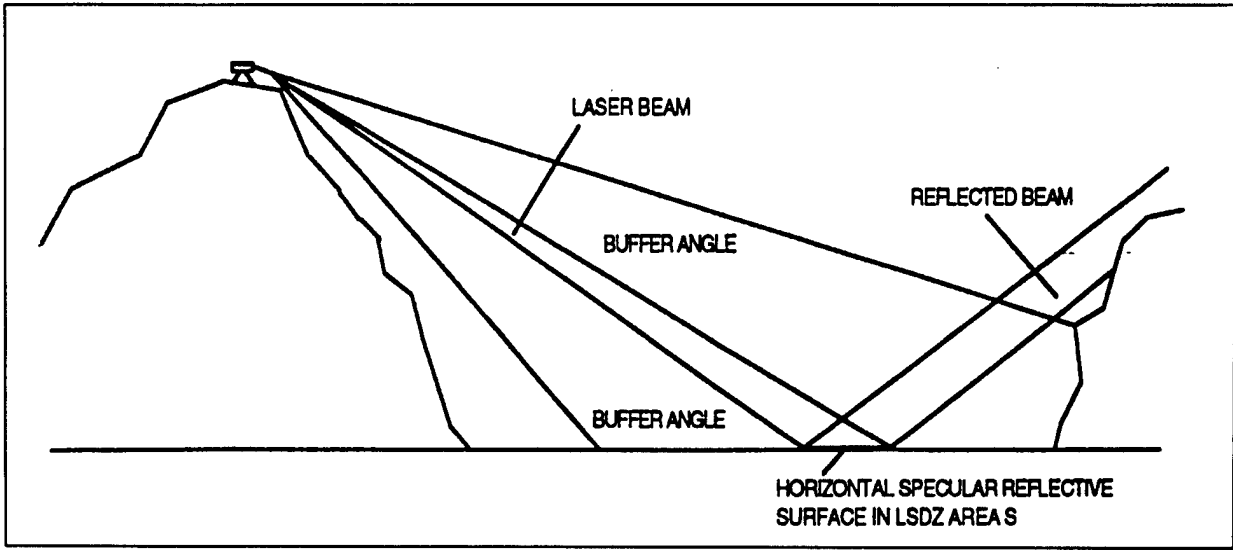

Figure G-1. LSDZ with specular reflections from standing still water.

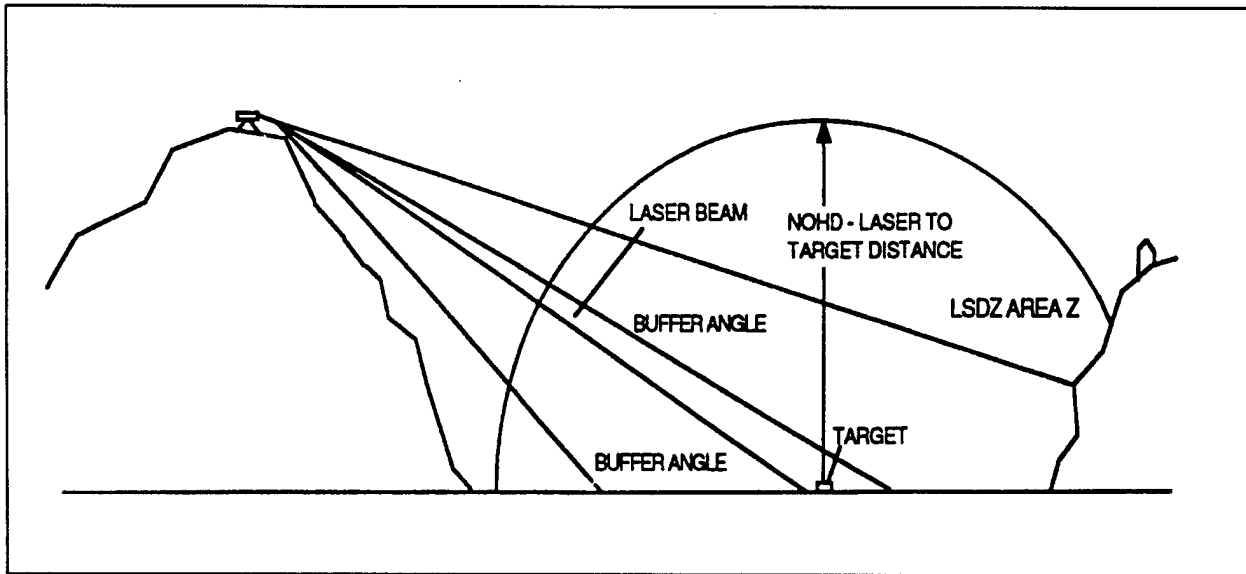

Figure G-2. LSDZ with specular reflective target - side view.

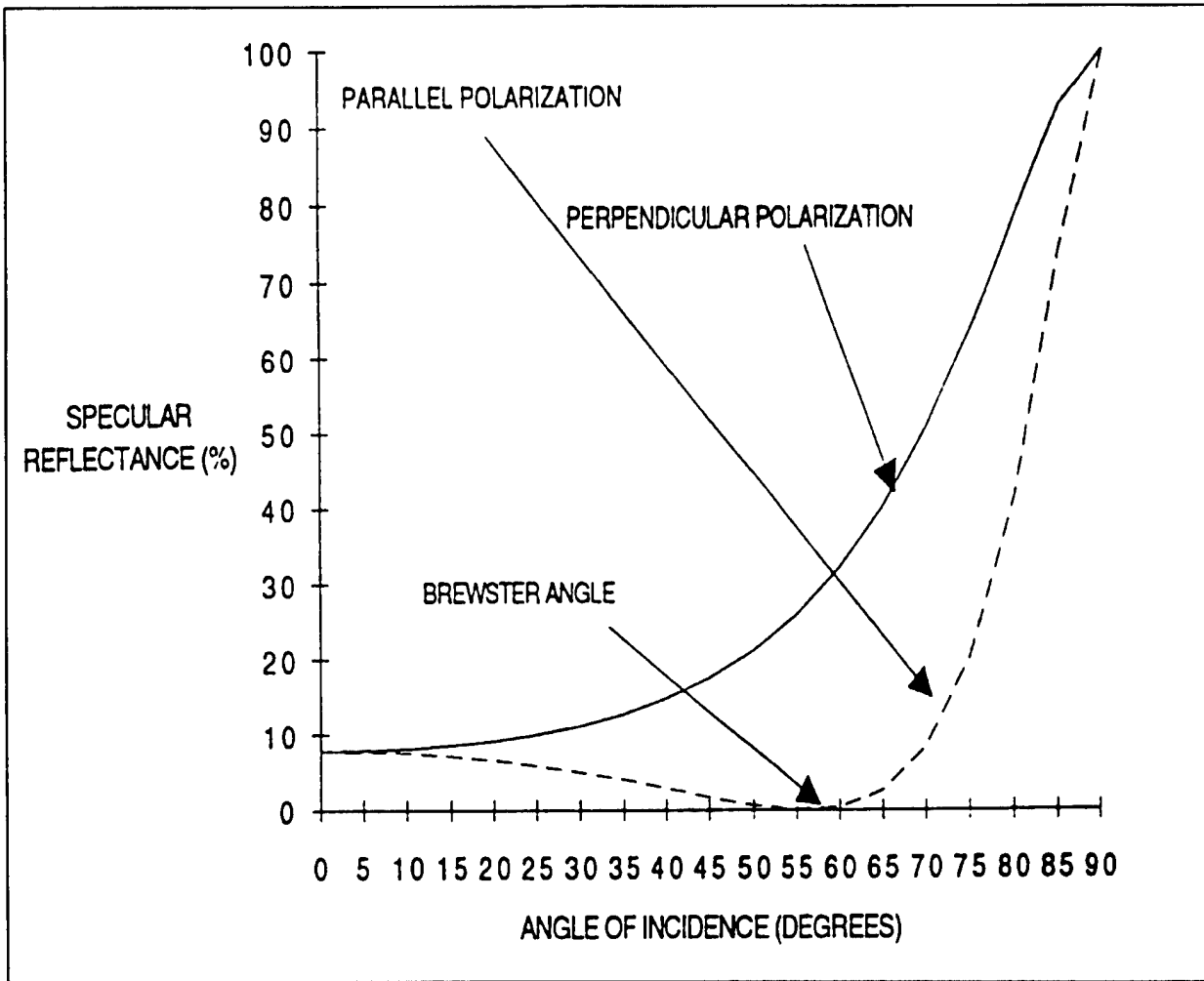

Figure G-3. Specular reflectance from both surfaces of plate glass (index of refraction = 1.5).

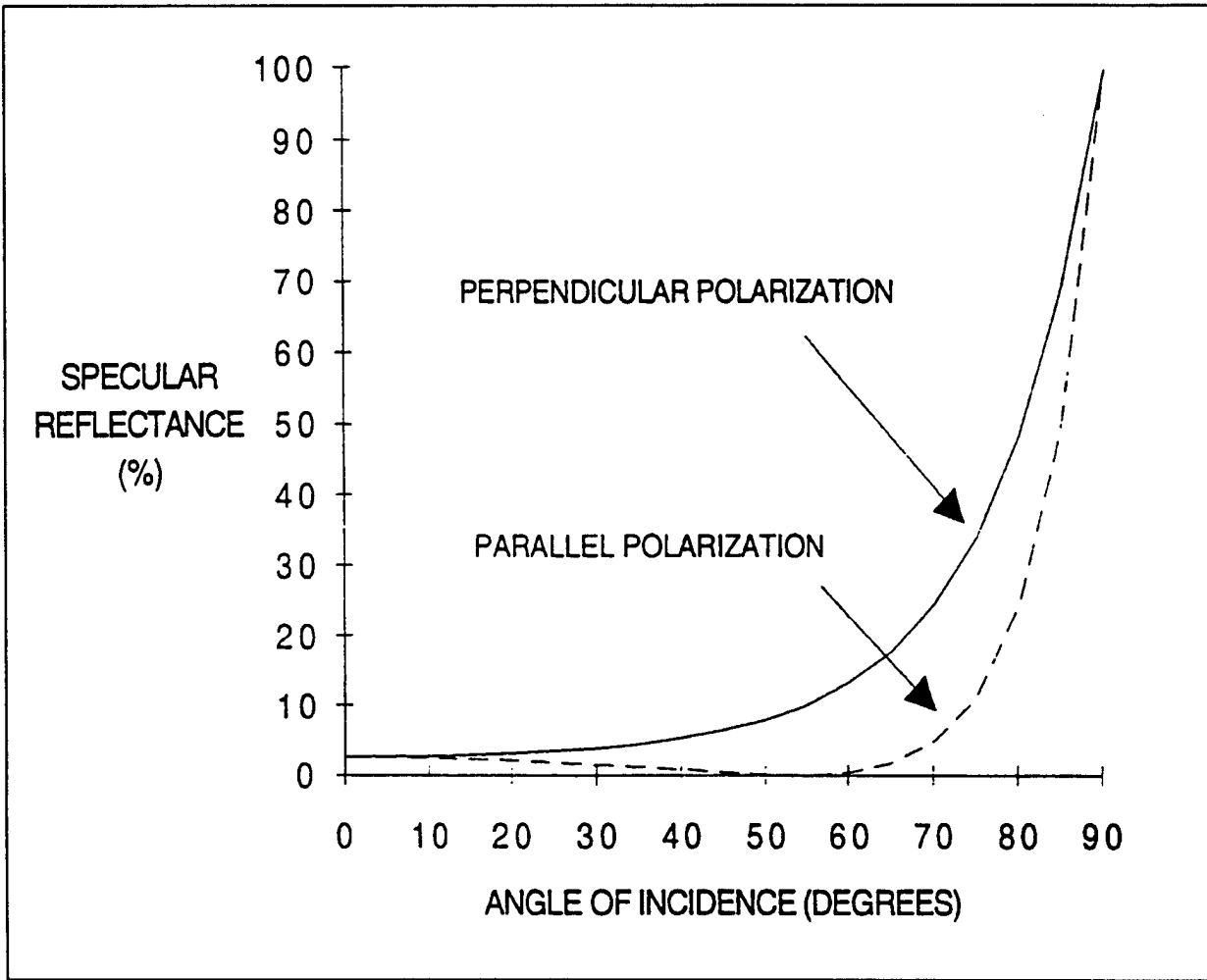

Figure G-4. Specular reflectance from sea water (index of refraction = 1.378).

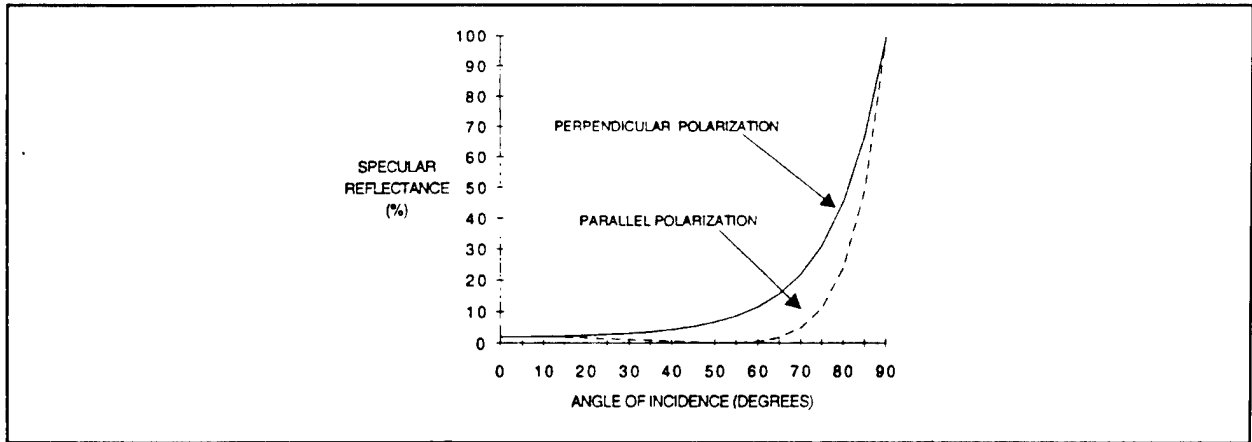

Figure G-5. Specular reflectance from fresh water (index of refraction =1.33).

If the fractions of the laser beam polarizations are not known, choose the highest reflectivity for the given angle of incidence. Typical values are given in Tables G-1 through G-3. Calculate the value of NOHR for various values of D1 and θ . Choose the worst case NOHR to restrict airspace, ships, vehicles or projecting land masses.

3.2.2 Reflection from Reflector Smaller than Incident Laser Beam Cross Section. Reflective objects that are smaller in cross section than the incident laser beam will pose less of a reflection hazard, because only a proportional amount of laser radiation will be reflected. Small reflectors will also cause diffraction effects. For a detailed explanation, see reference in the applicable documents section of this appendix. Ignoring diffraction effects and second surface reflection, the hazard distance from reflectors smaller than the incident laser beam cross section is given by

$$\begin{aligned} \text{NOHR} &= H2/\cos(\theta) = \text{NOHD} \times (\%P \times R_{\parallel} + \%N \times R_{\perp})^{1/2} (RA/LA)^{1/2} - H1/\cos(\theta) \\ &= \text{NOHD} \times [\%P(\tan^2(\theta-\theta'))/(\tan^2(\theta+\theta')) + \%N(\sin^2(\theta-\theta'))/(\sin^2(\theta+\theta'))]^{1/2} \times (RA/LA)^{1/2} \\ &- H1/\cos(\theta) \end{aligned}$$

where

RA = cross sectional area of the reflector

LA = cross sectional area of the incident laser beam

NOHR = Nominal Ocular Hazard Distance from reflector

H1 = altitude of laser

H2 = altitude of observer viewing reflected laser beam

θ = angle incident and reflected laser beam makes with a line perpendicular to the reflecting surface (angle of incidence) = $\arctan(D1/H1)$ for a flat reflector on flat ground.

D1 = horizontal distance from laser to reflector

θ' = angle of refracted beam in a reflecting media = $\arcsin(\theta/n)$

n = index of refraction of reflecting media

%P = fraction of laser beam polarized parallel to plane of incidence

%N = fraction of laser beam polarized perpendicular to plane of incidence

NOHD = Nominal Ocular Hazard Distance (see Table A-1 for typical distances)

$R_{||}$ = Parallel polarization reflection coefficient = $(\tan^2(\theta-\theta'))/(\tan^2\theta+\theta')$

R_{\perp} = Perpendicular polarization reflection coefficient = $(\sin^2(\theta-\theta'))/(\sin^2(\theta+\theta'))$

If the fractions of the laser beam polarization's are not known, choose the highest reflectivity for the given angle of incidence. Typical values are given in Tables G-1 through G-3. Calculate the value of NOHR for various values of D1 and θ . Choose the worst case NOHR to restrict airspace, ships, vehicles, or projecting land masses. Table G-4 gives the reflectivity of shiny metal.

TABLE G-1. REFLECTIVITY OF GLASS AT VARIOUS ANGLES OF INCIDENCE

MATERIAL - GLASS

APPROX. INDEX OF REFRACTION AT WAVELENGTHS 0.3 TO 2 MICRONS = 1.55

ANGLE OF INCIDENCE (DEGREES)	REFLECTIVITY	
	PERPENDICULAR POLARIZATION	PARALLEL POLARIZATION
0	0.0465	0.0465
10	0.0484	0.0447
20	0.0545	0.0391
30	0.0664	0.0299
40	0.0877	0.0175
50	0.1254	0.0046
60	0.1935	0.0012
70	0.3199	0.0400
80	0.5574	0.2334
90	1.0	1.0

TABLE G-2. REFLECTIVITY OF FRESH WATER AT VARIOUS ANGLES OF INCIDENCE

MATERIAL - FRESH WATER

APPROX. INDEX OF REFRACTION AT WAVELENGTHS 0.3 TO 2 MICRONS = 1.33

ANGLE OF INCIDENCE (DEGREES)	REFLECTIVITY	
	PERPENDICULAR POLARIZATION	PARALLEL POLARIZATION
0	0.0201	0.0201
10	0.0210	0.0191
20	0.0241	0.0164
30	0.0305	0.0117
40	0.0426	0.0057
50	0.0660	0.0006
60	0.1139	0.0044
70	0.2180	0.0473
80	0.4552	0.2387
90	1.0	1.0

TABLE G-3. REFLECTIVITY OF SEA WATER AT VARIOUS ANGLES OF INCIDENCE

MATERIAL - SEA WATER

APPROX. INDEX OF REFRACTION AT WAVELENGTHS 0.3 TO 2 MICRONS= 1.378

ANGLE OF INCIDENCE (DEGREES)	REFLECTIVITY	
	PERPENDICULAR POLARIZATION	PARALLEL POLARIZATION
0	0.0253	0.0253
10	0.0264	0.0241
20	0.0302	0.0207
30	0.0378	0.0151
40	0.0521	0.0078
50	0.0790	0.0010
60	0.1324	0.0037
70	0.2433	0.0467
80	0.4826	0.2403
90	1.0	1.0

TABLE G-4. REFLECTIVITY OF SHINY METAL

MATERIAL - SHINY METAL (SILVER) AT ALL ANGLES OF INCIDENCE

WAVELENGTH (Microns)	REFLECTIVITY
0.45	0.88
0.50	0.90
0.55	0.915
0.60	0.927
0.65	0.935
0.70	0.941
0.80	0.951
0.90	0.96
1.0	0.965

APPENDIX H

**SEPARATE TARGET (SEPTAR)
AND SHIP TOWED TARGET OPERATIONS**

APPENDIX H

SEPARATE TARGET (SEPTAR) AND SHIP TOWED TARGET OPERATIONS

1.0 Scope

This appendix provides safety guidance on SEPTAR and ship towed target operations.

2.0 Applicable Documents

US Navy E0410-BA-GYD-010, Technical Manual Laser Safety

NATO STANAG 3606, Evaluation and Control of Laser Hazards

3.0 SEPTAR Operations

SEPTARs may be used for A-6E TRAM, OV-10D NOS, F-111F PAVE TACK, and PAVE SPIKE laser operations in open restricted areas provided

- 2-nautical mile (nmi) SEPTAR operating area is established with a 1-, 2-, 3-, 4-, or 5-nmi buffer zone around the operating area (see Figure H-1) as appropriate for the flight profiles in Tables H-1 through H-5;
- no laser operations within 10 nmi of land are allowed when the laser line of sight (LLOS) is directed toward land;
- all specular reflectors on the SEPTAR must be removed or covered prior to laser operations;
- every person required to be within the operations areas or buffer zone must wear laser protective goggles of adequate protection at 1.06 micron wavelength during laser operations;
- the target must be positively identified on the operator's monitor before lasing;
- laser operations shall cease if either the pilot or system operator is dissatisfied with target tracking;
- lasing shall cease if unprotected or unauthorized aircraft enter the operations area or buffer zone from 0 to 1800 feet above mean sea level (MSL) or between the lasing aircraft and the target;
- lasing shall cease if unprotected or unauthorized surface craft enter the operations area or buffer zone;
- the aircraft must be at or above the flight profiles shown in Tables H-1 through H-5 for the assigned buffer zone; and
- a log of the date and time of all laser firings must be kept.

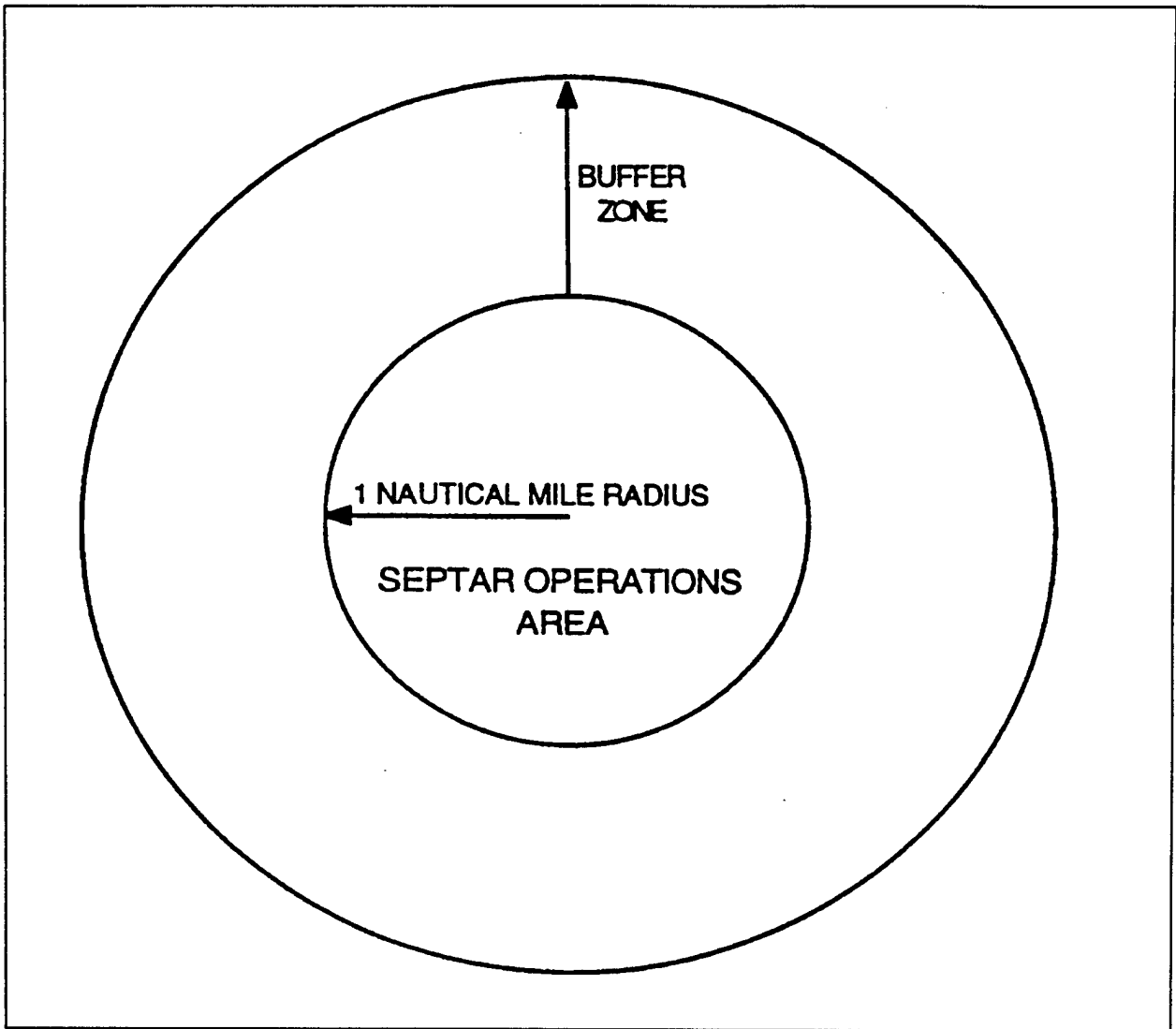
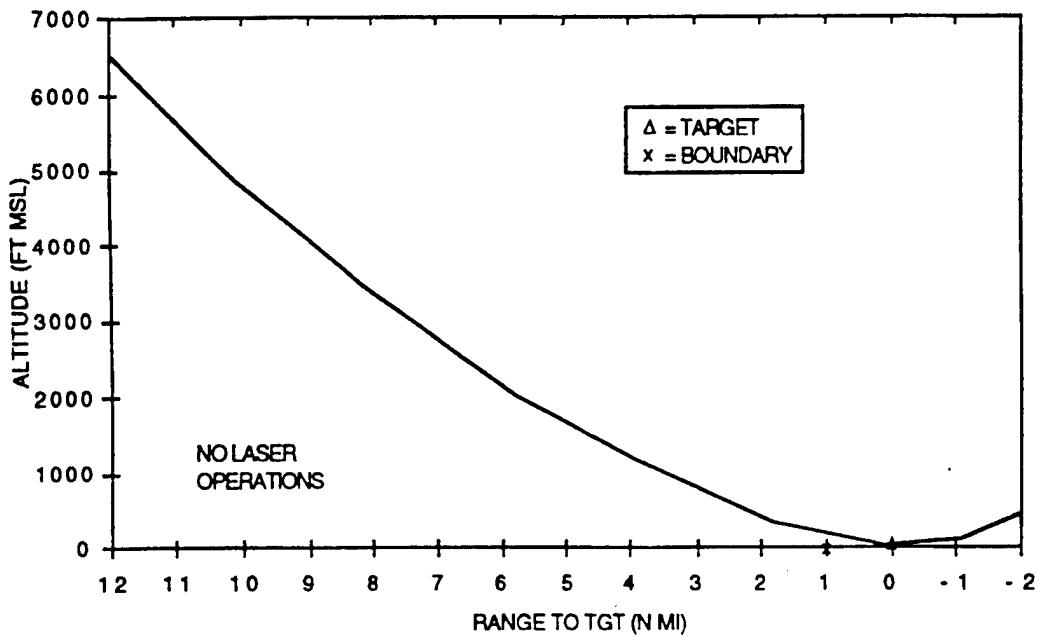

Figure H-1. SEPTAR operations area and buffer zone.

TABLE H-1. FLIGHT PROFILE AGAINST SEPTAR. ONE NMI BUFFER ZONE AROUND 1 NAUTICAL MILE OPERATION AREA - 0 TO 360°



RANGE TO TARGET (N MI)	MINIMUM ALTITUDE (FT)	RANGE TO TARGET (N MI)	MINIMUM ALTITUDE (FT)
12	6550	0	50
11	5650	1	150
10	4850	2	450
9	4050		
8	3350		
7	2750		
6	2150		
5	1650		
4	1250		
3	850		
2	450		
1	250		

TABLE H-2. FLIGHT PROFILE AGAINST SEPTAR. TWO NMI BUFFER ZONE AROUND 1 NAUTICAL MILE OPERATION AREA - 0 TO 360°

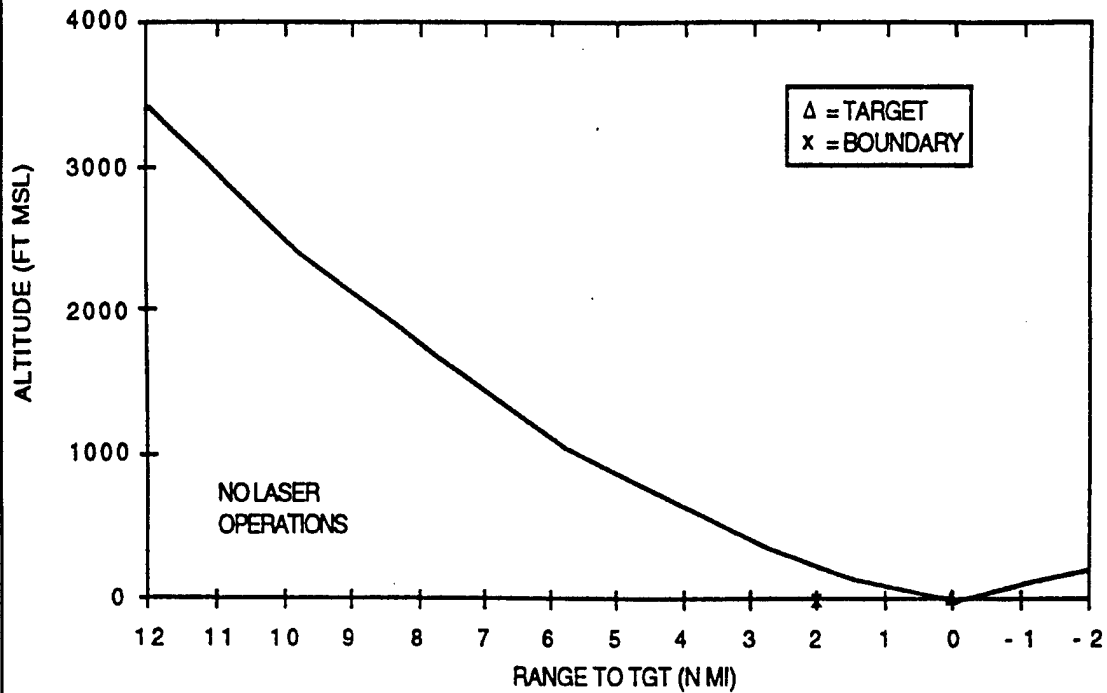

<u>RANGE TO TARGET (N MI)</u>	<u>MINIMUM ALTITUDE (FT)</u>	<u>RANGE TO TARGET (N MI)</u>	<u>MINIMUM ALTITUDE (FT)</u>
12	3450	0	50
11	3050	1	150
10	2550	2	250
9	2150		
8	1850		
7	1450		
6	1150		
5	950		
4	650		
3	450		
2	250		
1	150		

TABLE H-3. FLIGHT PROFILE AGAINST SEPTAR. THREE NMI BUFFER ZONE
AROUND 1 NAUTICAL MILE OPERATION AREA - 0 TO 360°

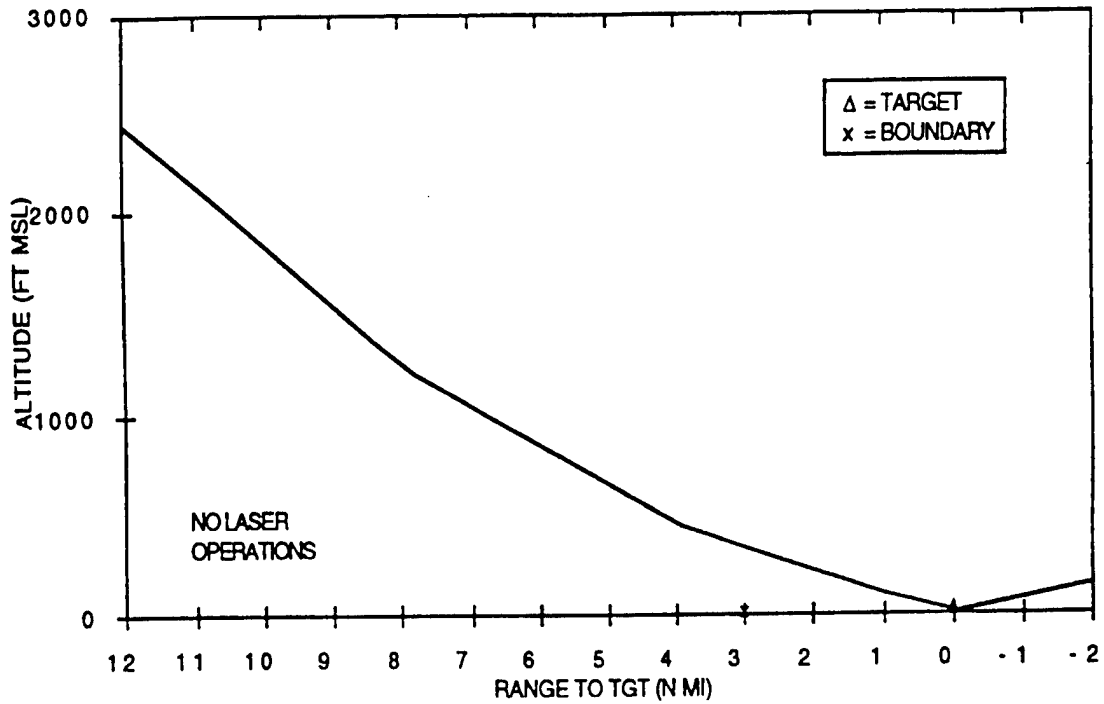

<u>RANGE TO TARGET (N MI)</u>	<u>MINIMUM ALTITUDE (FT)</u>	<u>RANGE TO TARGET (N MI)</u>	<u>MINIMUM ALTITUDE (FT)</u>
12	2450	0	50
11	2150	1	100
10	1850	2	150
9	1550		
8	1250		
7	1050		
6	850		
5	650		
4	450		
3	350		
2	250		
1	100		

TABLE H-4. FLIGHT PROFILE AGAINST SEPTAR. FOUR NMI BUFFER ZONE
AROUND 1 NAUTICAL MILE OPERATION AREA - 0 TO

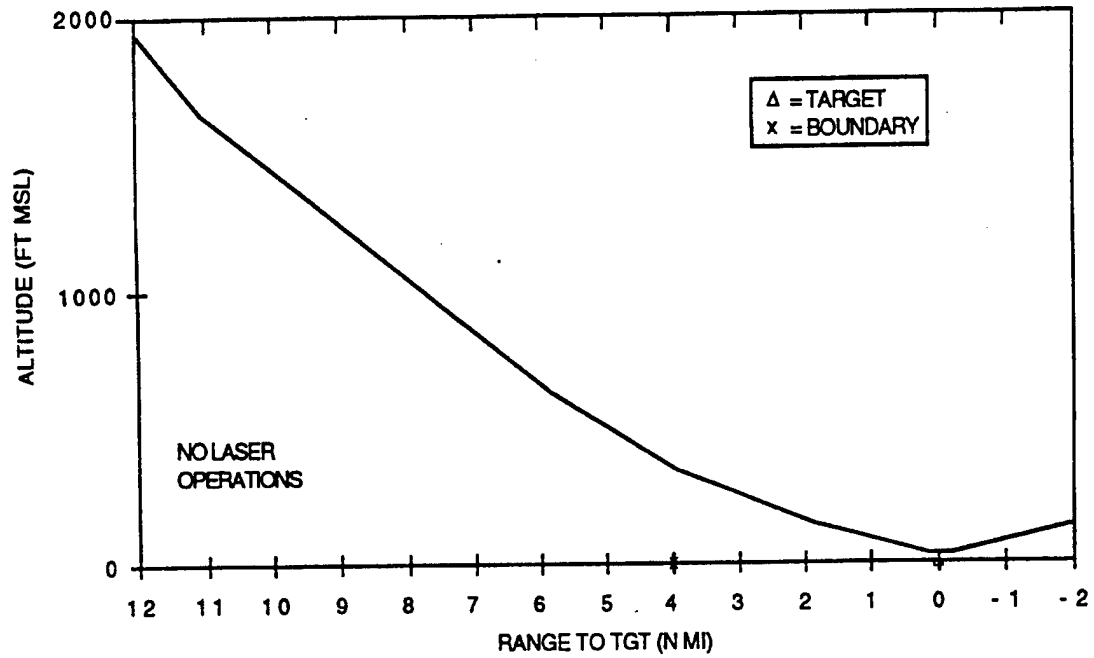

<u>RANGE TO TARGET (N MI)</u>	<u>MINIMUM ALTITUDE (FT)</u>	<u>RANGE TO TARGET (N MI)</u>	<u>MINIMUM ALTITUDE (FT)</u>
12	1950	0	50
11	1650	1	100
10	1450	2	150
9	1250		
8	1050		
7	850		
6	650		
5	550		
4	350		
3	250		
2	150		
1	100		

TABLE H-5. FLIGHT PROFILE AGAINST SEPTAR. FIVE NMI BUFFER ZONE AROUND 1 NAUTICAL MILE OPERATION AREA - 0 TO 360°

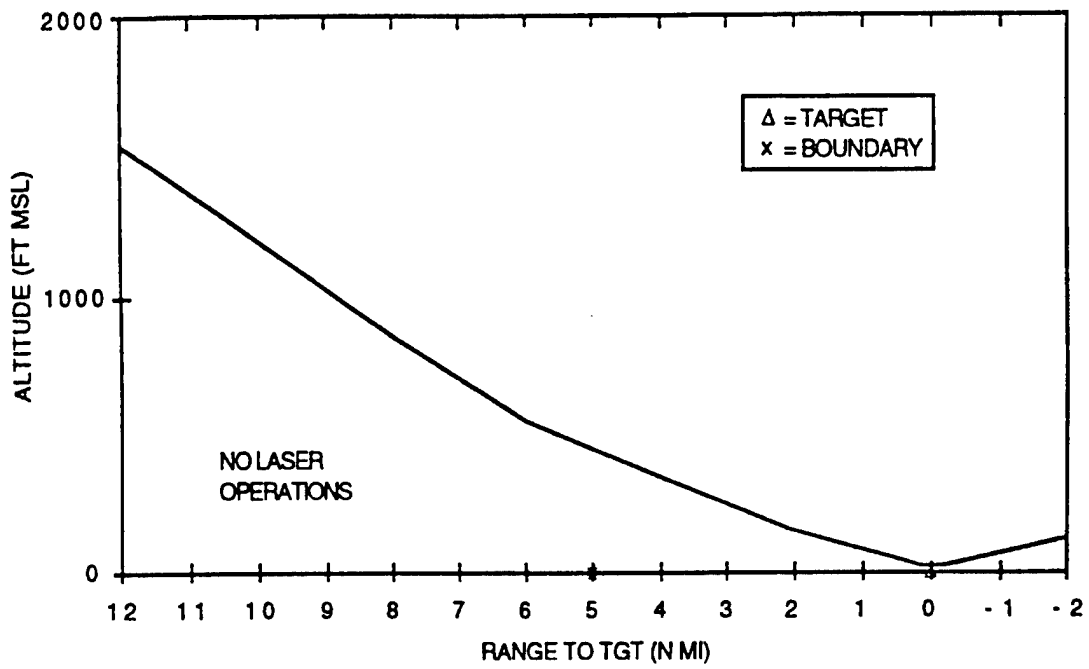

<u>RANGETO TARGET (N MI)</u>	<u>MINIMUM ALTITUDE (FT)</u>	<u>RANGETO TARGET (N MI)</u>	<u>MINIMUM ALTITUDE (FT)</u>
12	1550	0	50
11	1350	1	100
10	1250	2	150
9	1050		
8	850		
7	750		
6	550		
5	450		
4	350		
3	250		
2	150		
1	100		

4.0 Ship Towed Target Operations

Ship's towed target operations as shown in Figure H-2 shall abide by the following:

- 4.1 The target shall be towed no closer than 1000 feet from the towing ship.
- 4.2 All laser operations shall be conducted on incoming headings of 60 to 90° and 260 to 300° relative to towing ship's heading. If lasing back at the target is required, after passing over it, the outgoing heading shall be in the zones specified above for the incoming headings (see Figure H-2).
- 4.3 Laser operation shall not be initiated until the laser operator has identified the target under the reticle on the display, and the pilot has identified the target through the optical gun sight.
- 4.4 Laser operation must cease if the system is not properly tracking the target.
- 4.5 Laser operation shall cease immediately after weapon release for conventional ordnance or immediately after weapon impact for laser-guided ordnance.
- 4.6 Laser operation shall cease whenever friendly ships are within 48,000 feet of the target along the LLOS and ± 700 feet either side of the LLOS, unless the use of laser protective eyewear by onboard personnel is assured.
- 4.7 Laser operations shall cease whenever friendly aircraft operating below 6,000 feet altitude are within 31,000 feet of the target along the LLOS and ± 700 feet either side of the LLOS, unless the use of laser protective eyewear by onboard personnel is assured.
- 4.8 Optical aids used to view the target during laser operations must be equipped with proper protective filters when the viewer is within the boundaries cited and along the LLOS out to the optical aids nominal ocular hazard distance for the specific laser and specific optical aid.
- 4.9 Viewing of the target with optical aids from the towing ship or from other ships and aircraft outside of the laser beam hazard control zone described above is permitted.
- 4.10 Targets shall be non-specular.
- 4.11 A log of the date, time, and heading of all laser firings must be kept.

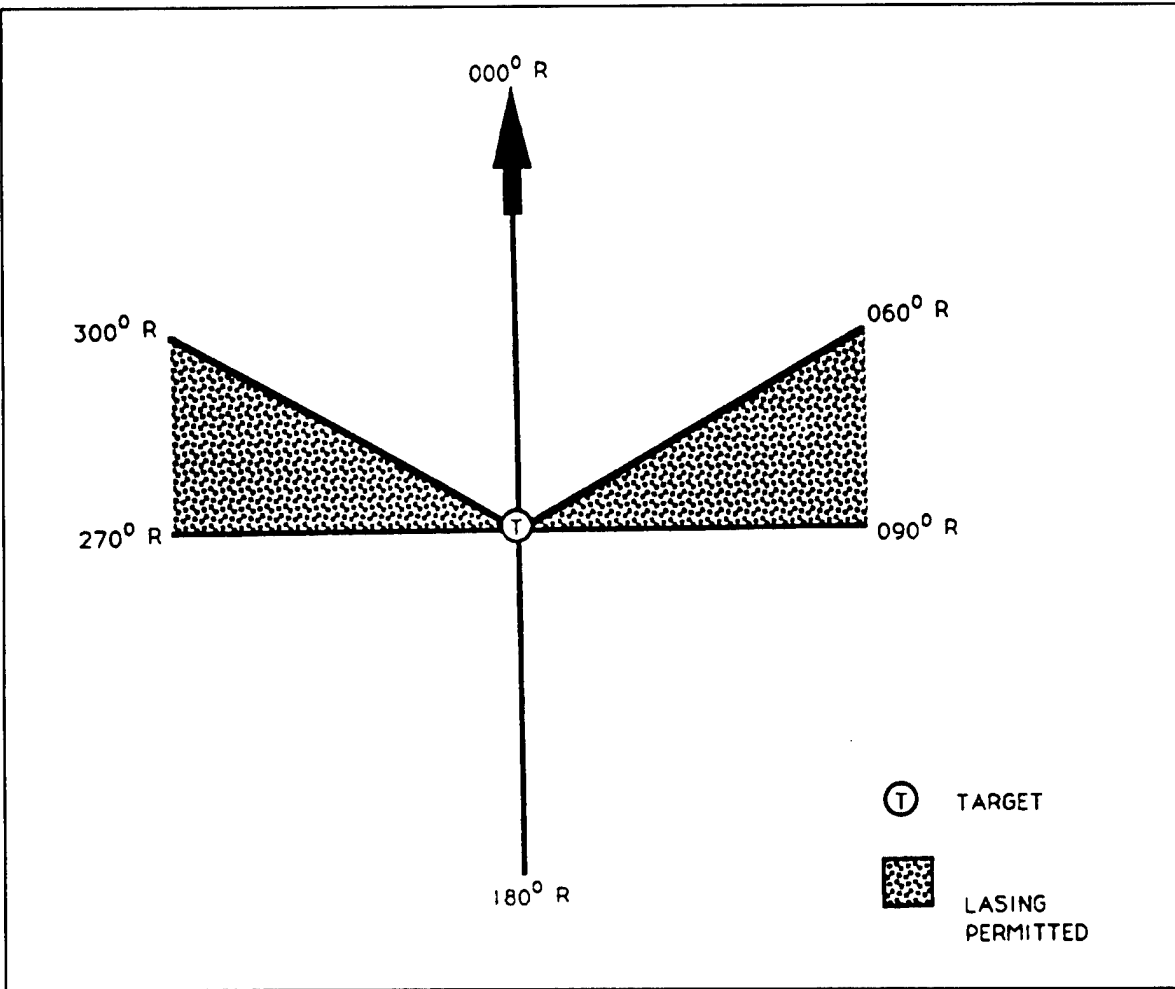

Figure H-2. Zones relative to towing ship's heading in which laser operations are permitted for A-6E TRAM, OV-10D NOS, F111-PAVE TACK, and PAVE SPIKE.

APPENDIX I

**SATELLITE SAFETY PROCEDURES
FOR SPACE DIRECTED LASERS**

APPENDIX I

SATELLITE SAFETY PROCEDURES FOR SPACE DIRECTED LASERS

1.0 Scope

These guidelines establish the Space Control Center (SCC) Laser Clearinghouse (LCH) procedures.

2.0 References

USCINCSpace OPLAN 3400.90 page iii (classified secret)

Joint Strategic Capability Plan, paragraph g(2) (a)7. USCINCSpace will "Disseminate information relating to and provide measures for protecting vital US and allied space systems from interference by collision, directed energy, anti-satellite, nuclear detonation, sabotage, or electronic warfare."

Derivation and Use of the SPADOC Laser Clearinghouse Threshold Curve, June 1983, SAIC. (classified secret)

3.0 Definitions for Space-Directed Laser Emissions

Accidental Illumination - Laser illumination of a satellite payload which was not the intended target, and/or the operation of a laser outside of LCH/PA windows provided by the SCC.

Beam Divergence Half Angle - A parameter which describes the angular spread of a laser beam measured from the beam's center out to the point where intensity falls to 37 percent of its original value. Typically measured in radians.

Damage - Any physical impairment, either temporary or permanent, of the normal operating capability of a satellite.

DOD Components - A term meaning collectively the Office of the Secretary of Defense, the Joint Chiefs of Staff, the Unified and Specified Commands, the Military Departments, and the Defense Agencies (including national laboratories).

Jitter Angle - The factor which accounts for the mechanical pointing inaccuracies of the laser. The angle, from beam center, in which the beam is located with 96.6 percent probability (2 sigma).

Laser Clearinghouse - A function within USCINCSpace/SCC which maintains the laser facility data base, receives laser facility emission requests determines waiver status, sends approval/denial/restrictions to the laser facilities, and processes accidental illumination information.

Laser Damage Threshold - A predetermined level of laser intensity designed to protect satellite sensor material from damage.

Laser Facility - The laser device, supporting system and equipment, tracking mechanism, personnel, building and platform.

Output Aperture Diameter - The beam diameter at the emitter aperture (meters).

Predictive Avoidance Windows - Time intervals generated by SCC allowing a laser to safely conduct space-directed operations without fear of accidentally illuminating satellites.

Payload - The portion of a satellite that contains instrumentation and recording devices, transmitters and receivers, and related support equipment.

Radiant Intensity - The strength of a laser emission at the facility in units of power per solid angle, usually in watts per steradian.

Relative Intensity (IREL) - Accounts for thermal blooming. This factor is defined as the ratio of the actual (experimental) intensity compared to that obtained by a perfect beam (theoretical).

Satellite - Any man-made object in earth orbit.

Satellite Owner/Operator - The agency, unit, company, or other organization responsible for the operation of an orbiting satellite and its command, control, communication, and data utilization.

SCC - Space Control Center (formerly SPADOC) located inside Cheyenne Mountain in Colorado Springs, Colorado.

Strehl Beam Quality Factor - Measures the imperfections within the laser. The factor is equal to the square root of the theoretical power divided by the observed power at a given point.

Target - The satellite which is the intended object of laser illumination.

USCINCSpace - Commander-in-Chief United States Space Command.

USSPACECOM - United States Space Command.

Waiver - Written permission from JCCDOA granting a laser facility permission to freely operate a space directed laser without the need for safe firing windows

4.0 Applicability

4.1 The Commander in Chief, United States Space Command (USCINCSpace) is the executive agent for Laser Clearinghouse and, acting through the SCC, is directed by the Joint Strategic Capability Plan to authorize the emission of laser radiation from all DOD or DOD sponsored lasers that have the potential of interfering with, degrading, or damaging any United States or foreign satellite.

4.2 These guidelines apply to all space directed DOD laser facilities, either land based, sea based, airborne, or space based; mobile or fixed including those owned, operated, or controlled by DOD components or by agencies or contractors under the auspices of DOD components. (NOTE: U. S. SPACECOM Laser Clearinghouse is only concerned with lasers which are intentionally directed towards space, that is, lasers used for atmospheric research, satellite analysis, astronomical research, and Ballistic Missile Defense testing.). These guidelines apply to United States non-DOD satellite owner/operators (O/Os) by agreement with the SCC. These guidelines do not apply to allied or foreign satellite O/Os. (If there is an interest in lasing a non-United States satellite, contact the SCC for special procedures.)

4.3 These guidelines specify the responsibilities and procedures for

- evaluating a laser's damage potential,
- scheduling emissions of laser energy from DOD sources into space to avoid interference or damage to United States or foreign satellite payloads, and
- responding to accidental laser illumination events.

5.0 Concept of Operations

5.1 The USCINCSpace is tasked by the Joint Chiefs of Staff, the Joint Strategic Capability Plan, to provide the capability and to act as the focal point to authorize laser emissions into space by DOD components which may result in interference or damage to United States or foreign satellite payloads. This task is performed under the direct operational control of the SCC Space Control Director (SCD) located inside Cheyenne Mountain Air Station (CMAS), Colorado Springs, Colorado. The SCC SCD, based on authority delegated by USCINCSpace, is the focal point for space control operations which includes the Laser Clearinghouse program.

5.2 The Combat Analysis Section (JCCDOA) will maintain a database of all known DOD laser facilities. Each DOD laser facility will initially notify JCCDOA of its lasers parameters. The JCCDOA will determine the laser's damage potential and either grant a blanket waiver for the laser or coordinate to determine safe laser firing times.

5.3 Facilities operating a non-waived laser will request permission from SCC to emit space directed laser energy. The SCC in turn will provide the facility with Predictive Avoidance (PA) safe firing windows. The PA windows provide the laser facility with safe laser start/stop times ensuring no satellite payloads will be unintentionally illuminated. The SCC will monitor changes in space activity and may update issued PA windows. The SCC may request data from DOD lasers in support of accidental illumination analysis. The SCC will notify the National Military Command Center (NMCC) or alternate agencies and DOD satellite O/Os, as appropriate, of accidental laser illumination. Laser facilities will monitor their operations and report any anomalies to the SCC which could have led to an accidental illumination.

6.0 JCCDOA Responsibilities

6.1 Send each laser facility a LCH introductory package upon initial contact.

6.2 Upon receipt of the LCH Information Sheet (see Attachment 1), determine if a laser has the potential of damaging or interfering with satellite payloads. Interference and damage potential is determined using SCC's laser threshold data. The laser facility will be notified of the results by use of a LCH Waiver Response letter (see Attachment 2). The JCCDOA shall reevaluate a laser's waiver status upon notification from a laser facility of a laser parameter change or when laser threshold data change. The JCCDOA shall provide initial guidance to laser facilities on proper message formats.

6.3 Develop, maintain, and operate new LCH software as required. Maintain SCC's threshold comparison procedures as new sensor technology is developed and more refined analysis techniques are employed. All waivers issued to lasers will be reevaluated whenever the waiver procedures or thresholds are modified.

6.4 Maintain a current database of all DOD laser facilities.

6.5 Receive and respond to LCH PA requests by providing PA safe firing windows using the LCH PA windows message (AUTODIN traffic is preferred, and all message formats are described in SPADOC ICD 2025 and 3225).

6.6 The SCC will compute and transmit the LCH safe firing windows to the requesting site not later than 4 hours before the site firing begins.

6.7 After generating PA safe firing windows, the SCC will keep a watch for space events that could alter previously issued windows. If such an event occurs, the SCC will ask the laser operator to suspend laser firing using established communications. The SCC will recalculate the PA safe firing windows and send the new windows to the laser site. When the new windows are received, the laser site may continue operations.

6.8 If an Accidental Illumination Report is received, or if an accidental illumination is suspected, the SCC will analyze the event to determine, as accurately as possible, the illumination source and vulnerable targets.

6.8.1 Upon notification or suspicion of an accidental illumination, the SCC will

- find all satellite payloads visible to the laser (within a cone about the beam),
- contact the O/Os of those satellite systems identified as vulnerable and request information pertaining to system anomalies, and
- send an LCH Accidental Illumination Report to the involved satellite O/Os and laser site operators within 24 hours, if necessary.

6.8.2 Upon sufficient cause to suspect an accidental illumination event, the SCC will

- review PA window requests to identify active lasers,
- determine which laser sites were visible to the affected satellites during the period of interest,
- send a LCH Activity Request to suspected laser sites within 1 hour, and the laser sites should respond within 24 hours with a LCH Activity Report, and
- analyze all information and if necessary, send a LCH Accidental Illumination Report to the NMCC or alternates within 8 hours and to the involved satellite O/Os and laser site operators within 8 hours.

7.0 Laser Facility Responsibilities

7.1 Send a LCH Information Sheet to JCCDOA for every new laser facility or for every new laser at a facility approximately 30 days prior to the first intended space directed emissions. The JCCDOA will respond to the waiver request with a LCH Waiver Response. If the JCCDOA determines the laser at the facility is powerful enough to interfere with or damage satellite payloads, the site must request LCH PA safe firing windows from the SCC.

7.2 Notify the JCCDOA whenever a laser's parameters are changed using the LCH Information Sheet. The JCCDOA will reevaluate and update the waiver status.

7.3 If required, request LCH PA safe firing windows from SCC using the LCH PA Request message no later than 48 hours prior to the start of actually firing the laser.

7.4 Notify the SCC as soon as possible whenever planned laser testing is postponed or canceled.

7.5 Obtain permission to use a satellite as a target from a satellite O/O if a satellite payload is the intended target.

7.6 Submit within 1 hour of detection a LCH Accidental Firing message to SCC if the facility believes it illuminated the wrong satellite or operated outside of safe firing windows supplied by the SCC.

7.7 Respond within 24 hours of receipt of a LCH Activity Request with a LCH Activity Report. With this report, identify space directed laser emissions for lasers, regardless of waiver status.

7.8 When operations are classified, communications with the SCC will be via the communication channels necessary for the classification level.

LASER CLEARINGHOUSE INFORMATION SHEET

Orbital Safety Officer - CMOC/JCCDOA

FAX: (719) 474-2131 Voice: DSN 268-4496 or Commercial (719) 474-4496

Laser Site:

Section 1: Point of Contact

Name:

Mailing Address:

Commercial Phones:

DSN Phones:

Secure Phones & Type:

FAX:

AUTODIN Routing Indicator and Plain Language Address:

Section 2: Project Data

Project Name:

Project Start Date:

Project Completion Date:

Typical Laser Target (check all that apply)

Look-Angle Missile Star Satellite

For missile targets contact LCH.

Section 3: Site Geodesics

Fixed Site:

Lat _____ deg

Long _____ deg

Alt _____ kin

Section 4: Laser Parameters

CONTINUOUS WAVE LASERS

Firing Mode	Prime
1 2 3	

Output Power
(Watts)

Wavelength
(Meters)

Divergence
Half-Angle
(Radians)

Operating
Time (Seconds)

*Output Aperture

Diameter (Meters)

*Jitter Angle (Degrees)

*Strehl Beam Quality (Percent)

*Relative Intensity (Percent)

* To be used by our on-line software, please provide this information if known. Other parameters are required for waiver analysis.

PULSED LASERS

Firing Mode	Prime
1	2
	3

Pulse Width
(Seconds)

Pulse Repetition
Frequency (Hertz)

Pulse Energy
(Joules)

Divergence
Half-Angle
(Radians)

Wavelength
(Meters)

Operating

Time (Seconds)

*Output Aperture
Diameter (Meters)

*Output Power at
Output Aperture (Watts)

*Jitters Angle (Degrees)

*Strehl Beam Quality (Percent)

*Relative Intensity (Percent)

* To be used by our on-line software, please provide this information if known. Other parameters are required for waiver analysis.

UNITED STATES SPACE COMMAND SAMPLE WAIVER RESPONSE

FROM: CMOC/JCCDOA
Suite 9-101A
1 NORAD Rd.
Cheyenne Mountain AFS, CO 80914-6020

SUBJ: SPADOC Laser Clearinghouse Waiver Response

TO: Laser Site

1. I have evaluated the laser from your fax of 29 DEC. The laser described below is not waived and will require predictive avoidance screening. Please contact me at least 48 hours prior to any lasing so we can compute your open window times.

Type: Pulsed

Wavelength:	XXX Meters
Pulse Energy:	XXX Joules
Divergence:	XXX Radians (half-angle)
Pulse Rep. Freq.	XXX Hertz
Pulse Width:	XXX Seconds

2. Let me know if I can be of further assistance. I can be reached at U.S. Space Command (DSN 268-4496, (719)474-4496).

Orbital Safety Officer