

R  
129084

JPRS-UEN-84-009

3 April 1984

# USSR Report

ENERGY

19981023 120

DTIC QUALITY INSPECTED 2

**FBIS** FOREIGN BROADCAST INFORMATION SERVICE

9  
90  
A05

#### NOTE

JPRS publications contain information primarily from foreign newspapers, periodicals and books, but also from news agency transmissions and broadcasts. Materials from foreign-language sources are translated; those from English-language sources are transcribed or reprinted, with the original phrasing and other characteristics retained.

Headlines, editorial reports, and material enclosed in brackets [] are supplied by JPRS. Processing indicators such as [Text] or [Excerpt] in the first line of each item, or following the last line of a brief, indicate how the original information was processed. Where no processing indicator is given, the information was summarized or extracted.

Unfamiliar names rendered phonetically or transliterated are enclosed in parentheses. Words or names preceded by a question mark and enclosed in parentheses were not clear in the original but have been supplied as appropriate in context. Other unattributed parenthetical notes within the body of an item originate with the source. Times within items are as given by source.

The contents of this publication in no way represent the policies, views or attitudes of the U.S. Government.

#### PROCUREMENT OF PUBLICATIONS

JPRS publications may be ordered from the National Technical Information Service (NTIS), Springfield, Virginia 22161. In ordering, it is recommended that the JPRS number, title, date and author, if applicable, of publication be cited.

Current JPRS publications are announced in Government Reports Announcements issued semimonthly by the NTIS, and are listed in the Monthly Catalog of U.S. Government Publications issued by the Superintendent of Documents, U.S. Government Printing Office, Washington, D.C. 20402.

Correspondence pertaining to matters other than procurement may be addressed to Joint Publications Research Service, 1000 North Glebe Road, Arlington, Virginia 22201.

Soviet books and journal articles displaying a copyright notice are reproduced and sold by NTIS with permission of the copyright agency of the Soviet Union. Permission for further reproduction must be obtained from copyright owner.

3 April 1984

USSR REPORT  
ENERGY

CONTENTS

FUELS

OIL AND GAS

Al'met'yevneft' NGDU Evaluates Well Preparation, Benefits of Competition  
(F. X. Davletshin, D. Gazizov; NEFTYANOE KHOZYAYSTVO, No 1, Jan 84) ..... 1

Briefs

Kuybyshevneft' Above Plan Oil Production	6
Drilling on the Zhdanov Shore	6
Sakhalin Shelf Oil Explorations	6
New Prospecting Concept	6
Gorskneft' Recovery Quotas Outstripped	7
Gas-Lift Speeds Oil Recovery	7
West Kazakhstan's Oil Production	7
Caspian Oil Workers Get Ships	8
Oil From Caspian's Depths	8

COAL

Synopses of Articles in UGOL' UKRAINY , December 1983 (UGOL' UKRAINY, No 12, Dec 83) .....	9
---	---

ALTERNATE FUELS

Mining Encyclopedia To Be Published (TORFYANAYA PROMYSHLENNOST', No 12, Dec 83) .....	15
Synopses of Articles in TORFYANAYA PROMYSHLENNOST' , December 1983 (TORFYANAYA PROMYSHLENNOST', No 12, Dec 83) .....	17

## ELECTRIC POWER

### NUCLEAR POWER

Delivery Problems, Equipment Shortages at AES Construction Sites (MATERIAL'NO-TEKHICHESKOYE SNABZHENIYE, No 9, Sep 83) ....	20
Construction Schedules Not Met, by A. Gusev Responses to Editors Admit Errors	
Planned Development of New Sheet Rolling Mill at Izhorsk Plant (N. Andreyeva; STROITEL'NAYA GAZETA, 29 Jan 84) .....	25
<b>Briefs</b>	
Kursk AES Construction	27
Smolensk AES Construction	27
Increased AES Equipment Production	27
Ignalina AES Start-Up	27
Zaporozh'ye AES VKU Equipment	28

### NON-NUCLEAR POWER

Hydroelectric Power Promoted in Lithuania (Yuozas Burneykis; SOBYTIYA I VREMYA, No 19, Oct 83) .....	29
Moscow Replacing High Power Overhead Lines With Underground Electric Cables (B. Aleksandrov; IZVESTIYA, 9 Nov 83) .....	34
First Direct-Current Power Transmission Line Under Construction in Kirghizia (B. Plotnikov; SOVETSKAYA KIRGIZIYA, 21 Dec 83) .....	36
<b>Briefs</b>	
Osetia-Georgia Power Linkage	38
Power Lines Near Chara	38
Ekibastuz-Urals Line Operational	38
Energy Bridge Operational	39
Beskaragayskiy Rayon Gets Power	39
Georgia, North Caucasus Electricity Link	39
Angara-Boguchan Lep Operational	39

## PIPELINES

### PIPELINE CONSTRUCTION

Techniques for Speeding Pipeline Construction Described (A. G. Mazel'; STROITEL'STVO TRUBOPROVODOV, No 11, Nov 83)	40
---	----

Factors in Choosing Machinery for High-Speed Pipelaying Units Analyzed (A. V. Karasev; STROITEL'STVO TRUBOPROVODOV, No 11, Nov 83)	45
Ways To Improve Output of Large Box Modules for Oil, Gas Industries Described (V. G. Andriyenko; STROITEL'STVO TRUBOPROVODOV, No 11, Nov 83)	49
Erector of Pipeline Compressor, Pump Stations Complains About Poor Support (Ye. S. Kvasha; STROITEL'STVO TRUBOPROVODOV, No 11, Nov 83)	56
Ways of Year-Round Pipeline Building in Swampy Areas Explained (N. P. Vasil'yev; STROITEL'STVO TRUBOPROVODOV, No 11, Nov 83)	59

RELATED EQUIPMENT

Prefabricated Block-Unity Rooms From Almet'yevsk (V. A. Kulik; STROITEL'STVO TRUBOPROVODOV, No 11, Nov 83)	64
---	----

ENERGY CONSERVATION

Kazakh Coal Industry Needs Increased Efficiency, Clear Regulations (E. Krivobokov; KAZAKHSTANSKAYA PRAVDA, 15 Nov 83)	67
Methane Used To Heat Mining Complexes at Dovetskugol' (V. Novoselov; PRAVDA UKRAINY, 16 Nov 83)	71
Measures for Eliminating Fuel Loss at Transportation, Fuel Depots (VYSHKA, 7 Dec 83)	73
Mosenergo Experience in Improving Fuel and Energy Conservation (I. Yershov, Ye. Kuznetsov; PLANOVOYE KHOZYAYSTVO, No 12, Dec 83)	78

OIL AND GAS

AL'MET'YEVNEFT' NGDU EVALUATES WELL PREPARATION, BENEFITS OF COMPETITION

Moscow NEFTYANOE KHOZYAYSTVO in Russian No 1, Jan 84 pp 3-5

[Article by F.X. Davletshin, D. Gazizov, Al'met'yevneft' NGDU [Oil and Gas Extraction Administration]: "Bringing New Wells on Stream Ahead of Time"]

[Text] More than thirty years have passed since the beginning of operations of the Al'met'yevneft' NGDU oil production facilities. At present the percentage of total remaining reserves classified as difficult to recover is more than 2.2 times as high as it was in the initial period, and the water level in extracted fluids has reached 78.8 percent. Consequently, the assurance of the planned high level of oil extraction requires the implementation of a large group of geological and technical measures directed at improving the system of tract and deposit development so as to increase the oil recovery capacity of formations, increase the effectiveness of utilization of the stock of oil and injection wells, labor productivity and achieve the maximal utilization of internal resources.

In 1983, the oil field workers of this administration extracted more than 9.7 million tons of oil, announcing on 30 June the fulfillment ahead of schedule of their annual socialist obligations, having extracted an additional 24,000 tons. By way of implementing the resolutions of the June 1983 CPSU Central Committee Plenum, they committed themselves to producing, by the end of 1983, an additional 16,000 tons of oil in excess of the plan, and fulfilled this obligation with honor.

The positive results of the work of NGDU have been due in large part to the motivation of every member of the collective to achieve the end results of their common labor, and to a display of creative initiative in the discovery and utilization of additional reserves in all aspects of production.

One of the initiatives which has proved to have a large influence on increasing the volume of extracted oil is the innovative program "Bringing New Wells on Stream Ahead of Time," which was conceived back in 1976 at Oil Field No 1. The initiators of this competition--oil and gas recovery foremen Kh.G. Shamsullin and K.E. Zaburdayev, and oil and gas recovery operators A.Sh. Safiullin, hero of socialist labor, M.S. Akhmetov and A.M. Safin

estimated that every newly drilled well stands idle for an average of 68 days, waiting for completion and adaptation for artificial-lift recovery. If this well down time could be shortened by one day, than given an average rate of 165 new wells per year, each with a 25 ton per day extraction capacity, the NGDU would realize an additional 4,125 tons of oil annually. To shorten the time needed to make wells operational, the oilfield workers suggested organizing a socialist competition among the structural subdivisions of the administration which participate in the construction of new wells and their adaptation for artificial-lift extraction.

With this objective in mind, Oil Field No. 1 has signed contracts for work collaboration with SMU [Construction and Installation Administration], TsPRS [not further identified], PRTsEO No. 1 and No. 2 [not further identified], PRTsE and E [not further identified], and TsNIPR [Central Scientific Research Institute of Industrial Operations]. In addition, similar contracts have been signed with functional divisions of NGDU-TsITS [not further identified], as well as production and outfitting departments and others which might participate in the given assignment.

The organization of such a labor competition has had perceptible results in its first year: the time period for making new wells operational at the oil field was shortened from 68 to 26 days which made it possible to recover an additional 20,311 tons of oil.

Once the experiences of the initiators of this new program were studied and generalized, they were recommended for broad application in all recovery divisions, and the initiators of the program signed a contract for labor cooperation with subdivisions of UBR [Drilling Operations Administration].

Participants in the competition have assumed specific obligations for shortening the period needed for well construction and operational startup, while on many occasions combining distinct types of work. This means that at the same time crews from the SMU, PRTsE and E, PRTsEO and TsNIPR may be working on a given well, making it possible to complete many tasks prior to the completion of drilling.

Because of the deep motivation and creative activity of every participant in this competition, the period for putting wells into production has been shortening every year (in 1978 the period was 36.7 days, in 1980 30 days). This collective achieved its greatest success in 1981, when it shortened the period for putting a well into production by a factor of 2 in comparison with 1980.

The signing of a labor cooperation contracts between NGDU and TatNIPIneft' [Scientific Research and Planning Institute for Petroleum of the Tatar USSR], UBR, Tatspetsstroy Construction and Assembly Trust, the PNP [not further identified] and KRS [not further identified] Administration was of great importance in the achievement of the above success. Through these, NGDU came to exercise overall leadership in the bringing of new wells into production.

Major changes in the conditions of the competition between subcontracting organizations was introduced in 1982, when the question was raised at one of the sessions of the correctness of evaluating results by taking into account only the final outcome, i.e. the shortening of the time needed to bring a well into production. Since the conditions of the construction and startup of wells using artificial-lift recovery techniques differs from field to field, it was decided to establish standard periods for the conduct of different types of work. To do this existing standards were used, and where these did not exist, local ones were confirmed. (see Supplement No. 1).

Supplement No. 1. Conditions of Socialist Competition Between Divisions and Subcontracting Organizations

Standard Time Periods for Fulfillment of Tasks by Divisions and Subcontracting Organizations Related to the Construction, Completion, Equipment Installation and Bringing into Production of Wells Using Artificial Lift Techniques for 1983

Indicators	Period for Task Completion	
	<u>Brigade Hours</u>	<u>Brigade Days</u>
Construction-Assembly Administration		
Construction of 1,000 m of oil pipeline	83.9	10.5
Wellhead connections with 50 m of oil pipeline	18.0	2.0
Assembly of equipment platform	4.8	0.6
SK [Stabilizing circuit] assembly, including laying of cable and grounding	25.6	3.2
Construction of 1,000 m of power line with transitions	48.0	6.0
Assembly of KTP [Technical Control Paints] with 50 m of power line	37.5	4.7
Time periods for construction work increase (by 20 percent in winter)		
Rental-Repair Shop for Production Equipment		
Production of PNP [not further identified]	22.8	2.9
Production startup after PRS [not further identified]	8.32	1.0



Hookup of well to oil pipeline	5.75	0.7
Time periods for these tasks increase (by 20 percent in winter)		
Rental-Repair Shop for Electrical Equipment and Supplies		
TP [Transformer Unit] hookup. Startup of electrical equipment after penetration	24	3
(Scientific Research and Production Tasks Shop)		
Well exploration. Selection of equipment. Establishing productivity coefficient	16	2
Well servicing and overhaul shop		
Conduct of operations to implement		
ETsN [Electro-centrifugal pumps]	58.7	2.4
SKN	52.1	2.2
Oil and Gas Recovery Division		
Operational startup and shift of wells to artificial lift recovery	108	16
Rental-Repair Shop for Downhole Pumping Equipment		
providing necessary equipment	as needed	as needed

In addition, the competition was organized into two groups: oilfields comprised the first group, while the shops carrying out specific tasks made up group two.

The transfer of a well among participating organizations after its operational startup is formulated by contract. The job sequence is defined by the production department in consultation with the shops. If a participating organization does work prior to the acceptance of a well as defined by the contract, then this time is not included in the period of its work.

The winner is the collective of the shop which achieves the greatest shortening of the period for bringing a well into production in comparison with the standard.

A lot of attention is paid to publicizing the competition. There are billboards at the oilfields which keep track of the competition between the shops and subcontracting organizations, and which also reflect the progress being made in well construction.

A competition for the bringing into production of new wells has been organized among crews of the SMU, PRTsE and E, PRTsEO, PRS brigades and TsNIPR crews. The progress of the competition between these collectives is also recorded on shop competition billboards. The results of the competition are compiled once each quarter.

A report concerning the work for the quarter, signed by all participants in the competition, is presented at the administration profkom [union committee] by the fifteenth day of the month following the last month of a quarter so that the winner of the competition may be determined. An analysis of the work results for the first three quarters of 1983 showed that an absolute majority of the collectives are completing their tasks within standard time limits. The best results in group 1 were achieved by TsDNG [not further identified] oil fields No. 1, No. 4 and No. 5, which completed their tasks in 60-80 percent of the standard time, while the best performances in group 2 were turned in by TsNIPR, TsPRS and PRTsEO No. 1 and No. 2.

For example, based on results for the third quarter TsDNG oil field No. 5 completed its work in 67 percent of the standard time, TsNDG field No. 1 in 86 percent of this allotted time, PRTsEO No. 2 in 50 percent of the standard time and PRTsEO No. 2 in 60 percent of the standard time.

Work is continuing on improving the conditions of competition between the shops and subcontracting organizations. In our opinion the following issues need to be resolved.

- 1) The number of new wells brought into production differs for every oil field and, obviously, those participants which bring in 7-10 wells in a quarter achieve reductions in the period to bring new well on-line with greater difficulty than those which bring in 1-2 wells. In this regard it is necessary to develop evaluational criteria for the work of each competitor which take account of specific conditions.
- 2) How are wells to be considered which pass into conservation after drilling. If our objective is to increase the incentives for oil fields to bring wells into production more rapidly, it is not clear whether it is proper to include the time when they are in conservation in the period of their outfitting.

COPYRIGHT: Izdatel'stvo "Nedra", "Neftyanoe khozyaystvo", 1984

9276

CSO: 1822/143

## OIL AND GAS

### BRIEFS

KUYBYSHEVNEFT' ABOVE PLAN OIL PRODUCTION--The collective of the Kuybyshevneft' Association was responsible for recovering 100 million tons of oil from the earth's depths during the 11th Five-Year Plan. Now they have already recovered 770,000 tons of oil above the plan after 2 years and 11 months in the fields. The workers of the Pervomayskneft and Zhigulevskneft administration made an especially large contribution. Their success is due to the accelerated coming on stream of new deposits, early completion of well construction and reduction of their repair period. [By A. Vorob'yev] [Text] [Moscow SOTSIALISTICHESKAYA INDUSTRIYA in Russian 10 Dec 83 p 1] 12421

DRILLING ON THE ZHDANOV SHORE--Cheleken--Drilling of new production well No 70 has begun on the Zhdanov shore. Its planned depth is 4,050 meters. The new artery should yield an industrial oil flow the strata underlying the terra rossa rock mass. For the first 2 days the drilling brigade of foremen A. Gamzatov and Kh. Khazriyev bored through the sea bottom to a depth of 236 m, which is four times deeper than planned. The expert fast-drilling foremen promise to hand over the well ahead of schedule. [By. V. Lebed'] [Text] [Ashkhabad TURKMENSKAYA ISKRA in Russian 9 Dec 83 p 1] 12421

SAKHALIN SHELF OIL EXPLORATIONS--Prospecting for shelf oil and gas condensate deposits is under way on the northeast shores of Sakhalin. Study of the shelf in the turbulent conditions of the Okhotsk Sea is being conducted by the Far East Deep Drilling Offshore Oil and Gas Prospecting Expedition of the Sakhalinmorneftegazprom Association. Shelf operations are being aided by the Okha self-lifting floating rig (SPBU). The drilling rig motor supply ship Lyutogahauls and provides the Okha SPBU with pipes, cement, chemical reagents and products. [Text] [Moscow IZVESTIYA in Russian 1 Nov 83 p 3] 12421

NEW PROSPECTING CONCEPT--Ufa (TASS)--Bashkir scientists developed a new concept of prospecting for mineral resources, which makes the Urals a region with a big oil and gas bearing potential. "We are associating the oil potential of Baskhiria and the Urals", explains the head of operations, Doctor of Geological and Mineralogical Sciences M. Kamaletdinov, "with an essentially new view of the geology of this region, namely the role which the main structural sections of the earth's core, the so-called mass over-thrusts, may play in oil prospecting. These thin sheets of rock thrust on top of each other are familiar to geologists and oil workers. However,

they are not usually associated with oil and gas bearing folds. Our proposed concept of the formation of the earth's core gives geologists another, more effective system of exploratory work: first to seek a thrust, then the mineral deposit folds strung over it. In as much as thrusts extending hundreds and even thousands of kilometers are being discovered in the region of the Volga and Urals, we believe that the oil and gas bearing potential of this region is much greater than we thought." [Text] [Moscow SOTSIALISTICHESKAYA INDUSTRIYA in Russian 11 Nov 83 p 2] 12421

GORSKNEFT' RECOVERY QUOTAS OUTSTRIPPED --Groznyy, 26 [Nov]--Workers of the Gorskneft' Oil and Gas Recovery Administration are considerably overfulfilling their quotas. This year they recovered 8,374 tons of oil, increased labor productivity by 1.4 percent, realized production worth hundreds of thousands of rubles above the quota, and saved more than 400,000 kw/h of electric power, more than 500 giga-calories of thermal power and about 20 tons of fuel unit. There is competition within the administration under the motto "High results for each working day". Here all the collectives work according to the brigade order method. Each shop has organized competition by profession. Among the best are I. Shuvayev, operator; N. Savchenko, driller; V. Tolmachev, fitter; V. Podgurskiy, mechanic; V. Inozemtsev, senior foreman. [By B. Artemenko, PRAVDA correspondent] [Text] [Moscow PRAVDA in Russian 27 Nov 83 p 1] 12421

GAS-LIFT SPEEDS OIL RECOVERY--Thanks to introduction of the gas-lift operating method of many wells, the Leninneft Oil and Gas Recovery Administration was able to stabilize recovery of hydrocarbon raw materials. Since the beginning of the year it provided the nation with more than 30,000 tons of oil and more than 20 million cubic meters of gas, recovered from the depths of the Karakums, above the basic quota. It successfully fulfilled the socialist obligation it assumed for the 3d year of the Five-Year Plan. The greatest contribution to labor victory was made by the collective of field No 1, headed by labor veteran, meritorious oil worker of the TSSR and recipient of the Orders of Lenin and the October Revolution, Anna Dzhaniev. [By D. Dzhaparov] [Text] [Ashkhabad TURKMENSKAYA ISKRA in Russian 9 Dec 83 p 1] 12421

WEST KAZAKHSTAN'S OIL PRODUCTION--Shevchenko--Oil workers of the Buzachi peninsula are successfully solving the problem of accelerated development of West Kazakhstan's oil riches. Yesterday the 10 millionth ton of raw material since the beginning of the deposit's development was recovered here ahead of schedule. Success was assured by the wide introduction of superior methods of increasing the yield of formations. Only 4 years ago the first drilling rigs appeared among the sands and salt marches of Buzachi. In order to recover oil here it was necessary to bypass traditional water pumping in favor of pressure maintenance in the underground strata: the water was unable to "force" the viscous oil into the wells. At the suggestion of scientists, they employed a polymer here. This sharply increased the deposit's productivity. Oil workers are also using thermal methods. Powerful generators force down steam heated to hundreds of degrees, which softens the gummy oil. [By TASS correspondent G. Groyser] [Text] [Moscow SOTSIALISTICHESKAYA INDUSTRIYA in Russian 12 Nov 83 p 1] 12421

CASPIAN OIL WORKERS GET SHIPS--Baku--New ships, the Neftegaz-3 and Neftegaz-26, built at the Polish National Republic wharves were added to the Caspian fleet. They will be used to service Shel'f-type floating drilling rigs, which are developing offshore oil deposits. The ships will transport platforms to the drilling site and deliver pipes, tools and construction materials to offshore drillers. When necessary these ships may be used for rescue work. In the future, Caspian oil workers will receive several more towing ships of the Neftegaz type. [By Sh. Medzhidov] [Text] [Moscow IZVESTIYA in Russian 25 Nov 83 p 2] 12421

OIL FROM CASPIAN'S DEPTHS--The fourth successive oil gusher occurred at the offshore deposit imeni 28 April. All four wells were drilled from a single stationary platform, installed in the middle of the Caspian, where the sea's depth reaches 100 m. From this platform, designed by the Baku Gipromorneftegaz Institute, 12 shafts will be drilled, dispersed in different directions by a blasthole ring. The slant method of drilling, of which the recognized experts are the Azerbaydzhani offshore oil workers makes it possible to reach from one of the islands the riches hidden in the deep parts of the sea. The brigade of foremen Gasanbala Isayev and Valid Mamedov drilled a well, the shaft of which was slanted 750 m from the vertical. Now in turn, they are on the fifth successive well. Oil workers have no doubt that it will yield a powerful oil flow. [By D. Melikov] [Text] [Moscow SOTSIALISTICHESKAYA INDUSTRIYA in Russian 1 Dec 83 p 1] 12421

CSO: 1822/104

COAL

SYNOPSIS OF ARTICLES IN UGOL' UKRAINY , DECEMBER 1983

Kiev UGOL' UKRAINY in Russian No 12, Dec 83 p 48

UDC 622.001.8:65.015.25 "sh. Krasnolimanskaya"

SOURCES OF GROWTH OF LABOR PRODUCTIVITY IN THE KRASNOLIMANSKAYA MINE

[Synopsis of article by V. F. Vereshchagin, pp 3-5]

[Text] Working conditions in the Krasnolimanskaya Mine, Krasnoarmeyskugol' Association. Achievements, technical-economic indicators. Reserves of growth of labor productivity. Two tables.

UDC 622.274.526

THE OPERATION OF INTEGRATED MECHANIZED LONGWALLS IN ARTEMUGOL' ASSOCIATION

[Synopsis of article by K. I. Komov, A. S. Kulinich, and A. A. Shak, p 6]

[Text] Results of operation of integrated mechanized longwalls in mines of Artemugol' Association. Proposals for further effective utilization of complexes.

UDC 622.232.72.65.012.1

NEW TECHNOLOGY OF HIGH-SPEED COMBINE TUNNELING

[Synopsis of article by M. G. Shetser, pp 7-8]

[Text] Experience of two-combine tunneling in Vinnitskaya Mine, Shakhterskantratsit Association. Two illustrations.

UDC 622.281:622.26.016

PROTECTION OF REUSABLE WORKINGS IN KOMSOMOLETS DONBASSA MINE

[Synopsis of article by I. Yu. Zaslavskiy, N. A. Boyev, and V. N. Churakov, pp 10-11]

[Text] Results of mine instrumental readings on the state of preparatory workings using various protection devices. Analysis of effectiveness of

protection ways and means. Rational passports of protection of reusable workings. Two illustrations.

UDC 622.272:624.138.4

#### TESTS OF POLYURETHANE COMPOUNDS TO REINFORCE UNSTABLE ROCKS

[Synopsis of article by V. K. Sal'nikov, I. M. Danil'chenko, Z. P. Kobrina, and I. R. Metlyakova, pp 11-13]

[Text] Results of laboratory and mine tests in the Donbass of West German and Soviet-made polyurethane compounds to reinforce unstable rocks in long-wall roofs. Two tables, two illustrations.

UDC 622.281.9 (088.8)

#### RATIONAL DESIGN OF MAN-MADE PILLARS AND TECHNOLOGY OF CONSTRUCTION

[Synopsis of article by A. M. Simanovich, pp 13-14]

[Text] Enhancing stability of extraction drifts during reuse, protecting man-made pillars with relief slots to ensure reduction of stress in rocks hindering excavation. One illustration.

UDC 658.155:658.114.61:622.33.012

#### DETERMINATION OF INTERNAL COST-ACCOUNTING SANCTIONS IN RELATIONS BETWEEN MINE SECTIONS

[Synopsis of article by A. N. Kravchenko and N. P. Gulyayev, pp 15-17]

[Text] Claims in cost-accounting relations between mine sections systematized. Procedure for determining amount of fines imposed for substandard or delayed fulfillment of reciprocal obligations taken into account when determining results of cost-accounting activities. Two tables, three references.

UDC 658.3.001.5:622.01

#### ENHANCING THE EFFECTIVENESS OF ADMINISTERING SOCIAL PROCESSES IN PRODUCTION COLLECTIVES

[Synopsis of article by N. S. Pochtarenko, V. V. Rudenko, and A. A. Lapteyev, pp 18-19]

[Text] Results of investigation of effectiveness of administering the social-psychological climate in labor collectives in mines of Donetskugol' Association by means of an integrated program of social-economic measures. Proposals to set up a section of the integrated program "Improving the Social-Psychological Climate of the Collective." One illustration, one reference.

UDC 658.27.004.14:658.012.2:622.33

MATHEMATICAL MODEL OF PLANNING TO REDUCE IDLENESS IN COAL EXTRACTION

[Synopsis of article by A. V. Litvintsev, V. I. Steshenko, and A. R. Tsyganov, pp 19-21]

[Text] Development and utilization of a model of a standard system of planning to reduce the level of idleness of the technological process (TISPLAN SUP TP). One table, two illustrations.

UDC 622.232.72.002.237 "2K-52 i 1K-101"

EFFECTIVENESS OF OPTIMALIZING OPERATING CONDITIONS OF THE 2K-52 AND 1K-101 COAL EXTRACTION COMBINES

[Synopsis of article by G. F. Lavrik, pp 21-23]

[Text] Criteria by which operating conditions of coal extraction combines are optimized. Relation between these criteria and effectiveness of coal production. Recommendations. Two tables, one illustration.

UDC 622.23.05

DONGIPROUGLEMASH EQUIPMENT FOR EXCAVATING THIN SLOPING SEAMS

[Synopsis of article by G. A. Litvinov and A. V. Galkin, pp 23-24]

[Text] Dongiprouglemash efforts in the field of mechanizing the excavation of thin sloping seams. Four illustrations.

UDC 622.232.8.001.4

INDUSTRIAL TESTS OF KMT EQUIPMENT COMPLEX

[Synopsis of article by Yu. A. Korovkin, V. I. Dvornichenko, and Yu. N. Gudyryn, pp 25-26]

[Text] Results of industrial tests of KMT equipment complex in Mine imeni Volodarskiy, Sverdlovantratsit Association. Two illustrations

UDC 622.619.4-82

MPK-3 HYDRAULICIZED LOADING MACHINE

[Synopsis of article by V. A. Atabekov, A. B. Pashchevskiy, and G. S. Knyaz'yan, pp 26-27]

[Text] Design and operating principles of experimental model of MPK-3 loading machine with side unloading of scoop. Conditions and results of tests of machines in Kholodnaya Balka Mining Administration and in Mine imeni Sotsialisticheskii Donbass. Two illustrations.



UDC 622.675.22

OPERATION OF MACHINE TO CLEAN MINE CARS

[Synopsis of article by B. Ya. Khutorovoy, p 28]

[Text] Layout and operating principles of machine to clear mine cars as recommended by rationalization experts. One illustration.

UDC 622.675.52

OK DUMPERS WITH VRP ENGINE DRIVE

[Synopsis of article by S. A. Ostapenko, V. G. Gubenko, and V. V. Lavrinenko, pp 28-29]

[Text] Enhancing the operational reliability of series-produced OK-type dumpers through the use of VRP-type engines in transmission. Results of mine tests of modernized drive. One illustration.

UDC 622.673-592.5

FUNCTIONAL QUALITIES OF PNEUMATIC SPRING-LOAD DRIVE OF BRAKING DEVICES OF MINE HOISTING MACHINES

[Synopsis of article by N. I. Shapovalov, pp 30-31]

[Text] An analytical analysis of functional characteristics of pneumatic spring-loaded drive of braking devices of mine hoisting machines. Qualitative evaluation of brake drive. Conclusions on the practicality of using spring-loaded brake drive in mine hoisting machines. One illustration.

UDC 621.315.684:622.01

STANDARDIZATION OF CONTINUOUS CURRENT-CARRYING TERMINALS

[Synopsis of article by B. P. Rybko and V. V. Shilov, pp 31-32]

[Text] Advantages and drawbacks of continuous terminals. Proposals for eliminating causes of damage to terminals. One reference.

UDC 622.411.33.1/.4:533.17:576.8

VALIDATION OF A MICROBIOLOGICAL TECHNIQUE FOR REDUCING EXCESS METHANE IN A WORKED-OUT SPACE

[Synopsis of article by V. I. Myaken'kiy, pp 32-33]

[Text] Microbiological action on caved-in rocks of worked-out space for purposes of reducing excessive gas, basic parameters of technique, results. One illustration.

UDC 622.831.322

CONCENTRATION OF PARAMAGNETIC CENTERS IN COAL SEAMS

[Synopsis of article by G. D. Frolov, V. N. Glukhodedov, and T. F. Peresun'ko, pp 33-34]

[Text] Results of studies carried out in Novocherkassk Polytechnical Institute to confirm that a concentration of paramagnetic centers is an indicator of burst hazard in coal seams. Two tables, three references.

UDC 622.812:614.839.53

DISTRIBUTION OF PRESSURE OF AN AIR SHOCK WAVE IN THE VICINITY OF SUDDEN NARROWING OR WIDENING OF WORKINGS

[Synopsis of article by A. M. Chekhovskikh, p 34]

[Text] Results of experimental studies of parameters of shock waves in the vicinity of an abrupt change in the cross-section area of a working. One illustration, two references.

UDC 622.837:624.21

EXPERIENCE OF UNDERWORKING A HIGHWAY BRIDGE IN THE WESTERN DONBASS

[Synopsis of article by I. Ye. Golovchanskiy, V. S. Martynushev, E. Ya. Gonskiy, and F. I. Mavrodi, pp 36-37]

[Text] A constructive solution for protecting highway bridges against the impact of mine workings. Positive experience of underworking a highway bridge in Pavlograd. Possibility of utilizing the experience in resolving the question of reactivating protective pillars under similar surface structures. Two tables, two illustrations.

UDC 622.26:622.232.72:622.23.08

DETERMINING THE SPEED OF COMBINE WORKING

[Synopsis of article by B. V. Grimm, pp 38-39]

[Text] Factors affecting the productivity of a tunneling combine. Formula for calculating the speed of working operations. Two tables, one reference.

UDC 621.928.235:622.01

NEW DESIGN FOR VIBROINSULATING SCREEN SUPPORTS

[Synopsis of article by S. F. Demenin, A. B. Kanibalovskiy, and A. F. Luk'yanenko, p 39]

[Text] Supports of new design for screens, offered by Gipromashugleobogashcheniye. Characteristics of the supports, advantages over spring supports. Two illustrations.

UDC 622.7.092:543.822.053.001.4

SHAPER OF COAL FLOW ON CONVEYOR

[Synopsis of article by A. M. Onishchenko, V. P. Belonozhko, and V. N. Zavrzhin, pp 40-41]

[Text] Layout, operating principle, and analytical functions of geometric parameters of shaper of coal flow on conveyor. One illustration.

COPYRIGHT: Izdatel'stvo "Tekhnika" "Ugol' Ukrainy", 1983

6854

CSO: 1822/141

## ALTERNATE FUELS

### MINING ENCYCLOPEDIA TO BE PUBLISHED

Moscow TORFYANAYA PROMYSHLENNOST' in Russian No 12, Dec 83 pp 31-32

[Unsigned review of "Gornaya entsiklopediya" [Mining Encyclopedia] Izdatel'stvo Sovetskaya entsiklopediya]

[Text] The "Sovetskaya entsiklopediya" Publishing House has announced the publication of a five-volume "Mining Encyclopedia" , the world's first such publication.

The encyclopedia's 8,000 entries give a popular discussion of minerals, rocks, commercial minerals and chemical elements, methods and processes of working and refining all types of mineral raw materials, the construction of mining facilities (including underground ones), nations with developed mining industries, the continents and oceans, safety, mining equipment, biographies of outstanding miners and geologists, geological theories, mining enterprises, mining industry sectors, environmental protection, economics, the history of mining, and other subjects.

Each term is accompanied by English, German, French and Spanish translations.

The "Mining Encyclopedia" is being printed by the multicolour offset method. This makes especially interesting the 3,000 illustrations of basic mining machinery, flowsheets, development systems and three-dimensional drawings, mining enterprises, examples of minerals, volcanoes, caves, geysers, etc.

A lot of information is provided by the 300 colored maps of the mining industry in the USSR and other nations, the main minerals and discussions of their genesis, mineral basins, and other features.

The editorial board of the "Mining Encyclopedia" includes very prominent Soviet specialists and organizers of the USSR mining industry. Prominent Soviet and foreign specialists are among the authors. The chief editor is Professor Ye. A. Kozlovskiy, winner of the Lenin Prize, doctor of technical sciences and a well known specialist in geological exploration work and the economics of minerals.

The "Mining Encyclopedia" will serve for many years as the main reference book for mining engineers and geologists in all specialities, teachers and students in mining and geological vuzes and tekhnikums. It is also addressed to geographers, economists, construction workers, metallurgists and machine builders.

The estimated price per volume is nine rubles. The first volume will appear in the first half of 1984. The "Mining Encyclopedia" can be purchased in any bookstore for subscription editions.

COPYRIGHT: Izdatel'stvo "Nedra", "Torfyanaya promshlennost'", 1983

11574  
CSO:1822/136

## ALTERNATE FUELS

SYNOPSIS OF ARTICLES IN TORFYANAYA PROMYSHLENNOST' , DECEMBER 1983

Moscow TORFYANAYA PROMYSHLENNOST' in Russian No 12, Dec 83 p 32

UDC 622.331.002.5.004.1

### OPERATIONAL RELIABILITY OF SERIES EQUIPMENT FOR REMOVING WOOD FROM PREPARATORY LAYER

[Synopsis of article by L. M. Malkov, F. S. Ponomarchyuk, pp 3-5]

[Text] Results from reliability studies of series equipment for removing stumps from preparatory layer. Formulas for calculating reliability indicators of MTP-42A and MTP-81 machines, depending upon the number of stumps. The distribution of reliability indicators for these machines depends upon exponential law and not upon the number of stumps. 1 table, 3 illustrations, 5 references.

UDC 622.331:65.012.2

### FORECASTING DAILY PEAT EXTRACTION

[Synopsis of article by N. V. Dialektova, pp 5-7]

[Text] Method of forecasting peat extraction based upon two-dimensional normal distribution. Forecast permits well based planning of peat extraction during rain free period. 1 table, illustration, 3 references.

UDC 622.812:658.562

### METHODS AND DEVICES FOR CONTROLLING STRENGTH OF PEAT BRIQUETS

[Synopsis of article by M. A. Gatikh, A. I. Zakablukov, V. A. Tsarev, pp 7-10]

[Text] Operation and design of discrete control system for peat briquet strength based upon the measurement of the effort required to chip off the briquet face. Test results. 3 illustrations, 4 references.

UDC 622.331:621.8.67.81

#### QUALITATIVE INDICATORS OF CUT PEAT DURING PNEUMATIC COLLECTION

[Synopsis of article by L. R. Davydov, Yu. I. Kozlov, V. I. Pravdin, pp 10-11]

[Text] Examines some qualitative indicators of cut peat. Shows advantages of pneumatic method of collecting cut peat compared to mechanical method. 1 table, 3 references.

UDC 631.86:631.878

#### USE OF PEAT-MANURE COMPOSTS IN GREENHOUSE VEGETABLE RAISING

[Synopsis of article by V. I. Lashnev, N. G. Korotkova and Z. N. Shufinskaya, pp 11-13]

[Text] Results of research on the use of peat-manure composts as the basic nutritive and biological additive in peaty soil in greenhouses for growing cucumbers and tomatoes. 2 tables, 2 references

UDC 622.331:584.5.002.5

#### PL-TPS FLOW LINE FOR THE PRODUCTION OF PEAT FEED ADDITIVES

[Synopsis of article by V. F. Kulikov, pp 13-14]

[Text] Process layout, operation and technical characteristics of PL-TPS flow line for the production of peat feed additives. 1 illustration.

UDC 622.331.002.5

#### STANDARDIZED NOISE INSULATED CAB FOR PEAT MACHINES

[Synopsis of article by Yu. V. Potekhin and V. S. Klimov, pp 14-15]

[Text] The U-27 noise insulated cab was developed with a view to the specific characteristics of peat machine operation (increased dust, temperature, solar radiation). It uses modern materials and accessories. 1 illustration.

UDC 624.131.52

#### STATISTICAL ESTIMATE OF DEFORMATION AND FILTRATION CHARACTERISTICS OF GENETICALLY CLASSIFIED PEAT

[Synopsis of article by V. I. Kosov, pp 16-19]

[Text] A covariance analysis of the relationship between deformation (compression) and physical-technical properties of various kinds of peat in the contemporary genetic classification system. Correlation equations are obtained which make it possible to predict peat deformation properties on the basis of their physical-technical characteristics. 4 tables, 5 references.

INFLUENCE OF EXTERNAL FACTORS ON SPONTANEOUS COMBUSTION OF PEAT

[Synopsis of article by V. M. Shpynev, pp 19-21]

[Text] Results from the theoretical and experimental study of the relationship between the intensity of the spontaneous combustion of cut peat in stacks and the simultaneous effect of external factors (solar radiation, air temperature, amount of residues, wind speed). 1 illustration, 2 references.

UDC 622.331:625.173.6

PROSPECTS FOR THE MECHANIZATION OF MAINTENANCE OF WAY WORK ON PEAT INDUSTRY  
NARROW GAUGE RAILROADS

[Synopsis of article by A. K. Filippov, pp 21-22]

[Text] Principles for the organization of maintenance of way on 750 mm track using heavy type track machinery in combination with first generation machinery and other equipment. 1 table.

COPYRIGHT: Izdatel'stvo "Nedra", "Torfyanaya promyshlennost'", 1983

11574

CSO: 1822/136



## NUCLEAR POWER

### DELIVERY PROBLEMS, EQUIPMENT SHORTAGES AT AES CONSTRUCTION SITES

#### Construction Schedules Not Met

Moscow MATERIAL'NO-TEKHICHESKOYE SNABZHENIYE in Russian No 9, Sep 83 pp 59-61

[Article by A. Gusev, section chief, State Committee for Material and Technical Supply (Gossnab): Taking Into Account the Actual Need; under heading "At the AES Construction Site"]

[Text] Comrade Yu. V. Andropov stated at the June 1983 Plenum of the CPSU Central Committee that the future of our energy sector lies, first of all, in the utilization of the most modern atomic generators. The Energy Program is an extremely important document on future prospects and constitutes a kind of GOELRO [State Commission for Electrification of Russia (1920)] for current conditions. The power sector builders are realizing the program and are building large atomic generating plants in various areas of the country, especially in regions poor in energy resources. In two years of the 11th Five-Year Plan, the Leningrad AES [atomic power plant] as well as the powerful generating units at the Kursk, Smolensk and other atomic plants became operational.

In the present year, the builders have engaged in socialist competition in order to complete and exceed their production tasks. In many ways, their success depends upon the construction sites being correctly supplied with materials, machinery and equipment. In the past, there has been considerable criticism of the suppliers and State Committee for Material and Technical Supply (Gossnab) departments. For example, when power plant builders were asked why they did not carry out construction and assembly plans they explained that they had not received reinforcement and angle steel, sheets and other types of rolled products at the proper time. And it was impossible not to agree with them. These materials really did arrive at the atomic power plant work sites with many interruptions. Certainly there were other reasons for delay, but the work was slowed down primarily by the lack of necessary materials.

It is usually the case that there are shortages in rolled steel products of 10-12 percent, and this incomplete supply makes it impossible to utilize what is on hand. This leads, firstly, to stoppages in construction and assembly work and secondly, to excessive stockpiling. At some work sites, hundreds of tons of metal have accumulated while the materials are intensely needed for construction at another destination.

The turning point occurred in the second half of last year when Soyuzglavmetall [Metal Production Main Administration] together with the All-Union Soyuzatom-energostroy [Main Administration for the Construction of Power Plants] Associations began to send plant suppliers specific production orders while the territorial units of USSR Gosnab established and compared schedules of rolled steel product deliveries and began to take into account the factual situation at the work sites and their actual needs for specific types of metal products. The result was that, by the end of last year, many metallurgical plants eliminated their debts by fully supplying atomic power construction sites with this type of materials. This year there are no serious metal supply breakdowns.

But this does not mean that all problems have been solved. As was noted by the resolution of the CPSU Central Committee and the USSR Council of Ministers concerning the improvement of supply discipline, the completion of planned production tasks as concerns orders and the necessary production deliveries by specified dates and with the required quality has not yet become the fundamental criterion for estimating the results of the economic activities of enterprises. Thus, some of them are continuing to supply rolled products which are not of the type ordered by construction organizations engaged in building atomic power plants. In the calculations on task completion according to the realized production volume, they show, as a rule, higher metal content profiles. Since the builders do not have other materials, they utilize what is on hand so as not to halt the work. But this leads to overexpenditure of metal.

Cases of supply breakdowns have not been fully eliminated. For example, the Chelyabinsk Metallurgical Plant allowed delays in shipping products both last year and this year. The Nikopol'skiy Southern Pipe Plant imeni 50th Anniversary of the Great October Revolution has not been able to overcome problems. More than once, its collective has been criticized by this magazine. Nevertheless, violations in supply schedules are not being eliminated. The enterprise was short 356 tons of stainless steel pipe in the first half of the current year alone.

Timely delivery of such pipes is of great significance because it is to be used for conduits in the Zaporozhye and Kalinin atomic power plants which are just coming on line. Therefore, the directors of the Nikopol'skiy Southern Pipe Plant should intensify organizational work so as to improve production and work discipline and link it directly to the execution of planned tasks and contractual obligations. It is necessary to make clear to the collective that their work is closely linked economically to power plant construction and that a supply failure disrupts production rhythms.

The resolution of the CPSU Central Committee and the USSR Council of Ministers demands that the USSR Gosnab increase the effectiveness of its work directed towards improving supply discipline and that contractual obligations be strictly observed by the enterprises. Much is being done in this area. In particular, the supply and marketing organizations of the UkSSR Gosnab have increased their activity as concerns the supply of necessary resources for atomic power plant

construction. However, their efforts directed at achieving observance of specified delivery times for pipes from the Nikopol'skiy Southern Pipe Plant imeni 50th Anniversary of the Great October Revolution still have not brought the desired result. Here, in our opinion, the Union and Republic Ministries of Ferrous Metallurgy should intervene more actively. They should take urgent measures in order to end the enterprise's work problem, increase supervision of its work and ensure that contractual supply arrangements are carried out fully and at the correct time.

It should be stressed that USSR Gosstab agencies are following closely the situation in the construction of atomic power plants and in accordance with this make appropriate corrections in the plans to supply them with construction materials. Thus, in the second quarter of the present year, deliveries of cement to the Zaporozhye Atomic Power Plant were increased by 6,000 tons which had been allocated for the fourth quarter. This was done because more concrete work could be accomplished at the plant than had been planned.

It should be noted that the USSR Minenergo [Ministry of Power and Electrification] has, unfortunately, not shown the necessary operational activity. It often carries out the distribution of material resources to projects in a formal way without taking into account the contractors' possibilities. For example, at the same time Zaporozhye Atomic Power Plant, in the first 3 months of this year, all the conditions were present which would have made it possible to lay down significantly more concrete than was specified by the construction work plan. However this was not done because Soyuzatomenergostroy Association allotted for the quarter a quantity of cement to the project amounting to only 20 percent of the annual needs.

Such practices bring nothing but losses to the collectives building the atomic power stations. They hold back the work effort and lead to failures to fulfill socialist obligations. We understand that Soyuzatomenergostroy's workers are trying to supply the atomic power plant work sites with materials throughout the entire year in a uniform way. Still, when preconditions are present for increasing the project construction rate, additional resources should be sought so that the work will not be delayed. But here close contacts are necessary between the plant constructors and the USSR Gosstab agencies. It would be possible to give quite a few examples of how their cooperation can make it possible to maneuver and direct resources, first of all to the place where the most need is felt.

In the current year, there are almost no complaints about Soyuzglavtsoment [Main Administration for Cement Industry] Administration, Souyzglavstroymaterialy [Main Administration for Construction Materials] and the Moscow and certain other territorial administrations. They are well informed as to the situation in atomic power plant construction and in the enterprises supplying the work sites with materials and they are taking measures to improve supply discipline. Their supply and marketing organizations are making an important contribution to the completion of the construction and assembly work involved in building atomic power plants.

But far from all the departments of the USSR Gossnab are working in this way. There are still many complaints about Soyuzglavles [Timber Products Main Administration]. During the first 5 months, its organizations failed to supply 21,000 cubic meters of timbers. The deliveries of Vostsiblessnabsbyt [Eastern Siberia Timber Supply Administration], Krasnoyarsklessnabsbyt [Krasnoyarsk Timber Supply Administration] and Arkhangel'sklessnabsbyt [Arkhangel'sk Timber Supply Administration] were especially unsatisfactory. As a result, plants manufacturing carpentry items and wood structures for dwellings and cultural and domestic items at energy plants and construction sites were forced to interrupt their work. The absence of these items and structures led to breaks in the work rhythm of the construction brigades and made it impossible to complete new living quarters at the planned time.

Soyuzglavsnabsbyts [Main Supply Administrations], Union Republic Gossnabs and main territorial administrations should remember that the correct delivery of materials, complete units and components is a necessary condition for the steady operation of atomic power plant construction. For this reason, supply discipline must be improved and insufficiencies eliminated so that there may be no interruptions in the delivery of necessary resources to the constructors of atomic power plants.

#### Responses to Editors Admit Errors

Moscow MATERIAL'NO-TEKHNICHESKOYE SNABZHENIYE in Russian No 9, Sep 83 p 61

[Response: "Reliable Supply Is Needed for Construction Projects"; editorial comment in boldface is shown indented]

[Text] In the article with the above heading (No 3, 1983), it was stated that several enterprises and organizations of the USSR Ministry of Ferrous Metallurgy and other government departments are not carrying out the technical and material supply plans for the construction of atomic power plants, are not complying with assigned production delivery dates and are not supplying the complete production order.

S.I. Pavlovskiy, chief of the Production Administration of USSR Minchermet [Ministry of Ferrous Metallurgy] reported to the editors that this criticism is correct. Last year, since production assignments for rolled steel products were not carried out, the ministry was not able to satisfy economic needs for this type of technical and material resources. In particular, the atomic power plant projects of the USSR Ministry of Power and Electrification were not supplied with the necessary types of metal and metal items. The ministry has taken the necessary measures to correct the problems in production supply for atomic power plant construction. In the first quarter of this year, the enterprises of the USSR Ministry of Ferrous Metallurgy delivered to these projects 66,700 tons of rolled products when the quota was 59,000 tons and their obligations have been completely satisfied.

[Response: "Analyze the Results, Derive Lessons"; editorial comment in boldface is shown indented]

In the article with the above heading (No 11, 1982), it was stated that the UkSSR Gossnab did not take the necessary measures in order to supply atomic power plant sites with rolled metal products. Its workers did not establish the necessary contacts with the supplier enterprises located within the Republic and with the construction organizations which build atomic power plants.

The deputy chairman of the UkSSR Gossnab, V. V. Melashchenko, informed the editors that the magazine's criticisms are accurate. Supply failures for rolled products and tubing last year were due to the fact that the republic's metallurgical enterprises did not fulfill production quotas.

In order to eliminate the noted deficiencies, the UkSSR Gossnab instructed Ukrglavmetall [Ukrainian Main Administration for Metal Production] and the Dnepropetrovsk and Donetsk Main Administrations to establish in the current year appropriate supervision of production deliveries from metallurgical plants, in particular, of tubing from the Nikopol'skiy pipe plant. This recommendation must be carried out.

COPYRIGHT: Izdatel'stvo "Ekonomika", "Material'no-tekhnicheskoye snabzheniye",  
1983

12497

CSO: 1822/71

## NUCLEAR POWER

### PLANNED DEVELOPMENT OF NEW SHEET ROLLING MILL AT IZHORSK PLANT

Moscow STROITEL'NAYA GAZETA in Russian 29 Jan 84 p 2

[Article by N. Andreyeva: "The Izhorsk Plant is Restored"]

[Excerpts] The leader of atomic machine building--the association Izhorsk Plant, whose renovation has become a model construction project of the country, is now experiencing unprecedented enthusiasm.

The figures testify eloquently to the scope of the work which has developed--during the past five-year plan, 320 million rubles of fixed production capital was put to work, and this indicator has to double in the 11th Five-Year Plan.

Today the association is producing reactor units of fantastic power--2 million kilowatts. In this connection, the builders, installers, and operators will be faced with many tasks. However, the main job is to put the first starter sheet rolling shop complex with a "5000" mill into operation by the end of the five-year plan.

There is a great requirement for such a mill because metallurgical production is not keeping pace with machine building which has been actively increasing in the association for the past seven years.

Atomic power engineering also makes great demands on steel. Moreover, at Izhorsk they are making equipment for the so-called first circuit, i.e., the reactor housing proper where uranium will be the main tester and receiver.

Such equipment is now being made on a "4000" rolling mill. However, it is not now coping with the work load which is growing rapidly at the present time. It is necessary, in the shortest time period, to replace the obsolete rolling mill with a new, modern one.

When it reaches planned capacity, it will produce 650,000 tons of sheets and plates a year. This is almost six times more than on the one in operation now. The "5000" will be the first rolling mill in the country that produces sheets and plates 4600 mm wide and from 10 to 450 mm thick from alloyed, stainless, and special steels as well as alloys.

Plans call for the first starter complex for the production of 120,000 tons of steel plate to be operational in 1985.

Some subcontractors are on site at the present time, the main one being the trust Sevzapstal'konstruktsiya [Northwest Steel Structural Trust]. This organization has not fulfilled its plan for a long time. But this is not because it has worked in a lazy manner. The facts are quite different--the Tula Metal Design Plant held up construction work on head soldering for several months. The Nizhniy Tagil metallurgists, in turn, really let this organization down.

This and similar misunderstandings have required socialist competition frontiers, in accordance with the "worker competition" principle, to be broadened. On the initiative of the Izhorstroy [Izhorsk Construction Trust] party committee, supported by the Kolpinskiy Ra [rayon committee] of the CPSU, the number of participants in the creative cooperation agreements was increased. Managers of steel-rolling, machine-building, and other plants located in different cities of the country, have themselves signed the agreement.

After the agreement was made, the Tula Plant finally fulfilled its task--it made deliveries, but the delay was too long. Now the installers, trying to overcome the lag, are working intensely, exceeding the norms. However, they opened only one, instead of two, bays by 1984. A part of the work was moved to this year. It was the same with equipment manufacture--the lag, which grew in the customer's association during past years, has not been overcome at the present time.

The fate of this giant depends today on everyone, be he a builder, customer, designer, or worker at a related out-of-town organization. What there is no time to do today, will be made up tomorrow with difficulty. This is why it is important for all participants in the construction not only to clearly observe everyday the schedule of joint work and to do everything to make up for what was neglected, but also to act with initiative, looking ahead. The participants in this model construction project of the country have decided to set aside crash work, and what must be regarded as of paramount importance, to set a clear pace and the most important production resource--worthy, high-quality work. The sheet rolling shop with the "5000" mill, the most powerful in the country, must be built on schedule.

8524

ССС: 1822/151

## NUCLEAR POWER

### BRIEFS

**KURSK AES CONSTRUCTION**--Kurchatov (Kursk Oblast)--The capacity of the Kursk AES/nuclear electric power station/ has grown by another one million kilowatts. Yesterday a commission accepted the station's third power block into permanent operation. The AES in Kurchatov, which already generates more than 70 billion kilowatt hours of electric power, played an important role in organizing this land and industrial complex which is based on the mineral resources of the Kursk magnetic anomaly. The construction of the AES continues--the foundation of the fourth power block has been laid. [Text] [Moscow TRUD in Russian 21 Dec 83 p 1] 8524

**SMOLENSK AES CONSTRUCTION**--Smolenskaya Oblast--The planned capacity of the Smolensk AES's first power block has become operational ahead-of-schedule. The construction of the second power block continues at a rapid pace. Desnogorsk, the power workers' settlement, is growing and improving. A 16-story building is being constructed here. [By R. Bikmukhametov] [Text] [Moscow IZVESTIYA in Russian 29 Oct 83 p 2] 8524

**INCREASED AES EQUIPMENT PRODUCTION**--The Znamya Truda association collective is increasing its contribution to developing our country's power potential. They have increased the output of steel fittings for AES's here. The first products of this now operational complex, as LenTASS/Leningrad branch of TASS/ reports, are being sent to the Zaporozh'ye, Kursk, Ignalina, and the other AES's under construction. In the current five-year plan, devices which regulate the movement of water and gases in the pipelines at the electric power stations have become this firm's main product. The designers are continually increasing the carrying capacity of this equipment. This lightens the work of the pumping system and allows the saving of a significant amount of electric power. Flaps, valves, and steel dampers which, on average, are twice as light and compact, have increased the reliability and quick response of this equipment. The association's collective is now preparing for series production of new-generation equipment which can operate automatically, on commands from a dispatcher's console. [Text] [Leningrad LENINGRADSKAYA PRAVDA in Russian 15 Nov 83 p 1] 8524

**IGNALINA AES START-UP**--Vilnius--The Ignalina AES, a leader in the new series of power enterprises, is on the verge of its start-up. This new five-year plan construction project got its name from the name of the city which stands halfway between Vilnius and Daugavpils. The chief sensation at the Ignalina



AES is the reactor. "If one depicts the development of scientific and technical progress in our industry in the form of an arrow pointed upwards"-- says the director of the electric power station, Lenin prize winner N. Lukonin--"then the Ignalina AES is at its tip. We are obliged, first of all, to our scientists for this. Not changing the design, not increasing the size of the standard "million-type" reactor, but only through the slight modernization of one of its junctions, they have been able to increase the power 1.5-fold. The power of two Dneproges's [Dneprovskaya Hydroelectric Power Station imeni V. I. Lenina]--1.5 million kilowatts, have been placed in today's reactor." The world atomic scene does not yet know such a one. The capacity of the Ignalina AES must reach three million kilowatts by the end of the five-year plan. And this indicator will be provided by the work of two, instead of three, reactors. [IZVESTIYA correspondent I. Kasyukov] [Text] [Moscow IZVESTIYA in Russian 28 Dec 83 p 2] 8524

ZAPOROZH'YE AES VKU EQUIPMENT--Leningrad--The manufacture of a full set of VKU [intraframe devices] for the second block of the Zaporozh'ye AES, which is under construction, has been completed at the Leningrad association Izhorsk Plant imeni A. A. Zhdanov. The VKU of the nuclear reactors must work with the accuracy of a clockwork mechanism and must be absolutely reliable. They ensure the effective operation of the reactor. The welders, machine operators, and assemblers must have intricate skills in order to create a perfectly functioning mechanism from multi-ton parts. It has happened before at times that atomic station installers, already having a considerable part of the equipment for the first circuit, were forced to wait for ages for VKU parts. Incidentally, there was also a similar lack of coordination which created certain difficulties in the construction of the Zaporozh'ye AES. The Izhorsk people now have a significant amount of work in progress. The complex which has now been prepared--the third, by count, since the beginning of the year--is intended for a block which is scheduled to become operational next year. A struggle to produce yet another full set required for the second block of the Yuzhno-Ukrainskaya AES by the end of the year has developed in the machinery and metal work assembly sectors. [By B. Pleshonov] [Text] [Moscow IZVESTIYA in Russian 16 Nov 83 p 1] 8524

CSO: 1822/151

## NON-NUCLEAR POWER

### HYDROELECTRIC POWER PROMOTED IN LITHUANIA

Vilnius SOBYTIYA I VREMYA in Russian No 19, Oct 83 pp 3-5

[Article by Yuozas Burneykis, correspondent member, LiSSR Academy of Sciences: "An Urgent Scientific-Technical Problem"]

[Text] Due to departmental and economic limitations and a number of other, subjective reasons, in solving the urgent energy problem we sometimes talk of clearly uneconomical and inefficient new energy sources. We thereby forget and underestimate the really effective, tested sources in our hands, requiring only organizational and technical measures. Among these is the energy of our rivers.

As is known, the republic's fuel and energy balance (FEB) is based exclusively upon fuel brought in from outside. Local resources only account for 4 percent, and hydroelectric power 1 percent. The future structure of the FEB will be as follows (in percent): organic fuels -- 80, nuclear -- 18, secondary energy sources -- 1.5, and hydroelectric power -- 0.5.

We must solve an important problem, that of reducing the consumption of organic fuel and making maximum use of local energy resources. This involves the energy of our rivers, which is only 10 percent used.

Also, the importance of dams and their reservoirs to the republic's economy is growing every year. They are being intensively built and operated. Electric power stations can thus become one of the components of the water resources complex. There are now more than 600 dams of varying sizes in Lithuania. According to preliminary data about 10 percent of them could be used for small scale hydroelectric power plants. Unfortunately, for a number of subjective reasons, this is not done.

The Kaunas GES is convincing proof of hydropower's efficiency. The prime cost per kWh of electric power produced by thermal electric power stations is 80, while for hydroelectric power stations it is only 0.14 kopecks. The Kaunas GES (producing about 380 million kWh annually) brings the economy about 2.5 million rubles of net profit (for the 23 years of its existence this amounts to about 60 million rubles). This amount of money could build another similar station at Nyamunas. When one looks at the investment recovery period rather than absolute efficiency, then it has already paid itself off seven times and will obviously still operate.

The conservation of organic fuels resulting from the use of hydropower is of inestimable importance. Every kilowatt hour from hydro saves about 340 grams of fuel. The republic's hydropower resources total about 3.5 billion kWh. If we were to use them we would annually save about 1.2 million tons of fuel. In view of the long term future where the demand for petroleum, for example, will be met through synthetic fuels, the costs of which are several fold higher than those of natural fuels, this deserves special attention.

The construction of a hydroelectric station requires more labor than it does to build a thermal electric power station. However, the operation of a GES (labor productivity here is 5-6 fold higher) makes up for this difference. The republic's GESes have about 740 fewer operating personnel than do thermal stations. Hydroelectric stations are thus very effective in reducing outlays of social labor, this is especially important in view of the unfavorable demographic situation.

In contrast to thermal stations they do not pollute the atmosphere or reservoirs. The value of such protection is not completely taken into consideration in the present methodology for comparison. On the other hand, GES reservoirs, especially on rivers in flat lands, require considerably greater areas than do thermal stations. Unfortunately, there are still no approved norms and methodology for estimating the value of flooded land. Therefore costs are often exaggerated.

The Food Program calls for every animal husbandry complex to be supplied by two independent energy sources. In order to handle accidents and natural calamities it is recommended that farms, animal husbandry complexes and large poultry farms be equipped with small electric power plants (in some cases a small GES would be suitable).

Unfortunately, so far the energy future is evaluated only with a view to the generation system's peak load capacity. This reduces the role of hydroelectric stations and enhances the role of pumped storage plants, which, from an engineering perspective, do not produce, but only use energy.

Why, in spite of all its advantages, is hydropower not being developed in the republic?

First of all because, as an analysis of the FEB shows, it does not solve the republic's energy problem, but only lessens it. The share of hydropower resources and their importance in the TEB are markedly declining with the development of large scale power engineering (Lithuanian GRES, Ignalina AES, and the Kayshyadoris Pumped Storage Station). This is why hydro has been neglected.

Secondly, the country's present methodology for the economic feasibility of electric power stations does not completely evaluate the advantages of hydroelectric power (renewable resource, labor savings, protection of nature, its reliability, etc.). Nor does it evaluate the shortcomings of thermal electric power stations (development of a fuel base, housing, transportation, working conditions in mines, and so on). It is therefore not surprising that the question has come up about refining the criteria for determining the efficiency of hydroelectric power production.

The third, and most objective reason is that hydroelectric stations in flat lands, where rivers have broad floodplains, require the inundation of large areas. However -- and we have to keep this under consideration -- we cannot obtain results without definite losses, in this case amounting to up to 10 percent of GES cost. In addition, there are engineering methods for reducing inundation: dikes, polders and other such installations. For example, in the flat lands of neighboring Latvia work is being completed on the construction of a series of hydroelectric stations on the Daugava River. This includes the Riga GES on its lower reaches.

Finally, a fourth reason: Our country is not now manufacturing hydraulic turbine generator units smaller than 25 megawatts. Also, there is no technical documentation for small hydroelectric station equipment. Without this it is impossible to design them or plan the reservoir site. Naturally, the problem of hydro equipment production should be solved on the scale of the entire country, or the European part of the USSR. Initially, it can be purchased in Czechoslovakia, for example.

An analysis of plans developed by Hidroproyekt [Hydroproject Planning and Survey Institute imeni S. Ya. Zhuk], shows that the comparative outlays per kilowatt are in the 600-800 ruble range at GESes on small and medium rivers in flat lands in, for example, Lithuania. This is close to the presently allowable costs (about 740 rubles per kilowatt) for GES construction in the European part of the USSR. Moreover, this latter figure has a tendency to grow.

In the U.S. the efficiency of small hydroelectric stations is evaluated in a similar manner. They are either marginally economical or uneconomical. However, hydropower is not subject to inflation.

In general, it can be asserted that if the price per kilowatt of a GES is twice as high as that of a thermal electric station, then they are equally worth building.

The entire world is now experiencing an increased interest in hydropower. While previously, as was the case in our country, small stations were neglected or closed down, their construction has now turned around in the U.S., France, the FRG, Sweden, Norway, the People's Republic of China, Czechoslovakia and in other nations. Special attention is being given to equipment for small stations on dams which have already been built.

Hydropower development in our republic is a scientific-technical problem whose time has come, it cannot be delayed. It could be part of the program for using the energy potential of large rivers (the Nemunas and Neris) and the construction of small hydroelectric stations.

In spite of the general benefits and the example of the Kaunas GES, the energy of the Nemunas River has not been further developed. Of all the stations in a possible series (Kaunas, Birshthonas, Druskininkay, Yurbarkas), the Birshthonas diversion GES is distinguished by the highest effective techno-economic indicators (according to our data for 1969, a kilowatt would cost about 200-300 rubles). For a long time now, specialists have been studying this site. Its efficiency would increase if it were to operate simultaneously with the Kaunas GES.

During the years of bourgeois rule, the Birshthonas GES was considered as extremely large with regard to power engineering in Lithuania. Today it is considered insignificant.

The biggest shortcoming of the Birshthonas GES is the large inundated area (especially part of the pine forest at Punya). Because of this it was not built. However, would this be worse than air pollution by dust, sulfur, and nitrogen oxides in the region around the Lithuanian GRES (with a capacity of about 600 megawatts)? From an operational perspective it seems that it would be more advisable to have an energy complex consisting of a 1,200 megawatt Lithuanian GRES and a 600 megawatt Birshthonas GES instead of the present 1,800 megawatt GRES. Moreover, the artificial reservoir would be useful to other sectors of the economy.

The efficiency of building the Birshthonas station with higher capacity equipment (up to 1,000 megawatts, and pumped storage units) is still under consideration. This involves sizable inundation. It is more advisable to consider a two stage alternative for the Birshthonas GES. For example, with an installed capacity of about 200 megawatts it would be sufficient to have a 15 meter dam (a 10 meter diversion dam and 5 meters with the backwaters of the Nemunas). This would avoid the inundation of sizable areas. In this case it would be possible to equip the Alitus GES with medium capacity units. It goes without saying that it is essential to find ways for reducing the flooding of the Nemunas.

The use of the Neris is not exhausting the river's power resources, but is of importance for comprehensive utilization. The Turnishskaya GES above Vilnius would be the most acceptable. As is the case with the Kaunas reservoir, its waters would serve other purposes: the regulation of water levels near towns, the creation of artificial high waters in connection with water supply to Minsk, industrial water supply, aquaculture and recreation.

With regards to the development of hydropower resources of other rivers, attention should first of all be directed towards potential stations on medium size rivers (the capacity of which would exceed two megawatts, installing equipment in the .5 to 10 megawatt range and building 5-20 meter high dams.

Small scale hydropower should also develop through the reconstruction of existing dams and equipment at small electric stations. According to preliminary data several dozen reservoirs are suitable for this purpose. The construction of small stations at existing dams is tentatively two fold less costly. Naturally, it is necessary to coordinate this with other aspects of comprehensive water management: irrigation, aquaculture, etc.

Small stations need hydraulic turbine-generator units with automatic control, consisting of standardized components and parts and special sets. It is also essential to have the appropriate electrical engineering. Practical experience shows that bulb type turbine units are most suitable for small hydroelectric stations.

It appears that small GES equipment should operate without any special control systems. It is desirable to have the widest possible assortment of equipment for

heads of more than 5 meters and capacity exceeding 0.05 megawatts. In addition, standard plans for the structures of small stations and for construction organization would bring considerable efficiencies.

The program for the development of small rivers' energy resources should be implemented in three stages: the determination of conditions for the construction of hydroelectric stations and the production of electrical energy, the problem of turbine-generator units and the preparation of standardized plans.

Experience shows that here it is essential to use state resources as incentives: granting loans to prepare GES plans and for construction, the regulation of conditions for connecting small stations to the system, determining the cost of hydroelectrical energy, etc.

We formulate some conclusions:

Firstly, the construction of hydroelectric stations will not solve Lithuania's energy problem, however, it can help ease it; therefore, incentives should be provided;

Secondly, it is necessary to have a new, improved methodology for the economic feasibility of hydroelectric stations, which would objectively estimate their economic and social effects;

Thirdly, the construction of hydroelectric stations in the republic is an urgent scientific and technical problem, consisting of the determination of the degree to which they are economical, the conditions of energy supply, the development of technical documentation, equipment and standard plans.

COPYRIGHT: IZDATEL'STVO TSK KP LITVY "SOBYTIYA I VREMYA," 1983

11574  
CSO:1822/170

## NON-NUCLEAR POWER

### MOSCOW REPLACING HIGH POWER OVERHEAD LINES WITH UNDERGROUND ELECTRIC CABLES

Moscow IZVESTIYA in Russian 9 Nov 83 p 1

[Article by B. Aleksandrov: "Underground Electricity"]

[Text] The replacement overhead power lines with underground electrical transmission cables will make it possible to free up 200 hectares of city property in Moscow during the 11th Five Year Plan.

The openwork towers of electrical transmission lines have become one of the marks of our industrial age. They have become commonplace in cities as well. In Moscow, for instance, electricity "corridors" with a tension of 110,000 volts now extend for 580 kilometers, with 220 kilovolt LEP [power transmission lines] not far behind at 340 kilometers. There is even a 40 kilometer section of very high tension lines of a half million volts within the Moscow city limits.

The first underground electrical power lines was laid in Moscow from the Izmaylovo substation to Cherkizovo prior to the Great Patriotic War, and is still operating reliably today. Much has been done recently to bring more underground electricity transmission lines into service.

In the vicinity of Butyrskyy Khutor, where a 10 hectare lot had been cleared, a street of residential dwellings appeared instead of "streets" of metal towers.

The issue of replacing overhead transmission lines with underground cables is more difficult in built up areas where open land, for all practical purposes has been exhausted. Designers of the "Mosenergoproekt" institute, in conjunction with specialists of the Genplan institute of the city of Moscow, the Moscow Energy Generation Institute and the city cable network have put together a program of such projects composed of six top priority sites: in Otradnyy, along Profsoyuznaya Street, in Zamoskvorechye and Kuzminki, as well as along Grayvoronovskaya Street and Volzhskiy Boulevard.

From an engineering viewpoint, the replacement of surface with underground lines is a very complicated problem. To maintain the necessary pressure in oil filled cables over a 3-4 kilometer stretch automated facilities the size

of a 3-story building must be built. These lines require separate cathode grounding insulated from the water main and heating main grids so as to protect the inhabitants from the possible penetration of high tension electricity into their apartments.

One day this electrical "underground" made itself known with an unusual event. In the vicinity of Volgogradskiy Prospeky a line suddenly went dead, and the culprits in the incident turned out to be poplar trees. They had excessively dried out the soil and the transmission line had overheated. It was necessary to manufacture a special watering machine. for this part of the line.

There is an immense amount of infrastructure hidden in the bowels of Moscow. Therefore, the subsequent addition of yet another solid line is, as a rule, far from easy. It is forbidden to dig trenches along large city avenues and in squares (especially in the center of Moscow). It is therefore necessary to dig the power transmission tunnels using mining techniques. Now, for instance, construction is proceeding on substations with a deep lead-in, with energy to come from Krasnaya Presnya. The "bridge" across the Sadovoye beltway is being dug with the help of a tunnel shield....

The inherent complexity of laying underground cable lines under urban construction conditions means that they turn out to be 10-15 times as expensive as the usual "overheaders". But nevertheless, calculations have shown that the erection of housing on land made available this way winds up being less expensive, since the needed utility and service lines can be run right next to them.

The more rapid underground concealment of powerful urban transmission lines will help to get production going of so-called dry cable. One kilometer of this cable is now undergoing production tests. It is designed to carry current of up to 120,000 kilowatts. The main objective of the testing is to determine its reliability. This type of cable is ideal for operations under the conditions of the powerful energy generation systems of Moscow and other major cities.

9276

CSO: 1822/119



## NON-NUCLEAR POWER

### FIRST DIRECT-CURRENT POWER TRANSMISSION LINE UNDER CONSTRUCTION IN KIRGHIZIA

Frunze SOVETSKAYA KIRGIZIYA in Russian 21 Dec 83 p 4

[Article by B. Plotnikov: "For Future Power Generation"]

[Text] The first direct current transmission line in the USSR is being built in Kirghizia. It was designed and is being built on the initiative of the researchers at the republic's power industry scientific research division. Strung at an altitude of 3,000 m above sea level, this new LEP [Electric Power Line] will link the Tyuz-Ashu and Susamyр substations.

We asked one of the designers of this project, the well-known power generation scientist, Candidate of Technical Sciences, B. A. Botbayev, to tell us about it.

"The intensive development of the mountain regions of our area", Bolot Asanovich stated, "requires the transmission there of great quantities of energy. To accomplish this we must build and build electricity transmission lines. Building and operating them in the conditions of Tien Shan [mountain range] is a very complicated matter. The builders must constantly overcome narrow and torturous mountain ravines, put towers on the steep banks of rivers and in areas of rockslides, mud flows and snowdrifts.

Particularly dangerous zones must be avoided, but in other locations it is necessary to erect expensive protective structures. All of this not only involves work but also represents the loss of significant amounts of time and resources. The operation of such lines is also not easy. Strong winds, ice loads and thunder storms all put LEPs out of commission, and repairing them is not only difficult, but also expensive, the more so since power transmission lines are far from inhabited areas. The necessity of providing special protective structures means that the cost of mountain power transmission lines turns out to be four to five that of a normal line on flat terrain.

All of these difficulties in the construction and operation of mountain LEPs are more than sufficient to stimulate constant thinking about ways to improve them, make them less expensive, and to increase their reliability. And today one adds to all of these the need for strict economies with every

kilowatt of electrical energy. This is the reason that the scientists of our department proposed the construction of a LEP for direct current instead of a surface line for the transmission of alternating current.

Such lines are much more economical, since less electricity is lost in them. Direct current lines require no protection from thunderstorms, make more economical use of metal, and reduce the probability of accidents. On these new lines it is possible to use only two wires instead of the three that are essential for alternating current LEPs. Because of this, climatic loads on the towers and lines themselves are reduced, as are the construction dimensions.

Specialists at the Kirgiz Power Industry Scientific Research Division are making an important contribution to the resolution of energy generation problems. In its laboratories, high altitude stations, and testing facilities research is being conducted on the comprehensive exploitation of the natural resources of the Issyk-Kul oblast and the Chuy Valley regions. In addition, an original technique has been developed and is being implemented for deep earth soundings to predict earthquakes.

These specialists have calculated that during the last 2 years alone the economic impact within the republic implemented projects from this division has amounted to about 3 million rubles."

9276

CSO: 1822/119

## NON-NUCLEAR POWER

### BRIEFS

OSSETIA-GEORGIA POWER LINKAGE--Ordzhonikidze--A surface electricity transmission line with a tension of 110 kilovolts has been put into operation between the Ezmin [hydroelectric power station], located in North Osetia, and the village of Kazbegi, located in the high mountain region of the Georgian SSR. Until 1976, the remote Kazbegi Rayon of the neighboring fraternal republic received electricity from a single power transmission line from the Georgian energy generation system which passed over the Main Caucasian Ridge through the high Krestovyy Pass. In the dead of winter several avalanches put this energy channel completely out of commission, after which the Georgian Power System called on its colleagues from Sevkavkazenergo for fraternal assistance. A temporary "overheader" was quickly built with a tension of 10 kilovolts from the main facilities of the Ezmin GES to Kazbegi. But this line could transmit only a limited amount of power, and only the most important energy users in the Kazbegi Rayon received electricity. "The power industry workers of North Osetia took it upon themselves to strengthen this energy bridge," the foreman of the Sevkavkazenergo Directorate, A. Velichko tells us. "This new surface line of about 25 kilometers in length was erected under severe mountain conditions. [By V. Artemenko] [Text] [Moscow PRAVDA in Russian 8 Oct 83 p 1] 9276

POWER LINES NEAR CHARA--Chita--Electricity from the Ust-Ilimsk GES was received for the first time by the inhabitants of Kuanda, a new settlement along the BAM [Baykal-Amur Main Line] which is the base for the builders of the Chita portion of the railway line. The LEP-220 [220kv Electric Power Line] is nearing Chara, the place where the final spike will be driven and the linking up take place of the railway lines of the Buryat and Chita portions of BAM. Less than 150 km now separates them. [Text] [Moscow SEL'SKAYA ZHIZN' in Russian 26 Oct 83 p 1] 9276

EKIBASTUZ-URALS LINE OPERATIONAL--Pavlodar Oblast--Energy from the Ekibastuz GRES-1 [State Regional Electric Power Station] has reached Kokchetav: the first section of the Ekibastuz-Ural alternating current LEP with a loading tension of 1,150 kilovolts is operational. Unique in its capacity, this LEP "marched" to the steppes of Kokchetav. This was neither a long or a short distance--600 kilometers. The 46 m high LEP towers have all been erected as well on the Kokchetav-Kustanay segment of the second section. This segment should become operational in 1985. This very long distance power transmission line is slated to become fully operational in the next 5 year plan. [By V. Bugayev] [Text] [Moscow TRUD in Russian 25 Dec 83 p 1] 9276

ENERGY BRIDGE OPERATIONAL--Ekibastuz (KazTAG)--Energy from the Ekibastuz GRES-1 has reached Kokchetav. The first section of the very long distance Ekibastuz-Ural Power Link has been loaded with a tension of 2,150 kilovolts. The high towers of this unique LEP have moved across almost 600 km of steppe, swamps, and rivers. During their erection, the builders implemented an effective assembly technique comprised of four worker lines. First came the brigades of foundation layers, who put together the immense foundations for the power transmission towers. The towers themselves reached the site as modular units, which were assembled together and erected immediately after the foundation was prepared. The builders of the third and fourth lines put insulators in place high up on the towers and strung the wires. The assembly of this power link took place simultaneously from Ekibastuz and from Kokchetav. In spite of the numerous difficulties, the builders completed work on the first section of the LEP and the huge transformer facilities located at the beginning and the end of this energy river within tight deadlines. Until the startup of all the transmission lines the working tension of the current reaching Kokchetav will be 500 kilovolts [Text] [Alma-Ata KAZAKHSTANSKAYA PRAVDA in Russian 25 Dec 83 p 1] 9276

BESKARAGAYSKIY RAYON GETS POWER--Semipalatinsk--Electricity is being delivered to the Beskaragayskiy rayon along a new LEP 110. Construction has started there on a large, 80,000 hectare irrigated tract of land. A powerful pumping station which will pump the waters of the Irtysh over to the fields will be the main energy user. The assemblers of the Kazelectrosel'stroy Trust strung the wires of this new LEP, under difficult conditions, over the Irtysh River, completing all their work on schedule. [By E. Matskevich] [Text] [Moscow IZVESTIYA in Russian 1 Nov 83 p 1] 9276

GEORGIA, NORTH CAUCASUS ELECTRICITY LINK--Tbilisi--A new, more than 24 km long power transmission line has linked up the energy systems of Georgia and the North Caucasus. The facilities for it were constructed in difficult high mountain conditions. The LEP passes through a narrow corridor of the Daryal Ridge. Now the inhabitants of these mountain regions will be fully supplied with electricity, even during the high use fall and winter period. [By T. Chanturiya] [Text] [Moscow IZVESTIYA in Russian 4 Nov 83 p 3] 9276

ANGARA-BOGUCHAN LEP OPERATIONAL--Irkutsk Oblast--A 220 kv electric power line operational at the construction site of the fourth hydroelectric power station at the Angara Cascade-Boguchan GES. This 3 km energy bridge has been strung across the Angara on 150 m towers, a unique operation that carried out by surface power industry assemblers headed by A. Kochnev of Bratsk. The transmission of energy to the right bank of the Angara makes it possible to develop rock excavation along a broad front and to begin preparations for the damming of the river, which is slated to be accomplished next year. [By N. Krivomazov] [Text] [Moscow SOTSIALISTICHESKAYA INDUSTRIYA in Russian 18 Nov 83 p 1] 9276

CSO: 1822/119

## PIPELINE CONSTRUCTION

UDC 621.643:621.791

### TECHNIQUES FOR SPEEDING PIPELINE CONSTRUCTION DESCRIBED

Moscow STROITEL'STVO TRUBOPROVODOV in Russian No 11, Nov 83 pp 9-11

[Article by A. G. Mazel' of VNIIST [All-Union Scientific-Research Institute for Trunk Pipeline Construction]: "Reserves for Increasing the Rate of Advance for Welding Columns of Integrated Flow-Line Operations Groups"]

[Text] During erection of the linear portion of trunk pipelines, integrated flow-line operations groups, which do welding, earthmoving, insulating and pipelaying work, are providing Minneftegazstroy [Ministry of Construction of Petroleum and Gas Industry Enterprises] with a high rate of construction. While several years ago the goal for the rate of advance of one such group was 100 km of finished 1,420-mm diameter pipeline per year, in 1983 the best flow-line groups (of comrades Belyayeva, Kushka, Volkova and Mikhel'son) are to lay 200 km each during the year.

In integrated flow-line operations groups, the main job that determines the rate of advance is welding. A high pace of welding and erecting can be assured only where there is timely engineering preparation of the right-of-way and where adequate numbers of pipe sections have been sent out ahead of the advancing welding column.

As VNIIST research has indicated, a column's best rate of advance and best work quality are achieved through the specialization of welders and by mutual monitoring among them [1]. The principle of fine breakdown of welding and erecting operations, which has been laid down as the basis of assembly-line pipeline welding, is now in use everywhere, thanks to the work of VNIIST and the Gazstroy Mashina Special Design Office on creating high-speed VSTs-type cellulose-coated electrodes [2] and [3] and special interior centering guides [4] and on developing the organizational principle of structuring welding columns for building pipelines of various diameters [5].

Technical and economic calculations on the effectiveness of welding pipelines 529-1,220 mm in diameter that were conducted back in 1969 indicated that flow-line methods for welding and erecting work, especially where cellulose-coated electrodes were used, were extremely effective in terms of both equated expenditures and labor expenditures [6].

With flow-line construction of 1,420-mm diameter pipelines, the lead team, which assembles the pipeline and welds the first layer of the joint into the

continuous strand, can work at a pace of 5 joints per hour [1]. In this case, where the lead team's total worktime is 12 minutes, four welders spend 7 minutes on the welding proper of the joint's root layer, using cellulose-coated electrodes, and the remaining 5 minutes are spent just on the auxiliary operations (setting the pipe section up on the centering guide, centering the joint and determining the gap, preheating, moving the centering guide, and moving the pipe section and placing it on the rod).

The rate of advance of the welding column rises considerably when the lead team's worktime is reduced. Thus, cutting the time by 20 percent (2.4 minutes) and by 30 percent (3.6 minutes) enables the rate of the work's progress to be increased by, respectively, 25 and 43 percent. A 50-percent reduction in the lead team's worktime (6 minutes) doubles the pipelaying pace. Thus, integrated flow-line operations groups can increase considerably the pace of welding and erecting work with even a relatively small saving in time at the various stages of the lead team's work.

Let us examine possible ways for saving time in cases where, because of the high skills of welders and assemblers, a backing run on the joints inside the pipe is not necessary.

A substantial gain is achieved when electrical welders, in making the root layer of the joint, are not distracted by such operations as changing electrodes, cleaning craters, adjusting the current, and dragging cables and tools from joint to joint. If these operations are charged to assistants, who are always present during each weld, then the time for four welders to weld a joint's root layer of, for example, a 1,420-mm diameter pipeline, is cut by almost 3 minutes, and the column's rate of advance through this measure alone is increased more than 25 percent.

Time can be saved also by improving the assembling operation. Under the organization for welding and assembly that is being used, it is necessary each time to thread the section being centered onto the 36-meter rod of the interior centering guide. This operation is performed by a pipelayer, which makes shuttle movements of great magnitude. The welding of a joint of pipe section A with the continuous strand is shown in position I (figure 1). A pipelayer 3 holds section A while a bulldozer 2 engages the centering guide 1 to the rod. After the joint's whole perimeter has been welded with the first layer, the centering guide is pulled out by the rod from section A, as shown in position II. Pipelayer 3 lowers section A onto the knife-edge support and moves to pipe section B, which it places on the centering guide's rod, as shown in position III, figure 1. At this time, bulldozer 2 takes up its initial position in order to set up the knife-edge support for the appropriate straight stand for deploying the welders.

Given the lead-team work scheme shown in figure 1, the use of two pipelayers can reduce the time taken by the operation, by pulling the pipe section to be centered more rapidly. However, the use of the machinery in this case will not be effective enough. The magnitudes of the pipelayers' movements can be reduced if self-propelled centering guides are used. In this case, the pipelayer should not put the 36-meter long pipe section onto the centering guide's rod. The use of two pipelayers becomes more rational (figure 2). The use

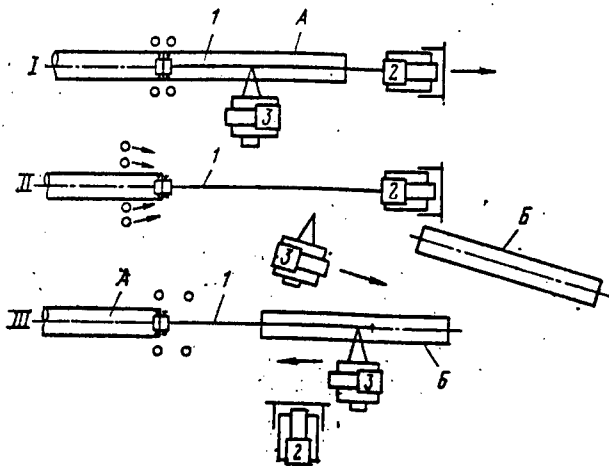

Figure 1. Scheme for Operating with a Centering Guide That Has a 36-Meter Long Rod.

A and B are 3-pipe sections.  
 1 is the centering guide's rod.  
 2 is a bulldozer.  
 3 is a pipelayer.  
 0's are electrical welders.

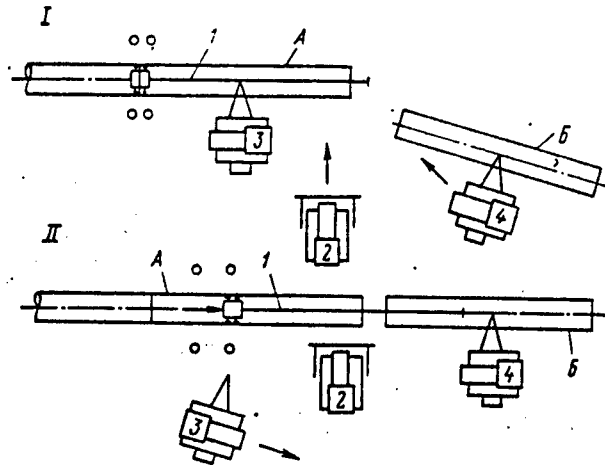

Figure 2. Scheme for Operating with a Self-Propelled Centering Guide.

The legend is the same as for figure 1, except that pipelayer 4 has been added.

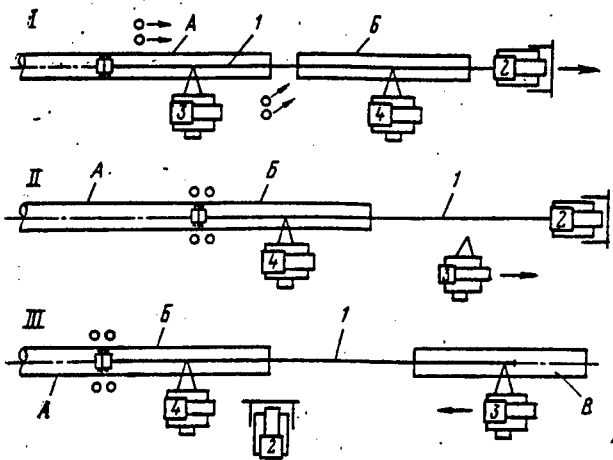

Figure 3. Scheme for Operating with a Centering Guide That Has a Rod 75-77 Meters Long.

The legend is the same as for figure 1, except that pipelayer 4 and pipe-section B have been added.

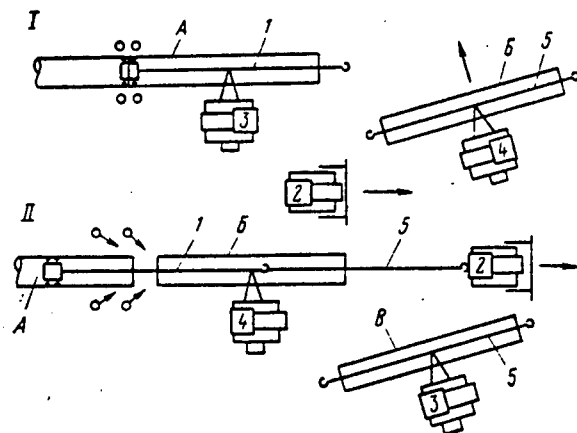

Figure 4. Scheme for Operating with a Centering Guide That Has a Long Separable Rod.

The legend is the same as for figure 1 except that pipelayer 4, pipe-section B and packaged light-weight pull rods 5 have been added.

of a self-propelled centering guide, moreover, will prevent waste of time of the machinery (the bulldozer or the pipelayer) during the periodic pulling of the centering guide from the pipeline by the rod in order to get it into the starting position for assembling the next joint. A rod in such a centering guide is necessary only for feeding it and for recharging. A self-propelled interior centering guide can be combined with welding heads that work inside the pipeline and can provide for not only an increase in assembling productivity but also for automation and for increasing productivity and raising the quality of the welding of the joint's root. Such a centering guide will enable an automatic welder to double the rate of advance of the welding column.

In the absence of self-propelled centering guides, it is desirable to use a centering-guide rod up to 75-77 meters long [7]. By using two pipelayers, such a rod will enable work to be performed simultaneously on two joints (figure 3). In this case, while the joint's root layer (between sections A and B) is being welded on the centering guide, the joint between sections B and V is being prepared for welding (the second section is being threaded by pipelayer 3, the rims of the joint are being preheated, and so on), and the centering guide in this case is shifted to the joint that has already been prepared completely for assembly.

To avoid the threading of sections on the lengthened rod, it is desirable to make the latter a component of two parts. In this case (figure 4), the centering guide can be used with an ordinary rod, 36 meters long, inside which are all the necessary service lines for controlling the centering guide, while several additional packaged pull rods 5, which are 38-39 meters long, will have been placed previously by assistants into the pipe sections that are to be centered, and they will be transported by the pipelayer, together with the pipe sections, and will be coupled with the centering guide's main rod, just immediately before movement of the centering guide to the next joint.

The use of self-propelled centering guides or a separable long rod will let assembly time be reduced by 15-20 percent. The use of separate preheaters at the ends of pipe sections prior to assembling them should give a definite gain in time when preparing a joint for welding. The preheaters, in order to increase their efficiency and to reduce preheating time, should be internal. Rotating the preheater, thanks to the jet action of the stream of hot gas, should in this case improve the uniformity of heating the pipe end. A calculation indicates that, under the technology for separate preheating of the ends prior to assembling the joint, the required temperature of the rims is retained for an adequately long time. Thus, for pipe 1,420 mm in diameter and 17 mm in wall thickness, with a carbon equivalent of 0.41 percent, for example, at an air temperature of -50 degrees C and a wind speed of 15 m/sec, when the end of the pipe has been heated to 200 degrees C over a distance of 300 mm the temperature at the rims is reduced to 100 degrees, the required value for preliminary heating, only after 14 minutes. This is completely adequate for the lead team to carry out all the assembling and welding operations.

Increase in the rate of advance of the welding column's lead team increases the number of joints of the pipeline strand that are assembled and welded by the first layer of the joint. This will require a corresponding increase



in total manning of the column. Increasing the number of welders or extending the column's work front can be dispensed with if the Styk-type installation, which welds with a self-protecting flux-cored electrode and uses a special means for containing the welding bath, welds the filling and facing layers.

Thus, there are definite reserves for further increasing the rate of advance of welding columns when large flow-line operations groups erect pipelines.

#### BIBLIOGRAPHY

1. Instruktsiya po premeneniyu potochnykh metodov proizvodstva svarочно-montazhnykh rabot ukрупnennymi brigadami pri stroitel'stve magistral'nykh truboprovodov [Instructions on the Use of Flow-Line Methods for Performing Welding and Erecting Operations by Augmented Brigades During the Construction of Trunk Pipelines (VSN 2-70-76)]. Moscow VNIIST [All-Union Scientific-Research Institute for Trunk Pipeline Construction], 1977.
2. Vornovitskiy, I. N. and Mazel', A. G. "The Development and Study of Electrodes with Organic Coatings for Welding Trunk Pipelines." Trudy VNIISTA [Transactions of the All-Union Scientific-Research Institute for Trunk Pipeline Construction], Moscow, No 16, 1983.
3. "Electrodes for Manual Arc Welding in Construction." Catalog, VNIIST-MOSZ, Moscow, 1982.
4. Branch Standard "Internal Hydraulic Centering Guides." OST [Branch Standard] 102-36-76. SKB [Special Design Bureau] of Gazstroymashina, 1976.
5. Mazel', A. G. and Burlakova, R. P. "The Use of Internal Centering Guides During the Assembly and Nonoverhead Welding of Joints," STROITEL'STVO TRUBOPROVODOV [Pipeline Construction], No 7, 1962.
6. Tekhniko-ekonomicheskiye rekomendatsii po vyboru ekonomicheskikh metodov svarki i organizatsii svarочно-montazhnykh rabot na stroitel'stve magistral'nykh i promyslovykh truboprovodov [Technical and Economic Recommendations on Choice of Economical Methods for Welding and for Organizing Welding and Erecting Operations During the Construction of Trunk and Oil-field Pipelines]. ONTI VNIISTA [Joint Scientific and Technical Publishing House] of the All-Union Scientific-Research Institute for Trunk Pipeline Construction, Moscow, 1969.
7. Moroz, A. K. "Study of the Organization of Flow-Line Construction of the Linear Portion of Trunk Pipelines," STROITEL'STVO TRUBOPROVODOV, No 2, 1983.

COPYRIGHT: Izdatel'stvo "Nedra" "Stroitel'stvo truboprovodov", 1983

11409

CSO: 1822/132

## PIPELINE CONSTRUCTION

UDC 621.643.002.2/331.875.3

### FACTORS IN CHOOSING MACHINERY FOR HIGH-SPEED PIPELAYING UNITS ANALYZED

Moscow STROITEL'STVO TRUBOPROVODOV in Russian No 11, Nov 83 pp 11-12

[Article by A. V. Karasev of a section of NIIOUS [Scientific-Research Institute for Organizing Management in Construction] under MISI [Moscow Construction-Engineering Institute] imeni V. V. Kuybyshev, Moscow, and O. Ya. Kinakh of a section of NIIES [Scientific-Research Institute for Construction Economics] of USSR Gosstroy, Minsk: "The Selection of Equipment for High-Speed Columns"]

[Text] The efficient operation of integrated trusts is supporting the rapid pace of increase in the recovery and transporting of oil and gas from West Siberia.

An integrated trust is an organizational entity that includes all the services for building the linear portion of trunk pipelines.

The structure of operations for trunk pipeline construction is unusual: 18-21 technological operations are united into groups (operating processes), whose number varies from 5 to 11. The operating processes are: subdividing the right-of-way, clearing it of trees, constructing haul roads, importing pipe to the right-of-way, welding the pipe, excavating the ditches, insulating and pipelaying, backfilling the ditches, arranging for means for chemical protection, erecting underwater crossings, testing and so on.

The operating processes make up a single flow-line operation. The operating processes are distributed among bottom-level pipeline construction organizations in such a way that each participates at a definite operating stage and is specialized in performing definite types of work. Line construction organizations at the lowest level are comprised of high-speed columns that include a set of labor and machinery resources for executing a continuous flow-line operation during construction of the linear portion of trunk pipelines.

The increase in the volume of construction and installing work is accompanied by an increase in the equipping of construction organizations with fixed production capital. Such an increase, especially in regard to the machinery and mechanisms used, poses severely the question of improving their utilization.

The share of construction machinery and mechanisms in the overall total of productive capital for Minneftegazstroy [Ministry of Construction of Petroleum and Gas Industry Enterprises] organizations is great. For example, it reaches 80-90 percent in the construction administrations of Severtruboprovodstroy [Trust for the Construction of Pipelines in the Northern Economic Region]. The trust's construction machinery pool is comprised basically of new machines, whose operating times have not exceeded the standard periods. An analysis of the operating efficiency of the trust's construction equipment has indicated that the basic groups of machines and mechanisms are being used intensively enough with regard to productivity. The level of equipment utilization with respect to time is high. The shiftwork coefficient for rotary excavators has risen by 4.4 percent in the past 2 years. The shiftwork coefficient for the highly productive bulldozer and pipelayer fleets also is increasing.

The introduction of new equipment for trunk pipeline construction is aimed at reducing the labor intensiveness of the work by increasing the use of mechanized labor. In this connection, the introduction of new equipment represents the replacement of one system of machines and work forces by another system of machines and a different quantity and quality of live labor. The ratio of machinery resources and work force are not identical in each of the new systems. In choosing various options for the new equipment, they should, in our opinion, be examined in terms of the replacement of live by mechanized labor, which will enable construction work to be intensified.

An analysis of the use by the production process of a particular system of equipment and the labor resources that are connected with its operations, makes this approach necessary. It is desirable to choose the type of machines and mechanisms for a high-speed column by comparing the levels of construction intensity that have been achieved by each of the options being considered.

The level of intensity of construction work can be determined by the ratio of the amount of work performed during a definite time period to the total expenditures of live labor and machinery service life. The expenditure of gross labor can be found by summing up its elements, by equating labor-resources expenditure to machinery service-life expenditure by means of a substitution coefficient (see the table). Recommended substitution coefficients (in thousands of rubles/manyear) for certain types of construction machinery for operations under Far North conditions: excavators--9.4; bulldozers of 283 kW power--14.9; and pipelayers with a load-lifting capacity of 90.7 tons--15.2.

The economic content of this coefficient lies in the fact that the labor of one worker for a year can be replaced (in standard equivalents) by the aforesaid amount of the share of the cost of the indicated type of machinery. The indicator is formed on the basis of a consideration of the average annual wage of high-speed column workers who do not work directly on the machines and mechanisms that make up the column or on equipment that should be put on the list of machinery and mechanisms that outfit a high-speed column under the new variant.

Before making the calculations for evaluating the equipment systems of the column that are being compared, a list must be made up of machines whose technical area of application corresponds to the parameters for building the linear portion of trunk pipelines. Then the area of use of the equipment is set in accordance with organizational conditions: whether it will be impossible

Calculation of Indicators of Intensiveness of Construction Operations of a High-Speed Column

Machines	Work volume per year, thousands of m <sup>3</sup>	Gross expenditures, ΣЗ, thousands of rubles	No. of workers doing manual labor	Book value of the machinery, thousands of rubles	Coefficient of substitution of live labor by embodied labor (thousands of rubles/manyyear)	Intensity of doing construction work J <sub>i</sub> , thousands of m <sup>3</sup> /thousand rubles
Bulldozer, 79.4 kW (108 hp) of power	46.2	28.79	2	6.79	11.0	1.60
Bulldozer, 283 kW (385 hp) of power	169.2	91.30	2	61.46	14.9	1.85
Pipelayer of 35 tons' lift capability	60.0	51.00	3	12.73	12.8	1.18
Pipelayer of 90.7 ton's lift capability	260.0	183.51	3	117.61	15.2	1.40

Example of a computation: for a 79.4-kW bulldozer,  $\Sigma Z = (2 \times 11) + 6.79 = 28.79$ ;  $J_i = 46.2 : 28.79 = 1.6$ .

to get the equipment on time, and, as a result of this, to execute the operations by the planned deadlines; whether deployment of the machinery over the work front that exists in high-speed columns will be hampered; and so on.

The choice of a particular equipment system should be made in stages: a comparison of systems with reference to the design for organizing the construction work; planning of the construction operations and planning for the development of the construction organizations; and a comparison of the systems during the operating process.

In the first case, the standard one, use is made of an option that calls for the use of the more widely distributed machines and will also provide for execution of mechanized operations for laying the linear portion of the pipeline on the dates that have been agreed to for introducing the job into operation or that correspond to the standard construction time.

In the second case, the new equipment is compared with the equipment that has actually been supplied to construction organizations and that has shown a high degree of reliability during operation.

The option in which the highest level of intensity of construction work is achieved for a definite operating process (or stage) should be considered the best one.

The approach set forth for choosing and using the new equipment for building trunk pipelines is in keeping with an intensification of production and a rise in its effectiveness.

COPYRIGHT: Izdatel'stvo "Nedra" "Stroitel'stvo truboprovodov", 1983

11409

CSO: 1822/132

## PIPELINE CONSTRUCTION

UDC 624.09.073-412

WAYS TO IMPROVE OUTPUT OF LARGE BOX MODULES FOR OIL, GAS INDUSTRIES DESCRIBED

Moscow STROITEL'STVO TRUBOPROVODOV in Russian No 11, Nov 83 pp 12-15

[Article by V. G. Andriyenko of Sibkomplektmontazh Association (Tyumen):  
"Increasing the Effectiveness of the Outfitted-Module Method of Construction"]

[Text] The outfitted-module method combines technico-organizational, socio-economic and politico-ideological measures that embrace all stages of construction operations (design, factory fabrication, delivery, installation and operation) and is aimed at reducing construction time and costs substantially.

Optimal mutual coordination of the indicated measures at each stage of construction supports maximum effectiveness of the outfitted-module method.

Let us look at the organizational measures that are characteristic of two of the basic stages: design, and preparation for installation.

Figure 1 shows schematically the construction stages for oil and gas facilities where outfitted modules are used. The construction process can be divided into two independent flowlines whose deadlines are coordinated. The first flowline embraces construction and installing operations (SMR's) for the below-grade work, the second is preparation for the installing work and for erection of the surface facilities.

Figure 1. Elements of a Stage of Construction Operations

1. Design
2. Preparation for the below-grade cycle
3. Execution of the below-grade cycle
4. Preparation for the surface portion of the facility
5. Erection of the BKU [outfitted-module installation]
6. Partial tune-up and turnover for operation

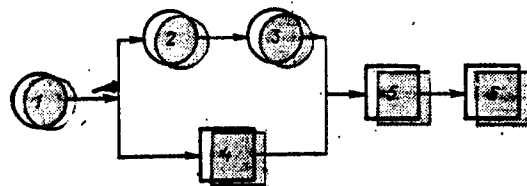

Tens of Mingazprom [Ministry of Gas Industry] and Minnefteprom [Ministry of Oil Industry] design institutes implement the design stage of construction operations. Outfitted-module installations (BKU's) for West Siberia are developed basically by SibNIPIgazstroy [Siberian Scientific-Research and Design Institute for the Construction of Gas Industry Facilities], for the country's

European portion by the SPKB [Special Design-Development Office] of Proyektneftegazspetsmontazh and the EKB [Experimental Design Office] for Reinforced Concrete. Some BKU's are created by the client's design institutes, for example, NIPibashneft' [Scientific-Research and Design Institute for the Bashkir ASSR Oil Industry]. The designs for most oil and gas facilities are of an individual nature, although there is some progress on the unification of master plans and of a number of constructional solutions. Haul roads, artesian-well units, machinery-repair and warehouse buildings and electrical-equipment units have not been unified.

Errors are often encountered in designs for oil and gas facilities. The drawings do not always observe the requirements of the GOST's [State All-Union Standards], SNiP's [Construction Norms and Regulations] and SN [Construction Norms] 202-81. The parts of the working drawings that relate to constructional architecture and to structural matters are not correlated with special parts of the design.

Working drawings for BKU's do not call for full factory preparation of the transport units. A precise division of labor in the work performed at the factory and that done at the construction site is lacking. Standard and repeatedly used designs are revised unjustifiably.

Working drawings for modules for gas facilities do not meet fully USSR Gosgortekhnadzor [State Committee for the Supervision of Industrial Work Safety and Mine Inspection] requirements.

In some cases new designs are prepared for a BKU, although standard or repeatedly used designs exist. Or the standard designs are used but without substitutions for obsolete equipment. The engineering feasibility of the three-dimensional layout and constructional solutions used are not being evaluated.

The activity of SPKB of Proyektneftegazspetsmontazh, the EKB for Reinforced Concrete and SibNIPiGazstroy is not coordinated adequately in regard to the development of standard BKU's and the structural formulation of some box modules.

A new approach to the design of oil and gas facilities is needed.

Design and budget-estimating documentation should set forth solutions that are technologically accurate in discriminating between the surface and above-surface parts of the facility and the below-grade cycle and between factory-fabrication and erection work at the construction site. This will enable the structure of the construction organization to be improved: facilities will be erected by two specialized integrated mechanized brigades. One will do the below-grade work, the other will erect the surface portion.

Models for design solutions and for the standardization and unification thereof should be established more widely. Prime design institutes should be granted the right to coordinate the development of oil and gas facilities in order to provide for a high engineering level of the designs, and they should effect integrated unification and standardization.

The evaluation of design solutions for engineering feasibility, to cover all stages of the construction sequence, will yield substantial benefit. As the machinebuilders' experience indicates, this evaluation should be made in the early stages of design, beginning with the technical task for development.

Designs for building up fields must be prepared, basically, depending upon the situation, for large box modules fully prepared at the factory that weigh up to 1,000 tons.

It is already possible now to fabricate and install a number of kinds of large box modules. For the oil industry these include cluster pump stations (KNS's), booster pump stations (DNS's), crude-oil preparation installations (UPN's), compressor stations for transporting casing-head gas (KSNG's), gaslift compressor stations (GKS's), water-intake stations (VZS's) and gas-treatment plants (GPZ's). For the gas industry these include integrated gas-treatment installations (UKPG's), STD-12500 compressor stations with electric drive for gas-transfer units and with GTN-16, GPA-Ts-6.3, GPU-10, GPA-Ts-16 and GTN-25 (KS) type gas-turbine units, and boilerhouses with two, three or four DYe-16-14GM boilers (figure 2 [not reproduced here]).

The general constructional elements for oil and gas facilities built up from large box modules now take existing experience and prospects for progress in construction work into consideration. These elements determine the following types of approach.

In the first type, the equipment is disposed in two tiers, both inside the pontoon and on the pontoon itself. Thus the module becomes a two-story structure. Such modules are delivered under a combined scheme: first by water, then by dry land by skidding or by means of transport facilities. It is installed on the foundation basically by dragging. Such modules include KNS's, DNS's and so on.

The second type of module is built the same way, but the pontoon is made from noncorroding metals or with special protection against corrosion. The modules are delivered only by water, or by water and a small strip of dry land. They are set up on water in specially excavated foundation pits and remain afloat during the entire period of operation. Among such modules are water-intake installations.

The third type of module is one-story, and the equipment is deployed just on the pontoon. The inner portion of the pontoon can be used for storing fuels and lubricants and other materials. Such modules are installed and operated on dry land. These are a series of UKPG modules.

Modules on so-called floating foundations--pontoons--(the fourth type) do not differ in design formulation from the third type, but installation on the foundation has its peculiarities. Canals and foundation pits are excavated to the installing site from the river or channel. Footings are built in the foundation pits, and, by regulating the water level along the canals, the modules are brought in and placed on the footings. It is planned to erect gas-treatment plants from modules with unit weights of up to 2,000 tons by this method. They can be operated on either dry land or water.



The fifth type is a module without a pontoon, on rigid nonfloating footings. They are transported by several methods. One of them is delivery on a special packaged installation intended for repeat use, which, by means of an air cushion, can float on water or be moved over dry land, and it is installed on footings. With other methods of delivery, transport facilities based upon the use of rubber-tired or crawler dollies are employed.

It has now become necessary to develop model three-dimensional layout and constructional solutions for oil and gas facilities in an outfitted-module version and, based thereon, to establish a set of standard USSR Gosplan and USSR Gosstandart [State Committee on Standardization] documents. These papers should include: new norms for the design of oil and gas facilities in outfitted-module versions, including those made of large box modules; a methodology for integrated unification and standardization; a methodology for evaluating facilities in the outfitted-module version, based upon engineering feasibility; and so on.

The Stage of Preparation for Construction and Installing Work is an integrated process. It includes the following elements: organizational planning, design, the technological factor, the supplying of materials and equipment, factory manufacture of outfitted-module installations, the delivery thereof, preparation for construction and installing work, and economic preparation (figure 3).

Figure 3. Elements of the Stage of Preparation for SMR [Construction and Installing Operations]

- 4.1. Organizational planning
- 4.2. Design development
- 4.3. Technological
- 4.4. Supply of materials and equipment
- 4.5. Factory manufacture
- 4.6. Preparation for transport
- 4.7. Delivery of the BKU (outfitted-module installation)
- 4.8. Preparation for SMR
- 4.9. Economic preparation

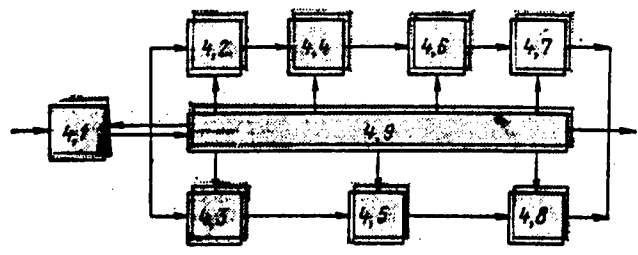

Substantial reserves for increasing effectiveness in the construction of BKU's, aside from transferring some construction and installing work from the construction site to factories, are to be found in realization of the basic principles of organizing machinebuilding output at BKU plants. These principles include: differentiation--apportionment of the process for manufacturing like BKU's among various sections and departments; combining--the amalgamation of all or a portion of the processes of various natures for fabricating a certain type of BKU within one section or department; concentration--the centralization of operations for fabricating technologically similar BKU's at various workplaces, sections, departments or production enterprises; and standardization--the use of uniform specifications for fabrication that will allow series output of a product.

Targets of standardization should include: finished BKU's, materials, parts and assembly units of modules; technological processes and supply; the rules and norms for performing design and calculating operations; and organizational forms for production.

Among the principles for organizing machinebuilding production are specialization, universalization, continuity, smoothness, parallelity, directness of flow, and use of automation. The principle of insuring reliability is to preserve the efficiency of a production system over a prescribed time period and under certain operating conditions, with fulfillment of the program for producing BKU's by the prescribed date and with proper quality.

Some of the indicated principles have been realized at plants of the production-support base of Sibkomplektmontazh Association, but some still have not been realized because of the lack of precise interaction among clients, general contractors and the associations, late issuance of the designated plan, lateness in being outfitted with equipment, and delays in the transmittal of design and budget-estimating documents. The basis for formulating designated plans for plants for BKU's and KMEZBU's are the certified orders. When formulating them, general contractors do not, as a rule, indicate the composition of the facilities or the assigned code numbers of the design documentation.

Thus, Kazymgazpromstroy [Kazym Trust for the Construction of Gas-Industry Facilities] did not meet the requirements for the certified orders that were made up last year for the Sosnovskaya, Verkhnekazym'skaya, Bobrovskaya, Oktyabr'skaya and other compressor stations. Poor quality certified orders were sent by Tyumengazpromstroy [Tyumen Trust for the Construction of Gas Industry Facilities] for KS-1 [Compressor Station No 1] and KS-4 of the Samotlor Field, and Kazymneftegazstroy [Kazym Trust for the Construction of Oil and Gas Industry Facilities] did not indicate any coding at all for a whole list of facilities. Negligent preparation of such important papers as certified orders is characteristic also for trusts of Glavtyumenneftegazstroy [Main Administration for the Construction of Oil and Gas Industry Facilities in Tyumen Oblast], Glavsibtruboprovodstroy [Main Administration for Pipeline Construction in Siberia] and Glavurengoygazstroy [Main Administration for the Construction of Gas Industry Facilities in Urengoy].

General contractors should formulate certified orders correctly. Even if, at the time they are prepared, certain design and estimating documentation is lacking, the general contractor can always ascertain the composition of the facilities through the client and the general designers and determine the minimum facilities that are due for early startup.

Deadlines for sending design and budget-estimating papers often are not met, and the client often does not deliver equipment to the plants on time.

The client--Tyumengazprom [Tyumen Gas Industry Association]--sends equipment to the BKU plant not by module but in bulk. The plant's workers have to spend much time breaking it down and sorting it out by module.

Sometimes, when delivery deadlines for certain equipment are not met, the client sends this equipment not to the plant but to the installing site. Diesel motors for modular electric-power plants at Urengoy-Petrovsk gas pipeline KS's were sent to the construction site. Doing so greatly increased labor expenditures for installing them.

As a result of such interruptions, the plants do not operate smoothly, much worktime is lost, and quality in the erection of box modules is reduced.

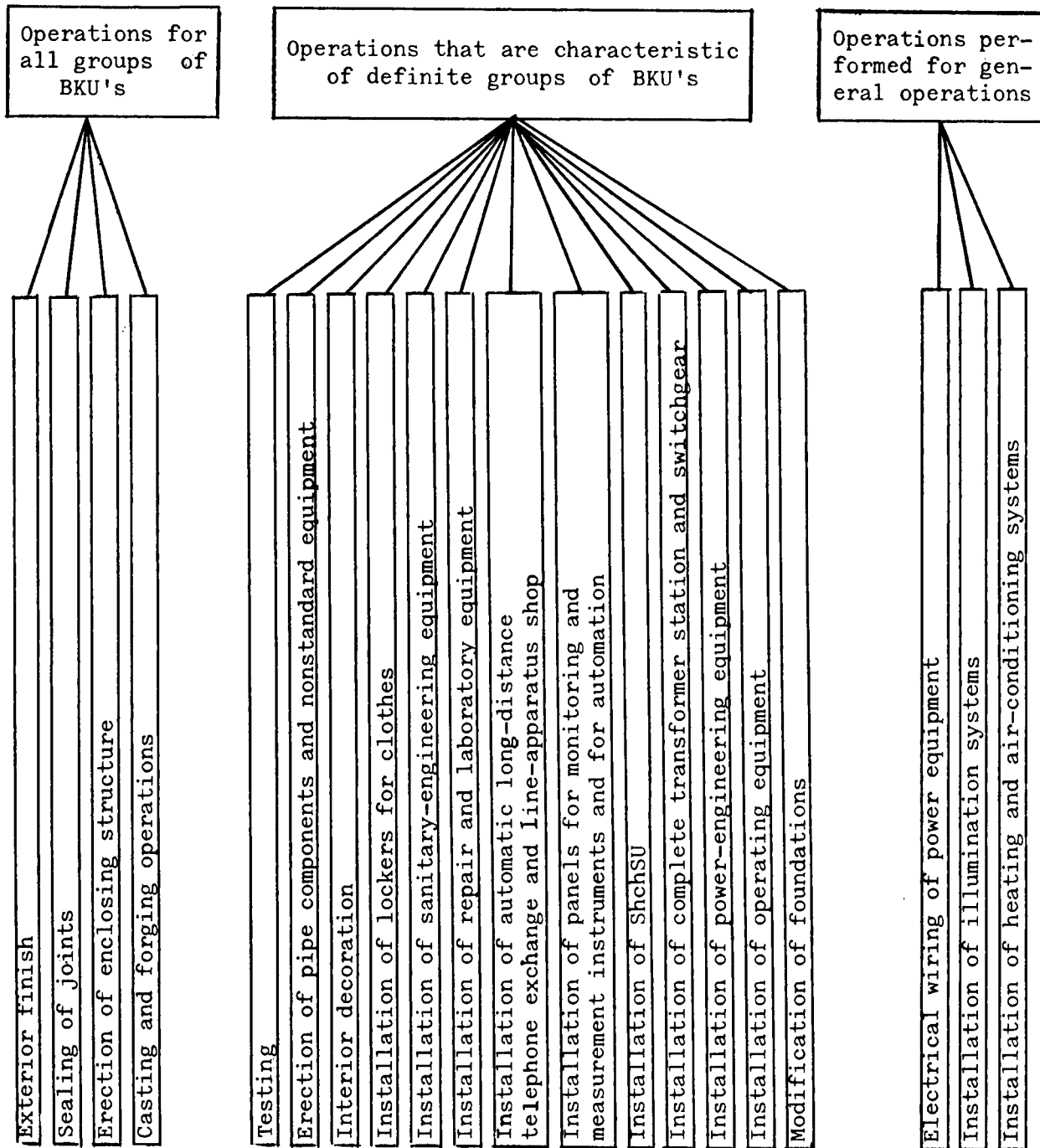

Figure 4. Classification of Types of Operations During the Fabrication of BKU's (Outfitted-Module Installations]

In order to increase labor productivity and improve organization of the assembly of BKU's on mechanized assembly lines, the association has made up a classification of the basic types of operations (Figure 4). However, without integrated unification and standardization, which should cover all stages of the construction sequence, primarily the design stage, the association's plants will operate in just an individual-item production mode, or, in the best case--for some parts and components--in a short-series production mode. And this means that it will be impossible to use special tooling and nonstandardized equipment or to increase labor productivity.

It is necessary to provide for the timely formulation of a plan for factory fabrication, for which the general contractors should correctly formulate certified orders, paying special attention to decoding for the components of the facilities and to indicating the codes for the design and estimating papers.

BKU's must be manufactured only on mechanized assembly lines that are supplied with the required tooling and nonstandard equipment. The associations should create a tool support service and a pool of all-purpose machine-tool equipment for it.

A program must be set up for realizing the basic principles of machinebuilding output, which are aimed at maximum labor productivity and improvement of output quality.

COPYRIGHT: Izdatel'stvo "Nedra" "Stroitel'stvo truboprovodov", 1983

11409

CSO: 1822/133

## PIPELINE CONSTRUCTION

UDC 624.057.4+658.5

### ERECTOR OF PIPELINE COMPRESSOR, PUMP STATIONS COMPLAINS ABOUT POOR SUPPORT

Moscow STROITEL'STVO TRUBOPROVODOV in Russian No 11, Nov 83 pp 15-16

[Article by Ye. S. Kvasha of Yuzhkomplektmontazh Trust (Novocherkassk): "Ways to Improve the Activity of the Mobile Trust"]

[Text] Yuzhkomplektmontazh Trust erects compressor stations (KS's) and pump stations (NS's) in the outfitted-module version in areas of the North Caucasus. Its composition includes General Construction Administration No 3 (Novocherkassk); Installing Administration No 4 (Groznyy); Installing Administration No 1 (Bataysk); Administration for Mechanization for the Transporting of Outfitted-Module Installations (BKU's) and of Construction Machinery; a specialized administration for putting together and outfitting sections that will manufacture BKU's; a production-operations outfitting administration; and a motor pool.

During 1981-1982 the trust assembled the Polyanskaya, Moskovo and Izberbash compressor stations, the Nikulino, Uspenskaya and Progress pump stations and more than 278 kilometers of oil and gas pipelines, and it introduced 11,795 square meters of housing space for oil and gas industry workers, including 338 square meters for the trust's workers.

In 1982 the trust, with its own efforts, provided for fulfillment of the plan by 103 percent and increased SMR [construction and installing operations] by 2,455,000 rubles' worth (13 percent of the 1981 level), met the task for labor productivity by 102.8 percent, and reduced the prime cost of operations by 0.2 percent.

The trust's activity embraces, on the average, 12 geographical regions of the country, including Voroshilovgrad, Rostov and Volgograd Oblasts, Krasnodarskiy and Stavropolskiy Krays, the Azerbaijan SSR and the Dagestan and Checheno-Ingush ASSR's.

In accordance with the existing regulation on mobile trusts, Yuzhkomplektmontazh does basically installing work under subcontracting agreements. Some general construction work performed under general contract comprises a certain share.

The trust, as the leading installing subunit for the construction of KS's and NPS's [oil-pumping stations], involves a number of organizations in the

installation of KIPiA [monitoring and measuring instruments and automation], sanitary-engineering equipment, electrical equipment, and so on. The small amounts of such work and the territorial dispersion of the jobs provokes a certain organizational complexity.

The trust needs an expansion of production space for repairing equipment and for making box modules and components for KS's and NPS's, and it requires storage premises, where it would be able to store box modules and to install sanitary-engineering equipment, electrical equipment and KIPiA in them. The necessary number of transport units for hauling box modules has not been provided.

It is sound practice for the trust to have a special design bureau which should, prior to the manufacture of box modules, send to the manufacturing enterprise, the SU [construction administration] and the SKBU the following design documentation: drawings of general views of the facilities and the modules; the operational, sanitary-engineering and electrical schemes; drawings of components and parts; a draft of specifications for the manufacture, acceptance, preparation for shipment and transportation of BKU's; and the engineering description certificate for the modules.

The creation of such a design bureau will yield substantial benefit.

In considering the specifics of Yuzhkomplektmontazh Trust, the general contractor, while concluding the agreement with the client, should, in order to prepare for production, call for the client's design organizations to transmit the master plans for the facilities, the consolidated plans for the utility and service lines, lists of the modules used, and--for inclusion in the design of new modules--the outfitting design documentation, directly to the chief installing organization by the prescribed deadlines. Late transmittal of such documentation (such cases are not rare) complicates performance of the work and delays the dates of their fulfillment.

It is especially important to provide budget-estimated documentation for outfitted-module construction that employs box modules in which KIPiA, sanitary-engineering equipment and electrical apparatus are installed.

The client's design institutes, when including transport costs in the budget-estimated cost during the elaboration thereof, do not always perform good-quality costing. The budget estimate omits the cost for installation at the site and does not give the cost by type of work. The use of such costing is complicated.

The frequent replacement of engineering documentation for individual box modules adversely affects profitability of the operation.

Development of the outfitted-module method of construction is fully linked up with improvement in organizational forms for control: by the creation of standard structures for the administrative staff; and by the use of more flexible types thereof that will meet the specifics of the construction of the surface facilities. Use of the three-level system of contractual relationships reduces operating effectiveness, hampers the coordination thereof, and

degrades the indicators of construction-organization activity in regard to introducing facilities into operation and turning over construction commodity output.

The poorly arranged supplying of materials and equipment for construction jobs provokes definite difficulties. It causes idle time for installers, machinery and mechanisms and the reassignment of workers to the fabrication of pipeline elements--elbows, T-branches and adapters of all kinds and sizes--which leads to an increase in their cost and is reflected negatively in the prime production cost and profitability of the organizations. It is necessary to unify and organize centralized procurement of the indicated parts and components at the factory, and shipments must be executed in accordance with the organizations' orders.

Major attention should be paid to the supplying of materials and equipment for jobs on which there is a backlog of completed work.

Solution of the indicated questions will raise the effectiveness of the mobile trust.

COPYRIGHT: Izdatel'stvo "Nedra" "Stroitel'stvo truboprovodov", 1983

11409

CSO: 1822/133

## PIPELINE CONSTRUCTION

UDC 621.643.002.2/551.481.2

### WAYS OF YEAR-ROUND PIPELINE BUILDING IN SWAMPY AREAS EXPLAINED

Moscow STROITEL'STVO TRUBOPROVODOV in Russian No 11, Nov 83 pp 17-19

[Article by N. P. Vasil'yev of VNIIST [All-Union Scientific-Research Institute for the Construction of Trunk Pipelines]: "Ways of Supporting Year-Round Pipeline Construction on Swampy Terrain"]

[Text] The most important tasks facing Minneftegazstroy [Ministry of Construction of Petroleum and Gas Industry Enterprises] during the 11th Five-Year Plan are acceleration of the pace of pipeline construction and elimination of the seasonality of work on the right-of-way.

VNIIST has, jointly with the main operating administrations and scientific-research and design-development organizations of the industry and of other ministries and agencies, developed and introduced new design-development and operational solutions for the effective construction of trunk pipelines in the summer and winter periods, and a new form for organizing flowline-type construction of pipelines by integrated flowline operations groups has been widely applied.

In the summer each year, Minneftegazstroy construction and installing subunits erect about 300 kilometers of trunk pipelines in flooded and swampy areas.

Basically, construction work on the pipelines proper continues to be seasonal in nature in swampy regions.

Integrated solution of the problem of year-round construction in swampy places depends primarily upon the adoption of optimal design solutions, the use of new materials and structure, a rise in the mechanization level, and the development and introduction of improved technology and progressive ways of organizing the work.

Just when is year-round pipeline construction in swampy places effective?

Research has indicated that year-round pipelinebuilding can be beneficial when the total length of the swampy sections does not exceed the length of the relatively dry sections.

An analysis of design solutions and of pipeline-construction experience gained during the 10th and 11th Five-Year Plans allows one to conclude that all



regions have enough relatively dry sections to allow work to be organized there during the summer.

The maximum indicator of economic effectiveness corresponds to the optimal number of flowline groups for the construction of pipeline right-of-way facilities (LOSP's), and their productivity is 1.0-1.5 kilometers per shift. Economic effectiveness can be increased and overall construction time reduced by cutting organizational idle time, using progressive technology and improving design solutions.

The approach to solving problems of year-round pipeline construction in various regions should be different, depending upon the swampiness ratio, the characteristics of the peat deposits and the road conditions.

The principal, most typical parts of the country for which the ratio of swamps, the nature of the peat deposits, and the road conditions would be encountered with the greatest consistency are: the West-Siberian region; the North European region, which embraces the Komi ASSR and Arkhangelsk and Vologda Oblasts; the Central-European region, which includes Perm, Gorkiy, Vladimir, Ryazan, Moscow, Tula, Kalinin and Smolensk Oblasts and the Udmurt, Tatar and Chuvash ASSR's; and the Belorussian region, which covers Vitebsk, Minsk and Brest Oblasts.

In order to determine the swampiness of the indicated regions, an analysis was made of the designs of 8 trunk pipelines which totaled about 10,000 kilometers in length and which were divided, as a function of the specific conditions, into segments 80-120 kilometers long with relatively homogenous indicators.

The numerical values for the main regional indicators and the ranges of their variations, which will allow evaluation of the constructions conditions for newly designed pipelines that will cross one or several of the regions, are shown in the table.

Main Indicators for Swampiness by Region

Indicator	Region			
	West Siberian	North European	Central European, including the Meshcherskaya lowland	Belorussian
Swampiness of the region, percent.....	<u>27</u> 12 - 52	<u>16</u> 7 - 40	<u>5(82)</u> 0.4 - 27	<u>9</u> 0.6 - 33
No. of swamps per 100 km..	<u>42</u> 46 - 91	<u>52</u> 20 - 81	<u>17(42)</u> 2 - 36	<u>20</u> 1.0 - 37
Length of relatively dry sections:				
Kilometers.....	<u>14</u> 5 - 35	<u>22</u> 10 - 46	<u>170(6)</u> 18 - 300	<u>56</u> 11 - 262
Percent.....	<u>41</u> 0 - 58	<u>49</u> 35 - 89	<u>96(10)</u> 76 - 100	<u>88</u> 70 - 100

Note: Limiting values are given below the line.

A prognostic evaluation of the conditions will enable the degree of effectiveness of year-round construction of a given pipeline and the seasonality and approximate dates of completion of the various segments thereof to be determined, a preliminary calendar schedule for pipeline construction to be prepared, the dates and amounts of deliveries of pipe and of other materials for the various segments of the line to be planned, and a rough transportation scheme to be worked out.

Let us examine the main guidelines that will provide for year-round pipeline construction in the various regions.

West Siberia and the North European Regions. The problem of year-round construction here can be solved basically by organizing summer line work on the relatively dry portions of the right-of-way or by choosing optimal construction periods.

The task of choosing optimal periods for erecting pipelines in swampy areas comes down to determining the sequence of erecting the segments, taking into consideration the time for building up the flowline group and its capacity, the production scheme, and the characteristics of the right-of-way. It is one of those tasks of the theory of calendar-planning schedules, and it has multiple criteria and a multitude of unrelated solutions.

The choice of the criterion of optimality depends upon the specific conditions. In one case, it is a reduction in construction time, in another it is a minimization of equated expenditures.

In considering that the most rapid completion of construction of trunk gas pipelines is at present the industry's main mission, reduction in the time taken to erect them is adopted as the criterion of optimality.

In the tasks of ordering priorities, the constraints are formulated as the demand for the use of resources, observance of the prescribed budgeted cost, and maximum yield on capital of the construction organization.

In posing the task of ordering priorities, the following should be substantiated: the characteristics of the pipeline right of way (diameter, number and length of flooded sections and of swamps of the various types); the degree to which construction subunits have been mechanized; the operating schemes for doing the work on the segments of various categories in the winter and summer and the prime cost and the pace of the operations that correspond to the operating schemes; the redeployment distances along the route; and the prescribed deadlines.

In practice, some of these parameters definitely lead to deviations from both the planned and the actual level of construction and installation performance. Their effect on construction progress can be of a rather persistent nature.

The combined effect of all the factors is reflected in the actual distribution of the volume and pace of operations over the year. Thus, the statistical data for a number of preceding years can be used as baseline data. An analysis of the data will enable determination of the functional dependence

of the distribution of the annual program for the work of construction and installing organizations on time, and determination of the annual work volume by separate period of the year, taking seasonal fluctuations into account.

West Siberia and the North European and Central European Regions. Special attention should be paid here during pipeline construction to prolongation of the winter construction season through earlier freeze-up of swamps and a lengthening of the period for movement of transport equipment and erecting mechanisms on a frozen base.

Since the main factor that prevents natural freezing of the soil is the snow cover, complete removal thereof in early winter should be considered to be the most effective measure. In this case, the construction season in the Middle Ob regions can begin 1-1.5 months earlier. In order to remove the snow cover from the swampy surfaces it is desirable to use the walking swamp traveler that is based upon the MTZ-80 tractor that the Kalinin Polytechnical Institute developed jointly with VNIIST.

Central-European and Belorussian Regions. Pipelines can be built over swamps during the summer from temporary operating roads made of logs or of off-the-shelf materials, by the floating or towing method. VNIIST has developed a technology for building pipelines by using modern technical solutions: passageways made of rolled materials, temporary roads built of off-the-shelf materials or temporary roads of the herringbone type. The use of effective mechanization resources was called for: gantry pipelayers, rotary pipe-burying equipment or devices for shredding peat deposits, scraper-type backfillers, and other items. The technology that was developed provides for a sharp rise in the pace of line operations in the summer.

This technology includes the following operations: a temporary three-lane or two-lane road is erected from off-the-shelf materials on the swamp. The topping of the passageway is made of preassembled material, it incorporates a high degree of industrialization and provides for a rapid pace and low labor intensiveness of erection. Pipes, single or welded, are conveyed along the middle lane of the passageway, and they are spread out on the construction strip by means of special cranes, whose loads are uniformly distributed on the two edges of the strip.

The erection and welding of the pipes or assembled pipe sections into the strand by the flowline-group method or the separate flowline method are performed on one lane of the passageway with the use of cranes, whose loads are distributed uniformly on the two other strips. The insulation coating is applied to the pipeline. Simultaneously with execution of the insulating operations, the pipeline is moved to the centerline of the future ditch.

Laying the pipeline into the designed position is performed by undermining it or caving it into the broken-up peat deposit.

Belt-type reinforced-concrete hold-down weights or anchoring devices that are installed on the pipeline, which has previously been placed in the water and submerged by means of off-the-shelf pipeline weights, can be used in securing the pipeline at the designed grade level. Backfilling is done by scraper-type backfillers, which are moved along the same lanes of the passageway.

Introduction of the indicated technology requires the development and manufacture of a number of construction machines and mechanisms.

Pipelines can be built in the swamps during the summer also without the apparatus for a special passageway by using stepping swamp travelers. In so doing, the work methods applied with floating or towing of the pipeline that have already been widely adopted in pipeline-construction practice should be used to the maximum.

The method of the successive buildup of welded pipelengths that VNIIST has developed and which requires only the building of a temporary haul road for redeploying the flowline group and for partial transporting of pipe and hold-down weights will find application when erecting pipelines at crossings over swamps.

New structure for hold-down weights and anchoring devices have been created for ballasting and for securing pipelines that are laid in swamps.

Methods have been developed for digging ditches in deep swamps in the summer by ripping up (or grinding up) the peat deposits. The possibility of forced freezing of local swamps in the summer is being studied.

The use of pipe with factory applied insulation, especially in the summer, enables the work pace in swamps to be greatly increased.

The indicated developments will enable the industry to undertake large-scale experiments on the year-round construction of cross-country pipelines and of pipelines within the petroleum fields of various parts of the country, during which special attention should be paid to perfecting new operating schemes for summer construction, improving industrially produced structure for temporary roads, and creating lightweight mobile transport equipment with a specific ground pressure of no more than 0.01-0.15 MPa, as well as methods for excavating ditches in swamps that are made up of decomposed peat.

For winter operations, questions of providing for the longitudinal stability of pipelines that are laid on soils of poor load-bearing capability and of creating special technology that will enable the performance of operations at ambient air temperatures down to -30 to -40 degrees C and high operational reliability of the trunk pipeline structures being erected acquire the greatest significance.

COPYRIGHT: Izdatel'stvo "Nedra" "Stroitel'stvo truboprovodov", 1983

11409

CSO: 1822/130

## RELATED EQUIPMENT

UDC 624.09.073-412

### PREFABRICATED BLOCK-UNIT ROOMS FROM ALMETYEVSJK

Moscow STROITEL'STVO TRUBOPROVODOV in Russian No 11, Nov 83 pp 16-17

[Article by V. A. Kulik, SU SKBU, Tatkomplektmontazh Trust, Almetyevsjk: "Improving BKU Designs"]

[Text] The specialized block-unit assembly and set-packaging administration (SU SKBU) of the Tatkomplektmontazh Trust is manufacturing block-unit devices (BKU). The planning-design buro and assembly shop are searching intensively for ways of improving block-unit designs and the methods of transporting them and installing them at the construction site.

The first stage of introducing the complete block-set method was the manufacture of a prefabricated base box (OB) and unitized box (UB), which were developed by the reinforced concrete experimental design buro of the Ministry of Construction of Petroleum and Gas Industry Enterprises.

Working from experience already accumulated in the manufacture and assembly of block boxes, workers at the SU SKBU PKB [planning-design buro] made in the planning-design documentation substantial changes aimed at raising the level of BKU factory readiness, broadening opportunities for using any given layout resolution, improving unit adaptability to transport, and lowering labor expenditures at the installation site.

An articulated version of the prefabricated blocks was manufactured using blueprints developed by PKB specialists. The articulated block-boxes have advantages over prefabricated blocks in that they can be transported folded. Two such block-boxes fit onto a railroad flatcar.

The block-boxes are opened up using a special crossbeam at the construction site. The butt frame assumes the designed position and is welded to the foundation.

Another advantage of the articulated block-box over prefabricateds is the greater room height which is now possible: 3.6 meters, instead of the 3.15 meters previously possible.

The prefabricated room unit is designed as a three-dimensional frame on which panels are hung. The load-bearing elements of the unit roof are quite strong, so as to eliminate the need for intermediate supports the entire length of a 12-

meter span. When necessary, a suspended ceiling is built into the room. The length, width and cross-section of the unit in transport are within maximum railroad dimensions.

The units are laid out by length and by short side. Buildings can be single-side, two-span, and of practically unlimited length. Component metals-intensive-ness has been lowered by 12 percent and manufacturing labor-intensive-ness is 10 percent less.

Variable-height units are widely used in installing production and administrative - personal-services premises, as well in manufacturing block-boxes with technological equipment and block-boxes designed for service and monitoring systems.

The power component of such units includes a steel frame and heated foundation. The enclosure components are APS-1 and APS-6 panels and roof panels. The wall panel and partition distributions are chosen depending on technological and operating requirements.

One feature of the BIV-12 block-box is a telescopic device consisting of outside and inside pedestals. When the inside pedestal, on which the unit roof is installed, is moved out, the roof is raised from transport position into working position. In transit, the unit is 2.65 meters high; it is 3.2 to 3.8 meters high after installation on the foundation. This type of block-box has a number of advantages over the articulated type, primary among which is the possibility of installing technological equipment under assembly-shop conditions, thanks to which the level of factor readiness of the block-boxes with movable pedestals is significantly higher than for articulated units.

Much attention is currently being paid to further raising the organizational-technical level of construction, to introducing better methods of production organization.

The administration has developed and mastered the release of complete boiler-unit sets consisting of one unitized UB-12 block-box. These have a high level of factory readiness. They can be delivered to the site by trailer truck, rail flatcar or ship. Site work has been reduced to a minimum.

Block-panels are used instead of firebrick for boiler-unit insulation. The insulation is ensured by circulating water inside the block-panels, which are in the form of a water jacket. This new insulation method considerably raises the level of work industrialization.

At the assembly shop, installation of the block-box is divided into a number of sequential operations. The foundation is installed first. Then the floors are installed, then the frame, equipment, wall panels, roof panels and ceilings (in the case of an administrative or personal-services unit). Brigades of installers led by P. A. Zoteyev and A. V. Sharonov are working successfully on the shop's two flow lines.

Each operation employs a link of four workers divided into two "twosomes." This same division of labor is also most appropriate in the brigades, since the amount

and nature of the processes being performed at each sector require no more than two workers, given the simultaneous installation of block-boxes. One is generally more experienced than his partner. The workers have mastered two or three related occupations. Full interchangeability of brigade members is a primary feature of labor organization in these collectives, eliminating losses of working time and increasing the responsibility of each worker. The brigades work under the cost-accounting method.

Further improvement in BKU manufacturing will require renovation of the assembly shop, updating of the equipment in use in it, and also the complete and prompt delivery by clients of equipment needed right to the base.

COPYRIGHT: Izdatel'stvo "Nedra" "Stroitel'stvo truboprovodov", 1983

11052

CSO: 1822/129

## ENERGY CONSERVATION

### KAZAKH COAL INDUSTRY NEEDS INCREASED EFFICIENCY, CLEAR REGULATIONS

Alma-Ata KAZAKHSTANSKAYA PRAVDA in Russian 15 Nov 83 p 4

[Article by E. Krivobokov, correspondent for KAZAKHSTANSKAYA PRAVDA in the column "How You Are Served": "Coal Allotted According to Unwritten Rules at the Alma-Ata City Fuel Center"]

[Text] The damp grey November sky kept sprinkling fine, almost invisible, rain. However, people were clustering at the gate of the fuel center when we drove up, in spite of the bad weather. What brought them here? Since 1973, Almaatrans-agentstvo [not further identified] has been practicing delivering fuel without the participation of the customer. The client pays for the cost of the coal and transporting, and then on a fixed day, he calmly waits at home for the truck with coal.

However, many residents of Alma-Ata have recently preferred not to wait for an order, but go to the fuel center (approximately one out of five of the 50,000 customers per year). G. Unzhakov, a veteran of the Great Patriotic War who lives on Kubeyev Street, has been watching at the center's gate for his order since 7:30 in the morning. A. Yermilova, an employee of the Second Motor Vehicle Depot, asked for time off from work this morning and came here. V. Shevel', an invalid of the Great Patriotic War, and others came to the fuel center long before it opened.

"If you don't see for yourself what coal is loaded," explains G. Unzhakov, "they will bring you only dust, which will not do at all. So it is better to be cold here for one day than to sit all winter in a cold hut afterwards...."

The idea of being personally present during the loading of fuel becomes clear when one becomes familiar with the quality of the coal entering Alma-Ata and the procedure for selling it. Of the 262,000 tons allocated for the current year, only 120,000 are a high-quality product. The rest is substandard coal dust, which is more convenient and profitable to burn in specially equipped municipal or industrial boiler furnaces rather than in stoves. And both types of coal are stored together in one place and sold at one price (which is very strange). There are no instructions regulating sale according to grades. If the client wants to buy a better coal (an entirely legitimate desire), he is forced to look for unofficial and illegal, by the way, contacts with those on whom this depends. And how is it possible to win the favor of a truck driver



or a loading machine operator? It is not hard to guess. Such a selling practice creates the basis for abuses and a different kind of machinations. It gives rise to numerous criticisms of the coal's quality, because some customers get high-quality fuel, while others (most often those who wait for their order at home) get only coal dust. It is no mere chance that many clients have recently been refusing to accept coal ordered which turns out to have an extra expense for transportation. A question comes to mind: Why not organize separate storage and the sale of fuel according to grades, which would make it possible to purify considerably the unhealthy atmosphere around the fuel center and to make a really convenient new form of service: fuel delivery to the public without the participation of the customer? The client would know beforehand that he will receive so much fuel of a certain grade and so much of another, in accordance with the funds allocated to Alma-Ata. Then he would really not have to go to the center to "struggle" for high-quality coal. We put that question to both the employees of the city fuel center and the employees of the Kazakh Main Fuel Supply Administration and received an answer that was not very comforting: It is possible to store coal according to grades, of course (a new siding is even being built for that purpose now, and the concrete is being laid for a new platform), but it is impossible to regulate the sale according to grades; each person has the right to acquire the kind of coal he wants, and no one can deny the customer this right.

Formally, yes [this is possible]. In practice, this [problem] is encountered often. When we sell high-quality fuel only to some customers, by doing this we are actually at the same time denying it to others. So it is better, knowing the limits beforehand, to allocate it fairly. At the same time, it is necessary to establish privileges for war veterans and to allocate only high-quality coal to them. Under the unwritten selling rules existing at the fuel center, in reality veterans do not have even the slightest privileges. And what is more, they find themselves in the worst situation, because they have fewer opportunities and strength to "struggle" for better coal. Here is an example. For half a day on 4 November, Aleksandra Semenovna, the wife of Aleksey Dement'yevich Yermilov, a veteran of the Great Patriotic War, was getting soaked at the fuel center gate. Driver S. Losev (truck number 99-29ATS) got her request for service. He did not go to the veteran on the first run. When loaded the second time, he decided to bring fuel for himself--the fuel appeared to be quite good. But Aleksandra Semenovna begged and then complained to the driver to bring some to her--all in vain.

"I'll deliver to you according to the order during the day," he stated.

And so Losev drove home. The high-quality coal on the platform ran out by noon, and the woman stayed to wait for the next trainload. We don't know if she got it.

Complaints are also coming to the editorial office of KAZAKHSTANSKAYA PRAVDA about the bad work of truck drivers who accept orders to transport the fuel but do not have time to carry them out. Here is quite a typical story.

V. Serbin, a worker at the Plant imeni Kirov, ordered coal for Tuesday, 18 October. He asked for time off from work and waited for an entire day; the fuel was not delivered. V. Serbin filled out a new form for the 28th. He asked

for time off from work again. The story repeated itself. He did not get any coal on 3 November either. We met V. Serbin the next day in the fuel center's dispatcher office, when taking leave this time, he came to look into the reasons for the procrastination. And Serbin is just one of scores of such customers.

V. Usov, deputy chief of the Almaatatransagentstvo Motor Vehicle Combine, whose trucks carry out the transporting of the loads for the population, confirms this.

"We do have debts. By the middle of October, there were more than 700 unfilled orders accumulated. By 4 November, this figure was reduced to 250 and continues to decrease. We have now increased the number of trucks for hauling coal, and we intend to completely eliminate the obligations within the next few days."

What is the reason for the interruptions in the transportation conveyers?

Fuel is like a sled, which must be prepared in summer. In reality, the majority of the population, as shown in practice, puts off worrying about it until the last minute, when the cold is nigh, as they say, and there is already nowhere to retreat.

"We are fluctuating on waves of an unpredictable ebb and flow of purchasing demand," says V. Usov. "In April, May, and June, when about five to six trucks are working at transporting coal, there are no orders, but in the autumn, ten times more trucks are needed. We recently travelled to Rostov-on-Don for experience. There the transport workers in their turn also experienced the same difficulties. Therefore, they began long ago to regulate the selling of coal in Rostov. And when the fuel booklets are distributed, the client is shown at once the number of his order and the delivery time. It is convenient for the population and convenient for the transportation agency. We asked the city fuel center in the Kazakh Main Fuel Supply Administration to establish, once the fuel booklets are already issued, at least the sequence for the city rayons to take the allotments. But the supply center workers do not want to listen to our suggestions. Someone else's difficulties do not especially concern them.

But in fact, the question here does not concern only the interests of the transportation agency. The problem of efficient use of transportation is also a state problem. It is impossible to justify a situation in which the maximum fuel delivery coincides with the peak of the seasonal agricultural work by departmental excuses.

"It is possible to work out a schedule for delivering fuel to the population so that a large part of the agency's coal would be hauled in the spring and summer," says V. Shilkin, chief of Almaatatransagentstvo. "Then in autumn, without harming the service, we will be able to send the trucks more often to transport bread to the virgin land, for example. Such a schedule would also help the residents of the capital reduce the time input (sometimes work time!) considerably for the troubles connected with the purchase of fuel."

...Perhaps the described scenes at the gate of the fuel center which the author of the correspondence had occasion to observe will nevertheless convince the workers of the Kazakh Main Fuel Supply Administration that the existing procedure

for supplying fuel to the residents is very imperfect and requires urgent and substantial correction. Both the material and moral costs of selling fuel according to unwritten rules are already too great.

When this material had already been sent to the press, the editorial office received a letter from Tselinograd which indicates that the deficiency in the procedure for selling fuel is not just a problem in Alma-Ata. This is what S. Ivantsov, A. Klimenko, and V. Martynyuk, invalids of the Great Patriotic War, write.

"It is hard to describe what is happening at our Tselinograd Fuel Center. We have already been waiting in line to obtain coal for several weeks. We go there like going to work. We are told that there are not enough trucks to transport coal. But we see how the drivers are 'catching' clients even on the road and deciding themselves to whom and when to transport the fuel. It is clear that there is a selfish motive for this. But the queue--let it wait. It is impossible to get to see the director. For he is the director, and the chief of the storage facility, and the weigher. From morning to 10:30 he's out on break. And then he distributes fuel. He has no time. We tried to state our complaint to the chief engineer, who referred us to the director: 'I haven't been working here long; I still don't know anything...'

"The fuel center's work schedule is also very inconvenient for the clients."

As we see, the situation is the same as at the Alma-Ata Fuel Center: There is coal, coal in abundance, but it is impossible to purchase it. It is not an entirely normal situation, to say the least, which requires immediate measures on the part of the Alma-Ata Main Fuel Supply Administration obviously on the scale of the entire republic.

12478

CSO: 1822/123

## ENERGY CONSERVATION

### METHANE USED TO HEAT MINING COMPLEXES AT DONETSKUGOL'

Kiev PRAVDA UKRAINY in Russian 16 Nov 83 p 2

[Article by V. Novoselov: "Methane Serves the Miners: The Economy Must Be Economical"]

[Text] The deeper mines become, the more we find dangerously explosive methane in coal beds. It is usually removed in this way: Holes are drilled from the surface into the fields being worked; the gas is drawn out through them into the atmosphere or is flared. The work safety of the miners is guaranteed; however, millions of cubic meters of one of the most valuable types of raw material and fuel are wasted; in addition, the environment is polluted. The experience of the production association, Donetskugol', in particular proves that methane can be used with great profit from the national economy.

The boiler room of Mine Administration imeni Gazeta SOTSIALISTICHSKIY DONBASS Newspaper does not differ outwardly from others. But heat engineer Yu.I. Markov turns our attention to one feature: Neither coal nor natural gas is used as fuel here, but quality standard methane extracted from breakage faces instead. There is quite enough of it to heat the mine's above-ground complex. According to Yuriv Ivanovich, methane's utilization rate increased this year because of the introduction of contact waste gas heaters in the boiler room.

At Donetskugol', six mines have begun to use quality standard methane extracted from their faces for heating operational and administrative buildings. It was more difficult for the remaining 11 enterprises of the association, whose work sites are supersaturated with substandard gas (with methane concentrations of less than 30 percent). There was no possibility of utilizing it for a long time. The scientists of the Donetsk Polytechnic Institute and the Moscow Institute of Fossil Fuels came to the assistance of the miners. They developed the GPS-1 unit, which was put into operation for the first time in the country by the Donetsk miners.

One worker is at the control panel of the unit. The instruments sensitively track the feeding of mine gas to the automatic mixers. Every day, they enrich 11,000 cubic meters of methane. In special chambers, it is saturated to the required quality for natural gas and fed to the boiler room.

For 5 years already, the Mine imeni Gor'kiy has been using this fuel to heat not only its above-ground complex, but also the nearby Kristall Motion Picture Theater, an athletic arena, a nearby plant and the city fire protection administration.

"Saturated methane is almost equal to coal or natural gas in energy quality," says the mine's heat engineer, Yu.M. Lapin. "In addition, every year at least 3,000 tons of standard fuel are saved, which is profitable for both the enterprise and the national economy as a whole."

The GPS-1 has become an experimental link in the chain of systems developed to enrich substandard methane. The scientists of the same institutes have proposed another gas preparatory unit, the GPS-2; its installation is already being completed at the Oktyabr'skaya Mine. It is intended for reprocessing mine gas with a methane content of only 2 to 2.5 percent, ten times less than the amount the GPS-1 brings. And there are several mines in the association in that category.

"The new unit is also useful in that not only natural gas but also coal, which is local and for that reason a cheaper raw material, can serve as the component. And incidentally, not much of it will be required," emphasizes V.G. Lavrik, the docent of the Donetsk Polytechnic Institute.

The first GPS-2 unit will start operating at the end of this year, but a GPS-3 unit is already taking shape on the drawing board. It will be utilizing 22 to 24 percent methane by mixing it with products of complete combustion, put simply, with flue gases. The design proposed by the Kazakh VNIPIenergomash [All-Union Scientific Research Industrial Institute of Power Machine Construction] Institute is extremely simple and guarantees waste-free production. Coal will be required only during the initial start of the boiler, and then the combustion products will maintain the necessary temperature for building up steam. The expected saving of funds is at least 20,000 rubles per year.

The Donetsk miners will also test the new unit.

Today seven mines of the Donetskugol' Association are utilizing 43 percent of the methane. Thousands of tons of standard fuel are saved yearly. It is also important that the environment around the mines is now considerably cleaner. It is no longer necessary to spend vast funds on eliminating the consequences of releasing methane into the atmosphere.

"And we plan to utilize all of the methane by 1990," says A.D. Burkal', the senior engineer of the association's power machinery service. "We will introduce GPS units to the remaining 10 mines; we will be making highly efficient use of each cubic meter of the mine gas."

Considerable experience in using standard and substandard methane is accumulated in the oblast. But it must be noted that only the Donetsk miners are putting it into operation. A great number of torches continue to burn above the mines' coal fields. And after all, it is not necessary to go far for experience in efficient handling of methane; it is nearby.

12478  
CSO: 1822/123

## ENERGY CONSERVATION

### MEASURES FOR ELIMINATING FUEL LOSS AT TRANSPORTATION, FUEL DEPOTS

Baku VYSHKA in Russian 7 Dec 83 p 3

[Article by members of the Raid Team: D. Ibragimov, driver; F. Melikov, chief inspector; M. Lazarev, senior engineer, Gosnefteinspektsiya Goskomnefteprodukty [State Petroleum Inspectorate of the State Committee for the Supply of Petroleum Products] of the Azerbaijan SSR, N. Mushailov, public correspondent; and O. Nechipurenko, VYSHKA correspondent in the column "To Economize in Large and Small Things": "Where Fuel Is Lost. The VYSHKA Raid"]

[Text] The decree of the CPSU Central Committee and the USSR Council of Ministers which is published in today's issue of VYSHKA emphasizes the need for efficient, economical consumption of fuel lubricants.

There are also great potentials for saving petroleum products in our republic. They consist of the elimination of losses at petroleum depots and departmental filling stations and also in changing the system in use until recently of providing fuel to State and private motor transport. In this system it was possible, with practically no obstacles, to fill up the tank, not with a market coupon, but with a cheaper State coupon. As a result, every year in the republic, approximately 500,000 rubles worth of gasoline are lost. At the present time, measures have been taken to correct this abnormal situation.

#### "Miracles" with Coupons

At filling stations now, the sale of gasoline to State and private motor vehicles is clearly differentiated. Since the middle of October, approximately 40 raids have been conducted at filling stations by the controlling agencies of the republic State Committee for the Supply of Petroleum Products. As a result, during one of the raids conducted on 22 October, violations of the rules for selling fuel--attempts to refuel a private motor transport using uniform State coupons--were exposed in 7 out of 8 filling stations, and on 3 November, there were 4 out of 12; then from 4 through 8 November, not one such attempt was ascertained during inspections conducted at 15 filling stations.

The results were immediately evident. In the following 10 days, the sale of coupons from the market fund more than doubled.

As far as uniform refueling coupons of the State motor transport are concerned, the following situation has developed: As of 1 October, all of the coupons without a special mark were declared invalid. It turned out that a large number of unsold coupons were accumulated in many enterprises and organizations.

As an example, it is possible to cite the Construction Administration of Mechanization (SUM) of the Azneftekhimzavodremont Trust, which was described to us as one of the largest consumers of fuel at the Baku Petroleum Depot. Coupons for almost 30,000 (!) liters of motor gasoline A-72 and A-76 and almost 6,000 liters of diesel fuel remained unsold here on 1 October. According to current figures, during the period from the beginning of the year, the enterprise barely complied with the rates of fuel consumption for motor transport fulfilling the State Plan for shipment transport. And even overexpenditure was allowed when using gasoline in road construction equipment.

Z. Agayev, the committee chairman of the trade union administration and a fuel lubricants technician, tried to explain the situation.

"The fact is that since the beginning of the year, we have been trying to use mainly fuel obtained from the petroleum depot's tanks," he said. "And the coupons were kept in case there were interruptions in deliveries, which often happens. In addition, for a long time, our bookkeeping staff was not at full strength, and the payment of coupons was delayed."

It would be possible to believe such an explanation, but the trouble is, it is hard to check it. We looked at a sampling of several itinerary sheets of the drivers, and we were convinced that not one of them was filled out correctly. In particular, the number of kilometers that a truck traveled is not always shown.

"What can you do? Eighty percent of our trucks are operating with defective speedometers," declared V. Muradov, chief of the SUM Maintenance Department.

However, even when the speedometer is considered functioning, its readings cause serious doubts. We were convinced of this when examining motor vehicle KAZ-608, whose speedometer, which driver A. Saprykin said confidently was operating in good order, turned out not to be sealed.

In PMK-7 of the State Committee for Agricultural Equipment, 36 motor vehicles of various brands operating in different areas of the republic refuel only with coupons obtained from the Apsheronkiy Administration of the Rayon Agricultural Equipment Association. Because of the fact that PMK did not have funds in its account, the Rayon Agricultural Equipment Association issued it coupons irregularly. However, unused coupons for 15,000 liters of gasoline A-76 and A-72 remained here at the end of the third quarter!

When G. Gasanov, the business manager of the Rayon Agricultural Equipment Association found out about this, he was sincerely surprised.

"What can you do?" he said. "We issue them coupons, but we cannot control how they are used. PMK-7 is not under our supervision."

Really, a strange situation is created. We were convinced ourselves of what the absence of control over the use of fuel led to. According to the distribution record which PMK-7 mechanic A. Mirzoyev showed us, it was apparent that drivers with motor vehicles running on gasoline A-72 receive coupons for the more expensive gasoline A-76.

"No other way is possible," A. Mirzoyev explained. "They have long routes, and it sometimes happens that there is no gasoline of the required quality at the filling stations. That is the reason that they are supplied with different coupons as a precaution."

But let us return to the fuel "saved" here by the end of the third quarter. According to the accounting figures, approximately 100 tons of gasoline, including AI-93, were used by a motor vehicle that was not even included in the motor vehicle list of the PMK-7, and 3,000 liters of diesel fuel were used. During August-September alone, 17,308 liters of fuel (including diesel fuel) were saved here. It looks like this corresponds to the number of coupons remaining at the end of the quarter. But here is the trouble: It is hard to understand where this saving came from. For example, motor vehicle GAZ-53 driven by driver G. Allahverdiyev would have had to use 2,134 liters of gasoline for the number of kilometers driven; however, from the report signed by the same A. Mirzoyev, it looks like the truck did not use it at all(?!). And there were many such "miracles" in that report.

It was necessary to turn to the primary documents--the itinerary sheets--but they clarified little. For example, on itinerary sheet No 302928 of O. Agayev (motor vehicle GAZ-53 No 50-97 AGL), many figures were missing, such as the departure time, the odometer reading, and so on. In addition, this document covering 24-28 October was returned to PMK-7 only in the middle of November.

The same situation also exists at many enterprises of other ministries and departments, particularly, the Ministry of the Food Industry, the Ministry of Motor Transport, the Ministry of Trade, and the Ministry of the Meat and Dairy Industry.

#### A Drop Per Second Is a Ton Per Year

If barriers have been created at the present time in the way of fuel losses from the confusion with coupons, then, as we were convinced, little has been done so far in the matter of preventing the losses of petroleum products when they are stored at depots, warehouses, and departmental refueling centers and during transportation.



True, there are also good enterprises. They include the Port-Ilichichevskaya Petroleum Depot, whose collective was awarded first place and a Challenge Red Banner for winning the All-Union socialist competition for three quarters of the year by the decision of the USSR State Committee for the Supply of Petroleum Products and the Central Committee of the industrial workers trade union. Because of the high level of working conditions and standards of production, accurate accounting, control of fuel consumption, and other factors, this petroleum depot's fuel losses for this year were considerably below the norms.

But, unfortunately, there are few such enterprises. In September, for example, the State Petroleum Inspectorate exposed serious violations in the matter of storing petroleum products in the Lenin Power Supply Network, about which Azglavenergo also reported. However, a repeat inspection showed that the situation had not changed as yet. A-72 and A-76 gasolines were put into tanks located at an intolerably close distance to each other through the same pipeline. And this naturally resulted in a lower quality of fuel.

We already mentioned above that the Construction Administration of Mechanization [SUM] of the Azneftekhimpzavodremont Trust is one of the largest consumers of fuel in Baku. A large puddle of diesel fuel at the filling station clearly illustrated that it is not especially cared for here. There were also no instruments here that would make it possible to determine the amount of fuel in the underground tanks. The only instrument is a so-called probe, a rusty curved metal rod. Using it and a number of complicated calculations, fuel lubricants technician Z. Agayev "established" that there were 15,500 liters of gasoline in the tank.

"The republic All-Union State Standard refused to examine and calibrate our instruments," said Yu. Volkov, the SUM chief engineer, seeing our perplexity.

And one more important detail: There was no special breather valve in the tanks. The vehicles were refueled with diesel fuel through the usual hose and not through a so-called "nozzle." This means that the fuel evaporates freely from the tanks.

It must be noted that if gasoline in enterprises and organizations is more or less taken care of, then they sometimes do not think about saving diesel fuel at all. A considerable amount of it is also lost during transportation.

In the yard of the Apsheronkiy Administration of the Rayon Agricultural Equipment Association, we saw several motor tanks from under which diesel fuel was dripping (a drop per second is more than a ton per year!).

There were deficiencies here in meeting other requirements for transporting petroleum products. As it turned out, both fuel and oil are transported in the same tanks.

"Now we are trying to specialize transportation," says Chief Engineer R. Sadykhov.

This must be done immediately. In fact, the Apsheronskiy Administration of the Rayon Agricultural Equipment Association supplies scores of kolkhozes, sovkhoses, and other agricultural organizations with fuel lubricants, and tons of fuel are lost during transportation, and its quality is sharply reduced.

The primary duty of the collectives of all of the organizations is to close all the channels through which petroleum products are lost.

12478

CSO: 1822/125

## ENERGY CONSERVATION

### MOSENERGO EXPERIENCE IN IMPROVING FUEL AND ENERGY CONSERVATION

Moscow PLANOVOYE KHOZYAYSTVO in Russian No 12, Dec 83 pp 104-108

[Article by I. Yershov, deputy chairman, Mosgorispolkom, and Ye. Kuznetsov, Mosenergo production-technical department chief: "Ways of Improving Economies of Fuel-Energy Resources (From Work Experience at Mosenergo)"]

[Text] The Soviet Union is the only large nation which meets its energy needs through its own resources. However, this requires huge outlays, as fuel extraction is becoming ever more expensive. Therefore the party and government are constantly giving great attention to the rational use of energy resources. At the 26th CPSU Congress stress was put upon the general state importance of fuel and energy conservation in the national economy and domestic use. These problems are becoming especially acute for the European part of the nation, including Moscow, which are far removed from the main fuel extraction areas.

The Moscow energy system is part of the nation's Unified Energy System and supplies electrical and thermal energy to Moscow and Moscow Oblast. Mosenergo is distinguished by electrical energy generating capacity growth rates which are higher than the national average. This is based on the efficient cogeneration of electrical energy and heat at central heat and electric power stations. Over the past 20 years the level of central heat supply in Moscow (i.e. the share of heat supply from TETs) has increased from 42 to 78 percent. The electrical generating capacity at Moscow TETs has increased from 1 to 6 million kW and their heat generating capacity has increased from 4,350 to 22,700 Gcal/hr. These levels of central heat supply are not only the nation's, but also the world's largest.

A large share (about 70 percent) of electrical energy at TETs is produced from the heat supply cycle, i.e. through the complete use of energy from waste steam. This causes low unit fuel consumption for electrical energy production: 229.3 grams per kWh for Moscow city TETs and 265.8 grams per kWh for Mosenergo in general. These figures are considerably lower than sector indicators (327.5 grams per kWh). Moscow's central heat supply saves around 4 million tons of fuel annually.

The main task facing the Mosenergo collective is to improve the stability of electricity and heat supply to customers. Here are the main ways this is being

done: Increasing the energy production potential on the basis of technically progressive equipment, the reequipment of electric power stations (the replacement of obsolescent equipment), improvements in repair services and increases in equipment operating levels, work focused on reducing losses in energy supply systems and reductions in consumption for in-plant needs at electric power stations.

Increases in energy production efficiency depend mainly upon improvements in the structure of generating capacity. In the past decade it has experienced great changes in Mosenergo. Since the beginning of the 1970's Moscow's power engineering operations have been introducing very large central heat supply units with a capacity of 250,000 kW. Each of these can supply heat to an urban region with a population of 300,000. The transition to more modern types of machinery has made it possible to annually save 40,000 tons of standard fuel at each unit compared to the previously used equipment (100,000 kW blocks). Increases in unit size have also reduced metal intensity and unit capital outlays and also increased labor productivity and output-capital ratios. There are now 12 such units operating at Moscow TETs.

For Mosenergo as a whole there have been progressive changes in the structure of generating capacity over a relatively short time because of the development of oblast condensation electric power stations with units having steam working parameters of 130-240 atmospheres. This has reduced unit fuel consumption for generating electrical energy. Compared to 1970, by 1982 it had declined at all energy blocks by almost 30 grams per kWh (from 295.1 to 265.8 grams per kWh). Unit fuel consumption under condensation operating conditions declined by 53.6 grams per kWh (from 426.5 to 372.9 grams per kWh). Compared to 1970, the economical generation of electrical energy under central heat supply conditions increased from 375.5 to 491.1 kWh per Gcal of waste heat (30.8 percent).

During the 11th Five-Year Plan, Minenergo's development will be based primarily upon the further introduction of economical 250,000 kW heat supply units. Another five of them will be introduced at Moscow TETs.

In the longer term perspective (due to the constraints upon the use of organic fuels in the European part of the nation) alternatives are being examined for increasing the water heater boiler capacity of TETs and connecting them to the general heat supply system of electric power stations. Jointly with the Uralsk Turbomotor Plant, Minenergo [Ministry of Power Machine Building] has completed the development of units, the introduction of which will increase the use of pre-heated water at boiler units of 250,00 kW energy blocks by 1.5 fold and increase central heat supply electric power generating capacity by about 8 percent. These measures, and the more complete loading of heat supply outlet lines during the heating season will ensure annual fuel savings per unit amounting to 13,000 tons of standard fuel.

From a national economic perspective, the new method of covering heat demand through the installation of additional boilers at TETs, while it reduces the coefficient of central heat supply by 0.3 - 0.35 percent, is more advantageous than the construction of new regional boilers. This was first done at the Mosenergo TETs-16. This solution can also be applied to the joint operation of

energy sources (central heat and electric power stations and regional boilers) to the general heat supply system and to systems similar to the heat supply system in Minsk, where city boilers are used as a peak hours source of heat for TETs.

The levels of conservation in Mosenergo operations are affected by factors of a general sectorial character. In recent years there has been a lack of correspondence between the growth in energy consumption and the introduction of new generating capacity. This has led to the operation of equipment without the essential reserves and repairs, reducing its reliability and causing additional fuel consumption for the production of electrical energy. In Mosenergo, this amounts to about 2 percent, or 300,000 tons of standard fuel annually. The elimination of this situation requires an acceleration of the installation and operational introduction of new energy capacity through the development and practical introduction of progressive design decisions and equipment in power engineering construction to reduce capital intensiveness and to attain highly economical operation at Mosenergo electric power stations.

Together with this there should be increases in the efficiency with which new progressive energy equipment is used. This is often reduced because of the prolonged time required for its introduction resulting from curtailed start-up complexes. Energy projects are sometimes put on line with incomplete designs and unfinished work on fuel and water purification installations, without cooling towers and other auxiliary installations. As a result, capacity gaps are not overcome for many years, equipment works uneconomically and its operation is made more complex.

The technoeconomic indicators of energy association operation are also considerably influenced by the pace of equipment modernization. The reconstruction of power stations having obsolete and obsolescent units has now become a major general sectorial problem. There is unjustifiable slowness in the withdrawal and replacement of obsolete fixed capital.

There is a marked slowdown in the rates of reducing unit fuel consumption. While during the 1960's its consumption per 1 kWh was reduced by 57-48 grams during the five-year plans, in the 1970's it was only 26-12 grams. In 1982 there was an increase in this indicator compared to the previous year's level.

The Moscow energy system is one of the nation's oldest. A sizable share of the equipment at its electric power stations is in need of modernization. At the beginning of the 1970's a program was prepared for the modernization of Mosenergo TETs with obsolete equipment. It provides for the removal of old and the installation of new equipment. Mosenergo will replace obsolete units with equipment produced by Minenergomash plants. Equipment accounting for 6.5 percent of total energy system capacity (at 9 of 19 stations) is subject to replacement. Condensation equipment is being removed without replacement. Power station reconstruction will improve the efficiency and reliability of energy supply. Obsolete equipment has a specific central heat supply output of electrical energy (consuming 157 grams per kWh) of about 200-300 kWh per Gcal. With the transition to improved steam parameters this can be increased to

600-700 kWh per Gcal. For the system as a whole, progressive changes in the structure of TETs generating capacity will ensure an annual fuel savings of up to 300,000 tons.

The enlargement of existing equipment's unit capacity and the conversion of a number of coal burning TETs in Moscow to gas and mazut which is now underway can release more than 1,000 service personnel. It is also planned to improve other energy system economic indicators, including the reductions in outlays for repairs and in the prime costs of energy generation.

In the planned reconstruction of Mosenergo power stations it is possible to include the variant of installing, in the main buildings, TR-110 type small heat supply turbines, a shortened modification of T-110-130 turbines. It is intended to install the first such turbine at TETs-12 in the next five-year plan.

The implementation of the program to reequip Mosenergo energy enterprises requires extensive resources. In addition to centralized capital investments, production development funds must be used for these purposes. In accordance with the CPSU Central Committee and USSR Council of Ministers Decree of 12 July 1979, this fund can be increased through deductions from profits and the allocation of up to 50 percent of the depreciation allowances intended for the complete reconstruction of fixed capital. At Mosenergo it now only amounts to 7-9 million rubles, while annual capital investments are up to 200 million rubles. The technical modernization program requires that construction-installation organizations' activities be more oriented towards reconstruction work.

The problem of replacing obsolete equipment is becoming urgent not only with regard to its economic aspects, but also from the perspective of ensuring the necessary levels of energy supply reliability. While previously only units with average parameters were dismantled at Mosenergo, the estimated service life of units with higher parameters has now been reached (they were installed in the 1950's-1960's). The metal of high pressure (130-240 atm.) installations is not intended for such a long service life as on installations with parameters up to 35 atm.

As it is unrealistic to replace equipment on a massive scale, Mosenergo is replacing individual unreliable components. Considerable difficulties arise here, as Minenergomash plants are not producing the required parts and assemblies in the necessary volumes and assortments.

One of the important factors influencing the economy of thermal electric station operation is their work conditions, determined by the coefficient of daily load variation. It is 0.65 for the Unified Energy System for the nation's Center. Nighttime loads are more than one-third lower than daytime loads. The drop in energy consumption during the night hours causes massive declines in the loads of power stations and their operation under uneconomical conditions. Load drops and shutdowns of equipment lead to increases in wear, declines in economy and reliability and to frequent repairs. In addition to condensation stations, TETs have been enlisted into the regulation of load schedules. However, this means losses in economical central heat supply output of electrical energy.

The existing capacity structure in power production is not appropriate to rational conditions for energy consumption. The share of special flexible equipment is extremely low. It is only 0.4 percent of installed capacity, instead of the required minimum of 8-10 percent. In the future this situation will become even more acute, as nuclear power plants (the share of which is continuously growing), have limited flexibility. The use of nuclear power plants for base loads is more advantageous, as they are highly capital intensive and fuel costs are a low percentage of energy production prime costs. It is therefore essential to speed up the introduction of special energy equipment.

During peak loads at Mosenergo, 3 gas turbine units of 100,000 kW each are put on line. In the next five-year plan it is intended to expand this through the installation of more powerful 150,000 kW gas turbines. The nation's first large pumped storage power plant, having six 200,000 kW units is being built in Zagorsk. Power engineering should also develop other promising types of flexible equipment: special steam turbine blocks, compressed air storage gas turbine units and steam-gas cycles. It is also essential to use the possibilities of load schedule smoothing through the change of energy intensive manufacturing processes to night shifts and non-working days. In addition, there should be improvements in the organization of energy transmission from power plants directly to customers. At present 8-9 percent of all energy produced is lost in the distribution systems. To a sizable degree this is due to the insufficient number of compensating devices (synchronous condensers, condenser batteries and adjustable transformers). The needs of industrial enterprises and USSR Minenergo for static condenser batteries are met by less than one-third, and for synchronous compensators by approximately 10 percent.

The economic indicators of power engineering enterprise operation are to a great extent determined by fuel quality. Unfortunately, for a number of reasons coal quality is deteriorating year after year; its moisture and ash content are increasing. The latter involves increased amounts of rock and additional energy costs in pulverizing fuel, heating surface wear, and a 1.5-2 fold reduction in boiler service life, unplanned shutdowns and repairs and to considerable overheating [perezhog] of fuel. In addition, increased ash content means the useless and expensive transport of rock across great distances. Studies show that for Mosenergo alone this requires about 20,000 additional freight cars annually. Therefore, questions concerning the economic advisability of coal preparation at mining sites are on the day's agenda. USSR Minenergo institutes have estimated the sector and national economic losses from reductions in coal quality. These studies could be used in solving this problem.

Improvements in the economic mechanism and planning and in enhancing the effectiveness of incentives for attaining better final indicators are very important directions for improving the work of Mosenergo energy enterprises.

At present the main plan indicators for electric power plants are the readiness of equipment and the unit fuel consumption for the production of 1 kWh or 1 Gcal. The production of electrical energy and heat is not planned, but is estimated for the balances of fuel and energy supply. This system is oriented towards attaining better fuel use indicators, but does not provide the necessary incentive for the most complete use of capacity. The indicator of equipment readiness for loads and the load schedule operationally set for the power plant cannot completely offset these negative tendencies.

In our opinion, this requires a reexamination of the plan indicator system for power engineering. The formation of incentives funds is also linked to this. Under conditions of a taut electric power balance and the growing unevenness of daily loads, this system should direct power plant personnel towards the use of all capacity reserves and towards meeting requirements for high levels of economy in their work. With this in mind, Mosenergo has developed measures to change the incentives system for thermal power plant personnel. It is intended to award bonuses for attaining and reducing the planned unit fuel consumption norms, but with consideration given to plan indicators for electricity output in daytime hours and load drops during the night. This system requires the separate planning and accounting of electricity output during these periods.

The scientific basis of plan targets is an important condition for improving planned work. In order to have this, the Moscow energy system is using computers to create mathematical models of working conditions at thermal electric power plants, not only condensation plants, but also TETs, which have more complex systems. This is the basis for a model of the unified energy system which will make possible the optimal distribution of electrical and thermal loads between power plants, with the criteria being minimal fuel consumption.

In our view, this requires further improvements in planning at the upper sectorial level. It is not unusual for USSR Minenergo to give energy systems plans which are insufficiently balanced with expected energy consumption. Consequently, taking actual working conditions into consideration, energy output plans are, as a rule, increased, but fuel indicators are not always corrected. This does not mobilize personnel for the complete use of equipment capacity. It is essential to work out a planning system coordinated for all indicators and regions. In our opinion it is advisable to have a long term sector fuel consumption forecast, taking into consideration the influence of many factors on fuel utilization. This will make it possible to discover changes and the most effective ways of reducing consumption.

Problems in the economy and reliability of energy generation are closely linked to the skills of personnel, the stability of their composition and further improvements in payments for labor.

The consumption sphere has great potentials for reducing the use of energy. The 26th CPSU Congress posed the task of ensuring fuel-energy savings for the entire national economy during the five-year plan amounting to 160-170 million tons of standard fuel, including 70-80 million tons through the reduction of consumption norms.

Moscow should also make its contribution to the solution of this task. An analysis of city energy operations is evidence of sizable reserves in this regard. The general coefficient of usefully consumed energy resources is 45-47 percent. This is higher than for the national economy in general, but it is insufficient for Moscow in view of the better structure of energy converting installations.



According to estimates of USSR Minenergo's VNIPIenergoprom [Scientific Research and Planning Institute for the Power Engineering Industry], the potential annual fuel savings which could be attained in the immediate future is 5-6 million tons of standard fuel. Of this total, roughly 1.5 million tons is attributed to Mosenergo and 3.5-4.5 million tons to industrial and communal-service operations in the city.

Fuel and energy resource savings in the consumption sphere are attained through well based norms, the development and introduction of organizational-technical measures and progressive technology and the strict, well organized accounting and control over resource use.

Improvements are needed in the norm setting system for energy resource expenditures. Unfortunately, in our practical operations the so-called estimation-statistical method of norming has taken hold. It does not give sufficient consideration to scientific and technical achievements or to progressive foreign and domestic experience. As a result, the unit consumption of energy for the production of many kinds of products in our nation considerably exceeds progressive indicators, often obtained with the same equipment and under similar conditions. Moreover, enterprises observing such wasteful norms are counted as progressive with respect to "economies" of fuel and electrical energy and are even awarded bonuses for this.

It is essential that norm setting for energy use in all sectors be put on a scientific basis and a specific long term program developed. Of great interest in this respect is the targeted program for savings of fuel and energy resources for 1982-1985 and up to 1990 being carried out in Leningrad and Leningrad Oblast. It was developed by the North-West Department of VNIPIenergoprom at the order of the USSR GKNT [State Committee on Science and Technology], USSR Gosplan and the Leningrad Obkom. The implementation of these measures will save the region fuel and energy resources equal to 6 million tons of standard fuel during the current five-year plan and 13 million tons in the next plan. This is respectively 2 and 4 fold greater than the savings attained in the 10th Five-Year Plan.

There are reserves for energy savings in all sectors of industry and communal-residential operations. The rationalization of energy consumption conditions (optimization of equipment, heating and illumination loads) is the simplest way to attain noticeable economies. In industry this could save about 10 percent of the energy consumed, without reductions in production volume.

Great attention should be given to measures for improving efficiency coefficients of electricity and energy consuming installations and to reducing the energy intensity of manufacturing processes. In construction the introduction of stricter norms and standards for buildings' insulation and the automatic control of energy consumption in buildings could reduce energy consumption by up to 35 percent. In order to attain this, Minpribor [Ministry of Instrument Making, Automation Equipment and Control Systems] should rapidly expand the mass production of devices for the automatic control of heat supply.

Secondary energy resources are a great reserve for conservation. The levels of their use for the national economy in general are still very low -- 58 percent. Work on the use of these resources is slow, mainly because of the lack of heat utilization equipment, including heat recovery boilers, heat exchangers, recuperators, equipment for evaporative cooling, etc.

It is also essential to create and introduce, into energy intensive sectors of industry, combined manufacturing processes, which have practically no heat losses. The coefficient of the useful utilization of fuel in such processes reaches 92-94 percent.

The organization of the economical use of fuel resources is impossible without precise, well organized accounting. At present its standards are quite low due to there being no mass produced instruments for controlling electricity and heat consumption.

The problem of developing organizational schemes for territorial management is also important. It is especially acute for heat supply. For example, the units active in the organization of heat supply include: Mosenergo (combining TETs and main heat supply lines), about 700 legally and economically independent ministries and departments, and a number of contracted scientific, planning and construction organizations. This extreme fragmentation reduces the efficiency and quality of heat supply. Organizational measures are also needed. In particular, the Academy of Communal Operations imeni K. D. Pamfilov has developed proposals for the maximum economic and managerial integration of all units in the system.

Thus, power engineering workers in Moscow and the oblast have great reserves for improving the efficiency of energy resource use. They can be realized through the joint efforts of workers in power engineering and in other ministries and departments.

COPYRIGHT: Izdatel'stvo "Ekonomika". "Planovoye khozyaystvo". 1983

11574

CSO: 1822/114

END