

075055

JPRS-UEN-84-003

23 January 1984

USSR Report

ENERGY

19981023 115

DTIC QUALITY INSPECTED 2



FOREIGN BROADCAST INFORMATION SERVICE



9
125
A06

NOTE

JPRS publications contain information primarily from foreign newspapers, periodicals and books, but also from news agency transmissions and broadcasts. Materials from foreign-language sources are translated; those from English-language sources are transcribed or reprinted, with the original phrasing and other characteristics retained.

Headlines, editorial reports, and material enclosed in brackets [] are supplied by JPRS. Processing indicators such as [Text] or [Excerpt] in the first line of each item, or following the last line of a brief, indicate how the original information was processed. Where no processing indicator is given, the information was summarized or extracted.

Unfamiliar names rendered phonetically or transliterated are enclosed in parentheses. Words or names preceded by a question mark and enclosed in parentheses were not clear in the original but have been supplied as appropriate in context. Other unattributed parenthetical notes within the body of an item originate with the source. Times within items are as given by source.

The contents of this publication in no way represent the policies, views or attitudes of the U.S. Government.

PROCUREMENT OF PUBLICATIONS

JPRS publications may be ordered from the National Technical Information Service (NTIS), Springfield, Virginia 22161. In ordering, it is recommended that the JPRS number, title, date and author, if applicable, of publication be cited.

Current JPRS publications are announced in Government Reports Announcements issued semimonthly by the NTIS, and are listed in the Monthly Catalog of U.S. Government Publications issued by the Superintendent of Documents, U.S. Government Printing Office, Washington, D.C. 20402.

Correspondence pertaining to matters other than procurement may be addressed to Joint Publications Research Service, 1000 North Glebe Road, Arlington, Virginia 22201.

Soviet books and journal articles displaying a copyright notice are reproduced and sold by NTIS with permission of the copyright agency of the Soviet Union. Permission for further reproduction must be obtained from copyright owner.

23 January 1984

USSR REPORT

ENERGY

CONTENTS

FUELS

OIL AND GAS

Oil Ministry Official Comments on Production (V. Igrevskiy; EKONOMICHESKAYA GAZETA, No 39, Sep 83).....	1
Komineft' Director on New Methods of Oil Recovery (A. Gumenyuk; SOTSIALISTICHESKAYA INDUSTRIYA, 9 Aug 83).....	2
Exploration of Oil Region Revitalized by Discovery (A. Guseynov, et al.; VYSHKA, 5 Nov 83).....	6
Tarsdallyar Oil Flows (S. Garayev; VYSHKA, 6 Oct 83).....	9
Bulla Oil Production Report (O. Nechipurenko; VYSHKA, 16 Nov 83).....	10
Donetsk Institute Helps Design Pipelines From Urengoy, Yamburg (Boris Frolovich Leshchinskiy Interview; PRAVDA UKRAINY, 12 Oct 83).....	11
Jobs on Northern Pieplines Advertised (STROITEL'NAYA GAZETA, 23 Oct 83).....	14
Preparation for Winter at Azerbaijan Platformmaking Plant Criticized (P. Kasumov; VYSHKA, 10 Nov 82).....	16

Use of Steam Enhances Recovery at Oil Mine Near Ukhta (A. Trutnev; SOVETSKAYA MOLODEZH', 12 Aug 83).....	18
Shortage of Compressed Oxygen for Offshore Drilling Rig Construction Noted (O. Nechipurenko; VYSHKA, 31 Aug 83).....	20
Improvement in Recovery Methods, Utilization of Condensate Urged (Yu. Perepletkin; IZVESTIYA, 9 Sep 83).....	23
Briefs	
Samantepe Gasfield Helicopter Transport	27
Ekiz-AK Gasfield Starts Producing	27
Deep Caucasian Gas Well	27
Kirghizia Oil Exploration	27
Sakhalin Shelf Petroleum Exploration	28
Danilovsky Branch Gas Pipelines	28
Urengoy-Tsentr-1 Gas Pipeline	28
Kazan-Produced Pipe Carrier	28
Barsa-Gelmes on Gaslift System	29
Bridge To Arctic Fields	29
Swamp-Traveling Hauler	29
New Caspian Offshore Finds	30
New Oilfield Bulldozer-Crane	30
Tebuk Oilfield Surpasses Goal	30
Gusher in Akpatlauh Area	30
Gas Pipeline to Kishinev	31
Deep Caspian Oil Producer	31

COAL

New Mining Equipment Produced at Gorlovka Plant (A. A. Chichkan; UGOL' UKRAINY, No 9, Sep 83).....	32
Synopses of Articles in UGOL' UKRAINY, August 1983 (UGOL' UKRAINY, No 8, Aug 83).....	37
Selected Synopses of Articles in UGOL' UKRAINY, September 1983 (UGOL' UKRAINY, No 9, Sep 83).....	43

ALTERNATE FUELS

Increasing Use of Geothermal Energy (GAZOVAYA PROMYSHLENNOST' No 10, Oct 83).....	49
Introductory Statements Urgent Geothermal Development Problems, by R. S. Vorob'yeva	

Underground Circulation Systems
Disposal of Geothermal Water

Selected Synopses of Articles in TORFYANAYA PROMYSHLENNOST',
August 1983
(TORFYANAYA PROMYSHLENNOST', No 8, Aug 83)..... 58

ELECTRIC POWER

NUCLEAR POWER

First Energy Unit Put Into Operation at Smolensk AES
(V. Kapel'kin; TRUD, 1 Oct 83)..... 61

Problems of Disorganization, Mismanagement at Rostov AES
(V. Uzhakin; SOTSIALISTICHESKAYA INDUSTRIYA, 3 Sep 83)..... 63

NON-NUCLEAR POWER

Production of New 300,000 kw Turbogenerator Initiated
(S. Davydov; VYSHKA, 13 Oct 83)..... 65

Small-Capacity Thermal Plants for Economical Water Heating,
Steam Generation
(N. Rassudov, et al.; EKONOMICHESKAYA GAZETA, No 45,
Nov 83)..... 67

Briefs

Power Lines Go Underground 69

High Voltage Ring Completed 69

Power Lines Cross Irtysh River 69

Gur'yev-Kul'sary Power Link 70

PIPELINES

PIPELINE CONSTRUCTION

Construction of Pipelines From Urengoy Progressing
(M. Sil'vanovich; SEL'SKAYA ZHIZN', 12 Jul 83)..... 71

Bulgaria-USSR Pipeline Construction Progresses
(STROITEL'NAYA GAZETA, 9 Sep 83)..... 72

Too Much Pipe, Equipment Abandoned Along Rights-of-Way
(Yu. Belanov; SOTSIALISTICHESKAYA INDUSTRIYA,
26 Mar 83)..... 73

Back-up Crossing of Dnieper Built on Export Gas Pipeline (V. Luk'yanenko; PRAVDA UKRAINY, 29 Sep 83).....	76
Multilayer High-Pressure Pipe Passes Test Problems of Field Use Remain (A. Zhdanov; STROITEL'NAYA GAZETA, 24 Jul 83).....	79
Preparations Start for Third Pipeline Across Nevel Strait (B. L'vov, G. Panushkin; IZVESTIYA, 10 Jun 83).....	82
Branch Gas Pipelines Being Built to Many More Cities (G. S. Chesnokov Interview; SOVETSKAYA ROSSIYA, 20 Oct 83).....	83
Construction of Housing, Amenities in Novyy Urengoy (V. G. Vasilenko; STROITEL'STVO TRUBOPROVODOV, No 10, Oct 83).....	85
Preparations for Winter Pipelinebuilding Under Way (Yu. Belanov; SOTSIALISTICHESKAYA INDUSTRIYA, 2 Nov 83).....	88

ENERGY CONSERVATION

Azerbaijan Plans for Maximum Utilization of Energy Resources (M. Imanov; BAKINSKIY RABOCHIY, 6 Sep 83).....	90
Moldavia Conserves Energy for the Peak Fall-Winter Period (SOVETSKAYA MOLDAVIYA, 21 Oct 83).....	94

GENERAL

Housing Needs for Oil Workers in Mangyshlak (G. Dil'dyayev; KAZAKHSTANSKAYA PRAVDA, 30 Oct 83).....	96
Kazakhstan Power Plant Construction Problems, Future Needs Discussed (Editorial; KAZAKHSTANSKAYA PRAVDA, 30 Oct 83).....	101
Neryungri Workers Complain of Shortages (V. Antonov; STROITEL'NAYA GAZETA, 2 Sep 83).....	104

Problems Facing Pavlodar-Irtysh Area Power Plant Builders Outlined (V. Stupak; KAZAKHSTANSKAYA PRAVDA, 14 Oct 83).....	107
Lack of Airport Office Space, Management Problems in Katek Reviewed (E. Maksimovskiy; VOZDUSHNYY TRANSPORT, various dates).....	110

OIL AND GAS

OIL MINISTRY OFFICIAL COMMENTS ON PRODUCTION

Moscow EKONOMICHESKAYA GAZETA in Russian No 39, Sep 83 p 8

[Article by V. Igrevskiy, first deputy minister of the USSR Petroleum Industry: "valuable Experience" under the heading: Let Us Continue Discussion"]

[Text] The No. 2 Surgut Administration of Drilling Operations in the past year achieved important successes. Over the years 1980-1983 its personnel drilled through 1.8 million meters of rock and built 719 wells. The amount of drilling footage rose by more than 50 percent.

These positive results were well disclosed by the chief of the administration, Hero of Socialist Labor G. M. Levin in an article: "Not by Number But By Skill" published in the 31st number of the weekly. The Ministry of the Petroleum Industry takes all measures to propagate the experience of the leading UBRs [Administrations of Drilling Operations] in organizing operations.

It must be kept in mind that the powerful drilling organizations of this same Glavtyumenneftegaz [Main Administration of Tyumen Oil and Gas Production] are not able to meet the planned rates of growth in the volume of operations. In this connection, the Ministry of the Petroleum Industry is using the expeditionary-shift method of drilling wells. At present in Western Siberia, 131 drilling brigades, 35 derrick installation brigades, and 55 brigades for the exploitation of wells are working by this method. Over the years 1978-1983 they have constructed 5,260 wells and drilled through 15.9 million meters of rock.

In the Glavtyumenneftegaz organization the stimulation of drilling enterprises, working both in the usual way and in the expeditionary-shift method, is carried out according to the specific results of their work - for completed production. For each enterprise a quota is established for the formation of a material incentive fund.

This system of stimulation permitted the No. 2 Surgut UBR to make payments from the fund in the past year in the amount of 866 rubles for each worker. In other UBRs, not yet achieving such positive results but paid according to similar quotas, payouts from the material incentive fund amounted to from 770 to 800 rubles. G. M. Levin, the author of the article, quite correctly pointed out the shortage of bits. The Ministry of the Petroleum Industry and the Ministry of Chemical and Petroleum Machinery are currently working on this so as to fully equip drilling organizations of Western Siberia and the sector as a whole with roller cutter bits.

OIL AND GAS

KOMINEFT' DIRECTOR ON NEW METHODS OF OIL RECOVERY

Moscow SOTSIALISTICHESKAYA INDUSTRIYA in Russian 9 Aug 83 p 2

[Article by A. Gumenyuk, general director, Komineft' Association: "Heavy Oil, Learn Lessons from Miscalculations"]

[Text] Each day sees a number of block trains filled with hot oil leave the approach tracks of the Yareganef't' mine administration. Processing facilities take this raw material, which possesses some unique properties, and produce high-quality bitumens from it, bitumens for paint, varnish, freeze-resistant lubricants and winter diesel fuel, for example.

Now when I said hot, I meant just that—this oil really is hot, because here at the Yarega field we are using the thermal-enhancement method of recovering oil, that is, by actually heating the productive section with steam. The problem was that the methods which had until recently been employed in working the formation here had shown themselves no longer to be adequate. Production was declining sharply, and the producing formation was refusing to give up its riches. Each ton of oil was becoming so expensive that it was with complete justification that we began to discuss the advantage to be derived from working the formation by the mining method.

We had to find a new method which would entail the introduction of radically different technologies and sharply increase oil production. There was, of course, another approach: simply close down these fields because of their unprofitability. But that wouldn't be the advantageous thing to do from the point of view of good economic management, what with the fact that we have so far recovered only a small fraction of our reserves. And then on top of that, what would we ever do with the hundred of workers?

To thin out Yarega's heavy viscous oil it has to be heated within the formation itself—this has been the conclusion drawn by our scientists and experts. But now how to do this? Laboratory tests conducted by VNIPIneft' [All-Union Scientific Research and Planning Institute of the Petroleum Refining and Petrochemical Industry] and PechorNIPIneft' [Pechoa Scientific Research and Planning Institute of the Petroleum Refining and Petrochemical Industry] showed that steam would be the best heat carrier. It would easily penetrate the pores, interstices and fissures of a formation, fill them and create the pressure which had been lost as the field was worked.

Results achieved by the introduction of this new technology have exceeded all expectations. While an average of three per cent of the oil in a formation could previously be recovered, it had now been increased 10-fold and more. The steam-heat process introduced at Yarega, a process which exploits the effect of steam upon an oil-bearing formation, is what the industry refers to as a "secondary method" of recovering oil. And at no other site is the industry offered the opportunity it is here to observe directly, inside a formation itself, the results of a test and then to modify the approach.

This innovation on the part of the Yareganefit' administration, which for many years now has been in the hands of probing, inquisitive engineers such as P. Voronin and Ye. Gurov, has had a decisive impact upon the future above all of Yarega itself. As calculations now show, the introduction of thermally enhanced recovery methods [termoshakhtnaya tekhnologiya ("thermal-mine technology")] has made it possible to transfer some 35 percent of our heavy oil reserves, which until now have been considered irretrievably lost, over to the category of recoverable reserves. This is equivalent to discovering a new deposit but not having to go to the additional expense of arranging for all the geological prospecting involved and then of building and installing all the production equipment required. The new technology has also radically altered the appearance of a mine. A powerful steam-generating facility has taken shape here, while new machinery has made its appearance down below; automatic equipment is now making its way into the oil-bearing formation. It has now become possible to achieve rapid increases in oil production. The economic gains realized from the introduction of this new technology have already come to some 2 million rubles.

So a solid economic foundation has been laid for the development of plans for a radical modernization of existing mines and for the construction of three new ones. These plans are expected to be realized over a 12-year period. One of our tasks now is to accelerate work on the development at Yarega of a major operational base for the contracting organizations—Glavkomigazneftestroy and enterprises specializing in mine construction work. A program of steps has also been outlined to increase the efficiency of thermally enhanced recovery technology, while work is being completed on the automation of production operations.

Practical introduction of this method of applying steam heat to an oil-bearing formation has not been limited to the confines of the Yarega field, however. For the fact is that the assimilation of this new technology is making it possible to take a new look at the raw-material base of our entire industry, to include operations in the Komi ASSR. There is now a real possibility that we can begin on a large scale to exploit those substantial reserves of heavy oil which were formerly thought to be unrecoverable or which were no longer being worked because of low production yields from a formation. So in this sense the Yarega experience has been of enormous value for the entire industry. PechorNIPIneft' has developed plans to expand the capacity of petroleum-producing enterprises in Azerbaijan and Tartariya, plans which, too, have been based upon the method of applying steam heat to a producing formation, while in Azerbaijan work on construction of the first oil mine has already begun.

Circumstances are such that it is once again enterprises of our association which are subjecting the experience of the Yarega miners to its most critical test. There can be no doubt that these results, too, will have far-reaching consequences.

We have taken the idea of exploiting the effect of heat on an oil-bearing formation, an idea materialized in the thermally enhanced recovery method being employed at Yarega, as the basis for production operations at a heavy oil deposit at the Usinskoye field.

You'd think all this would be easy. You take something ready-made and simply re-apply it under a new set of conditions. The problem in this instance, though, is that the conditions involved aren't really comparable. The properties of the oil in these two fields alone can be said to be similar—it can be used to make very valuable products. Other than that, however, the new conditions required an entirely new approach. The producing formation at Yarega is some 150-200 meters below the surface, and the advantage to be derived from taking the mining route here is obvious. At the Usinskoye field, on the other hand, the oil deposit is over a kilometer and a half down, so the formation has to be worked from the surface. Nor are the scales on which the two operations are being conducted comparable. The development plan for the Usa calls for this site to produce more oil in a single year using secondary recovery methods than Yarega for the entire period of existence of the oil mines. All this could not but have been taken into account in launching plans for testing on the Usa.

Despite the fact that much remains to be done and that only a dozen or so shafts have so far been put down to deliver pressurized steam to the formation, the results of the test can nevertheless be considered encouraging. The past year alone has seen this limited number of wells yield more than 80,000 tons of oil from the heated formations.

There can be no doubt that the success here would have been even greater had there been no disruptions in the pace of the operations. For this we have been justly criticized by senior officials in Minnefteprom [Ministry of the Petroleum Industry]. The problem has been that this new technology is being introduced in an underequipped region which is still being developed, and it here, it seems, that our shortcomings are to be found. We could point in particular to the delay in putting in and bringing on line the new injection wells which pump the steam down to the formation. A great deal has also been accomplished in-situ combustion test section. The delay in beginning testing here has been due to changing approaches to safety standards and the redesign of a number of facilities.

But it is now not only or so much these unfortunate delays that are disturbing us. Also unfortunate is the fact that, together with the merits of the Yarega experience, the shortcomings of this approach were due to inertia incorporated in plans for the Usa site as well. All new boilers and steam-generating had been being installed in each new mine. This had become the practice, to the point that it seemed as though there were no other way to do things. So now each mine has its own steam power facility comprising several dozen boiler units of different sizes. A large number of workers are kept busy servicing them. The differences in the types of boilers used is creating shortages of spare parts and assemblies and makes equipment repairs more difficult. They also create a requirement for different chemical reagents for use in treating the water.

So now the developers working on plans and designs for facilities involved in bringing the heavy-oil pool on stream at the Usa field strike out down the same path. The only difference here, though, was that the scales involved are immeasurably larger. The result, of course, is that all the shortcomings referred

to are simply magnified several times. Four imported and five Soviet-built steam generators have already been installed at the pilot steam-stimulated production site. Now we can get along with these units during the test-production stage of the project. But when it comes time to introduce this new technology throughout the entire field here, we're going to have to bring in many dozens of these units for distribution over the entire area. We'll have to run water and gas lines in to each one along with electric power lines and hard-surface roads. This number of new facilities is also going to entail an excessive increase in the number of service personnel. And what with the fact that the service life of one of these units is not of sufficient duration, this is going to complicate the process of repairing and maintaining the equipment. So under these conditions it's going to be difficult to be able to depend on any high degree of reliability and efficiency in the system by which the oil fields are supplied with their heat carrier.

As our experience has shown, the idea of creating a large number of boiler facilities employing (as yet highly unsophisticated) steam generators of modular design in the fields, an idea forming the basis of the Yarega and Usa heavy oil field development projects, has clearly failed to justify itself. What is clear is that, from an economic point of view, it would be to greater advantage to build large, high-capacity permanent thermal power plants. Computations indicate that a single plant like this would be enough for Yarega, while the Usa project would require no more than two or three. In terms of reliability and efficiency, facilities like this would be vastly superior to the boilers and steam generators we are using now. This would also both simplify and reduce the cost of building the system of supply lines which would be required as well as reduce by several times the number of service personnel required as against what current plans call for.

I think USSR Gosplan and Minnefteprom are going to give our suggestions serious consideration. The Komineft' association, after all, is one of the industry pioneers in the introduction of thermally enhanced recovery technology into actual production operations. And it is we who have demonstrated how efficient these methods are. We will now in the near future be seeing steam-stimulated recovery emerge as the most important method of increasing production at many oil fields in the Komi ASSR. We need to insure that our early mistakes do not create obstacles to extensive introduction of this valuable experience throughout the industry. The state, after all, stands to realize no small gain from the application of this new technology.

8963
CSO: 1822/16

OIL AND GAS

EXPLORATION OF OIL REGION REVITALIZED BY DISCOVERY

Baku VYSHKA in Russian 5 Nov 83 p 3

[Article by: A. Guseynov, chief geologist of "Azneft" [State Association of the Azerbaydzhan Petroleum Industry]; Doctor of Geological and Mineralogical Sciences and Laureate of the State Prize of the Republic A. Namedov, instructor in the department of paleogeography of the Geographical Institute of the Academy of Sciences of the Azerbaydzhan SSR; and Candidate of Geological and Mineralogical Sciences F. Shirinov, head of the laboratory of tectonics and geological petroleum zoning of AzNIPIneft [Azerbaydzhan Scientific Research and Planning Institute for Petroleum]: "New Petroleum Region in Azerbaijan", under the heading: "Historical and Geological Commentary"]

[Text] Another new oil zone has appeared on the map of the petroleum producing regions of our republic; namely, the region between the Kura and Iori rivers (see VYSHKA for October 6th this year). The first exploratory well drilled in the southwestern part of the region in the area of Tarsdallyar uncovered a promising deposit. This was not just luck but a result of the prolonged and painstaking work of the scientists, production geologists, geophysicists, and drillers of the republic.

With its abundant outcroppings of oil and gas, the region long ago called attention to itself. Even in the second half of the last century primitive oil fields were created here where, in truth, extremely insignificant amounts of fuel were extracted (up to several tens of tons per year).

At the beginning of the 20th century the whole oblast between the Kura and Iori rivers underwent a period of oil frenzy. Various foreign companies greedily followed each case of natural oil seepage and, without geological grounding, sank wells. Special attention was drawn by the so-called Sarmatian sediments of the Chatma region.

In 1902, the Petersburg Petroleum Partnership proceeded to drill but did not get positive results. In the following year the partnership transferred its rights to the English company of Lord Armstrong - the owner of large machinery manufacturing plants. In 1904 this company proceeded to drill two wells. The company supposed that oil would be found at a depth of 210 m, but this hope was not justified. In the end, the company ingloriously ended its existence.

In 1913 and 1914 a French company proceeded to hunt for oil in the Sarmatian sediments of the Eldaroyuga area. Here the company sank two wells with depths of 280 and 286 meters. Both wells turned out to be "dry" and exploration of the area was stopped.

The unsuccessful results of the foregoing work by many researchers and oil men was taken as evidence that the oblast between the Kura and Iori rivers was not promising for finding deposits of fuel. Until the post-war period the region between the rivers was almost without attention, and only in the 1930s, in some areas of it, geological surveys were carried out. Those who did this work came to very different conclusions about the relative promise that the region bears oil. One of them considered the Sarmatian sediments promising, others thought the Maykopsk formation promising, and a third of them generally denied the presence of productive strata.

After World War II, geological studies of the region were recommenced. In the years 1947-1954, geological mapping, structural and exploratory drilling, geophysical, and topical investigations were carried out on a broad scale. As the result of this work, the sediments of the Sarmatian layer stood out as the principal target for oil searches. At the same time, the northern part of the region was considered the most promising. Here, in the area of Eldaroyuga, in the years 1950-1954 exploratory drilling was begun. All three wells drilled here, however, were liquidated for technical reasons and the oil bearing strata revealed in their cross sections remained unassayed. Survey of the area was suspended. At the same time, the other kinds of exploration work for oil - geological mapping and test drilling - were stopped.

Nevertheless, comprehensive scientific investigations with the purpose of studying in greater detail the geological structure and the oil and gas content of the region were continued. This permitted evaluating the potential of the oil and gas content of the region in a fundamentally new way. Specifically, it was established that along with the Sarmatian oil-bearing sediments there are Paleogene-Mesozoic sediments. It also was shown that the latter have the most favorable conditions for accumulating and retaining pools of oil and gas. All the bases for a return to the search for oil were available. The distance, however, of the region from the principal bases for material and technical supplies, the lack of surface facilities in the territory (the absence of roads, difficulty with water and electrical supplies, and so on) strongly delayed the resumption of exploratory and surveying work. The impetus for a resumption of exploration was, as they say, the good fortune of others; namely, the discovery of oil deposits in neighboring regions - in the areas of Muradkhanli and Zardob in the Kura-Araksinsk region and in the area of Samgori in the Pritbilissk region - which once again confirmed the high promise of the region between the Kura and the Iori.

The importance of the great success of the surveyors which is opening up a new petroleum region in the republic is, first of all, the fact that here liquid fuel was obtained from Eocene sediments having no small potential.

Secondly, the establishment of the commercially viable oil and gas-bearing region opens up great promise for oil and gas exploration in neighboring areas - in South Kakheta and Adzhinour - since they, along with the region between the Kura and Iori rivers, are part of the same oil and gas-bearing basin.

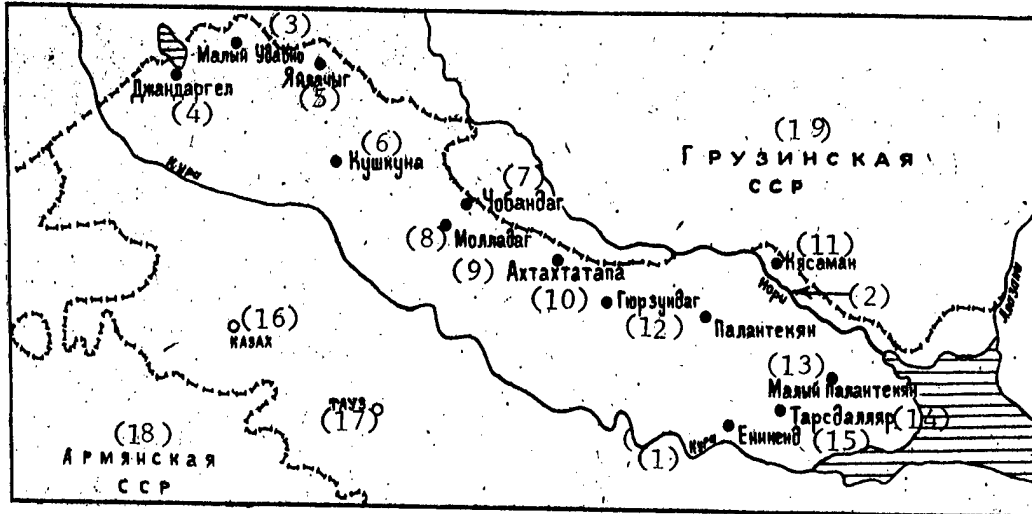

Locations of the principal areas between the Kura and Iori rivers which are promising for oil and gas exploration.

- (1)- Kura river, (2)- Iori river
 (3)- Malyy Udabno, (4)- Dzhandargel, (5)- Yaylachyg, (6)- Kushkuna
 (7)- Chobandag, (8)- Molladag, (9)- Akhtakhtatapa, (10)- Gyurzundag,
 (11)- Kyasaman, (12)- Palantekyan, (13)- Malyy palantekyan, (14)- Tarsdallyar,
 (15)- Yenikend, (16) Kazakh, (17)- Taus,
 (18)- Armenian SSR, (19)- Georgian SSR

All this, naturally, provides a complete basis for a broad return of exploration and suveying activities to the region between the Kura and Iori rivers. First priority assignments are: reinforcing the search for oil in the areas of Tarsdallyar and Gyurzundac, putting the drill to the areas of Palantekyan, Molladag, Akhtakhtatapa, western Gyurzundag and Kushkuna, resuming drilling work on the structure at Dzhandargel, and conducting parametric drilling in the areas of Yenikend, Malyy palantekyan, Kyasaman, Chobandag, Yaylachyg, and Malyy Udabno.

It is also necessary to continue seismic survey operations for finding new structures and for preparing to drill identified structures in the Paleogene-Mesozoic sediments in the eastern and western parts of the region and in the valley of the Kura. Identifying the character of the articulation of the tectonic structure between the Kura and the Iori with that in the Kirovabad and Adzhinour regions is an important problem for seismic surveyors.

There is no doubt that the successful accomplishment of these and several other tasks will permit converting western Azerbaijan into one of the promising oil producing regions of the republic and accelerating the rate of its development economically, culturally, and socially.

OIL AND GAS

TARSDALLYAR OIL FLOWS

Baku VYSHKA in Russian 6 Oct 83 p 1

[Article by special correspondent S. Garayev: "A Great Success for the Prospectors of the Depths" with the subtitle: "An Oil Deposit Discovered in Western Azerbaijan".]

[Text] The prolonged searches for reservoirs of oil in the region between the Kura and the Iori rivers have been crowned with success. A powerful flow of oil was obtained in the area of Tarsdallyar (in the Shamkorskiy Rayon) where foreman Fazil Mamedov's brigade from the Gobustan URB [Administration for Regional Drilling] put down exploratory well No. 1 and, for the first time in this region, happily uncovered sediments of the middle Eocene period. According to preliminary measurements, the well, with a depth of 2,882 meters, delivers 250-300 tons of pipeline-grade oil per day.

A 45 km long oil pipeline already is being laid at full speed to the promising new area. In the laying of it, in addition to the Azneftstroy [Azerbaijani Petroleum Construction] Trust, also taking part are construction brigades from the Muradkhanlineft NGDU [Muradkhanli Oil and Gas Producing Administration]. The geological service which already has taken over the exploitation of the well stock is the one that discovered it. It was decided to connect the pipeline to the Baku section of the former Batumi oil pipeline which provides for the transport of all production from deposits to the refinery.

"Now, in the Tarsdallyar area" says Avyaz Abdulayev, chief of the Gobustan URB, "two more drilling sites are being set up at an accelerated tempo. The drilling at one of them has been entrusted to Fazil Mamedov's brigade whose success inspires the whole collective of the Administration to new heights. We hope to obtain encouraging results from the first well being drilled in the area of Koyruk-Koylan which is situated several kilometers from the exploratory well at Tarsdallyar. Here, the brigade of foremen Rafael Khasayev and Mamedguseyn Dzhafarov has reached the 3,100 meter mark and, in all probability, already has uncovered Eocene sediments."

The oil prospectors are dedicating their success to the Day of the USSR Constitution and the 25th Year of the Movement Toward Communist Labor Relations.

9136
CSO:1822/80

OIL AND GAS

BULLA OIL PRODUCTION REPORT

Baku VYSHKA in Russian 16 Nov 83 p 1

[Report by O. Nechipurenko, Sangachaly-More: "The Caspian's Above-plan Oil", under the heading "Maximum Yield from Each Well"]

[Excerpts] Traveling snake-like far out into the sea to Bulla Island, the marine trestle makes an unexpected turn and here we are at our destination. Here in the second oil field, Mus Mamedaliyev's brigade, from the NGDU [Oil and Gas Producing Administration] imeni N. Narimanov, is carrying on the production of oil and gas and, in the third quarter of the year, they took first place in the competition which is under the slogan: "From every well - maximum output".

Success did not come to this collective by chance. The brigade produced about 4,000 tons of high quality oil from 12 wells having depths from 3,000 to 4,00 meters each. This is a great deal if account is taken that in the Sangachly only one, the seventh, stratum is being developed and already its resources are not what they were earlier.

Production has diminished by a factor of two or three in wells that at the beginning of exploitation produced 100-150 tons of "black gold". Every ton of oil above the plan comes with persistent daily labor. Only two wells are free-flowing here. The remainder are compressor-operated wells; the efficient operation of the compressors assures a uniform flow of gas.

The collective has achieved that there are practically no dead wells in the section. Recently they eliminated the sticking of pipes in well No. 60, and put well 254 back into operation, performing washover and reperforating the filter.

It should be noted that this is a comprehensive brigade. In addition to the wells, it also services the oil collection point to which fuel from the entire oil field is delivered. One of the collective's main goals is not to lose even a drop of oil.

9136

CSO: 1822/80

OIL AND GAS

DONETSK INSTITUTE HELPS DESIGN PIPELINES FROM URENGOY, YAMBURG

Kiev PRAVDA UKRAINY in Russian 12 Oct 83 p 1

[Interview with Boris Frolovich Leshchinskiy, deputy chief engineer of Yuzhniigiprogaz, by correspondent V. Petrenko (Donetsk): "Yamburg Accepts the Relay Baton"]

[Text] The river of gas that flows along steel-pipe channels from West Siberia's North to the center of the European portion of the USSR and to our country's western borders is becoming increasingly larger each year. Let us recall that this summer saw successful completion of the erection of the linear portion of the Urengoy-Pomary-Uzhgorod export trunk gas pipeline, the master designer of which was Yuzhniigiprogaz [Southern Branch of the Scientific-Research and Design Institute for the Design of Gas Pipelines and of Gas Industry Facilities], which is located in Donetsk (incidentally, it is observing its 50th anniversary this year). PRAVDA UKRAINY's correspondent asked the institute's deputy chief engineer B. F. Leshchinskiy to tell about what the collective is doing on the trunk gas pipeline complex and about what it is to do in the near term.

"During construction of the Urengoy-Uzhgorod gas pipeline," says Boris Frolovich, "we are executing designers' surveillance directly at the compressor stations and other facilities that are being erected: for our institute not only is the general designer of the arterial but it also has there a rather large contingent of its own--from the sources of the gas river, which starts in Urengoy, to Krasnoturinsk."

Leshchinskiy points to a chart which shows accurately, until year's end, when and where on the route the chief design engineers, the chief design developers, the chief specialists of various categories, the group supervisors and other staff workers will be going, and what they should be monitoring at the various structures on one of the largest construction projects of the 11th Five-Year Plan.

But the collective is not restricted to these concerns: Yuzhniigiprogaz has new and interesting jobs. Boris Frolovich lays on the table a map on which

have been outlined the "corridors" of the gas trunk pipelines, the arterial pipelines being designated by various colors--not only existing lines and those being laid but also those that are being designed and those that are still only being planned.

Here, let's say, are the first and second strands of the Urengoy-Tsentr gas pipeline, each about 3,000 kilometers long. Four USSR Ministry of Gas Industry institutes are designing them: Donetsk's Yuzhniigiprogez, Kiev's Soyuzgazproyekt [All-Union State Design Institute for the Survey and Design of Gas Industry Facilities], Leningrad's Giprospeetsgaz [State Institute for the Design of Trunk Pipelines and Special Construction for the USSR Ministry of Gas Industry], and Gorkiy's Giprogaztsentr [All-Union State Institute for the Design of Gas-Industry Facilities in the Central Economic Region].

The initial section, which fell to the lot of the Donetsk designers and is 1,260 kilometers in length, is especially complicated with respect to the environment. Nature has set therebefore people many different kinds of barriers, including frozen and subsident soils, buried ice strata and numerous swamps and rivers. The effectiveness and reliability of the gas pipeline's operation will depend greatly upon the correct choice of routing for the linear portion of the trunk line and of places for siting the compressor stations.

Yuzhniigiprogez has already issued to the builders all the working drawings on erection of the linear portion and the compressor stations of the first Urengoy-Tsentr strand, which will go to Yelets. Working drawings of the linear portion and of the compressor stations have also been prepared for the second strand of this arterial.

The Urengoy field, as is known, is not the only natural-gas storage in this region. Not far off are the fields of Medvezhye (its resources are already being worked on) and the Zapolyarnoye field. And north of Urengoy--Leshchinskiy points out on the map still another delineated and hatched oval--is the large Yamburg field, where the first Mingazprom [Ministry of Gas Industry] and USSR Minneftegazstroy [Ministry for the Construction of Petroleum and Gas Industry Enterprises] organizations have already arrived.

"Our institute," says Boris Frolovich, "is designing the facilities for building up the Yamburg gas field, including the whole infrastructure that will connect the wells with the UKPG--the integrated gas-treatment installation, and the collectors that lead from these installations to the terminal compressor station, as well as industrial bases, a housing settlement and other life-support systems of the future gas-recovering complex. From here--from Yamburg--the first strand of the new gas pipeline will stretch for about 3,150 kilometers, to Yelets. We have already issued working drawings for the amounts of construction planned for 1984 on the linear portion of the trunk pipeline, for the section assigned to Yuzhniigiprogez.

"The task for one important job--the second strand of the trunk pipeline, which should in the long term bring Siberian gas to the west, to Uzhgorod--has already been received. Taking part in the design work are five institutes, the already mentioned Yuzhniigiprogez, Soyuzgazproyekt, Giprospeetsgaz and

Giprogaztsentr, plus the All-Union Scientific-Research Institute for Natural Gas Transport (VNIPitransgaz), which is located in Kiev, among which portions of the route have been distributed. The crossings over the Ob and the Volga will be designed by Muscovites from Giprorrechtrans [State Institute for the Design of Inland Waterways].

"In order to provide for unification of design and technical solutions to all parts of the trunk pipeline," said B. F. Leshchinskiy in conclusion, "Yuzhnii-giprogaz, as the general designer, has undertaken to develop the basic principles for the forthcoming design of the linear portion, the compressor stations, the crossings over water obstacles, communications, transport and many other components of the design. Optimized computations have been made up, and the types of necessary gas-pumping units and similar machinery with which the new arterial gas pipeline will be equipped have been validated."

11409

CSO: 1822/88

OIL AND GAS

JOBS ON NORTHERN PIPELINES ADVERTISED

Moscow STROITEL'NAYA GAZETA in Russian 23 Oct 83 p 4

[Advertisement: "Wanted for Work"]

[Text] The Sakhalin State Scientific-Research and Design Institute for the Gas Industry wants:

Scientific staff workers and specialists who do or do not have scientific degrees, with great work experience in scientific-research subunits on the development of oil and gas fields;

technicians and production engineers for the recovery of oil, the drilling of wells, and the calculation of oil and gas reserves, for the post of senior scientific staff workers and subunit supervisors; and

design specialists for work in the oilfield-facility, construction-architectural, sanitary-engineering and electrical sections, for the posts of engineers, senior engineers, chief engineers and group supervisors.

A regional factor of 1.6 is added each 6 months, plus a northern increment in the amount of 10 to 80 percent (two later increments every other year). A relocation grant in the amount of two months' salary is paid, and travel by the staff worker and family members to the place of work is paid for.

Housing space will be allocated in accordance with a negotiated agreement.

Send an application, individual certificate of personnel records, autobiography, copy of diploma and medical certificate to: 694460, Sakhalinskaya Oblast, Okha, Ulitsa K. Marksa, 18, SakhalinNIPIneftegaz [Sakhalin State Scientific-Research and Design Institute for the Oil and Gas Industry] Personnel Section.

Departure for the place of work--when called.

Norilsktruboprovodstroy [Norilsk Pipeline Construction Trust] wants:

overhead electrical welders of the 5th and 6th categories, pipelayer fitters of the 4th to 6th categories, crane and pipelayer operators of the 5th and 6th classes, carpenters and plasterers of the 3d to 5th categories, and tinsmiths

of the 4th to 6th categories, as well as specialists for the posts of senior power engineer, chief welder, superintendents and foremen.

Workers are paid piece-rate wage plus bonus and time-rate plus bonus wage. The regional factor of 1.8 is credited each half year--the northern increment in the amount of 10 percent to 60 percent and later increments every other year.

Housing in mobile housing on right-of-way sections and in the Tukhard settlement is granted to those accepted for work.

Send application and a copy of the work book (in the case of workers) or the individual certificate of personnel records (in the case of engineers and technicians) to 663307, Norilsk, Ulitsa Vokzalnaya, 2-a, Norilsktruboprovodstroy Trust Personnel Section, telephone 2-86-35.

Departure for place of work after receiving letter notice.

The Orel Construction Administration wants:

at the large-panel housing-construction plant--molders of reinforced-concrete products, operators of overhead traveling cranes, machine-tool operators for the reinforcements shop, mechanics for repairing industrial equipment, electrical welders for KIPiA [monitoring and measuring instruments and automation], plumbers, gas-arc welders, electricians and compressor operators; and

engineers and specialists for the posts of department chiefs, shift foremen and mechanics and power workers for departments.

Allocation of rooms and of separate well-appointed apartments is guaranteed for those newly accepted this year and the first quarter of next year.

Write to: 302030, Orel, Ulitsa Moskovskaya, 13-a, Orel Construction Administration, Personnel Section.

Departure for work upon notice.

11409

CSO: 1822/88

OIL AND GAS

PREPARATION FOR WINTER AT AZERBAIJAN PLATFORMMAKING PLANT CRITICIZED

Baku VYSHKA in Russian 10 Nov 83 p 3

[Article by P. Kasumov, correspondent of the large-circulation newspaper KASPIY: "It Is Necessary to Prepare for Winter"]

[Text] An important time in preparation for the startup of an especially important five-year plan job--the Baku Plant for Manufacturing Support Parts for Deep-Water Stationary Foundations--has come. At the end of the year its first phase will have been introduced into operation. This means that the builders' main concerns will have to be the cold days of December. How have they prepared themselves for work in the winter?

In front of the plant's main building is a multitude of mobile field huts. They belong to workers of SU-71 [Construction Administration No 71], SU-72 and SU-73 of Trust No 7, the BMU [Baku Installing Administration] of Azsantekhmontazh [Azerbaijan Sanitary-Engineering Installing Trust] and other organizations.

Smoke is coming from among them. One would think: isn't there a fire? But it turned out that it is from the paper that is placed under the metal sheet with the cans on them that are being heated for dinner.

"What do you need the paper for?" I asked SU-73 worker Tamara Sysoyeva. "Isn't it easier to heat dinner on an electric plate?"

"What electric plate!" she waved her hand. "No electricity has been allocated us here."

"And there is nowhere to warm one's self?"

"None. Except that the paper..."

A container of water was at the worker's feet. T. Sysoyeva raised it up to her eyes and looked attentively at its contents.

"The debries have finally settled," she said, poured the water into the teapot and then placed it on the fire. She lamented: "The water is poor. We usually

get it from the wash stand at the square in front of the household-services center. There is no clean water close by."

On the wall at another household-services center, the one belonging to SU-74, is a high-powered electric stove, the use of which the firemen have categorically prohibited. It turned out that in some household-services centers there is electric power, but the electric wiring both outside and within the premises are in poor condition and require complete rehabilitation: many wires are hanging, and in some places they have been spliced incorrectly.

Obviously, the construction-organization supervisors and the construction-project staff have forgotten that it is necessary to get ready for winter, that it is necessary to create normal conditions for workers, without which successful work is unthinkable!

11409

CSO: 1822/88

OIL AND GAS

USE OF STEAM ENHANCES RECOVERY AT OIL MINE NEAR UKHTA

Riga SOVETSKAYA MOLODEZH' in Russian 12 Aug 83 p 4

[Article by A. Trutnev: "Into Mines for Oil"]

[Text] High-viscosity oil is being successfully mined at the Yarega field (Komi ASSR).

Everybody knows that oil is recovered by way of wells under the force of a high reservoir pressure and that it then will occasionally gush skyward for tens of meters. In the Yarega field, however, not far from Ukhta, an industrial center of the Komi autonomous republic, the pressure is low and the oil has the viscosity of glue. The wells which were drilled there were bringing it up literally a drop at a time.

It is some 200 meters altogether down to the productive formation from the surface, and the oil down there is of high quality. It can be used to make gasoline, kerosine, nonfreezing lubricating oils, valuable bitumens for paint and asphalt. If it won't come up, though, might it not be possible to go down there after it? There thus appeared our country's first oil mines.

Oilmen would now head down underground to work. They sank their wells directly over the formation itself. Application of this costly and laborious process, however, yielded increases in oil production of only 3-4 per cent. It was enough to drive them to despair.

But now if there were no way this "stubborn" oil wanted to come up, then it was going to have to flow downward. Oil workers built passageways, corridors and entire cavernous rooms down below the producing horizon. They believed the oil was then going to flow like a river. The sandstone saturated with the precious product, however, did not want to give it up. Yields, which had appeared to be on the verge of increases, again turned into losses.

The problem was ultimately solved when the oilmen turned to the method of thermally enhanced recovery. Under normal conditions the viscosity of the "heavy" oil in the reservoir will reach as high as 20,000 centipoise. When the oil is heated to 100° Celsius this figure drops almost to that of normal oil—30 centipoise. What is more, the oil flows much more freely in heated form. A formation saturated with high-viscosity oil, it is true, is virtually impermeable by water. To employ high pressure to pump hot water into it will be impossible in this instance:

there are many fissures in the sandstone the water washes through and simply washes out. Steam, however, has been shown to be able to penetrate the pores in a formation and heat the oil they contain.

This innovation has yielded gains beyond all expectations: some 30 per cent of our high-viscosity can now be recovered by this method. Production of high-viscosity oil has accordingly risen 15-fold.

...I went down into one of these mines and immediately found myself in front of an oil-bearing formation. The sandstone, saturated with oil, has a shiny, oily look and gleams and sparkles in the lamplight. It's getting hotter now. The steam running through pipes laid right through here is heating up the air. I go down deeper now. Down here, now, I don't see any more gooey drops oozing out of the walls, but rather fast-flowing rivulets racing down, merging into streams, which then flow rapidly into a sump in the center of the working. Then from this still, black lake powerful pumps drive the oil up toward the surface.

This is the method being used in oil production operations at all three mines at the Yarega field. Plans call for the production of 450,000 tons of this precious raw material during 1983.

8963

CSO: 1822/16

OIL AND GAS

SHORTAGE OF COMPRESSED OXYGEN FOR OFFSHORE DRILLING RIG CONSTRUCTION NOTED

Baku VYSHKA in Russian 31 Aug 83 p 2

[Article by O. Nechipurenko: "And if the Oxygen Runs Out...."]

[Text] Could a painter begin a job without any paint? Or a baker bake bread without flour and yeast? As becomes clear from their letters to the editor, however, engineers of the Kaspormoburstroy platform trust, who build the steel platform islands used in drilling wells out in the oil and gas fields of the Caspian, are now finding themselves in just a situation.

..."Our work depends primarily upon timely supplies of the compressed oxygen we need to weld and cut metal," write some of our leading construction and installation brigade leaders, including V. Zlagodukhov, T. Ismaylov, A. Ibragimov and others (there are 10 signatures altogether). "But the service we're getting is absolutely miserable. There was one stretch during which we had to go to sea five days in a row without a single bottle of oxygen. And the result is disruptions in the plan for bringing offshore platforms on stream."

It should be pointed out here that this isn't the first time the construction and installation workers of Kaspormoburstroy have drawn attention to this problem. Speaking at a gathering of competition winners held by the Kasporneftegazprom Production Association to review the accomplishments of the past year, V. Zlagodukhov, a construction and installation brigade leader, referred to this very situation. But as we can see, things haven't changed.

The day we arrived at the Kaspormoburstroy platform trust, the work here was virtually paralyzed because of a lack of oxygen. Workers who had gathered in their day room were playing lotto.

L. Kulichenko, one of those who had signed the letter to the editor, had already left that morning to get some oxygen. And where haven't these offshore platform builders been getting their oxygen these days: from enterprises of the Soyuzneftemash and Kasporsudoremont associations, from the chemists at Sumgait and from other organizations and departments. But they still aren't getting all they need. A. Azimov, director of the Machine-Building Plant imeni October Revolution, which now is a component of the Kaspormoburstroy platform trust, told us that he, too, starts his working day looking for oxygen.

"Today, for example, the Kirov and Paris Commune plants saved us, but I don't know what's going to happen tomorrow," he says.

In a word, the facts set forth in the letter to the editor have been fully confirmed.

Let us point out in passing, too, that this trust is not the only organization whose work is suffering because of shortages of oxygen. K. Mukhtarov, deputy director of the Azmorneftestroy trust and secretary of his party organization, told us about a situation which had arisen in the middle of work on the installation of a boiler for a new housing development in Lok-Batan settlement.

"The specialists from Kavkazenergomontazh are getting ready to abandon the job because they don't have any oxygen, and we can't supply them with it," he says. "And then, comes the winter, we're not going to be able to heat these new buildings."

A few years back, VYSHKA was already calling attention to interruptions in supplies of compressed oxygen to our oilmen. The Sverdlov oxygen and acetylene plant, which is a component of the Azneft' association, was then supplying a large number of enterprises in Baku and elsewhere with compressed gas. But because its equipment was old and worn out it was unable to satisfy their requirements completely.

Since then, as we say, a lot of water has gone under the bridge. From what has been said it is clear that a number of enterprises have acquired their own facilities for manufacturing compressed oxygen. The republic plans to build a major compressed gas-producing complex at Sumgait.

The offshore oilmen have a facility like this, too. And if they would use it as efficiently as they should, I don't think the editor would be getting any letters from offshore platform builders. The fact is that right next door to the Kaspmburstroy platform trust the Kaspneftegazflot association's Ship Repair Works imeni 21st Congress of the CPSU produces oxygen in quantities every day which by far exceed the requirements of this enterprise. The surplus gas here is simply discharged into the atmosphere. To make it possible to use all of it would require only the laying of a pipeline a few hundred meters long. The management of the trust should undertake this project, that is, assign the task of planning and designing the line to Gipromorneftegaz. But as we were told by S. Khanbekov, chief of the stationary offshore platform department of the Kasporneftegazprom all-Union production association, nothing in this direction has yet been done.

This line, of course, is by no means going to solve all the problems involved in supplying the offshore oilmen with the oxygen they need. The assembly site for the construction of stationary offshore deep-water platforms, which, according to socialist obligations undertaken by workers of the Azerbaijan SSR, is to be completed in 1983, is accordingly scheduled to be provided with two compressed oxygen-producing facilities with a capacity of 150 cubic meters per hour. As it turns out, however, this is far from being the last of the problems to be solved here. A. Okonenko, deputy director of the Kaspneftegazstroy trust, told us that it is still not known who is going to put these facilities in. So the obstacles standing in the way of efforts to supply these offshore platform builders with

the oxygen they need are many. To remove them is the joint responsibility of the management of the platform trust and the Kasporneftegazprom all-Union production association.

8963

CSO: 1822/16

OIL AND GAS

IMPROVEMENT IN RECOVERY METHODS, UTILIZATION OF CONDENSATE URGED

Moscow IZVESTIYA in Russian 9 Sep 83 p 2

[Article by IZVESTIYA correspondent Yu. Perepletkin: "'Inconvenient' Condensate: Need to Utilize Precious Raw Material Reserves More Fully"; in the column: "Notice to Ministries and Departments"]

[Text] Much has been written about the celebrated deposits of oil and gas in Western Siberia. These deposits are being developed at a rapid pace by means of the most advanced technologies and taking account of the latest scientific recommendations. It is enough to recall that by the end of the five-year-plan period the country will be getting a substantial proportion of the petroleum and natural gas produced nationwide from the fields at Tyumen'. Workers here are laboring continuously to recover millions of tons of oil and billions of cubic meters of gas.

But there is another valuable raw material contained within Siberia's producing formations—condensate. As early as 1964, when the Novoportovskoye field was discovered, geologists found together with the natural gas an inflow of a transparent, slightly yellowish liquid which smelled very much like gasoline. Ever since then, new deposits have increasingly come to be referred to as gas condensate or oil and gas condensate deposits. And now dozens of deposits have been discovered which contain this raw hydrocarbon, whose composition has assigned it a place on the uncertain boundary between gas and liquid.

As an example, let's look at the largest and best-known gas condensate deposit, the Urengoy. Showing me a cut-away diagram of a unique underground storage area, N. Kulakhmetov, deputy director for science of the Western Siberian Scientific Research Institute of Petroleum Geological Exploration (ZapsibNIGNI), pointed out that "there are more than twenty producing formations here. We're working the upper Cenomanian horizons now. This is where the blue fuel starts on its journey by main pipeline for Moscow, Petrovsk, Novoposkov and the western frontier of the USSR. The Senomanskiy gas contains only insignificant amounts of condensate. But now the deeper horizons, the ones we refer to as the Valanzhinskiye horizons, which lie between 2500 and 3000 meters down, are literally saturated with 'white oil.' Here it accounts for some 85 per cent of the reserves in the formation. The condensate we've found is not by any means, of course, all there is down there, but I'm sure the quantities the geologists have already discovered are going to make it possible to develop a major independent industrial facility

whose purpose will be to recover and fully utilize this precious raw material. It is, after all, our future gasoline, kerosine and diesel fuel."

Now you would think that the task involved here would be a clear-cut business: there is enormous raw-material wealth down there below our feet, so we recover it and use it; the problem is, though, that it's not all that easy a thing to get the condensate out. In the first place, you have to drill wells which are considerably deeper than the ones you ordinarily drill. Second, the recovery of unstable hydrocarbons, to bring them to the surface, requires the strict maintenance of a specific relationship between temperature and pressure: the least deviation from these rigid requirements will see the condensate change its physical composition and be lost irretrievably inside the Earth. All this requires the application of a special technology, one not yet fully developed, and very expensive special equipment.

And there's more. After you've succeeded in recovering the condensate from the Urengoy depths, it will still require a good deal of handling and processing. Some of its components have to be separated out at a complex stabilization facility (it is only now in the development stage), while the remaining raw material will go by condensate pipeline (which is still going to have to be built) from Urengoy to Surgut, where it will be more thoroughly refined (this facility, too, is only now being built). Even after all this processing, however, there will still remain a large percentage of liquid hydrocarbon fractions. It is proposed to pump them together with the petroleum through the existing Surgut-Polotsk pipeline.

"This isn't good economic management!" V. Nelepchenko, deputy director of gas transportation and treatment of the Tyumen' Natural Gas Institute (TyumenNIIgiprogaz), declared heatedly during a meeting. "Here we're going to be putting an unnecessary load on the pipeline sending out virtually completely refined gasoline and diesel fuel, while at the same time we're going to have trains carrying fuel in. The condensate should be refined on site."

As I listened to Vitaliy Mikhaylovich I recalled a visit to Urengoy a few years ago on the occasion of tests of an experimental facility which was about to be put into operation to make solar oil and gasoline out of the condensate locally. The test was a success. This simple installation is now refining out some 12,000 tons of "white oil" each year and meeting almost 20 per cent of the gas producers' diesel fuel requirements. It is also turning out gasoline, low-quality gasoline to be sure, but by mixing it with higher-grade products brought from the outside, among other methods, these northerners, as they say, will bring the overall mix up to snuff.

I spoke on the same occasion with V. Denisenko, chief engineer of the Urengoy-gasodobycha association, and he spoke enthusiastically of the fact that the success of this modest facility would be followed by the planning and design of a major enterprise which would be refining some 350,000 tons of condensate each year. It was later realized at some level, however, that it would be to no advantage to build a facility like this—it wouldn't, it was seen, solve the problem; it was necessary to build and operate on a much larger scale, so this somewhat primitive facility has remained the only one of its kind. The problem is that condensate is not used anywhere these days except at that particular operation. It is true that plans have been made to modernize it, or, put simply, to add on another facility just like it, thereby doubling its capacity. But this, of course, would be only drops in the bucket....

Scientists from the ZapsibNIGNI and TyumenNIIgiprokaz institutes and experts from Glavtyumengeologiya and the Tyumengazprom all-Union production association have put their views to me concerning the situation which has now emerged. There were slight differences in their opinions, which was, of course, only to be expected in the case of people representing different organizational points of view, but on one thing they were all agreed: any solution to the problem of exploiting this most valuable chemical and energy raw material has been unduly delayed.

Let's take a pencil and do a few elementary calculations. Ten or so wells have now been drilled down to the Valanginian horizons at Urengoy, and plans currently call for this number to grow to forty. This is inevitable, what with the fact that already next year 2 million tons are scheduled for recovery and 4 million for 1985. But wells are now being conserved: there's no place to refine the raw material.

At the same time, our gas producers are engaged in an intensive effort to deliver ordinary dry gas from the Cenomanian deposits to the main pipeline system. Minneftegazstroy [Ministry of Petroleum and Gas Industry Construction] specialists are now building facilities, enormous plants in the tundra, to treat and dehydrate it. Current manpower levels are permitting them to put up a couple of plants a year now. That is, they will, with some difficulty, be able within this time frame to do some 50-60 million rubles' worth of work.

But now, in addition to their ongoing responsibilities, they have also been charged with the additional task of quickly putting up the elaborate complex for a condensate stabilization facility, otherwise the wells will have to remain inactive. According to the roughest of data, this is a volume of construction and installation work which is about three times as much as the Minneftegazstroy organizations now here can do in a year.

It had been hoped that manpower would be available from Minmontazhspetsstroy [Ministry of Installation and Special Construction Work]. Specialists within this ministry, however, are now working on stabilization columns and tank farms only; they heat-insulate equipment, no insignificant contribution. And so it will be in the future.

Work has now begun on the Urengoy-Surgut pipeline. It is possible that the pipeline workers will be able to complete their assignment on time—they definitely know their job. As far as the Surgut condensate refinery is concerned, however, the facility the pipeline is supposed to deliver the condensate to, as one person put it, "the thing hasn't gotten off the ground yet."

A Gosplan USSR interdepartmental territorial commission has been set up and activated in Tyumen' to deal with questions associated with the development of the Western Siberian oil and gas complex. We met with N. Denisenko, one of the senior officials in the oil and gas industry planning division. That's right, the very same expert from Urengoy who knows the condensate problem inside and out.

"You want to know what I think about it?" he replied in response. "I personally see events taking one of two possible courses. If we look only at the possibilities open to our builders today, and then take into account the difficult and critical tasks we face of increasing production of the Cenomanian gas, then it would be better not to try to go after the condensate. If, on the other hand,

we want to forge ahead anyway with a plan to develop these deposits of 'white oil' which are so essential to our national economy, then we should pursue this course under one condition only: that we pursue it with large forces adequate to the mission and that this be a joint undertaking."

Very precisely put. It would now appear that to translate these words into action the interdepartmental commission itself should propose to the various ministries involved that they take those specific steps which would make it possible for all together to arrive at a solution of this acute problem. Time marches inexorably on. Each passing day brings us closer to the date planned for hundreds, thousands, millions of tons of "white oil" to be made available for service to the motherland. Condensate, of course, is something of a tough nut to crack; it's not easy stuff to work with, involving as it does a process by no means free of problems. We can't back away from it, though. The fact is, after all, that "Basic Directions of the Economic and Social Development of the USSR for the Years 1981-1985 and the Period Extending to 1990" refers very clearly to the need to increase our production of gas condensate and to make fuller use of it and that this is given an entire line to itself there.

8963

CSO: 1822/16

OIL AND GAS

BRIEFS

SAMANTEPE GASFIELD HELICOPTER TRANSPORT--Chardzhou (Turkmenskaya SSR), 22 Oct-- Delivery of the basic drill rigs and equipment to Samantepe--a promising gas-field in eastern Turkmenistan--has been completed. Most of the equipment was delivered by the Kirpichli-Samantepe aerial bridge, which was organized by local helicopter pilots. This type of transport was not chosen accidentally: the distance between the gas fields is great--more than 300 kilometers, and the turbulent Amu-Darya separates them. Installations and equipment are hauled in precise fashion, enabling them to go straight to the drilling sites. [TASS] [Text] [Moscow PRAVDA in Russian 23 Oct 83 p 1] 11409

EKIZ-AK GASFIELD STARTS PRODUCING--Krasnovodsk--The flow of gas that enters the Central Asia-Tsentr trunk pipeline has increased: the Ekiz-AK field has begun to operate. This one, like other gasfields of Krasnovodsk Oblast, is not a large facility. When it reaches design capacity next year, 150 million cubic meters of gas will be recovered here each year. But a solicitous and zealous attitude toward existing resources, a combining of the capacity of small fields and the use of casing-head gas from oilfields will enable billions of cubic meters of raw material to be obtained annually. [Text] [Moscow STROITEL'NAYA GAZETA in Russian 23 Oct 83 p 1] 11409

DEEP CAUCASIAN GAS WELL--Fuel has been obtained at the Bulla-Offshore field from a well that opened up a formation at a depth of 6,130 meters. One of the deepest wells on the Caspian Sea, it also has proved to be one of the most productive. Its daily flow rate is 150 tons of gas condensate and 700,000 cubic meters of gas. The gasfield workers had to exert no little effort to restrain the gas blowout and to isolate the formation water, and they fulfilled honorably the socialist commitments they adopted in honor of the 66th anniversary of the Great October. It is proposed to drill 40 more boreholes at the Bulla-Offshore field. In order to transport the raw material, an 84-kilometer pipeline has been built that will unite the island oilfield with the gas-treatment plant on shore. [Text] [Moscow PRAVDA in Russian 29 Oct 83 p 2] 11409

KIRGHIZIA OIL EXPLORATION--Kochkor-Ata Settlement--In competing for a worthy greeting to the 25th anniversary of the Movement for a Communist Attitude Toward Work, the oil-exploration expedition collective of Kirgizneft' [Kirghizia Oil Production Association] completed a month ahead of schedule the plan for drilling cored holes for the first 10 months of the year. Foreman

T. Cheremisin's brigade gained primacy in the anniversary competition. Its cost per meter for making hole was 24 rubles below the plan's cost. Savings since the start of the five-year plan have exceeded 300,000 rubles. These days the brigade is drilling hole No 3 with a designed depth of 1,600 meters. Shock-worker drillers of communist labor N. Tazhibayev, A. Kurmanaliyev, Yu. Tregubov and V. Bychko and diesel operators Yu. Skopenko and I. Prokof'yev are carrying on the drive with precision. [P. Khramov] [Text] [Frunze SOVETSKAYA KIRGIZIYA in Russian 13 Oct 83 p 1] 11409

SAKHALIN SHELF PETROLEUM EXPLORATION--Exploration of the shelf off the north-eastern shores of Sakhalin for oil, gas and condensate fields continues. The Far Eastern Offshore Deep-Drilling Oil and Gas Exploration Expedition is performing the study. The researchers have not been encouraged by good weather during the preholiday period--the Okhotsk Sea has been storming--but their spirits are high: on the eve of the Great October the work has been going on well ahead of schedule. The expedition is now completing exploration of the Odoptinskoye Oilfield--holes more than 2,000 meters deep have been drilled here. The work is being done with the jack-up floating drill rig "Okha," and the motorship "Lyutoga" has been doing the towing and has been supplying the "Okha" with the necessary materials. In the photographs [not reproduced]: top--N. Ivashov, captain, and V. Chumachenko, first-mate, of the motorship "Lyutoga" are supervising the holiday drive; left--the "Lyutoga" with cargo for the "Okha" rig. [TASS] [Text] [Moscow SOTSIALISTICHESKAYA INDUSTRIYA in Russian 4 Nov 83 p 1] 11409

DANILOVSKY BRANCH GAS PIPELINES--Danilovka (Volgograd Oblast)--On the eve of the Great October holiday local residents received a nice gift from the builders. A new 35-kilometer gas pipeline was turned over for operation. Danilovskiy Rayon has become the 21st of the oblast's 33 rayons to get the natural "blue fuel." In the past 3 years Alekseyevskiy, Podtelkovskiy, Nekhayevskiy, Uryupinskiy and Olkhovskiy Rayons have received gas from underground stores. [A. Yuzhilkin] [Text] [Moscow SEL'SKAYA ZHIZN' in Russian 30 Oct 83 p 1] 11409

URENGOY-TSENTR-1 GAS PIPELINE--The record work pace achieved during erection of the Urengoy-Pomary-Uzhgorod gas pipeline has been excelled during construction of the Urengoy-Tsentr-1 pipeline. Yesterday the 1,000th kilometer of pipe on this route was laid in the ditch. A third of the entire length of the new fuel artery, which will reach the town of Yelets, in Lipetsk Oblast, has been laid. The Main Control Administration of the Ministry of Construction of Petroleum and Gas Industry Enterprises has reported on the new labor success of the right-of-way workers, which was achieved on the eve of the 66th anniversary of the Great October. The Urengoy-Tsentr-1 gas pipeline is the fifth line erected from West Siberia during the current five-year plan. Construction of the four preceding arterials--to Moscow, Petrovsk, Novopskov and Uzhgorod--were completed ahead of schedule. The pace that the new construction project has reached is a meaningful guarantee that this fuel artery also will be ready ahead of time. [Text] [Moscow PRAVDA in Russian 28 Oct p1] 11409

KAZAN-PRODUCED PIPE CARRIER--Kazan--The 42-meter PV-204 pipelength carrier, which has a KRAZ truck chassis, is being produced at a local plant. This year

the trunk gas pipeline builders will receive more than 150 of the powerful machines from here. The pipelength carriers, which can travel off the road, have proved themselves well on the gas and oil pipeline rights-of-way. The local brand of machine has been displayed at the VDNKh SSSR [USSR Exhibition of Achievements of the National Economy], and in December last year it was awarded the State Emblem of Quality. The branch has also mastered the output of automatic grippers for large-diameter pipe. [Text] [Moscow SEL'SKAYA ZHIZN' in Russian 28 Oct 83 p 1] 11409

BARSA-GELMES ON GASLIFT SYSTEM--Several dozen wells of the Barsa-Gelmes field have been connected to the unified gaslift system. Gas from Kotup-Tepe will now be pumped into the deep formations of the wells in order to increase the recovery of "black gold" and to stabilize the wells' operation at the prescribed rates. The unified gaslift system has been converted to the mechanized method of well operation. More than half a million cubic meters of gas are sent here daily. Introduction of the new system has enabled oil recovery at a large group of wells to be stabilized. [Z. Rzayev] [Text] [Ashkhabad TURKMENSKAYA ISKRA in Russian 28 Sep 83 p 1] 11409

BRIDGE TO ARCTIC FIELDS--Usinsk (Komi ASSR)--A bridge across the Kolva River has opened the road to Arctic oil and gas fields. The concrete passage, which was accepted for operation with an "excellent" evaluation, has reliably connected Usinsk with the temporary settlements of the oil explorers and construction workers. An access highway has been laid from here across the swampy forested tundra. Now the north's prolonged bad-road season will not affect continuous supply to the pioneers. The new bridge will enable acceleration of the work on building up the Severovozeyskoye and Kharyaginskoye fields, on the basis of which a new oil-recovery facility is being created. The oilfield workers are making themselves soundly at home in the Arctic. The urban-type settlement of Usinsk is growing. Schools and kindergartens have been built. From here the rotating duty brigades of builders and recovery operators will ride out in buses to work, to tend the new oilfield facility. Leningrad bridgebuilders and Perm roadbuilders have been helping to create a reliable transport system for the northerners. [Text] [Moscow SEL'SKAYA ZHIZN' in Russian 28 Oct 83 p 1] 11409

SWAMP-TRAVELING HAULER--Sysert, Sverdlovsk Oblast--The route of the Tyumen swamp traveler lies along the taiga swamps that are most difficult of passage. This vehicle, made at the Sysertgazmash plant, has successfully passed its tests and is ready for shipment to a permanent work site in Siberia's oil-bearing regions. Here the swamp traveler is one of the main types of transport. Such a vehicle can take a 36-ton load aboard. When designing it, the enterprise's specialists considered the desires of the ecologists: even when carrying a load, the all-terrain vehicle disturbs the vegetative cover practically not at all. The weight is distributed uniformly on four wide tracks, reducing the pressure per square centimeter of soil to 0.3 kilogram. This is much less than for a pedestrian. For the next year, the enterprise's collective has planned to master the output of specialized swamp traveling vehicles--cement carriers, cement mixers and refuelers. The construction of a specialized department for this purpose is now being completed at the enterprise. [N. Potapova (TASS correspondent)] [Text] [Moscow SOTSIALISTICHESKAYA INDUSTRIYA in Russian 12 Oct 83 p 2] 11409

NEW CASPIAN OFFSHORE FINDS--Baku, 16 Oct--Caspian wells at the Field imeni 28 Aprelya and the Bulla-Offshore field have yielded capacious flows of crude--300 tons each per day--almost simultaneously. This was a great service by the collective of the Office for Validating Exploration Wells, under oil-industry veteran Mirza Bedirkhanov. True masters of their business are working here. It happens that whether there will be drilling or not depends upon the actions of the validators. But a majority of the brigade's trials, which, incidentally, are always performed ahead of schedule, are completed with a high flow-rate gusher. Since the start of the year, the office's collective has tested and turned over 15 exploration and production wells, thereby carrying out the annual plan 3 months ahead of schedule. A commitment to turn over another three wells by the end of the year has been adopted. [L. Tairov] [Text] [Moscow PRAVDA in Russian 17 Oct 83 p 1] 11409

NEW OILFIELD BULLDOZER-CRANE--A special tractor of unusual design appeared at well No 212 at Pirsagat in the summer of last year. A bulldozer blade was mounted on the well-known T-100M tractor and crane. This bulldozer-crane fulfills successfully the functions of both a bulldozer and an erecting crane. In the country's oil industry, ordinarily a tractor with an erecting crane or a bulldozer based upon a tractor is used. Both types of machinery happen to be needed at exploration wells when conducting preparatory and direct operations. Therefore, two tractors--one with a crane and one a tractor-bulldozer--are allocated to each drill rig. The design for the bulldozer-crane, which was worked out by the Gobustan Industrial-Transport Administration of Azneft' [Azerbaijan Oil Production Association] engineers Sh. Shakhmaliyev and A. Osmanov, will enable each drill rig to employ the services of only one special tractor instead of two. This cuts current expenditures for equipment operation, repair and upkeep almost in half. The economic effectiveness of one bulldozer-crane is about 15,000 rubles. [M. Mamedov, chief of the transport section of Azneft' Association] [Text] [Baku VYSHKA in Russian 13 Oct 83 p 2] 11409

TEBUK OILFIELD SURPASSES GOAL--Ukhta--The collective of Oilfield Facility No 1 of Tebukneft' [Tebuk Oil Production Administration], which is under Communist V. Kirilenko, recovered 30,000 tons of crude above the goal. The task for the first 10 months of the year was completed ahead of schedule. This success, which was aided mainly by the effective use of the well inventory, was achieved in collaboration with the underground-repair brigades. [V. Krukovskiy] [Text] [Moscow SOTSIALISTICHESKAYA INDUSTRIYA in Russian 25 Oct 83 p 1] 11409

GUSHER IN AKPATLAUKH AREA--Nebit-Dag--Not so long ago drilling brigades of the Order of Lenin production association Turkmenneft' [Turkmen Oil Production Association] moved to the new Akpatlaukh area. An oil gusher has already been struck at well No 4 at a depth of 3,325 meters. It was drilled by the brigade of drilling foreman Durdy Mamedov, and Teke Tekayev's brigade has been charged with operating it. "Oilfield geophysical research results did not enable this target to be mastered," said chief geologist Nury Khancharov of the Okaremskiy Drilling Administration. "However, we persisted, and, as you see, our forecasts have been confirmed--there is oil." The drillers are dedicating their success to the 66th anniversary of the Great October Socialist Revolution. [F. Zhukoborskiy, senior scientific staff worker of TurkmenNIPIneft' [Turkmen

State Scientific-Research and Design Institute for the Oil Industry] and candidate of geologico-mineralogical sciences] [Text] [Ashkhabad TURKMENSKAYA ISKRA in Russian 29 Oct 83 p 1] 11409

GAS PIPELINE TO KISHINEV--Kishinev--The first kilometers of pipe for the Kishinev-Rybnitsa trunk gas pipeline, which is being laid down by Ukr-zapadneftegazstroy [Trust for the Construction of Oil and Gas Industry Facilities in the Western Ukraine] specialists, have been welded. "The line is more than 100 kilometers long," says V. Yarmakov, chief engineer of the republic's production association Moldgaz. "The gas pipeline passes through the lands of several rayons in the direction of Rezina, and there it is rerouted over the Dnestr. The terminal point is the Moldavian Metallurgical Plant. Next year, as is well known, will be its startup year. By that time the new industrial construction project will receive inexpensive gas. It will go also into the homes of rural residents and will heat livestock departments, hothouses and workshops. The republic's gas grid nowadays is more than 1,200 kilometers long. By the end of the five-year plan it will be extended almost 200 more kilometers. Since introduction into operation of the Razdelnaya-Izmail trunk gas pipeline, conversion to gas in the southern portion of Moldavia has been accelerated. Lines for the blue flame have appeared in Kaushany and Suvorovo, and now it is the turn of Kagulskiy, Bessarabskiy, Chimishliyskiy and other rayons. The Kishinev-Rybnitsa line, which has its start at Novyye Chekany, is the longest of the branch lines from the gas arterial. [V. Ivanov] [Text] [Kishinev SOVETSKAYA MOLDAVIYA in Russian 25 Oct 83 p 4] 11409

DEEP CASPIAN OIL PRODUCER--The millionth ton of crude has been recovered at the Field imeni 28 Aprelya, the deepest in the Caspian. It has also proved to be the highest flowing: this million tons came from only six wells, the daily productivity of each of which is 200 or more tons of the valuable raw material. Four bores have been drilled at the fields from a stationary platform that has been installed at an 84-meter depth, for the first time in the Caspian. Then the underground explorers moved still deeper, assembling an island above a 100-meter depth of water. And a platform whose steel legs have pierced a 112-meter depth is now being erected. The offshore facility at the Field imeni 28 Aprelya is serving as a testing ground for new drilling equipment. Each stage of depth means different design and engineering solutions and persistence in overcoming nature's opposition. While the second platform from which two wells are drilled simultaneously is designed for 12 bores, with the third it will be possible to drill twice as many. The field is being developed also from mobile platforms. [TASS] [Moscow SOTSIALISTICHESKAYA INDUSTRIYA in Russian 21 Sep 83 p 1] 11409

CSO: 1822/88

COAL

UDC 622.232.83

NEW MINING EQUIPMENT PRODUCED AT GORLOVKA PLANT

Kiev UGOL' UKRAINY in Russian No 9, Sep 83 pp 1-4

[Article By A. A. Chichkan, plant director: "Machine Builders at Plant imeni Kirov in Gorlovka Are Working for Miners in the 11th Five-Year Plan"]

[Text] The changes which have taken place in mining operations in recent years have increased the demands made upon coal extraction machinery and have made necessary its improvement and increases in its reliability and longevity. The Machine Building Plant imeni Kirov in Gorlovka is the main producer of mucking machines. During the first 2 years of the 11th Five-Year Plan it practically completely modernized its output composition, having considerably improved its quality parameters and increased the production of machines meeting contemporary technical standards.

During 1981-1982 it mastered the series production of six new items: the K-103, Poisk-2, 1GSh-68B, and 2KSh-3 narrow reach combines, the Strela-77 drill and the ZLP safety winch. It modernized six items: the MK-67m, 1K-101u, 2k-52mu, KSh-1kgu and the Kirovets-2k mucking machines, the 1AShchM conveyor cutter and removed seven obsolete items from production.

The upgrading of production made it possible to increase the share of machinery exceeding or meeting the standards of the better foreign models and of modernized machines from 26 percent of total volume in 1980 to 64.5 percent in 1983. Eight items were given the high quality category (18.7 percent of total production in 1983, compared to 5 percent in 1980). The average service life of mucking combines prior to capital repairs increased by 11.5 percent (from 222,500 tons to 248,000 tons) while average power increased by 20.2 percent (from 135.7 to 162.1 kWt).

The K-103 narrow reach mucking combine is intended for coal extraction from seams up to 0.6 m thick using a mechanized 1M-103 and individual supports. It works with a suspended advance system and a conveyor system with non-niche self-notching. The combine has a number of advantages over contemporary coal combines from the FRG, France and England: short length, an advance system suspended in the drift, simplifying construction and improving technical servicing conditions; improved design of the working unit drive, including an integral housing and two electric motors with shafts parallel to the auger shafts. Combine reliability and longevity is increased, it is high powered

(224 kWt) and radio controlled; the mobility of the roof support system increases the range of seam thickness which can be worked and eliminates wedging in the conveyor, it doesn't have bevel gearing, the most breakdown prone component in coal combines, requiring readjustment, etc. For the extraction of steep seams 0.36 to 0.75 m thick, in 1982 the plant mastered the series production of the Poisk-2 combines. Its design provides for extraction using a one-sided bottom to top scheme, the gravity flow of coal from the working space on a diagonal face, the use of mechanized or individual supports and the remote control of the combine and traction winch. The Poisk-2's parameters meet contemporary technical standards. The unit housing is 280 mm high. The combine is equipped with 330 or 400 mm diameter drums.

The use of the Poisk-2 to extract very thin seams will considerably expand the region for mechanized extraction of thick, explosion prone seams by Temp-1 or tunnelling units. The Poisk-2 is high powered (60 kWt in pneumatic or electrical versions) and has a simple transmission due to the installation of two motors with shafts parallel to the drum shafts. The design makes provisions for remote control from the drift and for warning alarms.

The Gorlovka plant is devoting much attention to improving the reliability and longevity of the 1GSh-68 and 1GSh-68E combines. Their power has been increased from 250 kWt to 264 kWt, improving all techno-economic indicators of combine operation. There are reductions in overall unit labor intensity of technical servicing and current repairs. An improved spray device has been introduced, its use will reduce pressure losses in sprayers. Combine part and component reliability and longevity have been improved and the machines are more easily repaired. The 1GSh-68 combine is the world's only model with a conveyor frame housing. Its kinematic layout makes provisions for operating two electric motors on one shaft to ensure the complete use of installed power (equal to 400 kWt on separate drive) and their even loading. Distinguishing features of the 1GSh-68 are electrical equipment designed for 1140 V and electric motors of up to 160 kWt. The 1GSh-68 and 1GSh-68E combines are equal to the best foreign models, and are even better with respect to a number of indicators (drive power, traction capacity, mechanization of coal extraction at terminal sections of longwalls). In 1982 the combines were awarded the higher quality category.

The use of the 1GSh-68 at the Trudovskaya Mine (Donetskugol') in 1980-1982 made it possible for the brigade of Hero of Socialist Labor A. D. Polishchuk to extract 1 million and more tons of coal annually. The million ton mark was passed with the use of the 1GSh-68 by the brigades led by M. P. Chikh (Rostovugol'), K. S. Markelov (Gukovugol'), and V. I. Ignat'yev (Krasnoarmeyskugol'). A 1GSh-68 at the Raspadskaya Mine in the Kusbass extracted 1.3 million tons of coal without major repairs.

The basic direction in the improvement of advance mechanisms is the use of non-chain advance systems (NAS). This reduces dynamic loadings on operating unit drives and assists in the effective use of installed capacity. In addition, it improves work safety through the elimination of chains and safety restraining winches. The production of the 2GSh-68B and 2KSh-3 combines has been mastered. These have non-chain advance mechanisms. Their

operation increases labor productivity by 10 - 20 percent. Documentation is being developed for advance components with NAS for the 1K-101u, 2K-52mu and KSh-1kgu combines, their production is planned for 1984-1985. The plant is producing Strela-77 drills for driving rises at angles of 40°-90°, of 1000 mm diameter and up to 100 m long through rock with a strength of up to 10 (on Protod'yakonov's Scale). These tunnels are used to move coal, people, materials, for ventilation and in the deepening of vertical shafts.

The Strela-77's design permits the use of a nonrotating shutter to transfer power for advancement sufficient for drilling full cross section tunnels without preliminary drilling and subsequent widening. The tool-rotator is freely mounted on the advance mechanism carriage. All this makes it possible to enter the machine into a minimal cross section area (7.1 m²), the haulage cars are passed under the advance mechanism. Remote control ensures safety in tunneling seams where there is danger of explosions. Advance mechanisms in drifts are reliably taken apart with the help of hydraulic supports. The control station for automatic drilling is equipped with an electrical machine. A special device is planned for directional tunnelling in preliminarily drilled shafts.

The Strela-77 has better operational indicators than similar foreign models: the working length is 100 m (instead of 46 m), its inclination angle is 40° - 90° (instead of 45° - 90°) and it has higher working speeds.

In 2 years of the 11th Five-Year Plan the plant has increased production volume by 116 percent; the entire growth being obtained through increased labor productivity (by 117.5 percent). The main direction in the development and introduction of effective technological processes involves the reconstruction and technical modernization of the plant on the basis of specializing shops in the production of specific parts, the use of highly productive equipment and metal cutting tools, the creation and introduction of standard unit type machine tools, the mechanization of manual labor, the reduction of labor intensity in billet production and improvements in working conditions and part quality.

During the 10th Five-Year Plan two specialized shops (casing parts and unitized items) have been built and put into operation at the plant. Comprehensively mechanized production sections have been organized, creating the prerequisites for growth in labor productivity and improvements in product quality through the use of highly productive equipment, including standard unit hydraulically operated copying tools, NC machine tools, semi-automatic multispindle machine tools and others.

At the transmission gear shop, the working of parts is concentrated in specialized sections using center -milling, hydraulic copying and multi-spindle automatic tools. NC machine tools have been installed on the lines and are successfully operating in this shop.

The casing item shop primarily uses general purpose equipment. Further growth in labor productivity is being attained through the introduction of standard unit machines. Multispindle machine tools have been manufactured

and introduced for finishing operations on housings for 1GSh-68 combines, ZLP R-79 winches and other items. By the end of 1983 mechanized assembly of finished parts at 11 boring mills will be introduced. Specialized machine tools, which increase labor productivity by 1.5 fold, have been developed by the plant for use at the electric motor housing section to perform labor intensive drilling operations. A metal structure shop has been introduced and put into operation in the welding section, creating the conditions for the mechanization of welding operations. Ten posts for semi-automatic welding in a carbon dioxide atmosphere have been introduced and are operating.

The reduction of manual labor remains one of the most important tasks. We consider the most important directions to be the introduction of progressive technical solutions for loading, unloading, transport and warehouse work, and the mechanization of processes in main and auxiliary operations.

Eight mechanized warehouses using stacker cranes have recently been introduced at the plant. More than 10,000 standardized containers have been introduced at worksites in the plant's shops, creating the basis for the mechanization of transport-transfer operations and considerably improving production standards. During the 11th Five-Year Plan it is intended to organize 10 general plant mechanized warehouses and 6 shop warehouses, annually introduce up to 1,000 units of standardized containers and through this put practically all transport-transfer operations on a container transport basis.

In order to meet the demands of scientific-technical progress and to ensure the delivery of modern, competitive machines, the plant collective is working on the creation of a new generation of mucking machines, the technical standards of which will considerably exceed that of series produced equipment. This above all applies to a series of standardized RKU combines which have advantages over their predecessors:

Power has been increased 2 - 2.5 fold, and depending upon the type and size, ranges from 200 to 630 kWt;

Built-in hydraulic or thyristor non-chain advance mechanisms provide for rates of movement of up to 10 m/min and tractive effort of up to 50 ton-force; built in brakes permit operation without safety winches in seams dipping up to 35°;

Augers at the end of the combine can cut into the seam, eliminating the necessity of preparing niches at ends of longwalls;

Service life prior to the first capital repair has been increased 1.5 fold;

There is a high level of standardization.

The RKU combines will increase miners' labor productivity by 60-70 percent.

In order to master the RKU's series production it is essential to introduce new manufacturing processes, debug the production of new parts and components (grind the tooth surfaces of splines on bushings to considerably improve the longevity of joints in reducer groups; produce longer combine frames, manufacture gears with increased loading capacity and produce operating organs with improved reliability and longevity).

The collective at the Plant imeni Kirov in Gorlovka is responding with deeds to the decisions of the June (1983) CPSU Central Committee Plenum, and is completely resolute about implementing the task entrusted to it -- that of supplying the coal industry with highly productive equipment.

COPYRIGHT: Izdatel'stvo "Tekhnika" "Ugol' Ukrainy", 1983

11574

CSO: 1822/43

COAL

SYNOPSIS OF ARTICLES IN UGOL' UKRAINY , AUGUST 1983

Kiev UGOL' UKRAINY in Russian No 8, Aug 83 p 48

SOVIET MINERS' DAY

/Synopsis of article by A.A. Manzhula, pp 1-4/

/Text/ This article lists the accomplishments of miners in the Ukraine, as well as their work results, and the problems that they face.

UDC 622.26:622.232

INTERNATIONAL EXHIBITION OF MINING EQUIPMENT AT "COAL-83"

/Synopsis of article by P.N. Ivanov, pp 6-8/

/Text/ This article examines the vehicles and equipment of the coal industry, which are to be used in varying geological and technical mining conditions. This equipment was shown by the Soviet Union at the international "Coal-83" exhibition. There are six illustrations.

UDC 658.52.011.56

THE DRUZHKOVA MACHINE BUILDING PLANT OF THE USSR MINISTRY OF THE COAL INDUSTRY

/Synopsis of an article by V.I. Kravtsov, pp 9-11/

/Text/ This article reviews the accomplishments of the Druzhkovka Machine Building Plant and the plans for the future. Eight illustrations.

UDC 622.022.5:658.589

THE KHARKOV 'MINER'S WORLD' PLANT FOR THE MINERS OF THE USSR

/Synopsis of an article by V.P. Veklenko, pp 11-13/

/Text/ This article examines the equipment manufactured by the Kharkov "Svet shakhtera" Plant and the plans for the future. There are four illustrations.

UDC 621.31.002:622.33.012.2

ELECTRICAL EQUIPMENT FOR THE COAL INDUSTRY IN THE ELEVENTH FIVE-YEAR PLAN

/Synopsis of an article by A.I. Parkhomenko, pp 14-16/

/Text/ This article examines the basic developments of the Scientific Production Association "Blast-proof Equipment", which were implemented at the end of the 10th and the start of the 11th five-year plans. It also takes a look at the new electrical equipment that is available to the coal industry. There are six illustrations.

UDC 622.002.6:658.5.018.2

SCIENTIFIC-TECHNICAL INFORMATION - A RELIABLE SOURCE FOR RAISING PRODUCTION EFFECTIVENESS

/Synopsis of an article by Yu.G. Pashchevskiy, pp 17-20/

/Text/ The sectoral system of scientific-technical information and propaganda of the coal industry in the Ukraine is examined in this article. Particular attention is given to the forms of information service for the enterprises and organizations and to the dissemination of progressive experience. There are four illustrations.

UDC 622.83:550.8.001.5

TOTAL EXTRACTION OF COAL FROM THE EARTH

/Synopsis of an article by V.M. Kuleshov, pp 21-23/

/Text/ This article examines the excavation of coal from beneath objects, rock formations and near tectonic discontinuities.

UDC 622.831.22:622.281

INFLUENCE OF THE STRENGTHENING OF A SUPPORT UPON THE DEFORMATION OF THE ROOFING IN DEVELOPMENT WORKINGS

/Synopsis of an article by I.V. Krylov and V.G. Ilyushenko, pp 23-23/

/Text/ This article examines the impact of raising the resistance of a support upon the values of the basic parameters of deforming the rock in the roofing (displacement, rate of displacement, indexes of expansion, and the radius of the fracture zone).

UDC 622.268.13

PERFORMING DEVELOPMENT WORKINGS

/Synopsis of an article by V.G. Kilimnik and I.I. Yaroshinskiy,
pp 24-25

/Text This article analyzes the labor intensiveness of development workings using the combine and drill and blast method. It also takes a look at the structure of operations in the drilling cycle. There is one table.

UDC 622.013:658.5(477.83)

PROSPECTS FOR DEVELOPMENT OF THE LVOV-VOLYNKA BASIN

/Synopsis of an article by N.N. Sydiy, pp 25-27

/Text This article examines the prospects for the geological structure of the Lvov-Volynka Basin and provides a forecast for the development of mines and the availability of equipment. There are two illustrations.

UDC 622.232:658.387.4

Dobropolskaya Mine

IN FAVOR OF A HIGH LOAD IN LOW-CAPACITY SEAMS

/Synopsis of an article by V.F. Chumikov, pp 27-29

/Text This article examines the technical-economic indicators of a longwall that has been equipped with the KM-88 complex and the accomplishments. It also reviews the organization of work in the brigade headed by A.A. Klyavin. There are four illustrations.

UDC 622.232:658.387.4

Novogrodovskoye Mine

EXPERIENCE OF THE HIGHLY PRODUCTIVE WORK OF V.F. KALKOV'S BRIGADE

/Synopsis of an article by T.V. Bukanova, pp 29-30

/Text This article reviews the organization of labor in a comprehensive brigade and its technical-economic indicator and accomplishments. There are two illustrations.

UDC 622.233:658.387.62

EXPERIENCE OF THE WORK OF DRILLING BRIGADE LED BY V.G. NAUMENKO

/Synopsis of an article by T.N. Filimonenko and S.F. Zgonyayko, pp 31-32/

/Text/ This article examines the organization of labor in V.G. Naumenko's brigade, which is subordinate to the Western Anthracite Coal GRE. The factors, which produce high technical-economic indicators of drilling work, and the socialist pledges for the brigade in 1983 are also examined. There is one table and two illustrations.

UDC 622.013:658.32

COLLECTIVE FORMS FOR ORGANIZING AND PAYING MINERS FOR THEIR WORK

/Synopsis of an article by V.D. Zhidchenko, A.Ya. Milishenko and N.A. Novikova, pp 33-34/

/Text/ This article takes a look at the progressive forms for organizing labor and for paying miners. It reviews the basic trends for the further expansion of the brigade organization of labor.

UDC 622.013:658.32

Artemugol Association

MINES OF THE ARTEM COAL PRODUCTION ASSOCIATION IN NEW CONDITIONS FOR PAYING THE MINERS

/Synopsis of an article by A.F. Shak and N.I. Dotsenko, pp 34-35/

/Text/ This article reviews the work results of the Artemugol Production Association, its individual mines and sections after they were switched to new pay systems. It takes a look at the basic trends in achieving high indicators in the mines and sections. There are two tables.

UDC 622.33-002

MECHANIZATION OF PRODUCTION PROCESSES DURING MINE CONSTRUCTION

/Synopsis of an article by A.V. Bykov, pp 36-38/

/Text/ This article examines the questions which lead to an increase in the mechanization of carrying out production processes, labor productivity and production quality, reducing the amount of time required for modernization of existing facilities and for the construction of new ones. There are two illustrations.

UDC 622.012.2.001.2:69.05

NEW HIGHLY MECHANIZED MINE ADDED TO EXISTING MINES IN THE WESTERN DONBASS

/Synopsis of an article by V.S. Mochkov, V.F. Butchenko, A.I. Varkin and Yu.V. Sidorenko, pp 38-41

/Text This article examines the experience of constructing a highly mechanized mine, the "Western Donbasskaya, No 21/22 in difficult geological mining conditions. There are five illustrations and two bibliographic entries.

UDC 622.817.47

DEGASIFICATION OF CONTIGUOUS FORMATIONS IN WESTERN DONBASS

/Synopsis of an article by Ye.M. Ponomarev, N.T. Grishko, and N.F. Kremenchutskiy, pp 41-43

/Text This article examines the experience of degasification of contiguous formations in mines in the Western Donbass. It also takes a look at methods for estimating and optimizing the degasification parameters in view of the complicated geological mining and technical conditions of the region. There is one table.

UDC 622.807:622.81:622.82

ELECTROSTATIC DANGER OF EXPLOSION OF DUST AND WATER AEROSOLS IN COAL MINES

/Synopsis of an article by V.I. Saranchuk and V.N. Kachan, pp 43

/Text This article analyzes the electrostatic danger of dust and water aerosols in the workings of coal mines in connection with various technological processes in relation to the explosion of methane. Coal aerosol is a possible source of combustion. The article describes a methodology for calculating the danger. There is one table.

UDC 622.867.3:614.891.1

GPK HELMET FOR DUST AND GAS PROTECTION

/Synopsis of an article by E.G. Ilinskiy, Yu.A. Kogan, and V.P. Mazanenko, p 44/

/Text/ This article takes a look at the intended purpose, area of use, principle of operation, technical characteristic and also the test results of this new means of individual protection from gas and dust for the miners. There are two illustrations.

UDC 622.766:622.335

ADOPTION OF TECHNOLOGY FOR THE HEAVY MEDIUM ENRICHMENT OF ANTHRACITE AT THE KRASNOPARTIZANSKAYA MINING AND ENRICHMENT MILL

/Synopsis of an article by N.I. Abakumov and V.A. Shcheglov, pp 45-46/

/Text/ This article provides a schematic and technological parameters of a heavy-medium installation at the Krasnopartizanskaya GOF /mining and enrichment mill/. It also takes a look at the results of adopting the technology for the heavy-medium enrichment of anthracite at the mill. One table and one illustration.

COPYRIGHT: Izdatel'stvo "Tekhnika" "Ugol' Ukrainy" 1983

8927

CSO: 1822/357

COAL

SELECTED SYNOPSES OF ARTICLES IN UGOL' UKRAINY, SEPTEMBER 1983

Kiev UGOL' UKRAINY in Russian No 9, Sep 83 pp 47-48

UDC 632.232.83

MACHINE BUILDERS AT PLANT IMENI KIROV IN GORLOVKA ARE WORKING FOR MINERS IN
11th FIVE-YEAR PLAN

[Synopsis of article by A. A. Chichkan, pp 1-4]

[Text] Equipment produced by the Plant imeni Kirov in Gorlovka. Plans for the future, and problems. 6 illustrations.

UDC 622.268.016.34 -- 118.622.838.53

INFLUENCE OF DRIFT VENTILATION PROTECTION EQUIPMENT ON STABILITY

[Synopsis of article by S. K. Strizhiboroda, B. I. Kuritsyn, and O. S. Anosov, pp 4-5]

[Text] Observations on the dislocation of wall rock in ventilation drifts and its stability with various means of protection at mines of the Central Region of the Donbass, recommendations. 2 illustrations

UDC 622.831.031.55

RAPID EXCAVATION OF A PROTECTIVE SEAM IN ORDER TO PREVENT SANDSTONE ROCK BURSTS

[Synopsis of article by V. S. Kulinich, I. A. Novichikhin, and V. Ye. Budkov, pp 5-7]

[Text] Basic principles of regional and local protective excavation of seams to prevent sudden sandstone bursts. Experience in driving preparatory tunnels using top slicing at the Mines imeni Pochenkov and imeni Skochinskiy, research results. 2 illustrations, 1 reference.

UDC 622.232.002.2

INCREASED LOADING AT THIN SEAM WORKING FACES

[Synopsis of article by V. F. Koz'menko, V. M. Viskin, A. I. Statsenko, pp 8-10]

[Text] Improvements in technology for extracting thin seams, being developed with rock cross sectioning. Recommendations and advantages of suggested technology. 2 illustrations.

METHODOLOGICAL RECOMMENDATIONS FOR OBTAINING STANDARD SAMPLES

[Synopsis of article by Yu. A. Onishchenko, pp 10-12]

[Text] Recommended that standard samples be characteristic volumes. the size of which is determined by the research goal and geological-physical factors. The use of standard samples to obtain reliable physical parameters. 1 table, 3 illustrations 3 references.

UDC 622. 232.8:551.2/.3.001.18

DETERMINATION OF RATIONAL PARAMETERS FOR THE ADVANCE TORPEDOING OF ROOFS

[Synopsis of article by N. A. Pravdyukov, V. I. Belousov and I. G. Gapenko, p 13]

[Text] Geophysical research methods in mapping fracture zones in the Molodogvardeyskaya Mine in the Krasnodonugol' Association. Working of seams with roofs which are difficult to collapse (heavy roofs). 1 illustration.

UDC 622.271:622.013

SUCCESSSES OF THE COLLECTIVE AT THE BALAKHOVSKIY STRIP MINE DURING THE 11th FIVE-YEAR PLAN

[Synopsis of article by N. P. Mishchenko, pp 14-15]

[Text] Work results at the Balakhovskiy Strip Mine in the Aleksandriyaugol' Association in 1982. Factors assisting in the collective's successful work. Progressive brigades, socialist obligations for 1983, techno-economic indicators. 1 table.

UDC 622.333:622.271

OPTIMIZATION OF MINING OPERATIONS AT STRIP MINES WITH VARIABLE COAL QUALITY

[Synopsis of article by V. G. Bliznyukov and Kh. D. Chan, pp 15-16]

[Text] Evaluation of work variants at strip mines extracting coal of varying quality, using a comprehensive indicator. 3 illustrations

UDC 622.243.3.001.5

INCREASING THE LONGEVITY OF TEETH IN BUCKETS OF ROTARY EXCAVATORS

[Synopsis of article by Ye. I. Asychenko, pp 16-18]

[Text] Different patterns of rotary excavator bucket teeth loading during the breakup of strong rock in complex high walls. 1 table, 3 illustrations.

UDC 622.3:622.33.00.7

FORMS AND METHODS OF STAFFING IN THE COAL INDUSTRY

[Synopsis of article by A. D. Bondarenko, T. A. Rudyuk , pp 18-19]

[Text] Efficiency of sources, forms and methods of staffing in the coal industry. Recommendations for retaining key personnel. 2 tables.

UDC 622.01:62-503.55.005 "Torezantratsit"

RATIONAL MANAGEMENT OF MATERIAL RESOURCES

[Synopsis of article by I. I. Akin'shin, p 20]

[Text] Organization of the management of material resources at the Torezantratsit Association.

UDC 622.232.8.004

DIRECTIONS FOR INCREASING THE OPERATIONAL INTENSITY OF MECHANIZED COMPLEXES

[Synopsis of article by A. Ye. Tarasenko and N. A. Ivanov, pp 21-22]

[Text] The analysis of mechanized complex use and reasons reducing their technological indicators; structure of breakdowns, basic directions for improving mechanized complex operational intensity.

UDC 622.013:658.387

MODEL FOR DETERMINING THE NUMBER OF WORKERS AT MINE EXTRACTION SECTIONS

[Synopsis of article by A. V. Yeliseyev, p 22]

[Text] Model for determining number of workers at extraction sections.

UDC 622.232.83

TECHNICAL CHARACTERISTICS OF DRILLING TYPE TUNNELING COMBINES FOR STRONG ROCK

[Synopsis of article by A. G. Laptev, V. A. Deynichenko, A. M. Levin, pp 23-24]

[Text] Brief technical characteristics of Soyuz-19, Soyuz-19u and KRT drilling type tunnel driving combines equipped with disk cutters. 1 table, 2 illustrations 1 references.

UDC 622.284.54.004.6

IMPROVING THE RELIABILITY OF HYDRAULIC POSTS FOR MECHANIZED ROOF SUPPORT

[Synopsis of article by A. N. Solomakhin, pp 24-25]

[Text] Results from the study of defects and experimental research on seal failure of posts due to damage and abrasive wear of piston rings. Recommendations. 2 illustrations.

UDC 622.489:621.396.61/.62 - 213.34.001.4

INDUSTRIAL TESTING OF VChSL-2 HIGH FREQUENCY COMMUNICATIONS APPARATUS

[Synopsis of article by A. I. Popov, pp 25-26]

[Text] Functions, equipment and operating principles of the VChSL-2 apparatus. Design of portable and drift apparatus. Test results in combine longwalls in steeply dipping seams. 2 illustrations

IKU-2 SPARKPROOF ELECTROCONTACT DEVICE

[Synopsis of article by M. Ye. Sytnikov, A. V. Panin, and V. M. Korolev, p 27]

[Text] Functions, technical characteristics, design and operating principles of the IKU-2 sparkproof electrocontact device, developed by the VF GUA and the DZShA, features of the device. 3 illustrations.

UDC 622.625.28 - 83

PROSPECTS FOR THE DEVELOPMENT OF NONCONTACT ELECTRIC LOCOMOTIVE TRANSPORT

[Synopsis of article by G. Ya. Palant, S. Yu. Kravchinskiy, Ye. Kreymer, pp 28-29]

[Text] Results from industrial testing of an experimental group of equipment for ore haulage using high frequency V-14 electric locomotive. Advantages and necessity of beginning series production. 3 illustrations.

UDC 621.316.71:622.67

APPARATUS FOR THE SPEED CONTROL OF LIFT MACHINERY WITH ASYNCHRONOUS DRIVE

[Synopsis of article by I. Ya. Gal'perin, A. V. Gavrilov and Yu. M. Tul'chinskiy, pp 29-31]

[Text] Basic control device for automated lift machinery forms the signal for the set speed with limits on acceleration and stops, develops error signals for speed, selects lift motor operating conditions and controls mechanical braking. 3 illustrations.

UDC 622.6.611.63

IMPROVEMENT OF SCRAPER CONVEYOR OPERATION

[Synopsis of article by Yu. V. Kuznetsov, pp 31-32]

[Text] Proposals for changing traction units of face conveyors to reduce breakdown rate. 4 illustrations

UDC 622.673.1 - 9.001.24

ON THE METHODOLOGY OF CALCULATIONS AND RATIONAL PARAMETERS FOR MINE LIFT INSTALLATIONS

[Synopsis of article by V. I. Dvornikov, pp 33-35]

[Text] Methodology for calculating and selecting basic lift equipment. Optimization of parameters through the minimization of adjusted [privedennyye] costs. Formulas for use in design practice. 1 table.

UDC 621.316.925

PROTECTION OF CAPACITOR DEVICES FROM SHORT CIRCUITS AND HIGHER HARMONICS

[Synopsis of article by I. I. Kovalenko, N. P. Ol'khovik and R. K. Samniashvili, pp 35-36]

[Text] Operation of a device for the protection of capacitors from short circuits and higher harmonics. 3 illustrations.

UDC 622.625.24:621.869.7

UNIT TRAINS AT THE MINE IMENI FRUNZE

[Synopsis of article by A. I. Lesnikov, p 36]

[Text] Proposals for the improvement of the design of PS-3.5 unit trains.

UDC 622.

DESORPTION MEASUREMENT AS A METHOD FOR PREDICTING SUDDEN ROCK BURSTS

[Synopsis of article by S. G. Irisov, pp 37-38]

[Text] Methodology for calculating critical values of gas desorption speed through using coal probes. Results of experimental measurements of gas emission speed which confirm the principles upon which the desorption metric method of predicting explosions is based. 1 table, 3 illustrations 2 references.

UDC 622.412+622.817.4

INFLUENCE OF CHANGES IN BAROMETRIC PREASURE UPON GAS EMISSION IN BLIND TUNNELS

[Synopsis of article by V. S. Sergeev, I. N. Zinchenko and A. Ye. Gorbatenko, p 39]

[Text] Theoretical and experimental research on the influence of mine pressure upon gas emissions in blind tunnels. Dependence of gas emission on pressure changes. 1 illustration.

UDC 622.414.3:622.82

DETERMINING PRESSURE LOSS IN TUNNELS DURING FIRES

[Synopsis of article by V. A. Dolinskiy, S. A. Alekseyenko, p 40]

[Text] The relationship for calculating pressure loss in tunnels during fires obtained on the basis of the Zhirar -Dobysusson Formula is compared with experimental results. The formula is recommended for calculating pressure loss in tunnels located at the foci of the fire along the ventilation flow. 1 table, 1 reference.

MINE WATER FOR COMPRESSOR COOLING

[Synopsis of article by L. M. Vitrenko, E. Ya. Afanas'yeva and V. N. Santylova, pp 41-42]

[Text] The possibility of creating a two loop system for cooling compressors, permitting the replacement of feed water by mine water. 1 table, 3 illustrations.

UDC 622.33.002:551.491.7

METHODOLOGY FOR CALCULATING NON-STEADY STATE FILTRATION OF WATER BACKFILLED HORIZON

[Synopsis of article by E. Ya. Kipko, Yu. A. Polosov and N. L. Bykov, pp 42-43]

[Text] Results of analytic studies of non-steady state filtration in a cylindrical backfilled curtain, with consideration given to the initial pressure gradient. Practical significance of methodology for calculating non-steady state filtration of water in backfilled horizon.

UDC 622.232:550.822:519.2

EVALUATING THE RELIABILITY OF FORECASTS FOR SEAM DEVELOPMENT

[Synopsis of article by R. A. Frumkin and V. N. Okalelov, pp 43-44]

[Text] Results of estimating the reliability of forecasts for engineering-geological indicators using exploratory drilling samples. Patterns in the formation of systematic and random errors in forecasting. 1 table.

UDC 621.646:622.7:622.33

TESTING WEAR RESISTANT STEEL PIPE AT COAL ENRICHMENT FACILITIES

[Synopsis of article by V. P. Malokostov, B. F. Bragin and V. V. Shachnev, p 44]

[Text] Results of testing two layer spiral weld pipe (TDC) for transporting bituminous and anthracite slurries to coal enrichment facilities. 1 table.

COPYRIGHT: Izdatel'stvo "Tekhnika" "Ugol' Ukrainy", 1983

11574

CSO: 1822/43

ALTERNATE FUELS

INCREASING USE OF GEOTHERMAL ENERGY

Introductory Statements

Moscow GAZOVAYA PROMYSHLENNOST' in Russian No 10, Oct 83 pp 1-5

[A collection of articles with the general title: "Use Geothermal Energy Widely!" under the heading: "Realizing the Decisions of the 26th CPSU Congress". Material enclosed in slant lines printed in boldface.]

[Text] As one of the basic directions of the social and economic development of the USSR in the years 1981-1985 and the period up to 1990, it is specified to increase the scale of the use in the national economy of renewable sources of energy including geothermal energy.

/ In connection with the increasing costs of extracting and transporting organic fuel into industrially developed regions, the urgency of the problem of utilizing the heat deep in the Earth has increased.

In giving important national economic significance to the solution of this problem, the 26th CPSU Congress defined geothermal heat as one of the fundamental forms of renewable natural energy.

At present, within the Ministry of the Gas Industry a multi-branched network of production administrations for the utilization of hot springs water are functioning; namely, the Caucasus, the Northern Caucasus, the Kubansk, the Georgian, and the Kamchatka administrations are combined with the VNIPIgeoterm [All-Union Scientific Research and Planning Institute for Geothermal Energy] in the structure of the NPO [Scientific and Production Association] "Soyuzburgeothermiya" [All-Union Association for Drilling Geothermal Wells].

During the 10th Five-Year Plan, the volume of hot springs water recovered amounted to 175 million m³. In the current Five-Year Plan it is planned to reach 258 million m³.

The largest existing resources of renewable deep heat are in the Northern Caucasus economic region where geological survey workers have discovered them in amounts up to 2 million m³ per day.

In recent years the structure of the usage of hot springs water has been changing toward agriculture. So, in 1982, 36 percent of the water extracted was delivered for heating hothouse and hotbed concerns, and 43 percent for community and domestic needs of towns and settlements of which 15 percent satisfied technological needs of industrial enterprises.

Many years of experience show that the use of geothermal energy is economically advantageous. For example, the cost of 418 Joules of heat obtained from geothermal wells is 1.5-2 rubles in the region of the Caucasus and Ciscaucasia. This is several times less than the cost of heat obtained by the traditional method in these regions. The economic gain is growing because of the saving of water in the use of the product of geothermal sources for production purposes and in the form of hot water supplies. The use of hot springs water is highly effective for the cultivation of vegetables, the cost of one centner of which amounts, in all, to 20-30 rubles. The realization of the program for the widespread use of hot springs water for the needs of the agricultural industry includes the construction of hothouse and hotbed concerns, the total area of which will reach 175 hectares by the end of the Five-Year Plan.

Geologists estimate that the use in the national economy of the deep heat in the Earth by daily extracting hot springs water and steam-and-water mixtures in amounts, respectively, of 22 million m³ and 0.43 million tons, permits releasing 50 million tons of standard fuel. In the extraction and utilization of these resources it is necessary to solve a number of important scientific and technical problems; namely, problems about the complete utilization of hot springs water with the maximum heat recovery and, in a number of cases, with the extraction of valuable chemical components, and problems in the creation of efficient technological systems for water treatment and for its disposal.

The articles in this section tell how the industry is solving these problems./ [Paragraphs enclosed in slant lines were printed in bold face.]

COPYRIGHT: Izdatel'stvo "Nedra" "Gazovaya promyshlennost'", 1983

Urgent Geothermal Development Problems

Moscow GAZOVAYA PROMYSHLENNOST' in Russian No 10, Oct 83 pp 2-5

[Article by R. S. Vorob'yeva, deputy chairman of the Scientific and Technical Council: "Urgent Problems of the Development of Geothermal Sites".]

[Text] A combined conference of the sections of the Scientific and Technical Council of the Ministry and the section on Geothermal Energy of the Scientific Council on Renewable Sources of Energy of the GKNT [State Committee of the USSR Council of Ministers on Science and Technology] which was conducted by the deputy minister of the gas industry, M. I. Agapchev, was devoted to an important problem; namely, the introduction of a fundamentally new method for closed-loop development at hot springs sites by means of reinjecting the spent heat carrier back into the water-bearing strata being exploited.

The participants at the conference noted that, in the sphere of national economic use of such sites, there are primarily fresh, or weakly-mineralized hot springs whose development is carried out during the free-flowing operation of the wells. This method, based on the natural energy in the formation, as a rule provides relatively small amounts of water. A substantial shortcoming of the free-flowing method of development is the limitedness of the areas in which it can be used advantageously. For technical reasons it is extremely difficult to increase the scale of hot springs water recovery by the use of high-capacity pumps.

Over the years 1981-1983, experimental work was done by organizations of the Ministry of the Gas Industry on the reinjection of spent hot springs water at the Makhachkala-Ternairsk, Voznesensk, Mostovsk, and Khankalsk sites in the Northern Caucasus and at the Pauzhetsk site on Kamchatka.

For accelerating work on introducing the closed-loop method of developing geothermal sites, for recovering additional resources of hot springs water by reinjection, and also for the complete utilization of it and for the effective solution of questions about protecting the environment from heat and chemical pollution, the conference participants recommended, as the most promising directions for research in the field of using the heat deep in the Earth, the following:

Investigation of the filtration and heat transfer processes of deep water-bearing strata with regard to their intrinsic nonuniformities according to a set of filtration, capacitive, and thermal properties, and the perfection on the basis of these investigations, of techniques for predicting the cooling processes of water-bearing strata and the passage through them of injected water.

Development of efficient methods for surveying hot springs sites and evaluating the productive resources of the heat carrier as applied to exploitation with maintenance of formation pressure.

Investigation of the physical and chemical processes in the systems - in the spent hot springs water, in the water in the formation, and in the rock surrounding the water - and evaluation of their effect on the collection properties of the rock of a productive stratum.

Development, for promising regions, of efficient and comprehensive methods for revealing productive strata, for putting injection wells into operation, and for maintaining and improving their intake rate in the injection process.

Development of the technology and technical means for the complete use of hot springs water and for the fullest possible recovery of its heat potential.

The well-founded scientific development of the costs of geothermal resources.

Detailed geological and hydrological study of geothermal systems and the regions for priority exploitation.

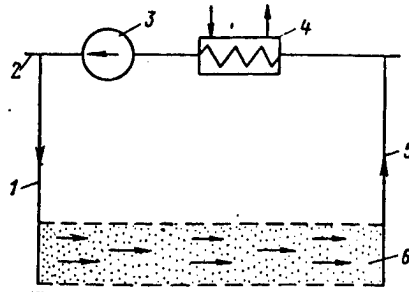

Figure 1. Schematic diagram of circulation system

- 1- underground boiler (heating zone); 2- injection well;
 3- high pressure pumping installation; 4- heat exchanger;
 5- producing well; 6- permeable zone.

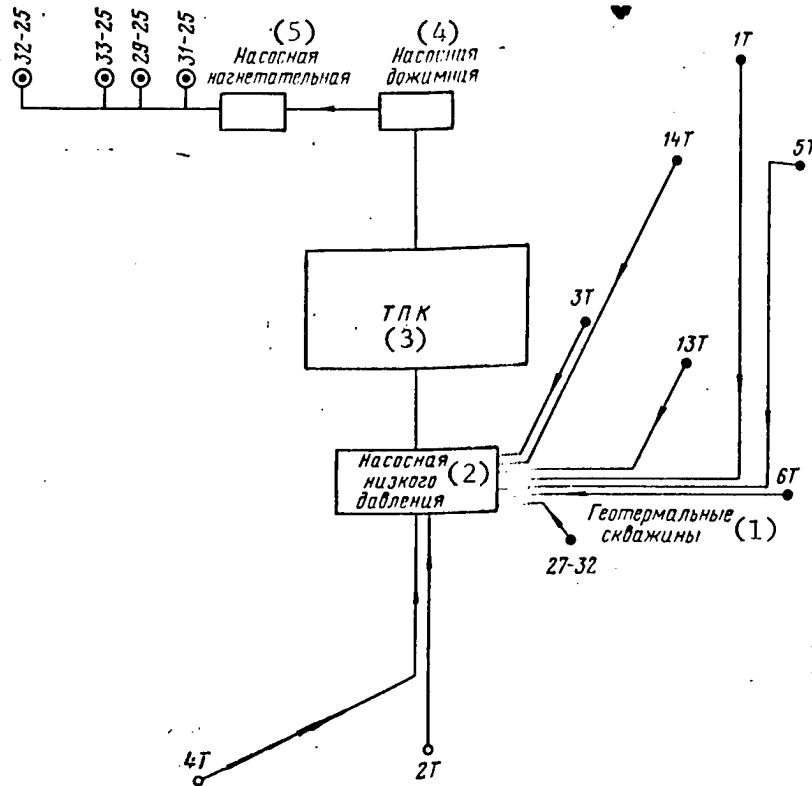

Figure 2. Diagram of geothermal water intake with maintenance of formation pressure.

- (1) geothermal wells, (2) low pressure pump, (3) TPK [heat exchanger]
 (4) booster pump (5) injection pump.

The following tasks have been assigned to the "Soyuzburgeotermiya" scientific and production association as the leading organization:

Perfecting geological and geophysical methods of searching for and surveying geothermal sites.

The development of techniques for designing the structures of geothermal wells with regard to their installation and use.

The development of criteria for the quality of water for injection, of methods of water treatment, and of methods of conducting experimental industrial injections.

Increasing the experimental industrial operations at the Khankalsk site.

COPYRIGHT: Izdatel'stvo "Nedra" "Gazovaya promyshlennost'", 1983

Underground Circulation Systems

Moscow GAZOVAYA PROMYSHLENNOST' in Russian No 10, Oct 83 pp 2-3

[One of a collection of articles on utilizing geothermal energy, this one entitled: "A Promising Direction for Developing Geothermal Energy".]

[Text] The Ministry of the Gas Industry is giving much attention to the utilization of hot springs in the national economy.

The scientific and production association "Soyuzburgeotermiya" which has been set up in Makhachkala is coordinating the activities of all the drilling, industrial, and scientific research enterprises and subdivisions of the industrial sector that are doing work in exploring for and developing geothermal sites.

In this year the ministry has adopted measures for broadening the front of drilling operations, for the creation of a production and experimental base, and for specialization of construction and installation operations and transport services for the subdivisions of the association.

In the future, underground circulation systems will receive broad development. Their application will permit the use of sites with highly mineralized water containing harmful admixtures, and also will increase the recovery of the heat potential of the rocks. Figure 1 is a schematic diagram of a circulation system.

Since 1981, in accordance with the scientific program of the Ministry of the Gas Industry, experimental work has been done on injecting processed hot springs water into the XIIIth stratum at the Khankalsk site to maintain the formation pressure. In this, positive results were obtained in the 1981-1983 heating seasons. At the Khankalsk geothermal site the country's first underground circulation system (PTsS) is operating in a temporary arrangement. The experimental industrial exploitation of the XIIIth stratum is being accomplished with the injection of spent water into four injection

wells in a volume of 4000-6000 m³/day. As a result, the formation pressure in this stratum was stabilized, the water level was raised, and wells, formerly standing idle, began flowing.

At present the "Soyuzburgeotermiya" NPO is completing a plan for the development of the Khankalsk site with maintenance of formation pressure. The drilling of production and injection wells and the exploitation, additionally, of the IV-VIIth and the XXIInd strata will be called for in the plan. On the basis of the development project, a plan will be drawn up for equipping the Khankalsk site with a system for injecting spent hot springs water. In doing this it is planned to bring the amount of injection up to 10,000 m³ per day; that is, an underground circulation system for the whole site will begin to operate (Figure 2).

For the development and acceleration of work on introducing the closed-loop method for developing geothermal sites, it is planned to conduct investigations of the processes of filtration and heat transfer in deep water-bearing strata. On the basis of them a technique will be developed for evaluating and predicting the cooling process of a water-bearing stratum and movement through it of injected water. Also, on the basis of the investigations, efficient methods will be developed for surveying hot spring sites and evaluating the resources of the heat carrier as applied to its exploitation with maintenance of formation pressure. In addition, the technology and technical means will be developed to assure the complete use of hot springs water and the fullest recovery of its heat potential.

The future development of work on the creation of underground circulation systems will first be done at those sites at which positive results have been obtained in trial injections of water (at the Mostovsk site in Krasnodar kray, the Izberbashsk site in the Dagestan ASSR, the Kindgsk in the Georgian SSR, and the Pauzhetsk on Kamchatka). The construction of underground circulation systems at these sites will be a significant step forward in the use of the heat deep in the Earth.

COPYRIGHT: Izdatel'stvo "Nedra" "Gazovaya promyshlennost'", 1983

Disposal of Geothermal Water

Moscow GAZOVAYA PROMYSHLENNOST' in Russian No 10, Oct 83 pp 4-5

[One of a collection of articles on utilizing geothermal energy, this one entitled: "Processing Geothermal Water".]

[Text] From the beginning of organizing work on the practical use of geothermal water up to the present, the majority of geothermal sites were planned without taking the quality of the water into account. The water was therefore utilized in a direct method - "from well, to consumer, to disposal". In practice, in such a scheme, extremely high-quality water, near in consistency to drinking water, is used.

The question arises: how is water to be used that is corrosive, is precipitating salt, or which contains an impermissible amount of such ingredients as phenol, arsenic, boron, etc?

The answer to the first part of the question should be simple - low quality water causing corrosion or salt precipitation must be used in a closed loop where the hot springs water gives up its heat through a special heat exchanger. In the Dagestan ASSR such a method of using hot springs water is applied in the city of Kizlyar for heating living quarters, and at the Makhachkala-Ternairnsk geothermal site for the Ternairnsk hothouse complex. For hot springs water containing harmful substances, special processing is necessary which can be carried out by various methods - physical, chemical, or electrical or a combination of them.

The problem is complicated by the fact that disposing of hot springs water which has been spent in geothermal systems into surface reservoirs (rivers, lakes, seas, etc.) is prohibited by the regulations for preserving the environment and the operative laws. Most difficult is disposal of hot springs water which contains more than 0.001 mg/liter of phenol. Existing methods for cleaning phenols from water, for economic reasons, have turned out to be unacceptable for hot springs water. For a solution of this problem, the VNIPIgaz [All-Union Scientific Research and Planning Institute for Gas] was enlisted and a method was worked out for dephenolization of hot springs water by chemical action on the phenols - by oxidizing them with sodium hypochlorite (NaOCl). This reagent, however, is not produced in concentrated form and for processing large amounts of water containing up to 10mg/l of phenols, several hundred tons are required. In this, account must be taken of the difficulty of storing and transporting it because of its very high aggressiveness. In addition, this reagent can be transported only in special rubberized or enameled vessels.

Because methods for dephenolization should be cheap, industrial workers proposed a series of methods for reducing the concentration of the phenols by oxidizing them with the oxygen in the air by using devices for spraying phenolated water over ponds or settling tanks. This, however, did not give positive results. The dephenolizing effect amounted in all to 8-12 percent with substantial costs.

A special apparatus was constructed by a group of engineers, technicians, and scientific workers of the Ministry of the Gas Industry. It is an aerator for mixing liquids with gases. It is a device in which hot springs water is mixed with air and, because of the effect of atomization, it achieves a high degree of oxidizing and blowing out the phenols. A feature of the aerator is that it is easy to regulate the shape of the trajectory of the movement of the water in it. The stepped shape of the flow channel for the air-water mixture also contributes to an increase in the dephenolization effect. In this, a finely divided medium is created assuring good contact between the air and water and a principal part of the phenols and other organic compounds are destroyed. The use of the aerators reduces the amount of phenols in hot springs waters by 30-50 percent. An aerator is the first stage of an installation for dephenolizing water and it permits a substantial reduction in the amount of sodium hypochlorite needed.

The structure of the aerator consists of extremely simple parts having high reliability and ease of regulation. Any sort of breakdown is practically excluded.

In the years 1979-1980 at the Makhachkala-Ternairsk oil field in Dagestan, experimental industrial tests were conducted twice on the dephenolization of hot springs water with sodium hypochlorite. In the second test the aerator was used in combination with sodium hypochlorite and 100 percent dephenolization was achieved with a $400 \text{ m}^3/\text{hr}$ flow of the water being processed and a reagent flow of 1000 liters/hr. During this test the phenol content before treatment was 3.82 mg/liter and after it - 00.0 mg/liter , and the sodium hypochlorite consumption amounted to about 24 tons per day.

As already mentioned, the preliminary treatment of the water by the aerator reduces the amount of the phenols by 30-50 percent and, correspondingly, the consumption of reagent.

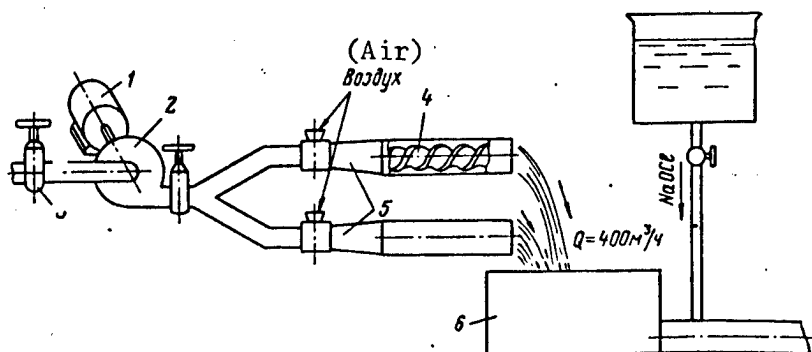

Figure 1. Diagram of installation for the dephenolization of hot springs water using aerators and dosing with the reagent NaOCl .

- 1- motor, 2- pump, 3- valve, 4- worm of aerator, 5- aerators
- 6- tank with 10 m^3 capacity.

Figure 1 shows the basic scheme of a combined installation for dephenolizing water using aerators and dosing with reagent. Figure 2 is a diagram of the installation for dephenolizing discharged hot springs water at the Maykopsk site.

As a result of the industrial experiment using the combined installation at the Maykopsk hot springs site, dephenolization to the allowable phenol concentration was achieved. A preliminary calculation established that the maximum reagent consumption during a heating season (154 days) is 60 to 80 tons

Soon, the first industrial installation for the dephenolization of hot springs water will be installed and put into operation.

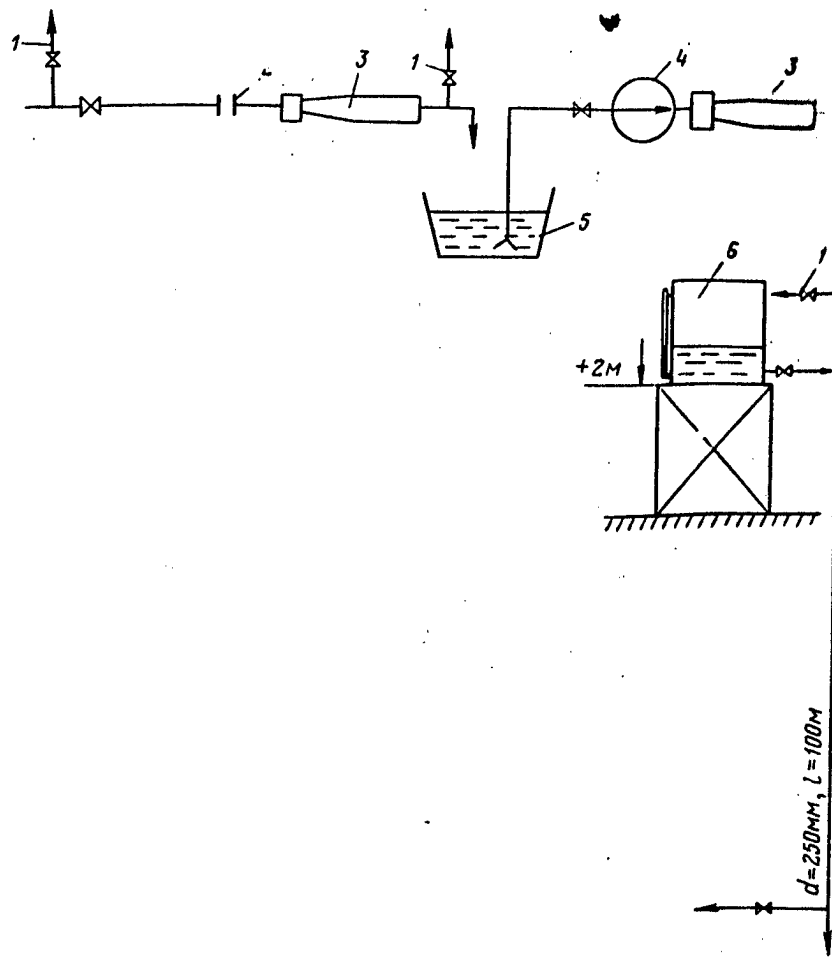

Figure 2. Diagram of the installation for the dephenolization of discharged hot springs water at Maykopsk.

- 1- pipe connection for drawing off samples, 2- flow meter, 3- aerator, 4- pump ($Q = 80-120 \text{ m}^3/\text{hr}$), 5- separator tank, 6- sodium hypochlorite tank with sight glass.

Authors of the printed selection of articles: F. G. Kharakhash'yan, Yu. S. Sedykh, and V. G. Renne (Administration for drilling gas and gas condensate wells).

COPYRIGHT: Izdatel'stvo "Nedra" "Gazovaya promyshlennost'", 1983

9136
CSO: 1822/76

ALTERNATE FUELS

SELECTED SYNPOSES OF ARTICLES IN 'TORFYANAYA PROMYSHLENNOST' ,
AUGUST 1983

Moscow TORFYANAYA PROMYSHLENNOST' in Russian No 8, Aug 83 p. 32

UDC 622.331:656.2

THE USE OF NARROW-GAUGE RAILROAD TRANSPORT BY THE BELORUSSIAN SSR
MINISTRY OF THE FUEL INDUSTRY

/Synopsis of an article by V.I. Dubok and A.V. Kachalov, pp 2-5

/Text This article describes the use of narrow-gauge railroad transport by the peat enterprises and briquette peat plants of the BSSR Ministry of the Fuel Industry. It lists the indicators of its work. The article also examines the new equipment that is used in transporting peat and the leading elements in the transportation shops. There are six illustrations.

UDC 622.331:656.2

THE SHATURA TRANSPORT ADMINISTRATION IN THE ELEVENTH FIVE-YEAR PLAN

/Synopsis of an article by V.A. Guskov, V.V. Kiselev, and V.M. Shchablenkov, pp 5-8

/Text This article reviews the work results of the Shatura Transport Administration during the first two years of the 11th Five-Year Plan and for the first six months of 1983. The winners in the socialist competition are listed. There are five illustrations.

UDC 622.331:625

MECHANIZATION OF TRANSPORTATION WORK

/Synopsis of an article by Ye.M. Kalashnikov, pp 8-10

/Text This article characterizes the work of the Gusevskiy Unified Peat Transport Service for the mechanization of labor-intensive production processes. It defines the role of efficiency experts in the enterprise in solving the problems facing the collective. There are three illustrations.

UDC 622.331.002.2:658.387

COMPETITION INITIATORS - IN THE LEADING RANKS

/Synopsis of an article by P.P. Krygina, pp 10-12

/Text This article tells of the winners in the socialist competition among the collectives of builders from Rostopstroy /RSFSR Trust for the Construction of Enterprises for the Fuel Industry. There are three illustrations.

UDC 622.331:621.001.2

DETERMINING THE SERVICE LIFE OF EQUIPMENT USED IN THE PEAT INDUSTRY AT THE DESIGN STAGE

/Synopsis of an article by A.V. Semenov, pp 13-16

/Text This article poses and solves the question of selecting rational service lives for machinery used in the peat industry at the design stage. Equations for the functional of losses are found and analyzed. There is one table and five entries in the bibliography.

UDC 622.331:622.861.002.5

REGARDING THE PROPULSIVE DEVICE FOR DIGGING AND REPAIRING CONTOUR CHANNELS

/Synopsis of an article by Yu.V. Krasnov and V.K. Kirillov, pp 16-18

/Text This article describes the nature of the interaction of the wheeled and tracked propulsion devices for the machine that digs and repairs contour channels when there is a loss of passability. It defines the boundary properties of peat deposits according to the passability condition. It lists the main reasons for the inadequate passability of a vehicle with a propulsion device on rigid metal rollers. The article discusses the feasibility of manufacturing the MTP-32B vehicle with a tracked propulsion device, which enables the vehicle to perform preparation of peat fields. There are four listings in the bibliography

UDC 622.331.004.4

COMPREHENSIVE EVALUATION OF THE TENDENCY OF SHREDDED PEAT TO SPONTANEOUS COMBUSTION AND SELF HEATING

/Synopsis of an article by L.M. Malkov, V.A. Kozlov and Ye.V. Gubler, pp 18-21/

/Text/ A new method of predicting the tendency of shredded peat to self-heating and spontaneous combustion, which is based upon new concepts regarding the mechanism of these processes, has been developed. This method makes it possible to take into consideration the influence of the natural genetic, meteorological and technological factors. There is one table and six listings in the bibliography.

UDC 553.97:491.4

PURIFICATION OF THE WATER DISCHARGED IN PEAT DEPOSITS THAT ARE BEING DEVELOPED IN SPECIAL SETTLING TANKS

/Synopsis of an article by I.F. Largin and N.V. Lavrov, pp 21-25/

/Text/ This article defines the optimal speed of water flow in settling tanks and the minimum amount of time for the exchange of water to permit the effective settling of the suspended particles. The article also provides recommendations for the design of settling tanks. There are two illustrations, three tables and three entries in the bibliography.

UDC 662.73.004.82:634.08

THE USE OF WOOD WASTES FROM PEAT ENTERPRISES IN THE PRODUCTION OF ARBOLIT

/Synopsis of an article by V.M. Naumovich, A.N. Morozov, S.G. Sveridov and I.B. Eshenbakh, pp25-28/

/Text/ This article examines a technological diagram that has been developed and proposes an equipment arrangement for obtaining a conditioned filler for arbolit using wood wastes from peat enterprises. The article lists research results from the study of the construction properties of arbolit made of a filler of stumps and roots from peat enterprises. The economic effectiveness of using wood wastes from peat enterprises for the production of arbolit is demonstrated. There are four illustrations and seven entries in the bibliography.

COPYRIGHT: Izdatel'stvo "Nedra", "Torfyanaya promyshlennost'", 1983

8927

CSO: 1822/358

NUCLEAR POWER

FIRST ENERGY UNIT PUT INTO OPERATION AT SMOLENSK AES

Moscow TRUD in Russian 1 Oct 83, p 1.

[Report on interview with A. N. Semenov, deputy minister of Power and Electrification of the USSR by correspondent V. Kapel'kin]

[Text] Yesterday, at 8:30 AM, the first one million kilowatt power unit started operating at its design power level at the Smolensk Nuclear Power Plant, which is under the patronage of "Trud". At the request of our correspondent V. Kapel'in, Deputy Minister of Power and Electrification of the USSR A. N. Semenov commented on this event.

The total power of the twenty-nine power units at eleven nuclear electric power plants operating in the country is 17.2 million kilowatts. Therefore, the role of such a large unit as the one at the Smolensk AES [Atomic Electric Power Plant] is very noticeable. This is an important stage in the fulfillment of the resolution of the 26th CPSU Congress on accelerated development of our sector of industry in the European part of the USSR. This power unit will save two million tons of standard fuel a year, each ton of which, according to the prices of the world market, costs, on the average, 200 rubles. This a tremendous gain!

[Question] Together with one of the units of Kursk AES, the "millionaire" starts a unified energy power series with a reactor of the RBMK-1000 type. What was shown during the first months of its operation?

[Answer] The power unit was constructed with a high degree of quality. From the beginning of its operation, in the process of its development of the design power, more than 3.2 billion kilowatt-hours of electric energy were produced, which means that the annual plan is fulfilled successfully. During this time, a step-by-step increase of the power of the unit was carried out by a special program with thorough adjustments and regulation of the plant's systems. The young team managed successfully to improve and put into operation an unloading and loading machine (RZM) which made it possible without human participation and shutdown of the reactor to replace the spent fuel assemblies. The information and computing system "Skala" which performs the functions of control and monitoring is functioning accurately. At the last stage of the preparation for emerging to its full capacity, the stage of planned preventive repairs, the team under the direction of A. V. Aksyutin distinguished itself. The unit was

brought to one million kilowatts by the leading shift of operation workers of N. D. Donskov. Although the workers of the Smolensk AES had many novices in atomic energy industry, the successful progress of the work indicates that the modern technology is in skillful and reliable hand.

[Question] In designing nuclear power plants, international safety standards used in the MAGATE [International Agency on Atomic Energy] are taken into consideration. What are the results of their monitoring at the plant and outside of its limits?

[Answer] I would like to stress that, in the course of the adjustment and its startup, the problems of safety were given very close attention. It can be stated that even in the case of natural calamities, there will be no radioactive discharges into the environment. Specialists know how, for example, a high degree of purification from admixtures of water circulating in the circuits of an AES is important. Our unit includes fourteen effective special water purification systems. In principle, any contamination of the water reservoir at the Desna River is eliminated. Thorough control of soil samples, vegetation ✓ sediments, water, and bottom sediments in a radius of 45 kilometers indicate only a practically natural radioactivity background. It is hundreds of times lower than the maximum permissible values.

In short, the first unit of Smolensk AES is functioning reliably. It is completely ready for the autumn-winter peak of energy loads. We wish it the best!

10,233
CSO: 1822/46

NUCLEAR POWER

PROBLEMS OF DISORGANIZATION, MISMANAGEMENT AT ROSTOV AES

Moscow SOTSIALISTICHESKAYA INDUSTRIYA in Russian 3 Sep 83, p 1

[Article by V. Uzhakin, staff correspondent, Volgodonsk]

[Text] "Atomenergostroy", a general contractor for AES [atomic electric power plants], is considered to be one of the best construction subdivisions of the trust "Volgodonskenergostroy". This is indicated by its operation indexes. However, the situation there is not as good as it may seem when one is dealing with its report data.

Before the party meeting at which the communists of the administration discussed their results of the June (1983) Plenum of the CPSU Central Committee, I visited the reactor department, met with the workers, and inquired about their mood when they were going to the meeting. N. Potapchik is the head of the concrete workers team. More than once, his team was a leading team, showing record results. Its six-months plan was performed at a rate of 167%. It was a good index. But we are not talking about him.

He asked: "On the way to the AES, did you see the slogan 'The reactor department is to produce a plus 13.2 mark in 1983?'"

"Of course, the slogan can be seen from afar".

"Well, for a second year we haven't been able to reach this mark. The painter only changes the years on the billboard, but the work is not moving at all."

It was also recalled that the pledges of the personnel of the trust "Volgodonskenergostroy" contains the following: "To ensure in 1983 the introduction of the planned projects of the Rostov AES, including the reactor department, to a mark of 25.7". But the slogan today is still calling upon the competitors to achieve a mark of 13.2, but without any success. This is not at all due to any objective circumstances. It is their own irresponsibility and lack of discipline. The Volgodonsk Administration of the trust "Gidromontazh" [State All-Union Construction and Installation] headed by G. Bobkov was installing in the course of six months a powerful crane "SKR-3500" which was expected to deliver structural members. But because of gross violations of the operation rules, the crane collapsed and turned into a pile of scrap metal. This was reported with indignation to the editorial office by the builders of the AES. The letters said that the cost of the crane was 370,000 rubles. Because of lack of

control and inability to organize the procedure, it failed. The second crane "BK-1000" also stopped after it was put together because it was not officially accepted for operation. Now, in essence, the reactor department has no crane to operate.

N. Potapchik continued that, in general, they had to split the team into two parts. Half of the people were sent to other projects.

The lack of organization at the construction site and lack of attention to the people were discussed by communists at a party meeting. The favorable indexes at the construction did not show gross violations in the deadlines of the performance of the assignments. At the main projects of unit No 1 which were planned to be put in operation in 1985, only one half of the plan of the current six-months period was fulfilled, and from the beginning of the construction the lag is over a year. The above-norm amount of structural members and materials is eight million rubles. Recently, the trust "Volgodonskenergostroy" developed measures "for ensuring the fulfillment of the construction program of Rostov AES in 1983" and issued an order "For additional measures to intensify the construction of the AES".

We shall not belittle the significance of all these measures implemented by the administration of the trust. However, they do not, obviously, include one measure: increased responsibility of the subordinate personnel, particularly, that of the head of the administration of "Atomenergostroy", A. Trofimenko, for the work section entrusted to him. Being involved in paper work, such as compiling all kinds of measures and orders, the trust actually assumed the position of a detached on-looker and did not make any serious attempt to put a stop to disorganization and mismanagement in the subordinate administration.

10,233
CSO: 1822/46

NON-NUCLEAR POWER

PRODUCTION OF NEW 300,000 KW TURBOGENERATOR INITIATED

Baku VYSHKA in Russian 13 Oct 83 p 2

[Article by S. Davydov, TASS Correspondent: "The Scientific Section of an Enterprise"]

[Text] The first components of a turbogenerator with a capacity of 300,000 kw which will utilize the principle of superconductivity have been put into production at the Leningrad Elektrosila Association.

This unit inaugurates a generation of electrical machines of practically unlimited capacity--liquid helium at a temperature close to absolute zero will circulate in their rotor windings. This reduces to a minimum energy losses due to resistance. At the same time construction has begun on a stand for the testing of innovations. Such is the operating principle of an enterprise where the interests of science and of production are organically joined.

Cryogenerators represent the future of energy generation. They are developed according to a plan that has been tested on hundreds of electrical machines. In order to improve them further, sophisticated experiments are being conducted by scientists of the firm in many areas of metals science, aerodynamics, thermal physics and other branches of science. As a result, most modernized units are constructed on the basis of fundamentally new technical designs, with each machine incorporating five or six inventions.

After the fabrication of a new unit, the usual course of events in the resolution of a problem of this magnitude is to wait for the assembly of the equipment at a station, put it into operation and to conduct comprehensive research during normal operations, all of which on the average takes 2 to 3 years. Above all, this amounts to postponement for that period of the beginning of serial production of the new technology. A few years ago a new stand was built at the association which has no equal anywhere else on earth. It permits preliminary operational testing under full load of machines with capacities of up to a million kilowatts each, to discover the shortcomings which are unavoidable in the process of producing similar equipment, and to effectively eliminate them. Users receive machinery that is ready to go, and which does not require any operational refinements, and the association gets the chance to set up immediately the smooth production

of more progressive equipment and to remove obsolete models from production. Cryogenic generators will be designed and built in the same way.

The scientific research institute and the design division are united by common economic interests. The results of their managerial activities are directly connected to the final results of the work of the entire enterprise. This is why every subdivision has an interest in overall success.

Underutilized capacities for increasing the effectiveness of the scientific and production research of the firm are far from exhausted, in the opinion of the association director. The experiment in improving the wages of designers and technologists which is now being conducted at "Elektrosila" will help to utilize these reserves more fully. These measures are designed to stimulate economically the creative activity of the designers of new equipment and progressive technologies, the development of which is the aim of a resolution of the CPSU Central Committee and the Soviet government.

9276

CSO: 1822/53

NON-NUCLEAR POWER

SMALL-CAPACITY THERMAL PLANTS FOR ECONOMICAL WATER HEATING, STEAM GENERATION

Moscow EKONOMICHESKAYA GAZETA in Russian No 45, Nov 83 p 15

[Article by N. Rassudov and N. Shestakov, associates of the NPO [non-governmental organizations] TSKTI [Central Boiler and Turbine Institute] imeni I. I. Polzunov, and I. Chernenkov, associate of the fossil fuels institute: "The Effect of Small TETs; A Suggestion That Does Not Deserve to be Forgotten"]

[Text] The energy generation capabilities of kolkhozes and sovkhoses is increasing with each passing year. Simultaneously, the numbers are also increasing of personnel for the servicing of the rural heat and energy generating complex. More than half a million people are currently engaged in this activity. How to get by with a lesser number of workers? Not a simple problem. Let us look at a couple of its aspects.

In the production plans for energy generation equipment there has been a significant increase planned for the output of small-capacity boilers, basically those generating up to 1 ton of steam per hour. During the current 5-year plan the factories of Minenergomash are planning to manufacture 60-70,000 boilers. Roughly 250,000 people will be required to service these alone. Similar numbers of boilers are also being produced at the factories of other departments. In the past year, for example, the factories of five ministries have produced 160,000 boilers. To this the 500,000 boilers which are already operational in the sovkhoses and kolkhozes of the country should also be added.

By way of background, back in 1970 a group of researchers at the Central Boiler and Turbine Institute imeni I. I. Polzunov had formulated a justification for the advisability of the utilization of simpler thermal electricity generating plants (TETs) outfitted with backpressure turbines instead of central boiler rooms. One of the important advantages of similar plants is that they assure savings in the consumption of petroleum products. Unfortunately, at that time this proposal did not receive wide support since fuel was cheap, although even then no one disputed our point of view. We therefore consider it necessary to return to this idea.

The simpler TETs of the submitted design, with a capacity of 50-150 gigacalories per hour, essentially represent boiler rooms with rotating pressure

regulators. All basic and auxiliary equipment is produced by factories. It can reach the customer in the form of transportable block units or modular units ready to be assembled at the place of installation. Such TETs may be put up on the same foundations and in the same periods of time as boiler rooms, with some minor supplementary site development.

The construction of TETs instead of boiler rooms is not only not connected with increased capital expenditures. If certain conditions are met they offer significant resource economies.

Recently, a group of researchers was acquainted with the heat and electricity generating requirements at kolkhozes and sovkhoses in the Leningrad and Irkutsk oblasts and in the Altay kray. Basically, in these locations centralized heat supply systems have been set up, while at the same time there are many smaller cast iron water heating and steel steam boilers. Along with the clear advantages of centralized supplies of heat and electricity, its shortcomings are also becoming evident. In the Irkutsk oblast, for instance, under severe winter conditions there were several disruptions in the flow of electrical energy because of accidents in the high-voltage grid during snowstorms.

For this reason independent, reserve sources of heat at certain kolkhozes and sovkhoses must be available. In our view, particular attention is merited by a variant consisting of the installation at central farms of gas generator equipment running on agricultural production wastes.

Similar gas generators are widely used in many countries, such as India. In our country a certain amount of experience has been accumulated in the use of small capacity gas generators with fluidized bed steam-jet operation. Low quality coal, peat and wood chips may all be burned as fuel.

The level of contemporary knowledge makes it possible to manufacture portable gas generators with external diameters up to 3.3 millimeters which are equivalent in terms of heat production capability to DKVR-6.5-13 and DKVR-10-13 boilers. For smaller users it is advisable to set up the serialized production of water heating and steam and water heating boilers fired by gas which do not require supplementary personnel for smooth operation.

In the opinion of Lithuanian energy generation experts a system of batteries can serve for providing hot water for the farming and living needs of the rural and urban population, for the heating of rural living quarters and also in the application of heat to production requirements at agricultural facilities. This experience can become a good supplement for other variants of economical heat and energy supplies for kolkhozes and sovkhoses.

9276

CSO: 1822/53

NON-NUCLEAR POWER

BRIEFS

POWER LINES GO UNDERGROUND--(TASS)--In many Lithuanian villages the electric power line poles are disappearing: the electric power lines (LEP) here are "going underground." A mobile tower of energy generation industry employees has put just such underground communication lines into operation at the Mosedis kolkhoz of the Skuodas rayon. They are "hidden away" in the ground at a depth of 1.5 meters. As a result of this operation, the kolkhoz received some additional land that had been occupied by the LEP poles. For the laying of these underground electricity lines the builders utilize cable the production of which is handled by the Shyaulyayskiy factory of the Energostroy trust. "Construction of underground LEP on a republic scale will make it possible to return to agricultural use thousands of hectares of arable land," said the deputy director of the Main Energy Generation and Electrification Directorate of the Lithuanian SSR, A. Stumbras. "This represents a substantial contribution by the employees of the energy generation industry to the implementation of the food program." [Text] [Moscow STROITEL'NAYA GAZETA in Russian 5 Oct 83 p 1] 9276

HIGH VOLTAGE RING COMPLETED--(TurkmenINFORM)--The energy supply situation has become more hopeful for the enterprises of the agro-industrial complex of the Tashauz oblast. Here there has been constructed under load a 7 kilometer LEP-110 connecting the Tamauz and Yuzhnaya substations. This marks the completion of a multikilometer high voltage ring which receives current from the Takhiatash hydroelectric power station and the energy generation systems of the Khorezm oblast. The ringing of energy generation flows is a new stage in the electrification of an oblast that does not have any powerful electrical generating stations. This makes it possible continuously to supply current to users even in the event of an accident to one of the participants in the ring: the energy simply routes itself along a reserve LEP. Only this year have operations begun at the second series of substations at Takhta, Teza-Bazara and the sovkhos imeni Zhdanov in the Tel'man rayon, and on the Tashauz-Takhta LEP. The overall length of electrical transmission lines in this oblast is currently about 7,000 kilometers. [Text] [Ashkhabad TURKMENSKAYA ISKRA in Russian 25 Oct 83 p 3] 9276

POWER LINES CROSS IRTYSH RIVER--Semipalatinsk--A permanent energy supply is being provided to the Beskaragay rayon by a new high voltage line with a tension of 110 kilovolts. The sovkhos Semiyarskiy was the first to hook up to it. The newly operational segment of the LEP stretched for all of 40

kilometers. But it would be difficult to overestimate its importance. Here, close to the village of Semiyark, construction is proceeding of the largest irrigated area in the east of Kazakhstan, covering 80,000 hectares. The irrigation will be provided by the waters of the Irtysh river with the assistance of a powerful pumping station. According to the calculations of the designers, the soil improvers will become the primary users of energy in this rayon. Previously the energy came from Semipalatinsk. Once the new line is installed, it will come from Pavlodar. A collective from the Kazelektroset'stroy was able to finish all of the necessary work ahead of schedule. The greatest difficulty for the construction crews was the construction of the poles on the banks of the Irtysh and the stringing of the line across the river. A high degree of professional competence and extensive experience helped the builders to cope with all of the problems that faced them. They celebrated the 66th anniversary of the great October with the successful completion of this assignment. The laying of the lines is continuing. From the new substation near to the irrigated area the poles march far into the steppe to the village of Novonikolaevka. The length of the final segment of this energy bridge is 70 kilometers. As early as next year all facilities on the Beskaragay rayon will begin to receive energy from two sides--from Pavlodar and from Semipalatinsk. This will make it possible to develop more intensively all aspects of agriculture. [Text] [Article by L. Reznikov] [Alma-Ata KAZAKHSTANSKAYA PRAVDA in Russian 22 Oct 83 p 1] 9276

GUR'YEV-KUL'SARY POWER LINK--Gur'yev--A new LEP-220, the laying of which has been completed by a collective of the Sredazelektroset'stroy trust will help to increase the energy balance of the developing Transcaspien oil and gas bearing region. The 150-kilometer Gur'yev-Kul'sary power generating link will assure the guaranteed delivery of current to the oil industry workers and drillers of West Kazakhstan, expanded prospecting for and extraction of oil and gas. "It was not easy for the builders to manage things within the allotted deadlines," relates the chief engineer of the Gur'yevenergo directorate, G. Pospeshil'. "The poles for the power link had to be located in loose sand and carried across ravines. Forty-five degree [Centigrade] heat, strong winds and dust storms forced the builders to come up with new engineering solutions. Where possible they replaced the excavation of foundation pits with drilling and used reinforced concrete poles, which are easier to assemble, instead of the more expensive metal poles." The Gur'yev-Kul'sary LEP will become a permanent segment of the energy supply system of Western Kazakhstan where, according to resolutions of the 26th CPSU Congress, there will be an expansion of oil and gas extraction and intensified prospecting for new fields. [Text] [Article by V. Sutyagin] [Moscow SOT-SIALISTICHEKAYA INDUSTRIYA in Russian 4 Nov 83 p 1] 9276

CSO: 1822/53

PIPELINE CONSTRUCTION

CONSTRUCTION OF PIPELINES FROM URENGOY PROGRESSING

Moscow SEL'SKAYA ZHIZN' in Russian 12 Jul 83 p 1

[Article by M. Sil'vanovich (Novyy Urengoy, Tyumen Oblast): "Urengoy's Gas"]

[Excerpts] Not many rivers in the land flow from the north. Urengoy, a gas field on the Arctic Circle, has already given life to four during the current five-year plan alone--these are the rivers over which the "blue fuel" flows to Gryazovets, Petrovsk and Novopskov. The fourth, the gas-export pipeline, flows from West Siberia to Western Europe. This river is 4,451 kilometers long just to Uzhgorod. And already the first 1,043 kilometers of the channel's terminal section are operating. Gas has gone to the Urals.

Integrated Gas Treatment Installation (UKPG) No 9 can be called the source of this river. It was the first to transmit "blue fuel" into the friendship arterial through the terminal compressor station. Last Saturday a meeting attended by many people was dedicated to this event.

The tundra of the Arctic Circle is becoming increasingly inhabited. Ever newer towns and settlements of rotating-duty workers are rising up along the right-of-way. The field's capital--the city of Novyy Urengoy--accommodates first-class airliners at its airport, its streets are being developed with 9-story "Leningrad" buildings. The city intersects the railroad that was just recently called the Tyumen BAM [Baykal-Amur Mainline]. Trains carrying pipe, constructional structure, equipment and machinery pass over it at a height, it seems, of five stories--the fill of the steel roadbed is so high. From Novyy Urengoy to UKPG-9 is a trip of 1½ hours by bus. En route one can see all eight field facilities that feed the operational trunk gas pipeline systems at full load. The export arterial receives gas from the ninth. UKPG-9 is distinguished from its eight predecessors by more modern equipment. In a short time it will send daily into the gas river 60 million cubic meters of the natural fuel. The turnover of a 10th field facility is nearing--each of them is a new step toward Tyumen's billions.

But meanwhile, pipelinebuilding subunits are already welding joints on the following strand--Urengoy-Tsentr-1, and on the next, the sixth, gas pipeline for the current five-year plan--Urengoy-Tsentr-2.

11409

CSO: 1822/86

PIPELINE CONSTRUCTION

BULGARIA-USSR PIPELINE CONSTRUCTION PROGRESSES

Moscow STROITEL'NAYA GAZETA in Russian 9 Sep 83 p 4

[Article: "Construction of the USSR-BNR Gas Pipeline"]

[Text] One of the bright manifestations of Bulgarian-Soviet friendship is the successful realization of the agreement on the delivery of Soviet natural gas to our country and the construction of the USSR-BNR [Bulgarian People's Republic] gas pipeline.

Construction of the first stage--the northern semiring--was completed in April 1974. Within a year, erection of a compressor station for the gas pipeline was completed at Brestak village, Varna Okrug.

During the construction work, the installing administration GazstroyMontazh [Administration for the Construction and Installation of Gas Industry Facilities], under director Hero of Socialist Labor engineer Stoyanovich, successfully overcame the difficulties that arose, because of experience gained and the increase in construction, at Bozhurishte village, Sofia Okrug, and it became Bulgaria's first specialized gas-pipeline construction organization. The high quality of the work done during construction of the gas pipeline's first stage confirms the qualifications and the professional skills that the installers had attained, announced Boris Barabash, supervisor of the specialists' group.

In order to raise the percent of use of gas in accordance with a decision of Economic Mutual Assistance decision, we worked out a program for expanding and intensifying gas pipeline systems, said Deputy Minister of Chemical Industry Engineer Georgi Dimov.

This construction is being performed in two stages. During the first stage, the southern portion of the gas pipeline was built from Brestak village of Varna Okrug to Zagoravillage of Staraya Zagora Okrug, with branches to Staraya Zagora and Dimitrovgrad and to Ispirikha, Shumen and the Varna TETs. During the second, current stage, the gas pipeline is being built from Staraya Zagora to Sofia, to close the gas-pipeline system. A joint socialist competition, "Druzhiba," between Bulgarian and Soviet workers and specialists who are working on the trunk gas pipeline, is being promoted. During the first stage of the competition, the Bulgarian specialists and installers from the specialized administration of Bozhurishte village won.

11409

CSO: 1822/85

PIPELINE CONSTRUCTION

TOO MUCH PIPE, EQUIPMENT ABANDONED ALONG RIGHTS-OF-WAY

Moscow SOTSIALISTICHESKAYA INDUSTRIYA in Russian 26 Mar 83 p 2

[Article by Yu. Belanov (Tobolsk-Surgut-Tyumen): "Abandoned in the Taiga"]

[Text] "Millions of tons of pipe, metal structure and other expensive things are imported into the Tyumen North. Unfortunately, not by far are they always used thriftily. In order to be convinced of this, it suffices to follow the Tobolsk-Surgut railroad, along which Minneftegazstroy [Ministry of Construction of Petroleum and Gas-Industry Enterprises] subunits laid several pipelines 5 years ago. There you will see such..." (From a letter by Tobolsk Engineer I. Bondarenko.)

And now it is summer on the route suggested by the reader. At our request, the helicopter commander flies his rotary-winged vehicle as low as possible along the right-of-way corridor in which, during the 10th Five-Year Plan, the Nizhnevartovsk-Kurgan-Kuybyshev, Surgut-Polotsk, Urengoy-Chelyabinsk and other pipelines were built. The Yuzhnyy Balyk-Tobolsk product pipeline also was turned over for operation here in 1981.

About 60 kilometers from Tobolsk we begin to run across the remains of equipment discarded by builders many years ago: the cab of an excavator with a boom, parts of machinery, a tractor half-frozen in the swamp....Here in the Ob taiga there are as many concrete hold-down weights as you could want--just thrown away. And everywhere there is pipe, pipe and more pipe.

"Some of them are ours," senior engineer of the engineering section of Surguttransgaz [Surgut Gas Transport Association] M. Kunin explains. "They are those, you see, that are intended for repair and for case of an emergency."

You do not confuse an emergency pipe reserve, which is laid in stacks, with abandoned pipes, which are scattered fanlike at the edge of a forest clearing. Here is the Salyk oil-transfer pumping station. More than 20 oil pipes have been thrown away here. Some of them are even welded into pipelengths. Six large-diameter pipes intended for gas-pipeline laying have been thrown away on a segment of the right-of-way in the area of the Pyt-Yakh Railroad Yard. Alongside one of the compressor stations (KS's) is a graveyard of abandoned

pipe. Those who tend the station decided to put them partially to work--they put several pipes across streams, filled their ends with sand and got a convenient bridge. They have tried to count up the number of discarded pipes--but no, it did not happen, there were too many of them....

Choosing a suitable patch for a landing, the helicopter commander let Surgutneftegaz [Surgut Oil and Gas Production Association] engineer V. Odiyanov record on film the traces of the extravagant builders. And, while the camera's shutter clicks, I walk over to one of the large-diameter pipes--they are needed very badly today on the new routes. While here they have been thrown away as unnecessary trash.

Just who is guilty of the irresponsible attitude toward the people's property? I went to Minneftegazstroy's Main Production-Management Administration (GlavPRU), to the branch's staff for the Tyumen North, for an answer to this question.

GlavPRU chief N. Kizub explained to me, "Subunits of Moscow's Glavtruboprovodstroy [Main Administration for Pipeline Construction], Ufa's Glavvostoktruboprovodstroy [Main Administration for Pipeline Construction in the Eastern Economic Region] and a number of other collectives worked in the 'corridor' route between Tobolsk and Surgut. But right now, with so many years having passed, it is impossible to tell at all who is the owner of one pipe or another."

Come on, Nikolay Ivanovich, you'r kidding. There is one owner of all these brooks that each year build a river of wastefulness: GlavPRU. The people who have been charged with standing, figuratively speaking, on the "captain's bridge," have to answer primarily for redeploying material valuables.

"People's controllers have made repeated surprise inspections and directed the supervisors of Minneftegazstroy's administrations, trusts and main administrations to impose order quickly," says deputy chairman of the oblast's people's control committee Yu. Sanin. "Thanks to the intervention of party committees of northern cities, many pipes have been hauled from existing routes. But, as you see, not all of them by far. The work must be continued, since such a matter cannot be bypassed with one-time campaigns."

Or by some orders and directives, however menacing they may be. What is needed is not a quotation of clever sayings to the effect that the economy should be economical, but practical implementation of them--to remove from facilities that were built long ago everything that can be removed, that has not yet been buried in the swampy quagmire. The most important thing--a set of carefully thought out measures--is needed that will themselves enable the elimination of pipe and other things being left on a pipeline that has been laid. For example, it is up to the operators not to sign for the general contracting trusts the state commission's certificate of acceptance for operation of the product pipeline between the Yuzhno-Balyk gas-treatment plant and the Tobolsk Oil-Refining Combine, until the Muscovites (Glavneftegazstroy [Main Administration for the Construction of Oil and Gas Industry Facilities]) and the Orenburgers (Vostokspetsgazstroy [Administration for the Special Construction of Gas Industry Facilities]) impose order instantly at their facilities. This means a businesslike eye, exactingness, and economic levers that are brought to bear.

"He who does not save kopecks will not be worth a ruble," the people's wisdom says. I recall it because Minneftegazstroy is charged during the current five-year plan with laying six of the largest of gas pipelines and many hundreds of kilometers of oil arterials. And it must carry out these most important operations not at any price but with the least cost. And this is why I am confident that the industry's staff will find an effective method for gathering valuable materials from the Tobolsk-Surgut corridor, over which we flew at the reader's request.

11409

CSO: 1822/85

PIPELINE CONSTRUCTION

BACK-UP CROSSING OF DNIEPER BUILT ON EXPORT GAS PIPELINE

Kiev PRAVDA UKRAINY in Russian 29 Sep 83 p 1

[Article by V. Luk'yanenko (Cherkassy Oblast): "With a Double Guarantee"]

[Text] Still another inverted siphon crossing of the export gas pipeline connects the Dnieper's shores.

"Left, left!" The load on the winch is 20 tons...."How is the inverted siphon?" they ask over the radio.

"The inverted siphon is moving!" Yu N. Zolotovskiy, chief engineer of Specialized Underwater Engineering Operations Administration No 5 (SUPTR-5) answers laconically.

The first length of pipe, with a sealed cap, on which, "Let's go, Dnieper!" had been boldly traced, moves out smoothly under the water, moving aside the white, really clean bottom sand that a suction dredge had thrown onto the shore. The pipelayers' tracks thunder in businesslike fashion. Launches and motorboats scurry between the river's banks.

Both these people and these machines were here about a year ago at Prokhorovka, close to Kanev, when they made the first inverted-siphon crossing for the Urengoy-Uzhgorod export trunk pipeline. Now they are laying a reserve inverted siphon--it will double the guaranteed reliability. This steel strand, like a constricting waistband of the Dnepr, between the Kremenchug and Kanev reservoirs, actually marks the concluding underwater operations on the gigantic route. The complicated but routine work that the underwater workers from SUPTR-5 are doing, which is constantly being recorded at Aksay, Rostov Oblast, is today filled with responsibility and a special feeling that the "last nail" is being driven--moreover, almost a year ahead of the planned deadline.

"We are ahead of schedule because we are striving to do everything conscientiously," says pipeline-segment superintendent V. G. Zheleznyak.

In the race against time, the hold-down weights and the fastening bolts, which were laid out on the pipe in good time, were on the side of the underwater workers. And, finally, there were the rapidity of the decisions that were adopted, the dedicated will, and the teamwork.

We see this teamwork here right now in the work of pipelayer operator V. S. Sirotyuk and winch operator M. S. Kartynnik. Speaking without exaggeration, it is their nerves that join the shores until the pipe bundle is lying on the bottom, when the winch has just started to swallow the thick cable that pulls the inverted siphon. They must understand the slightest deflection of the cable, a lowering of the load, and the behavior of the pipe, so that the 300-ton siphon does not go to the side or get buried in the shoulder of the ditch.

But, unfortunately, at the start of the dragging, when a weak spot of the cable was taken in, it clanked and, like a snake, it went into the water. A break.

A broad-shouldered giant, A. M. Yerokhin, heads for his diving gear. Yu. N. Zolotovskiy jumps from the motorboat, and, while on the move, opens a brief discussion.

"Shall we send a diver down?"

"It'll take too long".

"Or pull out the other end?"

"That'll mean re-doing everything..."

And everyone--from brigade leader G. V. Andreyev, the divers' foreman, to Gennadiy Lipnitskiy, who came to SUPTR-5 on a Komsomol work ticket--offers suggestions.

"So, let's 'trim' the cable with the pontoon," the chief engineer summarizes the ideas. "Working together, we shall check on whether it is lying well."

The check proved to be superfluous. Gennadiy Vladimirovich (although he was not in diver's gear) plunged in, taking off the cable black meters-long submerged logs--oaken trunks that had been lying peacefully on the bottom since the time of the Zaporozhe Host. The brigade leader kidded:

"We have a logging operation here."

However, he knew better than the others that such a thing cannot be encountered at the 16-foot depth. During his many dives he has seen diverse submerged logs and granite rocks that slow down the siphon, and enormous bones of prehistoric creatures--many of them are preserved in the river's sand. And he kidded because there was no reason for dejection--he believed in his own strength and that of his comrades. Each of them indeed was a man of many talents. Suction-dredge captain V. L. Bragar', for instance, is a bulldozer operator, a welder and a motor operator, and M. S. Kartynnik is an equipment operator, a driver, a launch operator and a sling man. They are like a bundle--the alpinists have a name for such a group that is going to tackle the peaks. The builders of underwater pipelines also make up a bundle and their summit is the inverted siphon, from scratch to turnkey turnover.

...Five days after the start of the pulling, the cap with the half-worn inscription appeared from the water at the right bank. It was not met with a "Hurrah!"--the job is customary. But still these were solemn minutes, because this next time the underwater workers had cut the passage by 2 days.

Under the searchlight, the motorboat bumped into the shore. Gangplanks squeaked. The people returned home. However, to define it precisely, this is an all-encompassing human concept--one's own home. Here, let's say, is superintendent V. Zheleznyak's house. He has relatives in Baku, and that is where his institute is, but his apartment is in Aksay. His family has been roaming now for 7 years--with him. This year they have even started a kitchen garden in back of their field dwelling. The strawberries were excellent....

In all, the Aksayers have laid 34 kilometers of pipe on the Dnepr's bottom. The fact that the linear portion of the export gas pipeline has been turned over ahead of time is of no small credit to the underwater workers, who have duplicated today one of the most complicated sections.

11409
CSO: 1822/85

PIPELINE CONSTRUCTION

MULTILAYER HIGH-PRESSURE PIPE PASSES TEST; PROBLEMS OF FIELD USE REMAIN

Moscow STROITEL'NAYA GAZETA in Russian 24 Jul 83 p 2

[Article by A. Zhdanov (Tyumen): "After the Test"]

[Text] In the fall of last year, not far from Beloyarskiy village, which is lost amid taiga and swamp in the north of Khanty-Mansiyskiy Autonomous Okrug, tests were completed that were of basic importance to a further increase in the volume of transporting of Siberian natural gas and to the industrialization of pipelinebuilding. Here at a looping of the Urengoy-Novopskov gas pipeline, a 4-kilometer section of domestic pipe of a new type--multilayered pipe of greater strength--has been built and tested successfully.

"As is well known, we are now laying gas pipeline made from pipe designed for a pressure of 75 atmospheres," says S. Vel'chev, chief of the engineering administration of Glavsibtruboprovodstroy [Main Administration for Siberian Pipeline Construction]. "One of the paths recognized as most promising for increasing gas delivery to the national economy is to increase the operating pressure in the trunk pipelines to 100-120 atmospheres. It is just such a pressure head that the new pipes created by scientists and specialists of the Institute imeni Ye. O. Paton are called upon to subdue. At Beloyarsk these pipes sustained a pressure of 126 atmospheres and completely justified the hopes of the creators...."

Introduction of the new pipe into practice in building our gas-transport arteries promises great advantage. It is estimated that if the gas is pumped at a pressure of 100 atmospheres, then two instead of the traditional three "75-atmosphere" strands can be laid. An increase to 120 atmospheres will permit the erection of only one gas pipeline instead of two.

The construction of fairly large segments of line within Tyumen Oblast from multiple-layer pipe will be an important step on the way to its introduction. In accordance with Minneftegazstroy [Ministry of Construction of Petroleum and Gas Industry Enterprises] measures, their total length by 1985 should be 300 kilometers. One hundred of these kilometers are to be laid in the next right-of-way season, that is, fall-to-spring of 1983-1984.

Glavsibtruboprovodstroy is actively preparing for the responsible job. It has already been decided who will do the actual work--Severtruboprovodstroy [Trust

for Pipeline Construction in the Northern Economic Region] and Kazymtruboprovodstroy [Kazym Pipeline Construction Trust]. Two experimental flow-line construction groups are now being formed from their brigades. NIPIOrgtekhneftegazstroy [Scientific-Research and Design Institute for Organizing Industrialized Methods for Constructing Oil and Gas Industry Facilities], in accordance with a task assigned by the main administration, is developing standardized engineering documentation, and, at the same time, the flow-line operating groups' requirements for machinery and mechanisms are being calculated.

In brief, continuation right on the line of the large-scale experiment that was started at Beloyarsk is not far off. And already today a number of problems which, if not solved, will make effective introduction of the innovation difficult, are obvious.

...A conversation with members of A. Bragin's brigade from Kazymtruboprovodstroy during laying of the test segment is recalled. Even then the installers felt that it was practically impossible to achieve the ordinary pace because of the increased amount of welding: the wall thickness of the new pipe is 22.8 millimeters versus the ordinary 16-18 millimeters. The greater the thickness, the more time spent welding the joint. Calculations made after completion of the work by Orgtekhtruboprovodstroy [State Trust for Organizing Industrialized Pipeline Construction] indicated that this "more" is extremely appreciable: the welding of one joint of the strand of multiple-layer pipe, even by highly skilled workers, averages 1½-fold longer. That is why the problem of automating the welding is becoming especially sharp in the work with the new pipe. In order to solve it, in the opinion of the trust and the main administration's specialists, installation of the electrical resistance-welding unit Sever with increased power-equipment output--from 600 to 1,000 kW--can be completely suitable. The power must also be increased 1½-fold on the stands for rotary welding, where the pipe is joined into lengths. As before, the right-of-way workers here are hoping for active assistance from the Institute imeni Ye. O. Paton and the manufacturing plants.

Also, the urgency of improving insulating work is growing in the case of the new pipe. Bringing it to the line the way that it is being done in most cases today is becoming extremely unsuitable because of the increased weight of the multiple-layer pipe. One meter of it weighs 820 kilograms, 227 more than a meter of ordinary pipe. And if the multiple-layer pipe is insulated under field conditions, then a considerable increase in the number of pipelayers and other equipment will be required for this purpose.

A single way out is seen--maximum transfer of the work of insulating multiple-layer pipe to plant shops. A step in this direction is already being taken at the Vyksa Metallurgical Plant. The same insulating equipment used on the right-of-way has been installed alongside the industrial lines that produce the new pipe. However, this is a temporary, and inefficient, solution. For the insulation with which the plant worker covers his product is a film insulation. It is not adaptable to lengthy transporting, and it is not a short trip from Vyksa to the North of Tyumen.

The most optimal option is that of covering the pipe with a stronger and more reliable insulation, one made of polymer materials. The construction of a

section for coating multiple-layer pipe with such polymers has been planned for the five-year plan, at that same Vyksa plant. The erection of this facility and assimilation of the new technology requires the most tireless attention of USSR Minchermet [Ministry of Ferrous Metallurgy] and USSR Minkhimprom [Ministry of Chemical Industry], who have in the past clearly underestimated the importance of transferring the insulating work to plant shops.

The prospects for using the new pipe also present increased demands on the creators of transport equipment.

Everyone knows the "Uragan" well, but the engine life of this high-powered vehicle is too slight--about 650 hours. In other words, with intense use, it will serve only a month and a half. As experience indicates, during this period the Uragan can haul from the pipe-welding bases to the right-of-way, all told, 3-4 kilometers of pipe. Right now the line workers have taken this step: it has been decided to place K-701 tractor engines on several Uragans. It is difficult to say yet how such a hybrid will behave in operation. But there is no doubt that more reliable vehicles are needed.

Something should be said specially about still another problem. This is the erection of the compressor stations on lines erected from the new pipe. It is planned to erect four of them. It is clear that if the arterial is designed for 100 atmospheres, then the compressor station also--its operating pipelines, its shut-off fixtures and so on--should also be made for the same pressure. How should this be done? There is no clarity here yet. And that is why the general designer, YuzhNIIGiprogaz [Southern Branch of the All-Union Scientific-Research and Design Institute for the Design of Gas Pipelines and Gas Industry Enterprises] and its related entities, as well as the manufacturing enterprises, should speed up work in this area.

11409

CSO: 1822/85

PIPELINE CONSTRUCTION

PREPARATIONS START FOR THIRD PIPELINE ACROSS NEVEL STRAIT

Moscow IZVESTIYA in Russian 10 Jun 83 p 1

[Article by B. L'vov and G. Panushkin: "Again Across the Strait"]

[Text] Construction of the Okha-Komsomolsk-na-Amur gas pipeline is starting.

Preparations for the construction of still another large pipeline in the Far East is in full swing. The new trunk line is taking its start close to Okha, on Sakhalin Island, to cross Sakhalin's Nevel Strait. And the time is not far off when hundreds of millions of cubic meters of gas will begin to go over the new transport artery to the region's large industrial center--Komsomolsk-na-Amur.

The work is not easy, either for the machinery or in terms of production technology. However, it is nothing new to the builders: they will be treading this difficult path for the third time. But this does not at all mean that a repetition of the path that has been trod will be more accessible, or simpler. Ahead are the taiga ravines and cone-shaped hills of the Amur region and the forced crossings of rivers, swamps and the most complicated obstacle--the 7-kilometer Nevel Strait, which is known unflatteringly for its capricious "disposition."

It brought the builders of the first arterials--oil pipelines from Sakhalin to Komsomolsk--much trouble. The starting of the route, which was laid 40 years ago, in the wartime years, and depicted so brilliantly in Vasiliy Azhayev's novel, "Far from Moscow," which was later made into an artistic film, is considered a glorious labor epic.

And now Glavvostoktruboprovodstroy [Main Administration for Pipeline Construction in the Eastern Economic Region] collectives are to repeat the feat of their older comrades. Soon the first mechanized columns of this large regional main administration of Minneftegazstroy [Ministry of Construction of Petroleum and Gas Industry Enterprises] will again go out to the Far East's expanses, from the village of Lazarevo, to Komsomolsk-na-Amur. Ministry of Gas Industry subunits will "straddle" the right-of-way for the remaining sections, including the Nevel Strait. The gas pipeline, more than 600 kilometers long, will promote development of the district's fuel and power base.

11409

CSO: 1822/86

PIPELINE CONSTRUCTION

BRANCH GAS PIPELINES BEING BUILT TO MANY MORE CITIES

Moscow SOVETSKAYA ROSSIYA in Russian 20 Oct 83 p 1

[Interview with G. S. Chesnokov, deputy chief of the Main Production-Management Administration of Minneftegazstroy, by A. Avdeyev: "Urengoy's Trunk Lines"]

[Text] The number of customers for Siberian gas is being multiplied.

Four high-capacity gas pipelines join Tyumen Oblast's North with the country's central and western regions. Work is in full swing on a fifth trunk line. Materials and equipment are being imported for a sixth. In their letters, readers ask: where are the additional billions of cubic meters of gas obtained from Urengoy now being used? What kinds of communities and enterprises will become its customers? Deputy chief of the Main Production-Management Administration of Minneftegazstroy [Ministry of Construction of Petroleum and Gas Industry Enterprises] G. S. Chesnokov answers these questions.

"It is not without reason that they talk about natural gas, which is the least expensive and most reliable fuel, and the one least damaging to the environment. Today it is helping to smelt 93 percent of the pig iron and steel and to produce 90 percent of the nitrogenous fertilizer and two-thirds of the cement. Each of the six Urengoy arterials will transport tens of billions of cubic meters of gas per year. This is equivalent to the transmission of 15-18 million kW of electricity, that is, more than all the GES's on the Angara and Yenisey generate.

"Readers are interested, of course, in the gas supply for apartments. More than 200 million of our country's residents are using natural gas for household purposes. Let us take a list of communities that were connected last year to the unified gas-supply system. Alphabetically, they were: Astrakhan, Balashov, Belinskiy, Beloretsk, Bronnitsy, Voskresensk, Globino, Desna, Yesentuki, Ilovaysk, Nezhin....There were, in all, several dozens of names. To some of these communities, gas had come for the first time. At others the reliability of the residents' supply was increased, and the possibility of providing fuel for a number of large enterprises appeared. For example, the Novosibirsk Electrode Plant, the Oskol Electrometallurgical Combine and the Kiev TETs.

"It is necessary to speak especially about city TETs's. In Moscow the complete conversion of municipal-services enterprises to gas enabled thousands of coal-fired boilers to be shut down. The capital's air became appreciably cleaner. Similar work is going on in many parts of the country. Branch lines are being built from the operational trunk lines. Their length varies--from several dozens to several hundreds of kilometers. The matter is not simple. The builders work, as a rule, in regions with a dense network of various utility and service lines and facilities. They have to cross railroads, highways and existing pipelines repeatedly. It would seem that you would not work up such a rapid pace in laying lines under such conditions. But the right-of-way workers even here demonstrated examples of shock work.

"From 4 to 5 kilometers--that is the daily 'step' of the Tatnefteprovodstroy [Tatar ASSR Pipeline Construction Trust] and Vostoktruboprovodstroy [Trust for Pipeline Construction in the Eastern Economic Region] subunits that are working on the construction of branch lines to the Nizhnekamsk industrial center. This line is 242 kilometers long. The deadline for introduction is October this year. More than 200 kilometers are ready for testing today. The welders, equipment operators and insulators are working well. The brigades' operations are being coordinated by the central staff of Glavvostoktruboprovodstroy [Main Administration for Pipeline Construction in the Eastern Economic Region]. Introduction of the line into operation will enable the entire heat and power systems of KamAZ [Kama Motor-Vehicle Plant], the GRES, two heat-and-electric-power centrals, and manufacturing activities to convert to gas. I will add: the city of Brezhnev will receive Urengoy fuel ahead of time.

"This year our subunits should complete work on many branch lines. Among them is the gas pipeline to the Karmanovskaya GRES in Bashkiria. More than 100 of the 137 kilometers of the line have already been laid here, and the Nefteprovodmontazh [Oil Pipeline Erection Trust] is not slowing the high pace of pipe-laying. The erection of a 33-kilometer branch line to the Kharkovskaya TETs is being completed. Everything is ready for tests of the 46-kilometer branch line to the Ulegorskaya GRES. Work is being promoted widely on the gas pipeline to Pechora's GRES; it will be 98 kilometers long.

"Each facility turned over expands the network of supply of the 'blue fuel,' enabling coal and mazut to be dispensed with."

11409

CSO: 1822/86

PIPELINE CONSTRUCTION

UDC 624.09.073-412 658.562

CONSTRUCTION OF HOUSING, AMENITIES IN NOVYY URENGOY

Moscow STROITEL'STVO TRUBOPROVODOV in Russian No 10, Oct 83 pp 25-26

[Article by V. G. Vasilenko, Urengoygazstroy Trust, Novyy Urengoy: "Centering Attention on Quality"]

[Text] Builders of the city of Novyy Urengoy are contributing greatly to the assimilation of the gas fields in Western Siberia.

The increase in gas production and, correspondingly, in the population of Novyy Urengoy made it necessary to expand the program of building housing, socio-cultural and personal service facilities.

The Urengoygazstroy Trust, established in 1980, is the general contractor for building the city. The trust collective built schools, a hospital, a polyclinic, housing, dining rooms, stores and kindergartens. All facilities were released with good and excellent evaluations.

The problems of improving the quality of construction are constantly at the center of attention of all engineers, technicians and social organizations of the Urengoygazstroy Trust. A Construction Quality Control Council headed by the chief engineer of the trust operates in the trust. The council consists of skilled specialists in the basic departments and chief engineers in the subdivisions. Quality control engineers and skilled specialists in departments, sections and brigades in construction administrations are included in the Quality Control Council.

The Quality Control Council develops and introduces standards for trust enterprises (STP); plans and executes measures to improve the quality of construction-installation work. The council also has the problem of publicizing the results of the quality control. For this purpose, the council organizes conferences, seminars, meetings, exhibits, photographic displays and issues information sheets, pamphlets and other materials on improving the quality of construction. The council inspects the quality of construction installation work and checks the correctness of the execution of documentation for the facilities being built not less than once a month. Results of checks are published at the proper time (formal documents are prepared, notes are

entered in work logs directly at the facilities being built). The council function also includes certifying the knowledge of principles of quality control of engineers, technicians, workers and employees.

Quality Days are conducted every quarter in the trust. Chief engineers in the trust subdivisions explain deviations from existing norms and regulations in observed infringements. The fulfillment of organizational-technical measures on raising the quality of construction is reviewed; summaries are made of the checks of the standard of production, the cleanliness of the facilities under construction; and the condition of warehousing and storing materials. Brigade leaders, foremen and site engineers who have received substantive criticisms from the inspectors are invited to the Day of Quality. A well-equipped construction laboratory functions in the trust which, besides physico-mechanical material tests, nondestructive tests of structures and products, also samples the quality control of structural-installation work in the manner established by operational control arrangements. The laboratory also selects the quality of concrete and mortars; checks the condition of the earth in foundations; monitors the observation of technological modes when working in winter, etc. The construction laboratory analyzed the work of the trust with respect to quality in 1982 and on the basis of the result of this analysis determined the degree of participation of all subdivisions and services of the trust in controlling construction quality.

Competitions like "Best in the Profession", "Golden Hands Master", as well as competitions for the best innovative suggestion to raise quality play a great role in the struggle of the builders to improve quality.

All work is carried out in accordance with a plan for measures to raise the quality of construction, coordinated with the technical administrations of the Glavurengoygazstroy and the Nadym territorial inspection on construction quality.

The plan includes measures to provide engineering training; to supply construction sites with materials and equipment on time; provide personnel training; improve the psychological and material aspects of the incentive system; and improve the construction quality control system now in force.

Achievements and shortcomings in the work on quality control and the fight against wastefulness and extravagance are displayed on "Quality display boards" of the trust and subdivisions, and "Quality displays" directly at the site under construction, as well as in the issues of KOMSOMOL'SKIY PROZHEKTOR printed by the trust and subdivisions. A technical bulletin is issued quarterly on the quality of construction.

In 1982, the trust held the first general technical conference on improving the quality of construction in which the following participated: representatives of all Glavurengoygazstroy trusts, quality control organs, customers and subcontractors. Implementation of the decisions of this conference facilitated the further increase in the quality of construction.

At present, a contract has been concluded with the Orgtekhstroy of the Glavurengoygazstroy to develop various STP for the trust. The use of standards will make it possible to improve all types of quality control existing at the construction facilities of the trust (input, operational, receiving, geodesic, inspection). At present, the standard (STP) "Samokontrol" is being introduced at the basis of which are: high responsibility for the entrusted job; raising the skill of the executors; combination of self-control of quality with periodical quality control. The standard specifies a quantitative evaluation of everyone's labor quality; awards executors for high quality work and standard of production; clear-cut organization and planning of work; creating labor conditions necessary for achieving high quality. In order to raise the quality of construction further, it is necessary to require more rigid incoming planning-estimating documentation; and utilize construction materials, products, structures, machines and devices efficiently. Improving the technology of construction, creating consolidated brigades and introducing the contract brigade are of great importance. Clear-cut organization is required to eliminate crash work which may lead to violations of the plans and the SNiP [Construction Norms and Regulations] .

COPYRIGHT: Izdatel'stvo "Nedra" Stroitel'stvo truboprovodov, 1983

2291

CSO: 1822/75

PIPELINE CONSTRUCTION

PREPARATIONS FOR WINTER PIPELINEBUILDING UNDER WAY

Moscow SOTSIALISTICHESKAYA INDUSTRIYA in Russian 2 Nov 83 p 1

[Article by Yu. Belanov (Beloyarskiy settlement, Tyumen oblast): "The Line Is Pushing on"]

[Text] When the holiday in honor of the introduction of the Tyumen segment of the Urengoy-Pomary-Uzhgorod gas pipeline into operation ahead of schedule passed along the 1,000-kilometer gas "street," even the Beloyarskiy outpost of Glavsibtruboprovodstroy [Main Administration for Pipeline Construction in Siberia] was decorated with scarlet netted signs. Kazymtruboprovodstroy [Kazym Pipeline Construction Trust], which is based in this workers' settlement, laid 180 kilometers of the export trunk line in 3 months.

But, as they say, a holiday takes an hour, the job takes time. The young trust's concerns are increasing. During the next winter season it is to lay 147 kilometers of pipe for the first strand of the West Siberia-Tsentr [Central Economic Region] gas pipeline and 230 kilometers on the second one. Moreover, about 100 kilometers of so-called loopings--additional gas-pipeline sections that increase the arterial's effectiveness--must be built.

It is scarcely light when I set out with Ye. Slutskiy, deputy trust manager for production, for the welding base. The vehicle, equipped with a radio, is a working office, except that it is on wheels.

"This is Three", some trust unit supervisor starts communications.

"That is Kazakov, chief of a section of SMU-25 [Construction and Installing Administration No 25]," says Slutskiy. "I hear you, Vladimir Pavlovich."

"Efim Borisovich, the defectoscopes have run out of X-ray film."

"Send a vehicle quickly to the warehouse: 30 kilometers of film have just been received."

In a minute, "Central" urgently calls "Three". Main administration chief engineer Gerdt is on the line.

Briefly, Slutskiy reports in businesslike fashion about the readiness of the trust's subunits for start of the line operations. Pipe has been brought in

almost completely for the gas pipeline. Brigades of the specialized road and transport-operations administration are completing the laying of a "corridor" for the arterial that is being built. More than 20,000 ballasting devices--hold-down weights--have been prepared.

The welding base greets us with hot flashes. A pipelayer has just loaded 18 large-diameter pipes into the storage magazine, and now the cutter-manipulator is delivering them to the assembly stand. Quickly and with precision the pipes are centered. The most important operation is starting--welding of the root joint. And then the pipelength goes to the rotating rollers, where the backing run of the "root" is performed.

I look at the clock: 25 minutes and the next pipelength is ready.

"About 80 kilometers of pipelengths have already been prepared here for the two gas-pipeline strands," says brigade leader A. Borodayev. "The new right-of-way is pushing on!"

A businesslike mood is sensed also within the trust's party committee.

"In all the field towns," states party committee secretary V. Karpov, "visual agitation has been rejuvenated. Skilled propagandists are doing much explanatory work about the tasks of the collectives and of each builder individually, which flow from the decisions of the July CPSU Central Committee Plenum. The most important sections of the line have been reinforced by party committee members."

Nice changes have occurred in the workers' settlements. Hundreds of families have already celebrated housewarmings in the 20 well-appointed five-story apartment houses. The lights of the Palace of Culture shine invitingly in the evening. Soon an athletic complex with a swimming pool will throw open its doors hospitably.

A rapid pace has been picked up in the pre-October competition in all sections on the new route. Each brigade is striving to greet the nationwide holiday worthily, and each is well prepared for start of the hard-work season--winter, when the main line operations will be developing.

11409

CSO: 1822/86

ENERGY CONSERVATION

AZERBAIJAN PLANS FOR MAXIMUM UTILIZATION OF ENERGY RESOURCES

Baku BAKINSKIY RABOCHIY in Russian 6 Sep 83 p 2.

[Article by M. Imanov, chief of the Main Production Administration of Power Engineering and Electrification of Azerbaijanian SSR: "Preparing for the Winter Test"]

[Text] It was pointed out at the June Plenum of the CPSU Central Committee that, in order to increase production efficiency, it would first be necessary to make rational use of everything we possess and extract the maximum yield from energy resources. The republic's power system is currently encountering a number of difficulties; however, we have considerable resources and possibilities for work improvement.

The fall-winter period is the most difficult for power engineers. It is in the full sense of the word a test of the power system, a crucial, difficult test for which all the system's links must be prepared with the utmost care.

Last winter, Azglavenergo keenly lacked capacity both in the power system itself and in the Transcaucasian power association as a whole. Under these conditions, the Azerbaijan power system was not at the proper level at the beginning of winter. As indicated at the plenum of the CPSU Central Committee of Azerbaijan, held in December of last year, the power system could not assure a reliable supply of electricity to the republic's economy.

Along with objective difficulties hindering power engineers in successfully passing the winter peak load were serious shortcomings in Azglavenergo performance; untimely and not always quality completion of repairs of basic equipment, nonfulfillment of tasks to output maximum capacity at some important thermal electric power plants; unsatisfactory organization of the control of power and energy demand. In the second half of the winter period we managed to achieve a definite improvement in power supply to customers and fulfillment of tasks according to the basic indicators of production performance. For the first time in the last 6 years, the system satisfied the demand for electric power with its own resources in the first quarter of this year, that is, without purchased power. We achieved this thanks to the early introduction of the power units of the Azerbaijan GRES [State Rayon Electric Power Plant].

However, whereas we attained self-sufficiency in electric power production, we still lacked roughly 14 percent of generating capacity to cover the peak load of the power system's users in that same winter period of 1982-83.

The USSR Soviet of Ministers took stock of the difficulties encountered last winter by the power systems of the Transcaucasus and by a special order determined the introduction of generating power at Azglavenergo for the 1983-84 winter period: the third 300,000-kw power unit at the Azerbaijan GRES in November and the second 190,000-kw hydroaggregate at the Shamkhor GES [Hydroelectric Power Plant] in September of this year. A section of overhead line transmitting electricity between the Azerbaijan GRES and Agdam substation will be built to output the capacity of the new power unit and will be completed next year. Construction of the republic's first 500,000-v power transmission line between the Azerbaijan GRES and Apsheron will also begin.

The USSR Soviet of Ministers obligated us to burn furnace mazut in the boiler chambers of the Azerbaijan GRES, which have always only burned gas. The laborious and complex reconstruction needed to realize this at the two operating power units will be completed before the end of the third quarter.

Before us is the task of eliminating the lack of capacity from the power units of the Ali-Bayramly GRES, caused by burning unrated mazut with a high sulfur content in the chambers of its boiler aggregates. As at the Azerbaijan GRES, reconstruction is needed here with the installation of power calorifiers, which increase the boilers' steam production and thus the capacity of the units, and extend their service time and inter-repair period. Such calorifiers have already been installed at three power units.

By utilizing to the maximum the system's available and new capacities at unit electric power plants and highly efficient thermoelectric power plants, we should achieve a further reduction under winter conditions of the specific weight of the still considerable inefficient power equipment in the production of electric power.

As never before, this year's repair program is very saturated. At thermal power plants alone, capital and intermediate repair was planned for 12 boilers and 11 turbines, two of which were from a large-capacity power unit. The repair of seven boilers, five turbines and one power unit has already been completed.

A large volume of repair work must be performed on all voltages of power transmission lines and transformer substations. Special attention is being devoted here to substation lines which supply oil recovery sites.

In the Lenin electric network, for instance, three substations supplying oil fields will be shifted to a higher voltage class, which will considerably increase the reliability of power supply and reduce power loss. At the

Zykh substation, an old transformer group, having served its time, will be replaced by a higher capacity modern transformer. At Mashtagi substation, from which the fields of the Azizbekovneft NGDU [Administration for Oil and Gas Extraction] receive their power, the obsolete overhead switches will be replaced by new more powerful ones.

Power engineers of the Ali-Bayramly substation, according to an agreement with oil men, have undertaken the capital repair of the lines and equipment of Muradkhanly and Padar substations. They also agreed to repair before winter the lines and equipment of five substations, the bus bars of which power the "Shirvanneft" industries.

Correctly organizing the management of electric power consumption is a matter of primary importance. The experience of the past winter showed that the schedules to limit power and capacity use developed by Azglavenergo's Energy Inspectorate, proved ineffective, as did control of their performance. The majority of the enumerated measures have already been taken.

The Azerbaijan Communist Party Central Committee plenum held in December of last year frankly indicated that ministries and departments should be more concerned with questions of rational power usage. Results are seen when there is concern for standardizing power resources, introducing technical measures to conserve energy and reduce capacity, and organizing competition for efficient power usage. Thus, in 1982 and the first half of 1983, the Azelektrosvet Production Association, NGDU imeni 25 Baku Commissars, Kirovabad Aluminum Plant and Baku Dry Transformer Plant, etc., conserved energy resources.

On the other hand, enterprises not devoting proper attention to introduction of measures assuring effective power usage allow its overconsumption. In the same period, 11 enterprises--the Sumgait Aluminum Plant, Azerbaijan railway, the Dzharly and Siazan Drilling Administrations and others overconsumed more than 37 million kw/h of electric power. A number of enterprises--the "Khimprom" Production Association, Azerbaijan Pipe Rolling Plant, Baku Iodine Plant, Bulk Yarn Factory and others allowed overconsumption of thermal energy.

Such enterprises as the Elektroshtamp Plant, Elektrotsentrolit Plant, Azerelektroterm Production Association, machine building plants imeni Dzerzhinskiy, imeni P. Montin and others underestimate the significance of wattless power compensation. In the first quarter of this year, numerous enterprises were forced to pay almost a million rubles in view of the surcharge on the rate for electric power for its underconsumption, caused by extra electric power losses.

Some heat users--the Sumgait Plant SK [not further identified], BNZ [Baku Petroleum Processing Plant] imeni the 22nd CPSU Congress, BNZ imeni Karayev and others consistently do not return the stipulated amount of condensate, for which large penalties are imposed.

Efficient power use depends very much on the users. For example, in order to reduce the peak load, it is important to transfer some of the enterprises to night shift work and for another group of plants and factories to establish Sunday as a working day with a day off in the middle of the week. Such mixing of peak power usage will help the power system get through the winter period. A measure such as capital repair of the users' energy-consuming equipment during winter would also serve the interest of reducing peak power usage.

The issue of preparing for winter was the subject of a serious, practical open discussion of the local Azglavenergo party organization. The meeting obligated communists and bound the whole collective to make every effort to prepare power systems for operation in the fall-winter period, and to provide unconditionally reliable and continuous power supply to the populace and economy of Azerbaijan.

12421

CSO: 1822/56

ENERGY CONSERVATION

MOLDAVIA CONSERVES ENERGY FOR THE PEAK FALL-WINTER PERIOD

Kishinev SOVETSKAYA MOLDAVIYA in Russian 21 Oct 83 pp 1, 3

[Article: "Prepare Reliably for Winter"]

[Text] The tasks of the party, soviet and managing organs to provide reliable power and heat supply for the economy and populace of the Moldavian SSR and conservation of heat and power resources in the 1983-84 fall-winter period were discussed at a republic conference held on 20 October in Kishinev. Directors of ministries, state committees and departments, secretaries of the party's gorkoms [city committees] and raykoms [rayon committees], chairmen of the ispolkoms [executive committees] of the city and rayon Soviets of Peoples Deputies and national control committees, the chief specialists of sectorial power services of Moldglavenergo [not further identified], and directors of enterprises which are large users of electric and thermal power were invited to the conference.

The conference was opened by Chairman of the Moldavian SSR Soviet of Ministers I.G. Ustiyani.

It was noted in the report of Deputy Chairman of the Moldavian SSR Soviet of Ministers P. I. Shapa and in the speeches of the directors of a number of ministries and departments and other participants, that considerable work was completed this year to prepare electric and thermal sources for the peaks of the fall-winter period. Measures are being successfully implemented to increase the winter readiness of electric power plant and network equipment and to repair buildings and structures.

Basically all ministries and departments have undertaken certain work to motivate collectives of industrial enterprises, construction sites, kolkhozes, sovkhozes and other organizations for the struggle to fulfill planned tasks for conserving fuel and thermal and electric energy and putting into production energy-saving technology and techniques, and scientifically based norms of fuel and energy consumption.

The majority of executive committees of the city and rayon Soviets of Peoples Deputies have opportunely examined questions of preparing for winter. The enterprises of Kishinev, Beltsy, Tiraspol, Kagul, Leovo, Rezina, Floreshty and other rayons are preparing systematically and consistently.

The necessity of working out permanent measures to reduce the consumption of electric power by enterprises during the peak load of the energy system was noted at the conference. A strong limit discipline by users and their observance of established conditions of power usage are an important condition of successful passage through the fall-winter peak loads. The main efforts must be directed to preventive work to deter overconsumption of thermal and electric power. Ministries and departments should take steps to conserve it at their enterprises.

Many problems must be solved to provide solid fuel to the national economy and populace of the republic. It was emphasized at the conference that there is still not enough machinery, loading equipment and storage areas to process it. The Moldavian SSR Gosnab [State Committee on Material and Technical Supplies] did not develop an optimal scheme of distributing railway bases and warehouses capable of receiving and unloading coal-laden railway cars. The material and technical fuel supply base is developing at an extremely slow pace. All this delays the turnaround of railway cars and reduces fuel quality.

The communal economy is not served with the proper efficiency everywhere. Deadlines for repairing apartment buildings and apartments, and central heating and hot-water supply in the Dondyushany, Drokiya, Orgeyev, Kamenskiy, Komrat, Kaushany and Chimishliya rayons are being dragged out.

Special consideration should be devoted to heat and water supply. All types of transport should also be prepared for winter use.

It is possible to assure reliable energy supply to customers in the upcoming fall-winter period only under the condition of a very strict regime of conservation of fuel, heat and electric energy, general observance of technological discipline, and timely and quality performance of all preliminary work at enterprises and in organizations. Soviet, trade-union and management organs, groups and national control stations should motivate the workers to fulfill and overfulfill tasks for conserving and eliminating unproductive fuel and energy losses, and should create in the collectives intolerance of negligence in their consumption.

Secretary of the Moldavian Communist Party Central Committee B. N. Savochko spoke at the conference.

Taking part in the conference's work were member of the Bureau of the Moldavian Communist Party Central Committee and Chairman of the Moldavian SSR National Control Committee P.V. Voronin, Deputy Chairman of the Moldavian SSR Soviet of Ministers and Chairman of the republic's Gosplan V. G. Kutyркиn, and business-manager of the Moldavian Soviet of Ministers V. I. Dobynda.

12421
CSO: 1822/56

GENERAL

HOUSING NEEDS FOR OIL WORKERS IN MANGYSHLAK

Alma-Ata KAZAKHSTANSKAYA PRAVDA in Russian 30 Oct 83 p 2

[Article by Special Correspondent G. Dil'dyayev: "A Home for the Oil Worker"]

[Text] Oil production operators and drillers, bore hole repairmen and petroleum transport personnel, geophysicists and tower erectors--tens of thousands of these most prevalent professions in Manglyshak are engaged in extracting liquid fuel from the earth. They work in oil fields located in the most varied corners of the kray, and live in the cities of Shevchenko and Novyy Uzen, in Zhetybay and Munaysha, and in the work settlements which have arisen in recent years on the Buzachi Peninsula. They are doing well as their above-plan production of raw materials attests. But how are their living conditions?

Cities, like people, have their own fortunes. Present day Shevchenko presents the appearance of a young, dandified intellectual, an engineer, looking out at the Caspian through the eyeglasses of shop windows. Novyy Uzen is a city in work clothes, and "capital" of the Manglyshak oil region. It stands in the very center of the bleak peninsula. Drilling towers and pumping jacks, pumping oil from innumerable wells can be seen on its outskirts.

These cities differ not only in their "social origin," but also in the circumstances of their birth. For Shevchenko they were happy ones; it was "well-born" by design. Leningrad architects of great experience were present at its cradle. The city was planned from the very outset, by a single client and contractor. Novyy Uzen was much less fortunate in this sense.

When the new Uzen oil field was discovered in 1961, the question arose of where the thousands of people who were arriving, pouring into collectives and beginning its exploitation were to live. Shevchenko was then the small settlement of Aktau, and was far from Uzen. Therefore it was necessary to build a city of their own for the oil workers. But where? Fifty kilometers from Uzen on the banks of the Caspian was the old fishing village of Fetisovo.

It was tempting to locate the new city there in order to exploit the favorable coastal climate. However, objections were raised to the advocates of this option. The road to the sea would cost a pretty penny, as would future transport. Therefore, it was necessary to build right at the site. These arguments turned out to be stronger.

Tasks concerning oil production and transport were solved more quickly; concerns about the city were put on the back burner. Along the way there were temporary variants (as everyone knows, nothing is more long-lasting). The drawing up of a general development plan was delayed, and the future Novyy Uzen was "attached" to the poorly arranged settlement which had grown up accidentally. This causes a mass of problems.

Despite many difficulties, the workers' city arose and spread out in the center of Mangyshlak. It was marked by architectural and city planning innovations. For example, the series of "ulitka" [snail] type residences developed by the Kazgiprograd designers was a success. These houses withstand well the winds and sun. The fourth mikrorayon of Novyy Uzen they built is notable for its modern appearance and is comfortable. A palace of culture for the oil workers, a beautiful Young Pioneer Palace, and other facilities finally opened after long years of construction adorn the city. To a person coming here for the first time Novyy Uzen is striking for its abundance of vegetation. The road to the sea was built after all, and there is a holiday area in Fetisovo.

In short, the fifty-year old city of the oil workers is getting better each year, and is finding its own personality. It holds a major place in the oblast's economy and is an important link in the Mangyshlak territorial production complex.

However, earlier errors cry out today. Those very "temporary decisions" have led, for example, to a muddle of city pipelines and water mains which is aggravated by ongoing corrosion. Tremendous resources have gone into endless repairs and changes in the heat supply plan. Truly heroic efforts were required to reduce the annual winter flow of citizens' complaints and provide a tolerable supply of water and heat to the apartments of the oil workers.

The foundations of many hurriedly built houses were not dug down to bedrock. This led to lamentable consequences; dozens of ruined houses in the city, which make up a significant part of the available housing. The amount of repair and renovation required has been great. A bureaucratic approach and regionalism have interfered with finding solutions to the many problems of Novyy Uzen. For example, debate about transferring the housing facilities to the sole control of Minnefteprom [USSR Ministry of the Petroleum Industry] and about improving line servicing has been long and without results.

For many years the Mangyshlakneftegazstroy petroleum construction trust was based in Novyy Uzen. This, frankly, created the city and supported its economy. Now the trust has been moved to Shevchenko, and the problems of repairing and maintaining the housing and public, cultural and domestic

facilities in Novyy Uzen have become still worse. Minnefteprom plans to establish a repair and construction trust within the system of the Mangyshlakneft' association. It should be located in Novyy Uzen.

From the very start of exploitation of the Zhetybay deposit, the question of how to settle the people working there has never been decided. Again hopes were placed on temporary variants, and a chain of villages each bearing the same name appeared. The oil workers took over housing left by the geological prospectors, but they, as is known, build only temporary structures and barracks.

"And we live in them," says B. Yel'bayeva, an operator in the Zhetybayneft' administration.

"I will not hide that at times it hurts me to the point of tears. I produce oil and gas, but at home I have to stoke my furnace. Frankly, what is most irksome is not knowing how the housing problem will be solved under our conditions."

The Zhetybayneft' administration is not fulfilling its fuel production plan, and hundreds of wells are standing idle. Hundreds of experienced operators have left the collective, and the main reason is the poor living conditions. The Mangyshlakneft' association is not building housing here, based on strict instructions from the ministry, which has decided to allot apartments in Shevchenko to the Zhetybay oil workers.

Last year they obtained 10 apartments in the oblast center, but there are 300 people waiting in line. Moreover, it is reasonable to ask whether there is any sense in moving everyone to Shevchenko. It is 60 km from there to Zhetybay, and it is not easy to make a round trip every day. Already by 5 pm the oil fields are empty; the people are hurrying to the buses. But oil production goes on 24 hours a day. If a well shut-in occurs or the oil production system is disrupted, it is necessary to wait until the next morning. Nevertheless, so far there is someone here to call upon to handle emergencies and place on evening and night shifts. So far...

It is necessary to determine precisely the future of the collective and decide which portion of it will live in Shevchenko and which in Zhetybay. To do this it is necessary on the one hand to design a plan for the reconstruction of the Zhetybay settlements and the organization of their public services and amenities, and to tear down the barracks, after having built in their stead houses for those Zhetybay residents who have established strong roots here (there are families who have even started a home of their own!). On the other hand, it is necessary to sharply increase the amount of housing construction for the workers of this administration located in Shevchenko.

In the mid-1970's oil gushers were struck on Buzachi Peninsula. Their whine drowned out the voices of those who had begun to talk about the "decline" of the Mangyshlak oil region. Decisions of the 26th CPSU Congress provided for the accelerated development of the new Buzachi oil deposits of Kalamkas

and Karazhanbas. A 300 km long road, oil pipeline and electric power line were laid to these locations, at the northwest extremity of Mangyshlak. Hundreds of wells are already in operation here. A new and growing oil production region has developed here on the Caspian seacoast. Now the annual yield of liquid fuel here will reach a million tons.

There is no end of work ahead. Industrial capacities will increase from year to year. There are plans to drill tens of thousands of producing and relief wells. A major water line will bring water here from the Volga. Construction of a major power station on the Buzachi Peninsula is planned. Experimental production efforts to introduce new thermal methods of oil extraction are underway at the Karazhanbas deposit. This work is very important, large-scale and promising.

Geologists are continuing exploratory drilling in the adjacent areas of the Caspian coastal region. They are confident that discoveries of new deposits await them in the near future. Geophysicists have also started talking about promising new deeper deposits.

In short, the very recently unpopulated bank of the Caspian is now heavily populated. The rotating-duty method of labor organization, which Minneftegazstroy and Minnefteprom use widely when developing new deposits discovered in remote, sparsely settled regions, has enabled the riches of the kray to be so quickly placed in the service of the national economy. Here in Buzachi the crews come on shift, work for 15 days, and turn things over to their relief. The Buzachi workers are registered in Shevchenko, Novyy Uzen', and many in Makhachkala, Groznyy, Baku and Krasnodar Kray. The rotating shift crews live in mobile field houses in the worker settlements located in Kalamkas and Karazhanbas.

"It will do, after all it's temporary," the oil workers replied to the question of how things were going here. However, they added that the mobile houses are cold in the winter and hot in the summer. Are the trips to and from work tiring? "They are tiring, of course, but this is also temporary, for a year or two, and then we will find other work." The section chiefs talked about how difficult it is under these circumstances to create a strong collective, about the high labor turnover and about the sub-standard discipline.

While it solves many problems, the rotating-duty method also creates many problems. For example, the doctor, news-stand minder, barber, film projectionist and recreation club manager do not commonly frequent the shift.

Soon, tens of thousands of people will be working on Buzachi Peninsula. Confirmed and expected hydrocarbon reserves have permitted specialists to say that working of these deposits of oil and gas will go on for several decades. This is a conservative estimate; optimists give other time periods. Let's be realistic: can and must so many people live and work here for more than a century under the rotating duty method? These shifts are an expense to which we can reconcile ourselves only at the outset. Moreover, they are not only expenses in the social sense, but in the final analysis economically as well.

Specialists in regional planning have a term--city forming factors. There are rather many of these very factors on Buzachi Peninsula, including prospects for development of the oil and gas production industry, permanent service lines linking it with the oblast center, a future power station, an airfield with a runway capable of handling heavy aircraft, water from the Volga, and beaches on the Caspian Coast.

At the request of the Mangyshlak Oblast ispolkom, the Kazgiprograd institute produced a settlement plan for oil workers on Buzachi Peninsula. Carrying out a complex analysis of the existing situation, the institute specialists determined the economic utility of building here a single, major, permanent and modern city-type settlement. In their opinion this will not only improve the way of life of the Buzachi residents, but will also significantly accelerate the development of the productive forces of the kray and create favorable pre-conditions for attracting population and other economic sectors here, most importantly those who would serve the needs of the petroleum industry. However, Minnefteprom intends to continue to exploit the Buzachi deposits using the rotating-duty method.

To build a city is not a simple matter. It must be well thought out. It is important, though, not to let the time for decision making slip by, and to consider the lessons of Novyy Uzen and Zhetybay.

9069

CSO: 1822/78

GENERAL

KAZAKHSTAN POWER PLANT CONSTRUCTION PROBLEMS, FUTURE NEEDS DISCUSSED

Alma-Ata KAZAKHSTANSKAYA PRAVDA in Russian 30 Oct 83 p 2

[Editorial: "Power Specialists' Urgent Tasks"]

[Text] Speaking at the June 1983 CPSU Central Committee plenum, Comrade Yu. V. Andropov stated: "The Food Program and Energy Program is a document of great long-term importance, a sort of GOELRO [State Commission for the Electrification of Russia--1920] under modern conditions." The importance of energy in the development of the entire economic system is well known. Thus the opening of a new high voltage 110 kilovolt electrical power line will ensure the intensive development of all agricultural sectors in the Beskaragayskiy Rayon, Semipalatinsk Oblast. On the eve of the 66th Anniversary of the Great October Revolution, the collective of the Kazelektroset'sstroy electrical construction trust turned over a 40 kilometer sector of the line early. The Semiyarskiy Sovkhoz was first to be connected to this line. Here a tremendous irrigated tract of 80,000 hectares is now under development, and the land reclamation personnel will be the main users of electrical power in this rayon. The construction of new sub-stations in the Karatal'skiy Rayon of Taldy-Kurgan Oblast, where work to put animal husbandry on an industrial basis has been well underway in recent years, will help sharply increase the level of mechanization of labor in these complexes.

Such examples indicate that definite experience has been acquired in the republic in finding a comprehensive solution to key economic problems. It is even more important that the Kazakhstan power industry be fully responsive to today's requirements. However, there are still many unsolved problems here.

The KaSSR Ministry of Energy and Electrification fulfilled its main economic indices for nine months of this year in volume of production implemented and in thermal power output. At the same time, the industry as a whole and the Ekibastuzenergo energy association did not meet their goals in such most important indices as overall volume of production, labor productivity and electric power output. The successful completion of the third quarter nevertheless did not eliminate the shortfalls of the first six months, especially those by the collectives of the Pavlodar energy node power station.

KAZAKHSTANSKAYA PRAVDA recently discussed the situation existing in the Pavlodarenergo power stations, and the fact that in recent years the republic's largest energy system has been in a critical situation. Indices have declined and stoppages and accidents have become more frequent. There are several objective and subjective reasons for this. The main reason is that Pavlodar's Irtysy-area energy industry has aged and requires fundamental reconstruction. To solve this problem, party and soviet organs must provide the most effective possible assistance and support, as was done during the capital repairs to a number of Yermakovskiy GRES [state regional electric power plant] units where competition was well organized and the use of progressive methods of labor organization brought tangible results. Party and soviet organs of Pavlodar Oblast must outline and accomplish specific steps to stabilize the work of Ekibastuzskiy GRES-1. As a consequence of the unsatisfactory assimilation of newly introduced equipment, the plan for developing electric power is not being fulfilled here systematically, and a high accident rate is permitted. It is necessary to seriously think about the reasons for the unstable work of the station and solve the problems of obtaining qualified operating and repair personnel, and consequently also those of constructing housing, schools and nurseries. This year the republic Ministry of Power and Electrification alone plans to build 78,700 square meters of housing in Ekibastuz. However, only 23,300 square meters have been completed during the past nine months.

The decisions of the November 1982 and June 1983 CPSU Central Committee plenums stressed that it is necessary to improve greatly the entire level of economic work and turn our entire huge economy into a reliably functioning mechanism. It is especially important to ensure an efficient rhythm in fuel and energy construction projects, and concentrate efforts on the quickest completion and start-up of those enterprises that can provide the greatest production growth. However, general contracting organizations of the republic Ministry of Power and Electrification permit significant lags in the area of capital construction. The Sredazelektroset'stroy power construction trust has not yet developed the construction of the Yuzhnokazakhstan GRES - Alma-Ata high voltage line. Construction on the Alma-Atinskiy and Tselinogradskiy TETs-2 [heat and electric power plants] by the Sredazenergostroy power construction trust is being carried out in an extremely unsatisfactory manner. Fulfillment of the water power development reconstruction plan at the Temirtau reservoir is stalled. This is a most important installation of the Kazakhstan Magnitka. Capital investments and construction and assembly efforts are not being utilized to the maximum at the installations being opened by the republic Ministry of Power and Electrification: expansion of the Pavlodar TETs-1; construction of a sub-station with an autotransformer in Novyy Uzen, Mangyshlak Oblast; and Petropavlovsk TETs-2. It is clear that it is practically impossible to solve the important tasks of energy without accelerating the tempo of capital construction and assembly. During the time remaining until year's end, it is necessary to make maximum efforts to rectify the existing situation.

It is necessary to devote particular attention to preparing power stations and the power supply network to work reliably during the winter. As a model

of cooperation between the Kustanayenergo collective, industrial enterprises, construction and assembly organizations, and scientific workers, one can take the example of the work accomplished ahead of time on strengthening the inter-system Sokol-Bsil high voltage line, which had suffered greatly from the raging elements last winter. Work valued at almost a million rubles was accomplished ahead of time and was of high quality. Energy consumers of Turgay, Kokchetav, Severo-Kazakhstan, Tselinograd and Karaganda oblasts will be supplied with reliable electric power.

It is necessary to speed up capital repairs, making use of the experience which has been acquired. Presently the republic Ministry of Power and Electrification system has practically completed all repairs to the electrical and thermal power networks. However, delays are being permitted in organizing repair of hot water heaters and turbo-units by the Ekibastuzenergo, Tselinogradenergo, Karagandaenergo and Gur'yevenergo energy administrations. A number of power units at the largest electric power stations have been down for an intolerably long period of time. Each power specialist and party and economic worker must recognize with complete responsibility that winter will be most harsh on unfinished work.

The collectives of the republic's energy system are working intensively to improve all technical and economic indices and strengthen labor and production discipline. Reconstruction and repair work carried out at electric power stations which use high-ash coal permits the hope that they will reach the level of power output envisioned by the five-year plan. The Ministry is taking steps to obtain, retain and improve the qualifications of cadres and is improving workers' economic education, individual training and exchange of advanced experience. Comprehensively solving difficult technological and production questions and educational, social and domestic problems, the republic's power specialists are filled with resolve to worthily complete the tasks of the third year of the five-year plan and the economic and social programs outlined by the 26th SPCU Congress and the 15th Congress of the Kazakhstan Communist Party. The appeals of the CPSU Central Committee in preparation for the 66th Anniversary of the Great October Socialist Revolution are also directed toward this end:

"Workers of the fuel and energy system! Raise the output of oil, gas and coal, and the production of electric power!"

9069

CSO: 1822/78

GENERAL

NERYUNGRI WORKERS COMPLAIN OF SHORTAGES

Moscow STROITEL'NAYA GAZETA in Russian 2 Sep 83 p 2

[Article by Special Correspondent V. Antonov (Second in a series) "Across An Obstacle Course: Letters from Neryungn."]

[Text] Inadequate production capacity is one of the reasons for lagging production in installations of the South Yakutsk TPK [Territorial Production Complex]. There is also a shortage of workers. Here is data concerning the main general contractor of USSR Minugleprom [Ministry of the Coal Industry]: the 1982 plan was only 66 percent fulfilled by its own efforts, while the number of workers was higher than the plan called for. The same situation exists in the subcontracting sections. What is the matter?

Here is Block "D," house numbers 1-5, which is under construction. Some figures can be seen near one of the houses.

"What do you think? Who are they?" G. Platonova, foreman of the plasterers and painters asks sarcastically.

Apparently these women are painting the foundation and are from her crew. But they truly look strange, whether from the many various items of clothing or from their frost-covered cotton work clothes (the street temperature was below -30° C although it was already late spring).

"Don't be shy. They are painters, not snowmen," Platonova says as if reading my thoughts. "Such clothing is best for a scarecrow, but we have work to do."

Nearly the only specialized clothing for the painters are summer 'KhB' [cotton overalls], even in the most severe conditions of the North, where work halts only when temperatures go below -50° C. True, quilted trousers and sweaters are issued, but they are like a knight's armor. Output declines markedly.

"Here in Neryungri woolen undergarments, aviator boots, caps and fur mittens are greatly needed so that it will be warm and comfortable to work," the women say, interrupting each other.

"You see, there is a lot of outside work: we unload vehicles and finish the foundations, basement rooms, external window frames, entrances, tambours and attics. Many areas are in the open air: heat stations, transformers and distribution sub-stations, pipes to be painted..."

"Mostly middle aged women are working here. Young women don't come to work in the crew?"

Look, what young woman would want to crawl into this cotton sack? The boys wouldn't look at her."

And again well-worn truths are repeated. When will the sewing shops stop cranking out size 54 coveralls? The workers read with envy that in the Ukraine stores for specialized clothing have opened.

"Painters, especially in the far north, need painting and plastering stations, preferably electrically heated. Is there such a thing in Neryungri?"

"Are you kidding," the finish workers say in amazement. "Even if such things are manufactured they are in such small quantity that they don't get to us. We don't even have enough electric heaters and are using liquid fuel motors."

They drag me to the nearest apartment to show me what they meant by a liquid fuel motor. It is a depressing sight. The fuel does not burn completely and smoke and fumes leave a mark on the clean witewash. It is not by chance that the contractor quite frequently requires that already completed work be done over.

Assemblers also work on the construction of the house. They have the same troubles with the specialized clothing as do the finishers.

"Here, look," Foreman N. Sorokin on the fifth floor shows me. "The sweaters are not sized and they restrict movement. People walk like on a knife blade, facing from side to side. Warm, beaver Lamb clothing, preferably heated, is required in our conditions."

"The 'Pingvin' [penguin] type costume?"

"No, it is not suitable for an assembler. It is too heavy; the heating elements alone weigh up to 7 kg."

"On a knife blade" is not hyperbole. I became convinced of this with my own eyes when I went up to the fifth floor. The felt boots slip like skis (they are worn by assemblers, working high in the air!).

"We need light, gripping overshoes or mountaineer type boots, as well as wool comforter caps and fur socks. The latter do exist, but for some reason we are not authorized them," the assemblers state.

They turn this correspondent over to the welders. On the way they invite me to solve a riddle: If I want to work in the mask (this is mandatory), how can I then put on the helmet (also mandatory)." I try to solve this problem conscientiously and evoke only laughter.

"Don't try, it's useless. We've checked it out. What is needed is a combination mask-helmet with a lift-up glass piece. They say that somewhere they are made, but there have never been any in our UMTS [Administration of Materials and Equipment Supply]."

"But why don't you even wear the helmet when you are not welding?" In reply they hand me a helmet which they have gotten from somewhere and invite me to put it on over my cap. I return it immediately; even without trying it on it is clear that it won't fit.

"Have no doubt, this is the largest Trud [Labor] or Shakhter [Miner] helmet. They are for summer use in southern areas. In the north we need motorcycle type helmets or helmets with rigid ribbing." The welders came across as jovial, but their jokes depressed me. They gave me a standard electrode holder and invited me to imitate making a simple weld. Naturally I wasn't able to. I could not even get near the metal due to the unwieldiness of the electrode holder, not to mention its excessive weight. How do they get around this? Very simple. They make their own holder, thus committing a gross violation of safety procedures.

The "obstacle course" did not end with this. One of the welders took off his gloves and invited me to hold the electrodes. Again it was awkward; the instrument fell out of my hands. The gloves were made of coarse tarpaulin which had absorbed sweat and stiffened during cold weather. But, you see, it is necessary not simply to hold the electrode, but to feel the holder and the electrical conductor in one's hand. One cannot get by without light, soft and absolutely waterproof gloves.

"Perhaps you would like to try on our imitation leather high-boots or our military boots? By the way, they serve as an excellent conductor through the nails in their soles," the welders say with continuing animation."

No, the builders of the South Yakutsk TPK were not complaining. They were graphically explaining to me one of the reasons for the decline in the productivity of their work.

9069
CSO: 1822/78

GENERAL

PROBLEMS FACING PAVLODAR-IRTYSH AREA POWER PLANT BUILDERS OUTLINED

Alma-Ata KAZAKHSTANSKAYA PRAVDA in Russian 14 Oct 83 p 2

[Article by Correspondent V. Stupak: "To Find Reserves"]

[Text] Perhaps never before have the duties of the Pavlodarenergo collective been as intense as today. There is a reason for this. In recent years Kazakhstan's largest energy system found itself in a critical situation. First there was the inexorable worsening of indices, then the increasingly frequent stoppages and accidents, and as a result the loss of reliability, the main index of a power system.

In general a natural thing had happened; the Irtysh-area power system had aged. The high ash content and toughness of Ekibastuz coal to a large extent was the result of the premature deterioration. For example, the pipe walls through which coal dust passes into the furnace narrow in size by six millimeters per year.

The serious conditions demand total re-building of the hardware, right down to a complete exchange of the materials from which they were manufactured, and in some places even a complete change in the technology for processing and delivery of coal. Included were plants within the territory from Omsk to Ust-Kamenogorsk and from Barnaul to Tselinograd, but especially in Pavlodar.

As is well known, a power system without reserve capacity can fail at any moment. That is why today the list of work that the 10,000 man collective has undertaken to fulfill is so great. Their main objective is stipulated in the first point of their duties: "To ensure a reliable and uninterrupted supply of power and heat to the consumers."

By the start of this year, in what shape was the Yermakov GRES [State Regional Electrical Power Plant], the largest plant in the system?

"To straighten things out we created a special repair staff back in December when preparations were going on," states K. Shabanbayev, GRES party committee secretary. Every week the staff examined problems of seeking out and acquiring spare parts and materials. It coordinated all repair operations. This permitted us to approach our work in an organized manner, and to carry it out according to a precise schedule. Competition for the best repair crew, which we set up for a season of overhaul and medium repairs, was helpful. On Unit No. 4,

the collectives of L. Anastasov and V. Kondrat'yev from the central repair shop, and A. Barbakar' and A. Tkachenko from the Sevkazenergogorremont repair enterprise were exceptional. I would especially like to note the contribution of Vladimir Uchanev, a most expert master welder and talented inventor.

Now Energy Unit No. 4 is successfully handling its load, which is the best attestation to the repairmen. The Yermakov workers also set about their over-all efforts to overhaul Unit No. 7 in an organized manner. Here it is true that there were not enough workers, a great deal of unanticipated work emerged, and the lack of spare parts slowed matters down. But the method of crew organization and work incentives, which is increasingly taking root at the station, helped them to deal with all the work.

At the same time, reconstruction is not stopping at the GRES. Now, for example, three units have already replaced screw-type slag conveyors with a reliable electric drive assembly, and for delivery of fine coal a more durable and long-lasting screw-type conveyor has been installed instead of the drag conveyor. Similar efforts have been made with many other assemblies.

"Most work on which we undertook commitments has been fulfilled," states K. Shabanbayev. "Now I can say with confidence that on 1 November, as written in the commitments, the power system's largest GRES will be ready to operate under winter conditions."

However, not all of the system's power stations are entering winter with such confidence. Until the very last moment the power engineers believed that the Pavlodar TETs-1 would have to provide heat, steam and electricity to all of the city's industrial areas, and to begin winter without a fuel shortage. It had to be "covered" by Heat Plant No. 7. The socialist commitments taken by the Pavlodarenergo collective provided for putting the plant into operation in October and reducing the repair period by two months. Work was carried out all summer at an accelerated tempo, and it seemed that nothing threatens the promised start. Consequently, the living quarters and greenhouses will not experience a shortage of heat as they did last winter.

Meanwhile, last month the Sredazenergomontazh administration headed by G. Zherebtsov suddenly "started skidding" in place. The collective became tied up in a number of minor instances of unfinished work and the start was postponed until the end of November. This means that the opening date may be changed again in the future.

The unexpectedly protracted repairs to Boiler No. 5 are worsening the situation at TETs-1. It was stopped on 7 September, and was to be restarted after 60 days, that is on 7 November. But inspection of the unit and its mechanisms revealed such great wear and tear that to recondition it in two months turned out to be unrealistic. This is all the more true because there are no spare parts and most components and assemblies have to be reconditioned on site.

"It is proving especially difficult to repair mechanisms which operate under extra difficult conditions, such as grinders and dredging pumps," states A. Safarbakov, chief engineer of Pavlodarenergo. "It is taking away an entire

army of people, and just the same cannot save the situation. It was proposed that a special factory having a large foundry would do this; however, time goes by and construction of the factory in Ekibastuz has not begun. Minenergo does not even have such enterprises in neighboring regions. Therefore, we place all our hopes solely on local industrial enterprises of other departments. In particular, the tractor and aluminum factories are of great help.

The steel "beater" in the coal grinder should last 800 hours, but after 80-100 hours particles from Ekibastuz hard coal reduce a half-pood [8.19 kg] flange to a pitiful stump half the size of one's palm. Naturally the grinder must be stopped and a "beater" fused on. This is difficult work which eats up time.

Last year we asked the tractor builders to cast us a "beater" from manganese steel. This "beater" actually did hold out longer than usual, but nevertheless we had to reject the idea; it was not what was needed. However, the cooperation we had entered into with the tractor builders did give hope to the power engineers. In fact, the metallurgists from the tractor factory did not stop looking. They welded a super-hard blade from special components which had been suggested by scientists from Sverdlovsk. It is enclosed in a casting frame cast together with the "beater," thus becoming similar to the reinforcing stem in a pencil. It would seem that the problem of the "beater" had been solved, but it turned out not to be. Each year 150,000 are needed. The tractor builders are now hitting themselves: "Why did we become involved in this business? Our job is to build tractors, not beaters for coal."

They are right, of course, from their own departmental position. But what if we look at things from a national point of view? For whom more than industry does the energy system operate in the first place? And what about the territorial production complex. That is not an abstract concept. The foundations of tomorrow's economic relationships are built on cooperation among departments. Through supporting each other, the industrial giants will become stronger much more quickly. It goes without saying that the acuteness of the problems of building an energy repair factory in Ekibastuz is not removed by this. Without such a factory it is each day more difficult and expensive to get by. But the urgent task of the day demands mutual assistance. Right now.

It seems to me that the party committee, trade union committee and directorship of the Pavlodar Tractor Factory would be displaying a modern approach to their work if among the socialist commitments made by the collective for next year they would include, for example: "We consider it necessary to make a significant contribution to the implementation of the USSR Energy Program. The metallurgists of the association will undertake to manufacture and deliver on time 150,000 "beaters" for the oblast electric power stations." The power workers would not stay in their debt.

9069
CSO: 1822/78

GENERAL

LACK OF AIRPORT OFFICE SPACE, MANAGEMENT PROBLEMS IN KATEK REVIEWED

Moscow VOZDUSHNYY TRANSPORT in Russian 6, 8, 10 Sep 83

[Article in three parts by E. Maksimovskiy, special KATEK correspondent:
"The Changing Face of Enormous Territories"]

[6 Sep 83 p 3]

[Text] I. "Why build a midget airport in Sharypovo? Won't you have to begin all over again in about 10 years?"

Starovатов was surprised by my questions: "Surely someone told you...." Then he decisively got up from the table, went into the next room, shuffled invisible papers and came back holding a rectangle of thick Whatman's paper. "Here is how our terminal building will be."

Depicted in water colors was the facade of a neither large nor small building, which, in the opinion of my interlocutor, the first secretary of the Sharypovo party gorkom, Gennadiy Fedorovich Starovатов, will meet the passenger flow of 1990, when the population will have leveled off and will no longer be growing at the current pace. The ceiling is 250,000.

"Kedrovsk" was written above the picture with a pen. I tried to recall just where this town was in Siberia or in what other part of the country. Maybe it didn't exist. Was it all the same? Gennadiy Fedorovich smiled and answered: "We're trying to find a name for the new town of Sharypovo. For example, at first everyone liked the idea of calling it Belozersk. We looked in the geographical dictionary and there were lots of Belozersks."

He explained the necessity for changing the name. "The ancient village of Sharypovo with its few natives is dissolving in the flow of new settlers and in blocks of multi-storey dwellings. Named at one time after the first settler, who was from Arkhangelogorodchina, Sharypovo is gradually being transformed into the main city of the Kansm-Achinsk Fuel and Power Engineering Complex (KATEK). Simultaneously, many collectives of industrial and transport enterprises are being formed. We are trying to find an image of the KATEK capital that will attract people."

The aviation people also realized this. Above the temporary but very durably built terminal building, which still smelled of paint and lacked furniture,

they erected huge orange letters: "KATEK Airport," thus confirming in the passengers' consciousness the special significance of the town in the development of the nation's largest coal-drilling basin.

The gorkom secretary spoke enthusiastically, with great faith in the practicality of the plans for creating the powerful fuel and power-engineering complex, about which Academician A. Trofimuk said literally that "the given problem is more significant than the problem of harnessing nuclear power and widely distributing atomic power-engineering in our country, because the power from KATEK will for a long time be cheaper than all of its other aspects."

II. Listening to Starovarov, I especially regretted that the Deputy Commander of the Aviation Enterprise, Gennadiy Panov, had flown out on a business trip from Sharypovo to Achinsk. We had managed to visit together only the airport builders. Later, after the long journeys on a Moskvich along the western wing of KATEK, from town to town and airport to airport, I will tell Panov what I heard in the gorkom secretary's office and will make note how sincerely interested he will be when he asks questions, refines, and expresses his views. Personally I have already become accustomed to this--airmen working in areas of new economic development with the rarest exception are energetic, involved and motivated people. I remember what I heard on the Baykal-Amur line: "We are building BAM, BAM is building us." Surely the same may be said of KATEK.

The scale of unparalleled achievements was emphasized at the June Plenum of the CPSU Central Committee: "We are realizing the largest comprehensive socio-economic programs, including the Food and Power-Engineering Programs, we are intensifying production, accelerating scientific and technical progress and changing the face of enormous regions...."

So what is KATEK and how can one discuss its airport development, when the Transsib already runs here and another railway is being laid almost along the meridian from Lesosibirsk to Uzhur and further to Abakan? Local highways will be modernized rather quickly. Moreover, the Yenisey will divide KATEK into equal parts. What can an airplane do here?

It is rare for one to find such an abundance of transport links in a new rayon. Still, they told me in the USSR Gosplan, the regional party committee, and the organizations of Sharypovo, Nazarovo and Achinsk that KATEK needs increased aviation support. Of course, this opinion is nothing new for the management of the Krasnoyarsk civil aviation administration. Its service has been systematically extending KATEK's aviation. Airport collectives, although still small, are gradually "growing."

In recent years, airstrips were built in this zone. Obviously, some of these must be lengthened to land heavy planes. At the request of local organizations, regular flights were scheduled from Sharypovo to Bratsk and duty flights to Ust-Ilimsk. Airport manager V. Myachin thinks that, in the future, Sharypovo will have to have air links with Novosibirsk, Kemerovo and Tomsk. Starovarov holds the same opinion.

His colleague, A. Merezchnikov, first secretary of the Nazarovo CPSU gorkom, thinks that there should be flights from this town to Novosibirsk, Kemerovo, Abakan and also Moscow. According to his calculations, 30-40 people fly daily from Nazarovo to the capital via Krasnoyarsk. Where is this multitude of passengers coming from? These are mainly "different types" of specialists.

"Nazarovo--Base of KATEK!" This information, composed with 28-inch letters, may be read when one enters the town. Merezchnikov comments on the sign:

"We are expanding and building several plants for non-metallic materials, metal structures, precast reinforced concrete and panel house-building. Power is provided by the second largest fuel station (after the Urals), the Nazarovo GRES [State Rayon Electric Power Plant]. They still call it the KATEK's first-born. As to the question of its expansion, there will be two more 800,000-kw units. This is why there are many passengers from the center of the nation--scientists, designers, power engineers and coal miners. These are all business people, and the days they lose while waiting for available seats, flights, etc., to a considerable extent delay the progress of construction, design coordination and production of technical and economic foundations. At least we should now increase the frequency of flights to Krasnoyarsk. Usually after 5 pm there are no more tickets."

These problems may be projected to the airstrip of Achinsk, which gave its name to KATEK. The assistant manager of Krasnoyarsk Civil Aviation Administration, G. Khokhlov, related that it is planned in 1984 to open air traffic between Achinsk and Moscow: three flights a week from 25 May to 14 October on Il-18 aircraft. This may be likely in 1985 with Tu-154 aircraft.

III. Analysis of the economic development of KATEK's western wing leads to the conclusion that here, as in other regions of new development, air transport is called upon to play the role of catalyst of both economic and social processes. This is in spite of the density of railways and highways. The solution is quite simple: the western wing is becoming more and more detached from the nurturing organizations of the regional center--many of its problems are solved outside the bounds of Krasnoyarsk.

Obviously, more and more zones will become autonomous until the designer and builder will be the chief figures here. The facts lead to the conclusion that the representatives of the most popular professions in Siberia will remain in this rank until the end of the century. KATEK is much more than a coal field. It is due to be one of the leading fuel and power-engineering bases in the nation. And not simply as a gigantic stakehold. The construction scale and depth of scientific and technical exploration are such that one can boldly speak of the future KATEK as of the backbone, as a minimum of half of Siberia's economy.

[8 Sep 83 p 3]

[Text] The time has come to answer the question "What is KATEK?" We turned with this request to Academician Abel Gezevich Aganbegyan, director of the

Institute of Economics and Organization of Industrial Production of the Siberian division of the USSR Academy of Sciences. He is well known to readers of "Vozdushnyy Transport."

Here is what he said.

The basin occupies an area of about 60,000 sq km, extending latitudinally almost 800 km along the Transsib. The total geological reserves of 24 brown-coal fields, calculated to a depth of 600 m, make up 600 billion tons. For comparison, in 1982 3.8 billion tons of coal (in conversion to enriched coal) was mined worldwide, including 647 million tons in the USSR.

The Nazarovo and Irsha-Borodino coal cuts now already yield more coal than the Moscow-area or Pechora basins. In the next 15-20 years, recovery will be increased to 300-350 million tons annually. The worker's labor productivity at KATEK is almost 10 times higher than that of the average union and 1.5 times higher than the average for USSR cuts. For one miner in the USSR, an average of 75.3 tons per month must be produced, 450 tons at the open works and 725 tons in the Krasnoyarsk area! Even the poorest coals are considered.

Coal workers plan to collect 110-115 million tons in the first stages of the basin's development, which is generally unprecedented in the history of this sector of the mining industry. The Berezovskiy cut, being built not far from Sharypovo, has no rivals in the world to its 55 million-ton design capacity!

I saw mounds of raised earth on the spot of the future cut--gray, clayey earth, and not far from the surface, an open, barely brown coal mass. A real treasure!

At KATEK it is planned to establish several GRES, each with a 6.4 million-kw capacity and each equal in power to the Sayano-Shushenskiy hydroelectric plant, calculated to maximum available water, and equal to it and the Krasnoyarsk hydroelectric plant together in electric power production.

It is estimated that each GRES will pay for itself in 5 years. But this will be possible if the zone's economic development will keep pace with its social, agrarian and transport development.

IV. Judging by all this, KATEK promises in time to become equal to the Western Siberian oil and gas complex in coal production. By the end of the century, it will equal, then perhaps outstrip the Tyumen area in both straight power production and production of chemical raw materials: under high temperature and pressure coal is converted to liquid and gas. The worldwide power-engineering crisis makes it necessary to seek full-value substitutes for liquid and gaseous hydrocarbons. Now these essentially may be only solid fuel and nuclear power engineering, which is still only on the ascent.

This is why there are no headlines in the world press announcing a coal renaissance, the return of coal, etc.

How can one not recall here Blok's verses:

Black coal--
 underground messiah,
black coal--
 both tsar and bridegroom,
but the sound of your petrous songs,
 bride Russia, is not frightening!

One need not travel to KATEK to be convinced of the scale of operations. A plant for heavy excavators, whose products will be sent almost entirely to KATEK, is being built near Krasnoyarsk. Its basic funds will almost equal those of the plant of plants, Uralmash. This alone already says alot.

And so it turned out that during meetings with the airmen of Sharypovo, Nazarovo and Achinsk, with port workers and aviation chemists, the conversation arrived at how better to organize the aviation facilities to the coal giant.

V. But here we must come down from the clouds to the earth and speak about the problems which can be solved freely at the locations. They appear quite simple and routine, and how familiar they are to the one who works at airports being reconstructed in the same zone as BAM-Ust-Kut, Tynda and Chulman. There are twin problems. Contractors and subcontractors compete for the most profitable work volumes and topple the percentage by their efforts. Then the workers take them to task, and then the state commissions, in order to report sooner, swear by all the construction gods that they are eliminating faulty work. But commissions, as it often happens, treat defective work as "out of sight, out of mind."

Vladimir Myachin has been serving as the manager of Sharypovo airport for several months. He was an excellent pilot--a fact proved by his Red Banner of Labor medal. However, on land there are other rules of "the game." He probably received the first indication of this when one smart local organization bestowed favor on him with nearly 400 chairs, not even interested in whether or not Myachin needed them. Of course, his agile partners made their profit--they presented him with a bill, as usual. Vladimir Konstantinovich showed me these chairs--impractical, not suitable for passengers and not "durable." Such seats fall to pieces faster than the cheap, thin upholstery on them can wear out.

Another manager would not have left unpunished the participants of this miserable story. Myachin was too restrained, and it would seem, unnecessarily so--the construction site would have had less schemers, about whom the first secretary of the party gorkom tersely and stiffly told me. However, I in no way intend to criticize Myachin: management experience comes with time. And for an honest, capable man, as the former pilot proved

himself at the Achinsk aviation enterprise, such lessons are useful--for surely it is easier to learn to fly than to learn to manage.

Take even the regular contacts of the workers of Sharypovo airport with the chief engineer of the "KATEKenergopromstroy" [KATEK Power-Engineering Industrial Construction] Trust, S. Mashykov. We, Gennadiy Panov, deputy commander of the Achinsk aviation enterprise, and I, would have wanted least of all to classify him behind his back as one of the "promisers." During the day we couldn't find him in the town of Sharypovo, although it is still possible to travel quickly around the small town by cart transport. And the mass of constructional defects was something to talk about. Life often proves that the elusive manager is, as a rule, an unskillful manager.

However, the trust manager, A. Utkin, was quickly located. We met in his office, not wasting a moment. And the conversation was, as it seemed to us, lucid and business-like. It turned out that everything could be done quickly without need to push. Arnold Ananyevich did not start pleading the lack of staff, vehicles or machinery, although, as at any construction site, these were lacking. Most often, those managers seeking larger and more profitable volumes put the blame on this. And only some 15,000 rubles of work still remains at the airport. Utkin gave his word that everything would be done in July.

July went by and soon we would know if his word was a signal to complete the work.

Then it will be time for the second stage--the terminal building (the same, above the picture of which is written "Kedrovsk"), garage, building for the transmitting center and other facilities. I heard from one of the responsible builders that the small station will be no larger than the present temporary building, and that's why I began asking Starovatov why he doesn't look at KATEK the potential.

Neither the first nor the second stage allot space for the airline booking office. On the spot where a broad and beautiful street will cross in several years stands a trailer and open barracks, some 20 feet in length, which are shared by the dispatching office of the auto transport enterprise, an amateur brass band which came here for "rehearsal," and the air booking office, at whose rickety doors people appear long before it opens and stand for hours. The so-called booking-office, in fact simply a lobby, occupies an area of approximately 4 sq m. One can imagine what a crush there is here when a seasonal storm cloud breaks over Sharypovo.

Now, a second cashier is being looked for--clearly, one cannot manage: the hundreds of people at the window have lost a lot of working man-days for nothing. The only question is how will the Sharypovo airmen be able to manage the second position. The first cashier's operating schedule is such that, whether they like it or not, future passengers are required to ask for leave from construction sites and enterprises "to get a ticket," or even simply leave the work place. "Otherwise they won't get a ticket," G. Dolgova,

a worker at the KATEKenergopromstroy, told me. It would seem that the second cashier should handle Saturdays, Sundays and work day evenings.

However, the appearance of a second cashier does not eliminate the space problem in the slightest. Here the ispolkom of the municipal Soviet of People's Deputies should have a word. However, while meeting with one of its authoritative workers, I somehow failed to notice a palpable interest in the problem of MVL [maximal pulmonary ventilation]: a relapse toward outdated ideas about the nature of organizing life at the new construction site surfaced. As is known, the miser pays double--of the 18 men standing in line at the booking office, 16 came from work places. And there is an acute shortage of labor resources in the town. According to A. Potekhin, member of the VLKSM [All-Union Lenin Young Communist League] Central Committee and fitter at the KATEKenergopromstroy, in one of the association's trusts, only three workers remained.

The words of Comrade Yu. V. Andropov that we must first of all put in order what we have, deeply impressed the Sharypovo airmen. The problems of developing the capital of KATEK and the flight industrial zone may be solved only by means of mutual communication and cooperation of all spheres of public life and production.

[10 Sep 83 p 3]

[Text] The hotels in the town of Nazarovo are slowing driving the air booking office from the foyer. To the right of the "booths" is the entrance to a restaurant, to the left is an administrator's post, straight ahead is a flight of stairs and here is a noisy crowd. Naturally, this neighborhood does not suit the "fathers" of the municipal communal economy. This question is not new for the first secretary of the CPSU gorkom, A. Merezhnikov, but, apparently, extra efforts are required on the part of the workers of the nearby airport in order for the municipal authorities to make the transition from grasping the problem to solving it.

"They promised us that in several years space would be allotted for the air booking office," said the manager of Nazarovo airport, Vyacheslav Sherstobitov.

It's a long time to wait! Indeed, Nazarovo, in contrast to Sharypovo, which is only getting on its feet, is a stable, orderly town at all levels. In the gorkom they persistently talk and argue about the necessity and exclusive importance of introducing new flights, but, in the process, why do they lose sight of the fact that a flight begins with the purchase of a ticket, and those Moscow and Novosibirsk specialists, whose time A. Merezhnikov is concerned about saving, are forced to stand in line 1, 2 or even more hours.

And the troubles of the local air passenger are not limited to this. Our conversation turned to the tiny booth on the edge of the new VPP [runway], which cuts through the arable land of the "Krasnopolyanskiy" sovkhov. The alienated land will no longer yield grain nor root-crops. But it should

serve other purposes, such as saving the working time of thousands and thousands and thousands of KATEK workers. The booth, where one could set three chairs at most, is Nazarovo airport. Passengers are not allowed here--it's for the technical service.

But a fully modern terminal building has appeared on another wing of the runway. Brigades directing the construction of Nazarovo GRES work in it, and Sherstobitov praises them: the young plasters are not fooling around and are working with enthusiasm.

KATEK's aviation development, and it's impossible not to agree with this, includes not only passenger transport. Crews of the Achinsk enterprise work on aerial weeding at many farms of the western wing. The work volumes here, of course, are not the same as in Northern Kazakhstan; the figures are not in the hundreds but tens of thousands of hectares. But the problems are the same, if on a smaller scale. But let us not forget that Eastern Siberia today brings in the majority of food products, which means that the price of each local hectare is increasing, just as each departure of an agricultural aircraft.

This was explained to me by the assistant manager of the regional agricultural directorate, Yu. Bykovskiy, rector of Krasnoyarsk Agricultural Institute, V. Zolotukhin, and the deputy commander of the flight subdivision, A. Melnik, whom I met on the fields of the "Nazarovo" sovkhov.

Arkadiy Filimonovich Veprev, who has been managing the sovkhov for 2 decades, achieved unheard results for Siberia. The economy is the only one in all of Siberia that in 20 years did not once ruin the plan to sell grain to the state. Last year the crop capacity at the sovkhov reached 36 metric centners from each hectare, and this was not on irrigated, but unirrigated lands! This fall also promises a good crop.

You talk with Veprev and look at his fields and the agrarian prospects of Siberia appear otherwise--fruitful, high-yielding and capable of feeding itself and sharing with the non-agricultural rayons of the region.

The director is worried by mutations and deformations of the ears, which are caused, in his opinion, by the "imperfection" of herbicides and delay in their application. This very experienced director also sees other problems in aerial chemical work. Here in Veprev's office I remembered a candid conversation with the manager of the department of PANKh [not further identified] KRUGA [Krasnoyarsk Civil Aviation Administration], L. Nepomnyashchiy, who frankly announced in the presence of several administrative workers that there were no problems at all with agricultural aviation in the KATEK zone and that AKhR [aerial chemical work] generally has no relation to the development of coal fields.

Obviously, Leonid Alekseyevich has not thought about the fact that the delivery of foodstuffs to the rapidly growing economic rayon contributes directly to its development. If he would only glance occasionally at the

fields adjacent to the huge cuts, or talk with the same Veprev or the aircraft commander, V. Gerasimov, second pilot, S. Fedkin or air technician, V. Popov, who have been in aerial chemical work at the Nazarovo sovkhos, perhaps then Leonid Alekseyevich would realize the true significance of aerial chemical operations for KATEK's development. Here he could learn not only about definite complications in organizing the work and recreation of the crews, providing them with heat, etc. (Veprevs are not everywhere). Progressive methods of aerial chemical work developed in Northern Kazakhstan, in Kubachi and other agricultural rayons could be used even here with limited correction, saving flight time, raising flight efficiency and saving fuel.

What a contrast the attitude of Veprev and V. Gerasimov's crew toward aerial chemical work proved to be! Unfortunately, they learned the details of organization and economics of aerial chemical work in the Western Siberian, Kazakhstan, Privolzhsk, and Moldavian civil aviation administrations from a journalist, not a PANKh worker.

Whether an accidental coincidence or the reflection of unfamiliar and exceptionally powerful geological processes in the earth's history, the Kemerovo coals lie exactly toward the 56th northern latitude from east to west, as do the nation's largest hydroelectric power plants. This parallel traverses KATEK and the entire BAM zone. Having been here, it doesn't take much imagination to picture the nation's economic resource--not even at the beginning, but in the middle of the 21st century.

By changing the face of enormous regions, the Soviet people will lead the nation to new heights of blossoming.

12421
CSO: 1822/41

END