

19981015 073

Automated Surface Observing System

ASOS

User's Guide

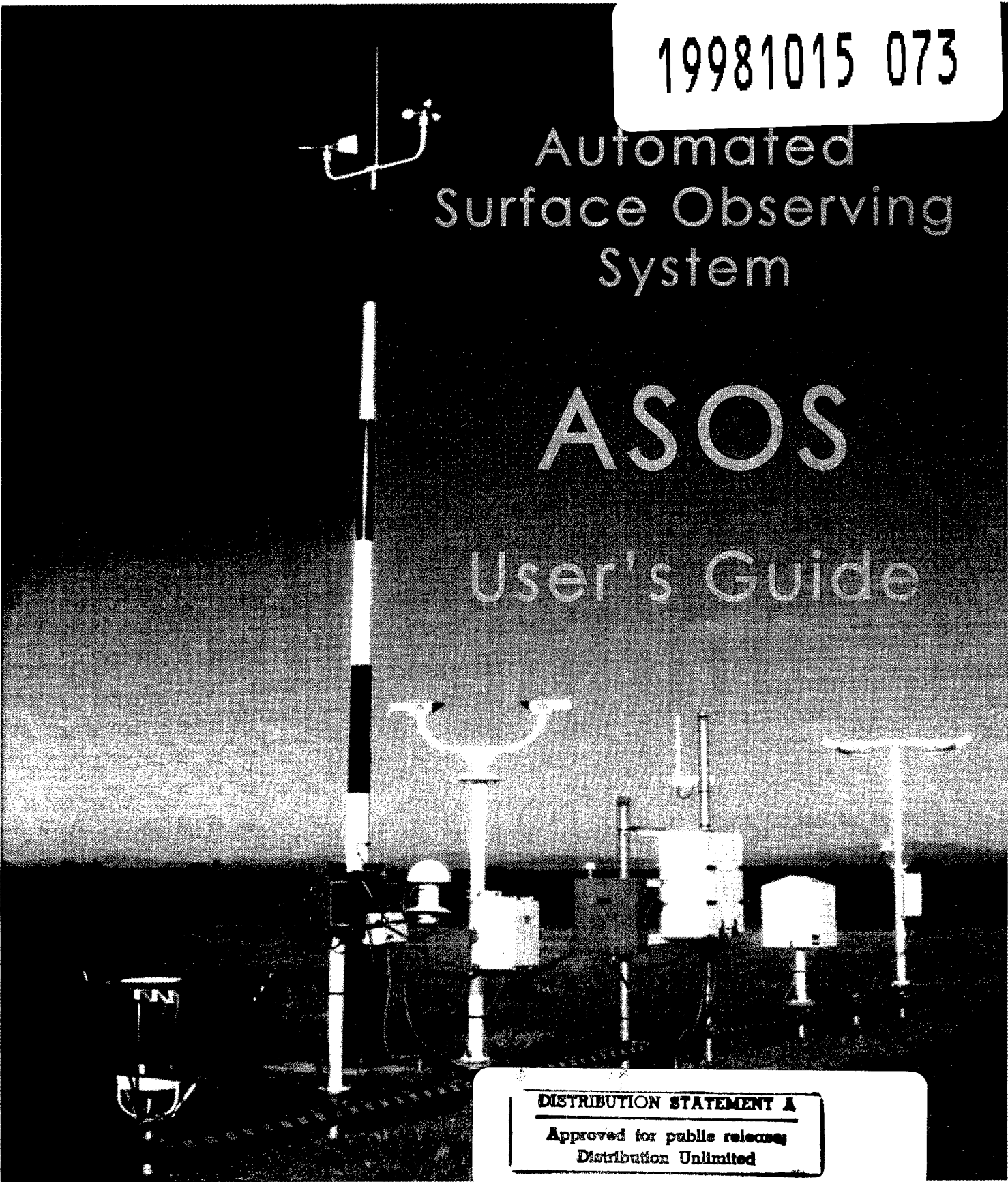

DISTRIBUTION STATEMENT A
Approved for public release;
Distribution Unlimited



March 1998

Automated Surface Observing System

ASOS

User's Guide



March 1998

Foreword

The 1990s have witnessed a carefully planned and executed modernization of the nation's weather services. The Automated Surface Observing System (ASOS) is the first system to be operationally deployed as part of this modernization. ASOS is therefore in the forefront of system deployments and associated service improvements that will require most of this decade to complete. In this sense, ASOS is the harbinger of 21st century weather services.

In the end state, ASOS will be operational at about 1,000 airports across the United States. This system is the primary surface weather observing system in the United States, which supports the essential aviation observation programs of the National Weather Service (NWS), the Federal Aviation Administration (FAA), and the Department of Defense (DOD).

The implementation of ASOS brings with it many opportunities and challenges. The opportunities include the unprecedented availability of timely, continuous and objective observations from many more locations. The challenges generally relate to institutional learning needed to fully understand and adjust operations to take the greatest advantage of this new technological resource. The potential applications of the ASOS data go beyond that of providing basic weather information for aviation and forecasting; ASOS also will provide enhanced support to vital national programs such as public safety, hydrology, climatology, agriculture, and environmental protection, just to name a few. The *ASOS User's Guide* is intended as a basic reference and introduction to ASOS for a broad range of users.

As of this writing (March 1998), there are about 500 commissioned ASOS's nationwide. An additional 500 are coming on-line in the next few years. This deployment fulfills the commitment the Government made over a decade ago to provide the nation a highly cost-effective, capable and reliable automated weather observing system for safe, efficient aviation operations and other applications. This achievement is made possible by the dedicated efforts of many people throughout the government and private industry working together as a team to conceive, plan, develop, test and evaluate, implement, commission, monitor, maintain and operate the system.

This *ASOS User's Guide* is gratefully dedicated to all who have worked so hard to make ASOS a reality. Special thanks are extended to Dr. Jim Bradley for mentoring this program from the very beginning. Finally I wish to thank Dave Mannarano for coordinating the writing and production of this *ASOS User's Guide*.



Vickie L. Nadolski
ASOS Program Manager

Executive Summary

The *ASOS User's Guide* provides a fundamental description and explanation of ASOS and its impact upon users of the Aviation Routine Weather Report (METAR) and other ASOS data. This guide is therefore designed to speak to a variety of interests inside and outside the federal meteorological community. The guide is written for those with more than a rudimentary understanding of the manual surface observation program.

Using the manual observation as context, the *ASOS User's Guide* describes the basic ASOS functions of data ingest, data processing and data distribution. Descriptions are provided, element by element, of the sensors and algorithms that ASOS employs. The guide also discusses the unique strengths and limitations of each ASOS data element.

Among the basic strengths of the ASOS observation is its capability to measure critical aviation weather parameters, such as sky condition and visibility, at specific locations where they are needed most—the touchdown zone(s). ASOS data are updated once each minute and transmitted directly to forecasters, air traffic controllers and pilots. ASOS is capable of performing all the basic observing functions and operating in either attended or unattended mode, enabling observing personnel to focus on other demanding duties.

ASOS data is accessible through a variety of media never before available from a surface observing site. Local, on-site video screen displays are available on the Operator Interface Device (OID) and the Video Display Unit (VDU). Additional video monitor hook-ups can be made available to airlines and other external users at the airport. Authorized remote users can acquire a wide variety of ASOS data through the a remote user dial-in port. Computer-generated voice message are provided by ASOS for local FAA radio broadcast to pilots and are made available for general aviation use through a dial-in telephone number for each location. NWS and FAA long-line users receive routine distribution of all ASOS generated METAR. In addition, NWS long-line users also receive ASOS generated Standard Hydrometeorological Exchange Format (SHEF), and daily and monthly summary messages. The wealth of high-quality ASOS data now available to users offers new and exciting opportunities for meeting future environmental data needs.

Since the last *ASOS User's Guide* was first published in June 1992, there have been numerous system changes. These changes include the transition from the Surface Aviation Observation (SAO) code to the METAR code in 1996; the implementation of new software loads into ASOS, up to and including software Version 2.6; the incorporation of various sensor enhancements and improvements, including modification to the Heated Tipping Bucket precipitation accumulation gauge, the hygrothermometer and anemometer; and the incorporation of the Freezing Rain and Lightning Sensors into the ASOS sensor suite. Additional planned product improvement efforts are underway to further expand and improve the capabilities of ASOS. These changes and improvement efforts are described in this updated version of the *ASOS User's Guide*.

Table of Contents

CHAPTER ONE	1
1.0 Introduction	1
1.1 Purpose and Scope	1
1.2 Background	1
1.3 Total Surface Observation Concept	2
1.4 Quality Control	2
1.5 General Conventions	3
CHAPTER TWO	5
2.0 System Description	5
2.1 System Components	5
2.1.1 ASOS Sensor Groups	5
2.1.2 Acquisition Control Unit	5
2.1.3 Operator Interface Device	9
2.2 ASOS Data Outlets	9
2.3 ASOS Data Types	9
2.4 METAR Elements	9
2.5 Automated METAR vs. Manual METAR	10
CHAPTER THREE	11
3.0 Automating the Objective Weather Elements	11
3.1 Ambient and Dew Point Temperature	11
3.1.1 Ambient/Dew Point Temperature Sensor	11
3.1.2 Ambient Temperature/Dew Point Temperature Algorithm	12
3.1.3 Ambient Temperature/Dew Point Temperature Strengths and Limitations	13
3.2 Wind	14
3.2.1 Wind Sensor	15
3.2.2 Wind Algorithm	15
3.2.2.1 Wind Direction and Speed	15
3.2.2.2 Wind Character	16
3.2.2.2a Gusts	16
3.2.2.2b Variable Wind	16
3.2.2.2c Squalls	17
3.2.2.3 Wind Remarks	17
3.2.2.3a Wind Shift	17
3.2.2.3b Peak Wind	18
3.2.3 Wind Strengths and Limitations	18
3.3 Pressure	18
3.3.1 Pressure Sensor	18
3.3.2 Pressure Algorithm	18
3.3.3 Pressure Strengths and Limitations	19
3.4 Precipitation Accumulation	19

Table of Contents

3.4.1	Heated Tipping Bucket Precipitation Gauge	20
3.4.2	Precipitation Accumulation Algorithm	20
3.4.3	Precipitation Accumulation Strengths and Limitations	22
CHAPTER FOUR	23
4.0	Automating the Subjective Weather Elements	23
4.1	Automating Sky Condition	23
4.1.1	Cloud Height Indicator Sensor	23
4.1.2	Sky Condition Algorithm	24
4.1.2a	Meteorological Discontinuity Sensors	25
4.1.2b	Back-Up Sensors	26
4.1.3	Sky Condition Strengths and Limitations	26
4.2	Automating Surface Visibility	27
4.2.1	Principles in Visibility Automation	28
4.2.2	Forward Scatter Sensor	29
4.2.3	Visibility Algorithm	29
4.2.3a	Meteorological Discontinuity Visibility Sensor	30
4.2.3b	Back-Up Visibility Sensor	31
4.2.4	Visibility Strengths and Limitations	31
4.3	Automating Present Weather and Obscurations	32
4.3.1	Single Site Lightning Sensor	32
4.3.2	Single Site Lightning Sensor Algorithm	32
4.3.3	Automated Lightning Detection and Reporting System (ALDARS)	33
4.3.4	ASOS Lightning Sensor Strengths and Limitations	33
4.3.5	Precipitation Identification Sensor	34
4.3.6	PI Algorithm	35
4.3.7	PI Strengths and Limitations	36
4.3.8	Freezing Rain Sensor	36
4.3.9	FZRA Algorithm	37
4.3.10	FZRA Strengths and Limitations	38
4.3.11	Obscuration Algorithm	38
4.3.12	Obscuration Algorithm Strengths and Limitations	39
CHAPTER FIVE	41
5.0	Explanations/Examples of ASOS Observations	41
5.1	5-Second Wind Updates	41
5.2	One-Minute Observations	41
5.3	ASOS Aviation Routine Weather Reports	41
5.3.1	Backup and Augmentation	42
5.3.2	Missing vs. Non-Event Data	42
5.3.3	Estimated Data	43
5.3.4	Examples of METAR/SPECI Reports	43

Table of Contents

5.4 Auxiliary Data	46
5.5 Standard Hydrometeorological Exchange Format (SHEF) Messages	46
5.5.1 SHEF 15-Minute Precipitation Criteria Message	48
5.5.2 SHEF Hourly Routine Precipitation Message	48
5.6 Daily and Monthly Summaries	48
5.6.1 Daily Summary Message	48
5.6.2 Monthly Summary Message	50
5.7 ASOS High-Resolution Sensor Data	50
CHAPTER SIX	53
6.0 ASOS Data Outlets	53
6.1 Interactive Video Screen Displays	53
6.2 Non-Interactive Screen Displays	53
6.3 ASOS Printer	53
6.4 Long-Line Dissemination	54
6.5 Computer-Generated Voice Messages	54
CHAPTER SEVEN.....	59
7.0 Introduction	59
7.1 Data Not Provided by ASOS	59
7.2 Planned Product Improvement	59
7.2.1 Ice-Free Wind Sensor	60
7.2.2 Dew Point Sensor	60
7.2.3 Ceilometer/Sky Condition	60
7.2.4 All-Weather Precipitation Accumulation Gauge	60
7.2.5 Enhanced Precipitation Identification	61
7.2.6 Sunshine	61
7.2.7 Schedule	61
7.3 Summary	61
Appendices	
Appendix A: ASOS Video Screens	A1-11
Appendix B: ASOS Initial Operation Capabilities	B1-2
Appendix C: Content of ASOS-Generated METAR: A Quick Reference Guide	C1-2
Appendix D: ASOS Voice Vocabulary	D1
Appendix E: Acronyms	E1

Table of Contents

Figures

Figure 1.	ASOS Quality Control Concept	4
Figure 2.	ASOS Combined Sensor Group	6
Figure 3.	Additional Sensor Group	7
Figure 4.	Availability of ASOS Data	8
Figure 5.	ASOS Hygrothermometer	11
Figure 6.	ASOS Anemometer	14
Figure 7.	ASOS Pressure Sensor	19
Figure 8.	ASOS Heated Tipping Bucket	20
Figure 9.	Laser Beam Ceilometer	23
Figure 10.	Example Of Cloud "Hit" At 4,500 Feet	24
Figure 11.	Example Of "Unknown Hit"	24
Figure 12.	Example of Packing Effect	27
Figure 13.	Forward Scatter Visibility Sensor	28
Figure 14.	Visibility Sensor—Top View	29
Figure 15.	Lightning Sensor	32
Figure 16.	The Precipitation Identification Sensor	34
Figure 17.	Freezing Rain Sensor	37
Figure 18.	ASOS Network Data Flow—Initial Configuration (1997)	55
Figure 19.	ASOS Network Data Flow—Final Configuration	56

Tables

Table 1.	Temperature Sensor—Range, Accuracy Resolution	12
Table 2.	Wind Sensor—Range, Accuracy, Resolution	15
Table 3.	Cover ASOS Cloud Amount Report—Percent of Sky	25
Table 4.	Criteria for Reporting a Meteorological Discontinuity Ceiling Remark	26
Table 5.	Visibility Sensor—Accuracy in Statute Miles	30
Table 6.	Present Weather Reporting Hierarchy	38
Table 7.	ASOS Report of Freezing/Frozen Phenomena	38
Table 8.	ASOS Report of Present Weather	39
Table 9.	ASOS High-Resolution Data	51
Table 10.	Weather Elements Not Reported by ASOS	59

CHAPTER ONE

1.0 Introduction

Since the first aircraft took flight, weather observations have been essential for safe aviation operations. Over the years, the National Airspace System (NAS) has expanded to thousands of flights and millions of passenger and cargo miles a day. Paralleling this expansion has been the demand for increased weather observations. In recent years the National Weather Service (NWS), the Federal Aviation Administration (FAA), and the Department of Defense (DOD) have collectively expended over 1,000 staff-years annually to create and disseminate manual weather observations. This expanding demand on human resources spurred the development of automated sensors and reporting systems to provide surface weather observations.

With the advent of new reliable and sophisticated sensors and computer technology in the 1970s, it became increasingly practical to automate many observing functions. This potential came to fruition with development and testing of the Automated Surface Observing System (ASOS) in the 1980s, and its deployment and implementation in the 1990s. By the turn of the century, over 900 airports will have ASOS.

The primary function of the ASOS is to provide minute-by-minute observations and generate the basic Aviation Routine Weather Report (METAR) and Aviation Selected Special Weather (SPECI) report. This information is essential for safe and efficient aviation operations, and is used by the public to plan day-to-day activities. ASOS also provides valuable information for the hydrometeorologic, climatologic, and meteorologic research communities.

1.1 Purpose and Scope

The purpose of the *ASOS User's Guide* is to familiarize users with the unique characteristics of ASOS data, how to interpret it, and optimize its use. The primary audience for the *ASOS User's Guide* includes pilots, air traffic controllers, meteorologists, hydrologists, climatologists, and other users of surface weather observations. It is assumed that readers are familiar with the current Federal Meteorological Handbook Number 1 (FMH-1), which describes the observing practices, coding, and reporting standards for surface weather observations.

This *User's Guide* provides information applicable to all ASOS units, whether they are sponsored by the NWS, FAA, or DOD. The *Guide* covers all essential aspects of system operation, including data acquisition, processing, and report formatting and dissemination. This *Guide* is by no means exhaustive and additional information is referenced.

The *ASOS User's Guide* is organized into four topical areas. Each topical area includes one or more chapters. The information within these topical areas flows from a general introduction to specific core detail and finally to a conclusion or summary.

The first topical area provides a general overview (Chapters 1-2). The second topical area discusses the automation of the objective weather elements (Chapter 3) and automation of the subjective weather elements (Chapter 4). These chapters describe the sensor operation principles, the algorithms, and the strengths and limitations of ASOS in reporting each element. The next topical area provides specific examples and explanations of ASOS output (Chapters 5-6). Finally Chapter 7 provides a look to the future and a conclusion. Appendices provide additional detail. This includes examples of ASOS video screens, performance specifications, and a quick reference guide to the content of the ASOS generated METAR/SPECI reports.

1.2 Background

The earliest fielded automated systems, the Automated Meteorological Observing System (AMOS) and the Remote Automated Meteorological Observing System (RAMOS), were deployed in the 1960s and 1970s. These systems reported only the objective elements of ambient and dew point temperature, wind (speed and direction), and pressure.

The more complex, spatially observed elements of sky condition and visibility had to await advances in sensor technology and improvements in computer processing. These goals were initially achieved by developing and fielding the Automated Observation (AUTOB) in the early 1970s. It was only when these more subjective elements could be automated that the opportunity arose to develop a fully automated observation system. The first such system was developed during the joint FAA-NWS Aviation Automated Weather Observing System (AV-AWOS) experi-

ments performed between 1973 and 1978. In the 1980s, further advances in technology finally permitted the NWS, FAA, and DOD to develop a practical, fully automated observing system for nationwide use.

1.3 Total Surface Observation Concept

ASOS provides the basic surface weather observation at many airports. At selected airports, an observer may add information to the ASOS observation. These additions are considered important for safe and efficient operations in the airport/terminal area and provide backup observations for those elements that ASOS normally reports.

Although ASOS is the primary source of surface observational data in the United States, other surface observing networks, distinct from ASOS, provide supplementary data for forecasting and other specific interests. These networks include severe weather spotter networks, hydrological reporting networks, synoptic and climatological observing networks, and cooperative observing networks. Data from these sources are not derived from ASOS and are not provided as part of the ASOS observation. This information is included in separate data sets or products. Examples of this information are severe weather reports (tornado/funnel cloud sightings, etc.), snow depth, water equivalent of snow on the ground, and middle and high cloud information (height, amount, and type).

In the modernized weather service, new and improved technologies such as satellite, Doppler Weather Surveillance Radar (WSR-88D), and lightning detection networks provide valuable weather information separate from data reported by the ASOS. By integrating these data, meteorologists can now obtain a more accurate and complete depiction of the weather than what can be obtained only from a single source.

1.4 Quality Control

The automation of surface observations reduces or eliminates direct human involvement in acquiring (sensing, collecting), processing (assessing, formatting, documenting), and disseminating (transmission, display, broadcast) surface observations. Even though the ASOS is highly automated and reliable, effective Quality Control (QC) of ASOS products is critical for ensuring the high level of trust in the automated output (Figure 1).

There are three cascading levels of quality control for ASOS. Each level focuses on a different temporal and spatial scale.

- Level 1 is performed on-site, in real-time before an observations is transmitted.
- Level 2 is performed at a Weather Forecast Office (WFO) for a designated area, about the size of a state, usually within 2 hours after the scheduled observation transmission time.
- Level 3 is performed centrally on all ASOS METARs nationwide, usually about 2 hours after the scheduled transmission time.

Level 1—At the Site

Built into each ASOS are automated self-diagnostics and QC algorithms. These QC algorithms operate on raw sensor data; they prevent questionable data from being included in the One-Minute-Observation (OMO) or the transmitted METAR/SPECI. When the ASOS detects either a qualifying degree of system degradation, component failure, or data error, the relevant data are excluded from report processing and a Maintenance Check Indicator (\$) is appended to the METAR/SPECI report. If sufficient raw data are not available for report processing, the element is not included in the OMO or METAR/SPECI report. The \$ is used to indicate that maintenance may be needed but does not necessarily mean that the data are erroneous. On-site observers may also augment and/or backup the ASOS METAR/SPECI data at selected locations. These observers provide an immediate data check and often catch problems before the observation is transmitted.

Level 2—Area

WFO personnel routinely monitor and assess the availability and meteorological quality of long-line transmitted METARs and SPECIs from all ASOS locations in their county warning area (CWA). This quality control usually occurs within 1- 2 hours after the data are transmitted. If data are suspect, the WFO staff investigates the problem, informs points of contact (either the on-site observer, maintenance technician, or associated FAA Flight Service Station) and coordinates corrective action to ensure that a quality observation is provided, or suspends the questionable observation pending resolution of a problem. The goal at the area level is to correct a problem or prevent any additional erroneous data from being transmitted. When a system problem is detected, a maintenance technician is notified. Maintenance technicians are based at selected NWS offices and service all NWS and FAA ASOS's within their area of responsibility. The Navy and Air Force perform maintenance on their own ASOSs.

Level 3—National

National QC operations are centered at the ASOS Operations and Monitoring Center (AOMC). It is staffed 24-hours a day and provides an 800 phone-in number for trouble calls. AOMC technicians routinely monitor the long-line transmitted ASOS hourly METAR. To help with this monitoring, two types of automated messages are routinely provided to the AOMC. These messages identify: (1) those METAR/SPECI reports with a \$ appended and (2) those METAR not received within the standard Time-Of-Transmission window. These messages are provided by the NWS Telecommunication Gateway (NWSTG), which is collocated with the AOMC in the NWS Systems Operations Center (SOC).

When a problem is encountered, AOMC technicians open a trouble report, alert the responsible ASOS Electronic Technician and/or NWS office to take appropriate action, and monitor progress toward resolution. The AOMC may also coordinate with the appropriate FAA Weather Message Switching Center Replacement (WMSCR) facility to resolve FAA National Airspace Data Interchange Network (NADIN) communications problems that affect long-line transmission of ASOS reports. AOMC QC action is usually initiated after hourly METAR data are missing for 2 hours.

The AOMC performs other vital functions, such as downloading critical operational information to the ASOS, keeping accurate clock synchronization, and maintaining data for system reinitialization, such as field elevation, magnetic declination, phone numbers, etc.

The goal at the national level is to maintain uniform system integrity and prevent problems in data from continuing for extended periods of time.

Automated QC messages are generated at the National Center For Environmental Prediction (NCEP) hourly and made available to WFOs. These messages identify horizontally inconsistent and possibly unrepresentative observations through comparison of selected elements in the hourly METAR with a corresponding computer-generated Optimal Interpolation (OI) analysis field. The evaluated elements are:

- Wind direction and speed
- Potential temperature (used as a surrogate for ambient temperature)
- Dewpoint temperature
- Sea-level pressure.

Those METAR elements that differ from the corresponding OI value by more than the allowable criteria are flagged as suspect and included in the NCEP CQ message. Other automated QC monitoring programs are operational at the local WFO and alert the staff when data elements or whole observations are missing, usually within 1 hour.

The National Climatic Data Center (NCDC) performs additional quality control prior to archive.

1.5 General Conventions

The time convention used in this document to describe the valid times and schedules used by ASOS is:

DD:HH:MM:SS

Where:

DD = Date; $01 \leq DD \leq 31$

HH = Hour (24-hour clock); $00 \leq HH \leq 23$

MM = Minute; $00 \leq MM \leq 59$

SS = Second; $00 \leq SS \leq 59$

H+MM = Minutes past the current hour.

M+SS = Seconds past the current minute.

For example, a time period from 56 minutes past the previous hour to 50 minutes past the current hour would be referenced as: “-H+56 to H+50.”

The times specified in this document are in either Local Standard Time (LST) or Universal Coordinated Time (UTC), alternately referred to as Zulu Time (Z).

In the descriptions of the algorithms, if less than 75 percent of the maximum amount of data used in the computation of any parameter is available, the parameter is not reported. Unless otherwise noted, all midpoint fractional values are rounded *down* to the nearest appropriate value. All other values are rounded in accordance with normal rounding procedures.

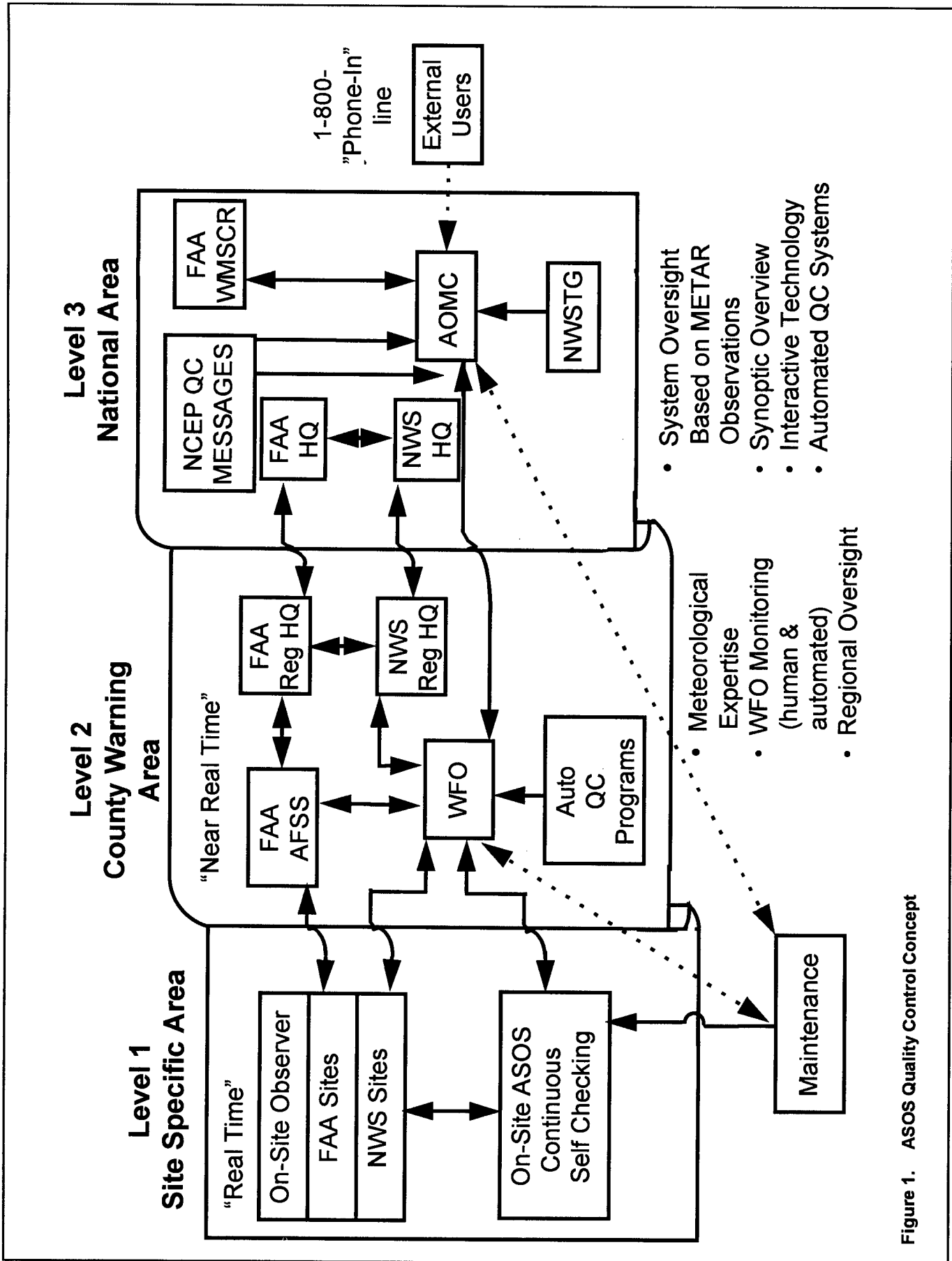

Figure 1. ASOS Quality Control Concept

CHAPTER TWO

2.0 System Description

The ASOS performs all the basic observing functions, including the acquisition, processing, distribution, transmission, and documentation of data.

2.1 System Components

The ASOS consists of three main components. The first two components are at all ASOS locations; the third component is found only at airports at which observer augmentation/backup support is provided.

- Sensor group(s), consisting of individual weather sensors and a Data Collection Package (DCP)
- The Acquisition Control Unit (ACU)
- The Operator Interface Device (OID)

2.1.1 ASOS Sensor Groups

The ASOS sensors continuously sample and measure the ambient environment, derive raw sensor data and make them available to the collocated DCP. These raw sensor data include visibility extinction coefficients, ceilometer cloud hits, freezing precipitation resonant frequencies and other sensor data. These data are processed as preliminary input into the observation algorithms. The ASOS consists of the following basic complement of sensors¹:

- Ceilometer, Cloud Height Indicator [CHI] Sensor (one to three sensors per site)
- Visibility Sensor (one to three sensors per site)
- Precipitation Identification (PI) Sensor
- Freezing Rain (ZR) Sensor (not planned to be included where ZR potential is nil)
- Lightning Sensor (only at selected sites)
- Pressure Sensors (two sensors at small airports; three sensors at larger airports)
- Ambient/Dew Point Temperature Sensor
- Anemometer (wind direction and speed sensor)
- Precipitation Accumulation Sensor (Heated Tipping Bucket [HTB] Gauge)

¹Other sensors are under development and may be added at a later time.

Sensors are sited in accordance with guidance stated in the Federal Standards for Siting Meteorological Sensors at Airports (FCM-S4-1987), published by the Office of the Federal Coordinator for Meteorological Services and Supporting Research (OFCM). At virtually all locations, the pressure sensors are located indoors within the ACU.

The field complement of ASOS sensors are typically located near the Touchdown Zone (TDZ) of the primary designated instrument runway. If the TDZ site was found unacceptable, the Center Field (CF) location is the most likely alternate location. The field sensor array is referred to as the "ASOS Combined Sensor Group." At larger airports or airports where the operational need is justified, additional sensors may be strategically located at an other location to provide additional weather information ("Meteorological Discontinuity Sensor Group") or backup sensor capabilities ("Backup Sensor Group"). These additional sensor groups generally consist of a ceilometer, a visibility sensor, and a collocated DCP². Figure 2 shows a typical ASOS Combined Sensor Group. Figure 3 shows an optional ASOS "Meteorological Discontinuity" or "Backup" Sensor Group.

A DCP is located with each sensor group. It continually gathers and processes raw data from the adjacent sensors (e.g., voltages, extinction coefficients, data counts) and conditions these data before transmission to the ACU. Data conditioning may include such processes as sampling, formatting, and scaling.

2.1.2 Acquisition Control Unit

The ACU, which is the central processing unit for the ASOS, is usually located inside a climate controlled structure, such as an observing office or control tower building. It ingests data from the DCP(s) and pressure sensors, and is capable of accepting information from the FAA New Generation Runway Visual Range (NGRVR) system.

The ACU performs final processing, formatting, quality control, storage and retrieval of the data, and makes ASOS data available to users through various outlets. A brief description of the various ASOS data outlets and data

²At the Hub airports, the PI sensor will be included in the Touchdown Sensor Group if it is located at the TDZ of the primary instrument runway.



Combined Sensor Group

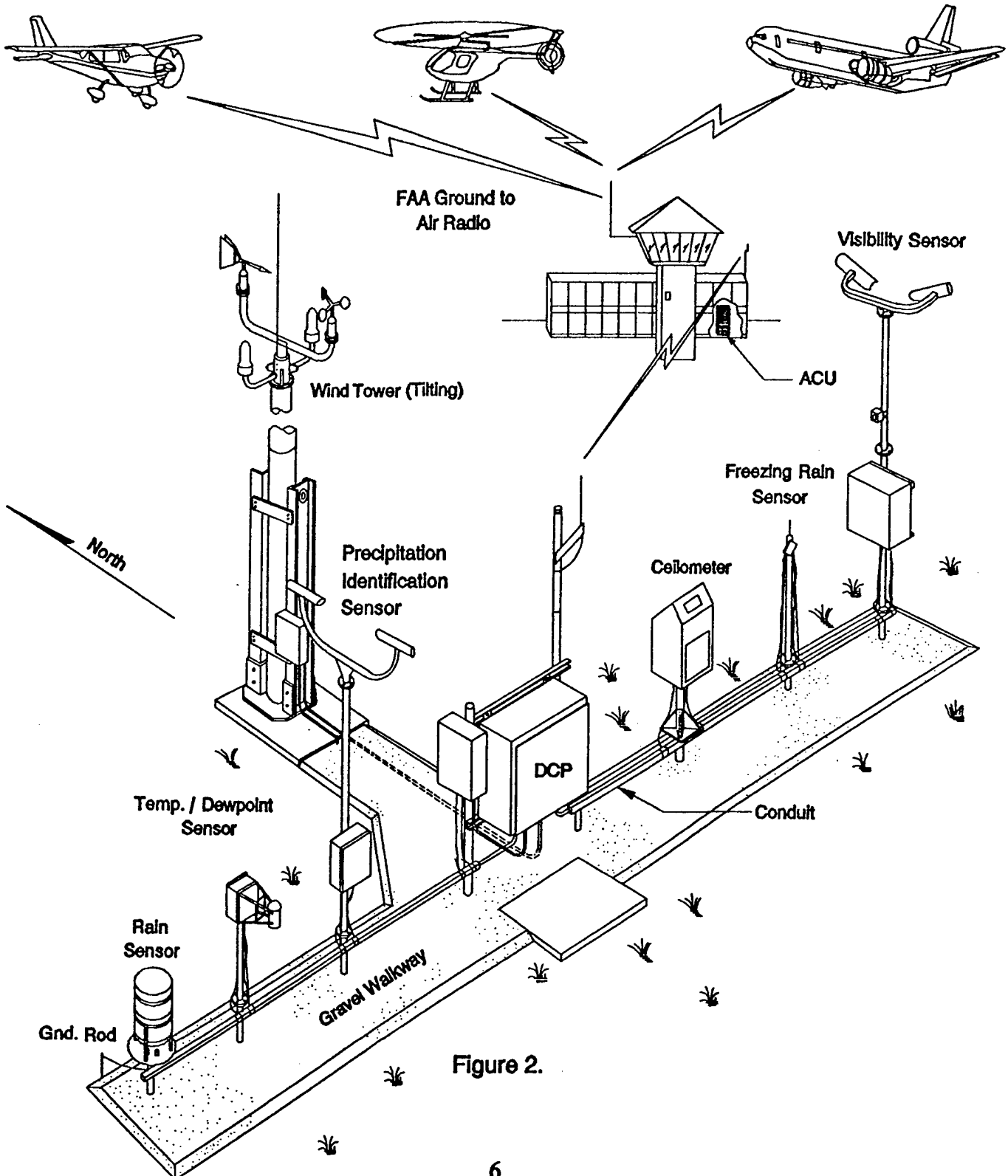

Figure 2.



Meteorological Discontinuity/Backup Sensor Group

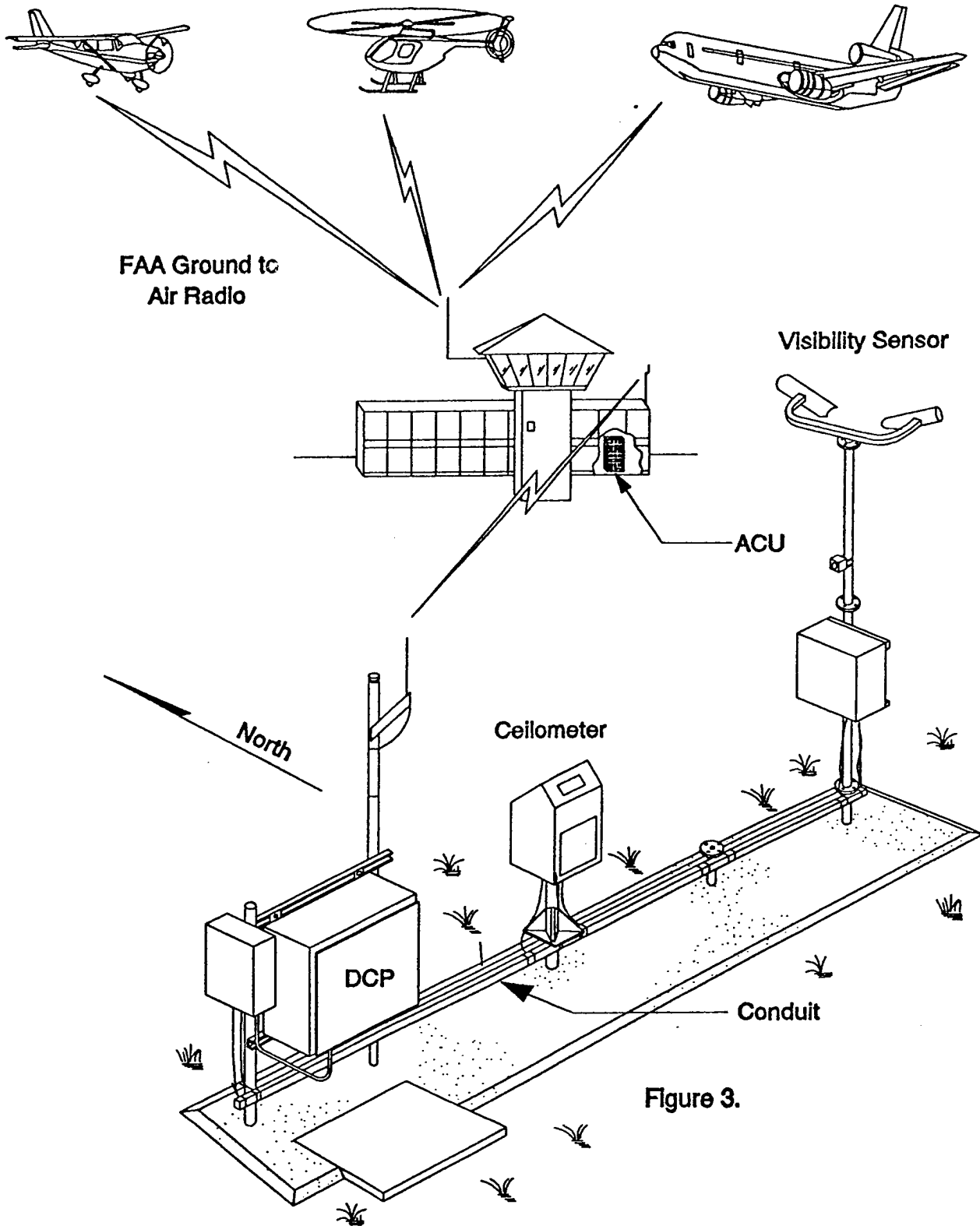

Figure 3.

ASOS DATA OUTLET												
ASOS DATA TYPE	OID/REMOTE USER INTERACTIVE SCREENS					ON-SITE SCREEN	ON-SITE PRINTER (STAFFED SITES)	LONG-LINE			COMPUTER GENERATED VOICE	
	OBSVR LEVEL (1)	ATC LEVEL (1)	MAINT LEVEL	SYS MGR LEVEL	UN-SIGNED USER LEVEL			NWS AFOS	NWS AWIPS	FAA NADIN	GROUND-TO-AIR RADIO	TELEPHONE DIAL-IN
OMO DATA	◆	◆	◆	◆	◆	VDU	◆	◆ ²	◆ ²	◆ ³	◆ ³	◆ ³
METAR DATA	◆	◆	◆	◆	◆	◆	◆	◆	◆	◆ ³	◆ ³	◆ ³
AUXILIARY DATA	◆	◆	◆	◆	◆	◆	◆					
SHEF DATA	◆		◆	◆	◆		◆	◆	◆ ⁴			
MAINTENANCE DATA	◆		◆	◆	◆		◆					
DAILY SUMMARY DATA	◆		◆	◆	◆		◆	◆		◆		
MONTHLY SUMMARY DATA	◆		◆	◆	◆		◆	◆		◆		

- ◆ Data type available through data outlet
- 1 This level not available remotely
- 2 Selected OMO data provided once every 5 or 15 minutes upon request
- 3 Either OMO or last transmitted METAR/SPECI - Not both
- 4 Available through FAA ADAS interface

Figure 4. Availability of ASOS Data

types is summarized in Figure 4. Additional details and examples may be found in Chapters 6 and 7.

2.1.3 Operator Interface Device

The Operator Interface Device (OID) is the primary means through which an on-site observer enters back-up or augmentation observations into the ASOS METAR/SPECI report. It consists of a keyboard, and video screen interfaced directly with the ACU either through hardwire or telephone line. Various OID screen displays are available; see Appendix A for examples.

2.2 ASOS Data Outlets

The ASOS Peripheral Data Outlets include:

- The ASOS Operator Interface Device (OID) and remote dial-in user interactive video screen displays. Examples of various OID video screen displays are shown in Appendix A
- On-site video display screens. These include the Video Display Unit (VDU) screens, and user-provided video monitors
- On-site printer hard copy (at OID equipped locations), when required
- Long-line dissemination of coded messages through NWS and FAA communications networks. Long-line networks are described in Section 6.3
- Computer-generated voice (available through FAA radio broadcast to pilots, and general aviation dial-in telephone lines). Examples of computer-generated voice messages are given in Section 6.4

2.3 ASOS Data Types

The various ASOS data types available through these outlets include:

- One-Minute Observation (OMO) data (content same as METAR/SPECI data)
- Aviation Routine Weather Reports (METAR) and Aviation Selected Special Weather Reports (SPECI). At staffed locations, SPECI messages for tornadic or volcanic activity are manually composed and disseminated through ASOS when these conditions are observed (described in Section 5.3)
- Auxiliary data display (described in Section 5.4)
- Standard Hydrometeorological Exchange Format (SHEF) messages (described in Section 5.5)
- Maintenance Data (raw sensor data, system diagnostics, system status) (examples given in Appendix A)

- Daily and Monthly Summary messages (described in Section 5.6)

2.4 METAR Elements

The ASOS will automatically report the following surface weather elements in the METAR:

- Wind: Direction (tens of degrees - true), Speed (knots), and Character (gusts)
- Visibility up to and including 10 statute miles
- Runway Visual Range (RVR) at selected sites
- Basic Present Weather Information (type and intensity): Rain, Snow, Freezing Rain, Squalls
- Obstructions: Fog, Mist, Haze, and Freezing Fog
- Sky Condition: Cloud Height and Amount (CLR, FEW, SCT, BKN, OVC)³ up to 12,000 feet above ground level
- Ambient Temperature, Dew Point Temperature (degrees Celsius)
- Pressure: Altimeter Setting in inches of mercury (Hg), and Sea-level Pressure (SLP) in Hectopascals (hPa)⁴ in Remarks
- Automated, Manual, and Plain Language Remarks (depending on service level) including: Volcanic Eruption (plain language), Tornadic Activity (plain language), Wind Shift, Tower Visibility, Beginning and Ending of Precipitation, Virga (plain language), Significant Cloud Types (plain language), SLP, and Other Significant (Plain Language) Information
- Additive and Automated Maintenance Data including: 3, 6, 24-hour Precipitation Amount, Hourly Temperature and Dew Point, 6-hour Maximum and Minimum Temperatures, 3-hour Pressure Tendency, various sensor status indicators, and maintenance check indicator (\$).

The ASOS Capability to report these elements is summarized in Appendix B. The content of the ASOS METAR/SPECI is described in the following chapters and is summarized in Appendix C. In the future, ASOS may also provide additional information on snowfall, hail, drizzle, and sunshine duration (see Chapter 7 for further details).

³In the METAR code cloud amounts are depicted as either Clear (CLR), Few (FEW), Scattered (SCT), Broken (BKN), or Overcast (OVC)

⁴A Hectopascal (hPa) value is equivalent to a millibar (mb), i.e., 1012 hPa = 1012 mb.

2.5 Automated METAR vs. Manual METAR

In form, the unattended ASOS METAR and the attended ASOS (Observer oversight) METAR look very much alike. For example, under the same circumstances, the ASOS would report:

**KDEN 281950Z AUTO 11006KT 6SM HZ SCT080
15/12 A3013 RMK AO2 SLP123**

while the observer who is editing the ASOS might report:

**KDEN 281950Z 11006KT 5SM HZ SCT080
BKN140 15/12 A3013 RMK AO2 FEW ACC W SLP123**

Notice that both METARs contain the station ID, observation type, time, wind, visibility, obstructions, sky condition, ambient temperature, dew point temperature, altimeter setting, and sea-level pressure (in remarks).

The automated observation indicates the station type as "AUTO" which signifies an unattended observation (i.e., Observer not logged onto ASOS for back-up or augmentation), and identifies the system as one capable of reporting present weather (AO2).

The second observation indicates that the Observer logged onto the system (AUTO is missing). The Observer augmented sky condition for clouds above 12,000 feet and

added information in the Remarks section about cloud type and location which ASOS cannot provide. This is just one example. Other detailed examples are given in Chapter 5.

To fully appreciate these examples, the *ASOS User's Guide* first examines each of the weather elements reported by the ASOS and compares the manual and automated observations in terms of sensors used, the observing procedures employed, and reporting capabilities. Automated observing concepts are also discussed for greater clarity and understanding. The specific chapter-by-chapter breakdown is as follows:

- **Chapter 3** discusses the more objective and directly measured (i.e., non-visual) elements such as ambient temperature, dew point temperature, wind, pressure, and precipitation accumulation.
- **Chapter 4** discusses the more subjective, and to some extent, indirectly measured (i.e., visual) elements of sky condition, visibility, present weather (phenomena and obstructions).
- **Chapter 5** provides examples of ASOS weather reports, messages, and summaries.
- **Chapter 6** discusses the outlets through which the ASOS data are available.
- **Chapter 7** describes those elements not currently provided by ASOS, future product improvement plans, and alternate means through which these data are now available or may be available in the future.

CHAPTER THREE

3.0 Automating the Objective Weather Elements

The “objective” weather elements are defined as ambient and dew point temperature, wind, pressure, and precipitation accumulation. These elements are classified as “objective” because they are more simply and directly measured and are easier to automate than other elements. This chapter describes how ASOS reports objective elements.

3.1 Ambient and Dew Point Temperature

Ambient and dew point temperature reports are among the most widely disseminated of all the weather elements in the surface observation. Because of keen public interest, nearly all radio and most television stations report temperature and humidity at least once an hour. Ambient and dew point temperature are vital in determining aircraft performance and loading characteristics and are critical for accurate weather forecasts. To meet these needs, ASOS provides a 5-minute average ambient air and dew point temperature every minute.

3.1.1 Ambient/Dew Point Temperature Sensor

Both the manual and automated temperature sensors directly measure the ambient dry-bulb and the dew point temperatures. The hygrothermometer used in the ASOS is a modern version of the fully automated “HO-83” hygrothermometer, first used operationally in 1985. This instrument uses a platinum wire Resistive Temperature Device (RTD) to measure ambient temperature and a chilled mirror to determine dew point temperature.

The RTD operates on the principle that electric resistance in a wire varies with temperature. This RTD is located in the stream of aspirated air entering the sensing unit and assumes the ambient air temperature.

To determine dew point temperature, a mirror is cooled by a thermoelectric or Peltier cooler until dew or frost begins to condense on the mirror surface. The body of the mirror contains a platinum wire RTD, similar to that used for ambient temperature. This RTD assumes the mirror’s temperature, which is held at the dew point temperature.

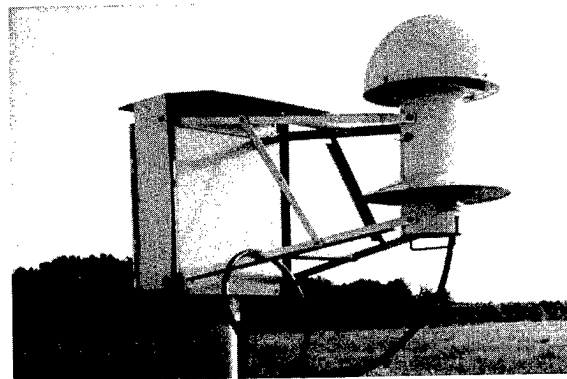

Figure 5. ASOS Hygrothermometer

When this condition occurs, the mirror’s surface is in vapor pressure equilibrium with the surrounding air (i.e., has reached the saturation vapor pressure). The temperature required to maintain this equilibrium is, by definition, the dew point temperature.

Optical techniques are used to detect the presence of surface condensation. Within the hygrothermometer, a beam of light from a small Light Emitting Diode (LED) is directed at the surface of the mirror at a 45 degree angle. Two photo-resistors are mounted to receive the reflected light. The “direct” sensor is placed at the reflection angle and receives a high degree of light when the mirror is clear. The indirect sensor is placed to receive light scattered when the mirror is clouded with visible condensation, (i.e., dew or frost formation).

In normal operation, a feedback loop controls an electric heat pump running through a cooling-heating cycle, which cools the mirror until dew or frost is formed; it then heats the mirror until the condensate (dew or frost) is evaporated or sublimed. This cycle nominally takes about 1 minute to complete.

As the mirror’s cloudiness increases, the “direct” sensor receives less light and the “indirect” sensor receives more light. When the ratio of indirect to direct light reaches an adaptive criterion value, the mirror is considered to be at the dew point temperature. The adaptive criterion value (ratio of indirect to direct light) is adjusted once a day to compensate for residual contamination on the mirror due to dust and other airborne particulates.

Table 1. Temperature Sensor—Range, Accuracy Resolution

Parameter	Range	RMSE	Max Error	Resolution
Ambient Temperature	-80°F to -58°F	1.8°F	± 3.6°F	0.1°F
	-58°F to +122°F	0.9°F	± 1.8°F	
	+122°F to +130°F	1.8°F	± 3.6°F	
Dew Point Temperature	-80°F to -0.4°F	3.1°F to 7.9°F	4.5°F to 13.9°F	0.1°F
	-0.4°F to +32°F	2.0°F to 7.9°F	3.4°F to 13.9°F	
	+32°F to +86°F	1.1°F to 4.7°F	2.0°F to 7.9°F	

Since a clean mirror needs relatively less indirect light to determine when dew has formed than a dirty mirror, the mirror is heated once a day to recalibrate the reference reflection expected from a dry mirror. This procedure compensates for a possible dirty or contaminated mirror and redefines adaptive criterion value used to determine when dew or frost has occurred. This once per day recalibration nominally takes about 15 minutes.

The ASOS hygrothermometer meets all NWS specifications for measuring range, accuracy, and resolution. The specifications for accuracy are given in Root Mean Square Error (RMSE) and Maximum (MAX) Error. Specifications are listed in Table 1.

The RMSE for Dew Point Temperature is given as a range of values and is dependent on the Ambient Temperature minus the Dew Point Temperature value (i.e., Dew Point Depression [DD]). The low end of the RMSE and MAX Error range is for a DD of 0°F; the high end of the Error range is for a DD of 63°F.

3.1.2 Ambient Temperature/Dew Point Temperature Algorithm

Both ambient temperature and dew point temperature are considered conservative elements (i.e., continuous in space, and slowly and smoothly changing in time). Based on this characteristic, time-averaging over a short period is the preferred method of measurement.

The ASOS hygrothermometer continually measures the ambient temperature and dew point temperature and provides sample values approximately six times per minute. Processing algorithms in the hygrothermometer use these samples to determine a 1-minute average temperature and dew point valid for a 60-second period ending at M+00. These data are passed to the ACU for further processing.

Once each minute the ACU calculates the 5-minute average ambient temperature and dew point temperature from the 1-minute average observations (provided at least 4 valid 1-minute averages are available). These 5-minute averages are rounded to the nearest degree Fahrenheit, converted to the nearest 0.1 degree Celsius, and reported once each minute as the 5-minute average ambient and dew point temperatures. All mid-point temperature values are rounded up (e.g., +3.5°F rounds up to +4.0°F; -3.5°F rounds up to -3.0°F; while -3.6 °F rounds to -4.0 °F).

The ACU performs all temperature averaging functions. It also performs a number of data quality tests on the ambient and dew point temperatures, including upper and lower limit checks, a rate of change check, and a cross comparison. The current 1-minute ambient and dew point temperature are compared against these limits. The upper and lower limits are +130°F to -80°F for ambient temperature and +86°F to -80°F for dew point temperature.

If the current 1-minute ambient or dew point temperature differs from the last respective, non-missing, 1-minute reading in the previous 2 minutes by more than 10°F, it is marked as "missing." The current 1-minute ambient temperature is also compared against the current 1-minute dew point temperature to ensure the dew point is not higher. If the dew point temperature exceeds the ambient temperature by 2°F or less, the dew point temperature is set equal to the ambient temperature. If the dew point temperature exceeds the ambient temperature by more than 2°F, the 1-minute dew point temperature is set to "missing."

If, within the past 5 minutes, there are at least four valid (i.e., non-missing) 1-minute ambient and dew point temperatures, the respective 5-minute averages are computed and reported in degrees Celsius in the OMO and METAR. If there are less than four valid 1-minute average ambient or dew point temperatures within the past 5 minutes, ASOS does not compute the current 5-minute average for ambient or dew point temperature. When this occurs, ASOS uses the most recent 5-minute average value calculated within the past 15 minutes.

If the ASOS has not recorded a valid 5-minute average ambient or dew point temperature within the past 15-minutes, no ambient or dew point temperature is reported and the sensor failure notation is entered into the ASOS system maintenance log (SYSLOG). This 15-minute "hold-off" allows the daily 15-minute calibration heat cycle to occur without adverse affect. The current 1-minute average ambient temperature and the 5-minute average ambient temperature are updated once each minute and stored in memory for 12 hours. These stored data are used in further computation:

- Once each minute, ASOS uses the running 5-minute average ambient temperature to update the hourly maximum and minimum ambient temperatures. At the end of the hour (H+59), the cumulative maximum and minimum ambient temperatures for the hour and the minute(s) they occurred are stored in memory for 24 hours.
- At synoptic hour (00, 06, 12, and 18 UTC) reporting times, the current 6-hour maximum and minimum ambient temperatures are computed from the hourly maximum and minimum ambient temperatures in tenths of degrees Celsius, and included as remarks ("1s_nT_xT_xT_x" for maximum temperature, and "2s_nT_nT_nT_n" for minimum temperature) in the current synoptic hourly METAR.
- The current 12-hour average ambient temperature is also computed once each minute from the current and previous 12-hour reported 5-minute average temperature (this value is used for calculating current sea-level pressure).
- Once each hour (at the hourly METAR report time) the current hourly ambient temperature and dew point temperature are reported in the METAR Remarks section, to the nearest tenth of a degree Celsius, in the form "Ts_nT'T'T's_nT'dT'dT'd"
- Once each minute, ASOS computes the highest and lowest ambient temperatures, so far for the current calendar day, in tenths of degrees Celsius. The calendar day maximum and minimum ambient temperatures are reported in the midnight, LST hourly METAR remarks (4s_nT_xT_xT_xs_nT_nT_nT_n), and are stored in memory for 31 days as part of the Daily Summary Product. The "midnight, LST hourly METAR" is usually transmitted before 23:59 LST. Therefore, there may occasionally be a discrepancy between the maximum and minimum temperatures reported in the "4" group and the daily maximum and minimum temperatures reported in the ASOS Daily Summary Message (DSM) which runs from 00:00 to 23:59 LST (see Section 5.6 for details).

- Once each day (at 23:59 LST), the highest and lowest ambient temperatures for the current month, along with the date(s) of occurrence, are computed and stored in memory until the end of the following month. On the first day of the following month, ASOS outputs the Monthly Maximum Temperature and date(s) of occurrence, plus the Monthly Minimum Temperature and date(s) of occurrence⁷

Additional temperature parameters are derived from the Calendar Day and Monthly Maximum and Minimum Temperature data. These data may be reported in the daily and/or monthly summary messages, as appropriate.

The daily data include: calendar day average ambient temperature, the latest daytime maximum temperature (LDT), the latest nighttime minimum temperature (LNT), departure of calendar day average ambient temperature from normal, and heating degree days (HDD) or cooling degree days (CDD).

The monthly data include: average monthly temperature, average monthly maximum and minimum temperature, number of days maximum temperature exceeded a set maximum temperature threshold (90°F in the 48 contiguous United States and Hawaii, and 70°F in Alaska), number of days maximum temperature ≤ 32°F, number of days minimum temperature ≤ 32°F, number of days minimum temperature ≤ 0°F, monthly heating degree days, and monthly cooling degree days.

Relative humidity is calculated using the 5-minute average ambient (dry-bulb) temperature and dew point temperature. The 5-minute average temperature is also used to process other algorithms, specifically sky condition (obscuration determination), present weather (freezing rain determination, and snow - rain discrimination), obscurations (freezing fog, fog, mist, haze discrimination), and pressure (sea-level pressure, pressure altitude, and density altitude calculation).

3.1.3 Ambient Temperature/ Dew Point Temperature Strengths and Limitations

Although the methodology of determining the ambient temperature and dew point temperature is not new, substantial improvements have been achieved by ASOS in measuring temperature and dew point by increasing the

⁷These data are contained in the Monthly Summary message issued by ASOS.

sensor aspiration and siting the sensors away from buildings and heat islands. Furthermore, ASOS's continuous monitoring, self-diagnostics, and application of quality control algorithms ensure that any ambient temperature/dew point temperature degradation trend is reported before sensor performance falls below performance standards.

At times, however, the reported dew point temperature may become stuck at around zero degrees Celsius. At other times, it may not be representative because of excessive mirror contamination due to dust or other atmospheric aerosols. An aggressive preventative maintenance program is conducted that includes periodic cleaning of the mirror surface. Furthermore, a planned product improvement effort is underway to find a more reliable alternative for measuring Dew Point temperature (see Section 7.2.2 for details).

3.2 Wind

The rotating cup anemometer and the simple wind vane are the principal indicators of wind speed and direction. Until the mid 1940s, the electrical contacting anemometer was the standard wind measuring instrument. Since then, the "F420" series of instruments have become the standard for wind measurement in the U.S. A basic system of this series consists of a cup-driven Direct Current (DC) generator with an output calibrated in knots and a vane coupled to an indicator by means of a DC synchro-system. The ASOS uses a modern automated version of the F420, in which electro-magnetic signals generated by the rotating cup and wind vane are directly converted into reportable values by ASOS.

Before ASOS, airport wind sensors were generally exposed 20 feet above ground level. With modern, high-performance aircraft, this standard no longer applies. Now, current federal standards for siting meteorological equipment specify (with some variance permitted) a height of 10 meters (32.8 feet). Typical ASOS wind sensor heights are 33 feet or 27 feet, depending on local site-specific restrictions or requirements. Figure 6 shows the ASOS anemometer. The ASOS will report the following wind related parameters.

Wind Direction: ASOS reports a 2-minute average of 5-second average wind directions once a minute (i.e., 24 samples each minute) for distribution through the OMO and computer-generated voice messages. The current 2-minute average wind direction is updated on selected OID screen displays once every minute and included in the transmitted METAR/SPECI messages. The direction from which the wind is blowing is reported to the nearest 10 degree increment (e.g., 274 degrees is reported as 270 de-



Figure 6. ASOS Anemometer

grees). Wind direction is reported relative to *true north* in the METAR/SPECI message, in the daily/monthly summaries, and on all video displays. Wind direction is reported relative to *magnetic north* in the computer-generated voice messages, and on the OID "AUX" data display screen. See section 3.2.2.1 for details.

Wind Speed: A 2-minute average is updated once every 5 seconds and is reported once every minute in the OMO and computer-generated voice messages, and included in the METAR/SPECI message and various OID screen displays. See Section 3.2.2.1 for details.

Wind Gust: This is a basic component of wind character and is updated every 5 seconds. It is appended to and reported with the basic wind observation only when appropriate conditions for reporting wind gust exist (see definition in Section 3.2.2.2). Wind gust information is included in the current OMO, computer-generated voice messages, the METAR/SPECI, and OID displays.

Wind Shift: This remark is reported in the OMO and the METAR/SPECI when appropriate. See Section 3.2.2.2a for details.

Variable Wind Direction: This data element is reported in the OMO and the METAR/SPECI when appropriate. See Section 3.2.2.2b for details.

Table 2. Wind Sensor—Range, Accuracy, Resolution

Parameter	Range	Accuracy	Resolution
Wind Speed	0 to 125 knots	± 2 knots - or - 5% (whichever is greater)	1 knot
Wind Direction	0 to 359 degrees	± 5 degrees when wind speed is ≥ 5 knots	nearest degree

Squall: Although squall is a basic component of wind character and, under appropriate conditions is updated every 5 seconds, it is reported in the *present weather* section of the METAR/SPECI observation; direction and speed values are indicated in the wind group. See Section 3.2.2.2c for details.

Peak Wind: This remark is reported in the scheduled hourly METAR, as appropriate. It is the greatest 5-second average wind exceeding 25 knots which has been observed since the previously scheduled hourly METAR.

Daily Peak Wind: This value is reported in the Daily Summary message (see Section 5.6.1). It is the greatest 5-second average wind speed observed (converted to miles per hour) during the 24-hour calendar day beginning at 5-seconds past midnight, Local Standard Time (LST), (00:00:05 LST) and ending at midnight (00:00:00 LST) the next day.

Fastest 2-Minute Wind: This value is reported in the Daily Summary message. It is the fastest 2-minute average wind speed (in miles per hour) observed over the 24-hour calendar day.

3.2.1 Wind Sensor

The ASOS wind sensor (Figure 6) employs a “light chopper,” electro-optical method to determine wind speed and convert it to appropriate electro-magnetic signals. Wind sensor measurements conform to the Range, Accuracy, Resolution specifications described in Table 2. In addition, the sensor’s starting threshold for response to wind direction and wind speed is 2 knots. Winds measured at 2-knots or less are reported as calm.

3.2.2 Wind Algorithm

The basic method of observing wind direction and speed is to take a fixed point, time averaged measurement. The ASOS algorithm uses a 2-minute period to obtain the current average wind direction and speed. In both cases, ASOS obtains the wind character (i.e., gusts and present weather squalls) and the peak wind by comparing the difference between the average wind speed with the maximum “instantaneous” wind speed observed over a specified time interval. When this difference exceeds a prescribed value, the appropriate additional wind information is included in the observation. The ASOS wind shift remark is determined from the difference between the current 10-minute average (of 2-minute average winds) and the 10-minute average (of 2-minute average winds) from 15 minutes ago, provided the intervening 2-minute average wind speeds are greater than 9 knots. Within ASOS, all average wind directions and speeds are rounded up to the nearest degree and knot, respectively.

3.2.2.1 Wind Direction and Speed

In the past, observers monitored an analog or digital wind dial over a short period to determine the average wind direction and speed for the observation. Most sites also had a wind recorder device to provide a continuous documented record of measured wind direction and speed. The observer often used this device to determine the maximum instantaneous wind speed over the 10-minute period before completing the observation. The observer used visual/mental averaging and ultimate human judgement to create an observation of wind. This method was not always consistent from site to site or from one observer to another.

ASOS continuously and objectively measures wind direction and speed once every second, far more frequently, consistently, and accurately than an observer could. Every

ASOS processes data identically, which provides site-to-site consistency unknown in past records. Five-second wind direction and wind speed averages are computed from the 1-second measurements. These 5-second averages are rounded to the nearest degree and nearest knot and are retained for 2 minutes. These five-second averages are the fundamental units used to compute reportable wind values and are, in effect, the ASOS equivalent to the manual "instantaneous" wind observation.

Every 5 seconds a running 2-minute average wind (direction and speed) is computed and used to further compute wind character. If the computed 2-minute average wind speed is 2 knots or less, the 2-minute average wind direction and speed is reported as "calm" (0000KT).

Once each minute the current 2-minute average wind is stored in memory for 12 hours and made available for reporting in the OMO, the computer generated voice messages (i.e., the ground-to-air radio and telephone dial-in message), the METAR/SPECI reports, and OID displays.

3.2.2.2 Wind Character

Wind Character information is added to the METAR after the Wind Direction and Speed data when the variability in the steady state wind exceeds threshold criteria. Wind Character components include Wind Gusts and Variable Wind. Although Wind Squalls are reported as a Present Weather phenomena in METAR, they are also discussed here for comparison and contrast.

Both the manual procedure and the ASOS algorithm determine Wind Character by examining the maximum "instantaneous" wind speed over the 10-minute period immediately preceding the observation. The manual procedure requires a visual examination and interpretation of the dial readings or recorder to determine "instantaneous" wind speed. The ASOS algorithm, by contrast, relies on objective 5-second averages of 1-second wind measurements.

3.2.2.2a Gusts

In the **manual procedure**, a gust is reported when an observer sees rapid fluctuations in sensor wind speed indications with a variation of 10 knots or more between peaks and lulls during the 10-minutes before the observation. The reported gust is taken from the maximum "instantaneous" wind speed observed during this period. The average 2-minute wind is used to report wind direction and wind speed. Conceivably, an average 2-minute wind speed as low as 3 knots (observed in the last minute) may be reported with a gust of 10 knots (observed in the last 10 min-

utes). Observations of 5 knots with gusts of 10 to 15 knots, however, are the more common minimum values reported.

The **ASOS algorithm** also relies on a 10-minute observation period to determine gusts, but uses it in a different way. Once every 5 seconds, the ASOS computes the greatest 5-second average wind speed (and corresponding direction) during the past minute, and once each minute stores this information in memory for 12 hours.

Once every 5 seconds the ASOS computes the current 2-minute average wind speed and compares it with the greatest 5-second average wind speed during the past minute. If the current 2-minute average wind speed is equal to or greater than 9 knots and the greatest 5-second average wind speed (during the past minute) exceeds the current 2-minute average speed by 5-knots or more, then the greatest 5-second average speed observed during the past minute is stored in memory as a gust for 10 minutes.

Once every 5 seconds, the ASOS compares the highest gust stored in memory for the past 10 minutes with the current 2-minute average wind speed. If the difference between the two is 3 knots or more, the current reported wind speed is greater than 2 knots, and the highest gust exceeds the minimum 5-second wind speed in the past 10 minutes by 10 knots or more, then the highest gust stored in memory is designated as the reportable gust. This value is appended to the current wind direction and speed reported in the OMO, computer-generated voice messages, and the METAR/SPECI reports. The minimum gust speed reported by ASOS is 14 knots. Wind speeds from 3 knots and 11 knots may be reported with gusts to 14 knots. For example, a 2-minute average wind of 240 degrees at 10 knots with gusts to 20 knots is reported as: "24010G20KT."

3.2.2.2b Variable Wind

Both the manual procedure and the ASOS algorithm use the same definition for determining a variable wind but use different methods for reporting it. In both cases, a variable wind is reported when the wind direction varies by 60 degrees or more during the 2-minute evaluation period before the observation. If the 2-minute wind speed is 6 knots or less, then a variable wind direction indicator (VRB) is included in the basic wind group; if the 2-minute wind speed is greater than 6 knots, then a variable wind direction group is appended to the basic wind group in the body of the METAR/SPECI report.

The basis for the manual determination of a variable wind is simply a visual interpretation of the wind instrument reading during the 2-minute evaluation period. The ASOS algorithm by contrast compares the range of 5-sec-

ond average wind directions during the past 2 minutes (24 samples).

In either case, if the current 2-minute average wind speed is 6 knots or less, the wind direction and speed is reported as "VRBff," where "ff" is the current 2-minute average wind speed in knots. For example, a variable wind at 3 knots is encoded as "VRB03."

If the current 2-minute average wind speed is greater than 6 knots, then the current wind direction and speed are placed in the body of the report and followed by a variability indicator in the form "d_nd_nVd_xd_x," where d_nd_n is the minimum, and d_xd_x is the maximum variable wind direction during the past 2-minutes. For example, a current 2-minute wind of 270 degrees at 10 knots that varies from 240 degrees to 300 degrees is coded as: 27010 240V300.

3.2.2.2c Squalls

In the **manual procedure**, observers report a squall when wind speed suddenly increases by at least 16 knots and speed is sustained at 22 knots or more for at least 1 minute. Observers manually determine a squall by visually examining the indicated or recorded "instantaneous" wind speed. The reported squall value is taken from the maximum "instantaneous" wind speed sustained for at least 1 minute. Although squalls are measured as a parameter of wind, they are reported as an element in the present weather field of the METAR/SPECI report.

ASOS algorithm by contrast, computes a potential squall value once every 5 seconds. If the current 2-minute wind speed (measured every five seconds) is greater than or equal to 22 knots and exceeds the 2-minute average wind speed computed two minutes ago by 16-knots or more, then the highest 5-second average wind speed during the last 2-minutes is stored in memory as a squall for 10 minutes. Only the current squall or non-squall default value is stored in memory. The stored squall value is reported as "SQ" in the present weather field if the current 2-minute average wind speed is greater than 2 knots, and if the squall value exceeds the current 2-minute average wind speed by more than 3 knots.

According to this algorithm, a squall may continue to be reported by the ASOS for up to 10 minutes after the squall is written to memory, provided the above minimum wind-speed, squall reporting conditions are met. The minimum wind speed - squall combination reported by ASOS is a wind speed of 3 knots, with a squall of 22 knots.

3.2.2.3 Wind Remarks

The ASOS will include Wind Shift and Peak Wind remarks in the METAR/SPECI reports when appropriate.

3.2.2.3a Wind Shift

Both the manual procedure and the ASOS algorithm use the same definition of a wind shift as described in the FMH-1: "A wind shift is indicated by a change in wind direction of 45 degrees or more in less than 15 minutes with sustained winds of 10 knots or more throughout the wind shift."

The observer relies on his alertness and a visual estimate of the 2-minute average wind to determine the onset of a wind shift. A Frontal Passage (FROPA) remark may be appended to the wind shift remark when the wind shift is associated with a frontal passage. This determination of course is based on human judgement.

The ASOS, on the other hand, determines a wind shift by first making sure that minimum wind speed and direction change criteria are met. These checks are made to ensure that light, variable winds are not erroneously reported as a wind shift.

The wind *speed* criterion requires that all 2-minute average wind speeds computed each minute over the past 15 minutes are greater than 9 knots. If this criterion is met, then the current 10-minute average wind *direction* derived from ten one-minute-observations is compared to a similar 10-minute average wind direction from 15 minutes ago. If the wind directions differ by 45 degrees or more, then a wind shift is encoded.

The wind shift remark generated by the ASOS in the METAR report is: "WSHFT hhmm," where "hhmm" is the Universal Coordinated Time (UTC) of when the shift began (15 minutes ago). Once the wind shift remark is reported, it will continue to be included in all subsequent reports (including long-line dissemination of ASOS generated SPECI) through the next scheduled hourly METAR. The ASOS, of course, is unaware of distant phenomena and synoptic scale weather patterns and consequently cannot confidently determine if a frontal passage (FROPA) remark should be appended to the wind shift remark. Therefore, FROPA is not reported by ASOS. At attended sites however, this remark may be added by the Observer in accordance with agency reporting policy.

3.2.2.3b Peak Wind

The Peak Wind, by definition, is the highest instantaneous wind speed observed or recorded since the last scheduled hourly observation (METAR). The Peak Wind direction, speed and time of occurrence are reported in METAR remarks as: "PK WND dddff(f)/(hh)mm," where ddd = direction (true) in tens of degrees, ff(f) = wind speed in knots, and (hh)mm = (hour) minutes past current hour of most recent occurrence of the reported peak wind. The "hh" indicator is included only when the peak wind occurred in the previous hour since the last METAR.

The manual procedure requires a Peak Wind to be reported when the maximum *instantaneous* wind speed since the last METAR exceeds 25 knots.

In ASOS, the Peak Wind is determined from the highest observed 5-second average wind speed which exceeds 25 knots since the last generated METAR, whether transmitted or not (FIBI).

3.2.3 Wind Strengths and Limitations

The major strength of the ASOS in reporting winds is the consistency of measurements. While Observers rely on perception and human judgement to interpret wind instruments, automated systems rely on digital second-by-second measurements that are processed identically from time-to-time and place-to-place.

One limitation in the automated observation is a lag in reporting wind shifts (in METAR remarks). The wind shift algorithm cannot rely on external clues used by the observer (like thunder or snow showers) for early collateral assurance of a wind shift - frontal passage occurrence. It must therefore wait the full 15-minutes required in the definition of wind shift before outputting a remark. Although highly unlikely, a wind shift and variable wind remark may both be generated and included on the same METAR under conditions of light and variable winds which just barely meet the wind shift reporting criteria, or when a FROPA has occurred in the preceding 10-15 minutes. To be more responsive to operational needs, the wind reporting algorithm has been tuned to prevent excessive, frequent reporting of a wind shift once a report is issued and when a variable wind condition exists.

3.3 Pressure

Atmospheric pressure is the most important surface weather element for aircraft operations since it provides the means of establishing the height of an aircraft above

the ground. It is the only element that cannot be directly observed or qualitatively sensed by the observer or pilot. As a result, pressure has always been carefully measured and the operational sensor routinely compared to some reference standard.

All the currently computed pressure elements will continue to be reported by the ASOS with the same or higher level of precision as the human report. The pressure parameters available from ASOS are:

- Sensor Pressure
- Altimeter Setting
- Pressure Remarks
- Sea-Level Pressure
- Density Altitude
- Pressure Altitude
- Pressure Change/Tendency
- Station Pressure

Because accurate pressure is critical, three separate and independent pressure sensors are used at towered airport locations. At other locations, two pressure sensors are used. The ASOS algorithm compares the pressure sensors' readings and issues a pressure report only when there is acceptable agreement between at least two sensors.

3.3.1 Pressure Sensor

The ASOS pressure measurement instrument consists of redundant digital pressure transducers, which use capacitive sensors, one side of which is permanently evacuated to a vacuum to make it a barometric pressure sensor. Advanced microcomputer electronics and sophisticated firmware provide reliable performance. The barometers are located on a tray at the bottom of the ACU and are exposed to the ambient air pressure. In cases when the ACU is installed in pressurized buildings, this exposure is through a port connected to an outside static pressure vent. Figure 7 shows the pressure sensors in the ACU. The specified operational characteristics for these sensors are:

- Range: 16.9 - 31.5 inches of mercury
- Accuracy: ± 0.02 inches of mercury
- Resolution: 0.003 inches of mercury (measurement);
0.005 inches of mercury (reporting)

3.3.2 Pressure Algorithm

A sophisticated algorithm routinely computes and updates the pressure report for each pressure sensor once a minute from readings obtained every 10 seconds from each

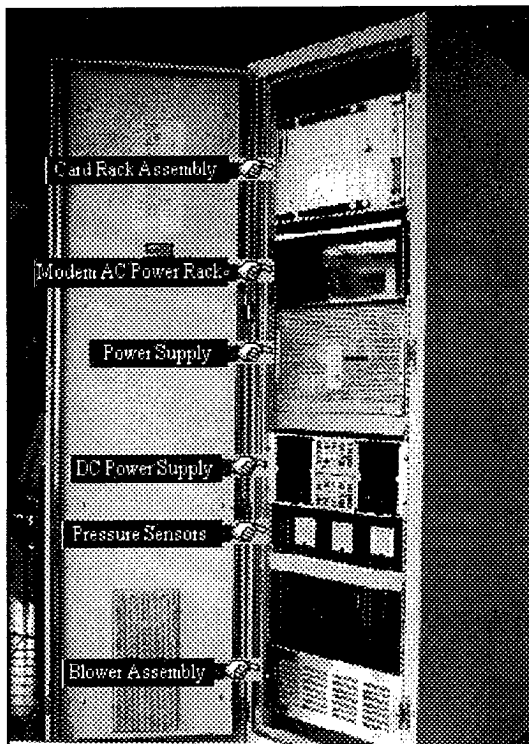

Figure 7. ASOS Pressure Sensor

sensor. If one or more of the 6 pressure readings obtained from each sensor in the past minute is missing, then the 1-minute pressure value for that sensor is marked as "missing" and the sensor is logged as "inoperative." The current 1-minute pressure values from each sensor are then compared against each other and absolute differences computed. The lowest 1-minute sensor pressure value obtained from a pair of sensors, whose pressure difference is 0.04 inch or less, is the designated ASOS pressure to be reported at the end of the minute. This pressure value is then used to compute an altimeter setting and other derived pressure values.

A sensor whose 1-minute sensor value differs by more than 0.04 inch from another operational sensor is automatically logged as "inoperative" and the sensor pressure value set to "missing." This will cause a maintenance check indicator to be appended to all subsequent ASOS METAR/SPECI reports until the sensor is returned to an "operational" status. Once a pressure sensor is logged as inoperative, it can only be returned to an "operational" status by a maintenance technician. If one of the sensors (at two-sensor locations), or if two of the sensors (at three-sensor locations) are logged as "inoperative," then the designated ASOS pressure elements are all omitted in the METAR/SPECI reports.

3.3.3 Pressure Strengths and Limitations

The pressure sensors are the most reliable and accurate sensor in ASOS. The only limitation (if one can call it that) is that pressure remarks will be reported more often in ASOS METAR messages than in manual METAR messages simply because of the continuous weather watch which ASOS provides.

3.4 Precipitation Accumulation

Accurate liquid-equivalent precipitation accumulation measurements are essential for hydrological, flood forecasting, and agriculture applications. For aviation purposes, freezing or frozen precipitation accumulation measurements provide a quantitative dimension to the qualitative detection and reporting of freezing or frozen precipitation by other ASOS sensors.

Basic manual measurements of precipitation accumulation in the U.S. have traditionally relied on the Standard 8-inch Gauge. This consists of an 8-inch cylinder with an inverted funnel orifice leading to a graduated inner cylinder at the base of the funnel neck. The inner cylinder is used to measure liquid precipitation accumulation. When freezing or frozen precipitation is expected or is occurring, the funnel and inner cylinder are removed. Frozen precipitation captured in the outer cylinder are periodically melted indoors to measure the liquid-equivalent of frozen precipitation (LEFP).

In the early development of an automated precipitation accumulation gauge, it was recognized that automated measurement of liquid and LEFP each presented a unique challenge, so, a separate specification was written for each type of precipitation. The automated Heated Tipping Bucket (HTB) technology from the 1970s was adopted and modified to meet these needs. Over the years, many improvements were made and incorporated into ASOS. Early versions of the heated gauge applied excessive heat creating excessive evaporation and the under-reporting of the liquid-equivalent mass.

The current version of the HTB gauge applies less heat over a longer heating cycle, thus yielding a more accurate mass measurement of frozen precipitation. Changes in the tipping bucket inner design also have improved overall performance in liquid precipitation events. These improvements have resulted in the ASOS HTB becoming a very capable liquid precipitation accumulation gauge in all but the most extreme heavy rainfall events. However, some

deficiencies still remain in its ability to fully measure precipitation accumulation during the cold-season LEFP events. Consequently, the ASOS HTB is primarily used to measure liquid accumulation. Alternative solutions are being pursued to provide LEFP information. These solutions include: (1) Provision of separate LEFP reports through existing manual supplementary observing networks from event-driven Supplementary Data Observations and schedule-driven Supplementary Climate Data reports, and (2) Development of a follow-on All-Weather Precipitation Accumulation Gauge for ASOS (see Section 7.2.4).

3.4.1 Heated Tipping Bucket (HTB) Precipitation Gauge

The ASOS HTB shown in Figure 8 consists of 6 main components:



Figure 8. ASOS Heated Tipping Bucket

- A wind shield that surrounds the HTB and protects it against blowing snow from falling into the HTB collector funnel (the wind shield is installed on the ASOS HTB in climates where the snowfall is $\geq 20\%$ of the annual precipitation accumulation)
- A 12-inch diameter collector funnel
- A pivoting dual chamber tipping bucket. This bucket tips when one chamber is filled with 0.01 inch of liquid precipitation, thus emptying the contents into a drain pan and exposing the other chamber to the precipitation gathered by the collector funnel
- An electronic switch which counts the number of tips per minute
- A drain pan and a drain tube
- Heating elements to prevent freeze-up during cold weather.

The HTB has 2 heating elements. One heating element is wrapped around the underside of the collector funnel, and the other around the drain tube. Each heater is separately thermostatically controlled to maintain a temperature of 40°F. A master thermostat regulates electric power to both heating elements. Power is turned on when the temperature falls below 40°F and is turned off when the temperature falls below -20°F. Power is not turned on again until the temperature rises above -12°F. Power is turned off when the temperature is at or above 40°F.

The HTB has a precipitation accumulation range of 0 to 10.00 inches per hour, a resolution of 0.01 inch (i.e., one tip) and an accuracy of ± 0.02 inch or 4% of the hourly total (whichever is greater).

3.4.2 Precipitation Accumulation Algorithm

The precipitation accumulation algorithm obtains precipitation accumulation data from the HTB precipitation gauge once each minute. These data are valid for discrete 60-second periods ending at M+00. The ASOS algorithm corrects the tipping bucket measurement, particularly during periods of high rainfall rates. Each minute the measured rainfall is adjusted using the following equation:

$$C = A (1 + .60A)$$

In this equation, C = the calculated rainfall amount and A = the measured amount from the tipping bucket. All calculations are performed internally using floating point until rounded for final output each minute.

If a 1-minute precipitation accumulation output is missing and the precipitation identifier sensor (discussed in Section 4.3) is either inoperative or concurrently reports precipitation, then the associated METAR precipitation remarks/messages will either be omitted (Prrrr remark is deleted), or contain a "/" (e.g., 6////, 7////). Furthermore, when the precipitation accumulation sensor is inoperative, a "PNO" remark will be appended to the METAR to indicate that precipitation accumulation information is not available. In SHEF, missing precipitation accumulation data will be reported as "M" in place of the missing value. When available, the output data are used each minute by the algorithm to compile a variety of cumulative precipitation remarks/messages. These include:

METAR hourly message, "Prrrr" remark: In this message "rrrr" is the liquid equivalent of all precipitation (in hundredths of an inch) which has occurred since computation of the Prrrr remark for the last scheduled hourly

METAR message. The "rrrr" is the sum of all 1-minute precipitation accumulations calculated during this period. If any of the required constituent 1-minute precipitation accumulation calculations are missing, the remark is omitted and "PNO" is appended to the remarks section. If no precipitation has occurred since the last scheduled hourly METAR, the Prrrr remark will not be reported. If only a trace of precipitation has occurred, the Prrrr remark will report "P0000."

METAR 3- and 6-hourly report, "6RRRR" precipitation accumulation remark: "RRRR" is the amount of precipitation, in hundredths of an inch, which has accumulated in the past 3- or 6-hours. Three-hourly amounts are reported in the 03, 09, 15, and 21 UTC METAR reports. Six-hourly amounts are reported in the 00, 06, 12, and 18 UTC METAR reports.

If any of the constituent hourly Prrrr remarks are missing, the 6RRRR remark is encoded as 6////.

METAR 24-Hour "7RRRR" precipitation accumulation remark: "RRRR" in this message is the amount of liquid equivalent in hundredths of an inch accumulated over the last 24-hours. This remark is reported with the 1200 UTC METAR provided there has been at least 0.01 inch of precipitation in the past 24-hours (i.e., since the last 1200 UTC METAR). The precipitation accumulation reported in the 7RRRR remarks is compiled from the hourly precipitation computations. If any hourly amount is missing during the 24-hour period, the 7RRRR remark is encoded as 7////.

SHEF 15-Minute Precipitation Criteria message: These messages are generated when the current 15-minute period accumulation exceeds the locally established precipitation accumulation onset threshold and will cease when the accumulation for the current interval falls below the termination threshold. The precipitation accumulations for the four most recent discrete 15-minute periods (ending at H+00, H+15, H+30 and H+45) are chronologically listed in these messages.

These messages are issued in ".E" SHEF message format, and are initially disseminated through the NWS or the FAA communications networks to the NWS Telecommunications Gateway (NWSTG) and the System Monitoring and Coordination Center (SMCC) where they are made available for redistribution to NWS offices and compilation on the daily Service Records Retention System (SRRS) tape for the National Climatic Data Center (NCDC). These

messages are identified within the NWS by their RR6 AFOS/AWIPS header: "CCCR6XXX," where "CCC" is the originating AFOS node, "RR6" is the designation for SHEF 15-minute messages originating from ASOS and "XXX" is the ASOS location identifier (see Section 5.5.1 for details).

All SHEF data from FAA sites are contained in a "collective" (a group of individual messages bundled together) and are identified by the collective header "NMCRR7NKA." The precipitation accumulation for each 15-minute period is derived from the sum of the 1-minute precipitation accumulation calculations within each discrete 15-minute period. If any of the constituent 1-minute precipitation accumulation calculations are missing, the value encoded in the SHEF 15-minute precipitation criteria message for the entire 15-minute period is "M."

SHEF Hourly Routine Precipitation message: The precipitation accumulation period for this message is 60 minutes. The end time (in minutes past the hour) is set at H+00. These messages are issued once an hour at the time specified to support calibration of the precipitation processing at the designated WSR-88D Radar Product Generator.

These SHEF messages contain an hourly precipitation accumulation. They are issued in ".A" SHEF message format and are made available and distributed in the same manner as the SHEF 15-Minute Precipitation Criteria messages. The messages are identified within the NWS by their RR7 AFOS/AWIPS header: "CCCR7XXX." All SHEF data from FAA sites are contained in a collective and are identified by the collective header "NMCRR7NKA." These messages are further distinguished from the 15-Minute Precipitation Criteria messages by message type identification within the body of the message (see Section 5.5.2 for further details).

The SHEF Hourly Routine Precipitation accumulation is derived from the sum of the 1-minute precipitation accumulation calculations during the latest discrete 60-minute period. If any of the constituent 1-minute precipitation accumulation calculations are missing, the SHEF Hourly Precipitation message will report the precipitation accumulation as "PPH M" (see Section 5.5.2).

Daily and Monthly cumulative precipitation totals: These precipitation totals are summed each minute and included along with other data in the Daily Summary and Monthly Summary Products/messages.

The information in the Daily Summary is valid for the 24-hour period beginning at 00:00 LST and ending at 23:59 LST. This message is issued on the following calendar day at programmable transmission times (see Section 5.6 for further details).

The Monthly Summary message is valid for the calendar month. This message is issued on the first day of the following month at a time specified by the system manager. The Monthly Summary message contains the amount(s) and date(s) of the maximum 24-hour precipitation accumulation during the calendar month; the number of calendar days with precipitation equal to or greater than 0.01, 0.10, 0.50 and 1.00 inches respectively; and departure of monthly cumulative precipitation totals from normal. Other parameters are also included in the Daily and Monthly Summary messages. See Sections 5.6.1 and 5.6.2 for further details.

3.4.3 Precipitation Accumulation Strengths and Limitations

There are well known problems (referenced in Section 3.4) associated with a HTB precipitation gauge. A major problem occurs during high rainfall rate events when the tipping bucket cannot keep up with the water flow and under-reports the accumulation. The ASOS software corrects for the HTB bias to under report precipitation accumulation during most heavy rainfall events (greater than 1.80 inch per hour); however, during extremely heavy rainfall events (greater than 10 inches per hour), the HTB may still under-report the total rainfall accumulation.

During freezing conditions, the application of heat to melt snow and prevent gauge icing also induces evaporation or sublimation, especially during light freezing rain or snow events at temperatures near 32°F. This results in a tendency to under-report freezing or frozen precipitation accumulation.

The tendency to under-report accumulation during freezing rain or snow events is moderated by using a less intense heat source to melt the frozen precipitation from the tipping bucket at a slower rate. The slower heating rate however, can sometimes allow unmelted snow to bridge over the heated funnel surface and form a snow cap over the orifice opening which prevents any further accretion into the gauge.

At some time after the precipitation event ends, under bright sunshine and/or warming ambient temperature, the snow cap melts and falls into the gauge. This causes a delayed accumulation to be registered and falsely reported at a time when no precipitation is occurring. "False tips" may also be caused by dew, frost, or heavy fog.

CHAPTER FOUR

4.0 Automating the Subjective Weather Elements

While automating most objective weather elements is fairly straightforward, there are numerous complexities in automating subjective visual elements such as sky condition, visibility, and present weather. The major problem is how to objectively quantify subjective human judgement.

With subjective elements, observers traditionally read instruments and watch weather conditions in their area at a fixed time to produce a “snap-shot” observation—a method called spatial averaging. To create a similar observation, automated systems repetitively sample conditions in a relatively small volume of air and then average these data over a set time period—a technique called time averaging. Technological advances have made it possible for modern observations to progress from the periodic, subjective, spatial averaging methodology of the observer to an objective, nearly continuous, temporal averaging method of automated observing systems.

The rules for observing sky condition (clouds), visibility, present weather, and obscurations were designed for observers and are still defined for subjective use; however, the FMH-1 now includes expanded rules for automated techniques. Because of the complexity of the subjective weather elements, separate sections are devoted to sky condition, visibility, and present weather. Each section discusses the differences between manual and automated rules and techniques.

4.1 Automating Sky Condition

Observers have used rotating beam ceilometers (RBC) and the newer laser beam ceilometers (LBC) for years to measure the height of clouds. Visual estimates were still needed to determine the amount of clouds. The challenge of automating the data from such sensors was not only to process the height accurately, but also to provide a representative description of the amount of cloud coverage. Because the atmosphere is normally in motion, it was found that processing the ceilometer signal through a sophisticated algorithm over a 30-minute time period provided an optimally representative and responsive observation similar to that depicted by an observer. To be sensitive to the latest changes in sky conditions, the most recent 10 minutes of the data are processed twice (double-weighted). To be most responsive to operational needs, the

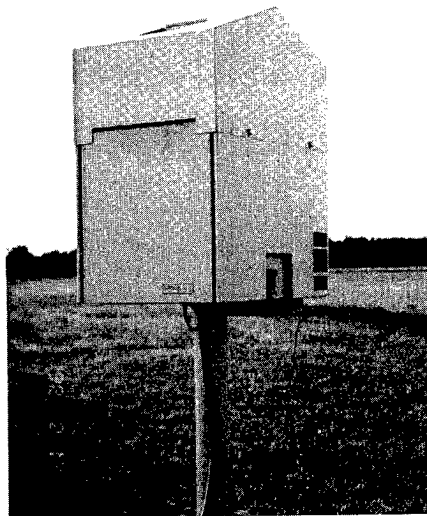

Figure 9. Laser Beam Ceilometer

ASOS ceilometer is located near the touchdown zone of the primary instrument runway at most airports. At large airports, a secondary Cloud Height Indicator (CHI) may be located elsewhere on the airport to provide additional information when there is a meteorological discontinuity. At small airports the ceilometer may be collocated with other sensors near a center-field location or touchdown zone, depending on local siting requirements.

4.1.1 Cloud Height Indicator Sensor

The ASOS uses a laser beam ceilometer with a vertical measuring range of 12,600 feet and reporting range of 12,000 feet (Figure 9). The ASOS cloud sensor, or CHI, is a vertically pointed laser transmitter and receiver. Its operation is similar to radar in that the time interval between pulse transmission and reflected reception from a cloud base is used to determine the cloud height. Sophisticated time-averaging algorithms in the ACU are also used to interpret “cloud hit” information from the CHI and determine cloud height and amount.

The CHI consists of a gallium arsenide laser beam ceilometer operating in the near Infrared (IR) portion of the electro-magnetic spectrum at a wavelength of about a 0.9 microns. The instrument employs Light Detection and Ranging (LIDAR) principles and computer algorithms to provide cloud coverage and height information. The noise inherent in the return signal varies with ambient tempera-

ture. To optimize the laser's signal-to-noise performance, the CHI's pulse frequency varies with the ambient temperature. The frequency range is 620 Hertz (Hz) to 1,120 Hz with a nominal pulse frequency of 770 Hz at room temperature (68 °F). The frequency is also modulated by the age of the equipment to maintain a constant power output. The width of the beam is confined to a divergence of ± 2.5 milliradians (mrad) so that at 12,000 feet the beam's sample area is a circle with a diameter of 60 feet.

The CHI reports will contain only opaque clouds. Moisture layers, or thin clouds detected by the CHI and considered too thin to be a cloud, will be reported as a restriction to vertical visibility or simply not reported. The reporting of vertical visibility is dependent on the thickness and density of the moisture layer. To correctly classify these signals received by the ceilometer, sensor software processes the data into three categories: "no hit," "cloud hit," and "unknown hit."

The signal signature of a cloud return or "cloud hit" is characterized by a rapid increase in backscatter when the beam passes from the clear air beneath the cloud into the moist conditions within the cloud. Figure 10 is an example of a "cloud hit" at 4,500 feet. At the end of each 12-second sampling, the CHI produces a detailed, high-resolution back-scatter profile from which a unique determination of the cloud base can be made. The cloud base "hits" (or returns) from each pulse are assigned to one of the 252 50-foot vertical data bins within the 12,600 foot measurement range. This results in a vertical resolution of 50 feet!

Not all signal returns exhibit the sharp signature pattern of a "cloud hit," (as shown in Figure 10). Those signals without sharp returns are classified as "unknown hits." A return from deep fog where the scatter return pattern extends from the surface to around 600 feet is shown in Figure 11. These "unknown hits" are primarily caused by precipitation and fog that mask the base of the clouds. This broadened moisture field returns laser back scatter signals from various heights within the moisture field. Because these signals cannot be processed as a definite cloud return, they are processed as a vertical visibility (VV). VV is defined as the distance in feet a person can see vertically from the surface of the earth into an obscuring phenomena or indefinite ceiling.

All the values of "unknown hits" are processed and stored in height bins reserved for the VV values (separate from the "cloud hit" bins). Finally, all the returns in the VV bins are processed into a single mean height and assigned to a single bin. The VV returns are then processed by the sky condition algorithms to determine cloud cover, cloud height, or VV.

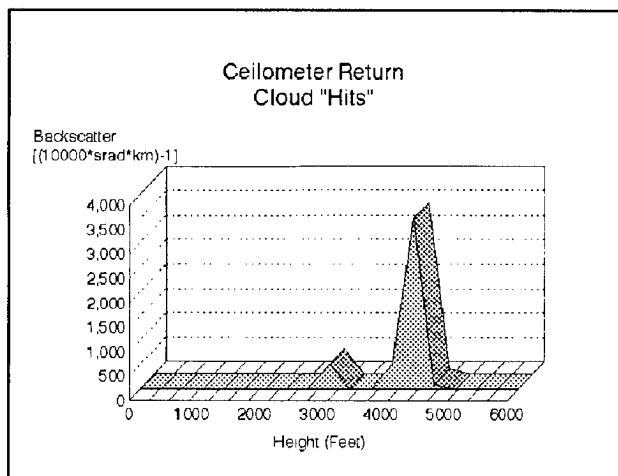

Figure 10. Example Of Cloud "Hit" At 4,500 Feet

4.1.2 Sky Condition Algorithm

Computer algorithms (organized processing steps) are used to process the signal data as described above into sky condition reports that are encoded into METAR and SPECI reports. Describing exactly how the algorithms work is quite complicated, so what follows is a simplified explanation.

Every 30 seconds a sample is compiled from the CHI's back scatter returns taken from the most recent two or three 12-second processing intervals completed within the 30-second period. Each 12-second interval processes more than 9,000 signals for back scatter returns. These data are processed to determine the height of the returns and whether

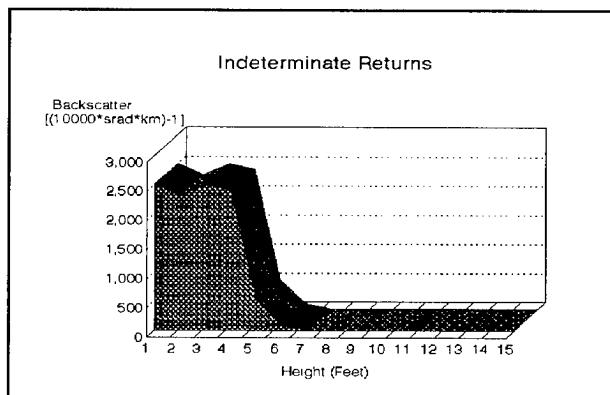

Figure 11. Example Of "Unknown Hit"

the sample compiled from these returns is a "cloud hit" or an "unknown hit." Every minute, ASOS processes the most recent 30 minutes of 30-second sample data; the last 10 minutes of data are processed twice (double weighted) to be more responsive to the latest changes in sky condition. This technique provides a total of 80 samples; 40 in the

first 20 minutes and 40 in the last 10 minutes. The cloud signal hits for the latest 30 minutes are then rounded or "binned" to the nearest 100 feet for cloud heights between the surface and 5,000 feet; to the nearest 200 feet for heights between 5,000 and 10,000 feet; and to the nearest 500 feet for heights above 10,000 feet.

Each minute, if more than five bin height values have been recorded (during the last 30 minutes), the cloud heights are clustered into layers using a least-square statistical procedure until there are only five bins remaining (each bin can have many "hits" in it). These bins, or clusters, are then ordered from lowest to highest height.

Following this clustering, ASOS determines whether the clusters can be combined into "meteorologically significant" height groups. This second clustering is done so that very close layers are not reported (e.g., BKN030 OVC032). At the end of this combining process, all cluster heights between the surface and 5,000 feet are rounded to

Table 3. Cover ASOS Cloud Amount Report —Percent of Sky

ASOS Measured Amount in % of sky cover	Human Equivalent in oktas	ASOS Report
00 to ≤ 05	0	CLR
> 05 to ≤ 25	> 0 to 2/8	FEW
> 25 to ≤ 50	> 2/8 to ≤ 4/8	SCT
> 50 to ≤ 87	> 4/8 to < 8/8	BKN
> 87 to 100	8/8	OVC

the nearest 100 feet. Above 5,000 feet, the algorithm rounds the cluster height values to the nearest reportable value (i.e., nearest 500 ft. up to 10,000 ft. and nearest 1,000 ft. above 10,000 ft.). These bins now are called "layers" and the algorithm will select up to three of these layers to be reported in the METAR/SPECI in accordance with cloud layer reporting priority as specified in FMH-1.

The amount of sky cover is determined by adding the total number of hits in each layer and computing the ratio of those hits to the total possible. If there is more than one layer, the "hits" in the first layer are added to the second (and third) to obtain overall coverage. For reporting purposes, the ASOS measured cloud amount for each layer is then converted to a statistical functional equivalent of a

human observation. All cloud layer heights are reported Above Ground Level (AGL) with respect to field elevation. The cloud amounts reported by ASOS are Clear (CLR) below 12,000 feet, Few (FEW), Scattered (SCT), Broken (BKN), or Overcast (OVC). Table 3 shows the relationship between the ASOS measured cloud amount, the human equivalent, and the reported category.

The sky condition algorithm also tests for total obscurations. Necessary conditions for reporting totally obscured sky include a surface visibility of one mile or less and a high percentage of "unknown hits" at or below 2,000 feet AGL. When these conditions are met, ASOS processes and formats cloud return values classified as "unknown hits" into the sky condition report as "VVaaa." VV is an obscuration; "aaa" represents the visible height in hundreds of feet an observer can see vertically into the obscuring phenomena.

Finally, when a ceiling layer (BKN or OVC) is reported below 3,000 feet AGL, an algorithm tests for conditions requiring a variable ceiling remark. If these conditions exist, ASOS places the entry of CIG minVmax (where min, max is the height in hundreds of feet of the upper and lower limits of the variability) in the remarks section.

4.1.2a Meteorological Discontinuity Sensors

A sky condition algorithm has been developed for use where cloud formation (or advection) typically occurs in (or from) a known location and results in significant concurrent differences in sky conditions over the airport. The meteorological discontinuity algorithm uses output from two CHI sensors. The primary sensor is sited near the touchdown zone of the primary instrument runway. The second CHI is typically sited 2 to 4 miles away from the primary sensor, upwind in the most likely direction of the advection, or closer to the fixed source of the unique sky condition. The second CHI serves to detect operationally significant differences in sky conditions.

Information from the meteorological discontinuity sensor is included in the ASOS METAR under appropriate conditions described below. Data from the primary and meteorological discontinuity sensors are independently processed through the single sensor algorithm and then compared. Only data from the primary sensor is used in the body of the METAR.

Table 4. Criteria For Reporting A Meteorological Discontinuity Ceiling Remark

CEILING REPORTED BY PRIMARY SENSOR	CEILING DIFFERENCE CRITERIA (Primary - Met Discontinuity)
UP TO 1,000 FEET > 1,000 FEET UP TO 3,000 FEET > 3,000 FEET UP TO 5,000 FEET > 5,000 FEET UP TO 8,000 FEET > 8,000 FEET	> 300 FEET > 400 FEET > 600 FEET > 1,000 FEET > 1,600 FEET

If the primary sensor is not operational, the sky condition is not reported, a maintenance check indicator (\$) is appended to the METAR, and no further comparisons are made. If the meteorological discontinuity sensor is not operational, the remark "CHINO LOC" is added to the METAR, where LOC is the nominal location of the meteorological discontinuity sensor (e.g., CF, RWY26L), a maintenance check indicator (\$) is appended to the METAR, and no further comparisons are made.

If both sensors are operational and report a ceiling, and the ceiling reported by the meteorological discontinuity sensor is lower than the ceiling reported by the primary sensor by the difference criteria listed in Table 4, then a remark "CIG VALUE LOC" is included in the METAR where VALUE is the ceiling height (in hundreds of feet) reported by the meteorological discontinuity sensor. For example, if the primary sensor reported a ceiling at 8,000 feet and the meteorological discontinuity sensor reported a ceiling at 6,500 feet on runway 26L then the remark "CIG 065 RWY26L" is reported.

4.1.2b Back-Up Sensors

At some locations, mainly major airports, a back-up CHI may be available. The back-up is generally collocated with the primary sensor suite while the meteorological discontinuity CHI is not. The back-up sensor operates continuously in stand-by mode. When a METAR/SPECI report is created, the ASOS checks for data from the primary CHI sensor. If the primary sensor is inoperative, then ASOS will interrogate the back-up sensor, process that data through single-sensor algorithms, and enter the value into the report. When the primary sensor is back in service, the back-up sensor is once again placed in stand-by mode.

4.1.3 Sky Condition Strengths and Limitations

The ASOS ceilometer is a vertically pointing laser that measures the height and infers the amount of cloud elements that pass over the sensor. It operates continually and once every minute it determines the sky condition for the most recent 30 minutes. The sensor does not measure or know what is happening along the horizon, nor does it report on clouds above 12,000 feet. The horizontal limitation can be partially overcome by using a second meteorological discontinuity CHI sensor at selected major airports where studies have shown that more than one sensor is needed. Due to the inherent motion of the atmosphere however, a single CHI is usually sufficient to report accurate cloud conditions.

A common concern is that the algorithm does not respond fast enough to changes in the sky condition. If a solid cloud deck suddenly appears, the algorithm will report a "FEW" layer within 2 minutes and a "BKN" ceiling layer within 10 minutes. One limitation however is that if the CHI becomes inoperative for three consecutive 30-second readings (1.5 minutes) or misses five or more readings in the most recent 30 minutes, it does not report sky condition. The algorithm requires a full 30-minutes of data from the CHI after restart before a valid sky condition report is once again generated.

Precipitation poses a double challenge. Because the laser can only look vertically, precipitation particles directly overhead will scatter the laser light, often leading to an increased number of "unknown" signal returns. The algorithms described above help distinguish a vertical obscuration caused by falling rain drops from the base of the cloud layer above it. Precipitation can also fall onto or collect on top of the instrument. To limit that problem, a blower is used to move air over the slanted glass cover housing of the laser lens.

Occasionally, the laser CHI can see “too many” clouds. For example, a very sensitive laser will sometimes detect invisible moist layers before they coalesce to become visible clouds. Also, occasional sharp inversions, especially in very cold winter conditions, may trigger the report of clouds. Algorithm developers will continue to work on eliminating these small but annoying traits.

There are times when the CHI may report fewer clouds than the observer. Studies have shown that up to 20 percent of the reports of “FEW” cloud events will be missed by using only one ceilometer. These events are usually widely scattered fair weather cumulus, which the ASOS may report as “CLR.”

What are some of the advantages of ASOS? It will report the onset of low stratus moving over the ceilometer within 2 minutes, and the formation/dissipation of a low ceiling within 10 minutes. If a low cloud layer forms or falls below 1,000 feet AGL, or if the ceiling rises to equal or exceed 1,000 feet AGL, the ASOS will transmit a SPECI report. ASOS will continually monitor the sky condition and automatically create and issue a report with a speed and responsiveness comparable to an observer. The ceilometer does not suffer from night adaptation. Observers must wait for their eyes to adapt to the dark before being able to accurately distinguish night time sky conditions. It is difficult, even for the experienced observer, to distinguish gray on gray when lower stratus cloud layers move in under higher stratus clouds.

Finally, ASOS reports more broken cloud layers and fewer overcast layers than an observer because the ceilometer does not suffer from the “packing effect” (Figure 12). The “packing effect” is a condition where the observer tends to overestimate the cloud coverage because clouds near the horizon appear to blend together or overlap. This effect is due to the curvature of the earth and parallax view of distant objects.

4.2 Automating Surface Visibility

Visibility remains one of the most difficult elements to automate. Sensors can successfully measure atmospheric elements relating to visibility, but it is very difficult to relate these measured elements to the characteristics of human vision. The physical limitations of the human eye and human subjectivity are greatly impacted by precipitation, day and night vision adaptation, contrast, physical obstructions, and perspective.

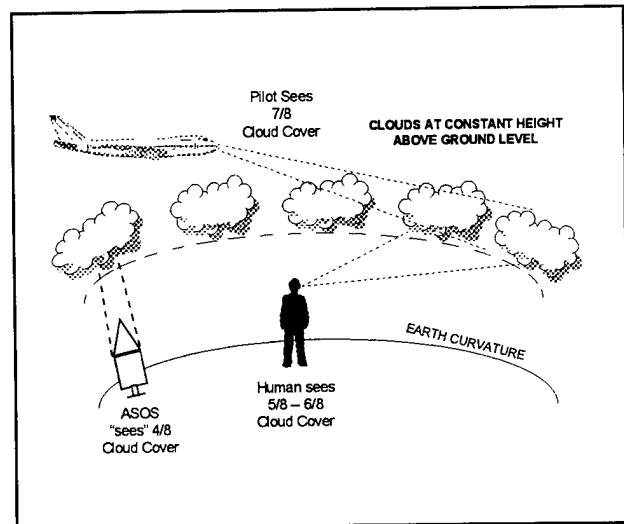

Figure 12. Example of Packing Effect

The value reported as the visibility may reflect only the distance an observer can see due to obstructions such as nearby buildings and trees, not how far the eye can actually see in the absence of such obstructions. It is not unusual to see differing reports of visibility observations under the same conditions because of perspective. The challenge facing observing system developers was to automate visibility reporting to accurately reflect both the meteorological and non-meteorological elements that enter into the human evaluation of visibility.

The NWS and FAA jointly developed the concept of Runway Visual Range (RVR). This concept combined visibility theory with extensive empirical testing of transmissometer measurements to represent the distance a pilot could see runway lights or objects during take off or landing. Thus, it was natural to apply this knowledge in automating the measurement of surface visibility.

The task of automating surface visibility began earnestly in the early 1970s when the FAA and NWS jointly conducted the AV-AWOS experiments. These test demonstrate the feasibility of automated surface observations. By the 1980s, the agencies were able to show that it was practical to automate surface visibility and report a value that was suitable and responsive to the needs of the aviation community. From these tests, a working group in 1981, under the auspices of the Office of the Federal Coordinator for Meteorology (OFCM), produced a set of definitions and guidance for automating sensor derived visibility.

4.2.1 Principles in Visibility Automation

In the early 1970s, NWS scientists developed the concept of Sensor Equivalent Visibility (SEV). SEV was defined as any equivalent of human visibility derived from instrument measurements. This means that visibility is not measured directly but is inferred by measuring other physical characteristics and properties of the air. These properties include the transmittance (or conversely attenuation) of light due to absorption and scattering by atmospheric contaminants such as aerosols, coarse particulates, and hydrometeors. Studies have shown that human visibility is closely correlated with transmittance. A sensor can measure this atmospheric capacity and quantify it through sophisticated algorithms to represent visibility. This is SEV.

Before automating visibility and applying the SEV concept, developers had to create a standard value that could be consistently reproduced in electronic sensors. The fundamental measure of atmospheric clarity, the extinction coefficient, was defined by using the Optec Transmissometer, which measures the attenuation of light by scattering and absorption in the mid-visible light wavelength of 550 nanometers (550 billionths of a meter). It was found that, in general, scattering was the primary cause of attenuation (and therefore visibility reduction). Furthermore, scatter meters were less costly to build and easier to install and maintain than transmissometers. Therefore, qualification testing focused on scatter meters with the goal that they could be used as an alternative to the Transmissometer.

A forward scatter meter was found to correlate better with Transmissometer extinction coefficients and human visibility than a back scatter meter, particularly during snow events. Later testing showed that with slight adjustments in derived visibility based on the type of weather (i.e., rain or snow) a *forward* scatter meter was fully acceptable as a visibility sensor. A visible light source was found to work best with the forward scatter meter because of better agreement with observers during small particle (e.g., haze) events.

The next step was to develop algorithms to process the sensor data into a representative visibility. This step required identifying those key elements the human eye responds to in determining visibility. During the day, the human eye relies on variations in contrast between the visibility target and its background when viewing through fog, mist, haze, rain, or snow. At night, the human eye uses a distant unfocused light to determine visibility. The illuminance threshold, like contrast threshold, assumes that the average observer can see a light source of two mile-candle illuminance.

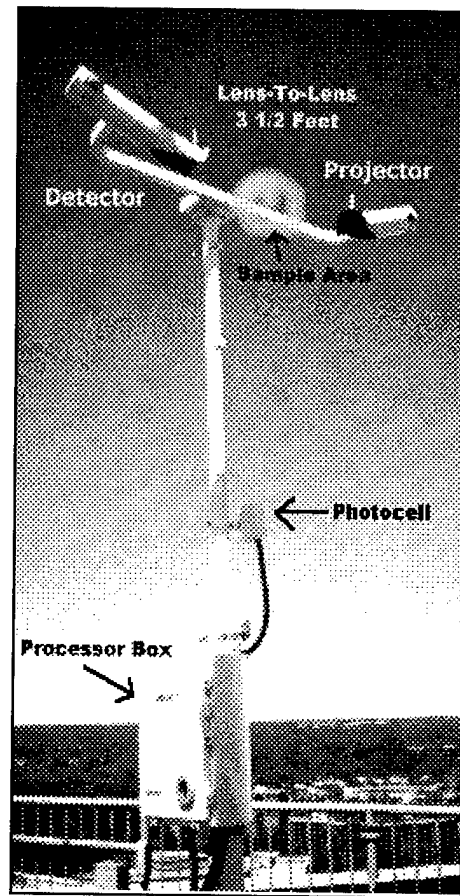

Figure 13. Forward Scatter Visibility Sensor

A photocell on the visibility sensor turns on at dawn or off at dusk at a light level between 0.5 and 3 foot candles (deep twilight). This function determines whether the sensor uses the day or night equation to calculate visibility. For a given extinction coefficient, the day calculation will provide a visibility from 1/2 to 1/3 of that derived by the night equation. Therefore, an abrupt change in visibility may be reported after sunrise or sunset if there is a significant obstruction.

SEV and the prevailing visibility (PV) of the observer are based on different concepts. The SEV in ASOS is derived by frequently measuring the forward scatter characteristics of a small atmospheric sample (0.75 cubic feet) near the sensor and processing these data for 10 minutes. PV, as determined by the observer, relies on visual interpretation of current conditions in a full 360 degree circle around the observation point. This is not done continuously, but only during hourly observation time and when significant weather changes are occurring and noted. SEV and the human-derived prevailing visibility agree most con-

sistently when the weather is homogeneous over a large area; however, testing has shown that there is also strong agreement between human and automated visibilities, even during periods when weather conditions are quite variable.

The AV-AWOS experiments in 1979 showed that the values obtained from three visibility sensors (in a 3-mile triangular arrangement) were, in most cases, in close agreement. Further testing supported the premise that only one sensor, located in a representative area, could be used to describe the visibility for an airport area. It was still recognized that sites plagued by advection fog or other visibility discontinuities would require additional sensors. Every airport required a site survey to properly locate the visibility sensor and identify locations that might need additional sensors.

The location of the visibility sensor(s) was critical. The small sampling volume of the sensor dictated that the sensor be located as near to the area of concern as possible. As a result, most primary visibility sensors were placed near the touchdown zone (TDZ) of the primary instrument runway. The actual siting of the sensors had to meet, as closely as possible, the requirements established by the Federal Standard for Siting Meteorological Sensors at Airports, and the clearance requirements of the FAA. This included consideration of local sources of visibility reduction (e.g., plowed fields, snow blowing operations, and smokestacks), the proper sensor height (at least 10 feet), and adequate obstacle clearances.

4.2.2 Forward Scatter Sensor

The ASOS visibility sensor (Figure 13) operates on a forward scatter principle in which light from a pulsed Xenon flash lamp in the blue portion of the visible spectrum is transmitted twice a second in a cone-shaped beam over a range of angles. The projector and detector are protected with a lens hood and canted down at 15 degrees from the horizon to prevent snow blockage.

The detector "looks" north to minimize sun glare, particularly from low sun angles near sunrise or sunset. To optimally balance the detection efficiency and differentiation ability of the sensor under varying conditions, a nominal 45 degree horizontal incident angle is set between the projector beam and the detector field-of-view within the sampling volume. This is achieved by offsetting the projector about 45 degrees to the left (i.e., northwest) of the detector. As a result, the projector beam does not directly

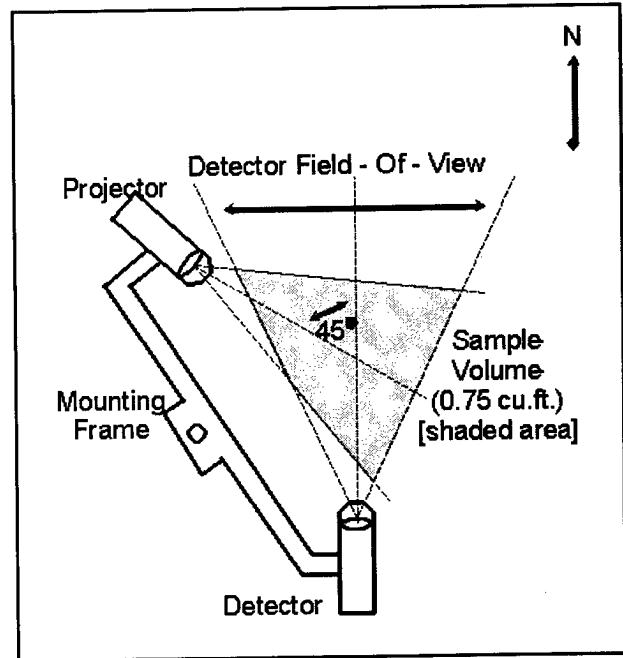

Figure 14. Visibility Sensor—Top View

impinge on the detector lens. Only that portion of the beam that is scattered forward by the intervening medium in the sampling volume is received by the detector (see Figure 14). The sensor sampling volume is 0.75 cubic feet and the sensor response time is 20 seconds. A measurement sample is taken every 30 seconds. Visibility sensor measurement accuracy is specified in reference to comparison with two NWS visibility standards and is summarized in Table 5. In this regard, the forward scatter sensor has shown excellent performance when compared with the "Optec" Transmissometer standards.

Visibility in METAR is reported in statute miles (SM). The reportable increments are: M1/4SM, (less than 1/4SM), 1/4SM, 1/2SM, 3/4SM, 1SM, 1 1/4SM, 1 1/2SM, 1 3/4SM, 2SM, 2 1/2SM, 3SM, 4SM, 5SM, 6SM, 7SM, 8SM, 9SM and 10SM. Note that visibilities between zero and less than 1/4 mile are reported as M1/4SM⁸. Measured visibilities exactly half way between reportable values are rounded down. Visibilities of 10 miles or greater are reported as "10SM."

4.2.3 Visibility Algorithm

The ASOS visibility algorithm samples sensor data every minute, obtaining a 1-minute average extinction coefficient and day/night indication. The algorithm calculates a 1-minute average visibility every minute and stores the value for 10 minutes. Finally, ASOS computes a running 10-minute **harmonic** mean once per minute from the stored data to provide the latest visibility.

⁸ Manual observations of 0, 1/16, and 1/8SM may be augmented.

Table 5. Visibility Sensor—Accuracy in Statute Miles
(As compared to NWS Standard Transmissometer)

ASOS Visibility Measurements	at least 80% of data within these limits.	at least 98% of data within these limits	all data within these limits
0 thru 1 ¼	± ¼	± ½	± 1
1 ½ thru 1 ¾	+ ¼, - ½	+ ½, - ¾	± 1
2 thru 2 ½	± ½	± 1	± 1
3 thru 3 ½	+ ½, - 1	+ 2 RI* / - 1	+ 2 RI* / - 1
4 thru 10	± 1 RI*	± 2 RI*	± 2 RI*

*RI + Reportable Increment

A harmonic mean is used in the final computation rather than an arithmetic mean because it is more responsive to rapidly decreasing visibility conditions and will generally yield a lower value than the arithmetic mean. This result is preferable because it provides an earlier warning of deteriorating conditions. Conversely, when visibilities are rising rapidly, the harmonic mean will be slower than the arithmetic mean in reporting the improving visibility. This conservative bias is intended to provide an additional margin of aviation safety. A 10-minute computation and a harmonic averaging technique was chosen to strike an optimal balance. A longer averaging period tends to dampen short-term non-homogeneous fluctuations while harmonic averaging may respond conservatively to rapidly changing conditions. The harmonic mean is computed from the formula:

$$\bar{V} = n / (1/V_1 + 1/V_2 + \dots + 1/V_n)$$

Where \bar{V} is the harmonic mean, $n = 10$, and V_1, V_2, \dots, V_n , are the individual 1-minute values.

The difference between the harmonic mean and the arithmetic mean can be seen when a fog bank moves in and suddenly drops the visibility from 10 miles to 1/4 mile. Initially there are 10, 1-minute values of visibility equal to 10 miles and both the arithmetic and harmonic mean are reporting 10 mile visibility. In the first minute, there are nine values of 10 miles and one value of 1/4 mile used to compute the current visibility. The arithmetic mean yields 9.025 miles while the harmonic mean yields 2.041 miles. In the second minute, there are now eight values of 10 miles and two values of 1/4 mile used to compute current visibility. In this case, the arithmetic mean is 8.050 miles and the harmonic mean is 1.136 miles.

The value obtained from this computation is then rounded down to the nearest reportable visibility value. This visibility is stored in memory for 31 days as part of the METAR/SPECI reports and made available for distribution. The raw extinction coefficient and day/night settings are stored for 12 hours in the engineering data for maintenance technician monitoring purposes. Eight one-minute data samples in the last 10 minutes are required to form a report. If less than 8 of the current 10, 1-minute visibility values are available in memory, the 1-minute visibility is not reported by ASOS.

The newest visibility value is checked against the visibility reported in the last METAR or SPECI report to determine if it has passed any specified visibility thresholds. If so, ASOS creates a SPECI report. The algorithm also checks for variable visibility. If requirements for variable visibility are met, ASOS generates an appropriate automated remark.

At airport locations with control towers, the ASOS provides the ability to enter tower visibility. If tower visibility is less than 4 statute miles and is also less than the reported surface visibility, then tower visibility is entered in the body of the report and surface visibility is entered in remarks. If, on the other hand, the surface visibility is less than the tower visibility, then surface visibility is entered in the body of the report and tower visibility is entered in remarks.

4.2.3a Meteorological Discontinuity Visibility Sensor

At some airports a second visibility sensor is placed where unique weather, not necessarily representative of the entire airport, may impact flight operations for a portion of the airport or a particular runway. The secondary

meteorological discontinuity visibility sensor may be used to provide an early alert of deteriorating conditions, such as fog rolling in off a nearby bay or river. Whereas the primary visibility sensor is sited near the touch-down zone of the primary instrument runway, the second (meteorological discontinuity) visibility sensor is sited about 2-4 miles away in the most likely location for a meteorological discontinuity.

The data from the primary and meteorological discontinuity sensors are independently processed through the single sensor algorithm and then compared. Only data from the primary sensor is used in the body of the METAR.

If the primary visibility sensor is not operational, the visibility is not reported, a maintenance check indicator (\$) is appended to the METAR, and no further comparisons are made. If the meteorological discontinuity visibility sensor is not operational, the remark "VISNO LOC" is added to the METAR, where LOC is the nominal location of the meteorological discontinuity visibility sensor (e.g., CF, RWY26L), a maintenance check indicator (\$) is appended to the METAR, and no further comparisons made.

If both sensors are operational, a meteorological discontinuity visibility remark is reported when the visibility measured by the meteorological discontinuity sensor is less than 3 miles and is also less than the visibility measured by the primary visibility sensor by one-half mile or more. When these conditions are met, a remark in the form "VIS VALUE LOC" is added to the METAR, where VALUE is the visibility reported by the meteorological discontinuity sensor and LOC is the nominal location of the meteorological discontinuity sensor. For example, a meteorological discontinuity visibility value of 1SM on runway 26L is reported as: VIS 1 RWY26L.

4.2.3b Back-Up Visibility Sensor

A back-up visibility sensor is available at selected major airports where a requirement has been established. It is located within 2 statute miles of the primary visibility sensor and operates continually in "sleep mode," i.e., measurements are taken, stored internally in ASOS, but not included in the METAR report until activated by failure of the primary sensor. The ASOS algorithms process the primary and back-up sensor data separately and determine when data from the back-up sensor are substituted in the observation. When the primary sensor is restored the back-up sensor returns to "back-up" status.

4.2.4 Visibility Strengths and Limitations

One of the main advantages of the visibility sensor is its location at the touchdown zone of the primary instrument runway where it provides a precise visibility value appropriate for that location. Another strength of the sensor is consistency of observations. Under the same weather conditions, an ASOS visibility reported at one site will be identical to the visibility reported at another site because both ASOSs use identical sensors and algorithms. Variations introduced by human observers from such limitations as perspective, sun angle, day and night differences, and poor locations are eliminated.

During certain daylight hours the human eye can readily be affected by light back-scattered toward the observer. This may occur around sunrise or sunset when sunshine is pouring into a low cloud deck or a local weather obstruction, (such as mist, snow, rain, or haze) from behind the observer. In this situation, the bright sky and the back-scattered light can overwhelm the human eye causing the observer to report a lower visibility than ASOS. This back-scattering of light from the sun and sky into the observer's vision by particulates in the air is called "airlight."

Visibility restrictions under back-scatter conditions are considerably less common than under forward-scatter conditions. Under airlight conditions, a direct 180 degree back-scatter reflection is required for reduced human visibility. Visibilities in other directions are not as restricted. Consequently, airlight visibilities are not representative of the entire viewing area. Under forward-scatter conditions, however, ASOS uses a wider 0-45 degree scattering angle range to obtain a more representative measurement of conditions.

The major disadvantage of an automated forward scatter sensor is the small sampling volume (0.75 cubic feet) which can give undue weight to small scale differences in the atmosphere. Even broadening the sample by including all the sensor measurements over a 10 minute period (20 samples) may not provide enough data to create a visibility report that represents the entire airport area. For instance, if patches of fog (BCFG) or shallow fog (MIFG) form, or a fog bank moves over one end of the runway, ASOS may not "see" it if the sensor is not in the right location. Initial site surveys were conducted at each airport to determine proper placement of the primary visibility sensor. Follow-on studies are conducted to decide if additional sensors are needed.

4.3 Automating Present Weather and Obscurations

As noted earlier, the algorithms developed for automated reporting of visibility and sky condition required a new perspective. By contrast, the automated detection and reporting of present weather and obstructions required whole new observing technologies and techniques. Present weather and obstructions arguably are the most complex and difficult elements to automate due to their variety of composition and appearance. Once the first generation of present weather sensors was developed, the reporting algorithms were refined to give a present weather report similar to the human report. Improvements in sensor capability and algorithm sophistication have resulted in the current generation of highly-capable, automated, present weather and obstruction reporting technology.

The ASOS employs a variety of sensors to correctly report present weather and obscurations. A new lightning sensor has recently been added to the ASOS sensor suite at a limited number of sites, which provides information on thunderstorms. The precipitation identification (PI) sensor discriminates between rain and snow; a freezing rain sensor detects ice accretion caused by freezing precipitation; and the visibility sensor and hygrometer provide data for algorithms that further refine the reports of present weather and infer the existence and type of obscuration.

4.3.1 Single Site Lightning Sensor

Where required, the ASOS uses the Global Atmospheric Inc. (GAI) Model 924 single site lightning sensor as a source for reporting a thunderstorm (see Figure 15. Lightning Sensor). The ASOS Lightning Sensor (ALS) is installed at selected Service-Level "D" ASOS sites that do not have the FAA Automated Lightning Detection And Reporting System (ALDARS). The ALDARS is another source of lightning information provided through the National Lightning Detection Network described in Section 4.3.3. The ALS sensor is a single-point omnidirectional system that requires two criteria before reporting a thunderstorm: an optical flash and an electrical field change (radio signal), which occur within milliseconds of each other. The requirement for simultaneous optical and radio signals virtually eliminates the possibility of a false alarm from errant light sources.

The sensor can detect cloud-to-ground and cloud-to-cloud strikes. All strikes are counted, but only the cloud-to-ground strikes are used to generate an estimate of the range. Cloud-to-ground strikes are grouped into three range

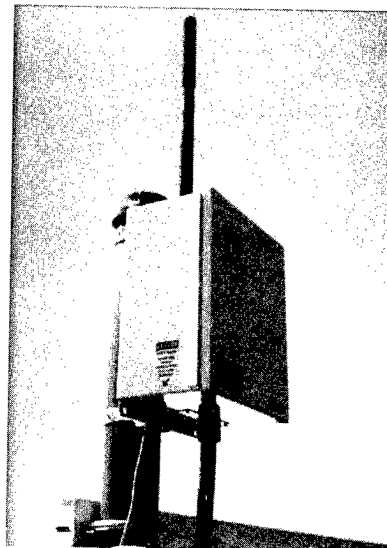

Figure 15: Lightning Sensor

bins: 0 to 5 miles, 5 to 10 miles, and 10 to 30 miles. Because the cloud-to-cloud detection is less efficient than cloud-to-ground detection, the ASOS considers cloud-to-cloud strikes to be within 5 miles.

A cloud-to-ground strike is made up of one or more individual *flashes*. Within one flash, numerous discharges can occur; these individual discharges are called *strokes*. The sensor groups all strokes occurring within 1 second of each other into a single flash. The range of a cloud-to-ground strike is determined by the range of the closest stroke within a flash.

The sensor automatically "ages" each lightning strike for 15 minutes. Because a thunderstorm is defined to be in progress for 15 minutes after the last lightning or thunder occurs, the sensor continues to report each strike in the appropriate bin for 15 minutes after it is first detected. A thunderstorm is determined to end when no strikes are detected within the last 15 minutes.

4.3.2 Single Site Lightning Sensor Algorithm

ASOS polls and processes data from the single site lightning sensor once a minute. The raw sensor data can be viewed through Direct Command Mode using a "THUNDER" command. To determine the starting and stopping times of a thunderstorm, ASOS examines data

in the 0-5 and 5-10 mile cloud-to-ground range bins and in the cloud-to-cloud bin. For the single site lightning sensor, ASOS does not use data in the 10-to-30 mile range bin.

A thunderstorm is declared to start when the *sum* of strikes in the three bins (0-5, 5-10, and cloud-to-cloud) is equal to, or greater than, two. To minimize the possibility of a false alarm, the ASOS algorithm requires two strikes to start a thunderstorm; false alarms are more likely with a single-stroke starting algorithm. ASOS declares a thunderstorm to end when the last strike is "aged" out of the three bins and the sum of the strikes in the three bins falls to zero.

There are two possible thunderstorm reports: "TS" when strikes are occurring within 5 miles, and "VCTS" when strikes are occurring outside 5 miles but within 10 miles. ASOS transmits a SPECI report at the start and end of any thunderstorm condition.

To begin a "TS" report, the two-or-more strike condition must occur in one of the following formats:

- 0-5 bin only
- cloud-to-cloud bin only
- 0-5 and 5-10 bins
- 0-5 and cloud-to-cloud bins
- cloud-to-cloud and 5-10 bins
- 0-5, 5-10, and cloud-to-cloud bins

A "VCTS" report is transmitted when the strikes occur only in the 5-10 mile bin. If a thunderstorm begins as a "VCTS" report, and a single strike is detected in either the 0-5 or the cloud-to-cloud bin, the report is changed to "TS." Similarly, a "TS" report will be changed to "VCTS" when the only strikes detected are occurring in the 5-10 mile bin.

4.3.3 Automated Lightning Detection And Reporting System

A potential alternative source of lightning information is the National Lightning Detection Network (NLDN) operated by GAI. It consists of approximately 100 lightning direction finder sensors located throughout the Continental U.S. (CONUS). The sensors record the parameters of each cloud-to-ground lightning strike with precise time and location. All strike reports are sent by satellite to the GAI processing center at Tucson, AZ, where a computer processing algorithm compares strike reports from multiple sensors, computes each strike location, and provides this information to the FAA communications network within seconds of the strike.

The FAA has constructed a processing architecture called Automated Lightning Detection and Reporting Systems (ALDARS) at each of the 20 Air Route Traffic Control Centers (ARTCCs) in the CONUS. There is no NLDN lightning coverage in Alaska or Hawaii. The AWOS Data Acquisition System (ADAS) at each ARTCC filters NLDN data for its particular ARTCC coverage area and identifies strikes within 30NM of any Airport Reference Point (ARP) within the ARTCC coverage area. A strike is placed in one of three range bins: within 5NM of ASOS (at the airport), 5-10NM of ASOS (vicinity of the airport), and 10-30NM (distant from ASOS). These data are sent to the ASOS by the ADAS where they are processed and treated by ASOS as any other sensor derived data, and are included in the transmitted ASOS reports when appropriate. At sites that may concurrently receive ALS and NLDN-ALDARS information, the ALS data will take precedence for processing and reporting by ASOS. Current plans, however, call for no sites to have both ALS and ALDARS data.

4.3.4 ASOS Lightning Sensor Strengths and Limitations

- The ALS occasionally reports valid lightning within 10 miles when thunder cannot be heard by an observer. An extensive field evaluation in the summer of 1997 indicated that the sensor can report 15-20% *more* valid thunderstorm minutes than an observer, primarily because an observer's ability to hear thunder at most airports is restricted.
- Due to the two-part criterion (optical and radio) for identifying lightning strikes, the sensor has an inherently low false alarm rate. The 1997 field evaluation indicated a false alarm rate of 0.0039 (i.e., about 0.4 percent of ASOS thunderstorm minutes may be false).
- The ranging estimates provided by the sensor have significant uncertainty and can contribute to reporting thunderstorms when cells are beyond 10 miles. A very strong lightning strike at 15-20 miles can be erroneously placed in the 5-10 mile bin by the ASOS sensor.
- The 1997 field evaluation identified cloud-to-cloud strikes detected at ranges near 30 miles. The cloud-to-cloud bin was retained in the ASOS algorithm because of the importance of cloud-to-cloud lightning in identifying thunderstorms. A significant number of thunderstorms contain primarily cloud-to-cloud lightning and if it were eliminated from the reporting algorithm, there would be a risk of failing to report thunderstorms.

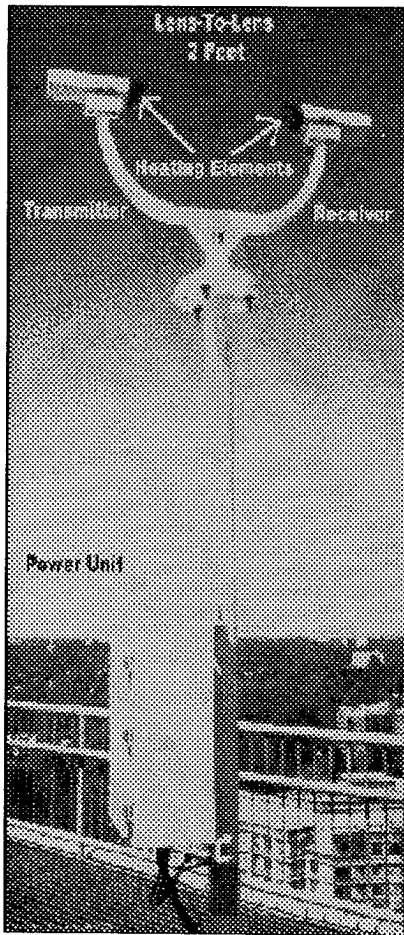

Figure 16. The Precipitation Identification Sensor

4.3.5 Precipitation Identification Sensor

The Precipitation Identification sensor (PI), better known as a Light Emitting Diode Weather Identifier (LEDWI), differentiates rain from snow and determines the intensity of the precipitation.

The LEDWI contains a coherent light transmitter (i.e., there is a continuous relationship among the various phases of the light waves within the beam) and a photo diode receiver. The transmitter and receiver are mounted on a cross-arm 10 feet above the ground or base of the platform. They are equipped with heated lens hoods, face directly at each other, are separated by a distance of 2 feet and are oriented in a north-south direction with the receiver looking north. (See Figure 16 for a view of the LEDWI.)

The transmitter generates a coherent Infrared (IRED) light beam, 50 millimeters in diameter, aimed directly at the receiver. The receiver lens is masked with a narrow

1 millimeter horizontal slit aperture through which the transmitter light beam passes before it is focused by the lens and impinges on the photo diode. The narrow aperture makes the receiver more sensitive to beam fluctuations caused by particles down to the size of a small raindrop (0.04 inch diameter).

Because the slit is much wider than its height, the receiver is more sensitive to beam fluctuations induced by the vertical velocity component of particles passing through the beam than the horizontal component. Built-in sensor algorithms minimize the possibility of any false identification caused by greater sensitivity.

As a particle of rain or snow passes through the coherent light beam, the particle creates a shadow that modulates the light, which then passes through the receiver's horizontal slit aperture as a partially coherent (intermittently disrupted), collimated (parallel to the slit) beam. The shadow varies depending on the size and speed of descent of the particle as it falls across the receiver.

When many particles fall through the beam, a scintillation pattern is created. The fluctuating beam pattern is sensed by a photo diode and amplified, creating a jumble of frequencies containing information on the size and speed of the falling particles. A spectral analysis reveals how much energy or power is contained in the various frequency bands. For example, a predominance of power in low frequencies from 75 to 250 Hz indicates snow. When energy is predominantly in a band from 1000 to 4000 Hz, the precipitant is almost certainly rain. The LEDWI registers rain and snow mixed as a "smearing" of the spectral power, which is usually reported by ASOS as unknown precipitation (UP). This analysis is the basis of the discrimination algorithm, which differentiates rain from snow.

When the precipitation is not mixed, (i.e., pure rain or pure snow) the LEDWI can determine the intensity of the precipitation. The intensity is determined by the power of the signal return in the rain (1-4 kHz) or snow (75-250 Hz) portion of the power spectrum. The power return of rain is derived from the size and fall velocity of the particles whose size distribution, correlates well with liquid water content. It is possible to accurately determine the rain intensity through an empirical relationship (the Marshall-Palmer distribution), which can distinguish light (up to 0.10 inch per hour), moderate (0.11-0.30 inch per hour), or heavy (greater than 0.30 inch per hour) intensities for rain.

In the case of snow, it is again the size and fall velocity of the snowflakes that determines their size distribution. This correlates well with rate of snow accumulation. Unlike rain however, the density of snow can vary significantly depending on whether the snow is "wet" or "dry," and so the liquid content cannot be accurately determined.

The LEDWI report of intensity is well correlated with the rate of snow accumulation but is not directly related to the visibility reduction due to snow, which observers use to differentiate between light, moderate, and heavy snow. ASOS processing algorithms use the visibility sensor data to modify the LEDWI snow intensity report so that moderate snow is not reported when the visibility is greater than 1/2 mile and heavy snow is not reported when the visibility is greater than 1/4 mile.

The LEDWI has an "adaptive baseline," which adjusts the power spectrum threshold to reduce reports of false precipitation. For instance, wind turbulence and thermals (e.g., the shimmer seen across an open field on a sunny day) can induce scintillations that are near the frequencies characteristic of snow. Therefore, ASOS sets the threshold for snow detection above the spectral power induced by turbulence.

This "adaptive baseline" can pose a problem when snow increases so slowly that the baseline rises without snow being detected. When this occurs, only a sudden increase in snow may trigger the sensor to report snow. A similar condition may occur when the LEDWI is turned on (say after a power failure) and precipitation is falling. The initial adaptive baseline may be set much too high to detect precipitation correctly and will not be reset to a representative threshold until the precipitation ends.

Rain detection is generally not a problem. Occasionally, if the rain is preceded by a gradually increasing drizzle, the rain channel adaptive baseline threshold may rise to a point where light rain is not sensed. As a general rule, rain lighter than 0.01 inches per hour will not be detected.

4.3.6 PI Algorithm

Every minute, the PI algorithm requests the PI sensor data, stores the data in memory for 12 hours, and examines the latest 10 minutes of data stored in memory. If three or more samples are missing, the algorithm sets the sensor status to "inoperative" and reports "missing" for that minute. If the 10-minute memory buffer contains less than two sensor samples of precipitation, the precipitation report terminates.

If, however, two or more samples in the latest 10 minutes indicate precipitation, the algorithm then determines the type and intensity to report. In general, to report anything other than "Unknown Precipitation" (UP), two of the samples are required to be the same type. If there is a tie between two types of precipitation (e.g., two rain samples and two snow samples) snow is reported. This determina-

tion is based on the hierarchical scheme for reporting present weather: liquid (-RA, RA, +RA), freezing (-FZRA, FZRA), and frozen (-SN, SN, +SN) in ascending order.

ASOS reports only one precipitation type at a time. For instance, if both freezing rain and snow are detected, snow is reported. Additional precipitation elements may be added to the report by observers. The PI algorithm performs a temperature check on the PI sensor output. If -SN, SN, or +SN is reported, and the temperature is > 38 F, then the PI sensor output is set to "No Precipitation" (NP). The PI algorithm also formats and reports precipitation beginning and ending remarks just as the observer does.

Once the precipitation type is determined from the last 10 minutes of data, then the 1-minute samples from the past 5 minutes are used to compute intensity. Precipitation intensity is determined from the highest common intensity derived from three or more samples. Common intensities for heavy precipitation are light, moderate and heavy; for moderate precipitation, common intensities are light and moderate. For example, if rain is the determined precipitation type, and there are three moderate rain and one light rain detected in the past 5 minutes, then ASOS reports moderate rain in the METAR/ SPECI report. Likewise, if snow is the determined type and there are one light, two moderate, and one heavy snow in the past 5 minutes, then moderate snow is reported.

As a third example, if the most recent 5 minutes of sensor data contains one report of light rain, and two reports of moderate rain, then light rain is reported by ASOS. If, on the other hand, there are less than three common intensities of the reported precipitation type, then ASOS reports the lightest intensity. For example, if rain is the determined type, and there are only one moderate rain and one heavy rain reported by the sensor, then the precipitation intensity is set to moderate rain (RA) in the ASOS METAR/SPECI report. If snow is the determined precipitation type and there are only one moderate and one heavy snow, then ASOS reports moderate snow.

The ASOS PI algorithm formats and reports precipitation beginning and ending remarks just as the observer does. The PI sensor output is further compared with the freezing rain sensor output to ultimately determine the precipitation reports and remarks (see description of the freezing rain algorithm for further details).

Under blowing snow conditions, particularly where snow is blown to a height of 10 feet or more, the PI sensor (LEDWI) can mistakenly interpret the scintillations from blowing snow rising up and/or settling through the sensor's IRED beam as rain, and occasionally as snow, depending on the vertical velocity of the snow particles.

At higher wind speeds (10 knots or greater), the upward vertical velocity of the snow particles usually is sufficient to be incorrectly interpreted as rain. The ASOS blowing snow algorithm interrogates the LEDWI and other ASOS sensors for concurrent blowing snow conditions and rain reported by the LEDWI. When this "error" is detected, ASOS replaces the false LEDWI rain report with a correct blowing snow report in the ASOS METAR/SPECI present weather field. This change is made by evaluating sky condition and 15-minute average data for ambient temperature and wind. A 15-minute average is used to reduce the risk of the output oscillating from one present weather report "solution" to another. ASOS evaluates all LEDWI reports of rain with an ambient temperature of 32 °F or less. Under these conditions, either blowing snow (BLSN) or unknown precipitation (UP), is reported in the present weather field. When all data are available, ASOS reports blowing snow when:

- Visibility is less than 7 statute miles
- Ambient temperature is 14 °F or less
- Sky cover is less than overcast or the ceiling height is greater than 10,000 feet
- Wind speed is greater than 22 knots,

If these conditions are not met, ASOS reports UP.

4.3.7 PI Strengths and Limitations

Because of its continuous monitoring capability, the ASOS PI sensor often detects and reports the beginning and end of rain or snow before an observer. In addition, because of its sensitivity, the PI sensor can detect light precipitation even at times when it cannot distinguish between rain and snow (as the observer can). In these situations, the ASOS may report too many "UPs." Earlier updates to the sensor and the algorithm minimized generation of excessive remarks (e.g., UPB04E07R AB07E14UPB14, etc).

Because drizzle particles are small and fall slower than raindrops, their power spectrum is weak and smeared; therefore, drizzle is often not detected. On occasion, however, it may elevate either the high or low frequency channel of the PI sensor sufficiently to be reported as rain or snow. When light drizzle is falling, the PI sensor may, on occasion, interpret the scintillation pattern created by these suspended water droplets as light snow when the temperature is $M < 38$ F. Product improvement efforts are aimed at reliably detecting and correctly reporting drizzle (see Section 7.2.5).

Ice pellets (PE) and rain have a similar size and fall velocity. Consequently, ice pellets will force an output from the PI sensor of either UP, -RA, RA, or +RA (depending

on intensity of the ice pellets). The PI sensor will more likely interpret this as rain and output -RA, RA, or +RA rather than UP. The ASOS processing algorithm will, in turn, also report either -RA, RA, or +RA, as output by the PI sensor.

ASOS may report other types of frozen precipitation as rain or snow, depending on the scintillation pattern caused by their size and fall velocity. For example, snow grains are larger than drizzle and fall slower so they are sometimes reported as snow. Snow pellets also fall slower than raindrops and will therefore be reported as snow. Hailstones are larger than raindrops and fall faster, and therefore will be reported as rain.

In mixed precipitation conditions, such as snow and ice pellets, the PI sensor likely interprets the ice pellets as rain (see above). The snow, however, has a higher reporting precedence and thus snow will be reported by the processing algorithm. A mixture of snow grains and drizzle may also be reported as snow. In cases where snow grains are mixed with freezing drizzle, ASOS will either report snow or no precipitation.

Sometimes the LEDWI may sense non-atmospheric phenomena. For example, insects flying in the receiver field of view can cause it to report precipitation. Spiders that run threads between the cross arms can trigger a false precipitation report when the wind moves the threads up and down. Even sun glint, particularly on a bright day when there are snow crystals (diamond dust) floating in the air, can trigger false precipitation indications.

Strong winds during snow and blowing snow occasionally pack the receiver or projector heads of the LEDWI with snow. A total blockage of the lens will cause a loss of any detected signal creating an error condition. A partial blockage may contaminate the measurement and lead to inaccurate reports of precipitation type or intensity. An intensive ongoing effort is underway to eliminate the problem and prevent lens blockage.

4.3.8 Freezing Rain Sensor

The ASOS Freezing Rain (FZRA) Sensor is based on technology initially developed to detect icing on aircraft in flight. The sensing device consists of a small cylindrical probe that is electrically stimulated to vibrate at its resonant frequency. A feedback coil is used to measure the vibration frequency, which is proportional to the mass of the probe. Figure 17 shows the design of this "magnetostrictive oscillator" (i.e., Freezing Rain Sensor). Magnetostriction is a property of certain metals in which

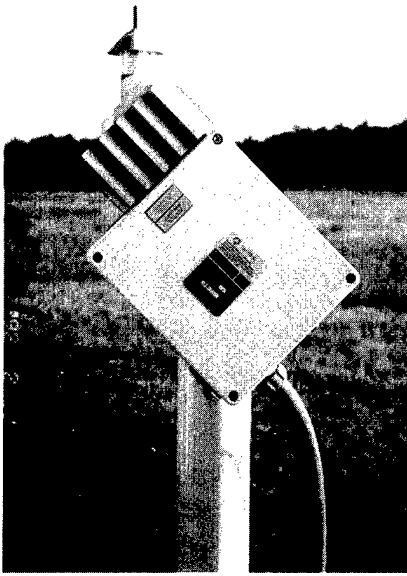

Figure 17. Freezing Rain Sensor

a change in the (axial) dimension of a body caused a change in magnetization. It is used in the ASOS sensor to drive the probe at a natural resonant frequency of 40kHz. The axial vibration is of such low amplitude that it cannot be seen or felt. The probe is orientated vertically to provide optimal uniform exposure to freezing precipitation regardless of wind direction. This position also prevents birds from alighting.

When ice freezes on the probe, the combined mass increases and the resonant vibration frequency decreases. There is a well defined relationship between the measured frequency and the ice accretion on the probe. The freezing rain instrument is sensitive enough to measure accumulation rates as low as 0.01 of an inch per hour. The freezing rain sensor continuously monitors the resonant frequency of the vibrating probe, obtains a sample once a second, and once each minute averages the results to update the probe's current resonant frequency. When excessive freezing rain accumulates, (i.e., equal to or greater than 0.08 inch) the sensor goes into a heating cycle to melt the freezing rain from the probe and return it to the base resonating frequency. This process normally takes two to three minutes. During this time, the sensor status is set to "deice" and the output is not updated.

4.3.9 FZRA Algorithm

Once each minute, the freezing rain algorithm accesses the current 5-minute average ambient temperature and the current frequency output from the freezing rain sensor and

stores this data in memory for 12 hours. Data from the last 15 minutes are used to compute the current 1 minute freezing rain report. If three or more freezing rain sensor outputs in the last 15 minutes are missing, the sensor status is set to "inoperative," and the freezing rain report is set to "missing." The current minute's frequency output is converted to an ice accretion thickness using the following equation:

$$Z_t = (40,000 - F_n) * 0.000152$$

Where Z_t is the current ice accretion thickness in inches and F_n is the current sensor frequency.

Each minute the Freezing Rain sensor outputs a report. The Freezing Rain report is set to "FRZA" under the following combined conditions:

- If the current ice accretion exceeds 0.005 inch,
- If the current ice accretion exceeds the minimum accretion since the sensor was last declared operational or during the past 15 minutes, whichever is less, by 0.002 inch
- If the current five-minute ambient temperature is less than 37°F.

Otherwise, the freezing rain report is set to indicate a lack of freezing precipitation for the current minute. The freezing rain report for each minute is saved for 15 minutes. Finally, the freezing rain report is checked against the present weather report from the previous minute and special alert criteria for the beginning and ending of freezing precipitation, or changes in intensity, and if necessary a SPECI will be generated.

Table 6 shows the reporting scheme for the ASOS Present Weather Report. The reporting scheme follows the familiar hierarchy of LIQUID-FREEZING-FROZEN, in ascending order of priority. Only the highest priority precipitation phenomena observed will be reported at any one time (i.e., ASOS does not report mixed or multiple precipitation types). For example, if the freezing rain sensor indicates "-FZRA" and the precipitation identifier reports "UP", then the ASOS will report "-FZRA."

The previous minutes' present weather reports are further examined to determine which present weather remarks need to be generated and appended to the METAR report. This includes precipitation beginning and ending times in minutes past the current hour (e.g., FZRAB05E21). Once freezing rain has been sensed and the ambient air temperature is 36°F or below, it will be encoded in subsequent METAR reports for 15-minutes after it is no longer sensed.

4.3.10 FZRA Strengths and Limitations

The major strength of the freezing rain sensor is its sensitivity and continuous monitoring, usually allowing it to detect freezing precipitation conditions before an observer, especially at night. Working in conjunction with other sensors, mixed precipitation events can be better defined. For example, under conditions of mixed precipitation, such as ice pellets (PE) and freezing rain (FZRA), the PI sensor will output UP, -RA, RA, or +RA (for the PE), and the FZRA

Table 6. Present Weather Reporting Hierarchy

Freezing Rain Sensor Report	Precipitation Identification Sensor Report	ASOS Present Weather Report
FZRA	No Precip.	NP
FZRA	Missing	NP
FZRA	UP	- FZRA
FZRA	- RA	- FZRA
FZRA	RA	FZRA
FZRA	+RA	FZRA
FZRA	- SN	- SN
FZRA	SN	SN
FZRA	+SN	+SN

sensor will output FZRA. In any event, the ASOS processing algorithms will finally interpret and correctly report this condition as -FZRA or FZRA (see Table 7).

At temperatures near freezing, snow can become attached to the probe firmly enough to cause a frequency shift that could be misinterpreted as freezing rain. This problem of differentiating snow from freezing precipitation is overcome by checking the output of the PI sensor to determine if it is raining or snowing when the freezing rain sensor has a frequency shift. If the PI sensor indicates rain, then the report will be freezing rain. If the PI sensor indicates snow, then snow will be reported in the body of the METAR message.

4.3.11 Obscuration Algorithm

Obstructions are not directly measured by ASOS, but rather inferred from the measurement of visibility, temperature, dew point, and present weather (precipitation). ASOS reports only four obstructions: fog (FG), mist (BR),

freezing fog (FZFG) and haze (HZ). Other obscurations, such as dust, smoke, and blowing sand are not automatically reported by ASOS, but may be augmented by the observer in accordance with agency policy.

The obscuration algorithm checks the reported visibility once each minute. When the surface visibility drops below 7 statute miles, the algorithm obtains the current dew point depression (DD) to distinguish between FG, BR, and HZ. If the DD is less than or equal to 4°F (~2° C), then FG or BR will be reported (Table 8). Visibility will then be used to further differentiate between FG and BR. If the visibility is less than 7 miles and down to 5/8ths of a mile, BR is reported. If the visibility is less than 5/8ths of a mile, FG is reported. If the ambient temperature is also below freezing, freezing fog (FZFG) is reported. When precipitation is reported, FG or BR may also be reported when the preceding conditions are met. When the DD is greater than 4°F (~2° C) and no precipitation is reported by the PI and freezing rain sensors, then HZ is reported as the obscuration; however, when precipitation is reported HZ is not reported.

Table 7. ASOS Report of Freezing/Frozen Phenomena

Type of Weather Occurrence	ASOS Present Weather Report
Ice Pellets (PE)	-RA, RA, or +RA
Ice Pellets and Snow (SN)	-SN, SN, or +SN
Ice Pellets and Freezing Rain	-FZRA, or FZRA
Ice Crystals	No Precipitation
Hail (GR)	+RA
Snow Grains (SG)	-SN, SN, or +SN
Snow Pellets (GS)	-SN, SN, or +SN

In the event the DD is missing (i.e., temperature and/or dew point is missing) the obscuration algorithm relies solely on visibility to discriminate between FG, BR and HZ. If the reported visibility is less than 7 miles and equal to or greater than 4 miles, HZ is reported. If the visibility is less than 4 miles and down to 5/8ths of a mile, then BR is reported as the obscuration. If visibility is less than 5/8ths of a mile, FG is reported. When present weather is also reported, FG or BR is appended to the present weather re-

Table 8. ASOS Report of Present Weather

°F			VIS	PRESENT WEATHER	
T	T _d	DD		PRECIPITATION	OBSCURATION
28	20	8	3	NONE	HZ
28	27	1	1/4	SN	SN FZFG
28	22	6	5	NONE	HZ
38	37	1	1/2	NONE	FG
38	34	4	5/8	NONE	BR
40	M	M	4	NONE	HZ

port. If reported visibility is equal to or greater than 4 miles but less than 7 miles, and no present weather is reported, then HZ is reported as the obscuration.

4.3.12 Obscuration Algorithm Strengths and Limitations

One obvious characteristic of the obscuration algorithm is that FG or BR cannot be reported, even if it is the only obstruction to vision, when the DD is greater than 4°F or when DD is missing and visibility is 4 miles or more. In these situations, if FG or BR is actually occurring, then HZ is incorrectly reported when the visibility is less than 7 miles. The ASOS, of course, cannot report obscuration remarks for distant phenomena such as "FG BANK NE-SE." The ASOS, on the other hand, will provide more timely reporting of the formation and dissipation of obscuring phenomena due to its continuous monitoring capability.

CHAPTER FIVE

5.0 Explanations/Examples of ASOS Observations

ASOS provides six basic types of data:

- 5-Second Wind Update
- The OMO Data
- The METAR / SPECI Messages
- Auxiliary Data
- The SHEF Messages
- The Daily and Monthly Summary
- Products/Messages

5.1 5-Second Wind Updates

The current 2-minute average wind is computed once every 5 seconds and automatically updated on FAA provided ASOS Controller Equipment (ACE) video displays at selected sites. A list of the 24 most recent 5-second average wind values used to compute the current 2-minute average wind is also available on the OID screen. (See Appendix A for example of 5-second average wind).

5.2 One-Minute Observations

Once each minute, ASOS performs internal diagnostic and QC checks on sensor data and then updates the One Minute Observation (OMO). The OMO is encoded in METAR format and includes all basic weather parameters found in the body of the METAR plus selected automated remarks. The OMO also accepts manually entered remarks (via OID keyboard entry), such as variable visibility and tower visibility. The basic difference between the OMO and the METAR/SPECI is that the OMO is generally not transmitted long-line beyond the local FAA or NWS communications network node (see bullet 3 below). OMO information is collected during the 60-second period ending at M+00 and made available to users each minute at M+23 (23 seconds past the current minute) through the following media:

- **OID, VDU, and authorized dial-in user computer display screens.** Various screen displays of OMO data are available. See Appendix A for examples, and the *ASOS Software User's Manual (SUM)* for details.

- **Computer-generated voice messages of the current OMO (or METAR / SPECI).** These messages are sent to pilots (generally within 50 miles of an airport) through the ASOS Ground-To-Air VHF radio or navigation aid. They are also made available to the aviation community through telephone number provided for dial-in.
- **Long-Line Dissemination:** OMO data will **not** be sent over long-line until both the modernization of the FAA and the NWS communications networks is complete (see Figures 18 and 19). At that time, FAA ADAS and NWS AWIPS communications nodes will collect OMO data from local ASOS locations. These data will be made available to FAA and NWS users in METAR format. Future communication links will allow each NWS WFO to access the OMO data from selected ASOS locations every 5-minutes when operating in the "warning" mode, or every 15-minutes when operating in the "alert" mode.

5.3 ASOS Aviation Routine Weather Reports

All ASOS locations prepare and disseminate Aviation Routine Weather Reports in METAR / SPECI code format. Although ASOS is designed to operate completely unattended, it can also function in an attended mode with an observer augmenting data and providing backup support if needed. In either case, the ASOS report is identified by the "AO2" designator near the beginning of the remarks (RMK) section of the report. This indicates that the ASOS report is an Automated Observation-Type 2, with the added capability to report present weather phenomena (e.g., RA, SN, FZRA). When operating in the unattended mode, an "AUTO" report modifier is inserted near the beginning of the report after the Date-Time group.

When operating in the attended mode, the AUTO designator does not appear. The absence of the AUTO designator indicates that an observer and/or an air traffic controller is signed-on to the OID and is capable of providing backup or augmentation support if necessary. Only one observer is permitted to sign-on the ASOS at a time. Remote (off-site) observer sign-on is not permitted. If the observer corrects the ASOS METAR/SPECI report, the "COR" indicator appears as the report modifier after the Date-Time group. When the observer and the air traffic

controller are both signed-off the ASOS, the AUTO report modifier is restored to the METAR/SPECI report.

When an aircraft mishap occurs, the on-site observer can (and should) initiate a local special observation. In this event, the remark "(ACFT MSHP)" is appended to the local SPECI report, which is sent to the ASOS printer and stored in memory for 31 days. The long-line version of the SPECI report is sent without the (ACFT MSHP) indicator.

All ASOS reports that are transmitted through the NWS long-line communications network are captured at the NWS Systems Monitoring and Coordination Center (SMCC) and compiled with other transmitted data into a daily Selective Records Retention System (SRRS) tape. This tape is sent to the National Climatic Data Center (NCDC) once a day for archiving and inclusion in various climatic summaries. NCDC also directly downloads data from selected sites for special climatological processing.

5.3.1 Backup and Augmentation

"Backup" is observer editing of the ASOS report for missing, clearly erroneous, or temporarily unrepresentative elements that ASOS should report correctly, or transmission of an entire report when total ASOS equipment failure has occurred. This activity may include use of alternative data sources and transmission medium. Only data elements normally generated by ASOS are added to the ASOS observation through backup. Backup may be applied to the ASOS-generated METAR/SPECI reports or to daily and monthly summary products. For example, backup could occur if the ASOS Hygrothermometer becomes inoperative and the temperature/dew point data are omitted in the METAR. To backup the ASOS observation, an observer using alternate source(s) of information manually edits temperature/dew point data into the ASOS observation in place of the missing data (See Example 1 in Section 5.3.4). This complete observation is then transmitted as the METAR report.

Augmentation is the process of manually adding information to an ASOS METAR/SPECI report or Daily Summary Message / Monthly Summary Message (DSM / MSM) product that is beyond the capability of ASOS to provide on its own. This task is performed before transmission. FAA/NWS policy permits augmentation at designated locations where qualified staff are available.

Edited and augmented data are processed by the ASOS when computing the daily and monthly summary products. For example, if the operator edits a temperature in a METAR report, that edited temperature value would auto-

matically be used to compute the daily and monthly summary temperature information for the site. The extent of backup and augmentation provided at each location is dependent on the national and regional policies of the host agency. Each agency provides observer support in coordination with interagency NWS/FAA and aviation industry agreement on the service level assigned to each location.

5.3.2 Missing vs. Non-Event Data

Generally, if less than 75 percent of the data required for the computation of any weather element for the METAR/SPECI report are available, then ASOS simply does not report that element. For example, if three 1-minute visibility values are missing in the past 10 minutes, then the current 1-minute visibility will be missing. One notable exception to the 75 percent rule is that precipitation accumulation requires nearly 100 percent of the 1-minute data samples during the accumulation period. For example, if just one 1-minute precipitation accumulation value is missing in the past hour, then the current hourly precipitation accumulation report will be missing.

When a schedule-driven or event-driven data element is missing in the *body* of the METAR/SPECI report, the corresponding group and the preceding space for that data element are omitted from the report. Trailing elements in the report shift to fill in the blank space left by the omitted data.

Schedule-driven elements should always appear in the METAR/SPECI report: Wind, Visibility, Sky Condition, Ambient and Dew Point Temperature, and Altimeter. It is readily apparent from the compressed form of the report when these elements are missing. For event-driven (i.e., criteria triggered) elements such as runway visual range, present weather and obstructions, it is not always clear from the report that their omission is due to missing data or simply because the event has not occurred.

To clearly show when event-driven elements are missing, a sensor status indicator is added to the remarks section when ASOS cannot report the element. A sensor status indicator is also added to the remarks section when event-driven meteorological discontinuity sensor data for secondary visibility and/or sky condition are not available. Additionally, a sensor status indicator is included in the remarks section when the event-driven hourly precipitation accumulation remark is not available. Finally, although Sea-Level Pressure (SLP) information is included in both the METAR and SPECI reports from ASOS, a sensor status indicator for missing SLP is only added to the METAR report when SLP information is not available. The sensor status indicators are:

- RVRNO—Runway Visual Range Information Not Available
- FZNO—Freezing Rain Sensor Information Not Available
- PWINO—Present Weather Identifier Information Not Available
- TSNO—Thunderstorm Information Not Available
- PNO—Precipitation Accumulation Gauge Information Not Available
- SLPNO—Sea Level Pressure Information Not Available
- CHINO LOC—Cloud Height Indicator Information at Meteorological Discontinuity Location Not Available (e.g., CHINO E)
- VISNO LOC—Visibility Sensor Information at Meteorological Discontinuity Location Not Available (e.g., VISNO RWY06)

In general, when data for an automated remark are not available the remark is omitted from the METAR/SPECI report. A notable exception is when more than a trace of precipitation has occurred but accumulation data for the period is incomplete (i.e., some data are missing and therefore the amount is undetermined). In this case, the 3/6 hourly and 24 hourly precipitation accumulations are coded as 6//// and 7////, respectively.

5.3.3 Estimated Data

The *Federal Standard Algorithms for Automated Weather Observing Systems Used for Aviation Purposes* (November 1988), does not allow an automated system to use algorithms to generate estimated data for a METAR/SPECI report. Because ASOS conforms to the federal standard, estimated automated data is not included in any ASOS generated METAR/SPECI report. Estimated data however, may be manually included in the ASOS METAR/SPECI report through backup when the automated data are missing or deemed inaccurate. The METAR/SPECI report does not indicate whether a data element has been estimated.

5.3.4 Examples of METAR/SPECI Reports

The examples in this section conform to the FMH-1, Federal Meteorological Handbook No. 1, Surface Weather Observations and Reports (December 1995). See Appendix C for a quick reference guide for the ASOS-generated METAR/SPECI reports.

Example 1: Missing Data

METAR KSPI 021156Z AUTO A3029 RMK AO2
SLPNO 6//// 7//// 51018 PWINO FZANO TSNO RVRNO
PNO \$

At this automated site where observer oversight is not available, the word "AUTO" is encoded after the date/time group. In the remarks section, the "AO2" indicates that this is an automated system with a precipitation discriminator. In other words, this site can report the occurrence of precipitation in the present weather field. In this METAR report, the only element reported is the altimeter (A3029). If an element is missing, METAR code does not permit an "M" to be encoded. Missing elements are simply not encoded. The only exceptions to this rule are found in the remarks section. When sea-level pressure is missing, "SLPNO" (sea-level pressure not available) is encoded. When precipitation accumulation amounts are not available, the 3- or 6-hourly and 24-hourly precipitation additive data groups, i.e., 6RRRR and 7RRRR, will appear as "6////" and "7////." METAR code does allow for sensor status indicators to be encoded at the end of the report. Since this site is in need of maintenance, a maintenance indicator (\$) is placed at the end of the report.

Example 2: Full Report

METAR KMTJ 031153Z AUTO 36003KT 3SM -SN BR
BKN009 BKN016 OVC070 00/M01 A3008 RMK AO2
SNB1057 CIG 006V010 SLP166 P0000 60000 70002
T00001006 10017 20000 51005 FZANO TSNO

This 1200 UTC report is from a fully operational automated site without observer oversight. Because the site does not have a freezing rain sensor installed and does not have the capability to automatically report thunderstorms, FZANO and TSNO are encoded in the remarks section. The obscuration mist (BR) has been encoded since the surface visibility is less than 7SM, but greater than or equal to 5/8SM, and the dew point depression is less than or equal to 4° F. ASOS automatically provided all of the encoded data including the begin time for the snow (SNB1057), the variable ceiling height remark (CIG 006V010), and the sea-level pressure value (SLP166).

Example 3: Surface Visibility vs. Tower Visibility

SPECI KDEN 060409Z 03008KT 2 1/2SM BR OVC003
M06/M07 A3012 RMK AO2 TWR VIS 3 VIS 1 1/4V5

This SPECI report is from a site with observer oversight; note that the AUTO indicator after the date-time group is omitted. In this report both the surface, sensor derived visibility and the tower, human derived visibility are included. When the tower visibility is less than 4SM, the lower of the two visibility values is encoded in the body of the report and the other is included in the remarks section. In this case, the surface visibility is lower and therefore encoded in the body, while the tower visibility is found in the

remarks section of the report. The tower visibility is manually entered into the ASOS report through the OID. The variable visibility remark (VIS 1 1/4V5) is automatically provided by ASOS and refers to the surface visibility.

Example 4: Meteorological Discontinuity Sensor Data

a: METAR KBOS 291856Z 03006KT 1 3/4SM BR FEW001 SCT019 BKN023 12/10 A2961 RMK AO2 SFC VIS 3 CIG 018 E SLP028 T01170100 \$

The tower visibility is 1 3/4SM and the surface (sensor) visibility is 3SM. In this case, the tower visibility is encoded in the body of the report and surface visibility is placed in remarks (SFC VIS 3). A meteorological discontinuity sensor grouping (ceilometer and visibility sensor) is located east of the primary ASOS sensor suite. A ceiling height of 1,800 feet is being reported east of the primary sensors (CIG 018 E). If the meteorological discontinuity ceilometer was not operational, then the remark "CHINO E" would have been encoded.

b: SPECI KBOS 291710Z 06004KT 1 1/2SM BR OVC001 09/08 A2970 RMK AO2 SFC VIS 1 3/4 VIS 1/2 E \$

A visibility remark (VIS 1/2 E) has been encoded for the meteorological discontinuity sensor installed east of the primary sensors. If this visibility sensor were not operational, then the remark "VISNO E" would have been encoded.

c: METAR KBOS 292256Z 04004KT 1 1/2SM RA BR BKN011 BKN050 OVC060 11/11 A2956 RMK AO2 SFC VIS 3 TSB29E50 SLP008 VIS W-N 1 3/4 TS DSPTD P0016 T01110106 \$

In the remarks section, the observer has augmented a sector visibility (VIS W-N 1 3/4). ASOS does not now automatically report a sector visibility.

Example 5: Obstructions

a. SPECI KATY 080515Z AUTO 00000KT 1/4SM FZFG VV001 M23/M25 A3036 RMK AO2 FZRANO TSNO PNO

b. METAR KATY 080553Z AUTO 00000KT 1/4SM HZ VV001 M23/M26 A3036 RMK AO2 SLP326 6// // T12331261 11139 21239 410671239 58007 FZRANO TSNO PNO

c. METAR KATY 080653Z AUTO 00000KT 2 1/2SM BR OVC001 M23/M26 A3037 RMK AO2 SLP329 T12331256 FZRANO TSNO PNO

ASOS can automatically report the obscurations of fog (FG), freezing fog (FZFG), mist (BR), haze (HZ), and blowing snow (BLSN). Reporting these phenomena is based on surface (sensor) visibility, temperature, dew point depression, and the occurrence of precipitation. If there is precipitation, ASOS does not automatically report HZ or BLSN; however, it may report FG, FZFG, or BR during precipitation.

Looking at the three reports above, the obscuration changes from FZFG to HZ and then to BR. In the first report, the surface visibility is less than 5/8SM, the temperature is below 0°C, and the dew point depression is less than 4°F. Therefore FZFG is encoded. FZFG would also have been encoded if precipitation were occurring. In the second report, the dew point depression changes to 5°F (ambient temperature = -23.3°C and dew point temperature = -26.1°C) and the obscuration changes to HZ. If precipitation were occurring, HZ would not have been encoded. In the third report, the surface visibility increases to 2 1/2SM and dew point depression changes to 4°F (ambient temperature = -23.3°C and dew point temperature = -25.6°C). Therefore, BR is encoded as the obscuration. Note that no distinction is made between BR and freezing mist, as is done with FG and FZFG. Mist is reported as BR regardless of the temperature.

Example 6: Obstructions vs Visibility

a. SPECI KSP1 311245Z 31007KT 1/2SM BR 26/25 A3003 RMK AO2 SFC VIS 3 \$

b. SPECI KSP1 311247Z 31007KT 1/2SM FG 26/25 A3004 RMK AO2 TWR VIS 3 \$

In the first report of this example, the tower visibility is 1/2SM and the surface (sensor) visibility is 3SM. Determining surface obscuration is based on surface visibility, not tower visibility. In this case, note that BR is encoded as an obscuration. In the second report, we changed the surface visibility to 1/2SM and the tower visibility to 3SM. The obscuration correctly changed from BR to FG.

Since surface observations are taken at the surface, obscuration entries should accurately report conditions at the surface, not at the height of the tower cab. Both reports are correct as encoded.

Example 7: Obstructions vs. Surface Visibility

a. SPECI KSP1 041606Z 03013G22KT 2 1/2SM BR CLR 23/21 A3005 RMK AO2 TWR VIS 10 \$

b. SPECI KSP1 041608Z 36011G18KT 2 1/2SM CLR 23/21 A3004 RMK AO2 SFC VIS 10 \$

Because ASOS provides reports of surface conditions, algorithms that automatically encode obscurations, as well as the intensity of snow, use the surface (sensor) visibility as input. In the first report, the surface visibility is 2 1/2SM and the tower visibility is 10SM. In this case, ASOS automatically encoded mist (BR) as the obscuration. In the second report, the visibilities were changed to 10SM at the surface and 2 1/2SM from the tower cab. Since the surface visibility is now 10SM, ASOS does not encode an obscuration since it is not occurring at the surface. Both reports are correct as encoded.

Example 8: Variable Wind

- a. METAR KSP1 301756Z AUTO **33007KT 290V360** 10SM FEW049 19/M01 A2981 RMK AO2 SLP229 T01941006 10200 20122 58017 PWINO TSNO \$
- b. METAR KSP1 301856Z AUTO **VRB06G15KT** 10SM SCT050 19/M01 A2978 RMK AO2 SLP220 T01941011 PWINO TSNO \$
- c. SPECI KORE 291712Z AUTO **33003KT 6SM HZ** SCT014 BKN038 BKN049 11/07 A2965 RMK AO2 TSNO

Variable wind direction encoding is based on the observed sustained wind speed. When the wind has a sustained speed of greater than 6 knots, the variability of the wind's direction is encoded in the body of the report. (See the first report in this example.) When the sustained wind speed is 6 knots or less, a variable wind has an encoded direction of "VRB." As is shown in the second report of this example, the sustained wind speed is 6 knots but the wind is gusting to 15 knots. (Gusts are reported for a minimum of 10 minutes after they are first observed.) The direction is still encoded as "VRB." In the third report the winds are not variable and the actual direction is encoded.

Example 9: Surface Visibility and RVR, Plus Remarks

METAR KSP1 041156Z 05024G33KT 020V080 M1/4SM **R04/2800V5000FT** +SN FZFG VV002 M02/M02 A2953 RMK FUNNEL CLOUD B06 FUNNEL CLOUDE10 AO2 PK WND 04036/1135 **SFC VIS 1/4** SNB07 PRESFR SLP096 SNINCR 2/12 4/012 6//// 7//// T10201020 10167 21022 58199 PNO \$

At selected sites, Runway Visual Range (RVR) is encoded when conditions warrant. As shown above, RVR is encoded immediately after the visibility in the body of the report. RVR is encoded whenever surface visibility is one statute mile (1SM) or less, and/or if the minimum RVR value is less than or equal to 6,000 feet. In this case, surface visibility is 1/4SM (see remarks section).

This example also illustrates the order of remarks in an ASOS report. After the "RMK" (remarks) contraction, the following order is used:

1. Tornadic remarks: e.g., FUNNEL CLOUD B06 FUNNEL CLOUD E10
2. "AO2" indicator
3. Automated remarks: e.g., PK WND 04036/1135 SFC VIS 1/4 SNB07 PRESFR SLP096
4. Manual remarks: e.g., SNINCR 2/12 4/012
5. Additive data: 6//// 7//// T10201020 10167 21022 58199
6. Sensor status indicators: e.g., PNO
7. Maintenance check indicator: \$

Example 10: Surface Visibility and RVR

- a. SPECI KSP1 041202Z 35008KT M1/4SM BR CLR 18/18 RMK AO2 **SFC VIS 2** SNE02 PNO \$
- b. SPECI KSPI 041205Z 35008KT 340V070 **1/4SM** FG CLR 18/18 RMK AO2 TWR VIS 2 SNE02 RVRNO PNO \$

If for any reason the RVR should not be available from a site designated to report RVR, the remark RVRNO is encoded when the surface visibility is 1 statute mile or less. In the first report above, the surface visibility is 2SM. In the second report, the surface visibility reduces to 1/4SM and the RVRNO remark is encoded.

Example 11: Corrected Report

- a. METAR KSP1 081153Z 22006KT 9SM FEW250 M10/M13 A3015 RMK AO2 SLP259 T11001128 11094 21133 58006 **4/002**
- b. METAR KSP1 081153Z **COR** 22006KT 9SM FEW250 M10/M13 A3015 RMK AO2 SLP259 **4/002** T11001128 11094 21133 58006

This example illustrates the ASOS correction feature. Anyone signed-on as an observer can generate a corrected report. This feature allows the observer to enter data any place in the report. The observer is completely responsible for data quality and proper encoding practices. ASOS does not do any error checking in the correction feature. In the first report, the observer added the "4/sss" (snow depth on ground) group, however, it was not encoded in the proper order of entry. Using the ASOS correction feature allows the observer to correct data. In the second example a corrected report was issued with the "4/sss" group encoded in the proper location, between the "SLP259" and

“T11001128” group. Future enhancement to the ASOS QC algorithms will include format error checking when manual entries are made.

Example 12: Augmentation For Severe Present Weather

```
SPECI KSP1 241321Z 04008KT 7SM +FC -TSRA  
FEW035 BKN070 OVC090 31/20 A2964 RMK TOR-  
NADO B14 NE AO2 TSB21RAB21 P0000 $
```

This SPECI was generated to report the beginning of a thunderstorm (TS), which began at 1321Z. Note that a tornado (+FC) also is occurring and began at 1314Z. The observer added the +FC indicator in the body of the report and the direction (northeast - NE) from the station where the tornado was located when it began.

Example 13: Augmentation For Volcanic Eruption:

```
SPECI KSP1 241258Z 01007KT 300V040 3/4SM VA  
FEW050 BKN070 OVC095 10/M03 A2963 RMK AO2 VIS  
1/4V5 MT AUGUSTINE VOLCANO 70 MILES SW  
ERUPTED 241255 LARGE ASH CLOUD EXTENDING  
TO APRX 30000 FEET MOVING NE RVRNO $
```

When a volcanic eruption is first noted, a SPECI report is generated. Because there was volcanic ash (VA) at the site, the observer augmented the SPECI to report this obscuration. More information about the eruption was entered by the observer in the remarks section (shown in bold print).

5.4 Auxiliary Data

Auxiliary data consists of:

- Relative Humidity
- Sea-Level Pressure
- Station Pressure
- Density Altitude
- Pressure Altitude
- Magnetic Wind

These data are available on the VDU, user-provided video monitor screens and selected OID screens; they are updated every minute. The auxiliary data are generally derived from other processed sensor data by the weather reporting algorithms, and, therefore, cannot be edited directly, but may be altered indirectly by editing of the component parameters through the OID. Examples of auxiliary data displays are shown in Appendix A.

5.5 Standard Hydrometeorological Exchange Format (SHEF) Messages

In addition to METAR messages (which may contain precipitation accumulation remarks such as Prrrr, 6RRR/, and 7RRRR), ASOS also generates two distinct SHEF message types.

One type of message is in “.E” SHEF message format. This message is generated when precipitation accumulation criteria are exceeded and is discontinued when precipitation accumulation falls below the termination criteria. This type of message is referred to as the “SHEF 15-minute Precipitation Criteria Message.” This message contains a chronological listing of precipitation accumulation during the four most recent 15-minute reporting time periods. The 15-minute Precipitation Criteria Message is issued at either H+00, H+15, H+30, or H+45.

The second type of SHEF message is in “.A” SHEF format and is routinely generated at a fixed time each hour (H+00). This message is referred to as the “SHEF Hourly Routine Precipitation Message” and contains precipitation accumulation information for a 60-minute time interval ending at a fixed time each hour.

The onset and termination criteria for the SHEF 15-minute Precipitation Criteria Message and the end time for the SHEF Hourly Routine Precipitation Message are set during system acceptance. They may be subsequently changed only by an authorized ASOS system manager. SHEF messages are stored in ASOS memory for a minimum of 3 days plus so far for the current day. SHEF messages are available from all NWS and FAA ASOS locations.

All SHEF messages originating from NWS ASOS locations and transmitted on the NWS AFOS network are identified by the generic message header: “CCCNXX,” where NNN = RR6 (for the SHEF 15-minute Precipitation Criteria Message), or RR7 (for the SHEF Hourly Routine Precipitation Message). For NWS ASOS locations, CCC is the Station Identifier (SID) for the primary responsible WSFO/WFO, and XXX is the ASOS location’s SID. SHEF messages originating from NWS ASOS locations are transmitted individually.

Those SHEF messages originating from FAA ASOS locations are captured at the FAA WMSC (WMSCR in the future) and passed across Gateway to the NWS as collectives. These collectives are identified by the AFOS PIL header: “NMCRR7NKA.” Collectives contain both types of SHEF messages (RR6, RR7) from commissioned and pre-commissioned FAA ASOS locations.

Example I. SHEF 15-Minute Precipitation Criteria Message

MESSAGE NUMBER	TIME	ONSET CRITERIA	TERMINATION CRITERIA	PCPN VALUE
	1200 UTC	0.50 inch	0.25 inch	0.00 inch
	1215 UTC	0.50 inch	0.25 inch	0.25 inch
	1230 UTC	0.50 inch	0.25 inch	M
RR6 SHEF MSG #1	1245 UTC	0.50 inch	0.25 inch	0.75 inch
RR6 SHEF MSG #2	1300 UTC	0.50 inch	0.25 inch	0.25 inch
	1315 UTC	0.50 inch	0.25 inch	0.20 inch
<u>SHEF MSG #1:</u>				
TOPRR6TOP				
TTAA00 KTOP 201245				
.E TOP 1020 DH1200/PPC/DIN15/0.00/0.25/M/0.75: C = 0.50/.25				
<u>SHEF MSG #2:</u>				
TOPRR6TOP				
TTAA00 KTOP 201300				
.E TOP 1020 DH1215/PPC/DIN15/0.25/M/0.75/0.25: C = 0.50/.25				

Legend for Example I. (See SHEF Message #1)

.E TOP:	.E format message from Topeka, KS (TOP).
1020:	Month (October) and day (20) for first observation in time series (current year assumed).
DH1200:	Hour and minute UTC time stamp of first data value in time series. Example given here is 12:00 UTC.
PPC:	Precipitation, Actual Increment (PP); Fifteen minute increment (C).
DIN15:	DI = Data Interval; N15 = Fifteen Minutes.
/0.00/ /0.25/ /M/ /0.75:	Incremental precipitation (in inches) for first, second, third and fourth 15-minute periods of time series. Missing data are replaced with "M." The first value (0.00 inches) is valid for 12:00 UTC. The last value (0.75) is valid for 12:45 UTC.
C = n.nn/.tt	SHEF 15-minute onset threshold criteria/termination threshold criteria. In this example: n.nn = 0.50 inches, and .tt = .25 inches.

Distinctions between different SHEF message formats are also made in the body of the individual messages. See SHEF Version 1.1 issued by the NWS Office of Hydrology, 31 January 1985 for further details.

5.5.1 SHEF 15-Minute Precipitation Criteria Message

The messages in Example I are identified by the "RR6" in the AFOS header, the "E" message type designator and the "DIN15" 15-minute time interval indicator in the body of the message.

In Example I, MSG #1 was issued at 12:45 UTC because during the current 15-minute period (12:31 - 12:45 UTC) the precipitation accumulation first exceeded the 15-minute precipitation accumulation onset criteria of 0.50 inch. The three previous 15-minute time periods are also included in MSG#1 and listed in chronological order (even though precipitation accumulation during those time periods did not exceed the onset threshold criteria).

MSG #2 was issued at 13:00 UTC because precipitation accumulation during the immediately preceding 15-minute period (ending at 12:45 UTC) exceeded the onset threshold criteria and the precipitation accumulation during the current 15-minute period (12:46 - 13:00 UTC) is still equal to or greater than the termination criteria of 0.25 inch. 15-Minute Precipitation Criteria Messages cease to be issued when the discrete 15-minute precipitation accumulation falls below the termination threshold criteria. If precipitation accumulation is missing during any minute within a discrete 15-period, then the value reported for that 15-minute period is "M."

5.5.2 SHEF Hourly Routine Precipitation Message

The messages in Example II are identified by the "RR7" in the AFOS header, and the ".A" SHEF format designator in the body of the message. In example II the end time of the SHEF Hourly Routine Precipitation Message is set at H+00. Thus, all precipitation accumulation reports in example II are for the 60-minute period from H+01 to H+00. A SHEF Hourly Routine Precipitation Message is issued routinely every hour, regardless of whether or not there was precipitation during the hour.

SHEF MSG #3 is valid at 1400 UTC. This 60-minute period includes the 0.20 inch precipitation accumulation which occurred during the 15-minute period ending at 1315

UTC. Note that the detection threshold specified for the ASOS HTB is 0.01 inch per hour, and the precipitation rate accuracy is the larger of 10 percent or 0.01 inches per hour.

SHEF MSG #4 shows a large 60-minute accumulation of 1.35 inches ending at 1500 UTC.

SHEF MSG #5 valid at 1600 UTC is a typical example of a 60-minute reporting period with no measurable precipitation.

SHEF MSG #6 valid at 1700 UTC is a typical example of a 60-minute reporting period where some of the 1-minute data were missing. If precipitation accumulation is missing during any minute within the discrete 60-minute period, then the value reported in the SHEF Hourly Routine Precipitation message after "PPH" is "M."

5.6 Daily and Monthly Summaries

All ASOS locations are capable of generating and transmitting daily and monthly weather summaries, however, only selected NWS ASOS locations transmit these data long-line. These summaries are valid for the calendar day, or the calendar month, ending at 23:59 LST. The daily summaries are normally transmitted early on the following day at a programmable transmission time specified by the system manager. Backup transmission times are generally 1 and 2 hours after the initial scheduled transmission time. The monthly summaries are normally transmitted early on the first day of the new month at programmable transmission times. Backup transmission times are generally 1 and 2 hours after the initial scheduled transmission time. The ASOS generated daily and monthly summaries replace the "F-6" data previously provided from staffed locations.

Daily and monthly summaries are stored in ASOS memory for 10 days after transmission. The content and format of the daily and monthly summary messages is only briefly summarized here.

5.6.1 Daily Summary Message

The Daily Summary Message (DSM) contains data to complete the Preliminary Local Climatic Data (PLCD) record for each specified location. These data are valid for the previous day and include:

Example II. SHEF Hourly Routine Precipitation Message

MESSAGE NUMBER	TIME	PCPN VALUE
RR7 SHEF MSG #3	1400 UTC	0.20 inch
RR7 SHEF MSG #4	1500 UTC	1.35 inch
RR7 SHEF MSG #5	1600 UTC	0.00 inch
RR7 SHEF MSG #6	1700 UTC	Missing
SHEF MSG #3:	TOPRR7TOP TTAA00 KTOP 201400 .A TOP 1020 DH1400/PPH 0.20	
SHEF MSG #4:	TOPRR7TOP TTAA00 KTOP 201500 .A TOP 1020 DH1500/PPH 1.35	
SHEF MSG #5:	TOPRR7TOP TTAA00 KTOP 201600 .A TOP 1020 DH1600/PPH 0.00	
SHEF MSG #6:	TOPRR7TOP TTAA00 KTOP 201700 A TOP 1020 DH1700/PPH M	

Legend for Example II. (See SHEF MSG #3)

.A TOP:	“.A” format message from Topeka, KS (TOP).
1020:	Month (October), and day (20) of observation (current year assumed).
DH1400:	Observation time in UTC. Example given here is for MSG # 3 (14:00 UTC).
PPH:	Precipitation, Actual Increment (PP); Hourly increment (H).
0.20 (a.aa):	Incremental precipitation is in hundredths of an inch. In the example given here, precipitation accumulation for the current hour in MSG # 3 (ending at 14:00 UTC) is 0.20 inch

- Daily (00:00 to 23:59 LST) Maximum/ Minimum Temperatures and Times of Occurrence
- Daytime (0700 to 1900 LST) Maximum Temperature and Time of Occurrence
- Nighttime (1900 to 0800 LST) Minimum Temperature and Time of Occurrence
- Daily Minimum Sea-Level Pressure
- Daily Total Precipitation Accumulation (Liquid Equivalent)
- Hourly Precipitation Amounts (H+00 to H+59)
- Daily Average 2-Minute Wind Speed
- Fastest 2-Minute Wind Direction, Speed (MPH) and Time of Occurrence
- Daily Peak Wind Direction and Speed (MPH) and Time of Occurrence
- Weather Occurrence Symbols
- Minutes of Sunshine and Percentage of Sunshine **(When Available)**
- Daily Total Snowfall, Ice Pellets Accumulation **(When Available)**
- Depth of Snow, Ice and/or Ice Pellets on the Ground (In Whole Inches) at a Designated Observation Time **(When Available)**
- Average Daylight Sky Cover (Sunrise to Sunset) **(When Available)**
- Average Daily Sky Cover **(When Available)**
- Remarks for Estimated Data
- Number of Days with Minimum Temperature of 32°F and Below.
- Number of Days with Minimum Temperature of 0°F and Below.
- Monthly Heating Degree Days
- Monthly Cooling Degree Days
- Monthly Mean Station Pressure
- Monthly Mean Sea-Level Pressure
- Monthly Maximum Sea-Level Pressure and Date and Time of Occurrence
- Monthly Minimum Sea-Level Pressure (Nearest 0.01 Inch Hg) and Date and Time of Occurrence
- Monthly Total Precipitation (Water Equivalent)
- Number of Days with Precipitation Greater Than or equal to 0.01, 0.10, 0.50, and 1.00 inch
- Greatest 24-Hour Precipitation (Water Equivalent) and Date(s) of Occurrence
- Short Duration Precipitation (5, 10, 15, 20, 30, 45, 60, 80, 100, 120, 150, 180 min) including Date of Occurrence and Time when period ended
- Monthly Total Hours of Sunshine Observed **(When Available)**
- Monthly Percentage of Total Sunshine Observed **(When Available)**
- Greatest 24-Hour Snowfall and Date(s) of Occurrence **(When Available)**
- Greatest Depth Of Snow on Ground and Date(s) of Occurrence **(When Available)**
- Number of Clear, Partly Cloudy, and Cloudy Days during Month **(When Available)**
- Remarks For Estimated Data

5.6.2 Monthly Summary Message

The Monthly Summary Message (MSM) contains data necessary to complete the monthly Preliminary Local Climatic Data (PLCD) record for each specified location. These data are valid for the previous calendar month and include:

- Monthly Maximum Temperature and Date of Occurrence
- Monthly Minimum Temperature and Date of Occurrence
- Average Daily Maximum Temperature
- Average Daily Minimum Temperature
- Average Monthly Temperature
- Number of Days with Maximum Temperature of 32°F and Below
- Number of Days with Maximum Temperature of 90°F and Above (Use 70°F in NWS Alaska Region)

5.7 ASOS High-Resolution Sensor Data

High-resolution sensor data from the ASOS 12-hour archive file are available for review at the ASOS OID or to authorized remote users. These data have not undergone final quality control checks. They are primarily intended for maintenance troubleshooting purposes and should not be used as valid meteorological data without extensive evaluation. The high-resolution data which are available for review are summarized in Table 9. Examples of ASOS 1-Minute Sensor Data are shown in Appendix A.

Table 9. ASOS High-Resolution Data

- 30-Second Cloud Height Reading (Ceilometer Data)
- 1-Minute Average Visibility Extinction Coefficient
- 1-Minute Photometer Reading
- 1-Minute Average Ambient Temperature
- 1-Minute Average Dew Point Temperature
- 2-Minute Average Wind Speed and Direction (Every Minute)
- Maximum 5-Second Average Wind Speed and Direction For Each Minute
- 1-Minute Precipitation Identification Sensor Data
- 1-Minute Lightning Data *
- 1-Minute Precipitation Amount
- 15-Minute Incremental Precipitation Amount Stored Every 15 Minutes
- 1-Minute Sunshine Data *
- 1-Minute Frozen Precipitation Water Equivalent *
- 1-Minute Snow Depth *
- 1-Minute Freezing Rain Occurrence
- 1-Minute Average Pressure For Each Pressure Cell

* When Sensors Become Available

CHAPTER SIX

6.0 ASOS Data Outlets

ASOS data are provided through multiple data outlets. There are five basic types of ASOS data outlets. The basic ASOS data outlets are described below along with a brief description of the types of data available through each of these outlets. The basic ASOS data outlets are:

- On-Site and Remote OID Video Screen Displays, and Remote User Interactive Video Screen Displays
- On-Site, Non-Interactive Screen Displays
- On-Site Printer Hard copy
- Long-Line Coded Messages
- Computer-Generated Voice Messages

6.1 Interactive Video Screen Displays

At staffed ASOS locations, up to two Operator Interface Devices (OID) can be provided. The OID consists of a monitor and keyboard and provides interactive access to ASOS data through the ACU. A primary OID is located at the designated primary observer location. At airports with air traffic control towers, an OID is also provided which may be designated either the primary or secondary OID, depending upon primary observer location. On-site users may "sign-on" to the ASOS OID in any one of four access levels with the proper password. Those four levels include:

- Observer Level
- Air Traffic Control (Tower) Level
- Technician Level
- System Manager Level

OID users in both the Observer Level and the Air Traffic Control Level can be signed on to the ASOS simultaneously, however no two users can be signed on in the Observer Level at the same time. Remote OID users and remote interactive computer users may only sign on as:

- Unsigned User
- Technician
- System Manager

Up to 8 on-site OID/remote OID users may be signed-on at one time, however, only one on-site OID user at a time may be signed-on in the (primary) Observer Level or Air Traffic Control (ATC) Level. It is not possible to remotely sign-on in the Observer level or ATC level. This

prevents remote editing or augmenting of the ASOS data. The various types of data available in these sign-on levels are listed in Figure 4, and shown in Appendix A, ASOS Video Displays.

6.2 Non-Interactive Screen Displays

On-site displays, other than the OID, include the FAA ACE Video Display (VD) and the Video Display Unit (VDU). The VD is intended for Air Traffic Controller use. The VDU (up to 4 per airport) is intended for observer use at the primary observation location. Other users, such as fixed base operators, may interface with the ASOS by providing their own off-the-shelf, non-interactive video monitors. Up to 50 such monitors can be interfaced with ASOS at a single airport. The data which may be displayed on these monitors is identical to the data displayed on the VDU. See Appendix I for examples of the FAA VD and VDU screens.

The FAA VD includes the 5-second wind update of the current 2-minute average wind (magnetic), the current 1-minute update of the altimeter setting, the last transmitted METAR, and the density altitude at the time of the last transmitted METAR. This data is automatically updated by the ASOS.

The VDU displays the most current OMO data, the last transmitted METAR, and auxiliary data such as Relative Humidity, Sea-Level Pressure, Density Altitude, Pressure Altitude, and wind (direction given in both magnetic and true degrees). Most auxiliary data are refreshed automatically once every minute (see Section 5.4 for details). The data available on the user provided monitor is identical with that provided on the VDU. No user interaction with ASOS is permitted with the FAA VD, VDU, or user provided monitor.

6.3 ASOS Printer

One printer may be provided at the primary OID equipped location. The following data are automatically printed:

- All transmitted METARs

- Equipment failures
- Daily and monthly summaries (after computed)

In addition, any data displayed on the primary OID screen may be printed upon command.

6.4 Long-Line Dissemination

The ASOS coded messages are transmitted nationwide through NWS and FAA communication networks (see Figures 18 and 19).

Initially, the FAA will provide OMO data for local use only; no networking of these data is possible. Additionally, all ASOS METAR messages are available to users on both the FAA and NWS networks. Exchange of ASOS METAR messages between the FAA and NWS communications networks occurs through the NWS Telecommunication Gateway (NWSTG). ASOS METAR messages, SHEF data, and Daily Summary and Monthly Summary Messages from both FAA and NWS locations are additionally available to other users through the NWSTG.

In the final network configuration, OMO data from all ASOS locations will be made available to users upon request. OMO data from specified ASOS locations will be provided to the NWS Weather Forecast Offices (WFO), upon request, once every 5 minutes when the WFO is operating in the "warning" mode, or once every 15 minutes when the WFO is operating in the "alert" mode.

6.5 Computer-Generated Voice Messages

ASOS computer-generated voice messages include those which are broadcast directly to pilots through the ASOS ground-to-air radio, and those which are made available to the general aviation public through FAA sponsored telephone dial-in access. The information contained in the ground-to-air radio message and the telephone dial-in message are identical. ASOS computer-generated voice observations are spoken at the rate of 100 words per-minute.

The content of the computer-generated voice message is either the current OMO or the current METAR, depending on location. At unstaffed locations, the OMO is used; at FAA towered locations the OMO or METAR may be used at the discretion of the air traffic controller. The content of the computer-generated voice includes the following:

- Location identification
- Type of observing station (automated), but not type of observation (i.e., METAR or SPECI)
- The valid time of the observation
- The individual reported weather elements normally included in the METAR (except sea-level pressure). One major difference from the METAR however, is that wind direction in the voice message is given in reference to *magnetic* direction instead of true direction
- Selected automated remarks and manual OID keyboard entered remarks

After the altimeter setting information is given, the word "remarks" is spoken to indicate that additional information follows. This additional information may be ASOS generated and/or manually entered. The ASOS is capable of selecting appropriate words from the approved ASOS voice vocabulary (see Appendix D) and producing computer-generated voice remarks for:

- Variable visibility (e.g., "visibility two miles variable three miles")
- Pressure (e.g., when density altitude is $\geq 1,000$ feet an automated remark is generated; "Density altitude two thousand five hundred")
- Lightning (e.g., "Lightning Distant Northeast")

Manually generated remarks are appended to the computer-generated voice remarks through the OID keyboard. For example, manual entry remarks through the OID keyboard may include tower-visibility.

At towered airports, the air traffic controller has the option of selecting for the broadcast weather message either METARs (scheduled or unscheduled) or OMOs. At non-towered locations, the broadcast weather message defaults to the OMO.

Each computer-generated voice message begins with an identification of the location, the phrase "AUTOMATED WEATHER OBSERVATION" and the UTC (ZULU) time of the observation.

To clarify and distinguish the different data elements in the computer-generated voice message a verbal identifier (prefix) accompanies each weather element (e.g., "temperature four dew point three"). Weather elements missing in the METAR or OMO alpha-numeric message are enunciated as "missing" in the corresponding computer-generated voice message (e.g., "sky condition missing," "visibility missing").

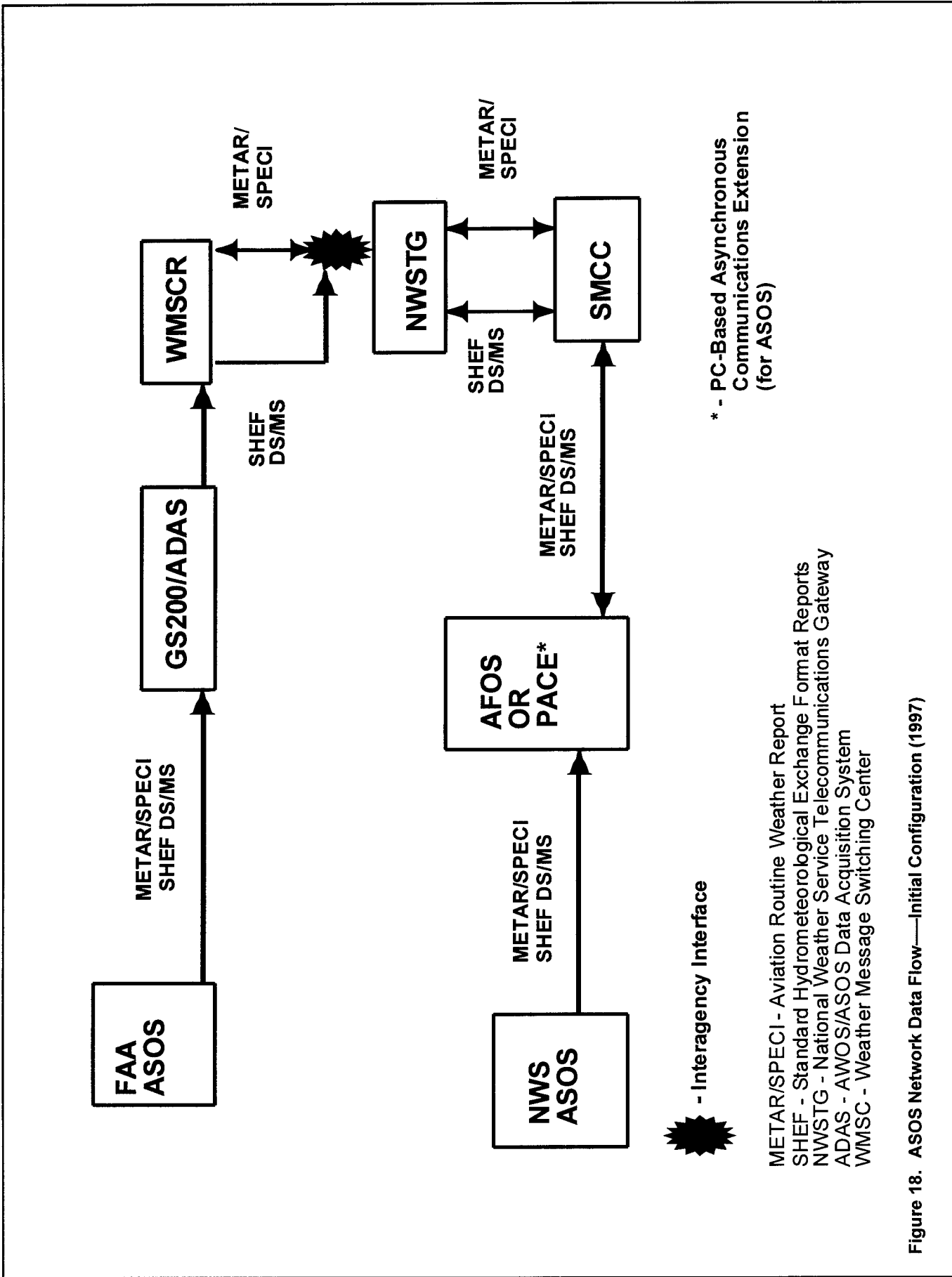
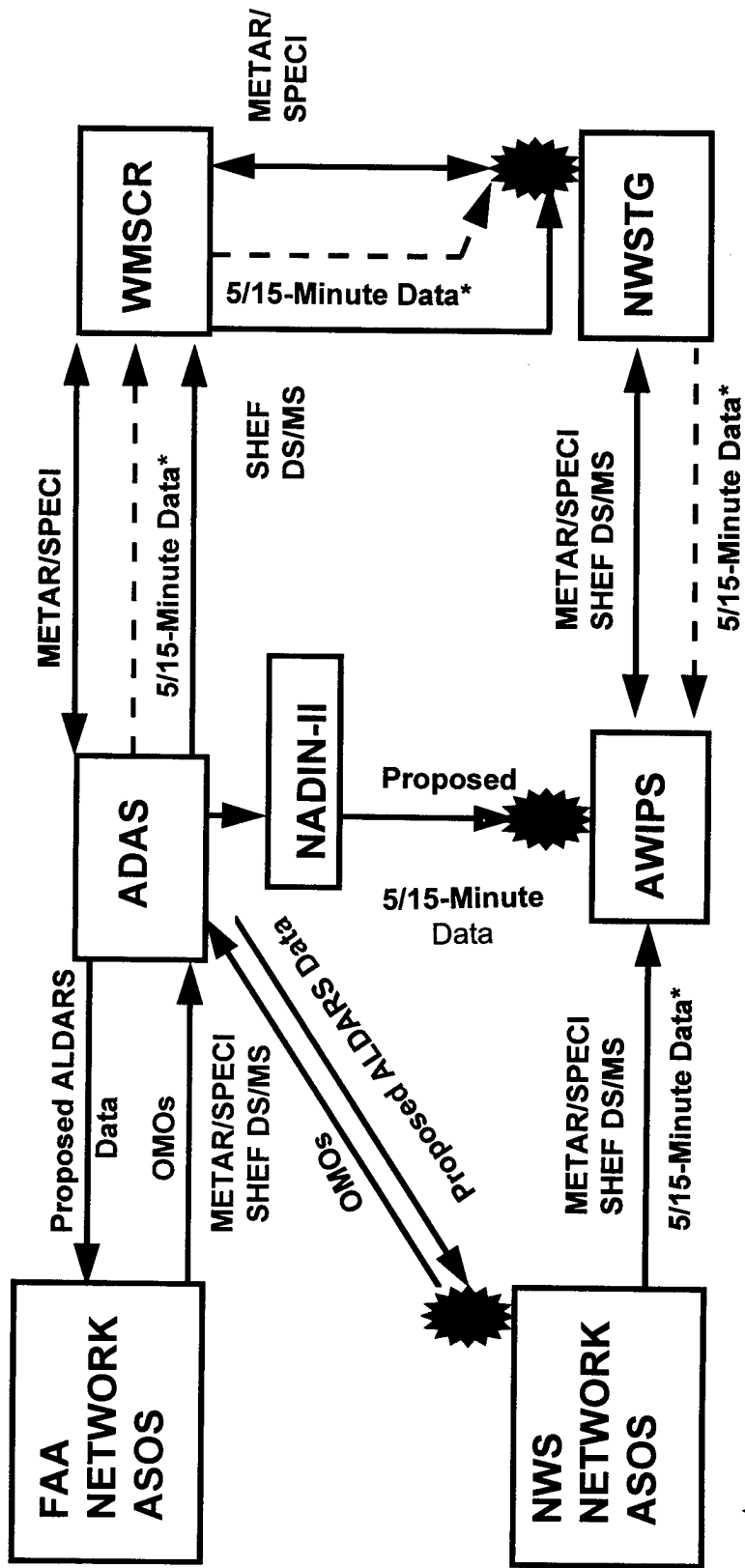

Figure 18. ASOS Network Data Flow—Initial Configuration (1997)



* - Alternate proposal for delivery of the 5/15-minute data from FAA to AWIPS

- Interagency Interface

- METAR/SPECI - Aviation Routine Weather Report
- SHEF - Standard Hydrometeorological Exchange Format Reports
- OMOs - One Minute Observations
- DS/MS - Daily Summary/Monthly Summary Messages
- WMSCR - Weather Message Switching Center Replacement
- ALDARS - Automated Lightning Detection and Reporting System

Figure 19. ASOS Network Data Flow—Final Configuration

ated voice message (e.g., “sky condition missing,” “visibility missing”).

Example 1

If the airport’s specific location is included in the airport’s name, the airport’s name is announced.

“BREMERTON NATIONAL AIRPORT, AUTOMATED WEATHER OBSERVATION, ONE FOUR FIVE SIX ZULU, ...”

“RAVENSWORTH JACKSON COUNTY AIRPORT, AUTOMATED WEATHER OBSERVATION, ONE FOUR FIVE SIX ZULU, ...”

Example 2

If the airport’s specific location is not included in the airport’s name, the location name is first announced, and then the airport name is given.

“SAULT STE MARIE, CHIPPEWA COUNTY INTERNATIONAL AIRPORT, AUTOMATED WEATHER OBSERVATION, ONE FOUR FIVE SIX ZULU, ...”

“SANDUSKY, COWLEY FIELD, AUTOMATED WEATHER OBSERVATION, ONE FOUR FIVE SIX ZULU, ...”

Example 3

During the nationwide implementation of the ASOS, each location will operate in test mode for approximately 30-60 days before commissioning. A longer period of test broadcasts may occur at selected locations. During this test period, computer-generated voice messages will have the word “TEST” in the message following the word “OBSERVATION” to indicate that the observation is not official.

“BREMERTON NATIONAL AIRPORT AUTOMATED WEATHER OBSERVATION TEST ONE FOUR FIVE SIX ZULU, ...”

Example 4

The phrase “TEMPORARILY INACTIVE” is added to the message after the word “OBSERVATION” to indicate that the system is inoperative.

“BREMERTON NATIONAL AIRPORT, AUTOMATED WEATHER OBSERVATION, TEMPORARILY INACTIVE, ONE FOUR FIVE SIX ZULU, ...”

Example 5

In this example, a “clear below 12,000 feet” observation is given. Notice that the number “9” is pronounced NINER. The magnetic declination at MHK is 7°E. The true wind direction reported in the METAR (280 degrees) is reported as 270 degrees magnetic (rounded to the nearest 10 degrees) in the computer-generated voice message.

METAR KMHK 010355Z AUTO 28008KT 10SM CLR 20/13 A2988 RMK AO2 SLP929 T02000130

“MANHATTAN MUNICIPAL AIRPORT, AUTOMATED WEATHER OBSERVATION, ZERO THREE FIVE FIVE ZULU, WIND TWO SEVEN ZERO AT ZERO EIGHT, VISIBILITY ONE ZERO, SKY CONDITION CLEAR, TEMPERATURE TWO ZERO CELSIUS, DEW POINT ONE THREE CELSIUS, ALTIMETER TWO NINER EIGHT EIGHT”

Example 6

In this example, a manual lower tower visibility is given. The measured true wind direction is 164 degrees (rounded to 160 for reporting in the METAR). The measured magnetic wind direction is 157 degrees (rounded to 160 degrees for reporting in the computer-generated voice message). Although magnetic declination at MHK is 7°E, note that both the true and magnetic wind directions are reported as 160 degrees in this example.

SPECI KMHK AUTO 090735Z 16005KT 1SM -RA BR OVC050 20/20 A2992 RMK AO2 SFC VIS 3 P0001

“MANHATTAN MUNICIPAL AIRPORT, AUTOMATED WEATHER OBSERVATION, ZERO SEVEN THREE FIVE ZULU, WIND ONE SIX ZERO AT ZERO FIVE, VISIBILITY ONE, LIGHT RAIN MIST, SKY CONDITION OVERCAST FIVE THOUSAND, TEMPERATURE TWO ZERO CELSIUS, DEW POINT TWO ZERO CELSIUS, ALTIMETER TWO NINER NINER TWO, REMARKS SURFACE VISIBILITY THREE”

Example 7

ASOS does not report a cloud height of zero, but is capable of reporting a vertical visibility with an obscura-

tion. Observed visibilities of zero, 1/16 or 1/8 mile are all reported as "less than one quarter" mile by ASOS but may be manually augmented. The pressure sensors are inoperative and therefore the altimeter is missing (note the "\$" maintenance flag in the METAR message). The magnetic declination at ABI is 8°E. With a calm wind however, both the true wind direction in the METAR (00000) and the magnetic wind direction in the computer-generated message are reported as "calm."

SPECI KABI 121255Z AUTO 0000KT M1/4SM FG
VV001 16/16 RMK AO2 \$

"ABILENE MUNICIPAL AIRPORT, AUTOMATED WEATHER OBSERVATION, ONE TWO FIVE FIVE ZULU, WIND CALM, VISIBILITY LESS THAN ONE QUARTER, FOG, VERTICAL VISIBILITY ONE HUNDRED FEET, TEMPERATURE ONE SIX CELSIUS, DEW POINT ONE SIX CELSIUS, ALTIMETER MISSING"

Example 8

In this example, variable visibility is automatically included as a remark. The magnetic declination at BUF is 8°W. The computed true wind direction (rounded to the nearest degree) is 237 degrees, and the computed magnetic wind direction (also rounded to the nearest degree) is 245 degrees. For reporting purposes, wind directions are rounded down to the nearest 10 degrees. Thus the true direction reported in the METAR is given as 240 degrees while the magnetic direction reported in the computer-generated voice message is also given as 240 degrees.

SPECI KBUF 111541 AUTO 24010 11/2SM -SN SCT010
OVC018 M02/M03 A2955 RMK AO2 VIS 1V2

"GREATER BUFFALO AIRPORT, AUTOMATED WEATHER OBSERVATION, ONE FIVE FOUR ONE ZULU, WIND TWO FOUR ZERO AT ONE ZERO, VISIBILITY ONE AND ONE HALF, LIGHT SNOW, SKY CONDITION SCATTERED AT ONE THOUSAND OVERCAST AT ONE THOUSAND EIGHT HUNDRED, TEMPERATURE MINUS ZERO TWO, DEW POINT MINUS ZERO THREE, ALTIMETER TWO NINER FIVE FIVE, REMARKS VISIBILITY ONE VARIABLE TWO"

CHAPTER SEVEN

7.0 Introduction

This chapter lists elements ASOS does not now provide and describes plans for product improvement.

7.1 Data Not Provided by ASOS

The elements not currently sensed or reported by ASOS are listed in Table 10. Other complementary technology or supplementary observing networks will report these weather conditions. Some additional data may be added to the ASOS report through augmentation. Data from separate observing networks or from remote sensing technologies such as WSR-88D, GOES, and LDS can be used to complement the sensor observation provided by ASOS.

The operational implementation of ASOS is clearly a major technological achievement in automation of surface observations. As with any new sophisticated technology, continuous development and product improvement are essential to keep pace with an ever changing world. The ASOS product improvement program is an on-going effort to enhance existing capabilities and develop new sensors and/or algorithms for reporting hail, snowfall, liquid equivalent of frozen precipitation, and snow accumulation. Work continues on incorporating independent ALS and NLDN-ALDARS data into the ASOS to provide real-time information on thunderstorm location.

7.2 Planned Product Improvement

The development and fielding of the ASOS network represents a large initial commitment of time and tax dollars. The goal of ASOS planned product improvements is to ensure the most cost-effective benefits to the nation well into the next century, to prevent premature system obsolescence and the need for a costly full system replacement, and to more adequately meet changing user requirements and decrease maintenance demands. To meet this goal, the NWS has initiated a long-term product improvement program.

The objectives of this multi-year program are to refine and improve the ASOS baseline suite, while taking advantage of future scientific and technical breakthroughs in sensors and algorithms which will enhance and expand the

Table 10. Weather Elements Not Reported by ASOS

■ Tornado, funnel cloud, waterspout ^b
■ Hail ^{abc}
■ Ice crystals ^a [Snow grains, Ice Pellets, Snow pellets] ^{abc}
■ Drizzle, freezing drizzle ^{abc}
■ Volcanic ash ^b
■ Blowing obstructions (sand, dust, spray) ^{abc}
■ Smoke ^b
■ Snow fall (accumulation rate) and snow depth (6-hourly) ^{abc}
■ Hourly snow increase (SNINCR) remarks ^{abc}
■ Liquid Equivalent of Frozen Precipitation ^{abc}
■ Water equivalent of snow on the ground ^{ac}
■ Clouds above 12,000 feet ^{abcd}
■ Operationally significant clouds above 12,000 feet in mountainous areas ^b
■ Virga ^b
■ Distant precipitation in mountainous areas and distant clouds obscuring mountains ^b
■ Operationally significant local variations in visibility ^b
■ Minutes of sunshine ^c

a = Provided by supplementary observing networks
b = May be provided by manual augmentation
c = May be provided by future ASOS sensors/algorithms
d = Provided by complementary technologies (Satellite Cloud Product, ALDARS, etc.)

baseline capabilities. The current ASOS baseline includes reports for the following elements: Wind, Visibility, Present Weather/Obscurements, Ambient Temperature/Dew Point Temperature, Altimeter Setting (Pressure), and Liquid Precipitation Accumulation.

Typically, several years of test and evaluation activities are required before a new sensor is ready for implementation. The process begins by first defining the operational and performance requirements that a potential sensor must meet, defining the specification, and then selecting a number of vendors from which to procure suitable prototypes. These prototypes are generally tested and evaluated over at least a two year period in selected environments to ensure that the sensors are subjected to a full spectrum of weather conditions.

An iterative process of refining the hardware and software capabilities occurs during this period. Evaluation results and requests for specific changes are continuously sent to the vendors. As potential technology improvements become available, they are incorporated into the prototype sensors for further testing.

The most promising prototype sensors, usually from one vendor, are then integrated into the operational ASOS sensor suite and tested at approximately 20 sites for another year or two. This procedure enables test and evaluation to occur in a more realistic setting and under more varied weather conditions. It also helps to ensure that the hardware/software components of the new sensor are compatible with those of the existing ASOS sensor suite.

The iterative process of sensor refinement continues as the vendor receives evaluation data and requests for changes. At this stage, the evaluation process includes feedback from potential users, made possible by the more operational setting. After evaluation and filtering of user feedback comments, recommendations for improvement are forwarded to the vendor. Again, as sensor improvements become available, they are incorporated into the prototype sensors for further testing. Upon successful completion of this process, a new sensor/capability is added to the ASOS nationwide network. The following sections describe specific product improvement activities.

7.2.1 Ice-Free Wind Sensor

The current ASOS wind sensor uses the traditional cup and vane design that occasionally experiences freeze-up in icing conditions. To minimize these occurrences, the ASOS Program Office is testing a variety of replacement wind sensors with respect to the ability to continue operation under adverse winter conditions such as freezing rain, freezing drizzle, and snow. First-year testing started during the fall of 1995 with ice-free wind sensors from four vendors. Second-year testing (field, chamber, and wind tunnel) started in December 1996 and is ongoing as of this writing.

7.2.2 Dew Point Sensor

The current ASOS dew point sensor exhibits several problems, including corrosion and calibration problems, resulting in inaccurate and unreliable performance of the sensor. Consequently, ASOS technicians make more frequent periodic maintenance trips than the ASOS specified 90-day preventive maintenance interval. Several modifications have been made, and continue to be made, to the existing dew point sensor. One improvement is the replace-

ment of the silver coated mirror with a gold coated mirror. This increases the mirror's reflectivity and the sensor's ability to compensate for mirror contamination over a longer period of time before maintenance is needed. An effort is now underway to completely replace the chilled mirror dew point sensor with an alternative technology.

An alternative vendor/technology search was conducted in Spring 1996 and revealed five potential alternative sensor technologies:

- Chilled surface-capacitive
- Infrared hygrometer
- Hygro-mechanical arch
- Lithium chloride
- Thin-film capacitive

Based on analysis of the competing technologies, the thin-film capacitive technology was selected for testing. Initial testing began at four test locations in 1997.

7.2.3 Ceilometer/Sky Condition

The ASOS specification requires the ceilometer to report cloud heights up to 12,000 feet. Under most circumstances, the sky condition algorithm processes the cloud height information properly. The resultant sky condition report is fairly representative of the actual sky condition near the airport. However, the algorithm can be improved to enhance reporting of cloud bases and vertical visibility during fog, virga, and precipitation events. Algorithm improvements are also needed to reduce the false reporting of lower mid-level moisture layers as clouds.

The ASOS Program can and will make some of the proposed algorithm enhancements using the current ceilometer. Laser beam ceilometer technology employed in the current model has advanced in recent years to provide improved cloud base detection. In addition, new generation cloud height sensors (e.g., 25,000 foot ceilometers) may provide more reliable information in the lower atmosphere during adverse weather conditions. Initial testing of the 25,000 foot ceilometers from three vendors started in August 1996.

7.2.4 All-Weather Precipitation Accumulation Gauge

The current ASOS Heated Tipping Bucket gauge is strictly a liquid precipitation accumulation sensor. A Frozen Precipitation Water Equivalent Sensor was a planned addition to ASOS. Numerous attempts were made to design a suitable frozen precipitation water equivalent sen-

sor. These sensors typically consisted of a collection bucket mounted on a load cell. The basic problem was that the load cell exhibited too much hysteresis with temperature. In June 1996, the NWS Offices of Hydrology and Meteorology finalized a requirement for an "all-weather" gauge that will measure both liquid and frozen precipitation water equivalent. Initial testing of all-weather precipitation accumulation gauges (AWPAG) from two vendors started in January 1997. The AWPAG requirement was modified in Spring 1997 based on initial test results. Follow-on testing is planned for 1998.

7.2.5 Enhanced Precipitation Identification

The current precipitation identification sensor does not consistently detect and report light precipitation (< 0.01 inch/hour), ice pellets, or hail. The current precipitation identification sensor was designed to meet a requirement to detect precipitation that falls at a rate ≥ 0.01 inch/hour. ASOS's existing precipitation identification sensor can detect rain or snow; however, the sensor identifies ice pellets and hail as rain, or undetermined precipitation (UP). Field reports have identified a resurgent need for the detection and identification of drizzle or very light precipitation (< 0.01 inch/hour), ice pellets, and hail. Finally, although the first generation algorithms for blowing snow are now part of ASOS, further development and refinement is being pursued. Initial sensor testing from two vendors started during 1995-1996 winter. A single vendor's technology was tested during 1997.

7.2.6 Sunshine

The ASOS specification has a requirement for a sunshine sensor. Test and evaluation of candidate sensors began in 1992. The sunshine sensors from test vendors were tested and evaluated. All candidates' sensors were compared with two reference sensors, the Foster-Foskett and the Eppley pyrliometer. Test results revealed that one vendor was clearly superior in meeting the ASOS specification. In 1995, the Office of Meteorology redefined the ASOS specification for the sunshine sensor. Sunshine sensors from the leading vendor were installed at four test sites in early 1996. A one-two year demonstration began at eight other sites in Summer 1997.

7.2.7 Schedule

The earliest product improvement sensor forecasted to reach production is the sunshine sensor. It is expected to

be fielded as early as FY 1999. Limited production and field implementation of other sensors/algorithms is estimated to start in the year 2000 and be completed by 2007.

7.3 Summary

The characteristics of the ASOS include:

- Continuous Operation; Reports Updated Every Minute
- Fast Response to Changing Conditions
- Consistency of Observations
- Designed for Aviation Operational Use
- Critical Sensors Normally Located Near TDZ
- Visibility Determinations to 10 Miles
- Cloud Height Determination Up to 12,000 Feet
- Present Weather Sensors Included
- Multiple Sensors Where Needed

Among the basic strengths of the ASOS observation is the ability to measure critical weather parameters (such as sky condition and visibility) where they are needed most—at the touchdown zone(s). Other parameters may be measured at a representative location, usually near the center of the airport. ASOS data are updated once each minute and transmitted directly to the air traffic controller. ASOS generated METAR messages, SHEF messages, and daily and monthly summary products are routinely made available for nationwide dissemination. The ASOS is capable of performing all the basic observing functions and operating fully unattended, thus freeing observing personnel for other demanding duties.

ASOS data may be accessed through a variety of media never before available from a surface observing site. Various local on-site video screen displays are available on the OID (proper access code/password may be required), and VDU. Remote monitor hook-up can be made available to airlines and other external users on the airport. Authorized remote users (with modem-equipped computers and the proper access code/password) may also acquire a wide variety of OID screen displays through the ASOS remote user dial-in port. Computer-generated voice messages are made available to local aviation users through ground-to-air broadcast and a dial-in telephone number provided at each ASOS location. Long-line users are provided with routine access to ASOS generated METAR and SHEF messages, and daily and monthly summary data. The wealth of high-quality ASOS data now available to users provides new resources and exciting opportunities in meeting future needs for environmental data.

APPENDIX A

**ASOS Video
Screens**

EXAMPLE OF THE VDU SCREEN

09:35:17	08/12/97	HOME TOWN AIRPORT	
SKY	BKN075		
VSBY	21/2SM	TWR VSBY	3SM
PREWX	HZ	SEA PRES	1024.7
TEMP/DP	20/17 C	REL HUM	43
WIND	090/07 040V120	MAG WIND	110/07 070V140
ALT SET	30.15 DEN ALT 1000	PRES ALT	320
REMARKS RMK AO2 TWR VIS 3 VIS 13/4V4			
SPECI KXXX 121220Z 09007KT 040V120 2 1/2SM HZ BKN075 20/17 A3015			
RMK AO2 TWR VIS 3 VIS 1 3/4V4			

EXAMPLE OF THE OID REVIEW OBSERVATION (METAR/SPECI) SCREEN

08:47:19 08/12/97 1347Z	HOME TOWN AIRPORT	
08/12/97 04:22:18 SPECI KXXX 120916Z AUTO 33004KT 4SM BR FEW001 19/19 A3011 RMK AO2		
08/12/97 05:02:23 METAR KXXX 120956Z AUTO 00000KT 5SM BR BKN075 20/19 A3013 RMK AO2 SLP197 T02000194		
08/12/97 06:02:42 METAR KXXX 121056Z AUTO 00000KT 3SM BR CLR 21/21 A3014 RMK AO2 SLP201 T02060206		
08/12/97 06:13:15 SPECI KXXX 121108Z AUTO 00000KT 2 1/2SM BR FEW120 20/20 A3014 RMK AO2		
08/12/97 06:39:27 SPECI KXXX 121134Z AUTO 00000KT 3SM BR FEW120 22/21 A3015 RMK AO2		
08/12/97 07:02:18 METAR KXXX 121156Z AUTO 36003KT 4SM BR CLR 23/22 A3015 RMK AO2 SLP206 70005 T02280217 10228 20183 51015		
08/12/97 07:57:23 METAR KXXX 121256Z AUTO VRB05KT 5SM HZ CLR 24/22 A3015 RMK AO2 SLP207 T02440217		
REVIEW OBSERVATION		
	PRINT	DATE
		PREV
	EXIT	BACK
		NEXT

EXAMPLE OF THE OID EDIT SCREEN

08:47:19 08/12/97 1347Z

HOME TOWN AIRPORT

SKY = CLR			
VISIBILITY = 5SM	TEMP/DEWPT = 26.1 /21.7 C 79 /71 F		
	WIND DIR/SPD = VRB/05		
PRESENT WX = HZ	ALTIMETER = 30.16		
REMARKS = RMK AO2			
METAR KXXX 121256Z AUTO VRB05KT 5SM HZ CLR 24/22 A3015 RMK AO2 SLP207 T02440217			
MAG WIND DIR/SPD: VRB/05			
RELATIVE HUMIDITY: 76	STATION PRESSURE: 29.85	PRINT	
	PRESSURE ALTITUDE: 60	REVUE	
SEA LVL PRESSURE: 1020.9	DENSITY ALTITUDE: 1400	SIGN	AUX

EXAMPLE OF THE OID 5-MINUTE SCREEN

08:47:19 08/12/97 1347Z

HOME TOWN AIRPORT

08/12/97 08:15:31 5-MIN KXXX 121315Z AUTO 02006KT 5SM HZ CLR 25/22 A3016 60 81 1300 030/06 RMK AO2		
08/12/97 08:20:31 5-MIN KXXX 121320Z AUTO 02006KT 5SM HZ CLR 25/22 A3016 60 81 1300 030/06 RMK AO2		
08/12/97 08:25:31 5-MIN KXXX 121325Z AUTO VRB05KT 5SM HZ CLR 25/22 A3016 60 81 1300 VRB/05 RMK AO2		
08/12/97 08:30:31 5-MIN KXXX 121330Z AUTO 03006KT 5SM HZ CLR 26/22 A3016 60 79 1300 040/06 RMK AO2		
08/12/97 08:35:31 5-MIN KXXX 121335Z AUTO VRB04KT 5SM HZ CLR 26/22 A3016 60 79 1300 VRB/04 RMK AO2		
08/12/97 08:40:31 5-MIN KXXX 121340Z AUTO 03005KT 5SM HZ CLR 26/22 A3016 60 76 1400 040/05 RMK AO2		
08/12/97 08:45:31 5-MIN KXXX 121345Z AUTO VRB05KT 5SM HZ CLR 26/22 A3016 60 76 1400 VRB/05 RMK AO2		
REVIEW 5 MINUTE		
PRINT		PREV
ARC2H	TIME	REV2H
EXIT	BACK	NEXT

EXAMPLE OF THE OID REVIEW SHEF SCREEN

08:47:19 08/12/97 1347Z

HOME TOWN AIRPORT

08/11/97 19:24:30 .A XXX 0812 DH0022/PPH 0.00
 08/11/97 20:24:28 .A XXX 0812 DH0122/PPH 0.03
 08/11/97 21:26:04 .A XXX 0812 DH0222/PPH 0.01
 08/11/97 22:26:04 .A XXX 0812 DH0322/PPH 0.00
 08/11/97 23:26:03 .A XXX 0812 DH0422/PPH 0.00
 08/12/97 00:26:57 .A XXX 0812 DH0522/PPH 0.00
 08/12/97 01:26:02 .A XXX 0812 DH0622/PPH 0.01
 08/12/97 02:39:05 .A XXX 0812 DH0722/PPH 0.00
 08/12/97 03:28:22 .A XXX 0812 DH0822/PPH 0.00
 08/12/97 04:28:19 .A XXX 0812 DH0922/PPH 0.00
 08/12/97 05:27:14 .A XXX 0812 DH1022/PPH 0.00
 08/12/97 06:28:23 .A XXX 0812 DH1122/PPH 0.00
 08/12/97 07:27:22 .A XXX 0812 DH1222/PPH 0.00
 08/12/97 08:24:29 .A XXX 0812 DH1322/PPH 0.00

REVIEW SHEF

PRINT	DATA	PREV
EXIT	BACK	NEXT

EXAMPLE OF THE OID MAINTENANCE SYSTEM-LOG (SYSLOG) SCREEN

08:47:19 08/12/97 1347Z

HOME TOWN AIRPORT

08/10/97 23:59 *SY 9999 AOMC CALLS TODAY: 0, AOMC SUCCESSFUL CALLS TODAY:
 0
 08/11/97 23:04 *ST 1958 ALL AFOS COMMUNICATION ATTEMPTS FAILED
 08/11/97 23:59 *SY 9999 CALLS ON PHONE LINES: LINE #1 0 CALLS LINE
 #2 0 CALLS LINE #3 0 CALLS LINE #4 0 CALLS LINE #5 0 CALLS LINE
 #6 0 CALLS LINE #7 0 CALLS LINE #8 0 CALLS
 08/11/97 23:59 *SY 9999 AOMC CALLS TODAY: 0, AOMC SUCCESSFUL CALLS TODAY:
 0

MAINTENANCE LOG

PRINT	DATA	PREV
	FILTR	
EXIT	BACK	NEXT

EXAMPLE OF THE OID 5-SECOND AVERAGE WIND SCREEN

08:47:19 08/12/97 1347Z

HOME TOWN AIRPORT

5-SECOND AVERAGE WIND					
READINGS	WIND DIR	WIND SPD	READINGS	WIND DIR	WIND SPD
OLDEST	359	5	12	356	6
23	354	5	11	340	6
22	350	6	10	354	5
21	351	6	9	352	5
20	356	6	8	360	5
19	16	6	7	1	6
18	19	7	6	356	7
17	19	7	5	355	6
16	6	7	4	357	6
15	358	6	3	6	6
14	356	6	2	3	6
13	356	5	NEWEST	18	5

CURRENT		
PRINT	PAGE	
		UPDATE
EXIT	BACK	

EXAMPLE OF THE OID 10-SECOND PRESSURE SCREEN

08:47:19 08/12/97 1347Z

HOME TOWN AIRPORT

10-SECOND PRESSURE			
READINGS	PRESSURE 1	PRESSURE 2	PRESSURE 3
OLDEST	29.854	29.863	
5	29.854	29.863	
4	29.853	29.863	
3	29.854	29.863	
2	29.853	29.863	
NEWEST	29.853	29.863	

CURRENT		
PRINT	PAGE	
		UPDATE
EXIT	BACK	

EXAMPLE OF THE OID 1-MINUTE CURRENT SENSOR DATA SCREEN

08:47:19 08/12/97 1347Z

HOME TOWN AIRPORT

1-MINUTE CURRENT SENSOR DATA										
UTC	VIS1	D/N1	VIS2	D/N2	VIS3	D/N3	TEMP	DEWPT	5SEC WIND	RVR
1342	5.19	D					79	71	24	8
1343	5.30	D					79	71	21	8
1344	5.34	D					79	71	33	6
1345	5.34	D					79	71	11	7
1346	5.37	D					79	71	16	7
1347	5.39	D					79	71	34	7
1348	5.36	D					79	71	353	6
1349	5.40	D					79	71	6	7
1350	5.45	D					79	71	356	7
1351										

PRECIPITATION AMOUNT (HOUR):	0.00	IN	
WATER EQUIVALENT (HOUR):	M	IN	
CURRENT SNOW DEPTH:	M	IN	

CURRENT		
PRINT	PAGE	
		UPDATE
EXIT	BACK	

EXAMPLE OF THE OID 1-MINUTE CURRENT SENSOR DATA SCREEN

08:47:19 08/12/97 1347Z

HOME TOWN AIRPORT

1-MINUTE CURRENT SENSOR DATA			
UTC	WX	ZR	TS
1337	NP	--	-
1338	NP	--	-
1339	NP	--	-
1340	NP	--	-
1341	NP	--	-
1342	NP	--	-
1343	NP	--	-
1344	NP	--	-
1345	NP	--	-
1346	NP	--	-
1347	NP	--	-
1348	NP	--	-
1349	NP	--	-
1350	NP	--	-
1351	NP	--	-

CURRENT		
PRINT	PAGE	
		UPDATE
EXIT	BACK	

EXAMPLE OF THE OID DAILY SUMMARY DATA SCREEN

08:47:19 08/12/97 1347Z

HOME TOWN AIRPORT

DAILY SUMMARY FOR 08/11/97			
24 HR MAX TEMP (F):	90	LATEST DAY MAX TEMP (0700-1900 LST):	90
24 HR MAX TEMP TIME (LST):	1614	LATEST NIGHT MIN TEMP(1900-0800 LST):	58
24 HR MIN TEMP (F):	58		
24 HR MIN TEMP TIME (LST):	0535	SKY COVER MID-MID (TENTHS):	
24 HR AVG TEMP (F):	74	SKY COVER SR-SS (TENTHS):	
DEPART FROM NORMAL:	0		
		TOTAL SUNSHINE (MINUTES):	M
HEATING DEGREE DAYS:	0	TOTAL SUNSHINE (HOURS):	M
COOLING DEGREE DAYS:	9	PERCENT POSSIBLE SUNSHINE:	M
		CHARACTER OF SUNRISE:	
PEAK WIND SPEED (MPH):	15	CHARACTER OF SUNSET:	
PEAK WIND DIR (DEG):	210	WEATHER (CODE):	1,2,8
PEAK WIND TIME (LST):	1558		
		DAILY DATA	
FASTEST 2MIN SPEED (MPH):	13	PRINT	PAGE
FASTEST 2MIN DIR (DEG):	170		PREV
FASTEST 2MIN TIME (LST):	1643		DATE
AVERAGE WIND SPEED (MPH):	2.7	EXIT	BACK
			NEXT

EXAMPLE OF THE OID DAILY SUMMARY DATA SCREEN

08:47:19 08/12/97 1347Z

HOME TOWN AIRPORT

DAILY PRECIPITATION SUMMARY FOR 08/11/97			
24 HR PRECIPITATION (IN):	0.04		
24 HR SNOWFALL (IN):			
SNOW DEPTH (IN):	M		
HOURLY INCREMENTAL PRECIPITATION VALUES (IN):			
0059	0.00	1259	0.00
0159	0.00	1359	0.00
0259	0.00	1459	0.00
0359	0.00	1559	0.00
0459	0.00	1659	0.00
0559	0.00	1759	0.00
0659	0.00	1859	0.00
0759	0.00	1959	0.00
0859	0.00	2059	0.04
0959	0.00	2159	0.00
1059	0.00	2259	0.00
1159	0.00	2359	0.00
		DAILY DATA	
		PRINT	PAGE
			PREV
			DATE
		EXIT	BACK
			NEXT

EXAMPLE OF THE OID DAILY SUMMARY DATA SCREEN

08:47:19 08/12/97 1347Z

HOME TOWN AIRPORT

DAILY PRESSURE SUMMARY FOR 08/11/97		
HOURLY STATION PRESSURE VALUES:		
0556	29.850	
1156	29.865	
1756	29.815	
2356	29.775	
AVERAGE STATION PRESSURE: 29.830		
MINIMUM SEA LEVEL PRESSURE: 30.06		
TIME OF OCCURRENCE: 1839		
DAILY DATA		
PRINT	PAGE	PREV
		DATE
EXIT	BACK	NEXT

EXAMPLE OF THE OID MONTHLY TEMPERATURE SUMMARY SCREEN

08:47:19 08/12/97 1347Z

HOME TOWN AIRPORT

MONTHLY TEMPERATURE SUMMARY - AUG97 SO FAR THIS MONTH		
AVG DAILY MAXIMUM: 86.7	MAXIMUM TEMPERATURE: 93	
AVG DAILY MINIMUM: 55.5	DATE(S) OF MAXIMUM: 3	
AVG MONTHLY TEMP: 71.1	MINIMUM TEMPERATURE: 47	
DEPART FROM NORMAL:	DATE(S) OF MINIMUM: 8	
NUM DAYS MAX 32 AND BELOW: 0	NUM DAYS MIN 32 AND BELOW: 0	
NUM DAYS MAX 90 AND ABOVE: 3	NUM DAYS MIN 0 AND BELOW: 0	
HEATING DEGREE DAYS	COOLING DEGREE DAYS	
MONTHLY TOTAL: 0	MONTHLY TOTAL: 71	
DEPART FROM NORMAL:	DEPART FROM NORMAL:	
SEASON (JUL 1 - JUN 30): 0(E)	SEASON (JAN 1 - DEC 31): 215(E)	
DEPART FROM NORMAL: 0(E)	DEPART FROM NORMAL: -255(E)	
MONTHLY DATA		
PRINT	PAGE	JULY
EXIT	BACK	

EXAMPLE OF THE OID MONTHLY PRECIPITATION SUMMARY SCREEN

08:47:19 08/12/97 1347Z

HOME TOWN AIRPORT

MONTHLY PRECIPITATION SUMMARY - AUG97 SO FAR THIS			
MONTH	PRECIPITATION	SNOW	
MONTHLY TOTAL:	0.42	M	
DEPARTURE FROM NORMAL:			
GREATEST IN 24 HOURS:	0.30		
DATE(S) OF OCCURRENCE:	4		
GREATEST DEPTH ON GROUND:		M	
DATE(S) OF OCCURRENCE:			
NUMBER OF DAYS WITH PRECIPITATION .01 INCH OR MORE: 4			
NUMBER OF DAYS WITH PRECIPITATION .10 INCH OR MORE: 1			
NUMBER OF DAYS WITH PRECIPITATION .50 INCH OR MORE: 0			
NUMBER OF DAYS WITH PRECIPITATION 1.00 INCH OR MORE: 0			
SHORT DURATION PRECIPITATION AMOUNTS WITH DATE/TIME TAGS:			MONTHLY DATA
5 0.04	051345 30 0.13	041200 100 0.20	041320
10 0.06	051350 45 0.15	041200 120 0.18	041200
15 0.07	041200 60 0.17	041200 150 0.28	041230
20 0.09	041200 80 0.18	041200 180 0.18	041200
		PRINT	PAGE JULY
		EXIT	BACK

EXAMPLE OF THE OID MONTHLY SUMMARY DATA SCREEN

08:47:19 08/12/97 1347Z

HOME TOWN AIRPORT

MONTHLY SUMMARY - AUG97 SO FAR THIS MONTH			
NUMBER OF CLEAR DAYS:			
NUMBER OF PARTLY CLOUDY DAYS:			
NUMBER OF CLOUDY DAYS:			
TOTAL SUNSHINE (HOURS):	M		
PERCENT POSSIBLE SUNSHINE:	M		
AVERAGE STATION PRESSURE:	29.785		
HIGHEST SEA LEVEL PRESSURE:	30.25 +		
DATE OF OCCURRENCE:	08		
TIME OF OCCURRENCE:	1048		
			MONTHLY DATA
LOWEST SEA LEVEL PRESSURE:	29.80 +		
DATE OF OCCURRENCE:	04		
TIME OF OCCURRENCE:	1847		
AVERAGE SEA LEVEL PRESSURE:	30.08		
		PRINT	PAGE JULY
		EXIT	BACK

EXAMPLE OF THE OID MONTHLY NORMALS SCREEN

08:47:19 08/12/97 1347Z

HOME TOWN AIRPORT

NORMALS FOR AUGUST														
DAY	TMIN	TMAX	TAVG	SUN	DAY	TMIN	TMAX	TAVG	SUN	DAY	TMIN	TMAX	TAVG	SUN
1	65	85	75	850	11	65	84	74	830	21	63	83	73	807
2	65	85	75	848	12	64	84	74	828	22	63	83	73	805
3	65	85	75	846	13	64	84	74	825	23	62	82	72	803
4	65	85	75	844	14	64	84	74	823	24	62	82	72	800
5	65	85	75	842	15	64	84	74	821	25	62	82	72	798
6	65	85	75	840	16	64	84	74	819	26	62	82	72	796
7	65	84	75	838	17	64	83	73	817	27	62	82	72	793
8	65	84	75	836	18	63	83	73	814	28	61	81	71	791
9	65	84	75	834	19	63	83	73	812	29	61	81	71	788
10	65	84	74	832	20	63	83	73	810	30	61	81	71	786
										31	61	81	71	784
										AVG/SUM: 63.5 83.3 73.4 25360				
MONTHLY NORMAL HEATING DEG DAYS: 0														
MONTHLY NORMAL COOLING DEG DAYS: 260														
MONTHLY NORMAL PRECIP: 4.14														
SEASON HEATING DEGREE DAYS: 0														
SEASON COOLING DEGREE DAYS: 730														
NORMALS														
			PRINT						PREV					
			EXIT			BACK			NEXT					

EXAMPLE OF THE OID SPECIAL ALERT (SPECI) CRITERIA SCREEN

08:47:19 08/12/97 1347Z

HOME TOWN AIRPORT

CRITERIA FOR SPECIAL ALERTS											
SKY CONDITION:											
CEILING AT OR BELOW		3000	1500	1000	500	FEET					
USER'S CEILING AT OR BELOW		0	0	0	0	0	0				
LAYERS BELOW		1000 FEET									
USER'S LAYERS BELOW		0	0	0	0						
VISIBILITY:		3	2	1	MILES						
USER'S VISIBILITY		1/2									
CRITERIA											
RVR:		2400 FEET									
			PRINT			PAGE					
			EXIT			BACK					

EXAMPLE OF THE OID LOCAL ALERT CRITERIA SCREEN

08:47:19 08/12/97 1347Z

HOME TOWN AIRPORT

CRITERIA FOR LOCAL ALERTS

SKY CONDITION:

CEILING AT OR BELOW 0 0 0 0 0 0 FEET

VISIBILITY: 5 MILES

CRITERIA

PRINT	PAGE	
EXIT	BACK	

EXAMPLE OF THE OID SHEF ALERT CRITERIA SCREEN

08:47:19 08/12/97 1347Z

HOME TOWN AIRPORT

CRITERIA FOR SHEF ALERTS

15-MINUTE ONSET THRESHOLD: 0.40 INCHES

15-MINUTE TERMINATION THRESHOLD: 0.02 INCHES

CRITERIA

PRINT	PAGE	
EXIT	BACK	

EXAMPLE OF THE OID SITE PHYSICAL CHARACTERISTICS SCREEN

08:47:19 08/12/97 1347Z

HOME TOWN AIRPORT

STATION		HOME TOWN AIRPORT	
NAME:	XXX	DATE:	08/12/97
IDENTIFIER:	COMM	TIME:	13:55:57 UTC
COMMISSIONED:	YES	UTC TO LST OFFSET:	-5
ATTENDED:	YES	METAR SWITCH DATE:	05/01/96 UTC
OPEN 24 HOURS:	YES	METAR SWITCH TIME:	07:45:00 UTC
OPENING TIME:		DSM GENERATED:	YES
CLOSING TIME:		PRIMARY DSM XMIT TIME:	UTC
ELEVATION:	281 FEET	INTERMED DSM XMIT TIMES:	19:01:00 UTC
FIELD ELEVATION:	277 FEET		UTC
PRESSURE SENSOR ELEVATION:	283 FEET		UTC
		MSM GENERATED:	YES
OBS HOURLY REPORT TIME:	50	MSM XMIT TIME:	UTC
OBS EDIT TIME:	5:00		PHYSICAL
OBS HOURLY TRANSMIT TIME:	55:00		
SHEF HOURLY TRANSMIT TIME:	22		
LATITUDE:	38.57N		
LONGITUDE:	77.27W		
MAG DECLINATION:	9W		

PRINT		
EXIT	BACK	

EXAMPLE OF THE OID SOFTWARE VERSION SCREEN

08:47:19 08/12/97 1347Z

HOME TOWN AIRPORT

UNIT	BOARD	NAME	DEVICE	VERSION	DATE
ACU	CPU A	PSOS OS	EPROM	1.81	03/07/95
	CPU B	PSOS OS	EPROM	1.81	03/07/95
	MEMORY	ACU APPLICATION	EPROM	2.60	06/26/97
	MEMORY	DCP APPLICATION	EPROM	2.60	06/26/97
DCP-1	CPU A	BOOT	EPROM	1.80	11/22/96
	MEMORY	DCP APPLICATION	RAM	2.60	06/26/97

SOFTWARE VERSIONS

PRINT		
EXIT	BACK	

APPENDIX B

ASOS Initial Operating Capabilities

ASOS SENSOR SPECIFICATIONS

PARAMETER	SENSOR	RANGE	ACCURACY
Cloud Height	Laser Ceilometer	100-12,000 Feet	± 100 Feet Or 5% Whichever Is Greater
Visibility	Forward Scatter Meter	< ¼ To 10+ Miles	± ¼ Mile To 1¼ Miles; Up To ± 2 reportable Increments Between 4 and 10 Miles
Present Weather Precipitation Identification	Precipitation Identifier (PI)	Detect Light, Moderate, And Heavy Rain Or Snow; Or Mixed Precipitation	Solid ¹ : 99 / 97 Liquid ¹ : 99 / 90
Freezing Rain Occurrence	Vibrating Element	Accumulation Over .01"/Hr	99% In Precipitation Rates As Low As 0.05"/Hr.
Obstructions To Vision	Derived From Other Sensors: (Temperature; Dew Point, Visibility)	Fog, Haze Reports	When Visibility Is < 7 Miles
Ambient Temperature	Resistive Temperature Device (RTD)	-80°F To +130°F	RMSE: 0.9°F To 1.8°F ²
Dew Point Temperature	Chilled Mirror	-30°F To +86°F ³	RMSE: 1.1°F To 7.9°F ²
Pressure	Redundant Pressure Cells	16.9"Hg - 31.5"Hg	± 0.02"Hg
Wind Direction	Vane	0 - 359°	± 5° (When Speed ≥ 5 Knots)
Wind Speed	Cup Anemometer	0 - 125 KTS	± 2 Knots Or 5% Whichever is Greater
Liquid Precipitation	Heated Tipping Bucket	0 - 10"/Hr	± 0.02" Or 4% Of Hourly Total Whichever is Greater
Thunderstorm	Wideband Electric Field	30 miles	Thunderstorms: 100 % within 10 miles; Cloud-to-ground lightning : 90% within 10 miles

¹% of occurrences detected / % correctly identified

²Dependent on operating range

³ASOS Program Office is working to increase the reportable range to: -80°F to +86°F

ASOS DATA CHARACTERISTICS

PARAMETER	SENSOR		ALGORITHM		
	Data Collection Frequency	Data Sampling Interval	Data Processing Frequency	Data Accumulation Period	Data Reporting Frequency
Cloud Height & Amount	~1/770 sec	12-sec	30-sec	30-min	1-min
Visibility	30-sec	1-min	1-min	10-min	1-min
Present Weather	1-sec	1-min	1-min	10-min	1-min
Freezing Rain	1-sec	1-min	1-min	15-min	1-min
Temp/Dew Point	10-sec	1-min	1-min	5-min	1-min
Wind	1-sec	5-sec	5-sec	2-min	5-sec; 1-min
Pressure	10-sec	1-min	1-min	1-min	1-min
Precipitation Accumulation	1-sec	1-min	1-min	1-min	15-min; 1-hour
Thunderstorm	1-sec	1-min	1-min	1-min	1-min

APPENDIX C

**Content of
ASOS-Generated
METAR**

**A Quick
Reference Guide**

KEY TO DECODE AN ASOS (METAR) OBSERVATION

METAR KABC 121755Z AUTO 21016G24KT 180V240 1SM R11/P6000FT -RA BR BKN015 OVC025 06/04 A2990
 RMK AO2 PK WND 20032/25 WSHFT 1715 VIS 3/4V1 1/2 VIS 3/4 RWY11 RAB07 CIG 013V017 CIG 017 RWY11
 PRESFR SLP125 P0003 60009 T00640036 10066 21012 58033 TSNO \$

TYPE OF REPORT	METAR: hourly (scheduled) report; SPECI: special (unscheduled) report.	METAR
STATION IDENTIFIER	Four alphabetic characters; ICAO location identifier.	KABC
DATE/TIME	All dates and times in UTC using a 24-hour clock; two-digit date and four-digit time; always appended with <u>Z</u> to indicate UTC.	121755Z
REPORT MODIFIER	Fully automated report, no human intervention; removed when observer signed-on.	AUTO
WIND DIRECTION AND SPEED	Direction to nearest ten degrees from true north (first three digits); next two digits: speed in whole knots; as needed Gusts (character) followed by maximum observed speed; always appended with <u>KT</u> to indicate knots; 00000KT for calm; if direction varies by 60° or more a Variable wind direction group is reported.	21016G24KT 180V240
VISIBILITY	Prevailing visibility in statute miles and fractions (space between whole miles and fractions); always appended with <u>SM</u> to indicate statute miles; values <1/4 reported as M1/4.	1SM
RUNWAY VISUAL RANGE	10-minute RVR value in hundreds of feet; reported if prevailing visibility is ≤ one mile or RVR ≤ 6000 feet; always appended with <u>FT</u> to indicate feet; value prefixed with <u>M</u> or <u>P</u> to indicate value is lower or higher than the reportable RVR value.	R11/P6000FT
WEATHER PHENOMENA	RA: liquid precipitation that does not freeze; SN: frozen precipitation other than hail; UP: precipitation of unknown type; intensity prefixed to precipitation: light (-), moderate (no sign), heavy (+); FG: fog; FZFG: freezing fog (temperature below 0°C); BR: mist; HZ: haze; SQ: squall; maximum of three groups reported; augmented by observer: FC (funnel cloud/tornado/waterspout); TS (thunderstorm); GR (hail); GS (small hail; <1/4 inch); FZRA (intensity; freezing rain); VA (volcanic ash).	-RA BR
SKY CONDITION	Cloud amount and height: CLR (no clouds detected below 12000 feet); FEW (few); SCT (scattered); BKN (broken); OVC (overcast); followed by 3-digit height in hundreds of feet; or vertical visibility (<u>VV</u>) followed by height for indefinite ceiling.	BKN015 OVC025
TEMPERATURE/DEW POINT	Each is reported in whole degrees Celsius using two digits; values are separated by a solidus; sub-zero values are prefixed with an <u>M</u> (minus).	06/04
ALTIMETER	Altimeter always prefixed with an <u>A</u> indicating inches of mercury; reported using four digits: tens, units, tenths, and hundredths.	A2990

REMARKS ON REVERSE SIDE

APPENDIX D

ASOS Voice

Vocabulary

ASOS VOICE VOCABULARY

(Revised 8/18/97)

a

airport
all quadrants
altimeter
and
at
automated weather
 observation
automated weather
 observing system

b

between
blowing snow
blowing snow in vicinity
blowing dust
blowing dust in vicinity
blowing sand
blowing sand in vicinity
broken

c

calm
ceiling
celsius
center
center field
clear

d

density altitude
dew point
distant
drizzle
dust storm
dust storm in vicinity

e

east
eight
estimated

f

feet
few
five
fog
fog in vicinity
four
freezing drizzle
freezing fog
freezing rain
funnel cloud

h

hail
haze
heavy drizzle
heavy dust storm
heavy freezing drizzle
heavy freezing rain
heavy ice pellets
heavy rain
heavy sand storm
heavy snow
hundred

i

ice pellets
information not available

j, k, l

left
less than
lightning
light drizzle
light freezing drizzle
light freezing rain
light ice pellets
light rain
light snow

m

minus

missing
mist

n

niner
north
northeast
northwest

o

one
one eighth
one half
one and one half
one and one quarter
one and three quarters
one quarter
one sixteenth
overcast

p

patches of fog
peak gusts
peak gusts in squalls
present weather

q, r

rain
remarks
right
runway

s

sand
sand storm
sand storm in vicinity
scattered
seven
shallow fog
six
sky condition

smoke
snow
south
southeast
southwest
special
squalls
surface visibility

t

temperature
temporarily inoperative
test
thousand
three
three and one half
three quarters
through
thunderstorm
tornado
tower visibility
two
two and one half

u, v

variable
vertical visibility
vicinity
visibility
volcanic ash

w

waterspout
west
wide spread dust
wind

x, y, z

zero
zulu

APPENDIX E

Acronyms

ACRONYMS

ACF	Area Control Facility	NLDN	National Lightning Detection Network
ACU	Acquisition Control Unit	NWS	National Weather Service
ADAS	AWOS Data Acquisition System	NWSTG	NWS Telecommunication Gateway
AGL	Above Ground Level	OFCM	Office of the Federal Coordinator for Meteorological Services and Supporting Research
ALS	ASOS Lightning Sensor		
ALDARS	Automated Lightning Detection and Reporting System	OID	Operator Interface Device
AMOS	Automated Meteorological Observing System	OMO	One-Minute Observation
AOMC	ASOS Operations and Monitoring Center	OTV	Obstruction to Vision
ARP	Airport Reference Point	OVC	Overcast
ARTCC	Air Route Traffic Control Center	PACE	PC-Based Asynchronous Communications Extension (for ASOS)
ASOS	Automated Surface Observing System	PI	Precipitation Identification
ATC	Air Traffic Controller	PLCD	Preliminary Local Climatic Data
ATCT	Air Traffic Control Tower	PV	Prevailing Visibility
AUTOB	Automated Observation	PWINO	Precipitation Identifier Information Not Available
AWIPS	Advanced Weather Interactive Processing System for the 1990s	RAMOS	Remote Automated Meteorological Observing System
AWOS	Automated Weather Observing System	RBC	Rotating Beam Ceilometer
AV-AWOS	Aviation Automated Weather Observing System	RMSE	Root Mean Square Error
BKN	Broken	RS	Record Special SAO
CF	Center Field	RTA	Remote Terminal to AFOS
CHI	Cloud Height Indicator	RTD	Resistive Temperature Device
CLR	Clear	RWP	Real-Time Weather Processor
CONUS	Continental United States	SA	Scheduled Record Hourly SAO
DCP	Data Collection Package	SAO	Surface Aviation Observation
DD	Dew Point Depression	SEV	Sensor Equivalent Visibility
DOD	Department of Defense	SCT	Scattered
FAA	Federal Aviation Administration	SHEF	Standard Hydrometeorological Exchange Format
FIBI	Filed But Impractical to Transmit	SID	Station Identifier
FMH-1	Federal Meteorological Handbook # 1 Surface Aviation Observations	SMCC	Systems Monitoring and Coordination Center
GAI	Global Atmospheric Inc.	SOC	Systems Operations Center
GFE	Government Furnished Equipment	SOD	Systems Operations Division
GOES	Geostationary Operational Environmental Satellite	SP	Special SAO
Hg	Mercury	SRRS	Service Records Retention System
hPc	Hectopascals	SUM	Software User's Manual
HTB	Heated Tipping Bucket (precipitation gauge)	TDZ	Touchdown Zone
Hz	Hertz	TNO	Thunderstorm Information Not Available
IOC	Initial Operating Capability	USP	Urgent Special SAO
IR	Infrared	UTC	Universal Coordinated Time
IREDD	InfraRed Emitting Diode	VDU	Video Display Unit
kHz	Kilohertz	WMSC	Weather Message Switching Center
LED	Light Emitting Diode	WMSCR	Weather Message Switching Center Replacement
LEDWI	Light Emitting Diode Weather Identifier	WSR-88D	Weather Surveillance Radar 1988, Doppler
LST	Local Standard Time	Z	Zulu Time
MWP	Meteorological Weather Processor	ZR	Freezing Rain
NADIN	National Airspace Data Interchange Network	ZRNO	Freezing Rain Information Not Available
NAS	National Airspace System		
NCDC	National Climatic Data Center		
NGRVR	New Generation Runway Visual Range	\$	Maintenance Check Indicator