

# Seismic Effects on the Design of Geosynthetic-Reinforced Earth Retaining Structures

by

JEFFREY J. CARTER

Bachelor of Civil Engineering, August, 1992,  
Auburn University, Auburn Alabama

Project report (CE 698) submitted in partial  
fulfillment of the requirements for the degree of

**MASTER OF ENGINEERING IN CIVIL ENGINEERING**

Department of Civil Engineering  
Old Dominion University  
Norfolk, Virginia  
July, 1998

Faculty Advisor  
Dr. Isao Ishibashi

Committee Members:  
Dr. A. Osman Akan  
Dr. Jaewan Yoon

19980813 055

DTIC QUALITY INSPECTED 1

# Table of Contents

<b>Chapter One:</b>	Introduction and Literature Studies	
	1.1 Introduction	3
	1.2 Previous Research	4
	1.3 Case Histories	8
<b>Chapter Two:</b>	Earth Pressure Theories and Design Methods	
	2.1 Static Earth Pressure	14
	2.2 Mononobe-Okabe Earth Pressure	19
	2.3 Koerner's Static Approach To GSRW Design	22
	2.4 Dynamic Earth Pressure Distribution	24
	2.5 Design methods	26
	Method A - Extended Koerner Method	27
	Method B - Modified Koerner Method	29
	Method C - Extended Rankine Method	31
	Method D - Modified Rankine Method	32
<b>Chapter Three:</b>	Sample Problem And Computational Results	
	3.1 GSRW Sample Problem	33
	3.2 CCRW Sample Problem	39
	3.3 Comparison Of Design Methods	43
<b>Chapter Four:</b>	Summary And Conclusions	51
<b>Bibliography</b>		52
<b>Appendix A</b>	Calculation Worksheets - Method A	
<b>Appendix B</b>	Calculation Worksheets - Method B	
<b>Appendix C</b>	Calculation Worksheets - Method C	
<b>Appendix D</b>	Calculation Worksheets - Method D	
<b>Appendix E</b>	Calculation Worksheets - CCRW	

# CHAPTER ONE

## Introduction and Literature Studies

### 1.1 Introduction

Since the early 1970's the use of geosynthetics to reinforce soil structures has increased to the point that it has now become a widely accepted industry standard. Use of geosynthetics in the reinforcement of soil retaining walls and slopes normally results in a cost efficient and safe alternative to more traditional soil stabilization means such as concrete or steel sheet pile retaining walls. More and more each day we see geosynthetics used to reinforce soil in support of bridge abutments, buildings of various shapes and sizes, railway systems, roads and parks and recreational areas. In addition, with such recent disasters as the earthquakes in Northridge, California (1994) and Kobe, Japan (1995), the study of the seismic effects on these new retaining structures has become even more important. If we want to expand the use of geosynthetics as a safe alternative to conventional soil support, we must ensure that engineers can design such structures with a high level of confidence to the resistance of seismic activity.

The use of geosynthetics has been established as a viable replacement for traditional methods of reinforcement in many geotechnical applications. They are used to line and cap landfills, drain pore water pressures from earth structures, separate soil types in road construction and provide added strength to earth structures.

At the same time, seismic events seem to be present in everyday life as we progress into the 21<sup>st</sup> century. We constantly turn on the television or scan a newspaper and hear or read about another earthquake disaster some place in the world. Therefore, for the purposes of this paper, the study will be limited to developing a design method for earth retaining structures that have been reinforced with geosynthetics and are subjected to cyclic motion such as that caused by earthquakes. It will examine some case studies of the performance of geosynthetic reinforced earth retaining structures (GSRW)<sup>1</sup> and review some time tested concepts dealing with both geosynthetics and seismic earth pressures. Finally, this paper will mesh the various concepts together to form a step-by-step procedure for designing one type of earth retaining structure and compare the results to an equivalent concrete cantilever retaining wall.

## **1.2 Previous Research**

The earliest practical research was conducted by Gregory N. Richardson and Kenneth L. Lee at UCLA in the middle 1970's. Through laboratory experiments they showed that steel tie reinforced earth walls responded to input vibrations like a nonlinear damped plastic system. From this they developed an empirical force envelope for designing earth walls subjected to the increased earth pressures caused by seismic activity (Richardson and Lee, 1975). For their tests, Richardson and Lee substituted aluminum strips for the steel tie reinforcement and assumed standard

---

<sup>1</sup> Throughout current technical papers the acronym GSRW is commonly used to refer to geosynthetic-reinforced earth retaining structures. It will be used within this paper in the same manner.

Rankine type earth pressure conditions governed the static loading. Their basic quest was to observe one of two failure modes, either pullout of the strips (ductile failure) or breakage of the strips (brittle failure). Pullout is what determines the overall length of the reinforcement strips which are comprised of both resisting and non-resisting segments. In regard to Rankine's failure plane, the non-resisting portion is that part of the strip which is located between the failure plane and the face of the wall. This area provides no resistance to pullout but is still critical for the second failure mode, strip breakage. In this mode, every inch of the strip is susceptible to breakage due to strength failure. One of the most important contributions Richardson and Lee made was that of the two failure modes, strip breakage seems to be more dangerous.

Mainly because breaking of enough strips at one time can, and most likely will, cause a complete brittle mode of failure of the entire wall system. Pullout failure causes a ductile failure and is generally less destructive. In addition, when the seismic vibrations cease, the ductile failure, if not already too far advanced, will most likely also cease. The soil and wall system will still have some of its soil retaining and bearing strengths<sup>2</sup>.

Another interesting point Richardson and Lee discovered is that since the seismic effect is more pronounced at the top of the wall than at the bottom, the reinforced wall system tends to fail from the top down. In other words, a vertical wall

---

<sup>2</sup> It is important to note that while failure due to cyclic loading may cease when the vibrations do, wall stability failure may continue due to other effects such as increased soil liquefaction or bearing capacity failure.

tends to fail in a rollover fashion. This is exactly the failure mode that is predicted and expected when the structure is designed properly under static conditions alone. When coupled with the cyclic loading during an earthquake, the danger of rollover failure is amplified.

Many other scientists and engineers have also studied geosynthetics and seismic activity. Some have created design techniques for a GSRW in the static case only while others have introduced bits and pieces into the various methods that take into account how the GSRW will react to cyclic input. Cascone et al. (1995) proposed a simple equation for determining the number of strips needed to maintain stability of a reinforced earth retaining structure. Using a limit equilibrium analysis and assuming the only failure mode was breakage of the strips, they assumed slippage could not occur. He also stated that failure in one strip alone would cause a domino effect on the other strips and failure of the entire wall would occur. While this approach may be simple and straight forward, the limiting factors are too constraining on the process. They do not account for ductile failure, which is the most common type of failure mode for these types of structures. In addition, their method is limited to structures with facing slopes ranging from  $40^{\circ}$  to  $70^{\circ}$  from the horizontal, seismic accelerations of 0 to 0.3g and backfill pore water pressure coefficients from 0 to 0.5. These limitations along with those previously pointed out make the Cascone et al. (1995) method impractical for current design use and overly conservative.

In 1992 Yogendrakumar et al. used two finite element computer programs, developed by Richardson (1976) and Finn et al. (1986), to compare theoretical data with actual field test data. The computer programs use an equivalent linear elastic model with the assumption that the dynamic response of a nonlinear material can be approximated by a damped elastic model with properties resembling the soil conditions. The solution is based on the simple spring dashpot-mass system with the following equation:

$$M\Delta\ddot{x} + C\Delta\dot{x} + K\Delta x = -mI\Delta a \quad (1.1)$$

where;

M = system mass matrix

$\Delta a$  = base acceleration

C = damping coefficient

$\Delta x$  = relative displacement vector

K = spring coefficient

$\Delta\dot{x}$  = relative velocity vector

I = unit vector

$\Delta\ddot{x}$  = relative acceleration vector

m = system mass

While both of these computer programs yielded results very close to actual field data, they are extremely cumbersome and complicated to use. Not all of the soil parameters are known at the start of the analysis; they must be estimated with some reliability on their accuracy. The user must estimate the initial values of both C and K and then adjust these estimates during subsequent program iterations. This is an almost impossible feat for most engineers to competently accomplish when in the

design stage. Unless they have extensive experience in the local area, the majority of engineers are not able to make a reasonable estimation of the values without first completing costly geotechnical testing of the soil. This adds both expense and delays to the overall design and is not normally feasible in today's competitive market.

Another limitation is the program's tendency to over-estimate the seismic response of the soil structure due to pseudo-resonance (Finn et al. 1986). It implies that, if the fundamental period of both the input motion and the soil structure are the same, the resulting impact will be calculated to a greater amount by the computer finite element program and the overall results will be very conservative. Again, these programs are complicated and the user must fully understand their limitations if they are to be employed in either design or research.

### **1.3 Case Histories**

While earthquake damage and destruction have been documented and studied for many years, the majority of the effort has been on the study of more classical structures. Structural engineers want to know how a particular design for a concrete or steel structure held up during heavy seismic activity. They want to catalogue certain aspects of the design which faired well for future use and redesign those systems that did not work. Until recently, little study of geosynthetically reinforced earth structures has been undertaken. Dr. F. Tatsouka, University of Tokyo, has published some extensive data on the performance of many GSRWs during the Great



Hanshin-Awaji Earthquake in Kobe, Japan in January, 1995. It was a 7.2 magnitude earthquake that did extensive damage to the Osaka area with a high concentration in the city of Kobe.

Of particular interest was the performance of brick and masonry retaining walls compared to retaining walls reinforced with geosynthetics. Tatsouka et al. (1995) showed that the geosynthetically reinforced retaining structures performed much better and were much more reliable than traditionally constructed earth retaining structures. Retaining walls constructed of unreinforced masonry units, leaning-type unreinforced concrete retaining walls and gravity-type unreinforced retaining walls were not designed for seismic performance and experienced severe damage as a result of the earthquake. These systems were all designed with gravity type resistance as the mainstay of the wall to resist the lateral pressures of the static backfill and the static loads placed on them. It seems that no consideration of the possible dynamic loads a wall may experience was used in the original design. Or maybe when these walls were designed and constructed, the up-to-date engineering theories and practices of the time had little understanding of how seismic forces would effect earth structures. All of the cases Tatsouka et al. reviewed prove that the free standing, gravity type earth retaining structures have little resistance to seismic induced forces. At the same time, the geosynthetically reinforced retaining structures can withstand much higher seismic forces and retain a greater portion of their structural stability. This was also true for a GSRW that was designed neglecting any

potential seismic effect. Even these walls provided better resistance to high cyclic forces from an earthquake, albeit, not to the same extent as a current dynamic design could be expected. It is also noted that while extensive soil liquefaction occurred to large areas of uncompacted land during the earthquake, it seemed to have no measurable effect on the supporting ground or backfill of geosynthetic reinforced retaining walls. The horizontal accelerations were the dominant forces that caused damage to all types of reinforced retaining structures (Tateyama et al. 1995). From this, one could conclude that the properly designed and installed geosynthetic layers of the retaining structure will provide additional resistance to soil liquefaction in sands. To what extent is unknown and no research dealing with this particular subject could be found.

From the Kobe earthquake, four concentrated locations were described where GSRWs were used for the support of road or railway embankments. The retaining walls ranged anywhere from 2m to 6m in height and 300m to 1km in length. Each wall was constructed in relatively the same manner and most of the subject walls were located in some of the most intense areas of seismic activity. While numerous structures around them were severely damaged, these retaining walls experienced only minimal damage or movement. Some of the geogrid supporting railway track had settled as much as 15cm, which at first may seem extensively large. However, when compared to the deformations and settlements of railway tracks located in unreinforced embankment zones, it is very small (Tatsouka et al. 1995). A 15cm

settlement constitutes a range of 2.5% to 7.5% settlement on these walls, very small considering the magnitude of the earthquake and the location of its epicenter. During an earthquake, this type of small settlement could become critical to saving numerous lives and vast amounts of infrastructure. If road and railway embankments and supports can be confidently designed and relied on to maintain the majority of their strength during the earthquake, they can also be relied upon to be in a generally serviceable condition. Hence, vital search and rescue and damage assessment teams along with emergency vehicles and personnel could get to the effected area at a much faster rate. When a reliable and simple method for designing earth retaining structures to resist seismic forces is developed, it will automatically become the method of choice among engineers be used on a wide spread basis in high probable earthquake zones.

Tatsouka et al. (1995) and Tateyama et al. (1995) also showed that geosynthetically reinforced retaining walls experiencing seismic deformations conclusively fail in a top down or rollover fashion. Again, this is an important fact when developing a design method and is in agreement with Richardson and Lee (1975). We need to know how the wall will fail before we can effectively design against it. Tatsouka et al. (1995) also stated that the most dangerous failure mode of a retaining wall is over-turning about its base because "... it is abrupt in a brittle and uncontrollable manner, which may result in very serious damage to structures and human beings located on the backfill and in front of the wall." Speculation could lead

to an interpretation of his meaning to be as a portion of the top of the wall fails, it relieves the normal stress on the layers below it. This in-turn reduces the holding power of the lower and normally shorter layers below which will then also fail. The author tends to disagree with this notion. If the top portions rollover and completely disengage themselves from the structure, the remaining layers below are subjected to less stress and therefore require less resistance. They also stated that a large number of gravity type retaining structures collapsed in the overturning failure mode. This is true, however, geosynthetic faced walls are not rigid like concrete or steel retaining structures. They tend to act in a more ductile manner because the geosynthetic layers will deform to new shapes when the soil they retain reshapes itself during cyclic motion. Even though the wall may deform into a new shape, the geosynthetic layers will continue to support the backfill soil, albeit, of a reduced magnitude. Tatsouka et al. stated that wall sliding, while not preferable, can be tolerated. The failure here is ductile failure and is more stable than overturning failure. The author agrees with this. However, it will be shown in Chapter Three that when designing against seismic forces, sliding tends to be the dominant factor.

In review of various other design methods for a GSRW with seismic effects, it has been common to design it by simply using the total static approach and changing some of the parameters. These changes occur in numerous fashions with the most common being an increase in the factor of safety or using very conservative soil parameters. Arbitrarily changing the factor of safety from 2 to 4 or decreasing soil

parameters such as the  $\phi$  angle in cohesionless soils or the cohesive strength in clays by a certain percentage is nothing more than a guess. No real value or estimation of the expected strength of an earthquake for the local area has been done, nor has any thought been given as to how the structure may fail and at what point it will fail. All of these factors are extremely important to the life expectancy of any structure. Any engineer would insist on knowing the critical factors when designing a steel or concrete structure and as such the geotechnical engineer should except no less. The most careful design and construction of a building or transportation system is useless if the foundation on which it sits is not as carefully designed.

## Chapter Two

# Earth Pressure Theories and Design Methods

### 2.1 Static Earth Pressure

The pressure exerted on an earth retaining structure can be conceptualized in many forms<sup>3</sup>. The simplest way to understand how lateral earth pressures are handled is to group them into three general states; Active, At-Rest and Passive. Visualize a simple retaining wall such as that shown in Figure (2-1). The wall can either move left, right or stay in its current position. The active state can be thought of as the backfill soil placing an increased burden of pressure onto the retaining wall. The wall is thought to be moving away from the soil structure and the soil tends to *stretch* in a horizontal manner. The passive state is the opposite of the active state. The wall is thought to move laterally into the backfill soil and horizontally *compresses* the soil structure. Finally, the at-rest state is when neither the wall nor the backfill soil structure moves in either direction. Both are considered to be at-rest and neither has been subjected to lateral yielding.

It is widely accepted that the yield required to develop the active state is far less than that developed in the passive state and therefore most of the attention is placed here. This is why the active state is thought to be the more critical. In other

---

<sup>3</sup> A detailed explanation of static earth pressures can be found in various text books devoted to soil engineering. The major source used in this paper is from the author's educational experiences and from Dunn et al. (1980).

words, the active state requires less stress for it to develop into a critical condition, thus, it will be the main case considered in this paper.

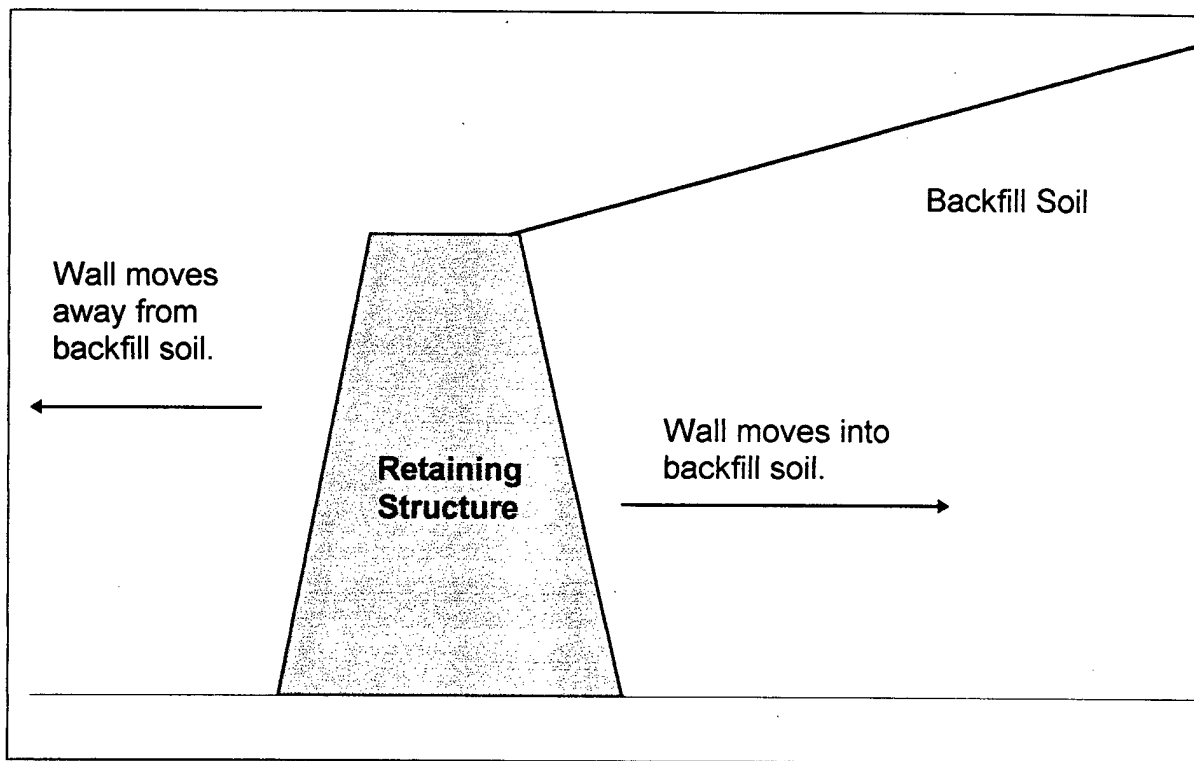
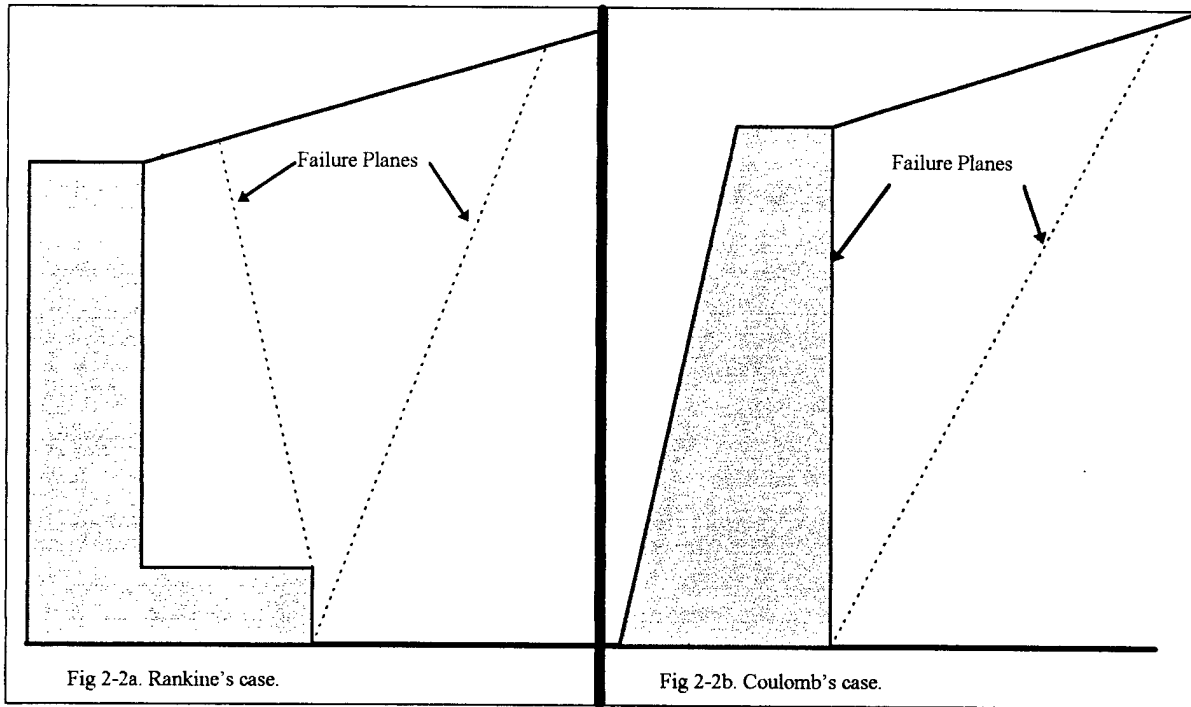

Figure 2-1: Illustration of active and passive state concepts.

In order to calculate the pressure developed on a retaining structure due to the active backfill behind it, one must also consider how the failure plane is developed.

In the Rankine case, the two failure planes extend from the bottom of the inner toe of a cantilever wall up through the backfill soil to the surface as shown in the Figure (2-2a).

The total static pressure exhibited on the wall due to the active case is found by calculating the pressure of the backfill behind it and multiplying it by coefficient of active earth pressure ( $K_A$ ). The backfill pressure is a simple triangular shaped



**Figure 2-2: Failure planes for two types of retaining walls.**

pressure distribution from the top of the wall down and is equal to the unit weight of the backfill soil ( $\gamma$ ) multiplied by the height of the retaining wall ( $H$ ) or:

$$\sigma_A = \gamma H K_A \quad (2.1)$$

and from Rankine:

$$K_A = \tan^2(45 - \phi/2) \quad (2.2)$$

where  $\phi$  is the backfill soil friction angle.

Coulomb derived this equation for active earth pressure in the late 1700's and engineers currently use it as the basis for the vast majority of their geotechnical



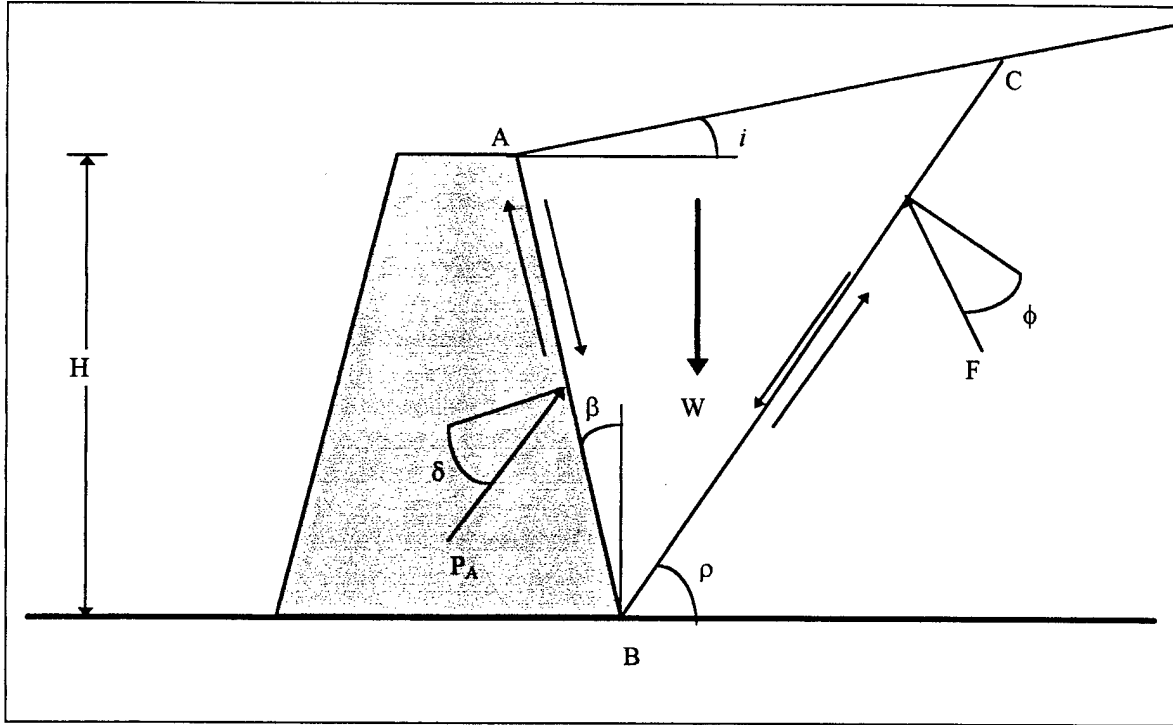

Figure 2-3: Coulomb's active earth pressure.

engineering decisions concerning lateral earth pressures. Figure (2-2b) is a typical application of Coulomb's earth pressure against a gravity retaining structure. In addition to a failure plane within the backfill, the back face of the wall is also a failure plane in this case, as shown in Figure (2-3). It has proven to be a reliable prediction of the total force caused by a dry cohesionless backfill placed against a retaining wall. A more useful form of the equation is when it is transformed into the following force equation:

$$P_A = \frac{1}{2} \gamma H^2 K_A \quad (2.3)$$

where:

$P_A$  = active force per unit length of the wall,

$\gamma$  = unit weight of the backfill soil,

$H$  = height of the retaining wall, and

$K_A$  = active earth pressure coefficient, which is given by:

$$K_A = \frac{\cos^2(\phi - \beta)}{\cos^2 \beta \cos(\delta + \beta) \left[ 1 + \left\{ \frac{\sin(\delta + \phi) \sin(\phi - i)}{\cos(\delta + \beta) \cos(\beta - i)} \right\}^{1/2} \right]^2} \quad (2.4)$$

$P_A$  is applied at a height of  $H/3$  from the base of the wall without a surcharge load.

Referring to Figure (2-3), the angles used in the Coulomb  $K_A$  equation are:

$\phi$  = soil friction angle.

$\beta$  = angle of the wall face to vertical.

$\delta$  = angle of friction between the backfill soil and the wall face.

$i$  = angle between the backfill soil surface and the horizontal.

BC = the failure plane.

Note that Equation (2.4) will reduce to Equation (2.2) when  $i$ ,  $\beta$  and  $\delta$  in Figure (2-3) are all equal to zero. Figure (2-4) shows the static lateral earth pressure distribution from backfill soil and for a surface load of magnitude ( $q$ ). The static pressure on the wall can be converted to a static force on the wall through geometry. If the pressure distribution for the surface load is a rectangle, then the total force exerted by the load is equal to the area of the rectangle and is applied at the mid-point on the wall. In the same sense, the force for the triangle is equal to the area of the

triangle and is applied one-third of the height up the wall. Again, these are static forces and while present during an earthquake in a similar form, should not be confused with the dynamic forces generated by the earthquake.

## 2.2 Mononobe-Okabe Earth Pressure

In the 1920's Mononobe and Okabe (separately) modified Coulomb's active earth pressure equation to account for vertical and horizontal coefficients of acceleration induced by an earthquake (Das, 1983). Two new coefficients are introduced here. The horizontal seismic coefficient ( $k_h$ ) and the vertical seismic coefficient ( $k_v$ ). The inertia forces in the horizontal and vertical directions respectively are  $k_h W$  and  $k_v W$ , where  $W$  is the weight of the soil between the wall and the failure plane and;

$$k_h = \frac{PGA_h}{g} \quad \& \quad k_v = \frac{PGA_v}{g} \quad (2.5)$$

with;

$PGA_h$  = Peak ground acceleration in the horizontal direction,

$PGA_v$  = Peak ground acceleration in the vertical direction, and

$g$  = acceleration due to gravity.

The following assumptions concerning the Mononobe-Okabe solution are essential to the application of the theory and are taken directly from Das (1983):

1. The failure planes are the same as that shown in Figure 2-3.
2. The movement of the wall is sufficient to produce minimum active pressure.
3. The shear strength of the dry cohesionless soil can be given by the equation  $s = \sigma' \tan \phi$ , where  $\sigma'$  is effective stress and  $s$  is shear strength.
4. At failure, full shear strength along the failure plane (plane BC in fig 2-3) is mobilized.
5. The soil behind the retaining wall behaves as a rigid body.

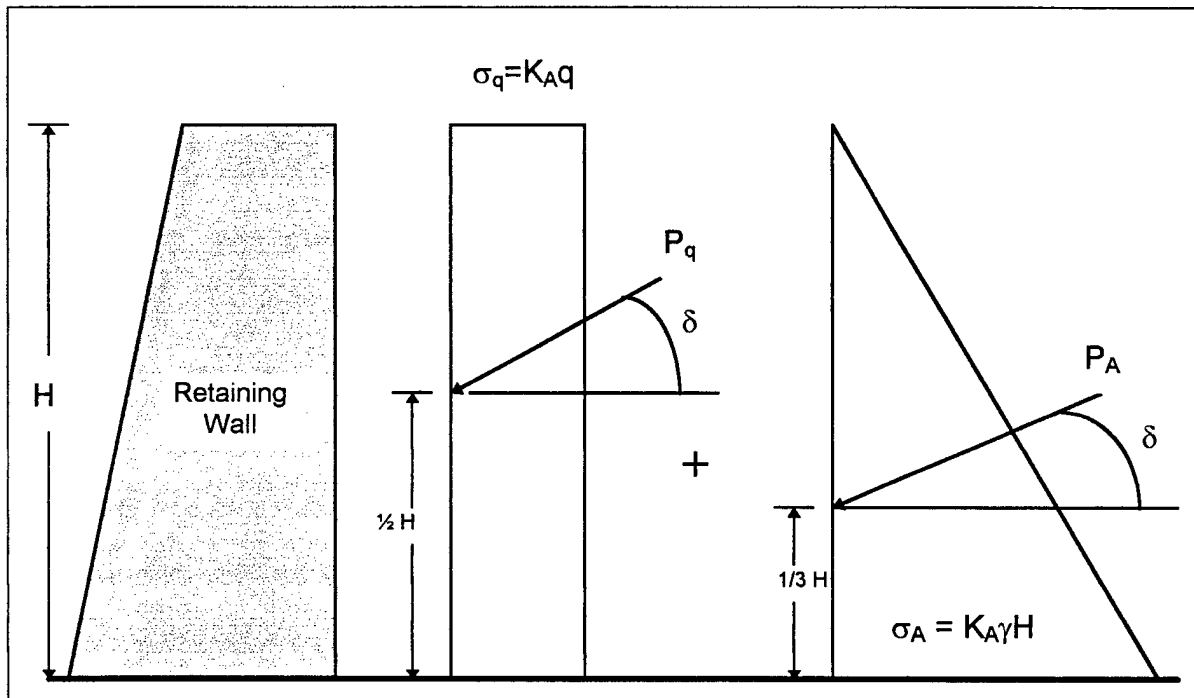

Figure 2-4: Static pressure distribution.

With the addition of the seismic coefficients, the force applied to the wall by the backfill soil under a seismic load now becomes the Mononobe-Okabe active earth pressure equation:

$$P_{AE} = \frac{1}{2} \gamma H^2 (1 - k_v) K_{AE} \quad (2.6)$$

where  $K_{AE}$  is the seismic active earth pressure coefficient:

$$K_{AE} = \frac{\cos^2(\phi - \theta - \beta)}{\cos \theta \cos^2 \beta \cos(\delta + \beta + \theta) \left[ 1 + \left\{ \frac{\sin(\delta + \phi) \sin(\phi - \theta - i)}{\cos(\delta + \beta + \theta) \cos(\beta - i)} \right\}^{1/2} \right]^2} \quad (2.7)$$

and 
$$\theta = \tan^{-1} \left( \frac{k_h}{1 - k_v} \right) \quad (2.8)$$

For this discussion and many cases in practice, it is assumed  $k_v = 0$ .

The Mononobe-Okabe dynamic earth pressure solution is in essence Coulomb's solution (Figure 2-5a) rotated counterclockwise by angle  $\theta$  (Equation 2.8) so that the resultant force (Figure 2-5b) is in the vertical direction (Ichihara 1969). Also, Table (2-1) from Ichihara (1969) is useful when transforming from Coulomb's equation to the Mononobe-Okabe method.

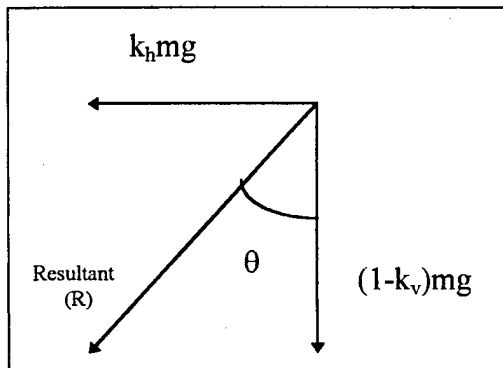

Fig 2-5a Coulomb

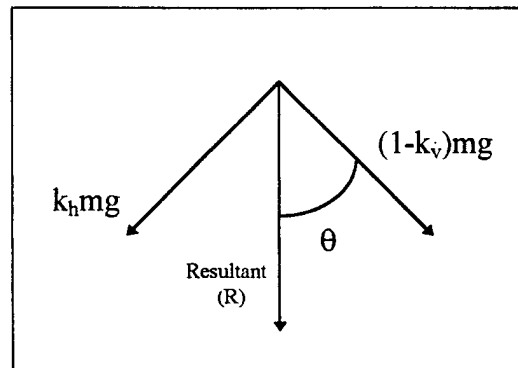

Fig 2-5b Mononobe-Okabe

Once the variable transformation utilizing Table (2-1) has been incorporated into Coulomb's equation, the Mononobe-Okabe method provides a useful pseudo-static approach to calculating the seismic effects an earthquake can have on a retaining wall.

**Table 2-1: Variable transformation for Coulomb to Mononobe-Okabe (Ichihara 1969).**

<b>Coulomb's Equation Variables</b>	<b>Dynamic Active case</b>	<b>Dynamic Passive Case</b>
H	$H \frac{\sin(\alpha - \theta)}{\sin \alpha}$	$H \frac{\sin(\alpha + \theta)}{\sin \alpha}$
$\gamma$	$\frac{1 - k_v}{\cos \theta} \gamma$	$\frac{1 - k_v}{\cos \theta} \gamma$
$\alpha$	$\alpha - \theta$	$\alpha + \theta$
$\beta$	$\beta + \theta$	$\beta - \theta$
q	$\frac{1 - k_v}{\cos \theta} q$	$\frac{1 - k_v}{\cos \theta} q$
$\delta$	$\delta$	$\delta$

### 2.3 Koerner's Static Approach to GSRW Design

Koerner (1994) provided the following step-by-step approach for the static design of a vertical wall reinforced with geosynthetics:

A) Design for internal stability.

1) Determine the lateral pressure applied. Consider surface loads as well as the backfill soil load. A general equation is:

$$\sigma_h = K_A q + K_A \gamma z \quad (2.9)^4$$

<sup>4</sup> In this paper, general equations have been used and are illustrative in nature only. They have been tailored to fit the example problems. Each actual situation will present a unique set of circumstances and must be dealt with independently.

where:

$K_A$  = active earth pressure coefficient,

$z$  = depth, and

$q$  = the surface load

2) Calculate the allowable stress in the reinforcement fabric.

$$T_{\text{allow}} = T_{\text{ult}} / (FS_{\text{ID}} \times FS_{\text{CR}} \times FS_{\text{CD}} \times FS_{\text{BD}}) \quad (2.10)$$

where,

$T_{\text{allow}}$ : the allowable tensile strength of the fabric,

$T_{\text{ult}}$ : the ultimate breaking strength of the fabric,

FS: the partial safety factor with<sup>5</sup>

$FS_{\text{ID}}$  - installation damage,

$FS_{\text{CR}}$  - creep,

$FS_{\text{CD}}$  - chemical degradation, and

$FS_{\text{BD}}$  - biological degradation.

3) Calculate the allowable layer spacing.

$$S_v = T_{\text{allow}} / (\sigma_h * FS) \quad (\text{here FS is global}) \quad (2.11)$$

4) Calculate the embedment and overlap lengths.

$$L_e = \frac{S_v \sigma_h (FS)}{2(c + \gamma z \tan \delta)} \quad (\text{embedment length}) \quad (2.12)$$

$$L_R = (H - z) \tan\left(45 - \frac{\phi}{2}\right) \quad (\text{nonresisting length}) \quad (2.13)$$

---

<sup>5</sup> See Koerner (1994) Table 2.12, p.159 for a complete explanation of partial safety factors.

$$L_o = \frac{S_v \sigma_h (FS)}{4(c + \gamma z \tan \delta)} \geq 3' \quad (\text{overlap length}) \quad (2.14)$$

B) Design for external stability.

1) Overturning:

$$FS_{OT} = \frac{\text{resisting moments}}{\text{driving moments}} \quad (2.15)$$

2) Sliding:

$$FS_{SL} = \frac{\text{resisting forces}}{\text{driving forces}} \quad (2.16)$$

3) Bearing capacity:

$$FS_{BC} = \frac{q_{ult}}{q_{act}} \quad (2.17)$$

These steps are only part of the entire design process and each step in the process will be explained in more detail in the next chapter. Additional design would be needed for miscellaneous details such as roll overlap and connection details. It is not addressed here mainly because there will be little difference in the design procedure. However, the static and dynamic stresses and forces used in the design will be the same as those developed in this paper.

## 2.4 Dynamic Earth Pressure Distribution

Thus far we have discussed the distribution of static earth pressure only. When subjected to cyclic motion, the pressure distribution behind a wall will change dramatically. In Section (2.1) we saw that the earth pressure distribution from the backfill was triangular in shape, and for the constant surface load it was a rectangle.



However, the dynamic distribution is somewhat different. Bathurst and Cai (1995) show that the total dynamic pressure distribution is made up of the static component (from Section 2.1) plus a dynamic increment. Figure (2-6) depicts the shape of the dynamic pressure distribution. The shape is now a polygon and thus the forces

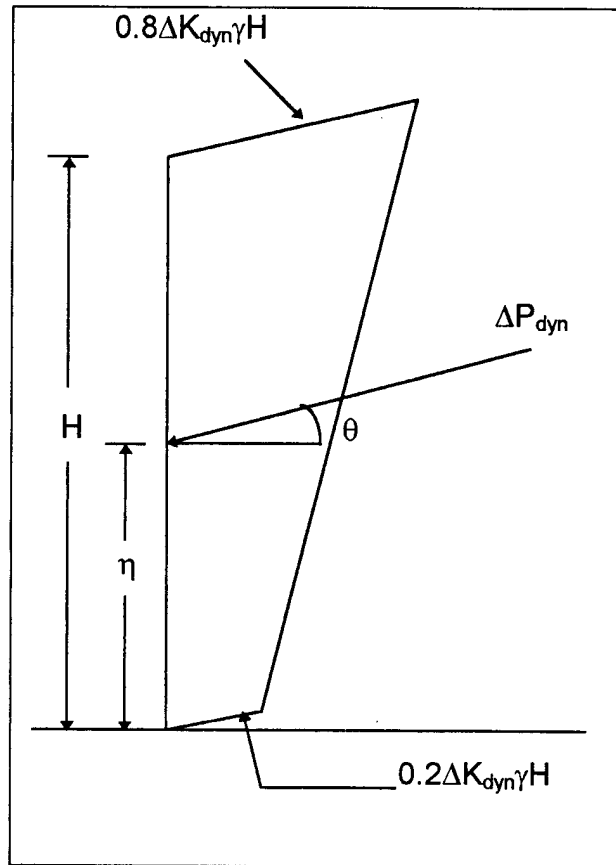

Figure 2-6: Dynamic earth pressure distribution.

derived from it are calculated slightly differently.

Breaking the above geometrical shape into an equivalent rectangle and triangle, the value of  $\eta$  can be derived as:

$$\eta = \frac{(0.2 * 1/2 H + 0.3 * 2/3 H)}{0.5} = \frac{3}{5} H \quad (2.18)$$

Bathurst and Cai (1995) report that  $\eta$  lies somewhere between 0.4H and 0.7H and shaking table tests by Ishibashi and Fang (1987) indicated that a value of 3/5H or 0.6H is not considered unreasonable.

$\Delta P_{\text{dyn}}$  is the incremental dynamic force addition to the total static force placed on the wall such that:

$$P_{\text{AE}} = P_q + P_A + \Delta P_{\text{dyn}} \quad (2.19)$$

$$= HqK_{\text{AE}} + 1/2\gamma H^2 K_A + 1/2\gamma H^2 \Delta K_{\text{dyn}} \quad (2.19a)$$

where;

$$\Delta K_{\text{dyn}} = K_{\text{AE}} - K_A \quad (2.20)$$

It should be noted that  $\Delta P_{\text{dyn}}$  is not distributed in a triangle form but, rather distributed in a polygon form as seen in Figure (2-6).

## 2.5 Design Methods

Sections 2.1 through 2.4 have explained concepts currently used in the design of earth retaining structures. What is attempted here is to derive a pseudo-static approach to designing geosynthetic reinforced retaining structures subjected to seismic loading utilizing portions of the mentioned concepts. Four slightly different

methods were employed during this research and will be explained in more detail in each section. Refer to Figure (2-7) for the geometry of the problem<sup>6</sup>.

### **Method (A) - Extended Koerner Method.**

This is the design method shown in Koerner (1994) using Coulomb's application of  $P_A$  with Rankine's  $K_A$  value extended to the dynamic case. It is probably not the best idea to mix the Coulomb and Rankine theory, however, Koerner did so in his explanation of the static design and the same will be done for this method. To "extend" Koerner's method to the dynamic case, Equation (2.9) becomes;

$$\sigma_{\text{dyn}} = K_{AE}q + K_A\gamma z + \Delta K_{\text{dyn}}\gamma(0.8H-0.6z) \quad (2.21)$$

This equation is substituted for  $\sigma_h$  in all of the internal stability equations in Section 2.3. The failure plane angle  $\rho$  in Figure (2-7) is assumed to be a constant value,  $45^\circ + \phi/2$ , for all static and dynamic cases. To calculate the various external stability components, it is easiest to break the pressure distributions into distinct rectangles and triangles (two each in this case) and then calculate the total force from these new shapes (see Figure 2-8). The calculated force  $P_{AE}$  will be the sum of the four forces in Figure (2-8) and will be located at height (h) from the base:

---

<sup>6</sup> Note that the geometry will be fixed here for simplicity. It can be changed and adapted to fit any situation.

$$h = \frac{\frac{1}{2} HP_q + \frac{1}{3} HP_A + \frac{2}{3} HP_{dyn1} + \frac{1}{2} HP_{dyn2}}{P_q + P_A + P_{dyn1} + P_{dyn2}} \quad (2.22)$$

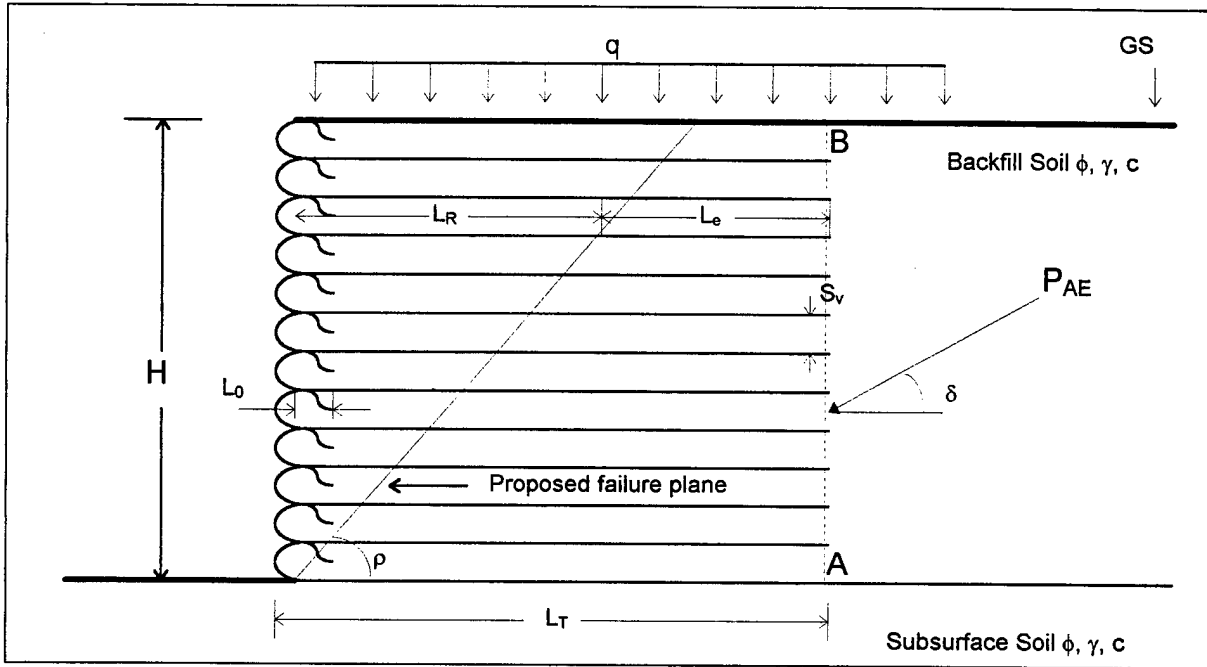

Figure 2-7: Typical geosynthetic reinforced retaining structure.

Koerner then calculates the vertical and horizontal components of  $P_{AE}$  as,

$$P_{AE,V} = P_{AE} \sin(\delta) \quad \text{and} \quad P_{AE,H} = P_{AE} \cos(\delta) \quad (2.23)$$

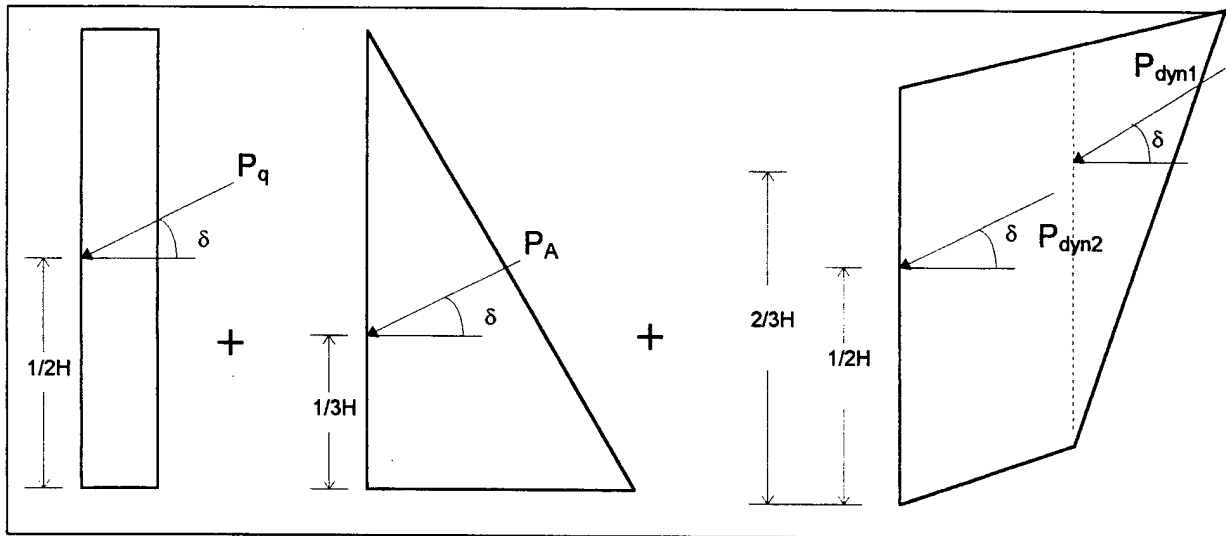

Figure 2-8: Static and dynamic pressure distribution.

respectively. Simplistic summing of the resisting moments (usually about the toe of the wall) and dividing them by the driving moments will produce a factor of safety for over turning (Equation 2.15). Summing of the sliding resisting forces and dividing them by the sliding driving forces will provide the factor of safety against sliding along the base (Equation 2.16). Bearing capacity is also of great importance in the dynamic case (Equation 2.17), however, it is too vast a topic to be included here. Nevertheless, there are numerous articles and publications dealing with dynamic bearing capacity for earth retaining structures. The geosynthetically reinforced retaining wall can be dealt with in the same manner as a rigid wall for dynamic bearing capacity purposes.

This paper will follow Koerner's recommendation of a global factor of safety of 3.0 for external stability and 1.3 for internal stability. If either of the two external factors of safety are below 3.0, the reinforcement strips will need to be lengthened and the factor of safety will be recalculated. This will be seen more clearly in the sample problem of Chapter Three.

### **Method (B) -Modified Koerner Method.**

This is a modified method from method (A) to account for various possible seismic failure planes. The failure plane assumed by Koerner starts at the toe of the wall and extends at some angle ( $\rho$ ) from the horizontal up to the surface of the backfill (Figure 2-7). In the static case, it is the same as Rankine's value;

$$\rho = (45 + \phi/2) \quad (2.24)$$

and is constant. In the dynamic case, however, the failure plane at angle  $\rho$  is no longer assumed to be constant. It will change as the horizontal seismic coefficient ( $k_h$ ) changes.

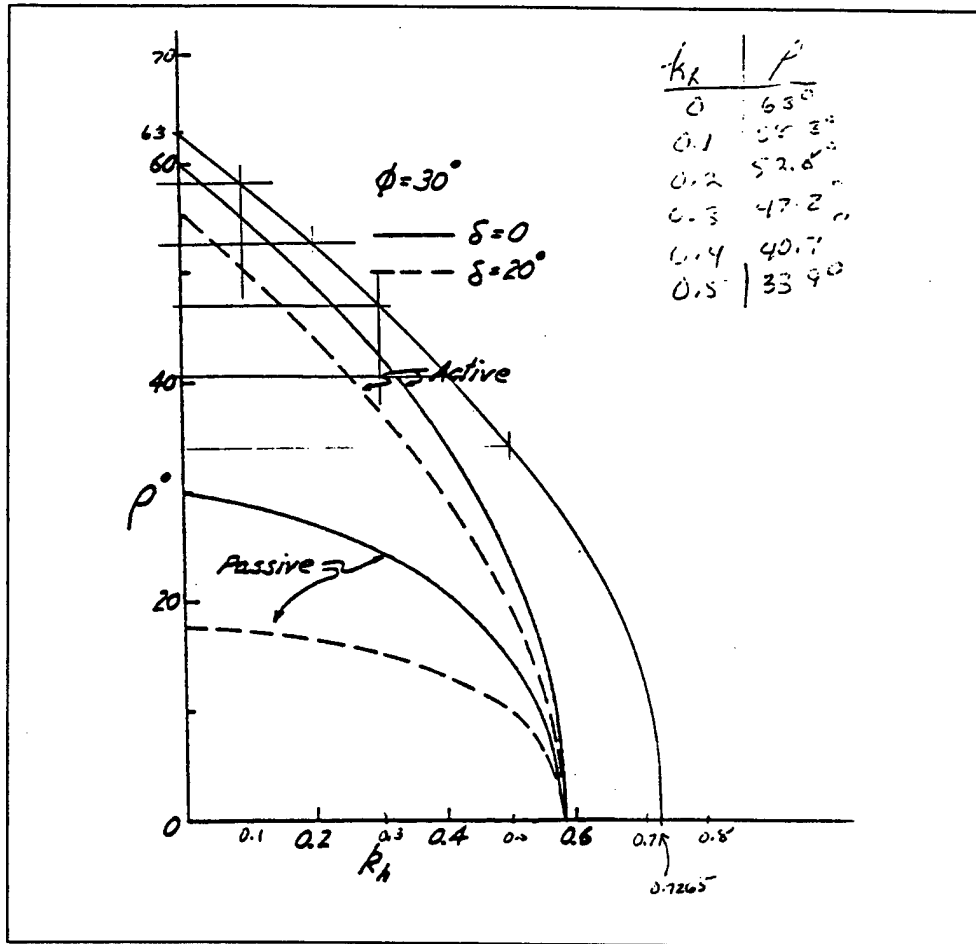

Figure 2-9: Inclination of the failure surface to the horizontal (Davies et al. 1986).

Davies et al. (1986) conducted some experiments to compare the active and passive failure planes under seismic conditions. For the purposes of this paper, a graphical extraction from  $\phi = 30^\circ$  to  $\phi = 36^\circ$  of the active curve of Davies et al. (1986)

as seen in Figure (2-9) was conducted. The  $\rho$  values for various  $k_h$  are depicted in Table (2-2). Once the value for  $\rho$  is found, Equation (2.13) becomes,

$$L_R = (H - z) \tan(90 - \rho) \quad (2.25)$$

for that particular failure plane and  $k_h$ .

All other calculations are the same as method (A).

**Table 2-2:  $\rho$  values used in method (B).**

<b>Kh</b>	<b><math>\rho</math></b>
0.0	63°
0.1	58.3°
0.2	52.8°
0.3	47.2°
0.4	40.7°
0.5	33.9°

### **Method (C) - Extended Rankine Method.**

Method (C) uses Rankine's  $P_A$  instead of Coulomb's and is extended to the dynamic case. In method (A) it was shown that Koerner applied the total earth force on the wall at an angle of  $\delta$  with the horizontal which is taken from Coulomb's method. Koerner, however, combined this with the Rankine value for  $K_A$  value, not Coulomb's  $K_A$  value. No explanation for this is given in the text, but, it is an obvious combination of two different theories. Koerner established the value of  $\delta$  to be equal

to  $\phi$  for the geosynthetic case. If the vertical line A-B in Figure 2-7 is a failure line, Koerner's assumption of  $\delta = \phi$  is a reasonable one. However, the line A-B is not a failure line, so it is more reasonable to apply Rankine type pressure with  $\delta = 0$  along the A-B boundary. Therefore, for method (C) we assume that  $\delta = 0$  and calculate the internal and external factors of safety as in method (A) with constant  $\rho = (45 + \phi/2)$ . Note that there will be no vertical component of  $P_{AE}$ , consequently this method should provide a more conservative approach.

**Method (D) - Modified Rankine Method.**

Here the method is modified, such as method (B) was, to account for the various possible seismic failure planes. The application of  $P_{AE}$  is in the Rankine mode and each failure plane is calculated separately according to  $k_h$  values in Table (2-2).

Table (2-3) illustrates the differences in the four different methods.

**Table 2-3: Rho values for design methods.**

<b>Earth Pressure</b>	<b><math>\rho = \tan(45 + \phi/2)</math></b>	<b><math>\rho</math> from Table (2-2)</b>
<b>Coulomb</b>	Method (A)	Method (B)
<b>Rankine</b>	Method (C)	Method (D)



# Chapter Three

## Sample Problem and Computational Results

### 3.1 GSRW Sample Problem

The sample problem used here is taken from Koerner (1994) with some minor changes that are non-crucial to the outcome or the theory behind the modified methods. For consistency, the geometry follows that of Figure (2-7) and is reproduced below with actual magnitudes and dimensions.

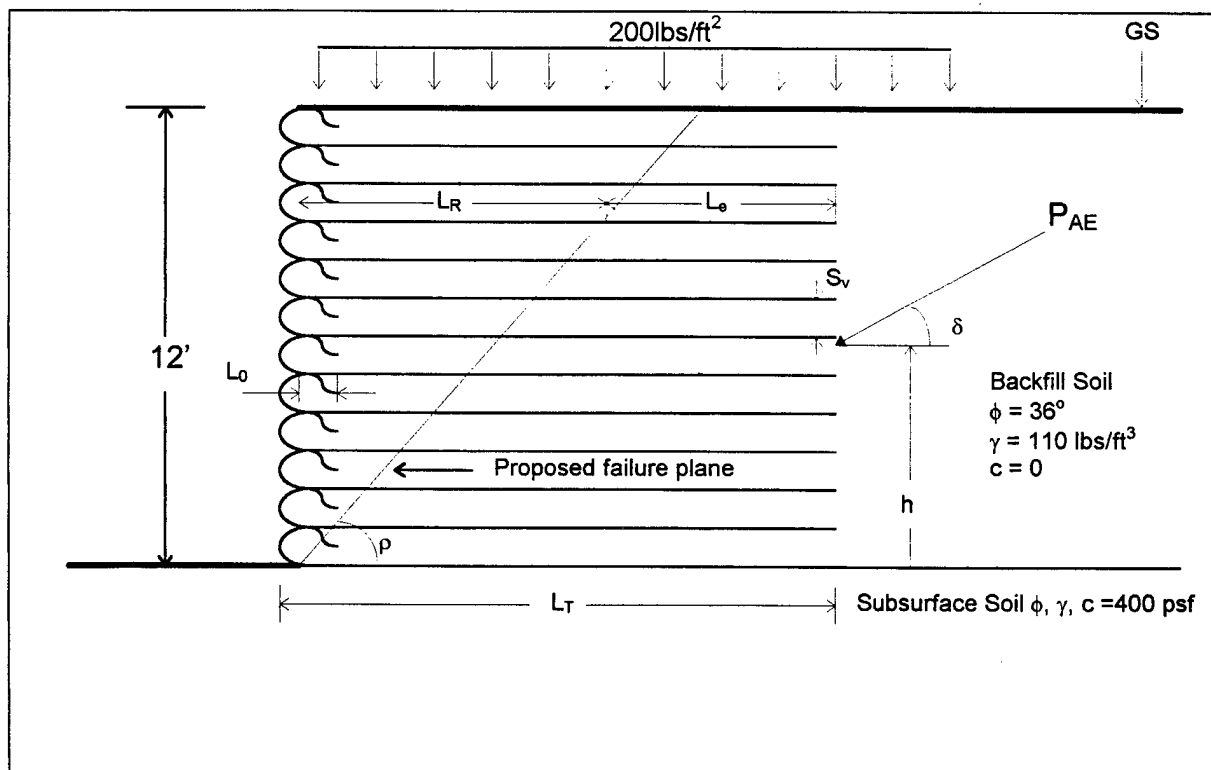

Figure 3-1: Sample problem.

Other essential data:

$\delta = 24^\circ$  (friction angle between the soil and the geosynthetic fabric)

Woven slit-film geotextile with  $T_{ult} = 250 \text{ lb/in} = 3000 \text{ lb/ft}$

$C_a = 0.8C = 320 \text{ psi}$  (subsurface soil)

Internal  $FS_g = 1.3$                       External  $FS_g = 3.0$

$FS_{ID} = 1.50$                                $FS_{CR} = 3.00$

$FS_{CD} = 1.25$                                $FS_{BD} = 1.10$

Starting with method (A), using  $K_h = 0.5$  and constant  $\rho$  for internal stability;

$$K_A = \tan^2(45 - \phi/2) = 0.2596 \quad (3.1)$$

$$K_{AE} = 0.6920 \quad (\text{from table in Das (1993) or from Equation 2.7}) \quad (3.2)$$

$$\Delta K_{dyn} = K_{AE} - K_A = 0.6920 - 0.2596 = 0.4324 \quad (3.3)$$

$$T_{allow} = \frac{T_{ult}}{FS_{ID} * FS_{CR} * FS_{CD} * FS_{BD}} = \frac{3000}{1.50 * 3.00 * 1.25 * 1.10} = 485.85 \text{ lb/ft} \quad (3.4)$$

$$\sigma_{dyn} = \sigma_q + \sigma_A + \Delta\sigma_{dyn} \quad (3.5a)$$

$$= K_{AE}q + K_A\gamma z + \Delta K_{dyn}\gamma(0.8H - 0.6z) \quad (3.5b)$$

$$= 138.4 + 28.6z + 47.6(9.6 - 0.6z) \quad (3.5c)$$

$$S_v = \frac{T_{allow}}{\sigma_{dyn} * FS_g} = \frac{484.85}{1.3[138.4 + 28.6z + 47.6(9.6 - 0.6z)]} \quad (3.6)$$

Table (3-1) yields the reinforcement spacing results for the total depth of the wall.

Table 3-1: Spacing results (blue indicates chosen design values).

Depth z (ft)	$\sigma_q$ (lb/ft <sup>2</sup> )	$\sigma_A$ (lb/ft <sup>2</sup> )	$\Delta\sigma_{dyn}$ (lb/ft <sup>2</sup> )	$\sigma_{dyn}$ (lb/ft <sup>2</sup> )	Computed $S_v$ (ft)	Design $S_v$ (ft)	Design $S_v$ (in)
0	138.40	0.0	456.6	595.0	0.63	0.580	7.0
1	138.40	28.6	428.1	595.0	0.63	0.580	7.0
2	138.40	57.1	399.5	595.0	0.63	0.580	7.0
3	138.40	85.7	371.0	595.1	0.63	0.580	7.0
4	138.40	114.2	342.5	595.1	0.63	0.580	7.0
5	138.40	142.8	313.9	595.1	0.63	0.580	7.0
6	138.40	171.3	285.4	595.1	0.63	0.580	7.0
7	138.40	199.9	256.8	595.1	0.63	0.580	7.0
8	138.40	228.4	228.3	595.2	0.63	0.580	7.0
9	138.40	257.0	199.8	595.2	0.63	0.580	7.0
10	138.40	285.6	171.2	595.2	0.63	0.580	7.0
11	138.40	314.1	142.7	595.2	0.63	0.580	7.0
12	138.40	342.7	114.2	595.2	0.63	0.580	7.0

Computed values for  $S_v$  are rounded to the closest foot increment or fraction for ease in construction. Here 0.63 feet is rounded down to 0.58 feet meaning each layer will be spaced at 7 inches, a reasonable compaction lift thickness during construction.

Next, determine the fabric lengths:

$$L_e = \frac{S_v \sigma_h (FS)}{2(c + \gamma z \tan \delta)} = \frac{S_v 1.3 [138.4 + 28.6z + 47.6(9.6 - 0.6z)]}{2(110)z \tan 24} \quad (3.7)$$

$$L_R = (H - z) \tan(90 - \rho) = (12 - z) \tan(90 - 33.9) \quad (3.8)$$

$$L_o = \frac{S_v \sigma_h (FS)}{4(c + \gamma z \tan \delta)} = \frac{1.3 S_v [138.4 + 28.6z + 47.6(9.6 - 0.6z)]}{4(110)z \tan 24} \geq 3.0' \quad (3.9)$$

Here too, a table is the most useful form:

**Table 3-2: Results for fabric length (blue indicates chosen design values).**

Layer	z (ft)	S <sub>v</sub> (ft)	L <sub>R</sub> (ft)	Calculated L <sub>c</sub> (ft)	Design L <sub>c</sub> (ft)	Calculated L <sub>t</sub> (ft)	Design L <sub>t</sub> (ft)	Calculated L <sub>o</sub> (ft)	Design L <sub>o</sub> (ft)	L <sub>c</sub>
21	0.58	0.58	5.82	5.35	5.35	11.17	12.00	2.67	3.00	15.58
20	1.16	0.58	5.52	2.71	3.00	8.52	12.00	1.36	3.00	15.58
19	1.74	0.58	5.23	1.84	3.00	8.23	12.00	0.92	3.00	15.58
18	2.32	0.58	4.93	1.40	3.00	7.93	12.00	0.70	3.00	15.58
17	2.90	0.58	4.64	1.13	3.00	7.64	12.00	0.57	3.00	15.58
16	3.48	0.58	4.34	0.96	3.00	7.34	12.00	0.48	3.00	15.58
15	4.06	0.58	4.05	0.83	3.00	7.05	12.00	0.42	3.00	15.58
14	4.64	0.58	3.75	0.74	3.00	6.75	12.00	0.37	3.00	15.58
13	5.22	0.58	3.45	0.67	3.00	6.45	12.00	0.33	3.00	15.58
12	5.80	0.58	3.16	0.61	3.00	6.16	12.00	0.30	3.00	15.58
11	6.38	0.58	2.86	0.56	3.00	5.86	6.00	0.28	3.00	9.58
10	6.96	0.58	2.57	0.52	3.00	5.57	6.00	0.26	3.00	9.58
9	7.54	0.58	2.27	0.49	3.00	5.27	6.00	0.24	3.00	9.58
8	8.12	0.58	1.98	0.46	3.00	4.98	6.00	0.23	3.00	9.58
7	8.70	0.58	1.68	0.43	3.00	4.68	6.00	0.22	3.00	9.58
6	9.28	0.58	1.39	0.41	3.00	4.39	6.00	0.20	3.00	9.58
5	9.86	0.58	1.09	0.39	3.00	4.09	6.00	0.20	3.00	9.58
4	10.44	0.58	0.79	0.37	3.00	3.79	6.00	0.19	3.00	9.58
3	11.02	0.58	0.50	0.36	3.00	3.50	6.00	0.18	3.00	9.58
2	11.60	0.58	0.20	0.34	3.00	3.20	6.00	0.17	3.00	9.58
1	12.00	0.40	0.00	0.23	3.00	3.00	6.00	0.12	3.00	9.40

The calculated values have been rounded to reasonable design values of 12 and 6 feet, hence, the retaining structure has two different lengths of fabric. L<sub>t</sub> is the sum of the resisting and non-resisting lengths of fabric. L<sub>c</sub> is the total length of the fabric including the spacing and the overlap. This completes the internal stability design with the exception of some miscellaneous details which are fairly standard and manufacture recommendations should be followed.

For external stability, overturning and sliding need to be checked. Starting with overturning about the toe, recalling the pressure distributions of Figure (2-8) and noting the geometry of Figure (3-2):

$$P_q = 138.4(12) = 1660.8 \text{ lb/ft} \quad @ 1/2H = 6 \text{ ft} \quad (3.10)$$

$$P_A = 1/2(342.7)(12) = 2056.2 \text{ lb/ft} \quad @ 1/3H = 4 \text{ ft} \quad (3.11)$$

$$P_{\text{dyn1}} = 1/2(342.4)(12) = 2054.4 \text{ lb/ft} \quad @ 2/3H = 8 \text{ ft} \quad (3.12)$$

$$\frac{P_{\text{dyn2}} = 114.2(12) = 1370.4 \text{ lb/ft}}{P_{\text{AE}} = 7141.8 \text{ lb/ft}} \quad @ 1/2H = 6 \text{ ft} \quad (3.13)$$

$$h = \frac{1/2 HP_q + 1/3 HP_A + 2/3 HP_{\text{dyn1}} + 1/2 HP_{\text{dyn2}}}{P_q + P_A + P_{\text{dyn1}} + P_{\text{dyn2}}} \quad (3.14a)$$

$$h = \frac{1660.8(6) + 2056.2(4) + 2054.4(8) + 1370.4(6)}{1660.8 + 2056.2 + 2054.4 + 1370.6} = 6.0 \text{ ft} \quad (3.14b)$$

$$P_{\text{AE}}\sin(\phi) = (7141.8)\sin(24) = 4197.8 \text{ lb/ft} \quad (3.15)$$

$$P_{\text{AE}}\cos(\phi) = (7141.8)\cos(24) = 5777.7 \text{ lb/ft} \quad (3.16)$$

$$FS_{\text{OT}} = \frac{\text{resisting moments}}{\text{driving moments}} = \frac{W_1 X_1 + W_2 X_2 + P_{\text{AE}}\sin\phi(12)}{(h)P_{\text{AE}}\cos\phi} \quad (3.17a)^7$$

$$FS_{\text{OT}} = \frac{12(5.8)110(6) + 6(6.2)110(3) + 4197.8(12)}{5777.8(6)} = 2.41 < 3.0, \text{ no good!} \quad (3.17b)$$

Try increasing bottom layers to 8 ft,  $FS_{\text{OT}} = 2.68 < 3.0$ , no good! (3.17c)

Therefore, increase bottom layers to 9 ft,  $FS_{\text{OT}} = 3.21 > 3.0$ , O.K! (3.17d)

<sup>7</sup> Refer to Figure 3-2 on the following page for the location of  $W_1$  &  $W_2$  and  $X_1$  &  $X_2$ .

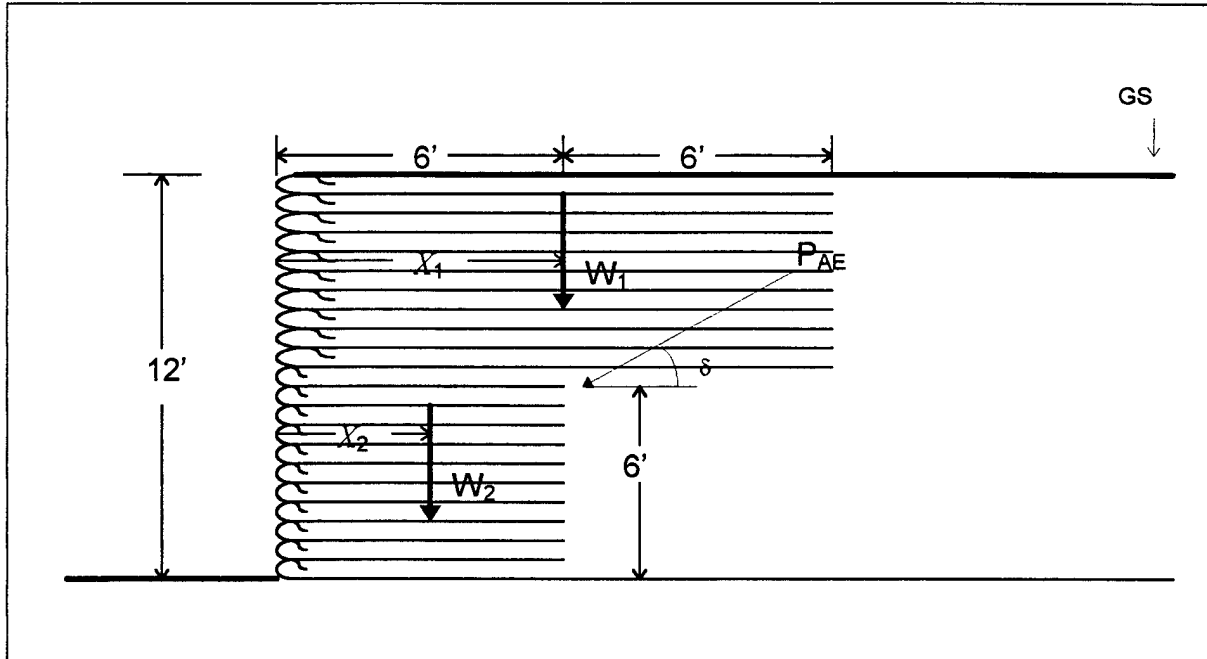

Figure 3-2: External moments.

For sliding;

$$FS_{SL} = \frac{\text{resisting forces}}{\text{driving forces}} = \frac{\left\{ Ca + \frac{(W_1 + W_2 + P_{AE} \sin \phi) \tan \delta}{L} \right\} L}{P_{AE} \cos \phi} \quad (3.18a)$$

$L = L_t$  and in this case is 9'

$$FS_{SL} = \frac{\left\{ 320 + \frac{[12(5.8)110 + 9(6.2)110 + 4197.8] \tan 24}{9} \right\} * 9}{5777.8} \quad (3.18b)$$

$$FS_{SL} = 1.88 < 3.0, \text{ no good!} \quad (3.18c)$$

Try increasing bottom layers to 12',  $FS_{SL} = 2.21 < 3.0$ , no good! (3.18d)

Consequently, increase all layers to 17',  $FS_{SL} = 3.00$ , O.K! (3.18e)

Therefore, this method defines a retaining structure made up of 21 geosynthetic layers, all spaced at 7 inches and all 17 feet long.

Method (B) uses the same process and equations as method (A) but varies the  $\rho$  angles in accordance with Table (2-2). This method provides a retaining structure consisting of 21 rows of geosynthetic material, each spaced at 7 inches, the top 3 rows will be 23 feet long and the bottom 18 rows will be 17 feet long. This method provides a more conservative design than does method (A).

Method (C) uses the Rankine pressure distribution with constant  $\rho$  angles and yields a retaining structure made up of 21 rows of geosynthetic material, each spaced at 7 inches and 24 feet long. Still even more conservative than method (B).

Method (D) uses the same process and equations as method (C), however, similar to method (B), the  $\rho$  angles vary in accordance with Table (2-2). It defines a retaining structure consisting of 21 geosynthetic rows, each spaced at 7 inches and 24 feet long. The results from method (D) are virtually indistinguishable from method (C), in this case.

### **3.2 Concrete Cantilever Retaining Wall Sample Problem**

It is essential to compare the GSRW results to some well accepted benchmark such as a cantilever concrete retaining wall (CCRW). For the purposes of this paper the CCRW shown in Figure (3-3) will be the benchmark model. Since many text

books provide the theory and rationale behind the design of concrete cantilever retaining structures, it will not be reproduced here. The reference used in this paper is from Cernica (1995). The model has been constructed to match the dimensions and geometry as close as possible to those of the GSRW in Section (3.1).

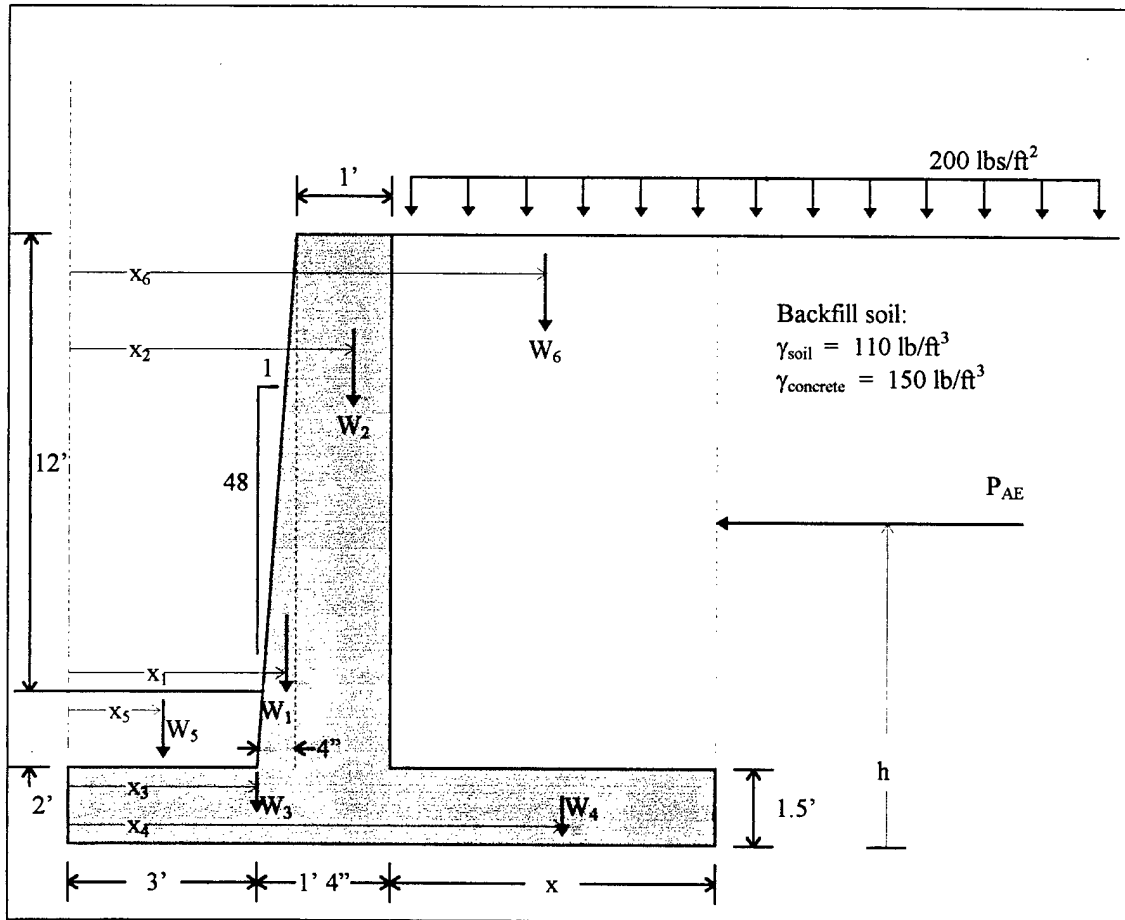

Figure 3-3: Concrete cantilever retaining wall.

The CCRW in Figure (3-3) is of typical cross-section with the front toe buried under two feet of soil. The length of the heel ( $x$ ) is left as the only variable in which to calculate the safety factor. For the seismic analysis, the passive earth pressure



resistance is neglected but the weight of the soil is not. Internal stability of the CCRW is left to other sources as it is not within the scope of this paper. As for external stability, bearing capacity is not discussed for the same reasons as it was not considered for the GSRW. Sliding, while important, will also be neglected because if it does become critical, vertical blocks on the base of the wall can be added with little difficulty and the sliding possibility is almost eliminated. Overturning remains the only external stability factor to be considered and its factor of safety is calculated in the following:

Find the weight and location of each block:

$$W_1 = 1/2(1/3)14(150) = 350 \text{ lb/ft} \quad x_1 = 3.22 \text{ ft} \quad (3.19a)$$

$$W_2 = 1(14)150 = 2100 \text{ lb/ft} \quad x_2 = 3.83 \text{ ft} \quad (3.19b)$$

$$W_3 = 1.5(4.67)150 = 1051 \text{ lb/ft} \quad x_3 = 2.17 \text{ ft} \quad (3.19c)$$

$$W_4 = 1.5(x)150 = 225x \text{ lb/ft} \quad x_4 = (4.33 + x/2) \text{ ft} \quad (3.19d)$$

$$W_5 = 110(3)2 = 660 \text{ lb/ft} \quad x_5 = 1.67 \text{ ft} \quad (3.19e)$$

$$W_6 = 14(x)110 = 1540x \text{ lb/ft} \quad x_6 = (4.33 + x/2) \text{ ft} \quad (3.19f)$$

Next, calculate the force ( $P_{AE}$ ) and the height of application ( $h$ ) for  $k_h = 0.5$  using the same format as in Figure (2-8):

$$P_q = 138.4(15.5) = 2145.4 \text{ lb/ft} @ 1/2(15.5) = 7.75 \text{ ft} \quad (3.20a)$$

$$P_A = \frac{1}{2}(28.6)15.5^2 = 3435.6 \text{ lb/ft} @ 1/3(15.5) = 5.17 \text{ ft} \quad (3.20b)$$

$$P_{\text{dyn1}} = \frac{1}{2}(447.3)15.5 = 3466.6 \text{ lb/ft} @ 2/3(15.5) = 10.30 \text{ ft} \quad (3.20c)$$

$$P_{\text{dyn2}} = 147.4(15.5) = 2284.7 \text{ lb/ft} @ 1/2(15.5) = 7.75 \text{ ft} \quad (3.20e)$$

$$P_{\text{AE}} = 11332.1 \text{ lb/ft} @ h = 7.8 \text{ ft} \quad (3.20f)^8$$

Table (3-3) shows the values for all  $k_h$ :

**Table 3-3: CCRW sample problem force values:**

$k_h$	$P_{\text{AE}}$	$h$
0.0	4240.5 lb/ft	5.7 ft
0.1	5160.4 lb/ft	6.3 ft
0.2	6419.3 lb/ft	6.8 ft
0.3	7549.3 lb/ft	7.1 ft
0.4	8725.0 lb/ft	7.4 ft
0.5	11332.1 lb/ft	7.8 ft

The factor of safety is now calculated using Equation (2.15) in the following form:

$$FS_{\text{OT}} = \frac{W_1x_1 + W_2x_2 + W_3x_3 + W_4x_4 + W_5x_5 + W_6x_6}{P_{\text{AE}}(h)} \quad (3.21a)$$

$$FS_{\text{OT}} = \frac{12552.87 + 225x\left(4.33 + \frac{x}{2}\right) + 1540x\left(4.33 + \frac{x}{2}\right)}{11332.1(7.8)} \quad (3.21b)$$

Calculation of Equation (3.21) for all values of  $k_h$  with  $FS_{\text{OT}} \cong 3.0$  leads to the following table;

<sup>8</sup> The value of (h) is calculated using Equation (2.22).

**Table 3-4: Results of the variable (x).**

$k_h$	$W_1x_1$ (lb/ft/ft)	$W_2x_2$ (lb/ft/ft)	$W_3x_3$ (lb/ft/ft)	$W_4x_4$ (lb/ft/ft)	$W_5x_5$ (lb/ft/ft)	$W_6x_6$ (lb/ft/ft)	$P_{AE}$ (lb/ft)	h (ft)	x (ft)	FS
0.5	1127	8043	2281	32462	1102	222185	11332	7.8	13.2	3.02
0.4	1127	8043	2281	23305	1102	159507	8725	7.4	10.7	3.03
0.3	1127	8043	2281	19098	1102	130718	7549.3	7.1	9.4	3.03
0.2	1127	8043	2281	15273	1102	104532	6419.3	6.8	8.1	3.03
0.1	1127	8043	2281	10843	1102	74216	5160.4	6.3	6.4	3.00
0.0	1127	8043	2281	7684	1102	52591	4240.5	5.7	5.0	3.01

Applying the values from Table (3-4) to determine concrete required yields the following values for amount of concrete per foot of wall which is required to provide a stable retaining wall.

**Table 3-4: Required concrete.**

kh	x (ft)	Concrete Required (ft <sup>3</sup> /ft)
0.5	13.2	42.63
0.4	10.7	38.88
0.3	9.4	36.93
0.2	8.1	34.98
0.1	6.4	32.43
0.0	5.0	30.33

### 3.3 Comparison of Design Methods

There are many ways in which to compare the different design methods. Notwithstanding this, it is just as important to fully understand the magnitude of the problem and how seismic influence affects the outcome. The higher the expected horizontal seismic influence, the more resistance will be required to stabilize the structure. Figure (3-4) graphically illustrates the amount of resistance required by the

retaining structure for each  $k_h$  value to remain stable. Appreciation of the magnitude that must be overcome in the design is essential to preparing the correct design with the proper procedures. Note that the amount of resistance required for  $k_h = 0.5$  is more than two and one half times that which is required for  $k_h = 0.0$ .

Of the various ways to compare the economics of the different design methods, study of the amount of fabric required is probably the most efficient. Table (3-5) shows the total amount of fabric needed per linear foot of wall<sup>9</sup>. The amount of

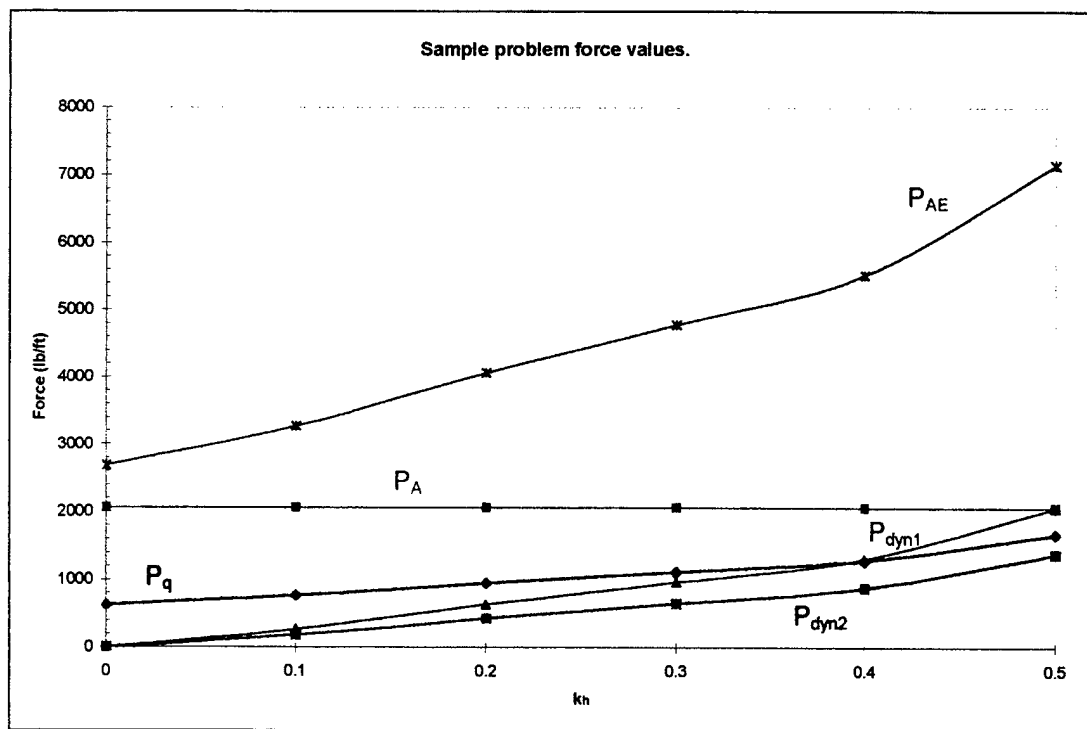

Figure 3-4: Force values, refer to Equation (2.11).

fabric in the geosynthetic reinforced retaining structure will have a direct effect on the cost to build it as will the amount of concrete required in the CCRW. A larger

<sup>9</sup> Note that the results for methods (C) and (D) are virtually indistinguishable.

amount of fabric or concrete will lead to higher material and labor costs. The majority of the increased material cost is due to the increased amount of fabric or concrete required, assuming the quantity of backfill soil used will not be effected.

**Table 3-5: Total geosynthetic and concrete material required.**

kh	GSRW Method (A) Lc (ft/ft)	GSRW Method (B) Lc (ft/ft)	GSRW Method (C) Lc (ft/ft)	GSRW Method (D) Lc (ft/ft)	CCRW Vol. (ft <sup>3</sup> /ft)
0.5	432	450	524	524	42.63
0.4	318	328	408	408	38.88
0.3	237	249	297	297	36.93
0.2	186	191	233	233	34.98
0.1	136	141	166	165	32.43
0.0	112	112	126	126	30.33

Figure (3-5) graphically illustrates the quantity of fabric required.

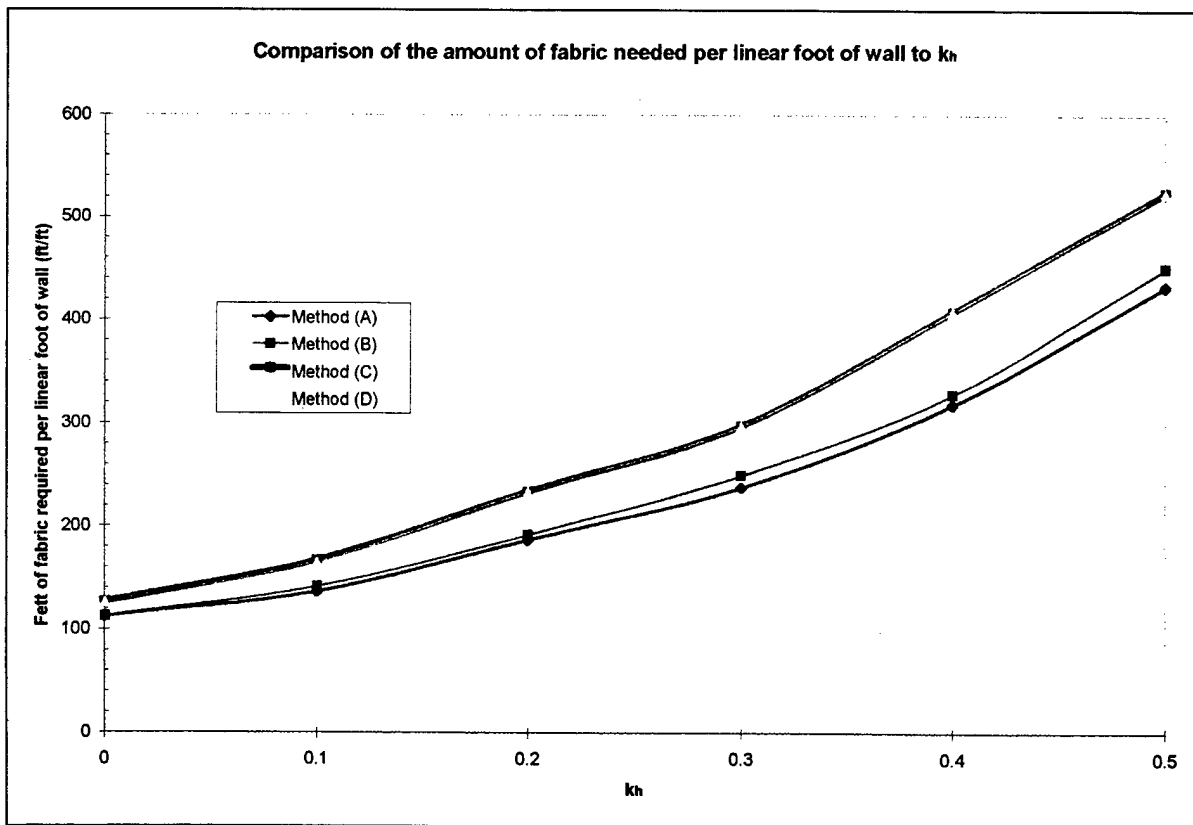

**Figure 3-5: Total amount of fabric needed:**

Labor costs will rise as more time is needed to receive, store and install the additional materials properly. Also, the size of the fabric spacing will effect how much backfill placement is permitted at one time. The sample problem sets the spacing at 7 inches. This requires each lift to be 7 inches as well and limits the contractor when they can normally handle a 12 to 14 inch lift, possibly extending the entire job duration by 30% to 50%. Other cost increases such as training, quality control and disposal procedures will also add to the project, however, they are fixed costs.

Other ways of comparing the design methods are to compare the minimum and maximum spacing requirements and the minimum and maximum length of the reinforcement layers. Figure (3-6) shows the computed range of spacing as compared

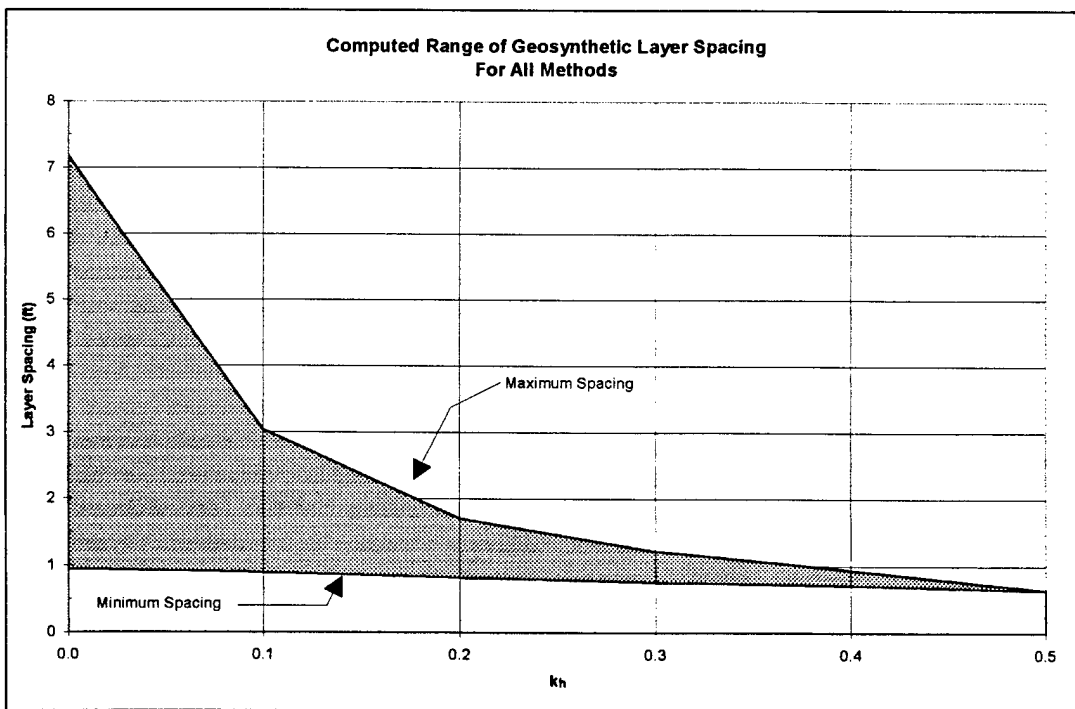

Figure 3-6: Computed range of geosynthetic spacing.

to  $k_h$ . Note the large range at  $k_h = 0.0$  and narrow range at  $k_h = 0.5$ . This means that the designer has very little room for decision making when the seismic influence is high. Figure (3-7) shows how the computed spacing ranges for the sample problem are narrowed for the finish design. The range of spacing is no larger than one foot for low seismic values and reduces to zero at high seismic values.

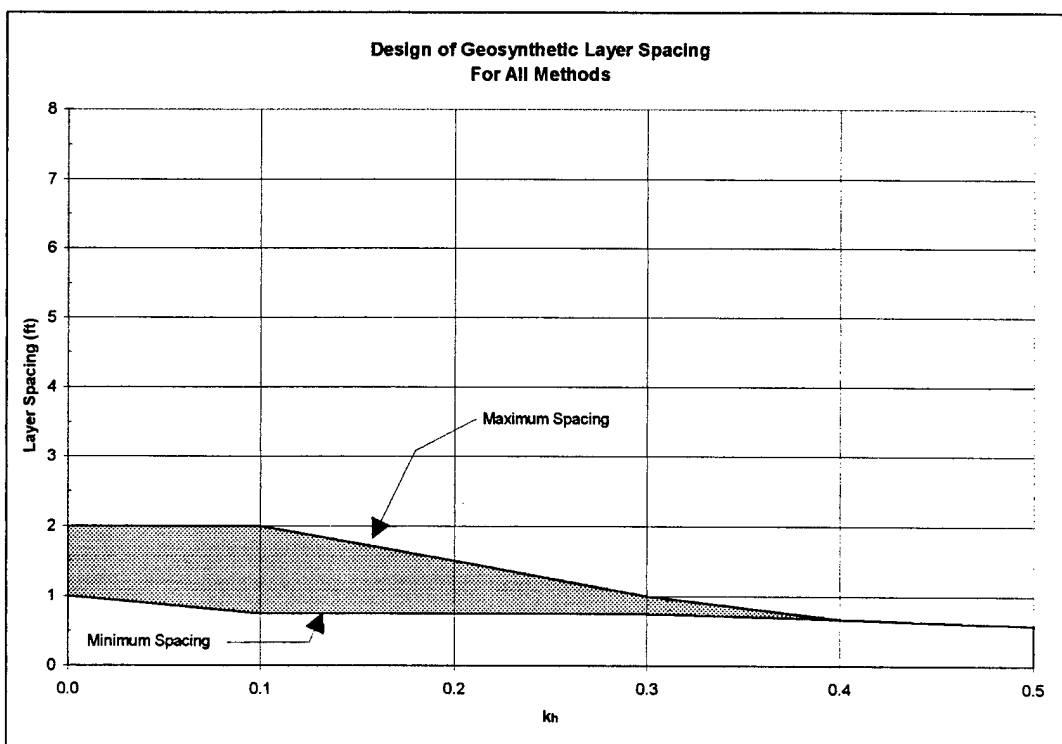

Figure 3-7: Design range of geosynthetic spacing.

The maximum and minimum reinforcement lengths most likely will not provide additional information as to which design method is most appropriate. There is no way to interpret these results for design purposes other than to determine if the retaining structure will fit into certain dimensional site limitations. By maximum and minimum lengths, we mean the total length the reinforcement layer extends from the

face of the wall, horizontally into the retaining structure (from left to right in Figure 3-2). Figure (3-8) shows the minimum reinforcement lengths needed for each method and Figure (3-9) shows the maximum.

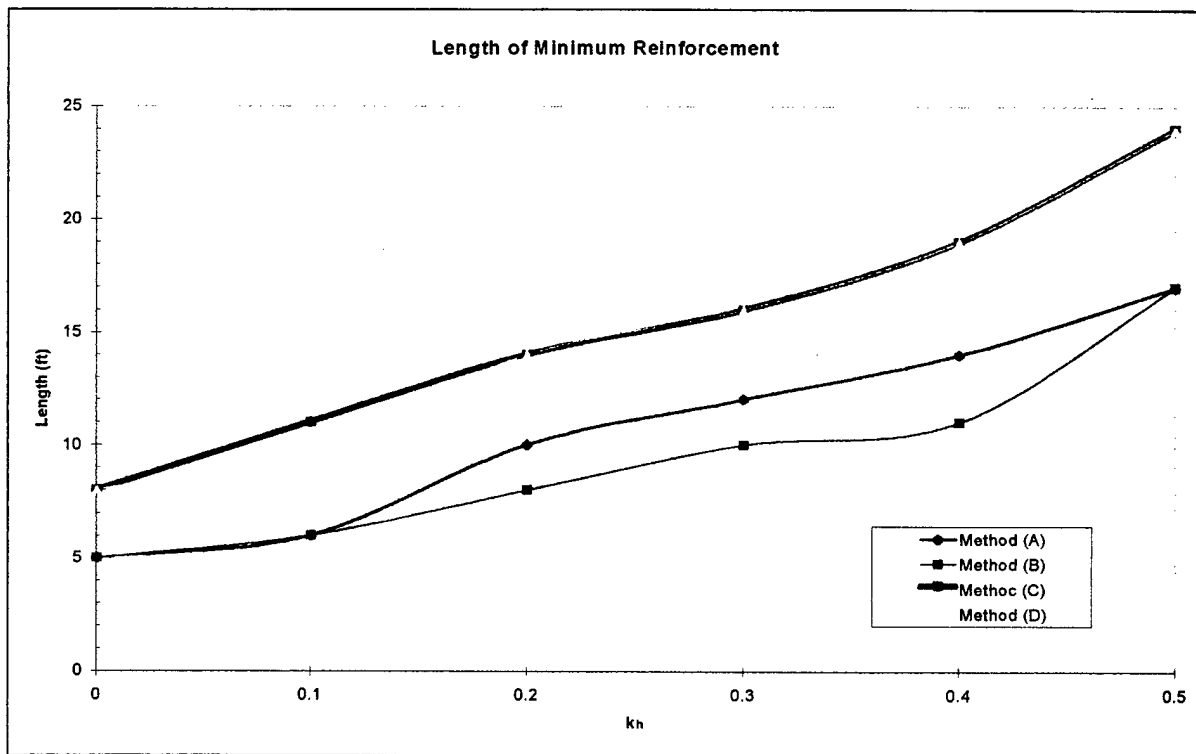

Figure 3-8: Minimum reinforcement lengths.

Another means of judging the GSRW is to compare it to the results for the CCRW. Figure (3-10) graphically shows all four of the geosynthetic methods, the concrete wall design method and the amount of resistance required to maintain stability.



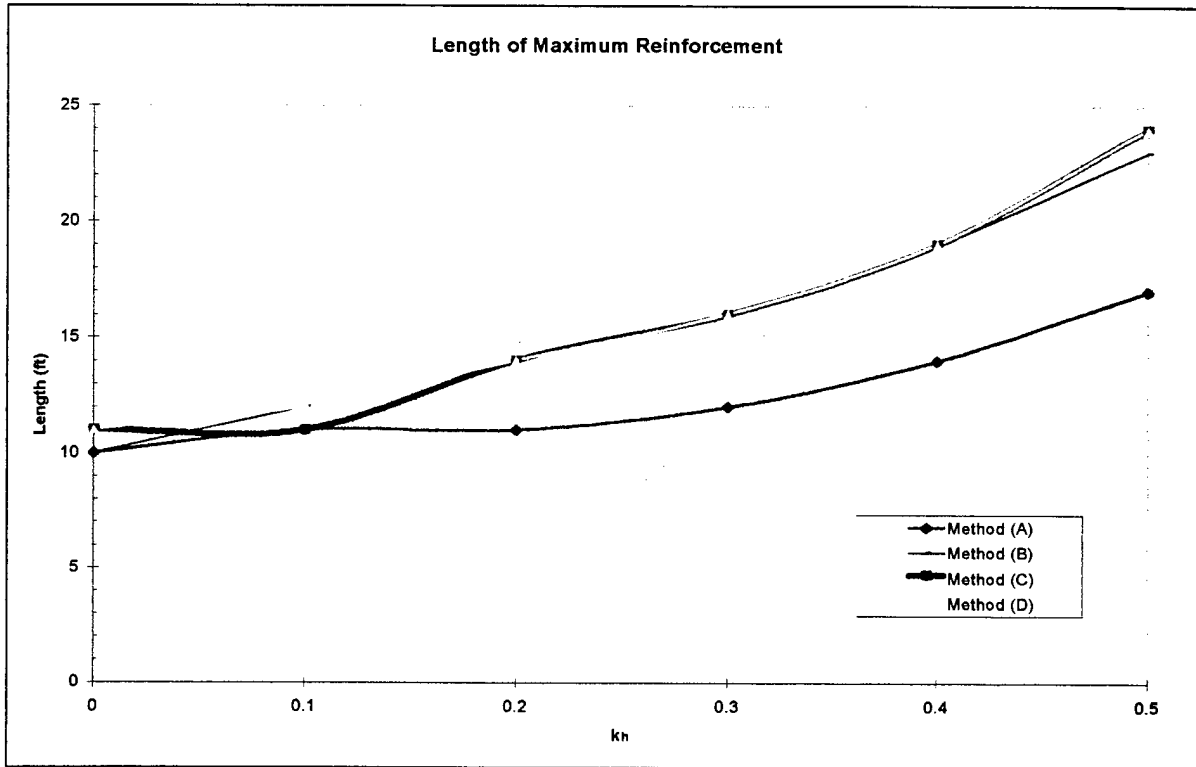

Figure 3-9: Maximum reinforcement lengths.

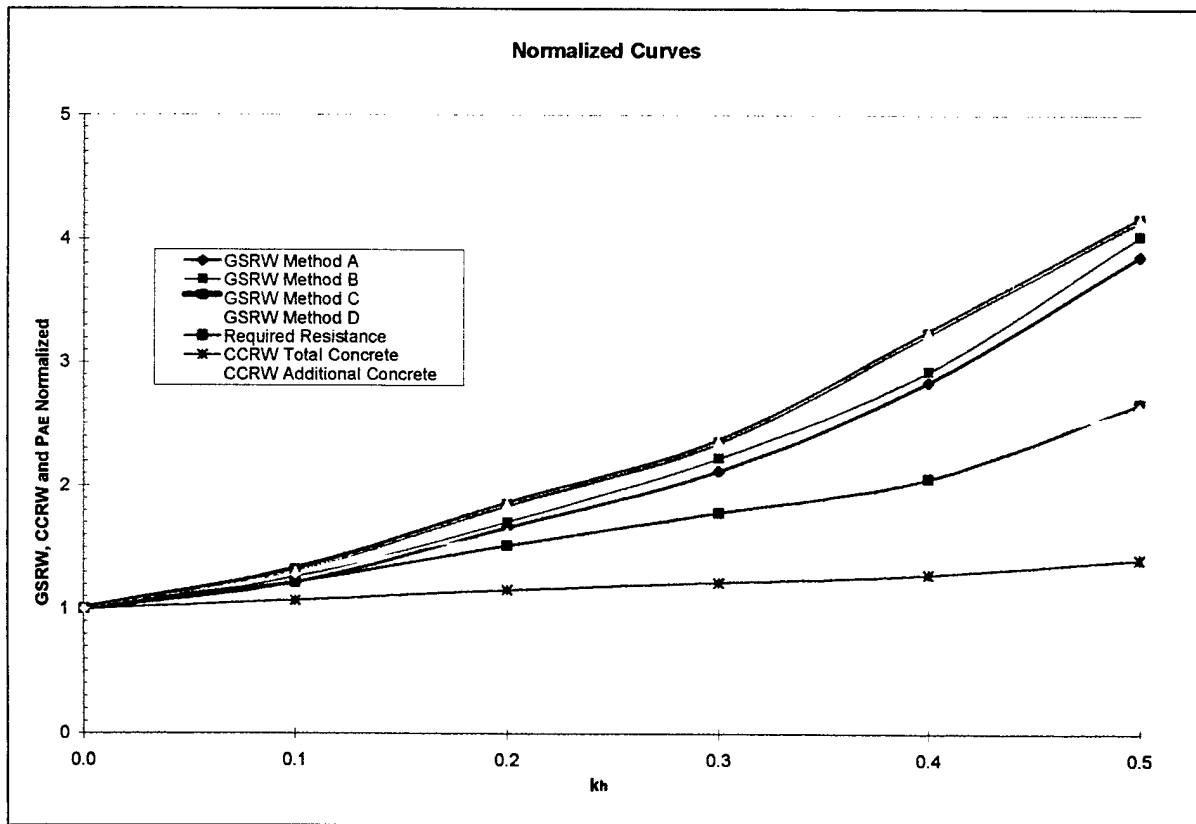

Figure 3-10: Normalized curves.

All the curves have been normalized against their respective values at  $k_h = 0.0$ . Note that all of the curves for the GSRW increase much more rapidly than does the  $P_{AE}$  curve. For the CCRW method, total concrete required for the entire wall section is affected much less than the additional length required on the heel of the CCRW. From Figure (3-10), it seems that CCRW construction is more economically favorable against higher seismic loads in comparison to GSRW construction. However, it shall be noted that additional internal steel reinforcement normally required of CCRW in the dynamic case is totally ignored in the analysis. For a proper design, the entire concrete structure, complete with steel reinforcement, would be required.

## CHAPTER FOUR

### Summary and Conclusions

Based on the theories and procedures described in Chapter Two, a method for designing a geosynthetic reinforced retaining structure that is resistant to seismic conditions was developed in Chapter Three. The method follows a pseudo-static approach that when applied properly, can be used to create a reliable design of the GSRW against dynamic forces. It is important to note that the designer must have some idea as to what magnitude of seismic influences are anticipated before this method can be used effectively.

The choice as to which method to use is largely left to the designer. Any of the four methods will safely produce the required design. However, as noted in Chapter Two, it is not the best idea to combine the theories of two different pressure distributions such as in the Rankine theory and the Coulomb theory. Obviously, the Rankine methods are going to prove to be the most conservative because Rankine places the force ( $P_A$ ) at an angle of  $\delta = 0$  from the horizontal as opposed to Coulomb's method where  $\delta$  is greater than zero. For design of most facilities, the author recommends using the Rankine pressure distribution method with varying values of  $\rho$  as described in Method (D). It is the most detailed method and provides a slightly more conservative design than the other methods do. Also, since this method uses

only one theory to control the application of  $P_{AE}$  and defines the angle of the failure plane as well as its location, it is considered the most rational of the four methods. The author further notes that serious consideration can therefore be given to reducing the factor of safety from 3.0 to 2.0 for most cases<sup>10</sup>.

It is extremely important to realized that these methods have been developed without the benefit of field or laboratory testing. Full scale structures need to be constructed and tested under seismic loads to ensure compatibility with the above design procedures. This should be completed and documented prior to actually using the procedures outlined here.

As for which type of structure, geosynthetic or concrete, is best for a given application, economics will most likely be the governing factor. It has been shown here that either material can be safely used, therefore, further research into the cost of building the two structures must be complete for a full understanding of the impact of each. Current concrete technology is well established and has proven itself time and again. Geosynthetic use, however, is still in its infancy and will require extensive testing before it is widely accepted as a viable replacement for the more traditional construction methods.

---

<sup>10</sup> Cernica (1995) recommends  $FS = 2.0$  for cohesive soils and  $FS = 1.5$  for cohesionless soils.

## Bibliography

- Bathurst, R.J. and Cai, Z. (1995), "*Pseudo-Static Seismic Analysis of Geosynthetic-Reinforced Segmental Retaining Walls*," *Geosynthetics International*, Vol.2, No. 5, pp. 787-830.
- Cascone, E., Maugeri, M. and Motta, E. (1995), "*Seismic Design of Earth-Reinforced Embankments*," from "Proceedings of IS-Tokyo '95, The First International Conference on Earthquake Geotechnical Engineering," Tokyo, Japan.
- Cernica, J.N. (1995), "*Geotechnical Engineering Foundation Design*," John Wiley & Sons, Inc., New York, NY.
- Das, B.M. (1983), "*Principles of Soil Dynamics*," PWS-Kent Publishing Company, Boston, MA.
- Davies, T.G., Richards, R. Jr. and Chen, K.-H. (1996), "*Passive Pressure During Seismic Loading*," *Journal of Geotechnical Engineering Division, ASCE*, Vol. 112, No. 4, pp.479-483
- Dunn, I.S., Anderson, L.R. and Kiefer, F.W. (1980), "*Fundamentals of Geotechnical Analysis*," John Wiley & Sons, Inc., New York, NY.
- Finn, W.D.L., Yogendrakumar, M. and Yoshida, H. (1986), "*TARA-3 Program to Compute the Response of 2-D embankments and Soil-Structure Interaction Systems to Seismic Loading*," Department of Civil Engineering, University of British Columbia, Vancouver, Canada.
- Ichihara, M. (1969), "*Soil Mechanics*" (in Japanese), T. Mogami, editor, Gihodo, Tokyo, Japan.
- Ishibashi, I. and Fang, Y.-S., (1987), "*Dynamic Earth Pressures with Different Wall Movement Modes*," *Soils and Foundations, Japanese Society of Soil Mechanics and Foundation Engineering*, Vol.27, No. 4 pp.11-22.
- Koerner, R.M. (1994), "*Designing With Geosynthetics -Third Edition*," Prentice Hall, Inc., Upper Saddle River, NJ.
- Richardson, G.N. (1976), "*The Seismic Design of Reinforced Earthwalls*," Natural Science Foundation, School of Engineering and Applied Science, UCLA, Los Angeles, CA.
- Richardson, G.N. and Lee, K.L. (1975), "*Seismic Design of Reinforced Earth Walls*," *Journal of Geotechnical Engineering Division, ASCE*, Vol. 101, p.167-188
- Tateyama, M., Tatsouka, F., Koseki, J. and Horii, K. (1995), "*Damage to Soil Retaining Walls for Railway Embankments During the Great Hanshin-Awaji Earthquake, January 17, 1995*," from "Proceedings of IS-Tokyo '95, The First International Conference on Earthquake Geotechnical Engineering," Tokyo, Japan
- Tatsouka, F., Koseki, J. and Tateyama, M. (1995), "*Performance of Geogrid-Reinforced Soil Retaining Walls During the Great Hanshin-Awaji Earthquake, January 17, 1995*," from "Proceedings of IS-Tokyo '95, The First International Conference on Earthquake Geotechnical Engineering," Tokyo, Japan.

Yogendrakumar, M., Bathurst, R.J. and Finn, W.D.L. (1992), "*Dynamic Response Analysis of Reinforced-Soil retaining Walls*," Journal of Geotechnical Engineering Division, ASCE Vol. 118, August 1992.

## APPENDIX A

# Extended Koerner method

(A)

$$k_h = 0.5$$

$$L_R = (H - z) \tan(45 - \phi/c)$$

Depth z (ft)	Sigma q (lb/ft^2)	Sigma s (lb/ft^2)	Delta Sigma dyn (lb/ft^2)	SIGMA d (lb/ft^2)	Sv (ft)	Sv Use (ft)	Sv Use (Inch)
0	138.40	0.0	456.6	595.0	0.63	0.580	7.0
1	138.40	28.6	428.1	595.0	0.63	0.580	7.0
2	138.40	57.1	399.5	595.0	0.63	0.580	7.0
3	138.40	85.7	371.0	595.1	0.63	0.580	7.0
4	138.40	114.2	342.5	595.1	0.63	0.580	7.0
5	138.40	142.8	313.9	595.1	0.63	0.580	7.0
6	138.40	171.3	285.4	595.1	0.63	0.580	7.0
7	138.40	199.9	256.8	595.1	0.63	0.580	7.0
8	138.40	228.4	228.3	595.2	0.63	0.580	7.0
9	138.40	257.0	199.8	595.2	0.63	0.580	7.0
10	138.40	285.6	171.2	595.2	0.63	0.580	7.0
11	138.40	314.1	142.7	595.2	0.63	0.580	7.0
12	138.40	342.7	114.2	595.2	0.63	0.580	7.0

Layer No.	Depth z (ft)	Spacing Sv (ft)	Nonresisting Length	Resisting Length		Total Embedment Length		Overlap Length		Cut Length Lc (ft)
			Lr (ft)	Le (calc) (ft)	Le (min) (ft)	Lt (calc) (ft)	Lt (use) (ft)	Lo (calc) (ft)	Lo (use) (ft)	
21	0.58	0.58	5.82	5.35	5.35	11.17	12.00	2.67	3.00	15.58
20	1.16	0.58	5.52	2.71	3.00	8.52	12.00	1.36	3.00	15.58
19	1.74	0.58	5.23	1.84	3.00	8.23	12.00	0.92	3.00	15.58
18	2.32	0.58	4.93	1.40	3.00	7.93	12.00	0.70	3.00	15.58
17	2.90	0.58	4.64	1.13	3.00	7.64	12.00	0.57	3.00	15.58
16	3.48	0.58	4.34	0.96	3.00	7.34	12.00	0.48	3.00	15.58
15	4.06	0.58	4.05	0.83	3.00	7.05	12.00	0.42	3.00	15.58
14	4.64	0.58	3.75	0.74	3.00	6.75	12.00	0.37	3.00	15.58
13	5.22	0.58	3.45	0.67	3.00	6.45	12.00	0.33	3.00	15.58
12	5.80	0.58	3.16	0.61	3.00	6.16	12.00	0.30	3.00	15.58
11	6.38	0.58	2.86	0.56	3.00	5.86	6.00	0.28	3.00	9.58
10	6.96	0.58	2.57	0.52	3.00	5.57	6.00	0.26	3.00	9.58
9	7.54	0.58	2.27	0.49	3.00	5.27	6.00	0.24	3.00	9.58
8	8.12	0.58	1.98	0.46	3.00	4.98	6.00	0.23	3.00	9.58
7	8.70	0.58	1.68	0.43	3.00	4.68	6.00	0.22	3.00	9.58
6	9.28	0.58	1.39	0.41	3.00	4.39	6.00	0.20	3.00	9.58
5	9.86	0.58	1.09	0.39	3.00	4.09	6.00	0.20	3.00	9.58
4	10.44	0.58	0.79	0.37	3.00	3.79	6.00	0.19	3.00	9.58
3	11.02	0.58	0.50	0.36	3.00	3.50	6.00	0.18	3.00	9.58
2	11.60	0.58	0.20	0.34	3.00	3.20	6.00	0.17	3.00	9.58
1	12.00	0.40	0.00	0.23	3.00	3.00	6.00	0.12	3.00	9.40



### Overturning

$$\begin{aligned} P_g &= 138.4(2) = 1660.8 & \text{ⓐ} & 6 \\ P_a &= \frac{1}{2}(342.7)(12) = 2056.2 & \text{ⓐ} & 4 \\ P_{dyn1} &= \frac{1}{2}(942.4)(12) = 2054.4 & \text{ⓐ} & 8 \\ P_{dyn2} &= 114.2(12) = \underline{1307.4} & \text{ⓐ} & \underline{6} \\ P_{ac} &= 7141.8 & \text{ⓐ} & h = 6.0 \end{aligned}$$

$$P_{ac} \sin \phi = 4197.8$$

$$P_{ac} \cos \phi = 5777.8$$

$$\begin{aligned} FS_{OT} &= \frac{W_1 \gamma_1 + W_2 \gamma_2 + P_{ac} \sin \phi (12)}{P_{ac} \cos \phi (h)} \\ &= \frac{6(6.2)(110)(3) + 12(5.8)(110)(6) + 4197.8(6)}{5777.8(6)} = 2.41 < 3 \text{ NO} \\ & \text{good} \end{aligned}$$

increase bottom layers to 9'

$$FS_{OT} = 3.21 > 3 \text{ OK}$$

### Sliding

$$FS_S = \frac{320 + \frac{(9(6.2)(110) + 12(5.8)(110) + 4197.8) + 224}{9}}{5777.8} = 1.88 < 3$$

NO good

increase bottom layers to 17'

$$FS_S = 3.0 \text{ OK!}$$

Layer No.	Depth z (ft)	Spacing Sv (ft)	Embedment	Overlap	Cut
			Length Lt (ft)	Length Lo (ft)	Length Lc (ft)
21	0.58	0.58	17.00	3	20.58
20	1.16	0.58	17.00	3	20.58
19	1.74	0.58	17.00	3	20.58
18	2.32	0.58	17.00	3	20.58
17	2.90	0.58	17.00	3	20.58
16	3.48	0.58	17.00	3	20.58
15	4.06	0.58	17.00	3	20.58
14	4.64	0.58	17.00	3	20.58
13	5.22	0.58	17.00	3	20.58
12	5.80	0.58	17.00	3	20.58
11	6.38	0.58	17.00	3	20.58
10	6.96	0.58	17.00	3	20.58
9	7.54	0.58	17.00	3	20.58
8	8.12	0.58	17.00	3	20.58
7	8.70	0.58	17.00	3	20.58
6	9.28	0.58	17.00	3	20.58
5	9.86	0.58	17.00	3	20.58
4	10.44	0.58	17.00	3	20.58
3	11.02	0.58	17.00	3	20.58
2	11.60	0.58	17.00	3	20.58
1	12.00	0.58	17.00	3	20.58
<b>Total Fabric Length per Linear foot of wall (ft/ft)</b>					<b>432.18</b>

# Extended Koerner method

(A)

$$k_R = 0.4$$

$$L_R = (1+z) \sqrt{45 - \phi/2}$$

Depth z (ft)	Sigma q (lb/ft <sup>2</sup> )	Sigma s (lb/ft <sup>2</sup> )	Delta Sigma dyn (lb/ft <sup>2</sup> )	SIGMA d (lb/ft <sup>2</sup> )	Sv (ft)	Sv Use (ft)	Sv Use (inch)
0	106.90	0.0	290.3	397.2	0.94	0.667	8.0
1	106.90	28.6	272.2	407.6	0.91	0.667	8.0
2	106.90	57.1	254.0	418.0	0.89	0.667	8.0
3	106.90	85.7	235.9	428.4	0.87	0.667	8.0
4	106.90	114.2	217.7	438.8	0.85	0.667	8.0
5	106.90	142.8	199.6	449.3	0.83	0.667	8.0
6	106.90	171.3	181.4	459.7	0.81	0.667	8.0
7	106.90	199.9	163.3	470.1	0.79	0.667	8.0
8	106.90	228.4	145.1	480.5	0.78	0.667	8.0
9	106.90	257.0	127.0	490.9	0.76	0.667	8.0
10	106.90	285.6	108.9	501.3	0.74	0.667	8.0
11	106.90	314.1	90.7	511.7	0.73	0.667	8.0
12	106.90	342.7	72.6	522.1	0.71	0.667	8.0

Layer No.	Depth z (ft)	Spacing Sv (ft)	Nonresisting Length		Resisting Length		Total Embedment Length		Overlap Length		Cut Length
			Lr (ft)	Le (calc) (ft)	Le (min) (ft)	Lt (calc) (ft)	Lt (use) (ft)	Lo (calc) (ft)	Lo (use) (ft)	Lc (ft)	
18	0.67	0.67	5.77	5.36	5.36	11.13	12.00	2.68	3.00	15.67	
17	1.34	0.67	5.43	2.73	3.00	8.43	12.00	1.36	3.00	15.67	
16	2.01	0.67	5.09	1.85	3.00	8.09	12.00	0.92	3.00	15.67	
15	2.68	0.67	4.75	1.41	3.00	7.75	12.00	0.70	3.00	15.67	
14	3.35	0.67	4.41	1.15	3.00	7.41	12.00	0.57	3.00	15.67	
13	4.02	0.67	4.07	0.97	3.00	7.07	12.00	0.49	3.00	15.67	
12	4.69	0.67	3.72	0.85	3.00	6.72	12.00	0.42	3.00	15.67	
11	5.36	0.67	3.38	0.75	3.00	6.38	12.00	0.38	3.00	15.67	
10	6.03	0.67	3.04	0.68	3.00	6.04	12.00	0.34	3.00	15.67	
9	6.70	0.67	2.70	0.62	3.00	5.70	6.00	0.31	3.00	9.67	
8	7.37	0.67	2.36	0.57	3.00	5.36	6.00	0.29	3.00	9.67	
7	8.04	0.67	2.02	0.53	3.00	5.02	6.00	0.27	3.00	9.67	
6	8.71	0.67	1.68	0.50	3.00	4.68	6.00	0.25	3.00	9.67	
5	9.38	0.67	1.33	0.47	3.00	4.33	6.00	0.23	3.00	9.67	
4	10.05	0.67	0.99	0.44	3.00	3.99	6.00	0.22	3.00	9.67	
3	10.72	0.67	0.65	0.42	3.00	3.65	6.00	0.21	3.00	9.67	
2	11.39	0.67	0.31	0.40	3.00	3.31	6.00	0.20	3.00	9.67	
1	12.00	0.67	0.00	0.39	3.00	3.00	6.00	0.19	3.00	9.67	

## Overturning

$P_g =$	1282.8	(a)	6'
$P_a =$	2056	(b)	4'
$P_{dyn.} =$	1306.2	(a)	8'
$P_{dyn.} =$	871.2	(a)	6'
	<u>5516.2</u>	(a)	<u>5.73'</u>

$$P_{ac} \sin \phi = 3242.4 \quad P_{ac} \cos \phi = 4462.7$$

$$FS_{OT} = \frac{6(5.97)(110)(3) + 12(6.03)(110)(6) + 3242.4(3)}{4462.7(5.73)} = 2.71 < 3$$

NO good!

NO good extend bottom layers to 8'

$$FS_{OT} = 3.0 \text{ OK}$$

$$FS_{SL} = \frac{\left( 320 + \frac{+ 3242.4}{8} + \frac{8(5.97)(110) + 12(6.03)(110)}{8} \right) \tan 24}{4462.7} = 2.22 < 3$$

NO good

increase all layers to 14'

$$FS_{SL} = 3.17 > 3 \text{ OK}$$

Layer No.	Depth z (ft)	Spacing Sv (ft)	Embedment	Overlap	Cut
			Length Lt (ft)	Length Lo (ft)	Length Lc (ft)
18	0.67	0.67	14	3	17.67
17	1.34	0.67	14	3	17.67
16	2.01	0.67	14	3	17.67
15	2.68	0.67	14	3	17.67
14	3.35	0.67	14	3	17.67
13	4.02	0.67	14	3	17.67
12	4.69	0.67	14	3	17.67
11	5.36	0.67	14	3	17.67
10	6.03	0.67	14	3	17.67
9	6.70	0.67	14	3	17.67
8	7.37	0.67	14	3	17.67
7	8.04	0.67	14	3	17.67
6	8.71	0.67	14	3	17.67
5	9.38	0.67	14	3	17.67
4	10.05	0.67	14	3	17.67
3	10.72	0.67	14	3	17.67
2	11.39	0.67	14	3	17.67
1	12.00	0.67	14	3	17.67
<b>Total Fabric Length per Linear foot of wall (ft/ft)</b>					<b>318.06</b>

Extended Koerner method

(A)

$$k_x = 0.3$$

$$L_R = (H - z) \tan(45 - \phi/2)$$

Depth z (ft)	Sigma q (lb/ft <sup>2</sup> )	Sigma s (lb/ft <sup>2</sup> )	Delta Sigma dyn (lb/ft <sup>2</sup> )	SIGMA d (lb/ft <sup>2</sup> )	Sv (ft)	Sv Use (ft)	Sv Use (inch)
0	92.48	0.0	214.2	306.6	1.22	1.000	12.0
1	92.48	28.6	200.8	321.8	1.16	1.000	12.0
2	92.48	57.1	187.4	337.0	1.11	1.000	12.0
3	92.48	85.7	174.0	352.2	1.06	1.000	12.0
4	92.48	114.2	160.6	367.3	1.02	1.000	12.0
5	92.48	142.8	147.2	382.5	0.98	0.750	9.0
6	92.48	171.3	133.8	397.7	0.94	0.750	9.0
7	92.48	199.9	120.5	412.8	0.90	0.750	9.0
8	92.48	228.4	107.1	428.0	0.87	0.750	9.0
9	92.48	257.0	93.7	443.2	0.84	0.750	9.0
10	92.48	285.6	80.3	458.3	0.81	0.750	9.0
11	92.48	314.1	66.9	473.5	0.79	0.750	9.0
12	92.48	342.7	53.5	488.7	0.76	0.750	9.0

Layer No.	Depth z (ft)	Spacing Sv (ft)	Nonresisting Length	Resisting Length		Total Embedment Length		Overlap Length		Cut Length
			Lr (ft)	Le (calc) (ft)	Le (min) (ft)	Lt (calc) (ft)	Lt (use) (ft)	Lo (calc) (ft)	Lo (use) (ft)	Lc (ft)
15	1.00	1.00	5.60	5.41	5.41	11.01	11.00	2.70	3.00	15.00
14	2.00	1.00	5.10	2.77	3.00	8.10	11.00	1.39	3.00	15.00
13	3.00	1.00	4.59	1.89	3.00	7.59	11.00	0.95	3.00	15.00
12	4.00	1.00	4.08	1.46	3.00	7.08	11.00	0.73	3.00	15.00
11	4.75	0.75	3.69	0.94	3.00	6.69	11.00	0.47	3.00	14.75
10	5.50	0.75	3.31	0.82	3.00	6.31	11.00	0.41	3.00	14.75
9	6.25	0.75	2.93	0.74	3.00	5.93	6.00	0.37	3.00	9.75
8	7.00	0.75	2.55	0.67	3.00	5.55	6.00	0.33	3.00	9.75
7	7.75	0.75	2.17	0.61	3.00	5.17	6.00	0.31	3.00	9.75
6	8.50	0.75	1.78	0.57	3.00	4.78	6.00	0.28	3.00	9.75
5	9.25	0.75	1.40	0.53	3.00	4.40	6.00	0.27	3.00	9.75
4	10.00	0.75	1.02	0.50	3.00	4.02	6.00	0.25	3.00	9.75
3	10.75	0.75	0.64	0.47	3.00	3.64	6.00	0.24	3.00	9.75
2	11.50	0.75	0.25	0.45	3.00	3.25	6.00	0.22	3.00	9.75
1	12.00	0.50	0.00	0.29	3.00	3.00	6.00	0.14	3.00	9.50

### Overturning

$$P_{ae} = 4773.0$$

$$h = 5.574'$$

$$P_{ae} \sin \phi = 2805.5$$

$$P_{ae} \cos \phi = 3861.4$$

$$FS_{OT} = \frac{5.5(11)(110)(5.5) + 6.5(2)(110)(2) + 2805.5(3)}{3861.4(5.574)} \quad 3.36 \quad \text{OK!}$$

### Sliding

$$FS_{SL} = \frac{\left( 320 + \frac{5.5(11)(110) + 6.5(2)(110) + 2805.5}{6} + 24 \right) 6}{3861.4} = 2.08 \quad \text{NO GOOD!}$$

increase ALL layers to 12'

$$FS_{SL} = 3.14$$

Layer No.	Depth z (ft)	Spacing Sv (ft)	Embedment	Overlap	Cut
			Length Lt (ft)	Length Lo (ft)	Length Lc (ft)
15	1.00	1.00	12	3	16.00
14	2.00	1.00	12	3	16.00
13	3.00	1.00	12	3	16.00
12	4.00	1.00	12	3	16.00
11	4.75	0.75	12	3	15.75
10	5.50	0.75	12	3	15.75
9	6.25	0.75	12	3	15.75
8	7.00	0.75	12	3	15.75
7	7.75	0.75	12	3	15.75
6	8.50	0.75	12	3	15.75
5	9.25	0.75	12	3	15.75
4	10.00	0.75	12	3	15.75
3	10.75	0.75	12	3	15.75
2	11.50	0.75	12	3	15.75
1	12.00	0.50	12	3	15.50
<b>Total Fabric Length per Linear foot of wall (ft/ft)</b>					<b>237.00</b>



# Extended Koerner Method

(A)

$$k_f = 0.2$$

$$L_e = (H - z) \tan(45 - \phi/2)$$

Depth z (ft)	Sigma q (lb/ft <sup>2</sup> )	Sigma s (lb/ft <sup>2</sup> )	Delta Sigma dyn (lb/ft <sup>2</sup> )	SIGMA d (lb/ft <sup>2</sup> )	Sv (ft)	Sv Use (ft)	Sv Use (inch)
0	78.64	0.0	141.1	219.7	1.70	1.500	18.0
1	78.64	28.6	132.3	239.5	1.56	1.500	18.0
2	78.64	57.1	123.4	259.2	1.44	1.000	12.0
3	78.64	85.7	114.6	278.9	1.34	1.000	12.0
4	78.64	114.2	105.8	298.7	1.25	1.000	12.0
5	78.64	142.8	97.0	318.4	1.17	1.000	12.0
6	78.64	171.3	88.2	338.2	1.10	1.000	12.0
7	78.64	199.9	79.4	357.9	1.04	1.000	12.0
8	78.64	228.4	70.5	377.6	0.99	0.750	9.0
9	78.64	257.0	61.7	397.4	0.94	0.750	9.0
10	78.64	285.6	52.9	417.1	0.89	0.750	9.0
11	78.64	314.1	44.1	436.8	0.85	0.750	9.0
12	78.64	342.7	35.3	456.6	0.82	0.750	9.0

Layer No.	Depth z (ft)	Spacing Sv (ft)	Nonresisting	Resisting Length		Total Embedment		Overlap Length		Cut
			Length Lr (ft)	Le (calc) (ft)	Le (min) (ft)	Lt (calc) (ft)	Lt (use) (ft)	Lo (calc) (ft)	Lo (use) (ft)	Length Lc (ft)
13	1.50	1.50	5.35	5.48	5.48	10.83	11.00	2.74	3.00	15.50
12	2.50	1.00	4.84	2.25	3.00	7.84	11.00	1.12	3.00	15.00
11	3.50	1.00	4.33	1.64	3.00	7.33	11.00	0.82	3.00	15.00
10	4.50	1.00	3.82	1.31	3.00	6.82	11.00	0.65	3.00	15.00
9	5.50	1.00	3.31	1.10	3.00	6.31	11.00	0.55	3.00	15.00
8	6.50	1.00	2.80	0.95	3.00	5.80	6.00	0.47	3.00	10.00
7	7.50	1.00	2.29	0.84	3.00	5.29	6.00	0.42	3.00	10.00
6	8.25	0.75	1.91	0.58	3.00	4.91	6.00	0.29	3.00	9.75
5	9.00	0.75	1.53	0.54	3.00	4.53	6.00	0.27	3.00	9.75
4	9.75	0.75	1.15	0.51	3.00	4.15	6.00	0.25	3.00	9.75
3	10.50	0.75	0.76	0.48	3.00	3.76	6.00	0.24	3.00	9.75
2	11.25	0.75	0.38	0.46	3.00	3.38	6.00	0.23	3.00	9.75
1	12.00	0.75	0.00	0.43	3.00	3.00	6.00	0.22	3.00	9.75

Overturning

$$P_{ac} = 4057.8$$

$$\textcircled{a} \quad h = 5.30'$$

$$P_{ac} \sin \phi = 2385.1$$

$$P_{ac} \cos \phi = 3282.8$$

$$F_{sot} = \frac{5.5(11)(110)(5.5) + 6.5(6)(110)(3) + 2385.1(6)}{3282.8(5.3)} = 3.67 \text{ OK!}$$

Sliding

$$F_{sl} = \left( \frac{320 + \frac{5.5(110)11 + 6.5(110)6 + 2385.1 + 24}{6}}{3282.8} \right) 6 = 2.39$$

NO good

increase bottom layers to 10'

$$F_{sl} = 3.17 \text{ OK}$$

Layer No.	Depth z (ft)	Spacing Sv (ft)	Embedment Length Lt (ft)	Overlap Length Lo (ft)	Cut Length Lc (ft)
13	1.50	1.50	11	3	15.50
12	2.50	1.00	11	3	15.00
11	3.50	1.00	11	3	15.00
10	4.50	1.00	11	3	15.00
9	5.50	1.00	11	3	15.00
8	6.50	1.00	10	3	14.00
7	7.50	1.00	10	3	14.00
6	8.25	0.75	10	3	13.75
5	9.00	0.75	10	3	13.75
4	9.75	0.75	10	3	13.75
3	10.50	0.75	10	3	13.75
2	11.25	0.75	10	3	13.75
1	12.00	0.75	10	3	13.75
<b>Total Fabric Length per Linear foot of wall (ft/ft)</b>					<b>186.00</b>

# Extended Koerner method

(A)

$$k_H = 0.1$$

$$L_c = (H - z) \sqrt{45 - \rho/z}$$

Depth z (ft)	Sigma q (lb/ft <sup>2</sup> )	Sigma s (lb/ft <sup>2</sup> )	Delta Sigma dyn (lb/ft <sup>2</sup> )	SIGMA d (lb/ft <sup>2</sup> )	Sv (ft)	Sv Use (ft)	Sv Use (inch)
0	63.20	0.0	59.6	122.8	3.04	2.000	24.0
1	63.20	28.6	55.8	147.6	2.53	2.000	24.0
2	63.20	57.1	52.1	172.4	2.16	2.000	24.0
3	63.20	85.7	48.4	197.3	1.89	1.500	18.0
4	63.20	114.2	44.7	222.1	1.68	1.500	18.0
5	63.20	142.8	40.9	246.9	1.51	1.500	18.0
6	63.20	171.3	37.2	271.8	1.37	1.000	12.0
7	63.20	199.9	33.5	296.6	1.26	1.000	12.0
8	63.20	228.4	29.8	321.4	1.16	1.000	12.0
9	63.20	257.0	26.1	346.3	1.08	1.000	12.0
10	63.20	285.6	22.3	371.1	1.01	1.000	12.0
11	63.20	314.1	18.6	395.9	0.94	0.750	9.0
12	63.20	342.7	14.9	420.8	0.89	0.750	9.0

Layer No.	Depth z (ft)	Spacing Sv (ft)	Nonresisting Length	Resisting Length		Total Embedment Length		Overlap Length		Cut Length
			Lr (ft)	Le (calc) (ft)	Le (min) (ft)	Lt (calc) (ft)	Lt (use) (ft)	Lo (calc) (ft)	Lo (use) (ft)	Lc (ft)
11	2.00	2.00	5.10	5.54	5.54	10.64	11.00	2.77	3.00	16.00
10	3.50	1.50	4.33	2.47	3.00	7.33	11.00	1.23	3.00	15.50
9	5.00	1.50	3.57	1.79	3.00	6.57	11.00	0.89	3.00	15.50
8	6.00	1.00	3.06	1.02	3.00	6.06	11.00	0.51	3.00	15.00
7	7.00	1.00	2.55	0.89	3.00	5.55	11.00	0.45	3.00	15.00
6	8.00	1.00	2.04	0.80	3.00	5.04	5.00	0.40	3.00	9.00
5	9.00	1.00	1.53	0.72	3.00	4.53	5.00	0.36	3.00	9.00
4	9.75	0.75	1.15	0.51	3.00	4.15	5.00	0.25	3.00	8.75
3	10.50	0.75	0.76	0.48	3.00	3.76	5.00	0.24	3.00	8.75
2	11.25	0.75	0.38	0.46	3.00	3.38	5.00	0.23	3.00	8.75
1	12.00	0.75	0.00	0.43	3.00	3.00	5.00	0.22	3.00	8.75

Overturning

$$P_{ae} = 3261.6$$

$$\textcircled{a} \quad h = 4.90'$$

$$P_{ae} \sin \phi = 1917.1$$

$$P_{ae} \cos \phi = 2638.7$$

$$FSOT = \frac{7(11)(110)5.5 + 5(5)(110)(2.5) + 1917.1(5)}{2638.7(4.9)} = 4.87 > 3 \quad \text{OK}$$

Sliding

$$FS_{sl} = \left( \frac{320 + \frac{7(11)110 + 5(5)110 + 19(7.1) \tan 24}{5}}{2638.7} \right) 5 = 2.82 \text{ NO good}$$

increase bottom layers to 6'

$$FS_{sl} = 3.04 \quad \text{OK!}$$

Layer No.	Depth z (ft)	Spacing Sv (ft)	Embedment Length Lt (ft)	Overlap Length Lo (ft)	Cut Length Lc (ft)
11	2.00	2.00	11	3	16.00
10	3.50	1.50	11	3	15.50
9	5.00	1.50	11	3	15.50
8	6.00	1.00	11	3	15.00
7	7.00	1.00	11	3	15.00
6	8.00	1.00	6	3	10.00
5	9.00	1.00	6	3	10.00
4	9.75	0.75	6	3	9.75
3	10.50	0.75	6	3	9.75
2	11.25	0.75	6	3	9.75
1	12.00	0.75	6	3	9.75
<b>Total Fabric Length per Linear foot of wall (ft/ft)</b>					<b>136.00</b>

## APPENDIX B

method **(B)**

modified

~~Standard~~ Koerner method

$$k_n = 0.5$$

$$PBA = 16.1 \text{ ft/sec}^2$$

$$k_n = 0.5$$

$$P = 33.9^\circ$$

$$K_{ac} = \frac{(35-36)(0.716 - 0.596)}{35-40} + 0.716 = 0.6920$$

$$\Delta K_{dyn} = K_{ac} - k_a = 0.6920 - 0.2596 = 0.4324$$

$$\begin{aligned} \sigma_d &= 0.6920(200) + 0.2596(110)z + 0.4324(110) [0.8(12) - 0.6z] \\ &= 138.4 + 28.6z + 47.6 [9.6 - 0.6z] \end{aligned}$$

$$S_v = \frac{484.75}{1.3 [138.4 + 28.6z + 47.6(9.6 - 0.6z)]}$$

Depth z (ft)	Sigma q (lb/ft <sup>2</sup> )	Sigma s (lb/ft <sup>2</sup> )	Delta Sigma dyn (lb/ft <sup>2</sup> )	SIGMA d (lb/ft <sup>2</sup> )	Sv (ft)	Sv Use (ft)	Sv Use (inch)
0	138.40	0.0	456.6	595.0	0.63	0.580	7.0
1	138.40	28.6	428.1	595.0	0.63	0.580	7.0
2	138.40	57.1	399.5	595.0	0.63	0.580	7.0
3	138.40	85.7	371.0	595.1	0.63	0.580	7.0
4	138.40	114.2	342.5	595.1	0.63	0.580	7.0
5	138.40	142.8	313.9	595.1	0.63	0.580	7.0
6	138.40	171.3	285.4	595.1	0.63	0.580	7.0
7	138.40	199.9	256.8	595.1	0.63	0.580	7.0
8	138.40	228.4	228.3	595.2	0.63	0.580	7.0
9	138.40	257.0	199.8	595.2	0.63	0.580	7.0
10	138.40	285.6	171.2	595.2	0.63	0.580	7.0
11	138.40	314.1	142.7	595.2	0.63	0.580	7.0
12	138.40	342.7	114.2	595.2	0.63	0.580	7.0



# Fabric Length

$$L_r = (H-z) \tan(90-\theta) = 1.488(12-z)$$

$$L_e = \frac{S_v [138.4 + 28.6z + 47.6(9.6 - 0.6z)]}{2(110)z \tan 24} \cdot 1.3$$

$$L_t = L_r + L_e \quad L_o = \frac{1}{2} L_e \geq 3'$$

$$L_c = L_t + L_o + S_v$$

Layer No.	Depth z (ft)	Spacing Sv (ft)	Nonresisting Length	Resisting Length		Total Embedment Length		Overlap Length		Cut Length
			Lr (ft)	Le (calc) (ft)	Le (min) (ft)	Lt (calc) (ft)	Lt (use) (ft)	Lo (calc) (ft)	Lo (use) (ft)	Lc (ft)
21	0.58	0.58	16.99	5.35	5.35	22.34	23.00	2.67	3.00	26.58
20	1.16	0.58	16.13	2.71	3.00	19.13	23.00	1.36	3.00	26.58
19	1.74	0.58	15.27	1.84	3.00	18.27	23.00	0.92	3.00	26.58
18	2.32	0.58	14.41	1.40	3.00	17.41	18.00	0.70	3.00	21.58
17	2.90	0.58	13.54	1.13	3.00	16.54	18.00	0.57	3.00	21.58
16	3.48	0.58	12.68	0.96	3.00	15.68	18.00	0.48	3.00	21.58
15	4.06	0.58	11.82	0.83	3.00	14.82	18.00	0.42	3.00	21.58
14	4.64	0.58	10.95	0.74	3.00	13.95	18.00	0.37	3.00	21.58
13	5.22	0.58	10.09	0.67	3.00	13.09	18.00	0.33	3.00	21.58
12	5.80	0.58	9.23	0.61	3.00	12.23	18.00	0.30	3.00	21.58
11	6.38	0.58	8.36	0.56	3.00	11.36	18.00	0.28	3.00	21.58
10	6.96	0.58	7.50	0.52	3.00	10.50	18.00	0.26	3.00	21.58
9	7.54	0.58	6.64	0.49	3.00	9.64	10.00	0.24	3.00	13.58
8	8.12	0.58	5.77	0.46	3.00	8.77	10.00	0.23	3.00	13.58
7	8.70	0.58	4.91	0.43	3.00	7.91	10.00	0.22	3.00	13.58
6	9.28	0.58	4.05	0.41	3.00	7.05	10.00	0.20	3.00	13.58
5	9.86	0.58	3.18	0.39	3.00	6.18	10.00	0.20	3.00	13.58
4	10.44	0.58	2.32	0.37	3.00	5.32	10.00	0.19	3.00	13.58
3	11.02	0.58	1.46	0.36	3.00	4.46	10.00	0.18	3.00	13.58
2	11.60	0.58	0.60	0.34	3.00	3.60	10.00	0.17	3.00	13.58
1	12.00	0.40	0.00	0.23	3.00	3.00	10.00	0.12	3.00	13.40

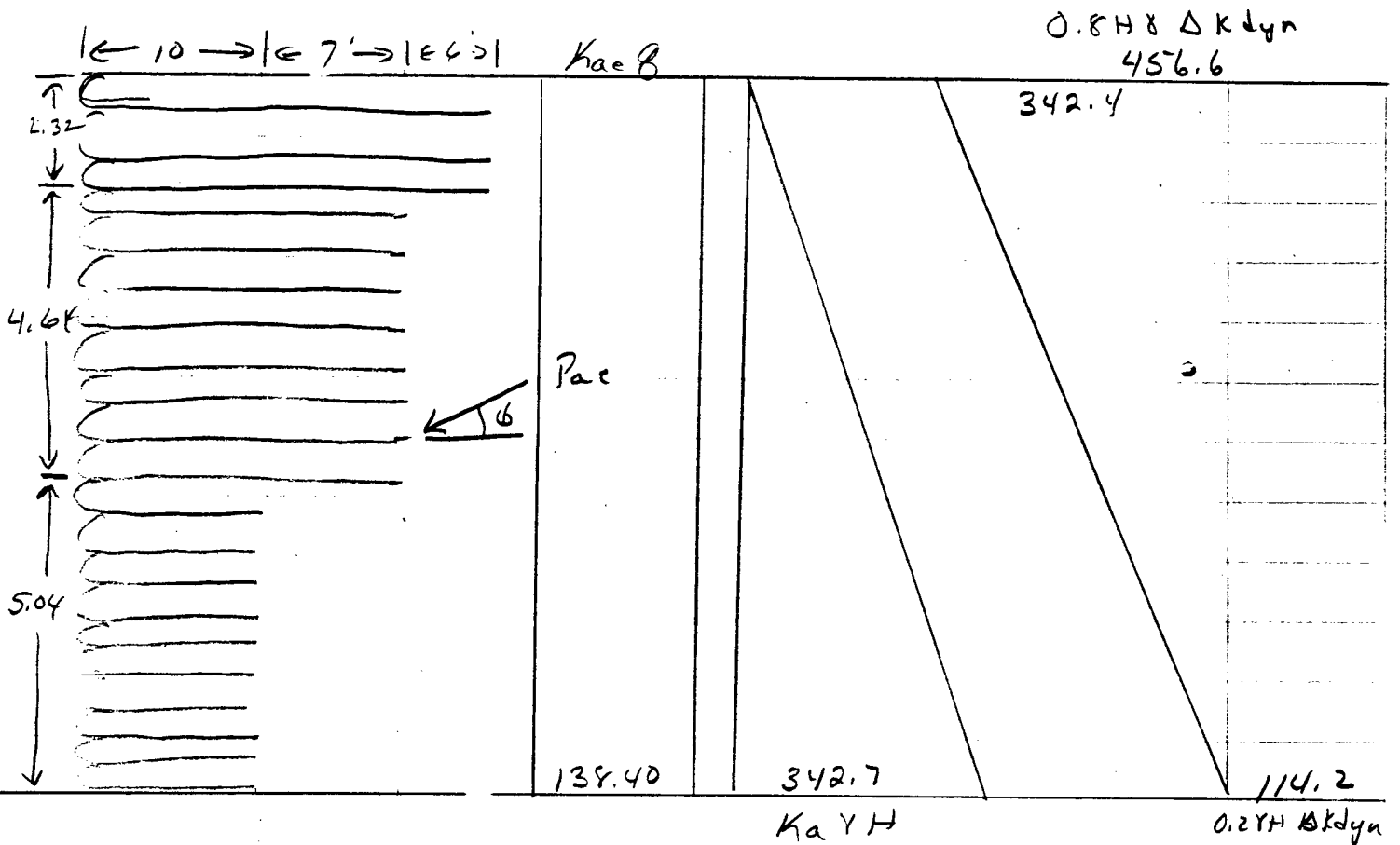

$$P_a = 138.4(12) = 1660.8$$

$$P_a = \frac{1}{2}(342.7)(12) = 2056.2$$

$$P_{dyn1} = \frac{1}{2}(342.4)(12) = 2054.4$$

$$P_{dyn2} = 114.2(12) = 1370.4$$

$$P_{ae} = 7141.8$$

$$\textcircled{a} \quad \frac{1}{2}H = 6$$

$$\textcircled{a} \quad \frac{1}{3}H = 4$$

$$\textcircled{a} \quad \frac{2}{3}H = 8$$

$$\textcircled{a} \quad \frac{1}{2}H = 6$$

$$\textcircled{a} \quad h = 6.0$$

$$P_{ae} \sin \phi = 4197.8$$

$$P_{ae} \cos \phi = 5777.8$$

$$FSOT = \frac{W_1 \gamma_1 + W_2 \gamma_2 + W_3 \gamma_3 + P_{ae} \sin \phi (18)}{P_{ae} \cos \phi (h)}$$

$$= \frac{5.04(10)(110)(5) + 4.69(17)(110)(8.5) + 2.32(23)(110)(11.5) + 4197.8(18)}{5777.8(6.0)}$$

$$= 5.57 > 3 \quad OK$$

Sliding

$$FS_s = \frac{320 + \frac{5.04(19)_{110} + 4.04(17)_{110} + 2.32(23)_{110} + 4197.8}{10} \tan 24}{5777.8}$$

= 2.08 No good!

increase bottom layers to 17'

$$FS_s = 3.11 > 3 \text{ OK!}$$

Layer No.	Depth z (ft)	Spacing Sv (ft)	Embedment Overlap		Cut Length Lc (ft)
			Length Lt (ft)	Length Lo (ft)	
21	0.58	0.58	23.00	3	26.58
20	1.16	0.58	23.00	3	26.58
19	1.74	0.58	23.00	3	26.58
18	2.32	0.58	17.00	3	20.58
17	2.90	0.58	17.00	3	20.58
16	3.48	0.58	17.00	3	20.58
15	4.06	0.58	17.00	3	20.58
14	4.64	0.58	17.00	3	20.58
13	5.22	0.58	17.00	3	20.58
12	5.80	0.58	17.00	3	20.58
11	6.38	0.58	17.00	3	20.58
10	6.96	0.58	17.00	3	20.58
9	7.54	0.58	17.00	3	20.58
8	8.12	0.58	17.00	3	20.58
7	8.70	0.58	17.00	3	20.58
6	9.28	0.58	17.00	3	20.58
5	9.86	0.58	17.00	3	20.58
4	10.44	0.58	17.00	3	20.58
3	11.02	0.58	17.00	3	20.58
2	11.60	0.58	17.00	3	20.58
1	12.00	0.58	17.00	3	20.58
Total Fabric Length per Linear foot of wall (ft/ft)					450.18

(B)

modified

Extension of Koerner method to a dynamic case

$PGA = 12.88 \text{ ft/sec}^2 \quad k_H = 0.4 \quad \rho = 40.7^\circ$

$K_{AE} = \frac{(35-40)(0.581-0.488)}{35-40} + 0.581 = 0.5345 \text{ (DAS p. 335)}$

$K_{dyn} = K_{AE} - k_a = 0.5345 - 0.2596 = 0.2749$

$\sigma_d = \sigma_g + \sigma_s + \Delta \sigma_{dyn} = K_{AE} z + k_a \delta z + \Delta K_{dyn} (0.8H - 0.6z) \delta$   
 $= 0.5345(200) + 0.2596(110)z + 0.2749(110)(0.8(12) - 0.6z)$   
 $= 106.9 + 28.6z + 30.2(9.6 - 0.6z)$

$T_{allow} = 484.85 \text{ lbs/ft}$

$S_v = \frac{T_{allow}}{FS \sigma_d} = \frac{484.85}{1.3 [106.9 + 28.6z + 30.2(9.6 - 0.6z)]}$

Depth z (ft)	Sigma q (lb/ft <sup>2</sup> )	Sigma s (lb/ft <sup>2</sup> )	Delta Sigma dyn (lb/ft <sup>2</sup> )	SIGMA d (lb/ft <sup>2</sup> )	Sv Sv (ft)	Sv Use (ft)	Sv Use (inch)
0	106.90	0.0	290.3	397.2	0.94	0.667	8.0
1	106.90	28.6	272.2	407.6	0.91	0.667	8.0
2	106.90	57.1	254.0	418.0	0.89	0.667	8.0
3	106.90	85.7	235.9	428.4	0.87	0.667	8.0
4	106.90	114.2	217.7	438.8	0.85	0.667	8.0
5	106.90	142.8	199.6	449.3	0.83	0.667	8.0
6	106.90	171.3	181.4	459.7	0.81	0.667	8.0
7	106.90	199.9	163.3	470.1	0.79	0.667	8.0
8	106.90	228.4	145.1	480.5	0.78	0.667	8.0
9	106.90	257.0	127.0	490.9	0.76	0.667	8.0
10	106.90	285.6	108.9	501.3	0.74	0.667	8.0
11	106.90	314.1	90.7	511.7	0.73	0.667	8.0
12	106.90	342.7	72.6	522.1	0.71	0.667	8.0

### Fabric Length

$$L_r = (H-z) \tan(90-\beta) = (12-z) \tan(90-40.7) = (12-z) 1.1626$$

$$L_e = \frac{S_v \sum d F S}{z(c + \gamma z \tan \phi)} = \frac{S_v [106.9 + 28.6z + 30.2(9.6 - 0.6z)] 1.3}{z(110) z \tan 24}$$

$$L_t = L_r + L_e$$

$$L_o = \frac{1}{2} L_e \geq 3' = \frac{S_v [106.9 + 28.6z + 30.2(9.6 - 0.6z)] 1.3}{4(110) z \tan 24}$$

$$L_c = L_t + L_o + S_v$$

Layer No.	Depth z (ft)	Spacing Sv (ft)	Nonresisting Length	Resisting Length		Total Embedment Length		Overlap Length		Cut Length
			Lr (ft)	Le (calc) (ft)	Le (min) (ft)	Lt (calc) (ft)	Lt (use) (ft)	Lo (calc) (ft)	Lo (use) (ft)	Lc (ft)
18	0.67	0.67	13.17	5.38	5.36	18.53	19.00	2.68	3.00	22.67
17	1.34	0.67	12.39	2.73	3.00	15.39	19.00	1.36	3.00	22.67
16	2.01	0.67	11.61	1.85	3.00	14.61	19.00	0.92	3.00	22.67
15	2.68	0.67	10.84	1.41	3.00	13.84	19.00	0.70	3.00	22.67
14	3.35	0.67	10.06	1.15	3.00	13.06	19.00	0.57	3.00	22.67
13	4.02	0.67	9.28	0.97	3.00	12.28	19.00	0.49	3.00	22.67
12	4.69	0.67	8.50	0.85	3.00	11.50	19.00	0.42	3.00	22.67
11	5.36	0.67	7.72	0.75	3.00	10.72	19.00	0.38	3.00	22.67
10	6.03	0.67	6.94	0.68	3.00	9.94	10.00	0.34	3.00	13.67
9	6.70	0.67	6.16	0.62	3.00	9.16	10.00	0.31	3.00	13.67
8	7.37	0.67	5.38	0.57	3.00	8.38	10.00	0.29	3.00	13.67
7	8.04	0.67	4.60	0.53	3.00	7.60	10.00	0.27	3.00	13.67
6	8.71	0.67	3.82	0.50	3.00	6.82	10.00	0.25	3.00	13.67
5	9.38	0.67	3.05	0.47	3.00	6.05	10.00	0.23	3.00	13.67
4	10.05	0.67	2.27	0.44	3.00	5.27	10.00	0.22	3.00	13.67
3	10.72	0.67	1.49	0.42	3.00	4.49	10.00	0.21	3.00	13.67
2	11.39	0.67	0.71	0.40	3.00	3.71	10.00	0.20	3.00	13.67
1	12.00	0.67	0.00	0.39	3.00	3.00	10.00	0.19	3.00	13.67

# External Stability

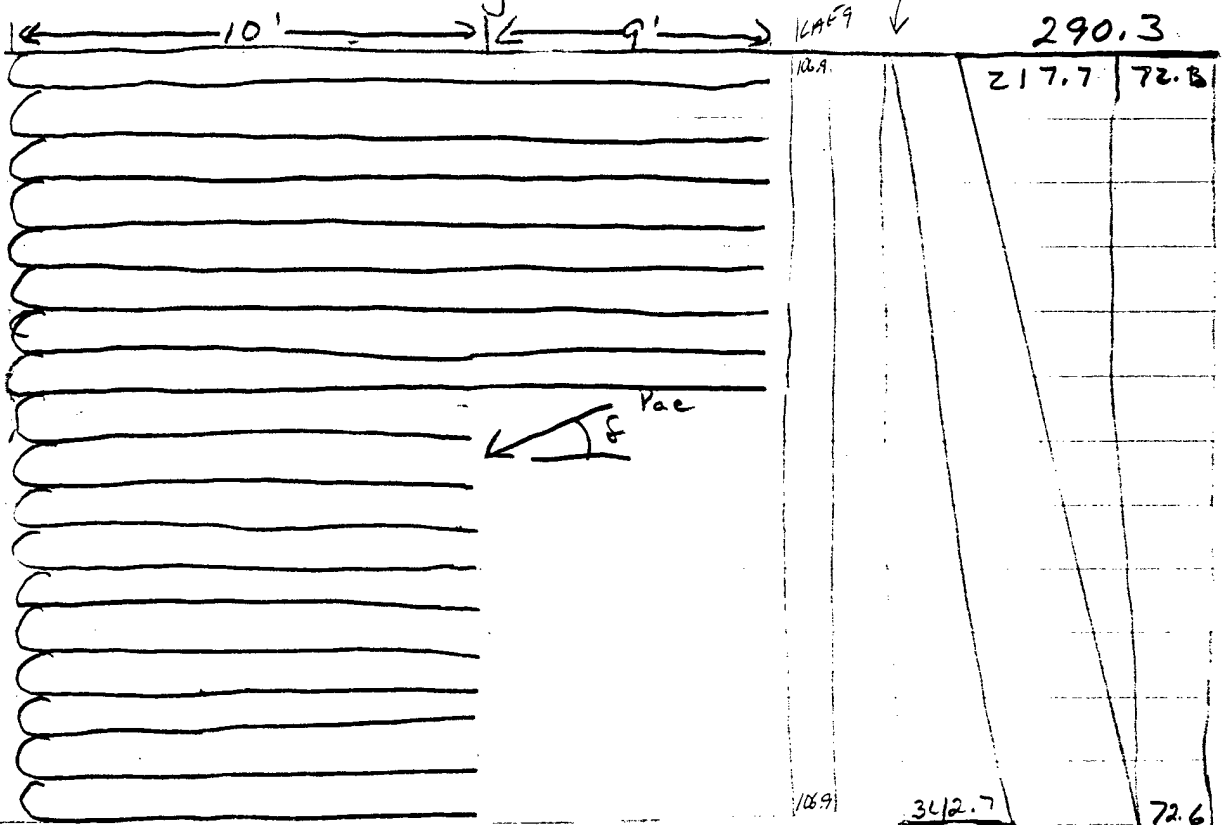

$$P_a = \frac{1}{2} \gamma H^2 K_a = \frac{1}{2} (110) (10^2) (0.2596) = 2056 \text{ lb/ft} \quad @ \quad \frac{1}{2} H = 5'$$

$$P_{dyn1} = \frac{1}{2} (12) (217.7) = 1306.2 \quad @ \quad \frac{2}{3} H = 8'$$

$$P_{dyn2} = 72.6 (12) = 871.2 \quad @ \quad \frac{1}{2} H = 6'$$

$$P_s = 106.9 (12) = 1282.8 \quad @ \quad \frac{1}{2} H = 6'$$

$$P = P_s + P_a + P_{dyn1} + P_{dyn2} = 1282.8 + 2056 + 1306.2 + 871.2 = 5516.2 \text{ lbs/ft}$$

$$F = \frac{2056(4) + 1282.8(6) + 1306.2(8) + 871.2(6)}{5516.2} = 5.73'$$

$$P_{AE} \cos \phi = 5516.2 \cos 36 = 4462.7 \text{ lbs/ft}$$

$$P_{AE} \sin \phi = 5516.2 \sin 36 = 3242.3 \text{ lbs/ft}$$

### Overturning

$$FS_{OT} = \frac{\sum \text{Resisting moments}}{\sum \text{Driving moments}}$$

$$= \frac{W_1 V_1 + W_2 V_2 + Pae \sin \phi (10)}{Pae \cos \phi (h)}$$

$$= \frac{19(5.36)110\left(\frac{19}{2}\right) + 10(6.64)\left(\frac{10}{2}\right)110 + 3242.3(10)}{4462.7(5.73)}$$

$$= 6.32 > 3 \quad \text{O.K.}$$

### Sliding

$$FS_s = \frac{C_a + \left( \frac{W + Pae \sin \phi}{L} \tan \delta \right) L}{Pae \cos \phi}$$

$$= \frac{320 + \left( \frac{[19(5.36) + 10(6.64)]110 + 3242.3}{10} \tan 24 \right) 10}{4462.7}$$

$$= 2.87 < 3 \quad \text{NO GOOD}$$

increase bottom layers to 11

$$FS_s = \frac{320 + \left( \frac{[19(5.36) + 11(6.64)]110 + 3242.3}{11} \tan 24 \right) 11}{4462.7}$$

$$= 3.03 \quad \text{OK}$$

Layer No.	Depth z (ft)	Spacing Sv (ft)	Embedment Length Lt (ft)	Overlap Length Lo (ft)	Cut Length Lc (ft)
18	0.67	0.67	19	3	22.67
17	1.34	0.67	19	3	22.67
16	2.01	0.67	19	3	22.67
15	2.68	0.67	19	3	22.67
14	3.35	0.67	19	3	22.67
13	4.02	0.67	19	3	22.67
12	4.69	0.67	19	3	22.67
11	5.36	0.67	19	3	22.67
10	6.03	0.67	11	3	14.67
9	6.70	0.67	11	3	14.67
8	7.37	0.67	11	3	14.67
7	8.04	0.67	11	3	14.67
6	8.71	0.67	11	3	14.67
5	9.38	0.67	11	3	14.67
4	10.05	0.67	11	3	14.67
3	10.72	0.67	11	3	14.67
2	11.39	0.67	11	3	14.67
1	12.00	0.67	11	3	14.67
<b>Total Fabric Length per Linear foot of wall (ft)</b>					<b>328.06</b>



(B)

modified

~~Hoerner~~ method Extension  $k_h = 0.3$

$P_{GA} = 9.66 \text{ ft/sec}^2$   $k_h = 0.3$   $\beta = 47.2^\circ$

$K_{ae} = 0.4624$

$\Delta K_{dyn} = K_{ae} - K_a = 0.4624 - 0.2596 = 0.2028$

$\Delta d = 92.5 + 28.6z + 22.3(9.6 - 0.6z)$

$\epsilon_v = \frac{48485}{1.3 [92.5 + 28.6 + 22.3(9.6 - 0.6z)]}$

Depth z (ft)	Sigma q (lb/ft^2)	Sigma s (lb/ft^2)	Delta Sigma dyn (lb/ft^2)	SIGMA d (lb/ft^2)	Sv (ft)	Sv Use (ft)	Sv Use (inch)
0	92.48	0.0	214.2	306.6	1.22	1.000	<del>8.0</del> 12
1	92.48	28.6	200.8	321.8	1.16	1.000	<del>8.0</del> 12
2	92.48	57.1	187.4	337.0	1.11	1.000	<del>8.0</del> 12
3	92.48	85.7	174.0	352.2	1.06	1.000	<del>8.0</del> 12
4	92.48	114.2	160.6	367.3	1.02	1.000	<del>8.0</del> 12
5	92.48	142.8	147.2	382.5	0.98	0.750	<del>8.0</del> 9
6	92.48	171.3	133.8	397.7	0.94	0.750	<del>8.0</del> 9
7	92.48	199.9	120.5	412.8	0.90	0.750	<del>8.0</del> 9
8	92.48	228.4	107.1	428.0	0.87	0.750	<del>8.0</del> 9
9	92.48	257.0	93.7	443.2	0.84	0.750	<del>8.0</del> 9
10	92.48	285.6	80.3	458.3	0.81	0.750	<del>8.0</del> 9
11	92.48	314.1	66.9	473.5	0.79	0.750	<del>8.0</del> 9
12	92.48	342.7	53.5	488.7	0.76	0.750	<del>8.0</del> 9

## Fabric Length

$$L_R = (2-z) \cdot 0.9260$$

$$L_e = S_v(1.3) \left[ 92.5 + 28.6z + 22.3(9.6 - 0.6z) \right] \\ 2(110)z \tan 24$$

$$L_t = L_R + L_e \quad L_o = \frac{1}{2} L_e \geq 3'$$

$$L_c = L_t + L_o + S_v$$

Layer No.	Depth z (ft)	Spacing Sv (ft)	Nonresisting	Resisting Length		Total Embedment		Overlap Length		Cut
			Length Lr (ft)	Le (calc) (ft)	Le (min) (ft)	Lt (calc) (ft)	Lt (use) (ft)	Lo (calc) (ft)	Lo (use) (ft)	Length Lc (ft)
15	1.00	1.00	10.19	5.41	5.41	15.59	16.00	2.70	3.00	20.00
14	2.00	1.00	9.26	2.77	3.00	12.26	16.00	1.39	3.00	20.00
13	3.00	1.00	8.33	1.89	3.00	11.33	16.00	0.95	3.00	20.00
12	4.00	1.00	7.41	1.46	3.00	10.41	16.00	0.73	3.00	20.00
11	4.75	0.75	6.71	0.94	3.00	9.71	16.00	0.47	3.00	19.75
10	5.50	0.75	6.02	0.82	3.00	9.02	16.00	0.41	3.00	19.75
9	6.25	0.75	5.32	0.74	3.00	8.32	16.00	0.37	3.00	19.75
8	7.00	0.75	4.63	0.67	3.00	7.63	8.00	0.33	3.00	11.75
7	7.75	0.75	3.94	0.61	3.00	6.94	8.00	0.31	3.00	11.75
6	8.50	0.75	3.24	0.57	3.00	6.24	8.00	0.28	3.00	11.75
5	9.25	0.75	2.55	0.53	3.00	5.55	8.00	0.27	3.00	11.75
4	10.00	0.75	1.85	0.50	3.00	4.85	8.00	0.25	3.00	11.75
3	10.75	0.75	1.16	0.47	3.00	4.16	8.00	0.24	3.00	11.75
2	11.50	0.75	0.46	0.45	3.00	3.46	8.00	0.22	3.00	11.75
1	12.00	0.50	0.00	0.29	3.00	3.00	8.00	0.14	3.00	11.50

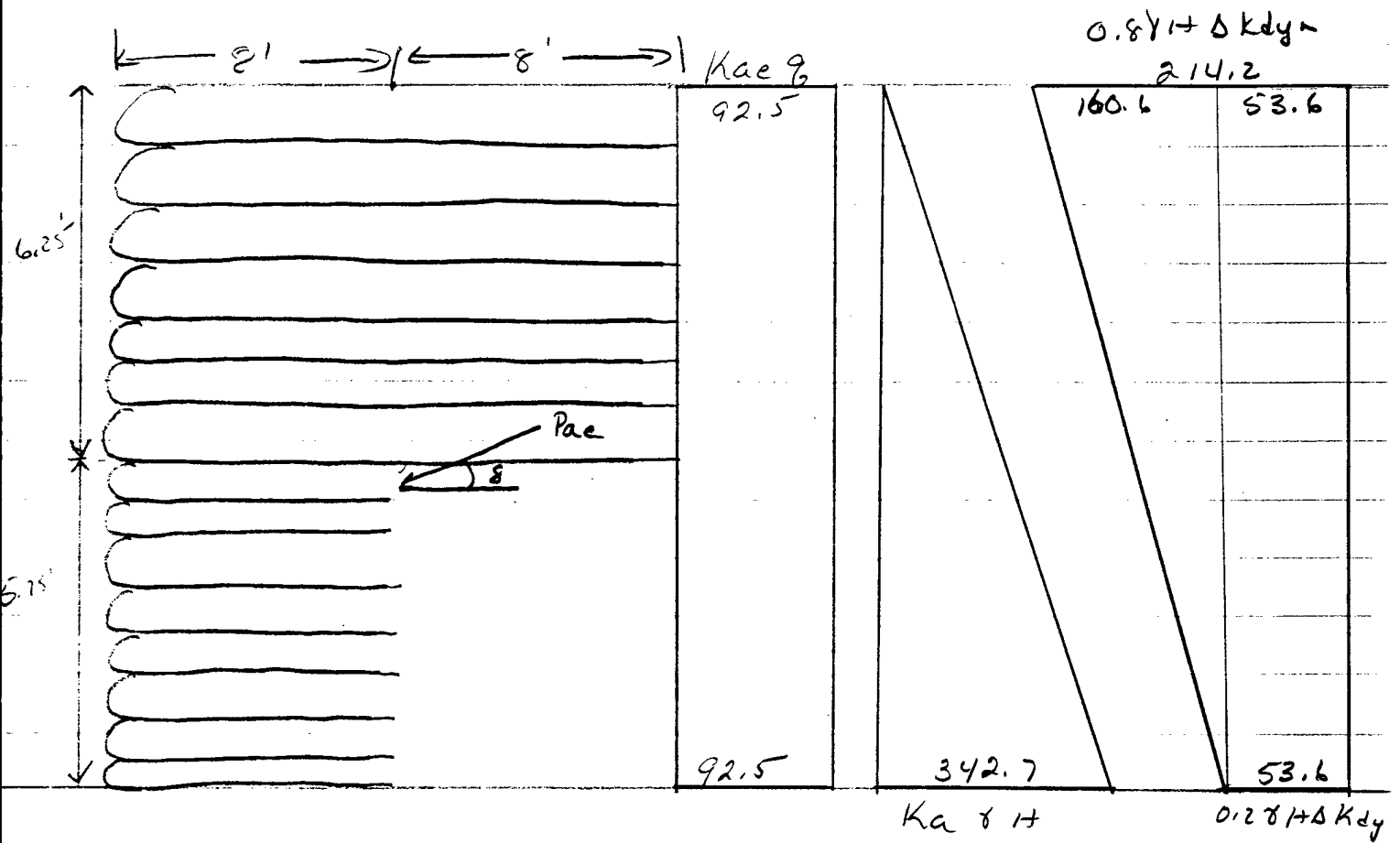

$$\begin{aligned}
 P_q &= 92.5(12) = 1110 \\
 P_a &= \frac{1}{2}(342.7)(12) = 2056.2 \\
 P_{dyn,1} &= \frac{1}{2}(160.6)(12) = 963.6 \\
 P_{dyn,2} &= 53.6(12) = \underline{643.2} \\
 &4773.0
 \end{aligned}$$

- (a)  $\frac{1}{2}H = 6$
- (a)  $\frac{1}{3}H = 4$
- (a)  $\frac{2}{3}H = 8$
- (a)  $\frac{1}{2}H = \underline{6}$
- (a)  $n = 5.54'$

$$P_a \sin \phi = 2805.5 \qquad P_a \cos \phi = 3861.4$$

$$\begin{aligned}
 F_{SOR} &= \frac{w_1 x_1 + w_2 x_2 + P_a \sin \phi (8')}{P_a \cos \phi (h)} \\
 &= \frac{6.25(16) + 110(8) + 5.75(8)(110)(4) + 2805.5(8)}{3861.4(5.54)} = 6.11 > 3 \quad \text{OK}
 \end{aligned}$$

Sliding

$$FS_s = \frac{(C_a + \frac{W + P_{ae} \sin \phi}{L} \tan 2\psi)}{P_{ae} \cos \phi} L$$

$$= \frac{(320 + \frac{6.25(16)110 + 5.75(8)110 + 2805.5}{8} \tan 24)}{3861.4} 8 = 2.83 < 3$$

NO good

move bottom layers to 10'

$$FS_s = \frac{320 + (\frac{6.25(16)(110) + 5.75(10)(110) + 2805.5}{10}) \tan 24}{3861.4} 10 = 3.15 > 1$$

Final!

Layer No.	Depth z (ft)	Spacing Sv (ft)	Embedment Length Lt (ft)	Overlap Length Lo (ft)	Cut Length Lc (ft)
15	1.00	1.00	16	3	20.00
14	2.00	1.00	16	3	20.00
13	3.00	1.00	16	3	20.00
12	4.00	1.00	16	3	20.00
11	4.75	0.75	16	3	19.75
10	5.50	0.75	16	3	19.75
9	6.25	0.75	16	3	19.75
8	7.00	0.75	10	3	13.75
7	7.75	0.75	10	3	13.75
6	8.50	0.75	10	3	13.75
5	9.25	0.75	10	3	13.75
4	10.00	0.75	10	3	13.75
3	10.75	0.75	10	3	13.75
2	11.50	0.75	10	3	13.75
1	12.00	0.50	10	3	13.50
<b>Total Fabric Length per Linear foot of wall (ft/ft)</b>					<b>249.00</b>

(B)

modified  
~~extended~~ Koerner method

$$k_r = 0.2$$

$$PGA = 6.44 \text{ ft/sec}^2 \quad k_r = 0.2$$

$$P = 52.8$$

$$K_{ae} = 0.3932$$

$$\Delta K_{dyn} = K_{ae} - K_a = 0.3932 - 0.2596 = 0.1336$$

$$\Delta d = 78.6 + 28.6z + 14.7(9.6 - 0.6z)$$

$$S_v = \frac{484.85}{1.3 [78.6 + 28.6z + 14.7(9.6 - 0.6z)]}$$

Depth z (ft)	Sigma q (lb/ft <sup>2</sup> )	Sigma s (lb/ft <sup>2</sup> )	Delta Sigma dyn (lb/ft <sup>2</sup> )	SIGMA d (lb/ft <sup>2</sup> )	Sv Sv (ft)	Sv Use (ft)	Sv Use (inch)
0	78.64	0.0	141.1	219.7	1.70	1.500	18.0
1	78.64	28.6	132.3	239.5	1.56	1.500	18.0
2	78.64	57.1	123.4	259.2	1.44	1.000	12.0
3	78.64	85.7	114.6	278.9	1.34	1.000	12.0
4	78.64	114.2	105.8	298.7	1.25	1.000	12.0
5	78.64	142.8	97.0	318.4	1.17	1.000	12.0
6	78.64	171.3	88.2	338.2	1.10	1.000	12.0
7	78.64	199.9	79.4	357.9	1.04	1.000	12.0
8	78.64	228.4	70.5	377.6	0.99	0.750	9.0
9	78.64	257.0	61.7	397.4	0.94	0.750	9.0
10	78.64	285.6	52.9	417.1	0.89	0.750	9.0
11	78.64	314.1	44.1	436.8	0.85	0.750	9.0
12	78.64	342.7	35.3	456.6	0.82	0.750	9.0

## Fabric Length

$$L_R = (12 - z)(0.7590)$$

$$L_e = \frac{S_v(1.3) [78.6 + 28.6z + 14.7(9.6 - 0.6z)]}{2(110)z \tan 24}$$

$$L_t = L_e + L_R$$

$$L_o = \frac{1}{2} L_e \geq 3.0'$$

$$L_c = L_e + L_o + S_v$$

Layer No.	Depth z (ft)	Spacing S <sub>v</sub> (ft)	Nonresisting	Resisting Length		Total Embedment Length		Overlap Length		Cut
			Length L <sub>r</sub> (ft)	L <sub>e</sub> (calc) (ft)	L <sub>e</sub> (min) (ft)	L <sub>t</sub> (calc) (ft)	L <sub>t</sub> (use) (ft)	L <sub>o</sub> (calc) (ft)	L <sub>o</sub> (use) (ft)	L <sub>c</sub> (ft)
13	1.50	1.50	7.97	5.48	5.48	13.45	14.00	2.74	3.00	18.50
12	2.50	1.00	7.21	2.25	3.00	10.21	14.00	1.12	3.00	18.00
11	3.50	1.00	6.45	1.64	3.00	9.45	14.00	0.82	3.00	18.00
10	4.50	1.00	5.69	1.31	3.00	8.69	14.00	0.65	3.00	18.00
9	5.50	1.00	4.93	1.10	3.00	7.93	14.00	0.55	3.00	18.00
8	6.50	1.00	4.17	0.95	3.00	7.17	14.00	0.47	3.00	18.00
7	7.50	1.00	3.42	0.84	3.00	6.42	7.00	0.42	3.00	11.00
6	8.25	0.75	2.85	0.58	3.00	5.85	7.00	0.29	3.00	10.75
5	9.00	0.75	2.28	0.54	3.00	5.28	7.00	0.27	3.00	10.75
4	9.75	0.75	1.71	0.51	3.00	4.71	7.00	0.25	3.00	10.75
3	10.50	0.75	1.14	0.48	3.00	4.14	7.00	0.24	3.00	10.75
2	11.25	0.75	0.57	0.46	3.00	3.57	7.00	0.23	3.00	10.75
1	12.00	0.75	0.00	0.43	3.00	3.00	7.00	0.22	3.00	10.75

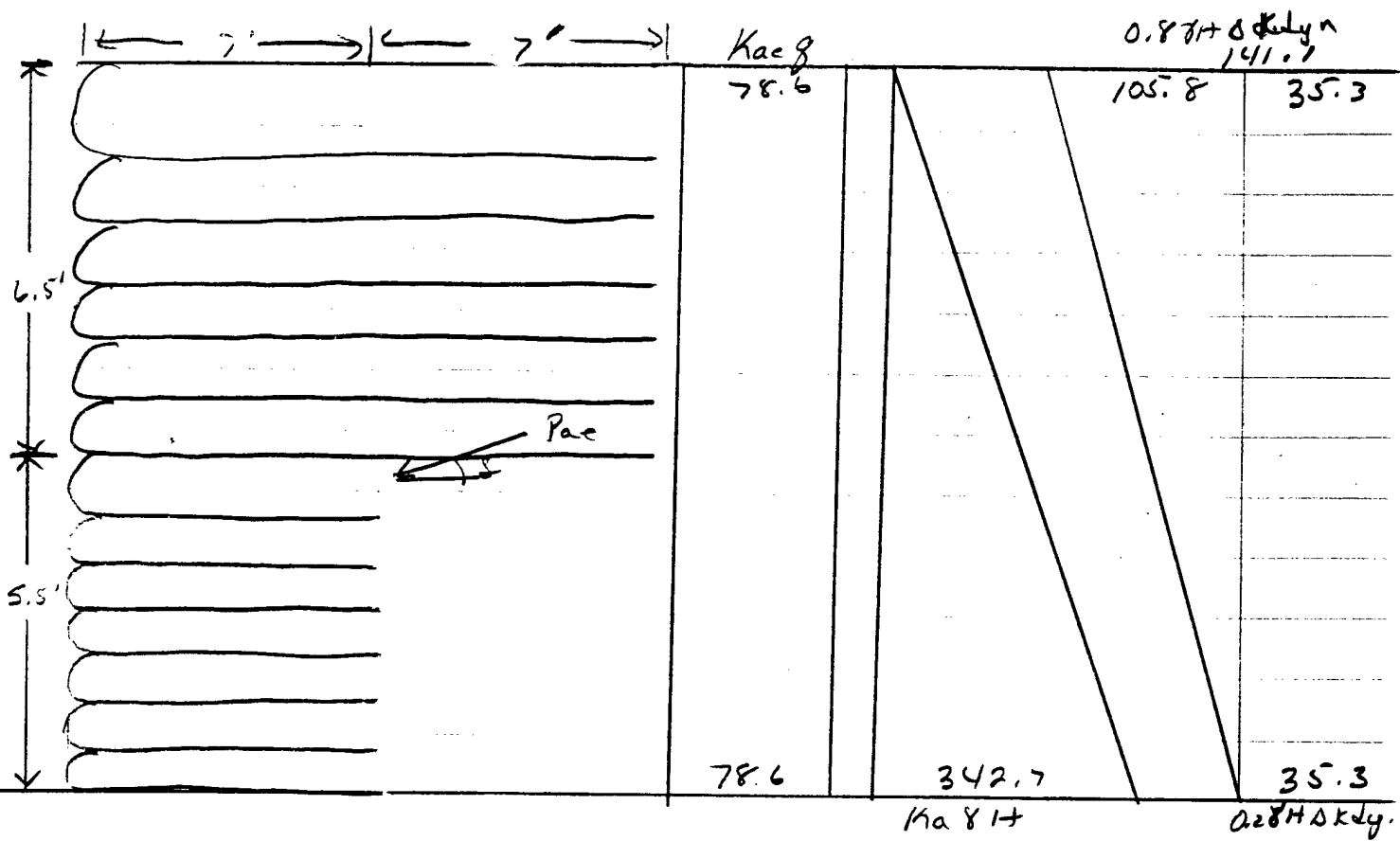

$$P_g = 78.6(12) = 943.2$$

$$P_a = \frac{1}{2}(342.7)(12) = 2056.2$$

$$P_{dyn_1} = \frac{1}{2}(105.8)(12) = 634.8$$

$$P_{dyn_2} = 35.3(12) = 423.6$$

$$P_{ae} = 4057.8$$

$$\textcircled{a} \quad \frac{1}{2}H = 6$$

$$\textcircled{a} \quad \frac{1}{3}H = 4$$

$$\textcircled{a} \quad \frac{2}{3}H = 8$$

$$\textcircled{a} \quad \frac{1}{2}H = 6$$

$$\textcircled{a} \quad h = 5.30$$

$$P_{ae} \sin \phi = 2385.1$$

$$P_{ae} \cos \phi = 3282.8$$

$$FSOT = \frac{6.5(14)(110)(7) + 5.5 \times 7(110)(3.5) + 2385.1(7)}{3282.8(5.30)} = 5.84 \text{ OK}$$

Sliding

$$F_{S_s} = \frac{320 + \frac{6.5(14)(110) + 5.5(7)(110) + 2385.1 \tan 24}{7}}{3282.8} = 2.946$$

no good!

Increase bottom layers to 8'

$$F_{S_s} = \frac{320 + \frac{6.5(14)(110) + 5.5(8)(110) + 2385.1 \tan 24}{8}}{3282.8} = 3.127$$

OK

Final: use 13 rows, top 6 to be 14' long  
bottom 7 to be 8' long  
Spaced as shown

Layer No.	Depth z (ft)	Spacing Sv (ft)	Embedment Overlap		Cut Length Lc (ft)
			Length Lt (ft)	Length Lo (ft)	
13	1.50	1.50	14	3	18.50
12	2.50	1.00	14	3	18.00
11	3.50	1.00	14	3	18.00
10	4.50	1.00	14	3	18.00
9	5.50	1.00	14	3	18.00
8	6.50	1.00	14	3	18.00
7	7.50	1.00	8	3	12.00
6	8.25	0.75	8	3	11.75
5	9.00	0.75	8	3	11.75
4	9.75	0.75	8	3	11.75
3	10.50	0.75	8	3	11.75
2	11.25	0.75	8	3	11.75
1	12.00	0.75	8	3	11.75
Total Fabric Length per Linear foot of wall (ft/ft)					191.00



(B)

modified

~~Hoerner~~ Extended method

$$\rho g A = 3.22 \text{ ft/sec}^2$$

$$K_p = 0.1$$

$$K_p = 0.1$$
  
$$f = 58.3^\circ$$

$$K_{ac} = 0.3160$$

$$K_a = 0.2596$$

$$\Delta K_{dyn} = 0.056 \gamma$$

$$\sigma_d = 63.2 + 28.6 z + 6.2(9.6 - 0.6 z)$$

$$S_v = \frac{484.85}{1.3 (63.2 + 28.6 z + 6.2(9.6 - 0.6 z))}$$

Depth z (ft)	Sigma q (lb/ft <sup>2</sup> )	Sigma s (lb/ft <sup>2</sup> )	Delta Sigma dyn (lb/ft <sup>2</sup> )	SIGMA d (lb/ft <sup>2</sup> )	Sv (ft)	Sv Use (ft)	Sv Use (inch)
0	63.20	0.0	59.6	122.8	3.04	2.000	24.0
1	63.20	28.6	55.8	147.6	2.53	2.000	24.0
2	63.20	57.1	52.1	172.4	2.16	2.000	24.0
3	63.20	85.7	48.4	197.3	1.89	1.500	18.0
4	63.20	114.2	44.7	222.1	1.68	1.500	18.0
5	63.20	142.8	40.9	246.9	1.51	1.500	18.0
6	63.20	171.3	37.2	271.8	1.37	1.000	12.0
7	63.20	199.9	33.5	296.6	1.26	1.000	12.0
8	63.20	228.4	29.8	321.4	1.16	1.000	12.0
9	63.20	257.0	26.1	346.3	1.08	1.000	12.0
10	63.20	285.6	22.3	371.1	1.01	1.000	12.0
11	63.20	314.1	18.6	395.9	0.94	0.750	9.0
12	63.20	342.7	14.9	420.8	0.89	0.750	9.0

Fabric Length

$$L_R = (12 - z) 0.6176$$

$$L_e = \frac{S_v(1.3) \left[ 63.2 + 28.6z + 6.2(9.6 - 0.6z) \right]}{2(110)(z) \tan 24}$$

$$L_t = L_e + L_R$$

$$L_o = \frac{1}{2} L_e \geq 3'$$

$$L_c = L_t + L_o + S_v$$

Layer No.	Depth z (ft)	Spacing Sv (ft)	Nonresisting	Resisting Length		Total Embedment Length		Overlap Length		Cut Length
			Lr (ft)	Le (calc) (ft)	Le (min) (ft)	Lt (calc) (ft)	Lt (use) (ft)	Lo (calc) (ft)	Lo (use) (ft)	Lc (ft)
11	2.00	2.00	6.18	5.54	5.54	11.72	12.00	2.77	3.00	17.00
10	3.50	1.50	5.25	2.47	3.00	8.25	12.00	1.23	3.00	16.50
9	5.00	1.50	4.32	1.79	3.00	7.32	12.00	0.89	3.00	16.50
8	6.00	1.00	3.71	1.02	3.00	6.71	12.00	0.51	3.00	16.00
7	7.00	1.00	3.09	0.89	3.00	6.09	12.00	0.45	3.00	16.00
6	8.00	1.00	2.47	0.80	3.00	5.47	6.00	0.40	3.00	10.00
5	9.00	1.00	1.85	0.72	3.00	4.85	6.00	0.36	3.00	10.00
4	9.75	0.75	1.39	0.51	3.00	4.39	6.00	0.25	3.00	9.75
3	10.50	0.75	0.93	0.48	3.00	3.93	6.00	0.24	3.00	9.75
2	11.25	0.75	0.46	0.46	3.00	3.46	6.00	0.23	3.00	9.75
1	12.00	0.75	0.00	0.43	3.00	3.00	6.00	0.22	3.00	9.75

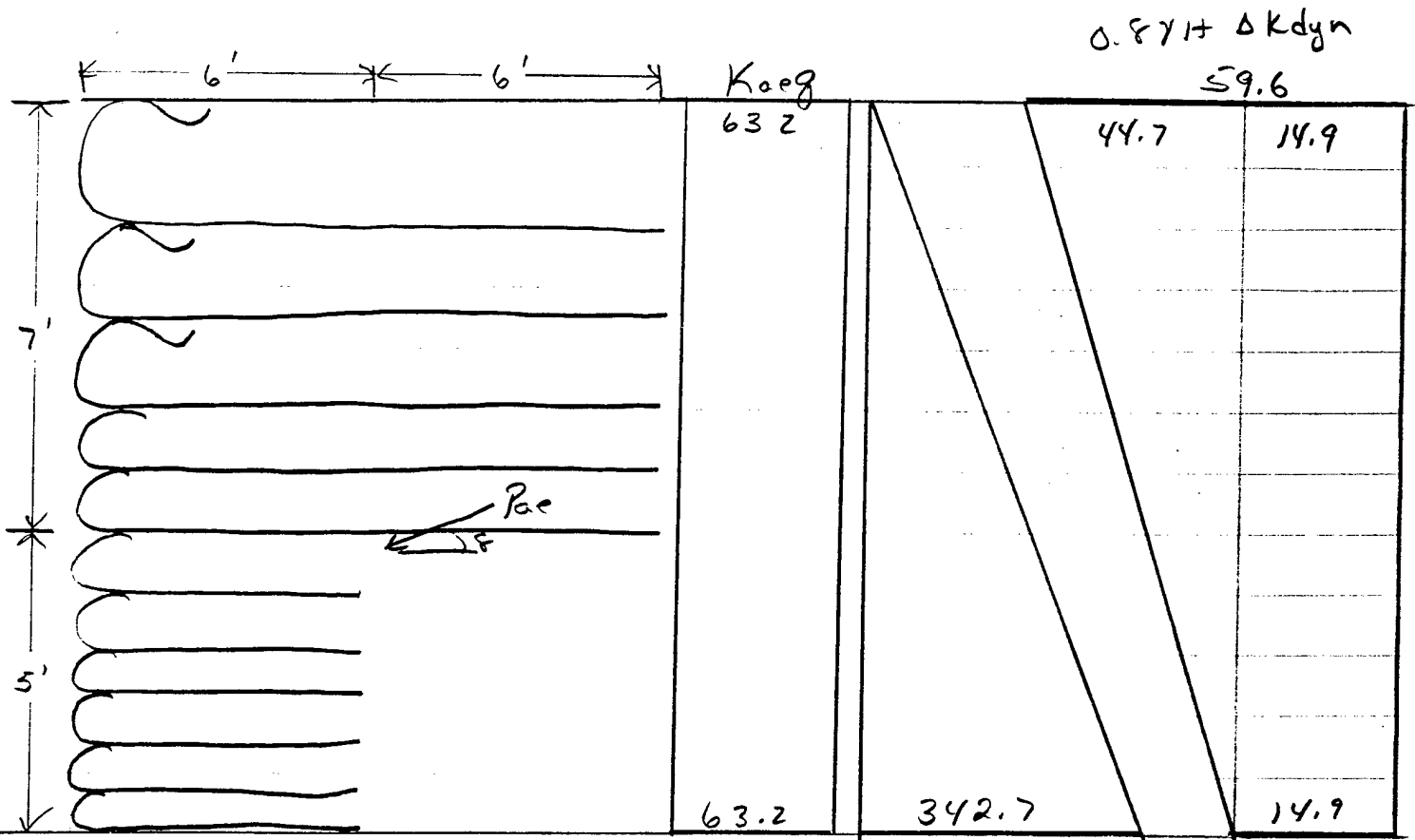

$$\begin{aligned}
 P_g &= 63.2(12) = 758.4 & @ & \frac{1}{2}H = 6 \\
 P_a &= \frac{1}{2}(342.7)(12) = 2056.2 & @ & \frac{1}{3}H = 4 \\
 P_{dyn1} &= \frac{1}{2}(44.7)(12) = 268.2 & @ & \frac{2}{3}H = 8 \\
 P_{dyn2} &= 14.9(12) = 178.8 & @ & \frac{1}{2}H = 6 \\
 P_{ae} &= 3261.6 & @ & h = 4.98'
 \end{aligned}$$

$$P_{ae} \sin \phi = 1917.1$$

$$P_{ae} \cos \phi = 2638.7$$

overturning:

$$FSOT = \frac{7(12)(110)(6) + 5(6)(110)(3) + 1917.7(6)}{2638.7(4.9)} = 5.94 > 3 \quad \Delta K$$

Sliding

$$FS_s = \frac{(320 + \frac{7(12)(110) + 5(6)(110) + 1917.7}{6} \tan 24)}{6}$$

2638.7

= 3.17 > 3.0 OK

Layer No.	Depth z (ft)	Spacing Sv (ft)	Embedment	Overlap	Cut
			Length Lt (ft)	Length Lo (ft)	Length Lc (ft)
11	2.00	2.00	12	3	17.00
10	3.50	1.50	12	3	16.50
9	5.00	1.50	12	3	16.50
8	6.00	1.00	12	3	16.00
7	7.00	1.00	12	3	16.00
6	8.00	1.00	6	3	10.00
5	9.00	1.00	6	3	10.00
4	9.75	0.75	6	3	9.75
3	10.50	0.75	6	3	9.75
2	11.25	0.75	6	3	9.75
1	12.00	0.75	6	3	9.75
<b>Total Fabric Length per Linear foot of wall (ft/ft)</b>					<b>141.00</b>

~~STATIC CASE~~ Extended Koerner

①

Example problem p. 199

! modified  
 $q = 200 \text{ lb/ft}^2$

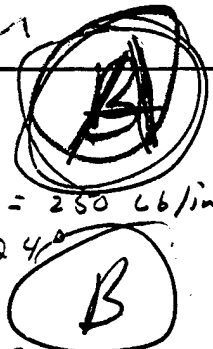

$H = 12'$

$\gamma = 110 \text{ lb/ft}^3$   
 $\phi = 36^\circ$   
 $c = 0 \text{ lb/ft}^2$

$K_h = 0.0$   $T_{ult} = 250 \text{ lb/in}$   
 $S = 24'$   
 $F_s = 1.3$

external  
 stability

a) Determine horizontal pressure as a function of Depth (z)

$K_a = \tan^2(45 - \phi/2) = \tan^2(45 - 36/2) = 0.2596$

$T_h = T_{hs} + T_{ha}$   
 $= K_a \gamma z + K_a q$

$= 0.2596(110)z + 0.2596(200) = 28.556z + 51.92$

$T_{allow} = \frac{T_{ult}}{(F_{sid} + F_{ser} + F_{scd} + F_{sbd})} = \frac{250 \text{ lb/in} \times 12 \text{ in/ft}}{(1.5 \times 3.0 \times 1.25 \times 1.1)}$   
 $= 484.85 \text{ lbs/ft}$

$S_v = \frac{T_{allow}}{F_s (T_h)} = \frac{484.85}{1.3 (28.556z + 51.92)}$

Example problem page 199 (static case)

Depth z (ft)	Sigma hs (lb/ft <sup>2</sup> )	Sigma ha (lb/ft <sup>2</sup> )	Sigma h (lb/ft <sup>2</sup> )	Sv (ft)	Use (ft)
1	28.56	51.92	80.48	4.63	1.5
2	57.12	51.92	109.04	3.42	1.5
3	85.67	51.92	137.60	2.71	1.5
4	114.23	51.92	166.15	2.24	1.5
5	142.79	51.92	194.71	1.92	1.5
6	171.35	51.92	223.27	1.67	1.5
7	199.90	51.92	251.83	1.48	1.0
8	228.46	51.92	280.39	1.33	1.0
9	257.02	51.92	308.94	1.21	1.0
10	285.58	51.92	337.50	1.11	1.0
11	314.14	51.92	366.06	1.02	1.0
12	342.69	51.92	394.62	0.95	1.0

Reduced to 1.5' and 1' respectively for design and construction simplicity.

b) Determine Fabric Length

$$L_R = (H - z) \tan(45 - \phi/2)$$

$$= (12 - z) \tan(45 - 36/2)$$

$$= 0.5095 (12 - z)$$

$$L = L_c + L_e$$

↑                      ↑  
embedment            NON-Anchoring

$$L_c = \frac{S_v \sigma_h (F_s)}{2(C + \gamma z + \alpha \sigma_h)}$$

$$= \frac{S_v (28.556 z + 51.92)(1.3)}{2(110 z + \alpha 24)}$$

$$= \frac{S_v (28.556 z + 51.92)}{75.35 z}$$

$$L_o = \frac{S_v \sigma_h (F_s)}{4(C + \gamma z + \alpha \sigma_h)} = \frac{S_v (28.556 z + 51.92)(1.3)}{4(110 z + \alpha 24)}$$

Layer No.	Depth z (ft)	Spacing Sv (ft)	Lr (ft)	Le (calc) (ft)	Le (min) (ft)	L (calc) (ft)	L (use) (ft)	Lo (calc) (ft)	Lo (use) (ft)	Lc (ft)
10	1.5	1.5	5.35	1.26	3.00	8.35	9.00	0.63	3.00	13.50
9	3.0	1.5	4.59	0.91	3.00	7.59	9.00	0.46	3.00	13.50
8	4.5	1.5	3.82	0.80	3.00	6.82	9.00	0.40	3.00	13.50
7	6.0	1.5	3.06	0.74	3.00	6.06	9.00	0.37	3.00	13.50
6	7.0	1	2.55	0.48	3.00	5.55	9.00	0.24	3.00	13.00
5	8.0	1	2.04	0.47	3.00	5.04	5.00	0.23	3.00	9.00
4	9.0	1	1.53	0.46	3.00	4.53	5.00	0.23	3.00	9.00
3	10.0	1	1.02	0.45	3.00	4.02	5.00	0.22	3.00	9.00
2	11.0	1	0.51	0.44	3.00	3.51	5.00	0.22	3.00	9.00
1	12.0	1	0.00	0.44	3.00	3.00	5.00	0.22	3.00	9.00

50 SHEETS  
22-141 100 SHEETS  
22-142 200 SHEETS  
22-144



$$W_1 = 12 \times 5 \times 110 = 6600$$

$$W_2 = 4 \times 5 \times 110 = 4400$$

$$x_1 = 2.5' \pm$$

$$x_2 = 7.5' \pm$$

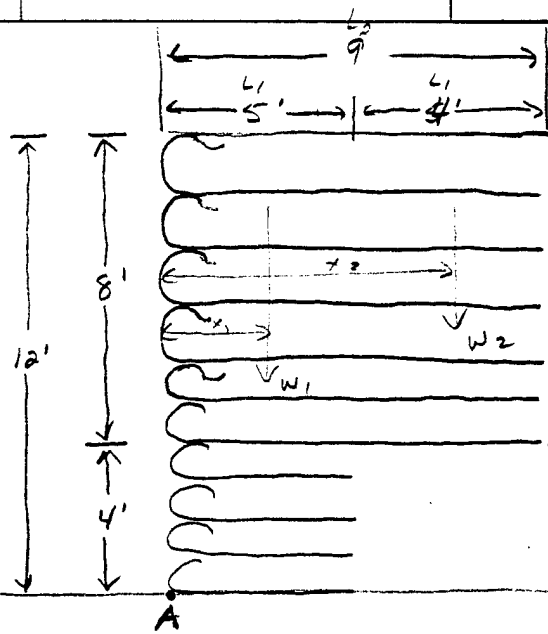

$\gamma = 110 \text{ lbs/ft}^3$   
 $\phi = 36^\circ$   
 $\delta_1 = 36^\circ$   
 $C = 0$   
 $K_a = 0.2596$

Foundation Soil  
 $\gamma = 115 \text{ lbs/ft}^3$   
 $\phi = 15^\circ$   
 $\delta_2 = 0.95\phi = 14.25$   
 $C = 400 \text{ lb/ft}^2$   
 $C_c = 0.8C = 320 \text{ lb/ft}^2$

$$P_a = 0.5 \gamma H^2 / K_a$$

$$= 0.5 (110) (12^2) (0.2596)$$

$$= 2056 \text{ lb/ft}$$

$$P_g = 200 (.2596)$$

$$= 51.92$$

$$= 52$$

$$P_t = P_a + P_g = 2108$$

$$P_t \sin \phi = 1239 \quad P_t \cos \phi = 1705$$

Overturning moments about point A

$$FSOT = \frac{\sum \text{Resisting moments}}{\sum \text{Driving moments}}$$

$$= \frac{W_1 x_1 + W_2 x_2 + P_a \sin \delta (10)}{P_a \cos \delta (4)}$$

$$= \frac{4(5)(110)(2.5) + 8(9)(4.5)(110) + 1239(9)}{1705(4)}$$

$$= 7.67 > 3 \quad \text{OK!}$$

Sliding at the base

$$FS_s = \frac{\text{Resisting forces}}{\text{Driving forces}}$$

$$= \frac{(c_u + \frac{W_1 + W_2 + Pa \sin \theta}{L_1}) \tan \delta_z}{Pa \cos \theta} L_1$$

$$Pa \cos \theta$$

$$= \frac{[320 + (\frac{475 \times 110 + 829 \times 110 + 1239}{5}) \tan(24)]}{5}$$

$$1705$$

$$= 3.90 > 3 \quad \text{OK}$$

Layer No.	Depth z (ft)	Spacing Sv (ft)	Embedment	Overlap	Cut
			Length Lt (ft)	Length Lo (ft)	Length Lc (ft)
10	1.50	1.50	9.00	3.00	13.50
9	3.00	1.50	9.00	3.00	13.50
8	4.50	1.50	9.00	3.00	13.50
7	6.00	1.50	9.00	3.00	13.50
6	7.00	1.00	9.00	3.00	13.00
5	8.00	1.00	5.00	3.00	9.00
4	9.00	1.00	5.00	3.00	9.00
3	10.00	1.00	5.00	3.00	9.00
2	11.00	1.00	5.00	3.00	9.00
1	12.00	1.00	5.00	3.00	9.00
<b>Total Fabric Length per Linear foot of wall (ft/ft)</b>					<b>112.00</b>





## APPENDIX C

Extended Rankine method

(C)

$$k_h = 0.5$$

Depth z (ft)	Sigma q (lb/ft <sup>2</sup> )	Sigma s (lb/ft <sup>2</sup> )	Delta Sigma dyn (lb/ft <sup>2</sup> )	SIGMA d (lb/ft <sup>2</sup> )	Sv Sv (ft)	Sv Use (ft)	Sv Use (inch)
0	138.40	0.0	456.6	595.0	0.63	0.580	7.0
1	138.40	28.6	428.1	595.0	0.63	0.580	7.0
2	138.40	57.1	399.5	595.0	0.63	0.580	7.0
3	138.40	85.7	371.0	595.1	0.63	0.580	7.0
4	138.40	114.2	342.5	595.1	0.63	0.580	7.0
5	138.40	142.8	313.9	595.1	0.63	0.580	7.0
6	138.40	171.3	285.4	595.1	0.63	0.580	7.0
7	138.40	199.9	256.8	595.1	0.63	0.580	7.0
8	138.40	228.4	228.3	595.2	0.63	0.580	7.0
9	138.40	257.0	199.8	595.2	0.63	0.580	7.0
10	138.40	285.6	171.2	595.2	0.63	0.580	7.0
11	138.40	314.1	142.7	595.2	0.63	0.580	7.0
12	138.40	342.7	114.2	595.2	0.63	0.580	7.0

Layer No.	Depth z (ft)	Spacing Sv (ft)	Nonresisting Length		Resisting Length		Total Embedment Length		Overlap Length		Cut Length Lc (ft)
			Lr (ft)	Le (calc) (ft)	Le (min) (ft)	Lt (calc) (ft)	Lt (use) (ft)	Lo (calc) (ft)	Lo (use) (ft)		
21	0.58	0.58	5.82	5.35	5.35	11.17	12.00	2.67	3.00	15.58	
20	1.16	0.58	5.52	2.71	3.00	8.52	12.00	1.36	3.00	15.58	
19	1.74	0.58	5.23	1.84	3.00	8.23	12.00	0.92	3.00	15.58	
18	2.32	0.58	4.93	1.40	3.00	7.93	12.00	0.70	3.00	15.58	
17	2.90	0.58	4.64	1.13	3.00	7.64	12.00	0.57	3.00	15.58	
16	3.48	0.58	4.34	0.96	3.00	7.34	12.00	0.48	3.00	15.58	
15	4.06	0.58	4.05	0.83	3.00	7.05	12.00	0.42	3.00	15.58	
14	4.64	0.58	3.75	0.74	3.00	6.75	12.00	0.37	3.00	15.58	
13	5.22	0.58	3.45	0.67	3.00	6.45	12.00	0.33	3.00	15.58	
12	5.80	0.58	3.16	0.61	3.00	6.16	12.00	0.30	3.00	15.58	
11	6.38	0.58	2.86	0.56	3.00	5.86	6.00	0.28	3.00	9.58	
10	6.96	0.58	2.57	0.52	3.00	5.57	6.00	0.26	3.00	9.58	
9	7.54	0.58	2.27	0.49	3.00	5.27	6.00	0.24	3.00	9.58	
8	8.12	0.58	1.98	0.46	3.00	4.98	6.00	0.23	3.00	9.58	
7	8.70	0.58	1.68	0.43	3.00	4.68	6.00	0.22	3.00	9.58	
6	9.28	0.58	1.39	0.41	3.00	4.39	6.00	0.20	3.00	9.58	
5	9.86	0.58	1.09	0.39	3.00	4.09	6.00	0.20	3.00	9.58	
4	10.44	0.58	0.79	0.37	3.00	3.79	6.00	0.19	3.00	9.58	
3	11.02	0.58	0.50	0.36	3.00	3.50	6.00	0.18	3.00	9.58	
2	11.60	0.58	0.20	0.34	3.00	3.20	6.00	0.17	3.00	9.58	
1	12.00	0.40	0.00	0.23	3.00	3.00	6.00	0.12	3.00	9.40	

$$P_{ac} = 7141.8 @ 6$$

Overturning

$$FS_{OT} = \frac{12(5.8)(110)(6) + 6(6.2)(110)(3)}{7141.8(6)} = 1.36 \quad \text{NO GOOD}$$

increase All layers to 14'

$$FS_{OT} = 3.02 \quad \text{OK!}$$

Sliding :

$$FS_{SL} = \frac{\left( 320 + \frac{12(14)(110) \tan 24}{14} \right) 14}{7141.8} = 1.78 \quad \text{NO GOOD}$$

increase All layers to 24'

$$FS_{SL} = 3.05 > 3 \quad \text{OK!}$$

Layer No.	Depth z (ft)	Spacing Sv (ft)	Embedment	Overlap	Cut
			Length Lt (ft)	Length Lo (ft)	Length Lc (ft)
21	0.58	0.58	24	3	27.58
20	1.16	0.58	24	3	27.58
19	1.74	0.58	24	3	27.58
18	2.32	0.58	24	3	27.58
17	2.90	0.58	24	3	27.58
16	3.48	0.58	24	3	27.58
15	4.06	0.58	24	3	27.58
14	4.64	0.58	24	3	27.58
13	5.22	0.58	24	3	27.58
12	5.80	0.58	24	3	27.58
11	6.38	0.58	24	3	27.58
10	6.96	0.58	24	3	27.58
9	7.54	0.58	24	3	27.58
8	8.12	0.58	24	3	27.58
7	8.70	0.58	24	3	27.58
6	9.28	0.58	24	3	27.58
5	9.86	0.58	24	3	27.58
4	10.44	0.58	24	3	27.58
1	11.02	0.58	24	3	27.58
<b>Total Fabric Length per Linear foot of wall (ft/ft)</b>					<b>524.02</b>

Extended Rankine



$$K_h = 0.4$$

Depth z (ft)	Sigma q (lb/ft <sup>2</sup> )	Sigma s (lb/ft <sup>2</sup> )	Delta Sigma dyn (lb/ft <sup>2</sup> )	SIGMA d (lb/ft <sup>2</sup> )	Sv (ft)	Sv Use (ft)	Sv Use (inch)
0	106.90	0.0	290.3	397.2	0.94	0.667	8.0
1	106.90	28.6	272.2	407.6	0.91	0.667	8.0
2	106.90	57.1	254.0	418.0	0.89	0.667	8.0
3	106.90	85.7	235.9	428.4	0.87	0.667	8.0
4	106.90	114.2	217.7	438.8	0.85	0.667	8.0
5	106.90	142.8	199.6	449.3	0.83	0.667	8.0
6	106.90	171.3	181.4	459.7	0.81	0.667	8.0
7	106.90	199.9	163.3	470.1	0.79	0.667	8.0
8	106.90	228.4	145.1	480.5	0.78	0.667	8.0
9	106.90	257.0	127.0	490.9	0.76	0.667	8.0
10	106.90	285.6	108.9	501.3	0.74	0.667	8.0
11	106.90	314.1	90.7	511.7	0.73	0.667	8.0
12	106.90	342.7	72.6	522.1	0.71	0.667	8.0

Layer No.	Depth z (ft)	Spacing Sv (ft)	Nonresisting Length	Resisting Length		Total Embedment Length		Overlap Length		Cut Length
			Lr (ft)	Le (calc) (ft)	Le (min) (ft)	Lt (calc) (ft)	Lt (use) (ft)	Lo (calc) (ft)	Lo (use) (ft)	Lc (ft)
18	0.67	0.67	5.77	5.36	5.36	11.13	12.00	2.68	3.00	15.67
17	1.34	0.67	5.43	2.73	3.00	8.43	12.00	1.36	3.00	15.67
16	2.01	0.67	5.09	1.85	3.00	8.09	12.00	0.92	3.00	15.67
15	2.68	0.67	4.75	1.41	3.00	7.75	12.00	0.70	3.00	15.67
14	3.35	0.67	4.41	1.15	3.00	7.41	12.00	0.57	3.00	15.67
13	4.02	0.67	4.07	0.97	3.00	7.07	12.00	0.49	3.00	15.67
12	4.69	0.67	3.72	0.85	3.00	6.72	12.00	0.42	3.00	15.67
11	5.36	0.67	3.38	0.75	3.00	6.38	12.00	0.38	3.00	15.67
10	6.03	0.67	3.04	0.68	3.00	6.04	6.00	0.34	3.00	9.67
9	6.70	0.67	2.70	0.62	3.00	5.70	6.00	0.31	3.00	9.67
8	7.37	0.67	2.36	0.57	3.00	5.36	6.00	0.29	3.00	9.67
7	8.04	0.67	2.02	0.53	3.00	5.02	6.00	0.27	3.00	9.67
6	8.71	0.67	1.68	0.50	3.00	4.68	6.00	0.25	3.00	9.67
5	9.38	0.67	1.33	0.47	3.00	4.33	6.00	0.23	3.00	9.67
4	10.05	0.67	0.99	0.44	3.00	3.99	6.00	0.22	3.00	9.67
3	10.72	0.67	0.65	0.42	3.00	3.65	6.00	0.21	3.00	9.67
2	11.39	0.67	0.31	0.40	3.00	3.31	6.00	0.20	3.00	9.67
1	12.00	0.67	0.00	0.39	3.00	3.00	6.00	0.19	3.00	9.67

## Overturning

$$P_{ac} = 5516.4 \quad @ \quad h = 5.73$$

$$FS_{OT} = \frac{5.36(12)(110) + 6.64(6)3(110)}{5516.4(5.73)} = 1.76 \quad \text{NO good!}$$

increase all layers to 12'

$$FS_{OT} = 3.01 \quad \text{OK!}$$

## Sliding

$$FS_{SL} = \frac{\left( 320 + \frac{12(12)110 + 24}{12} \right) 12}{5516.4} = 1.97 \quad \text{NO good!}$$

increase all layers ~~to~~ to 19'

$$FS_{SL} = 3.13 \quad \text{OK!}$$

Layer No.	Depth z (ft)	Spacing Sv (ft)	Embedment Length Lt (ft)	Overlap Length Lo (ft)	Cut Length Lc (ft)
18	0.67	0.67	19	3	22.67
17	1.34	0.67	19	3	22.67
16	2.01	0.67	19	3	22.67
15	2.68	0.67	19	3	22.67
14	3.35	0.67	19	3	22.67
13	4.02	0.67	19	3	22.67
12	4.69	0.67	19	3	22.67
11	5.36	0.67	19	3	22.67
10	6.03	0.67	19	3	22.67
9	6.70	0.67	19	3	22.67
8	7.37	0.67	19	3	22.67
7	8.04	0.67	19	3	22.67
6	8.71	0.67	19	3	22.67
5	9.38	0.67	19	3	22.67
4	10.05	0.67	19	3	22.67
3	10.72	0.67	19	3	22.67
2	11.39	0.67	19	3	22.67
1	12.00	0.67	19	3	22.67
<b>Total Fabric Length per Linear foot of wall (ft/ft)</b>					<b>408.06</b>

# Cartesian Rankine method

©

$$k_h = 0.3$$

Depth z (ft)	Sigma q (lb/ft <sup>2</sup> )	Sigma s (lb/ft <sup>2</sup> )	Delta Sigma dyn (lb/ft <sup>2</sup> )	SIGMA d (lb/ft <sup>2</sup> )	Sv (ft)	Sv Use (ft)	Sv Use (inch)
0	92.48	0.0	214.2	306.6	1.22	1.000	12.0
1	92.48	28.6	200.8	321.8	1.16	1.000	12.0
2	92.48	57.1	187.4	337.0	1.11	1.000	12.0
3	92.48	85.7	174.0	352.2	1.06	1.000	12.0
4	92.48	114.2	160.6	367.3	1.02	1.000	12.0
5	92.48	142.8	147.2	382.5	0.98	0.750	9.0
6	92.48	171.3	133.8	397.7	0.94	0.750	9.0
7	92.48	199.9	120.5	412.8	0.90	0.750	9.0
8	92.48	228.4	107.1	428.0	0.87	0.750	9.0
9	92.48	257.0	93.7	443.2	0.84	0.750	9.0
10	92.48	285.6	80.3	458.3	0.81	0.750	9.0
11	92.48	314.1	66.9	473.5	0.79	0.750	9.0
12	92.48	342.7	53.5	488.7	0.76	0.750	9.0

Layer No.	Depth z (ft)	Spacing Sv (ft)	Nonresisting	Resisting Length		Total Embedment Length		Overlap Length		Cut Length
			Lr (ft)	Le (calc) (ft)	Le (min) (ft)	Lt (calc) (ft)	Lt (use) (ft)	Lo (calc) (ft)	Lo (use) (ft)	Lc (ft)
15	1.00	1.00	5.60	5.41	5.41	11.01	11.00	2.70	3.00	15.00
14	2.00	1.00	5.10	2.77	3.00	8.10	11.00	1.39	3.00	15.00
13	3.00	1.00	4.59	1.89	3.00	7.59	11.00	0.95	3.00	15.00
12	4.00	1.00	4.08	1.46	3.00	7.08	11.00	0.73	3.00	15.00
11	4.75	0.75	3.69	0.94	3.00	6.69	11.00	0.47	3.00	14.75
10	5.50	0.75	3.31	0.82	3.00	6.31	11.00	0.41	3.00	14.75
9	6.25	0.75	2.93	0.74	3.00	5.93	6.00	0.37	3.00	9.75
8	7.00	0.75	2.55	0.67	3.00	5.55	6.00	0.33	3.00	9.75
7	7.75	0.75	2.17	0.61	3.00	5.17	6.00	0.31	3.00	9.75
6	8.50	0.75	1.78	0.57	3.00	4.78	6.00	0.28	3.00	9.75
5	9.25	0.75	1.40	0.53	3.00	4.40	6.00	0.27	3.00	9.75
4	10.00	0.75	1.02	0.50	3.00	4.02	6.00	0.25	3.00	9.75
3	10.75	0.75	0.64	0.47	3.00	3.64	6.00	0.24	3.00	9.75
2	11.50	0.75	0.25	0.45	3.00	3.25	6.00	0.22	3.00	9.75
1	12.00	0.50	0.00	0.29	3.00	3.00	6.00	0.14	3.00	9.50



## Overturning

$$P_{ac} = 4773.0 \quad \odot \quad 5.54'$$

$$FSOT = \frac{11(5.5)(110)(5.5) + 6(6.5)110(30)}{4773(5.54)} = 1.87 \text{ NO GOOD}$$

increase bottom layers to 11'

$$FSOT = 3.02$$

$$FS_{sc} = \frac{(320 + 12(110) \tan 24)11}{4773} = 2.09 \text{ NO GOOD}$$

increase all layers to 16'

$$FS_{sc} = 3.04 \text{ OK}$$

Layer No.	Depth z (ft)	Spacing Sv (ft)	Embedment Length Lt (ft)	Overlap Length Lo (ft)	Cut Length Lc (ft)
15	1.00	1.00	16	3	20.00
14	2.00	1.00	16	3	20.00
13	3.00	1.00	16	3	20.00
12	4.00	1.00	16	3	20.00
11	4.75	0.75	16	3	19.75
10	5.50	0.75	16	3	19.75
9	6.25	0.75	16	3	19.75
8	7.00	0.75	16	3	19.75
7	7.75	0.75	16	3	19.75
6	8.50	0.75	16	3	19.75
5	9.25	0.75	16	3	19.75
4	10.00	0.75	16	3	19.75
3	10.75	0.75	16	3	19.75
2	11.50	0.75	16	3	19.75
1	12.00	0.50	16	3	19.50
<b>Total Fabric Length per Linear foot of wall (ft/ft)</b>					<b>297.00</b>

# Extended Rankine Method



$$K_h = 0.2$$

Depth z (ft)	Sigma q (lb/ft <sup>2</sup> )	Sigma s (lb/ft <sup>2</sup> )	Delta Sigma dyn (lb/ft <sup>2</sup> )	SIGMA d (lb/ft <sup>2</sup> )	Sv Sv (ft)	Sv Use (ft)	Sv Use (inch)
0	78.64	0.0	141.1	219.7	1.70	1.500	18.0
1	78.64	28.6	132.3	239.5	1.56	1.500	18.0
2	78.64	57.1	123.4	259.2	1.44	1.000	12.0
3	78.64	85.7	114.6	278.9	1.34	1.000	12.0
4	78.64	114.2	105.8	298.7	1.25	1.000	12.0
5	78.64	142.8	97.0	318.4	1.17	1.000	12.0
6	78.64	171.3	88.2	338.2	1.10	1.000	12.0
7	78.64	199.9	79.4	357.9	1.04	1.000	12.0
8	78.64	228.4	70.5	377.6	0.99	0.750	9.0
9	78.64	257.0	61.7	397.4	0.94	0.750	9.0
10	78.64	285.6	52.9	417.1	0.89	0.750	9.0
11	78.64	314.1	44.1	436.8	0.85	0.750	9.0
12	78.64	342.7	35.3	456.6	0.82	0.750	9.0

Layer No.	Depth z (ft)	Spacing Sv (ft)	Nonresisting Length	Resisting Length		Total Embedment Length		Overlap Length		Cut Length
			Lr (ft)	Le (calc) (ft)	Le (min) (ft)	Lt (calc) (ft)	Lt (use) (ft)	Lo (calc) (ft)	Lo (use) (ft)	Lc (ft)
13	1.50	1.50	5.35	5.48	5.48	10.83	11.00	2.74	3.00	15.50
12	2.50	1.00	4.84	2.25	3.00	7.84	11.00	1.12	3.00	15.00
11	3.50	1.00	4.33	1.64	3.00	7.33	11.00	0.82	3.00	15.00
10	4.50	1.00	3.82	1.31	3.00	6.82	11.00	0.65	3.00	15.00
9	5.50	1.00	3.31	1.10	3.00	6.31	11.00	0.55	3.00	15.00
8	6.50	1.00	2.80	0.95	3.00	5.80	6.00	0.47	3.00	10.00
7	7.50	1.00	2.29	0.84	3.00	5.29	6.00	0.42	3.00	10.00
6	8.25	0.75	1.91	0.58	3.00	4.91	6.00	0.29	3.00	9.75
5	9.00	0.75	1.53	0.54	3.00	4.53	6.00	0.27	3.00	9.75
4	9.75	0.75	1.15	0.51	3.00	4.15	6.00	0.25	3.00	9.75
3	10.50	0.75	0.76	0.48	3.00	3.76	6.00	0.24	3.00	9.75
2	11.25	0.75	0.38	0.46	3.00	3.38	6.00	0.23	3.00	9.75
1	12.00	0.75	0.00	0.43	3.00	3.00	6.00	0.22	3.00	9.75

Overturning

$$P_{ac} = 4057.8$$

$$FS_{OT} = \frac{11(5.5)(110)(5.5) + 6.5(6)(110)(6.3)}{4057.8} = 2.30 < 3$$

NO  
good

increase Bottom layers to 9'

$$FS_{OT} = 3.05$$

Sliding

$$FS_{SL} = \frac{\left( 320 + \frac{11(5.5)(110) + 6.5(9)(110)}{9} + 24 \right) 9}{4057.8} = 2.15$$

NO  
good

increase all layers to 14'

$$FS_{SL} = 3.13$$

Layer No.	Depth z (ft)	Spacing Sv (ft)	Embedment	Overlap	Cut
			Length Lt (ft)	Length Lo (ft)	Length Lc (ft)
13	1.50	1.50	14	3	18.50
12	2.50	1.00	14	3	18.00
11	3.50	1.00	14	3	18.00
10	4.50	1.00	14	3	18.00
9	5.50	1.00	14	3	18.00
8	6.50	1.00	14	3	18.00
7	7.50	1.00	14	3	18.00
6	8.25	0.75	14	3	17.75
5	9.00	0.75	14	3	17.75
4	9.75	0.75	14	3	17.75
3	10.50	0.75	14	3	17.75
2	11.25	0.75	14	3	17.75
1	12.00	0.75	14	3	17.75
Total Fabric Length per Linear foot of wall (ft/ft)					233.00

# Extended Koerner method

©

$$k_H = 0.1$$

Depth z (ft)	Sigma q (lb/ft <sup>2</sup> )	Sigma s (lb/ft <sup>2</sup> )	Delta Sigma dyn (lb/ft <sup>2</sup> )	SIGMA d (lb/ft <sup>2</sup> )	Sv (ft)	Sv Use (ft)	Sv Use (inch)
0	63.20	0.0	59.6	122.8	3.04	2.000	24.0
1	63.20	28.6	55.8	147.6	2.53	2.000	24.0
2	63.20	57.1	52.1	172.4	2.16	2.000	24.0
3	63.20	85.7	48.4	197.3	1.89	1.500	18.0
4	63.20	114.2	44.7	222.1	1.68	1.500	18.0
5	63.20	142.8	40.9	246.9	1.51	1.500	18.0
6	63.20	171.3	37.2	271.8	1.37	1.000	12.0
7	63.20	199.9	33.5	296.6	1.26	1.000	12.0
8	63.20	228.4	29.8	321.4	1.16	1.000	12.0
9	63.20	257.0	26.1	346.3	1.08	1.000	12.0
10	63.20	285.6	22.3	371.1	1.01	0.750	9.0
11	63.20	314.1	18.6	395.9	0.94	0.750	9.0
12	63.20	342.7	14.9	420.8	0.89	0.750	9.0

Layer No.	Depth z (ft)	Spacing Sv (ft)	Nonresisting Length	Resisting Length		Total Embedment Length		Overlap Length		Cut Length
			Lr (ft)	Le (calc) (ft)	Le (min) (ft)	Lt (calc) (ft)	Lt (use) (ft)	Lo (calc) (ft)	Lo (use) (ft)	Lc (ft)
11	2.00	2.00	5.10	5.54	5.54	10.64	10.00	2.77	3.00	15.00
10	3.50	1.50	4.33	2.47	3.00	7.33	10.00	1.23	3.00	14.50
9	5.00	1.50	3.57	1.79	3.00	6.57	10.00	0.89	3.00	14.50
8	6.00	1.00	3.06	1.02	3.00	6.06	10.00	0.51	3.00	14.00
7	7.00	1.00	2.55	0.89	3.00	5.55	10.00	0.45	3.00	14.00
6	8.00	1.00	2.04	0.80	3.00	5.04	5.00	0.40	3.00	9.00
5	9.00	1.00	1.53	0.72	3.00	4.53	5.00	0.36	3.00	9.00
4	9.75	0.75	1.15	0.51	3.00	4.15	5.00	0.25	3.00	8.75
3	10.50	0.75	0.76	0.48	3.00	3.76	5.00	0.24	3.00	8.75
2	11.25	0.75	0.38	0.46	3.00	3.38	5.00	0.23	3.00	8.75
1	12.00	0.75	0.00	0.43	3.00	3.00	5.00	0.22	3.00	8.75

Overturning

$$P_{ac} = 3261.6 \text{ @ } h = 4.90$$

$$FS_{OT} = \frac{10(7)(110)(5) + 5(5)(110)(2.5)}{3261.6 (4.90)} = 2.84 < 3$$

NO good

increase bottom layers to 6'

$$FS_{OT} = 3.03$$

$$FS_{SL} = \frac{\left( 320 + \frac{(10(7)110 + 6(5)110) + 24}{6} \right)}{3261.6} = 2.09 < 3$$

NO good

Increase all layers to 11'

$$FS_{SL} = 3.06 \text{ OK}$$

Layer No.	Depth z (ft)	Spacing Sv (ft)	Embedment	Overlap	Cut
			Length Lt (ft)	Length Lo (ft)	Length Lc (ft)
11	2.00	2.00	11	3	16.00
10	3.50	1.50	11	3	15.50
9	5.00	1.50	11	3	15.50
8	6.00	1.00	11	3	15.00
7	7.00	1.00	11	3	15.00
6	8.00	1.00	11	3	15.00
5	9.00	1.00	11	3	15.00
4	9.75	0.75	11	3	14.75
3	10.50	0.75	11	3	14.75
2	11.25	0.75	11	3	14.75
1	12.00	0.75	11	3	14.75
<b>Total Fabric Length per Linear foot of wall (ft/ft)</b>					<b>166.00</b>



## APPENDIX D

Rawkin ~~Method~~ Method

$\frac{K_{12}}{K_1} = 0.5$

$P_{6ft} = 16.1 \text{ ft/sec}^2 \quad K_{12} = 0.5 \quad P = 33.90$

$K_{ac} = 0.6920$

$K_a = 0.2596$

$\Delta K_{dyn} = 0.4324$

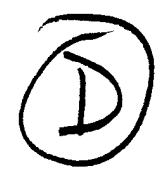

$\Delta d = 138.4 + 28.6z + 47.6(9.6 - 0.6z)$

$S_r = \frac{484.85}{1.3 [138.4 + 28.6z + 47.6(9.6 - 0.6z)]}$

Depth z (ft)	Sigma q (lb/ft <sup>2</sup> )	Sigma s (lb/ft <sup>2</sup> )	Delta Sigma dyn (lb/ft <sup>2</sup> )	SIGMA d (lb/ft <sup>2</sup> )	Sv (ft)	Sv Use (ft)	Sv Use (inch)
0	138.40	0.0	456.6	595.0	0.63	0.580	7.0
1	138.40	28.6	428.1	595.0	0.63	0.580	7.0
2	138.40	57.1	399.5	595.0	0.63	0.580	7.0
3	138.40	85.7	371.0	595.1	0.63	0.580	7.0
4	138.40	114.2	342.5	595.1	0.63	0.580	7.0
5	138.40	142.8	313.9	595.1	0.63	0.580	7.0
6	138.40	171.3	285.4	595.1	0.63	0.580	7.0
7	138.40	199.9	256.8	595.1	0.63	0.580	7.0
8	138.40	228.4	228.3	595.2	0.63	0.580	7.0
9	138.40	257.0	199.8	595.2	0.63	0.580	7.0
10	138.40	285.6	171.2	595.2	0.63	0.580	7.0
11	138.40	314.1	142.7	595.2	0.63	0.580	7.0
12	138.40	342.7	114.2	595.2	0.63	0.580	7.0

# Fabric Length

$$L_r = (12-z) 1.488$$

$$L_c = \frac{S_v \left[ 138.4 + 28.6z + 47.6(9.6 - 0.6z) \right]}{2(110)(z) \tan 24}$$

$$L_t = L_r + L_c$$

$$L_o = \frac{1}{2} L_c \geq 3.0'$$

$$L_c = L_t + L_o + S_v$$

Layer No.	Depth z (ft)	Spacing Sv (ft)	Nonresisting	Resisting Length		Total Embedment		Overlap Length		Cut
			Length Lr (ft)	Le (calc) (ft)	Le (min) (ft)	Lt (calc) (ft)	Lt (use) (ft)	Lo (calc) (ft)	Lo (use) (ft)	Length Lc (ft)
21	0.58	0.58	16.99	5.35	5.35	22.34	23.00	2.67	3.00	26.58
20	1.16	0.58	16.13	2.71	3.00	19.13	23.00	1.36	3.00	26.58
19	1.74	0.58	15.27	1.84	3.00	18.27	23.00	0.92	3.00	26.58
18	2.32	0.58	14.41	1.40	3.00	17.41	18.00	0.70	3.00	21.58
17	2.90	0.58	13.54	1.13	3.00	16.54	18.00	0.57	3.00	21.58
16	3.48	0.58	12.68	0.96	3.00	15.68	18.00	0.48	3.00	21.58
15	4.06	0.58	11.82	0.83	3.00	14.82	18.00	0.42	3.00	21.58
14	4.64	0.58	10.95	0.74	3.00	13.95	18.00	0.37	3.00	21.58
13	5.22	0.58	10.09	0.67	3.00	13.09	18.00	0.33	3.00	21.58
12	5.80	0.58	9.23	0.61	3.00	12.23	18.00	0.30	3.00	21.58
11	6.38	0.58	8.36	0.56	3.00	11.36	18.00	0.28	3.00	21.58
10	6.96	0.58	7.50	0.52	3.00	10.50	18.00	0.26	3.00	21.58
9	7.54	0.58	6.64	0.49	3.00	9.64	10.00	0.24	3.00	13.58
8	8.12	0.58	5.77	0.46	3.00	8.77	10.00	0.23	3.00	13.58
7	8.70	0.58	4.91	0.43	3.00	7.91	10.00	0.22	3.00	13.58
6	9.28	0.58	4.05	0.41	3.00	7.05	10.00	0.20	3.00	13.58
5	9.86	0.58	3.18	0.39	3.00	6.18	10.00	0.20	3.00	13.58
4	10.44	0.58	2.32	0.37	3.00	5.32	10.00	0.19	3.00	13.58
3	11.02	0.58	1.46	0.36	3.00	4.46	10.00	0.18	3.00	13.58
2	11.60	0.58	0.60	0.34	3.00	3.60	10.00	0.17	3.00	13.58
1	12.00	0.40	0.00	0.23	3.00	3.00	10.00	0.12	3.00	13.40

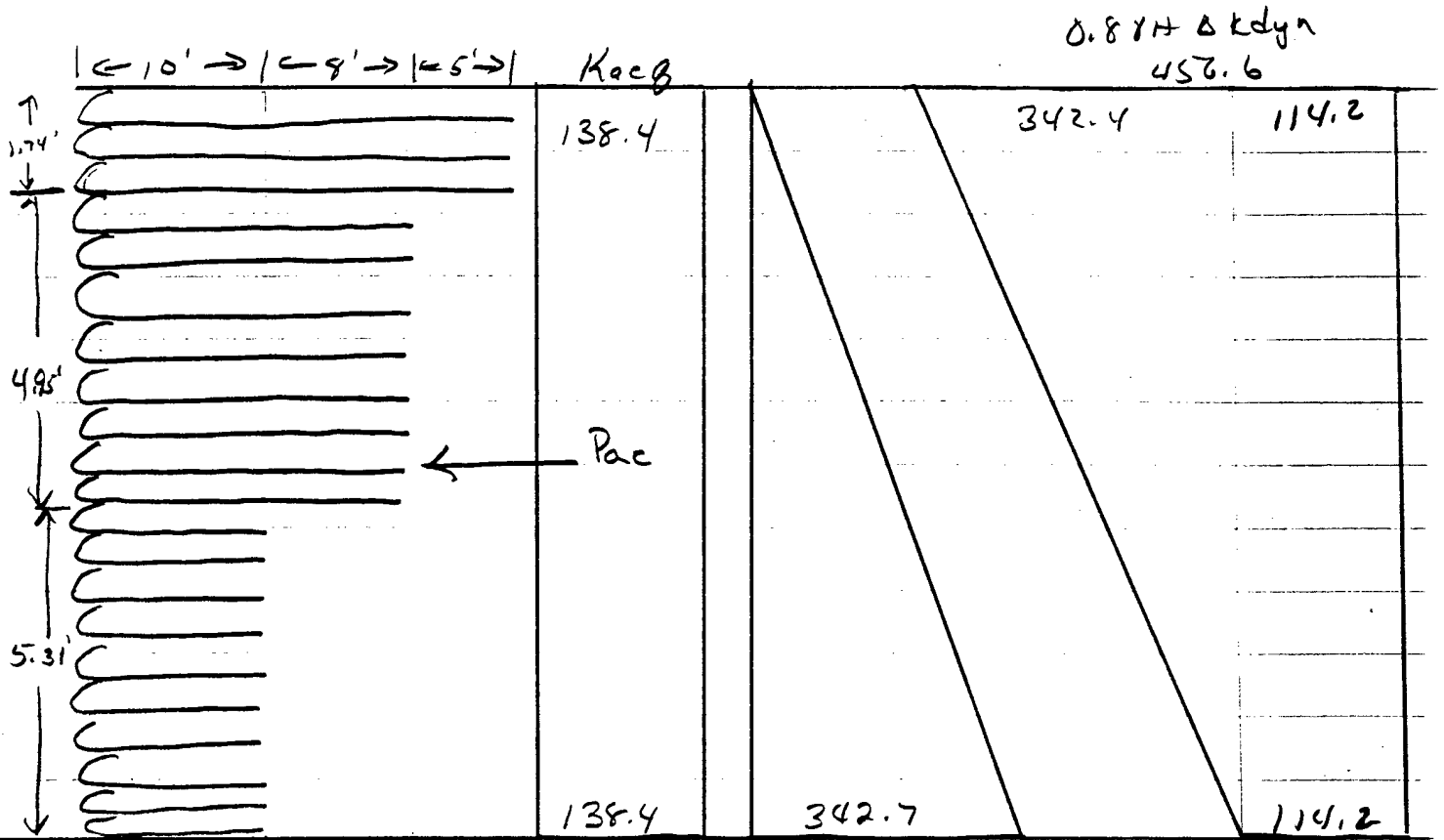

$$P_g = 138.4(12) = 1660.8$$

$$P_a = \frac{1}{2}(342.4)(12) = 2054.4$$

$$P_{dyn1} = \frac{1}{2}(342.4)(12) = 2054.4$$

$$P_{dyn2} = 114.2(12) = 1370.4$$

$$P_{ac} = 7141.8$$

0.28H Δkdyn

Ka γ H	0.28H Δkdyn
⊙ 1/2 H = 6	
⊙ 1/3 H = 4	
⊙ 1/3 H = 8	
⊙ 1/2 H = 6	
⊙ H = 6	

$$FSOT = \frac{\omega_1 \tau_1 + \omega_2 \tau_2 + \omega_3 \tau_3}{P_{ac}(\tau)} = \frac{1.74(23)(110)(11.5) + 4.95(15)(110)(9) + 5.31(10)(110)(5)}{7141.8(6)}$$

$$= 3.92 > 3 \quad \text{OK!}$$

Sliding

$$FSS = \frac{(c_u + \frac{w}{L} \tan \delta)}{P_{ac}} L = \frac{(320 + \frac{(1.74(23) + 4.95(18) + 5.31(10))}{10} 116 \tan 24)}{10} 10$$

7141.8

= 1.7 No good

Increase all layers to 24'

FS = 3.05 > 3 OK!

Layer No.	Depth z (ft)	Spacing Sv (ft)	Embedment Overlap		Cut Length Lc (ft)
			Length Lt (ft)	Length Lo (ft)	
21	0.58	0.58	24	3	27.58
20	1.16	0.58	24	3	27.58
19	1.74	0.58	24	3	27.58
18	2.32	0.58	24	3	27.58
17	2.90	0.58	24	3	27.58
16	3.48	0.58	24	3	27.58
15	4.06	0.58	24	3	27.58
14	4.64	0.58	24	3	27.58
13	5.22	0.58	24	3	27.58
12	5.80	0.58	24	3	27.58
11	6.38	0.58	24	3	27.58
10	6.96	0.58	24	3	27.58
9	7.54	0.58	24	3	27.58
8	8.12	0.58	24	3	27.58
7	8.70	0.58	24	3	27.58
6	9.28	0.58	24	3	27.58
5	9.86	0.58	24	3	27.58
4	10.44	0.58	24	3	27.58
1	11.02	0.58	24	3	27.58
Total Fabric Length per Linear foot of wall (ft/ft)					524.02

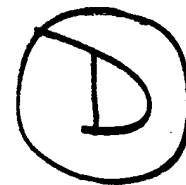

Rankine method

$$K_h = 0.4$$

$$P_{6ft} = 12.88 \text{ ft/sec}$$

$$k_p = 0.4$$

$$f = 40.7$$

$$K_{ac} = 0.5345$$

$$\Delta K_{dyn} = K_{ac} - K_a = 0.5345 - 0.2596$$
$$= 0.2749$$

$$\sigma_d = 106.9 + 28.6z + 30.2(9.6 - 0.6z)$$

$$S_v = \frac{484.85}{1.3 [106.9 + 28.6z + 30.2(9.6 - 0.6z)]}$$

Depth z (ft)	Sigma q (lb/ft <sup>2</sup> )	Sigma s (lb/ft <sup>2</sup> )	Delta Sigma dyn (lb/ft <sup>2</sup> )	SIGMA d (lb/ft <sup>2</sup> )	Sv Sv (ft)	Sv Use (ft)	Sv Use (inch)
0	106.90	0.0	290.3	397.2	0.94	0.667	8.0
1	106.90	28.6	272.2	407.6	0.91	0.667	8.0
2	106.90	57.1	254.0	418.0	0.89	0.667	8.0
3	106.90	85.7	235.9	428.4	0.87	0.667	8.0
4	106.90	114.2	217.7	438.8	0.85	0.667	8.0
5	106.90	142.8	199.6	449.3	0.83	0.667	8.0
6	106.90	171.3	181.4	459.7	0.81	0.667	8.0
7	106.90	199.9	163.3	470.1	0.79	0.667	8.0
8	106.90	228.4	145.1	480.5	0.78	0.667	8.0
9	106.90	257.0	127.0	490.9	0.76	0.667	8.0
10	106.90	285.6	108.9	501.3	0.74	0.667	8.0
11	106.90	314.1	90.7	511.7	0.73	0.667	8.0
12	106.90	342.7	72.6	522.1	0.71	0.667	8.0

## Fabric Length

$$L_R = (H - z) \tan(90 - \beta) = (12 - z) \tan(90 - 40.7)$$

$$L_c = \frac{S_v \sum d F S}{z(c + \gamma z \tan \beta)} = \frac{S_v [106.9 + 28.6z + 30.2(9.6 - 0.6z)]}{z(110) z(\tan 24)}$$

$$L_t = L_c + L_R$$

$$L_o = \frac{1}{2} L_c \geq 3.0'$$

$$L_c = L_t + L_o + S_v$$

Layer No.	Depth z (ft)	Spacing Sv (ft)	Nonresisting Length		Resisting Length		Total Embedment Length		Overlap Length		Cut Length Lc (ft)
			Lr (ft)	Le (calc) (ft)	Le (min) (ft)	Lt (calc) (ft)	Lt (use) (ft)	Lo (calc) (ft)	Lo (use) (ft)		
18	0.67	0.67	13.17	5.36	5.36	18.53	19.00	2.68	3.00	22.67	
17	1.34	0.67	12.39	2.73	3.00	15.39	19.00	1.36	3.00	22.67	
16	2.01	0.67	11.61	1.85	3.00	14.61	19.00	0.92	3.00	22.67	
15	2.68	0.67	10.84	1.41	3.00	13.84	19.00	0.70	3.00	22.67	
14	3.35	0.67	10.06	1.15	3.00	13.06	19.00	0.57	3.00	22.67	
13	4.02	0.67	9.28	0.97	3.00	12.28	19.00	0.49	3.00	22.67	
12	4.69	0.67	8.50	0.85	3.00	11.50	19.00	0.42	3.00	22.67	
11	5.36	0.67	7.72	0.75	3.00	10.72	19.00	0.38	3.00	22.67	
10	6.03	0.67	6.94	0.68	3.00	9.94	10.00	0.34	3.00	13.67	
9	6.70	0.67	6.16	0.62	3.00	9.16	10.00	0.31	3.00	13.67	
8	7.37	0.67	5.38	0.57	3.00	8.38	10.00	0.29	3.00	13.67	
7	8.04	0.67	4.60	0.53	3.00	7.60	10.00	0.27	3.00	13.67	
6	8.71	0.67	3.82	0.50	3.00	6.82	10.00	0.25	3.00	13.67	
5	9.38	0.67	3.05	0.47	3.00	6.05	10.00	0.23	3.00	13.67	
4	10.05	0.67	2.27	0.44	3.00	5.27	10.00	0.22	3.00	13.67	
3	10.72	0.67	1.49	0.42	3.00	4.49	10.00	0.21	3.00	13.67	
2	11.39	0.67	0.71	0.40	3.00	3.71	10.00	0.20	3.00	13.67	
1	12.00	0.67	0.00	0.39	3.00	3.00	10.00	0.19	3.00	13.67	

# External Stability

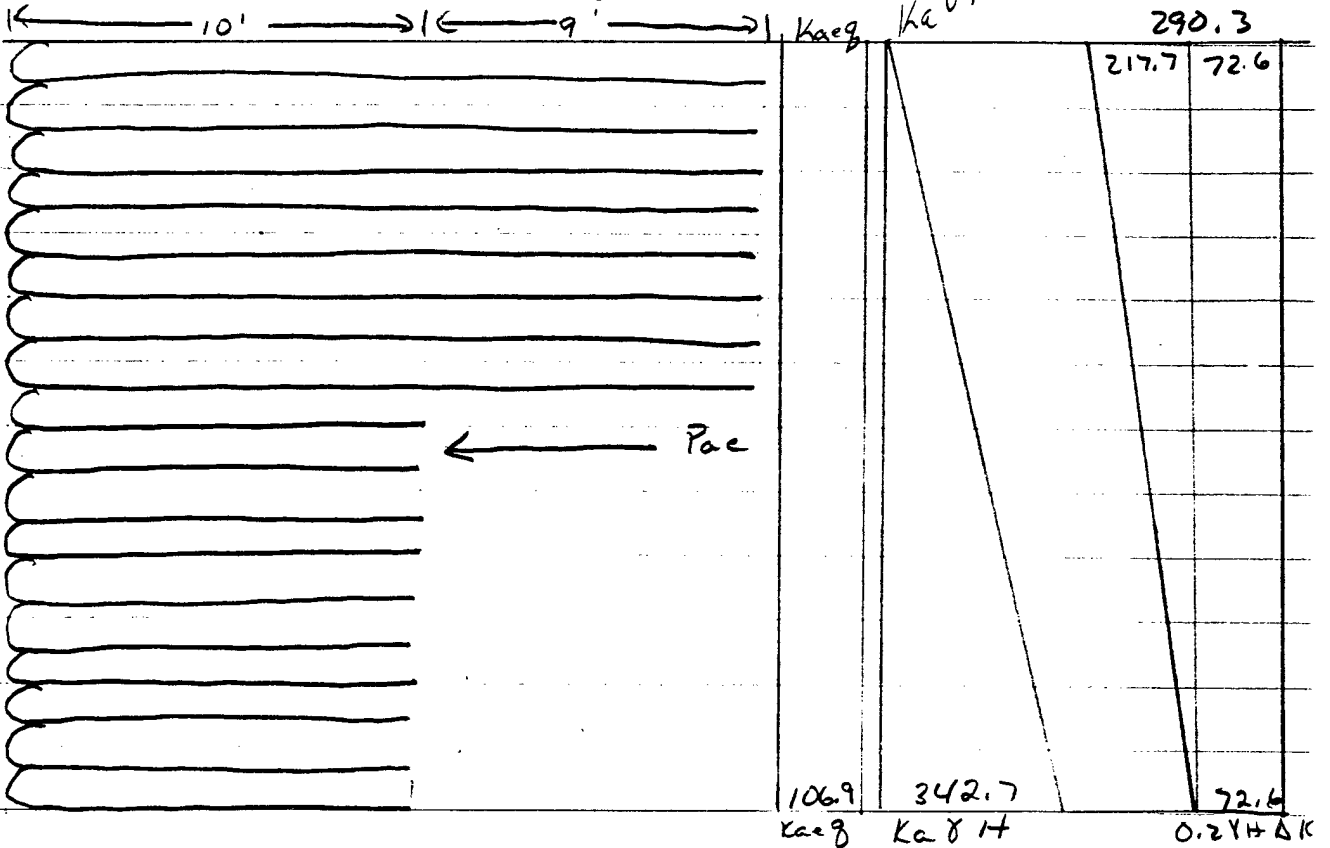

$$P_g = 106.9(12) = 1282.8$$

$$P_a = \frac{1}{2}(342.7)(12) = 2056.2$$

$$P_{dyn_1} = \frac{1}{2}(217.7)(12) = 1306.2$$

$$P_{dyn_2} = 72.6(12) = \underline{871.2}$$

$$P_{ae} = 5516.4$$

$$\textcircled{a} \quad 6'$$

$$\textcircled{a} \quad 4'$$

$$\textcircled{a} \quad 8'$$

$$\textcircled{a} \quad 6'$$

$$\textcircled{a} \quad h = 5.73'$$

## Overturning

$$FS_{OT} = \frac{W_1 \gamma_1 + W_2 \gamma_2}{P(h)} = \frac{[19(5.36) \frac{19}{2} + 10(6.64) \frac{16}{2}] 110}{5516.4 (5.73)} = 4.5 > 3 \quad \text{OK}$$



### Sliding

$$FS_s = \frac{(C_a + \frac{W}{L} \tan \delta) L}{Pore}$$

$$= \frac{(320 + \frac{[19(5.36) + 10(6.64)] 110 \tan 24}{10}) 10}{5516.4} = 2.07 < \text{NO GOOD}$$

increase all layers to 19'

$$FS_s = \frac{(320 + \frac{19(12)(110) \tan 24}{19}) 19}{5516.4} = 3.13 > 3 \text{ OK}$$

Final use 18 rows, spaced @ 8" and all rows 19' long

Layer No.	Depth z (ft)	Spacing Sv (ft)	Embedment Overlap		Cut Length Lc (ft)
			Length Lt (ft)	Length Lo (ft)	
18	0.67	0.67	19	3	22.67
17	1.34	0.67	19	3	22.67
16	2.01	0.67	19	3	22.67
15	2.68	0.67	19	3	22.67
14	3.35	0.67	19	3	22.67
13	4.02	0.67	19	3	22.67
12	4.69	0.67	19	3	22.67
11	5.36	0.67	19	3	22.67
10	6.03	0.67	19	3	22.67
9	6.70	0.67	19	3	22.67
8	7.37	0.67	19	3	22.67
7	8.04	0.67	19	3	22.67
6	8.71	0.67	19	3	22.67
5	9.38	0.67	19	3	22.67
4	10.05	0.67	19	3	22.67
3	10.72	0.67	19	3	22.67
2	11.39	0.67	19	3	22.67
1	12.00	0.67	19	3	22.67

Total Fabric Length per Linear foot of wall (ft/ft) 408.06

(D)

Rankine method  $K_a = 0.03$

$P_{6ft} = 9.66 \text{ ft/sec}^2$   $K_a = 0.03$   $\phi = 47.2^\circ$

$K_{ae} = \frac{-(35-30)(0.478-0.400)}{35-40} + 0.478 = 0.4624$  (Des p. 33)

$\Delta K_{dyn} = K_{ae} - K_a = 0.4624 - 0.2596 = 0.2028$

$\sigma_d = K_{ae} \gamma + K_a \gamma z + \Delta K_{dyn} \gamma (0.814 - 0.6z)$   
 $= 92.5 + 28.6z + 22.3(9.6 - 0.6z)$

$S_v = \frac{T_{allow}}{F_s \sigma_d} = \frac{484.85}{1.3 [92.5 + 28.6z + 22.3(9.6 - 0.6z)]}$

Depth z (ft)	Sigma q (lb/ft <sup>2</sup> )	Sigma s (lb/ft <sup>2</sup> )	Delta Sigma dyn (lb/ft <sup>2</sup> )	SIGMA d (lb/ft <sup>2</sup> )	Sv (ft)	Sv Use (ft)	Sv Use (inch)
0	92.48	0.0	214.2	306.6	1.22	1.000	12.0
1	92.48	28.6	200.8	321.8	1.16	1.000	12.0
2	92.48	57.1	187.4	337.0	1.11	1.000	12.0
3	92.48	85.7	174.0	352.2	1.06	1.000	12.0
4	92.48	114.2	160.6	367.3	1.02	1.000	12.0
5	92.48	142.8	147.2	382.5	0.98	0.750	9.0
6	92.48	171.3	133.8	397.7	0.94	0.750	9.0
7	92.48	199.9	120.5	412.8	0.90	0.750	9.0
8	92.48	228.4	107.1	428.0	0.87	0.750	9.0
9	92.48	257.0	93.7	443.2	0.84	0.750	9.0
10	92.48	285.6	80.3	458.3	0.81	0.750	9.0
11	92.48	314.1	66.9	473.5	0.79	0.750	9.0
12	92.48	342.7	53.5	488.7	0.76	0.750	9.0

## Fabric Length

$$L_r = (12 - z) \tan(90 - 47.2) = (12 - z) 0.9260$$

$$L_e = \frac{S_v F S D}{2(c + \gamma z \tan \phi)} = \frac{S_v(1.3) [92.5 + 28.6z + 22.3(9.6 - 0.6z)]}{2(110) \pm \tan 24}$$

$$L_t = L_r + L_e$$

$$L_o = \frac{1}{2} L_e \geq 3' = \frac{S_v(1.3) [92.5 + 28.6z + 22.3(9.6 - 0.6z)]}{4(110) \pm \tan 24}$$

$$L_c = L_t + L_o + S_v$$

Layer No.	Depth z (ft)	Spacing Sv (ft)	Nonresisting Length	Resisting Length		Total Embedment Length		Overlap Length		Cut Length
			Lr (ft)	Le (calc) (ft)	Le (min) (ft)	Lt (use) (ft)	Lo (calc) (ft)	Lo (use) (ft)	Lc (ft)	
15	1.00	1.00	10.19	5.41	5.41	15.59	16.00	2.70	3.00	20.00
14	2.00	1.00	9.26	2.77	3.00	12.26	16.00	1.39	3.00	20.00
13	3.00	1.00	8.33	1.89	3.00	11.33	16.00	0.95	3.00	20.00
12	4.00	1.00	7.41	1.46	3.00	10.41	16.00	0.73	3.00	20.00
11	4.75	0.75	6.71	0.94	3.00	9.71	16.00	0.47	3.00	19.75
10	5.50	0.75	6.02	0.82	3.00	9.02	16.00	0.41	3.00	19.75
9	6.25	0.75	5.32	0.74	3.00	8.32	16.00	0.37	3.00	19.75
8	7.00	0.75	4.63	0.67	3.00	7.63	8.00	0.33	3.00	11.75
7	7.75	0.75	3.94	0.61	3.00	6.94	8.00	0.31	3.00	11.75
6	8.50	0.75	3.24	0.57	3.00	6.24	8.00	0.28	3.00	11.75
5	9.25	0.75	2.55	0.53	3.00	5.55	8.00	0.27	3.00	11.75
4	10.00	0.75	1.85	0.50	3.00	4.85	8.00	0.25	3.00	11.75
3	10.75	0.75	1.16	0.47	3.00	4.16	8.00	0.24	3.00	11.75
2	11.50	0.75	0.46	0.45	3.00	3.46	8.00	0.22	3.00	11.75
1	12.00	0.50	0.00	0.29	3.00	3.00	8.00	0.14	3.00	11.50

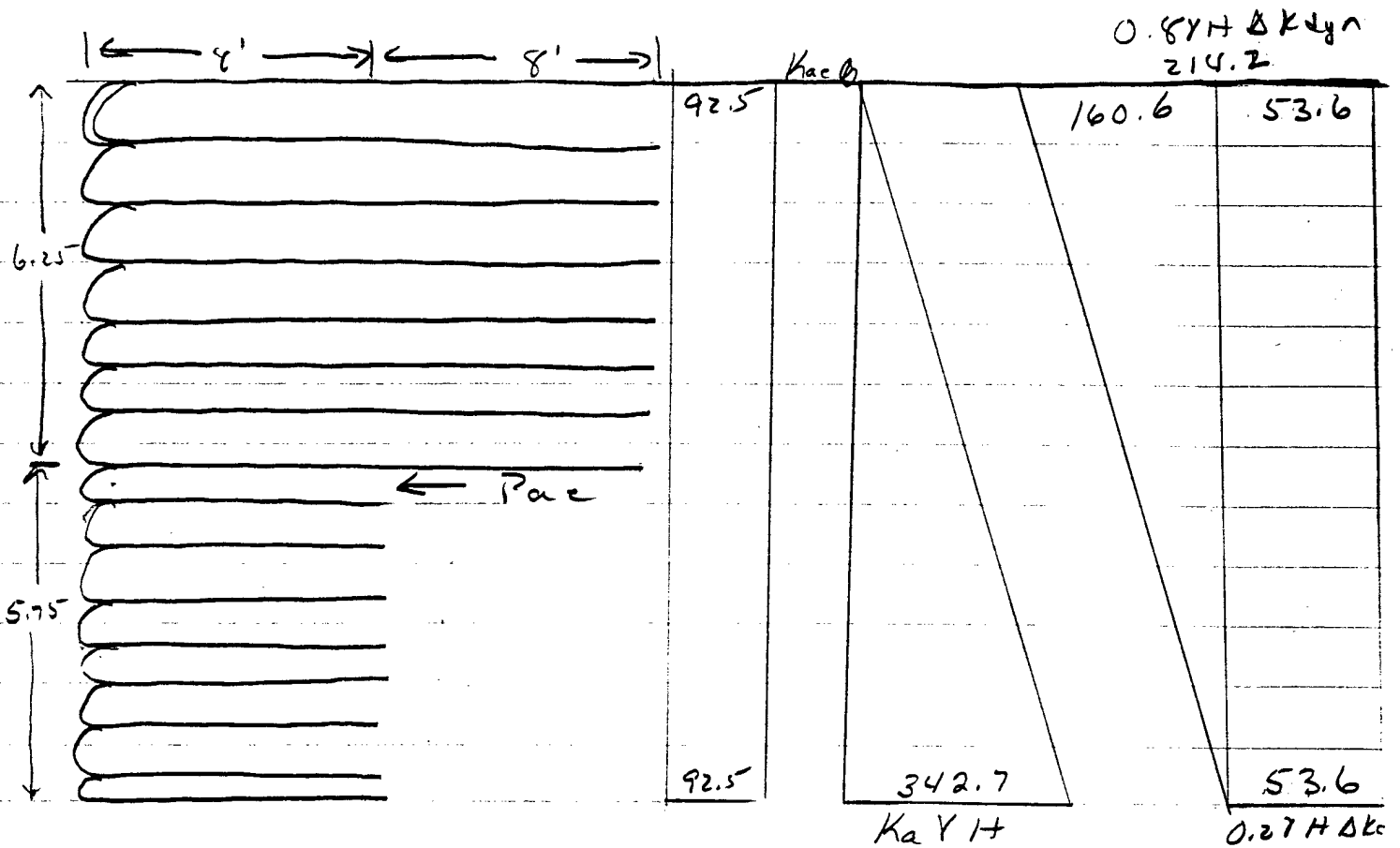

$$\begin{aligned}
 P_B &= 92.5(12) = 1110 & \text{(a) } \frac{1}{2}H &= 6 \\
 P_a &= \frac{1}{2}(342.7)(12) = 2056.2 & \text{(a) } \frac{1}{3}H &= 4 \\
 P_{dyn_1} &= \frac{1}{2}(160.6)(12) = 963.6 & \text{(a) } \frac{2}{3}H &= 8 \\
 P_{dyn_2} &= 53.6(12) = 643.2 & \text{(a) } \frac{1}{2}H &= 6 \\
 P_{ac} &= 4773.0 & \text{(a) } r &= 5.54'
 \end{aligned}$$

overturning

$$F_{SOT} = \frac{w_1 x_1 + w_2 x_2}{P(h)} = \frac{6.25(10)(110)(8) + 5.75(8)(110)(4)}{4773(5.54)} = \frac{410}{>3} > 3 \text{ OK}$$

## Sliding

$$FS_s = \frac{(C_u + \frac{W}{L} \tan 24)}{P_{ac}} L$$

$$= \frac{\left[ 320 + \frac{(6.25(16)110 + 5.75(8)110)}{8} \tan 24 \right] 8}{4773.0} = 2.03 \text{ No Good}$$

increase all layers to 16'

$$FS_s = \frac{\left( 320 + \frac{(16 \times 12 \times 110)}{16} \tan 24 \right) 16}{4773.0} = 3.04 > 3.0 \text{ OK!}$$

Final use 15 rows, all 16' long with spacing as follows: TOP 4 -  $S_v = 12''$

Layer No.	Depth z (ft)	Spacing Sv (ft)	Embedment, Overlap		Cut Length Lc (ft)
			Length Lt (ft)	Length Lo (ft)	
15	1.00	1.00	16	3	20.00
14	2.00	1.00	16	3	20.00
13	3.00	1.00	16	3	20.00
12	4.00	1.00	16	3	20.00
11	4.75	0.75	16	3	19.75
10	5.50	0.75	16	3	19.75
9	6.25	0.75	16	3	19.75
8	7.00	0.75	16	3	19.75
7	7.75	0.75	16	3	19.75
6	8.50	0.75	16	3	19.75
5	9.25	0.75	16	3	19.75
4	10.00	0.75	16	3	19.75
3	10.75	0.75	16	3	19.75
2	11.50	0.75	16	3	19.75
1	12.00	0.50	16	3	19.50

Total Fabric Length per Linear foot of wall (ft/ft) 297.00

(D)

Rankine Method

$$PGA = 6.44 \text{ ft/sec}^2$$

$$k_H = 0.2$$

$$k_H = 0.2 \quad f = 52.8^\circ$$

$$K_{ac} = \frac{-(35-36)(0.396-0.38z)}{(35-40)} + 0.396 = 0.3932$$

$$\Delta K_{dyn} = K_{ac} - K_a = 0.3932 - 0.2596 = 0.1336$$

$$\begin{aligned} T_d &= 6.3932(200) + 0.2596(110)z + 0.1336(0.8H - 0.6z)(110) \\ &= 78.6 + 28.6z + 14.7(9.6 - 0.6z) \end{aligned}$$

$$S_v = \frac{484.85}{1.3[78.6 + 28.6z + 14.7(9.6 - 0.6z)]}$$

Depth z (ft)	Sigma q (lb/ft <sup>2</sup> )	Sigma s (lb/ft <sup>2</sup> )	Delta Sigma dyn (lb/ft <sup>2</sup> )	SIGMA d (lb/ft <sup>2</sup> )	Sv (ft)	Sv Use (ft)	Sv Use (inch)
0	78.64	0.0	141.1	219.7	1.70	1.500	18.0
1	78.64	28.6	132.3	239.5	1.56	1.500	18.0
2	78.64	57.1	123.4	259.2	1.44	1.000	12.0
3	78.64	85.7	114.6	278.9	1.34	1.000	12.0
4	78.64	114.2	105.8	298.7	1.25	1.000	12.0
5	78.64	142.8	97.0	318.4	1.17	1.000	12.0
6	78.64	171.3	88.2	338.2	1.10	1.000	12.0
7	78.64	199.9	79.4	357.9	1.04	1.000	12.0
8	78.64	228.4	70.5	377.6	0.99	0.750	9.0
9	78.64	257.0	61.7	397.4	0.94	0.750	9.0
10	78.64	285.6	52.9	417.1	0.89	0.750	9.0
11	78.64	314.1	44.1	436.8	0.85	0.750	9.0
12	78.64	342.7	35.3	456.6	0.82	0.750	9.0

Fabric Length

$$L_r = (12 - z) \tan(90 - 52.8) = (12 - z) 0.7590$$

$$L_e = \frac{S_v \sigma_d FS}{2(c + \gamma z + \gamma_s)} = \frac{S_v (1.3) [78.6 + 28.6 z + 14.7(9.6 - 0.6z)]}{2(110)(z) \tan 24}$$

$$L_t = L_e + L_r$$

$$L_o = \frac{1}{2} L_e \geq 3.0'$$

$$L_c = L_t + L_o + S_v$$

Layer No.	Depth z (ft)	Spacing Sv (ft)	Nonresisting	Resisting Length		Total Embedment Length		Overlap Length		Cut Length
			Lr (ft)	Le (calc) (ft)	Le (min) (ft)	Lt (calc) (ft)	Lt (use) (ft)	Lo (calc) (ft)	Lo (use) (ft)	Lc (ft)
13	1.50	1.50	7.97	5.48	5.48	13.45	14.00	2.74	3.00	18.50
12	2.50	1.00	7.21	2.25	3.00	10.21	14.00	1.12	3.00	18.00
11	3.50	1.00	6.45	1.64	3.00	9.45	14.00	0.82	3.00	18.00
10	4.50	1.00	5.69	1.31	3.00	8.69	14.00	0.65	3.00	18.00
9	5.50	1.00	4.93	1.10	3.00	7.93	14.00	0.55	3.00	18.00
8	6.50	1.00	4.17	0.95	3.00	7.17	14.00	0.47	3.00	18.00
7	7.50	1.00	3.42	0.84	3.00	6.42	7.00	0.42	3.00	11.00
6	8.25	0.75	2.85	0.58	3.00	5.85	7.00	0.29	3.00	10.75
5	9.00	0.75	2.28	0.54	3.00	5.28	7.00	0.27	3.00	10.75
4	9.75	0.75	1.71	0.51	3.00	4.71	7.00	0.25	3.00	10.75
3	10.50	0.75	1.14	0.48	3.00	4.14	7.00	0.24	3.00	10.75
2	11.25	0.75	0.57	0.46	3.00	3.57	7.00	0.23	3.00	10.75
1	12.00	0.75	0.00	0.43	3.00	3.00	7.00	0.22	3.00	10.75

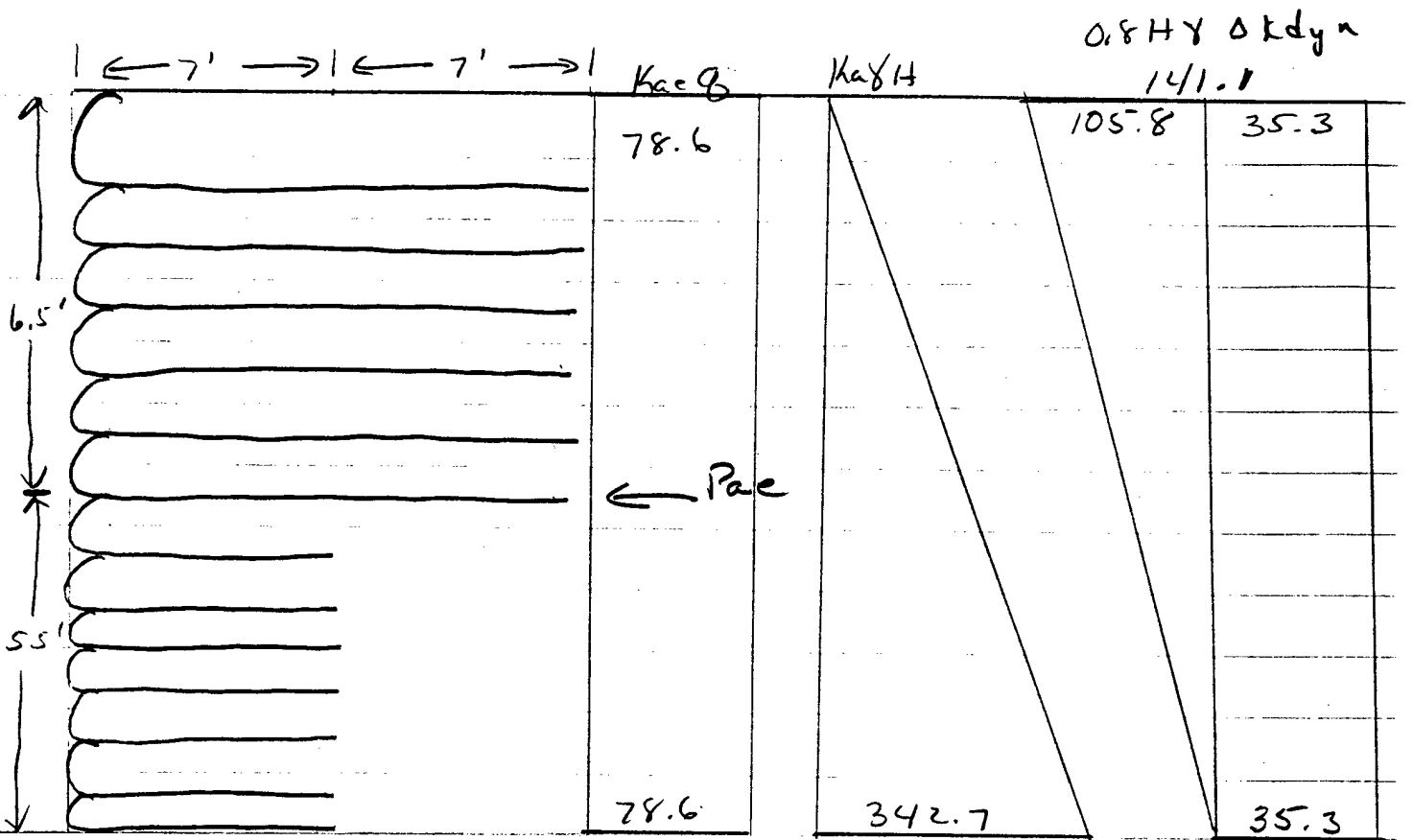

$$P_g = 78.6(12) = 943.2$$

$$P_a = \frac{1}{2}(342.7)(12) = 2056.2$$

$$P_{dyn_1} = \frac{1}{2}(105.8)(12) = 634.8$$

$$P_{dyn_2} = 35.3(12) = 423.6$$

$$P_{ac} = 4057.8$$

$$\textcircled{a} \quad \frac{1}{2} H = 6$$

$$\textcircled{a} \quad \frac{1}{3} H = 4$$

$$\textcircled{a} \quad \frac{2}{3} H = 8$$

$$\textcircled{a} \quad \frac{1}{2} H = 6$$

$$\textcircled{a} \quad h = 5.30'$$

0.2 HY  $\Delta k_d$

$$FSOT = \frac{W_1 V_1 + W_2 V_2}{P(h)} = \frac{14(6.5)(110)(7) + 7(5.5)(110)(3.5)}{4057.8(5.30)} = 3.94 \quad \text{OK}$$



Sliding

$$FS_s = \left( \frac{320 + \frac{14(6.5) + 7(5.5)}{7} \cdot 110 \tan 24}{4057.8} \right) 7 = 2.11 \text{ NO GOOD!}$$

Increase all rows to 14'

$$FS_s = \left( \frac{320 + \frac{14(12)(110) \tan 24}{14}}{4057.8} \right) 14 = 3.13 \text{ OK!}$$

Final

use 13 rows, all 14' long with the following spacing:

Row	Spacing
1	1.5'
2-7	1.0'
8-13	0.75'

Layer No.	Depth z (ft)	Spacing Sv (ft)	Embedment		Cut Length Lc (ft)
			Length Lt (ft)	Overlap Length Lo (ft)	
13	1.50	1.50	14	3	18.50
12	2.50	1.00	14	3	18.00
11	3.50	1.00	14	3	18.00
10	4.50	1.00	14	3	18.00
9	5.50	1.00	14	3	18.00
8	6.50	1.00	14	3	18.00
7	7.50	1.00	14	3	18.00
6	8.25	0.75	14	3	17.75
5	9.00	0.75	14	3	17.75
4	9.75	0.75	14	3	17.75
3	10.50	0.75	14	3	17.75
2	11.25	0.75	14	3	17.75
1	12.00	0.75	14	3	17.75
Total Fabric Length per Linear foot of wall (ft/ft)					233.00

(D)

Rankine method

$$P_{6A} = 3.22 \text{ ft/sec}^2$$

$$K_H = 0.1$$

$$K_R = 0.1 \quad f = 58.3^\circ$$

$$K_{ac} = \frac{-(35-24)(0.328-0.268)}{35-40} + 0.328 = 0.3160$$

$$\Delta K_{dyn} = K_{ac} - K_a = 0.3160 - 0.2596 = 0.0564$$

$$\begin{aligned} \Delta d &= 0.3160(200) + 0.2596(110)z + 0.0564(110)(9.6 - 0.6z) \\ &= 63.2 + 28.6z + 6.2(9.6 - 0.6z) \end{aligned}$$

$$S_v = \frac{484.85}{1.3(63.2 + 28.6z + 6.2(9.6 - 0.6z))}$$

Depth z (ft)	Sigma q (lb/ft <sup>2</sup> )	Sigma s (lb/ft <sup>2</sup> )	Delta Sigma dyn (lb/ft <sup>2</sup> )	SIGMA d (lb/ft <sup>2</sup> )	Sv Sv (ft)	Sv Use (ft)	Sv Use (inch)
0	63.20	0.0	59.6	122.8	3.04	2.000	24.0
1	63.20	28.6	55.8	147.6	2.53	2.000	24.0
2	63.20	57.1	52.1	172.4	2.16	2.000	24.0
3	63.20	85.7	48.4	197.3	1.89	1.500	18.0
4	63.20	114.2	44.7	222.1	1.68	1.500	18.0
5	63.20	142.8	40.9	246.9	1.51	1.500	18.0
6	63.20	171.3	37.2	271.8	1.37	1.000	12.0
7	63.20	199.9	33.5	296.6	1.26	1.000	12.0
8	63.20	228.4	29.8	321.4	1.16	1.000	12.0
9	63.20	257.0	26.1	346.3	1.08	1.000	12.0
10	63.20	285.6	22.3	371.1	1.01	0.750	9.0
11	63.20	314.1	18.6	395.9	0.94	0.750	9.0
12	63.20	342.7	14.9	420.8	0.89	0.750	9.0

Fabric Length

$$L_R = (z - z_0) \cdot 0.6176$$

$$L_e = \frac{S_v \cdot \text{DFS}}{z(c + \gamma z + s)} = \frac{S_v(1.3) [63.2 + 28.6z + 6.2(9.6 - 0.6z)]}{2(110)(z) \tan 24}$$

$$L_0 = \frac{1}{2} L_e \geq 3.0'$$

$$L_t = L_e + L_R$$

$$L_c = L_t + L_0 + S_v$$

Layer No.	Depth z (ft)	Spacing Sv (ft)	Nonresisting	Resisting Length		Total Embedment Length		Overlap Length		Cut Length
			Lr (ft)	Le (calc) (ft)	Le (min) (ft)	Lt (calc) (ft)	Lt (use) (ft)	Lo (calc) (ft)	Lo (use) (ft)	Lc (ft)
11	2.00	2.00	6.18	5.54	5.54	11.72	12.00	2.77	3.00	17.00
10	3.50	1.50	5.25	2.47	3.00	8.25	12.00	1.23	3.00	16.50
9	5.00	1.50	4.32	1.79	3.00	7.32	12.00	0.89	3.00	16.50
8	6.00	1.00	3.71	1.02	3.00	6.71	12.00	0.51	3.00	16.00
7	7.00	1.00	3.09	0.89	3.00	6.09	12.00	0.45	3.00	16.00
6	8.00	1.00	2.47	0.80	3.00	5.47	6.00	0.40	3.00	10.00
5	9.00	1.00	1.85	0.72	3.00	4.85	6.00	0.36	3.00	10.00
4	9.75	0.75	1.39	0.51	3.00	4.39	6.00	0.25	3.00	9.75
3	10.50	0.75	0.93	0.48	3.00	3.93	6.00	0.24	3.00	9.75
2	11.25	0.75	0.46	0.46	3.00	3.46	6.00	0.23	3.00	9.75
1	12.00	0.75	0.00	0.43	3.00	3.00	6.00	0.22	3.00	9.75

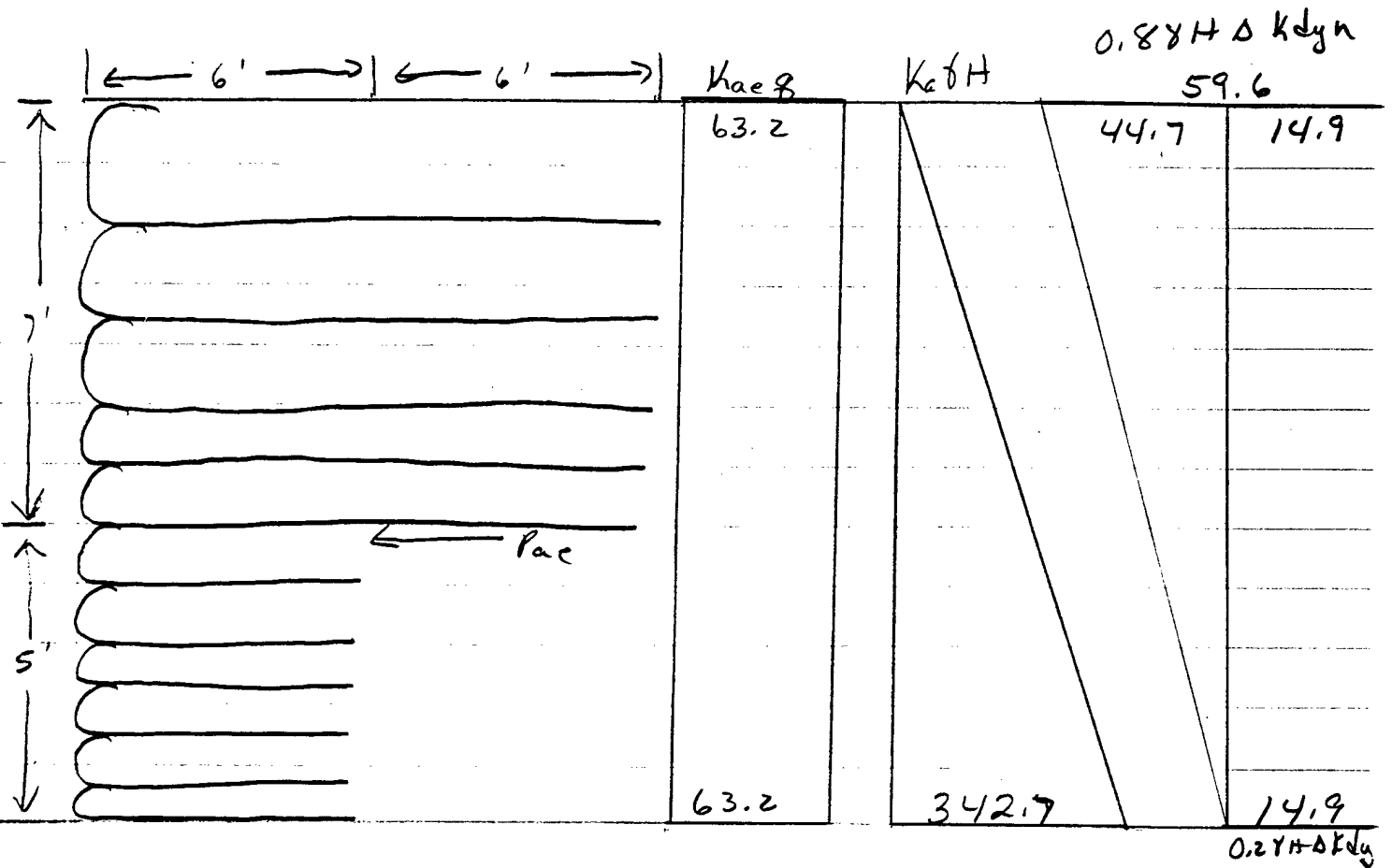

$$P_g = 63.2(12) = 758.4$$

$$P_a = \frac{1}{2}(342.7)(12) = 2056.2$$

$$P_{dyn_1} = \frac{1}{2}(44.7)(12) = 268.2$$

$$P_{dyn_2} = 14.9(12) = 178.8$$

$$P_{ac} = 3261.6$$

$$\textcircled{a} \quad \frac{1}{2}H = 6$$

$$\textcircled{a} \quad \frac{1}{3}H = 4$$

$$\textcircled{a} \quad \frac{2}{3}H = 8$$

$$\textcircled{a} \quad \frac{1}{2}H = 6$$

$$\textcircled{a} \quad h = 4.90'$$

$$FSOT = \frac{W_1 V_1 + W_2 V_2}{P(h)} = \frac{7(12)(110)6 + 5(6)(110)(3)}{3261.6(4.9)} = 4.09 > 3 \quad \text{OK!}$$

Sliding

$$FS_s = \frac{320 + \frac{[7(12)(110) + 5(6)(110)] \tan 24}{6}}{3261.6} = 2.3 \text{ NO good!}$$

increase Bottom rows to 10'

$$FS_s = \frac{320 + \frac{7(12)(110) + 5(10)(110) \tan 24}{10}}{3261.6} = 2.99 \approx 3.0 \text{ OK!}$$

make 11 rows, top 5 rows to be 12' long  
 Bottom 7 rows to be 10' long

Spaced as follows:

ROW	Spacing
1	2'
2-3	1.5'
4-7	1.0'
8-13	0.75'

Layer No.	Depth z (ft)	Spacing Sv (ft)	Embedment Overlap		Cut Length Lc (ft)
			Length Lt (ft)	Length Lo (ft)	
11	2.00	2.00	12	3	17.00
10	3.50	1.50	12	3	16.50
9	5.00	1.50	12	3	16.50
8	6.00	1.00	12	3	16.00
7	7.00	1.00	12	3	16.00
6	8.00	1.00	10	3	14.00
5	9.00	1.00	10	3	14.00
4	9.75	0.75	10	3	13.75
3	10.50	0.75	10	3	13.75
2	11.25	0.75	10	3	13.75
1	12.00	0.75	10	3	13.75
<b>Total Fabric Length per Linear foot of wall (ft/ft)</b>					<b>165.00</b>

(D)

Rankine Method,  $K_R = 0.00$  (Static)

$$P/A = 0 \quad K_R = 0 \quad \phi = 63^\circ$$

$$K_{ac} = 0.2596, \quad K_a = 0.2596 \quad \Delta K_{dyn} = 0$$

$$\begin{aligned} \sigma_d &= K_{ac} \gamma + K_a \gamma z \\ &= 0.2596(200) + 0.2596(110)z \\ &= 51.9 + 28.6z \end{aligned}$$

$$S_v = \frac{484.85}{1.3(51.9 + 28.6z)}$$

Depth z (ft)	Sigma q (lb/ft <sup>2</sup> )	Sigma s (lb/ft <sup>2</sup> )	Delta Sigma dyn (lb/ft <sup>2</sup> )	SIGMA d (lb/ft <sup>2</sup> )	Sv Use (ft)	Sv Use (inch)
0	51.92	0.0	0.0	51.9	7.18	24.0
1	51.92	28.6	0.0	80.5	4.63	24.0
2	51.92	57.1	0.0	109.0	3.42	24.0
3	51.92	85.7	0.0	137.6	2.71	24.0
4	51.92	114.2	0.0	166.1	2.24	24.0
5	51.92	142.8	0.0	194.7	1.92	18.0
6	51.92	171.3	0.0	223.3	1.67	18.0
7	51.92	199.9	0.0	251.8	1.48	18.0
8	51.92	228.4	0.0	280.4	1.33	12.0
9	51.92	257.0	0.0	308.9	1.21	12.0
10	51.92	285.6	0.0	337.5	1.11	12.0
11	51.92	314.1	0.0	366.0	1.02	12.0
12	51.92	342.7	0.0	394.6	0.95	12.0

## Fabric Length

$$L_R = (12 - z) \cdot 0.5095$$

$$L_e = \frac{S_v \cdot \sigma_d \cdot FS}{2(c + \gamma z + \tan \delta)} = \frac{S_v (51.9 + 28.6 z)}{2(110)(z) (\tan 2\gamma)}$$

$$L_o = \frac{1}{2} L_e = \frac{S_v (51.9 + 28.6 z)}{4(110)(z) (\tan 2\gamma)}$$

$$L_t = L_e + L_R$$

$$L_{cut} = L_t + L_o + S_v$$

Layer No.	Depth z (ft)	Spacing Sv (ft)	Nonresisting Length	Resisting Length		Total Embedment Length		Overlap Length		Cut Length
			Lr (ft)	Le (calc) (ft)	Le (min) (ft)	Lt (calc) (ft)	Lt (use) (ft)	Lo (calc) (ft)	Lo (use) (ft)	Lc (ft)
9	2.00	2.00	5.10	5.54	5.54	10.64	11.00	2.77	3.00	16.00
8	4.00	2.00	4.08	2.91	3.00	7.08	11.00	1.46	3.00	16.00
7	5.50	1.50	3.31	1.64	3.00	6.31	11.00	0.82	3.00	15.50
6	7.00	1.50	2.55	1.34	3.00	5.55	11.00	0.67	3.00	15.50
5	8.00	1.00	2.04	0.80	3.00	5.04	5.00	0.40	3.00	9.00
4	9.00	1.00	1.53	0.72	3.00	4.53	5.00	0.36	3.00	9.00
3	10.00	1.00	1.02	0.67	3.00	4.02	5.00	0.33	3.00	9.00
2	11.00	1.00	0.51	0.62	3.00	3.51	5.00	0.31	3.00	9.00
1	12.00	1.00	0.00	0.58	3.00	3.00	5.00	0.29	3.00	9.00

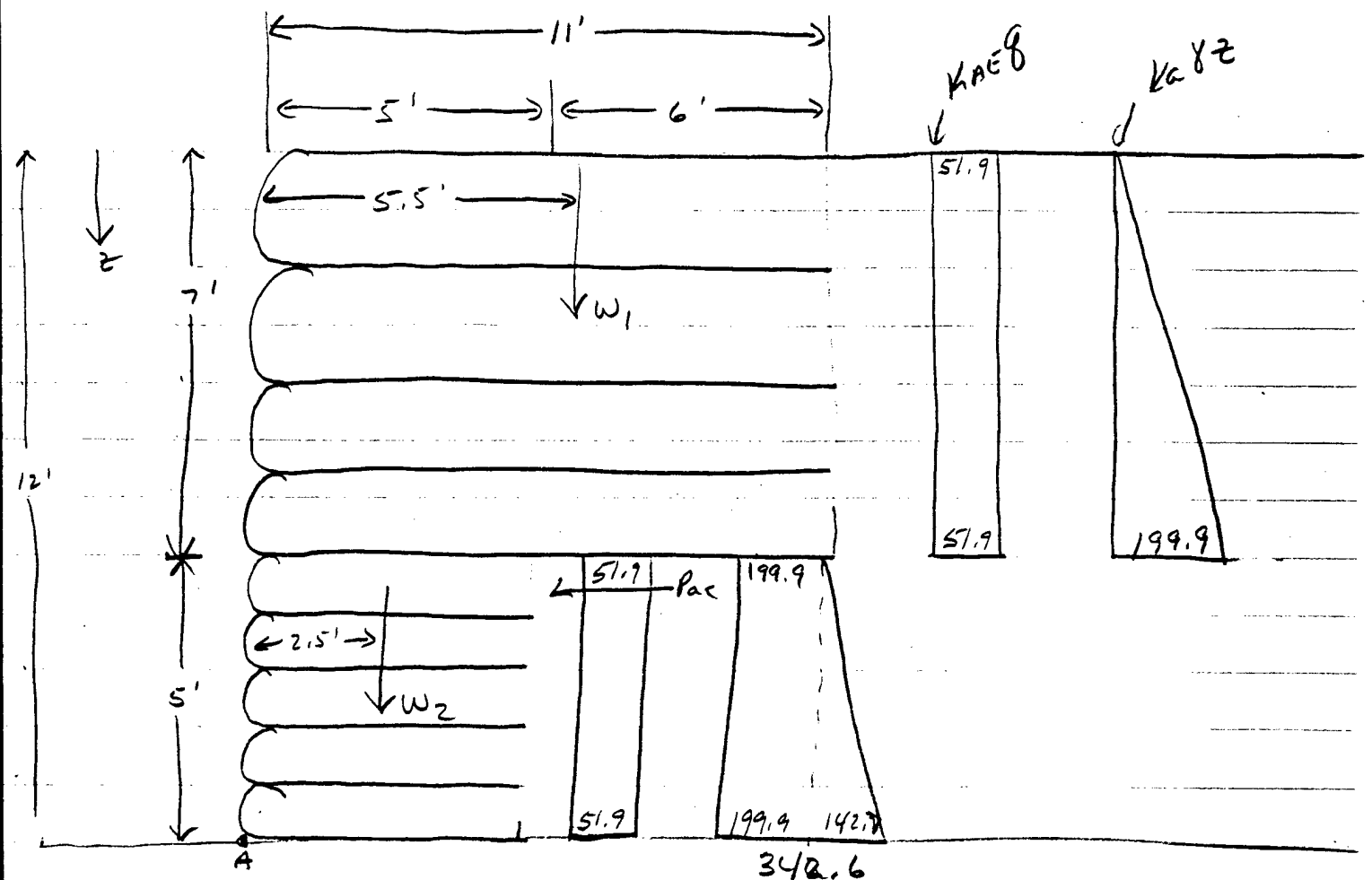

$$P_g = 51.9 (12) = 622.8 \quad @ \quad \frac{1}{2} z = 6'$$

$$P_a = \frac{1}{2} 342.6 (12) = 2055.6 \quad @ \quad \frac{2}{3} z = 8'$$

$$P = P_g + P_a = 622.8 + 2055.6 = 2678.4 \quad @$$

$$\bar{h} = \frac{622.8(6) + 2055.6(4)}{2678.4} = 4.47'$$

Overturning about pt A

$$\bar{S}_{OT} = \frac{W_1(5.5) + W_2(2.5)}{P \bar{h}} = \frac{11(7)(110)(5.5) + 5(5)(110)(2.5)}{2678.4(4.47)} = 4.47$$

> 3  
OK



Sliding

$$FS_s = \frac{(C_a + \frac{w}{L} \tan \phi)}{P} L = \frac{(320 + \frac{7(11)(110) + (5)5(110)}{5} \tan 24)}{2678.4} \cdot 5 = 2.4$$

OK  
NOgc

Increase bottom 5 layers to 8'

$$FS_s = \frac{(320 + \frac{7(11)(110) + 5(8)(114)}{8} \tan 24)}{2678.4} \cdot 8 = 3.10 > 3 \text{ OK}$$

use 9 rows as follows

- top 2 -  $S_v = 2.0'$        $L = 11'$
- next 2 -  $S_v = 1.5'$        $L = 11'$
- Bottom 4 -  $S_v = 1.0'$        $L = 8'$

Layer No.	Depth z (ft)	Spacing Sv (ft)	Embedment		Cut Length Lc (ft)
			Length Lt (ft)	Overlap Length Lo (ft)	
9	2.00	2.00	11	3	16.00
8	4.00	2.00	11	3	16.00
7	5.50	1.50	11	3	15.50
6	7.00	1.50	11	3	15.50
5	8.00	1.00	11	3	15.00
4	9.00	1.00	8	3	12.00
3	10.00	1.00	8	3	12.00
2	11.00	1.00	8	3	12.00
1	12.00	1.00	8	3	12.00
<b>Total Fabric Length per Linear foot of wall (ft/ft)</b>					<b>126.00</b>

## APPENDIX E

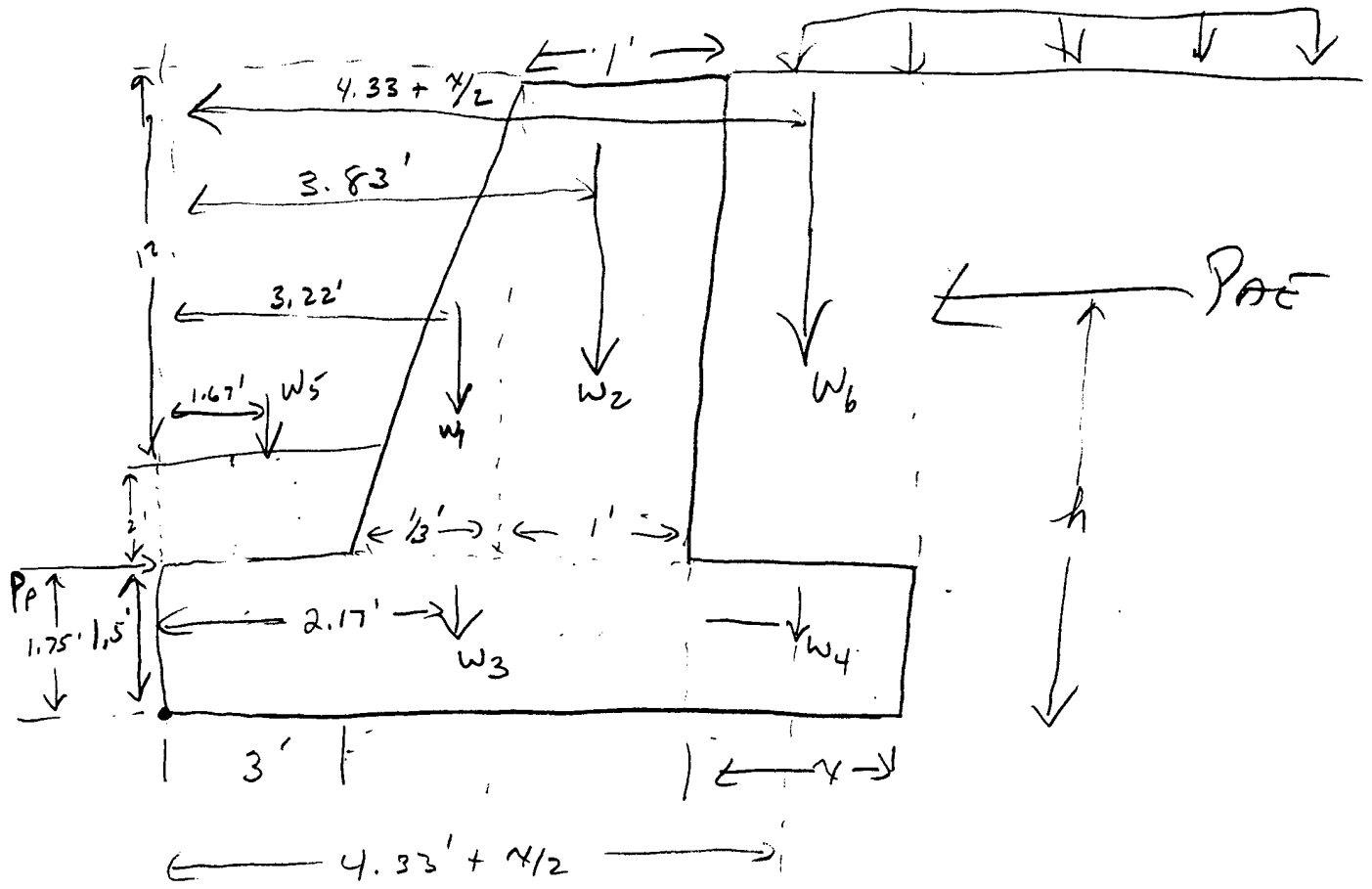

$$\begin{aligned}
 w_1 &= \frac{1}{2} \left( \frac{1}{3} \right) 14 (150) = 350 \text{ lb/ft} \\
 w_2 &= 1 (14) (150) = 2100 \text{ lb/ft} \\
 w_3 &= 1.5 (3 + 1.67) 150 = 1057 \text{ lb/ft} \\
 w_4 &= 1.5 \cdot 4 (150) = 225 \cdot 4 \text{ lb/ft} \\
 w_5 &= 110 (3) (2) = 660 \text{ lb/ft} \\
 w_6 &= 14 (4) (11) = 1540 \cdot 4 \text{ lb/ft}
 \end{aligned}$$

$$F_{SOT} = \frac{w_1 (3.22) + w_2 (3.83) + w_3 (2.17) + w_4 \left( 4.33 + \frac{x}{2} \right) + w_5 (1.67) + w_6 \left( 4.33 + \frac{x}{2} \right)}{P_{AE} (h)}$$

neglect effect of  $P_p$  for seismic Analysis

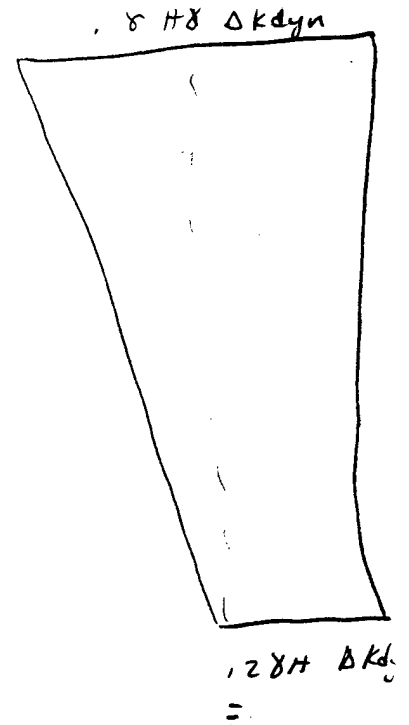
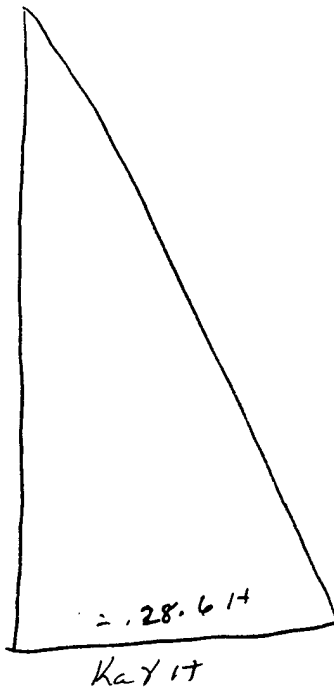
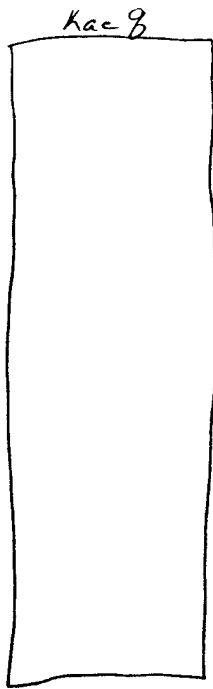

$K_h = 0.5$        $K_a = 0.2596$   
 $K_{ac} = 0.6920$        $\Delta K_{dyn} = 0.4324$

$P_g = 138.4(15.5) = 2145.2$   
 $P_a = 28.6(15.5)^2 / 2 = 3435.6$   
 $1364 P_{dyn1} = \frac{1}{2}(447.3)(15.5) = 3466.6$   
 $341 P_{dyn2} = 147.4(15.5) = 2284.7$   
 $P_{AE} = 11332.1$

①  $15.5/2 = 7.25'$   
 ②  $15.5/3 = 5.17'$   
 ③  $\frac{2}{3} \times 15.5 = 10.3'$   
 ④  $15.5/2 = 7.75'$   
 $h = 7.8'$

$K_h = 0.4$        $K_{ac} = 0.5345$        $\Delta K_{dyn} = 0.2749$

$P_g = 106.9(15.5) = 1657.0$   
 $P_a = 3435.6 = 3435.6$   
 $P_{dyn1} = \frac{1}{2}(281.3)(15.5) = 2180.1$   
 $P_{dyn2} = 93.7(15.5) = 1452.4$   
 $8725.0$

$h = 7.4$

$K_h = 0.3$        $K_{ac} = 0.4624$        $\Delta K_{dyn} = 0.2028$

$P_g = 92.5(15.5) = 1433.8$   
 $P_a = 3435.6 = 3435.6$   
 $P_{dyn1} = \frac{1}{2}(207.9)(15.5) = 1607.4$   
 $P_{dyn2} = 69.2(15.5) = 1072.6$   
 $7549.3$

$h = 7.1$

$$k_h = 0.2 \quad K_{ac} = 0.3932 \quad \Delta K_{dyn} = 0.1336$$

$$P_g = 78.6(15.5) = 1218.3$$

$$P_a = 3435.6 = 3435.6$$

$$P_{dyn1} = \frac{1}{2}(136.4)(15.5) = 1058.7$$

$$P_{dyn2} = 45.6(15.5) = 706.8$$

---

$$6419.3$$

$$h = 6.8$$

---

$$k_h = 0.1 \quad K_{ac} = 0.3160 \quad \Delta K_{dyn} = 0.0564$$

$$P_g = 63.2(15.5) = 979.6$$

$$P_a = 3435.6 = 3435.6$$

$$P_{dyn1} = \frac{1}{2}(57.7)(15.5) = 447.2$$

$$P_{dyn2} = 19.23(15.5) = 298.1$$

---

$$5160.4$$

$$h = 6.3$$

---

$$k_h = 0.0 \quad K_{ac} = .2596 \quad \Delta K_{dyn} = 0.0$$

$$P_g = 51.9(15.5) = 804.5$$

$$P_a = 3435.6$$

$$P_{dyn1} = 0$$

$$P_{dyn2} = 0$$

---

$$4240.5$$

$$h = 5.7$$

kh	w1x1	w2x2	w2x3	w4x4	w5x5	w6x6	Pae	h	x	FS
0.5	1127	8043	2281	32462	1102	222185	11332	7.8	13.2	3.02
0.4	1127	8043	2281	23305	1102	159507	8725	7.4	10.7	3.03
0.3	1127	8043	2281	19098	1102	130718	7549.3	7.1	9.4	3.03
0.2	1127	8043	2281	15273	1102	104532	6419.3	6.8	8.1	3.03
0.1	1127	8043	2281	10843	1102	74216	5160.4	6.3	6.4	3.00
0.0	1127	8043	2281	7684	1102	52591	4240.5	5.7	5.0	3.01