



DMSTTIAC

Defense Modeling, Simulation and Tactical Technology
Information Analysis Center

DMSTTIAC TA 98-02

Modeling and Simulation of the SWORD Tactical Missile Defense System

A Technical Assessment

Mark Scott
Science Advisor
IIT Research Institute

Published by:
DMSTTIAC
IIT Research Institute
7501 South Memorial Parkway, Suite 104
Huntsville, Alabama 35802

19980609 031

DISTRIBUTION STATEMENT: Approved for public release;
distribution is unlimited

April, 1998

DTIC QUALITY INSPECTED

REPORT DOCUMENTATION PAGE

Form Approved
OMB No. 0704-0188

Public reporting burden for the collection of information is estimated to average 1 hour per response, including the time for reviewing instructions, searching existing data sources, gathering and maintaining the data needed, and completing and reviewing the collection of information. Send comments regarding this burden estimate or any other aspect of this collection of information including suggestions for reducing the burden, to Washington Headquarters Services, Directorate for Information Operations and Reports, 1215 Jefferson Davis Highway, Suite 1204, Arlington, VA 22202-4302, and to the Office of Management and Budget, Paperwork Reduction Project (0704-0188), Washington, DC 20503

1. AGENCY USE ONLY (Leave blank)	2. REPORT DATE <p style="text-align: center;">April 1998</p>	3. REPORT TYPE AND DATES COVERED <p style="text-align: center;">Technical Assessment 98-02</p>	
4. TITLE AND SUBTITLE Modeling and Simulation of the SWORD Tactical Air/Missile Defense System		5. FUNDING NUMBERS <p style="text-align: center;">DAAH01-95-C-0310</p>	
6. AUTHOR(S) <p style="text-align: center;">Mark A. Scott</p>		8. PERFORMING ORGANIZATION REPORT NUMBER <p style="text-align: center;">DMSTTIAC TA98-02</p>	
7. PERFORMING ORGANIZATION NAME(S) AND ADDRESS(ES) IIT Research Institute 7501 S Memorial Parkway, Suite 104 Huntsville, Alabama 35802			
9. SPONSORING/MONITORING AGENCY NAME(S) AND ADDRESS(ES) U.S. Army Space and Missile Defense Command Weapons Directorate ATTN: SMDC-TC-WC 106 Wynn Drive Huntsville, Alabama 35807		10. SPONSORING/MONITORING AGENCY REPORT NUMBER	
11. SUPPLEMENTARY NOTES This document is available only from DMSTTIAC, IIT Research Institute, 10 West 35 th Street, Chicago, Illinois 60616-3799			
12a. DISTRIBUTION/AVAILABILITY STATEMENT <p style="text-align: center;">Approved for public release; distribution is unlimited</p>		12b. DISTRIBUTION CODE <p style="text-align: center;">"A"</p>	
13. ABSTRACT (Maximum 200 words) This document provides a technical assessment of the SWORD (Short range missile defense With Optimized Radar Distribution) tactical missile defense weapon system. The SWORD system is aimed at providing needed point defense for high value assets, political/civilian areas, and forward area forces. A description of the SWORD system is given along with the mathematical modeling and preliminary computer simulation results (using the Extended Air Defense Simulation - EADSIM) that characterize its angular tracking accuracy and system level effectiveness against saturation attacks by low cost threats that are recent additions to the Air Defense Artillery (ADA) mission area responsibility.			
14. SUBJECT TERMS SWORD, missile defense, modeling, simulation, interferometer, fire control radar, RF command guidance, point defense		15. NUMBER OF PAGES <p style="text-align: center;">15</p>	
17. SECURITY CLASSIFICATION OF REPORT <p style="text-align: center;">Unclassified</p>		16. PRICE CODE <p style="text-align: center;">No Charge</p>	
		20. LIMITATION OF ABSTRACT <p style="text-align: center;">Unclassified</p>	
18. SECURITY CLASSIFICATION OF THIS PAGE <p style="text-align: center;">Unclassified</p>	19. SECURITY CLASSIFICATION OF ABSTRACT <p style="text-align: center;">Unclassified</p>		

Modeling and Simulation of the SWORD Tactical Missile Defense System

A Technical Assessment

Mark Scott
Science Advisor
IIT Research Institute

April, 1998

INTRODUCTION

The U.S. Army Space and Missile Defense Command, Missile Defense and Space Technology, Weapons Directorate in Huntsville, Alabama is working toward demonstrating the capabilities of a new missile defense weapon system called SWORD (Short range missile defense With Optimized Radar Distribution). The SWORD system is aimed at providing needed point defense for high value assets, political/civilian areas, and forward area forces. The concept for this system originated under the Strategic Defense Initiative in 1991 and prototype hardware was developed and tested during SDI. This hardware has served as a basis for evolving the system to the tactical point defense application of SWORD.

This technical assessment describes the SWORD system along with the mathematical modeling and preliminary computer simulation results (using the Extended Air Defense Simulation – EADSIM) that characterize its angular tracking accuracy and system level effectiveness against saturation attacks by low cost threats that are recent additions to the Air Defense Artillery (ADA) mission area responsibility.

SWORD SYSTEM DESCRIPTION

The threat set for the Air Defense Artillery (ADA) mission area has expanded greatly in recent years to include a number of challenging new threats. Beyond traditional fixed/rotary wing aircraft and tactical ballistic missiles (TBMs), the current ADA threat also includes cruise missiles (CMs), air-to-surface missiles (ASMs), unmanned aerial vehicles (UAVs), rockets, and artillery/mortar projectiles. These newer threats represent small, low-cost, numerous, unmanned targets that are often employed with saturation tactics independent of weather conditions.

The SWORD missile defense weapon system offers a cost-effective means of countering the challenging new elements of the ADA threat set. The SWORD system consists of three major components as shown in Figure 1.

INTERFEROMETRIC FIRE CONTROL RADAR

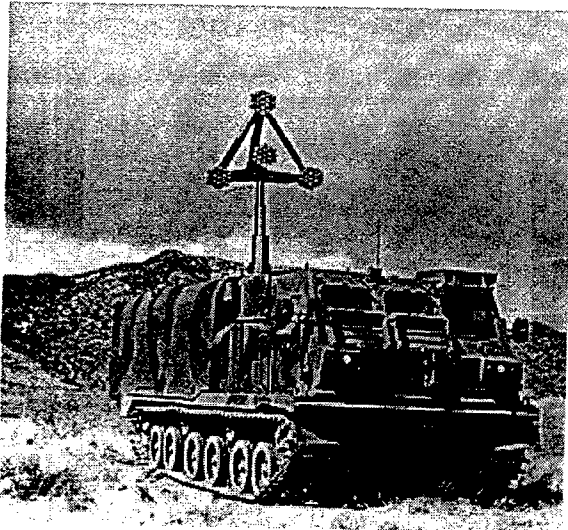

HIGH FIREPOWER TRACKED LAUNCHER (MLRS)

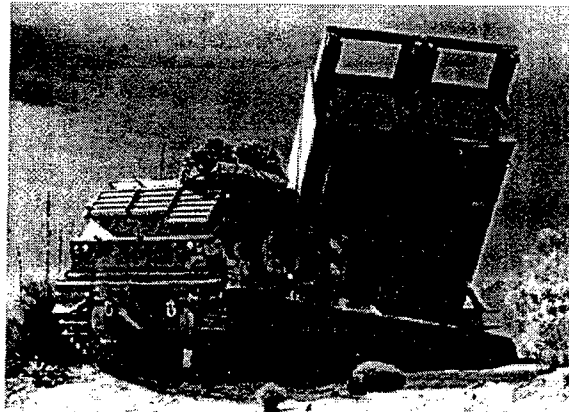

MISSILE - RF COMMAND GUIDED

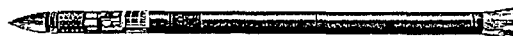

Figure 1. SWORD System Components

The SWORD fire control radar provides target acquisition and multiple target precision tracking via interferometric processing, day or night, in any weather. The SWORD missile is a 2.75 inch diameter, radar command guided interceptor. The precision command guidance provided by the fire control radar makes the lethality of the interceptor high while keeping the cost low by eliminating the need for a seeker. The SWORD launcher can utilize existing air defense missile pods or a new large pod compatible with the Multiple Launch Rocket System (MLRS) vehicle. Operational design of launch pods will accommodate palletized deployment for remote siting at fixed defended assets as well as mobile operation. The radar, missile, and launcher components, integrated together comprise the SWORD weapon system that can operate autonomously or with existing air/missile defense C3I architectures.

The SWORD system thus addresses the challenge of new ADA threats with a high performance interferometric fire control radar to acquire/track numerous small targets and precision guide multiple interceptors in simultaneous engagements. This weapon concept affords SWORD the ability to intercept high densities of inbound threats at low cost per kill. The three major components of the SWORD system will next be described in greater detail.

SWORD Interferometric Fire Control Radar (IFCR)

The IFCR is the key component of the SWORD system. Its angular accuracy enables the command guidance implementation that keeps the cost of the interceptor low by eliminating the need for a seeker. It provides all weather, mobile, 360-degree target search/acquisition, target classification (manned vs. unmanned), multiple target tracking, and multiple interceptor guidance. The 360-degree search is accomplished by mechanically rotating the antenna. The multiple target tracking and multiple interceptor guidance is accomplished by electronically scanning the antenna beams over a solid angular region of space containing acquired targets, while continuing to search for new targets within that same region (i.e., a track-while-scan mode of operation).

The high angular accuracy of the IFCR is derived from interferometric processing – the most accurate technique known for measuring the angle of arrival of radio frequency (RF) signal wavefronts (or any other kind of wavefront for that matter). The SWORD RF interferometry function employs three compact solid state active phased array receive antennas mounted at the vertices of a 3 meter baseline equilateral triangle (the transmit antenna is in the middle – refer back to Figure 1). Figure 2 illustrates the physical basis of the interferometry function.

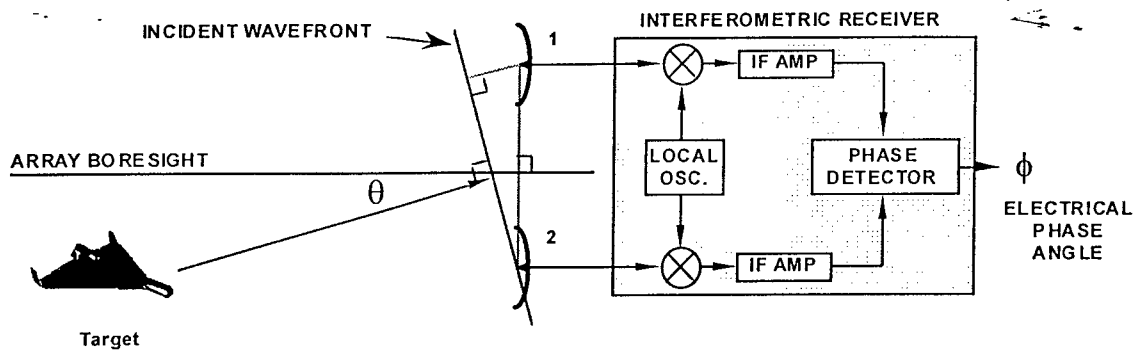

Figure 2. Physics of Interferometry Function

The interferometer receiver shown above has two identical channels that are referenced to a common local oscillator. The wavefront from a target return signal arrives at the two antennas and is processed by the two identical receiver channels. When the signal source is in line with the array boresight, the wave will travel the same distance to the two antennas. The two versions of the signal in the two receive channels will be identical. When the signal source is offset from the array boresight, as illustrated above, the wave must travel further to get to the top antenna. This additional distance causes a phase offset between the two versions of the signal in the two receive channels. The electrical phase difference between the two versions of the signal is measured by a phase detector to allow the system computer to estimate the angle of arrival of the signal wavefront. The interferometer thus converts a small physical angle into a relatively large electrical angle for measurement purposes (Reference 1).

Two channels measure angles in one dimension, and three channels arranged in a triangle measure angles in two dimensions. The accuracy is dependent upon the distance between the antennas, the signal frequency, and the signal-to-noise power ratio (SNR) of the received signal. This relationship is mathematically modeled by the following equation (Reference 2):

$$\sigma_a = \frac{c \cdot \varepsilon}{2 \cdot \pi \cdot D \cdot f \cdot \cos(\theta) \cdot \sqrt{10^{0.1 \cdot SNR}}}$$

where

- σ_a = single measurement angle of arrival error (standard deviation) in units of radians
- c = speed of light = $3 \cdot 10^8$ m/sec
- D = distance between antennas (m)
- f = radar signal frequency (Hz)
- θ = radar antenna scan angle off boresight to target (deg)
- SNR = signal-to-noise power ratio (dB)
- ε = experimentally determined increase in error factor relative to noise-limited lower bound (Cramer-Rao bound) = 1.15

This model for angle of arrival measurement error is physically sensible. Increasing D increases the difference in signal path lengths to the different antennas. Increasing f decreases the signal wavelength which increases the phase difference in the separate signal paths. Increasing SNR makes the measurement of the signal phase difference easier to discern over the noise resident in the receiver's phase detector. All of these increases tend to make the angle of arrival measurement more accurate, hence, the error associated with this measurement smaller, consistent with the mathematical equation. Figure 3 is a plot of the equation for angle of arrival error as a function of frequency and SNR, at the radar boresight, with $D=3m$.

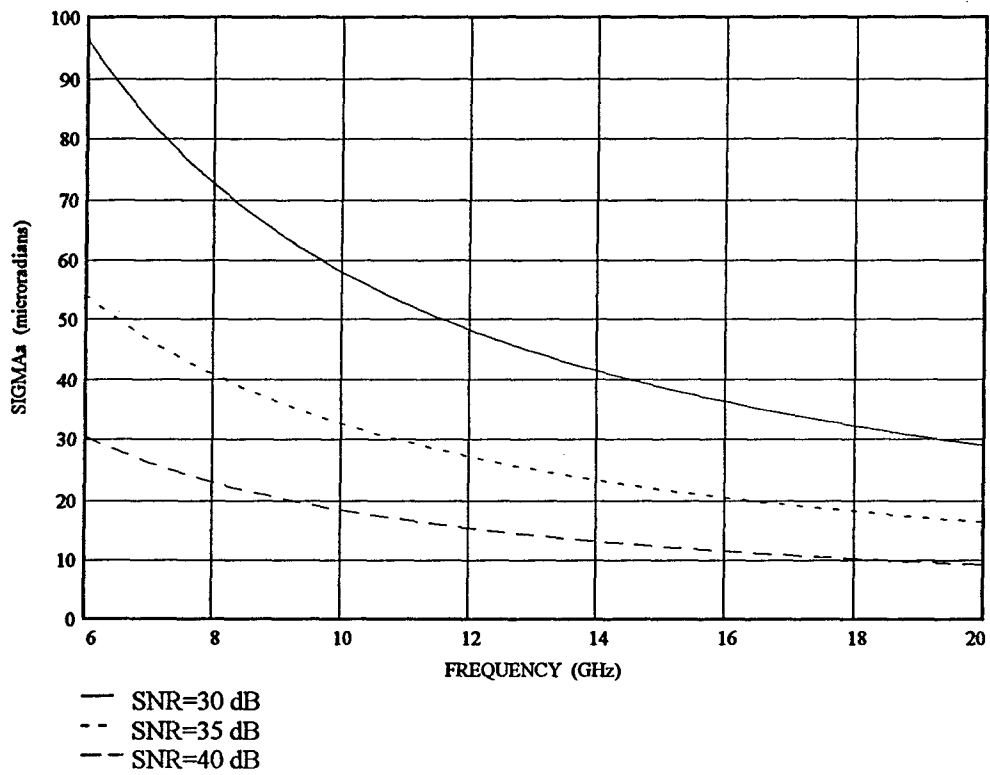

D=3 m THETA=0 deg

Figure 3. Interferometric radar angle tracking error (standard deviation) vs. frequency for 3 different SNRs

A 3m baseline has been selected as the maximum practical size for an interferometer sensor to be employed in a tactical application. From Figure 3 it is apparent that the highest possible choice of frequency will yield the best angle tracking accuracy (smallest errors). A center frequency in Ku band has been selected as the highest practical microwave frequency for the SWORD system. Figure 3 shows that this choice of frequency yields a one sigma angle tracking error of 20 microradians near the radar boresight for SNR=35dB, which is representative of SWORD IFCR accuracy. This translates into a one sigma cross-range displacement error of 20 cm at a slant range of 10 km (see Figure 4).

In other words, each microradian of angle tracking error translates into 1cm of cross-range displacement error at a slant range of 10 km for this example. This small error is on the order of the smallest dimensions of small targets such as rockets and UAVs. Thus, the precise angle measurement capability of the IFCR provides the SWORD system with the ability to command guide intercepts against small, low-cost targets.

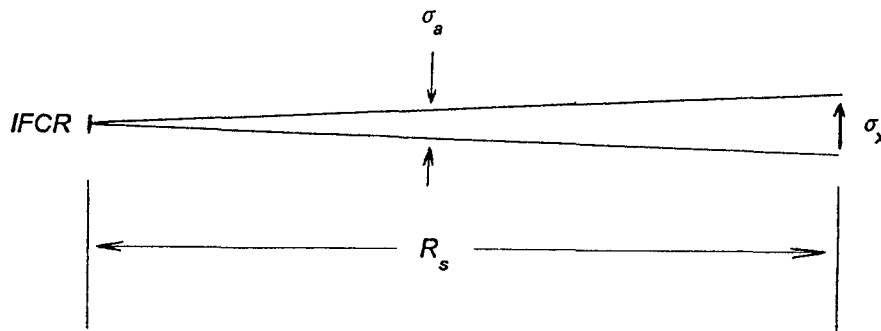

$$R_s = \text{slant range to target} = 10 \cdot 10^3 \text{ m}$$

$$\sigma_a = \text{one sigma angle of arrival measurement error} = 20 \text{ microradians}$$

$$\sigma_x = \text{one sigma cross-range displacement error}$$

$$= R_s \cdot \sigma_a$$

$$= (10 \cdot 10^3) \cdot (20 \cdot 10^{-6}) = 0.2 \text{ m} = 20 \text{ cm}$$

Figure 4. Translation of angle measurement error into cross-range displacement error

Figure 5 shows only moderate increases in interferometer angle measurement error with increasing scan angle (θ) off radar boresight for several different SNRs and design parameter values of $D=3\text{m}$, $f = \text{Ku band}$. The IFCR measures signal angles of arrival most accurately near the radar boresight – measurement errors grow for increasing target offset from boresight. (Note: from here on, read “measurement error” as “measurement error standard deviation”). This relationship is also physically sensible, since for target lines-of-sight at non-zero scan angles, the apparent (effective) interferometer baseline is reduced by a factor of $\cos(\theta)$.

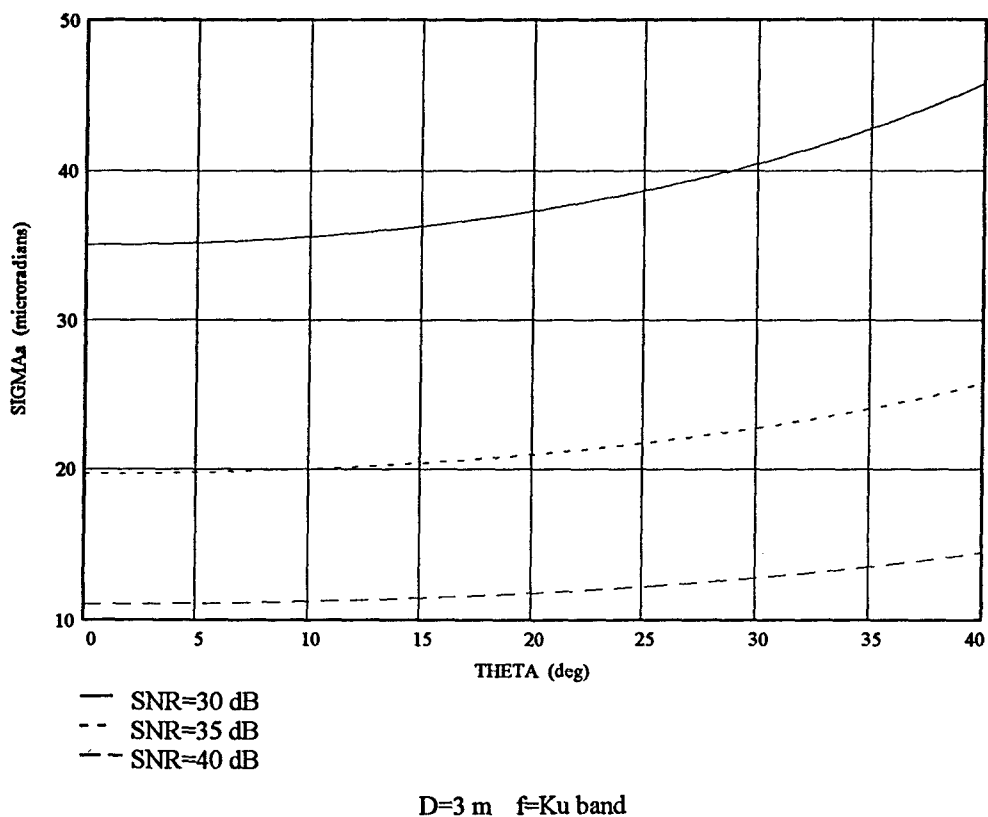

Figure 5. Interferometric radar angle tracking error (standard deviation) vs. array scan angle for 3 different SNRs

Figure 6 gives an approximation to SWORD IFCR SNR as a function of slant range for representative radar design parameter values. The approximations in Figure 6 are representative for both search and track modes of the radar. Note that resulting SNR values are substantially greater than zero such that reliable detections and accurate command guided intercepts can be achieved at significant stand-off slant ranges. (Reference 2).

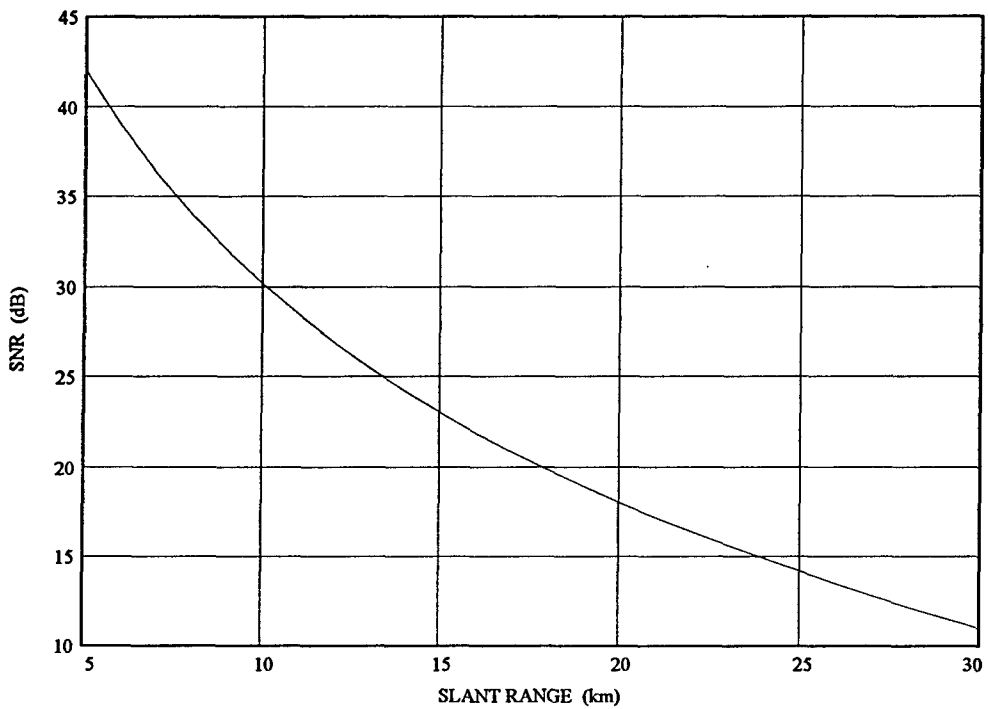

Figure 6. Approximate SNR vs. Range for SWORD IFCR

Potential challenges to the employment of active interferometry for precision RF command guidance lie in the areas of atmospheric refraction and multipath effects. Effects of refraction on RF command guidance accuracy will be mitigated by the fact that resulting measurement errors for the target and interceptor tend to correlate as the intercept distance closes. Hence the refractive error in relative position between target and interceptor approaches zero as the engagement progresses. Despite the fact that the atmosphere induces measurement errors, a collision in true inertial space will be observed as a collision in a coordinate frame that is distorted by the atmosphere. (If a person on the shore of a river tries to throw a spear and hit a fish under water, he will miss, because the fish is not where it appears to be; however, if a person attempts to scoop up the fish with a net on the end of a pole, he will succeed because he can compensate for the refraction induced error as he guides the net to the fish. Even though the net and the fish are not where they appear to be, the relative distance between the net and the fish can be observed and used to guide the placement of the net.) (Reference 1).

Multipath effects are of concern for low altitude targets such as cruise missiles. Multipath signals result from ground reflection in low altitude target profiles and interfere with the direct path radar returns. This can cause severe fluctuations in SNR and degradation in phase and angle of arrival measurements. The multipath advantage that the active interferometer enjoys over other radars lies in spatially diverse phase measurements. The SWORD system is exploiting its multiple receive antennas/channels to resolve the direct path radar return from the specular multipath signal and hence maintain angular tracking accuracy to support command guided intercepts against low altitude targets. (Reference 1).

SWORD Missile

The SWORD missile has a 70 mm (2.75 inch) diameter and a 1.5m length for compatibility with standard launchers. The missile employs a transceiver with body mounted antenna to accept radio frequency (RF) command guidance from the SWORD IFCR. This eliminates the need for a seeker and results in a low-cost round.

The missile is fast and responsive with control provided by a ring of lateral thrusters positioned forward of the center-of-mass. These thrusters induce an angle rate to the airframe resulting in an angle of attack which produces aerodynamic maneuver forces.

Other major subsystems of the SWORD missile include: axial solid rocket motor (high energy propellant); warhead lethality enhancer (flechettes); guidance computer; digital autopilot; 3-axis IMU; and a thermal battery. (References 3 and 4).

SWORD Launcher

The SWORD missile is compatible with standard 70 mm launchers. Consequently, the SWORD system can employ existing air defense vehicles as launchers. The system can also employ trailer or pallet mounted racks of standard launchers for concentrated firepower at point defense sites. Or for concentrated firepower with greater mobility, a large load of SWORD missiles can be tailored to the Multiple Launch Rocket System (MLRS) chassis.

SWORD SYSTEM LEVEL SIMULATION RESULTS

Preliminary system level effectiveness simulations of SWORD have been conducted using the Extended Air Defense Simulation (EADSIM). EADSIM is designed for Monte Carlo system level effectiveness assessments in many-on-many air/missile defense scenarios. Three different hypothetical scenarios have been concocted to assess SWORD's performance in defending areas in South Korea from North Korean rocket attacks. These hypothetical scenarios have been simulated with EADSIM (Reference 3):

1. defense of Seoul from 240 mm rocket attack;
2. defense of Camp Casey from 240 mm rocket attack;
3. defense of Camp Casey from combined 240 mm rocket and cruise missile attack supported by AN-2 Colt surveillance aircraft.

The third hypothetical attack scenario is illustrated in Figure 7.

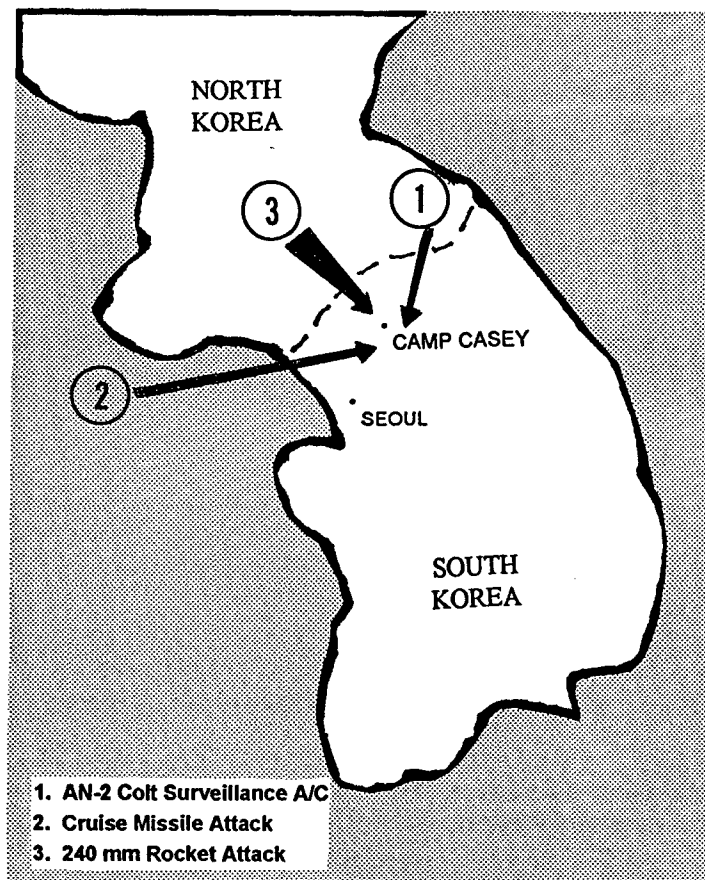

Figure 7. Hypothetical Scenario 3: Defense of Camp Casey, South Korea

In all three of the above simulation scenarios, the 240 mm rocket attack is a saturation salvo by a North Korean heavy MRL (multiple rocket launcher) unit. This rocket salvo is graphically depicted in Figure 8 which shows the salvo arriving in volleys as the launchers in the unit ripple fire their loads of rockets. In the third hypothetical scenario, sea-launched cruise missiles attack the rear area of Camp Casey in addition to the land-based rocket attack. AN-2 Colt surveillance aircraft support the conduct of this aggregate rocket/missile attack. In all three hypothetical scenarios, the SWORD system, with multiple launch platforms, is modeled in an autonomous mode of operation.

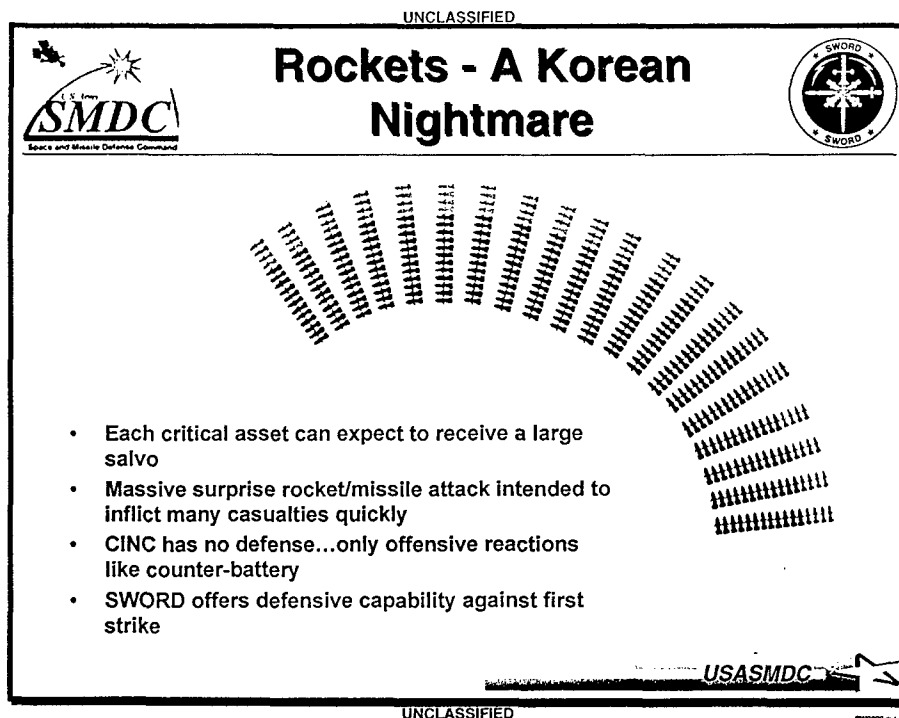

Figure 8. Potential Salvo of 240 mm Rockets

Figure 9 shows representative effects identified from EADSIM results against the 240 mm rocket attacks. The figure shows the vast majority of SWORD intercepts occurring on the initial engagement at the longer ground range and higher altitude. A few intercepts occurred on re-engagement of missed targets at a shorter ground range and lower altitude (shoot-look-shoot mode of employment). However, even these re-engagements occurred at substantial ranges and altitudes, which is highly desirable in light of the fact that the 240 mm rocket is potentially capable of carrying a chemical warhead.

In general, these preliminary results of EADSIM modeling of the SWORD missile defense weapon system are encouraging, showing a high degree of point defense effectiveness against saturation attacks by rockets and cruise missiles.

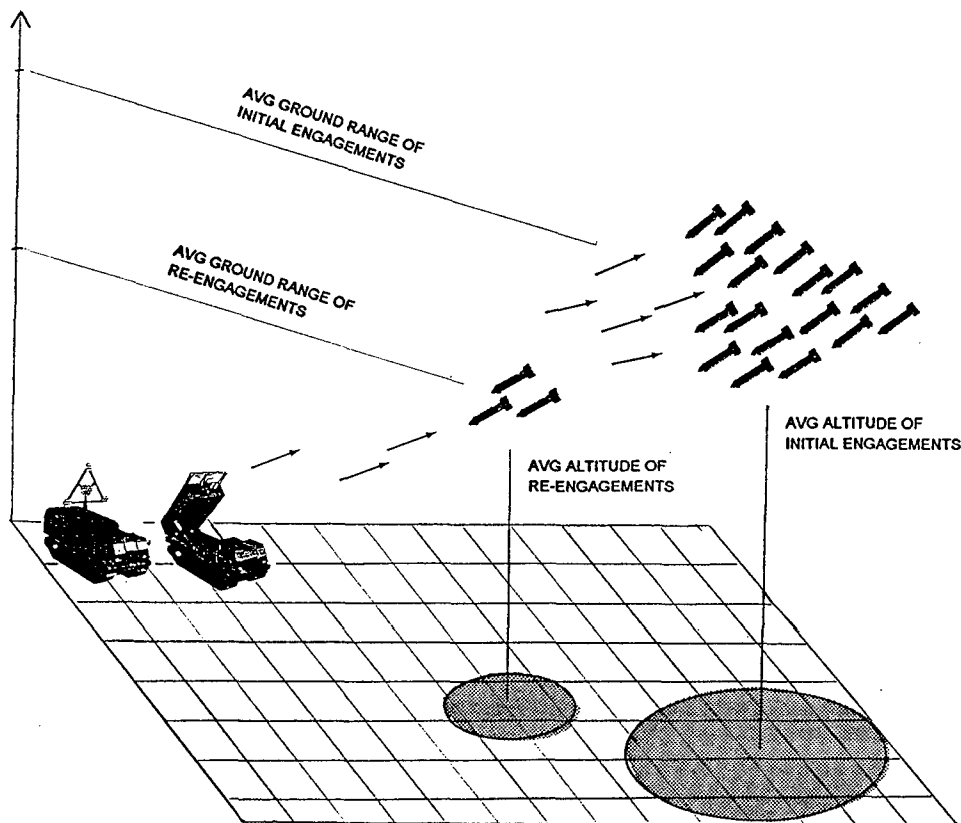

Figure 9. SWORD Intercepts of 240 mm Rockets

REFERENCES

1. "Interferometric Fire Control Radar for SWORD Advanced Technology Demonstration;" R. Smith, B. Pollard, J. Williams, J. Holder; Fire Control Conference 1997, Boulder Colorado.
2. Technovative Applications Technical Memo Dated 20 November 1997, J. Williams.
3. SWORD Analysis Project Briefing, Space & Missile Defense Battle Lab, LTC S. Pierce, 19 December 1997.
4. Delta Research Technical Memos Dated November 1997, A. Spencer.