

340073

JPRS 84578

21 October 1983

# West Europe Report

SCIENCE AND TECHNOLOGY

No. 160

19980609 120



FOREIGN BROADCAST INFORMATION SERVICE

REPRODUCED BY  
NATIONAL TECHNICAL  
INFORMATION SERVICE  
U.S. DEPARTMENT OF COMMERCE  
SPRINGFIELD, VA. 22161

#### NOTE

JPRS publications contain information primarily from foreign newspapers, periodicals and books, but also from news agency transmissions and broadcasts. Materials from foreign-language sources are translated; those from English-language sources are transcribed or reprinted, with the original phrasing and other characteristics retained.

Headlines, editorial reports, and material enclosed in brackets [] are supplied by JPRS. Processing indicators such as [Text] or [Excerpt] in the first line of each item, or following the last line of a brief, indicate how the original information was processed. Where no processing indicator is given, the information was summarized or extracted.

Unfamiliar names rendered phonetically or transliterated are enclosed in parentheses. Words or names preceded by a question mark and enclosed in parentheses were not clear in the original but have been supplied as appropriate in context. Other unattributed parenthetical notes within the body of an item originate with the source. Times within items are as given by source.

The contents of this publication in no way represent the policies, views or attitudes of the U.S. Government.

#### PROCUREMENT OF PUBLICATIONS

JPRS publications may be ordered from the National Technical Information Service, Springfield, Virginia 22161. In ordering, it is recommended that the JPRS number, title, date and author, if applicable, of publication be cited.

Current JPRS publications are announced in Government Reports Announcements issued semi-monthly by the National Technical Information Service, and are listed in the Monthly Catalog of U.S. Government Publications issued by the Superintendent of Documents, U.S. Government Printing Office, Washington, D.C. 20402.

Correspondence pertaining to matters other than procurement may be addressed to Joint Publications Research Service, 1000 North Glebe Road, Arlington, Virginia 22201.

WEST EUROPE REPORT  
SCIENCE AND TECHNOLOGY

No. 160

CONTENTS

BIOTECHNOLOGY

|  |   |
|--|---|
| Fabius Reaffirms Priorities for Research, Cooperation<br>(AFP SCIENCES, 8 Sep 83)..... | 1 |
|--|---|

ELECTRONICS

|  |   |
|--|---|
| Competitiveness of German Microelectronics Industries Analyzed<br>(Dieter Rath; ELEKTRO-ANZEIGER, Feb 83)..... | 5 |
|--|---|

Briefs

|  |    |
|--|----|
| Swedish Firm Sells Software                | 10 |
| Siemens GaAs-FET Strategy                  | 10 |
| Domestic Microchip Production Anticipated  | 11 |
| FRG Research Team To Develop New VLSI Chip | 11 |
| Siemens VLSI Cooperation                   | 11 |

INDUSTRIAL TECHNOLOGY

|  |    |
|--|----|
| French CGMS Strives To Improve Position on Robotics Market<br>(ELECTRONIQUE INDUSTRIELLE, 1 Apr 83)..... | 12 |
|--|----|

|  |    |
|--|----|
| Swedish Robot for Cast Parts<br>(ELEKTROTECHNIK, 18 Mar 83)..... | 15 |
|--|----|

|  |    |
|--|----|
| British Firm Develops First Flexible Workshop for Lathe<br>Work<br>(Michel Defaux; L'USINE NOUVELLE, 25 Aug 83)..... | 16 |
|--|----|

Briefs

|                               |    |
|-------------------------------|----|
| Robots Increase BL Production | 23 |
|-------------------------------|----|

SCIENCE POLICY

Briefs

FRG Tech Transfer Contact 24

TRANSPORTATION

British Leyland's ECV-3 Experimental Car in Road Tests  
(O. Bon Fersen; VDI NACHRICHTEN, 1 Apr 83)..... 25

FRG State, Industry Share Rising Costs of Airbus Venture  
(WIRTSCHAFTSWOCHE, 16 Sep 83)..... 29

## BIOTECHNOLOGY

### FABIUS REAFFIRMS PRIORITIES FOR RESEARCH, COOPERATION

Paris AFP SCIENCES in French 8 Sep 83 pp 1-4

[Article: "I. Scientific Research Policy and Organization"]

[Text] Paris. Mr. Laurent Fabius: Priority to Biotechnologies. Biotechnologies must be given priority both in France and in Europe; this is what Mr Laurent Fabius said in substance on 5 September on the campus of the Pasteur Institute, at the inauguration of a "week of biotechnologies" and the groundbreaking ceremony for a building that will be entirely devoted to these technologies.

The British ambassador, Sir John Fretwell, attended the ceremony during which the minister of industry and research said he was especially pleased by the concomitant creation of an "international biotechnological network," the "materialization" of the cooperation project on "technology, growth, employment" initiated by President Mitterrand at the Versailles summit in 1982.

The object of this network, the minister said, is "quite simply to prepare our future and make sure that we can control it."

"The scope of this task, the difficulties it involves, the prospects it opens obviously call for international cooperation, a source of progress and mutual confidence for countries in the North as well as in the South," the minister added, recalling that the network--the president of which is Mr Pierre Douzou and the vice-president the British Professor Coleman, "government chemist" at the British Department of Industry--would not only manage the exchange of information between member countries (France, Great-Britain, Canada, Japan and the European Communities), but would also contribute to the training of future biotechnologists and would manage joint projects.

In agreement with the wishes expressed at the Versailles summit, the network will also contribute to improve the transfer of knowhow from the North to the South. "This will mark the beginning of a new step, a modest one, but a material one and, maybe, in the long term a decisive one, toward a new world economic order of shared progress."

"The international network remains to be created," the minister acknowledged, but "the political determination to achieve it has been clearly expressed at the highest levels." With biotechnologies, he pointed out, "we are at the heart of what is sometimes called the new alliances, a new type of relations between man and its environment, between man and nature."

Basic research is essential, but the utilization and transfer of "knowledge deposits" to convert them into industrial knowhow is just as important, Mr Fabius added. Both are indissociable if biotechnologies are to help us "produce more and at a lower cost, with a minimum of risks to the environment" a whole range of new products, such as vaccines, antibiotics, vitamins, hormones, solvents, fuels, fertilizers, pesticides, new seed varieties, new food products for human and animal consumption.

To succeed in this field, "it is clear that next to the life science disciplines, data processing will play a prominent role." "The 21st microcomputers associated in one and the same task." [as published]

The creation of the international network is one of the elements that "will make it possible to shape tomorrow's society, based on what we are still calling 'the technologies of the future': biotechnologies, new materials, electronics, data-processing and robotics.

#### Groundbreaking Ceremony for the Biotechnology Building

Speaking again at the groundbreaking ceremony for the Biotechnology Building of the Pasteur Institute, Mr Fabius said he was pleased that "biotechnologies are taking, or rather reasserting, the place that should be theirs," and that "one of our oldest scientific institutions" thus showed that "once again it has understood its time and is making its mark on it."

According to the minister, the fact that the laboratory will be open to researchers (INSERM [National Institute for Health and Medical Research], CNRS [National Center for Scientific Research], universities) other than the institute's provided again material evidence of the "Pastorian spirit of renewal." "French history has ill prepared us to this shared fecundation (...) but, in the 1980's more than ever, interdisciplinary research, contacts between brains with different makeups, the confrontation of their experience, the coming together of disciplines," are needed if we are to progress.

#### Necessity for International Cooperation

French research and technology should increase French influence abroad. "We must develop our fields of cooperation (a tradition at the Pasteur Institute), especially with developing countries and our European partners, without which we could not reach the critical threshold that enables us to be competitive on international markets in many fields," the minister added; he then went on :

"1984 will give us a chance to take important initiatives. It will be France's turn to chair the European Community and the conference of the European Council science ministers--which is likely to take place in Paris next year--will give me a privileged opportunity to develop new cooperations."

## French Assets and Efforts

"However, there can be no international cooperation unless we have ourselves the means to keep up our position. (...) France has appreciable assets:"

"- High quality basic research;"

"- A dense and diversified industrial fabric in which large enterprises (especially in the pharmaceutical sector) and enterprises of a more modest size (agrifood sector), play complementary parts, often with great success;"

"- Our country has a wealth of plant materials that can be widely used by these new industries."

In addition to the "mobilizing research and development program for the biotechnologies," one billion francs were earmarked for these technologies in 1983, the minister recalled.

CNRS and INSERM have made unprecedented efforts respectively in microbiology (fermentations) and in the use of animal cells to manufacture antibodies for medical uses--which materialized in the creation of Immunotech. The INRA [National Institute for Agronomic Research] created a plant cell research center for the creation of new species and the improvement of older ones. The Pasteur Institute created Hydrolab, a company that manufactures antibodies for medical and veterinary uses. Ten enterprises or so were created or developed their activities in the field of biotechnology.

Although "things are moving and the first results are rather promising," the minister acknowledged, "it is not enough." Therefore, the government has decided to take the following measures to help the expansion of biotechnologies in France:

1. Incentive state credits for biotechnological research will be given priority in the Ninth Plan budget. Credits will be allocated by priority to joint projects of public and industrial research organizations that would lead to an improvement of the technological level of French enterprises.
2. The authorities will consider increasing the means devoted to basic research in research organization laboratories, and will also encourage the transfer of the knowledge and knowhow thus acquired to the industry. "We must strengthen industrial research where it already exists and create it where it does not yet exist, and we must do more than has been done until now."
3. One of the top priorities of the industrial modernization fund will be to consider the bio-industrial sector. It will thus expand and increase the efforts made by CODIS [Committee for the Development of Strategic Industries]. "The industrial facet of the program is, in my opinion, especially important. (...) The public organization will not mean much unless our enterprises take an active part in it."

4. Data and strain banks will be created; they will rely on the expertise of the Pasteur Institute, the Museum of Natural History and the Paris-V University.
5. An expert-training program (researchers and engineers) will be prepared during the next few months jointly by the Ministry of Industry and Research and the Ministry of National Education. The Ministry of Industry and Research will redirect its research subsidies.
6. Finally, the regions will be asked to define objectives and programs compatible with their scientific, technical and industrial potential.

#### The Biotechnology Building of the Pasteur Institute

Construction of the biotechnology building of the Pasteur Institute was decided by the authorities to house at a single location all of the Institute's teams involved in biotechnological research (fundamental or applied) which are now distributed all over the campus.

Its total cost, including the equipment, will amount to 83 million francs (60 million francs to be provided by the state for the building, 23 million francs by the institute itself for the equipment). The building is scheduled to be completed by 1986.

It will house 100-150 researchers plus a corresponding number of engineers, technicians and administrative personnel on the 10,647 square meters of office and lab space that will be built on the 3,000 square meters reserved for it on the institute campus, in the heart of Paris.

Its objective will be to encourage technology transfers between research and the industry. An attempted agreement between the Pasteur Institute and the industry failed in 1979.

The laboratories that will be housed in the building will work, among other things, in the field of health: preparation of new vaccines through genetic engineering, new diagnostic tests, the applications of neurobiology and neuropharmacology. In industrial microbiology, research will be carried out on the production of biofertilizers, biopesticides, animal feed proteins, biofuels, cellulose-degradation products.

At the ceremony, Prof Francois Jacob, Nobel Prize winner, chairman of the board of the Pasteur Institute, emphasized that this groundbreaking ceremony was "a symbol of the vitality, the dynamism and the revival" of the organization.

"It is significant that this building should be devoted to the very field invented by Pasteur (...); to allocate a full building to this field is also to lay a wager on the future, to expect that in years to come biological research will make an important contribution to technology and industry." Let us hope, Professor Jacob added, that the foundation stone we are now laying "will also be the corner stone of a great enterprise in which research and industry will at last cooperate in the field of biology."



COMPETITIVENESS OF GERMAN MICROELECTRONICS INDUSTRIES ANALYZED

Essen ELEKTRO-ANZEIGER in German Feb 83 pp 14-15

[Article by Dipl. Krm. Dieter Rath, ZVEI, Frankfurt, "The Future with Micro-electronics"]

[Text] Among the large industrial branches of the German economy, the electrical industry occupies a position with sales of about 118 billion DM and about 940,000 employees. From tiny electronic components up to turn-key major power plants--that is the extent of the product spectrum. The focus of production--nearly two-thirds --lies with capital goods. The growth factors in this area in recent years were especially communications technology and data processing.

The electrical industry participates decisively in the development of the German national economy, as one of its engines of growth. Thus, German industrial production since 1950 has risen fourfold, but production in the electrical industry increased by more than tenfold. If profound disturbances did not occur in recent years, especially in the construction of power plants and in communications technology, the German electrical industry would have developed still more impressively.

Stagnating Demand

For nearly 2 years, domestic orders have been declining, and foreign orders have been falling since the middle of 1982. This led to a continuing downwards trend during the past year. Only one major power plant order in November and impulses through investment conditions in December prevented the orders received for the entire year 1982 not going into the red, even with nominal consideration. In terms of prices, they declined by 3.5 percent.

The demand for electrotechnical capital goods stagnated (real: - 4 percent). Only data technology recorded strong growth orders (+ 15.4 percent). The orders from communications and information technology (without EDP) grew by 6.5 percent, and high power engineering declined by 3.7 percent. The demand for electrotechnical consumer goods declined by 1.5 percent (real: - 4.5 percent). Here, orders in entertainment electronics showed a positive development due to good business with video recorders (+ 12.5 percent). The manufacturers of electronic components

could also book growths (+ 5.4 percent) in this vortex. On the other hand, the demand for electrical household devices declined by nearly 8 percent, and declined about 6 percent for illumination and lights.

#### Increased Efforts for Export

The electrical industry as well as the other major industrial branches were exposed to severe effects from the business cycle during the previous year. The businesses could counter these effects only by increased efforts for export. Exports rose by about 11 percent and reached a volume of 49 billion DM. They thus occupied more than a 54 percent share of production. If one counts the indirect exports--built into more highly processed products--the export quota then exceeds 60 percent. The weak German domestic picture had a negative effect on the imports of electrotechnical products. After 2 years of two digit growth rates, the increase in 1982 was a bare 5 percent, a relatively modest figure. The import volume was about 31 billion DM. The proportion of imports in the domestic market supply nevertheless rose to 43 percent. The export excess in the electrical industry rose from 14 to 18 billion DM within one year, and again contributed decisively to relieving the German balance of payments.

In the post war period, the German electrical industry has succeeded in again becoming a top group in international electrical engineering. Electrotechnical products have captured a rising portion of the total German export of merchandise (1982: about 11.5 percent). The value of electrical exports from the Federal Republic exhibited annual growth rates between 10 and 20 percent up through the middle of the seventies. In the course of slowed growth--especially in Western Europe which picks up about 70 percent of the German electrical exports--the growth rates first declined clearly. Since 1980, the growth rates again have been in two digits.

#### Top Position in Export

The portion of the German electrical industry in the world electrical export rose from barely 6 percent in 1950 to 18 percent in 1970. At the same time, world trade with electrical products grew mightily: Volume rose 13 fold. From 1970 until to date, world electrical export then tripled again, whereby the German portion could be maintained essentially constant. The German electrical industry thus occupies third place in the world ranking list of exporters, behind the USA and Japan.

In the relatively parallel rise of the import and export quotas, one can see the increasing international division of work. The German electrical industry itself contributed to this through its foreign investments, which in the meantime have reached nearly 7 billion yen.

Although new locations with more favorable cost circumstances (East Asia) or cost-dependent price formation (Eastern block) severely impair the German electrical industry in its unfolding of foreign business, the Federal Republic accounts for nearly one-fifth of world export in this branch, and belongs among the few major exporting countries. In consideration of more and more new competitors on international markets, especially in the developing countries, it is improbable, how-

ever, that the German portion can continue to grow in the future as it has in the past. The future growth potential therefore depends more on the development of a total world market than on capturing shares in the electrical world trade.

### International Competitiveness Threatened

The question of international competitiveness in the electrical industry is closely connected with the development of foreign business. This question arises because the profitability and the net worth of the electrical industry have recently fallen to a completely inadequate low level, and assistance in the present tempo of innovation thus becomes more and more difficult. The question arises all the more as it seems that the German electrical industry has a nearly irretrievable lag in the basic innovation of the eighties--microelectronics--as compared to its main competitors, the USA and Japan. While the consumption of microelectronics per capita increased by about 25 percent between 1980 and 1982 in the USA, it presumably will double by 1986, the rise in the Federal Republic between 1980 and 1982 is only 10 percent. Estimates cause one to suspect that, despite a strong increase by 1986, only half of the electronic per capita consumption of the USA and Japan will occur, where developments will presumably be in parallel.

What are reasons for this? The USA not only has a time lead in product and market development, it also has a decidedly innovative demand behavior in its domestic market. This also holds for the strong impulses which emanate there from government demand. American manufacturers enjoy broad procurement programs and large, fully financed research and development contracts, which relieves them from development and sales risks. The procurement program of the US government in 1981 reached an amount of 27 billion dollars for electronic products. This corresponds to a 25 percent fraction of the total US market. On the basis of this enormous sales market, the American electrical industry succeeded in producing more than 60 percent of the total world demand of integrated circuits.

The advantages of the Japanese enterprises primarily lie in the fact that they are supported by a domestic market which de facto is reserved completely for themselves, and that they can therefore practice a targeted export strategy. If a country with a high technological development status and the enormous capitalization power of the Japanese economy concentrates its efforts on a few market segments, it closes market access to other competitors, and this on a world wide scale. With the policy of creating production capacities which are larger than the medium-term expected world market volume, the Japanese themselves constrained themselves to forced export, which excludes normal competition.

### Acceptance Problems with Microelectronics

In the Federal Republic, on the other hand, so-called acceptance problems inhibit the successful introduction and expansion of microelectronics. The more and more frequently heard opinion that increased use of microelectronics would lead to still more unemployment overestimates its job-release effect. It underestimates the positive effects on the social product, effects which are associated with greater efficiency. It also underestimates the international competitive position and total employment. In fact, the new microelectronic techniques have been researched,

developed, and converted into industrial practice at considerable costs. Since costs are always at the same time income, microelectronics has created and maintained jobs before it has ever released jobs. With its application, productivity and thus real income rises. The resulting demand creates jobs in a fashion that is conformable to stabilization.

In view of jobs, it is perhaps even more important that microelectronics and the techniques emanating from it encounter a gigantic and rapidly growing sales potential all over the world. Thus, for example, the demand for electronic components is doubling every cycle of every five to six years. A national economy which specializes in leadership in the development and production of these products will achieve a stronger and stronger international competitive position through increasing comparative cost advantages. Thus, the chances of achieving and maintaining high employment will improve. The better the position of the country in the specialization pattern of international work division, the more secure are the jobs in this country.

In the debate concerning this point, the decisive question is raised only rarely and is answered still more rarely. The question is: What would happen if we were to refuse to use the new technologies in our highly industrial country, but a country which is poor in raw materials? The answer is clear: An ever worsening permanent crisis would ensue, without hope of ever decreasing the number of unemployed. Since we do not seriously have the option of giving up microelectronics, the policy of delaying its application is costly and dangerous.

#### Uninterrupted Innovative Power

In the area of electrical engineering there are more than 100,000 products. It is nearly impossible for a single country to occupy a top position everywhere in this area. But there is no area in which the German electrical industry has an irretrievable lag. The problem is not to be viewed in technology but especially in the trend of falling capitalization power, which is the result of a high and increasing competitive intensity, desirable from an economic-political point of view, and of increasing labor costs. For this reason, a wage policy which dampens labor costs for long-term competitive position is of outstanding significance. The high technological intensity of the German electrical industry is both the cause and effect of overall economic innovation and investment processes. In the future too, it will participate more than proportionally in economic growth, on account of its central position, because its innovative power is unbroken.



## ELECTRONICS

### BRIEFS

SWEDISH FIRM SELLS SOFTWARE--The Swedish consulting firm Viak has sold its computer-supported coordinate-computing program HPRIT to the state enterprise Strojexport in Czechoslovakia. The price, 170,000 Swedish kronen, amounts to only about one-tenth of the price of corresponding programs by other manufacturers. For Viak this is the first HPRIT export contract and at the same time a breakthrough into the East European markets for digital map production. The Czech firm will use the HPRIT program in the planning of a large irrigation installation in Iraq. The Swedish program was selected because, among other reasons, it is easy to use, can be employed in an ordinary tabletop computer and can operate in conjunction with any curve-drawing instrument. In addition, it can draw maps in color. The data input is accomplished interactively, manually or via a data card file. The calculator carries out coordinate calculations from the measured data and draws a map by means of the curve scribe. The shift from transverse to longitudinal profile presents no difficulties. The HPRIT program is used in Sweden by, among others, the State Railway for setting up railway routes and is used by the counties for large-scale cartography. [Text] [Leinfelden-Echterdingen DIE COMPUTER ZEITUNG in German 30 Mar 83 p 32] 8008

SIEMENS GAAS-FET STRATEGY--In the FRG Siemens is the only manufacturer of GaAs-FET's. Juergen Hammerschmitt, marketing manager for microwave semiconductors, has announced to the electronics industry: "Naturally we also aim at volume applications and look for them primarily in the domain of TV satellite receivers. We believe that a cheap GaAs-FET is one of the key components. For this we have the cost-favorable ceramic housing called Cerec and we are already offering today the CFY 14 at a price under 30 DM per piece in batches of 100 and at 20 DM in batches of 1,000. At the present time Siemens does not plan taking the step in the direction of UHF and VHF with GaAs. The price/performance ratio is still better with Si-MOS-FET's. The low noise of the GaAs-FET's is not important in entertainment electronics; perhaps, however, in mobile radio and I would not exclude the possibility that some day we might climb aboard. First of all, we want to concentrate on the microwave domain where with the CFY 15 we are manufacturing an 0.5- $\mu$ m FET with less than 2.2 db noise at 12 GHz." Siemens continues to be the only firm which in the model series CGY 20, CGY 30, CGY 21 and CGY 31 also offers mass production of monolithic GaAs broad-band amplifiers up to 3 GHz. [Text] [Heidelberg ELEKTRONIK INDUSTRIE in German Mar 83 p 71] 8008

DOMESTIC MICROCHIP PRODUCTION ANTICIPATED--Danish businesses are now getting the possibility of developing their own microprocessors--popularly called chips--for some of the most advanced computer equipment in the world. The Electronics Center is now opening a design center, the facilities of which are being placed at the disposal of Danish industry. The design center is being equipped with computers for computer aided engineering (CAE). Three-fourths of the equipment is already installed, and over the next few years the last section will be completed. The total expenditure will be 6.5 million kroner. The design center has three design engineers who were trained at the Danish Technical College's Semiconductor Laboratory. [Text] [Copenhagen BERLINGSKE TIDENDE in Danish 30 Sep 83 Sect III p 2]

FRG RESEARCH TEAM TO DEVELOP NEW VLSI CHIP--A special research area of the German research community has been founded at the universities of Saarbrücken and Kaiserslautern. This special department is supposed to bring the Federal Republic of Germany closer to the highly developed technologies of Japan and the USA. As a long-term objective of the development work, the scientists wish to house about a million circuits on one silicon chip of only 20 mm<sup>2</sup> surface. With very large scale integration (VLSI), the information scientists in the new special research department "very large scale integration--design methods and parallelism" try to work out the theoretical principles for assembling the largest possible number of micro-electronic circuits in the smallest space. They are thus entering a hard competition with researchers in the remaining industrial nations, especially Japan and the USA. The Japanese have already accomplished 250,000 switching circuits of the desired one million on one chip, on one integrated circuit. The German research community has made available to the information scientists an initial sum of 5.1 million DM for their project in the next three years. The new special research department will work very closely together with business. What the information scientists develop will immediately be used practically by Siemens. Thus, the new special research department might even be more than merely a springboard so that in the race for the microchip million, the connection with international competition will not be missed. Beyond doubt, it will open up new dimensions for German computer technology. [Excerpt] [Duesseldorf VDI NACHRICHTEN in German 1 Apr 83 p 28] 8348

SIEMENS VLSI COOPERATION--The Society for Mathematics and Data Processing (GMD), St. Augustin, and the Siemens AG, Munich, have agreed to collaborate in the area of highly integrated technology. First, it is planned to develop a VLSI module "error-tolerant memory interface", which is supposed to be used in microcomputer systems. According to its own data, the GMD is working out the circuit design and is here using design methods and tools available at Siemens. At the same time, some of these tools are being taken over and their functional scope is being expanded. The contribution of the Munich concern consists in fabricating a chip according to the VLSI design and in supporting the designer work by the required consultation and services. By the end of the year, samples of the chip are supposed to be available, and are supposed to be inserted into a laboratory. [Brief] [Munich COMPUTERWOCHE in German 4 Mar 83 p 2] 8348

CSO: 3698/440

## INDUSTRIAL TECHNOLOGY

### FRENCH CGMS STRIVES TO IMPROVE POSITION ON ROBOTICS MARKET

Paris ELECTRONIQUE INDUSTRIELLE in French 1 Apr 83 pp 4-5

[Article by P.I.: "CGMS Expands Its Activities"]

[Excerpts] Within the Alsthom-Atlantique group, the CGMS [General Handling and Storage Company] has just been assigned responsibility for the study and development of "ready for use" flexible workshops, which will actually be complete production systems. This decision is a result of the group's intention to take a significant position in the robotics and flexible workshops market.

The CGMS was founded in 1961, and since 1978 has been a wholly-owned subsidiary of Alsthom-Atlantique. It has now become the leading European manufacturer of handling, storage, and hoisting equipment. In 1982 its total sales (up 30 percent from the preceding year) came to 264 million francs. For the past 4 years, the company has had a growth of over 20 percent. Despite an environment that has been made more difficult by the strong competition from small manufacturers and the drop in market volume, the "hoisting" division, which in 1975 took over the "cranes" activities of Unelec, in 1982 had sales of 100 million francs, half of which came from the export market.

These results can be attributed to changes in the company's products (traveling cranes, cranes which can lift very heavy weights, and automatic hoisting and aerial handling systems) which today make use of new mechanisms (hydraulic hoisting system, acceleration and deceleration control) and of electronics for weighing and radio control. By relying on an extensive level of standardization and the use of new production facilities, the CGMS has now become the leading French manufacturer of traveling cranes, having produced over 400 of these cranes (ranging from 500 kilograms to 120 tons) in 1982.



The "automatic storage" division, which lists among its credits about 100 systems installed in Europe and nearly 400 automatic translation devices, in 1982 had sales of 120 million francs, and received 22 orders for systems including tank, pallet, and warehouse storage equipment for "long" products (over 6 meters in length). Of these 22 systems, nine are for the storage of products being manufactured, seven for the storage of raw materials, and only six for the storage of finished products.

These good results, though, should not be allowed to obscure the fact that the current economic situation is quite grim. For this reason it has been decided to redirect the company's activities toward the robotics and flexible workshops markets.

Along with its traditional activities in the areas of automatic storage and hoisting, the CGMS will also be responsible for the management of materials in the shop and for the development of "ready for use" flexible workshops, which are actually complete production systems.

#### A Move Made without Worry

According to Mr Bondoux, the chief executive officer of the CGMS, this new activity is the logical outcome of the skills the firm has acquired. For, in addition to its mastery of problems related to automatic storage and handling equipment, the CGMS has also acquired competence in problems related to automation and computer systems. Therefore, its skills now cover all of the constant elements found in flexible workshops (machine-tools are considered variable elements). Moreover, the company has supported systems studies by creating multidisciplinary groups to study functional problems. By maintaining close relations with a number of foreign manufacturers, particularly in the United States, the Federal Republic of Germany, and Japan, it is easy to understand, as Mr Bondoux says, that the CGMS can make this move without worry.

One flexible workshop for which the CGMS is prime contractor is now being built in the Alstom-Atlantique plant at Aytre (La Rochelle). This shop, which will produce over 10,000 types of parts used for making cars for subways, the TGV [High-Speed or "Bullet" Trains] and the Corail trains, should lead to productivity improvements on the order of 3, and we must add, also reduce personnel by half. Other projects are also underway, though we can not now obtain fuller details, as the companies involved want to maintain secrecy about these projects.

## European Ambitions in Robotics

In robotics, in addition to the "Skilam" assembly robots made by Sankyo, and sold in the United States by IBM, the CGMS, since the agreement signed in January 1982 with the Japanese company, Toshiba, has been selling the "Tosman" robots.

This robotics activity is also aided by a systems approach; the robots are not sold as a product but rather as systems. To do this, the CGMS has set up teams to develop grasping systems (pincers, clamps, etc.) and software adapted to the applications and environment in which these robots are used.

This "systems" approach is now beginning to be fully appreciated, as we see the integration within Alsthom of the CEM [Electro-Mechanical Company] and of its subsidiary, SCEMI [expansion unknown], which also sells an assembly robot. According to the directors of the CGMS, the "Skilam" robots are only sold as integral components of a system, and they are not at all competing with the SCEMI robots.

However, there can be no doubt that the group's robotics strategy will require close cooperation between the three companies involved: CGMS, SCEMI, and ACB [Brittany Construction Company] which sells remote handling devices and a welding robot developed in cooperation with OTC [expansion unknown], and which is to sign shortly a development agreement with the CEA [Atomic Energy Commission] to develop a welding robot.

The ambitions of the CGMS in robotics are aimed primarily at the conquest of the European market. In 1982 it sold only about 30 "Skilam" robots in France, and some "Tosman" units, while during that same year, Sankyo sold over 1,000 units in Japan. The prospects for 1983 hardly look any better, since the sales forecasts indicate about 100 robots sold with a CA [Total Sales Revenue] of about the same level as in 1982. This means that in the present state of affairs, the CGMS is hardly going to consider producing its own robots.

7679

CSO: 3698/2

## INDUSTRIAL TECHNOLOGY

### SWEDISH ROBOT FOR CAST PARTS

Wuerzburg ELEKTROTECHNIK in German 18 Mar 83 p 12

[Text] In the foundry of the Volvo Komponenter AB in Arvika the cleanup of heavy castings is taken over by an integrated manufacturing cell which is equipped with four tools. An industrial robot is the center of this installation which has been developed and is being supplied by the ASEA.

With its 450 employees the foundry in Arvika produces annually about 25,000 tons of automotive parts for the most part consisting of graphite-shot castings [Kugelgraphitguss].

It is becoming increasingly difficult to find personnel for the stressful and unhealthful work of casting cleanup. For this reason there has been installed in Arvika an industrial robot having a carrying capability of 60 kg and a positioning accuracy of  $\pm 0.4$  mm.

In rework of transmission housings the riser is first separated from the ingot; this is accomplished when the robot presses a hydraulically driven separating disk against the casting. Having been reduced now to a weight of 55 kg the part is then lifted by the robot and successively applied with high precision to the fixed tools.

The outer edges of the transmission housing are polished and the interior metal shavings removed by means of a compressed air hammer and a rotating file.

The entire cleaning program lasts 9 minutes as compared with 12 minutes for cleaning by hand. The time saving is thus 25 percent and at the same time one obtains higher and more uniform quality.

The manufacturing cell is supplemented by a manipulating and storing facility developed in Saffle by MHT System; this storing and manipulating facility is capable of simultaneously taking up 96 parts and delivering them automatically to the robot. This permits unmanned nighttime operation.

8008

CSO: 3698/3

## INDUSTRIAL TECHNOLOGY

### BRITISH FIRM DEVELOPS FIRST FLEXIBLE WORKSHOP FOR LATHE WORK

Paris L'USINE NOUVELLE in French 25 Aug 83 pp 51-53

[Article by Michel Defaux: "Lathe Work: the First Flexible Workshop"]

[Text] Until now, flexible workshops have essentially been machining centers. Now a "first" has been created in England: the Scamp unit of the Group 600, working in Colchester, has developed a flexible workshop for revolving parts. Our special reporter visited this facility, which combines high-tech machine-tools, vision systems, and robots.

"In recent years, we have solved the problem of the assembly and finishing of bottom-of-the-line lathes by installing a moving assembly line like the ones used in automobile plants. But there was still the problem of producing separate parts," explained Peter H. Cook, director of Scamp System Ltd, which belongs to Colchester. Colchester, which is a member of the Group 600, one of the largest producers of machine-tools in the world, produces 200 lathes a week. It takes about 2 days to complete one machine. But for revolving parts (pinions, shafts, crown gears), the production time, because of the multiple steps involved, was close to 8 to 10 weeks, or even longer. "With our flexible workshop, we now get comparable production times."

This facility, one of the first flexible workshops in Great Britain, is a formidable technological display which should encourage British industries to follow this course. This is why the ministry of industry has been closely involved in this development which cost 3 million pounds (people talk of a 2-million pound subsidy).

This workshop, which has been in operation since the start of 1983, provides a striking demonstration of the company's potential. Before the end of 1983, the project engineers hope to

market all or part of the system, not including the current technical spinoffs in machine-tools and robots (the Group 600 has signed an agreement to manufacture Fanuc robots under a license in Great Britain).

"Most flexible workshops consist of machining centers with long cylinders, which are easy to automate. But our strengths are in the field of lathe work, so we built a flexible workshop for revolving parts. To the best of our knowledge, this has never been done before," said Peter Cook, who cited the three basic guidelines underlying the shop's design: to reduce the number of handling operations, to increase the number of operations done on one machine-tool without stopping, and to manage to combine these two factors. "But there is no special recipe, for everything depends on what you produce."

The flexible workshop is installed in a long building bisected lengthwise by several conveyor belts. On one side there are nine machine-tools controlled in a CND [Direct Numerical Control] link (seven CNC [ Numerical Control] machines and two conventional machines), which are supplied by eight Fanuc 600 robots. On the other side of the belts are six loading and unloading stations for parts in this circuit. "As we have small parts, the use of wireguided carts was not suitable here." There is a conveyor belt on rollers operating in a closed circuit (transfer of parts on pallets circuit) surrounded on each side by a small section of conveyor belt running in the opposite direction (machine buffer-stock, parts input and output buffer-stock). In order to move the pallets carrying the items from the transport circuit to the machining or output circuit, pneumatic guides are operated by the central computer. That is what the shop looks like!

The parts machined here are revolving parts (shafts, discs, gears, crown gears) made of steel, cast iron, or aluminum, for the various companies belonging to the Group 600. They are machined in batches of 50 to 150 units and, depending on their type, are given different machining treatments: lathe work, drilling, milling, cutting of gears, trimming, grinding of gears, cylindrical grinding, cutting of cotter slots by milling (shafts) or by broaching (discs).

The types of machining and the machine-tools were completely reviewed and modified in order to combine a maximum of operations on one machine. For example, a shaft that had required five successive operations is made here in a single operation, using a five-axis lathe, with the possibility of drilling and honing.

The robots, equipped with pincers that can pivot along a 180° angle, turn the parts around on the machine-tools during the cycle. And finally, a trimming and bevelling machine for the edges of the gears, with CNC control, performs in a single operation what used to take three cycles.

### The Scamp Flexible Workshop

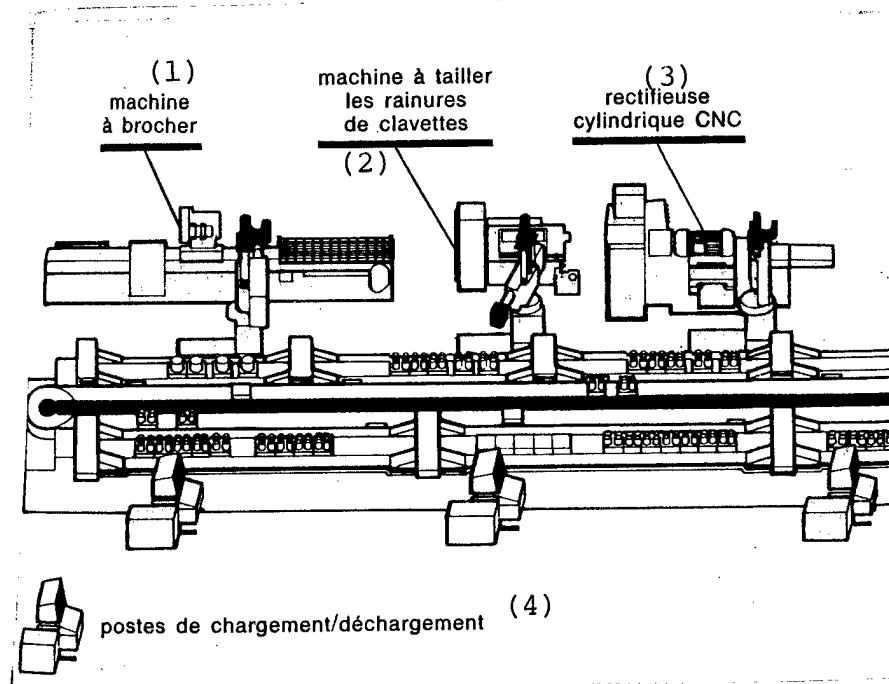

On one side of the three roller-operated conveyor belts are the nine machine-tools with CND control (seven CNC and two conventional machines), supplied by eight industrial robots. On the other side of the belts are the six loading/unloading stations, where the three operators in the shop work.

#### Key:

1. broaching machine
2. machine for cutting slots in cotters
3. CNC cylindrical grinder
4. loading/unloading stations

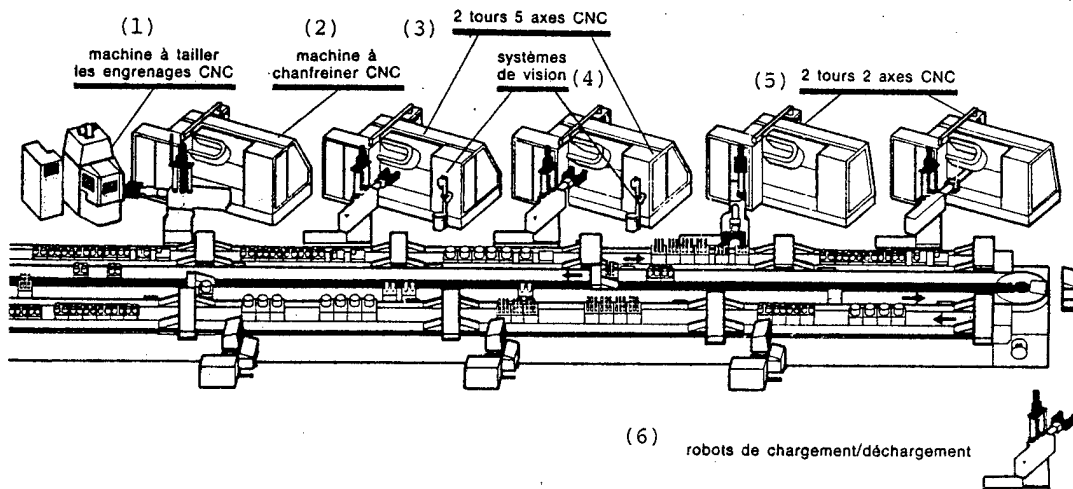

Key:

1. CNC machine for cutting gears
2. CNC beveling machine
3. two CNC five-axis lathes
4. vision systems
5. two CNC two-axis lathes
6. loading/unloading robots

Simple Solutions and No Special Tools

At no time were the concept or design of the parts modified. "We wanted to learn. So we took the problem as it was given to us." What is also striking, when looking at this workshop, is the simplicity of the solutions used: no special tools, which reduce flexibility; the parts are arranged flat on the pallets (crown gears) or placed in a standing position in supporting cavities (shafts). For the robots, a single pincer is used to grasp all the parts.

On one side of the shop are six loading stations with a console, keyboard, and screen. The management computer indicates to the operator (there are three operators) the loading operation to be performed: the shape of the items is shown on the screen,

the number of parts per pallet, the arrangement of the parts on the pallet, and the number of pallets to be loaded. This number of parts per pallet is a very important criterion. "We can't forget that we have small parts and short cycle times, unlike flexible workshop units with machining centers."

In order to avoid jamming the system and to determine carefully the buffer-stocks to be placed between machines, the Cranfield Institute of Technology developed a computer simulation. The system accepts a maximum of 150 pallets, and the total machining time per pallet has been set at an average of half an hour. "That is why you see the operators loading one, four, or 32 different parts on the same type of pallet."

Once the operator has placed the rough forms for the parts, he informs the central computer. The pallets, which have optical reflectors (binary coding) are then recorded with the type and number of parts they carry, and will be followed throughout the system at all times by optical cells placed at the level of the buffer-stocks. The pneumatic guide pushes them one by one on the conveyor supply belt (closed circuit). They automatically go to the buffer-stock of the first machining operation on two Colchester CNC 650 two-axis lathes equipped with Sandvik tool-changing units. The first three pallets are spaced and locked into position so that the robot can grasp the parts without difficulty. The robot is programmed manually by pushing buttons. The programs for the type of part are stored in the workshop's management computer.

The same arrangement is repeated at the third and fourth stations, which have two Colchester CNC 650 five-axis lathes with milling and drilling capabilities. Near these machines are two British Robotic System vision systems managed by a PDP 11/23. "Four of our molded components have a somewhat unusual shape (a projecting section). We didn't want to use special tools to arrange them on the pallets. That is expensive, cumbersome to manage, and not very flexible."

The robot goes to seek these parts on the pallets and places them on a rotating table under a camera. The camera analyzes the image every 3 degrees, locates the projecting part, and transmits the information to the rotating table. The table then provides the robot with a well oriented part which can be loaded for machining. The following stations have a Sykes machine for cutting gears linked directly by a robot to a Sykes machine for grinding and trimming gears. "These are very strict sequences; that is why a robot is used here." In addition, these machines are the weakest link in the chain. "That



is true," said Peter Cook. "We have only a single one of these machines in the shop. But the computer simulation showed us that in case of a breakdown we have enough parts in buffer-storage. Let's say there is a hydraulic failure in this type of equipment. That could stop us for 2 to 3 hours. But we have 20 pallets of parts waiting, which is nearly 10 hours of machining, before the other stations would be blocked."

#### Two Computers Manage the Entire Facility

After this there is a Matrix cylindrical grinder, also with CNC control, with a Heidenhem absolute control system. This is followed by two conventional machines: the Sykes H 160 machine for cutting slots in cotters, and the Clarkson broacher, which are both kept supplied by a robot.

At each station, when a batch of components is finished, the central computer gives new loading instructions on the display screen of the loading station. When one type of fabrication is completed, it indicates to the operator that a new set of tools is needed (tools, mandrels) and sends the new program to the machine-tool and the robot associated with that tool. At the same time, adjustment instructions are given to the operator through the CND link. The operator performs these operations, then allows the cycle to start. For dimensional control, the operator checks the first part. If these are difficult components, a check may be made at every fifth or tenth part. The robot will remove the part from the machine-tool and place it on an outlet station, while at the same time issuing a light signal to the operator.

The entire facility is managed by two Systime Ltd 5000 E computers operating in tandem, based on DEC PDP 11/34 E computers (one computer is used as a relay in case of breakdowns). "It took us 6 months to determine our specifications for the software, written in Fortran," said Peter Cook. "Then, to design and develop this software, it took Systime a year with a team of six people working on this project. It was their first software for a flexible workshop." In all, the facility took 3 years of study for its design, and 12 to 18 months for building the machine-tools. The facility, after the usual problems which arise when getting started, now operates 39 hours a week. During the lunch hour, it operates without surveillance.

A great many improvements still remain to be made. As in many other flexible workshops, the problem of tool breakage has not been solved. "We are working with data on the lifespan

of these tools and making changes. When machining a new batch of parts, we check the condition of the tools. But if a tool breaks, we don't know about it until a later check is made." Fanuc is working on this problem, as are people at Scamp, along with Sandvik and Renishaw. Other projects are related to the automatic corrections of tools on the machine, and continuous monitoring of lubricants used for cutting. "With the Pera Research Center, we want to monitor the pH values of liquids. We want to control all aspects of the flexible workshop. That is one of them!"

The Scamp flexible workshop also demonstrates that it is possible to machine small batches of parts in 3 days, without human intervention, while a conventional machining process takes 50 handling operations spread out over a period of 8 weeks.

#### PHOTO CAPTIONS

1. p 52. The first three pallets of buffer-stocks are spaced and locked into position in order to facilitate the robot's loading/unloading operation. In the center, the two parts of the conveyor belt, moving in a closed circuit.
2. p 53. A loading/unloading station. The display shows the shape of the items to be loaded, the number of parts per pallet, the arrangement on the pallet, and the number of pallets. After validation, the pneumatic guide (to the right of the console) will push the pallets one by one onto the conveyor supply belt.

7679

CSO: 3698/1

## INDUSTRIAL TECHNOLOGY

### BRIEFS

ROBOTS INCREASE BL PRODUCTION--With an investment program of 850 million DM, the British automobile enterprise Austin Rover, which is part of the British Leyland conglomerate, wishes to find its technological-economic place at the world leadership. In the Cowley plant, where the "Maestro" is being built, 116 robots are being installed, and the production rate per employee per year is to rise to 18 per 1984. In 1979 this rate amounted to six, and in 1982 to 14. Productivity will thus achieve Japanese rates, where the quota is about 20. Without strong government support, the enterprise surely would have vanished from the market. Cooperation with Honda yielded new know-how. The mini car Metro became "the first competitive product", according to Harold Musgrove, chairman of the board and director of Austin Rover. However, technology is expensive, as Musgrove well knows. The current principal requirement is supposed to be the large research and development expenditure for small enterprises. With the Maestro, a mass-produced automobile is now receiving plastic bumpers, which can be lacquered together with the body. When the lacquer is burned in, the plastic heats to 135° C. [Text] [Duesseldorf VDI NACHRICHTEN in German 22 Jul 83 p 1] 8348

CSO: 3698/439

## SCIENCE POLICY

### BRIEFS

FRG TECH TRANSFER CONTACT--The University of Bayreuth has set up a contact office for transfer of information in research and technology. It aims at being a communications office for the 60 academic chairs of the university in the area of mathematics and natural sciences and it is intended to assist enterprises in the utilization of data banks. In addition, meetings are planned which will bring together representatives of advanced schools and of industry. The university is also prepared to take over the complete management of the project. [Text] [Wuerzburg ELEKTROTECHNIK in German 18 Mar 83 p 6] 8008

CSO: 3698/4

## TRANSPORTATION

### BRITISH LEYLAND'S ECV-3 EXPERIMENTAL CAR IN ROAD TESTS

Duesseldorf VDI NACHRICHTEN in German 1 Apr 83 p 7

[Article by O. Bon Fersen, "Body Short Waves 138 kg"; For related article see JPRS 83065 No 139 of this series dated 14 Mar 83 pp 37-38 ]

[Text] Since the beginning of the year, the research car by British Leyland has been undergoing road tests. The "energy conservation vehicle ECV-3" is a five passenger sedan of the medium class, whose 1.1 liter three cylinder engine drives the front wheels. The 53 kw power train of aluminum (al) was developed by the engineers in two versions, as a carburetor engine and as a torque-optimized fuel-injection engine. The car weighs 664 kg and has a cell skeleton made of aluminum sheet. The non-supporting external covering is made of glass-fiber-reinforced plastic parts. The research car has a speed of 160 km/h and, in driving condition for road traffic, has an air resistance coefficient ( $c_w$ ) of 0.25.

A series of articles last year presented the research cars of the European automobile industry. At the turn of the year 1982/83, one of these was the "energy conservation vehicle ECV-3", from the British Leyland conglomerate. This involves a five passenger sedan of the size class of the Ford Escort/Opel Ascona, whose 3-cylinder auto engine drives the front wheels.

As the number indicates, ECV-3 has two predecessors. Work on the ECV-3 was started in 1978. This research vehicle is a completely new design, which has surpassed every link to the ECV-1 and 2 as well as two models of present mass production. However, some of its details are clearly related to the new Maestro construction series, which celebrated its premiere in March.

"Big inside, compact outside": This guiding principle, which has been taken up with the mini-concept for a quarter of a century, also stands at the center point of the specification manual for the ECV-3 design. The other orientation points concern, among other things, the maximum speed of at least 160 km/h, acceleration times below 12 seconds from stop to 96 km/h (60 mph), and a reduction of fuel consumption in comparison to the "class average" by at least 60 percent. To this are added requirements for clear improvements in passive safety, in driving and noise convenience, corrosion protection, and maintenance requirements. An average five passenger medium class car weighing about 1000 kg with an air resistance coefficient

( $c_w$ ) of 0.40, an engine of 1.6 liters displacement, and about 60 kw power was used as a "comparison basis". The engineers set as their objective to reach the features indicated in the specifications by lowering the weight to 670 kg, the air resistance coefficient to  $c_w$  0.27, and the engine displacement to 1.1 liters.

Accordingly, the three paths were: reduction of empty weight; aerodynamic optimization of the shape, and improvement of the efficiency of the unit.

The design of the body was developed by means of the finite element method and other computer-supported studies. Thus, a supporting and essentially torsion-resistant skeleton was created, which consisted of aluminum sheet metal joined together by welding and predominantly by gluing. It has a non-supporting external cover, whose shells consist of glass fiber-reinforced polyurethane (RRIMPU = reinforced reaction injection molding polyurethane). Glass fiber-reinforced polyester (SMC = sheet molding compound) was selected for the engine hood and the interior shell of the rear door. Austin/Rover had such a vehicle structure already earlier on (Rover 2000)--although it used different materials.

#### Lessons from the Wind Tunnel

The roof is part of the light metal cage. Its center section and the reinforced lateral edges are covered at their connection points by a plastic strip which simultaneously serves as a (flush) rain gutter. The glass parts are also inserted flush into the external cover. The front and rear panes were glued in, likewise the lateral glass parts. In order to save weight, these are only 2.1 mm thick. Only the halves of the four door panes, which adjoin the B-column, can be lowered. Thus the complete body shell with the side and rear doors but without glass weighs a total of 138 kg.

The engine weight was reduced by designing the cylinder block and cylinder head of light metal, with a total weight of 84 kg. However, according to the view of the engineers from British Leyland, a few kilograms can still be saved here. Light-metal wheels with flush compound disks made of plastics and light-running tires yielded a saving of 33 kg compared to the mass-production designs.

Work on the body began with detailed form studies on models. Besides the five-door slant-rear sedan, which was decided upon at the end, square back variants were also investigated. The models here achieved  $c_w$  values up to 0.22. When working in the wind tunnel, it appeared that the limit was about 0.30 for models with an optimized shape but a conventional underfloor. A completely flat floor, however, also does not solve the problem satisfactorily because, in that case, there are disadvantages as regards weight, ground clearance, heat dissipation at the exhaust system, accessibility, and costs. The final development of the body for the ECV-3 therefore began with the floor group. A front spoiler was here dispensed with, and the air at the vehicle bottom was allowed to flow as non-turbulently as possible. The completely equipped car--meaning equipped according to the road vehicle approval ordinance--finally reached a  $c_w$  of 0.25. When the cooling air entry was closed (under thermostatic control), this was improved by another 0.01.

The three-cylinder aluminum engine was derived from the design of the "E-type", such as had been developed for the "Maxi" and "Allegro" models, models which in the meantime have been dropped. Not much more remained from this "basis", however, than the dimensions for the cylinder spacings: 76.2 mm borings and an 81.3 mm stroke yield a displacement of 1113 cm<sup>3</sup>. The crankshaft has multiple bearings, the camshaft in the cylinder head is driven through a simple roller chain. In the course of further development, this will probably give way to a toothed belt. As the result of development work, the best compromise for performance, consumption, and emission turned out to be a gabled roof shape with relatively steeply angled pairs of inlet and outlet valves. These are activated by the camshaft through rocker levers.

Other details are low-weight connecting rods and easy-running low-weight pistons. Two versions of the motor design were developed. While they differed in character, they deliver practically the same final power of 53 kw: a carburetor engine with a compression ratio 10.5 which reaches its rated power at an rpm at 5800, and a "torque-optimized" fuel-injection engine, which makes do with a compression of 9.0 : 1 at 5500 rpm. The development of the engine is presently in no way concluded. Tests are running with "econoguide" easy-running pistons, slide bearings with a reduced friction surface, thrust shut-off, anti-knock regulation, matching of the intake and exhaust pipe, and variable valve control.

Originally, it was intended to use a continuously variable transmission to transmit the power. Development work on such a unit has already been in progress for some time at BL. Here, however, preference was given to a design that was intended for commercial vehicles. In the meantime, a similar collaboration agreement exists between BL and VW for transmission development as exists between VW and Renault. It is no secret that the BL medium-type Maestro is equipped with a four- or five-speed transmission from VW. For the E-engine there indeed is a good five-speed transmission of inhouse production, but this could be used neither for the ECV-3 nor for the maestro because it is located under the engine and thus yields too large a construction height for the streamlined forward car. The three-cylinder engine of the ECV-3 fulfills the emission standard ECE 15/04, which is supposed to become effective in Europe by the end of 1984.

For the present spectrum of front-drive models from Austin, from the Mini to the Princess, the same chassis concept was always used: transverse-link pairs for the front wheels and an individual control at the longitudinal cranks at the rear in combination with special suspension elements of rubber, or air springs in an hydro-pneumatic system.

#### The Stated Objectives were Reached

BL has now abandoned this path with the ECV-3 as also with the Maestro. The new line resembles the solutions that were chosen, for example, by VW and Opel (Cadet and Ascona): Macpherson struts in the front and a compound control axle in the rear. The latter, however, is in principle nothing but a pair of crank arms connected by a "transverse stabilizer". A low empty weight and a high loadability, however, are not readily compatible with a conventional suspension system. In the front, the usual helical springs remained, but for the rear wheels, the "nivomat"

system by Boge was adapted here--not as a supplementary suspension medium but as the only one.

A study of the specification manual for the research car reveals that the very high objectives for the ECV-3 has been fulfilled without exception. Instead of the required maximum speed of 160 km/h a maximum of 184 km/h was measured during measurement runs at the test field in Gaydon. The acceleration time from stop to 60 mph (96 km/h) on the average yielded 11 seconds, and 160 km/h was reached in 35 seconds. The actual empty weight was 6 kg less than target weight of 670 kg. With consumption measurements at 100 km, according to ECE/DIN, the following results were obtained: city cycle 5.76 l; 120 km/h constant 4.63 l, and 90 km/h constant 3.48 l. At a constant speed of 30 mph (48.3 km/h), fuel consumption was 2.2 l/100 km, and at constant speed at 160 km/h it was 7.06 l per 100 km.

The optimization of the research car was coupled with driving tests. It began at the turn of the year 1982/83. A number of essential developments, especially in connection with the power unit, is still in its infancy.

8348

CSO: 3698/439



## TRANSPORTATION

FRG STATE, INDUSTRY SHARE RISING COSTS OF AIRBUS VENTURE

Duesseldorf WIRTSCHAFTSWOCHE in German 16 Sep 83 pp 20-22

[Article: "Morsels for the State Treasury"]

[Text] Participation in the European Airbus program is getting to be more and more expensive for the German treasury: Direct subsidies alone have risen to DM7.4 billion. Even more fraught with risks than the program so far is the plan to market a smaller model, the A-320.

CSU [Christian Social Union] boss Franz Josef Strauss, who wears two hats as Bavarian prime minister and as chairman of the board of directors of the German Airbus GmbH [Inc.], reminded Chancellor Helmut Kohl in writing of the content of the coalition talks: Even then he, Strauss, in talking to Economy Minister Count Otto Lambsdorff, "expressed the conviction that the airbus project should be continued either by offering new aircraft or that it has no chance of survival in the long run." A "no" from Bonn regarding the expansion of the Airbus program--according to Strauss--would have bad consequences: "There would then be no benefit at all--no benefit that would be greater than the damage."

The CSU politician pushed a prestige project which became the most expensive industrial undertaking financed by the West German government. Even without the new aircraft type which Strauss wants, the federal government must, according to the latest status of the program, pay DM7.4 billion in direct subsidies (see Table and box). Besides, the federal government is liable as the guarantor for production and export loans amounting to more than DM10 billion. In this way alone the German share out of the European civilian jet program is far more expensive for the government treasury than the fast breeder which has been so vehemently discussed in public, and it is also more expensive than the steel industry which is in the midst of a crisis. The costs and thus also the doubts about the undertaking's economic success keep growing with each new program correction. Even if the economic situation should improve on the aircraft market, the Airbuses--which were developed almost exclusively at government expense and which are undeniably distinguished by modern technology--can be sold only with government subsidies well into the 1990's.

The letter from Munich was carefully worded. At this time, Economy Minister Lambsdorff and Federal Finance Minister Gerhard Stoltenberg are preparing a

federal cabinet meeting for the end of this month or the start of the next month during which decisions are to be made on subsidy payments that are due and on boosting the guarantee framework; there is also supposed to be a debate on the Airbus industry's plan to broaden its supply by means of a smaller A-320 model.

Nobody in Bonn is thinking of stopping the program because that would mean the loss of 10,000 jobs in Hamburg and Bremen alone. During the election campaign in Bremen, Chancellor Kohl declared that the preservation of the civilian aircraft industry is a "national task."

Just how desolate the Airbus situation is was disclosed in a cabinet proposal which was declared to be classified. Skepticism toward permanent subsidies was justified even before that but the situation deteriorated further with the start of the worldwide transport aircraft sales crisis in 1981. In 1982, only 17 aircraft (1981, 46) were ordered from the Airbus industry and only four orders were obtained in 1983. Besides, out of the 17 aircraft ordered in 1982, 12 orders are not backed up according to documents held by the ministries in Bonn or cannot be carried out. Moreover, 11 previously ordered aircraft were cancelled in 1982 and 51 options were not converted into firm orders.

Originally, AI (Airbus Industry) wanted to increase the output to 88 aircraft per year. In spite of the gradual reduction in the annual output down to only 45 jets per year in 1985, which is now being contemplated and which must yet get the blessing of the board of directors in the fall, more and more Airbuses are being assembled for the storage area; in 1984, the storage area is to reach its greatest size with 29 ready but not yet sold aircraft. On top of that there is a "base inventory" which has been increased to 10 aircraft because the time between the first flight and delivery to the particular airline company is no longer one month as before but rather 2 months.

Only if sales on the world market pick up in 1985, as is being hoped, can the expensive aircraft storage area once again be reduced. According to preliminary planning, communicated to Bonn by the German Airbus GmbH, production is to be increased again a year later--although, of course, only to a maximum of 66 aircraft in 1988-1990. The sales figures of 860 jets, contemplated for the entire program, is now to be reached in 1994, 2 years later than according to the planning which was updated for the last time in 1981. The aircraft builders hope that they would reach the point in 1994 where sales proceeds would suffice to pay back all of the loans taken out for production. But development and improvement costs as well sales financing assistance would not be included in that.

Along with the latest production planning, the German Airbus builders also submitted a revised calculation with which the increased financing requirement is being justified. Accordingly, they propose additional expenditures of DM3.450 billion, compared to the estimate they had come up with 2 years earlier, including DM801 for loan interest. The ready-aircraft storage area and the increased base inventory will gobble up additional interest payments of DM439 million. And the costs have to be taken care of faster than the additional earnings of DM3.334 billion which it is hoped will spring from the fact that the program is to be stretched out in terms of time.

The international aircraft market is a dollar market and the competition-- Boeing--is assembling its aircraft in the United States; that makes it possible, in spite of temporary price reductions, to raise the sales proceeds considerably higher than had been planned until now. Thus, the upward evaluation of the dollar, which was included in the Airbus calculation, gives the German aircraft builders additional revenues of DM1.5 billion until 1994--on paper.

And because costs in United States aircraft construction so far have been climbing faster and because, according to Airbus calculations, they will continue to rise faster than in West Germany until 1985, the German Airbus people are figuring on an additional earning advantage of DM2.783 billion. The old program figures on keeping up with wage and materials price rises already starting in 1983.

But the Munich jet calculators also took into consideration revenue decreases, above all as the result of a change in the type mix within the assumed sales figure of 860 aircraft. In view of the worldwide trend toward smaller aircraft, they figured that less large Airbuses of types A-300 and A-300-600 would be sold but that, in turn, more aircraft of the smaller A-310 type would be sold. Of course, the A-310 will have to assert itself against American competition.

This calculation also includes rationalizations and efficiency increases in production. Back in 1981 already however a McKinsey company consultant outfit discovered that the current applicable operation-cost return principles, along with the maximum limit and together with the actual ban on profits, does not offer adequate incentives for rationalization measures. This is why Lamsdorff and Stoltenberg want to urge that a fixed-price system be agreed upon as quickly as possible. An intermediate stage is being negotiated because of the difficulties in price fixing: A maximum price with a cost reduction bonus is to be agreed upon in the future. The savings are to be shared among those involved.

Nevertheless, the calculation does contain certain risks which could also wipe out the new calculations. Looking at it this way, the German Airbus managers assume that they will get their loans--starting in 1984 and up to the end of the program--at an average interest rate of 7 percent. But if these expectations do not materialize, then the federal government will have to bear the risk by having to assume higher guarantees.

Another thing that is questionable is whether Airbus will again be able in 1986 to raise its prices for the A-300-600 which can currently be obtained only with certain reductions. And it is certain that the ceiling of DM4 million, for sales financing assistance per aircraft, cannot be maintained if the interest subsidies must be raised because of the competition's more favorable financing terms.

Another danger point consists of the manufacturer's warranties. Because of the money shortage faced by many airline companies, banks in some cases demand as indemnity guarantees from Airbus for export loans beyond the government export credit guarantee. As it told ministry officials in Bonn, DA (German Airbus, Inc.) is figuring on manufacturer warranties totalling DM1.92 billion.

According to its estimates, this figure will actually be taken up from the banks to the extent of 480 million. But if the indemnity payments keep rising because of the fact that the clients are having growing payment difficulties, then Airbus itself will have to take out additional loans which the federal government will have to guarantee. This, at most, would mean an additional DM1.44 billion.

This is the background against which the federal cabinet will debate the plan submitted by Airbus Industry to expand its program family by adding the completely newly developed type A-320 with 150 seats. But while it is above all the French who keep pushing, the people in Bonn are still rather reluctant. According to their data, with a German share of 35.2 percent, German industry would still be facing basic development costs of DM1.3 billion and 400 million for additional improvements. The guarantee volume would thus rise by DM1.25 billion as a result of the A-320. The funds for sales financing--assuming present-day capital market conditions--will come to about half of the current program.

The Airbus managers have already reported their rather expensive wishes by way of precaution. The industry could only come up with 10 percent of the development costs and, looking at the guarantees, likewise, the federal government would have to be satisfied with a lower backbond.

In March of last year already the West German administration at that time declared that, as far as it was concerned, participation in the program expansion would be considered only if its economy had been proven. Customer orders would represent this kind of evidence--but those are still only coming from France (see WIRTSCHAFTSWOCHE, 37, 1983).

According to the expensive lessons learned in the development of the program so far, it would seem to be justified to doubt that the A-320 could ever become an economic success and could ever be sold at least cost-covering prices. In contrast to the A-300 and A-300-600 types--which did push into a market vacuum--the A-320 is completely aimed at those markets that are being dominated by the American competition.

In view of this starting situation, ministry officials have hatched a plan for the distribution of the burdens in preparation of the new cabinet decision: The federal government is to guarantee only 75 percent of the entire financing requirement for development and production; industry will be fully responsible for the remaining 25 percent. During its Airbus session, the Bonn cabinet must decide whether it will participate in the preparatory development work for the A-320 with a onetime, conditionally repayable subsidy of DM12 million--a mere pittance in view of the sums which Airbus customarily deals with.

Billions at Government Expense  
 Federal Government Payments for the Current Airbus Program until 1994 (in billions of DM)

|  | <u>Subsidies accord-</u><br><u>ing to past</u><br><u>cabinet decisions</u> | <u>Including</u><br><u>amounts</u><br><u>paid out</u> | <u>Addi-</u><br><u>tional</u><br><u>promises</u> | <u>Sum</u> |
|--|--|---|--|------------|
| Development cost subsidies<br>(including about 130 million repaid) | 2.319  | 2.127   | 0.238  | 2.552      |
| Production assistance  | 0.642  | 0.642   | --   | 0.642      |
| Sales financing assistance   | 2.044  | 0.304   | 2.140  | 4.184      |
| Total  | 5.000  | 3.073   | 2.379  | 7.378      |

Federal Government as Guarantor

The economic risk involved in the development, production, and sale of the Airbus wide-body jets was shifted almost entirely to the government in the contracts signed between German industry and the West German government. The German share (37.9 percent) out of the European Airbus Program is being handled by DA in Munich, an affiliate of MBB (Messerschmitt-Boelkow-Blohm) which supplies the German structural components and which it bills to the government via DA. The government guarantees the Airbus program in many ways.

Out of the development costs, the industry carries a maximum of 15 percent; the rest is being paid out of the federal treasury (see table) as a conditionally repayable subsidy. These amounts are to be repaid only if profits are made with Airbus and after all loss carryovers have been settled. Development promotion also includes the costs for the improvement of the A-300 basic model. Additional new development cost subsidies have currently been requested, above all for improvements in the "small Airbus," that is, the A-310--in the amount of DM238 million.

The federal government fully secures the financing requirement for current series production through the "series guarantee." Because of foreseeable price rises, the guarantee framework--which only in 1982 was raised from DM2.85 billion to DM4.1 billion--must be boosted to DM4.5 billion in the coming cabinet decision. According to the new program planned, the government-guaranteed loans are to be paid back by 1994. If the industry cannot pay the loans back according to plan, the federal government must make up for the difference from its own money. The industry is liable to the federal government only to the extent of 25-percent backbond--with a further restriction through an insolvency clause: The countersecurity is not to be claimed by the federal government if that would threaten the enterprise's continued existence.

The federal government supports sales through sales financing assistance; It takes over the guarantees for export credit insurance and pays interest subsidies.

The limitation on sales assistance to a figure of DM6 million until 1985, respectively, DM4 million starting in 1986 per aircraft, which was introduced through the March 1982 cabinet resolution, is to be retained for the time being.

Bonn secures export loans for the sale of the Airbus through export credit guarantees. The federal government currently has undertaken export guarantees for about 180 insured aircraft to the tune of DM6 billion. Because of the "special technological and employment-policy interest," in Airbus exports, the federal government, according to the cabinet draft, "wants to examine carefully whether, in the individual case, the assumption of a higher risk than usual would be justified."

5058

CSO: 3698/448

END