

243119

JPRS-JST-88-015

3 AUGUST 1988

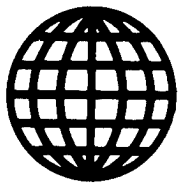

**FOREIGN  
BROADCAST  
INFORMATION  
SERVICE**

# ***JPRS Report***

**DISTRIBUTION STATEMENT A**

Approved for public release;  
Distribution Unlimited

# **Science & Technology**

***Japan***

19980612 040

REPRODUCED BY  
NATIONAL TECHNICAL  
INFORMATION SERVICE  
U.S. DEPARTMENT OF COMMERCE  
SPRINGFIELD, VA. 22161

DTIC QUALITY INSPECTED 6

10  
112  
A06

SCIENCE & TECHNOLOGY

JAPAN

CONTENTS

AEROSPACE, CIVIL AVIATION

Development of New Spaceplane	
Winged Collection Plane [PUROMETEUSU, Feb 88] .....	1
Space Plane Project [PUROMETEUSU, Feb 88] .....	7
National Aerospace Laboratory News Update	
[KOGIKEN NYUSU, Feb 88] .....	16
Operational Performance of Engine on Fan Jet STOL Asuka	
[KOGIKEN NYUSU, Feb 88] .....	19
National Aerospace Laboratory's 10 Cm x 10 Cm Magnetic Support	
Balance for Holding Models in Wind Tunnels	
[KOGIKEN NYUSU, Feb 88] .....	22
Aerodynamic Testing of ACT All-plane Elastic Model	
[KOGIKEN NYUSU, Feb 88] .....	26
Japan To Build Manned Space Platform	
[KYODO, 21 May 88] .....	28
Space Station Envisages Artificial Gravity	
[Tim Johnson; KYODO, 24 May 88] .....	30
Space Agency Cites Progress on Japanese Shuttle	
[Tim Johnson; KYODO, 26 May 88] .....	32

BIOTECHNOLOGY

Bioreactor, Biosensor Technology Discussed  
[IMMOBILIZATION OF MICROORGANISM/ENZYME and BIOSENSOR,  
Mar 88] ..... 34

COMPUTERS

Information Project/FY88/MITI  
[Motoya Nakae; DENSHI KOGYO GEPP0, Feb 88] ..... 44

NUCLEAR ENGINEERING

JT-60 Tokamak Type Test Device Test Results  
[GENSHIRYOKU IINKAI GEPP0, No 374, Feb 88] ..... 66

Agreement Reached on Joint Low Level Waste Research  
[GENSHIRYOKU SANGYO SHIMBUN, 4 Feb 88] ..... 72

Advanced Reactor Design System To Be Developed  
[GENSHIRYOKU SANGYO SHIMBUN, 4 Feb 88] ..... 73

Functional Testing on "Mutsu" Scheduled  
[GENSHIRYOKU SANGYO SHIMBUN, 4 Feb 88] ..... 75

Shimizu Construction Establishes New Departments  
[GENSHIRYOKU SANGYO SHIMBUN, 4 Feb 88] ..... 76

Nuclear Power Generation Plant Utilization Rate Hits 72 Percent  
[GENSHIRYOKU SANGYO SHIMBUN, 4 Feb 88] ..... 77

TELECOMMUNICATIONS

Telecommunications Terminal System Discussed  
[Takahiro Kawazoe; JIDOSHA GIJUTSU, Feb 88] ..... 81

Development of Hand-Free Mobile Phone Reported  
[Nobuyuki Ishihara, Takuo Yamamoto; JIDOSHA GIJUTSU, Feb 88] ..... 99

/9986

Development of New Spaceplane

**Winged Collection Plane**

43062556 Tokyo PUROMETEUSU in Japanese Feb 88 pp 42-45

[Article by R&D Planning Section, Planning Administration Department, National Space Development Agency]

[Text] The National Space Development Agency (NASDA) is conducting research on a winged collection plane called "HOPE" (H-II Rocket Orbiting Plane) that is to be launched by the H-II rocket also currently under development. NASDA wants to use HOPE to collect information and material obtained by the space station and return them to earth as soon as possible. NASDA would like to complete HOPE about the time a space station becomes operational and expects to use HOPE to establish the basic technology for the future space plane.

The technical development of a collection plane has become possible thanks to the results of almost 10 years of research on heat-resistant materials and recent progress in the development of the H-II rocket. This research has been accelerated and focused on the HOPE concept because the need to be able to collect information and materials from orbit has become concrete with the progress of the space station project.

The HOPE concept is still in the formative stage. The following items are being concretely examined as elements of its basic concept:

1. Transport the collected cargoes from the space station as soon as possible.
2. Vertical launch by the H-II rocket.
3. Unmanned operation by remote control from earth.
4. Automatic landing on a runway.
5. Make it reusable and establish a basic technology for the future development of space planes.

## Flight Profile

HOPE is to be launched vertically from the Tanegashima Space Center mounted on the H-II rocket.

HOPE will be lifted into a parking orbit at an altitude of about 200 km. From there, as shown in Figure 1, it will rendezvous and dock with the space station. It will deorbit after loading and unloading cargoes at the space station; it will reenter the atmosphere and complete its space flight after making an automatic runway landing. About 100 hours (4 days) will be scheduled for the flight time from launching to landing. A somewhat more detailed explanation will be given below.

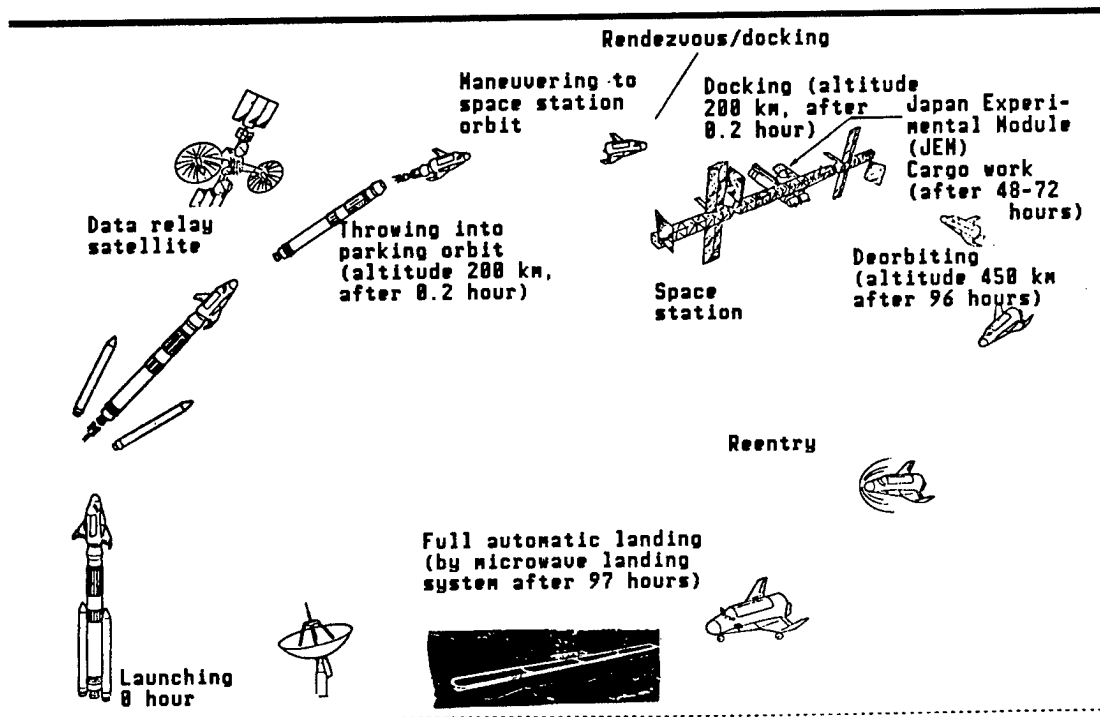

Figure 1. Flight Plan Chart for HOPE

The H-II rocket that will launch HOPE is the same one to be used for launching ordinary satellites. However, HOPE will be fixed directly to the top of the rocket and additional measures will be taken, such as adding stabilizing wings to the first stage of the rocket to ensure flight stabilization at the time of liftoff.

As in the case of ordinary satellite launchings, the H-II rocket will be launched from the H-II launching ramp that is now under construction. After completing preparation at the launching site, the H-II will lift HOPE into its parking orbit at an altitude of about 200 km about 12 minutes after launching.

Once HOPE has reached its parking orbit at an altitude of about 200 km, it will have to wait for a period before it can rendezvous with the space

station, which will be flying at an altitude of about 450 km. This waiting time is calculated to be a maximum of 50 hours (about 2 days). The waiting time will, of course, be shorter if HOPE's orbit can be aligned with the flying position of the space station through good launch timing and effective guidance of the rocket. But since this is based on untried technology, for Japan, the plan has a little margin built in.

HOPE will approach the space station to a distance of several 10 km by adjusting its orbit using good timing. Then it will proceed to a point several meters from the space station to begin the rendezvous operation by using a rendezvous radar, etc. It will dock with the station after confirming this can be done safely.

It is anticipated that the loading and unloading of cargoes from HOPE will be done by the manipulator arm of the space station. It would be rational for the cargoes for HOPE to be made to fit a standard rack (mass is about 600 kg in 1 m x 1 m x 1.8 m) container for convenience in moving or fixing them in the space station. It is expected that 1 day (about 24 hours) will be required to load and unload the cargoes.

It is also necessary for HOPE to have good timing in leaving orbit to return to earth from the space station. HOPE must leave its orbit when its landing site is within the scope of its gliding capability. It is estimated that HOPE will have to wait in orbit for a day so that its gliding capability and the location of the landing site can be adjusted. If this is done properly, HOPE should have at least one reentry window a day.

After leaving orbit, HOPE will reenter the atmosphere and circle around half of the earth. HOPE will experience maximum temperatures close to 170°C at this time due to the friction with the air and its communication with the ground will be lost. This is because radiowaves are cut off when the air around the body of the craft becomes a plasma. It is estimated that this blackout will occur at an altitude of about 80 to 60 km.

When reentering the atmosphere, HOPE is braked by air resistance. Its maximum deceleration will be about 3G, which is a "soft reentry" that the living body and ordinary men can stand. Deceleration can become very large, about 8G, in the case of a capsule-type craft like the Apollo, which is not suited to the living bodies of ordinary men. However, a winged craft like HOPE returns to the earth with a soft deceleration by gliding in the atmosphere.

HOPE will have a complicated guidance control to ensure that even during the blackout at the time of reentry into the atmosphere the soft deceleration and the flight to the landing field will be maintained.

Communication is recovered at a point several hundred meters from the landing site and HOPE will arrive at the landing site after about 30 minutes of gliding. During this period it will fly at a comparatively large rate of descent from an altitude of 30 km to 3 km. From that point it will fly at a rate of descent similar to that of an ordinary aircraft.

Finally, it will automatically land on the runway at a speed of about 300 km/h.

### Configuration of HOPE

The configuration of HOPE must be such that it can fulfill its primary flight performance task of returning to the earth in addition to being able to withstand various flight environments from launching into orbit by the H-II rocket to reentering the atmosphere for a safe landing after making space flight. Since HOPE is to be mounted atop the H-II rocket, not only can it not be made too large because it must fit within the controlling capacity of the rocket, but its maximum mass cannot exceed 10 tons. It is also highly possible that the overall breadth of the body will have to be less than 10 meters.

Although the optimum size and shape of the body is currently under study, it is thought that the shape will be roughly that shown in Figure 2. The characteristics of the external shape of this body are a relatively big fuselage, delta wings at a large sweptback angle, and two vertical tail planes.

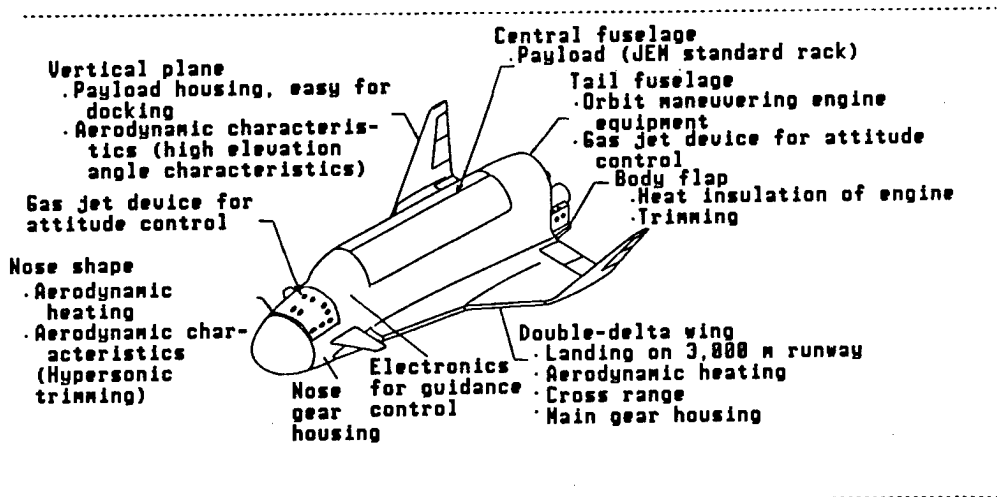

Figure 2. Configuration of HOPE (draft)

The large fuselage is designed not only to house the cargo but also to suppress the rise in temperature experienced by the nose section due to the aerodynamic heating at the time of reentry. The large sweptback delta wing is designed to obtain the aerodynamic stability and the lift required for gliding with a small wing area during the entire course of its flight from the hypersonic flight at the time of landing. The reason the vertical tail planes are placed at both sides of the main wings is to ensure that they do not become obstacles when docking a small body like HOPE at the space station. Although it is a little disadvantageous structurally, it can be expected to provide an advantageous performance aerodynamically.

The cargo room will be located in the center of HOPE's fuselage. The nose section will mainly house the guidance- and control-related equipment and the nose gear. The orbit maneuvering engine, the gas jet device for attitude control, etc., will be housed in the rear part. The main landing gear and the actuator of the aerodynamic balance will be housed in the main wings.

The surface of the body will be covered with heat-resistant material to protect against the high temperatures experienced at the time of reentry into the atmosphere. Carbon/carbon heat-resistant material for ultrahigh temperatures will be used for the nose section and the leading edges. Ceramic tiles or a high-performance metallic heat-resistant material will be used for the high temperature section of the under surfaces of the fuselage and wings.

The size of the body will be less than 20 m. This is quite small compared to that of the space shuttle, but since the function of returning to earth from space is the same, it has much equipment and the amount of cargo cannot be made too big--about 10 to 20 percent of the whole.

It must be taken into consideration in developing the body of HOPE that there is a tendency for the temperature rise due to aerodynamic heating at the time of reentry into the atmosphere to become large because of the craft's small size. It is, therefore, necessary to take countermeasures such as making the corner and fillet radii of the nose and leading edges big, making the reentry course gentle, or using a high-performance heat-resistant material. It is also necessary to have good gliding performance and a margin of stability in the low-speed zone at the time of landing in addition to having to cope with the aerodynamic conditions in the hypersonic zone.

Technology to protect against aerodynamic heating and to ensure gliding performance from hypersonic to low speeds is a new field for Japan. Therefore, it is necessary to conduct a sure technological development by using various flight experiments in addition to windtunnel tests and numerical analysis by the most recently developed computers.

### **Essential Technology**

In the development of HOPE, the following technologies in particular must be developed newly and preferentially in addition to the technology Japan has so far accumulated in its space development program:

1. Heat resistance/structure technology to counter the high temperatures experienced at the time of reentry;
2. guidance control technology that can ensure guidance at the time of reentry, automatic landing, and rendezvous/docking;
3. hypersonic flight technology including aerodynamic heating;
4. large-capacity electric power technology including the fuel cell; and



## 5. orbit maneuvering engine technology.

As for thermal structure technology, good test results have been obtained from carbon/carbon heat-resistant materials that can withstand temperatures up to 1,700°C, a light ceramic tile capable of enduring temperatures up to 1,200°C, and soft heat-resistant materials able to withstand up to 6,700°C. Basic research has been conducted in this area for nearly 10 years, even if on a small scale. Research into a metallic heat-resistant material with greater reusability is also being advanced. As for a main structural material to support the load, research is being conducted on new materials, such as graphite/polymide, with the goal of finding a light composite material that can take the place of the conventional aluminum alloy.

Although rocket guidance control and satellite attitude control technologies will serve as the bases for the guidance control technology, a new line of research is needed to explore reentry guidance and automatic landing. Good results have been obtained on a remote control rendezvous system. This represents the results of research preferentially advanced on the rendezvous/docking sequences, even if on a small scale. Further, research on the test manufacture of rendezvous radars, etc., is being advanced.

Meanwhile, with regard to aerodynamic performance, research is being advanced using computer analysis in addition to obtaining data by conducting various wind tunnel tests together with studies of the body.

The electric power required by HOPE totals several hundred kW/h, but since no solar cells can be used and since the conventional batteries used for rockets or satellites are too heavy, it is necessary to develop fuel cells. Therefore, the investigation and examination of ways to develop fuel cells are underway.

Although the development of HOPE is still in the stage of solidifying its concept, the research project has been advanced by establishing the "HOPE Technology Committee" in NASDA in addition to conducting joint research and information exchanges with related organizations, including the National Aerospace Laboratory.

We would like to direct our efforts toward the earliest possible realization of HOPE by further advancing research so that HOPE can become fully operational at the same time as the space station. This will require an effective development plan backed by an adequate budget.

## Space Plane Project

43062556 Tokyo PUROMETEUSU in Japanese Feb 88 pp 46-51

[Article by the National Aerospace Laboratory, Science and Technology Agency]

### [Text] 1. Foreword

In May 1987, the long-term policy meeting of the Space Development Committee issued a report entitled "Aiming at the New Era of Space Development." This report proposes a long-term policy for the next 20 years. While aiming at the 21st century, it is based on the 20-year history of space development in Japan.

This highly motivated report states: "By the efforts made within this century, Japan will aim to take a central role in worldwide space development at the beginning of the 21st century." It will be necessary to successfully achieve various large-scale technical developments to realize this goal.

Japan's own evolution of manned space activities and the creation of a space infrastructure for a permanent facility for space activities is the target for the beginning of the 21st century, to say nothing of the expansion of scientific probing, communication, and earth observation.

A manned space plane that can take off and land horizontally is considered to be one of the most important aspects of this space infrastructure. A very high degree of technical development will be required to produce such a vehicle. The Space Plane Study Meeting, established as an advisory organ to the director of the Research and Development Bureau of the Science and Technology Agency, has examined the positioning of this space plane as a space transport system together with its basic policy. This article will explain the direction of technological development and the R&D of this space plane based on the results of this examination.

### 2. Basic Policy for R&D of a Space Plane (Study Meeting Report)

The members of the Space Plane Study Meeting are knowledgeable individuals drawn from universities, research institutes, manufacturers, etc. It is chaired by Professor Shigeo Kobayashi of Tokyo University. It began its work at the end of 1986 and submitted its completed report to the director of the R&D Bureau. The report supports the buildup of a space shuttle transport system aimed at promoting manned space activity and the preparation of a space infrastructure. The contents are summarized as follows:

1) A future space transport system should be divided into two functional areas: cargo, with the emphasis on economy, and man, where safety is the primary concern.

2) For the space plane to be a safe and reliable manned space shuttle, it must be capable of horizontal take-off and landing based on aeronautical technology.

3) A high-speed, aerodynamic, lightweight, heat-resistant structure; innovative control; manned operation; and propulsion technologies are all necessary. These will require a very high degree of technical development.

4) Research and development must be advanced in the three stages of planning, experiment, and verification.

5) In the planning stage, which will last for several years for now, the development of the space plane must be advanced through close mutual cooperation among the National Aerospace Laboratory, the National Space Science Laboratory, NASDA, and nuclear R&D organizations based on their present related research work.

6) A large-scale R&D program must be advanced centering on the verification of various essential technologies, including an air-breathing engine, by experimental planes at the stage of experiment and verification before technical development becomes full-scale.

7) A prototype of the space plane must be started in the development stage.

Figure 1 shows the basic concept of the R&D plan that is scheduled to be carried out over a period of about 20 years. It is a large-scale project that is expected to cost about ¥2 trillion.

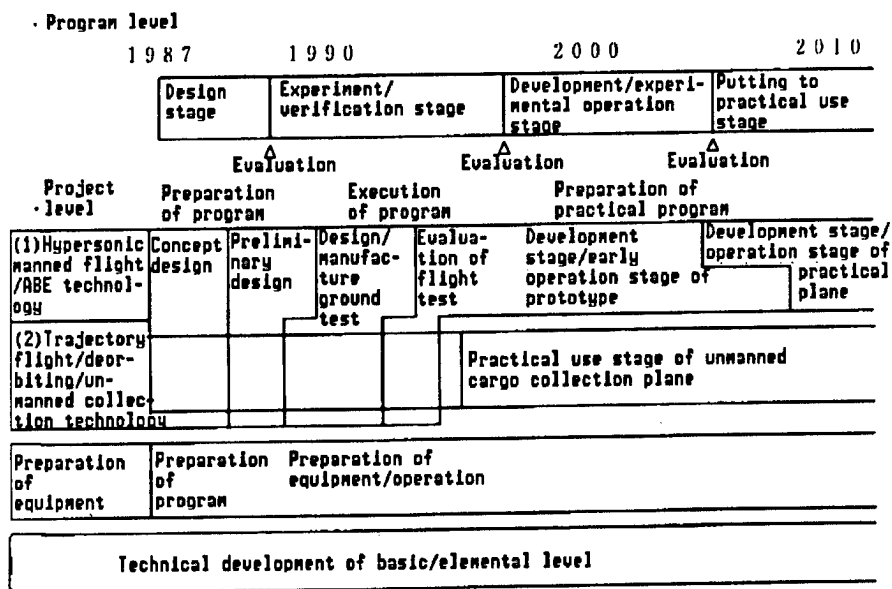

Figure 1. R&D Flow of Space Plane of Japan

### 3. Space Plane Technology

A space plane is a craft that takes off horizontally like an aircraft, accelerates in the air, and after completing its assigned tasks reaches a space orbit. It flies like an aircraft again on reentering the atmosphere and makes horizontal landing at an airport. It is easy to say that it will go to space by flying like an aircraft, but this, in fact, requires a big jump in technology. At present, all space transport systems are launched vertically by booster rockets. The multistage rocket is the only technology presently capable of obtaining a velocity of about 7.9 km/sec, which is the minimum speed required to reach space. The rocket never utilizes the existence of air to reach space.

By contrast, the space plane will take advantage of the atmosphere. Its body will be supported by the lift of the main wing and it will be thrust forward by an air-breathing engine that uses the oxygen in the air, etc.

In the United States there was a time when such a space plane was the target of development. However, it sought to achieve both manned flight and a winged collection plane in its early stages. As a result, it developed the space shuttle, which is based on rocket technology. This was an intermediate step toward realizing an ideal goal. The mid-air explosion of the Challenger in January 1986 and the "New Orient Express" concept announced by President Reagan a month after that made the eyes of the space transport scientific technicians of the world turn again to the space plane. The Challenger accident led people to conclude that a space transportation system based on rockets is inadequate and that it cannot ensure safety.

A great new technical idea is required for the space plane, which aims at reaching the ultrahigh altitude destination called space by high-speed flight using basic aircraft technology. The current limits of conventional aircraft are Mach 3 and an altitude of 20 km. The space plane must have performance characteristics about 10 times those of such aircraft. Further, the idea of throwing away the used sections of a multistage craft, which is commonly done with rockets, cannot be directly applied to the space plane. Given the degree of maturation of technology, there is some consideration of a two-stage system or so that will reduce weight, but the goal is to create a fully reusable manned plane.

An air breathing engine that inhales air at high speeds to generate its thrust holds the key to the realization of the space plane. Thanks to this engine, the amount of the oxidizer (liquid oxygen is a typical one) which is the heaviest thing a rocket loads, can be reduced by a large margin. This will make it possible for the space plane to reach space using its main wing--the structure for takeoff and landing--and an air-breathing engine.

#### (I) Worldwide Trends

A number of countries have the space plane-related projects with advanced technical research underway. These include the United States, Britain,

Table 1. R&D Plans of Representative Space Planes HST in Europe

Country	Britain	France	West Germany	
Name of project	HOTOL (Horizontal Take-off and Landing)	HERMES	Saenger Space Transport System	
Organization	BAe (P&R : engine)	Aerospatiale	DFVLR MBB	
Operational in Europe	Type	Reusable vertical launching part small space shuttle type. To be launched as payload of Ariane V rocket	●2-stage space plane (TSTO) ●HST (booster)	
	Scale/performance	●76 x 20 m ●200 t ●Payload 7 t ●2-1/2 hrs between London and Sydney	●18 m x 10 m x 5 m ●20 t ●Payload = 2 t ●2 pilots ..... Ariane V rocket Thrust: 1,600 t	
	Engine	●ABE: Air liquefying engine	No engine	●ABE: Turbo ram jet ●Orbiter engine is rocket
	Development plan	Aims at practical use in 1998	●1987: Started development ●1996: Aims at launching	●Start development after 4-6 years of technical research

France, West Germany, and the USSR. Table 1 shows an outline of the projects of these countries, except for the USSR. All the space planes except the Hermes of France are of the horizontal takeoff and landing type. The aerodynamic shape of these planes may be a little different: (5) in Figure 2 is the shape of the U.S. and British planes, (4) is the West German Saenger, while (1) is the French Hermes. The United States is the most enthusiastic, and it is said that the test manufacture of an air-breathing engine for the NASP for ground testing has already started. The HOTOL of Britain and the West German Saenger have been proposed to the European Space Agency (ESA) for adoption as a space development target for a next generation transport system, and their development is being advanced by the respective countries.

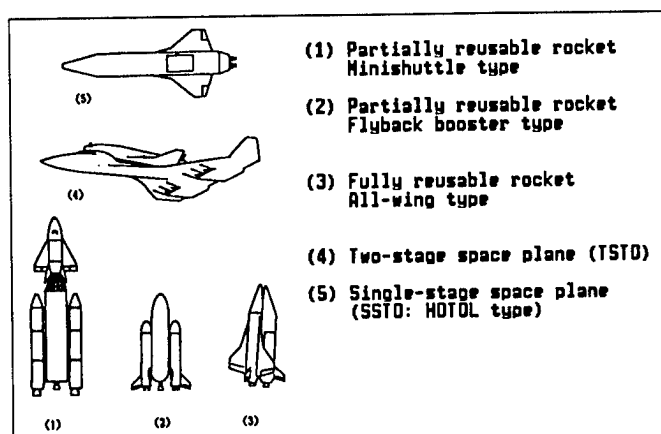

Figure 2. Shapes of Various Space Planes

All of these projects are also taking into consideration the development of a hypersonic transport (HST) at the same time.

## (II) Technical Problems of Space Plane

### (1) System

The system form of the space plane will be dictated by the technology that can be utilized. Particularly important is the degree to which the air-breathing engine can be realized. It will probably become necessary to make the plane a multistage rather than a single-stage vehicle. It is difficult to narrow down the present research work to define a Japanese concept, but the system study is to be conducted in the sense of exploring various possibilities and to carry out a technical evaluation of the respective cases. Figure 3 shows representative flight paths of the space planes that are clearly different from that of the space shuttle, which is launched by a rocket. The presence of air offers only a small resistance to the rocket at the time of launching. The rocket cuts through the air vertically without increasing its speed and accelerates in outer space. By contrast, the space plane utilizes the air to the limits of the performance of its engine and body. The flight envelope of presently used aircraft and the maximum recorded point of America's hypersonic experimental X-15 rocket are shown in the figure. Japan's space plane will try to fly at least to point A, and will fly to point B using the air-breathing engine if higher technology can be realized. But it can be seen that the space plane faces several problems, especially in the challenge of speed, given the present level of technology. The figure also shows the most current version of the flight path of America's NASP, which is designed for flight under the very severe conditions of air resistance and aerodynamic heating at high speeds in higher air density.

Figure 4 shows the body concept of a single-stage space plane and the related technical problems. There are various elements and basic technical problems, and it will probably be necessary to conduct research across a

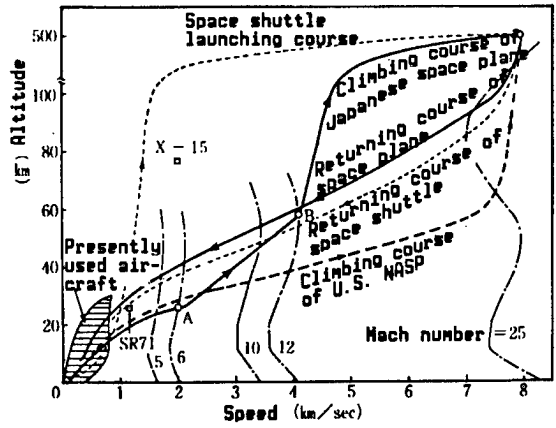

Figure 3. Typical Space Plane Flight Paths

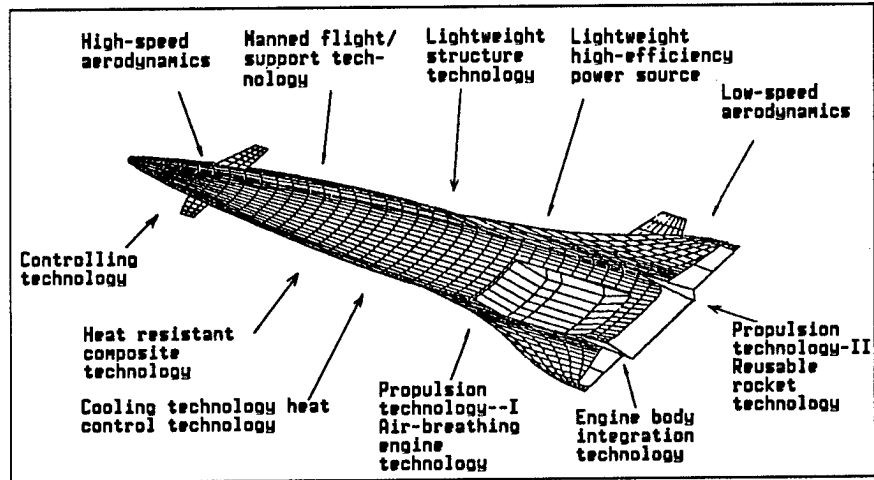

Figure 4. Single-Stage Space Plane and Its Principal Technical Requirements (National Aerospace Laboratory)

wide range of fields to solve these problems. An outline of the principal technology and the direction of technical development will be presented below.

**(2) Body System Technology**

High-speed aerodynamic technology, the heat resistance of the body, lightweight structure technology, controlling technology, etc., are the principal technical subjects. Aerodynamic technology requires a low-resistance body to make it possible to fly at speeds beyond Mach 6, which no man has ever explored. Figure 5 shows the relation between the Mach number and the body shape, and it is desirable to adopt the wave rider concept (shock wave utilizing hypersonic shape). Combination with the engine is also important, and thrust is generated at the broad undersurface of the body to overcome the high air resistance.

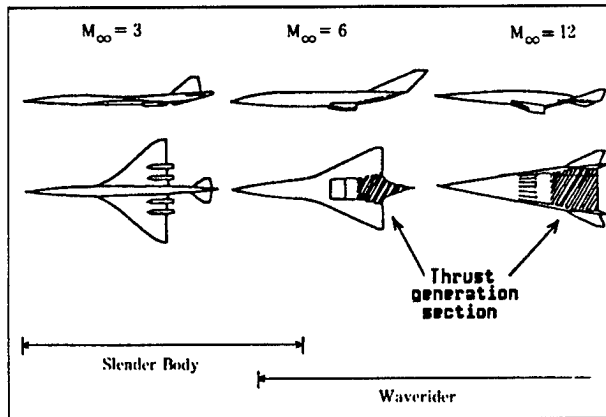

Figure 5. Flying Speed and Aerodynamic Configuration of Body

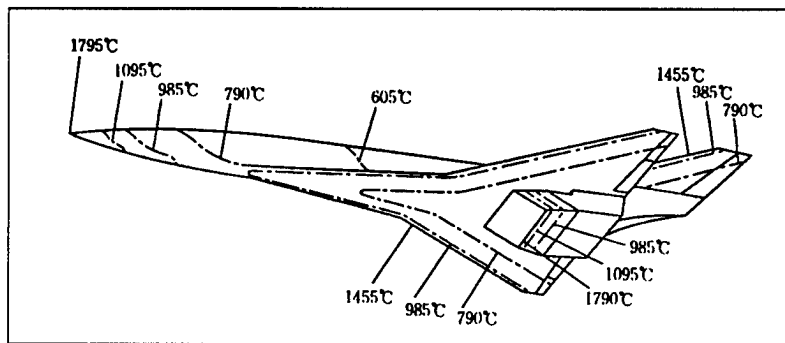

Figure 6. Body Heat Resistance Requirements for Space Plane (Mach 6.5, Altitude 20 km)

Figure 6 shows the aerodynamic heat experienced by the body during high-speed flight. The air will have thermal energy corresponding to the plane's speed and will heat the body by its impact with it. This is aerodynamic heating, which cannot be avoided in high-speed flight. The figure shows the aerodynamic heating to the various parts of the body. When flying at a speed of Mach 6, the temperature at the nose and the engine intake reaches 1,800°C. The body must cope with this by using heat-resistant materials and by cooling. Making a lightweight structure by the positive utilization of composite materials, etc. is also one of the main subjects.

### (3) Propulsion Technology

The propulsion engine for the space plane consists of an air-breathing engine and a rocket engine. The main technical subject is the air-breathing engine, where there is no experience. Air breathing means literally to take in air, and this name is used in contrast to rockets that load an oxidizer. Figure 7 shows the main concept applied in different ways. These include the turbo system engine for use from takeoff to about Mach 6 and a ram jet and an air liquefying cycle (LACE) engine for use at high speeds. Attaining high speeds is the primary goal for each of these engines. To do this, it will be necessary to establish an intake



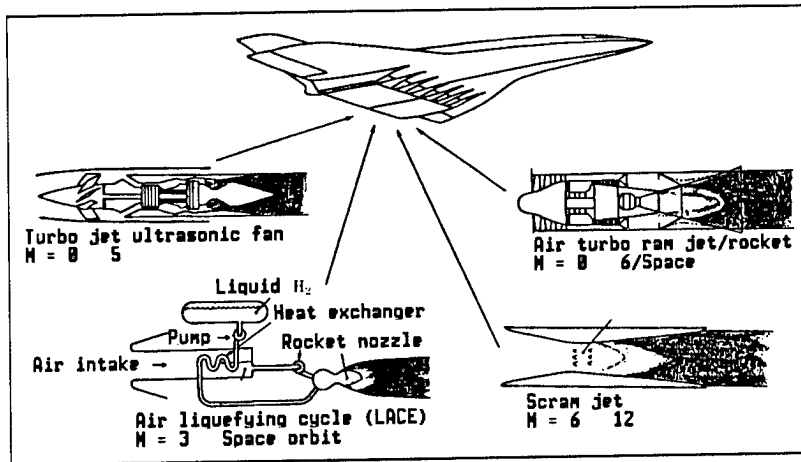

Figure 7. Concept of Engine for Space Plane

technology, high-speed combustion technology, heat-resistant materials, and cooling technology for temperatures of 2,500°C, and variable control technology corresponding to the flying speed. Figure 8 shows the specific impulse against the Mach number to describe the performance of these engines. Specific pulse may be viewed as efficiency. The specific impulse of the air-breathing engine is much higher than that of the liquid oxygen-liquid hydrogen rocket engine, and this value will change in proportion to the Mach number. There is no one engine that has the full range of required performance characteristics even in the range of Mach numbers shown here, and it is believed it will have to be a composite engine. The engine technology bases Japan possesses are for the jet engine and the rocket engine, and the fusion of the two bases and a new system technology will be required for the new engine.

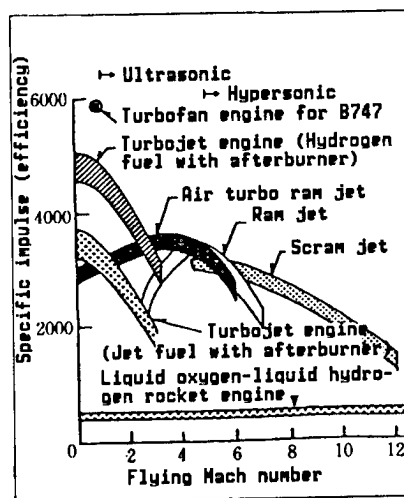

Figure 8. Performance of Various Air-Breathing Engines

#### **(4) Others, Ground Equipment, Etc.**

In addition, such technologies as manned flight technology and life support technology are required. Except for the space plane itself, ground facilities including takeoff and landing places and the equipment for testing R&D are inevitable. Even if limited to the main testing required for R&D, the following pieces of equipment are required: large ultrasonic/hypersonic wind tunnels, a thermal wind tunnel to test the heat-resistant technology of the body, heat-resistant structure testing equipment, a space simulator, high-altitude performance testing equipment for engines, an ultrasonic engine wind tunnel, engine elements testing equipment, etc.

This equipment is required not only for the space plane but also for R&D on aircraft and engines, and it is certain that these will become the motive power for the development of Japanese aerospace technology and industry. The preparation of this equipment without delay is essential to pave the way for the space plane R&D program.

#### **4. Conclusion**

Many aspects of the technology and other elements of the Japanese space plane have been presented. Basic essential research, the study of concepts, etc., are currently being conducted primarily by the National Aerospace Laboratory, the National Space Science Laboratory, and NASDA. The "Space Plane Coordinating Committee" was created by these three organizations in July of last year to discuss the project concretely under the guidance of the Science and Technology Agency, and it has begun its activities. This committee is carrying out various activities including publicity, to say nothing of the exchange of mutual research work, aimed at the full-scale start of R&D on the Japanese space plane.

It is anticipated not only that the space plane will become one of the pillars of independent Japanese space development in the 21st century, but also that it will have a great impact on the development of aerospace technology and related industrial fields that are expected to play an important role in advancing science, technology, and industry in the 21st century. This would give Japan an independent role and position in the aerospace industry, which will increasingly become internationalized, and will enable Japan to play a useful role in international cooperation and harmony as a country advanced in science and technology.

20155/9365

National Aerospace Laboratory News Update

43062070 Tokyo KOGIKEN NYUSU in Japanese Feb 88 pp 1-2

[Text] Measuring Tectonic Plate Movement by Satellite Laser Range Finding

According to plate tectonics, the earth's surface is covered with about 10 approximately 100-km-thick hard rock slabs called plates which move horizontally without deformation like rigid bodies. Their movement against each other along the edges where they meet is thought to be the cause of major earthquakes. Measuring the movement of the earth's crust and plates is a topic of greatest importance in NASA's tectonic dynamics project because it corroborates the hypotheses of plate tectonics and could help predict earthquakes.

Following the international project MERIT (KOGIKEN NYUSU No 315), the National Aerospace Laboratory as part of its research for space utilization technology has been participating in NASA'S tectonic dynamics project doing analysis of satellite laser range data. It recently completed analysis of about 3.3 years (September 1983 through December 1986) of laser range data with respect to the American geodesic satellite LAGEOS. This is the first successful attempt in Japan to measure the movement of plates by satellite laser range finding technology. In particular, this was the first success in using satellite laser technology to measure the relative movement between the Eurasia plate and the Pacific and Indo-Australia plates, taking as the base point the Maritime Safety Agency's Shimosato station in Nachikatsuura-cho, Wakayama Prefecture, which sits atop the Eurasia plate.

Raw observation data from laser stations all over the world was provided to the LAGEOS satellite by NASA. Because of the huge volume of data, averaging 500,000 items per month, the National Aerospace Laboratory compressed 3 minutes' worth of data into a single datum called a normal point before analyzing it.

Ultimately it derived 139,837 normal points from 13,345 passes over 41 stations during a 3.3-year period. Of the 41 stations, data for detection of plate movement was taken from only the 15 stations shown in Fig 1 which met the condition of continuous acquisition of high-precision data for a year or longer.



図1 プレート運動観測のためのラジオレーザーネットワークとプレート境界、および太平洋プレート上の3局と下里間の基線長変化率(単位: cm/year)

Fig 1. LAGEOS laser network for observation of plate movement, the plate boundaries, and the rate of change in length (in cm/year) of the baselines between Shimosato and three stations on the Pacific plate

At the National Aerospace Laboratory, 30 days of LAGEOS orbits are taken as the data processing unit (arc). Normal equations for the estimation parameters are constructed from the normal point data for each arc. Then an annual average unique solution is obtained by simultaneously processing the normal equations for 12 arcs, a year's worth. In doing so the orbital elements, LAGEOS drag coefficient, solar radiation pressure coefficient, and earth rotation parameters (polar motion, universal time) are solved as the estimation parameters for each arc and the position coordinates for all arcs as a whole. The baseline length (distance between stations) is calculated from the position coordinates for each pair of stations. But in calculating the baseline length, changes in the vertical direction are not considered, since we are interested in the displacement in the horizontal surface, the same as with the hypotheses of plate tectonics. The annual average position coordinates and baseline lengths are thus successively determined, and from the annual changes in the baseline lengths the rate of change of the baseline lengths and the average speed of movement of each plate are observed.

Minster and Jordan (1978) estimated (it is called the AM 1-2 model) the average plate movement for about 3 million years from geological data including the orientation of transform faults, the direction of hypocenter slip vectors, and the striped patterns of geomagnetism in the ocean floor. The rate of change in baseline lengths as determined by laser agrees surprisingly well with the speed of the plate movement estimated from this geological model. As an example, Fig 1 shows the rate of change in the baseline length between the Shimosato station and three stations in the Pacific plate (Monument Peak, Hawaii, and Huahine). Negative values indicate

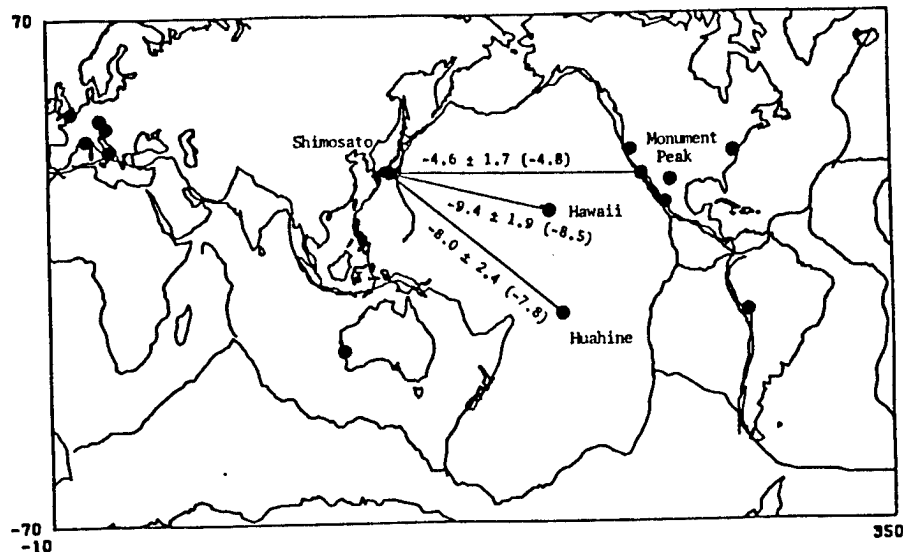
a shortening of the distance. In Fig 1 and in the following, figures in parentheses denote values predicted by the AM 1-2 model. The main results concerning plate movement which were obtained from this analysis of the data are as follows:

- 1) The Japanese archipelago (Shimosato station) and Hawaii are getting closer to each other at about 9.4 cm (8.5 cm) a year.
- 2) The Japanese archipelago (Shimosato station) and Australia are getting closer to each other at about 6.5 cm (6.5 cm) a year.
- 3) Hawaii and the South American continent are getting farther from each other at 4.4 cm (4.6 cm) a year.
- 4) Hawaii and Australia are getting closer to each other at 7.7 cm (6.7 cm) a year.
- 5) Australia and the North American continent are getting closer to each other at 1.8 cm (1.5 cm) a year.
- 6) Hawaii and the North American continent are getting farther from each other at 0.7 cm (1.3 cm) a year.
- 7) Australia and the South American continent are getting farther from each other at 2.7 cm (2.4 cm) a year.
- 8) The North American continent and Western Europe are as a whole getting farther from each other at 2.4 cm (1.6 cm) a year.
- 9) The North American continent and the South American continent are getting closer to each other at 1.2 cm (0.8 cm) a year.
- 10) Western Europe and the Japanese archipelago (Shimosato station) are getting closer to each other at 1.1 cm (0.0 cm) a year.

These results corroborate the hypotheses of plate tectonics and provide interesting information about how the plates are actually moving now. An accumulation of high-precision laser range finding data should make it possible in the near future to measure plate movement with greater reliability and with a shorter time for resolution.

(Masaaki Murata, Instrumentation Division)

13278/06662

Operational Performance of Engine on Fan Jet STOL Asuka

43062070b Tokyo KOGIKEN NYUSU in Japanese Feb 88 pp 4-6

[Text] Flight testing of the low-noise STOL experimental aircraft Asuka has proceeded almost without a hitch since its first flight in October 1985, and it succeeded in its actual test STOL takeoff in October 1987 (KOGIKEN NYUSU No 344). In this article we discuss how the Asuka's FJR710/600S engine has performed.

Six engines (numbered E01 through E06), including replacement engines, were made for installation in the experimental craft. After primary and secondary engine airborne testing carried out in 1984, in March 1985 the first installation of engines in the craft was completed. The operation of the engines thereafter is shown in Fig 1.



図1 FJR710/600Sエンジン運用経過

Fig 1: Schedule of operation of the FJR710/600s engines [Key on next page]

1. Engine number
2. Total hours in operation (hours in operation while mounted in craft)
3. Endurance running testing and technology testing
4. Endurance running testing and technology testing
5. Technology testing
6. Initial engine installation
7. Maiden flight of the Asuka
8. Taking delivery of the Asuka
9. Period of operation while mounted in the Asuka (except EX01)
10. Figures in parentheses show length of time in operation while mounted in the Asuka.

Based on the results of the endurance running testing, after 1540 hours in operation each engine was taken down and overhauled (completely disassembled and inspected), and flight testing was facilitated by using the six engines in rotation. Fig 2 shows the work of replacing one engine with another.

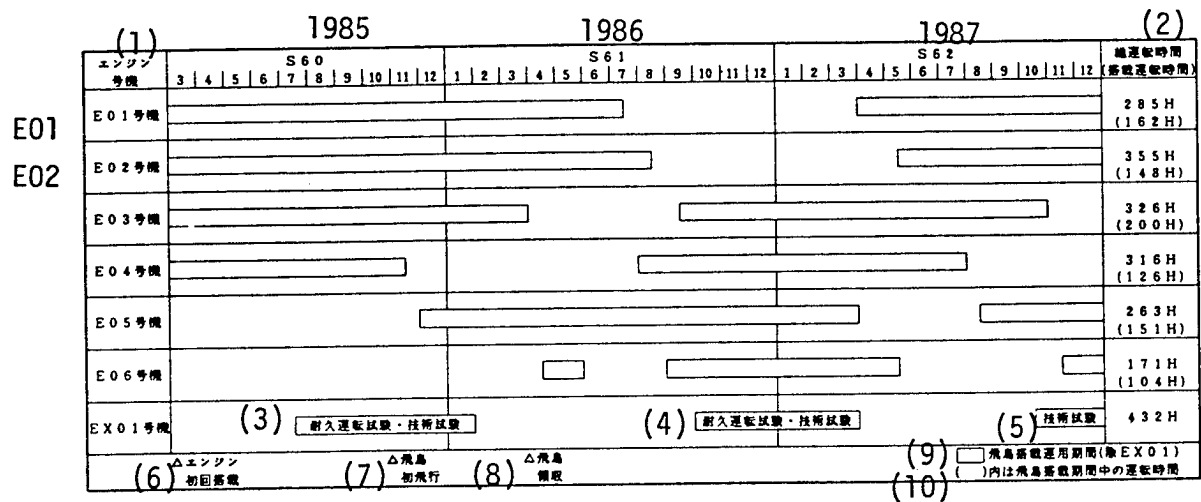

図2 エンジン換装作業状況

Fig 2: The work of engine replacement

Fig 3 shows examples of the operation of engines in flight testing, giving the fan speed of four engines from start-up to shut-down. Because these examples are of simulated takeoff flight tests in the air near the Gifu airfield, although the duration of the flight is short, the engine is subjected to severe operation, with takeoff propulsion used five times during each flight.

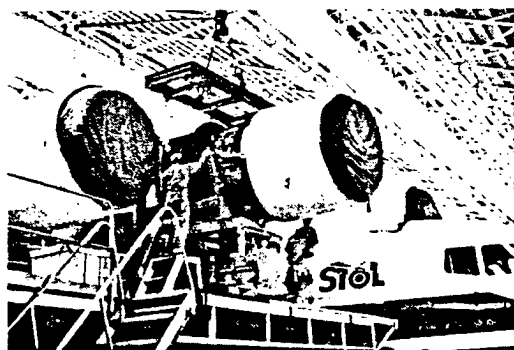

図3 飛行試験におけるエンジン運用例

Fig 3: Examples of engine operation in flight tests

In addition, as testing in support of the flight experiments, technical tests were carried out in order to elucidate newly occurring technical matters. This was done by on-the-ground endurance running tests and mounted operation with an operational cycle which is a compressed simulation of the operation of the engines in the experimental craft, using for the on-the-ground tests engine EX01 in the same mode as the engines mounted in the craft. The results were applied to the mounted engines in order to improve their performance, functions, durability, and operational limits.

The running times for each of the engines used in the experimental craft in the STOL project are shown in Fig 1; the cumulative running time for engines E01 through E06 which were mounted in the craft came to 1,700 hours. Adding to this the running time of engine EX01 and of the model /600 engines in large-project research and development, the total running time for the FJR710/600 and 600S engines is more than 4,500 hours. Generally incremental improvements are made to an aircraft engine even after it goes into actual service, and the engine gradually comes to full maturity. With this engine too, the deficiencies encountered when it first went into operation have been overcome, and now it operates relatively stably. With the cooperation of all those involved, we would like to maintain the smooth operation of the engine and proceed with flight testing.

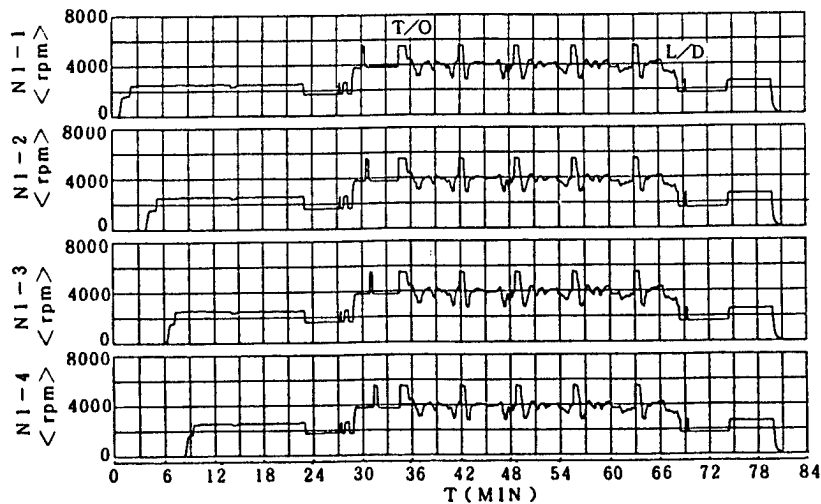
(STOL Project Promotion Headquarters, Engine Technology Development Office)

13278/06662



National Aerospace Laboratory's 10 Cm x 10 Cm Magnetic Support Balance for Holding Models in Wind Tunnels

43062070c Tokyo KOGIKEN NYUSU in Japanese Feb 88 pp 7, 8

[Text] There are many still unsolved problems in wind tunnel testing for duplicating on the ground the flow around a flying body such as an aircraft or rocket. Discrepancies between Reynold's numbers and interference caused by the walls of the wind tunnel or by the apparatus used to support the model in the wind tunnel are problems that have long been pointed out and on which research continues. Magnetic support of the model is thought to solve completely the problem of interference caused by the support device. A magnetic support balance is a device which uses magnetic force to maintain the test model within the airstream in a wind tunnel and measures the aerodynamic force on it by measuring the amount of electric current needed to generate the magnetic force. Because of the way it operates, a magnetic support device causes no external disturbance to the airstream around the model. Much research was done in magnetic support balances in the 1950s and 1960s; but because of the difficulty of their large size, little work has been done since then, and until today only about 15 magnetic support balances have ever been built. Only four are now in use in the world. But in recent years the possibility of magnetic support balances using superconductivity technology has been noted, and once again NASA and others are doing research in magnetic support balances. Moreover, recent progress in electronics technology has made it easier to make high-precision position and attitude sensors and to provide an environment in which high-speed digital control can easily be incorporated. The research into magnetic support balances embodying this new technology is very significant, regardless of the size of the devices.

The National Aerospace Laboratory began research in magnetic support balances in fiscal 1987 and completed basic components. In October 1987 it completed parts for a magnetic support balance capable of control with three degrees of freedom. The test section has a 10 cm x 10 cm cross section and is 30 cm long. As seen in Fig 1, there are 10 coils in all for controlling the magnetic field within the test section, and the device is designed so that each coil is appropriately controlled. An Alnico permanent magnet is embedded in the model along its axis and is attracted and repelled by the 10 coils

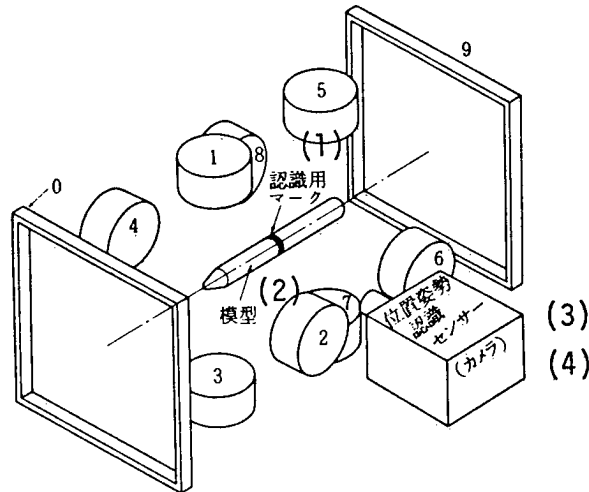

(5) 0, 9 : 抗力用コイル (空芯コイル)  
 (6) 1, 3, 5, 7 : 揚力, ピッチングモーメント用コイル  
 (7) 2, 4, 6, 8 : 横力, ヨーイングモーメント用コイル  
 図1 航技研 10cm x 10cm 磁力支持天秤

Fig 1: National Aerospace Laboratory's 10 cm x 10 cm magnetic support balance

1. Mark for recognition
2. Model
3. Sensors for detecting position and attitude
4. (Camera
5. 0, 9: coils for drag (air-core coils)
6. 1, 3, 5, 7: coils for dynamic lift and pitching moment
7. 2, 4, 6, 8: coils for lateral force and yawing moment

outside the test section so as to maintain the model in the desired position and attitude. In the control system, shown in Fig 1, every 8 msec the position and attitude of the model is measured by sensors positioned outside the test section. These sensors were developed independently by the National Aerospace Laboratory. Any deviations from the prescribed values are fed into a 16-bit microcomputer, which controls the amount of current flowing in the external coils so as to cancel out the deviations.



図2 航技研磁力支持天秤制御部概念図

Fig 2: Conceptual diagram of the control section of the National Aerospace Laboratory's magnetic support balance

- 1., 2. Display of position and attitude
3. Recognition of position and attitude
4. Evaluation of size of deviation, calculation of control quality
5. Power amplifier
6. 16-bit personal computer
7. Coil
8. The model
9. Sensors for detecting position and attitude (camera)

The parameters presently controlled by this magnetic support balance are, in the case of an aircraft model, its position in the up-down and front-back directions and its attitude in the vertical direction. Its position in the left-right direction and its orientation are set so that the model is inherently stable due to the magnetic field generated by the magnetic support balance. Rotation of the model about its fuselage axis is not controlled. Fig 3 [omitted] shows an example of actual magnetic support. The model has an angle of elevation of -3 degrees, and the center of the mark which is pasted onto the model so that its position and attitude can be measured is kept in the center of the test section. Fig 4 shows the changes in position and attitude observed when the position of the model was varied upward stepwise by 2 mm.

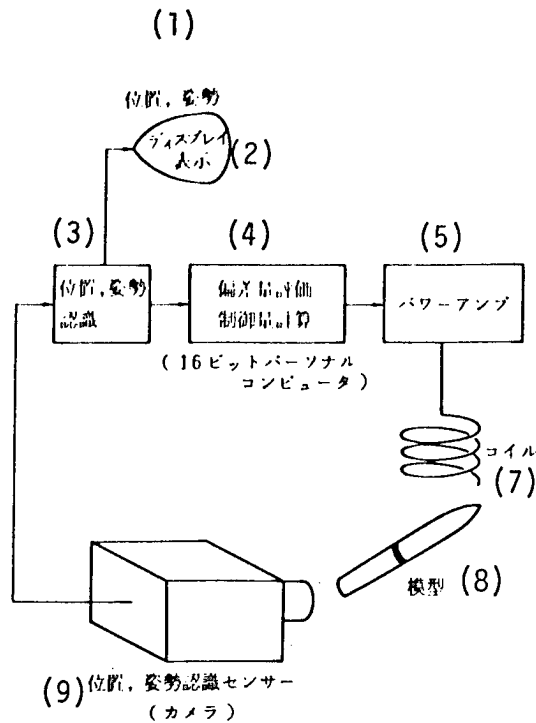
MSBS TEST		RUNING DATA			
	X	Y	Z	Theta	Psi
Initial :	0.427	-19.353	-1.177	-0.241	2.305
Set point :	0.427	-19.408	0.816	-0.226	2.243
K P :	20000.	0.	4000.	2000.	0.
T I :	50.	0.	50.	10.	0.
T D :	100.	0.	100.	50.	0.
Graphic 0 :	0.000		-1.000	0.000	



図4 磁力支持されている模型を2 mmだけ階段状に上昇させる命令を与えた時の模型の応答

Fig 4: Response of a magnetically supported model when given an order to rise stepwise by 2 mm

1. Coil current for rearward dynamic lift
2. Coil current for drag
3. Coil current for forward dynamic lift

In the future we plan to make the control speed even faster and make improvements to the digital control software. We also are rushing to complete the remaining parts of this magnetic support balance and plan to collect basic data needed for building a larger magnetic support balance.

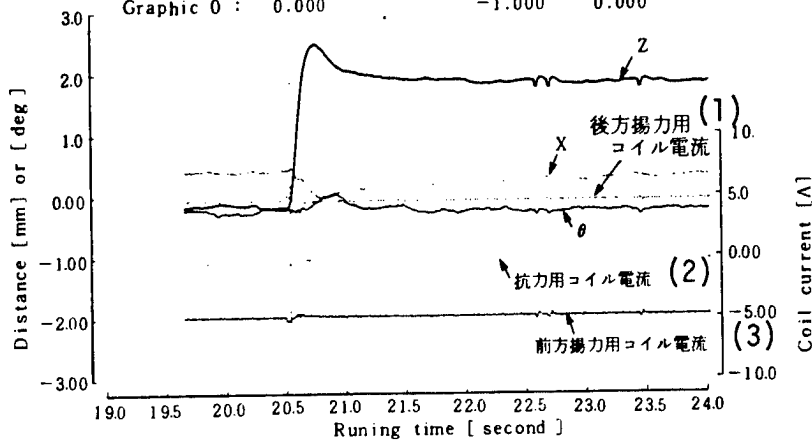
(Hideo Sawada, Aerodynamics Department No 2)

13278/06662

## Aerodynamic Testing of ACT All-plane Elastic Model

43062070d Tokyo KOGIKEN NYUSU in Japanese Feb 88 pp 9-10

[Text] As reported earlier, we are making preparations for gust load attenuation (GLA) tests using a large all-plane elastic model. Following the rigidity tests and the vibration tests done earlier, we now report on the aerodynamic measurement tests carried out on the ACT all-plane elastic model.

The experiments were carried out at our large low-speed wind tunnel 6.5 M x 5.5 M. Since the deformation of the elastic main wing is excessive when the wind speed is 25 m/s or more, 20 m/s and 25 m/s were chosen as the wind speeds for the experiments. In the experiments we performed a basic mode (aileron angle  $\delta_a = 0^\circ$ , elevator angle  $\delta_e = 0^\circ$ , rudder angle  $\delta_r = 0^\circ$ , angle of movable horizontal stabilizer  $\delta_H = -3^\circ, 0^\circ, 1.5^\circ$ ) six-minute force test, aileron effectiveness test (same-phase steering, reverse-phase steering, one-side steering), elevator effectiveness test, rudder effectiveness test, and aileron steering response test. These tests revealed the aerodynamic characteristics needed for the GLA experiments simulated in connection with the rigid-body movement of the fuselage.

Fig 1 [omitted] shows the state of wind tests with a wind speed of 20 m/s,  $\delta_2 = 0^\circ$ ,  $\delta_e = 0^\circ$ ,  $\delta_r = 0^\circ$ ,  $\delta_H = 1.5^\circ$  in the cases of an angle of elevation of  $+5^\circ$  and  $-7.5^\circ$ . Since the main wing of the model is an elastic body, the difference in angle of elevation produces a large deformation. Fig 2 shows the lift coefficient  $C_L$ , drag coefficient  $C_D$ , and vertical pitch moment coefficient  $C_M$  for angle of elevation  $\alpha$  when the wind speed is 20 m/s and 25 m/s. The difference in wind speed gives rise to differences in lift and drag which are thought to cause the deformation of the main wing. The lift at angle of elevation  $0^\circ$  is about 15 kg with a wind speed of 20 m/s and about 20 kg with a wind speed of 25 m/s. Meanwhile, in the GLA experiment performed in near-free-flight conditions with a model weight of 36 kg, the insufficient lift was made up for by the movement support system. The drag on the model is about 3 kg at most, and it is thought that the deformation of the model support rod is sufficiently small not to have much effect on the rubbing motion of the model. Good vertical stability is shown, with the curve for  $C_M$  sloping to the lower right at about  $C_M = 0$  when  $\delta_H = 1.5^\circ$  and the angle of elevation is  $0^\circ$ . Although there is some lateral force, it is small enough to be adjusted for by the steering surface, and it is confirmed that the balance of this model is sufficient for the GLA experiments. We now plan to take

these aerodynamic characteristics into account in examining the steering surface control, and to go ahead with the GLA experiments.



図2 基本形態空力特性 (風速 20 m/s と 25 m/s の比較)

Fig 2: Basic-mode aerodynamic characteristics

(ACT research group)

13278/06662

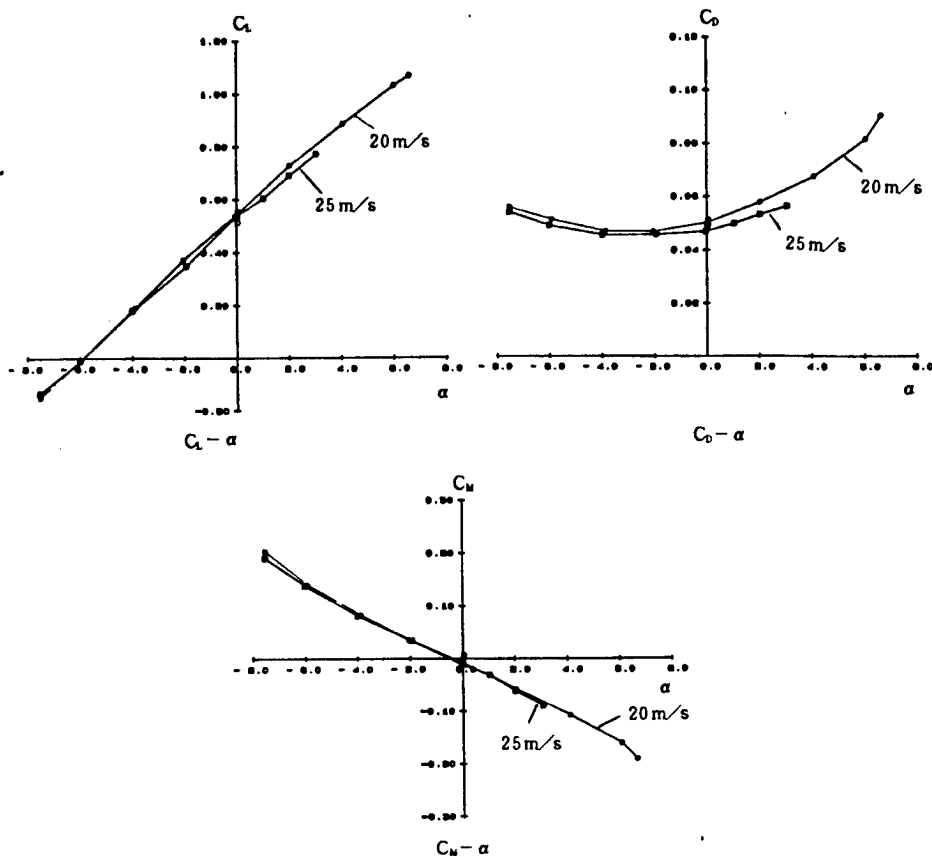
Japan To Build Manned Space Platform

43070005a Tokyo KYODO in English 0325 GMT 21 May 88

[Text] Tokyo, 21 May (KYODO)--Japan plans to construct a carousel-shaped manned space platform, 200 meters in diameter, at the beginning of the 21st century to serve as a frontier base for space environment utilization, the National Aerospace Laboratory (NAL) said Saturday.

NAL officials also said artificial gravity will be provided in order to maintain crew's health and their task execution capability, the first such attempt in the world.

The platform will mechanically separate the section for habitation, where pseudogravity is generated by rotating the system, and the section for space environment utilization, where microgravity is required.

In this way, weakening of the crew's cardiac muscles and bones resulting from long periods in zero gravity surroundings will be prevented and allow space operations to be carried out smoothly.

The microgravity section will be weakly connected to the rotating section through the electro-magnetic suspension mechanism, and the transit cabin will be used for crews to commute between the two sections, NAL's space technology research group reported.

An independent power supply and life support system will be provided to each section to avoid unnecessary interaction, according to the report.

A total of 16 crew can operate on board for a period of at least 3 months.

Expected to be completed in 2015, this 240-ton project will cost as much as 1.06 trillion yen.

Japan's space activities, considered to be lagging far behind those of the United States and the Soviet Union, will take a giant step forward upon its completion by providing Japan with a base to explore deep space as well as a site for life science research conducted in a microgravity environment, a NAL official said.

Japan is currently dependent on the United States in this area, but hopes through participating in the international space station program, a joint venture by Japan, the European Community, Canada and the United States in the 1990s, to accumulate necessary knowledge for the project.

NAL will make a report on this project at an international symposium on space technology and science to be held in Sapporo next Monday.

/9604



Space Station Envisages Artificial Gravity

43070005b Tokyo KYODO in English 0425 GMT 24 May 88

[Report by Tim Johnson]

[Text] Sapporo, 24 May (KYODO)--Officials of Japan's National Aerospace Laboratory (NAL) proposed here Tuesday a Japanese version of the U.S.-initiated international space station that would be launched in the year 2005.

Speaking at the 16th international symposium on space technology and science, NAL senior researcher Keiji Nitta proposed the development of an axis-controlled "manned space platform" with separate weightless and gravitational environments.

NAL researcher Mitsuo Oguchi told KYODO News Service that the first phase of the solar-powered Japanese space station could be completed in the year 2005 if research funds were made available to the financially strapped laboratory.

Oguchi also said the first-phase platform would be manned by two or three astronauts. The three-phase project would be completed in 2020-30.

NAL is the second-largest national laboratory in Japan and the largest in the Science and Technology Agency, Oguchi said. He said the Tokyo-based laboratory is responsible for the development of the "Asuka" short-takeoff aircraft.

Nitta told the international gathering of scientists and engineers at the symposium that his group's idea is a departure from the system used in the international space station in that the crew of the latter will be subjected to a zero-gravity environment during their 90-day mission.

The Japanese version, however, would have an artificial-gravity generating system, Nitta said. He said artificial gravity is required to maintain the health and comfort of crew members during prolonged stays in space.

Nitta and his research team have proposed that the module housing the crew's living quarters be rotated separately from the other components on the axis to create the required "pseudo-gravity."

A weightless environment, however, is required for the processing of new materials and the production of pharmaceuticals, he said.

The non-rotating "microgravity module" would therefore have to be mechanically separated from the "habitat module" to minimize acceleration disturbances, Nitta said.

The group proposed a configuration in which a special transit cabin would be used for commuting between the two modules, employing an electromagnetic suspension mechanism. The scientists also proposed that each module have an independent power supply system and life support system.

The platform could serve as a frontier base for space exploration, such as a manned flight to Mars, Nitta said. He also said that it could be utilized by astronauts returning from long missions in space.

Nitta said the idea for the Japanese manned space platform is in line with a comprehensive space infrastructure development plan produced by the Space Activities Commission (SAC), an organ in the prime minister's office that determines the country's space policy.

The commission advised that Japan build its own fleet of space shuttles and engage in manned space flight, signalling Japan's intention to participate vigorously in future space exploration.

/9604

Space Agency Cites Progress on Japanese Shuttle

43070005c Tokyo KYODO in English 1446 GMT 26 May 88

[Report by Tim Johnson]

[Text] Sapporo, 26 May (KYODO)--National Space Development Agency of Japan (NASDA) officials here Thursday gave a progress report on the development of an unmanned reusable space plane, to be completed in the next decade.

The NASDA officials, speaking at the 16th international symposium on space technology and science, said the H-II orbiting plane (Hope), a winged reentry space vehicle, is being developed in order to facilitate Japan's growing involvement in space activities.

NASDA officials said the 7-9 ton reusable space plane will be launched in the latter half of the 1990's from the Tanegashima Space Center, south of Kyushu, by the "H-II" heavy-load launch rocket which is also under development.

During its 4-day missions, Hope will perform the recovery of space experiment products from the international space station and various platforms, the officials said.

NASDA also said that in-flight experiments utilizing microgravity will be carried out in the mini-shuttle's cargo bay.

They said the H-II launch rocket will be able to carry the cargo-laden space plane 250 kilometers into orbit in a mere 14 minutes.

Hope will then be ejected from the H-II, maneuver gradually into the space station's orbit, dock at the Japanese experiment module (JEM) and deposit its cargo, the officials said.

NASDA officials said it will then pick up new cargo, de-orbit, and reenter the earth's atmosphere for a microwave-controlled horizontal landing on a 3,000-meter runway.

Part of the mission will be controlled on the ground via a data-relay and tracking satellite. Control will be handed over to the space station when the spacecraft enters its command control zone.

Among the key technologies NASDA officials said they will need to develop for the Hope project are unmanned navigation, and control methods for rendezvous-docking, reentry, and the automatic landing of the spacecraft.

Also necessary to pull off the project is research into lightweight thermal protection for the craft during its reentry into the earth's atmosphere. The officials explained that aerodynamic heating during reentry would bring the surface temperature of Hope to as high as 1,700 Celcius.

NASDA also has in mind a more advanced manned space plane for the distant future and expects the lessons to be learned from the Hope project will contribute substantially to its development.

A NASDA official said that the reason Hope will not be manned is that such technology is still premature in Japan and a manned craft would in any case be too heavy for the H-II launch rocket to carry.

Although the idea of a Japanese shuttle craft has been around for a decade, an official said, the present concept for an unmanned winged vehicle was agreed upon by NASDA engineers last year.

This year NASDA researchers are studying the structure and equipment of the space plane and next year Hope will enter the preliminary design phase. The craft will be operational in the late 1990's, with three to four flights a year estimated by the end of that decade, officials said.

The "H-I" launch vehicle entered the operational phase in 1986. Development of the "H-II" rocket began in February 1986 and is scheduled for its maiden launch from Tanegashima Space Station in late 1991 or early 1992.

The landing site for Hope is still under consideration, Space Agency officials said. The Hokkaido Government is vying with other prefectures, including Iwate and Aichi, to attract a new space base and related aeronautics and space industries.

Hokkaido has proposed that base be built along a section of its Pacific coastline. Prefectural officials said that the area they offer would be large enough to accommodate shuttle construction industries, two launch facilities for heavy launch vehicles, and extended runways with terminal and control functions.

The northernmost prefecture will host a day-long seminar on the "Hokkaido Space Center" on Friday, the last day of the 5-day international space symposium.

/9604

**Bioreactor, Biosensor Technology Discussed**

43066555 Tokyo IMMOBILIZATION OF MICROORGANISM/ENZYME and BIOSENSOR in Japanese Mar 88 pp 1-9

[Text] I. **Bioreactors**

The process of producing useful materials by taking advantage of the versatile metabolic functions of living organisms is the primary task of biotechnology. The reactors employed are called bioreactors, where enzymes, microorganisms, and, in some cases, immobilization materials are used. In other words, bioreactors are devices for producing the desired useful materials by using enzymes and microorganisms. They are classified, as shown in Table 1, according to the modes of flow and the kinds of reactors. Figure 1 shows some representative reactors.

Table 1. Classification of bioreactors

Operation mode	Mode of flow	Reactor
Batch method	Completely mixed type	Stirred tank
	Completely mixed type CSTR* <sup>2</sup>	One-stage stirred tank Multistage stirred tank
Continuous method* <sup>1</sup>	Plug flow reactor PFR* <sup>3</sup>	Packed layer
		Fluid layer Enzyme tube Hollow-fiber packed layer Enzyme membrane

\*1 Materials that have not reacted are sometimes recycled.

\*2 Continuous stirred tank reactor

\*3 Plug flow reactor

It is advisable to choose the reactor most suitable for the biocatalyst used, or for the substrates and products. The packed layer reactor (PFR) is the most frequently used. Fluid-type reactors are also being studied.

Enzymes and microorganisms for bioreactors are used in two ways--either in a mobile state or fixed to insoluble carriers. Mobile biocatalysts are

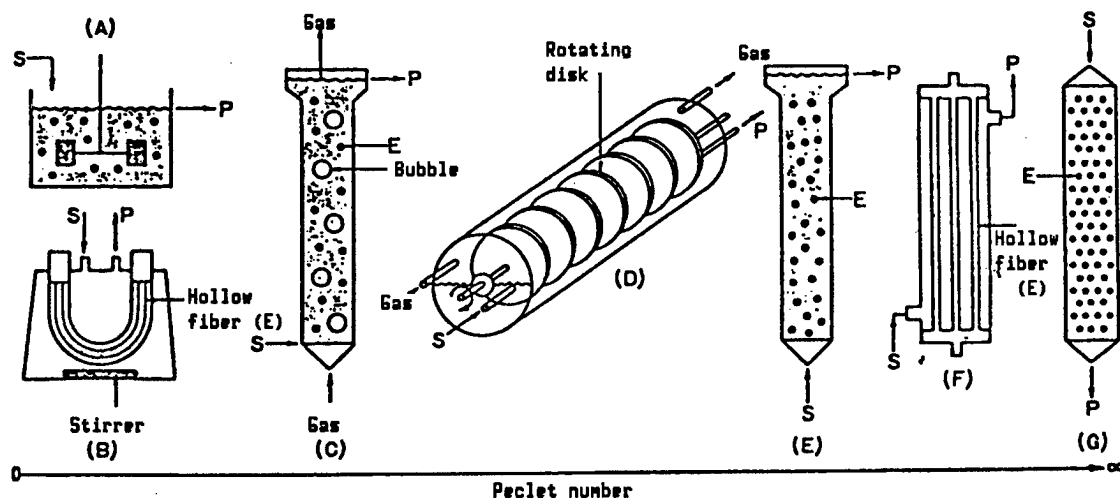

Figure 1. Various Reactors

S: Substrate  
P: Product

E: Immobilized enzymes or  
enzyme solution

- (A) CSTR
- (B) Hollow-fiber reactor
- (C) Three-phase fluid-layer reactor
- (D) Rotating disk reactor
- (E) Fluid-layer reactor
- (F) Hollow-fiber reactor
- (G) Packed layer reactor (PFR)

used for some kinds of substrates and bioreactors. For repeated use of microorganisms or enzymes, however, it is better to immobilize them by fixing them to carriers consisting of insoluble, inorganic compounds or polymers. There are a few methods for immobilizing enzymes or microorganisms:

### 1. Carrier Binding Method

Enzymes are combined physically or chemically with insoluble carriers.

### 2. Bridge Method

Making bridges of enzymes with multifunctional reagents.

### 3. Inclusion Method

Enzymes are included in high-molecular matrixes. Here, a bioreactor is manufactured with microorganisms and the immobilization of microorganisms is discussed.

The inclusion method is the most frequently used immobilization method for microorganisms. The immobilization carriers used in this case are natural high-molecular agar, calcium alginate, K-carrageenin, and synthetic

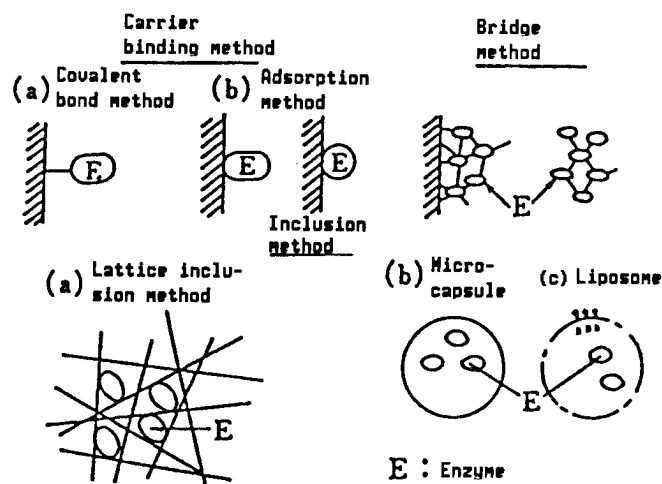

Figure 2. Enzyme Immobilization Methods

produces alcohol by using immobilized yeast has been manufactured. Calcium alginate is used for yeast immobilization.

## Experiment

### 1. Preparation of Immobilized Microorganisms

Yeast is cultured overnight on a sterilized YPD medium (yeast extract 1 percent, polypeptone 2 percent, glucose 2 percent). Then the yeast is collected in a centrifuge (10 minutes at 5,000 rpm).

A 1.5 percent (w/v) sodium alginate aqueous solution is prepared. (It is barely soluble and must be heated.) When cooled, the yeast is added to prepare a 1 percent (w/v) solution.

With a Pasteur pipet, this water solution of sodium alginate containing yeast cells is dropped into a 1 percent aqueous solution of  $\text{CaCl}_2$  to prepare bead-type immobilized yeast.

### 2. Preparation of a Bioreactor

The prepared immobilized yeast is packed into a column and a 10 percent water/glucose solution is introduced into it (Figure 3).

After a reaction period that can last from a few hours to overnight, the concentration of alcohol and glucose in the reacted solution is measured. Biosensors, which are discussed in the next section, are used for this measurement.

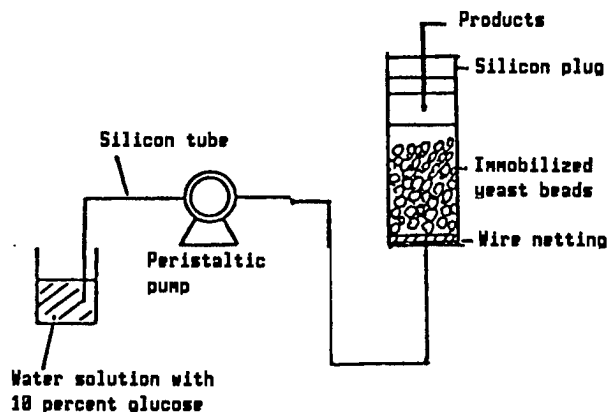

Figure 3. Bioreactor System

### 3. Materials and Equipment Used

Yeast for alcohol fermentation

Equipment: Culture facilities, centrifuge, autoclave, peristaltic pump, magnetic stirrer

Instruments: Glass column, Pasteur pipet, silicon tube, plug, wire netting, breaker, Teflon stirrer, graduated cylinder

Reagents: Yeast extract, polypeptone, glucose, sodium alginate, calcium chloride

## II. Biosensors

A biosensor measures the amount of chemical substances by making use of the various molecular distinguishing functions of living organisms. For instance, enzymes, receptors, antigens, microorganisms, animal and plant cells, and tissues have these functions and can be used as elements for a sensor.

When particular chemical substances are identified by the molecular distinguishing elements of living materials, it is necessary to have transducers present to transform the recognition into electrical signals. For this purpose, such transducers as electrodes, semiconductor elements, thermistors, and photo counters are used. A biosensor consists of biological materials and a transducer. The following describes an experiment conducted with the most frequently used enzyme sensor.

### 1. Enzyme Sensor

Enzymes, or biocatalysts, selectively promote reactions with particular substances. If this property is used, particular substances can be analyzed. In enzymic reactions, chemical substances that can be measured by transducers, such as electrodes, are consumed or produced. Thus a



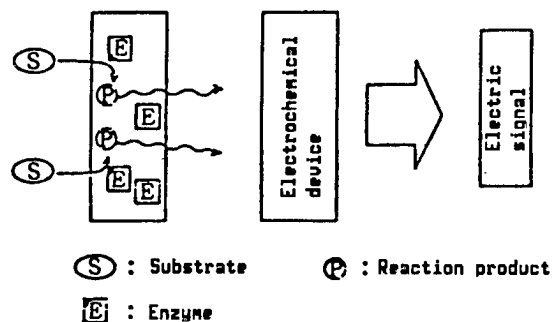

Figure 4. Principle of Enzyme Sensors

sensor can be created by combining the reaction system and an electrode (Figure 4).

An enzyme sensor consists of an enzymic element and an electrode. elements are produced by making enzymes insoluble to water (immobilized) by combining them with insoluble high-molecular membranes. This must be done because enzymes are generally water-soluble. Reactions occur when the enzyme membranes thus prepared are put into a sample solution containing chemical substances (substrates). If electrode-active substances, responding to the electrical current or reacting with it, are consumed or produced, this change is measured at the electrode as amperage or voltage. The enzyme membranes are molecular distinguishing elements and the electrode is a transducer. A practical method to produce an enzyme sensor will be introduced in this report.

An enzyme membrane is prepared by combining the enzyme and a high molecular membrane by adsorption or covalent bond, which will be closely described later. The enzyme membrane is cut to form a circle of a prescribed size which is then attached to the gas penetrating membrane of the diaphragm enzyme electrode. Next, the enzyme is covered with a permeable cellulose membrane, which is fixed with rubber rings and O-rings. Thus, an enzyme sensor can be produced. Various ion- or gas-selective electrodes are used as the electrode. At the electrode, the chemical information can be transformed into electrical information in two ways--amperometry or potentiometry. Amperometry is a method used to calculate the concentration of chemical substances from the amperes generated by the direct electrode reaction of chemical substances in the enzymic reactions. For this purpose, either an enzyme electrode or a hydrogen peroxide electrode can be used as the electrode. Meanwhile, potentiometry is a method used to calculate the concentration of ions and gases in enzymic reactions by measuring the membrane potential produced on a membrane that is selectively sensitive to the ions and gases. For this purpose, a one-valency selective electrode, selecting such ions as hydrogen ions, and gas electrodes, such as ammonium and carbon dioxide are used.

When you use an enzyme sensor that has an enzyme membrane attached on the tip of the electrode, the measurement is conducted by inserting the sensor into the sample solution. But a measurement cannot always be conducted quickly by this method. To overcome this problem, a system is constructed by inserting the enzyme sensor into a flowing-liquid cell (Figure 5). A buffer solution is continuously transmitted to the sensor, the sample solution is injected into it, and measurement is conducted. The advantage of this system is that the electrode is automatically cleansed after the measurement. In another variation, a sensor is constructed by packing immobilized enzymes into a minicolumn which is then installed apart from the electrode. In this case, the immobilized enzymes may not always be a membrane; granular immobilized enzymes are generally used. The buffer solution is continuously transfused to the system and the sample solution is poured there. The chemical substances to be measured react with the immobilized enzymes. The electroactive substances consumed or produced as a result are registered by the electrode and the concentration of the chemical substances can be measured as amperage or voltage.

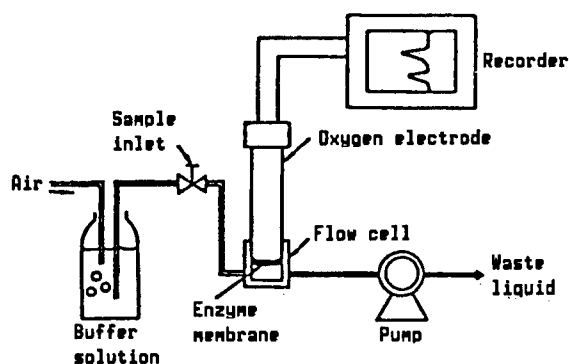

Figure 5. Liquid Flow Enzyme Sensor System

Organic compounds are measured with enzyme sensors either by the stationary method or the velocity method. In the former method, the stationary amperage or voltage is measured. From a comparison of this value and the concentration of the chemical substances to be measured, the concentration of the chemical compounds can be calculated. In the latter method, the change in the velocity of potential  $E$  or  $I$  caused by consumption or production of materials in the reaction,  $\Delta E/\Delta t$  or  $\Delta I/\Delta t$ , is measured. From the relationship between this value and the concentration of chemical compounds, the concentration of chemical compounds, which is unknown, can be calculated. When the concentration is measured in a liquid flow system, a prescribed amount of sample solution is injected to the system for a fixed period. The reaction never reaches the stationary state, which means that the amperage or voltage obtained is only some percentage of that in the stationary state. Therefore, it is considered as a kind of velocity method.

## The Experimental Method

In 1967, Updike and Hicks made the first practical enzyme sensor. They immobilized glucose oxidase on a polyacrylamine-gel membrane, which was attached to a diaphragm oxygen electrode to produce a sensor (Figure 6).

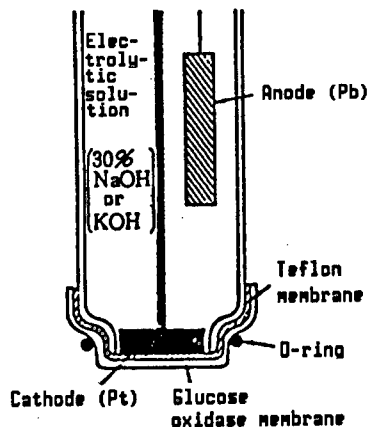
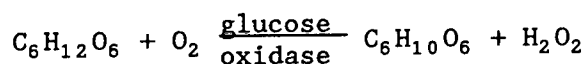

Figure 6. Glucose Sensor

If this sensor is inserted into a sample solution, the glucose in it undergoes oxidation due to the effect of the glucose oxidase. In this reaction the oxygen is consumed and gluconolacton and hydrogen peroxide are produced. The decrease in the oxygen concentration near glucose oxidase membrane can be measured by the Clark oxygen electrode fixed there. The reaction is as follows:



A part of the oxygen diffuses from the solution to the electrode where it is consumed by the enzymic reaction and the amount of oxygen reaching the electrode decreases. As a result, the electric current at the electrode decreases gradually. However, an equilibrium is formed between the oxygen diffusing from the solution to the membrane and the oxygen being consumed at the membrane, and a stable amperage is obtained. this value depends on the glucose level in the sample solution. Therefore, if the amperage is measured, the glucose level can be obtained.

Meanwhile, hydrogen peroxide is produced by the action of the glucose oxidase. Therefore, the glucose can also be calculated by measuring the amount of hydrogen peroxide at the hydrogen peroxide electrode (Pt electrode is used as cathode; its potential is set at 0.6 V against the saturated calomel electrode).

Ethanol can also be measured by the same principle and the same device. The alcohol oxidase is immobilized on a carrier membrane such as cellulose, which is attached on the diaphragm oxygen electrode to produce a sensor. Here the reaction is:

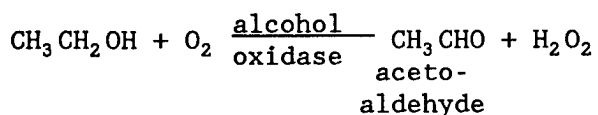

This method is based on the principle of measuring either the oxygen consumed or the hydrogen peroxide produced in the reaction.

Here, we will describe a sensor used to measure glucose and ethanol as an example.

### 1. Materials and Instruments Required

Glucose oxidase (commercially available)

Alcohol oxidase (commercially available)

Reagents: glucose, ethanol, KOH, HNO<sub>3</sub>, KH<sub>2</sub>PO<sub>4</sub>, Na<sub>2</sub>HPO<sub>4</sub>

Materials and chemical tools: Teflon membrane (two types of commercially available articles), a membrane filter (pore diameter: 0.45 μm), a cellulose dialytic membrane (commercially available), register (a few KΩ), Teflon stirrer, microsyringe, flow cell, beaker, graduated cylinder, measuring flask, etc.

Instruments: magnetic stirrer, peristaltic pump, recorder

The preparation of an oxygen electrode

(1) The gas-permeable membrane (Teflon membrane) is removed and the electrolytic solution (30 percent KOH) in the electrode is discarded.

(2) The electrode is washed with a 2N nitric acid solution.

(3) The electrolytic solution is injected into the electrode and the Teflon membrane is attached.

(4) The instruments are set as shown in Figure 7. The Teflon stirrer is put on the bottom of the beaker and the speed of rotation is converted. Then the response of the electrode is observed.

### 2. Preparation of Enzyme Membrane

First, 0.25 g of triacetyl cellulose and 5 ml of dichloromethane are put into a triangular flask with a frosted glass plug. This is stirred with a magnetic stirrer for a long period of time until the cellulose dissolves homogeneously. Then, 0.2 ml of 50 percent glutaraldehyde is added, and the solution is stirred more vigorously. After that, 1 ml of 1,8-diamino-4-amino methyloctane is added, and the solution is stirred again.

This solution is developed on a well-cleansed glass plate. If you use a glass bar with vinyl tapes coiled on both ends (the thickness of the tapes

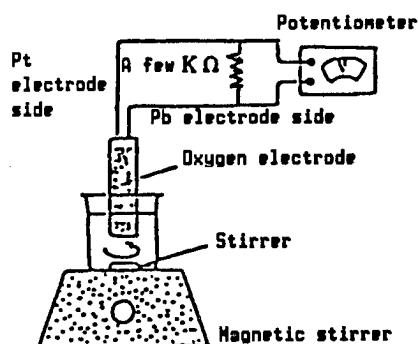

Figure 7. Oxygen Electrode System

controls the membrane thickness) in developing, a membrane with homogeneous thickness can be formed. If left for 2 or 3 days, the membrane dries and turns red. It is then cut with a knife into the correct size. If the membrane is lightly wetted, it can be readily separated from the glass.

If this solution is left for an hour in 1 percent glutaraldehyde solution (PH 8.0), glutaraldehyde is bound to the amino group in the membrane. Then the membrane is taken out of the solution and washed.

Next, 5 mg of glucose oxidase or alcohol oxidase are dissolved into 5 ml of 0.1 M phosphate buffer (PH 7.0), into which the membrane is inserted and left for 1 or more hours. The amino groups of the enzyme and the aldehyde groups of the membrane surface react to form Schiff's base and the enzyme is immobilized on the membrane surface. This membrane is taken out of the solution and cleansed with an 0.1 M phosphate buffer.

For storage, the membrane is placed in an 0.1 M phosphate buffer and refrigerated.

### 3. Preparation of Enzyme Sensors

(1) An enzyme membrane prepared by the above method is attached firmly to the Teflon membrane of the Clark oxygen electrode, which is covered by a multiporous Teflon membrane (in the case of an alcohol sensor) or a cellulose dialyzing membrane and fixed with an O-ring (Figure 8).

(2) The electrode is inserted into a flow-cell, where an 0.1 M phosphate buffer is transmitted.

(3) Wires are bound, as shown in Figure 4, and this instrument is left untouched until a stationary current is obtained. When it has reached a fixed value, a prescribed concentration of glucose or ethanol is added, and the change in current is measured (the value is recorded by a recorder).

(4) A standard solution of a prescribed amount of glucose (or ethanol) is prepared. This solution is applied to produce a calibration curve based on the relationship between the responded amperage and the concentration of glucose or ethanol.

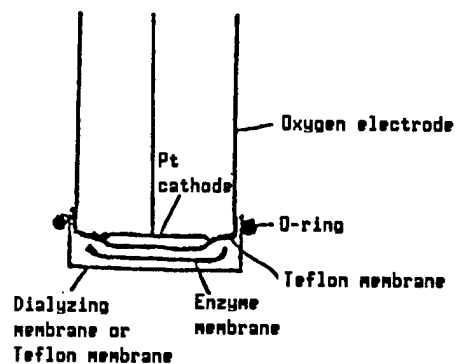

Figure 8. Structure of an Oxygen Electrode

(5) Sample solutions of the same concentration are inserted into a large number of sensor systems and the reproducibility of measurement is studied.

(6) With a commonly sold beverage used as the sample solution, glucose or alcohol concentration is measured by the sensor. If possible, the measurement is also conducted with conventional methods and the values obtained by both methods are compared.

#### References

1. Ikuo Karube, Atsuo Tanaka, and Ryuichi Matsuno (edited by Saburo Fukui), "Bioreactors," KODANSHA SCIENTIFIC, 1985.
2. Ikuo Karube, "New Biotechnology," Ohm-sha, 1986.

20140/9365

## COMPUTERS

Information Project/FY88/MITI

43065128 Tokyo DENSHI KOGYO GEPP0 in Japanese Feb 88 pp 2-13

[Article by Motoya Nakae, Electronics Policy Division, Machinery and Information Industries Bureau, Ministry of International Trade and Industry]

[Text] Introduction

Use of information technologies in Japan has been on the rise, as witnessed by the fact that now there are over 250,000 general-purpose computers in operation and that over 65 percent of the businesses have online information access capabilities. It is anticipated that the waves of information technologies will spread from industry to society at large, as well as to homes. An important trend will be increasing personalization of information use and access.

In the coming information society, all fields of human activities will be connected by information networks; in such a society people will be able to enjoy a myriad of desired services anywhere and anytime, by means of sophisticated information processing systems. In such a society, advanced computer systems will be integral parts of various economic, social, and cultural activities, making for a richer standard of life for all.

The information industry has grown to Y15 trillion in size, and has become a major industry in Japan. This industrial segment should continue to grow by leaps and bounds. As stated in a report issued by the Long-Term Outlook Group of the Information Industry Division of the Industrial Structure Council, by the year 2000 the information industry will grow to Y126 trillion in size, representing almost 20 percent of the GNP. Thus, this will be a leading industry ushering in the 21st century.

In the past the use of information technologies in Japan has been mainly concerned with quantitative expansions resulting from breath-taking technological innovations. Much remains to be addressed in the areas of infrastructure and qualitative aspects of information technology utilization. To realize an advanced information society, it is necessary to provide appropriate answers to these issues.

Taking cognizance of these facts, during FY 1988 as in prior years MITI will continue to undertake and pursue comprehensive information-related policies and programs.

In the following I will describe MITI's information-related policies and programs, including new programs that are to be initiated.

Education and Human Resources Development Relating to Information Technologies  
The spread of information technologies requires the development of personnel resources and the promotion of computer utilization in schools, in order to meet the diversifying and more complex information processing needs of industry and society and to provide the human resources necessary for supporting the use of information technologies.

During FY 1988 MITI will pursue further development of the information university concept and implement programs for the promotion of information education and human resources development.

#### 1. Development of the Information University Concept

A shortage of software engineers has led to a mushrooming of information-related training institutions and vocational schools, with resulting expansion in the field of information processing education. This has created a widening disparity among these schools as to the contents of the training offered and the qualification of instructors, bringing to the surface the problem of quality of personnel trained by these schools. To address this problem, MITI will continue to pursue the concept of an information university, with the goal of developing high quality information processing technicians and the vitalization of regional information industries.

##### (a) Information University Concept

The Central Information University, established in last June, will conduct surveys on software technology education methods, train instructors for regional information colleges, and will commission by contract organizations for the coordination of information personnel training activities (regional information colleges) at various locations in the country. The purpose of this program will be to promote the education of technical personnel at the local level and to ensure the development of highly competent personnel to fulfill the needs of industries.

<Budget> Promotion of the Information College Concept: Y84 (million) (Y68 million)

Note: The figures inside parentheses are FY 1987 budget figures.

(Reference)

Percentage of Candidates Passing the Category 2 Information Processing Technician Examination (unit: percent)



Classification	1986	1987
Graduate schools	53.7	54.8
Universities	24.3	22.8
Vocational schools	9.9	11.0
Average	13.1	13.0

(b) Courseware for information processing technicians (CAROL system development)

In view of the current shortage both in quality and quantity of information processing technicians (systems engineers, senior programmers, etc.), as part of the information university concept, software for the training of information processing technical personnel, consistent with the needs of the industry, will be developed and disseminated.

Specifically, the project calls for the development of specifications for computer-assisted instruction (CAI) systems for information processing personnel (CAROL system), definition of standard curricula for the training of information processing personnel, and dissemination of the CAROL system.

<Financial Investments> Industrial investment outlay for the development of information processing personnel training courseware: Y900 million (Y600 million)

## 2. Promotion of Computer Utilization in Classrooms

In view of the rapid growth of information technology utilization in society, it is necessary that a wide spectrum of the population has ready access to computers and other information-related equipment (promotion of computer literacy). Therefore, it is desirable that computers are incorporated into classrooms so that school children will be able to use computers as everyday tools.

Further, the use of computers in classrooms should enrich the educational methods that are at the disposal of teachers.

In recognition of these needs, through the efforts of the Information Processing Promotion Association (IPA) and the Computer Education Development Center Foundation, MITI will undertake programs to promote computer utilization in schools.

(a) Basic Research and Survey on Information Processing for Educational Purposes

To help promote the use of computers in classrooms, research, development, and surveys will be conducted concerning the design of user-friendly computers for educational purposes.

<Budget> Basic Technology Survey for Educational Purpose Information Processing: Y240 million (Y220 million)

(b) Development of Teaching Materials Preparation Support Systems

An important requirement of computer education teaching materials (courseware) is that they sufficiently reflect the intent of the teacher actually teaching the class. For this reason, the development of a system for assisting in the preparation of courseware for teachers not yet well versed in courseware preparation will be conducted as an continuing effort, following the efforts carried out during 1987.

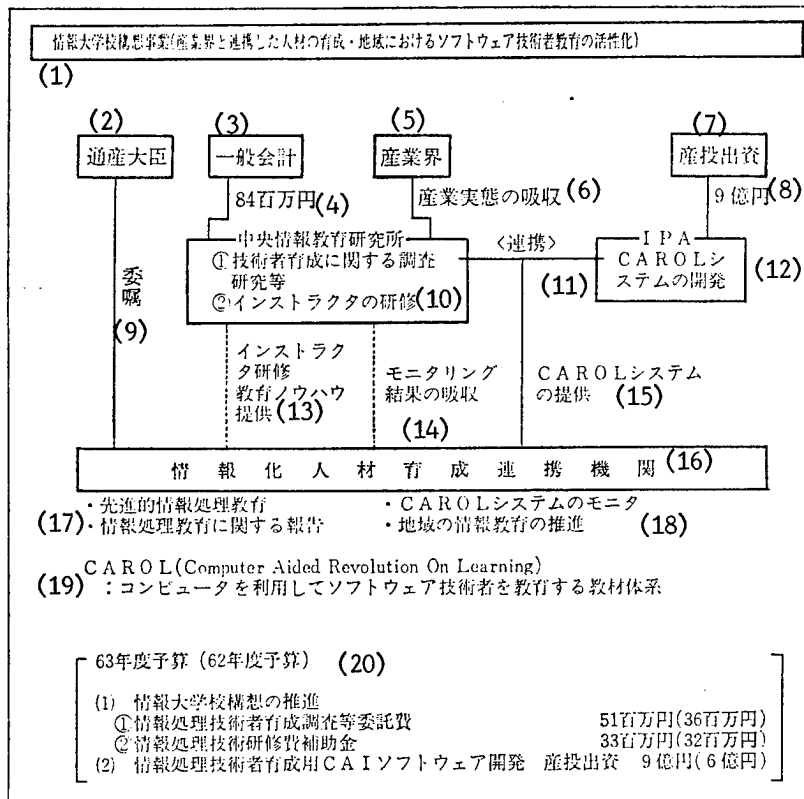

Figure 1 Information University Concept Program

Key:

1. Information University Concept Program (personnel resources development in close coordination with industry; vitalization of software technical education in the regions)
2. Minister of MITI
3. General account
4. Y84 million

5. Industry
6. Acquisition of knowledge on "what is real in the industrial world"
7. Industrial Investments
8. Y900 million
9. Contract
10. Central Information Education Research Institute
  - (1) Research and investigation concerning the training of technical personnel
  - (2) Training of instructors
11. Tieup
12. IPA
  - CAROL system development
13. Instructor training
  - Provision of educational know-how
14. Monitoring and feedback
15. CAROL system furnished
16. Allied organization for information-related personnel development
17. Advanced information processing education
18. Monitoring the CAROL system performance
  - Promotion of information education at the regional level
19. Computer-assisted teaching material development system for the training of of software
20. 1988 budget (1987 budget)
  - (1) Implementation of the information university concept
    - (a) Contracted surveys on information processing personnel development Y51 million (Y36 million)
    - (b) Training subsidies to information processing personnel Y33 million (Y32 million)

- (2) Development of CAI software for the training of information processing technical personnel

Industrial Investment: Y900 million (Y600 million)

This program will be carried out by the Computer Education Development Center Foundation, supported jointly by MITI and the Ministry of Education.

<Financial Investment> Information Education and Human Resources Development Program - Industrial Investment Outlay: Y900 million (Y600 million)

#### Comprehensive Software Promotion Programs

A stable supply of high-quality software is essential to the realization of an advanced information society. The rapid growth in the utilization of information technologies and the rapid spread of computers have led to an explosive growth in the demand for software. On the other hand, there is a chronic shortage of information processing technicians needed for the development of software. It is conceivable that the gap between demand and supply will widen further in the future; if the situation is not remedied, irreparable damage could arise. Exacerbating this problem is the steady increase in the proportion of software-related costs in the total costs of information processing. Also, the demand for software reliability and quality has become increasingly stringent. Thus, the environment surrounding software development has become more demanding.

To provide for these needs, IPA, the core organization for the execution of software-related programs, will continue to implement the Sigma program, make best use of the program reserve fund system essential to the generalization of software programs, and undertake such other programs as necessary for comprehensive promotion of software development and use.

#### 1. Programs of the Information Processing Promotion Association

This organization will carry out the following programs related to the building of a software production industrialization system (Sigma system), started in 1985 and intended to achieve a quantum leap in productivity and reliability in software development.

- (a) Software production industrialization system program

(Sigma program)

<Financial Investment> Industrial investment: Y2.9 billion (Y2.9 billion)  
the Japan Development Bank loan: Y600 million (Y500 million)

- (b) Program development interchange promotion program

<Financial Investment> Industrial investment: Y1.5 billion (Y1.5 billion)

(c) Information education and personnel development promotion program

<Financial Investment> Industrial investment: Y900 million (Y600 million)

(d) Low-interest loans to support the development of systems to be used jointly by multiple businesses

<Financial Investment> Government-guaranteed loan: Y1.5 billion (Y1.8 billion)

(e) General account programs of the Information Processing Promotion Association

<Budget> Information Processing Promotion Association program funds: Y1.2 billion (Y1.35 billion)

## 2. Loans for the Promotion of Information Processing (the Japan Development Bank loans)

Loans will be provided to support the automation of software development, training of software development technicians, and the development of software for information processing systems to be used by corporations on a shared basis will be made. The loans will be for the acquisition of both facility-related and non-facility-related resources.

Interest rates will be at Special Interest Rate 5 (5.20 percent as of January 1987), which is the most preferred rate, and Partially Special Interest Rate 4 (5.40 percent as of January 1987).

<Financial Investment> Part of the Y110 billion ceiling for the promotion of information technologies (part of Y86.5 billion)

Promoting Network Utilization and Augmenting the Infrastructure for User-Oriented Information Utilization

### 1. Support of Personalization of Information

- "FRIENDS 21" (Futuristic Distributed Information Processing Environmental Base Technology Development)

Essential to the promotion of an advanced information society is the availability of a man-machine interface allowing a wide segment of the population to interact with information systems in an individualized, diversified manner, and the realization of widely distributed information processing systems.

The current generation of computers requires the services of specialists to exploit their full capabilities; also these computers are ill-equipped to handle free-format data and analog data. If this situation is left unattended, there will be many people not prepared to use information equipment, to the detriment of economic efficiency.

To deal with the above problems and to realize the personalization of information, i.e., widely distributed processing environment, the development of the following capabilities, difficult to achieve with the current information processing technology, will be undertaken: (1) graphics and other analog data processing; (2) technology for processing the Japanese language and "fuzzy" data; and (3) human engineering-oriented interface.

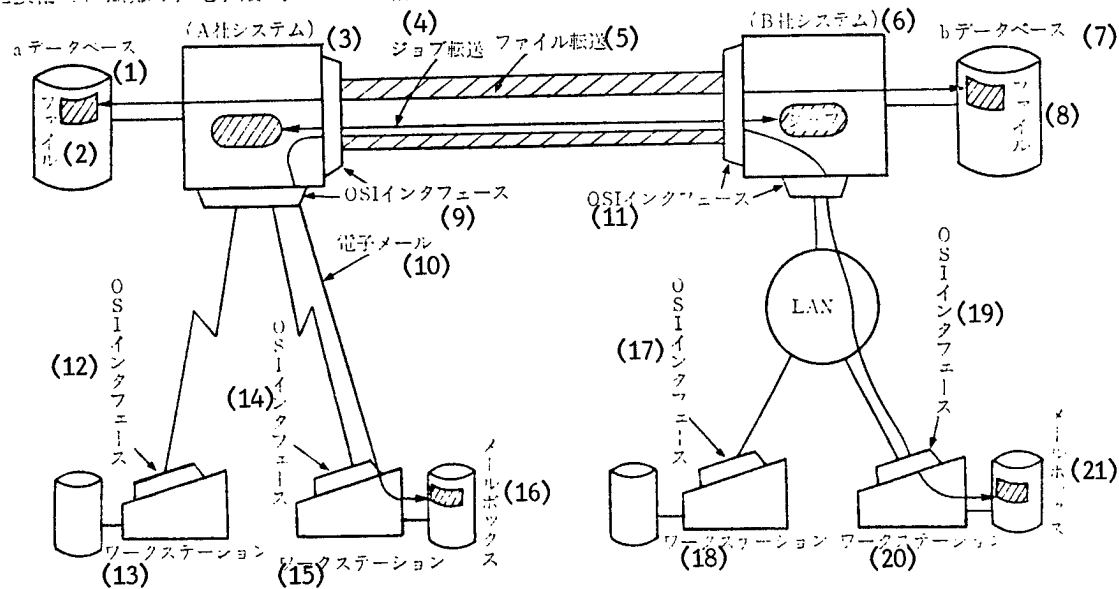

Figure 2. OSI Concept

Key:

- |                     |                   |
|---------------------|-------------------|
| 1. Database a       | 12. OSI interface |
| 2. File             | 13. Workstation   |
| 3. Company A system | 14. OSI interface |
| 4. Job transfer     | 15. Workstation   |
| 5. File transfer    | 16. Mail box      |
| 6. Company B system | 17. OSI interface |
| 7. Database b       | 18. Workstation   |
| 8. File             | 19. OSI interface |
| 9. OSI interface    | 20. Workstation   |
| 10. Electronic mail | 21. Mail box      |
| 11. OSI interface   |                   |

This project is aimed for practical utilization by the second half of the 1990's. Developmental efforts will be conducted over a course of six years, until the year 1993.

<Budget> General account: Y100 million (new start)

## 2. Interoperability of Information-Related Systems

The growth in information and communication technologies has increased the degree of interconnection between computers. From the standpoint of ensuring the smooth advancement of information technology utilization and ensuring free competition among equipment and systems makers, there is a strong demand for interoperability of information equipment and systems.

For the purpose of ensuring interoperability at various levels, such as hardware and software, work is under way toward the unification of industry-level business protocols (conventions for application-specific information exchange and processing) at the International Standards Organization (ISO). To promote open system interface (OSI), efforts will be carried out in the following areas: implementation of OSI in terms of JIS (Japan Industrial Standards), development of advanced technology for ensuring interoperability, international coordination, and related multi-faceted efforts.

In view of the pressing need for timely standardization of equipment and in a manner consistent with the pace of technology development, efforts will be made to speed up the publication of JIS draft proposals. Similar forward-looking, dynamic standardization programs will be pursued. At the same time, MITI will actively pursue international standardization activities through ISO.

### (a) Promotion of OSI

#### (1) Promotion of OSI through International Coordination

a. Execution of government-based international coordination efforts, including convening high-level meetings between Japan and the EC concerning the promotion of OSI, and convening meetings of experts.

b. Promotion of coordination between POSI (Japan), SPAG (ES), and COS (U.S.), which are private sector-level organizations for the promotion of OSI.

#### (2) Undertaking the implementation of compatibility tests to be administered on OSI-based products

Information Processing Interoperability Technology Association (INTAP) is now studying the possibility of conducting compatibility tests on OSI-based products such as information processing equipment. In September 1987 they established an OSI test and certification center within INTAP. The next step will be actual testing of a standard test and certification system to determine whether or not OSI-based products will actually operate according to OSI protocols.

#### (3) Research and Development of Interoperable Computer Database Systems

Essential to the realization of an advanced information society is the construction of large-scale database systems that are interoperable and permit efficient operation of characters, drawings, graphs, voice, and other

multi-media data by means of different types of interoperable information processing devices.

Toward this goal, the R&D of "Interoperable Computer Database Systems," started in 1985 as part of the Large-Scale Projects, will undertake full-scale design and prototype development of multimedia technology, distributed database technology, high reliability technology, and other high-level, advanced information system technologies.

In particular, in OSI-related efforts the following projects will be undertaken:

- a. Creation of OSI standard subsets and development of functional standards
- b. Demonstration and evaluation of model systems

<Budget> R&D of Interoperable Computer Database Systems (Large-Scale Projects): Y1.14 billion (Y1.04 billion)

(b) Development of Common Interface

From the standpoint of realization of an advanced information society and expansion of domestic demand, it is necessary to promote the spread of information technology utilization by individuals and in homes.

Toward this goal, the utilization of common software resources through a variety of information-related devices (ensuring portability) and other efforts will be made to ensure compatibility between different pieces of information equipment.

<Industrial Investment> Part of Y5.3 billion (new start)

Development of Information-Related Technologies

If the Japanese economy is to realize a vigorous advanced information society and to provide for the diverse needs of industry and society, continued technology development is essential.

Therefore, the following developmental efforts will be continued during 1988 in a vigorous manner: the Fifth-Generation Computer, essential to the advancement of information utilization; interoperable computer database systems; supercomputers for scientific/engineering computations; and advanced social systems. In addition, the research and development of FRIEND 21, superconducting devices, and superconducting materials will be undertaken as new initiatives.

Further, efforts will be made to ensure active utilization of the loan financing function of the Basic Technology Research Promotion Center and measures will be adopted to promote the research and development activities of R&D companies established with funding from the Center.

Equally important as part of the further development of Japan's already high technology development capability moving toward the 21st century is to make



contributions to international society. Thus it is important to augment the basic ingredients for research, such as large-scale R&D facilities, to augment R&D in basic and advanced fields, and to strengthen international research cooperation, all in an integral manner.

Therefore, three new programs have been added to the New Energy Development Organization (NEDO): (1) research infrastructure improvement program, (2) research and development program, and (3) international research cooperation program. To reflect these changes, the Organization has been renamed the "New Energy and Industrial Technology General Development Organization" (tentative name).

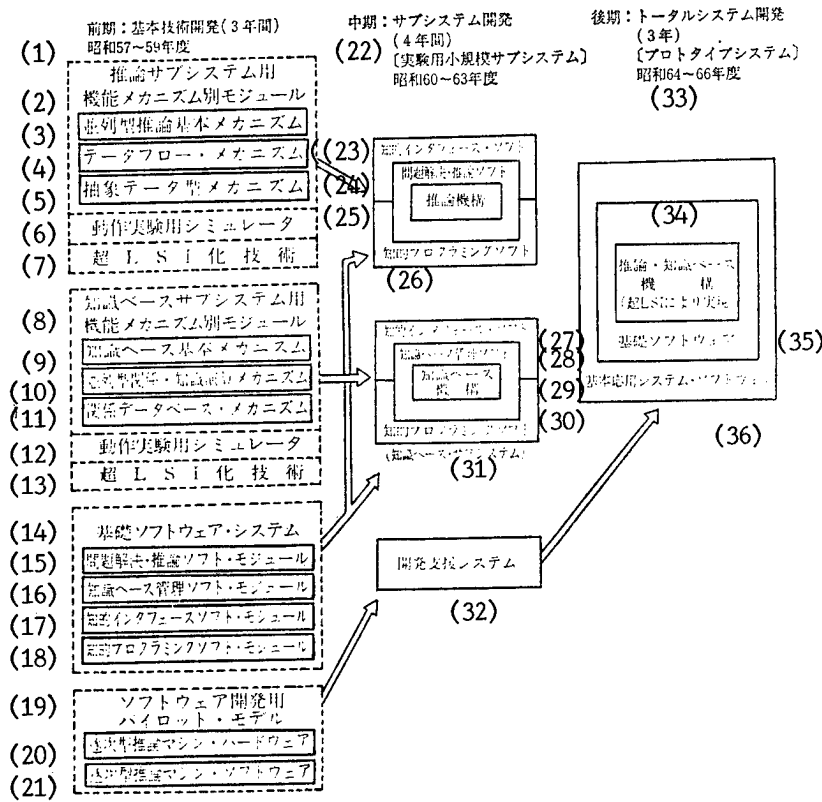

Figure 3 Stages of Fifth-Generation Computer Research and Development Project

Key:

1. First phase: basic technology development (3 years) 1982-1984
2. Functional mechanism modules for the inferential subsystem
3. Basic mechanism for parallel inference operation
4. Dataflow mechanism

5. Abstract data-type mechanism
6. Operation experiment simulator
7. VLSI technology
8. Functional mechanism modules for the knowledge base subsystem
9. Basic mechanism for the knowledge base
10. Parallel relational and knowledge computation mechanism
11. Relational database mechanism
12. Operation experiment simulator
13. VLSI technology
14. Fundamental software systems
15. Problem solving, inferential software modules
16. Knowledge base management software module
17. Intelligent interface software module
18. Intelligent programming software module
19. Pilot model for software development
20. Sequential inference machine hardware
21. Sequential inference machine software
22. Middle phase: subsystem development (4 years)  
(Experimental small-scale subsystems)  
1985-1988

#### 1. R&D of Fifth-Generation Computers

Continuing, vigorous efforts will be made in R&D of a new generation of computers (Fifth-Generation Computers) using artificial intelligence, advanced parallel processing, and other innovative technologies, with the goal of realization early in the 1990's.

During 1988, the final year of the middle phase of the project, experimental production of systems for the realization of driver subsystems and knowledge base subsystems will be carried out (see Figure 3).

<Budget> General and special accounts: Y5.73B (Y5.63B)

2. Futuristic Distributed Information Processing Environmental Base Technology Development (FRIEND 21) (Described earlier)

<Budget> General account: Y100 million (new start)

3. R&D of Interoperable Computer Database Systems (Large-Scale Projects) (Described earlier)

<Budget> General and special accounts: Y1.14 billion (Y1.05 billion)

4. Development of a Supercomputer System for Scientific and Engineering Computations (Large-Scale Projects)

Continuing efforts will be made in research and development of a high-speed computer system for scientific/engineering computation of image data transmitted from weather satellites and similar data.

<Budget> General and special accounts: Y2.78 billion (Y2.95 billion)

5. New Functional Devices

Following the work carried out on superlattice devices, three-dimensional circuit devices, and biodevices, research and development efforts will be sustained to explore innovative, basic technologies to extend the current limits of technology and to lay a new foundation for high technology industry.

<Budget> General account: Y1.21 billion (Y1.4 billion)

6. Superconducting Devices and Materials

New R&D efforts will be undertaken to elucidate the mechanism of high-temperature superconducting materials, to search for room temperature superconducting materials, to develop innovative processing technologies, and to develop new functional devices using high-temperature superconducting materials.

<Budget> General and special accounts: Y1.06 billion (new start)

7. Optical Reaction Materials

The goal of this program is to establish basic technologies relating to optical reaction materials capable of undergoing reversible changes in molecular structure and aggregate states mediated by the action of light, which could be used for applications such as super high density data recording, high-resolution display, and optical switching.

<Budget> General account: Y230 million (Y180 million)

#### 8. Development of Diagnostic Aid Systems

Continuing efforts will be made in the development of a consultation system for direct support of diagnostic tasks of the doctor in order to promote increasing use of information technologies in the medical diagnosis field, to raise the level of medical care, and to increase the efficiency of the same.

<Budget> General and special accounts: Y370 million (Y170 million)

#### 9. Active Use of the Basic Technology Research Promotion Center

The Basic Technology Research Promotion Center is an organization for providing risk coverage funds to promote testing and research conducted by private firms in the area of basic technology.

During FY 1988, the Center will provide funding to the Joint Testing and Research Corporation and the New Media Community Concept Promotion Corporation, provide conditional, interest-free loans, and provide referral service between private businesses and national research institutions. Continuing efforts will be made in these areas to promote technology development efforts.

<Financial Investment> Direct program funding: Y19.2 billion (Y17.3 billion); program support by means of loans: Y6.8 billion (Y7.7 billion)

#### Improving the Use of Information Technologies in Industry and the Information Technology Infrastructure

The use of information technologies in the industrial sector has been fueling increased use of information resources in the rest of Japanese society. In the future, it will be necessary to develop inter-industry information processing systems and other forms of information technology utilization that cut across corporate and industrial boundaries. Toward this goal, MITI will establish "Guidelines Concerning Shared Use of Computers" pursuant to the Information Processing Promotion Law. In addition, it will continue to provide low-interest loans through IPA.

The Japan Development Bank and Hokkaido & Tohoku Development Corporation will provide loans designed to expand the use of system technologies and communication systems; these organizations will establish new loan ceilings to promote safety in the information processing arena in order to build a foundation for an advanced information society.

These organizations will expand the list of programs eligible for interest-free loans, such as the New Media Community concept approved during the 1987 supplementary appropriation process, and other programs related to the creation of social capital assets.

In order to achieve an economic growth consistent with the growth potential of the Japanese economy and to lay the foundation for medium and long-term

growth, MITI will establish preferential tax measures relating to information-related capital investments, which are considered stable components of the domestic demand.

#### 1. Promotion of Systems Integration Services

To improve the information technology foundation for the Japanese economy, it is essential to provide system integration services to enable the information service industry, central bearer of the information base, to meet diverse user needs.

Toward this goal, MITI will allow tax-free savings for maintenance and guarantee reserves to be used by personnel engaged in the construction and delivery of information services which meet certain minimum requirements and which offer free maintenance and guarantee contracts. Also, MITI will provide funding through the the Japan Development Bank for system integrators who contribute to the strengthening of the foundation for information industry and who provide systems that are of significant benefit to the public.

<Financial Investment> Funding from the Japan Development Bank: part of Y5 billion (new start)

<Tax Code> Establishment of an integrated system maintenance reserve system

#### 2. Promotion of a Network Society

To improve and vitalize the industrial structure of Japan and to realize an information society sustaining comfortable, fulfilling living for all, it is necessary to speed up the construction of networks for information processing and to build an infrastructure to support increasing use of information technologies by industry.

Toward this goal, MITI will provide preferential tax treatments to persons acquiring network construction facilities.

<Tax System> Multimedia multiplexing devices and image compression devices will be added to the list of eligible devices under the "Tax Code for the Promotion of Investments in Energy, Society, and the Economic Infrastructure."

#### 3. Information Processing Safety Assurance Facilities (establishment of backup centers)

Given that the Japanese socio-economic society is highly dependent on the operation of computer systems, ensuring the reliability and safety of computer systems is an urgent, essential task from a public welfare as well as industrial standpoint.

Toward this goal, loan assistance will be provided by the Japan Development Bank for strengthening user information system safety measures and for the establishment of backup centers. Also, interest-free NTT loans will be provided for establishment of information processing backup centers in new media community regions.

Also, backup center facility costs will be added to the list of eligibles under the small business and infrastructure augmentation tax code, to allow a special 30-percent depreciation allowance or a 7-percent tax writeoff.

<Financial Investment> Information promotion ceiling: part of 110B yen (new start)

<Interest-Free Loans by NTT> Promotion of construction of backup centers (new start)

<Tax> Backup center facilities will be added to the list of eligibles under the "Small Business Infrastructure Augmentation Tax Code."

#### 4. Accelerating the Dissemination of High-Vision TV Technology

Because of its high resolution graphics and wide-angle screen capability, high-vision TV has a high potential as the next generation of TV technology and has a high application potential for public service fields. Therefore, it is important to ensure a steady spread of this technology.

To support the spread of high-vision technology in the private sector, starting in FY 1988 MITI will establish a system of funding assistance and loans from the Japan Development Bank for entrepreneurs engaged in the promotion and dissemination of high-vision-related equipment and software.

<Financial Investment> Information promotion ceiling: part of 110B yen ceiling (new start)

Investment ceiling: part of Y5 billion ceiling (new start)

#### 5. Programs Related to Damage by Electromagnetic Waves

To promote the technology for the prevention of damage from electromagnetic waves, an important part of industrial technology, the Japan Development Bank will provide loans to persons who acquire facilities (electromagnetic wave-reflecting rooms, electromagnetic wave-shielding rooms, etc.) for the prevention of electromagnetic wave damage.

<Financial Investment> Information Promotion Ceiling: part of Y110 billion (new start)

#### 6. Promotion of Increasing Use of Information Technologies in Specific Industries

Shared use of computers in industries has been advancing from intracorporation to intercorporation, and the trend is growing rapidly. In addition to studying the industry-by-industry role of information technology utilization and promoting the formation of a consensus approach within industries, MITI will establish "Guidelines for Shared Use" pursuant to the "Law Concerning the Promotion of Information Processing." During 1987, MITI established

guidelines for the electric and furniture industries; work is currently progressing on guidelines for the electronics and machinery industry; during 1988, MITI will conduct studies on the machine tool and other industries.

#### Construction of Futuristic Information-Oriented Cities

To accelerate the realization of an advanced information society and to promote domestic demand, it is necessary to accelerate financial investments to encourage greater use of information technologies in industries, homes, and society at large.

Toward this goal, MITI will define the fields in which novel information systems are to be built and introduced in model cities during the 21st century. MITI will also promote the construction of network systems for increased use of information technologies in various fields. These efforts are intended to trigger wider use of information systems in society.

During 1988, following the efforts carried out in the previous year, MITI will undertake the necessary financial investment and tax code measures, and will carry out the construction of futuristic cities in a vigorous manner (Figure 4 - omitted).

<Budget> Research on the construction of area management systems for multi-media information processing: Y100 million (Y30 million)

<Financial Investment> Construction of an infrastructure for regional development infrastructure for international information processing; construction of facilities for comprehensive area management systems the Japan Development Bank loan ceiling for urban redevelopment: part of Y1.1 billion (part of Y85 billion)

Part of Y5 billion investment outlay (part of Y11 billion)

Part of the Y145 billion loan ceiling by the Hokkaido & Tohoku Development Corporation (part of Y135 billion)

<Interest-Free Loans by NTT>

<Tax System> Pursuant to the Private Sector Utilization Law, the following tax provisions will be established for the above types of facilities:

(1) A special depreciation allowance of 20 percent in addition to the regular depreciation allowance during the first year of a facility acquisition.

(2) Reductions in business income tax and other local taxes, similar to the tax advantages enjoyed by other Private Sector Utilization facilities.

#### Promotion of Regional Information Technology Utilization

To ensure the orderly realization of an advanced information society, it is essential to promote increasing use of information technologies throughout the country while narrowing regional differences in information utilization.

Toward this goal, MITI will apply and promote expansion into regions of new media community concepts for the development and dissemination of various information systems attuned to the needs of regional communities. In addition, MITI will promote increased use of regional information technologies by augmenting regional information infrastructure (new media centers) and through active use of financial investment systems for the promotion of increased use of information technologies in the regions.

#### 1. Expansion and Application of New Media Community Concepts

MITI will designate as new media community concepts application and development areas those that are interested in applying model information systems and interested in introducing them in advanced forms. Also, MITI will conduct feasibility studies.

Further, MITI will create databases by developing standard specifications for model information systems constructed in model areas, and will seek further promotion of increased use of information technologies by spreading such databases to similar regions.

<Budget> General account: Y45 million (Y51 million)

#### 2. Augmentation of Regional Information Infrastructure (New Media Centers) Pursuant to the Private Sector Vitalization Law

Regional information infrastructures (new media centers) are expected to play central roles in the increasing use of information technologies in the regions and to contribute to the industrial and economic development of these regions. To promote and augment such centers, MITI will provide appropriate special tax measures pursuant to the Private Sector Utilization Law, and will provide funding assistance in the form of loans through the Japan Development Bank and Hokkaido & Tohoku Development Corporation for persons or companies constructing such centers.

<Financial Investment> Construction of regional information base infrastructures

The Japan Development Bank loan ceiling for urban redevelopment: part of Y1.1 billion (part of Y85 billion)

Part of Y5 billion investment outlay (part of Y11 billion)

Part of the Y145 billion loan ceiling by the Hokkaido & Tohoku Development Corporation (part of Y195 billion)

<Interest-Free Loans by NTT>

<Tax System>

(1) A special depreciation allowance of 20 percent in addition to the regular depreciation allowance during the first year of a facility acquisition.

(2) Reductions in business income tax and other local taxes, similar to the



tax advantages enjoyed by other Private Sector Utilization facilities.

3. Regional Information Promotion Investment and Loan (Investment and loan by Hokkaido & Tohoku Development Corporation)

To provide for the increasingly diversified and complex needs of regions, reflecting the increased use of information technologies, to eliminate regional differences in the utilization of information technologies, and to introduce and promote advanced, sophisticated information processing and systems, MITI will provide either direct funding or loans for the acquisition of facilities and non-facility services necessary for the construction of systems.

The following systems are eligible under this assistance program: (1) online information processing systems used jointly by multiple businesses; (2) online information systems acquired by purveyors of information processing services or information supply services; (3) systems, such as medical care, transportation, and disaster prevention systems, that are beneficial to society; (4) VAN and information processing CATV systems; (5) videotex systems; (6) regional promotion information processing systems and communication systems (new media community systems).

Starting in FY 1987, loans for supporting non-facility-related funding requirements for categories (1), (2), and (3) above were authorized; and along with the systems under category (6), loans will be granted for software development funding as well as facility funding requirements for these categories.

Beginning in FY 1988, work toward the improvement of the electromagnetic wave environment was added to the list of eligibles.

Loan interest rates will be Special Rate 4 (5.4 percent as of January 1988), Partial Special Rate 3 (5.55 percent), or the Standard Rate (5.7 percent).

<Financial Investment> Part of Y145 billion (part of Y135 billion)

4. Regional Information Infrastructure Improvement Investment and Loan (Hokkaido & Tohoku Development Corporation investment and loan)

To provide multifaceted solutions to the software crisis, and to meet the regional needs for software development, plants and equipment funding, long-term operating funds, and investments will be provided for companies conducting software development in the Hokkaido and Tohoku regions.

The interest rate will be Special Rate 2 (5.6 percent as of January 1988)

<Financial Investment> Part of Y145 billion (part of Y135 billion)

5. Promotion of Regional Information Processing Safety Measures (Hokkaido & Tohoku Development Corporation investment and loan)

With increased use of information technologies, many fields in regional socio-economic activities have become heavily dependent on computer systems;

failure of a computer system could have serious repercussions in such activities.

To prevent such an event and the accompanying confusion, it is necessary to provide backup centers for computer systems.

The interest rate will be Special Rate 4 (5.4 percent as of January 1988)  
<Financial Investment> Y145 billion (new start)

#### 6. Investment in the New Media Community Concept Promotion Corporation of the Base Technology Research Promotion Center

To implement the new media community concept in a vigorous manner, the Base Technology Research Promotion Center will provide funding assistance to corporations promoting the concept in model regions.

<Financial Investment> Part of the Y19.2 billion ceiling of the Base Technology Research Promotion Center (part of Y17.3 billion)

#### Database Services and Improvements in Information Supply Services

Along with hardware, software, and personnel resources, databases are important pillars supporting information society. The availability of databases is prerequisite to the use of information technologies. However, Japan lags behind other countries in database availability. Improvements in this area are sorely needed.

To speed up the construction of databases in Japan, MITI will promote database construction at the private industry level, promote the construction of public databases, promote the training of distributors, widen the channel for providing government-owned databases to private businesses, and undertake such database improvement measures as necessary.

<Budget> Improvement and Promotion of Database/Information Supply Services  
Y79 million (Y84 million)

#### 1. Accelerating the Construction of Important Databases

MITI will undertake developmental planning research toward the construction of databases, such as advanced technology databases (fine ceramics, new materials, etc.), energy, and security, which are important for the growth of the Japanese economy.

#### 2. Construction of Public Databases and Widening the Provision of Government-Owned Databases for Private Sector Use

MITI will continue to build the public databases (technology, patents, small businesses, etc.) necessary for the execution of MITI programs; also MITI will widen the channel for making these databases available to the private sector and will review the conditions under which they can be made available.

### 3. Support of Database Building in the Private Sector

Investments will be provided from the Japan Development Bank to corporations engaged in the construction of databases necessary for the future growth of industrial and social activities. Also, both facility-related and non-facility-related loans will be provided by the Japan Development Bank for database construction efforts.

Also, to reduce the financial burden associated with database building and updating, a database building reserve system is provided.

#### (a) Database building loan (the Japan Development Bank loan)

Under this program, loans are provided to pay for the costs associated with the acquisition of facilities for database building and those associated with non-facility-related requirements, incurred by corporations building databases and providing information supply services.

The interest rate will be Special Rate 4 (5.4 percent as of January 1988)

<Financial Investment> Part of the Y110 billion ceiling for the promotion of information technologies (part of Y86.5 billion)

#### (b) Investment funding for corporations engaged in the building of basic databases (Japan Development Bank investment funding)

The Japan Development Bank will provide investment funding for corporations engaged in information supply services and in the building of the "basic databases" necessary for the advancement of socio-industrial activities and the advancement of regional societies.

<Financial Investment> Part of a Y50 billion investment funds (part of Y11 billion)

#### (a) Database building reserve

Construction of databases will be promoted by the following reserve fund system: funds necessary for the construction of a database will be used as a reserve; 10 percent of the sales (including losses) will be put in a savings account and held for 4 years. Over the course of 4 years equal amounts will be withdrawn (including profits).

### Extending Cooperation to Developing Countries in the Area of Information Technologies

To ensure international expansion of information technology utilization, active cooperation will be extended to developing countries, including the countries in the Pacific Region.

#### 1. Research Cooperation Concerning Machine Translation Systems to Be Used by Neighboring Countries

To promote technical and cultural exchange between Japan and its neighboring countries, and to eliminate the language barrier between the Japanese and local languages, continuing efforts will be carried out for joint research for the development of machine translation systems between the Japanese language on the one hand and Chinese, Thai, Malayan, and Indonesian languages, on the other hand.

<Budget> Y330 million out of the research cooperation promotion aid program and research cooperation program.

## 2. Promotion of International Information Cooperation Center Programs

To promote the use of information technologies in developing countries and to contribute to the economic as well as industrial growth of those countries, training for the development of technical personnel, central to promotion of the use of information technologies, will be provided; also, Japanese technical personnel will be sent to host countries to provide guidance toward increased use of information technologies.

<Budget> Y240 million out of the Technical Cooperation Program Subsidies (Y240 million)

## 3. Software Development and Distribution Infrastructure Development (ODA Sigma) for ASEAN Countries

To increase the opportunities for horizontal division of work between Japan and ASEAN countries in the information industry, this program seeks to improve the software development and distribution system infrastructure through application of the Sigma system.

<Budget> Y10 million (new start)

12743

JT-60 Tokamak Type Test Device Test Results

53062561 Tokyo GENSHIRYOKU IINKAI GEPPU in Japanese No 374, Feb 88 pp 6-10

[Article by Japan Atomic Energy Research Institute: "JT-60 Test Results"]

[Text] In April and May 1987, necessary modifications were performed on the JT-60 test device, including partial graphitization of the first wall, increase of the power supply, and enlargement of the heating unit operating region. After the JT-60 test device performance was thus upgraded, tests were conducted over a period of 4 months, from June 1987 to October 1987, at which time the plasma containment performance was improved due to an increase in plasma current. The tests confirmed that the JT-60 target region (temp: several tens of millions to 100 million°C; the product of plasma density and containment time: about  $2 - 6 \times 10^{19} \text{ m}^{-3} \text{ seconds}$ ) specified by the Atomic Energy Commission was attained with respect to values converted to heavy hydrogen plasma.

1. The JT-60 test device performance was upgraded by increasing the power supply, reinforcing the coil crossovers, and strengthening the control functions. Along with this, stabilization was achieved by the incidence of neutral particles and a noninductive current-driven system (using high frequencies)--which is to be the basic operating system of the next large-size test device--was also introduced. Thus, the discharge of 3,200,000 amperes of plasma current, which greatly exceeded the design value established at the outset of the JT-60 plan, was achieved. Under such plasma current, the electrohydrodynamic safety factor ( $q$ ) reached 2.2 (Table 1 and Figure 1).

Table 1. Upgrading of JT-60 Performance

		Design value		Attained value
		At outset of planning	After upgrading	
Toroidal magnetic field		4.5 T	4.8 T	4.8 T
Plasma Current	Limiter	2.7MA	3.2MA	3.23MA
	Diverter	2.1MA	2.7MA	2.7MA

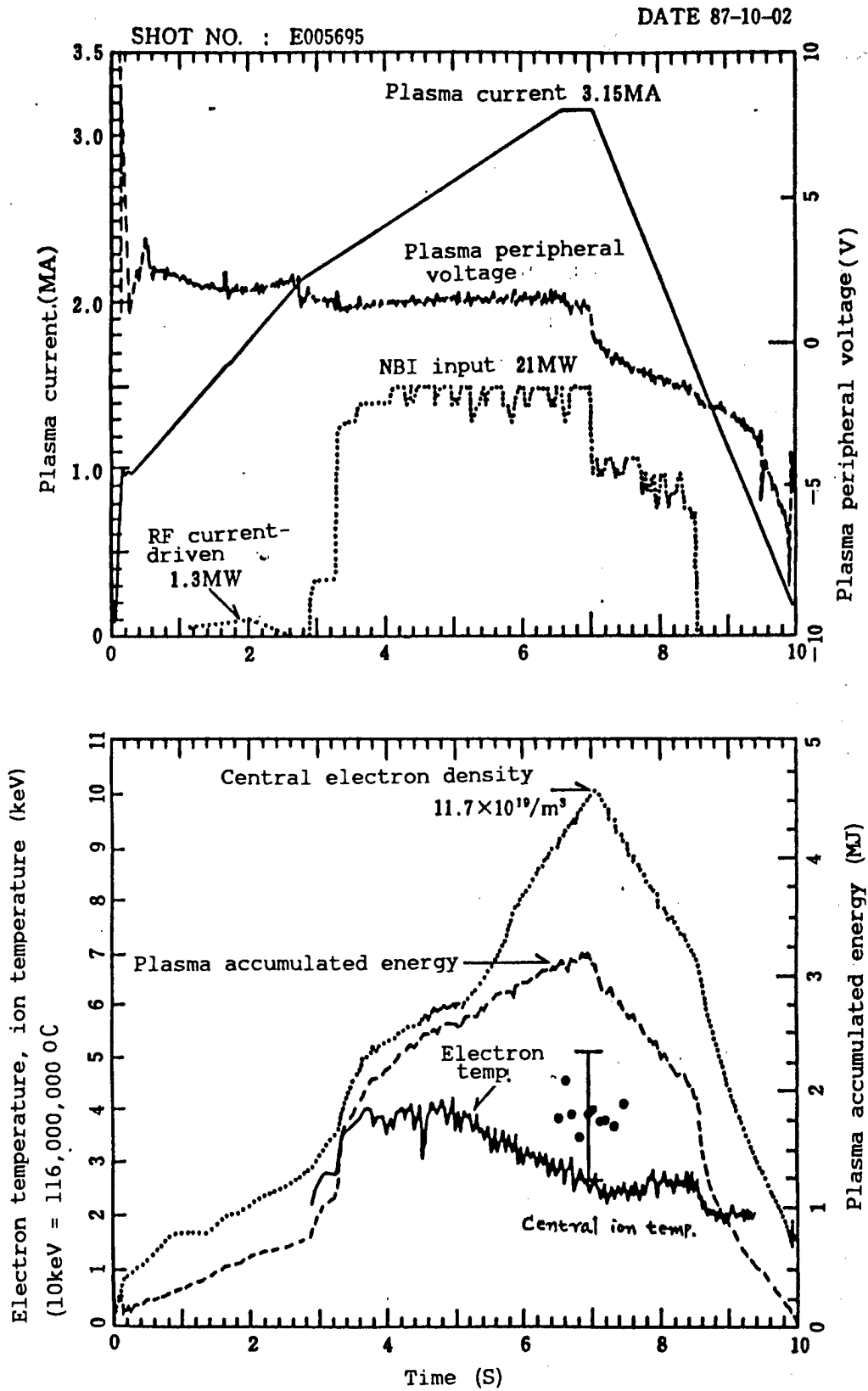

Figure 1. JT-60 high plasma current discharge.

2. With the increase of plasma current, the plasma containment performance was improved gradually. Under a high heating input exceeding 12 MW, a containment time of 0.18 seconds was achieved (Figure 2), greatly exceeding the containment time of 0.12 seconds at plasma current of 2 million amperes discharged up to March 1987.

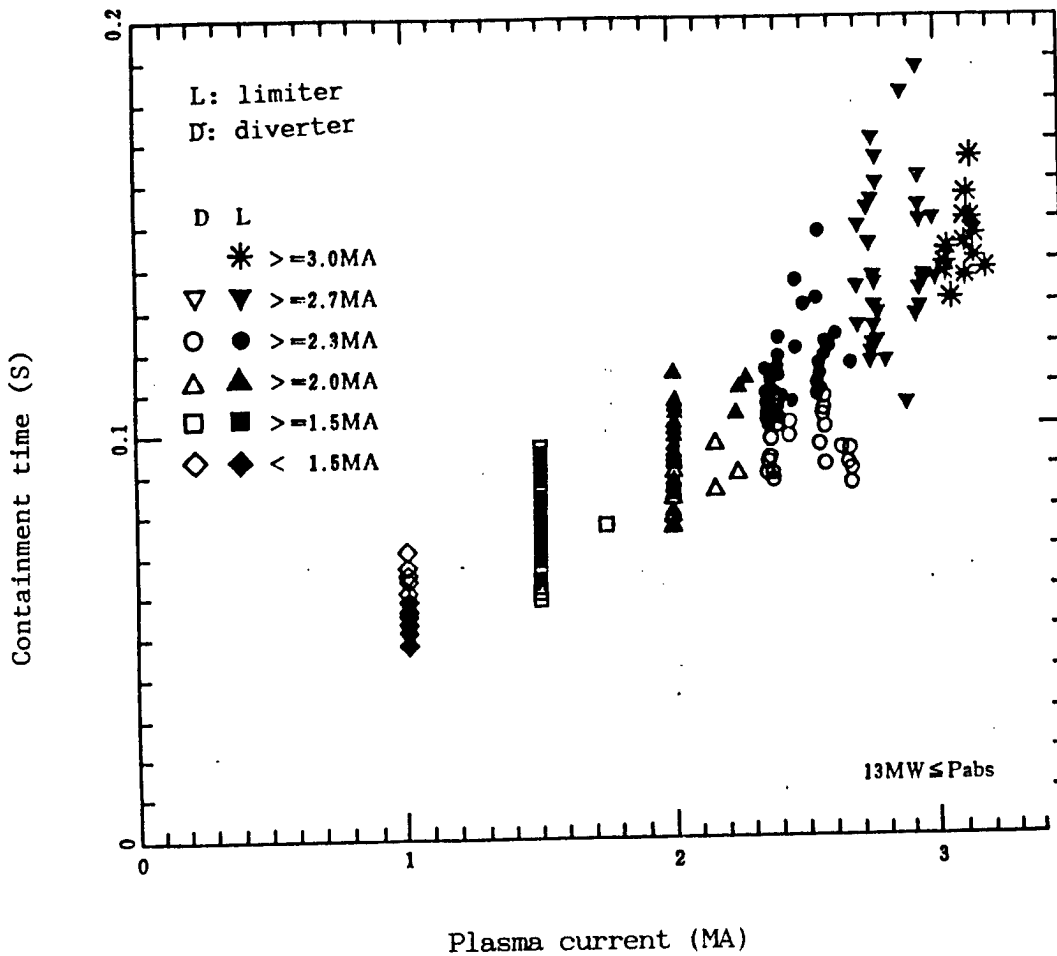

Figure 2. Improvement of containment time due to increase in plasma current.

3. With the improvement of plasma containment performance due to an increase in plasma current, densities, temperatures, etc., were improved, and the data indicated in Figure 3 was obtained. The following highest performance values were obtained at a plasma current of 3,200,000 amperes.

Central density:  $1.2 \times 10^{20} / \text{m}^3$

Central ion temperature:  $43,000,000^\circ\text{C}$

Product of plasma density and plasma containment time:  $1.8 \times 10^{19} \text{ m}^{-3}$  seconds

These performance values are the highest records obtained from hydrogen plasma and are extremely close to the JT-60 target region (black squares given in Figure 3).

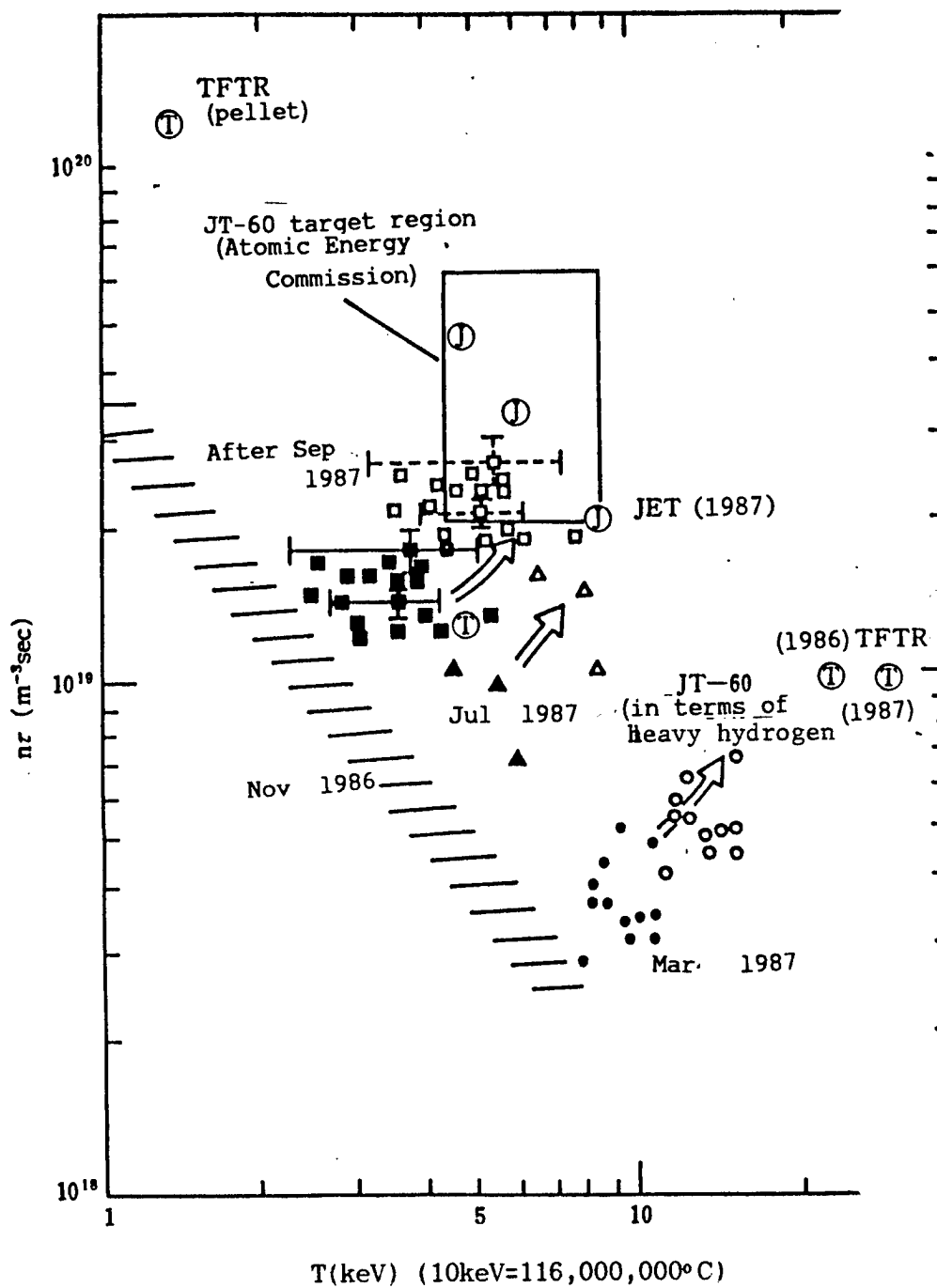

Figure 3. JT-60 target region and attained performance.



4. The plasma containment time increases and the ion temperatures at the same heating inputs rise in proportion to the square root of the nuclear number of hydrogen and heavy hydrogen ions. On the basis of such a test rule, hydrogen plasma was converted to heavy hydrogen plasma and the JT-60 plasma performance values were obtained. It was then confirmed that such plasma values reached the target region (white squares given in Figure 3).

5. Plasma accumulated energy, indicating the total amount of plasma (obtained by multiplying temperature by density), increased with the increase in plasma current and attained a maximum of 3.1 mega joules. With respect to such plasma accumulated energy, the JT-60 test device greatly exceeded the TFTR test device using heavy hydrogen and ranks next to the JET test device. In addition, concerning plasma accumulated energy per unit volume, the JT-60 test device, although using hydrogen plasma, ranks with the TFTR test device using heavy hydrogen and the JET test device (Table 2).

Table 2. Plasma Accumulated Energy and Plasma Energy Density

	JT-60 (Atomic Energy Research Institute)	TFTR (USA)	JET (EC)
Plasma ion	Hydrogen	Heavy hydrogen	Heavy hydrogen
Plasma accumulated energy	3.1MJ	2.4MJ	6.1MJ
Plasma energy density	0.96MJ/m <sup>3</sup>	0.06MJ/m <sup>3</sup>	0.05MJ/m <sup>3</sup>

6. In the JT-60 test device, several phenomena peculiar to highly efficient plasma containment (H mode) were observed concerning both fixed limiter and diverter configurations, in addition to the improvement of the plasma containment performance due to the increase of plasma current.

Thus, the JT-60 device completed a series of test operations on 16 October 1987. Subsequently, the lower diverter coil will be installed, the power supply will be improved to increase plasma current (to 3,500,000 amperes), and a pellet incidence unit will be newly installed. These items of work will be carried out up to February 1988. Test operations will be resumed in March 1988 in order to attain highly efficient plasma containment (H mode) by the lower diverter configuration, to further upgrade plasma containment characteristics by the increase in plasma current, to raise plasma density by pellet incidence, and to improve plasma containment characteristics by density distribution control.

In parallel with these test operations, second-phase planning to achieve a test device having a high performance by the use of a large current system will be started in 1988. Operation of the existing test device, therefore, will be halted for about a year, from 1989 to 1990, to carry out fieldwork.

After the resumption of test operations, tests aiming at discharge of a plasma current of 6,000,000 amperes under the diverter configuration will be carried out in order to attain a plasma performance in the vicinity of the upper limit of the JT-60 target region.

20153/06662

Agreement Reached on Joint Low Level Waste Research

43062060a Tokyo GENSHIRYOKU SANGYO SHIMBUN in Japanese 4 Feb 88 p 1

[Excerpts] The Central Research Institute of the Electric Power Industry held its sixth Nuclear Fuel Cycle Workshop with the U.S. Electric Power Research Institute (EPRI) on 25-27 January at its facilities in Otemachi in Tokyo. They reached agreement concerning the Central Research Institute's participation in joint research on the "Low-level Waste Research Project" begun by the EPRI.

Specifically, they reached agreement on the participation of the Central Research Institute in the "BRC Research Program" (research into low-level waste disposal) which the EPRI began at the request of the U.S. Nuclear Regulatory Commission. Formal signing is expected in the middle of next year.

The BRC Research Program is an investigation into the disposal of low-level radioactive wastes which are generated in great quantities by methods which are economical and rational, but not at the expense of safety. The overall cost of the research will be about Y300 million for the period Jan 88 to Dec 89.

During the workshop at the strong request of the EPRI and the U.S. Department of Energy (DOE), there was also a special session held concerning cast iron casks for spent fuel storage.

During this session, the Central Research Institute presented its research into drop tests and quality assurance and its plans for studies into materials testing. They received high marks from the U.S. representatives.

The EPRI also explained developments in the policy changes at the end of last December in regards to narrowing the U.S. high level waste disposal site down to one site in Nevada.

13008

ADVANCED REACTOR DESIGN SYSTEM TO BE DEVELOPED

43062060b Tokyo GENSHIRYOKU SANGYO SHIMBUN in Japanese 4 Feb 88 p 1

[Text] The Science and Technology Agency has decided that beginning in 1988 it will attempt to develop an Advanced Reactor Design System (ADES) which will use computers to evaluate advanced reactor designs and to perform critical analysis of safety and special features. Thus in April they plan to establish the Select Committee for the Promotion of ADES Development under the Japan Atomic Energy Commission and to push ahead with a five year plan to make a parent research organization for the Japan Atomic Energy Research Institute (JAERI), the Power Reactor and Nuclear Fuel Development Corporation (PNC), and other private-sector and university research organizations. When the system is completed, it will be the world's first large-scale advanced reactor design system.

As nuclear power has developed, there has been a desire to develop safer, highly reliable, economic reactors, to simplify the development steps in reactor design, and to shorten the operational approval process.

As to problems in designing a nuclear reactor, the design process can be divided into three steps, and not only are design and evaluation extremely complex, but we are dependent on the United States for 90 percent of the design and evaluation techniques.

For this reason, in order to demonstrate Japanese creativity and to develop an independent data base, it will be necessary to gather at one location under unified management, all that the various organizations have developed independently.

Accordingly, as a basis for the research and development of creative, innovative atomic power in Japan, they have decided to begin an investigation into the development of an advanced nuclear reactor design system with a systematically upgraded data base, analysis code, computer system, etc.

The objects of the ADES are: 1) to make the design and evaluation of new atomic reactors more efficient, 2) to standardize and shorten the national approval process by evaluating safety and feature analysis through advanced test simulation using computers, and 3) to assist in the creation of new concepts.

In order to study and research the development of this system, the Select Committee For the Promotion of ADES Development will be established under the aegis of the Japan Atomic Energy Commission, and it will: 1) develop a consolidated data base, 2) consolidate the development of software for large-scale, multi-use design, 3) consolidate the development of computer and data processing technology, 4) work on building a system, 5) decide on policies for system operation, etc.

The development period will be five years. Under Phase I, they will attempt to develop a system to make the design and evaluation of new nuclear reactors more efficient, and will: 1) build a data base, 2) consolidate and establish computer methodologies, 3) consolidate the development of a dedicated CAD (Computer Assisted Design) system, 4) develop data processing technologies that use AI (Artificial Intelligence) and supercomputers, and (5) work on building a system.

Under Phase II, they will research and develop advanced simulation technology by working on the upgrading of computer programs, and they hope to reduce the tasks involved in developing a process. To do this, they will push for: 1) the development of techniques to calculate parameters, 2) the development of software for superlarge-scale, superfast computers, 3) the development of simulators for nuclear reactor accident analysis, and 4) improvement of the data base.

Under Phase III, with the goal of developing systems where computers will assist in the creation of new design concepts, they will: 1) perform research into optimizing calculations, analysis, and reasoning, and 2) research and develop creative techniques for analytic reasoning.

The parent research organization will be formed with the collaboration of industry, government, and universities. JAERI will consolidate the data base and analysis coding needed to evaluate the design of high-speed converter reactors, twenty-first century nuclear reactors, TRU quenching reactors, etc., and will cooperate with other countries in the conceptual design of nuclear fusion reactors. The PNC will consolidate the analysis coding and data which has been amassed in developing the fast breeder reactor. The other private-sector and university research organizations will investigate research into new types of reactors.

13008

FUNCTIONAL TESTING ON "MUTSU" SCHEDULED

43062060c Tokyo GENSHIRYOKU SANGYO SHIMBUN in Japanese 4 Feb 88 p 1

[Excerpt] In February the Japan Atomic Energy Research Institute (JAERI) began without delay to inspect the control rod drive wall and to rebuild the power supply rectifiers used in the instrumentation controls on the nuclear powered ship, the "Mutsu," which was launched on 27 January at new harbor of Sekinehama (Mutsu City in Aomori Prefecture).

Then beginning at the end of February they plan to conduct cold condition functional tests in the form of operational tests on various emergency pumps and functional tests on the control rod drive equipment. From the middle to the end of March they plan to conduct hot condition functional tests in the form of various cooling-type functional tests and various control-type functional tests on the control rod drive equipment and pressurizers.

Moreover, although they will use the keys to both the control rod drive wall and the reactor operation mode switch, the reactor will remain shut down.

13008

SHIMIZU CONSTRUCTION ESTABLISHES NEW DEPARTMENTS

43062060d Tokyo GENSHIRYOKU SANGYO SHIMBUN in Japanese 4 Feb 88 p 5

[Text] On 1 February Shimizu Construction established an "Underground Space Development Department" and a "Superconducting Application Technology Development Department" under its main Technology Department.

Shimizu Construction has had experience first in existing urban underground facilities like subways and underground streets and also in underground space development in areas like oil storage in rock formations and large-capacity underground caves. Last year they pushed ahead with joint research with the University of Minnesota's Underground Space Center.

By gathering together all the technicians in this area who have up to now separately pursued their research and development projects in various departments within the company, these underground space development departments will be centralized for the purpose of planning and making proposals on new uses for underground spaces and for technical and commercial development.

They will teach and will participate in the planning and gathering of technical and project information in regard to uses for underground spaces with high incidental value like radioactive waste storage and production facilities.

In order to give advanced underground facilities like high-level radioactive waste management facilities and related technologies an active role in the technical development of underground space utilization, the Science and Technology Agency recently pushed ahead with its "General Underground Development Concept" (the Geotopia Plan.) Shimizu Construction has decided to respond positively to the development of this Geotopia Plan.

On the other hand these departments will have an impact on a number of fields, beginning with superconductivity and nuclear fusion technology and including energy, medicine, traffic, etc.

The Superconducting Application Technical Development Department was created in response to these circumstances. Its purpose will be to accumulate those elementary technologies in the superconducting application field which require advanced construction techniques and to apply them to various kinds of needs. It has been decided that it will be formed from specialized technicians gathered from their Atomic Energy Department, their Technology Department, and their Technical Research Center and that they will teach and will investigate technical and market trends in this field.

## NUCLEAR ENGINEERING

### NUCLEAR POWER GENERATION PLANT UTILIZATION RATE HITS 72 PERCENT

43062060e Tokyo GENSHIRYOKU SANGYO SHIMBUN in Japanese 4 Feb 88 p 6

[Text] According to a study by the Japan Atomic Industrial Forum, the plant utilization rate for January for Japan's nuclear power generating plant operational capacity (including the "Fugen") was 71.7 percent and the rate of time operational was 72.8 percent.

In January five plants began regular inspection one after another, beginning with Tokyo Electric's Fukushima Number 1.4 (BWR, 784,000 KW). On the other hand only two plants resumed operations, one of them being Japan Atomic Power Company's Tokai Nuclear Power Plant, and the utilization rate fell when compared to the previous month.

When the average plant utilization rate is broken down by reactor type, the rate for the 18 BWR plants (output 15.117 million KW) was 82.0 percent, 59.5 percent for the 16 PWR plants (output 12.598 million KW), 24.2 percent for the one GCR plant (output 166,000 KW), and 100 percent for the one ATR plant (output 165,000 KW).

When utilization rate is broken down by company, the rate for Japan Atomic Power (three plants, 2.783 million KW) was 53.5 percent, 48.4 percent for Tohoku Electric Power (one plant, 524,000 KW), 76.6 percent for Tokyo Electric Power (11 plants, 10.196 million KW), 87.2 percent for Chubu Electric Power (three plants, 2.48 million KW), 59.0 percent for Kansai Electric Power (nine plants, 7.408 million KW), 100 percent for Chugoku Electric Power (one plant, 460,000 KW), 69.2 percent for Shikoku Electric Power (two plants, 1.132 million KW), and 80.7 percent for Kyushu Electric Power (four plants, 2.898 million KW).

Of all these, 23 units had plant utilization rates of greater than 80 percent.

Fifteen plants recorded rates of 100 percent beginning with Atomic Electric's Tsuruga Number 1 (BWR, 357,000 KW), and including Tokyo Electric's Fukushima 1.2 and 1.3 and Fukushima 2.1 and 2.4, and Chubu Electric's Hamaoka Numbers 1 and 3.



Figure 1: Average Plant Utilization Rate  
(Dotted line is 1986)

Key: 1) Overall Average for Previous Years 2) Month

-----  
Plant Utilization Rate By Reactor Type

	Number of plants	Output (10,000 KW)	Utilization Rate
BWR	18	1,511.7	82.0
PWR	16	1,259.8	59.5
GCR	1	16.6	24.2
ATR	1	16.5	100
Total	36	2,804.6	71.7

-----  
Plant Utilization Rate By Power Company

Company Name	Number of plants	Output (10,000 KW)	Utilization Rate
Japan Atomic Power	4	278.3	53.6
Tohoku	1	52.4	98.4
Tokyo	11	1,019.6	76.6
Chubu	3	248.0	87.2
Kansai	9	740.8	59.0
Chugoku	1	46.0	100
Shikoku	2	113.2	69.2
Kyushu	4	289.8	80.7
(Fugen)	(1)	(16.5)	100

-----  
PLANT UTILIZATION RATE=  $\frac{\text{Electric Power Generated}}{\text{Approved Output X Calendar Hours}} \times 100$

RATE OF TIME OPERATIONAL =  $\frac{\text{Number of Hours Generating}}{\text{Calendar Hours}} \times 100$

BRIEF OPERATIONS REPORT ON ATOMIC GENERATING PLANTS: JANUARY  
(Compiled by the Japan Atomic Industry Forum)

Plant Name	Type	Approved Output (10,000 KW)	Rate of Time Hours Operational	%	Utilization Rate Generating Output (MWH)	%	Notes
----- Tokai	GCR	16.6	225	30.2	29,838	24.2	Reg Insp#20 (9/26-1/22)
Tokai 2	BWR	110.0	744	100	815,250	99.6	
Tsuruga 1	"	35.7	744	100	265,608	100	
" 2	PWR	116.0	0	0	0	0	Reg Insp #1 (12/17 on)
----- Yasukawa	BWR	52.4	744	100	383,494	98.4	
----- Fukushimal.1	"	46.0	0	0	0	0	Reg Insp#13 (11/20 on)
" 1.2	"	78.4	744	100	583,296	100	
" 1.3	"	78.4	744	100	583,296	100	
" 1.4	"	78.4	216	29.0	166,079	28.5	Reg Insp#8 (1/10 on)
" 1.5	"	78.4	0	0	0	0	Reg Insp#8 (9/5 on)
" 1.6	"	110.0	744	100	806,400	98.5	
Fukushima2.1	"	110.0	744	100	818,400	100	
" 2.2	"	110.0	744	100	816,270	99.7	
" 2.3	"	110.0	460	61.8	465,520	56.9	Reg Insp #2 (10/24-1/22)
" 2.4	"	110.0	744	100	818,400	100	
Kashiwazaki Kariwa 1	"	110.0	696	93.5	754,940	92.2	Reg Insp #2 (1/30 on)
----- Hamaoka 1	"	54.0	744	100	401,697	100	
" 2	"	84.0	534	71.8	388,328	62.1	Reg Insp #8 (1/23 on)
" 3	"	110	744	100	818,301	100	
----- Mihama 1	PWR	34.0	610	82.0	205,435	81.2	Reg Insp #9 (1/26 on)
" 2	"	50.0	744	100	371,720	99.9	
" 3	"	82.6	442	59.4	326,416	53.1	Shut down (12/26-1/13) HDP* Test
Takahama 1	"	82.6	744	100	614,458	100	
" 2	"	82.6	0	0	0	0	Reg Insp #9 (9/14 on)

"	3	"	87.0	744	100	647,224	100
"	4	"	87.0	744	100	647,255	100

(\* HDP= Hold Down Piece)

BRIEF OPERATIONS REPORT ON ATOMIC GENERATING PLANTS: JANUARY  
(Compiled by the Japan Atomic Industry Forum)

Plant Name	Type	Approved	Rate of Time		Utilization Rate		Notes
		Output (10,000 KW)	Hours Operational	%	Generating Output (MWH)	%	
Oi 1	PWR	117.5	0	0	0	0	Reg Insp #7 (12/25 on)
Oi 2	"	117.5	415	55.8	439,585	50.3	Shut down (12/26-1/14) HDP Test
----- Shimane	BWR	46.0	744	100	342,240	100	
----- Ikata 1	PWR	56.6	288	38.7	162,253	38.5	Reg Insp #9 (1-13 on)
" 2	"	56.6	744	100	420,948	100	
----- Genkai 1	"	55.9	0	0	0	0	Reg Insp#10 (11/10 on)
" 2	"	55.9	744	100	415,723	100	
Kawauchi 1	"	89.0	744	100	661,775	99.9	
" 2	"	89.0	744	100	662,077	100	
----- Subtotal or Average		2,788.1	18,766	72.1	14,832,226	71.5	
Last Month		(2,788.1)	(20,439)	(78.5)	(16,427,954)	(79.2)	
----- Fugen	ATR	16.5	744	100	122,760	100	
----- Total or Average		2,804.6	19,510	72.8	14,954,986	71.7	
Last Month		(2,804.6)	(21,183)	(79.1)	(16,549,826)	(79.3)	
-----							

13008

**Telecommunications Terminal System Discussed**

43066549 Tokyo JIDOSHA GIJUTSU in Japanese Feb 88 pp 158-166

[Article by Takahiro Kawazoe, Technical Department, Japan City Media Inc.]

[Excerpts] 1. Foreword

Telecommunication services have recently been playing an increasingly larger role in the daily life of the people in line with the trend toward an advanced information society. In April 1985, the Ministry of Posts and Telecommunications (MPT) promulgated three telecommunications business laws designed to introduce the principle of competition into the telecommunications market by actively using the private sector's ideas, by encouraging the use of radiowaves and by allowing the offering of fine-tuned telecommunications services.

Newcomers entered the telecommunications market one after another. Among Type I telecommunications service providers, Daini Denden Inc., Japan Telecom Co., and Teleway Japan, Ltd., launched leased line services in 1986 and telephone services in the autumn of 1987, while Japan Communications Satellite, Inc., and the Space Communications Corp. are making positive preparations for leased line services using communications satellites.

Mobile communications, which account for about 80 percent of total radio stations, already totaling more than 4 million, are expanding fast and their uses are becoming increasingly diversified, in accordance with the rapid progress in electronics and communication technologies and the development of divergent regional communities.

Typical services provided are, as shown in Table 1, car telephones, radio pages, and multichannel access (MCA) systems. The further development of the advanced information society in recent years has expanded demand for mobile data communications as systems for the high-density collection and processing of information, especially in big cities where economic and human activities are vigorous. Users have great hopes for the development and commercialization of a full-fledged radio data communication service or a telecommunication terminal system.

The Telecommunications Terminal System Study Group met from March to August 1985 at the MPT and carried out various studies and surveys to confirm the

Table 1. Major Mobile Communications Systems

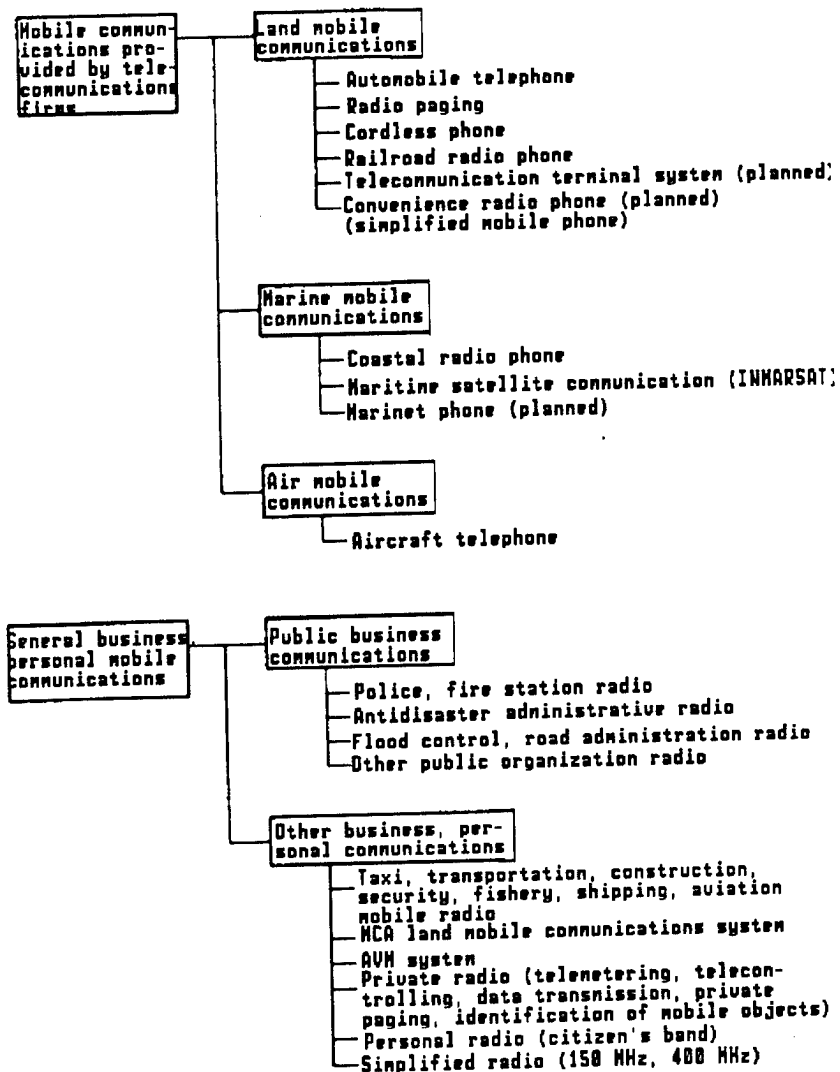

system's feasibility. In its report, the group said the establishment of such a system is highly possible both technologically and economically.

Based on this report, the Council for the Promotion of the Commercialization of the Telecommunication Terminal System, comprising users and makers strongly interested in the system's realization, was set up in January 1986 with an eye to encourage early development of the system, and since then has been conducting surveys and R&D activities. As part of its activities, the council developed a telecommunication terminal pilot system and a plan for conducting various experiments from July 1987 to March 1988 to verify its practicability.

In July 1987, Japan City Media (President: Masao Hirano) was founded to conduct feasibility studies on providing full-fledged, high-quality

telecommunications services at an early date at low cost using the telecommunication terminal system as a Type I telecommunications business.

## 2. Outline of Telecommunication Terminal System

### 2.1 System Outline

The telecommunication terminal system is expected to contribute greatly to the development of the Japanese economy as a new medium for land mobile communications, drastically improving the efficiency of the social economy. The system's basic configuration is shown in Figure 1.

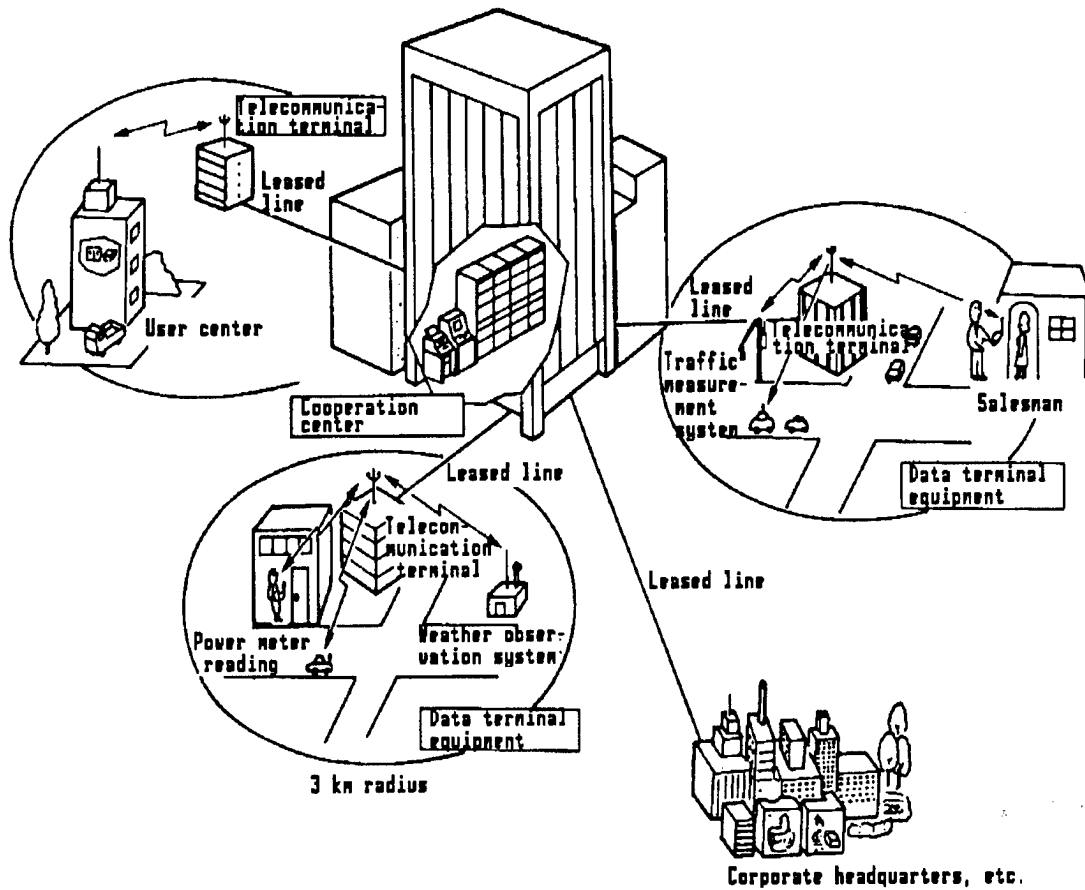

(Concept of telecommunication terminal system)

Figure 1. Configuration of Telecommunication Terminal System

This system is a two-way radio data communications medium that, via telecommunication terminals installed at numerous places in a relatively large city, links portable or mobile radio data terminals carried by salesmen or installed in vehicles and fixed radio facilities, like automatic vending machines, with users' offices and calculation centers.

## 2.2 System's Characteristics

The major features of the system are as follows:

- (1) A small-zone (with coverage about 3 km in radius) data communications system that allows various users to jointly use radiowaves and facilities around the clock.
- (2) Terminals are compact and lightweight, while the cost of the system is low. Service reliability is excellent and various uses (two-way and one-way) are possible depending on applications.
- (3) It can accommodate a great number of subscribers thanks to MCA radio circuit control and data communications using packet switching.
- (4) The system has error correcting and repeating functions to ensure data credibility.
- (5) It has broadcasting, position confirming, and closed area connection functions for diversified services.
- (6) Portable value-added network (VAN) terminals are available by linking the system to a VAN system via a user center.

Table 2 provides a comparison of the telecommunication terminal system with existing systems.

Table 2. Comparison With Existing Systems

Services provided	Radio paging	2-way data/ message transmission	Radio telephone	Use of portable terminals
Telecommunication terminal system	Δ	0		0
MCA		Δ	0	
Automobile phone		Δ	0	
Pager	0			

The telecommunication terminal system is chiefly designed for two-way data transmission by radio, whereas the car telephone system is mainly for voice communications. Thus various problems, such as cost and communication speeds, are involved in data communications employing the latter system. The NCA system is primarily for voice communications but can effect data transmission. But because it uses a one-way alternately-talking system, it is difficult to increase the speed of data communications. Radio pagers are only for paging.

### 2.3 Application Fields

The telecommunication terminal system, which is capable of two-way radio data communications, can be used in a wide range of business and work areas, as shown in the illustrations in Figure 2.



Figure 2. Application Fields

Figures 3-10 illustrate specific uses. Applications are expected to have a wide range, including 1) data communications for various forms corporate data retrieval; 2) message exchange as in electronic mail; 3) providing business information utilizing a database; 4) telecontrol for controlling facilities at remote places; and 5) telemetering for gathering information from various sensors.



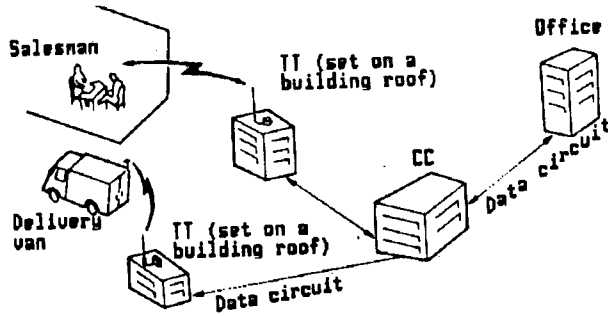

When a salesman receives a product inquiry from a customer, he can obtain immediate answers by inputting inquiry or order data to his office or a center. It is also possible to give delivery instructions to running delivery vans and to carry out production and inventory management.

Figure 3. Application Field for Telecommunication Terminal System

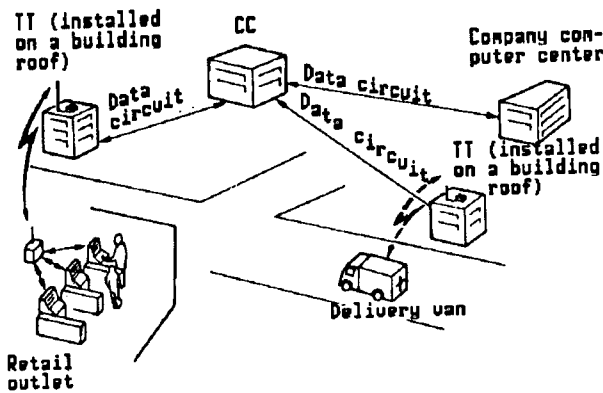

A retailer can transmit data on sales conditions at branch stores minute by minute to the head office computer center. Using these data, it is possible to give delivery instructions to delivery vans and order instructions to the purchasing division.

Figure 4. Application Field for Telecommunication Terminal System

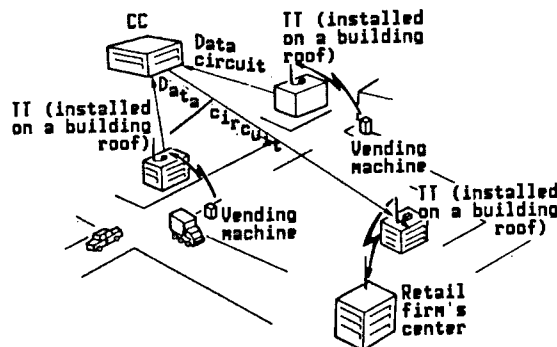

A retail company's center can gather data--such as vending machine, gas station, and frozen food sales, inventory data, and data on equipment conditions--from a number of fixed facilities installed at various places around a city.

Figure 5. Application Field for Telecommunication Terminal System

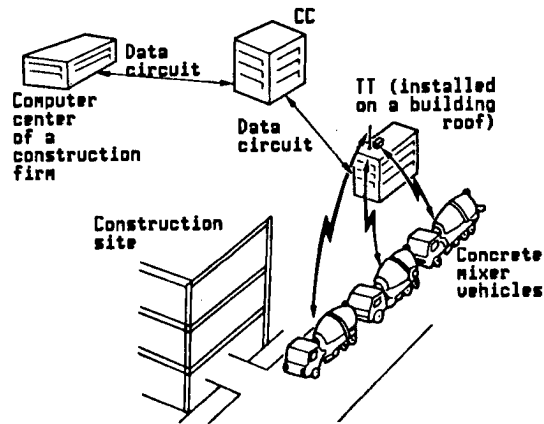

The computer center of a construction company can manage ready-mixed concrete and vehicle allocations, and can issue unloading orders at a construction site using data transmitted from mixer vehicles.

Figure 6. Application Field for Telecommunicationn Terminal System

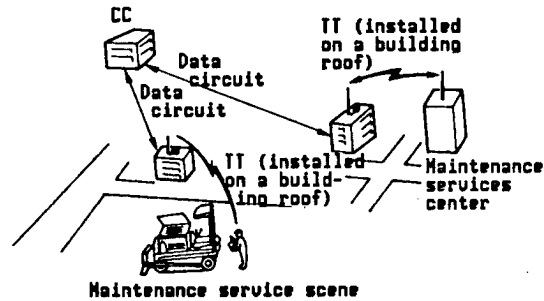

It is possible to ask a maintenance services center for the repair history of a malfunctioning machine by sending the machine's production number to the center and to receive troubleshooting instructions from the center by sending data on the situation, all from the scene.

Figure 7. Application Field for Telecommunicationn Terminal System

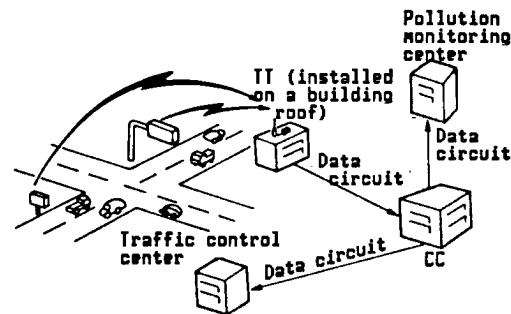

Data obtained from various sensors can be transmitted to the organizations in charge minute by minute.

Figure 8. Application Field for Telecommunicationn Terminal System

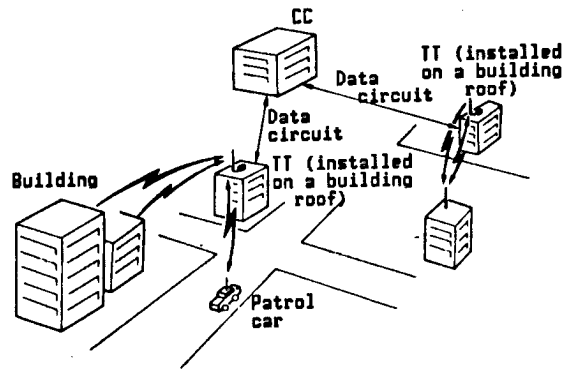

Centralized management of data necessary for building security and management is possible at a security center. It is possible to receive data from the security center while patrolling.

Figure 9. Application Field for Telecommunicationn Terminal System

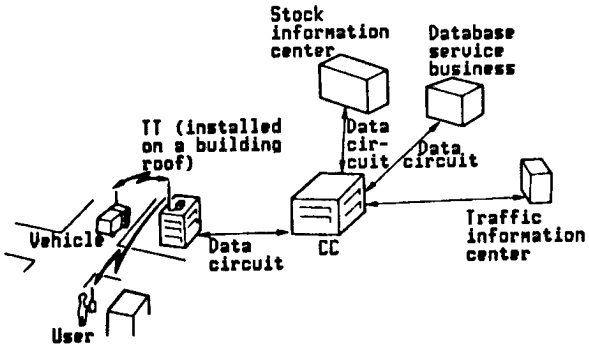

A user can obtain needed information anytime from an information center with which the user has a subscription contract.

Figure 10. Application Field for Telecommunicationn Terminal System

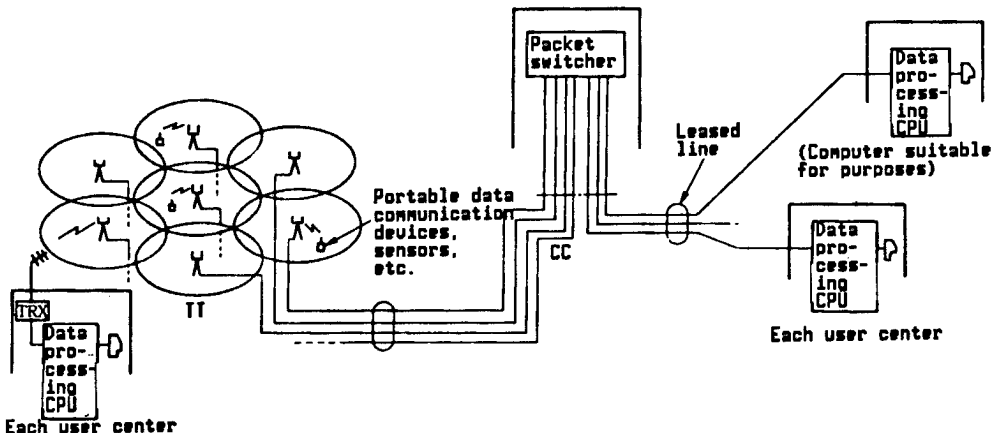

Figure 11. Basic Configuration of System

### 3. Technical Systems of the Telecommunication Terminal System

#### 3.1 Basic System Configuration and Functions

The basic configuration of a telecommunication terminal system comprises, as shown in Figure 11, cooperation center (CC), a telecommunication terminal (TT), a user center (UC), and terminal equipment (TE). Their functions are as follows:

##### (1) TE

The TE is a radio terminal for data communications carried by salesmen and others. It has data input/output functions and communicates with the nearest telecommunication terminal by radio.

##### (2) TT

The TT, installed by a third party, links the TE with the CC. It is a radio station that constitutes a small-zone (about 3 km in radius) radio communications system. Many TTs can be installed within a service area. Having multiple radio channels, the TT's control circuits are handled by the MCA system and they use a packet switching system.

##### (3) CC

Installed by a third party, the CC with the packet switching function links the TTs with the UC.

##### (4) UC

The UC, set up by the users of a telecommunication terminal system, has both data processing and management functions, and connects the users with the CC or TT. There is the UC-Wire, which links the users with the CC by wired communications, and the UC-Radio, which uses radio to communicate with the TTs.

Figure 12 shows the TT and TE.

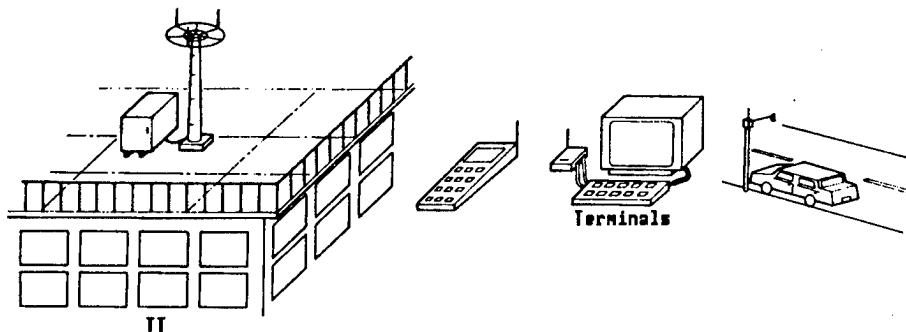

Figure 12. Conceptual Illustrations of Telecommunication Terminal and Terminal Equipment

### 3.2 TT Radio Zoning System

A small-zone configuration, with each zone measuring around 3 km in radius, is said to be suitable for the telecommunication terminal system from the viewpoint of the transmission capacity of portable terminals and TT facility costs. This means that about 40 zones will be required to cover the 23 wards of Tokyo.

### 3.3 System Design Outline

It is necessary to design an optimum telecommunication terminal system by taking into consideration various conditions, such as subscription by many users, the promotion of effective use of facilities through joint use, and compact, lightweight, and economic terminals.

The report compiled by the MPT's Telecommunication Terminal System Study Group can be summarized as follows:

(1) To ensure the efficient use of radio circuits, protect the contents of user communications and handle the necessary amount of information, the telecommunication terminal system should use a circuit control system employing MCA technology and the packet switching system should be used for data transmission. The optimum transmission speed is 4,800 bits per second (BPS) considering the amount of traffic and equipment viability.

(2) The system should be designed by setting the radio circuit bit error rate at  $10^{-3}$  and the actual rate of  $10^{-5}$  should be secured through the use of error correcting codes.

(3) Concrete design specifications are as follows:

Frequency band: 900 MHz (assumed figure)

Modulation system: 4,800 bps, direct frequency shift keying (FSK)

Transmission power--TE: 5 W or less  
TT: 10 W or less

Channel separation: 25 kHz

Number of channels: 200 channels (provisional)

Zone structure: 3 km in radius, repetition of 19 zones

Number of channels per zone--control (C) channel: 1  
signal (S) channel: 9 (maximum)

Access method: slotted alpha system; unused signal channel sent out over C channel

Throughput: maximum 0.4

Packet length: 400 bits

Number of TEs accommodated: 200,000 units/system (supposed figure)

#### 4. Promotion of Commercialization of Telecommunications Terminal System

##### 4.1 R&D of Pilot System by Council for Promotion of Commercialization of Telecommunication Terminal System

The Council for the Promotion of the Commercialization of the telecommunication terminal system was set up on 28 January 1986 by 33 users and makers strongly interested in an early actualization of the telecommunication terminal system. Based on its prospectus, shown in Table 3, since its inception the council has been positively pursuing a number of activities, including feasibility studies on the telecommunication terminal system; R&D on the system; various preparations necessary for the practical implementation of the system; and publicity related to the use of the system.

As part of its activities, the council has developed a pilot telecommunication terminal system. A number of experiments will be performed with this system beginning in July 1987 with completion set for March 1988.

An outline of the pilot system experiments is given below:

##### 1. Objective

The objective of the experiments is to study basic radio wave propagation characteristics and to verify the basic specifications of the system to reflect them for the development of a practical use system.

##### 2. Outline of Experiments

The experiments using the pilot system will be done by installing TTs at three places (Akasuka, Shibara, and Shinjuku) in central Tokyo and using the pilot system's CC (Akasaka), UC (Akasaka), and terminals. Their outline follows the experimental concept shown in Figure 13.

##### (1) Experiment contents and schedule

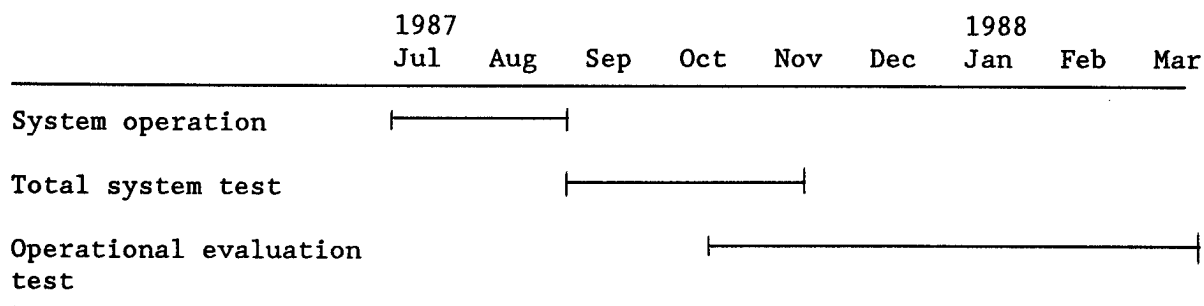

Table 3. Prospectus for Establishment of Council for Promotion of Commercialization of Telecommunication Terminal System

---

In line with progress toward an advanced information society, various systems that gather and process massive amounts of information will be provided in urban areas--where economic and human activities are remarkably brisk--for the improvement of urban functions. At the same time, business demand for various portable data communications equipment is expected to continue to grow.

The Ministry of Posts and Telecommunications worked out the telecommunication terminal system plan to meet such demand and studies have been made on the outline of technical systems and economic viability. It was reported that the system is fully feasible.

As a new medium for land mobile communications, the system is expected drastically to improve the efficiency of socioeconomic activities, contributing much to the development of the Japanese economy.

A number of us who are greatly interested in the realization of this system set up the Council for the Promotion of the Commercialization of the Telecommunication Terminal System in order to contribute to an early development of the system, which we expect will create new business opportunities through the novel use of radiowaves and will improve productivity in corporate management.

The council will engage in the following activities:

- (1) Feasibility studies on the telecommunication terminal system
- (2) R&D on the telecommunication terminal system
- (3) Various preparations necessary for the commercial use of the telecommunication terminal system
- (4) Activities to promote the use of the telecommunication terminal system

The telecommunication terminal system has a wide variety of applications, such as business data communications, automobile information systems, and information management systems within an urban area. We hope to succeed in putting the system to practical service at an early date. The council is playing a central role in developing a system that is easy to use in various areas.

---

Various demonstration programs will be developed for the operational evaluation test to evaluate the effectiveness and ease of the system's operation.

Likely areas of application are shown in Table 4. Members of the council independently developed either terminals or UCs-W for experiments to further verify the systems practicability.

Table 4. Outline of Functions of Demonstration Programs

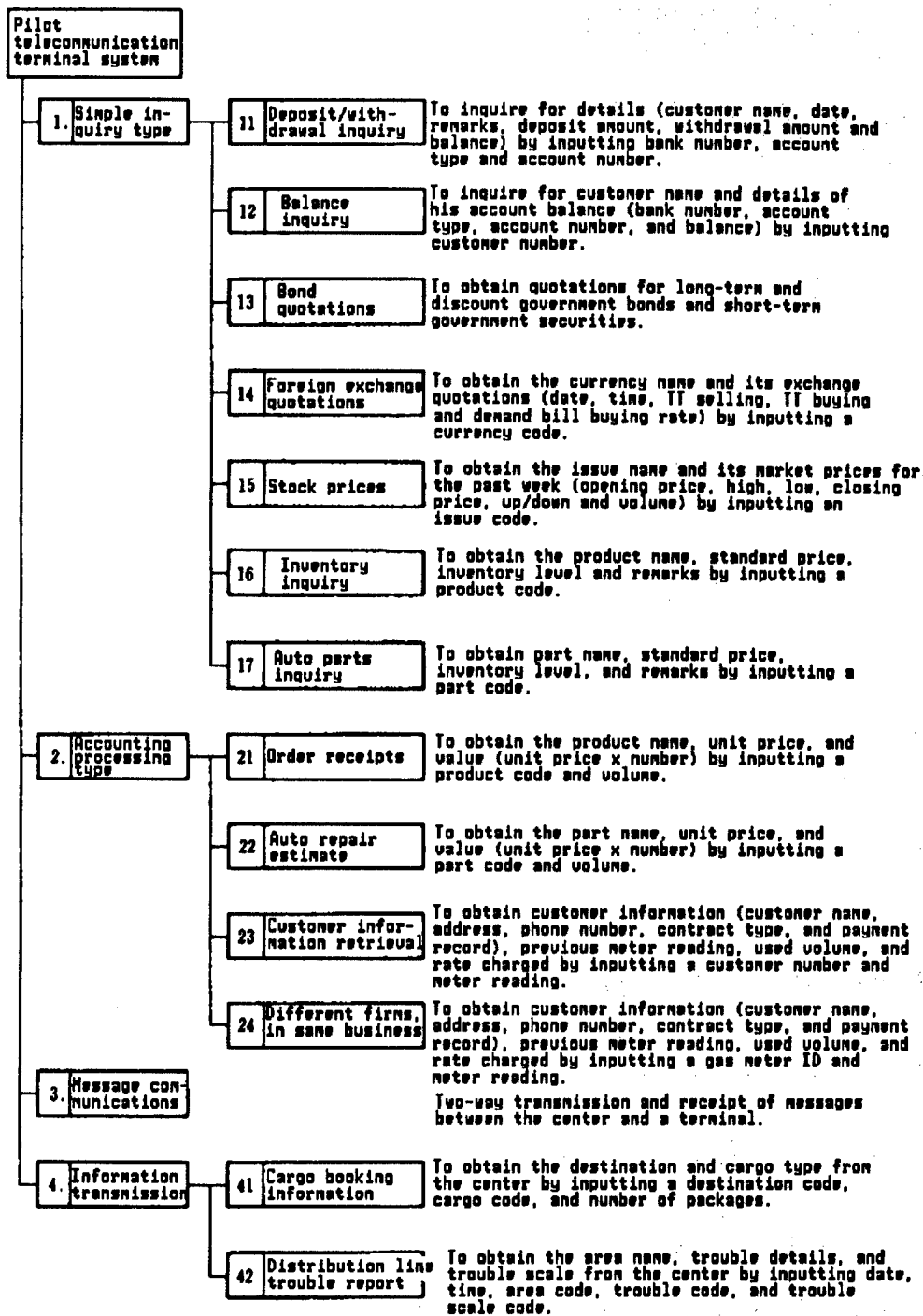



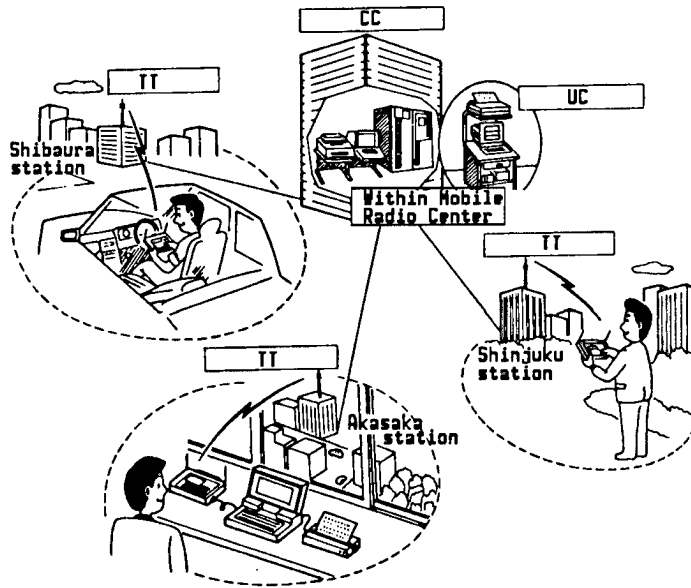

Figure 13. Concept of Pilot Telecommunication Terminal System

## (2) Pilot System Configuration

The configuration of the pilot system is shown in Figure 14. The experiments will be done chiefly at a transmission speed of 4,800 bps. Propagation data will be gathered at a speed of 9,600 bps.

## (3) Outline of Radio Stations

Type	Name	Place	Frequency band used and aerial power
	Akasaka Station	Mobile Radio Center Akasaka, Minato-ku	
	Shibaura Station	Oki Electric Industry Co., Shibara, Minato-ku	
	Shinjuku Station	Naka Branch Systems Center, Tokyo Gas Co., Nishi-shinjuku, Shinjuku-ku	800 MHz, 20 W
Experiment stations	Mobile stations	Permanently placed at: Mobile Radio Center, Experiment places: mainly outdoors around TTs	800 MHz, 5 W

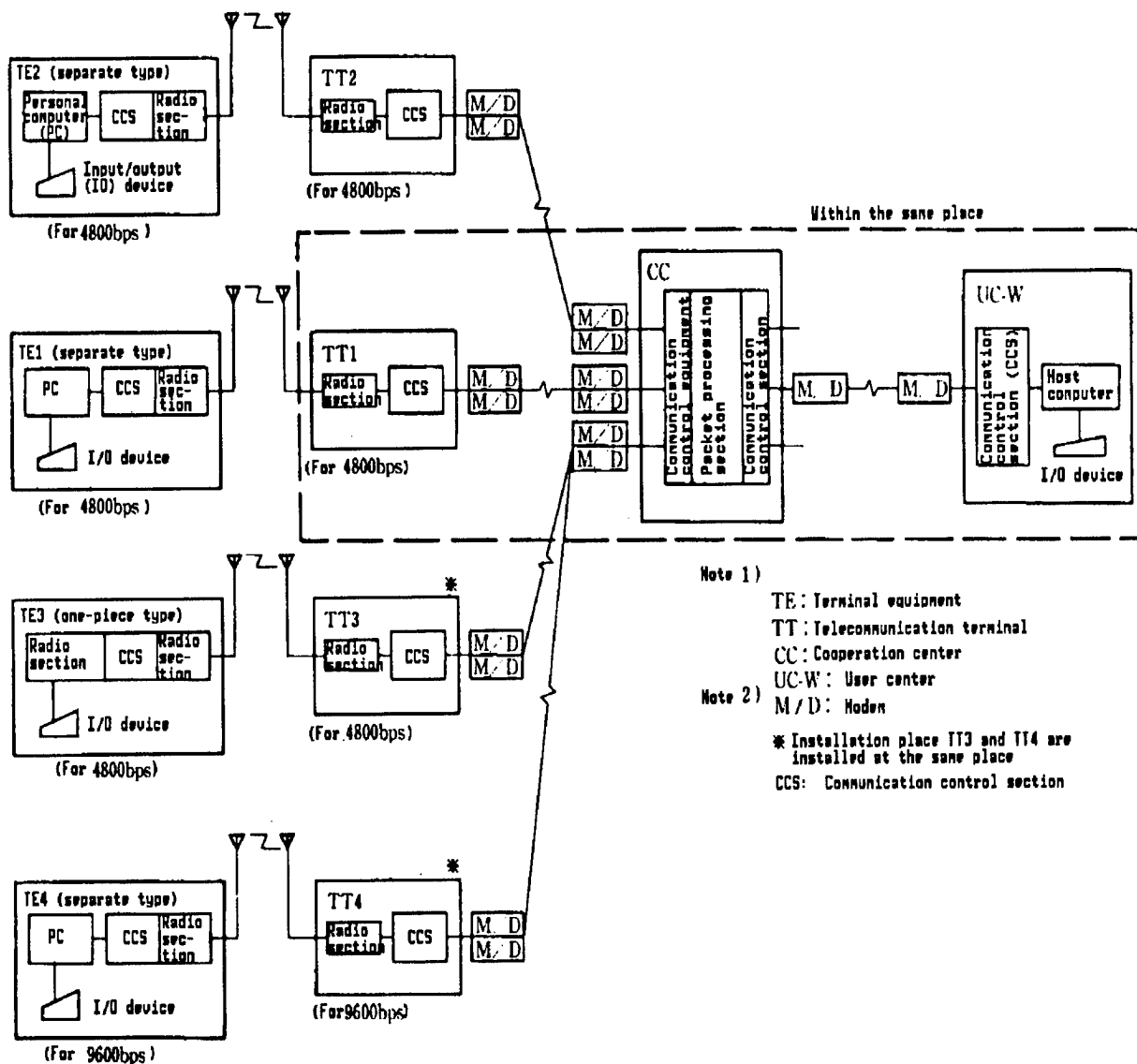

Figure 14. Pilot System Configuration

#### 4.2 Establishment of Company for Feasibility Studies

Based on the fact that the Council for the Promotion of the Commercialization of the Telecommunication Terminal System developed a pilot system as a measure to encourage an early start of practical services and began demonstration experiments to establish specific software, Japan City Media, Inc., was set up 13 July 1987 to conduct feasibility studies for an early start of full-fledged, low-cost and high-quality telecommunications services using the telecommunication terminal system.

The company is projected to become a business company after 1 year of feasibility studies, with the launch of services scheduled for autumn 1989.

An outline of the company follows:

- (1) Corporate name: Japan City Media, Inc.
- (2) Head office: 1-20, 6-chome, Akasaka, Minato-ku, Tokyo  
(Phone: 03-589-4564)
- (3) Capital: paid-up capital ¥400 million (authorized capital ¥1.6 billion)
- (4) Shareholders: Mobile Radio Center  
Tokyo Marine & Fire Insurance Co.  
Tokyo Electric Power Co.  
NEC Corp., and 29 other firms

(5) Structure

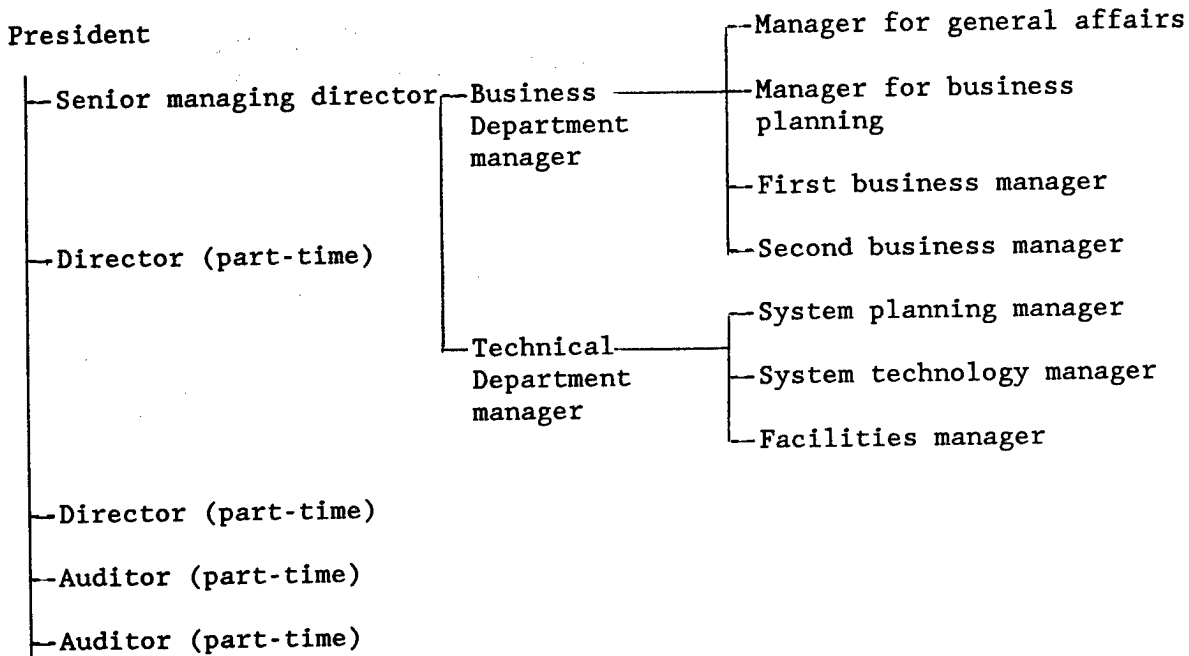

General affairs: General affairs, accounting, public relations

Business planning: Compilation of business plans including business areas and rate system

First business: Development and planning of services, market development and other business activities

Second business: Demand surveys, market development and other business activities

System planning: Circuit network planning, rate system development

System technology: Development of practical use systems, including terminals, TTs, and switching systems

Facilities: Business related to installation of TTs and other stations

### (6) Business Outline

To carry out feasibility studies for the operation of a Type I information telecommunications business under the Telecommunications Business Law, the company will conduct the following activities concerning the provision of telecommunications services in wide areas using the telecommunication terminal system.

- A. Consulting for demand surveys covering wide areas and market development
- B. Working out of business plans (including service areas and the rate system)
- C. R&D on practical use system
- D. Selection of places where the CC and TTs should be located
- E. Other related business

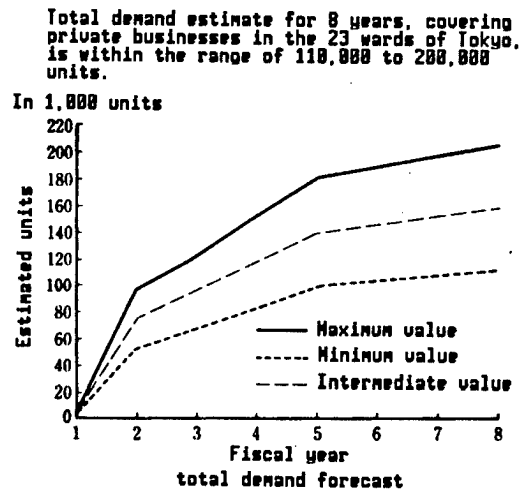

(Reference: Research and survey report on the telecommunication terminal system)

(Compiled by the Study Group on Telecommunication Terminal System, MPT, August 1985)

Figure 15. Demand Forecast

An estimate of demand is an important factor in a management strategy for telecommunication terminal system services, and an outside think tank has been entrusted with surveys on demand trends. According to a report by the MPT's Telecommunication Terminal System Study Group, demand is estimated at 110,000 to 200,000 units within the 23 wards of Tokyo, as shown in Figure 15.

## 5. Conclusion

The telecommunication terminal system is a new medium for mobile communication services providing means of communications that can be used by anyone, anytime, and anywhere. It is expected to play an infrastructural role, coping with demand for mobile communications for various purposes. This demand will arise mainly in urban areas in the future.

For starting commercial services using the telecommunication terminal system, it is necessary to develop a practical-use system by taking into account the deliberations on technical standards by the MPT's Telecommunications Technical Council and the results of the experiments and evaluation on the pilot system conducted by the Council for the Promotion of the Commercialization of the Telecommunication Terminal System. In developing the system, every possible measure must be taken to ensure system expendability, quick response, reliability, and safety.

There are also various other important issues, such as detailed demand trend surveys, market development and the acquisition of places where TTs are to be set up. When commercial services begin, we will provide a system that makes necessary information available accurately and on a real-time basis anywhere and anytime, thereby contributing to the further development of telecommunications services.

20159/9365

**Development of Hand-Free Mobile Phone Reported**

43066548 Tokyo JIDOSHA GIJUTSU in Japanese Feb 88 pp 175-180

[Article by Nobuyuki Ishihara and Takuo Yamamoto, Electronic Technology Department of Toyota Motor Corporation: "Hand-Free Mobile Phone"]

[Text] 1. **Foreword**

The development of an 800 MHz band mobile phone system in Japan has been pursued by the Nippon Telegraph and Telephone Public Corporation since it was started in 1967. This service began in Tokyo in December 1979 after obtaining approval from the Ministry of Posts and Telecommunications in 1976.

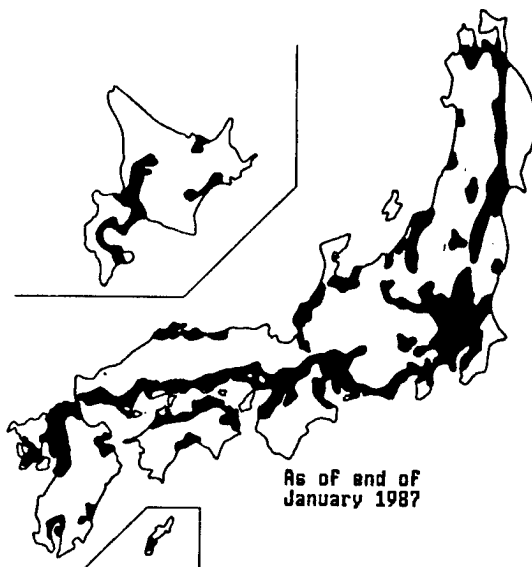

Figure 1. Mobile Phone Service Areas

Telephone service is currently available in the areas shown in Figure 1, which cover about 90 percent of the population of Japan. The basic monthly charge was ¥30,000 when the service started, but this was reduced to ¥20,000 in July 1985. The number of subscribers has increased dramatically and as of March 1987 the number of mobile phones was 100,000 (Figure 2).

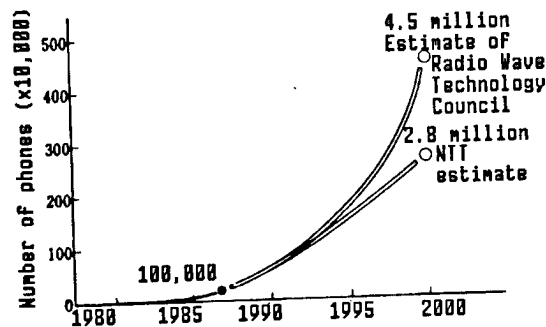

Figure 2. Growth of Mobile Phones

In recent years, the telecommunications administration has also changed greatly. The telecommunications business was privatized as of 1 April 1985, and at the same time it became possible for private corporations to freely manufacture and sell telephone terminal equipment if they could satisfy "the technical condition of the connection of mobile phone terminals, etc." set by Nippon Telegraph and Telephone Corporation (TNT) and if their equipment is approved by the Telecommunications Terminal Equipment Inspection Association.

In response to these changes, a number of companies have developed telephone terminal equipment that is easy to use and is harmonious with the interior of a room, and have started selling them. This report will discuss the hand-free mobile phone announced by Toyota in September 1987 and that is currently being mounted in the new model Crown.

## 2. System Composition

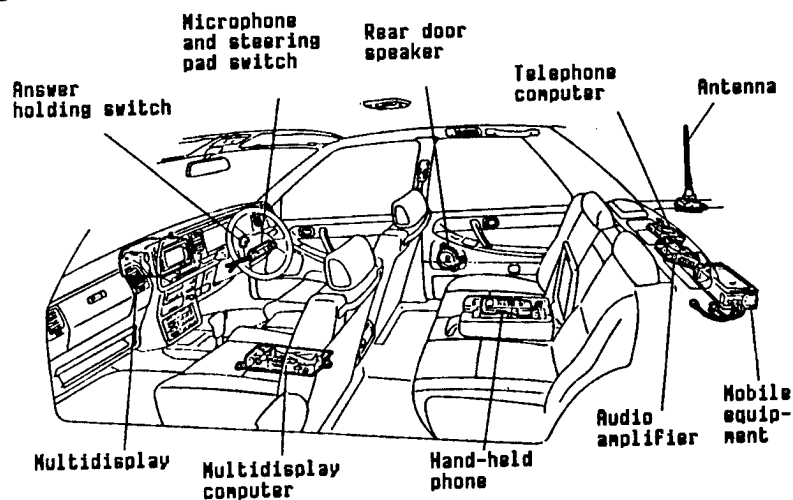

Figure 3. System Composition (car equipped with multivision)

With regard to the composition of the telephone mounted in the new model Crown, Figure 3 shows a car equipped with multivision while Figure 4 shows

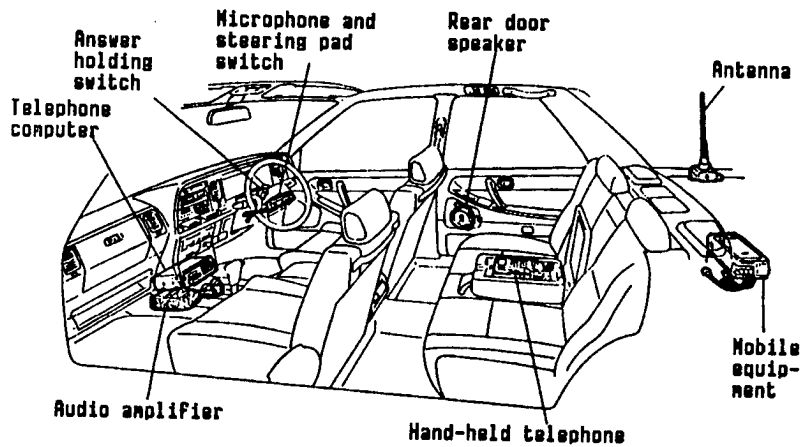

Figure 4. System Composition (Car not equipped with multivision)

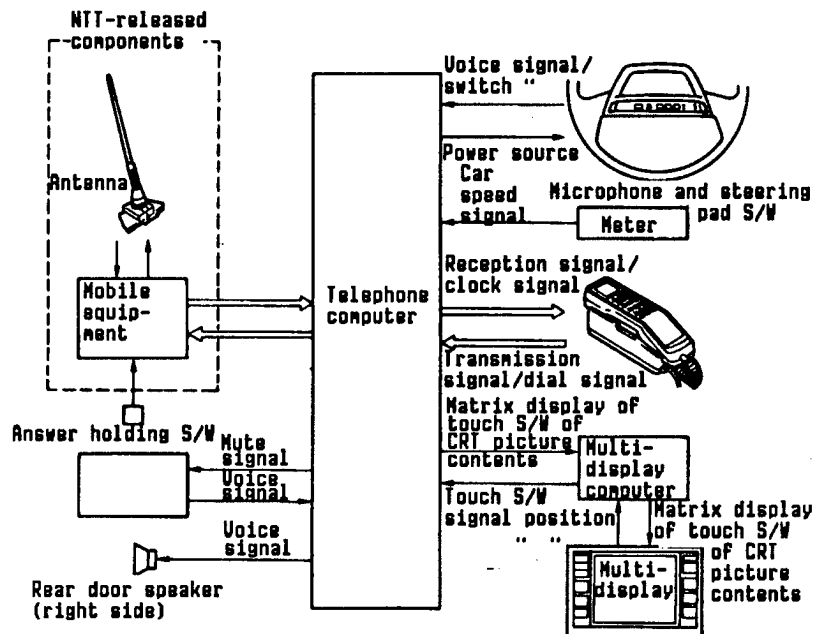

Figure 5. System Block

a car not equipped with multivision. Figure 5 is a block diagram of all the elements of a car equipped with the multivision system.

### 3. Function

A comparison of the functions of Toyota's mobile phone system with those of other companies is shown in Table 1.

#### 3.1 Telephone Computer

This is the body of the hand-free phone. Its functions include those of a telephone terminal (hook control, dial control, and the interface with the



Table 1. Comparison of the Functions of the Mobile Phones of Different Companies

Item	New Crown	Nissan Cedric 1)	Mitsubishi Debonair 2)	NTT CAT100	
Composition	Possible to have extension phone by installing hand-free and hand-held phones independently	Maker option to install hand-free or hand-held phones	Maker option to install hand-free phone used in combination with NTT's hand-held phone	Sold through mobile phone service company	
Hand-free	Transmission microphone	Built-in in steering pad	Built-in in right side of meter cluster	Built-in in right front pillar	
	Reception speaker	Use the one for audio equipment	Set in console section	Set in console section	
	Steering pad switch	Shortened transmission	<input type="radio"/> 3, number of memory units is 10	<input type="radio"/> 10	<input type="radio"/> 10
		Transmission	<input type="radio"/>	<input type="radio"/>	<input type="radio"/>
		Reception	<input type="radio"/> One switch	<input type="radio"/>	<input type="radio"/>
	Ring off	<input type="radio"/>	<input type="radio"/>	<input type="radio"/>	
	Reception volume control	<input type="radio"/> Controller, CRT	<input type="radio"/> Steering pad or handset	<input type="radio"/> Volume of speaker section	
	Dial transmission	<input type="radio"/> Possible only when stopped	x	x	
	Memory number display	<input type="radio"/>	x	<input type="radio"/> Indicator in meter	
	Dial number display	<input type="radio"/>	<input type="radio"/> Display on handset	<input type="radio"/> Talkback by Speech synthesis	
	Audio mute	<input type="radio"/>	x	<input type="radio"/>	
	Handset	Dial number display	<input type="radio"/> 10 digits	<input type="radio"/> 16 digits	<input type="radio"/> 10 digits
		Transmission mute	x	<input type="radio"/>	x
Speaker reception		<input type="radio"/>	<input type="radio"/>	<input type="radio"/>	
Transmission not picking up handset		<input type="radio"/>	<input type="radio"/>	<input type="radio"/> Use NTT's	
Redial		<input type="radio"/>	<input type="radio"/>	<input type="radio"/>	
Shortened transmission about next number while using phone		<input type="radio"/> 10	<input type="radio"/> 10	<input type="radio"/> 20	

Note 1: See handbook for new model Nissan Cedric  
 2: See handbook for new model Mitsubishi Debonair

mobile equipment such as transceivers), relay between the hand-held phone and the mobile equipment, communication with the multivision, the howling canceler, etc., which controls the mobile phone system. It also has other functions such as transmission control to secure driving safety by prohibiting transmission other than the one-touch curtailed transmission while the car is running, and automatically muting the sound of the car's audio equipment while the phone is in use. This applies to both the hand-free and hand-held phones.

The hand-free phone is manipulated by the manipulation panel shown in Figure 6 in the car not equipped with the multivision.

### 3.2 Microphone and Steering Pad Switch

This serves to convert the transmitted and received voices of the hand-free phone into electric signals. Other functions include conversion of the signals, conversion of the signals of the steering pad switch into DTMF signals, and frequency modulation of these signals.

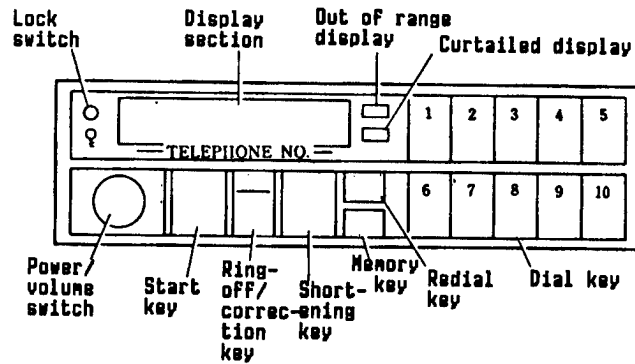

Figure 6. Hand-Free Phone Manipulation Panel of Car Not Equipped With Multivision

### 3.3 Hand-Held Phone

Figure 7 shows a telephone that incorporates the function of a telephone terminal.

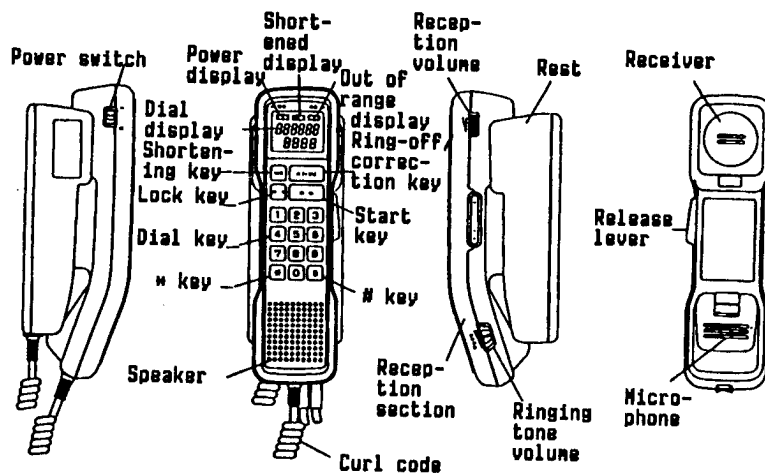

Figure 7. Hand-Held Telephone

### 3.4 Multidisplay Computer

In the car equipped with multivision, the hand-free phone is controlled by the tube-face switch on the multidisplay.

## 4. Subjects for Examination and Countermeasures

The following points should be taken into account in the development of mobile phone terminals: 1) Ease of mounting, use, and operation; 2) interface with NTT mobile equipment; 3) noise interference; and 4) guarantee of speech reproduction quality, etc. The following section examines the phone system installed in the Crown model on the basis of these points.

#### 4.1 Ease of Mounting, Use, and Operation

The question of mounting the equipment is the first problem that must be addressed in designing a mobile phone. Even after it was made small in 1980, the electronic equipment package for a mobile phone has a volume of 1.5 L and weighs 2.4 kg. To avoid any reduction of luggage space and to enhance its outward appearance, the mounting site was changed from the luggage floor to the upper back and its outward appearance was improved with a cover. The strength of the new place where the mobile equipment was to be fixed was confirmed by conducting endurance tests on bad roads, etc. In the case of a sedan, the antenna of the mobile phone is generally fixed to the trunk lid, but in the case of the new Crown model, it was feared that the antenna base and the fender would interfere with each other because the gap of the trunk lid was narrowed to produce a better outward appearance. Toyota then asked Japan Mobile Phone Service (JMPS) to develop a thinner antenna base, and this made it possible to fix the antenna to the lid.

The microphone is built into the steering column pad so that the transmitting voice would not be affected by having the hand or the steering wheel moving in front of the microphone.

This arrangement makes it possible for the speaker to talk naturally into the microphone in front of him. The most frequently used hook switch was placed with the shortened transmission switch so that transmission can be achieved through a single manipulation.

The speakers for the audio equipment are also used for the phone. This is done to save on space and weight, to ensure the quality of the sound, and to lower costs.

#### 4.2 Disturbance by Noise

In the Toyota mobile phone system, digital communication takes place between the telephone computer and the multidisplay computer, while analog communication takes place between the telephone computer, the microphone, and the steering pad switch. Therefore, any noise disturbance would be a fatal defect.

As shown in Table 2, the digital communication link is ensured by including a photocoupler, that is highly resistant to car noise. The analog link, meanwhile, uses an FM signal on the 60 MHz band carrier that is largely unaffected by outside electromagnetic obstruction evading the noise of the slip ring. Various noise tests have been conducted to confirm that there are no noise-related problems.

It is also necessary to consider the possibility that the radio waves emitted from the car could affect others. To protect against this, the phone uses only a feeble radiowave (under 500  $\mu$ V at a point of 3 m from the car). This, however, is enough radio-wave strength to ensure a sufficient S/N ratio.

Table 2. Communication Method Between Telephone Computer and Multidisplay Computer

Synchronizing method	Start/stop synchronizing method
Transfer speed	4,800 bps + 1.0 percent
Code method	NRZ
Logic	Positive logic (however, LED on is '1')
Error detection method	Vertical parity: even 1 bit Horizontal parity: even 1 byte
Bit delivery order	Deliver from LSB
Start bit	'0' 1 bit
Stop bit	'1' bit
Data	8 bit
Mark condition	'1' (= LED off)

### 4.3 Guarantee of Speech Quality

Volume, clarity, and naturalness are the criteria used to evaluate speech quality. A comfortable volume for communication must be secured without noise while producing a natural tone. The following section describes how these criteria were met during the process of the development of the hand-free phone system.

#### (1) Selection of Receiving Speaker

The biggest problems in the development of a hand-free phone system are howling and echo back. Volume and sound quality must be secured while at the same time howling and echo back must be suppressed. Howling is defined as "an oscillating state produced by electric or acoustic combination." If the reflection from the communication circuit equipment--such as mobile equipment, switchboards, and communication lines--or if the acoustic combination of the speaker and the microphone is large, the positive feedback gain of a closed loop consisting of the microphone→microphone amplifier→communications circuit equipment→speaker amplifier→microphone exceeds 1 (when  $G_m + G_a + G_s + G_l > 1$  in Figure 10) then oscillating state is created and peep sound is produced. Echo back occurs when the gain of the sounds net from the microphone is reflected a little late at the communication circuit equipment in a similar closed loop, and the result is like talking in a tunnel. The speaker and the microphone in a hand-free mobile phone system must be arranged in close proximity, and so the acoustic combination of the speaker and microphone is likely to become large. Therefore, the arrangement of the speaker and the microphone is an

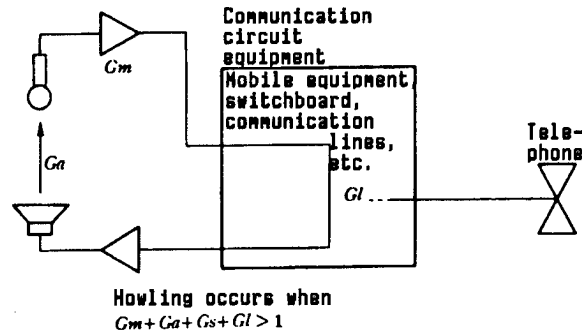

Figure 10. Occurrence of Howling

important point in the development of a hand-free phone system. Toyota's hand-free phone system, as stated above, has been developed with the microphone built into the steering wheel pad and it uses the speakers for the car's audio system.

In the new model Crown, a total of six speakers are used for the audio system. One speaker is installed in each of the four doors and two woofers are located in the package tray. For each of the four door speakers (but not the two woofers) the sound pressure ( $P_e$ ) at the ear position of the driver's seat and the acoustic combination ( $P_m$ ) of the speaker and microphone, respectively were measured, and a comparative study of the  $P_e/P_m$  ratio was conducted to determine which offered the best characteristics. The tests revealed that the quality of the sound could be ranked in the following order: rear left rear right > front left > front right (Figure 11). Based on this result, it was decided to use the right rear door speaker for the telephone so that a sufficient receiving volume could be ensured for the rear seat.

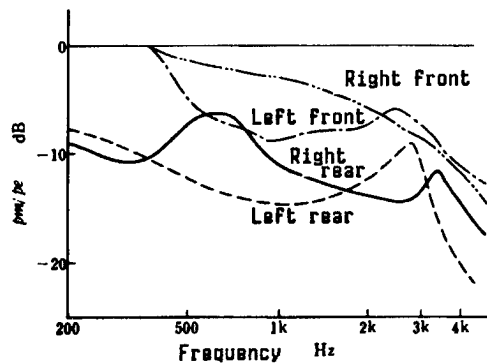

Figure 11. Anti-Howling Performance of Audio Speakers

## (2) Examination of Howling Canceler

As stated above, the purpose of a howling canceler is to ensure that loop gain does not exceed 1 while maintaining adequate transmission and reception volumes. Otherwise, if the amplifier gain of transmission/reception is raised to secure transmission/reception volumes,

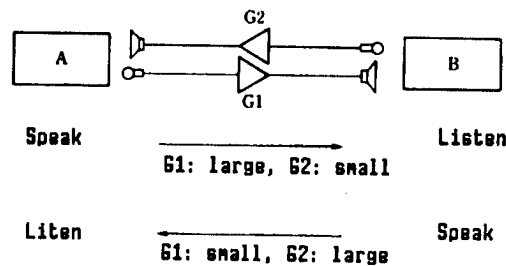

Figure 12. Action of Howling Canceler

the loop gain in the system will exceed 1 and howling will occur. As shown in Figure 12, the principle is that the amplifier gain of A→B is made high and that of B→A low, because B is listening when A is speaking, and the pattern is reversed when B is speaking and A is listening.

Howling cancelers can use a number of methods, including:

1. Reception priority/transmission interruption control;
2. Transmission priority/reception interruption control; and
3. Transmission/reception comparison control.

The digital switching version of the transmission/reception comparison control method was adopted for cars equipped with multivision while the analog switching version of the transmission priority/reception interruption control method was adopted for cars not equipped with multivision. The following will examine the control amount of the howling canceler used for the hand-free phone, which adopted the digital switching method of transmission/reception comparison control, installed in the car equipped with multivision. Howling will be prevented if the amount of control is large, but the swinging of sound will also become large at the same time, and speech quality will be lowered. To overcome this problem, the relation between the amount of control exercised by the howling canceler and sound swinging was evaluated directly by sense. As a result, it was determined that a controlling amount of 6 dB is good for one-way communication--receiving only like a telephone service--while a controlling amount of 12 dB is good for two-way communication--like an ordinary conversation--as shown in Figure 13. Thus, while it would be desirable to have a controlling amount of 6 dB, the amount was set at 12 dB. This is because the circuit gain of the mobile phone is uncertain, the volume of telephone conversations should be made as large as possible, and the mobile phone is used mostly for mutual communication.

### (3) Noise Control

Noise entering a mobile phone conversation can generally be divided into two categories. The first is radio noise, such as fading or multipass,

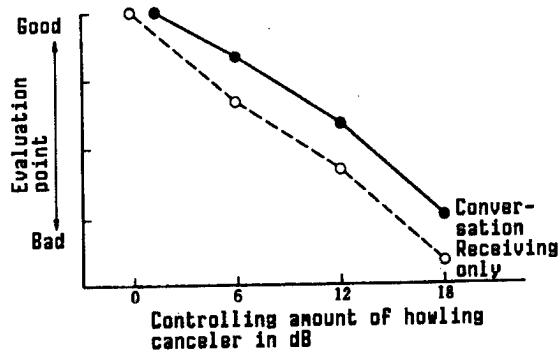

Figure 13. Relation Between Controlling Amount of Howling Canceler and Sound Swinging

caused by changes in the electric field while the car is running. The other is noise generated from the onboard electrical equipment. Since the former cannot be controlled even by a first-class telecommunication industry, examinations were conducted on the latter. A test car was brought to a place where the radio waves of the mobile phone have only a feeble electric field strength and the noise entering the transmission and reception was evaluated directly by sense when the respective pieces of onboard electrical equipment were put into operation. As a result, it was confirmed that no piece of onboard electrical equipment has problems.

## 5. Conclusion

It is planned that in the future the mobile phone will use narrow bands and small zones to cope with the saturation of the circuit by the expected increase in the number of subscribers. Another urgent need is to develop merchandise to meet the needs of users. This could include further reductions in the size of mobile equipment, devising nonprojecting antennas, the participation of NCC, and the installation of new media devices such as facsimile machines and videotext equipment. We would feel greatly rewarded if this report should prove helpful in the development of such products.

In conclusion, we would like to express our sincere appreciation to the persons concerned from JMPS, Matsushita Communication Industrial Co., Nippon Denso Co., and Fujitsu Ten Co. for their cooperation in the development of this system.

20155/9365

END

10

This is a U.S. Government publication. Its contents in no way represent the policies, views, or attitudes of the U.S. Government. Users of this publication may cite FBIS or JPRS provided they do so in a manner clearly identifying them as the secondary source.

Foreign Broadcast Information Service (FBIS) and Joint Publications Research Service (JPRS) publications contain political, economic, military, and sociological news, commentary, and other information, as well as scientific and technical data and reports. All information has been obtained from foreign radio and television broadcasts, news agency transmissions, newspapers, books, and periodicals. Items generally are processed from the first or best available source; it should not be inferred that they have been disseminated only in the medium, in the language, or to the area indicated. Items from foreign language sources are translated. Those from English-language sources are transcribed, with the original phrasing and other characteristics retained.

Headlines, editorial reports, and material enclosed in brackets [ ] are supplied by FBIS/JPRS. Processing indicators such as [Text] or [Excerpts] in the first line of each item indicate how the information was processed from the original. Unfamiliar names which are rendered phonetically or transliterated by FBIS/JPRS are enclosed in parentheses. Words or names preceded by a question mark and enclosed in parentheses were not clear from the original source but have been supplied as appropriate to the context. Other unattributed parenthetical notes within the body of an item originate with the source. Times within items are as given by the source.

### SUBSCRIPTION/PROCUREMENT INFORMATION

The FBIS DAILY REPORT contains current news and information and is published Monday through Friday in 8 volumes: China, East Europe, Soviet Union, East Asia, Near East & South Asia, Africa (Sub-Sahara), Latin America, and West Europe. Supplements to the DAILY REPORTs may also be available periodically and will be distributed to regular DAILY REPORT subscribers. JPRS publications generally contain less time-sensitive information and are published periodically. Current JPRS publications are listed in *Government Reports Announcements* issued semi-monthly by the National Technical Information Service (NTIS), 5285 Port Royal Road, Springfield, Virginia 22161 and the *Monthly Catalog of U.S. Government Publications* issued by the Superintendent of Documents, U.S. Government Printing Office, Washington, D.C. 20402.

U.S. Government offices may obtain subscriptions to the DAILY REPORTs or JPRS publications (hardcovers or microfiche) at no charge through their sponsoring organizations. DOD consumers are required to submit requests through appropriate

command validation channels to DIA, RTS-2C, Washington, D.C. 20301. (Telephone: (202) 373-3771, Autovon: 243-3771.) For additional information or assistance, call FBIS, (703) 527-2368, or write to P.O. Box 2604, Washington, D.C. 20013.

The public may subscribe to either hardcover or microfiche versions of the DAILY REPORTs and JPRS publications through NTIS at the above address or by calling (703) 487-4630. Subscription rates will be provided by NTIS upon request. Subscriptions are available outside the United States from NTIS or appointed foreign dealers. Back issues or single copies of the DAILY REPORTs and JPRS publications are not available. New subscribers should expect a 30-day delay in receipt of the first issue.

Both the DAILY REPORTs and the JPRS publications are on file for public reference at the Library of Congress and at many Federal Depository Libraries. Reference copies may also be seen at many public and university libraries throughout the United States.