

286138

JPRS 84122

15 August 1983

DISTRIBUTION STATEMENT A
Approved for public release;
Distribution Unlimited

East Europe Report

POLITICAL, SOCIOLOGICAL AND MILITARY AFFAIRS

No. 2185

19980608 195

DUPLICATE SUPPLIED

FBIS

FOREIGN BROADCAST INFORMATION SERVICE

7
76
A05

NOTE

JPRS publications contain information primarily from foreign newspapers, periodicals and books, but also from news agency transmissions and broadcasts. Materials from foreign-language sources are translated; those from English-language sources are transcribed or reprinted, with the original phrasing and other characteristics retained.

Headlines, editorial reports, and material enclosed in brackets [] are supplied by JPRS. Processing indicators such as [Text] or [Excerpt] in the first line of each item, or following the last line of a brief, indicate how the original information was processed. Where no processing indicator is given, the information was summarized or extracted.

Unfamiliar names rendered phonetically or transliterated are enclosed in parentheses. Words or names preceded by a question mark and enclosed in parentheses were not clear in the original but have been supplied as appropriate in context. Other unattributed parenthetical notes within the body of an item originate with the source. Times within items are as given by source.

The contents of this publication in no way represent the policies, views or attitudes of the U.S. Government.

PROCUREMENT OF PUBLICATIONS

JPRS publications may be ordered from the National Technical Information Service, Springfield, Virginia 22161. In ordering, it is recommended that the JPRS number, title, date and author, if applicable, of publication be cited.

Current JPRS publications are announced in Government Reports Announcements issued semi-monthly by the National Technical Information Service, and are listed in the Monthly Catalog of U.S. Government Publications issued by the Superintendent of Documents, U.S. Government Printing Office, Washington, D.C. 20402.

Correspondence pertaining to matters other than procurement may be addressed to Joint Publications Research Service, 1000 North Glebe Road, Arlington, Virginia 22201.

15 August 1983

EAST EUROPE REPORT
POLITICAL, SOCIOLOGICAL AND MILITARY AFFAIRS

No. 2185

CONTENTS

INTERNATIONAL AFFAIRS

Briefs

| | |
|----------------------------------|---|
| Bloc Journalists Meet | 1 |
| Czechoslovak-Hungarian Book Fair | 1 |

BULGARIA

| | |
|--|----|
| Atanasov Speaks on Marxist Theory, CPSU Role (BTA, 28 Jul 83)..... | 2 |
| Leaders Attend Ilinden Insurrection Anniversary (BTA, 31 Jul 83)..... | 4 |
| Ilinden Insurrection Anniversary Marked by Press (Kostadin Kyulyumov Interview; ZEMEDEL'SKO, 31 Jul 83).... | 6 |
| Bulgarian Nature of Macedonia Stressed (Khristo Khristov; RABOTNICHESKO DELO, 25 Jul 83)..... | 7 |
| Scholar Dwells on Uprising in Macedonia in 1903 (SOFIA NEWS, 13 Jul 83)..... | 9 |
| Briefs | |
| Foreign Communications Visitor Welcomed | 12 |
| Sao Tome, Principe President Visits | 12 |
| Bulgarian-Japanese Economic Cooperation | 12 |
| Cooperation With Austria | 13 |
| French Embassy Reception | 13 |
| Envoys Mark Bolivar Anniversary | 13 |
| Japanese Foreign Minister To Visit | 14 |
| USSR Rail Link Protocol | 14 |
| Kubadinski Reviews Forthcoming Elections | 14 |

CZECHOSLOVAKIA

Further on Release of Imprisoned Franciscans
(Vatican City Radio, 28 Jul 83)..... 15

GERMAN DEMOCRATIC REPUBLIC

Pacifist Appeals to Honecker, UN Secretary, FRG Parties
Reported
(FRANKFURTER RUNDSCHAU, 14 Jun 83)..... 16

'Letter to Honecker' Controversy, by Karl-Heinz Baum
Letter to UN Secretary, by Karl-Heinz Baum
Letter to Bundestag Parties

Regime Seen Beginning To Acknowledge Church-Led Peace
Movement
(Peter Jochen Winters; FRANKFURTER ALLGEMEINE,
5 Jul 83)..... 19

Ideopolitical Diversity of 'Friendship Groups' Seen in
Positive Light
(NEUES DEUTSCHLAND, 8 Jul 83)..... 22

Basic Motorized Rifle Troop Vehicle Described
(Ulrich Fink; AR-ARMEERUNDSCHAU, No 7, Jul 83)..... 25

Military Innovators Cited in Conservation Efforts
(Manfred Gehmert; PRESSE INFORMATION, No 78, 7 Jul 83)..... 28

HUNGARY

Church Urges Religious Education for Children
(Maria Galantai; UJ EMBER, 12 Jun 83)..... 30

Szaraz Discusses Development of Historical Awareness
(Gyorgy Szaraz Interview; NEPHADSEREG, 19 Mar 83)..... 32

Review Finds Book Historically Myopic, 'Self-Mutilating'
(Gabor Szigethy; MOZGO VILAZ, No 6, 1983)..... 36

Briefs
Vatican Visit 40

POLAND

Army Daily Comments on Walesa's Remarks, Wealth
(ZOLNIERZ WOLNOSCI, 27 Jun 83)..... 41

| | |
|--|----|
| Official Interviewed on Transfer of Union Assets (Romana Kalecka Interview; ZYCIE WARSZAWY, 27 Jun 83)..... | 43 |
| Return to Scientific Marxism-Leninism Urged (Wlodzimierz Lebedzinski; NOWE DROGI, No 4, Apr 83)..... | 45 |
| Provincial Trade Union Developments Reported (Various sources, 25, 26, 30 May 83)..... | 57 |
| Six-Months Trade Union Activities, by Andrzej Sitek | |
| Development of Supraplant Unions | |
| Enriching Forms, Programs of Union Activities | |
| Development of Supraplant Trade Unions | |
| Trade Unions After 5 Months, by Zbigniew Jurkiewicz | |
| ROMANIA | |
| Membership, Tasks of New National Command for Agriculture (SCINTEIA, 10 Jul 83)..... | 67 |
| YUGOSLAVIA | |
| Blagoje Taleski Notes Problems With Neighboring States (TANJUG, 28 Jul 83)..... | 70 |

BRIEFS

BLOC JOURNALISTS MEET--Tuesday began an international conference of domestic affairs correspondents at Hotel Interpress in Balatonszeplak, with participants from Bulgaria, Czechoslovakia, Poland, GDR, Romania, and the Soviet Union, as well as our own journalists. The conference centers on press and media methods for promoting public order and traffic safety. [Text]
[Budapest MAGYAR NEMZET in Hungarian 8 Jun 83 p 3] 9890

CZECHOSLOVAK-HUNGARIAN BOOK FAIR--An extensive book fair opened Tuesday in Bratislava, honoring 30 years of Hungarian-Czechoslovak joint publishing. The nearly 1,500 volumes at the fair provide a cross-section of Hungarian works published in cooperation with Czechoslovakia as well as a picture of the value of Hungarian books in the last few years. Laszlo Udvarhelyi, director of the Scientific Secretariat, awarded high Hungarian citations to outstanding Slovakian publishers Monday at the Bratislava Hungarian consulate, in honor of their contributions to this growing cultural exchange. According to UNESCO statistics, of all Czech and Slovak works translated, most have been into Hungarian. This shining example of literary exchange serves to unite the people of the two countries and also has a leading role in the education of Czechoslovakians of Hungarian origin. [Text] [Budapest MAGYAR NEMZET in Hungarian 8 Jun 83 p 4] 9890

CSO: 2500/324

ATANASOV SPEAKS ON MARXIST THEORY, CPSU ROLE

AU282010 Sofia BTA in English 1830 GMT 28 Jul 83

["The Bolshevik Party--A Party of New Type"--BTA headline]

[Text] Sofia, 28 Jul (BTA)--The 80th anniversary of the Second Congress of the Russian Social Democratic Workers' Party (RSDWP) was solemnly marked here today. In the presence of Mr Todor Zhivkov, secretary general of the CC of the BCP and president of the State Council and other party and state leaders, a paper was read out at the meeting by the BCP CC Secretary Georgi Atanasov, vice president of the State Council and chairman of the Committee for State and People's Control.

Mr Georgi Atanasov pointed out that the ideas and principles which triumphed in the RSDWP at its second congress, are today ideas and principles of the CPSU, ideas and principles of the countries of real socialism, of the world communist movement. Eighty years ago, in a heavy struggle with the opponents of revolutionary Marxism, the Bolshevik party was founded--a party of new Marxist-Leninist type, a combat vanguard in thought and revolutionary action, the speaker emphasized.

Dwelling on the historical gains of the CPSU throughout the years, he pointed out that today it is a model of revolutionism, foresight and creative onset, of the skill of soberly analyzing the problems, of bravely overcoming the hardships, of fulfilling its patriotic and international duty with honour.

The people's democratic revolutions in a number of countries of the world, including Bulgaria, which made many an original contribution to the Marxist-Leninist theory and practice, were a repetition of the October Revolution in its core, a realization of the general lawful regularities which manifested themselves for the first time in the practice of the Russian workers and peasants, Mr Georgi Atanasov stressed. He said: "As the historical experience has shown, but the repudiation from the profound mastering of the creative approach to Leninism ensured the victory of the socialist revolution of these countries."

The efforts made to reject the international nature of Leninism, to oppose it to Marx, to regard it as "a pure Russian event" are nothing but an attempt to deprive the revolutionary theory of the proletariat of its class content,

to deprive the working class of a correct strategy and tactics in the revolutionary struggle, the speaker continued. Now, at a time, when more than ever before the communists bear responsibility for the fate of mankind, life requires unity and cohesion in the communists' acts. The proletarian internationalism is a key problem of the contemporary world revolutionary process.

Mr Atanasov dwelt also on the question related to democracy under socialism. He said that the socialist revolution is the most reliable road to converting the immediate and future requirements of the working people into solid democratic gains. The efforts made to draw the class content of democracy and to estimate and qualify the political system of socialism from the positions of the bourgeois practice is a manifestation of subversion and lack of understanding.

Mr Georgi Atanasov dwelt also on the present aggravated international situation. He stressed that the tension in the world is through the fault of the USA and its NATO allies who pursue a policy of unprecedented military preparations, and are making efforts to gain military superiority over the socialist community countries. "The policy pursued by the USA and its allies is futureless. We are optimistic because the policy of peace and detente has its mighty mainstay and material strength in the socialist community headed by the Soviet Union," he stressed. Bulgaria has given and will continue to give her worthy contribution to averting the nuclear catastrophe, to curbing the arms race, to doing away with the dangerous hot-beds of tension.

In conclusion Mr Georgi Atanasov stressed that the BCP builds her policy and activity on the ideological, organizational and tactical principles of Leninism which have been tested and verified by life.

CSO: 2200/124

LEADERS ATTEND ILINDEN INSURRECTION ANNIVERSARY

AU311950 Sofia BTA in English 1850 GMT 31 Jul 83

[Text] Blagoevgrad, 31 Jul (BTA)--Eighty years have passed of the St Elija's Transfiguration Uprising--one of the most dazzling events in the struggles of many years waged by the Bulgarian people for liberation from the Ottoman bondage. In it the population of the County of Blagoevgrad have also written down heroic pages by giving beloved victims in the battles in 1903.

On this occasion today in the historic place called "Predel" at the foot of the legendary Pirin Mountain a county meeting was held which was attended by a great number of people.

Among those who attended it were Mr Ognyan Doynov, member of the Politburo and secretary of the CC of the BCP, Mr Petur Dyulgerov, candidate-member of the Politburo of the CC of the BCP and chairman of the Central Council of the Bulgarian Trade Unions and others.

Academician Vladimir Topencharov delivered a speech. He dwelt on the aims and significance of the uprising by stressing its spontaneous and popular nature, its place in the national history as a logical continuation of the Bulgarian National Democratic Revolution, being its second highest peak after the April epic of 1876.

Further on the speaker dwelt on the political situation in Bulgaria and in the Balkans between the two centuries by stressing that the socialist ideas, the views of the radically disposed circles in Bulgaria had an impact on the ideological development of the revolutionary movement. This was a new element in Macedonian-Edirne movement influenced by the revolutionary wave in Europe which later found its highest peak in the then approaching First Russian Revolution, Mr Topencharov underlined.

The legacy of the figures of the national liberation movement has been built in the construction of socialist Bulgaria, the speaker continued. A true successor and continuer of this movement is the Bulgarian Communist Party which enriched and added to and filled with new content the patriotism and internationalism of Vasil Levski and Khristo Botev, of Gotse Delchev and Damyan Gruev, of the thousands known and unknown national heroes.

Today a gathering devoted to the 80th anniversary of the epopee of the Bulgarian people of 1903 was held in the town of Blagoevgrad with the participation of more than 300 Bulgarians who live in different parts of the planet.

CSO: 2200/124

ILINDEN INSURRECTION ANNIVERSARY MARKED BY PRESS

AU011926 [Editorial Report] Sofia ZEMEDEL'SKO Zname in Bulgarian on 31 July on pages 1 and 3 carries a 1,500-word interview with writer Kostadin Kyulyumov by Petur Petrov, devoted to the recent publication of the novel "Yane," written by Kyulyumov. The novel deals with the life of Yane Sandanski, "Great Bulgarian Revolutionary," and one of the Ilinden insurrection leaders.

In his answers to Petrov's questions Kyulyumov maintains that "the principles of the revolutionary organization created by Vasil Levski, hero of the Bulgarian liberation, have been fully applied by Gotse Delchev and Yane Sandanski," leaders of the Ilinden insurrection. Further on Kyulyumov points out the "friendly relations" between the "Macedonian Bulgarians," who participated in the insurrection, and the Bulgarian Workers' Social Democratic Party. In this context he mentions various articles written by Dimitur Blagoev on the Macedonian issue, and stressed that "these articles have been actively used in the novel "Yane."

Further on Kyulyumov dwells on Sandanski's character and history, and concludes that he was "a person born too early," and "a revolutionary who had always applied the forms and methods of the revolutionary struggle, but who also always knew when to switch from revolutionary to legal struggle."

NARODNA MLADZHZH in Bulgarian on 31 July on page 6 carries two articles devoted to the 80th anniversary of the Ilinden-Transfiguration Insurrection. The first, a 600-word article entitled "We Rebelled Not in Order to Surrender," written by Rumen Karaganev, describes the very day of the Ilinden-Transfiguration Insurrection, 2 August 1903, [under current calendar system]. The description is most factual, and concludes with the sentence: "The list of rebels who sacrificed their lives in the name of the Krushovo Republic and the freedom of the Bulgarian people is very long. The generations will always pay respect to their heroism."

The same issue carries on page 6 another 600-word article by Ivanka Stoyanova, entitled "Ilinden Resounds Throughout Europe." This article deals with the reaction of the European press to the Ilinden-Transfiguration Insurrection. The Russian newspapers NOVOYE VREMYA and SVET are quoted to the fact that "the insurrection was totally legal," and that "it is a result of the nonimplementation of Article 23 of the Berlin Treaty." Quoting briefly various British newspapers, Stoyanova claims that "it was characteristic of the foreign press to side with the oppressed Bulgarian population," and to insist that "one must fight for his freedom."

BULGARIAN NATURE OF MACEDONIA STRESSED

AU281232 [Editorial Report] The Sofia daily RABOTNICHESKO DELO in Bulgarian on 25 July 1983 carries on page 3, a 2,000-word article by Academician Khristo Khristov, entitled "The Ilinden-Transfiguration Day Uprising--A Continuation of the Heroic April Insurrection," devoted to the anniversary of this 1903 uprising against the Turks. The following introductory passage precedes the article:

"On 20 April 1903 there was an armed mass uprising of the Bulgarian and other enslaved populations against the Ottoman oppression and the declining socio-economic feudal system in Southwestern Macedonia. About 2 weeks later, on 6 August, a mass uprising broke out in Odrin Thracia. During the second half of September 1903 an armed struggle started in other areas of Macedonia, as well. It was waged by detachments and groups of the Inner Macedonian-Odrin Revolutionary Organization [VMORO] and by detachments which were transferred from the Principality of Bulgaria to the two enslaved territories."

Academician Khristov, then, proceeds to analyze the character of the uprising in connection with the preceding liberation struggles of the Bulgarian people against the Turkish oppression, describing it as a "second climax in the Bulgarian people's liberation struggle," following the 1876 April uprising.

Dwelling on the results of the April uprising, Khristov mentions the Russian-Turkish liberation war and the subsequent "restoration of the Bulgarian state," adding in this connection: "According to the 1878 Berlin Treaty, however, not all the territories inhabited by a Bulgarian population majority were granted their political freedom. These territories were mainly Macedonia and Odrin-Thracia."

Khristov notes the refusal of the Turkish authorities to implement the necessary economic and social reforms in those territories and says the population was mercilessly exploited and oppressed. He deals with the establishment of the VMORO, dwelling on its progressive and revolutionary character, pointing out that its activities were "inspired by the great Bulgarian freedom fighters, such as Botev, Levski, and Rakovski." Khristov also adds that the founders of the VMORO Modelled their statutes upon the statute of the Bulgarian Revolutionary Central Committee, established by Levski, but "they did not copy it verbatim." They just used it as a source of inspiration, Khristov remarks. He emphasizes the "consistent revolutionary democratic character" of the VMORO

statutes, demanding "equal rights and freedoms for the population of the territories which were awaiting their liberation."

Khristov dwells in particular on the strong influence exerted by the ideas of Vasil Levski, "the genius of the Bulgarian national revolution," upon the leaders of the VMORO organization. According to Khristov, this influence can be detected in the structure and local organizations of the VMORO's detachments and in all their activities. He points out, however, that differences did exist between the VMORO and the Levski organization, since they acted in different eras and under different socioeconomic and political circumstances. Khristov says in this connection: "The situation in the Balkans had changed following the 1977-78 Bulgarian liberation war. An independent Bulgarian state had emerged, becoming the support of those Bulgarians in the principality and in the enslaved territories who were outraged by the breaking up of their nation. The Bulgarian state was trying to assist the liberation struggle who were outraged by the breaking up of their nation. The Bulgarian state was trying to assist the liberation struggle in Macedonia and Odrin Thracia." Khristov points out, however, that "these efforts of the Bulgarian state met the opposition, not only of the Ottoman Empire, but also of the Great Powers, and of the Balkan neighboring countries, who were all opposed to the establishment of a united Bulgaria through the annexation of the two enslaved territories."

Khristov explains that "under the given circumstances the leaders of the revolutionary movement in Macedonia and Odrin-Thracia, in striving for liberation and for the preservation of the Bulgarian nation's spiritual unity, had no other choice than to transform these territories into autonomous regions of a future, democratic Balkan federation. Nevertheless, the idea of 'national separatism' as regards the Bulgarians of Macedonia and Thracia never occurred to them," Khristov adds and points out that this fact "is confirmed by hundreds of documents" dating from this era.

Khristov ends by reiterating that the Ilinden uprising was "the second stage of the Bulgarian national revolution" and that "it was the result of persistent ideological and organizational preparations, encompassing wide territories inhabited by a majority of Bulgarian population." Khristov adds that "representatives of other enslaved nations" participated in the Ilinden uprising and praised the "broad, social mass character of the movement" in a struggle waged "for the sake of all enslaved and oppressed nationalities and national groups in Macedonia and Odrin-Thracia." That is why, according to Khristov, the "Ilinden uprising is one of the greatest events in Bulgarian history, one which paved the way of the struggles for liberation from national and social oppression."

CSO: 2200/124

SCHOLAR DWELLS ON UPRISING IN MACEDONIA IN 1903

Sofia SOFIA NEWS in English 13 Jul 83 p 3

[Excerpts from Academician Hristo Hristov's concluding speech at an international scholarly conference in Blagoevgrad]

[Text]

Forty-two people delivered reports, communications and messages of greetings at this conference. Nine of those who read reports or statements were from abroad and the other 33, from Bulgaria. Historians from Bulgaria, the Soviet Union, Poland, Romania, Hungary, Czechoslovakia, the USA, Japan, India, Italy and Britain took part in the conference.

I must note that the participants included outstanding representatives of the historical sciences. It is especially gratifying that along with other problems of Bulgarian history, the history of the 1903 Uprising is studied abroad, too. Interest in that event in Bulgarian history is growing there, as well as in this country.

A number of important problems of the history of the 1903 Uprising were examined in the reports and communications. Especially important is the fact that it revealed a continuity of the Bulgarian national-revolutionary movement before and after 1878. The concept of the two peaks in our national revolution has been accepted and substantiated. The first peak was the 1876 April Uprising; the second, the 1903 Uprising on the Day of St Elijah and the Transfiguration.

Many reports and communications dealt with the ideological and organisational preparation of the 1903 Uprising, its outbreak, its progress in general and in individual places, and especially the course of the military operations.

Some colleagues dealt with the important point of the mass exodus of refugees and the forced exile of the Bulgarians from Macedonia and the Edirne region to the free Bulgarian state. Interesting aspects were revealed on international relations, and its repercussions in a number of European countries.

It is important to stress that we are talking about a general uprising. The very name "Uprising of the Day of St. Elijah and the Transfiguration" indicates the unity of the struggle in the two regions where that struggle was waged: in Macedonia and Edirne (or Adrianople) Thrace.

We are likewise unanimous in speaking of the 1903 Uprising as of a Bulgarian uprising, a continuation of the Bulgarian national revolution. All contributors and comrades who spoke were unanimous on that score. It is a question of Bulgarians and a Bulgarian uprising. It is not only the domestic sources which speak of such an uprising but so

do also a number of documents and newspaper reports in other countries, too. Interesting information in this respect was provided by some colleagues from Poland, Romania, Britain and other countries. It is very important to stress this, because unscientific speculations are sometimes made concerning the causes, the nature and aims of the uprising. In speaking of a Bulgarian uprising, we should naturally emphasise that it continues the traditions of the Bulgarian liberation movement of the 1870's.

In founding the IMARO, the organisers and leaders of the Uprising of the Day of St Elijah and the Transfiguration adhered to the ideas of their predecessors in the first stage of our national revolution: the time of Botev, Levski, Benkovski (leaders of the national revolution) and others.

A marked continuity is evident from the fact that although the uprising was a Bulgarian one, representatives of other oppressed and enslaved peoples took part in it, too. It is known that the documents drawn up by Vassil Levski (the ideologist and organiser of the Bulgarian national revolution) speak of a fight for a democratic republic in a free Bulgarian state in which all nationalities — Turks as well as Bulgarians — would live under the same laws and would enjoy the same rights. These ideas put

forward by Levski were adopted, further developed and applied by the founders of the IMARO during the preparation of the St Elijah and Transfiguration Day Uprising.

The conference did devote a great deal of attention to the question of ideological continuity: the Uprising of the Day of St Elijah and the Transfiguration as a development of the national-liberation struggles of the Bulgarian people in the 1870's, and later on the revolutionary struggles of the Bulgarian working class and the anti-fascist resistance during the 1941-44 period, as developments of the ideas of the St Elijah and Transfiguration Day Uprising.

In general, I believe that fresh information was provided at the conference about facts, events and trends in the development of our national revolution in connection with the Uprising.

The science of history cannot make progress without the support of documents. Hence, the enormous significance of the national and local archives in tracing and collecting various kinds of documentary material for the study of that event. By their statements our guests from abroad proved that they have a rich documentation at their disposal. New documents, new developments and — most important — new publications.

Scholars at home and abroad are often informed about an event not from our own publications but from others, who distort the truth and withhold it. It is very important therefore that we should work hard on the research of these problems. And we should cooperate with our foreign colleagues engaged in Bulgarian studies — I am encouraged by the participation of our colleagues from other countries in the scholarly conference. It is useful to remember Shakespeare's quotation that *deception never sleeps, so the truth should be repeated thousands of times*. The conference discussed some points which we should bear in mind. It was noted that the activists of the

glorious events of August 1903 fought and died in the name of the idea of fraternity, a joint struggle, for political and social emancipation. It was emphasized that they died in a land which they were to transform into a land of this fraternity of social progress achieved, and that we must transform this land into a land of peace not only for the Macedonia and Edirne Thrace regions but for the entire Balkan Peninsula, too.

We know that the work of historians should never be divorced from the given political realities and basic aims of existing societies of which the Bulgarian society and Bulgarian historians are part. But an issue of special importance arises.

How to reconcile the tendencies to consolidate this desire for fraternal relations between peoples, for peaceful co-existence and for the building of new more advanced social relations on the one hand, with the existence of class and national contradictions on the other? Or with the fact that we, historians, study the past, and the past has not always conformed with the principle of fraternity and mutual assistance? We know that history is a string of contradictory events. The Bulgarians helped the Greeks in their national revolution. Before that they participated in the Serbian revolt.

They have participated in important events in the history of the Romanian people. At the same time Romania played an important role in our history.

But along with that there have been confrontations, conflicts, contradictions and struggles.

And this is the question which we face. How we, historians, should act to promote the idea of fraternity and peace among peoples, given the existence of such conflict situations in the ongoing historical process?

I think there are two ways: the one is to study and popularise only those facts, events and processes which show and reveal the democratic character of

the historical process, the manifestation of fraternal relations between peoples. But other, non-fraternal relations of conflict do exist as well. How should they be treated? The other way is to seek the truth which should always be assessed with an eye the future, not to the past.

Balance in the assessment of history is especially important if we are to establish the facts and describe them as well as to evaluate them with respect to the notion of social progress, too. One might get carried away sometimes in revealing only the positive or only the negative side. I believe that in dealing with the aspects of the St Elijah and Transfiguration Day Uprising we should set an example by the way in which the Bulgarian historians study the past of their people in the light of the ideas of fraternity, peace and social progress.

There are people who unfairly treat that past period, distorting and falsifying it; they are guided not by the principles which guide us, our party and our state. But they have to look truth straight in the eye.

It is the duty of the historian to stick to the fundamental concept of truth, to interpret, explain and evaluate it correctly, and not to falsify it. Otherwise he would not be a real researcher and his position would be unsound.

I believe that our scholarly conference was a great success. It was attended by eminent Bulgarian scholars of different generations. But our highly respected guests from abroad contributed greatly to its high standard. I thank them very cordially for their participation in the conference and would very much like that they do us the honour to meet us again, to present our papers together, to exchange views on our common tasks, to solve the problems of the science of history.

I would like to say in conclusion that the Uprising of the Day of St Elijah and the Transfiguration did not have such positive

consequences for our people as did the April 1876 Uprising. The struggle for liberation continued after the April Uprising and it proved one of the factors that caused Russia to intervene with military force which ended the Ottoman rule and resulted in the signing of the San Stefano Peace Treaty. There were too many references to "San Stefano Bulgaria" and the Treaty as things which were the result of Russian expansionist policies in the Balkans. Our science provides a fitting answer to such views; it points out that they take no account of our national revolution as a factor which led to Bulgarian national self-determination and spurred the determination for national liberation. I believe that the national revolution was an important factor in the history of our people also during the days of the St Elijah and Transfiguration Day Uprising. But it was suppressed without leading to any intervention from the outside. Russia could not lend a helping hand to the Bulgarian people, as many of the leaders of the Uprising expected. Because of the complicated international situation, it could not come to the assistance of its enslaved brothers and of the Principality of Bulgaria. It

was only later that the Balkan War broke out, but it led to tragic events. It was only a very small part, one-tenth of the geographic area called Macedonia, about 6,300 square kilometres that was included in the territory of Bulgaria. The other parts remained under foreign government, and the developments which took place there should also be the object of our study.

I would like to add something else. Many of us often visit the district and town of Blagoevgrad. It is surprising to see how real miracles have happened in the district within such a short period; not 40 years but in some 20 years following the 1956 April Plenum of the Party. We are witnesses of the tremendous leap forward in the development of material productive forces, in the building of an enormous number of enterprises: 134. A true industrial miracle. A miracle in the development of agriculture, education and culture too. How many new people grew up here, true Bulgarian patriots, devoted to their homeland. It is a source of pride for us that precisely in this small part just a corner of Macedonia, the people live in complete freedom and enjoy full opportunities of developing their creative talents.

CSO: 2020/53

BRIEFS

FOREIGN COMMUNICATIONS VISITOR WELCOMED--Sofia, 28 Jul (BTA)--Today Mr Andrey Lukanov, deputy-chairman of the Council of Ministers, received Mr Richard Buttler, secretary general of the International Distance Communications Union, who is on a visit to Bulgaria at the invitation of the Ministry of Communications. Exchanged were views on the ways of raising Bulgaria's part as an important distance communications centre connecting the Middle and the Far East with Europe. Outlined were the trends for the country's ever more active participation in the planning of the international communications traffic. The guest was also received by Mr Pencho Kubadinski, chairman of the National Council of the Fatherland Front and chairman of the organizational committee for celebrating in Bulgaria the International Year of Communications. Mr Pencho Kubadinski made Richard Buttler familiar with the events carried out in this country in connection with the world year of communications. He dwelt on the successes made by Bulgaria in different spheres of economy. Discussed were some initiatives for starting the work of the regional communication network "Medarabtel" which includes 36 countries of the Arab Peninsula and the Mediterranean. A part of the telephone, telex and radio TV exchange of the Arab countries with Europe will pass through Bulgaria. [Text] [AU282008 Sofia BTA in English 1847 GMT 28 Jul 83]

SAO TOME, PRINCIPE PRESIDENT VISITS--Dr Manuel Pintó da Costa, chairman of the Movement for the Liberation of Sao Tome and Principe, president of the Democratic Republic of Sao Tome and Principe, and head of a party-government delegation, paid a brief friendly visit to Bulgaria today. At Sofia Airport he was welcomed by Yaroslav Radev, deputy chairman of the State Council and by high-ranking officials of the BCP Central Committee and the Ministry of Foreign Affairs. The delegation later left the country. [Text] [AU271731 Sofia Domestic Service in Bulgarian 1730 GMT 27 Jul 83]

BULGARIAN-JAPANESE ECONOMIC COOPERATION--Sofia, 11 Jul (BTA)--The 33-member Japanese financial and economic delegation, that is on visit here, today met representatives of the Bulgarian business circles. The delegation is led by Mr Mieno Yasushi, executive director of the Bank of Japan. The aim of the visit is to exchange information on the tasks the two countries are solving at present in the sphere of economy and finances. Mr Georgi Pirinski, deputy-minister of foreign trade of Bulgaria, made the guests familiar with the new economic mechanism operating in the country, with the advantages it gives to the national economic management. He dwelt on Bulgaria's foreign

economic contacts which are developing dynamically both with the socialist and with the non-socialist countries. Mr Georgi Pirinski emphasized the fact that the foreign trade of the country is increasing with every year and that in 1982 the trade amounted to about 23 million dollars. The Bulgarian Deputy-Minister of Foreign Trade commented on the development of some structure-determining branches in Bulgaria, including power generation and machine-building. Some questions of banking, of cooperation on the markets in third countries, were discussed. [Text] [AU171527 Sofia BTA in English 1324 GMT 11 Jul 83]

COOPERATION WITH AUSTRIA--Sofia, 15 Jul (BTA)--Bulgaria and Austria will intensify links of commercial, bank-and-credit, and manufacture and technological cooperation. This was the aim of the general agreement signed here today by Mr Georgi Pirinski, Bulgaria's deputy minister of foreign trade and Dr Hannes Androsch, director general and president of the board of directors of Austria's biggest bank, Creditanstalt-Bankverein. The document provides for development of relations in a great number of industries, among which the building industry, transport and agricultural engineering, and the chemical industry. Sixteen Bulgarian organizations are interested in the activization of contacts with Austrian firms with the participation of Creditanstalt-Bankverein. Dr Hannes Adnrosch had talks with the deputy chairman of the Ministerial Council, Mr Andrey Lukanov, and the president of the Bulgarian National Bank, Mr Veselin Nikiforov. [Text] [AU171527 Sofia BTA in English 1830 GMT 15 Jul 83]

FRENCH EMBASSY RECEPTION--Jean-Marie le Breton, French ambassador to Bulgaria, today gave a reception at the embassy on the occasion of the French National Holiday, 14 July. Present were Petur Tanchev; Stanko Todorov; Andrey Lukanov; Mitko Grigorov, deputy chairman of the State Council; members of the State Council; ministers and deputy ministers; chief of public, political, and mass organizations; and representatives of scientific and cultural circles. Chiefs and members of diplomatic missions accredited to Bulgaria also attended the reception which was held in a friendly atmosphere. [Text] [AU171527 Sofia Domestic Service in Bulgarian 1800 GMT 14 Jul 83]

ENVOYS MARK BOLIVAR ANNIVERSARY--On the occasion of the 200th anniversary of Simon Bolivar, the great son of the Venezuelan people and ardent fighter for the independence of Latin American peoples, Eduardo Morreo Bustamente, the Venezuelan ambassador to Bulgaria, as well as Ramses Jesus Hakim Murad, the ambassador of Colombia to Bulgaria, (Jose Ignazio Fraele), charge d'affaires ad interim of the Peruvian Embassy in Bulgaria, gave a reception at the "Vitosha" Hotel in Sofia tonight. The reception, which was held in a friendly atmosphere, was attended by the Comrades Milko Balev, Petur Mladenov, Petur Tanchev, and Andrey Lukanov, as well as by deputy chairmen of the State Council and the Council of Ministers, by ministers, deputy ministers, leaders of sociopolitical and mass organizations, by representatives of cultural and business circles, as well as by chiefs and members of diplomatic missions accredited to our country. [Text] [AU260847 Sofia Domestic Service in Bulgarian 1900 GMT 25 Jul 83]

JAPANESE FOREIGN MINISTER TO VISIT--Sofia, 25 Jul (BTA--Mr Shintaro Abe, minister of foreign affairs of Japan, will pay an official visit to Bulgaria early in August at the invitation of the Bulgarian minister of foreign affairs, Mr Petur Mladenov. [Text] [AU251642 Sofia BTA in English 1455 GMT 25 Jul 83]

USSR RAIL LINK PROTOCOL--Considerable work was accomplished during the last 12 months in connection with improving the transport relations between Bulgaria and the Soviet Union in accordance with the directives mapped out following the Moscow meeting held in 1982 between Grisha Filipov, chairman of the Council of Ministers, and Nikolay Tikhonov, USSR Council of Ministers chairman. This was stated during the talks held between Vasil Tsanov, Bulgarian minister of transportation, and Nikolay Konarev, USSR minister of railways. The two ministers adopted a decision on a new, qualitatively improved development of the cooperation between the two fraternal countries in the railroad transportation sector in order to achieve synchronization in this sector. For this purpose it was decided to improve the use of trains on scheduled services, and to increase the cargoes on the Varna-Ilichovsk ferryboat line, as well as transport in containers, pallets, and packages, and to expand the transport capacity of the railroad lines to the ferryboats, to the border stations, and ports. It was decided to organize accelerated test transports with special scheduled trains for perishable food products shipped from Bulgaria to the Soviet Union. It was ascertained that the volume of the envisaged transports from one country to the other by railroad and ferryboat has been exceeded during the first 6 months of the year 1983. The two ministers signed a protocol in Sofia yesterday on the new agreements reached. Leonid Grekov, USSR ambassador to Bulgaria, attended the signing ceremony. [Text] [AU261257 Sofia RABOTNICHESKO DELO in Bulgarian 24 Jul 83 p 4]

KUBADINSKI REVIEWS FORTHCOMING ELECTIONS--A conference on the forthcoming elections for people's councils, mayors, and people's councillors at the municipalities scheduled for 4 December has been held at the Fatherland Front National Council. Comrade Pencho Kubadinski spoke about preparations and carrying out the elections. Party and state figures, chiefs of public organizations, creative unions, and representatives of the mass information media attended the conference. [Text] [AU281635 Sofia Domestic Service in Bulgarian 1500 GMT 28 Jul 83]

CSO: 2200/124

FURTHER ON RELEASE OF IMPRISONED FRANCISCANS

LD281508 Vatican City in English to Central and West Europe 1345 GMT 28 Jul 83

[Text] Vienna--According to an AP report, three young Franciscan friars have been unexpectedly released from prison in Czechoslovakia after being held for 4 months without trial, Austria's Roman Catholic news-agency, KATHPRESS, reported yesterday. Jaroslav Brazda, Peter Rucka and Anton Smid were freed from a Bratislava jail without explanation, KATHPRESS said. No date was given for their release. The three have become an underground cause in Czechoslovakia after their arrest on 27 March, in what has come to be known as the Palm Sunday raids, a series of police (?raids) against believers. Their pictures and descriptions circulated in underground leaflets and thousands of Czechs and Slovaks protested the raid in open letters to government and church leaders.

Two other Franciscans, Josef Mazanec and Frantisek Pometlo, were sentenced this month to 6 and 8 months in jail respectively for having unauthorized literature and for inducting another young believer into the order. According to KATHPRESS, church leaders in Slovakia said the release came as a complete surprise. The three had been expected to stand trial soon for violating laws regulating religious practice.

CSO: 2020/54

PACIFIST APPEALS TO HONECKER, UN SECRETARY, FRG PARTIES REPORTED

'Letter to Honecker' Controversy

Frankfurt/Main FRANKFURTER RUNDSCHAU in German 14 Jun 83 p 1

[Report by Karl-Heinz Baum, correspondent, FRANKFURTER RUNDSCHAU, datelined Rostock, 13 Jun: "Bishop Sees no Reason Why Christians Should Leave GDR-- Rathke Does Not Believe State Locks People Out"]

[Text] According to the views of Mecklenburg Land-Bishop Heinrich Rathke, Christians living in the DDR have no reason to leave the DDR. At a press conference on occasion of the conclusion of the Evangelical Church convocation of the Regional Churches of Mecklenburg and Griefswald, which had the motto "Dare to Have Faith," Rathke declared that he said to each Christian, "I can give you only one advice: if you ever want to find out what belief is all about, then stay here, and dare to have faith." This also is the answer to each Christian, who comes to him with an application for emigration. Rathke reminds people that he himself came to the DDR from the Federal Republic some 30 years ago.

Whoever submits an application for emigration does a disservice to himself and to the worldwide peace effort, if he believes that this would be a means to leave the DDR. With regard to the Jahn case in Jena, the bishop said that he did not know whether reports that people were forced to leave the DDR were correct. He would like to know the circumstances, but did not however believe that a state would lock out its citizens. He would, as bishop of a church, like to have coworkers who willingly remain in the country. In discussions with state authorities he again and again had pointed out that it was necessary to create conditions where such reasons for emigration would not exist.

In answer to a question why a letter of several Rostock youths to the DDR State Council Chairman Erich Honecker, which had been posted in St Mary's Church during the church convocation, had been removed by the church administration, Rathke replied that he supported the contents of the letter, in which Honecker was asked to work towards toleration of independent peace declarations of Christian groups during state sponsored peace meetings, after FDJ [Free German Youth] flag bearers had pushed a group around after a Whitsun assembly in Rostock. The letter was only a personal message which had been posted without signatures, for all to see. He had in the meantime discussed this breach of etiquette with the group.

Letter to UN Secretary

Frankfurt/Main FRANKFURTER RUNDSCHAU in German 14 Jun 83 p 1

[Report by Karl-Heinz Baum, correspondent, FRANKFURTER FUNDSCHAU, datelined 'Berlin (Reuter)': "Deported Jena Pacifist Presents Petition to UN General Secretary"]

[Text] Roland Jahn, who was expatriated by force from the DDR appealed on Monday to Un General Secretary Perez de Cuellar to support his cause during a visit by the General Secretary in the DDR towards the end of the month. Part of the appeal, which was accepted by Perez, reads: "I would like to ask, that you support my cause in your discussions with State Council Chairman Erich Honecker, that my forced deportation be cancelled." Perez stayed in Berlin for a 24 hour visit, starting Sunday afternoon.

Jahn also asked Perez to intercede with the DDR Government in behalf of his friends of the Jena peace community, who had emigrated to the Federal Republic under psychological pressure. They also should be permitted to return.

Letter to Bundestag Parties

Frankfurt/Main FRANKFURTER RUNDSCHAU in German 14 Jun 83 p 4

[Text of expatriated Jena dissidents' appeal to the Bundestag parties, 12 Jun 83: "Disarmament Has to Start First in Our Own Heads"]

[Text] From their "exile" in West Berlin, 22 recently expatriated DDR peace movement members have taken a stand against further stationing of missile systems in Western Europe. The position about the NATO rearmament, which was transmitted to the Bundestag reads as follows:

"During the last five years about 80 to 100 Jena citizens have been expatriated, among them 40 activists and sympathizers of the peace movement in the DDR. Also a large part of the persons who were arrested after the minute of silence for peace on Christmas Eve 1982 are now living in West Berlin. Thanks to the solidarity of many people in the West these friends of peace were, for the time being, permitted to return to the DDR. Some of these, based on bad experiences in the DDR, have voluntarily left their homes. The majority of the people involved were forced to emigrate.

"We, the expatriated Jena friends of peace, appeal with this declaration to the parties in the Bundestag, to the peace movement, and to all people of good will. In Jena we stood against a militarization of everyday life and for a democratization of society. The experiences which we had to suffer as a consequence did not just begin in 1976 with arrests and forced expatriations following the protests against the Biermann expatriation. Even before that time severe clashes with state organs occurred in Jena for political reasons. After 1976 we demanded not only more democracy in Jena, but also disarmament

and peace. Human rights and peace are indivisible for us. Wherever people are suppressed because they have political, religious or pacifist convictions which differ from the state doctrine, as is the case in East European countries, there is no peace. Almost all of us have experienced this non-peace: investigations, blackmail to recruit informers for the State Security Service, day-long surveillance, prohibition of certain occupations, dismissal from schools, incarcerations, forced expatriation, and finally the murder of our friend Matthias Domaschk in the State Security Service detention pending trial in 1981.

"In our country we have supported disarmament both in the East and in the West. This we also will do here. Even though we now must live in West Berlin, we have close ties with our friends in Jena, Berlin, Halle, Cottbus, Dresden, Schwerin and many other cities in the DDR. Stationing of Pershing II and Cruise missiles in the Federal Republic will increase the political pressure on our friends in the DDR. We cannot agree to the stationing of weapons which are pointed towards people who put their lives on the line to fight against similar weapons systems in their countries. We have recognized that not only in the DDR enemy pictures are used to create hatred, but also here. Disarmament must therefore start in all of our own heads. Please stand with us against stationing of further missile systems in Western Europe and for comprehensive disarmament in both West and East."

7994

CSO: 2300/301

REGIME SEEN BEGINNING TO ACKNOWLEDGE CHURCH-LED PEACE MOVEMENT

Frankfurt/Main FRANKFURTER ALLGEMEINE in German 5 Jul 83 p 3

[Article by Peter Jochen Winters, datelined Berlin, 4 July: "Free Exchanges Under Church's Cover--Peace Workshop in East Berlin for Second Time--Bishop Speaks, Responds to Questions"]

[Text] The area around the Protestant Redeemer Church in East Berlin's Rummelsburg district is firmly in the hands of the state security service. The conspicuously inconspicuous young men patrol not only the streets and railroad tracks immediately adjacent to the church grounds, they also mingle with the visitors to the peace workshop held here in the church and on the large church grounds for the second time after having its first run last year. Before the beginning of this event which is sponsored by the Berlin-Brandenburg church administration and the East Berlin City Youth Paris Office and which begins at ten in the morning with a church service and ends in the evening with another church service, there were all kinds of disagreements between promoters and participants and also with state authorities. Which activities promoting peace in the country itself and toward the outside may the church allow? Where must the church apply the brakes or refuse completely? Which groups may set up booths at the "market of possibilities" in the shadow of the church building? What may they exhibit and produce there? Who may participate in panel discussions and who may not? The church decided in favor of plurality without accepting anything.

The peace workshop visitors who come in large numbers not only from East Berlin parishes do not know much about these problems. Their minds are occupied with talks on the possibilities of church peace work and information exchange among individual groups. They come to the overcrowded Redeemer Church were, following church services, lectures are given among which Stefan Heym's lecture in the afternoon attracts the greatest attention. Also in the afternoon the following people participate in a panel discussion: Pastor Tschiche, director of the Magdeburg Protestant Academy, who sits next to East Berlin Pastor Eppelmann, considered one of the most determined peace activists in the GDR, also the official CDU functionary Carl Ordnung, who is a member of the GDR "state" peace movement, the Peace Council, and also the regional secretary of the Christian Peace Conference (CFK), as well as writer Rolf Schneider, who confesses to being an atheist and uncompromising pacifist, and one of the young women who is active in the initiative "Women for Peace."

All of these participants sit peacefully next to each other on the platform in the Redeemer Church in order to talk to each other and with several pastors, as well as with the new East Berlin General Superintendent Krusche about the possibilities of being active for peace. Several participants complain about the gap between the GDR's peace demonstrations toward the outside and the country's lack of peaceful attitudes on the inside.

But at least there is discussion. Church peace activists and government peace supporters are listening to each other, they exchange arguments and offer themselves to the judgment of the many interested listeners. The following impression becomes clear: the SED statement that in the GDR there is only one peace movement, the official one, the one sponsored by the government and represented in the Peace Council, has become weak even in the minds of the "peace functionaries." They can no longer ignore the original, independent church peace initiative or push it into a state of illegality. The recipe by which the FDJ acted at Pentecost has proven itself wrong and dangerous: there many Christian young people who wanted to participate with their own posters and slogans in the peace rally sponsored by the FDJ not only had their posters torn up and were themselves beaten up; much good will and honest effort toward cooperation with respect for individuality was there destroyed. In the Redeemer Church one almost has the impression that restitution is to be made here. Whether this impression is correct will be shown in the next few days by government reaction to these events.

Approximately 3,000 persons come to the peace workshop in the course of each day. They are primarily young people, a surprisingly large number of young couples with small children. The whole scene looks like a country fair sponsored by the "alternatives"--you can also see a few punks who otherwise are rarely seen in East Berlin--and all of this is on the outside hardly different from similar events in the West. But here in the regimented, uniform and uniformed socialist society it is quite a decision with potentially very negative results when somebody not only wears alternative clothes but also thinks in alternative ways and meets with like-minded people for a free exchange of ideas on the grounds and under the protecting hand of the church. Some people might be quite apprehensive about coming here, passing by the state security officials who observe the scene with interest and always take notes. But the feeling of belonging to so many who also have their own ideas and refuse to think along prescribed tracks gives strength and self-confidence. Quite a few who come here are church-oriented, to be sure. But many also come because they look for elbow room and are curious to find out how others handle the difficulties of their existence. People so far classified as minorities in the GDR are allowed to raise their heads here, to show their flags; one of the many booths in this market of possibilities was set up by homosexuals who offer opportunities for dialog and information.

The Redeemer Church peace workshop is a little like a small church meeting. On the church grounds a variety of booths--from the Christian Peace Conference to the pacifists, from the synod of the Federation of GDR Protestant Churches to the initiative "Women for Peace"--have been set up where by displaying posters, photos, written texts and pictures as well as through talks participants report on their activities and achievements. Some peace group will talk

about its experiences with state security authorities during bicycle ride demonstrations in East Berlin and its surrounding areas. Somewhere else a cameraman reports that his determined pacifist attitude has cost him his job, and at another booth you hear that the atom bomb in the hands of the working class is not an evil but something good. At another booth law synopses on questions of military service, the right to assemble and environmental protection are sold. Not far from that booth, somebody very seriously reads from the official GDR civil defense manual, what you should do in case of a nuclear attack.

East Berlin Bishop Forck, whose black suit already draws attention, wanders from booth to booth, then climbs on a chair and with his back to the church wall answers questions without using a microphone. He reports that the church is ready to work for the repatriation of Ronald Jahn, the Jena peace activist who was recently removed from the church* against his will and by force. Forck also states that during his detention Jahn had filed a legitimate petition to move to the West and had retracted it later but only orally not in written form as required. Before the church can work in behalf of his return, Jahn must submit a signed application for permission to return.

The bishop gives information about the recent arrest of Deacon Rochau in Halle. The reasons for his arrest are not yet clear, state authorities have reported that the arrest was not connected with his church activities. There might possibly be a connection with a previous arrest of four people in Halle who some time ago applied for permission to move to the West and demonstrated on this behalf. Until the end of February Rochau was working at a parish in Halle-Neustadt where he was in charge of "open youth work" which deals with socially endangered people. In this capacity he had several confrontations with state authorities. But in his parish the young deacon also had difficulties which finally led to his dismissal. He is still associated with the church but his arrest happened at a time when he had finished one assignment and not yet started another. The Magdeburg church to which Rochau, who by the way does not want to leave the GDR, belongs has called on its parishes to pray for the deacon.

Bishop Forck then talks about actual concerns of the church. Under its roofs the church tolerates a broad spectrum of peace and environmental activities, but it cannot identify with all of these. Therefore there are always disagreements with individual peace groups. On one point, however, church and peace groups seem to agree: neither wants anything to do with people who work for peace in the GDR only to speed up their chances to move to the West. To be sure, the church continues to be concerned for those who have filed emigration applications, but the church does not want that those willing to emigrate present a peace activist profile in order to facilitate their applications. Peace and ecology groups seem to feel even more strongly about people who really want to leave the country and see in their commitment a way to reach this goal faster. "We want to live in the GDR and work here for peace and environmental protection because this is our homeland. Moving to the West is no alternative for us."

*Thus the German text. This is probably a mistake because Jahn is reported to have been expelled from the country not the church.

IDEOLOGICAL DIVERSITY OF 'FRIENDSHIP GROUPS' SEEN IN POSITIVE LIGHT

East Berlin NEUES DEUTSCHLAND in German 8 Jul 83 p 2

[Article signed 'H.B.': "On the Greeting Message of Friendship Societies-- Friendship Among Peoples Strengthens Peace"]

[Text] Sixty-four national societies for friendship with the GDR are active in 56 capitalist industrial countries and young nationalist countries. The presidents and general secretaries of these societies who met in Berlin for an exchange of opinions and experiences addressed in the beginning of this week "greetings to the people and government of the German Democratic Republic." This message, which was signed by them, was the result of animated meetings with citizens of our country and of consultations with the GDR League for International Friendship. In this message the signers expressed confidence in and recognition of the logical and constructive peace policy of our country.

In their own countries the representatives of the friendship movement enjoy high esteem--whether as representatives of workers' parties or unions, as tradesmen, businessmen, farmers, scientists or artists, managers or religious dignitaries. As state assembly members or local political activists as well as representatives of very different parties they exert considerable influence on the social life of their country. Irregardless of their often very different political and philosophical positions, they jointly work for the confidence and friendship of their countries toward the GDR.

They are active--and many of these societies have already existed for more than two decades--in establishing good relations and developing a mutually advantageous cooperation with the German workers' and farmers' state. In this work they proceed from the assumption that activities of this kind are profitable to the national interests of their own countries as well as to the preservation of peace. They do this work primarily by spreading patiently and through a variety of means their knowledge of the GDR.

They considered the exchanges of opinions and experiences among themselves as well as with the League for International Friendship especially urgent in this year. This feeling was based on the realization that the policies of confrontation and intensified rearmament of the U.S. administration and its NATO allies put in question all of the understanding and community spirit created

by the friendship societies. In spite of the many different concrete social conditions they represent, these representatives of friends of the GDR on all continents were of the opinion that the plan to station new American nuclear weapons in Western Europe jeopardizes not only friendship and cooperation between countries but the existence of mankind. From this they concluded that it has never been as necessary as it is today to oppose the distortions of international propaganda with the ideas and practice of international friendship and the destabilization of international relations with cooperation.

It was significant that many speakers who subscribe to neither Marxism nor socialism exposed the anti-communism and the hysterical slander of the Soviet Union, the GDR and other brother countries for what it really is--psychological warfare. No matter whether they are neighbors of the GDR, or live in Northern, Western or Southern Europe, or far away in Asia, Africa or South America, the participants emphasized their determination to work actively for trust and friendship toward the GDR among the people of their countries and to make determined efforts against warmongering as well as anti-communist slander.

There are many different motives for this interest, sympathy and friendship toward the GDR. But in all this variety of motives on the part of specific groups or individuals active in them there is a very important common agreement. For all, their closeness to us is based on the realization and appreciation of the fact that the logical struggle for peace, the preservation of the heritage of international struggle against fascism, and the spirit of solidarity are to an equal degree popular sentiment and government policy.

No nation--the participants declared--feels threatened by the GDR. Experience shows that the GDR is always a predictable, reliable and in many respects valuable partner for other peoples and countries. The friends of our country are convinced in their knowledge because they know that our policy is oriented toward the well-being of the people and toward peace, and that this policy is realized through the hard work, the initiative and creativity of millions of workers.

Many of our friends may have different ideas about the future development of their own countries than we have about the future of our republic. This is only natural. But the stable and dynamic development of our economic and social policy, social security and freedom, the clear perspectives and the vitality of our young people are facts that are extremely important and interesting for our friends. They worry about the condition of many of their countrymen who, primarily as the result of intensive rearmament have been hit by unemployment, inflation, by despair among large segments of the young generation, by the lack of housing, by social decay, by the low level of education, poverty and alienation. For many of our partners the meeting with the realities of the socialist GDR is stimulating and encouraging. During these meetings we do not in any way pass over the problems that arise in the course of our progress and during the development of a new, humane society.

The participants show sympathy for our plans that reach far into the future. It is clear to them that peace is the indispensable condition for these plans. Some of our friends are especially interested in strengthening our cooperation and exchanges to mutual advantage. In this they see opportunities to secure work and profit. But this, too, requires peace.

It is especially for these reasons that our friends are in favor of continuing the policy of detente, and that they will spare neither efforts nor sacrifices to preserve and expand the friendship which we have built in joint efforts with them, and to defend with all the means at their disposal these achievements against the crusade ideologists whose efforts are harmful to the people's interests.

We who are conscious of the strength that emanates from our firm friendship and alliance with the Soviet Union and the other brother countries are glad to have so many good and faithful friends in all continents and regions of the world. We assure them emphatically that in the GDR they have a reliable partner on whom they can always depend.

8889

CSO: 2300/315

BASIC MOTORIZED RIFLE TROOP VEHICLE DESCRIBED

East Berlin AR-ARMEERUNDSCHAU in German No 7, Jul 83 (signed to press 19 May 83)
pp 28-32

[Article by Maj Ulrich Fink: "BMP--The Tank of the Motorized Riflemen"]

[Text] Four armored personnel carriers grind forward at high speed over the maneuver terrain. Armored infantry, assigned by their battalion commander to reconnoiter the battlefield. Suddenly the first vehicle comes to a halt, moves back a short distance, seeking cover in a slight depression. Through built-in periscopes the vehicle commander and the gunner observe the terrain. Their particular attention is called to a tank barrier erected from uprooted trees. From the two rear doors of one of the accompanying vehicles four armored infantrymen clamber out. By twos they creep forward to the obstacle. Four others follow with mine detectors. The tank barrier is not mined. Working together, the soldiers clear away the tree trunks and creep back, alternately covering each other, and disappear into their BMP. This is the abbreviation for Boyevaya Maschina Pechoty (Infantry Assault Vehicle). Its tracks enable the armored infantrymen to work closely with armored units in combat situations. The forward drive wheels for the tracks take their power from the six-cylinder, four-cycle diesel engine by way of clutch and transmission mechanisms. The tracks, covered on their outside by convex metal shields, are each drawn over the six road and three bogie wheels. Their individual treads are connected by rubber/metal couplings. The engine with its clutch and transmission, cooling system, air filter, compressor and water pump is housed on the right in the bow of the hull. Separated by a bulkhead from the engine compartment, the driver is seated in the front left of the hull. All controls and gauges are arranged with easy visibility around his station. Even a gyrocompass is part of this array, being used to aid the driver in maintaining direction when moving over water. Despite its 13-ton mass, the BMP is amphibious. When crossing rivers and lakes it can maintain speeds of up to 7 kilometers per hour. Over-water propulsion is achieved through the tracks, whose treads are provided with small vanes on their rolling surfaces. Thus the tracks operate in the water like the paddle wheels of an old-time river boat. A splash board at the hull's bow prevents the BMP from being inundated by waves. The engine is protected against water intruding into the engine compartment by a collapsible air intake pipe and automatically closing valves.

In the event of hostile nuclear weapons being employed in the combat zone, an automatic mechanism cuts off the engine and closes the cooler louver. In addition, the air intake device and its conduits to the ventilators in the turret and the crew compartment are closed. The ventilators and the main compressor also turn off automatically. At the same time that these precautions

are being effected, a filter system goes into operation purifying the exterior air.

For protection against the effects of infantry ground fire the forward wedge-shaped end of the vehicle's hull and its turret are lightly armored. The gunner is seated in the turret and operates the BMP's weapons system. Included in this are the 73mm smooth-bore cannon, the coaxially arranged 7.62mm PKT machine gun to its right and the anti-tank guided missile. The missile launcher is operated by hand through a hatch in the turret. Rounds are fed to the cannon automatically; the machine gun is belt-fed. All ammunition is arranged around the gunner's position.

To the left of the turret is located the vehicle commander's position with the commander, the driver and the gunner each having a separate entry hatch above his seat. They have available to them daylight and night-sighting devices enabling them to observe the battlefield and to direct fire with high precision at all times.

In the aft crew compartment of the armored personnel carrier, benches are located on both sides of the battery lockers and the main fuel tank, with room for four infantrymen. The armored construction of the personnel carrier is designed primarily for their protection when they are engaged in joint operations with armored forces at speeds of up to 45 km/h over open terrain and at 60 km/h over paved roads, both of which the BMP can achieve with ease. There is a firing port for each infantryman on the vertical side walls, through which fire can be delivered while in motion. Within the troop compartment two light machine gun mounts and six assault rifle mounts are positioned on the side walls for this purpose. Above each weapon mount hangs an exhaust cone which is drawn down over the breech of the weapon during firing so that detonation gases are not dispersed within the vehicle. With its fire power and its combat effectiveness the 6.9m long, 2.85m wide and 2.5m high BMP is far more than a troop transport vehicle. Its exceptional running characteristics, its fire power, the protection which it offers its occupants against various forms of munitions--all of this makes the BMP an outstanding piece of military technology, namely an armored personnel carrier which has demonstrated its merits for more than 15 years. Yet even in this sector of military technology development continues. The armaments buildup of the forces of imperialism obliges the Soviet Union to modernize its weapons as well.

On 7 November 1982, a Guards unit of the Soviet Army demonstrated a new model of the BMP during a parade on the occasion of the 65th anniversary of the founding of the USSR. This model of the armored personnel carrier also enables infantrymen to deliver fire without dismounting and can offer effective support to the dismounted armored infantrymen when dismounted. Like its predecessor, this armored personnel carrier affords protection to the soldiers in its interior from the effects of hostile conventional weapons and mass annihilation weapons. Special filters are built into the ventilation system for protection against chemical agents. A smoke delivery system can create smoke cover for camouflaging the vehicle. Improved fire power of the new BMP is evident from the machine cannon in the flat turret and the modern anti-tank guided missile mounted in a container on its side. Its weapons array is sufficient to deal with armored vehicles, low-flying airborne targets and hostile ground fire.

Armored Personnel Carrier BMP

- | | |
|---------------------------------------|--------------------------|
| 1. Hull | |
| 2. Erectable wave breaker | |
| 3. Deck plate | |
| 4. Instrument panel | |
| 5. Driver's periscope | |
| 6. Operating lever for driver's hatch | |
| 7. Engine | |
| 8. Louver operating lever | 32. Track support roller |
| 9. Air filter | 33. Firing ports |
| 10. Vehicle commander's seat | 34. Gun sighting system |
| 11. Cannon | 35. Infantry periscope |
| 12. Anti-tank missile mount | 36. Steering lever |
| 13. Anti-tank guided missile | 37. Gearshift |
| 14. Turret | 38. Track tension device |
| 15. Searchlight | |
| 16. Gunner's seat | |
| 17. Fuel tank | |
| 18. Bench for armored infantry | |
| 19. Battery | |
| 20. One-man anti-tank missile | |
| 21. Rear door | |
| 22. Rear firing port | |
| 23. Track | |
| 24. Road wheel | |
| 25. Torsion bar | |
| 26. Engine compartment bulkhead | |
| 27. Driver's seat | |
| 28. Clutch pedal | |
| 29. Driving pedal | |
| 30. Generator | |
| 31. Idler wheel | |

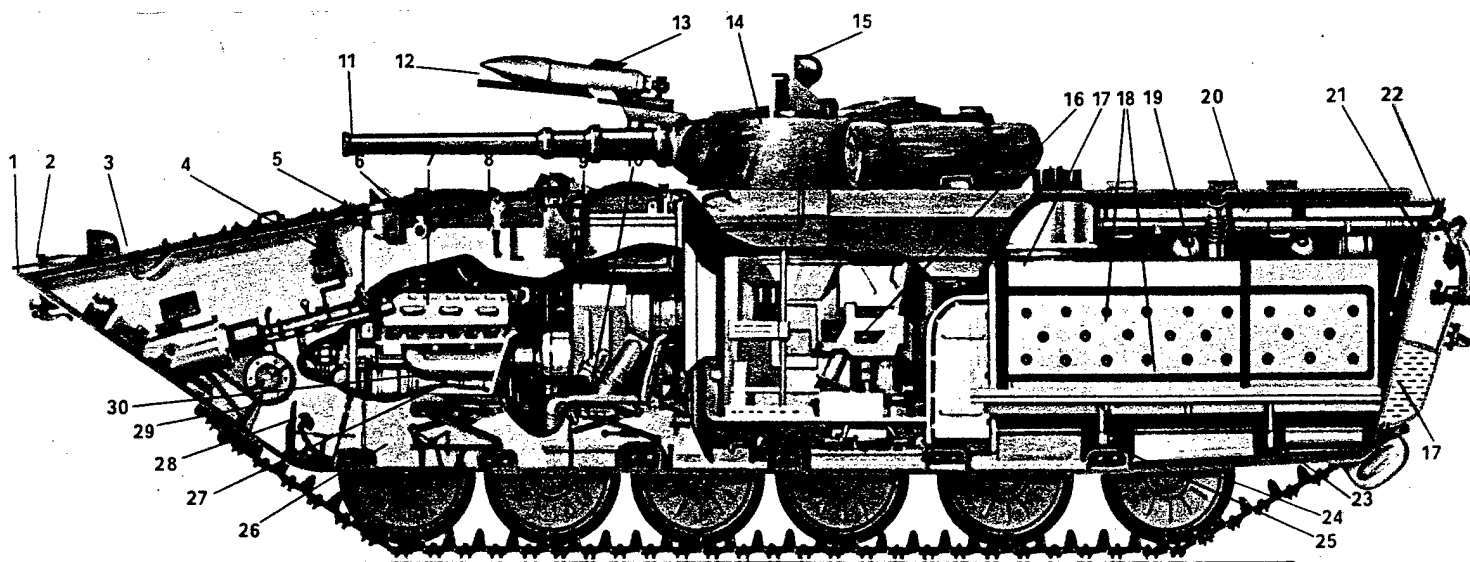
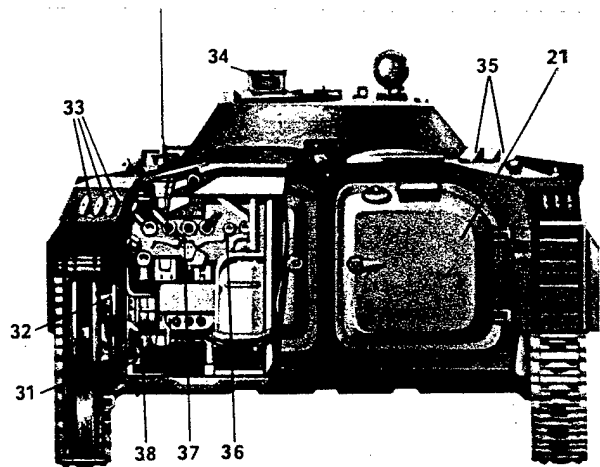

MILITARY INNOVATORS CITED IN CONSERVATION EFFORTS

East Berlin PRESSE INFORMATION in German No 78, 7 Jul 83 p 5

[Article by Lt Gen Manfred Gehmert, chief, Neubrandenburg Military District: "NVA Innovators Are Making an Important Contribution Toward Greater Combat Strength and Combat Readiness"]

[Text] In the balance sheet of the successful development of the innovator movement within the National People's Army, a worthy entry has been posted with the results of innovation efforts in the Neubrandenburg Military District. These are an expression of a genuine creative effort on the part of members of the Army and its civilian employees in the interest of fulfillment of their class mandate.

The efforts and the successes of the innovators serve primarily the intensification of combat training, the enhancement of combat readiness of units at all levels and the permanent deployment capability of weapons and technical equipment.

Clear Tasks Set

Based upon the high demands set by us as well as the requirements of scientific-technical progress and their impact upon the military, we have oriented the initiatives of the innovators and inventors toward the development of simulators, modern training aids and facilities and the improvement of organizational maintenance technology. Great stress is also placed upon the most efficient use of material, energy, heating and motor fuels and lubricants, including the maximal utilization of secondary raw materials.

The appropriate tasks, thoroughly worked and jointly discussed in advance, are laid down in an innovation plan. This is of great importance if only because the necessary preparations for its transfer into military practice can then be promptly instituted.

Our experience shows that together with a clear cataloging of goals and precise control over their realization, the speedy application of such innovations is the most effective stimulus for innovations. The development of the innovator movement in the Military District makes this very clear. A few figures and examples can demonstrate this. During the first 6 months of the 1982/83 training year, 3,343 innovators and 1,328 innovator collectives submitted a total of 2,150 innovations. Of these some 1,929 have already been accepted for use. By contrast with the first training semester of 1981/82, the collective innovator activity had risen by 29.5 percent and the participation of members of

the Army and civilian employees by 22.8 percent.

Of these results, about half served for the intensification of combat training and thus the enhancement of combat effectiveness and deployment readiness of the military collective. Patents were granted for five inventions; these were primarily aimed at the improvement of organizational maintenance technology. As a result of these innovations, substantial military-economic results have also been achieved, resulting in economies in electrical energy, solid fuels, motor fuel and spare parts.

Close Collaboration with Soviet Brothers in Arms

A solid tradition is to be found in the close cooperation which has existed for years between our innovators and the efficiency study experts at all unit levels of our Soviet brothers in arms. This is founded on carefully worked out plans and concentrates on the exchange of experiences and innovations as well as the joint realization of projects. At present there are 33 such agreements. Reciprocal visits and the display of innovations at military technological exhibitions and conferences of innovators serve to supplement the cooperative efforts with the efficiency study experts and innovators from the "the regiment to our flank" and frequently give birth to new ideas.

The total of accomplishment so far does not, however, mean that all our opportunities have been exhausted nor that everything runs without hitches. What I see here is primarily the potential for still more members of the Army and its civilian employees to become engaged in this very significant effort toward enhancing our combat readiness.

The positive course of innovation activity in the Military District is based specifically upon the effective direction of this movement by unit commanders, the political authorities; party, FDJ and trade union organizations; the close linkage of innovator activity and socialist competition as well as the use of material and psychological incentives. We have a solid base to build on such that we will be able even in the future to fulfill the objectively growing tasks in the area of innovator activity and thus to achieve even further progress in enhancing our combat strength and deployment readiness.

9878

CSO: 2300/326

CHURCH URGES RELIGIOUS EDUCATION FOR CHILDREN

Budapest UJ EMBER in Hungarian 12 Jun 83 p 1

[Article by Maria Galantai: "Before Registration for Sunday School"]

[Text] Usually, during mid-June, we are still evaluating the past school year and making summer plans. With these tasks at hand, we are apt not to listen to the words of Jesus which speak directly to us at this time: "Suffer the little children to come to me!"

In his letter to the Catholics of Hungary, our holy father Pope John Paul II asks us to consider this: "The church has always held catechism to be a basic responsibility, in the spirit of the Lord's last words: make disciples of all nations, and teach them to keep His Word.... Catechism is a path which must make living contact with Christ's Person possible through faith...from childhood to the threshold of maturity, catechism must be the constant school of faith and the guiding light for the way of the child, adolescent and young adult."

The teachings of the council and the inspiration of the pope remind Christian parents of their responsibility for the spiritual education of their children, not only through a religious home atmosphere and daily Christian example, but also through regular religious education. Our laws provide for this.

It is stated in our constitution: "The Hungarian People's Republic guarantees the right to freedom of conscience and the practice of religion to its citizens." (Paragraph 63, point 1)

The 1976 decree of the Presidential Council of the Hungarian People's Republic number 8, clause 18, states: "Everyone has the right to freedom of thought, conscience and religion.... No one can be coerced into limitation of his freedom to have his own opinion or religion...." (The nations accepting the UN charter, thus Hungary also:) "...commit themselves to upholding the right of parents or legal guardians to arrange the religious and moral education of their children according to their own convictions." (MAGYAR KOZLONY, 22 Apr 76)

Despite all this--as our cardinal pontiff mentioned in a television documentary--there are negative associations with religious education. It has

happened that parents have been discouraged through various means from registering their children for religious education. Yet the edict concerning religious education (1957. III. 24) states:

"1. Paragraph 2. The right to participation or non-participation in religious education must be upheld for everyone. Those committing the acts hereinunder must be prosecuted:

- a) using religious education as a political tool against the state, social or economic order of the Hungarian People's Republic;
- b) attempting to use force or threats to influence the decision to participate or not to participate in religious education;
- c) using threats or force to bar participation in religious education, or the education itself."

The new Penal Code, which came into effect 1 July 1979, states in paragraph 22: "Any legal entity who, through admission or testimony, is found to have used force, threats or other similar methods, is guilty of crime and is punishable by 5 years' loss of freedom."

It has also happened that children attending religious education have been put into a disadvantageous position at school: schoolmates have shamed or ridiculed them. Yet according to paragraph 156 of the new Penal Code, "Whoever causes serious mental or physical injury to a member of any national, racial or religious group because of his membership in that group is guilty of a crime, punishable by two to eight years' loss of freedom."

Thus our laws clearly state: parents have nothing to fear if their conscience dictates that they should have their children participate in religious education. In the few remaining days before registration begins--we will publish the exact time in a later issue--let us become aware of our responsibility. At our children's baptism, we made formal vows before the whole community to uphold what the Holy Spirit inspires us to do through the words of the Father and the council. Let us do everything in our power--for the sake of our children--to uphold these vows.

9890
CSO: 2500/324

SZARAZ DISCUSSES DEVELOPMENT OF HISTORICAL AWARENESS

Budapest NEPHADSEREG in Hungarian 19 Mar 83 p 13

[Interview with Gyorgy Szaraz, new editor-in-chief of KORTARS, former editor of ELETES IRODALOM, by Istvan M. Katona, senior correspondent at NEPHADSEREG; "On the Formation of Historical Awareness"; date and place not specified; passages enclosed in slantlines are printed in italics]

[Text] One who wishes to keep current with the literature that analyzes and explores our historical past and aids in the formation of national identity finds himself confronted by a dizzying profusion of facts and interrelationships. But it is also obvious that in addition to a knowledge of historical facts, it is important in any case to rid public opinion of misconceptions relating to historical awareness which may still be found today. However, this is hardly possible without clashes of views and opinions. How might we try to orient ourselves in this discussion, and how does the citing of history affect the formation of our attitudes? Istvan M. Katona, senior correspondent at our paper, discusses these with writer Gyorgy Szaraz, editor-in-chief of KORTARS.

[Question] /Recently, history has become a center of interest. We may read books on historical subjects and personal memoirs about events in our recent and centuries-old distant past. Book publishers also devote series to the publication of works illuminating the treasures of our past. After summarizing these diverse facts, is it possible for our consciences to be satisfied that there are no problems with the formation of historical awareness, and that we understand and are familiar with our past?/

[Answer] Nowadays, we may encounter two types of generalizations. One is that history interests everyone. The other is that in our "fast-moving" age, no one is interested in history. And, as it usually is with generalizations, neither one is true in reality. It is indisputable that recently, interest in history has increased; this is, of course, manifested in many ways. No doubt the demand for adventure films represents a different level than the demand for--let us say--memoirs. The popularity of serials, documentary volumes, or even the journal /Historia/ which fulfills the task of promoting historical knowledge, truly signifies a rise in the level of mass demand. I feel that there is no difficulty with attitude--and ultimately, this is the basis for the formation of historical awareness. We have long since discarded the unscientific practice popular

in the 1950's which limited the course of our 1000 year-old history to a few events selected from the system of interrelationships. Actually, this sort of restriction was unscientific, anti-marxist and, in truth, numbing.

If we are not familiar with the Reformation, it is hardly possible for us to comprehend 1848 to its full extent, and we may only perceive the tragedy of Vilagos if we see the fateful defeat in the sequence of later events. In the past few years, we have "rehabilitated" the founder of our state, King /Stephen/; we have rediscovered the Hungarian Middle Ages; we have acknowledged the merit of the great reformers; and we have made our alienated revolutionary heroes more human. Strictly speaking, we have repossessed that which belongs to us: our history in its entirety.

Of course, let us not delude ourselves: education and culture--and more than one educational or literary work--still reflect the confusion of attitudes; a "see-saw attitude" still exists on this level as we strive to "heroicize" certain heroes in such a way that, in exchange, we "deheroicize" others who were extolled until now. And an enormous segment of the population of this country is virtually inaccessible from the viewpoint of the formation of historical consciousness. Confusion on the formative level is caused on the one hand, by the fact that the rehabilitation of deserving "kings, princes and counts" occasionally reveals the belief according to which now all historical figures must be rehabilitated; on the other hand, a more shaded appraisal of certain individuals--for example, earlier civil politicians--could be followed by the suspicion that we are preparing to rehabilitate, let us say, the Horthy era...That these sorts of experiments could occur only reinforces the suspicions; however, this is unavoidable--unavoidable but refutable.

In this respect, the writing of memoirs is a somewhat dangerous literary form. It is useful because it is rather suitable for arousing interest in history; I might also add that viewed in a certain healthy sense, it satisfies the hunger for gossip. But it also requires objective and attitudinal background from the readers, since it is not possible for the author of even the most scrupulously written memoir to be free of bias: the author tries to justify and apologize for himself and transmits either subjective sympathy or antipathy to his readers.

[Question] /Many profess that in addition to the daily cares and problems filling our lives, it is superfluous to deal with the past. Might a "dual mentality" exist --one which values and analyzes our historical past, and another which deals exclusively with the present?/

[Answer] We are far from having attained a generally high standard of historical knowledge, and I doubt whether this would ever be possible. But obviously, the goal is not to make an amateur historian out of every Hungarian citizen. It is absurd to expect the young and old of our nation to constantly deal with historical questions even as a hobby or diversion. There was, is and will be a fairly sizable contingent which is neutral towards matters of history. There is also a distorted attitude whose representatives view history as "worthless", "a dead body of knowledge", and would exclude it even from the realm of contemporary general education. The opposing view is that which would pour facts, data and the resulting conclusions of history into heads through a funnel, because it views the strengthening of historical knowledge as a wonder drug which directly brings the creative energies of society into

motion, and which could serve as a cure for our troubles and anxieties. Let us note that one does not work better the next day because of becoming acquainted with the diplomatic antecedents of the Bosnian occupation the night before, nor does one stop drinking because of seeing a gripping documentary about the Battle of Mohacs. There are no such direct effects--but the formation of historical awareness does indeed have an effect. Only, we should not confuse historical knowledge with historical awareness. "Awareness" is not blindly memorized, dead material; it is simultaneously more and less than this. The French historian Michelet said, "He who knows only the present does not know the present."

A person who has lost his memory and from whose awareness the past has been erased along with all associated emotions and experiences will obviously become an emotional cripple. We know that every human community--family, class, nation, humanity--is a living organism, thus the collective "amnesia", the mutilation of historical awareness would result in similar consequences. A society which "loses its memory"--either collectively or individually--loses its links not only with the past, but also with the present and the future, which stem from the past. The accumulated treasury of historical experiences becomes inaccessible; concepts such as "homeland", "people" and "humanity" become meaningless. This sort of community is only a pseudo-community which is loosely held together by individual--only individual and not communal--interests and intricate relationships. The motherland is not longer binding; the principle of "the land in which my life is better is my home" takes effect; the concept of patriotism becomes meaningless; at best, internationalism is replaced by cosmopolitanism.

As I said, awareness is not entirely identical to factual knowledge, although it is one of its components. But the professor of history does not necessarily have historical awareness. A great mass of people who may have historical awareness--because it happens to be their social awareness--may apparently be apathetic to historical matters. I say apparently, because the "material" forming awareness seeps into society through capillaries virtually unnoticed, all the way down into the "deepest" levels.

[Question] /Among the youth, the concept of patriotism is limited to totally banal manifestations in many instances. Only rarely is the youth able to read about the emotions, intellectual world, and patriotism of the participants in historical events, revolutionary movements and wars of independence in the pages of school history textbooks; there, only the facts are assembled. Do you see a way out of this situation, and if so, how do you perceive it?/

[Answer] The young are hardly responsible for the banalities. They use the platitudes because this is what they hear in school and at halfheartedly organized ceremonies; they read them in poorly written articles and reminiscences. Of course, they use them, since they believe--and often with justification--that this is what is also expected of them. Patriotism is not dependent on words; I believe that its essence would be hard to verbalize. Certainly, it does not help if we force them to memorize the factual material of history, nor does it help if we make them "analyze" the patriotic sentiments of /Lajos Kossuth/ or /Aurel Stromfeld/. This is like the terrible literature classes where a poem of /Sandor Petofi/ or /Attila Jozsef/ is dissected to the bone; as a result, the student will hate it forever--at best, he

will hate the poem in question, and not poetry as a whole! Of course, I cannot provide formulas. At most, I could say that clear reasoning, the representation of historical heroes as men of flesh and blood, cooperative thought and the arousal of the endless curiosity of the young and its intelligent satisfaction are what mean more than all else.

[Question] /The youth who enter the armed forces arrive at one of the greatest training schools; the formation of their awareness focuses on two main points: patriotism and internationalism. In your opinion, how is this "intellectual investment" returned?/

[Answer] The defense of the country is truly a civic duty. And this obligation may be fulfilled in numerous ways: even halfheartedly and under compulsion. Those from whom the communal spirit and the feeling of responsibility for the whole are lacking will obviously fulfill their duties in this way. But this may also be perceived in a different way.

Of course, I must again say that we should not delude ourselves. No matter how much he knows about the great predecessors, about the heroes of 1848 or 1919 or about Hungarian internationalists, the private who did not choose the army as his profession will continue to mark the tape measure hidden in his tunic and count the days left before his discharge. The "intellectual investment" is not returned in such a way that every conscripted soldier becomes a "happy soldier", but rather by perceiving his service as a communal order and not just as a compulsory responsibility--in service to the "continuous historical present" alive in his father, in him and in his future descendents. Besides this, the army is obviously also a training institution; in addition, it is a training institution where the youth of those classes, which I previously mentioned as still inaccessible today, become accessible to the forces which form awareness.

[Question] /As a writer, you have already done much in the interests of making history more accessible to us through literary means. You also spoke of your particular "work-related concerns" at last year's scholarly conference in Eger. Now as editor-in-chief of KORTARS, how do you propose to work for this same cause?/

[Answer] There are fairly many opportunities for this at a literary journal--for example, by also publishing historical studies and perhaps memoirs in addition to literature, which is of primary importance. Just in the past few days, the deputy editor-in-chief of our sister journal in Moscow, /Novy Mir/, visited our editorial offices. From the discussion, it became apparent that an increased interest in history may also be observed in readers in the Soviet Union. For this reason, a new memoir column was begun, and the number of subscriptions skyrocketed. I think that this is also something we should consider.

9956
2500/201

REVIEW FINDS BOOK HISTORICALLY MYOPIC, 'SELF-MUTILATING'

Budapest MOZGO VILAG in Hungarian No 6, 1983 pp 65-67

[Article by Gabor Szigethy: "Reworking the Past"]

[Text] According to the definition of the Concise Hungarian Explaining Dictionary: "Self mutilation--1. Law also: the crime of someone crippling himself for the purpose of avoiding military service. 2. Zoo. The phenomenon of certain animals allowing some parts of their bodies to break off if caught in a desparate situation, (for example, the lizard, its tail)."

I am reading a hefty book. Its author is Gyula Antalffy, and its title is: Drawings of Hungarian Cities in the Reform Era. Managing publisher: Dr Istvan Arky. Managing editor: Mrs Simo nee Eva Avarossy. Consultant readers: Dr Tibor Bellon, Dr Imre Danko, Dr Jozsef Kanyar, Peter Laszlo, De Sandor Mithay, Agnes Sagvari, Dr Laszlo Szita, Dr Otto Trogmayer, Dr Laszlo Veres.

To bring back magically the times of the past; to recall the lives of the Hungarian cities in the reform era; to see before us as the little girls, all dressed up with pink and blue ribbons, walk to church, [or] their whispering excitement before the balls, and to sense in our noses the aroma of fine coffees with whipped cream and potcakes; to let the numbness hurt in our guts caused by the road wagons jarring on the bad roads, and let the panoramas of the old Hungarian cities tower in our imaginations, the smoke of the steam locomotives, the twisting-turning of the roads, the glitter of the windows of palaces; to hear the squeaking of the green shutters, the noise of the water splashed on geraniums on the windowsill, the din of the confusion at the fairs, to suffer the sharp pain in our sides as if, in passing, a curly-haired fop's arrogant elbow jarred us, and to smile inwardly if we feel: a Biedermeyer dame with curly locks and a come-hither look is coming towards us, perhaps to invite us to the ice cream parlor for a pleasant and innocent chat.

Gyula Antalffy offers his services as guide: he is inviting us to the Hungarian landscapes of the reform era--to travel into the past.

Those who accept his offer and, using his services, wanders in the reform-era's Hungarian cities, will soon get lost. Because Gyula Antalffy accumulated a tremendous amount of data and quotes on a tremendous number of paper slips, then piled the large amount of knowledge he has as his own as the result of

decades of industrious work, into a haystack without screening and a well-thought-out organizing principle. He thinks--as he clearly defines this in his introduction--that in view of the fact that he wrote a book not as a scientific project but for reading entertainment, he does not have to be critical of his sources, he does not have to consider the historical development viewpoints, and he even leaves it up to the readers whether or not they want to rely on the trustworthiness of his quotes as the author. In this way, then, without selection he lists all kinds of reform era authors, newspaper articles, reports, letters from readers, memoirs, works of art, poor quality works, flattering briefs, satires--texts, and all this as truth from the reform era. More accurately: as the truth of the reform era, the everyday intelligence of our city life of the last century.

His naivety is misleading and irksome; the result: a distorted picture.

Because in the reform era, too, there were a good number of liar newspaper reporters who always kept their selfish interests in mind--those who wrote something else than what they experienced and knew; and there were some rememberers [sic] with weakened memories--who threw together any old thing in the name of history and truth; there were some stupid people--whose printed chatter is not wisdom, but only dumb obstinacy; there were some ungifted writers--who wrote, but did not see what they were looking at. Antalffy believes everything from everybody, and since he does not check on the authors of the quotations, in his book he dishes up the contents of random newspaper clippings as the reality of the reform era, as "the word of the era." And to boot, selected without any evaluating sense of quality, since it is completely immaterial to him whether Sandor Petofi [great mid-19th century poet] or Ferko Csipcsirip [Nitwit Frankie] speaks about an event. Everybody is the word of the era. Thus the essential and the immaterial are completely blended in his book, and often the essential is the very thing that disappears. For example, he quotes one sentence from Tullio Dandolo's travel descriptions: "As if Pest had its palaces lined up along the Danube's shore for the sole purpose of providing a pretty reception for the arriving foreigner." A beautiful and disinterested sentence. And especially if we know that in his travel book published in 1841 Dandolo committed several pages to the city building and urban development ideas of Istvan Szechenyi, and provided a detailed report about his discussions with the count. They were usually discussing the contemporary urban picture of Pest-Buda and the most important topic defining urban life, the permanent Danube bridge under construction. But Gyula Antalffy keeps quiet about all this.

The remainder fabricates a strange idyl from the many inessentials: charming and carefree, monotonous reform-era pictures of Hungarian cities develop from his descriptions, papier-mache cities, a commonplace reform era.

Were Gyula Antalffy truly familiar with the city life of Hungary's reform era, and with the mentality of our country in that era, in no way would he have left out from his city drawings Komarom, the trading city on the water with busy traffic, or Balatonfured with its bubbling cultural and social life, the most significant bathing city of the era; or Pozsony [Bratislava], the center of political life, seat of the Hungarian national assembly.

I am looking at the book's contents page. Hungarian city drawings from the reform era: Sprobn, Koszeg, Szombathely, Egerszeg [Zalaegerszeg], Kanizsa [Nagykanizsa], Kaposvar, Pecs, Szekszard, Baja, Szekefehervar, Veszprem, Papa, Esztergom, Vac, Pest-Buda [Budapest], Cegled, Koros, Kecskemet, Szeged, Vasarhely [Hodmezovasarhely], Mako, Gyula, Jaszbereny, Karcag, Felegyhaza, Debrecen, Eger, Miskolc, from Over [Mosonmagyarovar] to Patak [Sarospatak], (Gyongyos, Nyiregyhaza).

This many. Only this many.

Could it be that Gyula Antalffy and the book's nine honorable lecturers, its managing editor and managing publisher did not know how large Hungary was in the reform era? I find it difficult to believe that the honorable author and those cooperating in publishing the book never heard that in Hungary's history the most significant cities, the most meaningful ones in its political and social life, the most definitive ones in its civilian growth, the most valuable ones in its intellectual and cultural life, and the most important ones in its industrial and commercial development, were: Pozsony, Kassa, Szatmar, Arad, Temesvar, Nagyvarad, Kolozsvar, Marosvasarhely, Gyulafehervar, Besztercebanya, Eperjes, etc. Let me not continue!

Are these not reform-era Hungarian cities?

I ask the hon. author, his hon. lecturers, his managing editor, and his managing publisher: how did they have the courage to publish a book with the title of Drawings of Hungarian Cities in the Reform Era if they are so uninformed in the reform era's Hungarian history? If they know so frightfully little about what life was like a century and a half ago in our country? Such ignorance is a shame even in the case of an elementary school student, even though elementary school students do not author, lecture on, edit, and publish 439-page books about reform-era Hungarian cities.

Unfortunately, I cannot pacify myself even for a moment by thinking that the author, the lecturers, the editor, and the publisher are merely ignorant in this case. Even though as a fact, even this is disheartening. Unfortunately the author, the lecturer, the editor and the publisher are not ignorant. Because the hon. author divulges it in his foreword; he knows that in his book he is not discussing the significant Hungarian cities of the reform era. He says: "And yet, in our book at this time we will not cross the present day borders, for which not the least of the reasons is to be able to ensure more room for the cities which remain within the country's present borders."

A surprising turn of events. That is, the hon. author and the publisher intentionally forgot practically all of the more significant ones of the reform era's Hungarian cities, so that they could write about some small cities--pleasant ones, but insignificant in the reform era--such as Egerszeg or Nagykoros. The tone of the foreword indicates that they are proud of this excellent idea! Reader, be grateful that your self-appointed tour guides are leading you into the castrated Hungarian past!

An original idea: with one fell swoop, throw half of Hungary out the window!

By way of analogy, a Hungarian literary history could be written from which the volume published in Pozsony [Bratislava] by Mihaly Csokonai Vitez, the Dietai Magyar Muzsa [The National Assembly's Hungarian Muse] would be left out, saying: it is part of Bratislava's literature; Kazinczy's works entitled "Letters From Transylvania" could be published in the World Travellers Series, and--God forbid--we could consider Sandor Boloni Farkas to be a Romanian Hungarian writer; and we could also forget the youth and the first works of Zsigmond Kemeny out of our reform-era literary history because Zsigmond Kemeny lived in Kolozsvar, what do we have to do with him?

We could also omit the political activity of Miklos Wesselenyi from the Hungarian history, not to mention Kolozsvar's Hungarian theatre, Gabor Dobrenitei, and the Hungarian Museum in Transylvania, and we could consider Ferenc Kolcsey to be a Slovakian and Romanian politician, and as long as we have started it, let's not be stingy and let's throw Janos Apaczai Csere, Ferenc Papai Pariz, Peter Pazmany, Istvan Bocskai, and Gabor Bethlen out of the Hungarian ship. Those who would look, could find more!

And for the sake of simplicity, considering the fact that until 1848 the Hungarian national assemblies met in Pozsony, which according to the hon. author and his publisher was not a reform-era Hungarian city, let's just consider that there was no Hungarian national assembly. One less headache!

Based on the Constitution of the Hungarian People's Republic, physical self-mutilation is punishable by law.

And the intellectual one?

8584

CSO: 2500/325

BRIEFS

VATICAN VISIT--Archbishop Luigi Poggi, extraordinary apostolic nuncio of the Vatican, accompanied by Dr Laszlo Cardinal Lekai, Archbishop of Esztergom, met on 11 May with Bishop Dr Tibor Bartha, president of the Council of the Reformed Church of Hungary and the Ecumenical Council of Hungarian Churches. In the brotherly atmosphere of the meeting, they discussed the ecumenical contact of the churches, their services in this world. They expressed their appreciation of the deepening fellowship of Hungarian churches and denominations, and further expressed hope that the worldwide strengthening of the church fellowship would help to unite and heal the divided human community. [Text] [Budapest REFORMATUSOK LAPJA in Hungarian 22 May 83 p 1] 9890

CSO: 2500/324

ARMY DAILY COMMENTS ON WALESA'S REMARKS, WEALTH

AU291052 Warsaw ZOLNIERZ WOLNOSCI in Polish 27 Jun 83 p 2

[Col W. Zielinski commentary: "In the Old Style of Walesa...."]

[Text] In an interview with a correspondent from the West German FRANKFURTER PRESSE, L. Walesa was asked about the economic troubles caused by Solidarity. He replied: "The economy was functioning better in our day. People who are demonstrating today because they are dissatisfied used to work very efficiently in our day.

Walesa is either counting on collective amnesia by all Poles, or he is an all-time hypocrite. Besides, it is not out of the question that he is praising "his own ties" because of his own, personal gains. If he is, then one can agree with him. Thanks to Solidarity, Walesa has become a very rich person in less than a year and a half. This is evidenced by, among other things, foreign currency accounts, cars, and also several servants such as a chauffeur, a secretary, and bodyguards. To this personnel one has to add advisers and several Western reporters.

It seems that it is worth considering why it is that no other trade union leader in the West, whether Christian, leftwing, or centrist, has enjoyed such a "linking" by capitalist leaders and politicians as Walesa, neither in the recent nor in the distant past. He is liked by the same people who are combating the trade unions in their own countries! Also, no other representative of the trade union movement is adored and praised so much by subversive radio stations such as Radio Free Europe and the Voice of America.

Tangible evidence of this "liking" for Walesa are the distinctions and dollar prizes which fall on Walesa like manna from heaven. These amount to tens of thousands of dollars and West German marks.

It is very odd that with such tangible proof of sympathy toward the "leader" by, as Radio Free Europe has estimated, 10 million Polish workers, these same gift bearers and their political overlords are using any means to harm these workers and lessen their standard of living. The economic restrictions announced by President Reagan and his Western satellites are one example of this. At the same time, subversive radio stations, which are government agencies of

Washington, Paris, London, and Bonn, are telling Poles that the deterioration in the standard of living lies in the interests of the workers, and that the Polish authorities will carry the blame for it. The purpose of these subversive and propaganda actions is clear and transparent.

I do not rule out that there are those who praise "those days" together with Walesa. In those days, we could rest, sunbathe on the roof, eat lunch, often in luxurious restaurants, and in addition one received normal pay, just like at work. Some students also praise "those days," remembering wonderful picnics with vocal artists and musicians performing, and sometimes even professional singers and actors. And what about the farmers, do they not reminisce about the days when they could afford "vacations" in offices in the fall and winter, or in branch offices of the United Peasant Party? The only thing is that in "Mr Walesa's time," the economy was on the verge of collapse and there was not much to go before it collapsed completely. I suggest to those who have any doubts that they look at the "Resolution" contained in the Congress Documents (from Gdansk in 1981) on page 94, where the following was probably written without Walesa's knowledge: "...Adopting a draft which does not conform to the will of the work forces causes a growth in tension and makes it difficult to emerge from the economic ruin...."

It seems that it would be irresponsible of me to polemicize with the statement Walesa made to the FRANKFURTER PRESSE at the end of May this year that "people who are demonstrating so often today because they are dissatisfied used to work very efficiently in our day."

Although Walesa revealed his dislike of reading to the Italian journalist O. Fallaci, he probably did read the resolutions of the movement's authorities, as well as what his closest colleagues and advisers had written. Let us consider the following KOR Information Bulletin No 6 from 1980, in which Adam Michnik wrote: "Burning committees (party committees--ZOLNIERZ WOLNOSCI clarification) will illuminate the real shape of the picture of society...." Perhaps the interview given by Maria Plonska to Danish TV on 8 September 1980 is unknown? In case it is, I present a fragment of it: "Creating further bodies means creating a separate, independent structure. It means quite simply an exchange...this will be a so-called chain reaction whereby further spheres of activity are wrenched out of the hands of the totalitarian authorities."

One has to admit that during the year and a half, some people in "those times" did indeed work, although this cannot be regarded as socially useful work, which can be proved. Oh, how they worked! Nevertheless, they did not achieve the goal they were aiming at. Luckily!

CSO: 2600/1109

OFFICIAL INTERVIEWED ON TRANSFER OF UNION ASSETS

AU301546 [Editorial Report] Warsaw ZYCIE WARSZAWY in Polish on 27 June on page 4 carries a 2,400-word interview by Romana Kalecka with Piotr Karpiuk, chairman of the Commission for the Administration of Trade Union Assets, entitled "The Assets of the Former Trade Unions," concerning the extent of the wealth of the former trade unions in Poland, especially that of the Solidarity Trade Union, and the way in which these assets are being transferred to the new unions. The interviewee stressed that the commission has had to deal with "bad documentation" and cites cases of "misappropriation" of union funds. He gives an example that "the difference between the amount of cash withdrawn to pay striking workers at the Poldres plant and the amount actually paid out has been Z135,000." Piotr Karpiuk then goes on to say that "there was often a lack of receipts for equipment which was loaned out and of the 75 typewriters which were, for example, the property of the Mazowsze [Warsaw] chapter, 13 of which were IBM's, only 4 are left, manual of course." This is just one of the discrepancies P. Karpiuk mentions with reference to the Mazowsze chapter in particular.

He then continues to express his criticism of the fact that Solidarity did not leave any documented evidence of its assets, "aside from what was in the SOLIDARNOSC weekly," and that "it did not observe any financial regulations or principles of rational, economical management."

Also, the interviewee asserts that "in Slupsk, for example, a farmer was given a loan from union funds to buy a tractor," and that union funds were also "an unlimited source of income sometimes for whole families who worked for the union on a part-time commission basis."

"We discovered that striking workers had been taking money from union funds which were never repaid, as in the case of the strike at Warsaw University, where over 1 million went to strikers," P. Karpiuk said. In some cases part of these loans disappeared completely and "the commission will therefore demand the return of this money or will ask for it to be squared in the accounts. However, if this fails, we cannot rule out court proceedings since we are working on the principle that no one should grow rich by appropriating union funds."

Romana Kalecka, the interviewer, then says that reports of such "drastic" incidents are often believed to be attempts to "blacken the reputations of those who cannot publicly reply to these accusations," but P. Karpiuk, tells

her that these facts are fully documented, agrees that these incidents are thought to be slanderous by some and provides the following explanation: "It is true that some people, especially a certain radio station which sees everything in either black or white, is accusing the commission of being biased," he says.

P. Karpiuk then goes on to say that of the 37 chapters, the National Commission as well as the 192 local units of Solidarity that were taken over, "the value of Solidarity's fixed assets has been estimated at about Z320 million, of which Z166 million amounts to the value of a building which was donated to Solidarity in one of the voivodships. About 40 percent of these assets are made up of vehicles for transportation and communications equipment, over 30 percent is printing equipment and typewriters, and about 15 percent is comprised of other technical equipment. "The structure of such assets," the interviewee says, "clearly shows the nature and purpose of this movement and it demands no further comment."

Moreover, P. Karpiuk says that there is almost Z609 million and about \$54,000 in Solidarity bank accounts although, citing once more the Mazowsze chapter, P. Karpiuk says there is a \$6,000 deficit there alone. He also says that more or less a third of the funds in these accounts will have to go toward settling Solidarity's debts. "We do not know on the other hand how much we will be able to extract from those owing debts to Solidarity on the evidence of receipts for loans and security benefits."

P. Karpiuk then says that "it would appear from documents that apart from a group of activists in the employ of Solidarity, Rural Solidarity did not exist, since we established that there was no income from members' subscriptions but there were large debts."

When asked how former trade union assets would be fairly distributed among the new unions, Piotr Karpiuk replies that he believes a proportional distribution would be more just, "in relation to the number of workers in plants where trade unions are active in various national organizations throughout Poland. This would be a fairer criterion than if we were to distribute the assets according to the size of trade union organizations, especially since a greater part of these assets serve, after all, the workers at large," the interviewee concludes.

CSO: 2600/1106

RETURN TO SCIENTIFIC MARXISM-LENINISM URGED

Warsaw NOWE DROGI in Polish No 4, Apr 83 pp 113-124

[Article by Wlodzimierz Lebedzinski: "Marxism and the Building of Socialism"]

[Text] The deep sociopolitical, economic and moral crisis which revealed itself drastically during the memorable events of July-August 1980 and later deepened and expanded, encompassing nearly all aspects of our life, did not emerge unexpectedly like Aphrodite from sea foam, but had at its basis numerous complex sources and mechanisms both internal and external. Some of them had been formed in previous decades; others on the other hand were chiefly a product of the second half of the 1970's, the period of gradual but continual departure from the basic principles of scientific socialism in theory and practice.

Enough has been written about them so far. Beside genuine diagnoses, however, many mystifications, distortions, and even calumnies obviously intended to debase socialism and marxism-leninism in general, have accumulated. Nonetheless, and perhaps all the more so, the problem of the whys of the lapses, errors and obvious distortions of the past, eagerly exploited by anticommunist opposition for the preparation and carrying out of a counterrevolutionary coup, still requires extensive studies in two basic but closely related and mutually dependent planes: objective and subjective. The point of the first one would be chiefly to detect the sources and mechanisms of the transformation of non-antagonistic conflicts into antagonistic processes in the building of socialism; this would allow us to construct methods and instruments for overcoming them dialectically before they start to generate social conflicts. In the second one the point would be to become more closely acquainted with the subjective deviations in people's consciousness and attitudes in the process of building socialism and thus also with the possibilities and limits of influencing by means of subjective factors the objective sphere of the lives of individuals, groups, social strata and classes. I shall not make a major mistake by stating that our knowledge in this regard still leaves much to be desired.

Among the numerous causes of our weaknesses I shall expose here only one which, however, in my opinion is extremely important and maybe even fundamental: it is the deficient knowledge of authentic marxism-leninism both within and outside of the party. In place of critical marxism-leninism, a simplified and sometimes even vulgarized, pragmatic version of "bureaucratic marxism," mostly

reduced to an assemblage of current political statements, began to form itself in the past. Although marxist vocabulary was retained, valid scientific content was eradicated from it. For example, dialectic, the methodological tool of marxism, has been eliminated almost completely. That is why today we have nearly no works in that area. Nevertheless we know that dialectic is the most creative and revolutionary part of marxism (V. I. Lenin: "Works," v. 19, p 577). Perhaps for this reason it did not fit into the propaganda of success. The whole ideological apparatus of marxism-leninism met a similar fate.

"Bureaucratic marxism," or rather pseudomarxism, was disseminated by the mass media. Consequently it quickly rooted itself in the consciousness of large masses of society, party members above all. It was to perform the function of the party's new ideology. The apologetic version of "bureaucratic marxism" was identified in social awareness with marxism-leninism in general. Deceptive in its contents, ignoring essential problems of human life, it was needed by the pragmatic-technocratic and bureaucratic elite for the acceptance of their practices.

"Bureaucratic marxism" could not however effectively perform the ideological function of the party and the working class as a whole for it did not reflect social reality. It was not possible to draw sensible practical directives from it. It was helpless in forecasting new phenomena and processes. At the same time authentic marxism-leninism was being increasingly pushed to the margin of social life. At the most it became subject to narrow academic study. As a result, the party was facing a nearly complete ideological disarmament.

Numerous discussions, publications and party documents with which we have dealt since August 1980 irrefutably prove that in many cases they have not been based on methodological foundations of marxism-leninism. Rather they have been based on superficial observations, intuition and results of commonsensical reflections. At times even alien ideological and political premises lay at their basis. One could rarely see a concrete historical, class and dialectical analysis of the social, political and economic processes and events taking place in the country.

I will make use of a few examples:

In the Gdansk materials for the PZPR Extraordinary Ninth Congress we read: "From the marxist ideal of planning and social self-realization of producers' unions it was inferred on the basis of construction and joining together many different views that the ideal system is a monocentric system with nationalized means of production and ultracentralist organization. Instead of a socialism based on a free association of producers, state socialism was formed." (GLOS WYBRZEZA, 23, 24, 25 January 1981). The text contained many more similar and even more drastic and not less muddled formulations.

On 31 August 1981, when the situation in the country was sufficiently well-known and the intentions of opposition's forces became clear, T. Fiszbach, the then first secretary of the KW PZPR in Gdansk stated: "The Gdansk agreement requires however taking a new historical look, although now it is most

difficult to do so. I think that by signing the agreement Poles have given themselves an opportunity and did not waste one. It continues to exist. The future will show it--and I believe deeply that this opportunity will be used. If so, history will consider the document of 31 August 1980 as one of Poland's best political investments between the beginning of the 18th and end of the 20th century" (GLOS WYBRZEZA, 31 August 1981). Not a trace of class or concrete historical analysis; a lot of megalomania instead. No wonder that as a result of such evaluations various delusions were born, changed and dissolved while the country continued to plunge into unfathomable abyss.

In the course of many stormy months marxism-leninism did not play the role it deserved. Its simplified version turned out to be quite helpless. It happened for three basic reasons: 1) Marxism-leninism found itself under concentrated attacks of opportunistic, revisionist, social democratic, trotskyist, petit bourgeois and openly anticommunist ideologists. By fair means or foul, breaking the elementary principles of intellectual and moral honesty, the adversary debased even the most obvious and scientifically founded marxist formulations. It is characteristic that our ideological adversaries imputed the thought of their recipients that supposedly apart from the simplified version of marxism no other existed. As a result it was easy to argue that theoretical principles of marxism-leninism did not need to be at the foundations of the building of socialism. 2) Marxism-leninism did not find a sufficiently strong and appropriately broad defense on the side of communists, who to a large degree became lost in the whirl of events or else found themselves under the pressure of massed enemy attack. The attack was facilitated by the fact that over the years even flagrant errors in the building of socialism were repeatedly shielded with marxist phraseology. 3) Marxism-leninism was unable to offer such explanations for the sources of existing conflicts and proposals for their solutions which would find a broad social acceptance as an antidote for the demagoguery of antisocialist opposition.

The building of socialism requires not only profound economic, political and social changes but also, and perhaps above all, consciousness and psychological changes, whereas not infrequently it was assumed that these would take place automatically, following economic changes. It is worth recalling here the words of A. Karkoszka spoken during the deliberations of the sociopolitical aktiv at the beginning of 1971 in Gdansk: "We have occupied ourselves with ideology enough. Now it is time to take up practical problems." Without ideology, of course. It is clear that A. Karkoszka at the same time expressed the way of thinking of the then party leadership. As a result man's conscious-psychological sphere has been neglected. This has been used by nonmarxist ideologists. Our errors in sociopolitical and economic work for years have helped the infiltration of views and attitudes which are alien to us. As a consequence, immature social consciousness and difficulties of daily living became a ground on which an anticommunist opposition formed itself, developed and gained relatively broad support.

For a long time and with much freedom, numerous nonmarxist and openly anti-communist ideological doctrines flowed into the country. As the sociopolitical and economic situation worsened, they found an increasingly greater reception in various social circles. At the same time while the party's

ideological work was becoming more superficial and illusory, the possibilities for action of our domestic anticommunist opposition were gradually increasing. In the name of moral and political unity, not only a critical viewing of reality, but also a polemic with the internal and external adversary were thwarted. Various ideas formulated in the so-called Frankfurt School were not being analyzed on a large scale. They turned up in post-August discussions as oppositional versus marxism-leninism, trotskyist, social democratic, anarchosyndicalist and other theoretical concepts were hardly being dealt with. These were later used in the struggle against marxism and scientific socialism. Different forms of former and contemporary socialism basically remained outside the sphere of marxist interests. More examples of similar neglect can be quoted.

In marxist scientific milieus an atmosphere of avoiding discussion and polemics was being created gradually yet inexorably. Probably for this reason the views of S. Kurowski, who for years had been trying to substantiate that marxism-leninism contains insurmountable errors, were practically not criticized at all. These errors, in his opinion, created conditions for the failures in building socialism. Therefore, he concluded that marxism and socialism must be rejected and replaced with free market capitalism. Similar conceptions were conjectured by L. Kolakowski and L. Nowak. The titles of numerous lectures and uncensored publications appearing in the post-August period speak for themselves: "On the Necessity of Phasing Out Socialism," "Marxism as a False Consciousness," etc. It must be admitted that L. Nowak's lectures usually attracted a large number of listeners, particularly among university students. This testified, however, not so much to the lecturer's revelatory thought--particularly as he simplified and even vulgarized several marxist-leninist ideas, but rather to the minimal marxist knowledge of his listeners (see for example J. Tittenbrun: "On Nonmarxist Historical Materialism," Poznan 1982).

One can say therefore that at the time of the most difficult test, marxism did not play a major role in Poland because it had much earlier been effectively pacified. The blame for this state of things lies clearly with the party leadership of the time and with the way it developed or rather hampered ideological-educational activity.

There however is another, perhaps more fundamental reason for the weakness of marxism-leninism in our country. It so happened that for many years it remained under the potent influence of the leadership elite of the time. As a result the functions of marxism were reduced to consolidating particular political decisions. This manipulation led as a consequence to a decline in the cognitive and critical-methodological functions of marxism. Instead of basing various political decisions on the cognitive data of marxist theory these decisions themselves were elevated to the rank of a theory, defined as marxism-leninism. Gradual obliteration of the demarcation line between marxism as science and current, often transitory political conceptions necessarily led to an elimination of marxism. One could easily cite a good number of examples when ideas born in the heads of politicians at plenary meetings of the central leadership were hastily introduced into the ground of marxism. Characteristic and very symptomatic in this respect were the concepts of

developed socialist society in Poland, the moral and political unity of the nation, the state as the highest good, etc. In these conditions marxism as science indeed became superfluous. What remained as a decorative facade, superficial and banal, which could neither generate scientifically valid cognitive results nor satisfy social expectations and needs.

The fact is that nothing can replace the cognitive and practical functions of creative marxism in the process of building socialism; all nonsocialist social systems however formed themselves and developed spontaneously.

The building of socialism is a theory created by the classics of marxism-leninism. Socialism is therefore a system theoretically planned. Karl Marx discovered, as we know, the fundamental laws of social development. On their basis he justified the necessity for a revolutionary transition from capitalism to socialism. He formulated the major material, intellectual and moral premises of socialist revolution and set forth the general principles of socialism and communism. He also explained and developed the dialectical method for analyzing various social processes and phenomena. He could not, however create a detailed theory of the functioning of a socialist system since the objective conditions for it had not matured yet.

The enormous contribution of Vladimir Lenin to the theory of marxism consisted, on the other hand, of a creative application of K. Marx's ideas to concrete Russian conditions. He elaborated a number of general and specific conclusions of universal and transitory value. Lenin's particular merit lies however in the fact that in the concrete situation of the Russia of his time he prepared and carried out a victorious socialist revolution. Hence comes a natural need for the creative development of marxism-leninism in the concrete conditions of building socialism in particular countries.

The changing external, internal and international conditions for building socialism first in one and then in many countries require, therefore, intensive cognitive studies. Particularly since after World War II, when a number of countries of diverse social, economic, psychological and national conditions and characterized by different traditions, experiences, etc., embarked on the road to socialism, the realization of the general ideas of scientific socialism requires their detailed concretization. The latter however is not possible without specific scientific studies. This state of things is not identical in the various socialist countries, of course. In our case, we experience evident weaknesses.

We finally found ourselves in a situation at least partially characteristic of spontaneous development. The so-called open economic plans were a proof of this. The building of socialism therefore began to be pushed with the aid of sometimes contradictory political decisions. The changibility of these decisions, dependent on the outlook and skills of the leadership team and the voluntarism of particular individuals, by necessity implied continuous swings in social development, particularly if we also consider that political decisions were often undertaken "ad hoc," without a broad and deep theoretical support. At the First All-National Ideological and Theoretical Party Conference, Wojciech Jaruzelski asked the following questions: "Why did a part

of the theoretical party base so easily succumb to apologetic temptations? Why does the transmission between theory and practice, science and life and the continuous struggle not function properly?" And here is his response: "Today it is clear that the political practice of the past period to a large degree promoted this state of things. First, certain assumptions were accepted and decisions made, and only later were they underpinned with a theoretical justification."

"There was no need for a concrete analysis of contradictions in society and a method of solving them as a driving force of development.

"From party life such concepts as criticism and self-criticism disappeared." (First All-National Ideological and Theoretical Party Conference, Warsaw 1982, p 11)

In this light the continually increasing domination of pragmatism and technocracy in our social life becomes understandable. A lesser or greater destabilization of human existence, manifesting itself in periodic social conflicts has consequently resulted from this domination.

It becomes clear from the above that the prospect of building socialism remains directly related to, beside other internal and external conditions, our knowledge and ability of applying it to practical activity. Thus there is a need for intense studies of the functioning of the socialist system in concrete conditions of each individual country.

We have barred the way in Poland to counterrevolution by using the instrument of force. This was a historical necessity. When the enemy rejected the force of the argument, the only argument left to us was force. Yet force is a short-term and untrustworthy argument. It must be replaced by the argument of the socialist system's superiority over other social systems. This will happen when socialism begins to develop according to natural, socialist laws and social mechanisms and not on the basis of somebody's whim. For this however a solid and thorough knowledge and ability to transform it into the practice of daily life are needed. Marxism however is still accompanied by two basic deviations: dogmatism and revisionism. They only seemingly are contradictory. As a matter of fact, they both reassess the thorough nature of marxism. The first supposedly defends orthodox marxism and fights against revisionist trends but from the positions of stagnation and unalterability of any theoretical theses. The second unjustifiably eliminates the basic valid formulations from marxism-leninism, replacing them with new ones that supposedly develop marxism while in fact they distort it or even eliminate it. Both revisionism and dogmatism undermine the authority of marxism, which as any science is subject to dialectical laws of changeability, while dogmatism and revisionism, to use Lenin's expression, are a foreign growth on the live flesh of marxism-leninism. Therefore they must be fought in equal measure and with full determination, for they bring irreparable theoretical and above all practical damage.

I would advise however to distinguish between dogmatism and revisionism in marxist-leninist science and in politics. I have written about in a series

of articles entitled: "Marxism Versus Philosophical Revisionism"
(POLITYKA 1969, No 3, 5, 8)

Taking off from methodological directions of marxism, communists ought to analyze independently the reality in which they live and act. They cannot allege that the classics of marxism-leninism did not formulate a given though or resolve numerous contemporary questions and problems. This is a task for each new generation of communists. They are fully and totally responsible for the state of their ideology and its purity as well as for the destiny of building socialism in each and every one of the countries. In other words, our attitude to marxism-leninism ought to be the same as Lenin's to Marx's theoretical output: "Let us not treat Marx's theory as something final and inviolable. On the contrary, we are convinced that his theory is only the cornerstone for this science, which socialists ought to develop further in all directions if they want to keep up with life. We think that for Russian socialists particularly necessary is an independent working through Marx's theory, because this theory gives only general guiding theses, whose particulars apply differently to England than to France, Germany than to Russia." ("Works," v 4, p 218).

Marxism-leninism has always been a critical and revolutionary theory in relation to objective reality, to other ideologies and to itself. That is why it could and has performed the functions of the proletariat's ideology. Marx, as we know, defined various types of nonmarxist ideologies as false consciousness. This qualification to some extent applies also to pseudo-marxist ideological apologetics. No wonder then that when today we want to answer the question how to build socialism, in what way it should function in complex internal and external conditions in order to avoid errors and distortions with which we have dealt recently, we encounter numerous difficulties resulting from a lack of sufficient knowledge. And this situation will continue until we get rid of the burden of all that which has been hampering the development of our ideology.

Polish marxists are faced with a task of great importance: to answer the question how to build socialism in the concrete conditions of our country. We know the general principles. They, however, do not suffice to create and correct a social system already functioning. In the latter case the general principles and mechanisms require a detailed concretization. The development of socialism must be based on the solid results of scientific studies and a whole system of their verification. I have in mind both studies of the economic base and of its superstructure. I do not delude myself that we can quickly organize and develop such studies nor that we can totally escape all lapses and errors. I think however that we can make an important step towards the rationalization of building socialism in this way and the prospect of our further progress will become brighter. We can then slowly but continually eliminate elements of spontaneous development, subjectivism and voluntarism in steering it, thus avoiding new and perhaps much greater difficulties and conflicts.

Rationalization of building socialism represents only one side of the complex problem of our development, but it is the one which conditions the effective

functioning of the other, namely the ideological and educational influence on society and the shaping of socialist consciousness, morality and the corresponding human attitudes. In the "Critique of Gotajski's Program," Marx wrote about the transition period from capitalism to communism: "We are dealing here not with a communist society which developed on its own foundations, but on the contrary, with one which has only emerged from a capitalist society; which therefore in every respect--economic, moral and psychological--still bears the characteristics of the old society from which it has originated." (K. Marx, F. Engels: "Selected Works," v II, Warsaw 1949, p 14).

The cited thought clearly applies to our society. Particularly in the post-August period the destruction of socialist ideas in social consciousness increased. Today the restoration of faith in the ideas of scientific socialism is not a matter that can be resolved easily and quickly. Numerous discussions and attitudes both in party organizations and in broad social circles testify to this. From the wealth of socialist ideas only the conviction of equality and justice, which socialist system ought to assure, has remained in the social consciousness. The concepts of "equality" and "justice" are therefore declined through cases both by the adherents and enemies of socialism. At the same time we are not always aware of the complexity of this question: To what extent and in what areas can socialism assure equality and justice, and to what extent and in what areas it cannot yet do so at all? "The image of socialist society as a state of equality," wrote Engels in a "Letter to August Bebel" 18-28 March 1876, "is a one-sided French notion going back to the old slogan of 'liberty, equality and fraternity,' a notion justified as a certain developmental step in its time and its place, which however like all the other one-sided notions of former socialist schools, must now be overcome because they only sow confusion in the minds and because more precise ways of presenting things have already been found." (K. Marx, F. Engels: "Selected Works," v II, p 33).

V. I. Lenin referred directly to this thought in "The State and Revolution": "Justice and equality cannot be introduced in the first phase of communism: differences in wealth will remain and these will be unjust differences, but the exploitation of man by man will be impossible because no one will be able to seize the means of production, factories, machines, land, etc, as private property. Refuting Lassale's petit-bourgeois, nuclear slogans about 'equality' and 'justice' in general, Marx presents the course of development of communist society, which at first is forced to bear only the 'injustice' in which the means of production are held by particular individuals, which however does not have the ability to abolish right away the greater injustice consisting of the distribution of the objects of consumption 'according to work' (and not according to needs)" ("Works," v 25, p 502).

Quoting the above statements of Engels and Lenin, I only wish to show how much harm our propaganda has caused by repeating carelessly, without reservations and implicitness the slogans of equality and justice in socialism. They become a kind of boomerang striking those who in a simplified way have been propagating them. In our conditions of a multitiered economy, the problem of equality and justice is theoretically even more complex and extremely tangled in practice. Thus we must rid ourselves of delusions and mystifications and

return to authentic marxist-leninist ideas, enriching them by the results of concrete scientific studies of contemporary complex Polish reality. Only on this basis can we effectively shape and correct social consciousness and practice, human feelings and behavior.

A great many more examples of similar "demarxification" of marxism could be quoted. We need therefore purification work. From the multilayered deposits we must extract authentic marxist-leninist ideas. This activity ought to be undertaken on the basis of the classic source works. But this is only one side of the task facing Polish marxists today. The other side, greatly more important and difficult, consists in further developing marxist-leninist theory on the basis of the achievements of contemporary sciences and experiences of social life in many countries. Marxism-leninism, as we have said, can in no way be treated as a closed theoretical system. If so, it would be suitable only for a museum of relics, while instead it must perform important cognitive, methodological and practical functions. It will perform them under the condition that it undertakes the many correct problems, thus perfecting itself internally.

The above conditions must be met if it is to perform effectively the educational and upbringing functions with regard to party members and the broad masses of the nonparty. In other words, when marxism becomes attractive thanks to solving effectively the problems of people and formulating as well as realizing new proposals, it will become an ideology increasingly more received and accepted by society. It will then also begin to gain victories in the ongoing ideological-political struggle between particular countries, continents and the world as a whole. If, on the other hand, the gap between the practice of social life and theoretical ideas continues and grows, theoretical ideas will remain artificial unless they begin to get ahead of, and give support to practical solutions. The effectiveness of the ideological-educational function of this theory will also be clearly illusory.

Communists cannot renounce the development and propagation of their ideology and its instillment to an ever-growing extent in the social masses. Yet they also are realistic: they are conscious of the impossibility of removing from our social life numerous nonmarxist ideas by administrative measures: those must be defeated in an ideological struggle. The latter, on the other hand, requires: 1) solid argumentation; 2) conformity of the theory with practice; 3) skillful implementation of the ideological-educational work.

Particularly important educational role is performed by schools of various levels. In this regard too our adversaries tried to realize the conception of a school neutral in regard to ideology or outlook. In reality their aim was to put into effect antisocialist education and upbringing of the young generation. In class societies, however, schools are not and cannot be neutral. They avowedly or secretly serve the interests and goals of the classes which rule economically or politically. Let us refer to Lenin's following evaluation: "The school of the past claimed that it desired to create a broadly-educated man, that it taught knowledge in general. We know that it was a thorough lie, because the whole of society was built and based on a division of people into classes, into the exploiters and the oppressed.... In schools

the young generation of workers and peasants was not so much being educated, as rather it was trained to meet the interests of the bourgeoisie. They were being educated this way so that they would become servants convenient for the bourgeoisie who could bring it profit without disturbing its peace and idleness. That is why in rejecting the old school we presented ourselves with the task of adopting from it only what we need in order to acquire true communist education." ("Works," v 31, p 286). In the same speech entitled "The Tasks of Youth Unions," Lenin at the same time stressed that all that was valuable ought to be adopted from the old school, it must however serve communist and not any other education and upbringing of the young generation.

In building, developing and transforming the educational-upbringing system of various levels, the above words of Lenin were not much remembered. Therefore lapses, deficiencies and errors revealed themselves with particular severity in the post-August days and particularly in the period of strikes in schools of higher education, secondary schools and in some places even in elementary schools. Those concerned some students, a part of the teaching personnel, programs and processes of instruction and political, union and youth organizations. For example, as a rare paradox we can consider the fact that the NZS [Independent Students Union], in the past officially recognized and partially functioning with state money, directed its basic activity against the socialist state, the party, our vital interests, etc. This means that education requires a prompt and at the same time thorough reconstruction in the broad sense of the word. It must be subordinated to the needs of building socialism and in no case can it constitute a structure preparing antisocialist, or even neutral, cadres.

Yet despite several years of discussions, in secondary schools preparatory philosophy is still not taught, nor is there a study of religions. The learning youth is deprived of the possibility of taking a closer look at the nature of scientific and social phenomena. When one considers also the methods of teaching and learning various subjects it becomes understandable why students are not prepared for independent analysis of various problems in wider perspectives, or perceiving them in the surrounding reality and in analyzing them correctly. One could say therefore that our schools unsatisfactorily perform their main duty: to prepare youth for independent life in today's complicated world. That is why, among other things, it is susceptible to various irrational and demagogic influences. Closing our eyes to these deficiencies, which has anyhow been practiced for many years, is a glaring example of underestimating the upbringing role of the school in the process of building socialism.

In the system of higher education, on the other hand, we have not been able to organize and realize more thorough studies in the theory of marxism-leninism. Knowledge of marxism is still slight both among students and among the majority of the scientific-teaching personnel. Most often it does not exceed the level of popular pamphlets and simplified or even distorted press information. That is why ideas found in various nonmarxist and even openly anticommunist theoretical doctrines, recently promoted even in our country, find their way to that milieu. We are paying a high price for the lapses and errors committed.

The weaknesses, however, particularly concern the education and upbringing of college youth. In consequence of the forced Lodz agreements, there were efforts to eliminate marxist philosophy and sociology from the city's schools of higher education. These subjects were replaced either by history of philosophy or else by various types of nonmarxist philosophy. In one of the schools marxist political economy and political sciences were pushed to the margin. Not infrequently college teachers incited students to antisocialist pronouncements. If this situation continued, future graduates would be left without theoretical marxist preparation. In the course of future years all the negative consequences of that would reveal themselves in the spheres of practical, scientific and cultural activities.

Although in the current academic year new programs from the sphere of social sciences have been added to the curriculum, in my opinion they do not yet represent those contents which ought to be delivered to the consciousness of the students of socialist colleges, as traces of the Lodz postulates have remained in them. The problem is made more significant by the fact that those programs are being implemented by the same people who in the post-August period of "Sturm und Drang" [Storm and Stress] transgressed all permissible limits of ideological and practical tolerance. I would postulate not only restoring the teaching of marxist philosophy contents more broadly and thoroughly, and bestowing an appropriately high rank on marxist political economics, but also introducing the teaching of the theory of scientific socialism. The problem is significant for as experiences of the past months have shown, the knowledge of theoretical questions of socialism, its various trends, general and particular laws and mechanisms of building socialism among college youths (as well as among the whole of society) leaves much to be desired. We cannot permit that the minds of future builders of socialism be penetrated by ideological doctrines alien to us and that college youth perceive marxist ideology through the purposely distorted mirror of anticommunism.

The problem of shaping the views, feelings and attitudes of youth is today an essential issue. I do not think however that through education alone we can achieve the intended goals. After all, the mass media, film, literature, visual arts, cultural entertainment activity, interhuman relations at places of work and residence, the functioning of the whole sociopolitical and economic system and the level and methods of meeting various needs, etc., have a significant role to play as well. They can strengthen or weaken or even effectively annihilate the educational results of the school and other educational-upbringing institutions. Training of work and respect for it ought to play an important role in the whole process of the education of youth; hence the importance of politechnization in elementary education. We must remember about it in undertaking the socialist renewal of our whole lives; otherwise the renewal will remain more verbal than real.

The marxist-leninist political party must of course be the initiating and leading force in the process of shaping the consciousness and attitudes of the working class. Thus we should give a deeper thought, particularly with regard to our current conditions, to the following statement of Lenin formulated in the article entitled "On Mixing Politics With Education": "We must always deepen and expand work with the masses. Without doing so, a social

"democrat is not a social democrat.... This work is, as we have already pointed out, always necessary: after each defeat we can and must remember it and stress its importance because its weakness is always one of the causes of the proletariat's defeat. Also after each victory we must always remember it and stress its importance, otherwise our victory will be in appearance only, its fruits will not be secured and its real significance from the point of view of our whole great struggle toward the ultimate goal will be negligible and may even turn out to be negative...." ("Works," vol 8, p 458-459).

12270

CSO: 2600/958

PROVINCIAL TRADE UNION DEVELOPMENTS REPORTED

Six-Months Trade Union Activities

Gdansk DZIENNIK BALTYCKI in Polish 25 May 83 p 3

[Article by Andrzej Sitek: "After Six Serious Months"]

[Text] Trade Union Affairs of Gdansk and Gdynia Longshoremen

An increased interest in not only home affairs but also in the affairs of supraplant structures is being felt in plant trade union organizations. It seems that sailors, fishermen and dockworkers, from the perspective of the special nature of these professions and the community of trade union interests, have a very good chance to quickly set the bases of such structures.

I am conversing with the administration office's chairman Gerard Okroj and Franciszek Lis, who heads a circle of pensioners and retired folk with Gdynia's trade union organization at the headquarters of the Professional Trade Union of the workers of the Administration of the Port of Gdynia. Both believe that the trade union movement will not lead to the division of labor. The union intends to defend the interests of all workers, irrespective of the fact whether they have confirmed their union affiliation or not.

Retiree and pensioner issues greatly dominate the efforts of the union. Eighteen hundred former longshoremen belong to the plant's circle, even if all of them are not members of the union again. They come along and ask, however, about trade union services and social assistance. There is also no shortage of other issues which interfere.

The trade union concerns itself with organizational matters and issues of union property; it has assumed some of the authority of the social commission. In the entire range of union activities, there are also the exercise of authority originating from the Port Charter, the introduction of changes to the catalogue of unit standards and wages, the satisfaction of everyday needs, the control of the correctness of social nourishment and the distribution of industrial articles, difficult to acquire. The focus of the unionists' attention is equally on the housing problems of the longshoremen and on the issues of recreation, holidays and summer camps. In order to integrate working families, the complete satisfaction of plant needs in providing summer recreation for young people and children and the guarantee of space in nurseries

and kindergartens are envisioned. The union accorded assistance in accident cases and returned the costs of medicines during long-lasting and expensive treatment; it also granted government assistance aid.

An increase in port union activity was noted after the election. The union representative participates in evaluating work issues. Manual workers now work with the authorities, something which makes the union more responsive to the port workers employed in transshipping.

So much for outside plant issues. On the surface one sees the need for cooperation with profession trade unions from other Polish ports. The question here is not only about the working out of a joint position in the talks in the Agency for Maritime Economy, but also about an increase in the significance of joint union activity and the growth of the standing of the longshoremen in society, which knows far more indeed about miners, mill workers and even sailors and fishermen than about longshoremen. Transshipping comes across as grey, thankless, monotonous and strenuous. But the effectiveness of our sea economy is to a great extent dependent on the efficient hands and brains of the longshoremen. The level of transshipping is the yardstick measuring the rate at which the country gets itself out of this economic crisis.

The movement is considerable in the Administration Center of the port of Gdansk at the union local. I am having a conversation with a group of trade unionists and with the vice-chairman of the Profession Trade Union of Administration Officials of the port of Gdansk, Jan Masalski. The section administrators of the union have been elected, and it was a nice piece of gossip that it was a woman, Krystyna Wedzina, who remained the chairperson of the important Department of Shipping Services, even though the department, as well as the port itself, employs mostly men.

Housing issues keep most trade unionists awake at night. There are several hundred applications, but only 15 apartments available. A hotel has been transformed into apartments for 80 families on a rotational basis. But these are only secondary measures, while the shortage of apartments threatens to force a portion of the longshoremen to leave, especially those whose families live in the interior of the country. During the organization of the union, there was talk that the workforce would be conciliatory and would not be at a variance with management. In the meantime, everyday life sees incidents of interference by and disputes with management. An example: management wants to straddle a stoker with the costs of repairing a boiler. The boiler burst 20 minutes after the stoker had started his work. Improper work procedures were cited; the union, however, is searching for real reasons for the boiler's demise. Most likely, the boiler was just too old. It is easy to hit the worker for it in the pocket book, and it is difficult to defend him. In any event, the issue is in the process of settlement and the union's position is unequivocal.

And it is also not a question of defense at any price.

The vice-chairman, Jan Masalski, remarks that it is impossible to defend loafers, who notoriously violate the principles of work discipline, or workers who abuse the trust of the superiors and colleagues.

"The Trade Union Must Have a Face"

This is what the poor trade unionists are saying. The union wants to be present at all apportionments of services for the workforce. Recently, the union accepted new regulations from management. At stake is a chance to raise wages for good workers and the union supports this idea.

Attempts have been undertaken to finalize exchanges without hard currency with the trade unionists from Bulgaria. Similar contracts are intended for Czechoslovakia and the GDR. The plant recreation center in Golunie has been made available to some workers who gladly took advantage of the proposal for rotating vacations.

As Stanislaw Brzeski, the plant public work inspector, stated, the trade union is also supposed to have its own idea on the plant's program on economization. A review of the positions is necessary from the perspective of the requirements and basis of employment. A public commission will conduct such a review. The question here is not about longshoremen employed in transshipping; personnel reserves can still be found in the port, especially among the intellectuals.

A scale of regards has been introduced from every load in the Northern Port and the longshoremen there are satisfied. We need to adjust the elements of wages to binding standards more extensively in the remaining regions so that workers can see that it pays to work better and more productively. The union is requesting the development of an extensive education program so that it can be possible to advance workers to various positions, depending on changing requirements.

Thus far, 11 percent of the workers from the port of Gdansk have joined the union, and the number keeps growing from day to day. The 9th of June is the last day for all those to apply who wish to declare their desire to maintain their union status with trade union legal services.

Barely half a year has passed for union activity since registration and that is still too short a time. Trade union commissions have already been set up in housing, and public and legal matters. A team has also been set up which will turn out a local paper with the name GLOS PORTOWCA [THE VOICE OF THE LONGSHOREMAN].

The trade unionists from the Gdansk organization are saying: "We do not have any example of supraplant structures in our seaports, but we are trying to take advantage of the union proposals from the mill workers." In any event, the longshoremen's idea of professional community on a trade union basis is beginning to gather steam.

Development of Supraplant Unions

Warsaw EXPRESS WIECZORNY in Polish 26 May 83 p 7

[Article by ts: "New Trade Union Structures Are Coming Into Being"]

[Text] Trade Union Thursday

From day to day more and more trade union organizations are opting for the establishment of nationwide structures. During a meeting of the Consultative Team on matters of the Professional Trade Unions with the National Metropolitan Council, we conducted an interview with trade unionists from Cefarm, the Warsaw-based Pharmaceutical Supply Enterprise [PZF].

Zbigniew Dropa, chairman of the Professional Union of PZF workers from Cefarm in Warsaw told us: "Together with the trade unionists from Cefarm in Poznan we are the initiators of the supraplant unions. Our working interests have little in common with the interests of health service workers; the Cefarm enterprises operate on an economic system of accounts and we are governed by other principles than budget units. As pharmaceuticals, we want our own national representation. Our structure will be joined by around 20 trade union organizations from all over the country."

The trade unionists from Cefarm run into many problems during their daily union operations. Because of the large number of centers and the shortage of contacts between the individual groups of workers, the number of union members is not very large. There is also a variety of views when it comes to which working issues need to be settled first. This is a result of the differences between the professional groups making up Cefarm. The most important task facing the organization is described by the trade unionists to be an improvement in the working conditions of all working groups and a greater concern for the issues of the female part of the workforce.

The trade unionists from the Independent Self-Governing Trade Union [NSZZ] of workers from the Zeran Meat Plants also turned to the Consultative Commission with a request for assistance. The last of the consultative meetings of the professional trade unions from the meat industry plants before the appointment of a Federation of Professional Trade Unions of Workers from the Meat Industry will shortly take place.

Trade unionists from Bailegostok, Zielona Gora and Warsaw presented an initiative for the appointment of the Federation. Eight-seven meat industry plants expressed their desire to join the Federation during the consultative meetings in Bialystok. Now, there are more than 100 interested plants.

Jerzy Lewandowski, the NSZZ chairman from Zeran, told us: "We would like to combine all trade unions operating in meat industry plants into a federation. People have been talking a lot recently about our privileges and allowances, but no one perceives how exceptionally great our workload really is.

"In order to deal with the most pressing working requirements, we need a strong trade union organization and this organization must comprise all the unions exclusively from our industrial sector."

"When will the final version of the planned statute be presented to the trade unionists?" we asked Zeslawa Gromkowska, a member of the Trade Union Administration.

"We do not want to abandon the chance for changes and improvements too soon, because the Statute Commission's efforts will go on for a long time yet. We realize that we have to adapt ourselves to absolutely all proposals, which will be a result because of the statute. It is possible that we will hear of these proposals again during the meeting in Warsaw.

The trade unionists want to exert special pressure in the work of the Federation for the solution of workforce welfare and daily problems. The problem to be decided is the one concerning recreation and health spots for meat industry workers, as well as the issue of suitably protecting the health of the worker at his place of work. The trade unionists believe that the Federation, as a collective organization, should work on those issues most important to the country. How to solve the problems in the factories should be the work of the factory organizations.

Enriching Forms, Programs of Union Activities

Warsaw EXPRESS WIECZORNY in Polish 26 May 83 p 7

[Article entitled: "The Enrichment of the Forms and Programs in the Education of Trade Union Activists"]

[Text] At least a half of those individuals elected to positions of authority with the plant trade union organizations are novices who have up until now held no positions in professional trade unions. Around 13,500 unions have gained legal status already, while around 1,500 petitions for registration from other organizations are in the courts. More and more elements are being touched by the process of setting up supraplant trade unions structures. At the same time, a significant part of the experiences of previously active unions is turning out to be of little applicability today since the legal basis of union activity has changed, as well as the situation of interplant relations of the enterprises and institutions. All this points to the enormity of the need to inform people of their union and working powers and also of the difficult economic and sociopolitical conditions in which the new professional movement is growing and operating. In dealing with this need of the trade unionists, the public consultative commission, working with the State Council, prepared and adopted at its last meeting a draft system for educating the aktiv of the professional trade unions during the 1983-84 time-frame. This concept will be further defined.

Union courses, conducted from February of this year as a result of the commission's work in Jacranka near Warsaw and Katowice, are facilitating the training of more than 8,000 people before the end of the year; this is still

considerably less than what is needed. For this reason, an extension of the parameters of trade unionist education, a simultaneous enrichment of its form and a diversification of its programs are envisioned.

The ongoing 5-day courses in the 2 centers will continue for this year yet, but in groups of trade unionists from individual subsectors and on the basis of a modified program. From September, the implementation of a new training center is planned, along with a center for preparing instructor and lecturer specialists for trade union training and leadership activists through the supraplant structure.

From the beginning of next year, a Trade Union Center, conducting 7 to 10-day courses for the chairmen of plant administrations, should become operative. The center will be busy with the problems of union work methods, economics and wages, labor and union law, social policy, education and culture. There is a proposal for the establishment of an intraunion training council made up of representatives from nationwide organizations. The central education of trade unionists will be directed and programmed by the public consultative commission in accordance with the position of the council.

Planned for next year is also the mobilization of 13 regional, intraprovincial centers for trade union education. These centers will train during courses lasting several days all remaining plant members and trade union department authorities (except chairmen), besides others.

Discussion meetings, organized for 1984, are to take place in all provinces for the organizers of the plant trade union, without taking them away from their work (i.e., on Saturdays and Sundays).

All these plans, however, cover only the transitory period, the building of the structures of the reborn trade union movement. After the completion of this process, a transformation of the trade union training centers into a nationwide federation of professional trade unions is planned. On the other hand, regional centers are to gradually revert to the control of nationwide organizations, becoming their professional centers.

Development of Supraplant Trade Unions

Gdansk DZIENNIK BALTYCKI in Polish 26 May 83 p 1

[Article by PAP: "What Kind of Supraplant Structure?"]

[Text] The Process of Building the Trade Union Movement

A Polish press journalist writes: "The process of building the trade union movement has entered the highest organizational phase." From more and more newer sectors of the economy and professional centers we are receiving word of attempts to create nationwide trade union organizations. The most strongly felt tendencies are taking place in mining, education, transport, agriculture and, especially, in those sectors with the highest degree of workers organized

into professional trade unions. Other centers, such as those of textile-workers, merchants and workers from the machine and glass industries, are also undertaking the first steps in the direction of setting up supraplant structures. Such small groups of employed people want to join professional partnerships in small factories that it is impossible to establish trade union organizations in them. For instance, restaurant musicians, religious officials and officials of clubs and political and social organizations are interested in professional partnerships.

Of course, the trade unionists themselves choose the form of the supraplant organization, and there are two already known possibilities: a federation or a uniform, nationwide professional union. The trade unionists also decide on the eventual establishment of indirect structures where it is necessary because of organizational reasons: provincial or district, depending exclusively on the nationwide organization law. This law also decides the other issues of interunion activity, e.g., the rules for dividing membership fees between plant organizations and a single nationwide one. It also takes into consideration those issues on which the federation itself makes decisions, and other issues, for which plant organizations are responsible.

The selection of the form of a nationwide organization is a difficult matter, the result of which is that decisions are made slowly, coming only after often-repeated meetings and sharp and pointed discussions. This is understandable, since both possibilities have their pros and cons. Above all, the selection depends on the size and number of factories. At the same time, a declaration for a form of federation, in which plant trade union organizations maintain their own legal status, often is the result of past experiences and the apprehension of the trade unionists of a return to heirarchal institutions, which threaten the bureaucratization and separation of the "the top" from the plant organizations. However, a number of consequences result from this: financial considerations. We need to define the share of federation's property for the plant organizations, while plant organizations are only the administrators of the property charged to them by the union in a uniform supraplant structure. At the same time, the federation variant complicates and extends the decision-making and execution process. It demands the settlement of the problem--whether the vote of individual organizations of member federations counts only once or must the vote's makeup be determined as applied to the size of the plant organization.

The problems are many, but the trade unionists themselves must weigh and solve them. As has been stated however at a meeting of the Public Consultative Commission with the State Council, it is to be expected that the commission will shortly publish extensive and specific explanations as to what consequences will follow from the selection of a federation or a uniform structure.

Above all, 2 arguments with basically the same strength are causing friction in the discussions of the selection of a nationwide organization: the greater strength to get one's way along with effective action, or greater democratization of internal union activity. This time, it seems that the latter argument will dominate: a majority of centers is inclined towards selecting a federation.

For the same reasons, in order to affirm independence and autonomy, there is a tendency growing to break down individual work sectors in the supraplant organizations. In a center where a single large union, comprising all the activities of the entire department was previously active, several, or even several dozen nationwide organizations may now come into being. When making such decisions, it is worth considering whether this organization will be strong enough to fully take advantage of its legal powers, and whether the trade unionists will be able to maintain an organization which represents only a small group of workers. Only after taking into account all the "fors" and "againsts" will we get a decision agreeable to the expectations of trade unionists and the requirements of effective operation. In any case, there is one binding rule in all these activities and at all levels in the building of the professional movement: there will be nothing done to or for the trade unions without trade unionist participation.

Trade Unions After 5 Months

Opole TRYBUNA OPOLSKA in Polish 30 May 83 p 3

[Article by Zbigniew Jurkiewicz: "Where Are We?"]

[Text] Professional Trade Union 5 Months After the Beginning

In the several weeks since the State Council's Resolution paved a legal way for the professional movement to set up nationwide structures, it is already impossible to count the initiatives tying plant trade union elements to the next higher levels of organization. It is worth remembering that the first to do this were steel mill and mining workers, who decided as early as April to set up nationwide uniform professional trade unions in the mills and mines. A great wave of workers followed suit shortly thereafter. Metalworkers from Warsaw (the Warynski Plant) and machine industry workers from Lublin proposed already in early May the appointment of trade union federations for the 2 largest magnates of our economy. Agricultural and foodstuff industry workers organized soon after in Wloclaw, as did the trade unionists from several Poznan municipal communications facilities. In Lublin, there was already a center which initiated the establishment of a federation for Polish motor transport workers, while in Pilo, flour producing workers have done likewise.

According to the most recent reports, teachers, construction workers, merchants employed by Spolem, woodsmen and paper manufacturers are also setting up trade union federations. And it is impossible to foresee how many more will do the same before this news makes it to our readers. The fact that trade union matters began to move distinctly more quickly in the spring and with greater decisiveness, as if a second course had been added. Could it be that the degree to which the unions have organized, the accomplishments already made, the position won in society and, finally, the first evidences of trust have provided them the new strength to go forward? Or maybe, it is a bit too early, from another perspective, to speak of accomplishments, positions or trust when a crisis could push us strongly into the ground?

However we evaluate the information, and however carefully we deal with the issue, we always have to let the facts stand, if only to determine where we are. Some then say that it has been 5 months since the trade unions were organized, that they are now operating in all the major industrial plants and public service institutions, that they are made up of from 30 to 50 percent (sometimes more) of the workers and that this means that they are now organizations numbering several thousand workers and specialists each. After these basic units come the midsize enterprises, according to the plan for the professional movement, and this will be a most important change. Currently, there is a lot going on at this level: the organizations are growing as new members are quickly added. These are looking for new ties which go beyond the factories most energetically, convinced that only with a large group will they find the support for the kind of activity they plan. On the other hand, we still have a twilight zone, an area or diffused conglomeration of workers who are most difficult to reach, a place where there are the most apathetic or cautious people. But even in this area, there are things happening at the same time which are as important as the strikingly high degree of professional organizations of officials from education and the foodstuff industry.

Therefore, where are we? In countries with long trade union traditions like France, England or the United States, it is considered to be standard when 25 percent of the workers are organized in a professional movement. In Poland, where the most difficult period of the economic crisis has been overcome and the social conflicts left behind, the new professional trade unions, forced from the first days to fight through a boycott organized by the entire anti-socialist opposition, have exceeded this standard.

If it is so and if it is so known how hard it was to achieve all, then what can be said of the results? The answer, it seems, should be easy. The chance to form such unions, made possible by the resolution, was what the workers really wanted, what they really need, and what no one from above or from behind can harm. There should be time and experience so that the work teams can convince themselves that the words of the movement's first organizers will be protected by law, by the election of officials, by the bringing up of workers' problems, by their own activity and the effectiveness of their solutions, and by their relations with plant administrations and the leadership of the state. And this time has been moving along, and the experiences have been mounting.

Although still weak and often tied up with the headaches of organizing, or contributing too little to the lives of the workforces because they are too little experienced or bewildered by the number of problems to be solved, the trade unions are still basically that which the people need and what they should be.

What was so important yesterday will still play an even greater role tomorrow. This is in answer to the question what does it mean to be a necessary trade union. A good union is one which takes hold of the issue of organizing work and the systems of rewards, completely understanding the situation in the factory and feeling responsible for the results of applied decisions. It is

also one which represents the concept, adopted by the workforce, of the management of the welfare fund, the solution of the housing problem and the distribution of various services or allowances belonging to the workforce. Finally, it is the one which guards fairness and the economic efficiency in the places of labor, in relations with the workforce.

But it is also very difficult to be a good trade union, first skillfully understanding and then wisely bringing together that which is possible with that which is necessary, contributing what is learned to plant management systems of the direction of the country. However, life teaches that the new trade unions are handling their tasks in a more competent fashion, and are most quickly learning to think of themselves as an active and coresponsible partner of the authorities. They are contributing ever better ideas, however, to the centers of primary activity.

12247

CSO: 2600/994

MEMBERSHIP, TASKS OF NEW NATIONAL COMMAND FOR AGRICULTURE

Bucharest SCINTEIA in Romanian 10 Jul 83 p 1

[Article: "Under the Chairmanship of Comrade Nicolae Ceausescu, There Was Established Yesterday the National Command for the Implementation of the National Program for Obtaining Certain and Stable Yields by Increasing the Production Potential of the Land by a Better Organization and Use, in a Unitary Manner, of Agricultural Land and of the Entire Area of the Country, by Executing Drainage Work and Combatting Soil Erosion"]

[Text] On 9 July, under the chairmanship of Comrade Nicolae Ceausescu, secretary general of the Romanian Communist Party, president of the Socialist Republic of Romania, a meeting was held to establish the National Command for the implementation of the national program for obtaining certain and stable agricultural yields by increasing the production potential of the land, by a better organization and use in a unitary manner of agricultural land and of the entire area of the country, by the irrigation of 55-60 percent of the arable area, by executing drainage work and combatting soil erosion.

In accordance with the decisions of the plenum of the Central Committee of the Romanian Communist Party of June 1983, the chairman of the National Command is Comrade Nicolae Ceausescu, secretary general of the RCP and president of the Socialist Republic of Romania.

The members of the National Command are: Comrade Elena Ceausescu, member of the Political Executive Committee of the RCP Central Committee, first deputy prime minister of the government; comrades Constantin Dascalescu, member of the Political Executive Committee, prime minister of the government; Emil Bobu, member of the Political Executive Committee, secretary of the RCP Central Committee; Ion Dinca, member of the Political Executive Committee, first deputy prime minister of the government; Manea Manescu, member of the Political Executive Committee, vice president of the Council of State; Gheorghe Oprea, member of the Political Executive Committee, first deputy prime minister of the government; Nicolae Constantin, member of the Political Executive Committee, chairman of the Central Council of the General Union of Trade Unions; Constantin Olteanu, member of the Political Executive Committee, minister of national defense; Ion Patan, member of the Political Executive Committee, minister of technical-material supply and control of

the management of fixed assets; Gheorghe Stoica, secretary of the RCP Central Committee; Stefan Birlea, candidate member of the Political Executive Committee, chairman of the State Planning Committee; Ion Ursu, candidate member of the Political Executive Committee, first deputy chairman of the National Council for Science and Technology; Nicolae Giosan, candidate member of the Political Executive Committee, first deputy chief of the section for problems of party work in agriculture in the RCP Central Committee; Ioan Avram, minister of the machine building industry; Alexandru Necula, minister of the machine tool, electrical engineering and electronics industry; Vasile Bulucea, minister of transportation and telecommunications; Trandafir Cocarla, minister of electric energy; Ion Cioara, minister of silviculture; Ioan Folea, minister of geology; Petre Gigea, minister of finance; George Homostean, minister of the interior; Ion Tesu, minister of agriculture and the food industry; Ion Iliescu, chairman of the National Council for Water Resources; Pantelimon Gavanescu, first secretary of the Central Committee of the Union of Working Youth; Nicu Ceausescu, secretary of the Central Committee of the Union of Working Youth; Ferdinand Nagy, minister state secretary in the Ministry of Agriculture and the Food Industry; Marin Vasile, chairman of the National Union of Agricultural Production Cooperatives; Tiberiu Muresan, chairman of the Academy of Agricultural and Silvicultural Sciences; Ion Ceausescu, deputy chairman of the State Planning Committee; Col Gen Vasile Milea, first deputy minister of national defense; Col Gen Marin Nicolescu, deputy minister of national defense; Neculai Mantz, deputy minister of agriculture and the food industry; Ion Rusinaru, president of the Bank for Agriculture and the Food Industry; Petre Leca, state secretary in the Ministry of Agriculture and the Food Industry; Virgil Dohre, director of the Institute for Land Improvement Studies and Designs; Lt Gen Vasile Dragomir, chief of the Military Topography Directorate; Lt Gen Constantin Antoniu; Nicolae Popescu, director of the Institute for Geodesy, Photogrammetry, Cartography and Organization of the Territory in the Ministry of Agriculture and the Food Industry; Silviu Curticeanu, chief of the chancery section of the RCP Central Committee; and Gheorghe David, counselor to the secretary general of the party--secretaries of the Command.

Comrade Elena Ceausescu and comrades Constantin Dascalescu, Emil Bobu and Ion Dinca have been elected deputy chairmen of the National Command.

The following comrades are members of the Executive Bureau of the National Command: Ion Dinca, chairman of the Executive Bureau, and Ion Patan, Constantin Olteanu, Gheorghe Stoica, Nicu Ceausescu, Ion Tesu, George Homostean, Ion Iliescu, Ion Ceausescu, Ion Rusinaru and Neculai Mantz.

During the session, Comrade Nicolae Ceausescu presented organizational measures and the immediate tasks assigned to the National Command in connection with the mobilization of all material and human forces for the utilization, with maximum efficiency, of the entire agricultural area of the country, the execution, from a unitary point of view, of projects for irrigation, drainage, combatting soil erosion and water management, for increasing the agricultural potential of the land, and for obtaining superior agricultural yields, in accordance with the decisions of the 12th Congress and of the National Conference of the Romanian Communist Party.

Also, measures were presented in regard to the following: the creation of county commands; the establishment of a central group of designers and of collectives of specialists for the counties and for the principal targets; the organization of the work sites and proceeding to the execution of the work; the determination of the machine system for land improvement work, standardization and concrete tasks in this area for the producing factories; the obligations of the Ministry of Agriculture and the Food Industry, the Academy of Agricultural and Silvicultural Sciences, and the research units in establishing proper technologies for irrigated crops, organizing the territory and increasing the production potential of the land.

CSO: 2700/273

BLAGOJE TALESKI NOTES PROBLEMS WITH NEIGHBORING STATES

Belgrade TANJUG in English 1625 GMT 28 Jul 83

[Text] Skopje, 28 Jul (TANJUG)--Yugoslavia wants good relations with all neighbours. However, in relations with Bulgaria, Greece, and Albania certain problems exist. Problems for which Yugoslavia is not responsible and which account for the fact that not all desired results are recorded in bilateral cooperation with the respective countries.

Presidency President of the Yugoslav Republic of Macedonia Blagoja Taleski states the above in an interview in the magazine MAKEDONIJA of the Macedonian organizations for ties with emigrants. The interview appears on the 80th anniversary of the Ilinden.

Referring to Yugoslav-Bulgarian relations, Taleski said that they continued pressed by the well-known Bulgarian positions toward new Yugoslavia and the basic elements of Bulgaria's internal and foreign policies. In the context of Bulgaria's attitude toward Yugoslavia in general and the Republic of Macedonia in particular, Taleski singled out Bulgaria's negation of the existence of the Macedonian national minority in Bulgaria (which had for a period after World War II enjoyed all rights as a national minority, and the Greater-Bulgarian attitude toward the Macedonian nation, as a whole, its statehood and history.

Taleski said that Yugoslav-Albanian relations were heavily pressed as a result of Albania's well-known anti-Yugoslav policy and its support to the counter-revolutionary forces acting from the positions of Albanian nationalism and irredentism in the Yugoslav Autonomous Province of Kosovo.

Yugoslavia's relations with Greece in essence record a positive development, Taleski said but drew attention that a problem existed since Greece does not recognize the existence of the Macedonian national minority on its territory.

CSO: 2020/55

END