



1992-01-08 A 9 12

AIAA-92-2750

Subsystems for the Extended Range Interceptor (ERINT-1) Missile

DISTRIBUTION STATEMENT A

**Approved for public release;
Distribution Unlimited**

R. Herman
LTV Aerospace & Defense Company
Dallas, TX

J. Butler
U.S. Army Strategic Defense Command

PLEASE RETURN TO:

BMD TECHNICAL INFORMATION CENTER
BALLISTIC MISSILE DEFENSE ORGANIZATION
7100 DEFENSE PENTAGON
WASHINGTON D.C. 20301-7100

19980527 155

AIAA SDIO Annual Interceptor Technology Conference

May 19-21, 1992 / Huntsville, AL

Accession Number: 4275

Publication Date: May 19, 1992

Title: Subsystems for the Extended Range Interceptor (ERINT-1) Missile

Personal Author: Herman, R.; Butler, J.

Corporate Author Or Publisher: USASDC, Huntsville, AL; LTV Aerospace & Defense Co., Dallas, TX
Report Number: AIAA 92-2750

Comments on Document: AIAA SDIO Annual Interceptor Technology Conference, Huntsville, AL

Descriptors, Keywords: ERINT-1 Missile Interceptor Flight Radar MFC Lethality Solid Rocket Booster Launch

Pages: 00006

Cataloged Date: Jan 27, 1993

Document Type: HC

Number of Copies In Library: 000001

Record ID: 26113

Source of Document: AIAA

SUBSYSTEMS FOR THE EXTENDED RANGE INTERCEPTOR (ERINT-1) MISSILE

Ronald D. Herman
 Director, Program Operations
 ERINT-1 Program
 LTV Aerospace & Defense Company
 Missiles Division

Joseph H. Butler
 ERINT-1 Program Manager
 U. S. Army Strategic
 Defense Command

Abstract

This paper describes the design and performance of the subsystems being developed and flight tested for the ERINT-1 Missile. The ERINT-1 Program, sponsored by the U.S. Army Strategic Defense Command, consists of the design and flight test of a prototype missile and launch control system for defense against ballistic and maneuvering tactical missiles and aircraft and cruise missiles. The ERINT-1 Missile also has capability against air-breathing aircraft and cruise missiles.

The technologies demonstrated by the Flexible, Lightweight, Agile, Guided Experiment (FLAGE) Program and previous ERINT Programs were utilized by the ERINT-1 Program. The performance of the missile is increased to provide intercept capability at higher altitudes and longer ranges than was previously demonstrated by FLAGE. The missile components are redesigned in order to provide packaging commensurate with the small, lightweight, agile missile concept while increasing missile performance.

This paper discusses the design, operation, and capability of each of the missile subsystems and those elements of the Launch Control System which have been developed for the Flight Test Program.

Program Overview

The ERINT-1 Program is sponsored by the U. S. Army Strategic Defense Command. The objective of the Extended Range Interceptor (ERINT-1) Program is to develop and demonstrate a prototype missile and launch control system for tactical missile (TM) defense. The missile and launch control system is compatible with the fire control radars, the command and control systems, and the anti-aircraft missile systems currently existing and those planned for the contingency theater in the 1990's. The Flight Test Program will demonstrate missile ballistic and maneuvering tactical missiles and air-breathing targets in a flight test program at the White Sands Missile Range.

The decisive advantage that the ERINT-1 missile offers for TM defense is guidance accuracy and system response sufficient to effect body-to-body impact for hard kill of TM warheads. The requirements to achieve hit-to-kill of TM targets flows down to all aspects of the missile system design. The combination of these features is illustrated in Figure 1. Achieving a high probability of warhead kill imposes design requirements for an accurate seeker, an agile missile airframe, and effective maneuvering system

and a high speed missile. Specifically, the missile must have a maneuvering system capable of instantaneous response to information gathered through the seeker's highly accurate tracking mode in order to reduce homing errors. Additionally, hard kill of the most severe threat warheads requires that the maximum kinetic be delivered on the threat warhead. The seeker must accurately map the entire target to identify an aimpoint on the warhead section. The unique combination of technologies in the ERINT-1 Design allows this refinement of the aimpoint, thus maximizing the kinetic energy impact on the warhead to assure hard kill.

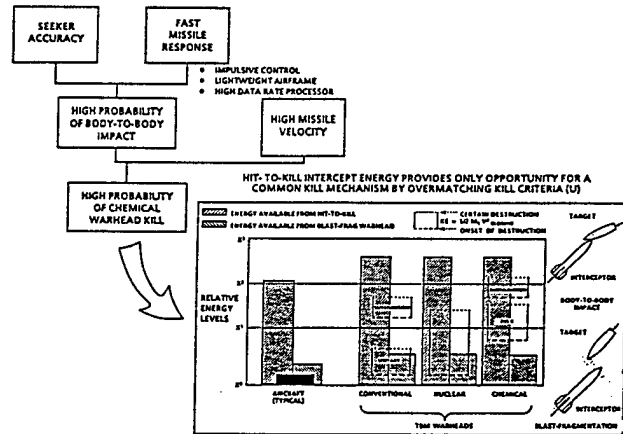

FIGURE 1. ERINT-1 SOLUTION TO THE TACTICAL MISSILE PROBLEM

Characteristics of an ERINT-1 missile flight are illustrated in Figure 2. Following launch, the missile is inertially guided to the target acquisition point. During this flyout phase, the missile uses the aerodynamic control surfaces for pitch, roll, and yaw control. Target position updates may occur (as required) during this phase. Prior to target acquisition, the radome cover is ejected and the radar antenna is pointed to center the combined target error volume in the center of the seeker field of view. After the target is acquired, the guidance process begins using the radar seeker data for homing phase guidance and small, solid propellant attitude control motors for pitch and yaw control. Prior to target intercept, the Lethality Enhancer is fired based on the seeker range information. The missile will

operate in the low to mid-end atmospheric region and will be effective in fog, rain, snow and the anticipated countermeasure environments.

Radar Seeker

The ERINT-1 Radar Seeker characteristics are shown in Figure 5. The ERINT-1 Radar Seeker is a range- and angle-tracking, active Ka-Band Doppler radar use during the terminal phase of the mission. The design and architecture is based on two target situations; a tactical missile having a small Radar Cross Section (RCS) with high velocity and an air breathing threat having larger RCS but lower velocity. The Radar Seeker features a continuous track, 2 axis monopulse antenna, supported by a gimbal system which provides an effective stabilized antenna platform carefully balanced to ensure maximum isolation of the stabilized antenna from missile body motion. It is capable of operation in the high acceleration environment of the missile boost phase and under the high maneuver accelerations expected during the engagement. Fully autonomous identification of the target and its discrimination based on Doppler shift differential is provided. The signal receiver provides multiple stages of down conversion followed by digital sampling of the final IF amplifier output which achieves at least 50 KHz total signal processing bandwidth. The IF Processor employs lightweight modular design using state of the art electronics components. The system mechanical design features replaceable modularizable functions. The Radar Seeker assembly consists of the radome with its deployable cover and release mechanism, the antenna, the three channel microwave receiver, the Gimbal mechanism and associated electronics, the IF Processor, Digital Processor, Traveling Wave Tube Power Amplifier/Modulator/Power Supply, the Master Frequency Generator and the Low Voltage Power Supply.

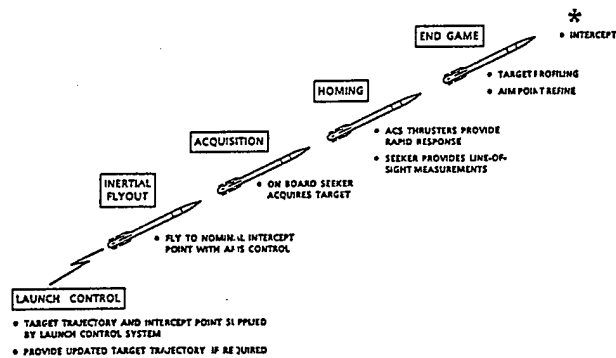
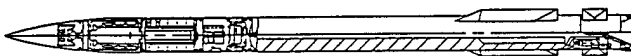

FIGURE 2. ERINT-1 MISSILE FLIGHT CHARACTERISTICS

Missile Configuration and Subsystems

The ERINT-1 missile, Figure 3 is 255 mm in diameter and 4635 mm long with a launch mass of 304 kg and a burnout mass of 140 kg. The small lightweight missile provides high fire power at the launch site. Distinctive features of the external configuration are the forward located Attitude Control Section and the aft located tandem Maneuvering System arrangement consisting of fixed fins followed by aerodynamic control surfaces.



DIAMETER: 255mm (10 IN.)
LENGTH: 4635mm (182.5 IN.)

LAUNCH WEIGHT: 304 Kg (670 LB)
BURNOUT WEIGHT: 140 Kg (308 LB)

FIGURE 3. ERINT-1 MISSILE

Each of the missile subsystems and their major components are illustrated in Figure 4 and described in the following paragraphs.

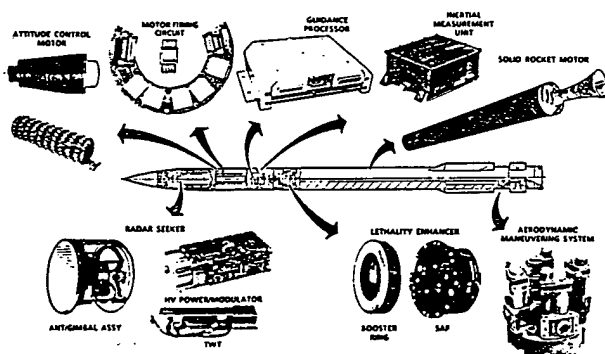
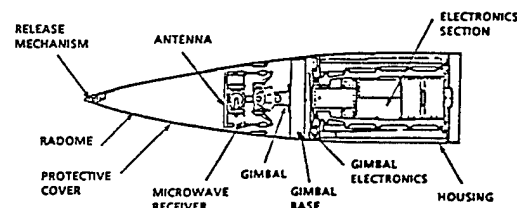

FIGURE 4. ERINT-1 MISSILE SUBSYSTEMS



- ACTIVE Ka-BAND, PULSE DOPPLER RADAR
- 45-DEGREE CONICAL FIELD OF REGARD
- NARROW BEAMWIDTH MONOPULSE ANTENNA
- LOW NOISE FIGURE RECEIVER
- 200 Hz RADAR/MISSILE DATA RATE
- WEIGHT 27.3 kg, LENGTH 1,040 mm

FIGURE 5. RADAR SEEKER

Attitude Control Motors

The ERINT-1 missile uses an array of small, radially positioned, rapid firing, solid propellant motors for terminal agility. The Attitude Control Section (ACS) for the ERINT-1 missile is illustrated in Figure 6. The ACS contains 180 solid propellant Attitude Control Motors (ACMs) that thrust perpendicular to the centerline of the missile to provide pitch and yaw control during the homing phase. The ACMs are spaced evenly around the centerline of the missile in rings containing 18 motors. There are 10 rings in the ACS in the longitudinal direction for a total of 180 motors. The ACMs are commanded by the Motor Fire Circuit (MFC). The MFC is fabricated on flexprint and encapsulated within the inner core of the ACS. The impulse of the ERINT-1 ACM is 51.15 N-S (11.5 lb-sec) with a maximum thrust of 6000 N (1350 lbs).

A cross section of the ERINT-1 ACM is also illustrated in Figure 6. The propellant for the ERINT-1 ACM is the same as the FLAGE ACM, but the amount is increased and the motor case is graphite/epoxy instead of titanium to reduce motor weight and production costs. The motor is fabricated by casting the propellant in an aluminum motor cone and winding the graphite/epoxy composite around the motor cone.

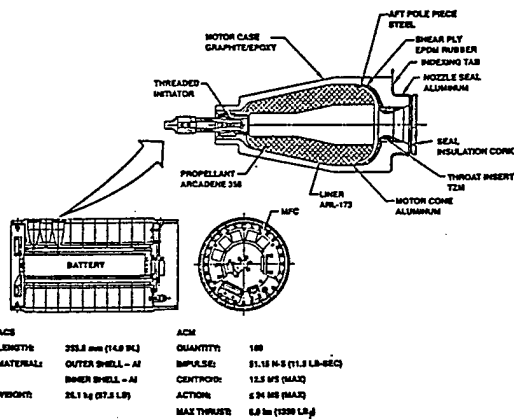

FIGURE 6. ATTITUDE CONTROL SECTION

Motor Firing Circuit

The Motor Firing Circuit (MFC) provides firing current to the ACMs in response to the digital level signal originating in the Guidance Processor Unit (GPU). The MFC consists of a circuit card mounted on the aft bulkhead of the ACS and a flex circuit which is wrapped around the inner core of the ACS. The dual pins located on each ACM initiator connect with the flexprint circuit via a dual socket at each ACM location.

Mid Section Guidance Assembly

The Mid Section Assembly of the missile houses the Guidance Assembly (Guidance Processor Unit and the Inertial Measurement Unit) and the Lethality Enhancer. The Guidance Processor Unit (GPU) is a small, lightweight, high-throughput microprocessor based computer which functions as the central data processor in the ERINT-1 missile, Figure 7. The GPU consists of the Motorola 68020 32-bit microprocessor in combination with the 68881 floating-point coprocessor. In addition, the central processor includes a special configuration floating point unit capable of high-speed, single-precision multiplication and addition/subtraction. Most of the input/output (I/O) logic functions are contained in the I/O Application Specific Integrated Circuit (ASIC) implemented in CMOS gate array technology.

Inertial Measurement Unit

The Inertial Measurement Unit (IMU) senses vehicle angular rates and linear accelerations in a body mounted, strap down mode and provides compensated three axis angle increment and three axis linear velocity increment data in digital format. The IMU contains a triad of angular rate sensors, a triad of linear accelerometers, and necessary sensor processing electronics, Built-in-Test (BIT) circuitry and other components necessary for implementation. Significant characteristics of the IMU are indicated in Figure 7.

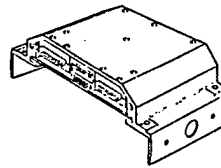

GUIDANCE PROCESSOR UNIT CHARACTERISTICS

VOLUME:	1219 cc (74 CUBIC IN.)
WEIGHT:	1.6 Kg (3.5 LB)
MEMORY:	272 KB
THROUGHPUT:	1.9 MIPs

INERTIAL MEASUREMENT UNIT CHARACTERISTICS

VOLUME:	2100 cc (128 CUBIC IN.)
WEIGHT:	2.7 Kg (6.0 LB)
GYRO RATE RANGE:	1620°/SEC
GYRO RATE BIAS:	2°/HR
ACCELEROMETER RANGE:	+65g
ACCELEROMETER BIAS:	± 500µg

FIGURE 7. MID SECTION GUIDANCE ASSEMBLY

Lethality Enhancer

A Lethality Enhancer (LE) is included in the ERINT-1 missile to increase the effective missile diameter for kinetic energy kill of the target. The LE was designed, fabricated and tested to verify performance by means of arena tests and high-speed rocket sled tests during the previous ERINT technology demonstrations. The LE concept shown in Figure 8 uses twenty-four 214 gram fragments that deploy around the centerline of the missile at low radial velocities, forming concentric rings of fragments with the missile at the center. These rings effectively increase the missile diameter so that the target will be hit by either the missile or the fragments. A major advantage of the low-expansion velocity fragment concept is the reduced sensitivity of the fragment pattern to the error in fuze time. This enables the processed Radar Seeker range information to be sufficiently accurate to determine the time to detonate the explosive in the LE, which imparts the velocity to the fragments. The dual Safe Arm Fuze (SAF) for the LE also performs the SAF functions for the Flight Termination System.

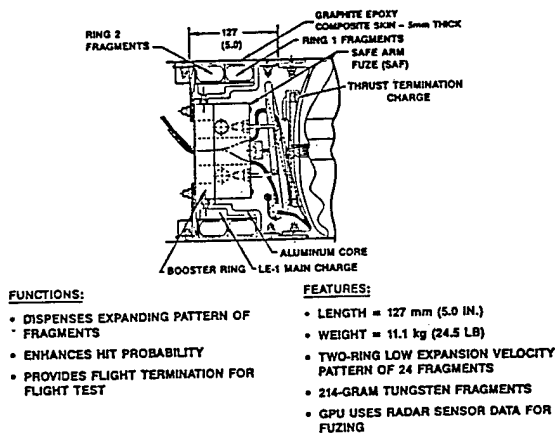

FIGURE 8. LETHALITY ENHANCER

Solid Rocket Motor

A boost-sustain Solid Rocket Motor (SRM) is used by the ERINT-1 missile to achieve the velocity. A high mass fraction SRM, using a graphite/epoxy component case providing high performance and low weight, has been selected for ERINT-1. The SRM, as shown in Figure 9, is 255 mm in diameter and has integral fin attachment lugs and integral forward and aft skirts.

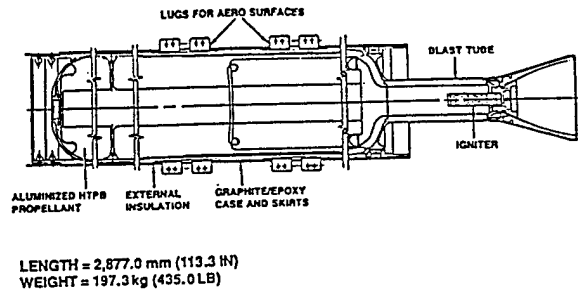
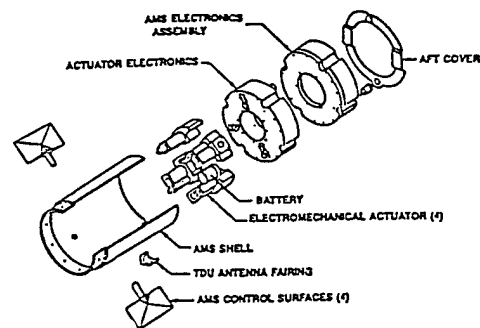

FIGURE 9. SOLID ROCKET MOTOR

Aerodynamic Maneuvering System

The Aerodynamic Maneuvering System (AMS) section of the missile houses the SRM blast tube/nozzle, the Target Data Uplink System, and the AMS. The AMS consists of 4 aerodynamic control surfaces, 4 electromechanical actuators, AMS electronics assembly, control electronics unit, and battery. The AMS, illustrated in Figure 10, provides pitch, roll, and yaw control during the flyout phase of the mission and roll control during the homing phase.



- Provides MSL pitch and yaw control in flyout
- Provides roll control in all phases

FIGURE 10. AERODYNAMIC MANEUVERING SYSTEM

Target Data Uplink

The Target Data Uplink (TDU) system is integrally packaged with the AMS electronics and consists of an antenna receiver, as shown in Figure 11. The antenna-receiver receives uplink messages providing inflight target data over an RF link and provides signal conditioning and demodulation. Resultant data and timing is supplied to the missile guidance processor. Downlink capability from the missile to the ground is not required for missile operation.

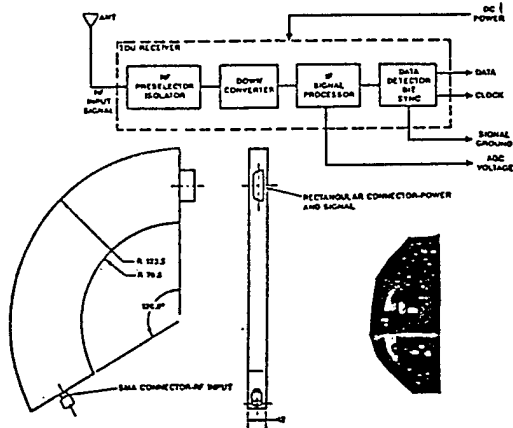

FIGURE 11. TARGET DATA UPLINK SYSTEM

Launch and Update Control System

The ERINT-1 Launch and Update Control System (LUCS) is a modification and further development of the LUCS concept successfully demonstrated on the FLAGE program. The resulting LUCS contains all the requisite elements and functionally emulates the system needed for an operational system. One of the test program objectives is to demonstrate the LUCS functions and show that the LUCS applies to the operational system, except for higher echelon command, control and communications elements.

The LUCS provides missile preflight readiness checkout, predicts target fight parameters for loading into the missile prior to launch, initiates the Launch Control Unit (LCU) Autoinitiate countdown, provides initialization of the IMU, and commands the battery firings and missile launch. The LUCS performs these functions by integration/interfacing the following equipment: the Fire Control Computer (FCC), the LCU, the Remote Power and Simulator (RPS), the Target Track Radars (TTRs), the Ground Station Unit (GSU) and WSMR interfaces. Five software programs control the hardware elements and Range interfaces: Fire Control Computer Program (FCCP) in the FCC, Launch Control Computer Program (LCCP) in the LCU,

Ground Station Computer Program (GSCP) in the GSU, MUX Monitor Computer Program (MMCP) in the LCU, and I/O Computer Program IOCP in the FCC. The LUCS is illustrated in Figure 12.

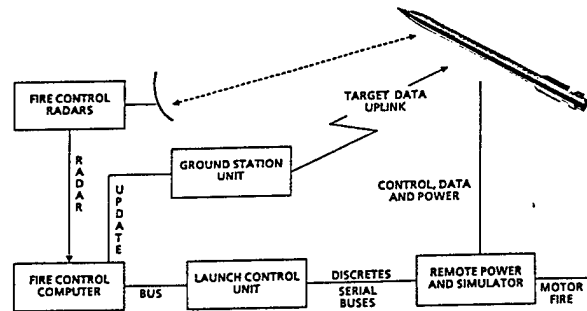

FIGURE 12. LAUNCH AND UPDATE CONTROL SYSTEM

Launch Control Unit

The Launch Control Unit (LCU) commands power to the missile, through the RPS; monitors the power and other control circuits, loads GPU and Seeker software; performs self-test functions; and controls the Autoinitial phase of the countdown.

The LCU is a rack mounted Multibus I based system containing a MC68020 CPU board running at 16 MHz with 4 M byte of memory and under control of the OS-9 operating system. This board is capable of interfacing four RS-232 pieces of equipment and controlling the 40 M byte hard disk drive and the floppy disk drive. The LCU is controlled through a CRT and keyboard terminal and output is recorded on printer. The LCU communicates with the RPS through a land line, and to the missile through the MIL-STD 1553 bus. There is a Safe/Arm key switch and light indicators on the LCU control panel.

Fire Control Computer

The Fire Control Computer (FCC) processes the target tracking data from the fire control radars through the WSMR interfaces and transfers the target parameters to the missile GPU before launch. After launch the target continues to be tracked and the data is processed by the FCC to produce an update if needed. The FCC will process both WSMR track data as well as operational radar track data. The FCC communicates with the LCU to control the launch timeline and with the GSU to transmit an update.

The FCC for the ERINT-1 missions is a VME based computer system. The VME backplane contains two CPU boards, one to accept target track data from fire control radars and WSMR radars (I/O CPU Board), and one to calculate the intercept solution and control the mission logic and time line. The radar interface consist of eight synchronous 2400 BAUD RS-232 interfaces. The interface to the LCU is over an RS-232 link. The interface with the GSU is fiber optic. The FCC will communicate with the Missile/GPU by transmitting via the RS-232 link to the LCU, then the LCU transmits the message via the 1553B bus to the missile GPU.

The software for the FCC is the FCCP. The major functions of the FCCP are to accept and filter target track data, compute the intercept solution, calculate the target parameters and transmit them to the missile, compute the TDU data and transmit the data to the GSU transmitter.

Ground Station Unit

The ERINT-1 missile is designed to operate at typical tactical missile intercept altitudes. The target parameters preloaded into the missile prior to launch are based on data from the LUCS, which estimates the target states and projects them ahead in time to the predicted intercept point. On high altitude missions or in maneuvering target engagement, significant differences between the true trajectory states and the projected trajectory states can occur. This reduces the probability of target acquisition by the missile Radar Seeker or causes large homing guidance maneuvers. The ERINT-1 system avoids this situation by continuing to track and filter the target data with the FCC after the ERINT-1 missile is launched. The GSU, in conjunction with the TDU, form the uplink capability needed for high altitude or maneuvering target intercepts.

ERINT-1 Subsystem Technology Improvements/Development

Development of the ERINT-1 missile has resulted in a number of advanced technology improvements and developments. A partial list of these improvements/developments are presented below:

- o Ka-band active radar seeker, featuring:
 - High-power transmitter/TWT
 - Low-noise receiver
 - Large gimbal angle capability
 - Range measurements
 - Capability in ECM environment
- o Large bandwidth frequency agility
- o Narrow beam acquisition and track
- o Home on jam
- o High-performance, lightweight impulsive control motors provide rapid missile rapid missile response for hit-to-kill lethality in aircraft and missile defense applications.
- o Advanced state-of-the-art, high-speed, lightweight guidance processor
- o Small, lightweight inertial measurement unit provides fire and forget capability
- o Lethality Enhancer, featuring:
 - Low-expansion-velocity fragment pattern
 - Simplified fuzing using radar seeker measurements

- Large fragments for high kinetic energy
- o High-performance, composite case solid rocket motor
 - 84% mass fraction
 - Integral titanium fin lugs
- o Lightweight, high-performance aerodynamic maneuvering system, featuring:
 - Large maneuver capability
 - Electromechanical actuators
 - Digital control
- o Launch control and update system, featuring:
 - Algorithms for target intercept prediction
 - Update features for refreshing target information

Summary

The ERINT-1 missile is a unique tactical missile defense system which provides the capability of a hard kill against tactical missile warheads. The concepts implemented are based on previous demonstrations in the FLAGE and ERINT technology development programs. An eight flight test program is scheduled to begin in the Spring of 1992 and activity is ongoing to integrate the ERINT-1 missile and LUCS into the PATRIOT Air Defense System.