

PL-TR-97-2101

HAARP IMAGING RIOMETER DIAGNOSTIC

Dr. T.J. Rosenberg

Advanced Power Technologies, Inc.
1250 Twenty-Fourth St., NW
Washington, DC 20037

16 July 1997

Final Report
17 September 1991 – 31 December 1997

Approved for public release; distribution unlimited

19980511 161



PHILLIPS LABORATORY
Directorate of Geophysics
AIR FORCE MATERIEL COMMAND
HANSCOM AFB, MA 01731-3010

"This technical report has been reviewed and is approved for publication."



JOHN L. HECKSCHER
Contract Manager

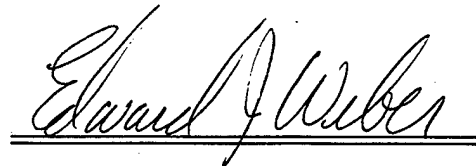

EDWARD J. WEBER, Chief
Ionospheric Applications Branch

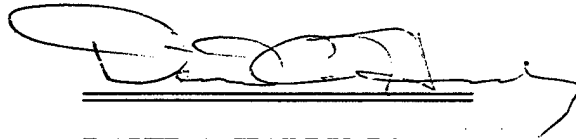

DAVID A. HARDY, Director
Space Effects Division

This report has been reviewed by the ESC Public Affairs Office (PA) and is releasable to the National Technical Information Service (NTIS).

Qualified requestors may obtain additional copies from the Defense Technical Information Center (DTIC). All others should apply to the National Technical Information Service (NTIS).

If your address has changed, or if you wish to be removed from the mailing list, or if the addressee is no longer employed by your organization, please notify PL/TSI, 29 Randolph Road, Hanscom AFB, MA 01731-3010. This will assist us in maintaining a current mailing list.

Do not return copies of this report unless contractual obligations or notices on a specific document require that it be returned.

REPORT DOCUMENTATION PAGE

Form Approved
OMB No. 0704-0188

Public reporting burden for this collection of information is estimated to average 1 hour per response, including the time for reviewing instructions, searching existing data sources, gathering and maintaining the data needed, and completing and reviewing the collection of information. Send comments regarding this burden estimate or any other aspect of this collection of information, including suggestions for reducing this burden, to Washington Headquarters Services, Directorate for Information Operations and Reports, 1215 Jefferson Davis Highway, Suite 1204, Arlington, VA 22202-4302, and to the Office of Management and Budget, Paperwork Reduction Project (0704-0188), Washington, DC 20503.

1. AGENCY USE ONLY (Leave blank)	2. REPORT DATE 16 July 1997	3. REPORT TYPE AND DATES COVERED Final 9/17/91 - 12/31/97
---	---------------------------------------	---

4. TITLE AND SUBTITLE HAARP Imaging Riometer Diagnostic	5. FUNDING NUMBERS PE 61107D PR 4029 TA 01 WU AF
---	---

6. AUTHOR(S) Dr. Ted Rosenberg	Contract F19628-91-C-0158
--	---------------------------

7. PERFORMING ORGANIZATION NAME(S) AND ADDRESS(ES) Advanced Power Technologies, Inc. 1250 24 th Street, NW Washington, DC 20037	8. PERFORMING ORGANIZATION REPORT NUMBER
--	---

9. SPONSORING / MONITORING AGENCY NAME(S) AND ADDRESS(ES) Phillips Laboratory 29 Randolph Road Hanscom AFB, MA 01731-3010 Contract Manager: John Heckscher/GPSI	10. SPONSORING / MONITORING AGENCY REPORT NUMBER PL-TR-97-2101
--	--

11. SUPPLEMENTARY NOTES

12a. DISTRIBUTION / AVAILABILITY STATEMENT Approved for public release; distribution unlimited	12b. DISTRIBUTION CODE
--	-------------------------------

13. ABSTRACT (Maximum 200 words)

This report describes the prototype 16-beam, 38.6 MHz riometer system developed by APTI and the University of Maryland for the HAARP program. The prototype system is the forerunner for a full-scale imaging riometer diagnostic instrument for characterizing the ionospheric volume perturbed by controlled RF heating experiments. The prototype system, installed at the HAARP site near Gakona, AK, consists of a 1 x 16 antenna array phased in one dimension (beam width of 6.7°) and oriented approximately along the magnetic meridian. The system responds sensitively to natural variations or auroral absorption, such as those caused by magnetospheric substorms, and provides clear evidence of its capability to discern spatial structure and motion. A newly observed feature seen near dusk are intense, short-duration absorption spikes accompanied by only weak magnetic signatures. The proximity of the prototype system to the HAARP RF heater can result in significant interference to the riometer signal, making the data unusable at times. Detailed data comparisons have not yet been made with operations of the heater. However, the full-scale imaging capability of the proposed instrument, and a remote location, may be required to detect small-scale modifications of the ionosphere caused by the RF heater.

14. SUBJECT TERMS HAARP, ionospheric research instrument, roimeter diagnostic instrument, RF heating	15. NUMBER OF PAGES 20
	16. PRICE CODE

17. SECURITY CLASSIFICATION OF REPORT Unclassified	18. SECURITY CLASSIFICATION OF THIS PAGE Unclassified	19. SECURITY CLASSIFICATION OF ABSTRACT Unclassified	20. LIMITATION OF ABSTRACT SAR
--	---	--	--

CONTENTS

Introduction	1.
Proposed Instrumentation	2.
The Prototype HAARP Imaging Riometer System ...	4.
Observations	7.
Summary	12.
References	14.

Figure Captions

1. Schematic illustration of the use of an imaging riometer to measure the conductivity modification within a heated region.
2. Ionospheric projection of the proposed 256-element antenna pattern showing the most central 164 beams. The dots show the position of maximum sensitivity within each beam. The inner and outer dashed circles represent 30° and 60° from the zenith, respectively.
3. A block diagram of the prototype HAARP imaging riometer system.
4. Ionospheric projection of the prototype 16-element HAARP riometer installed at Gakona, Alaska. The antenna array is phased only in the meridional direction, with the 16 beams numbered 1 (most northern) through 16 (most southern). Lines of constant magnetic invariant latitude 61° to 65° are indicated.
- 5a. Auroral absorption recorded through the eight north-pointing beams of the prototype array on March 14, 1995. Beam 1 is most inclined to the north while beam 8 is most nearly overhead (see Figure 4).
- 5b. Auroral absorption recorded through the eight south-pointing beams of the prototype array on March 14, 1995. Beam 9 is most nearly overhead while beam 16 is most inclined to the south (see Figure 4).
6. A "keogram"-style display of the latitude-time-intensity variations of auroral absorption for the data of Figure 5. The display ranges from north (beam 1) at the top to south (beam 16) at the bottom. The level of absorption in dB is given by the color bar. The spatially localized and broad absorption spikes near dusk, detailed in Figure 7, are highlighted by the arrows.
- 7a. A 4-hour plot (0200-0600 UT) in the same format as Figure 5a showing details of the absorption spike activity occurring near the dusk meridian on March 14, 1995 for the eight north-pointing beams.
- 7b. A 4-hour plot (0200-0600 UT) in the same format as Figure 5b showing details of the absorption spike activity occurring near the dusk meridian on March 14, 1995 for the eight south-pointing beams. Note that the sharp spike at 0310 UT is confirmed to the northern half of the array and that both spikes exhibit equatorward drift of the peak amplitudes.

Table Captions

1. Specifications of Prototype HAARP Riometer System

Introduction

A primary effect of radio frequency (RF) absorption in the D and lower E regions of the ionosphere is the modification of the conductivity of the irradiated layer. Nonlinear processes accompanying conductivity modulation can give rise to new wave energy at frequencies different from the modulation frequency. Much of the physics of these processes can be studied through controlled heating experiments using high power, high frequency (HF) transmitters.

The conductivity modification when an RF heater is on, followed by fast relaxation to its ambient value when the heater is off, is the basis of ULF/ELF/VLF wave generation (Stubbe et al., 1982; Papadopoulos et al., 1990). In the presence of the horizontal ionospheric electric field, which is perpendicular to the approximately vertical geomagnetic field at polar latitudes, the conductivity modulation induces a modulation of the Pedersen and Hall currents flowing through the perturbed region, thereby creating a virtual radiating antenna at the HF modulation frequency. The technique has been successful in generating electromagnetic waves spanning the range of ULF, VLF, and ELF frequencies.

One of the goals of HAARP (High-frequency Active Auroral Research Program) is to determine the efficiency of the scaling of HF power to ELF power, and to try to effect ways to increase it. The scaling depends on several key factors, e.g., the height-integrated Pedersen and Hall modulated conductivity, the modified area, and the vertical extent of the modified region. In order to obtain independent measurements of these factors, HAARP intends to support and operate a complementary diagnostic facility employing optical, magnetic, and radio wave instrumentation. The extensive set of scientific research instruments envisioned for this facility will also be valuable for observing naturally-occurring ionospheric and auroral processes when artificial heating experiments are not being conducted.

One of the instruments being considered for the HAARP diagnostic facility is an imaging riometer, based in part on the design described by Detrick and Rosenberg (1990). This report describes the prototype 16-beam riometer system, forerunner to a full-scale ale imaging riometer diagnostic array, developed by APTI and the University of Maryland and deployed at the HAARP site near Gakona, Alaska. Some examples of naturally-occurring ionospheric disturbances obtained with this prototype system will be presented. This material was first presented at the April 1995 Santa Fe High Power RF Ionospheric Modification Workshop.

Proposed instrumentation

The use of an imaging riometer, as illustrated in Figure 1, provides a diagnostic technique that has the potential to measure critical ionospheric heating parameters.

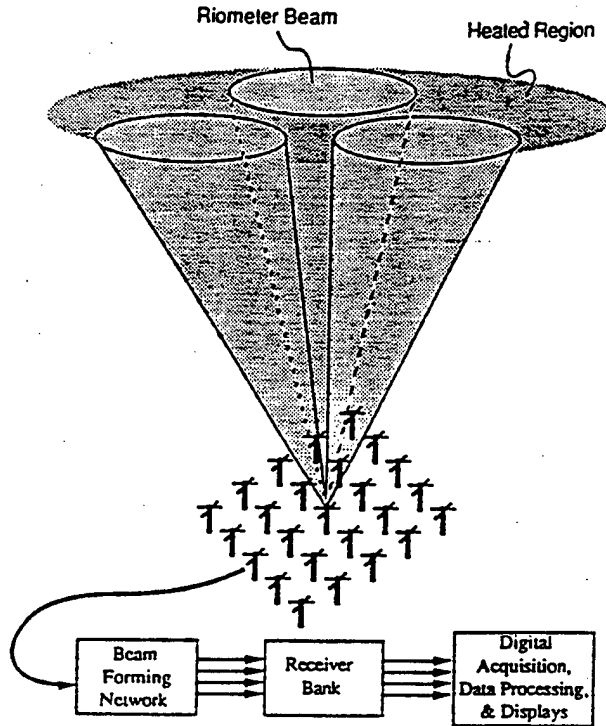

Figure 1. Schematic illustration of the use of an imaging riometer to measure the conductivity modification within a heated region.

As shown here, an imaging riometer consists of an array of independent receiving antennas, whose signals can be phased and combined to measure the background cosmic radiation at a specific frequency. The pointing capability and beam resolution of the phased array allow the riometer system to collect radiation incident from a conical region of the atmosphere. The level of conductivity modulation due to heating within this region can be deduced from the modulation in the received energy. Spatial resolution of the heated region can be achieved by forming multiple simultaneous beams, thus forming an image over the region of interest.

The HAARP Imaging Riometer Diagnostic, as originally proposed, would consist of a 256-element antenna array (16 x 16) and a Butler matrix phasing system (e.g., see Detrick and Rosenberg, 1990). Of the 256 beams possible with this design, it was proposed to use the central-most 164, covering an angular

view extending approximately 60° from the zenith. Figure 2 shows the projection of the antenna pattern onto a flat ionosphere at a height of 90 km above the surface, the approximate altitude where HF radiation from the HAARP transmitter is efficiently absorbed.

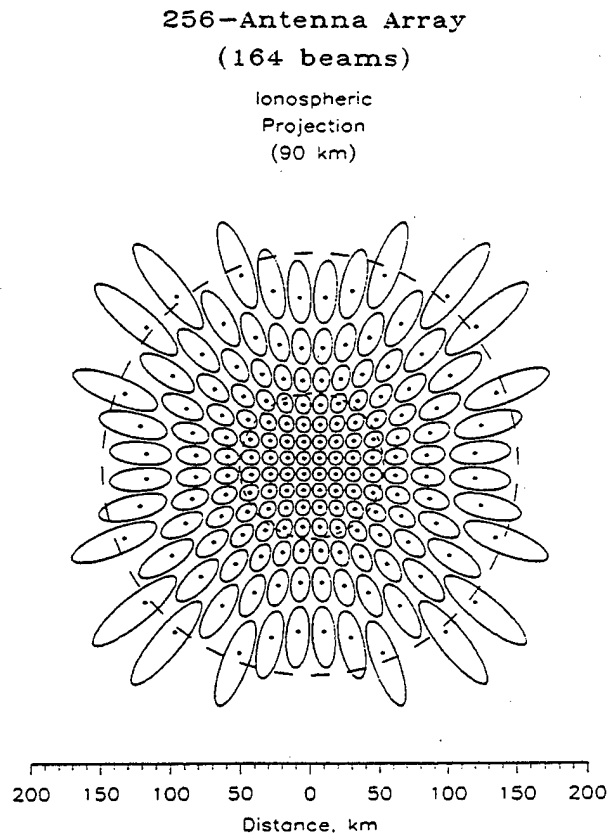

Figure 2. Ionospheric projection of the proposed 256-element antenna pattern showing the most central 164 beams. The dots show the position of maximum sensitivity within each beam. The inner and outer dashed circles represent 30° and 60° from the zenith, respectively.

The angular field-of-view (to the -3 dB locus) of an individual beam is approximately 6.7° , somewhat larger than the approximately 5° angular radiation pattern of the RF heater.

It is important to sample the heated volume rapidly and with high time resolution in order to follow the ionospheric response to the rapid rise and fall times of the heater pulses. To accomplish this, each of the 164 beam-forming outputs of the Butler matrix would be sampled by a dedicated fast-response receiver (operating at 38.6 MHz), specifically designed for the purpose. Several operating modes would be provided to obtain rapid continuous (1 ms) or synoptic

(0.1 ms) sampling of single beams or small clusters during heating experiments; at other times, the full array would be sampled continuously at lower resolution (1s).

With the funding provided to date, a prototype imaging riometer system, described in the next section, was designed, constructed and installed at Gakona, Alaska.

The prototype HAARP imaging riometer system

A functional block diagram of the system is shown in Figure 3.

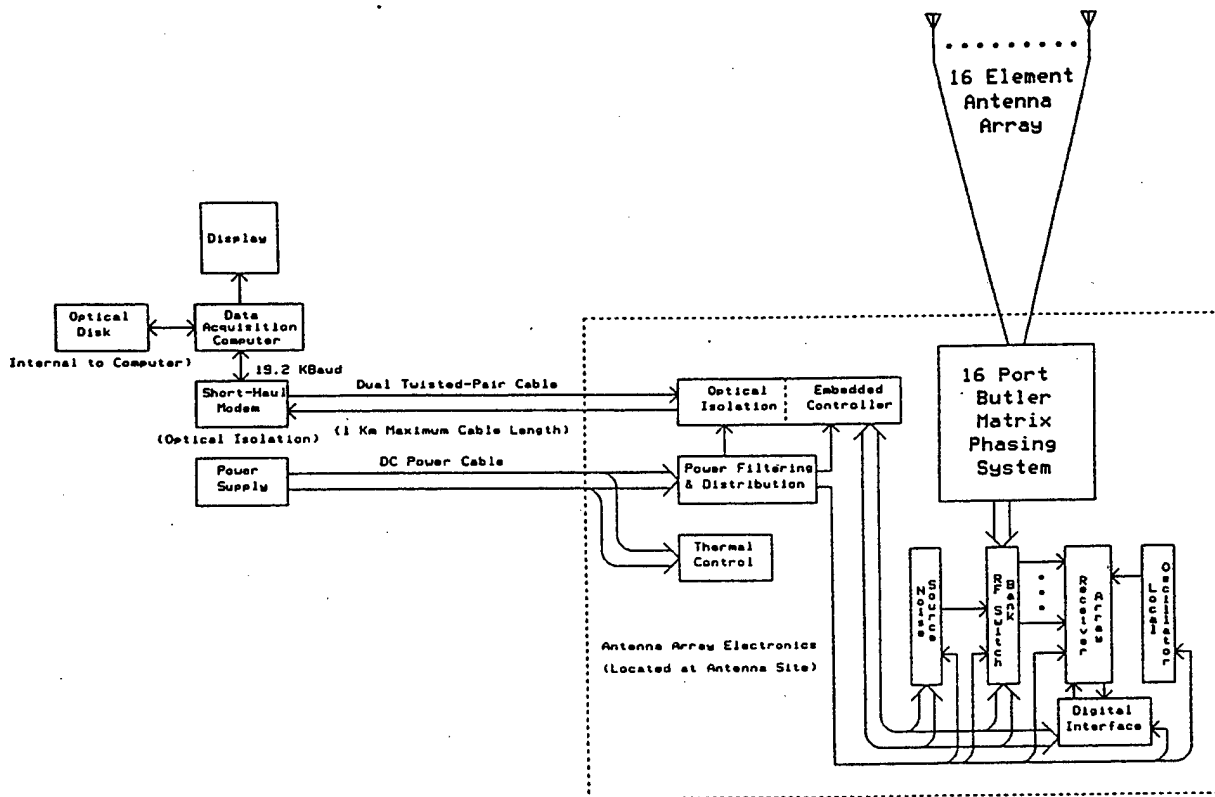

Figure 3. A Block diagram of the prototype HAARP imaging riometer system.

Table 1 provides a list of the system specifications.

Beam Pattern	1 x 16	
Beamwidth (@-3dB)	110° x 6.7°	
Phasing System Type	Butler Matrix	
Center Frequency	38.6 Mhz	
RF Bandwidth	1.0 Mhz	
A/D System	16 Bits (36 dB range)	
Data Storage Medium	Rewritable Optical Disk	
Internal Noise Calibration System		
Maximum Output	50,000 Kelvin	
Dynamic Range	29 dB (0.5 dB steps)	
Operational Modes		
1) Single Beam, 0.1 msec, Synoptic Sampling		
2) Single Beam, 1.0 msec, Continuous Sampling		
3) 16 Beams, 1 sec, Auto-calibrating		
Power Supply	100-130 VAC/60 Hz	
Power Consumption		
Standby Mode (Heater Power only)	100 Watts	
Operating Mode (All Power On)	400 Watts	
Ambient Temperature	Operating	Storage
Computer, Power Supply, Monitor	10°C-40°C	-20°C-60°C
All External Equipment	-70°C-35°C	-70°C-60°C
Humidity		
Computer, Power Supply, Monitor	20% - 80%	10% - 90%
All External Equipment	0% - 100%	0% - 100%

Table 1. Specifications of prototype HAARP imaging riometer system.

The imaging capability is obtained from a 16-element antenna array and a Butler matrix phasing system. Each of the 16 beam-forming outputs from the Butler matrix feeds an individual radio receiver tuned to 38.6 MHz. The receiver output voltage, which is proportional to the received power, is digitized for transmission to the data acquisition computer for display and recording. An RF switch assembly between the Butler matrix outputs and the receiver inputs permits calibrated noise levels to be input to the receivers so that the data can be calibrated against a reference.

The 16-port Butler matrix phasing system, the 16-receivers system, and the calibration system (consisting of a stable RF noise source, a precision programmable attenuator, and the RF switch assembly) are constructed as modular units. This will enable the full-scale HAARP imaging riometer

of the hardware and software can be found in the R&D Equipment Information Report (dated January 24, 1995), previously provided.

The 16-element antenna has been installed as a 1 x 16 linear array oriented in approximately a north-south magnetic direction. Figure 4 shows the projection onto a flat ionosphere at 90-km altitude of the antenna beam pattern (-3 dB contours) and the orientation of the beams with respect to the north geographic and geomagnetic poles.

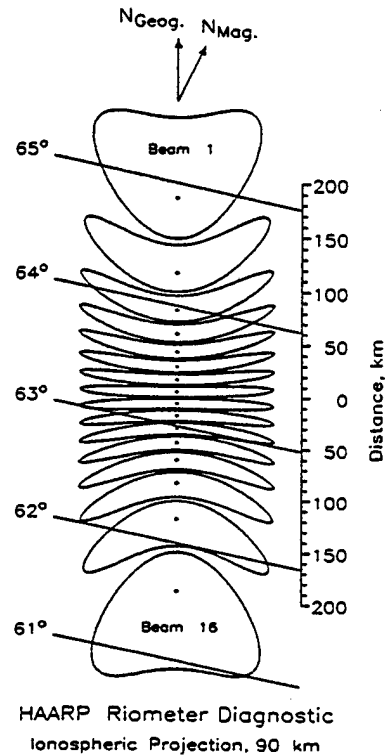

Figure 4. Ionospheric projection of the prototype 16-element HAARP riometer installed at Gakona, Alaska. The antenna array is phased only in the meridional direction, with the 16 beams numbered 1 (most northern) through 16 (most southern). Lines of constant magnetic invariant latitude 61° to 65° are indicated.

The straight lines labeled 61° through 65° are segments of contours of constant magnetic invariant latitude. The range of latitudes covered by the array permits an investigation of the subauroral region of the polar ionosphere.

Because the antenna is phased in one dimension (north-south) only, the prototype instrument is not a true imager, but it does offer a meridional view of ionospheric disturbances. The proximity of the riometer to the HAARP RF transmitter (it is only a few hundred yards away) often results in significant interference to the riometer signal, making the data unusable during some modes of heater operation. It is likely that a more remote location, as well as the full

interference to the riometer signal, making the data unusable during some modes of heater operation. It is likely that a more remote location, as well as the full imaging capability of the proposed instrument, will be needed in order to observe small-scale modifications of the ionosphere during heater operations. However, during off times of the heater, the riometer has provided high-quality continuous data on naturally-occurring auroral activity, including some surprising observations. An example is presented below.

Observations

Auroral absorption recorded by the 16-beam prototype HAARP imaging riometer on March 14, 1995 is shown in Figures 5a and 5b.

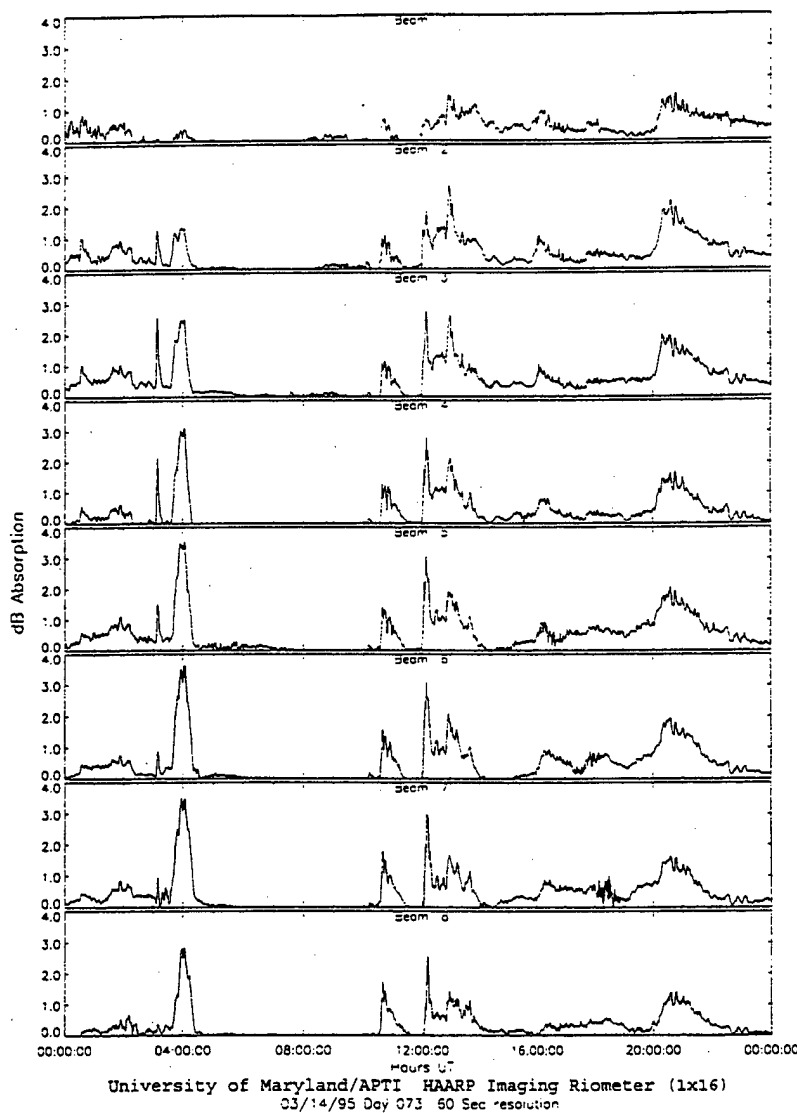

Figure 5a. Auroral absorption recorded through the eight north-pointing beams of the prototype array on March 14, 1995. Beam 1 is the most inclined to the north while beam 8 is most nearly overhead.

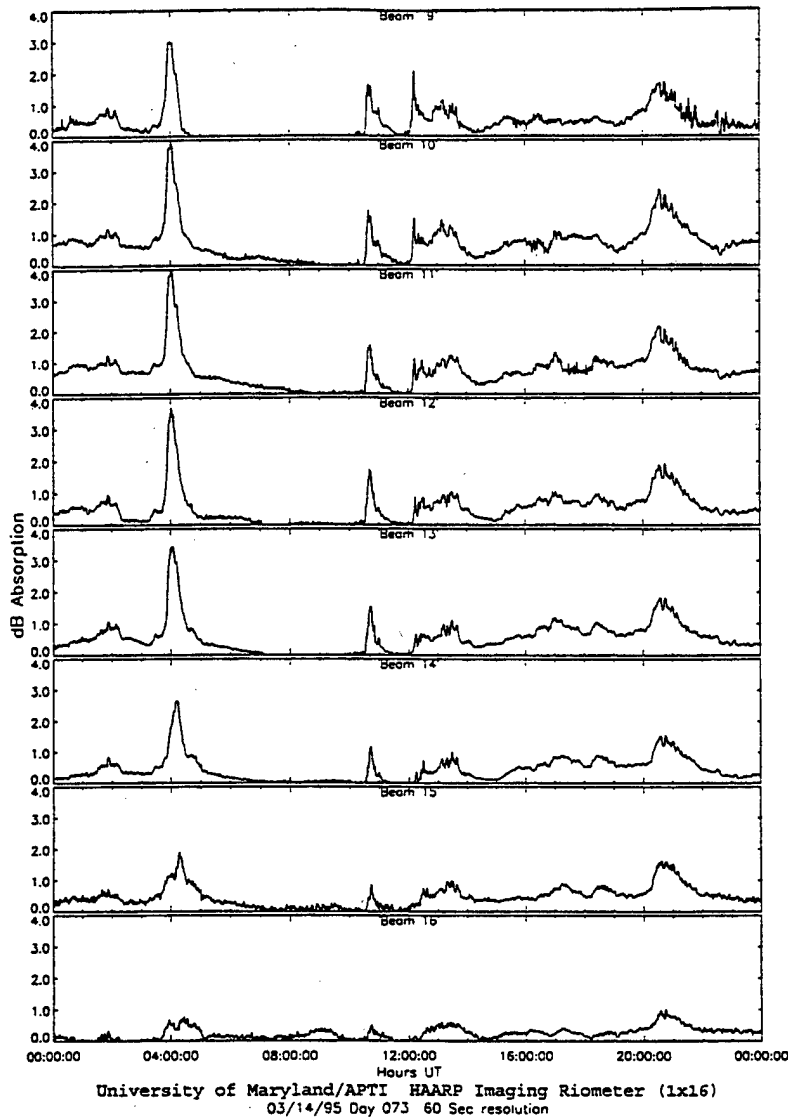

Figure 5b. Auroral absorption recorded through the eight south-pointing beams of the prototype array on March 14, 1995. Beam 9 is most nearly overhead while beam 16 is most inclined to the south.

The data is for the entire UT (Universal Time) day and is presented as decibels (dB) of absorption, that is, the amount of signal attenuation relative to the quiet (i.e., unperturbed) signal level expected at that sidereal time. Several weeks of data near the time of interest are used to calculate the reference quiet-day levels. Note that magnetic local time (MLT) for Gakona is $MLT = UT - 11$ hours. Thus, magnetic midnight at Gakona is approximately at the center of the plots. Each panel of Figure 5 corresponds to one of the 16 riometer beams. The beams are numbered from 1 (most poleward) through 16 (most equatorward), following the

University of Maryland/APTI HAARP Imaging Riometer (1 x 16)
03/14/95 Day 073 60 Sec Resolution

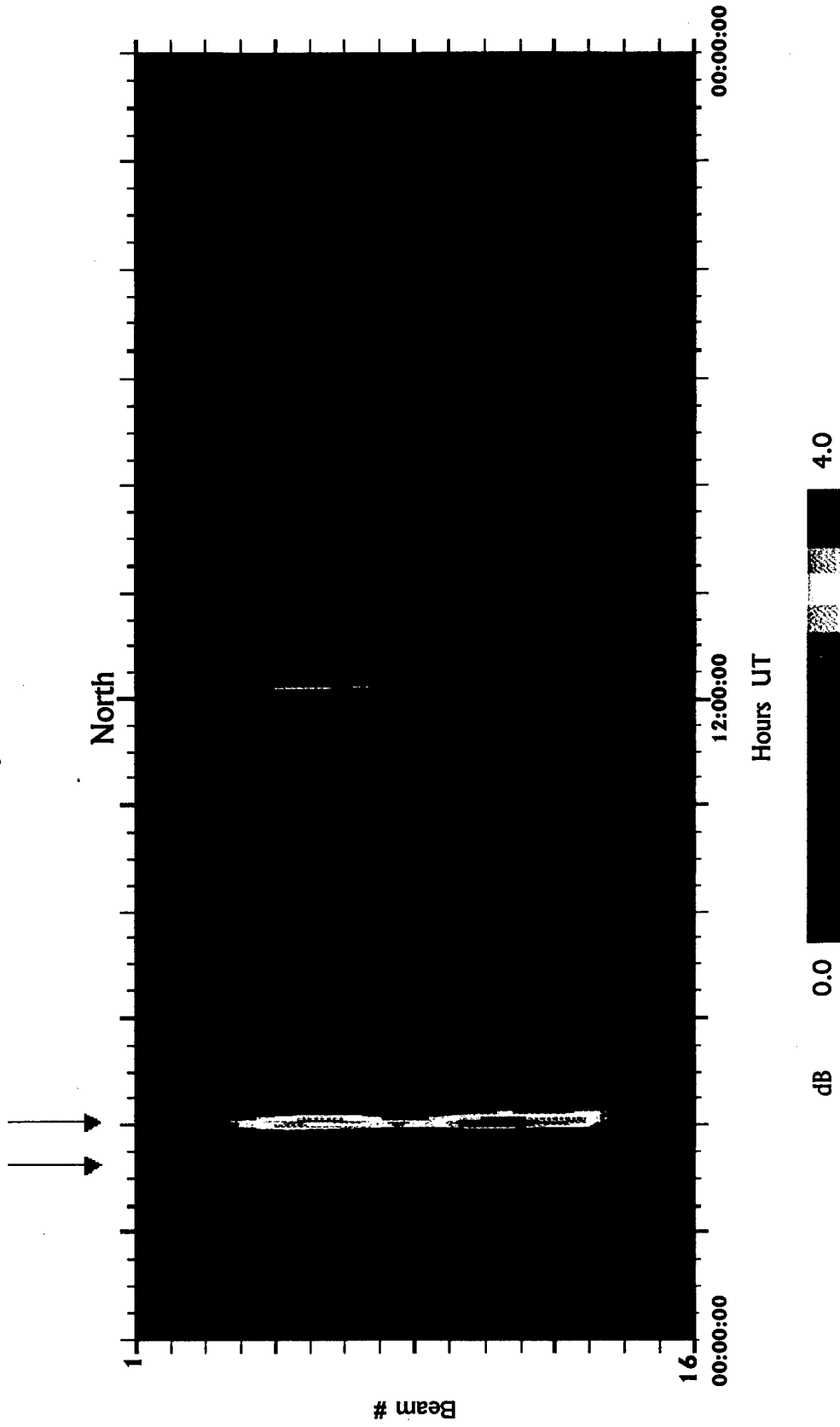

Figure 6

pattern depicted in Figure 4. Thus, Figure 5a (beams 1-8) covers an area from nearly overhead (beam 8) to the north, while Figure 5b (beams 9-16) covers an area from nearly overhead (beam 9) to the south. An alternative display of the latitude-time-intensity variations of Figure 5, in the "keogram" style analogous to a meridional slice through an optical all-sky camera, is presented in Figure 6 (illustrated on the previous page). In this figure, the ordinate is beam number (or latitude) with north (south) at the top (bottom), UT time is along the abscissa, and color as given by the bar is proportional to absorption in dB. Both the 16-beam and keogram data displays are archived daily and placed on our HAARP homepage at the University of Maryland (<http://www.polar.umd.edu/haarp/haarp.html>). In addition, specific science intervals in which HAARP data are used can be found on our primary web site (<http://www.polar.umd.edu>).

The absorption activity on March 14, 1995 typifies the range of activity often seen with this instrument, with the exception of the large, spiky enhancements occurring near 0400 UT. For example, the absorption between 1000 and 1400 UT (2300-0300 MLT) over the entire array, but diminishing in amplitude to the south, is commonly observed near midnight in association with magnetic substorms. The fast rise, slow decay absorption beginning near 2000 UT (0900 MLT) and lasting about two hours is referred to as a slowly-varying absorption event. This type of event is thought to be a dayside manifestation of nightside substorm activity, caused by the precipitation of eastward-drifting energetic electrons injected from the magnetotail into the nightside substorm source region.

While midnight and midday absorption are fairly common features, occurring on many days throughout a month, the large, spiky activity near 0400 UT (1700 MLT) close to the dusk meridian is much less common, occurring on only a few days of the month. These events are often characterized by large amplitudes (reaching as much as 6 dB) and short durations (as small as 5 minutes). They can be localized to only a portion of the riometer field of view as, for example, the sharp initial spike at 0310 UT (Figure 5a) seen only with beams 2-7, or cover a wider area, as for the broader spike at 0400 UT. These spike features appear to occur only within +/- 2 hours of the dusk meridian. The Gakona magnetometer shows only weak magnetic signatures, typically less than 100 nT variations in H or Z at the times of the spikes (J. V. Olson, personal communication).

Details of the spike activity on March 14, 1995 are shown with better time resolution in Figures 7a and 7b which cover the four hours from 0200-0600 UT in the same format as for Figure 5.

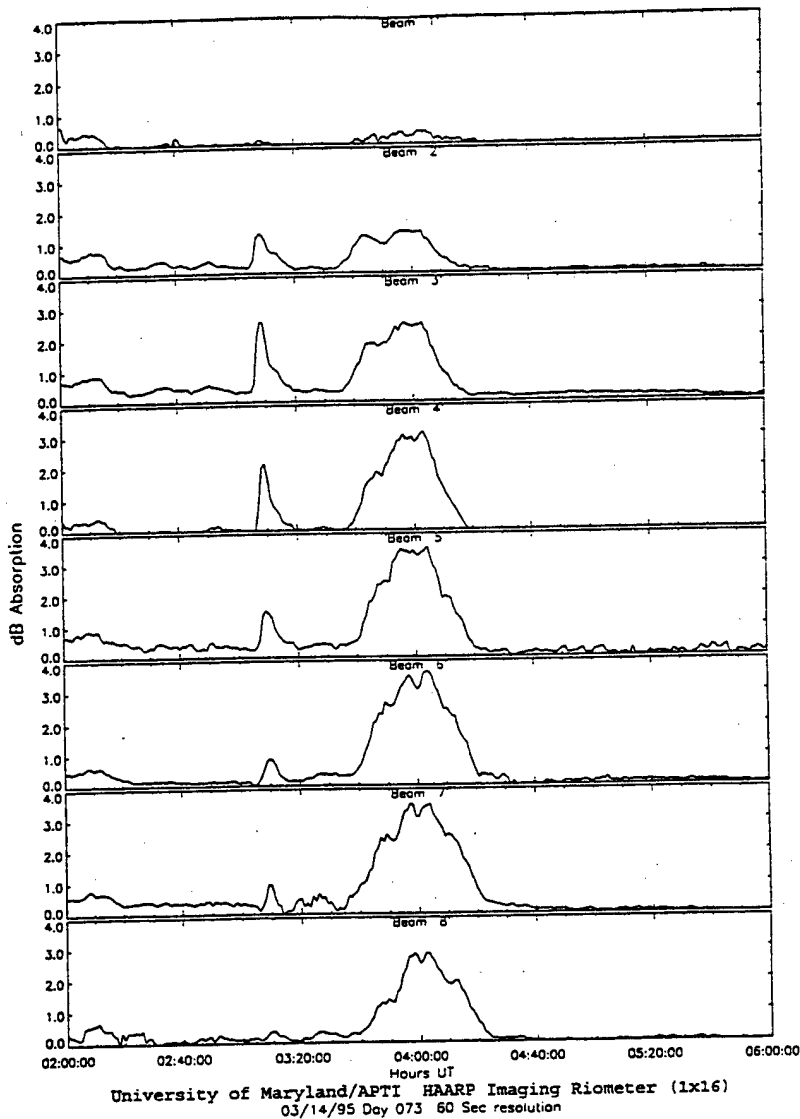

Figure 7a. A 4-hour plot (0200-0600UT) in the same format as Figure 5a showing details of the absorption spike activity occurring near the dusk meridian on March 14, 1995 for the eight north-pointing beams.

The two features at 0310 and 0400 UT show evidence of equatorward drift, that is, the peak amplitudes occur later in time as one moves further to the south. This is seen especially clearly for the latter peak in Figure 7b and is typical of the other duskside absorption spikes thus far examined. Such behavior could be interpreted as due to the equatorward drift of L-shell aligned auroral (absorption) arcs, although other geometrical configurations and motions may be possible. The one-dimensional nature of the present instrument limits further study of the spatial and temporal morphology of the spike phenomena.

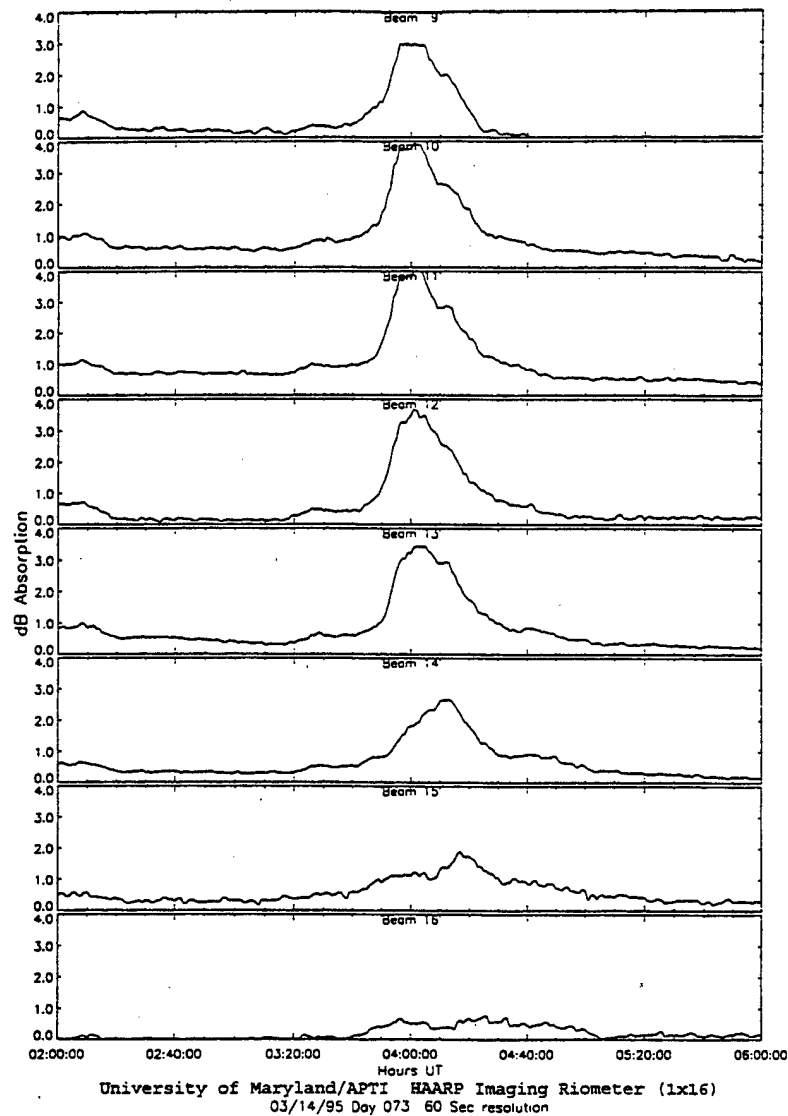

Figure 7b. A 4-hour plot (0200-0600 UT) in the same format as figure 5b showing details of the absorption spike activity occurring near the dusk meridian on March 14, 1995 for the eight south-pointing beams. Note that the sharp spike at 0310 UT is confined to the northern half of the array and that both spikes exhibit equatorward drift of the peak amplitudes.

Summary

Research into the aeronomical and plasma physical aspects of high power, high frequency ionospheric modification is the principal thrust of the HAARP program. One aspect of the modification process is the generation of new wave

energy at low frequencies. An extensive suite of ground-based diagnostic instruments for studying the modification and wave generation processes will complement the RF heating facility at Gakona, Alaska.

One of the instruments being considered for the diagnostic facility is an imaging riometer capable of examining the perturbed region with sufficient spatial and temporal resolution to aid in characterizing the ionospheric parameters that are critical for understanding and controlling the conversion of HF heater power to other forms. To realize the full potential of this instrument it should be located several miles from the heater site in order to minimize electromagnetic interference from the RF transmitters.

A prototype of the HAARP imaging riometer has been designed and deployed at the Gakona HAARP site. To date, it has been used mainly to observe the naturally-occurring auroral absorption activity prevalent at this site. Midnight and midday absorption events associated with magnetospheric substorms are common features at this subauroral location.

A new feature, intense, often localized, short-duration absorption spikes, occurring around the dusk meridian, has been encountered. The spatial and temporal morphology of these spikes, and their relationship to sub storm processes, are subjects of current study.

References

- Detrick, D. L., and T. J. Rosenberg, A phased-array radiowave imager for studies of cosmic noise absorption, *Radio Sci.*, 25, 325, 1990.
- Papadopoulos, K., C. L. Chang, P. Vitello, and A. Drobot, On the efficiency of ionospheric ELF generation, *Radio Sci.*, 25, 1311, 1990.
- Stubbe, P., H. Kopka, M. T. Reitveld, and R. L. Dowden, Ionospheric modification experiments in Northern Scandinavia, *J. Atmos. Terr. Phys.*, 44, 1025, 1982.