

JPRS-CST-92-003
19 FEBRUARY 1992

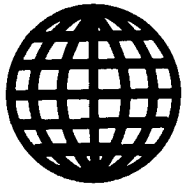

**FOREIGN
BROADCAST
INFORMATION
SERVICE**

JPRS Report

Science & Technology

China

19980512 113

DTIC QUALITY INSPECTED 3

DISTRIBUTION STATEMENT A

Approved for public release;
Distribution Unlimited

REPRODUCED BY
U.S. DEPARTMENT OF COMMERCE
NATIONAL TECHNICAL
INFORMATION SERVICE
SPRINGFIELD, VA 22161

SCIENCE & TECHNOLOGY
CHINA

CONTENTS

Aerospace

- LM-4 Launch Vehicle Control System
[Chen Baichu, Shen Tu Xinlin; ZHONGGUO HANGTIAN, Nov 91]..... 1

Lasers, Sensors, Optics

- New 10-GW Tunable Narrow-Linewidth Nd:Glass Laser Described
[Wu Hongxing, Guo Dahao, et al.; ZHONGGUO KEXUE, Aug 91]..... 8

Telecommunications R&D

- Domestic Multi-Function TVRO/VSAT Small Earth Stations Described
[Chen Zhaoji; DIANXIN KUAIBAO, Oct 91]..... 17
- Common Signaling TDMA Information Processing System Used for SCPC-DAMA
Satcom System
[Tang Jihua; DIANXIN KUAIBAO, Oct 91]..... 23

LM-4 Launch Vehicle Control System

92FE0211A Beijing ZHONGGUO HANGTIAN [AEROSPACE CHINA] in Chinese No 11, Nov 91 pp 10-13

[Article by Chen Baichu [7115 4102 0443] and Shen Tu Xinlin [3947 1458 2450 2651] of the Shanghai Space Automatic Control Equipment Design Institute: "Control System of LM-4 Launch Vehicle"]

[Text] Abstract

This paper gives a description of the components and performance of the LM-4 control system. In particular, three new technologies used in the control system are introduced: the digital attitude control system, the computer-controlled zero adjustment scheme, and the bi-directional swiveling [i.e., gimbaled] servomechanism. Flight-test results of the control system are also presented.

I. Introduction

The LM-4 is a three-stage launch vehicle which uses normal-temperature propellants. Its control system consists of the guidance system, the attitude control system, the control circuits and instruments, the test and launch control equipment, and the test and launch software. The system design has incorporated three new technologies: the digital attitude control system, the computer-controlled zero adjustment scheme, and the bi-directional swiveling servomechanism. The performance of the control system, which was completely designed and built by Chinese engineers, has been successfully demonstrated during the two flight tests of the LM-4 launch vehicle.

II. Control System

1. Guidance System

The guidance system has a platform-computer design. Its function is to control the flight trajectory of the launch vehicle, to issue engine cut-off commands for all the stages, and to issue lateral and normal guidance commands for the second and third stages for attitude control. The main components of the guidance system and the attitude control system include the three-axis

gyro-stabilized platform, the onboard computer, the rate gyro, the detection power amplifier and the servomechanism. Figure 1 shows a block diagram of the guidance system. In the figure, N_{cp} is the computer-generated program pulse which drives the program mechanism inside the platform to perform the vehicle's pitch turns; N_{cx} is the computer-generated program command pulse which drives the distributor to issue time-sequence commands during flight. W_x , W_y , and W_z are respectively, the output pulses from the three accelerometers inside the platform which indicate the apparent accelerations of the vehicle. These apparent acceleration pulses are integrated term-by-term in the computer and used in the engine cut-off equations to generate engine cut-off commands for the different stages and for the terminal-velocity correction engine. The accelerometer data are also used to derive the apparent velocities of the vehicle; differences between the computed apparent velocities and the velocities of the predetermined trajectory are used to form guidance commands for the pitch and yaw channels for attitude control. The guidance commands are generated based on linear control theory.

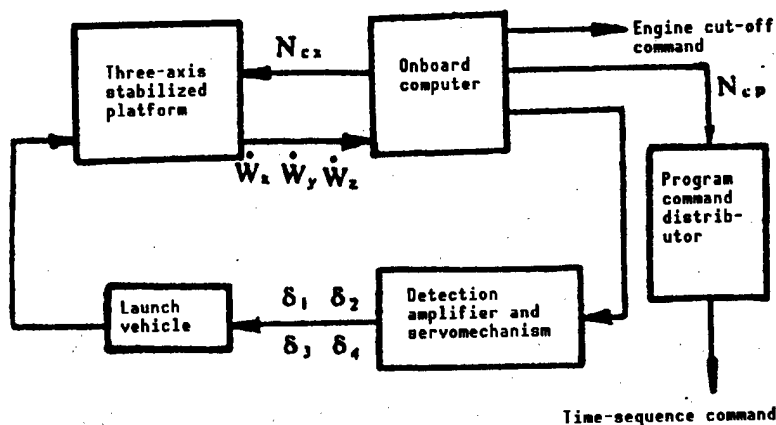

Figure 1. Block Diagram of the Guidance System

2. Digital Attitude Control System

Figure 2 shows a block diagram of the digital attitude control system. In the figure, ΔU_ϕ , U_ψ , and U_γ are respectively the vehicle pitch, yaw, and roll signals measured by the platform; U_ϕ^* , U_ψ^* , and U_γ^* are respectively the attitude angular velocity signals measured by the rate gyro; they are all 1 kHz a.c. carrier signals. The signals are converted by the detection filter into slowly varying d.c. signals and sent to the computer. After the process of multi-channel sampling and A/D conversion, they are synthesized with the guidance command signals; the synthesized signals are D/A converted by the computer and sent to the power amplifier. The amplified signals are then used to control the servomechanism which activates the steering engine. During the period between third-stage engine cut-off and satellite-rocket separation, the computer executes the switching-logic discrimination program, which activates the switching power amplifier to control the operation of the solenoid valve of the anhydrous-hydrazine engine.

Prior to rocket lift-off, the zero settings [i.e., null positions] of the attitude control system are indicated by the zero settings $U_{\delta 10} \sim U_{\delta 40}$ of the servomechanism outputs $U_{\delta 1} \sim U_{\delta 4}$. In the control system of the LM-4, the electromechanical-type zero-adjustment device used on previous models has been replaced by a computer-controlled zero-adjustment scheme. By sampling the

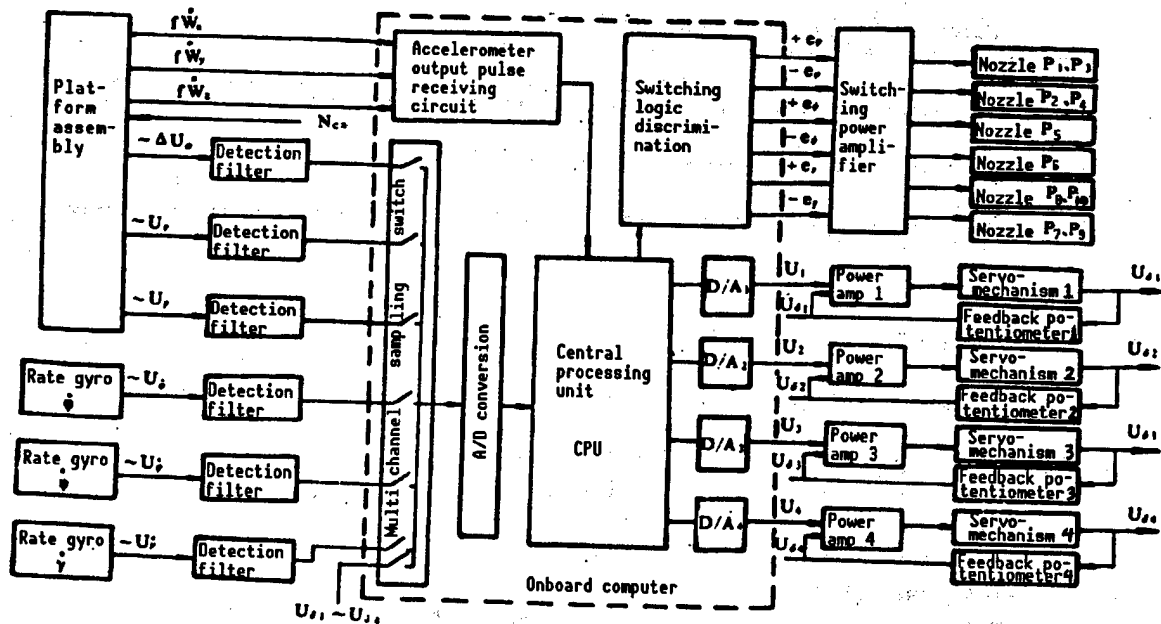

Figure 2. Block Diagram of the Digital Attitude Control System

output signals $U_{\delta 10}-U_{\delta 40}$, the computer generates a compensation signal based on a static closed-loop control theory; the signal passes through the power amplifier and activates the first-stage servomechanism to perform zero-adjustment. The zero-adjustment with the new scheme is accomplished without additional hardware, and the accuracy of adjustment has been improved from 0.2° to 0.1° .

3. Circuits and Instruments of the Control System

In the circuit design of the control system, the guidance command and the attitude control system share the same onboard computer. The computer is equipped with a D/A conversion circuit, and the system operates in a hybrid digital/analog mode. Effective measures have been implemented in the design to improve the system's interference-rejection capability. For example, the computer housing is isolated from the body of the launch vehicle and is connected to the zero-line of the power supply. At the input/output port of the computer where long cables are required, decoupling capacitors are used to eliminate spike pulse interference. Also, transformers, photoelectric couplers, and line isolators are used between the signal input and output interfaces, and the transmission cables are generally grounded or connected to the zero-line of the power supply.

The secondary power supply of the control system has a miniaturized design with improved supply system. The new design has some distinct advantages over previous models (see Table 1).

Table 1. Advantages of the Miniaturized Secondary Power Supply

	Product variety	Number of units	Total weight (kg)
LM-4	5	6	25
Original model	8	12	64

(1) Onboard computer

The technical specifications of the onboard computer are as follows:

Oscillator frequency	4000 kHz
Word length	16 bits
Operating speed	addition/subtraction 3.5 μ s multiplication 13 μ s, division 13.75 μ s
Main storage capacity	4 kB (use semiconductor storage devices)
Operating mode	single-word fixed-point and double-word fixed point
Instructions	55 basic instructions 30 channel instructions
Interrupt stages	8 stages of program-assigned priorities
Number of bits in A/D converter	11 bits
A/D conversion speed	less than 2 ms
Sampling period	20 ms
Number of sampling switch channels	22 channels

(2) Bi-directional swiveling [i.e., gimbale] servomechanism

The bi-directional swiveling servomechanism has a dual-actuator design where two servo-actuators are operated by a single hydraulic-fluid supply unit. Its technical parameters are listed in Table 2.

Table 2. Performance Parameters of Bi-Directional Swiveling Servomechanism

Parameter name	Parameter value
Load moment	Moment of inertia: 22.5 N-m-s ² Rated load: 766.88 N-m
Output turn angle	$\pm 4^\circ$
Output angular velocity	No load: $\geq 38^\circ/\text{s}$ With load: $\geq 20^\circ/\text{s}$
Time of continuous operation	15 min
Design life	50 hrs
Weight	20.5 kg

4. Test and Launch Control Equipment

The ground test and launch-control equipment is designed to perform the functions of testing, overall inspection, pre-launch inspection, and launch control of the various subsystems of the launch vehicle. The test and launch-control equipment of the LM-4 is a multi-chassis CAMAC system which has a star-shaped distributed microprocessor network; it has four chassis, one parallel port, and two serial ports. Its block diagram is shown in Figure 3.

In Figure 3, the main computer controls the operation of the CAMAC main chassis via the parallel port; information exchange with the Z-80 microprocessor in the distributor CAMAC chassis is accomplished via one of the serial ports, and information exchange with the Z-80 microprocessor in the sampling CAMAC chassis is accomplished via the other serial port. The Z-80 microprocessor also controls the operation of the two CAMAC chassis.

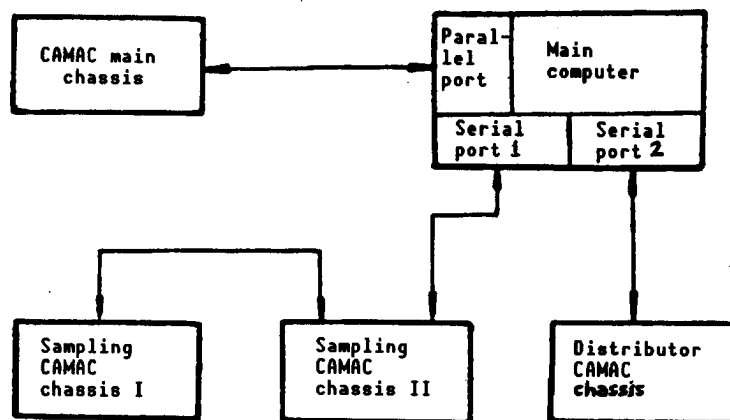

Figure 3. Block Diagram of the Test and Launch-Control Equipment

Communications with the onboard computer is accomplished through the modules of the CAMAC main chassis; measurement of certain parameters such as voltage, current, time, frequency, and period is accomplished through the corresponding modules in the two sampling CAMAC chassis; and measurement of the distribution, control status, and time-sequence signal of the onboard instruments is accomplished through the modules in the distributor CAMAC chassis.

The ground test and launch-control equipment also includes a DFS-1 simulation real-time processing system which can autonomously perform the testing and real-time processing of data measured by the onboard computer.

5. Test and Launch Software

The test and launch software is developed from the basic software of the CAMAC test and launch-control equipment. It includes four major program modules; the guidance system test module, the attitude control system test module, the overall launch inspection module, and the unit inspection module. There are a total of 19 programs.

In addition, a set of system service programs have been developed for the test and launch software; they consist of 15 subroutines which provide the following services: power supply and power distribution, vehicle-to-ground communications, loading of flight programs, and printing service. All the subroutines can be shared by the test and launch software; each subroutine is designed to be general, modular, and to perform a specific function.

4. Test and Launch Control Equipment

The ground test and launch-control equipment is designed to perform the functions of testing, overall inspection, pre-launch inspection, and launch control of the various subsystems of the launch vehicle. The test and launch-control equipment of the LM-4 is a multi-chassis CAMAC system which has a star-shaped distributed microprocessor network; it has four chassis, one parallel port, and two serial ports. Its block diagram is shown in Figure 3.

In Figure 3, the main computer controls the operation of the CAMAC main chassis via the parallel port; information exchange with the Z-80 microprocessor in the distributor CAMAC chassis is accomplished via one of the serial ports, and information exchange with the Z-80 microprocessor in the sampling CAMAC chassis is accomplished via the other serial port. The Z-80 microprocessor also controls the operation of the two CAMAC

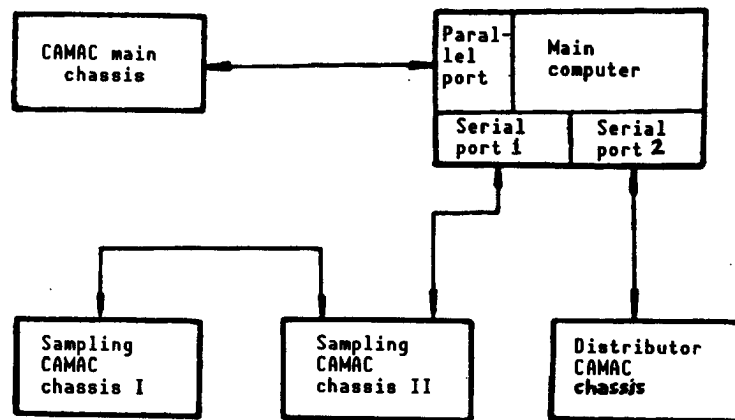

Figure 3. Block Diagram of the Test and Launch-Control Equipment

chassis. Communications with the onboard computer is accomplished through the modules of the CAMAC main chassis; measurement of certain parameters such as voltage, current, time, frequency, and period is accomplished through the corresponding modules in the two sampling CAMAC chassis; and measurement of the distribution, control status, and time-sequence signal of the onboard instruments is accomplished through the modules in the distributor CAMAC chassis.

The ground test and launch-control equipment also includes a DFS-1 simulation real-time processing system which can autonomously perform the testing and real-time processing of data measured by the onboard computer.

5. Test and Launch Software

The test and launch software is developed from the basic software of the CAMAC test and launch-control equipment. It includes four major program modules; the guidance system test module, the attitude control system test module, the overall launch inspection module, and the unit inspection module. There are a total of 19 programs.

In addition, a set of system service programs have been developed for the test and launch software; they consist of 15 subroutines which provide the following services: power supply and power distribution, vehicle-to-ground communications, loading of flight programs, and printing service. All the subroutines can be shared by the test and launch software; each subroutine is designed to be general, modular, and to perform a specific function.

Carrying out a particular function in the test and launch software requires calling only one subroutine.

The unique features of the test and launch software are:

(1) Vehicle-to-ground communications is accomplished in the responder mode. When the ground computer (onboard computer) receives a code from the onboard computer (ground computer), it sends a response code back to the onboard computer (ground computer), which upon response reception, can continue to transmit to the ground computer (onboard computer). Protective measures are implemented in the data transmission process from the ground computer to the onboard computer; also, circular queues are used to enhance the fault-diagnosis capability in communications.

(2) Every test performed on the attitude control system requires the input of large amounts of data on the sampled codes including the print-symbol code, control-word code, and display code. In order to facilitate the reading, editing, and use of the data files, they are stored and retrieved on a random-access basis. In other words, each test constitutes a record in the file, and each record contains a series of interrelated codes. To carry out a particular test, it is only necessary to retrieve the corresponding codes according to the specified record number.

(3) In the design of the test and launch software, modularized tree structures and menu-type operations are used extensively. Based on the overall functional requirements of the software, a tree structure is designed to connect the individual functional modules. In the process of program execution, a menu-type operational mode is used to schedule the execution of these modules; in particular, they may be executed sequentially or in the order of an altered sequence; or only a selected number of modules are executed. Once a fault is detected, the fault processing module is entered, and after corrective measures are taken, program execution continues. The entire program is highly flexible and has effective fault-correction capability.

III. Flight Test Results

Two successful flight tests of the LM-4 launch vehicle have been conducted. The measured orbit parameters obtained from the second flight test compare favorably against accuracy specifications, as shown in Table 3. The measured accuracies of the attitude angles at the time of satellite-rocket separation are shown in Table 4.

Table 3. Satellite Orbit Parameters

Parameter	Theoretical value	Measured value	Deviation	Specification
Semi-major axis (km)	7274.096	7274.165	1.069	≤ 40
Eccentricity	0.95×10^{-4}	0.35×10^{-3}	0.25×10^{-3}	≤ 0.005
Inclination (deg)	98.9	98.958	0.058	≤ 0.12

Table 4. Attitude Angles at Time of Satellite-Rocket Separation

Name	Symbol	Value	Specification
Attitude angle	$\Delta\phi$	0.127°	$\leq 1^\circ$
	ψ	-0.191°	$\leq 1^\circ$
	γ	0.16°	$\leq 0.5^\circ$

New 10-GW Tunable Narrow-Linewidth Nd:Glass Laser Described

92FE0168A Beijing ZHONGGUO KEXUE, Series A in Chinese No 8, Aug 91 pp 883-889

[Article by Wu Hongxing [0702 7703 5281], Guo Dahao [6753 1129 3185], Wang Shengbo [3769 5116 3134], and Dai Yusheng [2071 1342 3932] of the Department of Physics of China University of Science and Technology, Hefei 230026: "New 10-GW Tunable Narrow-Linewidth Nd:Glass Laser"; MS received 4 Dec 90]

[Text] Abstract

The special features of a new 10-GW tunable narrow-linewidth Nd:glass laser, several physical problems associated with the laser, the overall optical layout and key technologies, and the overall output characteristics are described.

I. Introduction

A 10-GW-class high-power Nd:glass laser has extremely important applications in the study of laser-induced nuclear fusion, multi-photon ionization of atoms and molecules and X-ray lasers, laser plasma X-ray (LPX) microscopy, plasma physics, plasma spectroscopy, and material properties at ultrahigh temperatures and ultrahigh pressures. In many applications, such as in the study of atomic resonance multi-photon ionization and effective pumping mechanism to generate X-ray lasers, not only must the laser have a high power output but also the output wavelength must be continuously tunable over a certain range. However, because most laser facilities developed by various laboratories are mainly focused on laser fusion research^[1-4], there is no pressing need to make the laser wavelength tunable. Furthermore, it is technically difficult to make the wavelength of a high-power Nd:glass laser tunable. Prior to this work, all high-power Nd:glass lasers built in China were not tunable.

Based on the fact that Nd:glass has a wide fluorescence band, key breakthroughs were made in five areas: Nd:glass tunable narrow-linewidth Q-switched oscillator, pre-Q-switched selection of single transverse mode, F-P [Fabry-Perot] etalon-pre-Q-switched selection of single longitudinal mode (SLM), multi-stage amplifier and stability of overall laser power output in tuning.

For the first time in the world, the output laser wavelength of a 10-GW Nd:glass laser is continuously tunable within its gain bandwidth. A new 10-GW tunable narrow-linewidth Nd:glass laser, the first in the world, has been developed.

II. Physical Problems Associated With Wide-Tuning Narrow-Linewidth Q-Switched Nd:Glass Laser and Its Amplification Process

1. Tunable Range of Laser Wavelength

The laser is made tunable based on the fact that Nd:glass itself has a wide fluorescence band. In order to determine the tunable range of the laser, we must know the spectrum of Nd:glass. The broadening of Nd:glass is nonuniform and is primarily due to inhomogeneous doping. The spectral profile can only be determined experimentally.

Figure 1 shows the measured broadening profile (gain profile) for the type III silicate Nd:glass used in the apparatus.

From Figure 1, if tunability can be achieved within the FWHM (full width half maximum) of the Nd:glass profile, then the tunable range is $\Delta\lambda = 280$ [Å]; the center wavelength $\lambda_0 = 10594$ [Å].

2. Gain From Amplification of Tunable Narrow-Linewidth Nd:Glass Laser

When the wavelength of a tunable Q-switched Nd:glass laser oscillator varies continuously within the gain bandwidth, the gain of the amplification system also varies accordingly (at a constant pumping power density). In particular, the large-signal gain factor varies differently at different stages and in different parts of the same stage of amplifier. Hence, the dependence of the gain of the entire amplifier system upon wavelength is extremely complicated. This makes it very difficult to accurately control power and energy when tuning the laser wavelength.

(i) Small-Signal Gain During Tuning of Laser Wavelength

Because the small-signal gain is only a function of wavelength, and is independent of intensity, the relation between the small-signal gain and laser wavelength can be derived directly from the gain curve of Nd:glass:

$$\alpha_0(\lambda) = \sigma(\lambda) \cdot g(\lambda) \cdot \Delta N(\lambda), \quad (1)$$

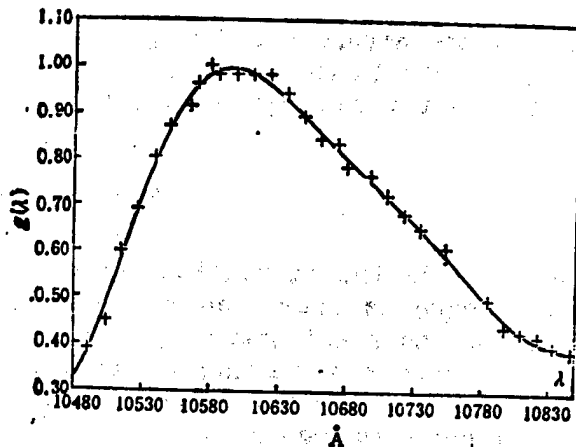

Figure 1. Gain Profile for Silicate Nd:Glass

where $\sigma(\lambda)$ is the lasing cross section, $\Delta N(\lambda)$ is the population inversion density, and $g(\lambda)$ is a curve function. Under small-signal conditions, the gain curve $\alpha_0(\lambda)$ and spectrum broadening profile $g(\lambda)$ are approximately the same. Since the spectrum broadening profile $g(\lambda)$ for Nd:glass must be experimentally determined, the small-signal gain of the entire system as a function of laser wavelength can be obtained by measuring the spectrum broadening profile $g(\lambda)$ or the small-signal gain profile $\alpha_0(\lambda)$.

(ii) Large-Signal Gain During Tuning of Wavelength

For a nonuniform broadening medium, the gain saturation at different wavelengths within the gain band, i.e., the variation of large-signal gain factor with light intensity, is identical. Thus:

$$\alpha(\lambda, I) = \alpha_0(\lambda) / \left(1 + \frac{I_\lambda}{I_s}\right)^{\frac{1}{2}}, \quad (2)$$

where I_s is the saturation intensity. When $I_\lambda = I_s$, the gain factor at every wavelength is decreased to $1/\sqrt{2}$ of its small-signal gain factor. However, because the small-signal gain factor is a function of wavelength and because in a nonuniform working medium when a narrow-linewidth laser passes through the amplifying medium only population inversion in the corresponding width of wavelength is contributing to the gain, large-signal amplification will produce a frequency hole-burning effect. Hence, the large-signal gain factor varies differently as a function of wavelength.

Consider the fact that the extremely fast energy transfer process between high-energy-level particles in Nd:glass, i.e., the cross-relaxation process, is of the order of 10^{-10} s and the pulse width of the laser is of the order of 10^{-9} s. Under such condition, the number of population-inverted particles consumed corresponding to the wavelength of interest will be fully replenished by particles corresponding to other wavelengths. There is no frequency hole-burning effect. The result is that the amplitude of the entire gain curve falls, similar to the situation of gain saturation in a uniform broadening medium.

Based on the above discussion, under specific conditions of the apparatus, the frequency hole-burning effect will not occur using the nonuniform Nd:glass medium. Therefore, at the same intensity, the proportion of gain decrease at different wavelengths is the same due to gain saturation. Thus, the variation of large-signal gain with wavelength during tuning is identical to that of small-signal gain.

(iii) Automatic Broadening of Narrow-Linewidth Q-Switched Laser in Traveling-Wave Amplification

When a narrow-linewidth Q-switched laser pulse passes through an amplifying medium, because the index of refraction n is dependent upon the light intensity (the nonlinear part), time modulation of the phase of the optical radiation field (self-phase modulation) occurs. Consequently, it causes the automatic broadening of the narrow-linewidth laser pulse.

Since the light intensity is not constant over the duration of the laser pulse, the variation of index of refraction n as a function of time when the laser pulse passes the Nd:glass medium is:

$$n(t) = n_0 + \Delta n = n_0 + n_2 E^2, \quad (3)$$

where n_0 is the normal index of refraction which is independent on light intensity; n_2 is the coefficient expressing the dependence of index of refraction upon intensity, and is called the coefficient of nonlinear index of refraction; and E is the electric field of the laser light.

The optical electric-field phase change caused by the variation of the index of refraction as a function of time when the laser pulse passes the Nd:glass medium is

$$\Delta\phi = k \int_0^L \Delta n \cdot dz, \quad (4)$$

where L is the total length of Nd:glass and k is the wave number. Hence, this causes the laser field frequency to vary as follows^[5]:

$$\omega(t) = \omega_0 + \Delta\omega, \quad (5)$$

$$\Delta\omega = \frac{\partial\Delta\phi}{\partial t} = \frac{1.3}{\Delta t} k L n_2 E_{\max}^2, \quad (6)$$

where Δt is the duration of the laser pulse (pulse width).

The corresponding self-broadening of the laser spectral line is

$$\Delta\lambda = \frac{1.3}{\Delta t} \cdot \frac{\lambda}{c} \cdot L \cdot n_2 \cdot E_{\max}^2. \quad (7)$$

As far as the type III silicate Nd:glass used is concerned, $n_2 = 1.6 \times 10^{-13}$ e.s.u. = $1.6 \times 10^{-22} \text{m}^2/\text{v}^2$. The center wavelength $\lambda_0 = 1.0594 \mu\text{m}$, total length of the Nd:glass rod $L = 5 \text{ m}$, laser pulse $\Delta t = 4 \times 10^{-9} \text{ s}$. The laser power density $I \leq 1 \text{ GW/cm}^2$ and the corresponding light electric field is $E_{\max} = 0.738 \times 10^8 \text{ V/m}$. Substituting the above numbers into equation (7), one obtains

$$\Delta\lambda = 0.05 \text{ \AA}$$

This means that after the resonant oscillator laser pulse passes the entire amplifier system, the linewidth of the laser is broadened by approximately 0.05 \AA due to self-phase modulation. This indicates that the linewidth of the laser output can be compressed to a limit of 10^{-2} \AA .

(iv) Requirements for Compressing the Linewidth of a Tunable Nd:Glass Laser Oscillator

Based on the above analysis, the self-broadening of laser linewidth is of the order of 10^{-2} \AA within the laser power density range attainable. In other words,

even if we have a single-frequency laser oscillator, the linewidth will be of the order of 10^{-2}\AA after amplification. From this angle, the linewidth of the tunable Nd:glass laser oscillator output only needs to be compressed to 10^{-2}\AA . Nevertheless, because the length of the resonance cavity cannot be shortened too much, there will be several longitudinal modes in the 10^{-2}\AA bandwidth. Therefore, serious waveform modulation due to mode self-locking (or beating)^[10], leading to instability of the power output, is unavoidable. To this end, in order to stabilize laser output, one must eliminate self-locking. The most effective way to eliminate self-locking is to make the tunable laser oscillator operate in an SLM. Based on this consideration, the linewidth of the laser oscillator should be compressed to the SLM state.

III. Layout of the Overall Optical System and Its Technical Characteristics

The entire laser consists of the following subsystems: tunable narrow-linewidth Nd:glass Q-switched laser oscillator, Nd:glass laser preamplifier (two-stage), optoelectronic wave-shaving switch, 20 diameter x 500 triple-path Nd:glass main amplifier, 20 diameter x 500 Nd:glass laser main amplifier (two-stage), 35 diameter x 500 Nd:glass laser main amplifier (three-stage), 45 diameter x 500 Nd:glass laser main amplifier (two-stage), optoelectronic isolator, optomagnetic isolator (two-stage), and spatial frequency filter.

The layout of the optics of the entire system is shown in Figure 2.

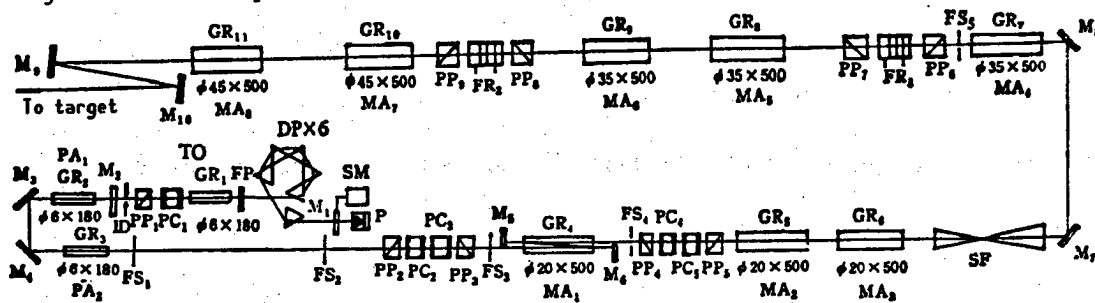

Figure 2. Layout of the Optics of the System
 (GR: Nd:glass rod; DP: dispersion prism; PP: polarizing plate;
 PC: Puckle case; FR: Faraday isolator; SF: spatial frequency filter;
 M: reflecting mirror; FP: Fabry-Perot etalon; FS: fixed stop;
 ID: variable diaphragm; P: PIN photodiode; TO: tunable oscillator;
 PA: pre-amplifier; MA: main amplifier; SM: stepper motor)

The following five technologies were implemented for the first time:

1. A set of dispersion prisms machined from six pieces of specially purified ZF_6 blocks was used to achieve a wide tunable range of no less than 280\AA using an oscillator with a 6-mm-diameter, 200-mm-long Nd:glass. Furthermore, the fundamental-mode laser pulse output over the entire tunable range is approximately 20 mJ. This is the highest level attainable to date for a tunable Nd:glass laser oscillator.

2. A mode-selecting Q-switching technology was employed to choose a single transverse mode in order to realize a high-quality single-transverse-mode output.

3. A combination F-P etalon/pre-laser Q-switching technique was used to achieve SLM output from the tunable Nd:glass laser oscillator.

4. Triple-path amplification is formally used in the high-power Nd:glass laser. In a single-stage 20-mm-diameter, 500-mm-long Nd:glass amplifier, an amplification factor of approximately 200 was obtained. In addition, the required optical-path time delay was also obtained.

5. By using an overall gain compensation technique based on the gain profile measured experimentally, a steady laser energy (power) output from the 10 GW high-power Nd:glass laser during tuning was achieved.

IV. Overall Output Characteristics

The overall laser output characteristics are as follows:

1. The overall tunable range of the output laser wavelength (tunable range of the oscillator) is:

$$(\lambda_0 - 62 \text{ \AA}) \sim (\lambda_0 + 224 \text{ \AA}),$$
$$\Delta\lambda \geq 286 \text{ \AA}, \lambda_0 = 10594 \text{ \AA}.$$

Figure 3 shows a spectrum over the entire tunable range taken by a WP₁ planar grating spectrograph after frequency doubling.

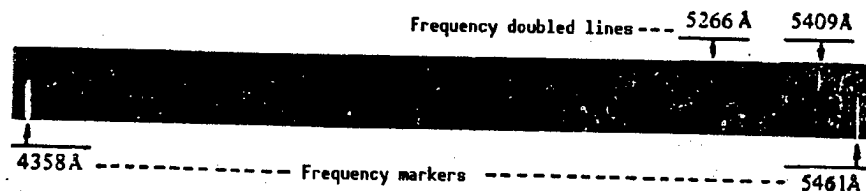

Figure 3. Spectrum of Frequency-Doubled Laser Output Over the Tunable Range

It was found that the tunable range of the laser output on the shorter-wavelength side deviates somewhat from the gain width of Nd:glass. The gain curve used in this work was measured by a threshold method. It corresponds to a small-signal gain situation. However, the laser normally operates in a large-signal gain situation and there is a serious gain saturation effect. Furthermore, the broadening of the Nd:glass spectrum is nonuniform. When lasing is established at a certain wavelength and the corresponding particle population inversion is significantly decreased, it can be replenished by other high-energy-state particles corresponding to other wavelengths through an energy-exchange process (i.e., cross-relaxation process). The higher the rate of cross relaxation, the greater the number of inverted particles available, and the higher the energy attainable. The fact that the tunable wavelength range on the shorter-wavelength side deviates from the gain linewidth of Nd:glass might be because the relaxation rate of shorter-wavelength inverted particles toward long wavelength is higher than that of longer-wavelength inverted particles toward shorter wavelength.

2. When the peak laser pulse power is no less than $10^{10}W$, the tunable wavelength range is:

$$(\lambda_0 - 58 \text{ \AA}) - (\lambda_0 + 104 \text{ \AA}),$$

$$\Delta\lambda \geq 162 \text{ \AA}, \lambda_0 = 10594 \text{ \AA}.$$

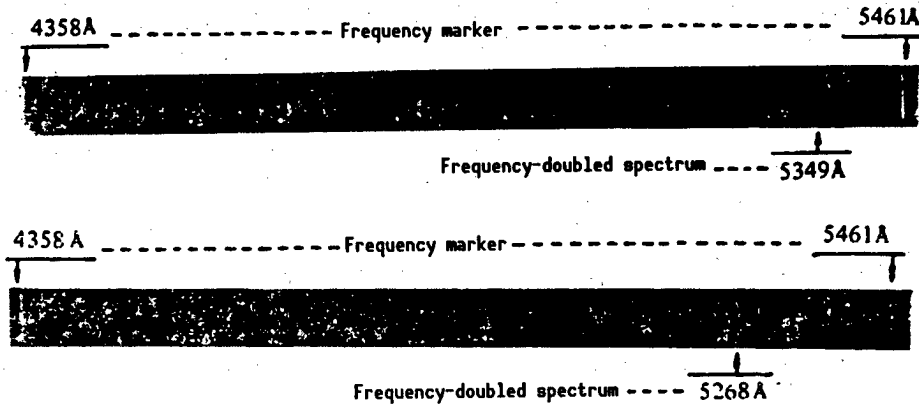

Figure 4. Frequency-Doubled Laser Spectrum Over Tunable Range With Power at Least $10^{10}W$

Figure 4 shows the spectrum of the frequency-doubled laser over the tunable range.

3. Full width at half maximum (FWHM) of the laser = $4 \times 10^{-9}s$.

Figure 5 [photo not reproduced] shows a photograph of the final-stage-amplifier output laser waveform displayed by a 7834 storage oscilloscope.

Using a 30 ps mode-locked laser for calibration, the intrinsic response time for the PIN detector-7834 oscilloscope system is $1 \times 10^{-9}s$. The scan rate of the oscilloscope is 5 ns/half division.

4. Laser Pulse Energy and Peak Power

A plane absorption radiometer was used to measure the energy and power of laser pulses corresponding to $\lambda = \lambda_0 + 104 \text{ \AA}$ and $\lambda = \lambda_0 - 58 \text{ \AA}$; the results are shown in Table 1.

5. Laser Linewidth

Figure 6 [photo not reproduced] shows a photograph of the output waveform of the tunable Nd:glass laser in SLM using a combination of F-P etalon and pre-laser Q-switching technique. The scan rate of the oscilloscope is 20 ns/half division in the picture. It was found to be a smooth curve and there is no sign of modulation. This fully demonstrates that the oscillator is operating with an SLM output^[6-8]. Thus, the output laser linewidth has reached the limiting width, which is determined by the self-broadening effect due to phase modulation.

Table 1

Wavelength (Å)	Optical pumping energy density at different stages W_p [J/cm ³]	Laser pulse energy E Pulse peak power P
$\lambda = \lambda_0 + 104 = 10698$	TO: 96.0 PA ₁ , PA ₂ : 120.0 MA ₁ x 3: 44.0 MA ₂ , MA ₃ : 48.2 MA ₄ , MA ₅ , MA ₆ : 31.5 MA ₇ , MA ₈ : 27.3	E = 58.7 J P = 1.47 x 10 ¹⁰ W
$\lambda = \lambda_0 - 58 = 10536$	TO: 97.6 PA ₁ , PA ₂ : 128.7 MA ₁ x 3: 48.2 MA ₂ , MA ₃ : 51.6 MA ₄ , MA ₅ , MA ₆ : 33.6 MA ₇ , MA ₈ : 29.0	E = 59.4 J P = 1.49 x 10 ¹⁰ W

Figure 7(a) and (b) [photos not reproduced] show the pulse waveforms with conventional Q-switching, i.e., without using the F-P etalon—pre-laser Q-switching technique. One can see different degrees of modulation due to self-mode-locking.

6. Laser Divergence (Energy focusability)

The divergence of the laser beam from the final-stage amplifier was measured to be less than 0.36 mrad (equivalent to 9.7 times the diffraction-limited angle) using an optical wedge method. Figure 8 [photo not reproduced] is a photograph showing focal spots of the laser output using the optical wedge. The divergence of the beam could be determined after measuring the diameter of each spot and carrying out the necessary calculation^[9].

7. Output Stability

Under identical operating conditions, the laser was fired 12 times. The fluctuation in laser pulse energy and peak power is less than 10 percent.

The authors wish to thank Shanghai Institute of Optics and Fine Mechanics of the Chinese Academy of Sciences and dozens of people such as Fan Dianyuan [5400 3329 0337] for their support and assistance in the development of the apparatus.

References

1. Charatis, G., et al., "Plasma Physics and Controlled Nuclear Fusion Research," 5th Conference Proceedings, Tokyo, Nov 1974, p 317.
2. Basov, N.G., et al., RĒZĀ KENKYU [LASER RESEARCH], Vol 4, 1976, p 187.
3. Ahlstrom, H.G., et al., Ibid., Vol 4, 1977, p 1.
4. Deng Ximing, et al., GUANGXUE XUEBAO [ACTA OPTICA SINICA], Vol 1, 1981, p 289.
5. Shimizu, F., PHYS. REV. LETT., Vol 19, 1967, p 1097.
6. Kuizenga, D.J., IEEE J. OF QUANTUM ELECTRONICS, Vol QE-17, 1981, p 1702.
7. Hanna, D.C., et al., OPTO-ELECTRON., Vol 4, 1972, pp 249-256.
8. Park, Y.K., et al., OPT. LETT., Vol 5 No 5, 1980, pp 96-98.
9. Editing group of laser parameter measurement, "Measurement of Laser Parameters," Shanghai People's Publishing House, Shanghai, 1976, p 23.
10. Guo Dahao, Wu Hongxing, et al., GUANGXUE XUEBAO [ACTA OPTICA SINICA], to be published.

Domestic Multi-Function TVRO/VSAT Small Earth Stations Described

92FE0153A Shanghai DIANXIN KUAIBAO [TELECOMMUNICATIONS INFORMATION] in Chinese No 10, Oct 91 pp 2-5

[Article by Chen Zhaoji [7115 5128 1015]: "China's Multi-Function Small Earth Stations"]

[Text] Abstract

This article introduces the concept of linking China's existing television receive-only (TVRO) earth stations with the rapidly growing very-small-aperture satellite terminal (VSAT) network around the world to provide multi-function capability for domestic earth stations. This concept is designed to facilitate the development of China's satellite communications and broadcast industry, particularly the construction and development of small earth stations in China's remote regions. Several candidate designs and configurations of the VSAT network are proposed. In addition, the problems associated with developing these multi-function earth stations are also discussed.

1. Proposed Concept

Since INTELSAT was first used for transoceanic communications in 1964, satellite communication technology has been used extensively in a wide range of different applications. The current development trend in communications satellites is toward higher and more complex signal processing capabilities, increased satellite weight, power and volume, and improved reliability. The development trend of earth stations on the other hand, is toward smaller size and lower cost.

As digital technology becomes more mature and finds wider applications in ground facilities, advanced digital transmission technology has also been used on satellites in recent years to achieve higher communications performance and efficiency. VSAT is a new technology developed in the mid 1980s; it is primarily used for low-data-rate transmission and voice transmission between small earth stations. Because of its many desirable features such as robustness, multiple access capability, simple configuration, low cost, ability to share expensive main earth stations and satellite channels, ease of implementation and maintenance, it has grown rapidly around the world; in recent years, its application has also expanded in this country.

Many Chinese organizations in the news media, the banking industry, the energy exploration industry, the transportation industry, the earthquake research institutions as well as the China Broadcast Satellite Co., have established C-band VSAT networks. As satellite communications continues to grow in this country, this technology will undoubtedly be used by an increasing number of other organizations, and VSAT systems in the Ku band will be developed.

In addition to developing VSAT communications systems, China has also been actively engaged in the development of direct-broadcast satellite (DBS) TV. Currently, there are more than 20,000 independently developed TVRO stations in this country. If TVRO technology can be combined with VSAT technology to allow conversion of the existing TVRO stations into multi-function small earth stations, then it is possible to save the high cost of design, site selection, and construction of new VSAT stations. Furthermore, additional cost savings can be achieved by designing the multi-function earth stations so that the VSAT and TVRO segments can share the same antennas and other equipment. This approach will promote the use of advanced VSAT communication technologies and speed up the construction of VSAT stations and VSAT networks.

2. Candidate Designs of Multi-Function Small Earth Stations

2.1 Multi-Function Small Earth Station With Shared Antenna Feed Using a Microwave Power Divider

In this design, the microwave power distributor is located between the antenna feed and the TVRO system and VSAT system, as shown in Figure 1. This design is inexpensive and easy to maintain; however, the power loss from the microwave divider is quite high, and consequently the system G/T is rather low. Therefore, this design should only be used in a TVRO-converted multi-function station whose antenna aperture is larger than 6 m.

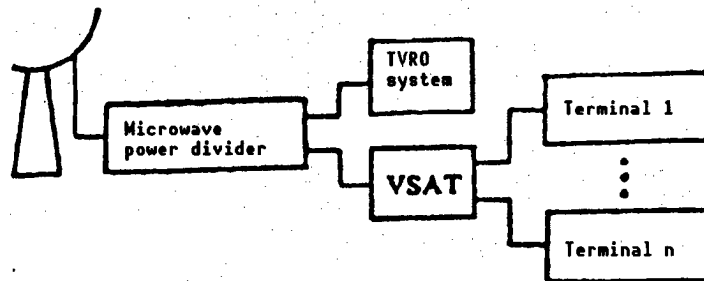

Figure 1. Multi-Function Small Earth Station With Shared Antenna Feed Using a Microwave Power Divider

2.2 Multi-Function Small Earth Station With Shared Antenna, Feed, and Low-Noise Amplifier (LNA)

In this design, the receiving microwave power divider is located after the LNA to avoid deterioration of the signal quality (Figure 2); it also provides additional channels to the VSAT and opens up voice services, thereby alleviating the current problem of overloaded telephone lines. This design deserves priority consideration.

2.3 Comprehensive Channel Utilization

During the periods when TV programs are off the air, it is possible to use the TV video channels to broadcast various types of business information; it is also possible to use the TV carrier to conduct INTELNET business during off hours.

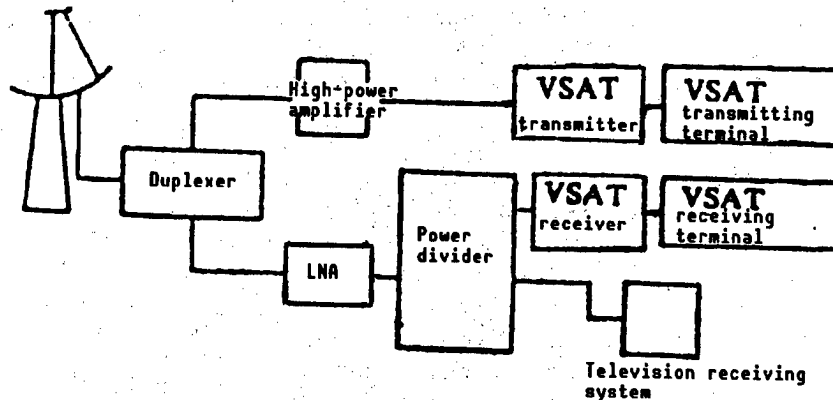

Figure 2. Multi-Function Small Earth Station With Shared Antenna Feed and LNA

Currently, China's TV reception is based on the PAL-D/K system. The resolution of this system is quite poor because it uses frequency-division multiplexing (FDM) subcarrier modulation. In order to improve the TV resolution and transmission quality, the state has decided to use the D₂-MAC (analog component time-division multiplexing (TDM)) system for future satellite TV transmission. With this approach it is possible to transmit multiple channels of digital audio and data information during periods of row blanking and field blanking.

3. Candidate VSAT Network Configurations for Integrated Multi-Function Earth Stations

There are three possible configurations for the VSAT network:

(1) Direct VSAT/VSAT Network

The main advantages of this configuration are that it has small terminals and does not require a large, central earth station. The disadvantages are that the satellite power consumption is high, voice channels are absent and the data rate is low. Therefore, this is not a viable configuration for integrated multi-function earth stations.

(2) Onboard Processing Network

The advantages of this configuration are that it allows direct VSAT/VSAT operation and makes efficient use of satellite power and bandwidth, and its onboard transponders can provide alternate modes of communication with both C-band and Ku-band earth stations. However, because of the sophisticated technologies involved, its current use is very limited.

(3) Central Station/User Network

The advantages of this configuration are that it has small terminals and provides both voice and data services; also, satellite power consumption is very low (only 1-2 W). The disadvantage is that it requires a central earth

station with a large-aperture antenna (8-20 feet) and centralized processing equipment. VSAT-to-VSAT transmission must pass through the central earth station's doublet-bounce relay, which has an associated 0.5-second time delay.

A careful review of the three options favors the third configuration, because the central earth station can simplify the design of the VSAT station, and provides high-speed (64 kb/s) voice and data communications. The large-aperture antenna used by the central earth station can reduce the transmitter power of the VSAT station and the power of the onboard transponder. In addition, if the link from the central earth station to the VSAT station (designated as the external link) operates in the TDM mode and the link from the VSAT station to the central earth station (designated as the internal link) operates in the frequency-division multiple access (FDMA) mode, then the VSAT equipment can be further simplified because FDMA does not require timing and TDM can obtain its timing information from the transmitted data. The single-carrier TDM mode used in the external link requires only a modulator, an up-converter and a power amplifier; therefore, the central earth station will not suffer inter-modulation effects associated with multiple carrier systems. Accordingly, the amount of equipment at the central station can be reduced and its design can be simplified.

4. Other Issues That Must Be Addressed

4.1 Selection of Multiple Access Mode

The VSAT network can use any of the conventional multiple access modes: time-division multiple access (TDMA), FDMA, single-channel per carrier (SCPC), and code division multiple access (CDMA); it can also use the newly proposed random multiple access (RMA) mode with improved effectiveness and efficiency.

4.2 Determination of Transmission Speed

Currently, many of the domestic TVRO stations use parabolic antennas with 6-m apertures; such an aperture is much larger than the required antenna size for VSAT earth stations. Therefore, a higher transmission speed can be used to provide more than one or two channels of telephone communications.

4.3 Selection of Distribution Mode

To satisfy the bandwidth requirement of a system that may contain several thousand integrated small earth stations around the country, it is not practical to use the pre-assignment mode; the only feasible approach is the demand-assignment mode.

For a small earth station with a single-channel terminal, one can use a common terminal shared by the signaling channel and the voice channel.

4.4 Control Mode

A centralized control system is used to simplify the configuration of the VSAT station.

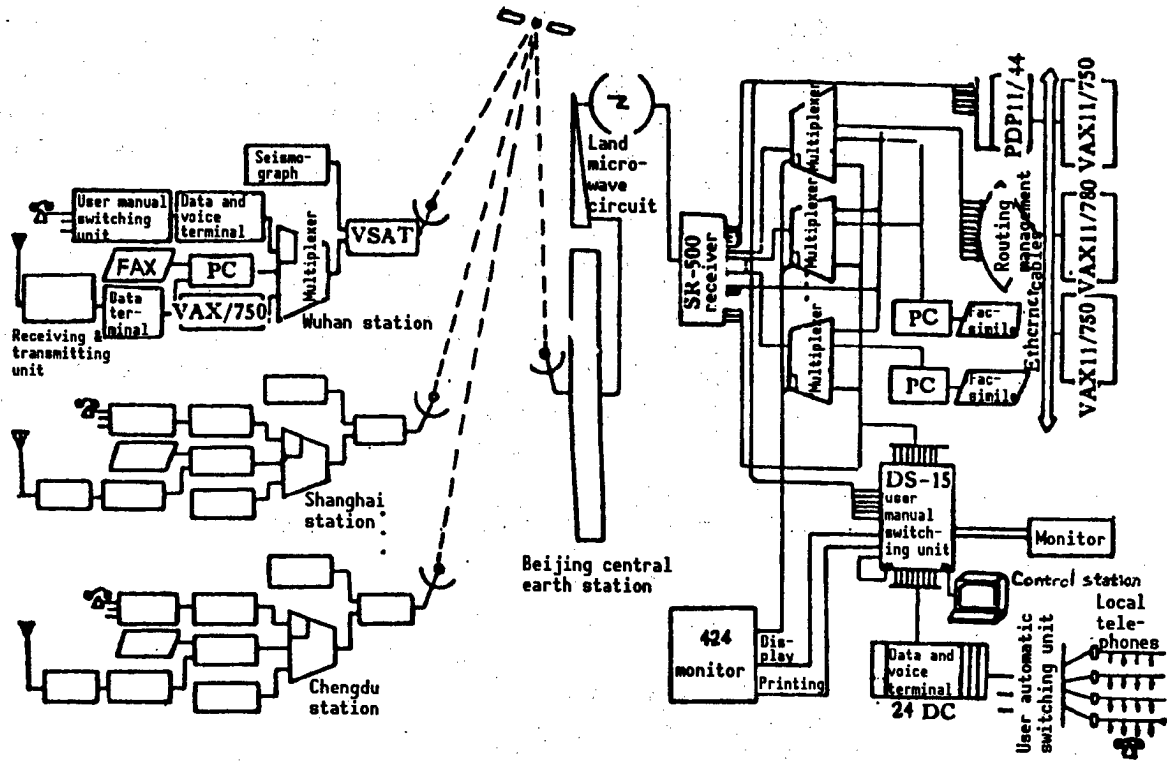

Figure 3. Structure of a VSAT Network

4.5 Network Interfaces

The network interfaces include interfaces with other satellite communications systems and with the ground network. The design of interfaces with other satellite communications systems must take into account differences in the selected multiple access mode and the data transmission speed. The ground interface is easy to implement because the types of terminals used in low-capacity multi-function earth stations are quite limited.

Regardless of the type of interface, the main consideration is to ensure continuity of the signaling channel and the voice channel; this is an important criterion for signaling standardization in the communications system of multi-function earth stations.

In addition, the following issues must also be considered: error coding and decoding techniques, modulation and demodulation techniques, bandwidth compression techniques for the signal sources, effective utilization of satellite power and frequency band, and construction of a central earth station/user in using existing VSAT central stations.

If the state takes on the responsibility to establish an overall plan, to provide the necessary funds, and to task the Ministry of Posts and Telecommunications to convert the existing TVRO stations into multi-function small earth stations, then it will be able to achieve the goal of developing China's satellite broadcasting and communications industry expeditiously.

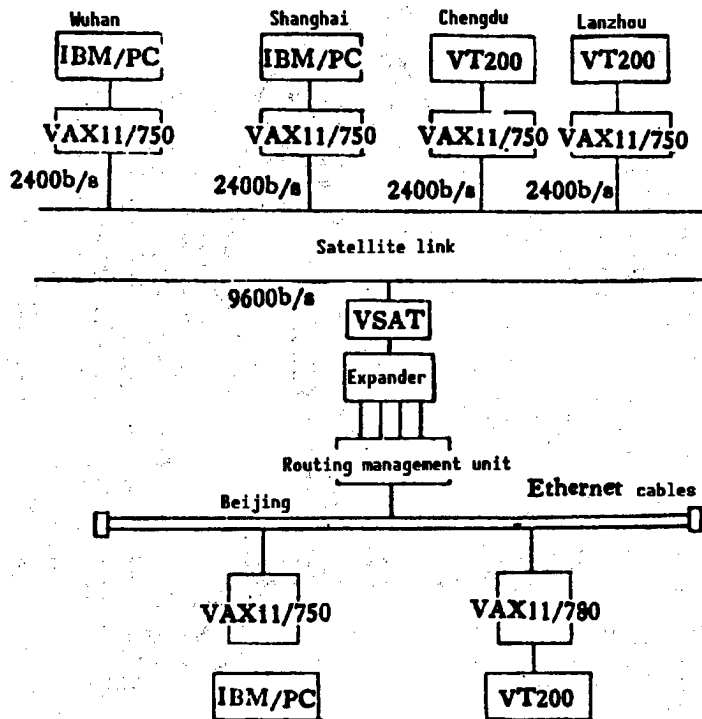

Figure 4. Block Diagram of the Satellite-Link Computer Network

Common Signaling TDMA Information Processing System Used for SCPC-DAMA Satcom System

92FE0153B Shanghai DIANXIN KUAIBAO [TELECOMMUNICATIONS INFORMATION] in Chinese No 10, Oct 91 pp 11-16

[Article by Tang Jihua [0781 4480 5478]: "Common Signaling Channel TDMA Information Processing System for SCPC-DAMA"]

[Text] Abstract

The issue of multiple access in a satellite communications system has always been of great interest to the communications engineer. By using demand assignment multiple access (DAMA), it is possible to increase network capacity and improve network efficiency and flexibility. In this article, the structure and procedure of the common signaling channel (CSC) time-division multiple access (TDMA) information processing system of the SCPC [single channel per carrier]-DAMA satcom system are described, and the parallel processing technique used in the system's distributed processors is introduced.

I. Introduction

DAMA can be used to improve the channel utilization of a satellite communications network. The SPADE [SCPC/PCM DAMA Equipment] system^[1] designed by COMSAT for INTELSAT-IV and INTELSAT-V was the first DAMA system used in satellite communications; tests and operational experience of the SPADE system show that the DAMA design can^[4-6]:

- A. provide effective service to light traffic links;
- B. handle overflow traffic from pre-assignment circuits;
- C. facilitate network design by establishing communications links between the earth stations on an as-needed basis;
- D. optimize the use of satellite capacity and equipment at existing earth stations.

The maritime satellite communications system of the INMARISAT organization is another example of successful application of DAMA^[2]. Today, DAMA has been used by many countries for their domestic satellite communications network^[3,7-10]. It is predicted that the transition from pre-assignment networks (particularly networks with sparse routing systems) to DAMA networks will become a trend of the future. This article gives a detailed description of the hardware components and software structure of the common signaling channel TDMA information processing system (CSC-TDMA-IPS) developed by the No. 1 Research Institute of the Ministry of Posts and Telecommunications (MPT). The effective use of advanced software and hardware technologies and the high performance-to-price ratio of this system make it a practical design for engineering applications.

2. System Description

The demand assignment control system described in this paper is used in a mesh network to provide fully variable decentralized channel control. The SCPC-DAMA system block diagram is shown in Figure 1.

The CSC-TDMA IPS is located between the main computer and the CSC synchronizer; the common signaling channel uses the TDMA mode. The main functions

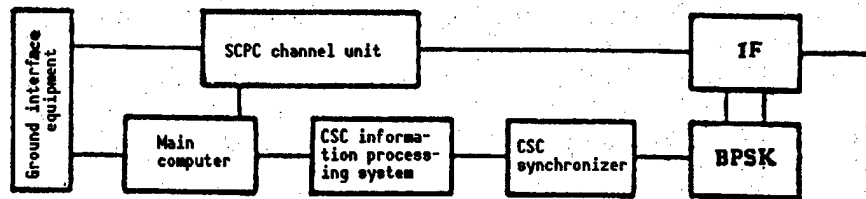

Figure 1. SCPC-DAMA System Block Diagram

of this system are to convert the ground-segment standard signals into CSC-TDMA instruction format for transmission, and to receive and identify space-segment signals transmitted from other ground stations and convert them into ground-segment standard signals. Thus, it accomplishes the task of establishing ground-to-ground communications by using the satellite transponder as a relay.

The system must be able to process in real time information from all the stations within the network and information originated from the local station as well as the broadcast information transmitted by all other stations. Because of the real-time requirement and the long processing time, the system uses low-cost 8749 single-chip computers to perform the tasks of information processing and information exchange with the main computer via the bus. A block diagram of the CSC-TDMA IPS is shown in Figure 2.

3. Performance of System Circuit

Communications between this system and the common channel synchronizer is accomplished by the serial-parallel conversion circuit (from the synchronizer to the 8749 chip), the parallel-serial conversion circuit (from the 8749 chip to the synchronizer) and the corresponding synchronizer control signals. The data from the 8749 chip to the common channel synchronizer are transmitted under interrupt control; the data from the synchronizer are received by the 8749 chip under polling control. In order to ensure

synchronization between the 8749 chip and the synchronizer, it is necessary to carefully examine the issue of program execution time in the software design. Calculations and test results show that in the case of a milli-second-level sub-frame, it is quite feasible to use the interrupt/polling design.

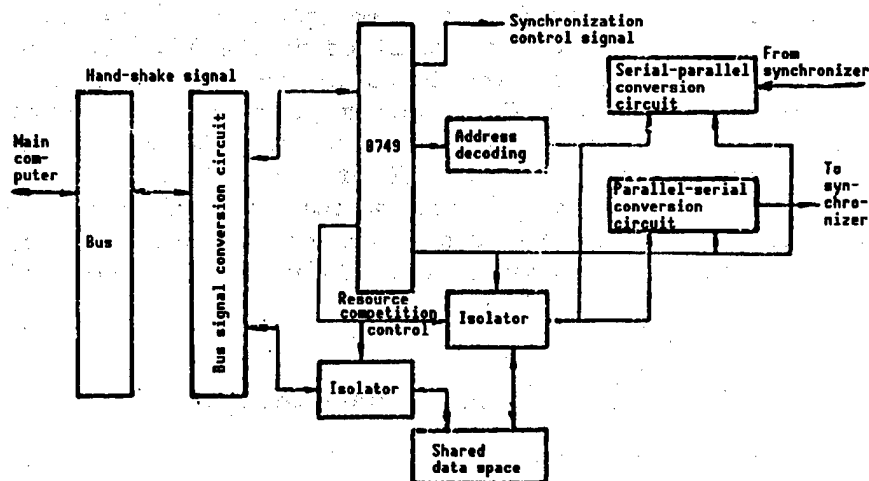

Figure 2. Block Diagram of CSC-TDMA IPS

[Note: Since the 8749 chip only has a single-stage interrupt which is already used for transmission, one can only use the polling mode; if a multi-stage interrupt design is to be implemented, then additional circuits are required. The current design is chosen based on considerations of the complexity of hardware and software, and trade-off between performance and cost.]

To communicate with the main computer, the system provides a shared data space RAM [random access memory], and information exchange between the two computers is accomplished via the bus. The main computer, the single-chip computer, and the shared data space constitute the distributed multi-computer processing system^[11]. The main computer receives data from the ground interface and stores them in the shared RAM; the 8749 chip retrieves the data and inserts them in order of priority into the buffer queues of its internal RAM, then transmits the data to the synchronizer under interrupt control. Data from other stations (including data originated by the local station) are also received by the 8749 computer via the synchronizer; after identification and processing, they are stored in the shared RAM in tabular form, where they can be retrieved by the main computer. In order to ensure mutual exclusion between the main computer and the 8749 computer when visiting the shared RAM, the system provides three bus isolators, a pair of hand-shake signals as well as resource competition control signals (transmitted by the 8749 chip via the I/O port). To maintain the interlocking action during resource competition and to avoid loss of lock during contention caused by delay in the hand-shake signal, a decision rule must be implemented in the software design. Test results show that a reliable decision rule is to require three consecutive success votes in the main computer to declare success, and only one success vote in the 8749 computer to declare success.

Because of the real-time requirement of the transmitted signals from the synchronizer, the 8749 computer must transmit data in the interrupt mode in order to maintain the integrity of data transmission. The receive number control signal from the synchronizer is stored in the locking storage unit. Since the common channel operates in the TDMA mode, the timing at each station

is accurately determined by the timing reference subframe. Once the "reference subframe arrival" signal is received by the 8749 computer, its internal timer is activated so that the local-station code can be correctly identified (i.e., the timing gaps of each TDMA subframe). The reference-station sync-loss signal transmitted from the synchronizer to the 8749 chip is a voltage signal which is connected to the test port T0 of the 8749 chip. If sync-loss is detected, then a control signal is transmitted through the 8749 I/O port to cause inversion between the reference station, the backup reference station, and the operating station to ensure that timing of the whole network is preserved.

4. Software Design

4.1 Basic Considerations in Software Design

4.1.1 Software Functions

The software of the 8749 single-chip computer is designed to perform the following functions:

- A. real-time processing of each CSC-TDMA frame;
- B. real-time transmission of various units of information during the time gaps of local-station transmission, including:

- telephone instruction signals from the main computer
- local-station busy signals generated by the system
- broadcast information indicating busy status of the system terminal;

C. real-time processing of reference-station sync-loss information from the synchronizer;

D. real-time processing of the "reference subframe arrival" information from the synchronizer;

E. presetting of parameters within the range of performance specifications (station code, number of relay circuits, local-station characteristics, etc.).

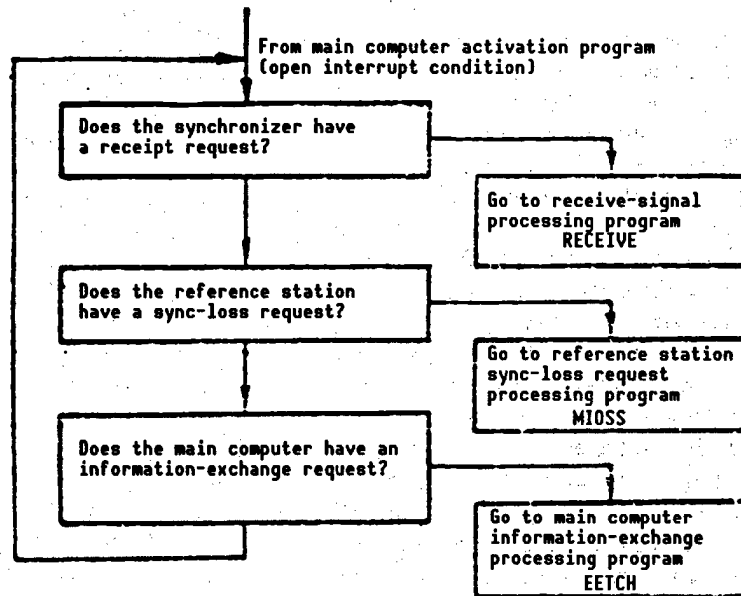

Figure 3. Block Diagram of the Main Program

4.2 Software Design Methodology

4.2.1 Main Program, Interrupt Transmission Program and 8749-to-Main Computer Software Interface program

After the system completes the procedure of computer activation, self-test and parameter preset, it enters the main program. Under open interrupt conditions, the main program polls the possible entry ports of all the modules.

The block diagrams of the main program, the interrupt transmission program and the software interface program are shown in Figures 3, 4, and 5, respectively.

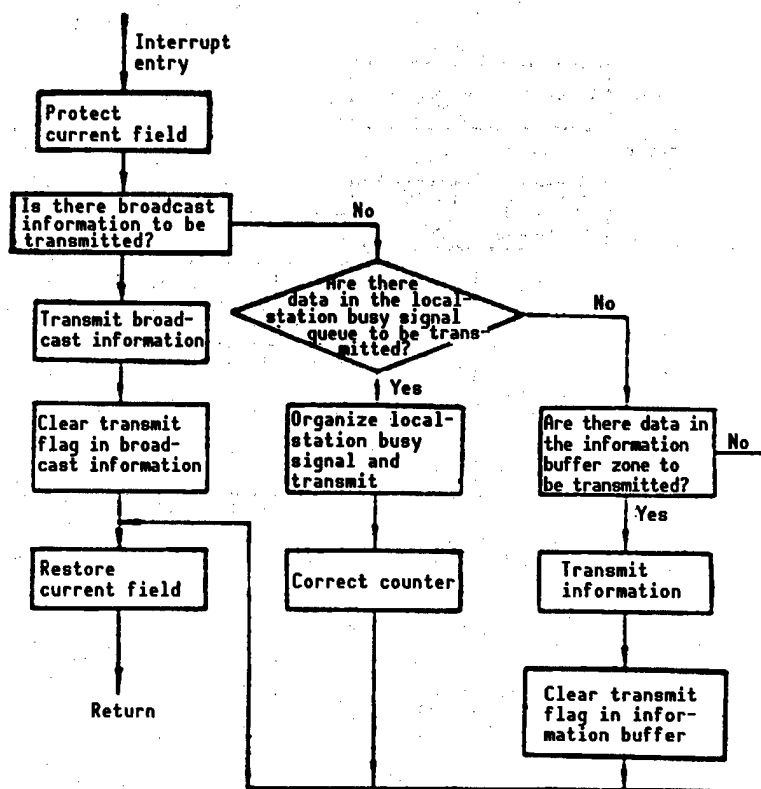

Figure 4. Block Diagram of the Interrupt Transmission Program

4.2.2 Processing Scheme for Establishing and Terminating Communications

For a network with decentralized control, each station can establish communications with any other station (including the local station) in the network. In this system, the information related to the local station is collected and stored in tabular form in the shared RAM. Thus, based on the strength channel number and the relative position in the table, the computer can easily identify the contents of the corresponding instruction, which greatly simplifies the software design. The construction and deletion of the instruction table are carried out dynamically, which reduces the storage requirement in the shared RAM. This feature is of particular importance in a network with many stations and interrupt circuits.

In order to increase the speed of signal search and processing, the number of visits to the shared RAM should be kept to a minimum. Within the 8749 computer, a special table control module is set up in the RAM; each table-control word occupies a two-byte memory space, as shown in Figure 6.

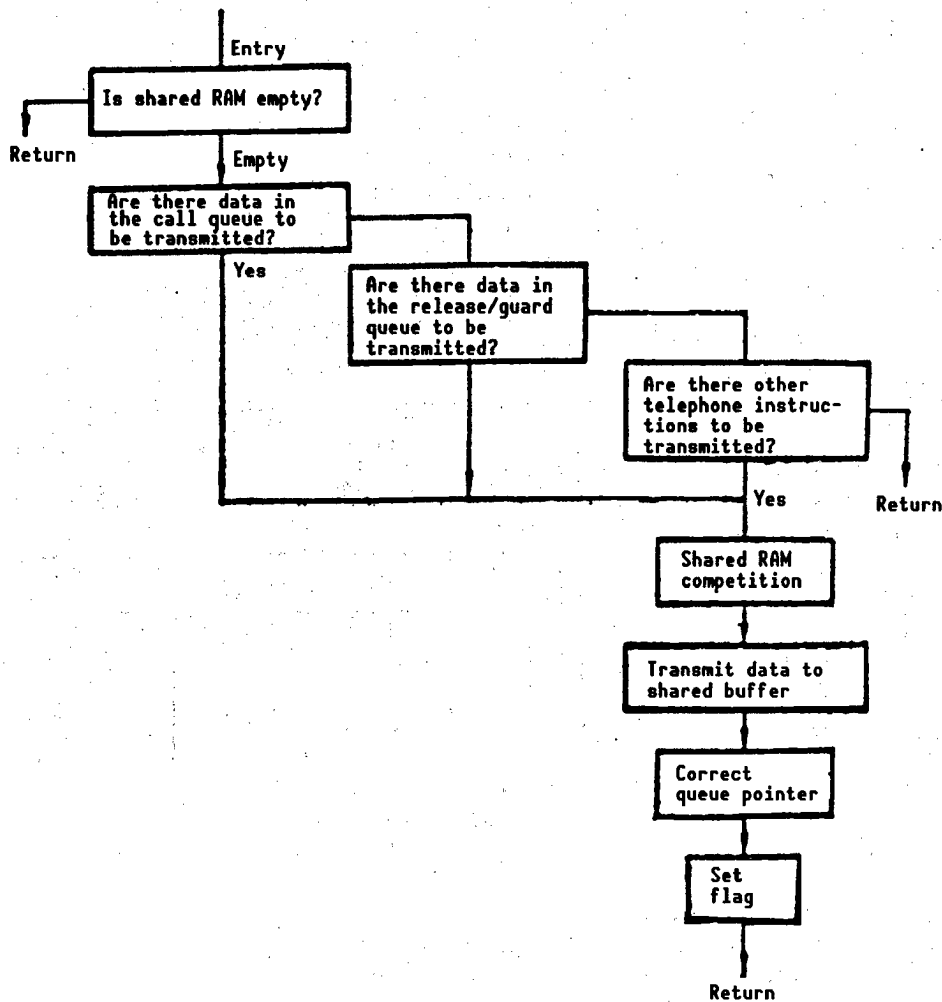

Figure 5. Block Diagram of Single-Chip Computer to Main Computer Software Interface Program

As an example, the establishment and termination of communications at a called station is briefly described.

A. Once a call is received, the system searches for an idle table in the table-control module.

B. If one is found, then a flag is set to indicate that the table is now busy and to acknowledge that a call has just been received; the satellite channel number is also recorded.

C. If no idle table is found, then it searches for a table with a flag indicating that a call has just been received.

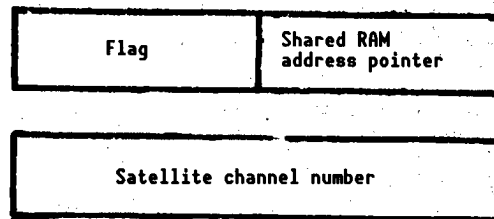

Figure 6

D. If none can be found, then it prepares to transmit the local-station busy signal by placing the calling station code and the satellite channel number in the corresponding transmit queue, and begins transmission when the interrupt signal arrives.

E. If a table is found, then it searches for a contention flag in the shared RAM (see 4.2.3). If contention occurs, then it covers this table with new calling information and records the information in the RAM control module inside the 8749 chip (see B); if contention does not occur, then it goes to D.

F. After receiving the release/guard information originated from this station, it finds the control word of this table based on the satellite channel number, and sets a cancel flag at the proper location.

Test results show that the use of a table control module greatly reduces the number of visits to the shared RAM by the 8749 chip.

4.2.3 Contention Processing Scheme

The single-hop time delay in satellite communications is approximately 250 ms; during this time, two or more stations may select the same channel to initiate their calls. By using random channel selection, the contention probability may be reduced, but the possibility still exists. To avoid two or more stations using the same frequency for communications, the following measures should be implemented at both the receiving end and the transmitting end.

Transmitting end

- A. The main computer randomly selects an idle channel and initiates the call.
- B. A temporary storage flag is set for this channel.
- C. Determine the busy/idle status of the channel after receiving the transmitted signal.
- D. If the channel is busy, then the call has failed; prepare for the next call.
- E. If the channel is idle, set a busy flag in the channel busy/idle table to indicate that the line is occupied.
- F. Wait for a response from the other party.
- G. If the response indicates non-busy status, then the call has succeeded.
- H. If the response indicates busy status, then transmit the release-guard information for this channel.
- I. Upon receiving this information, the channel is released by the 8749 computer.

Receiving end

- A. The main computer receives the calling signal from the shared RAM.
- B. Determine the busy/idle status of the calling channel.
- C. If busy, then contention has occurred, and the call has failed; notify the 8749 computer to delete this channel.
- D. If not busy, then a link has been established; prepare to receive subsequent instructions.

4.2.4 Broadcast Information Processing Scheme

An important consideration in the design of a communications network is the robustness of network organization. Also, to effectively carry out the dynamic allocation of satellite channels and to minimize artificial blockages, the system is required to broadcast timely information on the busy/idle status or blockage status of the channels and the terminals.

The broadcast information indicating the satellite channel status is contained in the terminal voice channels; when each terminal receives the calling signals from other stations, it automatically sets a busy flag in the satellite channel busy/idle table. The broadcast information indicating that the satellite channel has changed from busy to idle is contained in the release-guard signal of the voice channel; when the terminal receives the release-guard signal, it sets the idle flag for this channel. If the calling station transmits a non-contention signal to a busy or blocked terminal and receives a busy response, it immediately transmits a release/guard signal to release the channel occupied by this call.

The busy, idle, and blockage signals are only sent when there is a change in the busy/idle status of the local station.

A system that has just entered the network can immediately participate in effective communications after it receives all the broadcast information. A system that is leaving the network must first transmit a signal indicating busy or blockage status of the local station in order to avoid futile calls from other stations.

4.2.5 Data Structure

The data organization in the RAM should be designed to maximize system efficiency. The data structure in the buffer is in the form of a tree, as shown in Figure 7. The data flow in order of descending priority is from left to right. The information in each queue is transmitted according to the first-in first-out (FIFO) mode.

The received data are stored in the buffer in tabular form; the table control module within the 8749 RAM provides the pointers and flags to facilitate the search process.

The initial execution of the 8749 program is assured by the charged delay reset circuit and the computer-enforced set and reset operations.

5. Concluding Remarks

This article presents a detailed description of the structure and performance of the CSC-TDMA IPS of the DAMA communications system developed by the MPT. This system uses distributed multi-processors with parallel-processing capabilities. The IPS is an independent module which preprocesses the information entering the main computer, thus greatly reducing the requirements imposed by the SCPC-DAMA system on the main computer. The hardware interface signal is generated by software, thereby simplifying the interface circuit of the common channel synchronizer. The feasibility of the design concept has been demonstrated by the low cost and superior performance of this system.

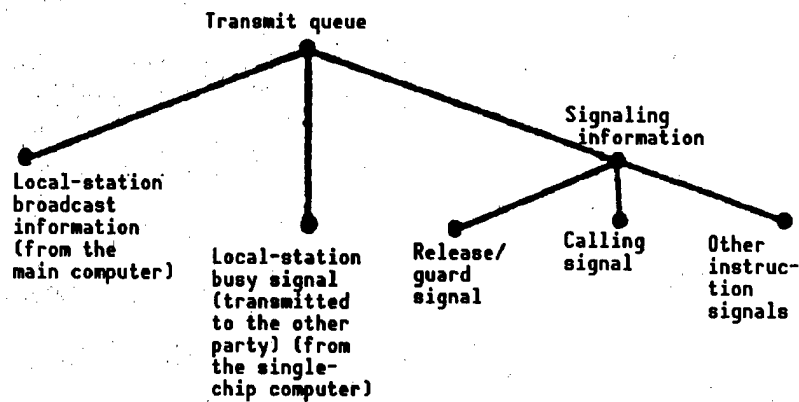

Figure 7

References

1. A.M. Werth, "SPADE A PCM FDMA Demand Assignment System for Satellite Communication," in Proc. ICDCS-1 London, Nov 1969.
2. D.W. Lipke, et al., "MARISAT-A Maritime Satellite Communications System," COMSAT TECH. REV., Vol 7, Fall 1977.
3. J. Salomon, "FASTOM: Small Rural Communication Satellite Earth Station," COMMUTATION & TRANSMISSION, No 4, 1986, pp 13-28.
4. J.G. Puente and A.M. Werth, "Demand-Assignment Service for the INTELSAT Global Network," IEEE SPECTRUM, Vol 8, Jan 1971, pp 59-69.
5. E.R. Cacciamani, "The SPADE System as Applied to Data Communication and Small Station Operation," COMSAT TECH. REV., Vol 1 No 1, Fall 1971.
6. B.I. Edelson and A.M. Werth, "SPADE System: Progress and Application," Ibid., Vol 2 No 1, Spring 1972.
7. A. Bairi and J. Leonhard, "A Domestic Satellite Communications System for Algeria," IEEE 1975, International Conference on Communication, Vol 1, pp 13-23-27.

8. Arnold ph. Djiwatampn, "PALAPA-The Indonesian Domestic Satellite Communications System (SKSD)," AIAA 7th Communication Satellite System Conference, Apr 24-27, 1978, pp 582-589.
9. James Martin, "Communications Satellite Systems," Prentice-Hall, Inc., 1978.
10. Radio Communications Handbook, 1988, No 2.
11. Jin Lan, et al., "Structure of Parallel-Processing Computers."

- END -

NTIS
ATTN PROCESS 103

2

5285 PORT ROYAL RD
SPRINGFIELD VA

22161

This is a U.S. Government publication. Its contents in no way represent the policies, views, or attitudes of the U.S. Government. Users of this publication may cite FBIS or JPRS provided they do so in a manner clearly identifying them as the secondary source.

Foreign Broadcast Information Service (FBIS) and Joint Publications Research Service (JPRS) publications contain political, military, economic, environmental, and sociological news, commentary, and other information, as well as scientific and technical data and reports. All information has been obtained from foreign radio and television broadcasts, news agency transmissions, newspapers, books, and periodicals. Items generally are processed from the first or best available sources. It should not be inferred that they have been disseminated only in the medium, in the language, or to the area indicated. Items from foreign language sources are translated; those from English-language sources are transcribed. Except for excluding certain diacritics, FBIS renders personal names and place-names in accordance with the romanization systems approved for U.S. Government publications by the U.S. Board of Geographic Names.

Headlines, editorial reports, and material enclosed in brackets [] are supplied by FBIS/JPRS. Processing indicators such as [Text] or [Excerpts] in the first line of each item indicate how the information was processed from the original. Unfamiliar names rendered phonetically are enclosed in parentheses. Words or names preceded by a question mark and enclosed in parentheses were not clear from the original source but have been supplied as appropriate to the context. Other unattributed parenthetical notes within the body of an item originate with the source. Times within items are as given by the source. Passages in boldface or italics are as published.

SUBSCRIPTION/PROCUREMENT INFORMATION

The FBIS DAILY REPORT contains current news and information and is published Monday through Friday in eight volumes: China, East Europe, Central Eurasia, East Asia, Near East & South Asia, Sub-Saharan Africa, Latin America, and West Europe. Supplements to the DAILY REPORTs may also be available periodically and will be distributed to regular DAILY REPORT subscribers. JPRS publications, which include approximately 50 regional, worldwide, and topical reports, generally contain less time-sensitive information and are published periodically.

Current DAILY REPORTs and JPRS publications are listed in *Government Reports Announcements* issued semimonthly by the National Technical Information Service (NTIS), 5285 Port Royal Road, Springfield, Virginia 22161 and the *Monthly Catalog of U.S. Government Publications* issued by the Superintendent of Documents, U.S. Government Printing Office, Washington, D.C. 20402.

The public may subscribe to either hardcover or microfiche versions of the DAILY REPORTs and JPRS publications through NTIS at the above address or by calling (703) 487-4630. Subscription rates will be

provided by NTIS upon request. Subscriptions are available outside the United States from NTIS or appointed foreign dealers. New subscribers should expect a 30-day delay in receipt of the first issue.

U.S. Government offices may obtain subscriptions to the DAILY REPORTs or JPRS publications (hardcover or microfiche) at no charge through their sponsoring organizations. For additional information or assistance, call FBIS, (202) 338-6735, or write to P.O. Box 2604, Washington, D.C. 20013. Department of Defense consumers are required to submit requests through appropriate command validation channels to DIA, RTS-2C, Washington, D.C. 20301. (Telephone: (202) 373-3771, Autovon: 243-3771.)

Back issues or single copies of the DAILY REPORTs and JPRS publications are not available. Both the DAILY REPORTs and the JPRS publications are on file for public reference at the Library of Congress and at many Federal Depository Libraries. Reference copies may also be seen at many public and university libraries throughout the United States.