

071073

JPRS-UCR-86-002

17 January 1986

# USSR Report

CONSTRUCTION AND RELATED INDUSTRIES

19980507 152

**FBIS** FOREIGN BROADCAST INFORMATION SERVICE

REPRODUCED BY  
NATIONAL TECHNICAL  
INFORMATION SERVICE  
U.S. DEPARTMENT OF COMMERCE  
SPRINGFIELD, VA. 22161

**DISTRIBUTION STATEMENT A**  
Approved for public release;  
Distribution Unlimited

8  
72  
A04

#### NOTE

JPRS publications contain information primarily from foreign newspapers, periodicals and books, but also from news agency transmissions and broadcasts. Materials from foreign-language sources are translated; those from English-language sources are transcribed or reprinted, with the original phrasing and other characteristics retained.

Headlines, editorial reports, and material enclosed in brackets [ ] are supplied by JPRS. Processing indicators such as [Text] or [Excerpt] in the first line of each item, or following the last line of a brief, indicate how the original information was processed. Where no processing indicator is given, the information was summarized or extracted.

Unfamiliar names rendered phonetically or transliterated are enclosed in parentheses. Words or names preceded by a question mark and enclosed in parentheses were not clear in the original but have been supplied as appropriate in context. Other unattributed parenthetical notes within the body of an item originate with the source. Times within items are as given by source.

The contents of this publication in no way represent the policies, views or attitudes of the U.S. Government.

#### PROCUREMENT OF PUBLICATIONS

JPRS publications may be ordered from the National Technical Information Service (NTIS), Springfield, Virginia 22161. In ordering, it is recommended that the JPRS number, title, date and author, if applicable, of publication be cited.

Current JPRS publications are announced in Government Reports Announcements issued semimonthly by the NTIS, and are listed in the Monthly Catalog of U.S. Government Publications issued by the Superintendent of Documents, U.S. Government Printing Office, Washington, D.C. 20402.

Correspondence pertaining to matters other than procurement may be addressed to Joint Publications Research Service, 1000 North Glebe Road, Arlington, Virginia 22201.

Soviet books and journal articles displaying a copyright notice are reproduced and sold by NTIS with permission of the copyright agency of the Soviet Union. Permission for further reproduction must be obtained from copyright owner.

17 January 1986

USSR REPORT  
CONSTRUCTION AND RELATED INDUSTRIES

CONTENTS

CONSTRUCTION PLANNING AND ECONOMICS

Uses of Solar Power in Buildings Discussed (N. Selivanov; ARKHITEKTURA, No 25, 16 Dec 84).....	1
Changes in Educational Structure Proposed (Yu. Zhdanov; ARKHITEKTURA, No 25, 16 Dec 84).....	13
Review of Doric Order in Greek Architecture (A. Skvortsov; ARKHITEKTURA, No 25, 16 Dec 84).....	16
Architecture for New Department Store Critiqued (V. Dvoryashin; ARKHITEKTURA, No 25, 16 Dec 84).....	21
Plans for Schools in Bulgaria Detailed (R. Kyupribasheva; ARKHITEKTURA, No 25, 16 Dec 84).....	25
Plenum of RSFSR Union of Architects Held (Yu. Yevsikov; ARKHITEKTURA, No 25, 16 Dec 84).....	30
New Mausoleum Erected in Azerbaijan (ARKHITEKTURA, No 25, 16 Dec 84).....	31
1984 Architectural Laureates Listed (ARKHITEKTURA, No 25, 16 Dec 84).....	33
Tajik Architects' Conference Held (ARKHITEKTURA, No 25, 16 Dec 84).....	34
Reconstruction and Restoration of Old Villages (ARKHITEKTURA, No 25, 16 Dec 84).....	35
Role of Art and Architecture in Urban Planning (A. Amirkhanyan; ARKHITEKTURA, No 25, 16 Dec 84).....	36

Architect Assesses Need for Vision in Planning (A. Isayev; ARKHITEKTURA, No 25, 16 Dec 84).....	39
New Designs Reviewed (ARKHITEKTURA, No 25, 16 Dec 84).....	43
Architectural Approaches to Industrial Structures (L. Viktorova; ARKHITEKTURA, No 25, 16 Dec 84).....	46
Contest Held To Design Village (I. Eltman; ARKHITEKTURA, No 25, 16 Dec 84).....	51
Lead Editorial Reviews Investment, Reconstruction Policy (Editorial; EKONOMIKA STROITELSTVA, No 9, Sep 85).....	53
Table of Contents, EKONOMIKA STROITELSTVA, Oct 85 (EKONOMIKA STROITELSTVA, No 10, Oct 85).....	61
<b>CONSTRUCTION MACHINERY AND EQUIPMENT</b>	
Introduction of New, Heavy Construction Machinery Reported (EKONOMICHESKAYA GAZETA, No 25, Jun 85).....	63
Delays at Krasnoyarsk Heavy Excavator Plant Examined (V. Prokushev; PRAVDA, 30 Jul 85).....	64

CONSTRUCTION PLANNING AND ECONOMICS

USES OF SOLAR POWER IN BUILDINGS DISCUSSED

Moscow ARKHITEKTURA (PRILOZHENIYE K STROITELNAYA GAZETA) in Russian No. 25, 16  
Dec 84 pp 4-5

[Article by N. Selivanov, candidate of technical sciences: "Storehouses for Solar Heat, Concerning the Basis for Designing Active Energy Buildings"]

[Text] N. Selivanov, candidate of technical sciences and author of more than one hundred inventions in the field of construction heliotechnology including several dozen heliocomplexes with a high level of energy activity, gave a report at a conference on architectural bionics and helioarchitecture that was organized in Simferopol by the USSR Union of Architects. He formulated and corroborated by specific developments such new approaches in architectural and construction design as tracking type buildings, stationary buildings with a tracking collector, groups of buildings and engineering structures that form a single power ensemble in an external source field, and formulated the architectural and bionic principle of the sensitive reaction of buildings to the environment's energy situation. N. Selivanov expounds on several propositions in his work in this article.

The energy resources of the housing unit.... Can they be controlled by varying only the form and orientation of the modern rectangular building? Can the wind be induced to warm rather than cool a building in winter? Is it sufficient to install a solar collector for a housing unit to become energy efficient and comfortable? According to what rules and by what methods should a housing unit be designed to be truly energy efficient and ecologically comfortable and ready for a productive dialogue with the sun's energy and other sources of energy? These and other questions will be the subject of our discussion. The answers to them in total will form the basis for the architectural and structural design of energy efficient buildings.

If we construct a logical chain "purpose--means--result" and make ecological comfort as the main goal of architectural design for a dwelling's environment, then the energy sources of the housing unit should, without a doubt, be mentioned among the means for achieving this goal; a perfectly designed inhabited structure will be the result--ecologically comfortable and

economical in its consumption of energy (i.e., a building with a good energy balance).

A building loses heat through the exterior curtainwall and the more energy it has the greater its relative area (accepting it per unit of the building's volume). We shall call this the coefficient of exterior area. At present the most widely used plan for a building is rectangular. A building with a cubic shape has the smallest coefficient of exterior area (with an equal volume) of the many types of housing units. One other physical value will prove useful to us; the relation of the coefficient of exterior area (k.o.) for the arbitrary form of the building to the minimum k.o. that is equivalent to the volume in a cubic building. We will call this value the coefficient of non-compactness for the building's forms.

When designing a construction project for a microrayon the same usable volume of 94,500 cubic meters of heated buildings can be expressed in the form of ten twelve-story towers with dimensions of 15x15x42 meters or in the form of one combined building outline with dimensions of 12x187x42 meters. Simple calculations show that the first of these approaches has a coefficient of non-compactness for the form equal to 2.65 while the second is 1.83. This means that the different architectural approach of a combined building in the given case proved to be 44 percent more economical in terms of capital investments for curtainwall and for the consumption of materials that are in short supply: heat insulation, reinforcing steel, concrete, exterior slabs and, what is no less important, 44 percent more economical in the consumption of energy to heat during the entire time that the building is in use. And this, notice, is without any special contrivances, energy-trapping devices or other equivalent methods.

Now several questions that at first glance appear to be foolish. For what is a window in a building needed? Is a window always needed? And another--what kind of window should be in an energy-efficient housing unit? A window is functionally necessary in order to look through it and in order to illuminate the premises as long as there is one person in it. But who needs a window in a polyclinic at night that only operates during the day, in a day school or in an industrial building that has no people in it? From the point of view of the maker of the energy balance, the winter night, whether it be in Novgorod or in Yakutsk, a window is an ideal device for redistributing energy. Windows resist heat transfers less than blank sections of walls by a factor of 2.5 to 4. If there were no windows a building would lose 18 to 35 percent less heat energy during the night.

What should a window be? How can the window be further improved? The opinions of light and heat technologists are in direct contradiction. The former say let's increase the area of a window and reduce the number of layers of glass. It is advantageous from the standpoint of bactericides and erythema and there is more light to work. But in the opinion of heat technologists it is just the opposite; reduce the area of the window and give us a triple layer of glass!

Extreme approaches rarely contain a golden kernel of truth in them. And in this situation we will try to search for an answer dialectically--a window in an energy-efficient housing unit must be transformable. Domestic architecture never extensively used this method. Up to now they have been using removable frames with glass that are put in windows in winter and taken out in summer. This method has been retained, perhaps, only in suburban electric trains that move along railroad tracks but this is not done in stationary buildings.... The absurdity of the situation is especially obvious if you recall that no less than 10 inventions exist by the KievZNIIEP [Plant Scientific Research Institute for Experimental Design], the TsNIIEP [All-Union Scientific Research Institute for Experimental Design] for Housing and the TsNIIEP for Educational Buildings and other organizations that contain the answer to the question of how to transform a window in order to improve its energy efficiency. Among them are recommendations whose aim is to improve the resistance of a window to heat transfers to a level that is equivalent to the resistance of a blank exterior wall while simultaneously improving its noise-resistant characteristic (Diagram 1).

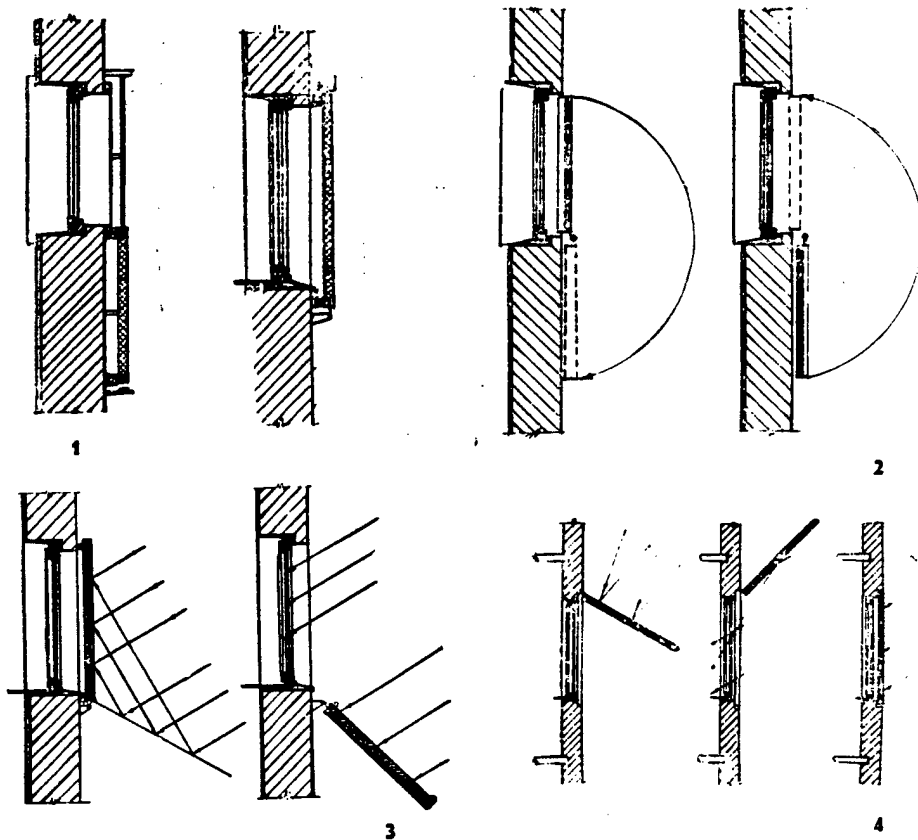

Diagrams 1-4 Energy-Conserving Components for Window Openings.

The aim of the other approaches is to improve light and energy activity during winter days; it is possible, for example, to trap solar energy by protective shields that can be transformed; they have a solar energy collector for this and, in addition to this, a reflecting screen that can be positioned (Diagrams 2-4).

Summing up the results of an examination of the expended portion of energy balance, it is possible, in this manner, to distinguish the most important main methods of improving energy efficiency:

- 1) developing more compact, in terms of exterior area, architectural approaches to the forms for designed buildings among those that are equally feasible, and,
- 2) improving the light and energy characteristics of windows and light passages in general on the basis of the principle of the geometrical and technical heat transformation of components.

The time has come to direct an equal flow of kilocalories in opposition to the kilocalories that leave the premises which can be mobilized by the rays of the sun, wind currents and the ground mass. It is necessary to do this by using methods that are adequate for the properties of an external energy field with which the components interact that are joined to the appropriate types of energy systems. The external sources must at first supplement the energy balance of the building and then later comprise the basis for its incoming portion. By considering the unprecedented development of solar energy at the given stage it is expedient to first of all examine, summarize and supplement the methods that are used for architectural design work when working out helioenergy active buildings.

It is difficult to give a broad idea of the comparative solar energy efficiency in all the various large numbers of buildings. It would be inadequate to rely on the generally accepted method of a localized evaluation of the entrance of solar radiation on a facade. It is necessary to also use an indicator for the corrected solar exposure of a building. This is the ratio of the average value of the solar energy to the area of all exterior curtainwall. It is useful to take a building in a cubic form as the standard of exposure (1). Further we will choose extreme buildings from the many rectangular ones: a narrow low-story building that is oriented and elongated along a meridian (2), the same type combined building (3), a modular section building that is developed in the plan view (4), two latitudinally-oriented buildings that are analogous to (2) and (3) and which are designated with an index of (5) for the building that is stretched out in a longitudinal direction and (6) for the combined building, and we will take a tower housing unit as the last extreme type (7). Having calculated the given solar exposure for buildings (1)-(7) during a cycle of a year and having divided it by the exposure of standard building (1) for the months we derive the heliotechnical record for the city (Diagram 5).



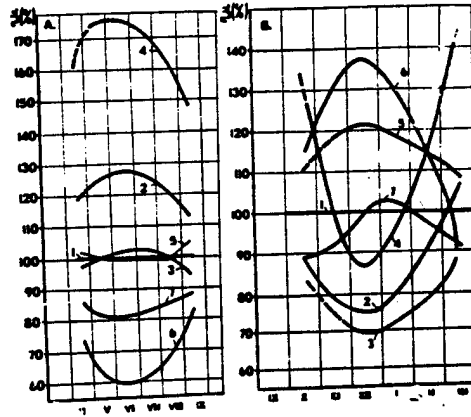

5

Diagram 5. Heliotechnical Record for a City.

The extreme range of possible changes in the solar energy potential of buildings is represented on such a record in undimensioned units. The spread of values vertically within the confines of each month characterizes the range of possibilities for an architect to vary the solar energy potential of the building being designed by changing the form or orientation of the latter. For example, the corrected solar exposure of a latitudinally-oriented combined building (6) in June can be less than a modular unit low-story industrial building that is developed in plan view (4) by a factor of 2.3. And by just changing the orientation from latitudinal to meridional can change the total amount of solar energy that a combined building receives on a sunny day in June by 60 percent.

Other graphic information about the seasonal and annual evolution of the corrected solar exposure of buildings can also be obtained from the heliotechnical record. For example, a meridionally-oriented combined building in the central latitudes of the country receives about 60 percent more solar energy during the summer than a latitudinally-oriented combined; yet during the winter it receives the minimum amount in comparison with buildings with other shapes. A combined building with a latitudinal orientation has a minimum amount of overheating in the summer yet the maximum amount of solar energy in the winter--in particular it is greater than a combined building (3) by a factor of 1.65.

Thus, we have answered yet another question that was formulated at the beginning of the article: it is possible to regulate the solar energy potential of buildings by architectural design means and to change it in the extremes by a factor of 2.5 and more.

Solar energy and its focused part disperse in space. In the final analysis, only the area of projection of a building's form that is on a surface perpendicular to the solar rays is important for collecting it through energy-active buildings. In addition, in order to keep the energy balance of a building at its optimum level it is necessary to simultaneously strive to minimize the emitting (heat liberating) surface. Of all the shapes of

buildings only a combined building can meet these two conditions with an acceptable compromise; "arches," "horseshoes," and "hooks" cannot compete with them in this respect. In particular, horseshoe-shaped buildings whose facade is oriented toward the south can only form favorable protection for the south facade against winter winds and in the fall, winter and spring periods it can improve the microclimate of the courtyard that is protected by it--but at the price of a deficiency in solar energy for the building itself.

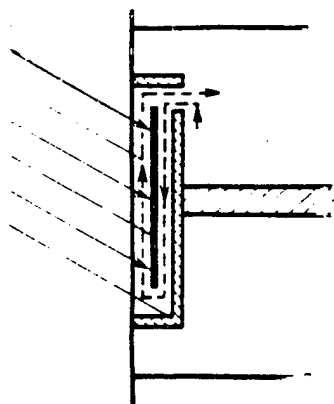
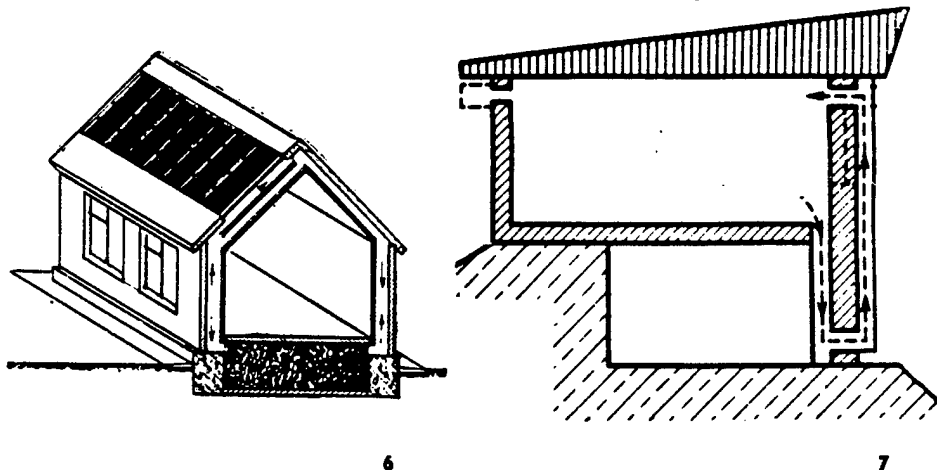

Diagrams 6-9. Architectural and Structural Approaches to Passive Solar Buildings

Of the two types of low-temperature collectors in extensive use which convert solar energy into heat by passive and active means the simplest in structural respects and most economical are the first (Diagrams 6 to 9). They are intended for low-story buildings and consist of blackened helioreceptacle--usually a concrete wall or metal sheet and the exterior glass that is separated from it by a layer of air--heliotraps that are, however, opaque for heat emanation by the warmed wall. The efficiency of "passive" systems is based on adopting the principle of a semifunctional design for energy-active components in buildings right from the start: the principle of combining the

functions of a heliodevice and a structural component in one and the same elements. A helioreceptacle as a load-bearing element of a wall; selective glazing on a collector used as a durable facing for a building's curtainwall. It is necessary to propagandize in every way possible precisely this principle and this design approach in all its different variations when designing new systems for energy-active buildings.

Active systems are supplemented by a heat exchanger with a liquid heat carrier that has a greater capacity for containing energy frequently with the forced circulation of the latter. These are more general purpose systems but at the same time they also consume more labor and materials and have a higher cost. The primary way to improve their efficiency in buildings is contained in reducing their relative area and improve their thermal output through supplying them with concentrated streams of solar energy by means of a system of focused reflectors.

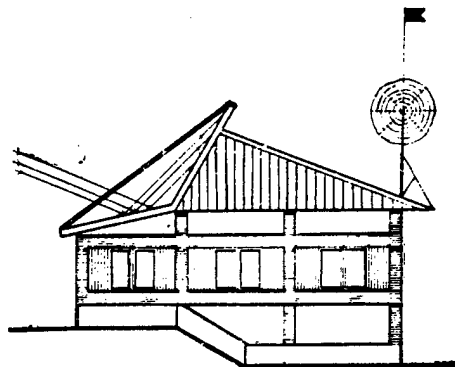

10

Diagram 10

An energy-active building with an active type of solar collector which was developed in the USSR is shown in Diagram 10. The collector is mounted into a sloping roof in the form of a panel that is turned toward the sun and inclines inwardly dividing the attic into two compartments: one exposed to the sun's rays and one darkened. The collector is supplemented below by a focused reflector that is connected to it. The reflector is made in the form of a horizontally or completely inclined upper layer on the attic roof. A feature of the structural approach to this building is the fact that the collector and reflector are protected from dirt, snow loads and ice by a common translucent glass ramp.

A collector must be located on a building in such a manner that provides maximum exposure to the field of solar rays. In such a manner the collector is provided the maximum solar energy resources. And it is precisely for this reason that during the course of the first decades of experimentally developing solar energy-active buildings that active type collectors were placed on the southern slope of a roof. This scheme that was worked out as an

architectural approach can be retained chiefly in rural construction in low-story cottages and single-bay industrial buildings.

With the transition of solar energy to low-story housing units and public buildings as well as modular-section industrial buildings that are designed in the form of parallel rows or deliberately arranged so that the area of the exterior that is exposed to the sun's rays is not optimum a new architectural approach to a solar collector emerged. In order to meet the conditions for optimum exposure it is expedient to make a collector in discontinuous folds arranging the energy-active slopes of the folds in one way--at an angle that is optimum to sun (Diagram 7 [16?])

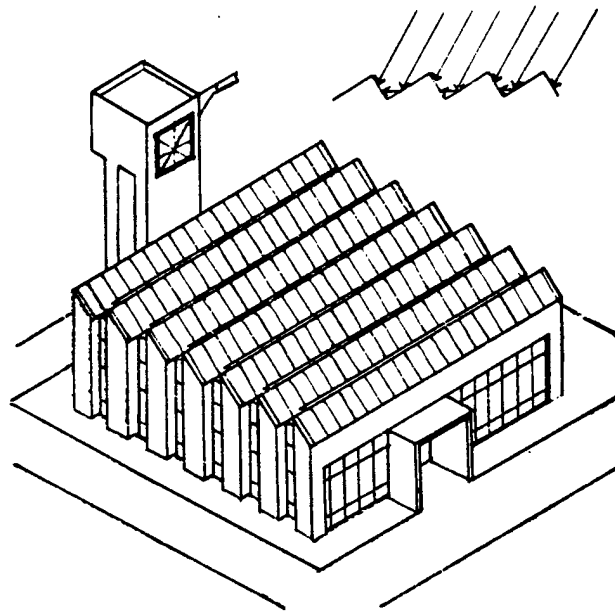

16

Diagram 16

This eliminates the primary contradiction between the mutually exclusive requirements of the sloped placement of energy-active exteriors (maximum solar energy potential and minimum area for the collector) and purely architectural requirements.

The modern arsenal of architectural and structural methods makes it possible to combine active and passive type collectors with any type of building exteriors: walls that are oriented toward the sun, exteriors that have balconies and verandas (Diagrams 11, 13, 15), on a building's basement or even locate it on a southern slope below the basement (Diagram 12), or independently on a horizontal lot in front of the building (Diagram 14).

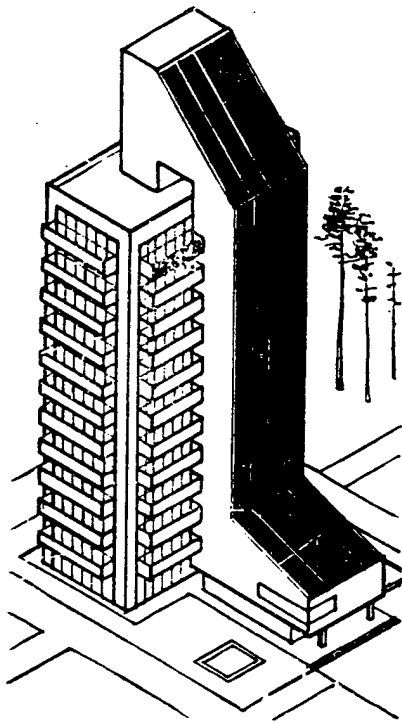

11

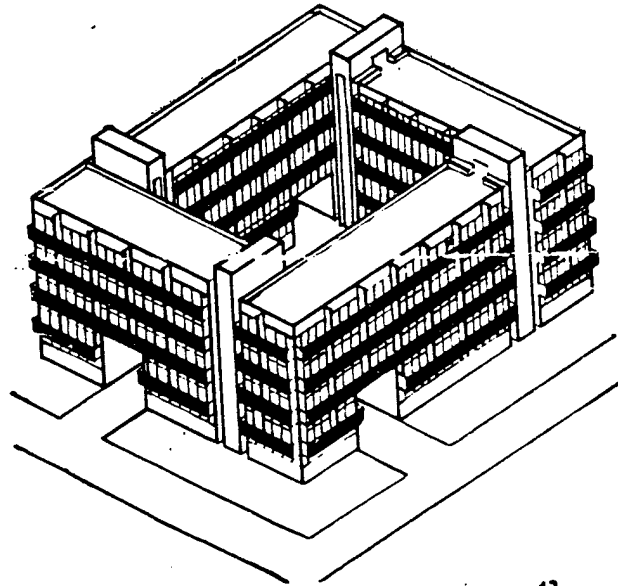

13

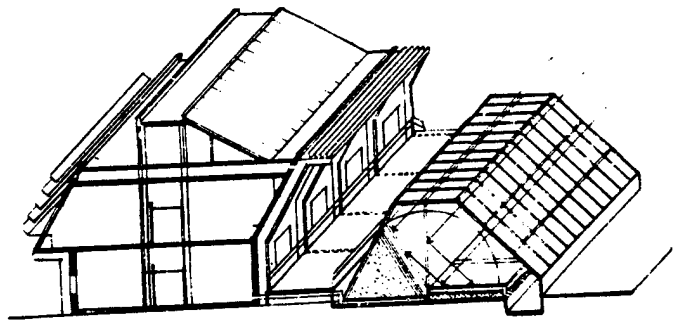

14

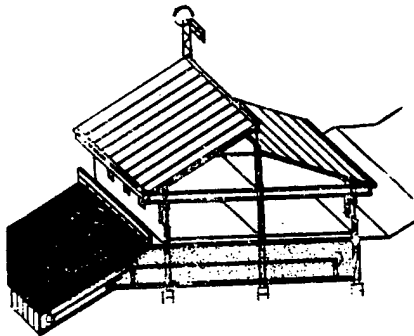

12

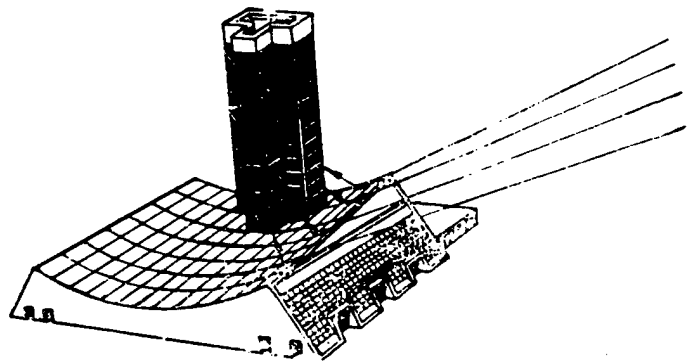

15

Diagrams 10-16. Different Architectural Approaches to a Solar-Energy Collector.

What should the architectural shape of the modern solar energy efficient building be? Diagram 17 shows the complex use of two methods--combining structures for various purposes in one building and a supplemental supply of solar energy to it through a system of exterior screens. There is a commodity warehouse located on the first floor (underground or semi-underground) with a boiler room or a farm for raising mushrooms with a separate exit and a courtyard terrace near one of the end facades. The second floor is above ground. A shop for processing agricultural products, a livestock area, or any other production work or everyday service enterprise can be located in it. The upper floor with translucent enclosure components can be a cultivation building.

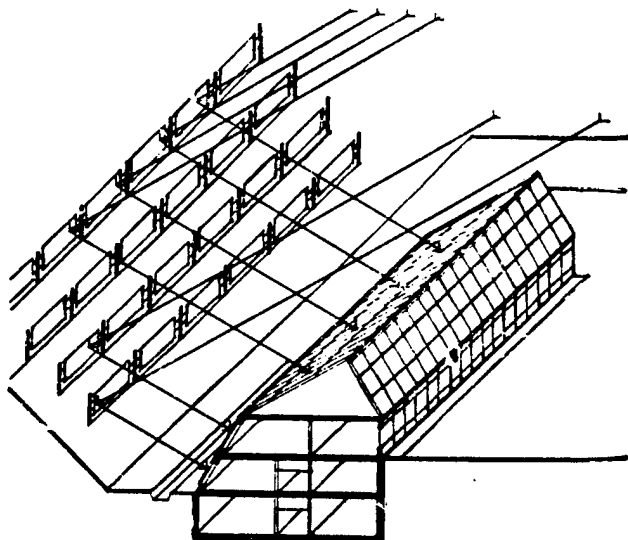

17

Diagram 17

Combining three structures that were separated previously provides a double gain by means of reducing the consumption of materials, the amount of work and the labor consumption for it. And the main one is that the heat energy that is lost in the production area (the above ground floor) is then used a second time for heating the cultivation building. The system of exterior screens that creates a supplemental source of solar energy for the cultivation building and other heliocreceptacles in the building improves the yield of the crops that are grown in it. At the same time the deficit in the energy balance of the building can be compensated for with the aid of such an architectural and structural method and it can be designed for drier climatic conditions.

Other architectural compositions can be designed instead of a production

building based on a similar heliotechnical scheme; for example, a school with production workshops and a physical education area on the lower floor and a winter garden on the upper, a sanatorium or combined children's nursery and kindergarten with a winter garden and solarium above. During the summertime when the sun is high and there is a surplus of sun, the exterior screens on the southern incline can additionally irradiate the bushes in the vineyard that are planted in front of it or other crops that like sun with reflected solar energy. Finally, it can serve as an open solarium and dispensary to provide accelerated tans for those that are on vacation or to increase the effect of solar heat baths during a period when the weather is relatively cool.

One of the basic conclusions is that it is possible to improve the ecological comfort of the living environment and at the same time improve the energy-efficiency of a building by one and the same means. By increasing energy protection--resistance to heat transfer and protection against the unfavorable influence of exterior fields--we simultaneously ensure a reduction in a building's energy consumption and, as a result, by burning less fuel we reduce the pollution of the biosphere.

And now we will answer one of the questions that was posed at the beginning of the article. Different architectural, urban development and engineering approaches for efficiency in a housing unit are adequate in Tashkent and Arkhangelsk for one and the same energy influences in total solar radiation and exterior air temperature but having different dosages during the winter and summer periods. A combined building having a latitudinal orientation has the best solar energy potential for central and southern latitudes in the country based on summer and winter conditions. However, the optimum architectural and urban development approach for the north and for regions that border on the Arctic Circle is in the form of a combined building with a meridional orientation which at the same time meets modern requirements for insulation standards in apartments that are oriented on two facades.

There was one more question about the installation of a solar collector. No, it will not automatically make a building energy efficient. It is necessary to carefully analyze all the incoming and outgoing component parts of the energy balance of a building each time and to use architectural design means that are adequate for it on the whole. A building can even be heated by wind, by the earth itself on which it stands and a reservoir that is near to it can supply energy.

More detailed working information on the problem of using solar energy and other types of renewable sources of energy in buildings is presented, in particular, in "Methodical Instructions for Designing Energy Efficient Buildings."\*

Subsequent stages and directions in the development of architectural and structural heliotechnology and improving the energy efficiency of solar

---

\* VILS. Developments by N. P. Selivanov and V. N. Spirov.

buildings can be linked with the development of tracking systems, with buildings that can undergo seasonal or other transformations and with the formation of energy interdependent groups of buildings--construction heliocomplexes. The result might be the discovery of basic tendencies in the evolution of the architectural form and engineering approaches to new diverse energy-active buildings.

But today the time has arrived in our country for the final phase of construction on such large heliotechnical buildings as the "Solntse" experimental proving grounds in the USSR IVTAN [not further identified] near Makhachkala, the "Solntse" metallurgical combine near Tashkent, the Alushta Heliocomplex and the Crimean SES [radio and telegraph operating service] in the Ministry of Power and Electrification. Domestic structural heliotechnology is on the march. At the same time the formation and acceptance of helioarchitecture for energy-efficient buildings is undergoing a phase of active creative research which today can be viewed as the fastest growing branch of a long range and broader direction overall--architecture for energy-active buildings.

9495

CSO: 8344/1033



CONSTRUCTION PLANNING AND ECONOMICS

CHANGES IN EDUCATIONAL STRUCTURE PROPOSED

Moscow ARKHITEKTURA (PRILOZHENIYE K STROITELNAYA GAZETA) in Russian No. 25, 16  
Dec 84 p 6

[Article by Yu. Zhdanov, architect: "To Forsee and to be Aware of Means to Economize; Reflections About Specialized Educational Centers for Children"]

[Text] Why centers? What has become of "traditional" specialized kindergartens and schools? Why are new types of structures needed? These questions are becoming urgent in association with the impending stage of new construction for institutions that teach children who have hearing deficiencies.

Questions concerning the social effectiveness and advisability of this or that type of institution have always troubled the minds and hearts of architects who, when fulfilling a certain social demand, rely on the requirements of teachers and many other specialists. But, forgive me teachers if I say that it is the architect himself who predetermines the possibilities and limits for improving the educational and training process in his designs. For the approved architectural and planning structure, the quantity and quality of the make up of the facilities and the entire architectural environment of the institution practically determines the conditions of the flow and changeability (more accurately the inability to change) of the entire educational and training process. And if an architect relies on the standard opinion about today's school in his work then his designs will be outmoded under the best circumstances by 10 to 15 years, that is, the time required to work out and adopt any typical design in reality. A simple and optimistic conclusion follows from this: an architect should know what teachers will "want" to see in 10 years!

Thus, before beginning a discussion about the long-range typological architectural structure for a specialized children's institution we will note the basic directions in the development of the rehabilitation process: a goal-oriented differentiated approach to teaching and its further individualization through intensive medical and pedagogical influence on the child's personality from the age of two or three years, the development of realistic forms of continuity in preschool and school education, etc. Dynamism and structural development, saturation with various technical educational means and preventive measures will be characteristic of the

educational and technological structure on the whole. These directions have been reflected in the architectural and planning structures of kindergartens and schools to a more or less greater degree. But further development of the educational and training process in traditional typological architectural structures (the kindergarten and school) seem inadvisable.

Why? The question has many facets and I propose to divide it into several questions.

FIRST REASON WHY. Let's turn to history. The typological division of the kindergarten and school was legally approved in the twenties at the dawn of Soviet pedagogy that deals with hearing impairments when it had only begun along its way and all of the fundamental discoveries still lay in the future. But the problem of teaching such children is and remains urgent... and it was decided to accept the typology of general educational and training institutions.

SECOND REASON WHY. After 67 years of stormy development in Soviet pedagogy that deals with hearing impairments specific requirements for the educational and technological process emerged that caused the birth of an integrated structure for an educational center. Even today in the majority of boarding schools there are preschool departments with starting grades where children remain for one to three years from the age of five. In essence this is a kindergarten. And although under actual conditions schools have adapted to this in different ways they have similar problems: the functions of "crushing," insufficient facilities, and kindergarten graduates have to catch up. And, yes, the kindergarten has now become an educational institution in the full sense of the word. Today a daily classroom is needed for each 12 children, as well as a classroom for individualized studies and specialized rooms. Therefore, one of the foundations for merging the typological architectural structures of the kindergarten and school is to make the principles of the architectural construction of the structures themselves conform more closely to the make-up of their facilities.

THIRD REASON WHY. Expenditures for a specific type of institution always corresponds to the level at which society has developed. For example, today we must already increase the standard for the space needed for one child almost by a factor of 1.7 in comparison with the standard for the typical design (1978) in order to meet the requirements for the new program for special preschool institutions. In addition, the maximum capacity of a kindergarten has to be lowered to 60 children in order to reduce the radius of service. But the standard for space in such a kindergarten will be greater than the previous typical design by a factor of 2.5. Are such expenditures justified? Hardly. This lack of correspondence between what is required and what is possible is also stimulating the emergence of a more progressive typological structure that integrates the kindergarten and school structure into a single unit while keeping the "degree of freedom" and administrative autonomy that is required for them today.

Cooperation between units in the structure makes it possible to additionally introduce a series of new sections: a water hygiene section, an individual

audio or scientific methodological and consultation work section, etc., and all of these have been accepted for specialized institutions within the limits of expenditures.

In conclusion, a small calculation. When utilizing, for example, 100 million rubles, we waste up to 20 percent of the funds in just this small section of the national educational system due to imperfections in the "traditional" typology of kindergartens and schools. But let's forget gloomy statistics. Today, on the basis of scientific research the first design developments have been made. A program of goals for developing typical designs for centers to accommodate 204 and 495 children and additions to existing specialized schools have been worked out through the direct participation of the author of this article. The goals have been reviewed and recommended for approval by the NII [Scientific Research Institute] for the Hygiene of Children and Teenagers and approved by the RSFSR Ministry of Education. These structures are included in the plan for typical design work for GIPROpros [State Institute for Design Requests] during 1985.

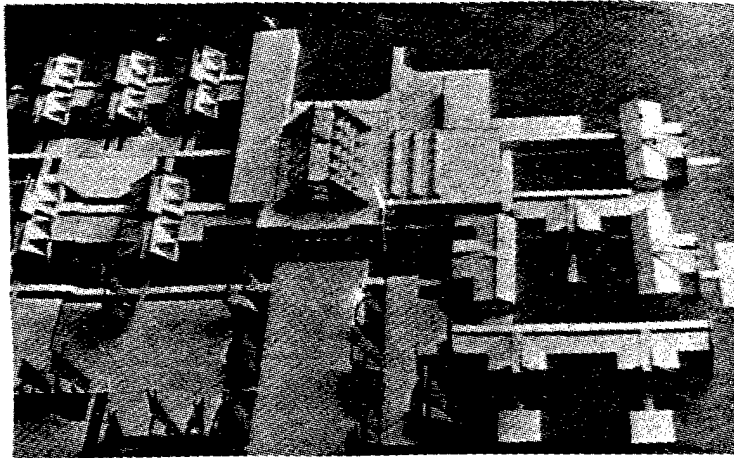

In the Photograph: A Specialized Educational Center.  
Author of the Graduation Design, V. Voznyuk

9495  
CSO: 8344/1033

CONSTRUCTION PLANNING AND ECONOMICS

REVIEW OF DORIC ORDER IN GREEK ARCHITECTURE

Moscow ARKHITEKTURA (PRILOZHENIYE K STROITELNAYA GAZETA) in Russian No. 25, 16  
Dec 84 p 8

[Article by A. Skvortsov, architect: "The Right of Artistic Deception;  
Concerning the Professional Cunning of the Ancient Masters"]

[Text] Voronezh--More than once, mankind, when looking at the past, has been guided by the achievements of preceding cultures in his stylistic arrangements. All epochs have in one way or another compared their ideological and artistic perceptions with the culture of antiquity--the point for measuring all of European civilization--whether or not classical principles were used totally, partially or rejected completely. Distant and magnificent, antiquity stimulated diverse and often contradictory ideas. The relationship of the Renaissance and Classicism epochs to it are well known. Frequently there are also periods when there are less significant "classical throwbacks," including during the 20th century. Even functionalism, which rejected any manifestation of an historical method, comes into contact with antiquity in the Socratic idea of the unity of function and beauty: "what is functionally useful is therefore beautiful."

Before us stands a majestic and magnificent Doric temple from the period when Greek art flowered--a universally recognized example of tectonic expressiveness and laconicism of architectural forms. Simply and visually organized, the self-supporting beam components form the basis for its artistic shape and the minimum amount of ornamentation and attempts at proportion and uncomplicated composition create a sense that it is monumental and in harmony. But this tectonic truthfulness is not at all as simple and plain as it seems at first glance. Quite a lot of professional cunning is hidden behind the idyllic exterior.

The level of understanding of the world is reflected in the forms of the architect that were born from a pantheistic consciousness just like in the mythology of the Greeks. Establishing a link between man and society, nature and the gods, architecture expresses the perception of the laws of the universe, and is the means for man to assert himself and elevate his intellectual genius to the level of the gods that in many ways are like man. The world view of the Greeks and the philosophical and aesthetic interpretation are clearly and visually revealed in the forms of architecture as the foundation for the physical world through the dramatic effect of the struggle of the supports with their loads.

The Doric order absorbed two different perceptions of harmony that ascended to the aesthetic ideals of the philosophical schools of the 6th century B.C.; the Pythagorean and Heraclitus schools. From the former it received mathematically regulated proportions, the solemn monumental form, the theme of the common struggle of the verticals and horizontals, the even and uneven numbers, the contrasting rhythm of the light columns against the dark background and so forth. From the latter it received the form of a living organism that is full of hidden dynamism with numerous violations of geometrical logic. The static struggle of the non-load-bearing and load-bearing masses, which are distributed simply and "truthfully," are next to significant distortions (the need for optical correction?).

In essence there are no straight lines at all in the Doric temple (the Parthenon, the Gephyrion and others). The stylobate and the entire entablature with the roof have a prominent shape (curvature), the vertical stone supports are not standing vertically (they incline inward), immovable by nature, they are dressed in forms that depict almost the "living" strain of muscles (entasis and echinus). The elements of the column are given the names of the parts of the human figure: body (shaft), head (capital), skull (abacus), foot (embat) and on the whole the column recalls the proportions and manly beauty of the male body.

Two truths collide in the orderly forms. One is the efficiently simple structural approach; the other is a graphic and figurative metaphor. In the intrigue of their conflict exquisite harmony emerges. The presence of numerous "unjustified" deviations and even "errors" in the structures--the price of which is the most complicated technological execution--speaks more of the desire to be convincing of its good fortune and indisputable truthfulness than of the fact that it successfully and originally combines two contradictions in the order. The primary goal of architecture is ideal artistic and graphic expressiveness. How did they achieve this?

The figurative principle was defined by them to be descriptive artistic order and the entire structure of the temple's form which makes it possible to call it one of the basics in the creative method of the Greeks. The point being made is not just about the synthesis of sculpture, painting and architecture. The order itself as a symbol of tectonic truth appears to be nothing other than an image or decoration that is set against the form of the cella while "truth" is camouflage. This is supported by the fact of the relative structural independence of the order's shell from the cella and the diversity in the types of temples which are distinguished in essence only by the degree of their orderly appearance while the basic premises do not change.

Encircling the temple with columns is a tradition that comes from antiquity. The clay walls and roof overhang for protection against precipitation were strengthened by wooden posts. This function lost its importance with the extensive use of stone in construction. Already "decoration" itself comprises greater material and artistic value than the walls of the cella. It can be seen in the cross-section: order actually "carries" only itself and such massive columns and entablature are not required to support the roof (Diagram 1).

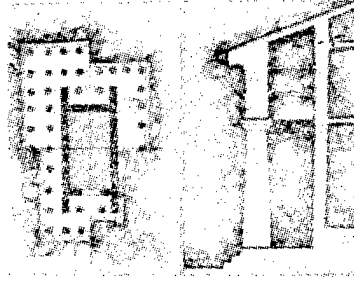

1

Diagram 1

The appearance of the Doric-type temple occurred under the influence of the tradition of the Mycenaean dwelling--the megaron; the anthropomorphism of religion became the basis for this. A mansion in a sacred grove was already the abode of a god and the word "naos" means both house and temple. The idea of surrounding the temple with sacred trees, from which, evidently, the attached supports were made, became conventionalized in the stone perimeter that preserved the stamp of sacredness and organic unity with nature (Diagrams 2,4).

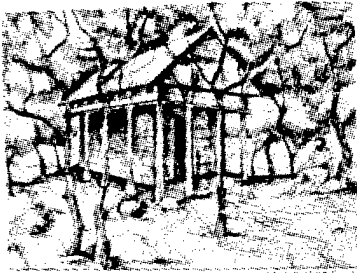

2

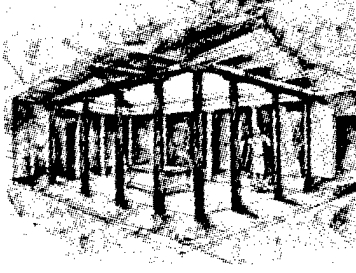

3



4

Diagrams 2-4

By its facade the megaron is turned inward with a courtyard containing a garden surrounded by a portico that attempts to isolate it from the outside world. The courtyard of the temple, on the other hand, has no boundaries. The portico is open to the world as a symbol of the omnipotence of the god and the openness to all. The temple, thus, appears to be a unique compositional negative to the megaron garden (Diagrams 3,4).

There exists two well-known theories about the origin of the Doric order. The first affirms that the order imitates its prototype--the archaic wooden structure. The other seems to affirm that the forms of the order were directly heuristically invented for stone which is credited to the Greeks. Supporters of the latter cite the fact that the geniuses of architecture, the Greeks, could not have stooped to the level of copying wooden forms in stone; triglyphs could not be the butt end of beams since they are on all four facades and are fluted while fluting wood across the grain is not effective and for the Greeks also inadmissible. However, these arguments give rise to doubts.

The consciousness of the ancients, more than ours, was strengthened by traditions that would not permit violations even with a change in the technology of construction. Observing the canons of form and proportion (within the limits of a certain amount of freedom) was more important to them than tectonic truthfulness. And this is a socially-conditioned artistic requirement that is inherent in any undiluted style.

Violle le Dyuk maintains that from the beginning the triglyphs, in their structural and graphic role, are vertical supports for the cornice and the fluting on them as well as on the columns serve as a sign of this. Therefore they follow the columns on all the facades. But such an explanation does not contradict the theory of the triglyphs as the butt end of the beams. First of all, the beam really fulfills two functions; it is a support and a covering. Secondly, why is it obligatory to consider the portico and the cella as being covered by the same beam? Is it true that short beams over the portico that are perpendicular to the walls of the cella are so illogical? The practicability of such an arrangement is supported by several temples with such a scheme for ceiling beams that have been preserved to our day (for example, the Gefestion in Athens). And fluting on the butt end of a wooden beam is no less appropriate than on a stone triglyph. In order to limit the hydroscopic nature of wood the butt end is roughened with an axe. It is possible that the fluting is simply the decorative fulfillment of this practical function.

The structural and tectonic structure that is depicted on the facades of the stone temples does not agree with reality. And this is not just because the triglyphs are not the butt ends of beams, the mutules are not facings for the trusses, the guttae are not wooden nails, etc.; all of this really has no practical significance in a stone structure. But also because the blocks from which the temple was assembled often do not coincide with the divisions of the forms that are depicted on the facades. Shuazi notes that "the stones in ancient temples are cut in such a manner that undoubtedly deserves criticism" (Diagram 5). These "blemishes" are masked by plaster while the joints of the individual blocks on the columns also have the ripples of fluting. The frieze in the temple to Poseidon in Paestum is divided into two rows of stonework "without any pangs of conscience." In the temples of the Akragant Concordia, to Heracles, Castor and the temple to Poseidon the triglyphs are cut in one square with metopes while the seams of the cornice are placed so irregularly that it sometimes occurs in the middle of a mutule. The architrave in the temples to Selinus and "Basilica" in Paestum which are square in section consist of two horizontal rows of stonework which contradicts the elementary logic of the components while the architrave in the temples to Zeus in Akragant is broken entirely into three rows. It not only does not support the roof but needs breastwalls between the columns for support.

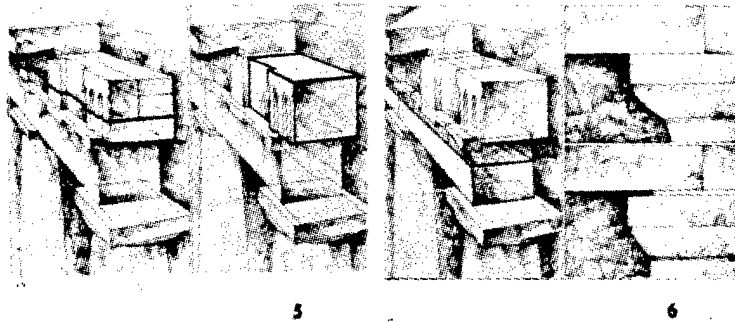

Diagrams 5,6

The transformation of the idea of the abacus in the Doric column into a purely decorative representation of itself is interesting (Diagram 6). The abacus really bears the load of the entablature and reduces the span between the columns only in the early temples. Its importance was already "forgotten" by the middle of the fifth century. The architrave stopped leaning on the overhangs of the abacus and was divided from it by a fissure that, evidently, was not just from fear of its cracking. And what about the "blasphemous" fact of coloring it with white marble or plaster "under marble"? Clay and limestone surfaces are plastered for the physical durability of the form and imitating stone creates the impression of longevity and expense.

The work appears, in this manner, to have apparent perfection, the pliable decoration reproduces tectonic forms and they are clearly striving chiefly for the artistic goals of visual truth (plausibility) to the detriment of structural goals. And although the obvious discrepancy between the real and figurative is evident, the Greeks, through the use of imitation, preserved that compositional and structural scheme that expressed the ingrained tradition of their perception of the laws of structures and the properties of materials and that express the epoch's perception of the world. The polar opposition of the two main features of architecture (structural and artistic) are suddenly transformed into cooperation and expressive unity that strives not so much to be what it depicts as to make the content of this image up to date in the best manner even if it is by means of artistic deception.

9495  
CSO: 8344/1033



CONSTRUCTION PLANNING AND ECONOMICS

ARCHITECTURE FOR NEW DEPARTMENT STORE CRITIQUED

Moscow ARKHITEKTURA (PRILOZHENIYE K STROITELNAYA GAZETA) in Russian No. 25, 16  
Dec 84 p 6

[Article by V. Dvoryashin, general director of the Rosrestavratsiya [Russian Restoration] Association and steemed cultural worker in the RSFSR:  
"Architectural Review; Alongside Masterpieces"]

[Text] Restorers always painfully accept the appearance of any new structure in the historical environment of a city. And while it may not have been with bayonets, we have, in any event, guardedly received the news about the construction of the largest department store in the country next to the Kazan train station. Two masterpieces of domestic architecture are right on Komsomol Square--a Shchusev symbiosis of Pre-Peter Moscow and Kazan architecture and an elegant variation of a Russian tower with a modernized treatment by F. Shekhtel--the Yaroslav train station.... In this regard it is curious to observe how were these two structures prepared to coexist? We will attempt to compare the incomparable--the architecture of the Kazan and Yaroslav train stations.

Nothing is similar. The square divides two concepts of architecture from approximately the same time period. Never having been enthralled with Russian modernism, A. Shchusev, as an intellectual architect in the largest urban development categories, tactfully treated the work of F. Shekhtel; he did not divert attention from the compact form of the Yaroslav train station but just the opposite--he placed the serene facades of the service buildings almost cornice to cornice with it emphasizing the affiliation of the structure to old Russian architecture with light window frames and band. The architect shifted the dominant feature of the complex to the corner as if he were gathering here, under the marquee of the tower, characteristic Moscow and Kazan structures. Creative tact, a high level of culture, and the esteem and harmony between the two authors--it can't be put any other way--defines the character of the interrelationship of these two buildings.

Other architects who are working on further developing the square have also valued this. The above ground pavilion of the metro that was built by D. Checulin which stands across from it is modest and the same time quite representative. The well-proportioned silhouette of the Leningradskaya Hotel recedes to the far end of the square; it was approached by L. Polyakov as a visual reference point that at the same time neutralizes the official

architecture of the Leningrad train station (architect K. Ton) that is of a different type than the ensemble. At the same time the sharp surface finish for the hotel counterbalances the train station's tower having closed the triangle of the square's high reference points. But the passage to Krasnoprudnuyu Street remains unincorporated: the low-story structures that formerly stood here seemed accidental and discredited the effect of the architectural completeness of the ensemble.

In order to eliminate this flaw a collective of Moscow architects was commissioned headed by A. Rochev who is the chief of the largest design organization, Mosproyekt-1. Together with L. Polyakov, he "became accustomed" to the architectural and spatial structure of Komsomol Square during the course of working out the plan, silhouette and details for the facades of the Leningradskaya Hotel 30 years ago. Now, under conditions of saturated activity at the largest transportation center and when the traditional concept of a square has been destroyed and its structure can be perceived only from the sidewalks, the scale of a new structure and the emotional nature of its architecture must take a special load upon itself. The fact that a pedestrian is deprived of "taking in" the square's whole ensemble when "exhausted" in the underground labyrinth of tunnels, suggested an approach to the architect of a lower structure on a large lot with 363,000 cubic meters of space.

As with other buildings, the department store can only be perceived in pieces. Therefore, it seems that it would be tempting not to be influenced by the distinguished neighbors in the selection of the materials and the details for the facades but to approach them as completely contemporary. However, the example that was achieved by A. Shchusev in relating to F. Shekhtel is convincing of the necessity of maintaining continuity in the elements of the square's ensemble that is taking shape....

To fill the "pocket" that was created behind the TsDKZh [Central Depot of the Kazan Railroad?] with a new structure, the authors of the design proposed an elongated form that has a serene silhouette and blended its primary mass into the depths of the lot having moved only a series of longitudinal sturdy show windows on the department store's low stylobate forward to the property line. A logical, confident passage from the square with its large space to the main thoroughfare was achieved with a different architectural and spatial rhythm. At the same time a new pedestrian square was formed near the store. Due to the blending of the basic form of the building with the rear portion of the lot--toward the railroad side--that is understated in relief, and with the functional subsidiary top sections that are moved in the same direction and covered with a broad belt of overhanging cornices for pedestrians, the department store building seems compact with a low extended shape. Only its modern outline makes it a little bit unique emphasizing the different non-train station nature of the building.

But the scale, the rhythm of the articulation and the theme of the arches joins it without difficulty to the links in the Shchusev complex and most of all to its neighbor--the TsDKZh building. The intentional theme of arches on its facade through the use of the decorative band is transformed and developed on all facades of the department store in a contemporary fashion. It is

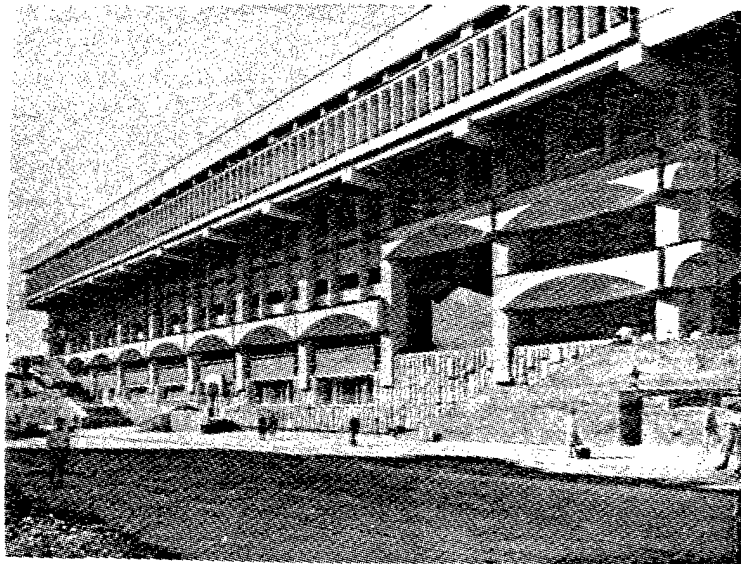
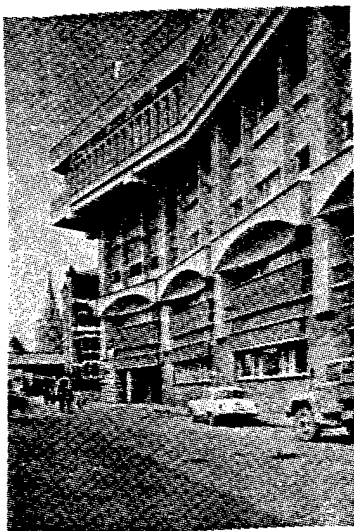
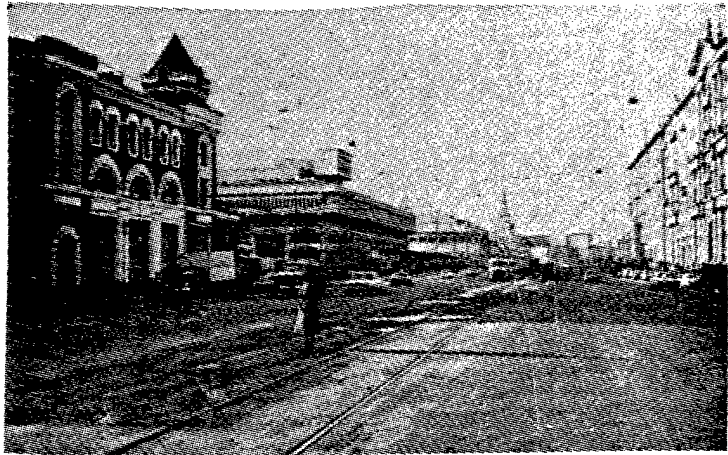

developed organically rather than formally since it is not purely decorative elements that were used as ornamentation but rather a functional facade panel in a lens-shape form. By joining the load-bearing columns it mimics the arch structure in commercial stalls that are traditional for Russian cities in a distinctive fashion.

The active use of a modern building material--arenite concrete--has also made it possible to represent on the facades of the department store the theme of the tower columns and teeth that are on the Kazan train station--the "embrasure" panels of the overhanging upper floor of the department store resemble them. These and other facade elements are made from precast reinforced concrete which offer a modern level of industrialized architecture and which have opened up extensive pliable potentials for concrete and made the use of finish materials unnecessary.

Much could have been said about the architectural, planning, aesthetic, and technological features of the new building that appropriately represents modern architecture alongside well-known architectural monuments. Not considering certain details the building on the whole fits in its place and forms all the foundations for talking about developing the square's architectural ensemble.

Upon leaving the light-colored interior of the store that speaks of the mastery and taste of the designers, your gaze again lingers on the square. You try to examine the separate forms once more and are annoyed that you cannot take in the entire ensemble in a glance. What if there were a well-planned square here (incidentally, this is one of the few squares that has no plants along its facades). And it would be appropriate and simply a required uniting element that a large monumental work should be put here which is dedicated to the heroic deeds of our komsomol. This would then be an architecturally, artistically and aesthetically complete square.... Instead of being "three train stations," as it is most often called, it would really turn into Komsomol Square and completely send out its patriotic call on a high level in the capital.

9495

CSO: 8344/1033

CONSTRUCTION PLANNING AND ECONOMICS

PLANS FOR SCHOOLS IN BULGARIA DETAILED

Moscow ARKHITEKTURA (PRILOZHENIYE K STROITELNAYA GAZETA) in Russian No. 25, 16  
Dec 84 p 7

[Article by R. Kyupribasheva, Bulgarian architect (especially for ARKHITEKTURA): "Schools in Our Day; the Architectural Environment for the Professional Training of Upperclassmen in Bulgaria"]

[Text] Five years ago, in 1979, the BKP TsK [Bulgarian Communist Party Central Committee] approved "Theses for Developing a System of Education in the People's Republic of Bulgaria" where a goal was set of qualitatively improving the professional training for students and creating a new type of Common Secondary Polytechnical School.

What should the new school buildings be for this and in what manner should the sector of professional training be organized? These questions trouble many architects. It is possible to judge how representatives of our creative shop are answering these questions by the experimental designs for schools.

A design for a school with 36 classrooms in Sofia is conceived as a compact composition that consists of three two-story buildings that are grouped around a three-story educational building. The interior courtyards are an extension of the school's hall and corridor recreation and are functionally isolated: they are for quiet games, for mass culture work and for recreation for the younger classes. Protected from the wind the open and semi-open spaces are suited for the specific climatic conditions of Bulgaria (the winter winds prevent children from going outside).

The general school center with an amphitheater and galleries reveals interesting vistas of the multi-functional space where meetings, concerts, demonstrations of movie films and also, possibly, contacts between groups are held. A library, cafeteria with snack bar, aesthetic disciplines and sports sectors are conveniently connected to the center.

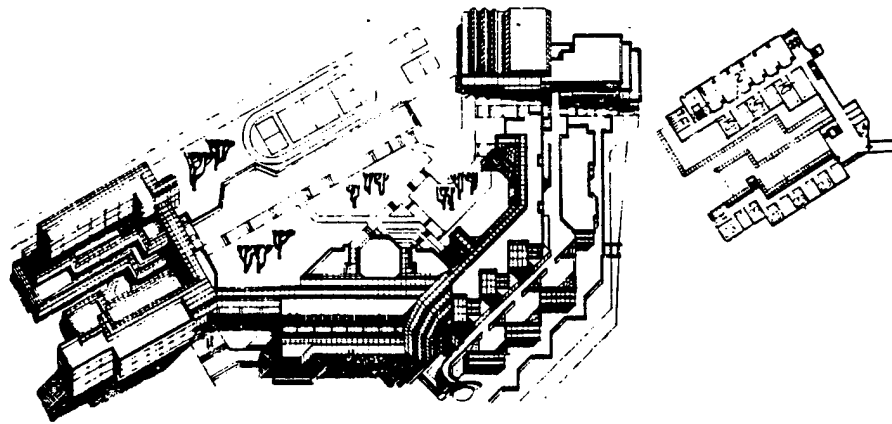

1

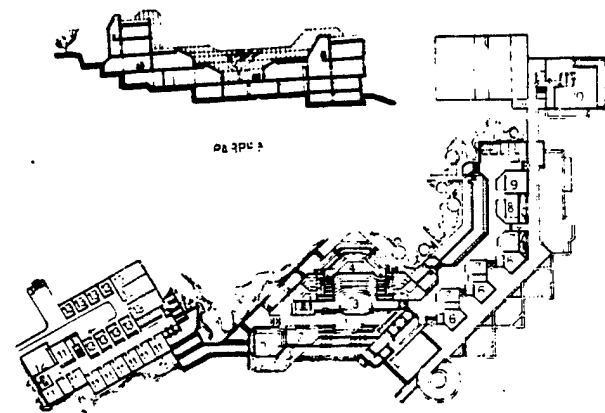

2

Diagrams 1 and 2. A school with 30 classrooms in Blagoyevgrad. Glavproyekt [Main Design Institute]. Architects I. Bitrakov and M. Petrova. Axonometric view, plan of the third floor, section and plan of the first floor.

When designing a school with 36 classrooms for the city of Slivnitsa the architects were presented with the difficult problem of reconstructing an existing school with 12 classrooms. A general school center with an amphitheater, library and cafeteria with a snack bar are joined to the old building. Bulgarian architects feel that the central spaces, which fulfill a communication role, play an important role in children's institutions. A sports sector with a physical education hall and swimming pool, a polytechnical training sector and a three-story building for the theoretical training of students in grades 5 to 10 is connected with it. The sector for young children is kept separate by means of a separate entrance and terraces. In this manner the age differences of all groups of students are considered. The orientation of the educational buildings to the east and south is conducive to creating a comfortable learning environment.

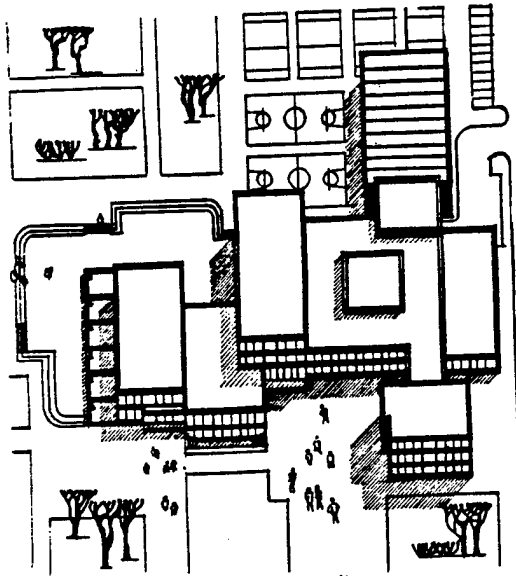

3

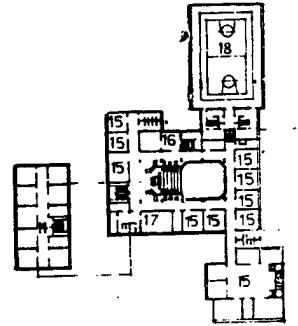

9

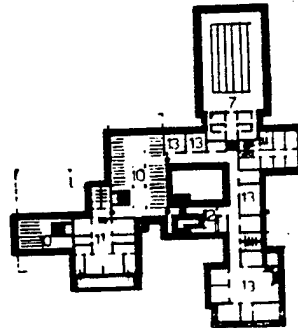
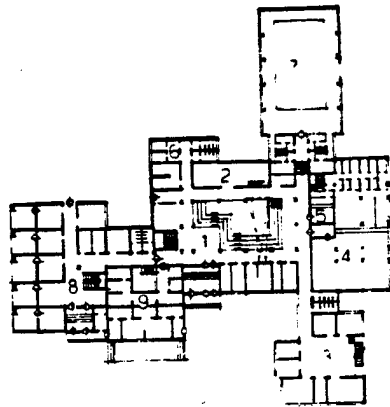

8

Diagrams 3, 8, 9. School for 36 classes in Slivnitsa. VIAS [Not further identified]

Architects I. Dragiyev, V. Ivanov, Ye. Moskova.

Axonomic view, plan of the first floor, plan of the second floor.

When designing the educational sector it was specified that the offices and laboratories for the theoretical training of upperclassmen and students in grades 5 through 10 be combined, which was stipulated by the same forms and methods of instruction. There are auditoriums for 70 and 100 people here, as well as offices and areas for group study. Recreation in a hall with a width of 7.2 meters is a new element where the independent preparation of students for their lessons is organized.

The school with 30 classes in the city of Blagoyevgrad is an example of a school building on sloping ground. In the opinion of the authors of the design the excessive drops in elevation and the complicated urban development situation dictated a volumetric spatial approach here. The lot has a triangular shape and is bounded by streets on three sides. Nonetheless the designers were able to create comfortable conditions for teaching all age groups as well as to form peaceful recreational courtyards and terraces.

Originally a general school center with an assembly hall was planned. Rehearsal halls, offices for aesthetic disciplines and an information center form the physical environment that is applicable for the aesthetic training of students and for their extracurricular activities. The central entrance vestibule, soaring stairs and galleries are lit by abundant overhead lighting and create a cozy atmosphere for contacts, mass culture work and relaxation. The open amphitheater seems to continue increasing the interior space in the assembly hall out into the air.

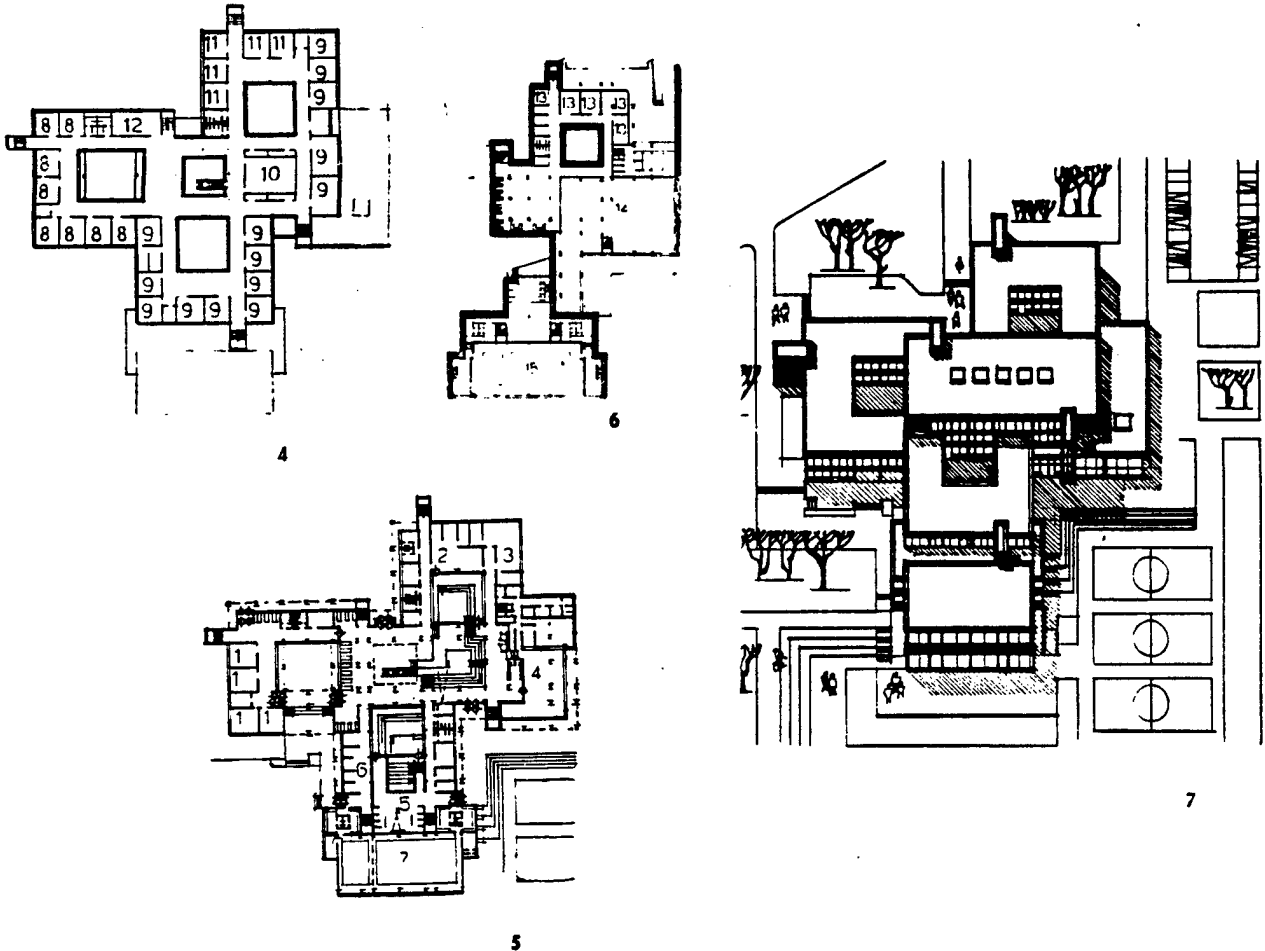

Diagrams 4-7. School for 36 classes in Sofia. VIAS Architects I. Dragiyev, N. Parpov and others.



The sector for the professional training of upperclassmen in machine building and the electrical industry is separated into a three- to four-story building with a complex configuration and an interior courtyard. All of the educational and professional education facilities are oriented to the southeast. By positioning this sector in the northwest direction of the lot the designers attempted to create a general class recreation zone that is protected from the wind.

What else has been obtained in this structure by the thoughtful use of the contours. The great change in elevation makes it possible to quickly evacuate students outside for the noon recess. Part of the flat roofs are used as terraces. The workshops on the first floor are very deep as a result of the use of the contour of the grounds. The contour is also boldly used for good access by transport means to the storehouse zone in the basement. A second entrance vestibule provides access for students from the upper level.

The complex contour of the lot forms a specific environment in which various functional zones have been organized through the use of the terraces: zones for the relaxation of the lower grades, for the relaxation of the upper grades, a sports zone and a zone for contacts between all age groups. The design specifies the possibility of the residents of the housing zone using the public sector, physical fitness hall and swimming pool.

The experimental schools will be built by the industrial method. A modular bay of 7.2 x 7.2 meters gives great flexibility in spatial planning approaches. The general school centers, assembly and sports halls and hall recreation areas will be covered by metal components.

The designs for the experimental schools illustrate two concepts of the architectural and spatial organization of the new type of secondary polytechnical school. In the first two schools the workshops for the vocational training of grades 4 through 10 are combined with the professional training workshops (grades 11 and 12) in the same manner as the educational offices and laboratories for the students in grades 5 through 12 in the theoretical training sector. In my opinion, in the future it is necessary to have a closer link between the facilities for the theoretical and practical training of upperclassmen as well as specifying facilities for scientific and technical work in designs.

The third example shows the possibilities of having a maximum age differentiation and of forming a secondary school from three relatively independent sectors: the lower grades, the age contingent including grades 5 through 10, and the sector for the professional training of upperclassmen. The public center and sports sector is common for all age groups. In the future it is possible to combine the sector for the lower grades with preschool institutions and eliminate this sector from the high school structure. In this way it will be possible to consolidate the school system as much as possible, improve professional training conditions and to build consolidated educational and professional complexes.

9495  
CSO: 8344/1033

CONSTRUCTION PLANNING AND ECONOMICS

PLENUM OF RSFSR UNION OF ARCHITECTS HELD

Moscow ARKHITEKTURA (PRILOZHENIYE K STROITELNAYA GAZETA) in Russian No. 25, 16  
Dec 84 p 8

[Article by Yu. Yevsikov, correspondent of ARKHITEKTURA (No Title)]

[Text] Novosibirsk--The 6th Plenum of the Board of the RSFSR Union of Architects was convened recently in Novosibirsk. Participants in it discussed the urgent problems of developing rural architecture in the republic. The successes of architects in Russia are quite significant in this field--since the beginning of the five-year plan more than 500 villages received diplomas from the USSR VDNKh [Exhibition of USSR National Economic Achievements] for architectural and planning approaches and model civic improvements that were successfully realized. Questions concerning further improving the quality of designs for farm-type and sectional housing units, industrial structures, reducing the cost of their construction and extensively using local materials were given special attention in the work of the plenum.

9495  
CSO: 8344/1033

CONSTRUCTION PLANNING AND ECONOMICS

NEW MAUSOLEUM ERECTED IN AZERBAIJAN

Moscow ARKHITEKTURA (PRILOZHENIYE K STROITELNAYA GAZETA) in Russian No. 25, 16  
Dec 84 p 8

[Article: "Monument to the Great Vagif"]

[Text] Shusha--As is known, construction art, no matter what utilitarian demands it may be meeting, is always directed to the future. But there is a field of architectural practice that turns to... the past. These are monuments, memorial ensembles and mausoleums that symbolize great events and victories; symbols that keep personalities alive in the memory of the people. One of these symbols for remembrance is the mausoleum of Vagif in the Azerbaijan city of Shusha. The authors of the project are architects A. Salamzade and E. Kanukov.

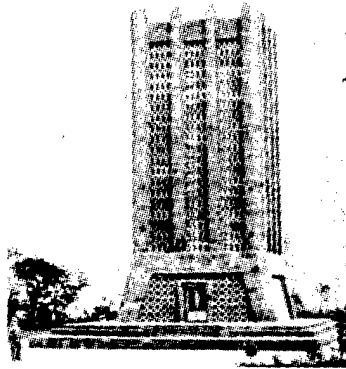

At first glance the mausoleum's architecture is approached from traditional principles for Azerbaijanian tower mausoleums. However, after careful study you will see that it possesses traits of our time in it. It is a square structure in plan view with a height of 20 meters that is erected from monolithic components and covered on the outside with marble that is a reddish tone which on the inside is light gray. In the center, over the grave of the poet, a sarcophagus made of light green Gadrut granite. A high relief of the poet has been put on the exterior wall of the hall on a stele that is the work of the sculptor A. Mustafayev. The entrance to the mausoleum was done in the form of an ornamental portal that faces the city. The mausoleum closes the vista of the main avenue.

For the first time in structures of this type the authors declined to divide the interior space into tiers which is traditional and somewhat archaic. Here the interior is perceived as being a uniform whole which is conceived as a funeral hall that is open for visitation. The authors also declined to have a cupola which is traditional for Azerbaijanian mausoleums. The vertical columns in combination with decorative fillers create an impression of upward flight, lightness and the national coloring.

The extreme clarity of the architectural and artistic project, the logical nature of the composition, and the harmony of the structural and artistic approach to the monumental and decorative plastic arts--this is the effect of the form of the mausoleum for the great Azerbaijanian poet Vagif Moll Panakh.

9495

CSO: 8344/1033

CONSTRUCTION PLANNING AND ECONOMICS

1984 ARCHITECTURAL LAUREATES LISTED

Moscow ARKHITEKTURA (PRILOZHENIYE K STROITELNAYA GAZETA) in Russian No. 25, 16  
Dec 84 p 1

[Article: "1984 Laureates"]

[Text] Half of the materials in the last issue of ARKHITEKTURA were devoted to the III All-Union Review of the best construction projects of the year that was recently conducted by the USSR Union of Architects. Readers are already familiar with a portion of the projects and the last names of the majority of the author laureates were mentioned. Today we are publishing the remaining names. The following were awarded the USSR Union of Architects' Medal: architects A. Anisimov, Yu. Gnedovskiy and B. Tarantsev, co-author of the second phase A. Kuvshinnikov, engineers V. Belitskiy, I. Gerasimov and R. Murashkin, and with the participation of architects T. Beloborodko, V. Kulikovo, N. Orlov, O. Shmidt and S. Gnedovsk and N. Dupak on the technology who received the award for the theater for the Moscow Drama and Comedy Theater in the Round project; a diploma was conferred on architects L. Popov, V. Volovich, and G. Mun, artist A. Moseychuk, and structural designer T. Protserova for the design of the "Nakhimovskiy Prospect" subway station; and the following were given a special diploma: architects A. Nezhurin, and Yu. Chubarov, authors of individual buildings K. Nazarov, V. Petrenko, L. Serova, L. Kokhanova, and S. Lopatin, and engineers I. Tomshinskaya, Yu. Golovin and V. Bushuyev for the design of the "Oshskiy Bazar" market in the city of Frunze, architects V. Filimonov for the design of the Khakim-i-Termezi architectural complex in the city of Termez; architects S. Shteyrin, M. Guseva, V. Krasnov, M. Torkova, and K. Alekseyev, engineers L. Kiseleva, V. Semenov, A. Fradkov, A. Bizyayeva, and G. Andreyeva and artist Yu. Belibin for the design of the Reinforcing Plant imeni Lapse in Leningrad.

In the future the editorial board intends to discuss every project that was mentioned in the review and give analytical materials that would acquaint readers not only with the architectural approach but also with the professional credo of the authors.

9495  
CSO: 8344/1033

CONSTRUCTION PLANNING AND ECONOMICS

TAJIK ARCHITECTS' CONFERENCE HELD

Moscow ARKHITEKTURA (PRILOZHENIYE K STROITELNAYA GAZETA) in Russian No. 25, 16  
Dec 84 p 1

[Article: "Tajik Architects Conference"]

[Text] Dushanbe--Just several decades ago there was no such concept as "architecture" in Tadzhikistan. Yet recently architects from Dushanbe, Leninabad, Nurek and other cities, rayons and villages in Tajik SSR gathered for the 13th conference.

The architects were greeted by the Secretary of the Tajik Communist Party, T. Mirkhalikov. Deputy Chairman of the republic's Council of Ministers R. Gafurov, a delegation from the USSR Union of Architects headed by Secretary of the Board Yu. Gnedovskiy, and representatives of the architectural community of Moscow, Leningrad and other cities took part in the work of the conference.

Dushanbe is a fine city. Its greenery, the classical color of its buildings, and their conformity to human scale pleases the eye. And this uncommon method of urban development and architecture began to be developed just 40 to 50 years ago.

After a lively discussion of the results and long-range outlook for the work of the Tadzhikistan SA [Union of Architects] new board membership was selected. It was made up of Chief Architect for Dushanbe R. Karimov (chairman), well-known architects in the republic such as E. Salikhov, Yu. Parkhov, E. Yertzovskiy, Sh. Karimov and others--fourteen people in all.

9495  
CSO: 8344/1033

CONSTRUCTION PLANNING AND ECONOMICS

RECONSTRUCTION AND RESTORATION OF OLD VILLAGES

Moscow ARKHITEKTURA (PRILOZHENIYE K STROITELNAYA GAZETA) in Russian No. 25, 16  
Dec 84 p 1

[Caption for sketch on page 1]

[Text] The restoration and reconstruction of rural architectural monuments is one of the most important problems for modern architecture. Students in the Moscow Architectural Institute led by A. Shishkov, who is an instructor at MARKHI [the Moscow Architectural Institute] and the leader of historical and architectural expeditions for the Central Council of VOOPK [not further identified] have been investigating the territory of Arkhangelsk and Vologda Oblasts and the Komi ASSR for more than 10 years. Their work was not limited to uncovering previously unknown folk architectural and cultural monuments. A new concept was introduced into scientific practice: any village is a natural architectural complex.

The picture shows a design for the reconstruction of the Ruchevo village in Arkhangelsk Oblast. You can read about this development and about the problems in designing northern villages in one of the future issues.

9495  
CSO: 8344/1033

CONSTRUCTION PLANNING AND ECONOMICS

ROLE OF ART AND ARCHITECTURE IN URBAN PLANNING

Moscow ARKHITECTURA (PRILOZHENIYE K STROITELNAYA GAZETA) in Russian No. 25, 16 Dec 84 p 1

[Article by A. Amirkhanyan: "A Person Needs to Come in Contact With Art More Than Just in Museums and at Exhibits; Afterword to the All-Union Conference Devoted to the Theme of An Overall Formation of the Architectural and Artistic Environment of the Cities That Has Been Done By the USSR SA [Union of Architects] and USSR S<sub>kh</sub>[Union of Artists]"]

[Text] Korbyuze said "A city is a powerful image that increases the activity of our mind. Why could it not become a source of poetry?" Incidentally, it has been such a source until recent decades which is evident in, well, at the very least the urban romances of our contemporary B. Okudzhava. But in all the poetry you will not find a single line about the new housing and bedroom rayons that are the conveyor products of our designers and housing construction workers. How can we maintain the industrial rate of construction and at the same time humanize these rayons and make them more the authentic works of art of architects?

The word "environment" itself in the name of the conference says much. For it, the housing environment, is the final product of the activity of builders and not at all just square meters of new apartments. In the press they now often mention new rayons that are built in an overall fashion (one of these is Krylatskoye in Moscow), and the State Committee for Civil Construction and Architecture rebukes journalists regarding this: you say that this should also be practiced in other cities. What are you saying... Information for such publications must be collected not only at the construction site and at the design institute. For if one of our writer friends came to, let's say, the Housing Committee Administration or the Administration for Planning and Building Cities he would immediately write down in his notebook that the State Committee for Civil Construction and Architecture worked out their position concerning the urban development complex two years ago and have been intensively instilling it in the consciousness of those who are associated with the development of cities. And these are the local authorities and construction ministries who have under their jurisdiction the housing construction combines and other construction organizations.

In addition the workers on the committee have included a much larger concept than just the rayon in their understanding of the "urban development complex"



where the service sphere and children's, medical and other institutions are being erected at the same time as the housing. What exactly is this concept? Go to the city of Minsk and walk along its "green diameter" and you will understand what it is. For the State Committee for Civil Construction and Architecture and the USSR Union of Architects do not tire of propagandizing such an environment as being one of the best models.

However, I guess a word by the participants in the conference should be given.

Ye. Rozanov (architectural academician). Today cities in different typological groups are appearing that require an individual approach to development. "Spatial hypertrophy," which is manifest almost everywhere, needs to be eliminated. What, then, is obtained? In pursuit of compactness for development we lose the quality of this project.

The work of artists must be planned. Through our combined efforts we propose to work out specific recommendations for humanizing the environment of cities. The work of artists should be taken into consideration right when the tasks are assigned to the designers. In this regard I consider it necessary to make changes even to our position on the urban development complex.

A. Gutnov (professor at MArkhI [Moscow Architectural Institute] and Doctor of Architecture). We are not just interested in the structures themselves but also in the space that they form--the urban environment as a whole. A monumental sculpture as a monument in squares. A monumental painting in interiors and very rarely on the facades of buildings. Decorative design art in parks and sometimes in housing blocks. That is all, perhaps. The synthesis of fine art and architecture almost always neglects whole urban worlds--industrial enterprises, transportation, massive service structures, etc. We are compelled to state that in many cities art exists by itself, not forming urban space but only using it as an exposition. It does not become a part of the city and urban culture. In order to achieve progress a clear conception of the artistic organization of space is needed.

L. Sokolov (Senior scientist at the TsNIIP [Central Scientific Research Institute for Design] of Urban Development). Putting cubic meters of capacity in structures into use is often substituted for a solution to aesthetic problems without carefully including amenities and artistically shaping the environment. A legally approved interrelationship between the architect and artist is lacking during the design of the city. In addition, the existing design system does not specify how aesthetic urban development questions are to be solved either in the organizational structure or in the financing system. The development of an artistic conception for the environment should begin at the general plan stage. In cities where an old environment is alive we come in contact with a scale that promotes the origin of positive emotional contacts among people. In new cities we are gradually losing the roots of the environment. The future is for the complex integration of structures that are created by the collaboration of artists and architects.

You will notice that in this discussion the theme arises of urban environments in old cities and the construction of new rayons that have lost many of the

parameters of their historical environment. Since we have already spoken about the loss of roots we will turn to the question of who could have "balanced" the old and the new situations. But first we would note that the coloring scheme that was implemented by the architect L. Sokolov and his colleagues when building the northern planned rayon in Yaroslavl is one of the successful examples of harmony between the old and new. Henceforth, both the center of the city and the new rayons will have their own unique coloring based on the traditions that have been revealed and embodied. However, the question is not just about solving coloring problems but of a global approach to the matter of preserving the old environment with the emergence of new development. One of the authors of the design to restore old Tbilisi, architect G. Batiashvili, who gave an interesting report on the problems of regenerating the old environment, shared his views exhaustively and specifically.

G. Batiashvili (Secretary of the Board of the Georgian SSR Union of Architects). First of all one must interpret the specific environment that was formed that gave it this or that quality. Keeping in mind the humanization of a new structure through industrial methods the key should be sought to create a new environment from it. In the center of Tbilisi a person feels perfectly like a valuable part of the environment.

A fundamentally new task stands before us. Where before we solved the problems of preserving the old in the new now a unique inversion is taking place: in rayons where there is new development we attempt to adopt in our urban architecture all that is valuable and all the richness that has accumulated over the centuries. And we give a large role to architectural and artistic synthesis in this productive process; in particular we are for design in architecture for it aesthetically and functionally equips practical urban space. We are trying to test our concepts in the designs for the "Narekala" and "Verkhnyaya Kharpukhi" slopes. As before regenerative work is going on in close contact with the gorispolkom. This helps us to effectively solve difficult questions including financial ones.

S. Valerius (Secretary of the MOSKh [not further identified] and chairman of the committee for the synthesis of art and architecture). The point being made concerns the problem of instilling our art into the living environment that surrounds a person everyday. One of the achievements of maturing socialism must be understood and interpreted: a person is not satisfied with meeting art just in museums and at exhibits. In a specific environment its functional purpose, which to a large degree is determined by spiritual needs, must be determined by the character of the art, its types and genres, which in synthesis with architecture and urban development will create an atmosphere of inspiration.

9495  
CSO: 8344/1033

CONSTRUCTION PLANNING AND ECONOMICS

ARCHITECT ASSESSES NEED FOR VISION IN PLANNING

Moscow ARKHITEKTURA (PRILOZHENIYE K STROITELNAYA GAZETA) in Russian No. 25, 16  
Dec 84 p 2

[Article by A. Isayev, architect: "How Much Does An Unimaginative Thought Cost?"]

[Text] Cheboksary--When designing everything to be the most useful, durable and beautiful the architect hopes to see that which he has conceived in reality. The meaning and stimulus of his work is contained in this, yet how often does the meaning get lost and the stimulus disappear (and sometimes is lacking entirely) when a crippled model or something entirely different emerges from the fragments of ideas and emotions about which he had not thought or guessed.

You will hear a lot of talk in explanation of this phenomenon which is embodied in the ancient but urgent problem of "the design and its realization." Some cite the carelessness of builders and the lack of materials that are required, others the organizational deficiencies in design and construction affairs, and a third party the strong-willed interference by management agencies, etc. Each point of view, without a doubt, is not devoid of validity; however, the uniform feeling among the majority of those that come forward and blame the conditions of life strikes one plainly as they see in them the reason for all their troubles and disappointments. But few remember whether or not we put the most useful, durable and beautiful things in our designs and whether or not we approve and forecast correctly.

Certainly it is much more difficult to admit our own mistakes than to brush everything aside due to circumstances yet, obviously, this must be done since the chief aspect of the problem of realizing design proposals, and the effectiveness of our work depends on the successful resolution of this problem, should become not the organizational, economic, technological, etc. difficulties but precisely those professional difficulties that are concealed in the method and methodology of design work since designers work according to their rules while life develops according to its own.

Actually, the point concerns the two processes of one general matter that should be joined together and which are not joined together. The discrepancies between the processes of designing and implementation lead not

only to a loss of effectiveness of the design approaches but also to more substantial losses that are expressed in expenditures for useless design work, to recover losses due to decisions that are not thought out and for incorrect forecasts which are associated with a multitude of specific approaches at various stages of design work and the magnitude and value of the expenditures for that which is thought out and implemented increases to the degree that the levels of design work increase.

When depicting small forms (based on specific orders) we have a right to hope that they will be completely implemented without any distortions. This happens very often and there are practically no distortions yet when there are who will this affect and what will it cost?

Certain buildings and complexes are already disturbing. The possibility of distortions and, consequently, also of social and economic losses arises but who will calculate them? A person accepts all of our miscalculations as he should, as the finger of fate, heroically battling with their consequences his entire life (housing) or simply does not notice (industry); at first he swears, then accepts it and good naturedly jokes about it.

But when matters reach the level of a microrayon, city or agglomeration (urban development and regional planning questions), it is no longer a joke. Our inability to manage the urban development processes through planning means and the weakness (and sometimes total lack) of creative conceptions lead to a city dweller having to spend a third of his life moving about in overcrowded public transportation experiencing the whole weight of the peak loads and breathing in the "aroma" of industrial smokestacks and exhaust gases from motor vehicles while continually feeling nostalgic about the smell of the forest and the singing of birds at the same time that a resident of the village, having plenty of all this, is striving to go to the city hindered by the lack of roads, the length of the distances and the poor transportation network. Who will answer what and how much this all costs?

How much does it cost to thoughtlessly locate a heavy industrial enterprise that "eats up" everything around it and cuts off the sole route of expansion for cities? Cheboksary and Novocheboksarsk can serve as a good example of this. How much do the inefficient transportation and utility lines cost that loop around and through the city (not to mention the poor quality)?

Many similar questions can be asked and no answer received. Overall what are we generally talking about if a design is not implemented or is implemented in a different way than was thought or if so many designs are turned out for the same rayon (the design project) that they can be put aside for a year for this reason yet the project does not improve because of this.

Such a situation can be observed, for example, in those regions where large hydroelectric stations were built, the construction of which served not only as the first impulse to develop the vast territories but also as a stimulus for further concentrating industrial production here and at times (depending on the degree of favorable circumstances) very large ones. The rayons near the construction of the large GES [hydroelectric stations] on the Volga-Kamsk

cascade can serve as characteristic examples where the largest machine building complexes for producing motor vehicles, tractors, etc. were located here after the hydrocenter, and sometimes at the same time.

A large number of designs were the result of repeated revisions to design approaches. For example, the Lengiprogor Institute [Leningrad State Institute for Urban Design] issued 13 urban development designs from 1958 through 1980 (schemes and designs for regional planning, designs for the zones surrounding the city, and general plans for the cities near the GES) that affected the zone influenced by the Cheboksary GES, i.e., the design process went on practically nonstop. Approximately the same thing can also be observed in other regions where construction of large GESs on the Volga-Kamsk cascade is on-going.

The general plans for new cities (with the villages for the hydroelectric construction workers as a base) and cities that are located in the immediate vicinity of the GES are revised especially often. For example, six designs for urban planning were worked out for Tolyatti (Kuybyshev Oblast) since 1951 (the beginning of construction of the GES imeni V. I. Lenin): by Lengiprogor (for 40,000 people), then by the Kuybyshev Oblast Design Institute (for 80,000 people), somewhat later by the Kuybyshev Oblast Design Institute (for 80,000 people), somewhat later the Kuybyshev Hydraulic Construction Design Institute (for 120,000 people) and again by Lengiprogor (for 330,000 people). In 1966 the necessity arose of building a new section of Tolyatti (Novyy gorod) due to locating the Volga Motor Vehicle Complex here. At first the TsNIIP [Central Scientific Research Institute for Design] of Urban Development proposed an estimated number of urban inhabitants at 500,000 people and then (in 1974) at 750,000.

Certainly, the example of Tolyatti can be placed among the ranks of special ones, but this is not an exception to the rule but rather a clear confirmation of it. The majority of cities near a GES were developed and are being developed intensively and the development occurs more intensively as the totality of favorable conditions is greater. The examples of the regions where large GESs were built graphically demonstrates what results from a pattern of thought and from threading traditional methods and examples into a non-traditional design project.

Today what is needed is not blind research into continuously changing conditions and applying the next design to it, but rather scientifically-based foresight (forecasting) for a long-range planning situation by taking into consideration the development features of the specific territories and developing models for their overall implementation and development in stages. In a word, the object of the design work must be understood as a difficult child must be understood and the "key" to it must be found--imagine the object as a process that grows in time and space. Such an approach can become a guarantee of the reliability and stability of the design approaches; it requires a search for regularities in development, new non-traditional design methods and new creative concepts. Only then can we expect a design and its realization to be as close as possible and that expenses and losses be kept to a minimum.

It is expedient to conduct similar scientific research everywhere and most of all in places where it is necessary to develop specialized scientific centers that know the specific nature of their region the best (oblast, kray, autonomous republic), yet they are far from being everywhere. These centers could control the appropriate scientific groups, so called predesign analysis groups in local design institutes. Such groups, unfortunately, are very rare yet they could become the primary local science center and at the same time be the "disturber of the peace" which many "sleepy" urban design institutes obviously do not possess. There are personnel in every institute for this and they only need to be "discovered" and given the opportunity to work.

Using the concept of "infrastructure" that is now in vogue in science, it can be said that society needs our profession to develop a scientific infrastructure with a complete collection of all its component parts--a single motive mechanism for progress. Regional planning is especially needed in such a mechanism which itself is already partially scientific work and for which the realization of the design approaches is the most important indicator of its effectiveness. However, regional planning ends where it begins: in the not very numerous central scientific and research and design institutes. Coming out of their walls it hangs like a gray cloud in these places stretching into a question mark due to the surprise at the lack of understanding and clumsy treatment of it.

Specialists in regional planning have repeatedly indicated the need to form special groups (sectors) for regional planning on location as a part of administrations for construction and architectural matters and special interdepartmental commissions for implementing regional planning whose obligations would consist of supervising, controlling and establishing changes and violations, making corrections, etc.; but up to now practically everything remains as before.

Matters will not change if the problem of training specialists in regional planning is not solved. To achieve this, special courses at central institutes and something similar in the way of a year's course for the faculty to increase their qualifications is needed (not to mention college education), one of the main goals of which would be the formation of a connecting link in the chain of a single design and construction conveyor, a kind of flow line "design to implementation" where each section fulfills its operation yet all together complete one general task.

9495  
CSO: 8344/1033

CONSTRUCTION PLANNING AND ECONOMICS

NEW DESIGNS REVIEWED

Moscow ARKHITEKTURA (PRILOZHENIYE K STROITELNAYA GAZETA) in Russian No. 25, 16  
Dec 84 p 2

[Article: "New Designs"]

Alma-Ata's Green Diameter

[Text] Alma-Ata--The desire to relax near water during the hot season is natural. For a city like Alma-Ata this becomes a necessity. Because of this necessity and in accordance with the general plan for Alma-Ata a recreation zone is being located along the Bolshoy Alma-Ata canal line that intersects the city. The authors of the design, a group of specialists from the GPI [urban design institute] in the Alma-Ata Giprogor [state institute for urban design], conceived it as an integral part of the whole urban development system. Foot paths will lead here from adjoining housing rayons. The natural banks of a picturesque pond, the floodlands of the Malaya Almaatinka, a large forest-park tract--every nature area is also included in the recreation area. A characteristic feature of the design is that stylistic unity distinguishes the architectural approaches to the small forms and service structures. Durable building materials are used for the finish work that preserves the high architectural quality of the surface: coquina from the Mangyshlak deposits and real stone.

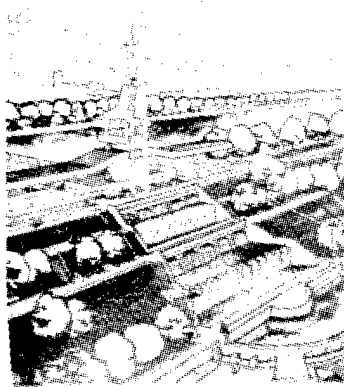

### The Advantages of a Monolith

[Text] Yerevan--Two-apartment, two-story, four- and five- room farm-type housing units. This work can be described in one word--an experiment. In order to gain some expertise in developing one of the streets in experimental model sovkhos number four in the Ararat rayon specialists from ArmNISA [not further identified] (architects F. Asatryan and B. Matevosyan, technologist for the erection R. Mkhikyan, and structural engineer G. Shogeryan) decided to test spatial planning and structural approaches for new types of housing units that are built from monolithic concrete and to try out three-dimensionally adjustable forms from the point of view of the expediency of adopting it in mass-scale low-story housing construction. The design demonstrates such advantages of monolithic concrete as the possibility of compositional variety, the seismic stability of the structure and a reduction in the duration of construction. Preliminary calculations have shown that the cost of one square meter of housing in the given case was 20 percent lower than in large-panel housing units.

The apartments are "open" to the recreation zone and conveniently connected to the farm structures and lots.

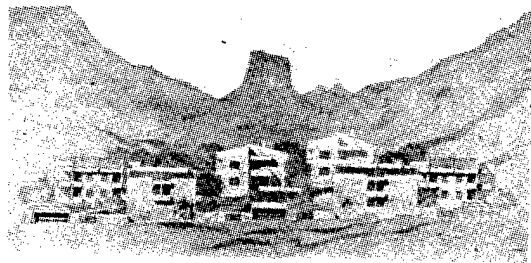

A Portion of the Development of the Street in the Experimental Model Sovkhos.



### Along the Road to Lasnamyae

[Text] Tallinn--Reconstruction is one of the most curious areas of architectural activity. First of all because it is accompanied by the recognition of the architect's participation in the creation of the previous author. Secondly, because by either continuing the architectural intentions of his predecessor, or just the opposite, by refuting them the architect deliberately makes the thing unique and displays himself.

All of this fully pertains to the work presented in the photograph--a semifunctional company house for the "Khiyu Kalur" kolkhoz. This building is being built in Tallinn on Pae Street based on a design by the architect A. Alver where an existing building is located and, by the way, it is a very plain looking house. According to the design only the exterior walls are being preserved. The lot is used very efficiently: in locating the attached garage structures the architect created an intimate interior courtyard. The courtyard side of the building was developed through the use of "multilayer" architecture. Yet the exterior north facade which faces the street side that leads to the Lasnamyae microrayon looks more stern. All four floors of the building are pierced vertically by a light "well."

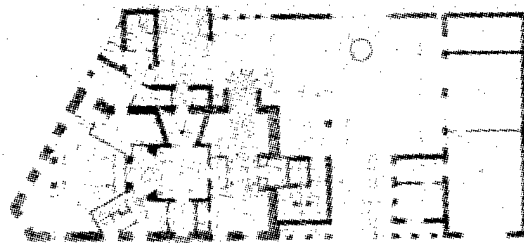
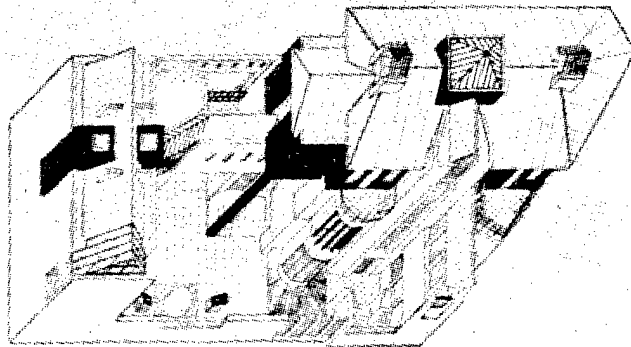

9495  
CSO: 8344/1033

CONSTRUCTION PLANNING AND ECONOMICS

ARCHITECTURAL APPROACHES TO INDUSTRIAL STRUCTURES

Moscow ARKHITEKTURA (PRILozHENIYE K STROITELNAYA GAZETA) in Russian No. 25, 16 Dec 84 p 3

[Article by L. Viktorova, candidate of architecture: "The Architect and the Plant; What an Architect Can Give to an Industrial Structure"]

[Text] In many instances our industrial enterprises present themselves as paradoxical compositions of monotony and chaos. The production buildings appear monotonous and the engineering structures and small buildings for subsidiary purposes appear chaotic. This can be explained by the spatial planning features of the former and by the large quantity and also diverse character of the latter form. Each engineering structure or building is built according to its own typical design and with its own components, curtainwall and details. To the point, typical designs for industrial enterprises, buildings and structures now number 14,000....

Overall uniformity of the site--the basis for architectural unity--is still being accomplished only at large unique plants such as the VAZ [Volga Motor Vehicle Plant] or the KamAZ [Kamsk Motor Vehicle Plant]. It is considered as requiring too much labor for massive construction; it is felt that each design must be worked out in the finest detail in order to achieve overall uniformity of the site. But this is not so. The TsNIIPSK [The Central Scientific Research Institute for the Design of Structural Components] has proposed a solution to this problem where a series of typical designs for steel reservoirs for aggressive chemical products has been developed. The exterior enclosure components and stairs that serve the sites and other small elements as well as the measures to protect against corrosion are not specified but rather it is suggested that they be determined when applied to a specific project.

The traditional practice of developing individual typical designs for each small structure is in contradiction with modern demands for an overall approach to forming a construction project. It is expedient to design engineering structures and the subsidiary buildings that are associated with them in an overall fashion. For example, the water tower should be designed together with the pumping structure. Only under these circumstances can one hope that they will be built in the same style.

In this regard practice gives approved examples. The designs for biological purification stations were done in an overall fashion in particular for BAM [Baykal-Amur Mainline] and each of them includes up to twenty structures that were able to be designed in a modular fashion. All of the small buildings were joined to the whole and onto which a section of various settling tanks was built. Only the ponds for the extracted materials were located individually.

It is desirable that structures that make up a complex are worked out in one design system. In many cases this recommendation is not observed. For example, a base located near railroad tracks for mineral fertilizers, lime materials and pesticides (worked out by the Industrial Transportation Design Institute) is a complex of 20 structures of which 10 are buildings. All of them were done from typical designs. Understandably, there is no architectural unity at this base. What then was the sense in separate designs for the structures? Maybe for an improved layout? This is not so--the configuration is cut up and the structures are not in a unit; the form for the site is in one variation.

For a long time it was felt that engineering structures are not a subject for architecture. This is, certainly, not true; however, one stipulation should be made: in many cases structures that are designed to be functionally correct acquire perfect form even without the participation of an architect. This is supported by an analysis that was done by TsNII [Central Scientific Research Institute] for Industrial Buildings between 1980 and 1982. We recall what a powerful visual impression the hyperbolic forms of the cooling towers, the high-tension electric transmission towers, the metal exhaust towers, etc. make.

The object of attention for architects should be, first of all, the various structures that are added on and built on--they usually bring chaos and disharmony to the shapes of the structure. Their forms, as a rule, are not adapted to the technical forms; a special series of window and door openings and other architectural elements has not been developed, for example, that is coordinated with the technical forms of the engineering structures themselves. This work can only be placed on the shoulders of specialists in the creative professions--architects and designers.

The appearance of a construction project for industrial enterprises is in many ways also formed by the linear engineering structures--the numerous galleries, gantries and pipelines that are designed according to typical series. They join the disconnected construction project and at the same time divide it. Their weak point, from the architectural point of view, is the insufficient uniformity of the components.

What happens if a gantry, various pipelines and galleries are located on a single support! It would be better that this structure had a complicated structural shape for this would then present greater possibilities for organizing the space not to even mention the savings in territory and materials. Such a communications gantry-gallery has been designed at KamAZ for laying the primary heat, gas and water mains and the conveyors and

pneumatic transports together. In certain places it is combined with a technological engineering gallery and a motor vehicle transport gantry. So many diverse components in one unit! Transport and pedestrian galleries could go into it. But, alas, standardized columns for single-story buildings or even piles are usually used as the support under the utilities, that is, structures for a completely different purpose.

It is now time, here, to remember those cases where a structure has been designed somewhat "correctly," or more accurately, in accordance with existing canons--yet from the point of view of aesthetics it cannot withstand criticism. This happens when the structure has not been revised in its structural or technological approach for a long time; in such a case it longs for an architect.

Take, for example, water towers. Their tanks can come in any shape--either particularly utilitarian or biased toward the decorative end. A water tower was built in the shape of a coffee pot in one small city in France in a forest park zone. This, certainly, is overdoing things in the name of humor. But there are water towers that, without any exaggeration, adorn both industrial complexes and housing villages. We have not improved on structures of this type for a long time and, therefore, their designs have become morally outdated and are devoid of any aesthetic merits.

It is appropriate to remember in connection with this that it is advantageous to make improvements to components (in those cases where it was time to begin them long ago) with the participation of an architect. It is he, and no one else, who can consider the architectural requirements. Chief among them are that the form of the structure should reflect the work of the components and materials.

Let us return to the example of using standardized columns or piles for the engineering structures. The principle of adapting standardized components for buildings for this purpose (that a short time ago was considered progressive) should yield to a more modern principle--the economy of materials. For example, columns for one-story buildings and piles are used for gantry pipeline supports. The column can bear a large load yet on top of it are pipes that are not very large in cross section. Or take the supports for spherical gas tanks. It is as if they are stuck into the sphere and connected together by a pair of rigid cross pieces and look, therefore, not like supports, but like brackets. It would be more architecturally correct to make the gas tank with a support ring and replace the rigid elements. The shafts of water towers are also not aesthetic and are almost equal to the width of the tank in cross section. Their components more closely express weakness and not power.

No, you cannot treat engineering structures as second-class structures that are best camouflaged. They themselves can become a decoration for enterprises and the landscape. The architecture for industrial enterprises acquires certain features that illustrate the formation of the particular technical surroundings. The style of the construction project changes and acquires a technical character due to an increase in the number of uncovered utility

lines, installations and units. Under these conditions the engineering structures are objects that possess both technical and architectural details and become the linking elements between the architecture of the buildings and the technical forms of the open equipment and in many ways determine the style of the construction for the industrial enterprise. Therefore, I think, the positive experiences of the Moscow, Irkutsk, and Siberian Industrial Construction Design Institutes should be extensively disseminated.

The following are typical approaches to engineering structures:

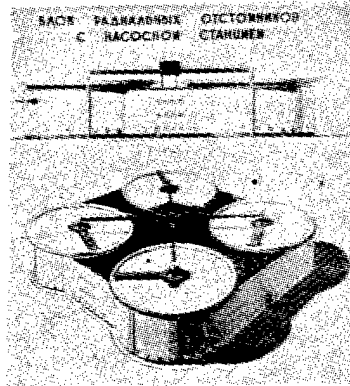

Pump Sediment Unit (developed by the Siberian Industrial Construction Design Institute )

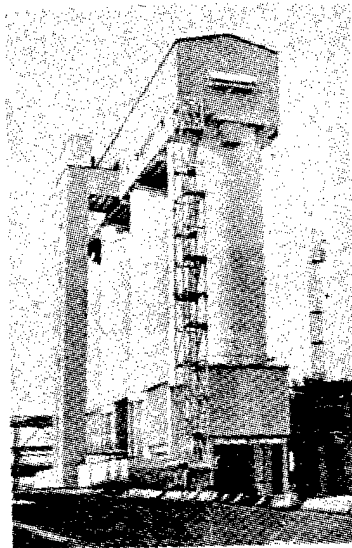

Silo Towers for an Alumina Storehouse (By the Leningrad Industrial Construction Design Institute)



**A Small-Scale Saltworks on the Roof of a Building (By State  
Institute for the Design of Machine Tools)**

9495  
CSO: 8344/1033

CONSTRUCTION PLANNING AND ECONOMICS

CONTEST HELD TO DESIGN VILLAGE

Moscow ARKHITEKTURA (PRILOZHENIYE K STROITELNAYA GAZETA) in Russian No. 25, 16  
Dec 84 p 3

[Article by I. Eltman: "Contests; Raskayetsi: A Look into the Future"]

[Text] Moldavian SSR—A fine tradition has recently emerged in Moldavia--announce the design of the most important projects beforehand through architectural contests which make it possible to enlist young specialists in the creative work side by side with the leading architects. Rural subjects occupy a significant place in these creative contests. One of the recent contests, which was conducted by the MSSR [Moldavian SSR] Gosstroy, the MSSR Council of Kolkhozes and the republic's Union of Architects, was related to the Novyye Raskayetsi village in Surovsk Rayon.

The participants in the contest were given the assignment of working out design proposals whose realization would make it possible to accomplish the fundamental reconstruction of the village in stages while preserving the high quality of the housing supply as much as possible, to modernize it, and to introduce more modern types of one- and two-story farm-type housing units. The second part of the contest terms specified the formation of a public center for the village.

The design that received first prize was done by a team that was headed by rayon architect V. Revenko. The work organically combines urgent, long-range, utilitarian, architectural and artistic goals. At the same time particular attention was given to the proportionality of the scale of the main square and the structures that form the construction project and the convenient link to the extensive recreation zone and sports complex. In the photographs are portions of the design that received first prize (top, next page) and second prize (below, next page) by V. Ilin's team from the Moldavian Civil and Rural Construction Design Institute.

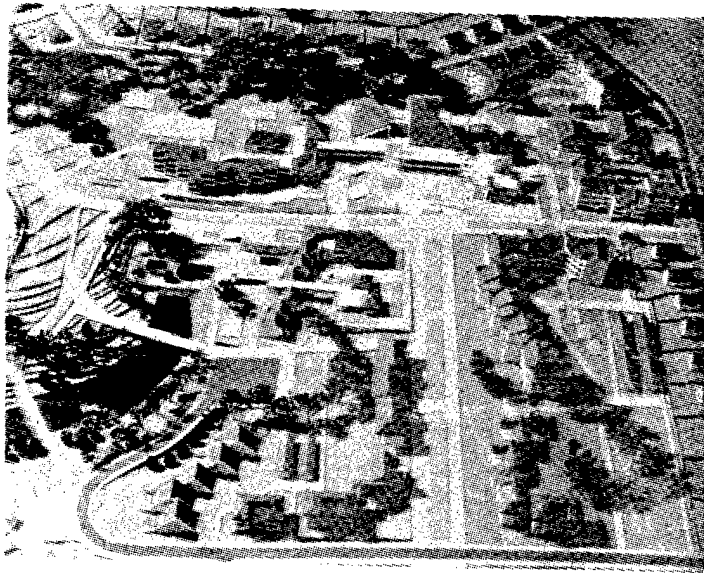
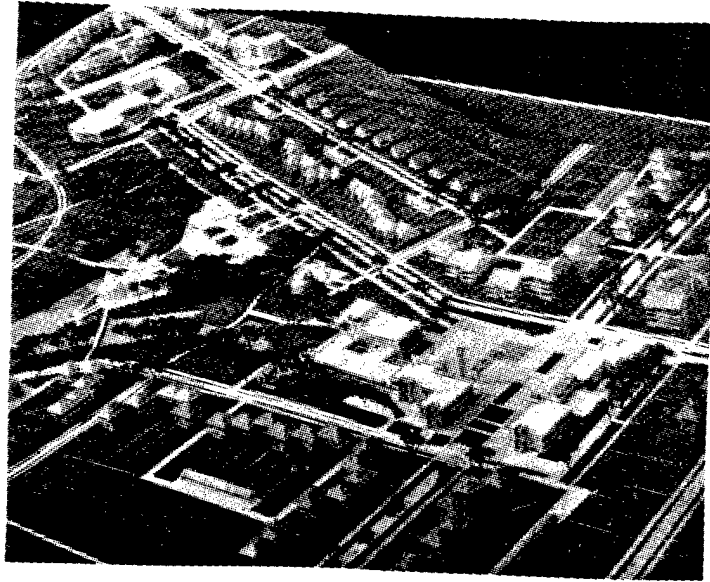

9495  
CSO: 8344/1033



CONSTRUCTION PLANNING AND ECONOMICS

LEAD EDITORIAL REVIEWS INVESTMENT, RECONSTRUCTION POLICY

Moscow EKONOMIKA STROITELSTVA in Russian No 9, Sep 85 pp 1-2, 3-7

Table of Contents and lead editorial: "Based Upon an Acceleration in Scientific-Technical Progress"

Text Table of Contents

For the 27th CPSU Congress -- Worthy Preparations

Based upon accelerated scientific-technical progress..... 3

Strategic Levers of Intensification

"Scientific-Technical Progress-85". At the USSR VDNKh Exhibition of Achievements of the National Economy of the USSR/..... 8  
Balakin, V.A. Improving the organizational forms for administering contractual construction..... 12  
Matvienko, V.P. Financial-economic mechanism and problems concerned with intensification of the economy..... 21  
Shreyber, A.K. Scientific-technical council and accelerating the introduction of new equipment..... 25  
Zhgirov, M.V. Motivating all participants in construction to achieve economies in use of material resources..... 29

Economic Education for Builders

Assistance for those undertaking the course entitled "Administration of Scientific-Technical Progress Under the Conditions Imposed by Developed Socialism"  
Curriculum..... 33  
Principal literature for the course..... 34

First year of instruction. Theme 1

Loginov, V.P. CPSU program for organically combining the advantages of developed socialism with the achievements of scientific-technical progress..... 35

Second year of instruction, Theme 5

Kravtsov, I.I. Administration of scientific-technical progress, renewal of the production apparatus..... 42

Planning and Cost Accounting

Provisional methodological instructions for planning labor productivity under conditions involving a change in the level of material expenditures..... 49

Bogatyrev, A.F. Planning labor productivity based upon comparable work in terms of the level of material intensiveness..... 55

Economics of Labor

School for stimulating labor

Provisional correction factors for the volumes of construction-installation work, for defining the wage groups for leading workers and engineering and technical personnel of construction, construction-installation, specialized, finishing, repair construction, restoration and other equivalent organizations, taking into account the specific nature and the labor intensiveness of the work..... 65

At the USSR VDNKh

New industrial types of finishings for enclosing structures..... 71

Critique and Bibliography

Gorgoshidze, G.N. Social factors in the development of construction..... 72  
Bookshelf..... 70

From Letters To the Editorial Board

Gassul, V.A. POISK-2 System -- the further development of calendar planning in construction-installation organizations..... 74

Economic Consultation

Readers' requests..... 76

Sharp corners of a "roundtable." Meeting with readers of journal concerning problems of construction administration..... 78

In the ministries, departments and institutes..... 41, 75, 77

UDC 69.003:658.011.8

Lead Editorial: Based Upon an Acceleration in Scientific-Technical Progress.

The April (1985) Plenum of the CPSU Central Committee and the conference on matters concerned with accelerating scientific-technical progress, which convened on 11-12 June in the CPSU Central Committee, confronted the party and the Soviet people with the task of accelerating substantially the rates of

economic growth, while placing emphasis in all of our work on intensifying the economy based upon scientific-technical progress, reorganizing in every possible way administration, planning and structural and investment policy and improving organization, discipline and the style of work. Each element in the political system of our society must carry out its functions in an efficient manner, raise still further the leading role played by the party and intensify its influence on all sectors of state, economic and socio-cultural construction. Such direction was provided by the July (1985) Plenum of the CPSU Central Committee.

Our successes in economic development are unquestionable and generally recognized. This is a manifestation of the advantages of socialism and its planned economy. At the same time, we were unable to avoid those difficulties which arose owing to the fact that the required degree of persistence was not displayed in reorganizing structural policy, the administrative forms and methods and the psychology of economic activity. The numerous shortcomings which persist in this very important branch of the national economy reveal what this has done to capital construction.

At times, the plans embody ineffective technological solutions and, as a result, the number of work positions increases and the output-capital ratio decreases since production mechanization is being introduced only slowly and the proportion of manual labor is declining at low rates. Construction is proceeding slowly as a result of a great dispersion of the resources and equipment of the builders. At the same time, well known miscalculations are causing new enterprises to lie idle and quite often owing to the fact that the construction is not being carried out in a complete manner and there is a lack of a production infrastructure -- transport, communications and logistical supply -- and this has aggravated the problem. The sphere of capital repair has grown to an excessive degree. Poor use is being made of secondary resources in the national economy and there has not been sufficient development of resource-conserving technologies. In the interest of achieving higher goals with fewer expenditures, improvements are required in the structure and quality of the construction materials.

An acceleration in the country's socio-economic development must be achieved based upon scientific-technical progress. Moreover, we have in mind here not just simply an increase in the national economic rates of growth, but rather a new quality in economic development. A requirement exists for carrying out a structural reorganization of production and converting the entire national economy, each branch and each enterprise and construction organization over to the path of intensive development. This must be promoted by new and effective administrative forms and by improvements in investment policy, planning and in the entire economic mechanism. Only if this is done will we be able to realize rapid progress in connection with the strategically important trends in economic development.

In order to achieve this, a number of measures must be carried out aimed at changing the minds and moods of the personnel from top to bottom. Our economic and administrative personnel, both in the center and in the various areas, must understand the vital need for reorienting each enterprise, branch and the entire national economy towards the intensive path of development. All of the reserves for raising production efficiency must be placed in operation.

A chief unused reserve is that of putting everything in proper working order. And here it will be necessary to display a great amount of exactingness. At the present time, there is indeed a shortage of exactingness.

Capital construction has a great role to play in the renovation of the national economic production apparatus. The status of affairs in capital construction must be evaluated from the standpoint of scientific-technical progress. This requires the restoration of order in construction planning, a concentration of capital investments, observance of the normative schedules for the erection of installations and the transformation of construction production into a single industrial process.

A need exists first of all for reorganizing investment policy. The existing stereotype of management, under which the principal method for expanding production is considered to be new construction, must be rejected without hesitation. The continuation of such a policy threatens once again to confront the country with tremendous unjustified expenses. The reorganization of investment policy must be based upon a change in the capital investment ratios in the extractive and processing branches and upon not "spreading" the capital investments but rather concentrating them in the most economic directions. Emphasis must be placed upon technical re-equipping, thrifty use of resources and raising output quality sharply, which is the chief summary indicator for scientific-technical progress, culture and labor discipline. The proportion of resources to be used for modernization should be raised from one third to a minimum of one half of the capital investments.

The new technical modernization of the national economy requires tremendous capital investments. Thus resources will have to be maneuvered and concentrated in the key directions. Machine building will play a key role. During the 12th Five-Year Plan, it will be necessary to raise the rates of growth for machine building by a factor of 1.5-2 and carry out the modernization of the branch in a manner so as to ensure the production of new generations of highly productive equipment. In the process, it will not suffice to have merely any type of production renovation, but rather it must be of a type that is based upon the use of advanced equipment. The task has been assigned of carrying out a general inventory of the productive capital and outlining a program for the modernization of each enterprise and each branch, while bearing in mind that the proportion of obsolete capital removed must be doubled. This latter point is of extreme importance to construction, where there are large amounts of obsolete and low productivity equipment still in operation.

A very important problem at the present time is the need for handling new construction properly: accelerating the erection of some construction projects and halting or even limiting in scope the erection of others.

The question of providing the construction projects with equipment arose some time ago and has been discussed repeatedly. Under conditions wherein scientific-technical progress is viewed as a vital task, the complete supplying of equipment, its installation, start-up and adjustment and development to its planned capability are considered to be means for realizing the idea of production intensification. And here, as nowhere else, a requirement exists for reorganizing existing practice. The task of supplying new construction

projects and modernized and re-equipped enterprises with sets of equipment, installing it and adjusting the equipment and bringing it to its planned capability can be carried out by leading enterprises -- producers of the equipment and not outside organizations, as is the case at the present time. The machine builders and enterprise-clients must be primarily responsible for whether or not the products produced by machine building are utilized effectively in the country's national economy. And the time is at hand to put an end to the opposition by the machine builders and the lack of decisiveness on the part of the planning and supply organs in this important work. This would aid in realistically intensifying the influence of the consumers of the machine building products on the final results and on both the quality of the equipment and on the corresponding parameters for the products produced with the aid of this equipment.

Life requires the thorough reorganization of planning, administration and the entire economic mechanism. A great deal has been said in this regard, many recommendations have been introduced and a number of decisions adopted. However, the work is proceeding slowly and the problems are accumulating, since many of them are not being carried out completely. Such was the case, for example, with the well known statute concerning the title lists for construction projects being unchanging planning documents for the entire period of construction (Point 38 of the 12 July 1979 decree concerning improvements in the economic mechanism). The adoption of this decision had as its goal, with the aid of a simple and effective mechanism, that of terminating the incessant appetites of certain branch leaders who strive to expand production operations only through increasing amounts of new construction. However, neither the planning or controlling organs, nor the leaders in the various areas lacked persistence in carrying out the adopted decision and indeed it must be admitted in all sincerity that another adequate or better method did not exist: if the clients are not able to open or close a construction project at their own discretion and work once started must be completed willingly or unwillingly, responsibility for one's recommendations with regard to new construction will appear and perhaps a desire to devote better thought to modernization. In all probability, this problem could have been solved if another statute had been implemented in actual practice: raising the responsibility and independence of the principal cost accounting element -- enterprises which themselves are obligated to earn the means required for technical development. Thus, a vital task today is that of making the economy more receptive to scientific-technical progress and interesting all elements of the national economy in accomplishing this.

A need exists in economic practice for converting over from a large-scale experiment to a general economic one using a new approach. This actually signifies a sharp reduction in the number of centrally established planning indicators, legislative control over the work of enterprises and organizations with the aid of economic norms and radical improvements in price formation so as to create an "anti-expenditure" economic mechanism. A mechanism is needed at the present time which will ensure true advantages for those collectives which achieve success in introducing scientific-technical progress. This must be promoted by a structural reorganization of administration. The structure must be improved in a complete manner -- both vertically and horizontally. Appropriate methodological statutes have been developed and made available to the

branches and territories. But their specific implementation is being carried out not only more slowly than required by national economic interests, but not even according to the plan. This has to do with the problem of stages and the consolidation of an organization. And yet an increase in the role played by trusts and enterprises in eliminating surplus administrative elements and subordinating them directly to the ministries is indeed real. This requires an improvement in the structure of organs of republic administration and a change in the role and functions of the ministries. It must be followed by long-range planning for branch development and by the introduction of innovations on an extensive scale. The agenda also includes the creation of administrative organs for large-scale national economic complexes.

The reorganization of an organic structure must be combined with an increase in cost accounting and an improvement in stimulation. The collective contract must be introduced into operations in a more bold manner, thought must be given to measures for stimulating public recognition of scientific and engineering labor, the "zone of services" must be expanded and wages raised and a close relationship must be established between operational results and wages. Some of these problems have already been resolved in directive and methodological documents concerned with the implementation of the well-known decree on bringing about improvements in the organization, wages for and stimulation of labor in construction, which readers of the journal became acquainted with in the column entitled "School for the Stimulation of Labor."

A chief concern, and one which must be understood by all, is that work concerned with improving the economic mechanism cannot be postponed, since time is running out.

In solving the problem concerned with accelerating scientific-technical progress, an important role is played by science, including branch science, and raising the operational efficiency of scientific-research organizations. A large reserve is the VUZ science. The VUZ's can increase the volume of scientific studies by a factor of 2-2.5. At the present time, the major portion of scientists engaged in carrying out studies for the construction branch, including economic studies, is concentrated at higher educational institutes. But these studies are disconnected and not adequately coordinated. A need exists for "inventorying" these studies, uncovering the scientific interests of the institutes, departments and individual scientists and taking into account all of the forces, the dispersion of which is at times in conflict with the organization and completeness of the studies. And the reserves here are considerable. They include the "second half" of the workload of teachers and economic contract themes.

The scientific and industrial potential of Moscow and Leningrad, Sverdlovsk and Chelyabinsk, Kharkov and Donetsk, Novosibirsk and Omsk, Gorkiy and many other cities and regions throughout the country must have an effect with regard to accelerating scientific-technical progress in the national economy.

Improvements must be carried out in the organizational-economic forms of integration for science, engineering and production, to include the inclusion of scientific and planning institutes in scientific-production associations.

Special importance is attached to improving rationalization and inventive work in the collectives, to finding forms for selecting the best inventions and proposals and for improving work with efficiency experts.

A decisive factor in any endeavor is the people or personnel involved. A vital task of the present stage in national economic development is their training and retraining, especially in connection with new and promising trends. The carrying out not only of the construction program but an acceleration in the development of the branch and improvements in its technical level are dependent upon the degree to which the cadres of leaders, engineering and technical workers, office workers and the brigade leaders of construction organizations are trained. The training of specialists for construction, both at higher and secondary specialized educational institutes and within the system for improving skills, including technical and economic training at enterprises and in construction organizations, must be reorganized in a rapid manner.

Future builders must be taught to think in a technologically correct manner, to organize the construction production process on a modern basis and to administer it efficiently.

The system for raising the skills of construction leaders and specialists must be reorganized in a decisive manner. It is not simply a matter of informing a particular category of specialists, during the next scheduled meeting, regarding the changes which took place within the branch over a definite period of time, but rather it requires the training of specific workers for specific tasks in the future -- this then is the task which must be solved by those institutes and faculties charged with improving skills, jointly with the corresponding services of the construction ministries. This signifies that the ministries, based upon their future tasks, must organize their work concerned with the selection, placement and improving the skills of personnel in a manner such that the key positions in the management of construction production will always be occupied by competent, industrious and high principled workers, individuals who were provided with timely and appropriate training, by order of the ministry, within the system for improving skills or directly in a construction organization.

Everything must be based upon the fact that greater demands will be placed upon the economists, economic executives and engineering-technical and scientific personnel for carrying out important changes in the national economy.

Importance is attached to carrying out constant improvements in the economic training of agricultural specialists. The system of economic education for builders must instill in each branch worker a sense of being the master of the situation, responsible for the effective conduct of affairs, for accelerating scientific-technical progress and for disseminating on an extensive scale all of the new and leading developments being advanced by science and practical work.

The catalyst for the process is the entire information industry. Information work must be organized properly in each trust and enterprise. The specialists must be made acquainted, on a regular basis, with the new developments in technology and the construction production industry and with the discoveries, inventions and efficiency expert recommendations. To the degree that it is able to, the journal EKONOMIKA STROITELSTVA will participate in this work.

A new section will be started in this issue of the journal -- "Strategic Levers of Intensification" -- in which the Editorial Board intends to include articles on accelerating scientific-technical progress throughout the branch, improving administration and the economic mechanism, disseminating leading experience in construction organization and management, raising the level of training for construction personnel and other vital trends.

During the oncoming 1985/86 academic year, the journal will publish training and methodological materials in keeping with the course: "Administration of Scientific-Technical Progress Under the Conditions of Developed Socialism." The lectures for this course will be published in 1986 by Stroyizdat, for use in the system for the economic education of builders.

The end of the 11th Five-Year Plan is close at hand. Our Soviet people are expecting a great deal from the builders. In the time remaining before the end of the year, efforts must be concentrated on the start-up capabilities and on the complexes and projects. The national economy must be provided with all of the projects which were supposed to be placed in operation in accordance with the plans.

In short, a great amount of work still lies ahead -- innovative, large-scale and difficult tasks. They require from each individual a great amount of thought, tense labor, concentration and conscientiousness.

Today the task concerned with accelerating the country's development has become of great political, economic and social importance. The implementation of this task involves urgent work of all-party and national significance.

COPYRIGHT: Stroyizdat, 1985

7026

CSO: 1821/52



CONSTRUCTION PLANNING AND ECONOMICS

TABLE OF CONTENTS, EKONOMIKA STROITELSTVA OCT 85

Moscow EKONOMIKA STROITELSTVA in Russian No 10, Oct 85 pp 1-2

[Text] Strategic Levers of Intensification

For the 27th CPSU Congress -- Worthy Preparations!

Podshivalenko, P.D. To find sources for capital investments for new modernization of the economy.....	4
Yefimov, G.Ya. Raising the quality of construction -- a condition for production intensification.....	13
Mekhtiyev, I.A. From experience in lowering the material-intensiveness of construction.....	20
Seleznov, S.V. Creating a real source for stimulating labor.....	22

Economic Education of Builders

Assistance for those studying the course "Administration of Scientific-Technical Progress Under the Conditions of Developed Socialism.....

First year of instruction. Theme 2

Vileyskiy, M.A. Raising the Socio-economic effectiveness of scientific and engineering development.....	28
---	----

Second year of instruction. Theme 6

Zubkov, V.G. Automatic control systems in construction and planning and the effectiveness of their use.....	35
---	----

All-Union Socialist Competition for Builders

Concerning leading experience

Zaytsev, V.M. Utilizing intra-production reserves of intensification.....	40
---	----

Economies in Construction Resources

School of economic management

Tychkov, Yu.V. Method of management -- a regime for thrift.....	44
---	----

Planning and Cost Accounting

Ilyin, N.I., Gnitsevich, A.P. An analysis of the reserves for construction production, based upon a study of fluctuations in its volumes..... 47  
Safonova, E.I. Balance of the plans for construction production with the capabilities of construction-installation organizations in a time regime..... 51

Economics of Labor

School for stimulating labor

Pak, Yu.Ye. New development in issuing of bonuses for placing projects in operation and results of economic activity..... 54  
Situation with regard to issuing bonuses to workers for placing in operation production capabilities and construction projects..... 56

At the USSR\_VDNKh /Exhibition of Achievements of the National Economy of the USSR/

Glass pipelines..... 79  
Meetings, schools, seminars..... 4th page of cover

Critique and Bibliography

Kondrashov, A.V. Book on foreign experience in construction intensification 67  
Oleynik, P.P. Raising the efficiency of large-panel housing construction... 68  
Bookshelf..... 34, 39, 46, 53

From Letters To the Editorial Board

Mail of the journal..... 70

Economic Consultation

The readers ask..... 73

Information

For each construction project -- exemplary order. Results of the All-union Public Competitive Inspection..... 76  
In the ministries, departments and institutes..... 69

COPYRIGHT: Stroyizdat, 1985

7026  
CSO: 1821/52

CONSTRUCTION MACHINERY AND EQUIPMENT

INTRODUCTION OF NEW, HEAVY CONSTRUCTION MACHINERY REPORTED

Moscow EKONOMICHESKAYA GAZETA in Russian No 25, Jun 85 p 13

[Article: "Assembly of Large-scale Units"]

[Text] A large group of specialists, scholars, trust group workers of the scientific research institute MINMONTAZHSPETSSTROY was nominated for competition for the 1985 prize of the Soviet of Ministers of the USSR for the development and introduction of new heavy hoisting equipment and techniques for installing heavy, large-scale production string equipment. These new methods permit the assembly of equipment and instrumentation that is fully pre-fabricated, which is particularly important for the petrochemical, chemical and petroleum refining branches of industry, which rely on column-type units 100 meters high or more and having a mass of 1000 tons. New tower-type hoist equipment of 500 and 1000 ton capacity, hydraulic hoists of 400 and 500 ton capacity, as well as the effective methods and means for raising load-lifting specifications have been developed, manufactured and introduced. The introduction of the enumerated methods and the new progressive construction technology ensures a decrease in work time and an increase in labor productivity by 40-60 percent. Seventeen inventions were utilized in the creation of this equipment, resulting in an overall savings of one million rubles. In the photo [not shown]: Hoisting of production string equipment.

13101/12790  
CSO: 1821/020

CONSTRUCTION MACHINERY AND EQUIPMENT

DELAYS AT KRASNOYARSK HEAVY EXCAVATOR PLANT EXAMINED

Moscow PRAVDA in Russian 30 Jul 85 p 2

Article by V. Prokushev, Krasnoyarsk: "Following the First Stone"

Text On a summer day in 1978, not far from the kray center and on a large green field, a number of bulldozers formed a line. A flag was waved and the blades of the machines dug into the ground. Simultaneously, the pile drivers commenced operating. Thus the "first stone" was laid in the foundation of the future giant -- the Krasnoyarsk Heavy Excavator Plant.

It is difficult to exaggerate its importance. Such rapidly growing coal centers as Ekibastuz, KATEK and Neryungri require increasing quantities of powerful and reliable equipment. This equipment must be produced by the new plant -- the first specialized enterprise for the production of crawler-mounted and walking excavators and rotary complexes. Its capabilities can only be compared to Uralmash Ural Heavy Machinery Plant imeni Sergo Ordzhonikidze.

Today the buildings for machine-assembly departments, welding structures, non-standard equipment, a boiler and other objects were turned over for operations, while the settlement of Solnechnyy continues to grow. Over the past 3 years, 12 excavators were released from the departments and are now in operation at KATEK Kansk-Achinsk Fuel-Energy Complex and the plans for this year call for the production of eight EKG-12.5's and one walking excavator. One additional walking excavator is to be built next year.

One could take pleasure in the successes if he did not glance at the control figures and schedules. And they are as follows: the first phase of the plant should have been placed in operation on 1 July 1984 at a cost of more than 1 billion rubles and it would have produced, during last year alone, 60 EKG-12.5 drag-line excavators and four rotary complexes each with a productivity of 5,000 tons of bulk per hour. Of six buildings, only four have been turned over for operations, motor vehicle and railroad approach roads have not been completed and the lines for supplying heat, water, gas, compressed air and electric power are being operated on the basis of temporary plans. Equipment valued at 70 million rubles is lying inactive, with one third of this equipment being imported.

These are all immobilized values. Understandably, they furnish no return. Why is this happening?

The construction of the excavator plant was planned as a model-demonstration experiment. USSR Mintyazhstroy /Ministry of Heavy Construction/ proposed that an experiment be carried out for high-speed flow-line construction based upon the use of planning, technical and organizational achievements. In view of the fact that the norms for the duration of construction were obsolete, it was decided to erect the first phase of the plant in just 66 months instead of the normative 111 months, that is, to reduce the construction time by a factor of 1.7.

Dozens of specialists created a special purpose all-round construction program for the plant. There is even an "A-plan" which provides almost an hourly schedule indicating which mechanism is to be used and where and also when a particular mechanism is to be placed on its base.

The recommendations of the Krasnoyarsk workers were approved by USSR Gosstroy and USSR Gosplan. In short, the construction project strategy is based upon three factors: a plan from a sheet of paper, panels from a production line and installation from wheels.

Let us interpret this formula. Today a plan for even a comparatively small enterprise is prepared over a rather extended period of time. It is subsequently examined by the client and thereafter returned for further revisions, which require another year's time. In order to shorten the schedules for the excavator plant, the decision was made to carry out the planning for individual objects simultaneously with the construction.

And how was the work to be carried out in kind? A high degree of industrialization in carrying out the work was called for. It is one thing, for example, to install roofing at a height of almost 100 meters and another to do so on the ground. It was proposed that large units be started on a production line using ventilation units, wiring and pipelines and subsequently to raise it upwards in its entirety. The use of new methods and structures, the rejection of "damp" processes and brick laying -- all of these factors must serve to lower the labor-intensiveness by almost 500,000 man-days.

And finally, the installation of equipment from wheels. The program called for the simultaneous carrying out of the zero cycle at the site of the future department and all of the technological foundations for the equipment. This was proper, since the equipment could be used without interference. Later the walls and roofing were moved up to the prepared foundations. The machines delivered strictly according to schedule by rail are unloaded from the flat cars into the department and following a brief interval of time are connected up to the operations. As a result of such operational efficiency, an intermediate warehouse was even selected from the plan: why store the equipment somewhere if it can immediately be placed in operation?

Such were the plans. During the first two and a half years the work proceeded quite well. Using the simple and costly zero cycles, the builders installed the walls of the first departments ahead of the normative schedules. The

Glavkrasnoyarskstroy base is capable of supplying adequate quantities of the materials needed. But a requirement existed for light-weight metal structures not produced in Krasnoyarsk. They had to be supplied by other enterprises of USSR\_Minmontazhspeystroy /Ministry of Installation and Special Construction Work/ and USSR Mintyazhstroy. And disruptions and delivery delays began to take place. Moreover, at times tens of thousands of tons of structures accumulated at the site and yet they could not be used owing to the fact that they did not come in complete sets. Thus the idea of production line assembly of wall and roofing units was undermined.

But these were minor problems. Waste and work problems became the true scourge of the construction project and they caused considerable losses in time and resources and in disruptions in labor organization from top to bottom. The leading cause was mistakes by specialists, the general planner Uralgiprotyazhmash, the leading institute for construction -- the Moscow Promstroyproyekt and also KrasnoyarskpromstroyNIIproyekt.

They still had approximately 40 planning institutes and organizations operating on a sub-contractual basis. For many of them, the orders came like bolts from out of the blue, in excess of the limit. Located thousands of kilometers from the Siberian construction project, the planners were not familiar with its conditions and their work was carried out in a hurried manner. Delays took place in the issuing of plans and mistakes were tolerated. The client -- the board of directors for the enterprise under construction -- did not trouble itself to examine the plans thoroughly and in fact there was no time for conducting such an examination. The builders were in a hurry. A group of institute representatives with the right of exercising a decisive vote should be in operation at the plant. Such a group exists but it appears only as a consultative intermediate link between the contractors and planning organizations.

Hardly had the builders departed the pumping station building than its wall began collapsing, destroying pipes and cast iron bolts. The walls of three reservoirs fell to the ground before one's eyes. A similar development was reported occurring at a step-down sub-station. The building had to be dismantled and thus a loss of 300,000 rubles was sustained. The cause derived from the fact that the geologists had not studied the ground thoroughly.

The installers also encountered blind alleys from time to time: in accordance with the plan, they order parts and yet a check reveals that they ordered only one half of the amount actually required. Moreover, they do not always receive the exact parts ordered. But even in those areas where the plans were correct, the builders themselves made a "contribution," by disrupting the technology for productive operations. Roofing was installed on the building of the department for non-standard equipment, but only in two layers rather than in four as required. The roof leaked and the repairs cost 1 million rubles.

A new wave of problems accompanied the delivery of equipment. The idea of installation "from wheels" collapsed at the very outset. This occurred mainly owing to the fact that the builders had fallen behind in erecting the buildings. Moreover, they did not succeed in pouring the foundations as planned. Indeed, it was necessary to know in advance exactly which machines

were to be operated in the departments and to have their technical certificates together with the planning tasks. The client was unable to carry out this task. And thus it became necessary to move the equipment into the finished buildings and to dig the foundation pits. In those areas where 100 individuals could handle the work, 400 more were assigned. A foundation was made for which a certificate existed and one could only guess as to what machine would be installed alongside. The concrete foundations were poured and then it was later discovered that they were not as they should be, at which point the cry "break out the mallets" was heard.

Counting on the rapid placing in operation of the first phase and in accordance with the work-orders, the equipment arrived in a stream. The peak occurred in 1983, at which time there was an accumulation of various types of machines valued at 136 million rubles. Since no provision had been made for warehouses, this costly electronic equipment was stored outdoors. Later a requirement developed for creating a special subunit which could search through this abundance of equipment and find the required machine. Some items were defective and others were incomplete. The state sustained great losses.

All of this hampered labor organization and discipline and it did nothing to strengthen the collective. The brigade of Vladimir Bekker -- the initiator of a movement for open contracts -- was well known during the initial years. But later Bekker could not endure the confusion and the transferring of the brigade from one place to another and he left the construction project. It turned out that his successor, Vladimir Vysotskiy had stronger nerves, as he continues to struggle for an open contract.

"As a result of constant reductions in supply, the administrative leaders are unwilling to sign contracts" explained the manager of the Krasnoyarsk-ekskavatorstroy Trust V. Kruglikov, "Indeed, subsequently they must be carried out and there is no material base available for doing so. But today the situation has changed and an open brigade contract must be operated at maximum capability."

At the plant's site, we met with the deputy minister for the construction of heavy industry enterprises P. Selskiy.

"For the very first time over an extended period of time, the semi-annual plan for the construction project has been fulfilled" stated Petr Petrovich, "the project has been supplied completely with all of the materials needed. A need exists here only for greater organizational ability and executive discipline."

The new schedule for placing the first phase of the plant in operation is 1988. This would then be the 111 normative months since the beginning of construction, with an attempt having been made to reduce the construction time by a factor of 1.7.

The construction project, which from the beginning has been referred to as being a model one, is following the usual channel. The idea of high-speed flow-line construction has become bogged down in a multitude of planning, organizational and supply problems. To a large degree, this occurred mainly as a result of miscalculations on the part of Mintyazhmash /Ministry of Heavy and

Transport Machine Building/, Mintyazhstroy /Ministry of Construction of Heavy Industry Enterprises/, USSR Gosstroy and also local organs. And it is believed that each department can single out specific culprits guilty of causing delays in this important construction project and see to it that each receives his "just deserts."

The economic mechanism in capital construction must be improved and not by parts but rather in a complete and systematic manner and based upon a single concept. Only then will it be possible to convert construction into a reliable lever for accelerating scientific-technical progress.

7026  
CSO: 1821/53

END