

NATIONAL TRANSPORTATION SAFETY BOARD

WASHINGTON, D.C. 20594

DISTRIBUTION STATEMENT A
Approved for public release;
Distribution Unlimited

AIRCRAFT ACCIDENT REPORT

UNCONTAINED ENGINE FAILURE
DELTA AIR LINES FLIGHT 1288
MCDONNELL DOUGLAS MD-88, N927DA
PENSACOLA, FLORIDA
JULY 6, 1996

19980508 113

DTIC QUALITY INSPECTED 4

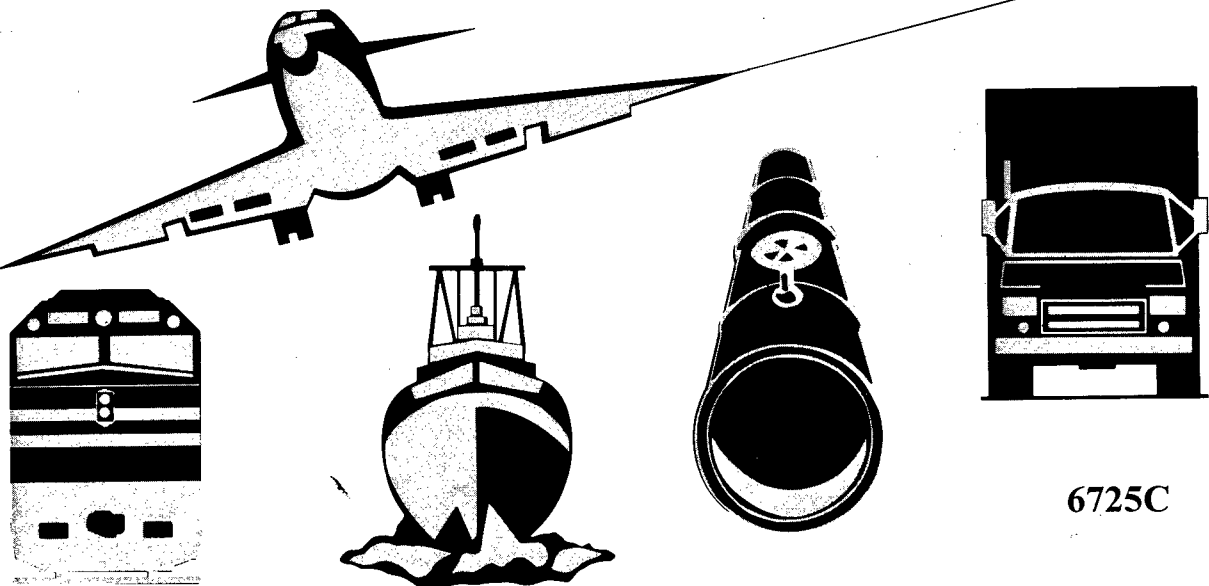

6725C

The National Transportation Safety Board is an independent Federal agency dedicated to promoting aviation, railroad, highway, marine, pipeline, and hazardous materials safety. Established in 1967, the agency is mandated by Congress through the Independent Safety Board Act of 1974 to investigate transportation accidents, determine the probable causes of the accidents, issue safety recommendations, study transportation safety issues, and evaluate the safety effectiveness of government agencies involved in transportation. The Safety Board makes public its actions and decisions through accident reports, safety studies, special investigation reports, safety recommendations, and statistical reviews.

Information about available publications may be obtained by contacting:

National Transportation Safety Board
Public Inquiries Section, RE-51
490 L'Enfant Plaza, S.W.
Washington, D.C. 20594
(202)314-6551
(800)877-6799

Safety Board publications may be purchased, by individual copy or by subscription, from:

National Technical Information Service
5285 Port Royal Road
Springfield, Virginia 22161
(703)605-6000

**NATIONAL TRANSPORTATION
SAFETY BOARD
WASHINGTON, D.C. 20594**

AIRCRAFT ACCIDENT REPORT

UNCONTAINED ENGINE FAILURE

**DELTA AIR LINES FLIGHT 1288
McDONNELL DOUGLAS MD-88, N927DA
PENSACOLA, FLORIDA
JULY 6, 1996**

**Adopted: January 13, 1998
Notation 6725C**

Abstract: This report explains the accident involving Delta Air Lines flight 1288, an MD-88, which experienced an uncontained engine failure during the initial part of its takeoff roll at Pensacola Regional Airport in Pensacola, Florida, on July 6, 1996. Safety issues in the report include the limitations of the blue etch anodize process, manufacturing defects, standards for the fluorescent penetrant inspection process, the performance of nondestructive testing, the use of alarm systems for emergency situations, and instructions regarding emergency exits. Safety recommendations concerning these issues were made to the Federal Aviation Administration.

CONTENTS

EXECUTIVE SUMMARY.....	vi
1. FACTUAL INFORMATION.....	1
1.1 History of Flight.....	1
1.2 Injuries to Persons.....	4
1.3 Damage to Airplane.....	4
1.4 Other Damage.....	6
1.5 Personnel Information.....	6
1.5.1 The Captain.....	6
1.5.2 The First Officer.....	8
1.5.3 Flight Attendants.....	8
1.6 Airplane Information.....	8
1.6.1 Airplane Engines.....	9
1.6.2 Left Engine Compressor Fan Hub Manufacture and History.....	9
1.7 Meteorological Information.....	13
1.8 Aids to Navigation.....	13
1.9 Communications.....	13
1.10 Airport Information.....	14
1.11 Flight Recorders.....	14
1.12 Wreckage and Impact Information.....	15
1.13 Medical and Pathological Information.....	17
1.14 Fire.....	19
1.14.1 Emergency Response.....	19
1.15 Survival Aspects.....	20
1.15.1 General.....	20

1.15.2 The Evacuation	20
1.15.3 Previous Safety Board Recommendations	22
1.16 Tests and Research.....	26
1.16.1 Metallurgical Examination	26
1.16.2 Examination of Volvo's Tierod Hole Drilling Processes.....	31
1.16.3 Review of Fan Hub Inspection Procedures Following Manufacture	32
1.16.4 Followup Drilling Tests Conducted by Volvo	35
1.17 Organizational and Management Information	35
1.18 Additional Information	36
1.18.1 Fan Hub Cleaning and FPI Preparation Processes Used by Delta	36
1.18.1.1 Cleaning	37
1.18.1.2 Dye/Developer Application.....	38
1.18.1.3 Inspection	39
1.18.2 FPI Inspector Training at Delta	40
1.18.3 FAA Oversight and Review of Delta's FPI Process.....	41
1.18.4 FAA Accident/Incident Records on JT8D-200 Engines	43
1.18.5 Safety Board Recommendations Subsequent to the Accident	43
1.18.6 FAA Responses to Recommendations A-96-74 through -77 and Subsequent Safety Board Responses and Actions	44
1.18.7 Related Safety Board Recommendations from the Accident Involving United Airlines Flight 232, Sioux City, Iowa.....	48
1.18.8 Other Uncontained Engine Failures	50
1.18.9 Results of FAA-Sponsored Titanium Rotating Components Review Team.....	52
2. ANALYSIS	55
2.1 General.....	55
2.2 Fan Hub Fracture.....	55

2.3 Analysis of Volvo's Inspection Procedures	57
2.4 Failure of Delta Maintenance to Detect Cracking in the Accident Hub	58
2.4.1 Part Cleaning, Drying, Processing, and Handling	59
2.4.2 Human Factors Related to Inspector Performance	62
2.4.2.1 Lack of a Formal Method to Ensure Completeness of Search and Diagnostic Followup	63
2.4.2.2 Low Expectation of Finding a Crack and Decreased Vigilance	64
2.4.2.3 Inadequate Diagnostic Techniques or Controls	65
2.4.2.4 Adequacy of Inspector Training and Proficiency	65
2.5 Adequacy of Inspection Requirements for Critical Rotating Titanium Components	67
2.6 Maintenance Deficiencies	70
2.7 Crew Actions and Survival Factors	71
3. CONCLUSIONS	74
3.1 Findings	74
3.2 Probable Cause	77
4. RECOMMENDATIONS	78
5. APPENDIXES	81
APPENDIX A—INVESTIGATION AND HEARING	81
APPENDIX B—COCKPIT VOICE RECORDER TRANSCRIPT	82
APPENDIX C—DELTA PROCESS STANDARD 900-1-1	118

EXECUTIVE SUMMARY

On July 6, 1996, at 1424 central daylight time, a McDonnell Douglas MD-88, N927DA, operated by Delta Air Lines Inc., as flight 1288, experienced an engine failure during the initial part of its takeoff roll on runway 17 at Pensacola Regional Airport in Pensacola, Florida. Uncontained engine debris from the front compressor front hub (fan hub) of the No. 1 (left) engine penetrated the left aft fuselage. Two passengers were killed and two others were seriously injured. The takeoff was rejected, and the airplane was stopped on the runway. The airplane, which was being operated by Delta as a scheduled domestic passenger flight under the provisions of Title 14 Code of Federal Regulations Part 121, with 137 passengers and 5 crew on board, was destined for Hartsfield Atlanta International Airport in Atlanta, Georgia.

The National Transportation Safety Board determines that the probable cause of this accident was the fracture of the left engine's front compressor fan hub, which resulted from the failure of Delta Air Lines' fluorescent penetrant inspection process to detect a detectable fatigue crack initiating from an area of altered microstructure that was created during the drilling process by Volvo for Pratt & Whitney and that went undetected at the time of manufacture. Contributing to the accident was the lack of sufficient redundancy in the in-service inspection program.

Safety issues discussed in this report include the limitations of the blue etch anodize process, manufacturing defects, standards for the fluorescent penetrant inspection process, the performance of nondestructive testing, the use of alarm systems for emergency situations, and instructions regarding emergency exits. Recommendations concerning these issues were made to the Federal Aviation Administration.

**NATIONAL TRANSPORTATION SAFETY BOARD
WASHINGTON, D.C. 20594**

AIRCRAFT ACCIDENT REPORT

**UNCONTAINED ENGINE FAILURE
DELTA AIR LINES FLIGHT 1288
McDONNELL DOUGLAS MD-88, N927DA
PENSACOLA, FLORIDA
JULY 6, 1996**

1. FACTUAL INFORMATION

1.1 History of Flight

On July 6, 1996, at 1424 central daylight time,¹ a McDonnell Douglas MD-88, N927DA, operated by Delta Air Lines Inc., as flight 1288, experienced an engine failure during the initial part of its takeoff roll on runway 17 at Pensacola Regional Airport (PNS) in Pensacola, Florida. Uncontained engine debris from the front compressor front hub (fan hub) of the No. 1 (left) engine penetrated the left aft fuselage. Two passengers were killed, and two others were seriously injured. The takeoff was rejected, and the airplane was stopped on the runway. The airplane, operated by Delta as a scheduled domestic passenger flight under the provisions of Title 14 Code of Federal Regulations (CFR) Part 121, with 137 passengers and 5 crew on board, was destined for Hartsfield Atlanta International Airport in Atlanta, Georgia. The crew comprised two pilots and three flight attendants. Two nonrevenue Delta employees, a Delta Boeing 767 pilot and a flight attendant, were also on board seated in the cockpit and aft flight attendant jumpseats, respectively.

The first officer arrived at the airplane at 1330 and began a preflight inspection. As recorded on the cockpit voice recorder (CVR), the first officer stated to the captain, "There's oil coming out of the bullet [nose of the left engine] now." During an interview with Safety Board investigators, the first officer stated that he had observed "two or three drops" of oil on the nose bullet. He stated that the oil "was not dripping" and "did not appear to be at all significant." He also informed the captain of two rivets missing on the outboard section of the left wing. He and the captain discussed these items in the cockpit after the captain arrived at 1345 and the captain told the first officer to log the missing rivets in the airplane's logbook. The captain told Safety Board investigators that he and the first officer concluded, based on the amount of oil the first officer reported seeing, that the airplane was airworthy² and that he therefore elected to

¹Unless otherwise indicated, all times are central daylight time, based on a 24-hour clock.

²Delta's Flight Operations Manual (FOM), Section 7, "Normal Operations: 7-20 Fluid Leaks" states, "The pilot may placard a fluid leak only under the guidance of the maintenance control center and if the following conditions are met: The pilot can identify the type of fluid; the source of the leak can be determined using normal walk around inspection procedures...; [and] the rate of leakage is positively determined (i.e., in drops per

depart without notifying maintenance.³ The left engine was started during pushback from the gate, and the right engine was started during taxi.⁴ The flightcrew said both engines started normally and that there was no evidence of vibration during taxi.

Flight 1288 was cleared for takeoff by the PNS air traffic control (ATC) tower controller at 1423. The first officer, who was the pilot flying, advanced the throttles and called for the autothrottles to be set when the engine pressure ratio (EPR)⁵ reached 1.35. The throttles were advancing in the autothrottle mode when the flightcrew heard a "loud bang," followed by the loss of cockpit lighting and instrumentation. Passengers and flight attendants in the rear of the cabin described experiencing a "concussion or blast-like sensation." The captain took control of the airplane and retarded both throttles to idle. He applied manual brakes and brought the airplane to a gradual stop on the runway. The captain did not command reverse engine thrust, and the ground spoilers were not deployed. There were no cockpit indications or warnings of fire. Flight data recorder (FDR) data (see section 1.11) indicate that the airplane had reached a speed of about 40 knots when the left engine failed.

After the airplane was stopped on the runway, the first officer attempted to contact the tower and the flight attendants but was unsuccessful because electrical power had been lost, rendering the radio and the cabin interphone inoperative. The flightcrew then activated emergency power,⁶ contacted the tower, and declared an emergency at 1425.⁷

The flightcrew told Safety Board investigators that after the airplane came to a stop, the L-1 (forward cabin) flight attendant entered the cockpit and asked if the cabin should be

minute)." The FOM also states, "Unless all of the above conditions are met, maintenance personnel must evaluate the leak and take the necessary corrective action." Section 7-21 adds, "Mechanics may defer items that are not of an airworthy nature." In Section 7-22.2, "Maintenance Irregularity at the Gate—At Nonmaintenance Stations" the FOM states, "At nonmaintenance stations, contact the maintenance control center through the dispatcher. The captain and the maintenance control center must reference the MEL [minimum equipment list] to determine if the item may be placed on the MCO [maintenance carry-over] by the pilots, or if contract maintenance is needed to repair them."

³The captain told Safety Board investigators that he based his decision on the first officer's report that the oil was not dripping, stating, "You know, this was two drops out of 14 quarts." He stated that Delta policy called for captains to determine when maintenance irregularities affecting airworthiness should be reported to maintenance personnel for guidance. Delta did not operate a maintenance facility at Pensacola, but contract maintenance was available.

⁴Delayed engine starts are commonly used for fuel conservation, engine conservation, and noise abatement.

⁵EPR is a measure of engine thrust, comparing total turbine discharge pressure to the total pressure of the air entering the compressor.

⁶Emergency power from the airplane's battery powers selected essential flight and navigational instruments and communications for the life of the battery, which is about 30 minutes.

⁷According to a partial transcript of the ATC tower tape recording.

evacuated.⁸ The captain stated that because there was no cockpit indication of a fire, he told her not to initiate an evacuation. The flight attendant used a portable megaphone to tell passengers to remain seated. The first officer stated that he made a similar announcement on the public address (PA) system after power was restored and that he again attempted to contact the flight attendants with the interphone but was not successful. The cockpit jumpseat passenger then walked to the aft section to inspect the cabin.

Meanwhile, the captain directed the first officer aft to inspect the cabin. The first officer saw that the overwing exits were open, and he heard engine noise. He immediately returned to the cockpit to tell the captain to shut down the engines. The captain then moved both fuel control levers to the "off" position, informed the tower that the airplane was shut down on the runway, and added, "be advised we have passengers [standing] on the runway."⁹ The first officer started back toward the aft section of the cabin again, passing the cockpit jumpseat passenger who was returning to the cockpit to brief the captain on the structural damage and injuries to passengers. At 1427, the captain called the tower and requested medical assistance. He also requested that firefighting personnel inspect the exterior of the airplane for fire. The cockpit jumpseat passenger told Safety Board investigators that he saw a large hole in the left side of the fuselage, debris scattered throughout the aft cabin, and flight attendants assisting injured passengers. He said that he did not see smoke or flames. He stated that about 25 passengers had exited the airplane and that some passengers were on the wings and runway.

As the first officer moved aft through the cabin, he saw that the aft (tail cone) exit and left aft (L-2) door¹⁰ were open. He advised passengers to remain seated and briefly exited the airplane to restrain a passenger who was attempting to jump off the wing, advising her that it was safer to remain on board. The first officer estimated that about half of the passengers had already evacuated the airplane, most of them from seats aft of the wings' leading edges.

The first officer returned to the cockpit and reported to the captain that several serious injuries had occurred, that the airplane had sustained structural damage, and that passengers in the aft cabin had evacuated. The captain then pulled the left engine fire handle.¹¹

⁸After the engine failure, power was lost to the FDR and the CVR, which provides cockpit conversation with a time reference. Emergency power does not restore electricity to these units. Although ATC (and fire department) tape recordings provided some frame of reference, it was not possible to determine precisely when certain events occurred. Thus, the sequence of events after the FDR and CVR were lost was reconstructed based on ATC and fire department records, as well as on Safety Board interviews with flightcrew and cabin crewmembers, and on passenger and witness accounts.

⁹Passengers had begun evacuating the airplane.

¹⁰The L-2 door is the galley service door on the left side of the aircraft, aft of the wing. Overwing exits are removable hatches (two on each side over the wing) that allow evacuation from the top of the wings. The tailcone had been jettisoned, and the aft tailcone slide was deployed. The aft airstairs remained retracted until the first officer extended them to allow emergency personnel to evacuate the injured passengers.

¹¹Pulling the left engine fire handle disables left engine fire warnings, trips the left generator control relay, shuts off fuel and hydraulic supply to the left engine pumps, closes the pneumatic crossfeed valve, and

The captain told Safety Board investigators that he and the first officer again assessed the situation and that he (the captain) repeated his instruction to the L-1 flight attendant not to evacuate the airplane.

The flight attendants who were in the aft cabin had initially initiated an evacuation (based on the serious airframe damage and passenger injuries) after attempting unsuccessfully to contact the flightcrew by interphone. The flight attendants in the aft cabin began the evacuation using the tail cone slide. Three passengers and an infant evacuated using that slide. The L-2 flight attendant then opened the L-2 door and pulled the evacuation slide's manual inflation handle. After pulling the inflation handle, the flight attendant saw fire on the left engine's forward cowling and immediately blocked the exit and redirected passengers forward.

The L-1 flight attendant told Safety Board investigators that she saw "a hole in the aircraft and lots of blood." She advised the captain that "we had an emergency situation and possibly two dead." The L-1 flight attendant said she went back to assist an injured passenger, who had sustained a severe head injury and was being treated by a physician passenger.

Because casualties in the rear of the airplane made deplaning by the aft air stairs unfeasible, the captain asked the tower to send portable stairs to deplane the passengers. The first mobile stairs that arrived were not designed for passenger use and the captain refused to use them. Suitable stairs arrived about 25 minutes after the accident, and the remaining passengers deplaned. They were taken to the terminal area by bus.

The accident occurred in daylight visual meteorological conditions. The airplane came to a stop about 1,350 feet down runway 17, about 30° 28.40' north latitude and 87° 11.25' west longitude.

1.2 Injuries to Persons

<u>Injuries</u>	<u>Flightcrew</u>	<u>Cabincrew</u>	<u>Passengers</u>	<u>Other</u>	<u>Total</u>
Fatal	0	0	2	0	2
Serious	0	0	2	0	2
Minor	0	0	3	0	3
None	<u>2</u>	<u>3</u>	<u>130</u>	<u>0</u>	<u>135</u>
Total	2	3	137	0	142

1.3 Damage to Airplane

The aft left fuselage and interior of the airplane in the vicinity of the No. 1 engine were substantially damaged by debris from the engine (see figure 1). A total of 16 holes, punctures, or tears were documented on the left fuselage skin. Several large holes and tears were

arms the fire extinguisher discharge agent. Turning the handle discharges the extinguisher into the engine. The agent was not discharged into the left engine.

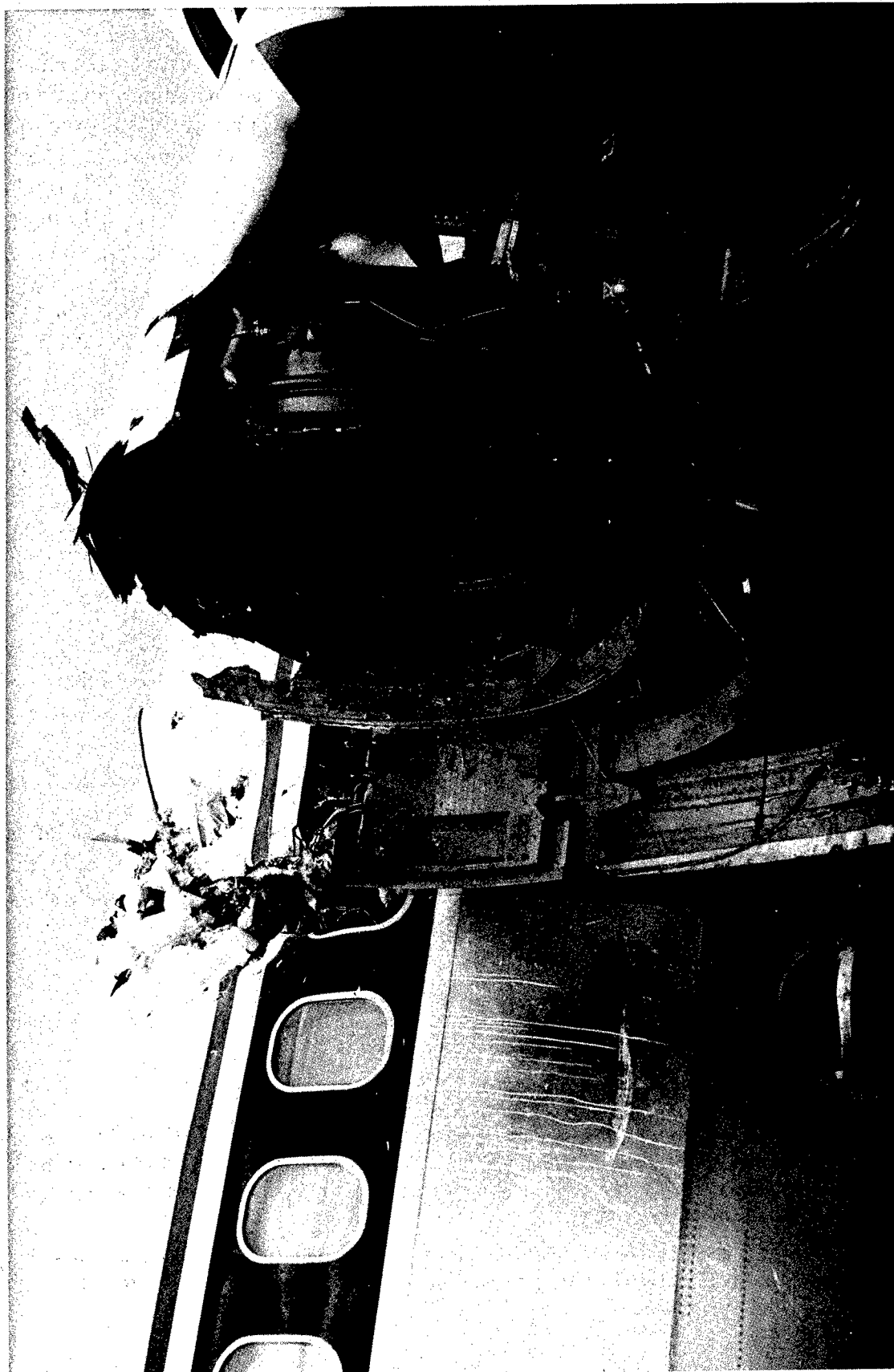

Figure 1.—Damaged area of airplane near No. 1 engine.

found between fuselage stations (FS) 1250 and FS 1282 (adjacent to row 37) and from the top of the window to longeron 2 (see figure 2).¹² Seven exit holes, punctures, and tears were documented on the right fuselage skin between FS 1228 and 1271 (just forward of row 37). Most of the wires in the wire bundle located along longeron 4 (on the right side of the fuselage) were severed near FS 1250. Of the 154 wires in the bundle, 146 had been severed. Four of the severed wires were channel differential protection wires that compared incoming and outgoing current for the right generator.¹³ No evidence of penetrations existed below the floor level on either side of the fuselage.

The cabin interior was substantially damaged near seat row 37, next to the left engine. Debris from the left engine's fan hub and fan blades had penetrated the left cabin wall and overhead bin vertically from the lower left passenger window through the overhead bin and ceiling panel. Engine fan components had also pierced the side and ceiling of the right cabin wall.

The No. 1 engine, a Pratt & Whitney JT8D-219 turbofan, was destroyed.

1.4 Other Damage

No other property damage resulted from this accident.

1.5 Personnel Information

The flightcrew comprised a captain and first officer, who had begun a 3-day trip sequence the day before the accident. The three on-duty flight attendants were also on the second day of a 3-day trip sequence.

1.5.1 The Captain

The captain, age 40, was hired by Delta Air Lines in 1979 and had served as a flight engineer on the Boeing 727 (B-727) and as a first officer on the DC-9, B-727, B-757, and B-767 aircraft. He flew one line trip as a DC-9 captain before transitioning to the MD-88.¹⁴

¹²Longerons are the principal longitudinal structural members in the fuselage. Fuselage stations measure and identify aircraft structural locations along a longitudinal axis.

¹³The four severed wires were connected to differential protection current transformers, which are designed to detect a line-to-line or line-to-neutral fault by sensing and comparing the current flow between the generator neutral side and the load side of the generator bus circuit breakers. When a differential (fault) current of 20 amps to 40 amps is exceeded, the generator control unit differential protection circuit trips the generator relay to remove power from the generator bus. The differential protection circuit is also designed to prevent a properly functioning generating system from being connected to a faulty distribution system.

¹⁴The McDonnell Douglas MD-80 series airplanes were originally certified and designated in the Douglas DC-9-80 series and are larger and more advanced than the earlier DC-9-10, -20, -30, -40, and -50 series airplanes.

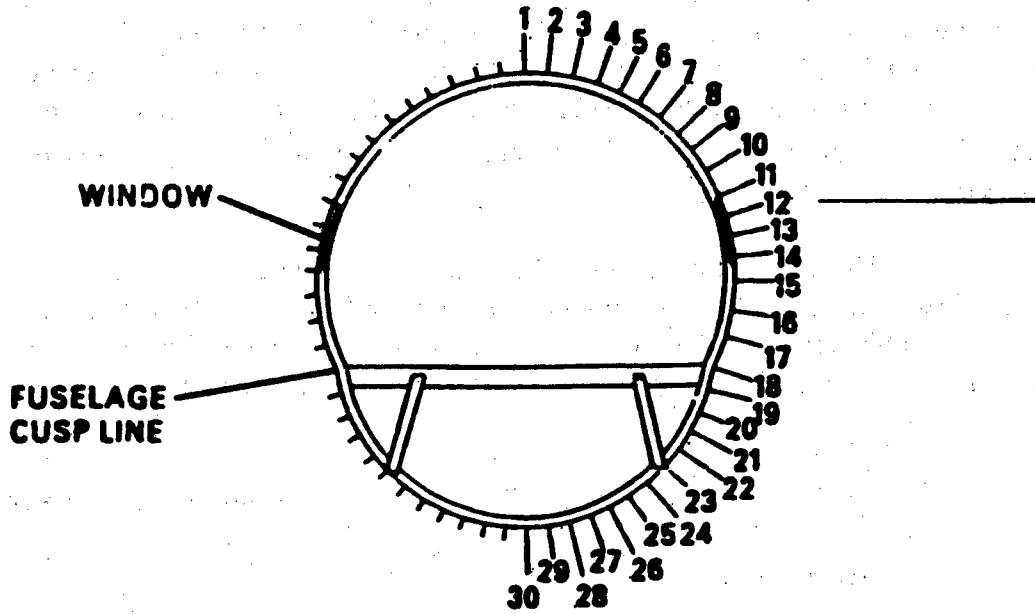

FUSELAGE LONGERON NUMBERING ARRANGEMENT

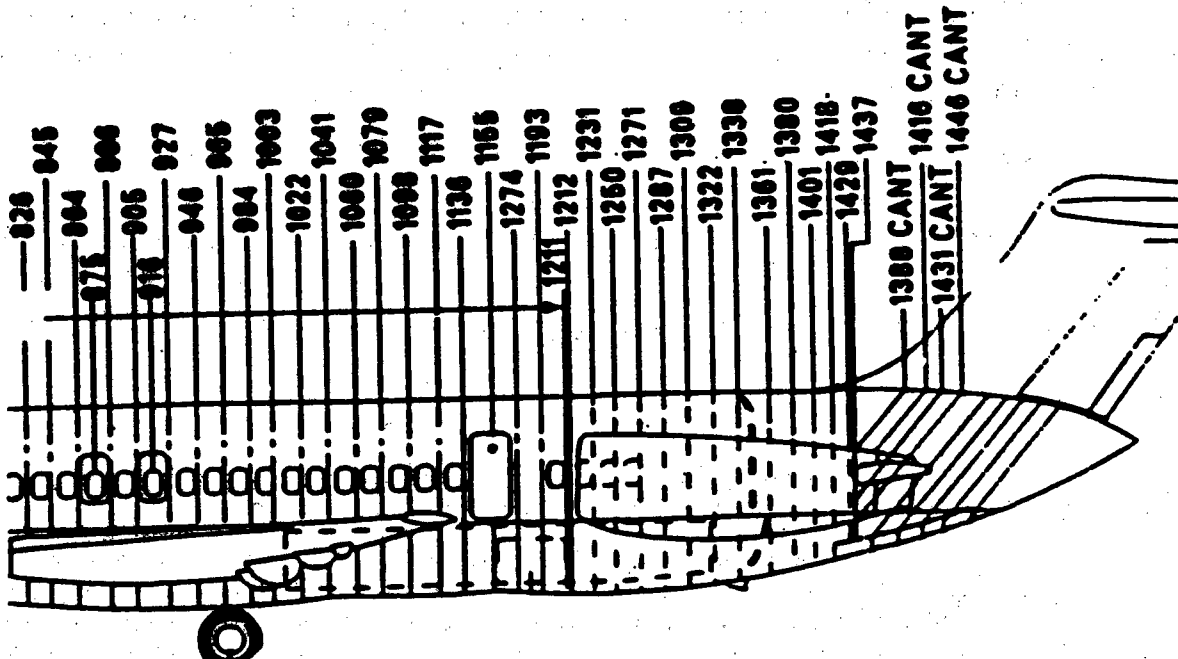

FUSELAGE STATIONS
DC-9-80 SERIES AIRPLANES

Figure 2.—Fuselage station and longeron identifications.

Before being hired by Delta, the captain flew for a commuter airline between 1977 and 1979. He held an airline transport pilot (ATP) certificate with an airplane multiengine land rating and a type rating in the DC-9. His most recent Federal Aviation Administration (FAA) first-class medical certificate was dated January 23, 1996, with the limitation, "Holder shall wear corrective lenses (for distant vision)." He had logged about 12,000 flying hours, of which 2,300 hours were as MD-88 pilot in command (PIC). A search of the FAA's and Delta's records showed no FAA enforcement actions, accidents, incidents, or company disciplinary actions, and a search of records at the National Driver Register found no history of driver's license revocation or suspension. The captain had completed a Delta crew resource management (CRM) course as part of his recurrent training at Delta in March 1996.

1.5.2 The First Officer

The first officer, age 37, was hired by Delta Air Lines in 1990. He first flew as a flight engineer on the B-727 and later as a flight engineer on the Lockheed L-1011. He upgraded to first officer on the B-737 and transitioned to the MD-88 about a year before the accident. Before being hired by Delta, the first officer flew Cessna A-37s and Fairchild Republic A-10 Thunderbolt II airplanes in the U.S. Air Force. He held an ATP certificate with multiengine land and single-engine land ratings. His most recent first-class medical certificate was dated June 21, 1996, with no limitations. He had logged about 6,500 flying hours, of which about 500 hours were in the MD-88. A search of the FAA's and Delta's records showed no FAA enforcement actions, accidents, incidents, or company disciplinary actions, and a search of records at the National Driver Register found no history of driver's license revocation or suspension. The first officer had completed a CRM course as part of his recurrent training at Delta in April 1996.

1.5.3 Flight Attendants

The three on-duty (and one off-duty) flight attendants were qualified on the MD-88 and had completed Delta's initial training, which included instruction on emergency evacuation procedures. The three on-duty flight attendants had also completed annual recurrent training in early 1996, which included refresher training on emergency procedures and evacuation. The recurrent training was conducted during an 8-hour instruction period and included performance-based training. The flight attendants and flightcrew members had completed joint emergency procedures training, which included CRM methodology, during their initial and recurrent training at Delta.

1.6 Airplane Information

N927DA, a McDonnell Douglas MD-88, serial number (SN) 49714, was manufactured in April 1988 and was sold to Delta in November 1988. The airplane was configured to carry 142 passengers (14 first class and 128 coach). At the time of the accident, N927DA had accumulated a total of 22,031 hours and 18,826 cycles on its airframe. It has a maximum takeoff weight of 149,500 pounds, a maximum landing weight of 130,000 pounds, and a zero fuel weight of 118,000 pounds.

1.6.1 Airplane Engines

The airplane was equipped with two Pratt & Whitney JT8D-219 turbofan engines. The JT8D-200 series engine is an axial-flow front turbofan¹⁵ with a 14-stage split compressor,¹⁶ a 9-can combustion chamber,¹⁷ and a split, 4-stage reaction impulse turbine (see figure 3).¹⁸ The No. 1 (left) engine, SN 726984, had a total operating time of 7,371.7 hours and 5,905 operating cycles¹⁹ since new. Delta was the original operator of the engine. The engine had been installed on the accident airplane on January 1, 1996, and had since then accumulated 1,528 hours and 1,142 cycles. It had been removed from another Delta airplane on December 21, 1995, following a report of "smoke in cabin." The problem was identified as an oil leak in the compressor section, and a carbon seal was replaced.

The right engine showed no evidence of failure.

1.6.2 Left Engine Compressor Fan Hub Manufacture and History

The left engine's fan hub, SN R32971, had a total time of 16,542 hours and 13,835 cycles at the time of the accident. At the time of the engine's installation on the accident airplane in January, the hub had accumulated 12,693 cycles. The titanium fan hub was forged by Ladish Company in Milwaukee, Wisconsin, and machined, finished, and inspected for Pratt & Whitney by Volvo Aero Corporation in Trollhattan, Sweden, in January 1989, according to Pratt & Whitney records. The service life of this type of fan hub is limited to 20,000 cycles.²⁰

The hub consisted of a disk forging that held 34 fan blades in dovetail (interlocking joint) slots. The aft end of the hub attached to the stage 1.5 disk with 24 tierods that passed through .5175-inch diameter tierod holes drilled in the hub rim just inside of the

¹⁵ An axial-flow turbine engine has a principal air flow path that is parallel to the engine's longitudinal axis.

¹⁶ A 14-stage split compressor refers to the two counter-rotating shafts in the engine. One shaft drives the low pressure compressor, which consists of seven stages. The second shaft drives the high-pressure compressor, which also has seven stages.

¹⁷ Fuel in the engine is burned in small cylindrical chambers that are mounted between the last compressor stage and the first turbine stage. Each chamber, or can, has its own fuel injector.

¹⁸ In a reaction impulse turbine, power is generated by turbine blades shaped to turn airflow to create a reaction force on the blade. The blades are also shaped so that airflow, under some conditions, can impinge directly on the blade surface, causing a direct force, or impulse.

¹⁹ A cycle is one complete sequence of engine start-up, taxi, takeoff, climb, cruise, descent, landing, thrust-reverse, taxi, and shutdown.

²⁰ A Pratt & Whitney executive responsible for accident investigation and airworthiness testified during the Safety Board's public hearing that the fan hub's service life limit was based on extensive material testing. He stated that it was determined that the hub could "safely take 20,000-start and stop cycles and no more than 1 of 1,000 of those hubs would have [a minute] crack indication in it; and that there was no danger of the part fracturing within the 20,000-cycle life limit."

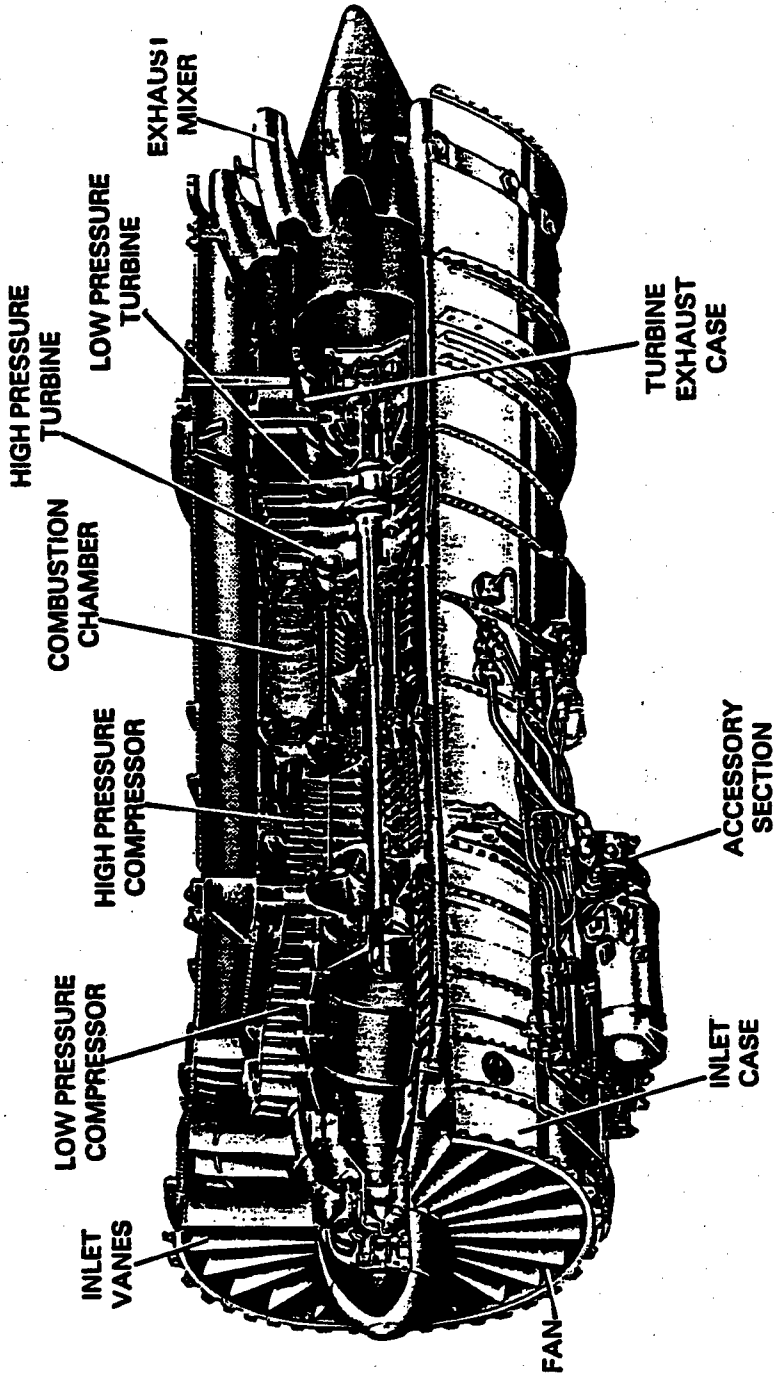

Figure 3.—Cross section of Pratt & Whitney's JT8D-200 series engine.

dovetail slots. The 2.91-inch deep tierod holes were located around the circumference of the hub bore and alternated with 24 smaller diameter stress redistribution (SR) holes (see figure 4).²¹ The fan hub was forged from a titanium-based alloy containing 6 percent aluminum and 4 percent vanadium.

The accident fan hub was first installed on an MD-88 engine at the Pratt & Whitney factory in April 1990. The engine and fan hub were removed from that airplane by Delta maintenance personnel in January 1992, following foreign object damage (FOD) to the fan blades. At that time, the fan hub, which had accumulated 4,456 cycles, was subjected to a visual inspection at Delta after the fan blades were removed.

Delta maintenance personnel told Safety Board investigators that this inspection was performed according to the Pratt & Whitney inspection procedure in practice at Delta, titled, "Front Compressor Front Hub (Stage One) - Inspection-01." Those instructions directed inspectors to inspect "all holes" in the hub and noted that hole bores were to be clean. Inspectors were instructed to mount the hub on a "tilted, rotating holding fixture and to illuminate [the] opposite end of the hole from [the] viewing end." The manual also stated, "NOTE: EACH HOLE MUST BE INSPECTED FROM BOTH SIDES." A section detailing the surface inspection stated that a white fluorescent light and a three-power magnifying glass were to be used to identify surface damage "such as nicks, dents, scratches and corrosion pits." Safety Board investigators who attempted to inspect a hole using these tools noted that the limited focus length of the magnifying glass and glare from the white light prevented them from viewing details of the hole walls.²² A Delta maintenance representative told Safety Board investigators that the hub's visual inspection is also called a "shop visit." No reworking of the part occurred after the inspection.

The accident fan hub was installed on another engine in March 1992, according to Delta maintenance records. It was removed from this engine on September 24, 1995, after it had accumulated 12,693 cycles and the hub assembly underwent "heavy maintenance," according to Delta's JT8D-219 engine maintenance management plan (EMMP). This maintenance work included a fluorescent penetrant inspection (FPI)²³ and visual nondestructive testing

²¹ Stress redistribution holes are also referred to as balance weight holes, cooling holes, lightening holes, or shielding holes.

²² After the accident, Safety Board investigators suggested that Delta use hand-held borescopes to view the inside of holes during visual inspections, and Delta has indicated that it now uses these devices.

²³ FPI is an inspection technique for checking part and component surfaces for cracks or anomalies. The technique involves applying a penetrant fluid (a low viscosity penetrating oil containing fluorescent dyes) to the surface after it has been cleaned and allowing it to penetrate into any surface cracks. Excess penetrant is then removed and a "developer" is applied to act as a blotter and draw the penetrant back out of any surface cracks. This produces a fluorescent indication of cracks or anomalies when viewed under ultraviolet lighting. FPIs "can only be used to detect surface defects and subsurface defects that are open to the surface," according to an FAA definition contained in the "Titanium Rotating Components Review Team Report," dated December 14, 1990. The definition added that a "true indication occurs when penetrant bleeds back to the surface from a discontinuity."

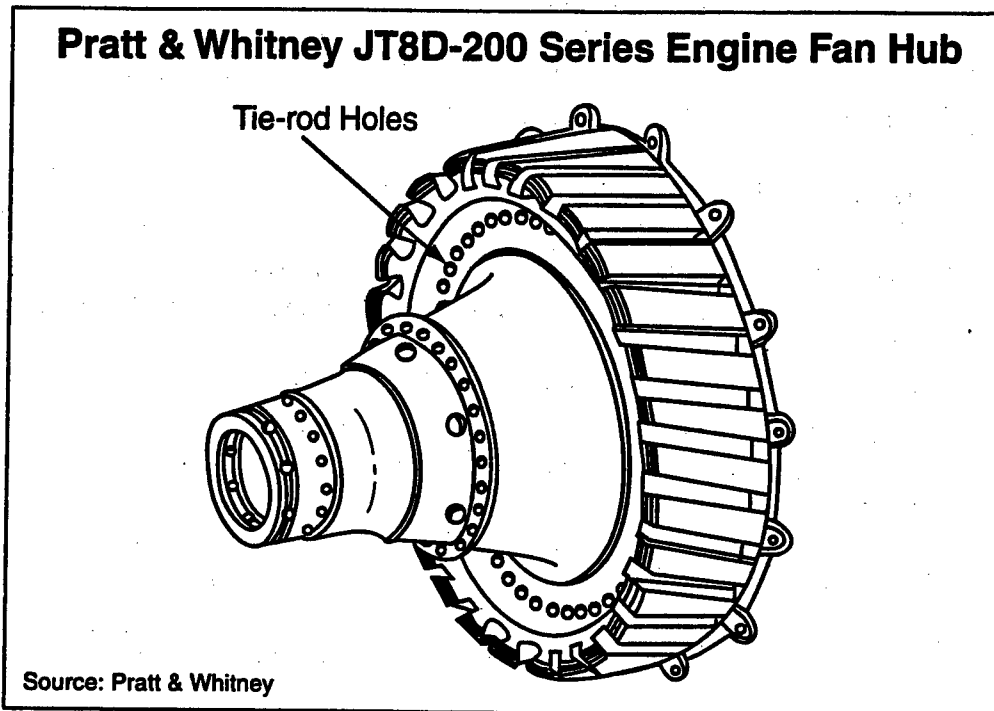

Figure 4.—Pratt & Whitney JT8D-200 series engine fan hub.

(NDT),²⁴ a blade slot dimensional inspection, and blade slot shotpeening²⁵ at Delta's maintenance facility in Atlanta, Georgia. At the time of the accident, the fan hub had accumulated 1,142 cycles since this FPI and visual inspection by Delta on October 27, 1995.

The fan hub assembly was balanced and installed on the accident engine on December 29, 1995, and the engine was operated in a test cell the next day. Engine test log data showed that all vibration parameters were within the manufacturer's limits. The engine was installed on N927DA on January 1, 1996, and operated until the accident with no reported anomalies. N927DA's aircraft logbook contained no pilot reports of engine discrepancies related to the fan hub or reports of airframe vibrations. Between June 6, 1996, and July 5, 1996, the left engine used 54 pints of oil. This quantity of oil was within the engine's normal consumption rate, according to Pratt & Whitney representatives.

1.7 Meteorological Information

The accident occurred in daylight visual meteorological conditions. Pensacola airport weather, reported at 1406 and valid at the time of the accident, was the following:

wind 210 degrees at 12 knots; visibility 7 miles; scattered towering cumulus clouds at 3,500 feet; temperature 32 degrees Celsius; dew point 25 degrees; altimeter 29.98; remarks — towering cumulus reported in all quadrants.

1.8 Aids to Navigation

There were no pertinent issues or problems with navigational aids.

1.9 Communications

There were no known communication problems between the flightcrew and the PNS control tower. The airplane's electrical system was operating normally until the loss of electrical power following the left engine's failure and the severing of the right generator's channel differential protection wires. Loss of electrical power rendered the cockpit radios, the cockpit/cabin interphone, and the PA system inoperative until emergency power was turned on by the flightcrew. Flight attendants in the aft cabin attempted to contact the flightcrew on the interphone without success before the emergency power was turned on. After emergency power was turned on, the first officer used the PA system to advise passengers to remain seated. The

²⁴ NDT methods are those that do not damage or significantly alter the component being tested during the inspection. NDT procedures include visual, FPI, magnetic particle, radiographic, ultrasonic, and eddy current inspections.

²⁵ Shotpeening is a process that bombards metal surfaces with air-propelled shot, or hardened balls. Shotpeening increases the metal's resistance to fatigue cracking.

first officer told Safety Board investigators that he attempted to contact the flight attendants in the rear of the cabin after the emergency power was turned on but that he was not successful.²⁶

1.10 Airport Information

PNS is located about 3 miles northeast of Pensacola, Florida, and has an elevation of 121 feet above mean sea level (msl). The control tower and aircraft rescue and firefighting facilities (ARFF)²⁷ are located on the southwest quadrangle of the airport. The airport is equipped with a low level windshear alert system (LLWAS) and a weather reporting station. Runway 17 is 7,002 feet long and 150 feet wide with a threshold elevation of 171 feet msl. Instrument landing system (ILS), nondirectional beacon (NDB), satellite-based global positioning system (GPS), and radar surveillance approaches are available for runway 17. Standard weather minimums for departures on runway 17 are runway visual range (RVR) 5,000 feet and 1 mile visibility.

1.11 Flight Recorders

N927DA was equipped with a CVR and an FDR.

The FDR was a Lockheed model 209F, SN4131, that recorded 42 parameters, including time, pressure altitude, indicated airspeed, magnetic heading, vertical acceleration, engine data and control surface, and aircraft orientation (pitch and roll). The data indicate that as the airplane began its takeoff roll on runway 17, the engines spooled up to engine EPRs of 1.9 during a 10-second period. At the time of peak thrust, power was lost to the FDR, and recorded data for the flight ceased. The last recorded airspeed was 39.75 knots.

The CVR was a Fairchild model A100, SN 4153. The recording of early cockpit conversations was of fair quality, caused by significant levels of ambient noise in the cockpit. Recordings of later conversations were of good quality after the captain and first officer donned their headset-mounted "hot microphones."²⁸ Three of the four CVR channels contained audio

²⁶On July 10, 1996, 4 days after the accident, Safety Board investigators conducted a test of the accident airplane's PA and interphone systems using emergency power. Both systems were found to function properly.

²⁷The airport ARFF was certificated for Index C level service. Index C pertains to air carrier aircraft of at least 126 feet in length, but less than 159 feet in length. According to 14 CFR Part 139, a minimum of 2 or 3 ARFF vehicles must carry a total quantity of 3,000 gallons of water for foam production.

²⁸The Safety Board ranks the quality of CVR recordings in five categories: excellent, good, fair, poor and unusable. Under the recently revised definitions of these categories, a recording of "fair quality" is one in which the majority of crew conversations are intelligible, but the transcript developed from it may indicate passages in which conversations were unintelligible or fragmented. This type of recording is usually caused by cockpit noise that obscures portions of the voice signals or by a minor electrical or mechanical failure of the CVR system that distorts or obscures the audio information. In a recording of "good quality," most of the crew conversations could be accurately and easily understood, and the transcript developed from it may indicate several words or phrases that were not intelligible. Any loss in the transcript can be attributed to minor technical deficiencies or momentary

information from the cockpit area microphone (CAM), the captain's position, and the first officer's position. The fourth channel contained no information. No structural or fire damage occurred to the CVR unit.

Thirty-one minutes of data (its capacity) were recorded on the CVR, and 19 minutes relevant to the accident were transcribed. The transcript begins while flight 1288 was still at the gate and ends when the left engine failed. (See appendix B.)

1.12 Wreckage and Impact Information

The airplane came to a stop with the left tire of the right main landing gear just to the right of the runway centerline. An oil streak on the runway began about 410 feet from the runway threshold (and about 16 feet left of the runway centerline) and ended under the left engine where the airplane came to a stop. Engine debris was found on both sides of runway 17's centerline along the airplane's path. Several impact gouges were on the runway left of the centerline. The entire left engine nose inlet cowl was found on the runway 563 feet from the runway threshold (see figure 5). The nose bullet was found on the runway about 20 feet to the left of the nose cowl. The front accessory support cover was still attached, and there was no evidence of installation damage.

The fan hub and blade assembly were separated from the left engine, and the surrounding engine outer case and cowl were ruptured with torn and missing sections. The forward part of the stage 1.5 compressor disk was missing. The hub was separated at a 360° circumferential fracture located just forward of the stage 1.5 disk bore. The integral spacer²⁹ had fractured into at least five pieces that were found in the debris field around the airplane. The fan hub fractured into three major pieces, with a smaller fourth piece remaining in the No. 1 bearing assembly. The largest piece, comprising about 2/3 of the hub rim and the adjoining conical section, was found 714 feet to the left of the runway centerline (see figure 6). A prominent scar on the runway and four tandem divots in the ground were aligned in the direction of the location where the piece was found. Another part of the hub rim was found 2,400 feet to the right of the runway centerline in an athletic field. The third major piece of the hub, a triangular-shaped part of the conical section measuring about 11 inches by 10 inches on edge, was found embedded in the right side fuselage interior just above the window at passenger seat row 37.

The fan hub fractured through a tierod hole and blade slot. There were two fan blade roots still in place on the small rim segment and 13 blade roots on the larger rim segment. Three of the 13 blades were full length and bent counterclockwise as viewed from aft looking

dropouts in the recording system, or to a large number of simultaneous cockpit/radio transmissions that obscure each other.

²⁹The integral spacer is the cone-shaped forward part of the stage 1.5 disk and separates the 1.5 disk from the stage 1 disk.



Figure 5.—Left engine nose inlet cowl.



Figure 6.—Two-thirds of hub rim and adjoining conical section.

forward (ALF).³⁰ A smaller fracture surface was found at the forward section of the conical hub oriented at right angles to the hub axis and extending 360° around the part circumference. The hub rim's fracture surfaces were examined at the accident site by a Safety Board metallurgist and were found to have evidence of fatigue cracking.

The outer engine case separated at the C flange (see figure 7).³¹ Forward of the C flange, the case remained attached to the cowl. The case was torn and fragmented in two areas (centered at the 1 o'clock and 7 o'clock positions) between the C and D flanges. The 1 o'clock position was missing a segment from the 12:30 to 2 o'clock positions. The case was intact but had been torn loose from the D flange between the 2 o'clock and 3 o'clock positions. A 14-inch circumferential part of the fan rear case was found on the runway 61 feet to the right of the centerline and 441 feet from the runway threshold. Acoustic honeycomb in the fan case area was ripped, torn, or missing in many places. The splitter fairing³² (see figure 7) was missing from the 1 o'clock to the 7 o'clock position. A torn piece of the splitter remained attached at the 5 o'clock position. Twelve first-stage stator vanes³³ were present on the remaining splitter fairing. The inner diameter ends of the vanes were separated from the inner shroud and bent in the direction of rotation.

Three hub tangs (the retaining walls of the blade dovetail slots on the hub rim) were sheared from the smaller rim segment. One tang was found adjacent to one of the hub fracture sites. Only two tangs were recovered. Thirty-one of the 34 fan blade roots were recovered. There were marks in the front side of several dovetail slots on the hub rim. The fan blades that were on the larger fan hub section showed minor leading edge object damage. The front inner air seal support structure was fractured at two locations and was found still attached to both hub segments. The rotating knife edge seal was separated from the support, and all the rivets had fractured. The blade retention lock ring was recovered from inside the left side of the airplane's fuselage. Twelve fan hub tierods were recovered and appeared uniformly sheared near the bolt heads.

1.13 Medical and Pathological Information

The two passengers who were killed sustained massive head injuries. They were seated on the left side of the airplane in the window and aisle seats of row 37, adjacent to the left engine. One of the two seriously injured passengers sustained head and other injuries from debris. He was seated in the aisle seat of row 37 on the right side of the airplane. The other

³⁰Circumferential positions are described using clock references as seen by an observer viewing the engine or component from the ALF.

³¹Flanges on the outer engine case are strengthening rims that are fastening points for adjoining sections. The C flange joins the aluminum fan front case with the titanium fan rear case just aft of the cowl area.

³²The splitter fairing separates airflow between the fan bypass and engine core.

³³A stator vane is a stationary airfoil positioned between rotating stages of the engine compressor or turbine to direct airflow.

JT8D-200 SERIES ENGINE

ENLARGED PARTIAL VIEW

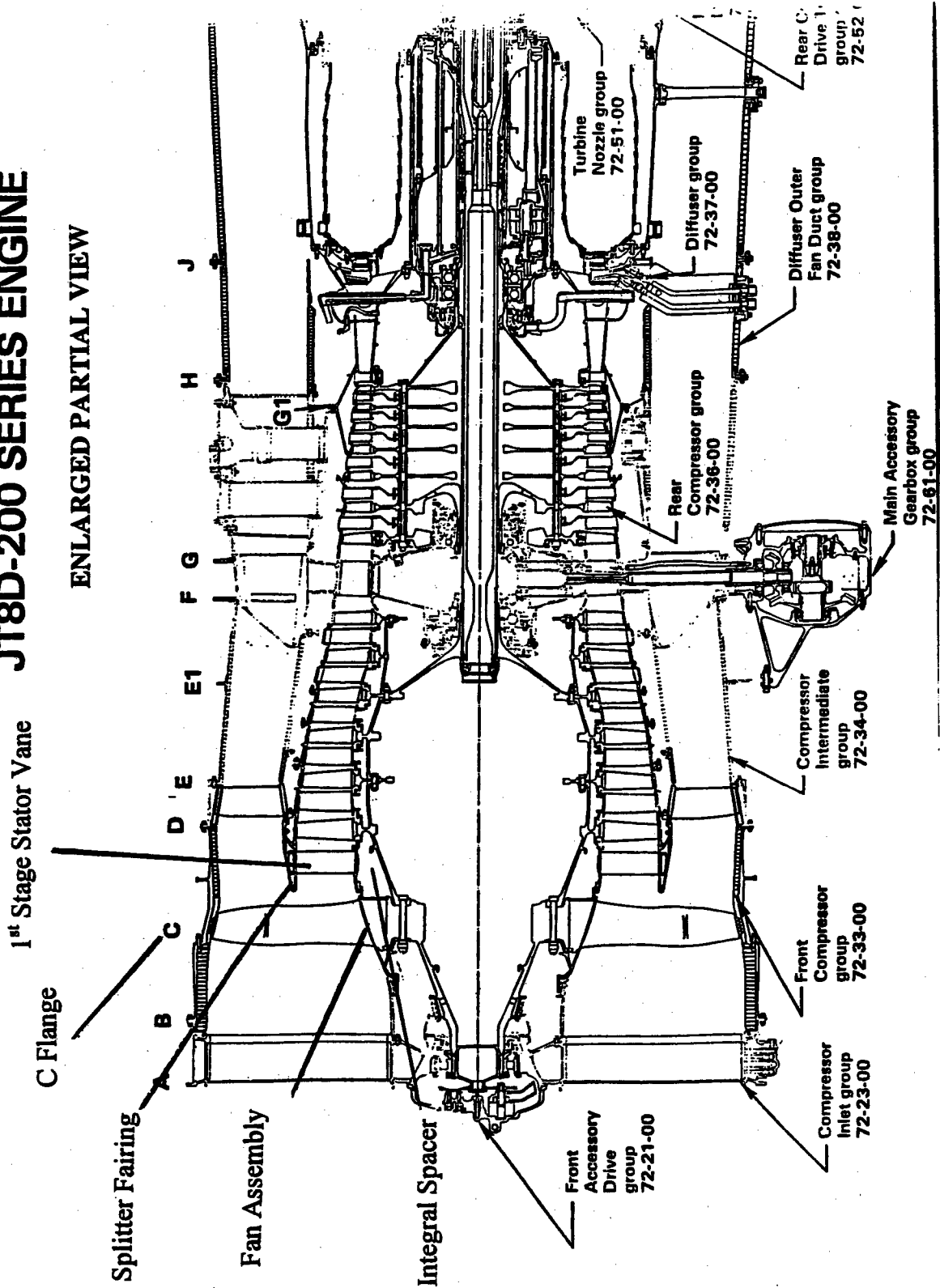

Figure 7.—Enlarged, partial view of outer engine case of JT8D-200 series engine.

seriously injured passenger sustained a fractured ankle when she jumped off the front of the left wing during the evacuation. Three other passengers were slightly injured during the evacuation.

The captain and first officer provided postaccident toxicological samples, which were tested by an independent laboratory and found to be negative for drugs of abuse.³⁴ No tests for ethanol were performed because Delta failed to obtain samples within the 8-hour time limit required by 14 CFR Part 121 Appendix J.

1.14 Fire

A fire erupted in the area of the left engine cowling following the engine failure. According to ground witnesses, the fire was visible for approximately 20 seconds. When firefighters arrived at 1427, they did not see smoke or fire, but one firefighter reported that he smelled smoke. Extinguishing agent was applied to the left engine.

The left engine was disassembled and examined under Safety Board supervision at Delta's technical operations center in Atlanta, Georgia, in July 1996. Safety Board investigators determined that all fire damage to the engine was located from the 6 o'clock to the 9 o'clock positions on the exterior of the cowling. There was no fire damage or evidence of fire on the inside of the upper or lower cowl doors. Based on the amount of soot and blistering found, the lower forward cowl door exhibited the most severe fire damage. Paint had burned off, blistered, discolored, or become grainy from heat in other areas.

No fire occurred inside the cabin.

1.14.1 Emergency Response

The PNS tower controller on duty stated that he alerted crash, fire, and rescue personnel immediately after he heard a loud bang and saw smoke coming from the airplane. Pensacola Fire Department records indicate that the call was received at 1425:09 at the airport firefighting facility.³⁵ At 1427:03, the captain reported serious injuries on the airplane and requested medical assistance. Emergency medical technicians (EMTs), firefighters, and equipment arrived at 1427. Additional medical personnel, firefighters, and equipment arrived from the airport station at 1429. The first officer and firefighters on the ground disconnected the tailcone slide (which had earlier been deployed by the aft flight attendants) and lowered the ventral stairs to evacuate the injured. A medical treatment (triage) area was set up along the side of runway 17, and a landing zone was designated for an emergency medical evacuation helicopter that was used to transport the most seriously injured passenger to a local hospital at 1442.

³⁴The five drugs of abuse tested in postaccident analysis are marijuana, cocaine, opiates, phencyclidine, and amphetamines.

³⁵Times listed in the fire department's log correlated within a few seconds to the times listed in the ATC transcript.

1.15 Survival Aspects

1.15.1 General

The airplane's cabin was configured with a first-class section (rows 1-5) comprising four rows of two seats on the right and three rows of two seats on the left. The coach cabin was configured with double seats on the right and triple seats on the left. (See figure 8.)

As discussed in section 1.1, after the airplane came to a stop following the engine failure, the L-1 flight attendant instructed passengers not to evacuate the airplane, and the first officer made a PA announcement telling passengers not to evacuate.³⁶ The first officer also instructed passengers to remain seated when he walked through the cabin. However, the aft flight attendants had already initiated an evacuation, and about 30 passengers evacuated the airplane using the tailcone and overwing emergency exits. The aft tail cone slide and the L-2 slide were deployed by the flight attendants, and all four overwing exits were opened by passengers. The remaining passengers, primarily those seated forward of the overwing exits, remained on board and exited the airplane using the portable air stairs that arrived approximately 30 minutes after the accident.

1.15.2 The Evacuation

Both the first officer and the aft flight attendants said that they attempted to communicate using the interphone immediately after the engine failure but that they found it inoperative. The first officer attempted to use the interphone again, after emergency power was restored, but received no answer from the flight attendants.

A male passenger, who was seated in an overwing emergency exit row (row 26), told Safety Board investigators that during the takeoff roll he heard a "pop" and that passengers then began unbuckling their seat belts, running, and screaming for him to open the exit. He said that he opened the overwing exit while the airplane was still moving about 30 miles per hour even though he was not certain that this was the proper action to take. He later told investigators that he wished he had been given some guidance for when to open the exit. According to his statement, he stepped out onto the left wing and jumped off the front leading edge after seeing fire coming from the left engine. Other passengers came out of the window exit "frantically," and he said he helped people off the wing until they stopped coming.

The flight attendants assigned to the aft galley and tailcone jumpseat positions indicated that their decision to initiate the evacuation was based on observations of severe damage to the cabin, passenger injuries, and flames from the left engine cowling. According to Delta's flight attendant "In-Flight Service On-Board Manual," dated March 11, 1966, flight

³⁶None of the passengers interviewed by investigators remembered hearing any such PA announcements.

MD-88 CABIN EQUIPMENT LOCATION

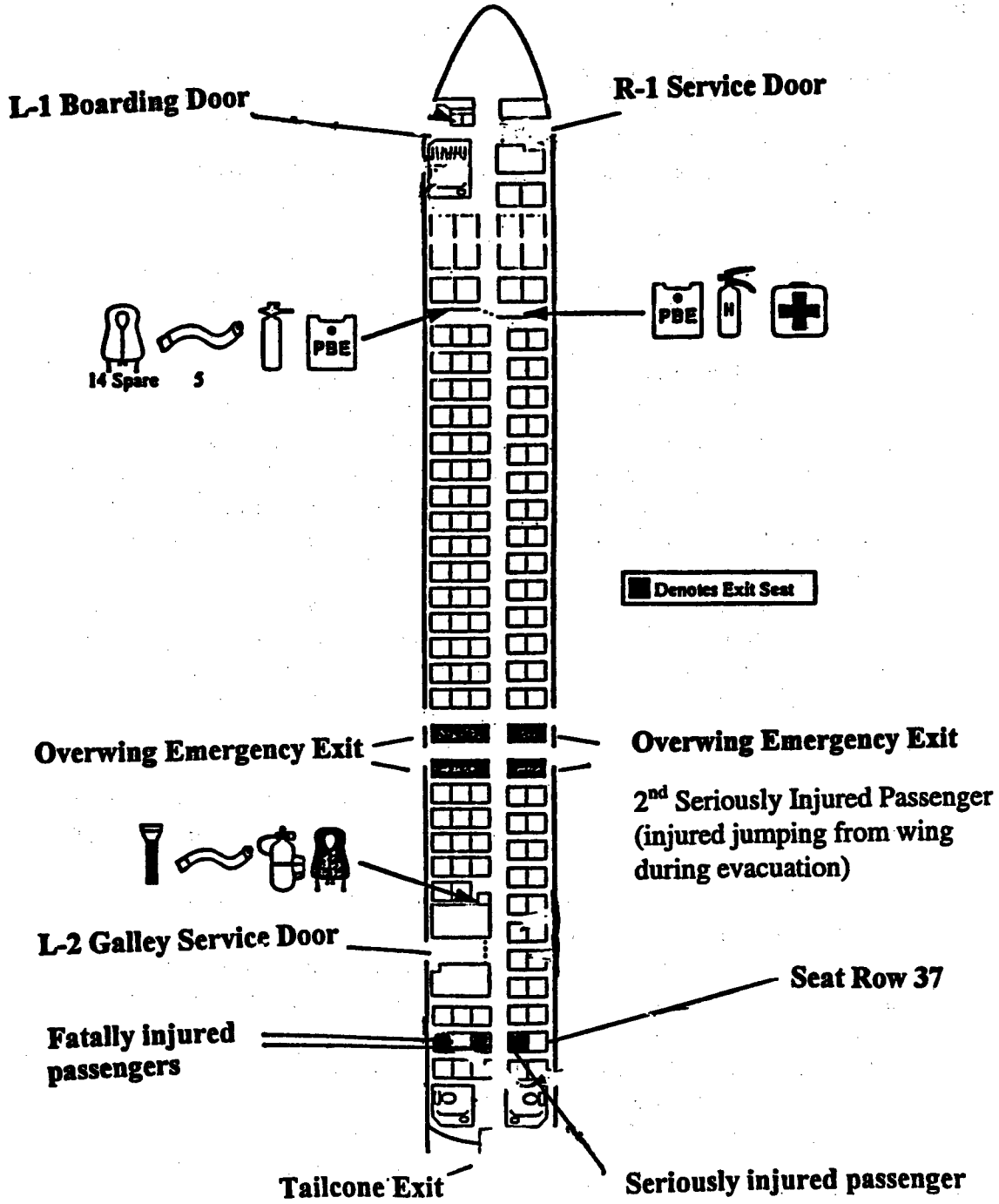

Figure 8.—MD-88 cabin equipment location chart.

attendants "may initiate an evacuation only under the following conditions: severe structural damage, threatening fire or smoke, no response from the cockpit." Emergency evacuations are to be initiated only after the airplane has come to a stop, according to Delta policy.

The Delta flight attendant manual's emergency procedures section also states the following:

Unanticipated Emergency

Call the cockpit crew to coordinate evacuation (be prepared to provide information such as structural damage, fire, etc.)

NOTE: Upon hearing an evacuation horn (L-1011, MD-11), evacuate without further communication from cockpit.

The flight attendant who occupied an aft jumpseat just forward of the L-2 aft galley service door gave the following account of her actions to Safety Board investigators:

The aircraft slowed and as it slowed I...saw debris in the aisle. I tried to call the cockpit [using the interphone] and got no answer. I got off the jumpseat and saw injuries and debris. As I walked into the cabin, I saw head wounds. I went to the [L-2] door and opened it, got a good slide and then saw the fire on the engine. I redirected passengers to go forward.... I saw casualties in the back including a man on the floor, so I could not evacuate out the back.... I tried to help the man on the floor and again tried to call the cockpit. The cabin was full of haze, dust and debris. I assumed [another flight attendant] deployed the tailcone. The passengers initiated the window [overwing exit hatch] evacuation. I ran through the cabin to tell the captain of the serious injuries.... It got very warm on the aircraft.

The flight attendant who occupied the tailcone jumpseat told Safety Board investigators that she also tried to contact the cockpit using the interphone without success.

I saw light coming through the roof, particles near the ceiling but had no difficulty seeing in the cabin. I pulled the handle to deploy the slide in the tail. I told a man to go down the slide and help a lady and a child off the slide. The wife of the injured man got off the aircraft and was screaming. Her husband had fallen into the aisle. [Four passengers] in the back of the aircraft [by the tailcone] got off the aircraft.... It took a long time to get the [portable] stairs to the [L-1] door.

1.15.3 Previous Safety Board Recommendations

In a 1981 special investigation report of the evacuation of 238 passengers from a United Airlines DC-8 airplane on December 29, 1980,³⁷ the Safety Board discussed the difficulties that can result when emergency communications devices are not used or are inoperative. In that accident, a fire in the right landing gear (which was initially erroneously identified as an engine failure) caused the captain to order an evacuation after shutting down the engines. However, because the PA and interphone systems were inoperative, and the megaphones were not used, flight attendants and passengers in the rear of the cabin were not aware that an evacuation had been initiated in the front, resulting in what was described as “an atmosphere of confusion and disorder among passengers and flight personnel.”

In the 1981 special investigation report, the Safety Board noted that some airplanes are equipped with evacuation alarm systems but that such systems are not required by the FAA. The report further noted that in response to a 1972 Safety Board recommendation urging the requirement of self-powered audio and visual evacuation alarm systems, the FAA had “agreed that an independently powered system was needed to initiate evacuations. However, action was not taken [at that time] because the FAA believed that further study was required to determine the most practical and effective means of installing and utilizing such a system.”

As a result of the 1981 special investigation, the Safety Board again recommended, in Safety Recommendation A-81-129, that the FAA “require the installation of an independently powered evacuation alarm system in passenger-carrying aircraft.” However, the FAA did not implement this recommendation. In its December 22, 1981, reply to this recommendation, the FAA stated that the PA system, interphone system, and megaphones are all means of communicating with passengers in the event of an emergency. It further stated that the cost of installing new alarm systems on most aircraft would far outweigh any identifiable safety benefits from having such an alarm system. On June 7, 1982, the Safety Board classified Safety Recommendation A-81-129 “Closed—Unacceptable Action.”

In 1996, the Safety Board again addressed emergency evacuation communications issues in connection with a Tower Air B-747 runway departure.³⁸ In that accident, the flightcrew and flight attendants independently decided not to evacuate the airplane, but because power to the interphone and PA systems had been lost, there was no communication between the flight and cabin crews. Further, information about damage to the airplane and injuries was not relayed by the flight attendants to the flightcrew. The Safety Board report stated, “after an unusual occurrence...positive communications are essential to coordinate the crew’s response, even if the

³⁷ National Transportation Board. 1981. *Evacuation of United Airlines DC-8-61, Sky Harbor International Airport, Phoenix, Arizona, December 29, 1980*. Special Investigation Report NTSB/SIR-81/04. Washington, DC.

³⁸ National Transportation Board. 1996. *Runway Departure During Attempted Takeoff, Tower Air Flight 41, Boeing 747-136, JFK International Airport, New York, December 20, 1995*. Aircraft Accident Report NTSB/AAR-96/04. Washington, DC.

decision is not to evacuate." As a result of that accident, the Safety Board recommended, in Safety Recommendation A-96-157, that the FAA do the following:

Issue a flight standards information bulletin requiring principal operations inspectors of 14 CFR Part 121 air carriers to ensure that their air carriers have adequate procedures for flight attendant communications, including those for coordinating emergency commands to passengers, transmitting information to flightcrews and other flight attendants, and handling postaccident environments in which normal communications systems have been disrupted.

On May 9, 1997, the FAA issued Flight Standards Information Bulletin (FSIB) for Air Transportation 97-07, "Miscellaneous Cabin Safety Training and Procedure Items." The FSIB set forth several evacuation-related policies, including the following:

Title 14 CFR section 121.417 requires crewmember training on emergency equipment, including megaphones. Therefore, when crewmembers receive training conducted as part of this requirement, they should be trained on the location, function, and operation of emergency equipment, including the megaphone. In addition, crewmembers should be trained to follow specified procedures in the event that the Public Address system or the interphone do not work. This is especially important in large airplanes where crewmembers may need to communicate with each other without the aid of the interphone. In addition, Section 121.417 requires training on crew communication and coordination during emergencies. Both emergency training and indoctrination training should include training on individual crewmember responsibilities. The individual responsibilities for flight attendants must be listed in the appropriate parts of the required flight attendant manual. Failure to include a list of the duties and responsibilities of each crewmember could be a violation of section 121.135(b)(2).

The issue of joint training of crewmembers has also been examined by the Safety Board. On August 12, 1992, in a special investigation report,³⁹ the Safety Board recommended in A-92-74 that the FAA do the following:

Amend 14 CFR Part 121.417 to require an evacuation and/or wet ditching drill group exercise during recurrent training. Ensure that all reasonable attempts are made to conduct joint flight crew/flight attendant drills, especially for crewmembers operating on airplanes with two-person cockpit crews.

³⁹National Transportation Board. 1992. *Flight Attendant Training and Performance During Emergency Situations, June 9, 1992*. Special Investigation Report NTSB/SIR-92/02. Washington, DC.

Although the FAA responded that it did not agree with the recommendation, it asked the Aviation Recommendation Advisory Committee's (ARAC) Subcommittee on Training and Qualifications to examine the possibility of improving training in this area. The ARAC was composed of flight attendants, union personnel, airline representatives, and the FAA. The ARAC recommended that airlines be encouraged to have ditching drills and evacuation drills during recurrent training. Based on this, the FAA issued FSIB 95-05, "Emergency Evacuation and Ditching Drills," on February 12, 1995. The bulletin directed that principal operations inspectors (POIs) ensure that their assigned certificate holders are aware of the performance benefits that result when flightcrew and flight attendants perform emergency evacuation and ditching drills together. Additionally, POIs will ensure that if this joint training is not possible, operators should conduct training in which the roles of other crewmembers during emergency evacuations and ditchings are clearly addressed and explained.

On January 23, 1996, the Safety Board classified this safety recommendation "Closed—Unacceptable Action" because the Board continued to believe that group joint exercises during recurrent training were essential to develop and reinforce skills, such as communication and decision-making, needed to work as a team.

The Safety Board has also addressed the need for joint flightcrew and flight attendant CRM training.⁴⁰ The Board recommended in A-92-77 that the FAA do the following:

Require that flight attendants receive crew resource management training that includes group exercises in order to improve crewmember coordination and communication.

The FAA responded that it agreed with the recommendation and that the ARAC subcommittee had been tasked with developing an advisory circular (AC) for guidance for CRM that includes flight attendants. Subsequently, the FAA revised AC 120-51B, "Crew Resource Management Training" to provide information regarding training that includes group exercises to improve crewmember coordination and communications.

The Safety Board's response to the FAA noted that Notice of Proposed Rulemaking 94-35, which was issued on December 13, 1994, proposed to require CRM training for flight attendants and that pending issuance of the final rule, the Board classified this safety recommendation "Open—Acceptable Response."

On March 26, 1996, the FAA informed the Board that it had issued the final rule, "Air Carrier and Commercial Operator Training Programs," to require operators to include CRM training for flight attendants in their FAA-approved training program. The Board replied to the FAA that it had been specifically concerned about the comprehensiveness of air carrier CRM programs. The Board recognized that the FAA's guidance on the scope of a comprehensive

⁴⁰ *ibid.*

CRM program provided to air carriers in AC 120-51 has been updated in recognition of advances in the state of knowledge about CRM and in response to recommendations from the Board to the FAA. The Board further stated that the FAA's timely revisions to the CRM AC (most recently, in AC 120-51B and Change 1 to AC 120-51B) should ensure that air carrier CRM programs are comprehensive. Because of the FAA's adoption of a final rule on mandatory CRM training and the FAA's adequate general definition of a comprehensive CRM program, on July 15, 1996, the Board classified Safety Recommendation A-92-77 "Closed—Acceptable Action." However, based on safety issues previously identified by the Board in its accident investigations, the Board encouraged the FAA to provide additional guidance to air carriers about the importance of group exercises involving both cockpit-cabin coordination and coordination among the individual members of a flight attendant crew.

1.16 Tests and Research

1.16.1 Metallurgical Examination

The fractured components of the accident fan hub were examined in the Safety Board's materials laboratory. The fan hub had fractured radially in two places (see figure 9a). One of the radial fractures contained a fatigue crack that originated at two locations on the inboard side of a tierod hole (see figure 9b). The two origins were located within the tierod hole at distances of 0.307 inch and 0.553 inch from the aft edge of the hole. Fatigue fracture features extended a maximum of about 1.5 inches radially inboard (towards the center of the engine) from the origins (see figure 9c). Outside of the fatigue region, the fracture features were consistent with an overstress separation.

Metallurgical examination of the surface of the hole wall revealed an area in which the surface finish was darker than the surrounding area at each fracture origin. The hole surface in the darker areas showed evidence of circumferential machining marks consistent with marks that would be left by the boring operation performed during the part's manufacture. There was no indication of honing in the darker areas. The remainder of the hole wall surface outside the darkened surface finish areas showed a cross-hatched pattern consistent with marks that would be left by the honing operation performed during the part's manufacture.⁴¹ Magnified examination of the hole wall in the darker areas also showed numerous small parallel surface cracks (ladder cracks) aligned with the longitudinal axis of the hole (see figure 10).

A scanning electron microscope (SEM) examination of the fracture face in the origin areas showed evidence of overstress to a depth of about 0.002 inch adjacent to the hole wall. The overstress fracture region was followed by an area about 0.006 inch deep that contained fracture features consistent with a fast-propagating fatigue crack. From a depth of 0.006 inch to the end of the fatigue region, striations were found consistent with a slower propagating fatigue crack.

⁴¹ According to Volvo, the fan hub's tierod holes are drilled, bored, and then honed during manufacturing.

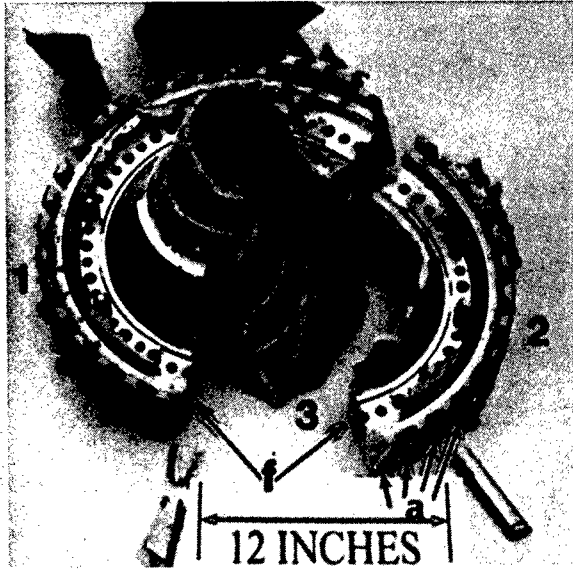

Figure 9a.—Fractured fan hub.



Figure 9b.—View of fatigue crack.

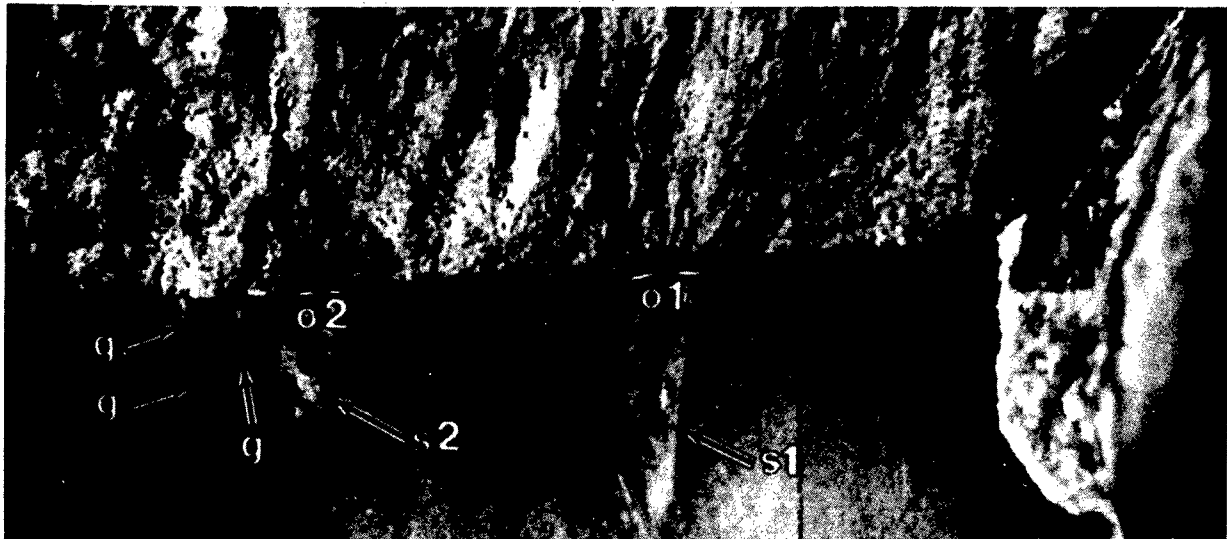
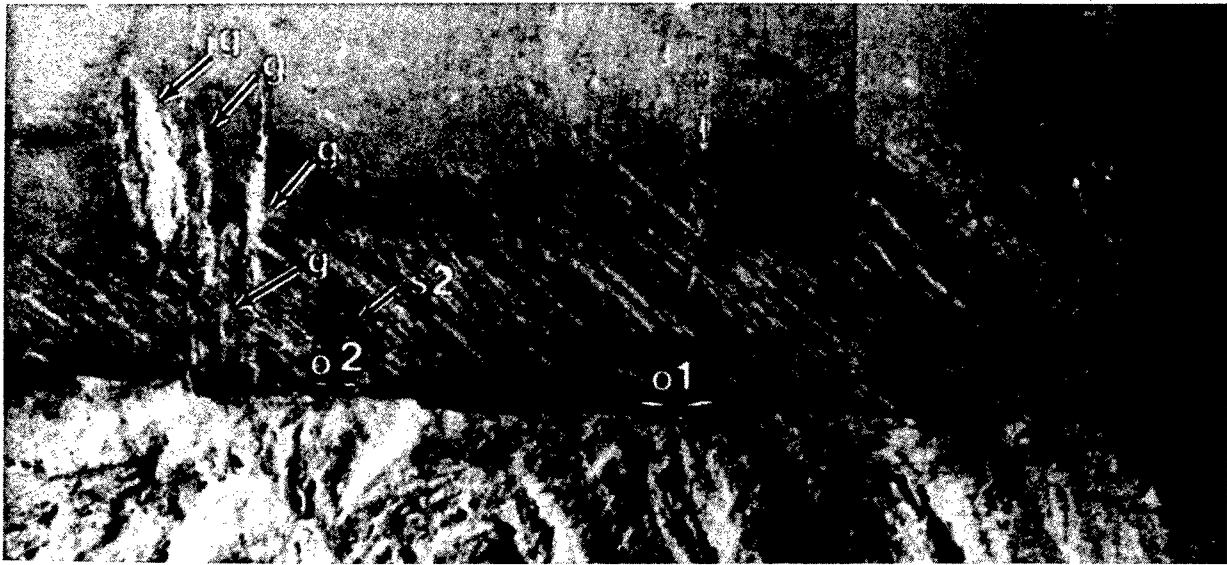

Figure 9c.—Magnified view of fatigue fracture features.

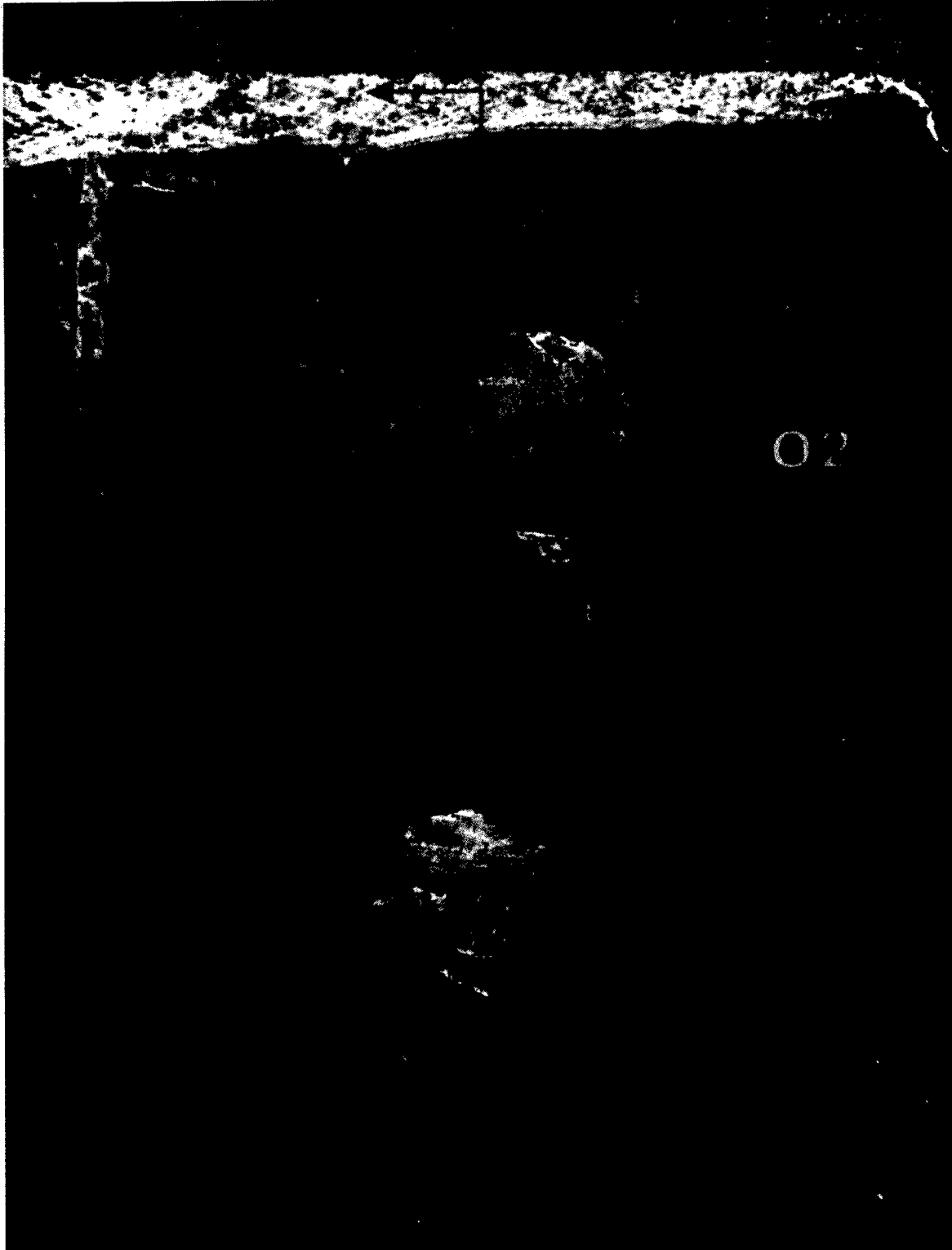

Figure 10.—Magnified view of hole wall.

About 12,887 fatigue striations were found in the fatigue fracture region, roughly equivalent to the number of the hub's flight cycles. A portion of the fatigue fracture surface adjacent to the origin area was discolored slightly darker than other parts of the fatigue region. This discolored fracture region extended about 0.7 inch radially inboard from the origin area. At the aft face of the hub, the fracture discoloration extended about 0.46 inch inboard from the hole. Along the hole wall, this discoloration extended about 0.90 inch forward from the aft inboard corner of the hole. The number of striations in the discolored part of the fracture was approximately the same as the number of flight cycles recorded for the hub at the last FPI performed by Delta.

Metallurgical examination of the cross section of one of the fatigue origins showed three zones of altered microstructure adjacent to the hole wall surface corresponding to the darkened surface finish areas on the hole wall. The microstructural zone closest to the hole wall surface was about 0.002 inch deep (the same as the overstress depth). This zone was heavily layered with recrystallized alpha grains, indicating that the surface temperature had reached at least 1,200°, which is the minimum recrystallization temperature for titanium.⁴² Electron probe x-ray microanalysis conducted by Pratt & Whitney under Safety Board supervision showed that this recrystallized zone contained up to 7 percent oxygen⁴³ and 3.5 percent iron. SEM examination of the altered layer, along with energy dispersive x-ray spectroscopy (EDS) examination, showed a small, elongated, iron-rich particle about 0.0017 inch from the surface. EDS analysis of this particle showed that it contained about 26 percent iron.

The second zone of altered microstructure was from 0.002 inch to 0.006 inch from the wall surface (about 0.004-inch thick). The microstructure in this zone consisted of heavily deformed alpha and beta grains elongated parallel to the surface. Below this area, to a depth of about 0.010 inch from the surface of the hole, was a third zone where the microstructure was distorted in a curved pattern, consistent with the metal having been deformed by bearing pressures from a rotating tool during the manufacturing process.

Hardness of the base material outside the altered microstructure areas ranged between 34 and 36 on the Rockwell C hardness (HRC) scale, which conformed to the material specification requirement of a maximum of 39 HRC, according to Safety Board tests. Hardness tests in the areas of altered microstructure indicated values as high as 52 on the HRC scale.

A section of the fracture face that contained fracture origins was cut from a hub fragment that had not been cleaned to preserve the fracture face in its "as received" condition. The excised section was taken to Evans East Laboratory, a New Jersey contract laboratory, to test for FPI dye penetrant residue on the surface of the part. Delta provided reference samples of FPI fluids used in FPI inspections. A secondary ion mass spectrometry (SIMS) analysis found no

⁴² Recrystallization is a formation of a new grain structure from the structure of deformed metal.

⁴³ At high temperatures, titanium is a highly reactive metal with a strong affinity for oxygen. High temperatures can allow oxygen or nitrogen to be absorbed in the material, forming layers of oxygen- or nitrogen-stabilized alpha.

chemical identification related to the dye penetrant on the hub surface and concluded that "an unambiguous identification could not be made."⁴⁴

The Safety Board also conducted a blue etch anodize (BEA) inspection (see section 1.16.3 for a description of this process) of the fracture section of the accident hub. The inspection revealed a dark blue indication in the darker surface finish areas found in the hole during initial metallurgical examination.

1.16.2 Examination of Volvo's Tierod Hole Drilling Processes

In August 1996, Safety Board investigators conducted an on-site examination of the processes and procedures used by Volvo in Trollhattan, Sweden, to create tierod holes in fan hubs. The tierod holes in the accident hub were created using a four-step process: the hole was drilled, bored in two steps, and then honed. Three tools were used to create tierod holes: a drill, a boring bar, and a hone.

The 24 tierod and SR holes on the accident hub were drilled using a computer-controlled coolant channel drill, which was designed to use coolant streams to flush titanium chips from the hole during a "one-pass" or single-plunge drilling process.⁴⁵

While at Volvo, Safety Board investigators examined a coolant channel drill of the type used on the accident hub and determined that it was a conventional pattern twist drill with tungsten carbide cutting-edge inserts. The 12.2-mm (.480-inch) drill had an internal conduit for coolant to flow down the drill core to enter the hole (being drilled) behind two carbide cutting edges. The coolant served as a lubricant and flushing agent to remove chips from the hole. Volvo employees stated that the flushing was important because titanium chips can be easily compacted in hole-drill interface areas, and this can cause friction and elevated temperatures in holes.

Subsequent to the drilling operation (which drills the hole to a .480-inch diameter), the hole was enlarged by a boring operation. The first boring step enlarged the hole to .508-inch diameter, using the same type of spindle that held the drill. A second boring step enlarged the hole to .516 inch. The holes were then finished on a second machine that uses a boron nitride hone with a lubricant or honing oil, resulting in a finished diameter of .5175 inch.

⁴⁴Delta used a "Class 1" high sensitivity dye penetrant for the accident hub's FPI. Unlike "Class 2" ultra high-sensitivity dye penetrant currently in use at Delta, Class 1 penetrant does not contain phosphate ester or any other uniquely identifiable chemical that would have remained on the fracture surface from the FPI.

⁴⁵A coolant channel drill has two internal borings that bring coolant/lubricant to the tip of the drill just behind the cutting lips. The tip of the drill is made of tungsten carbide. Tungsten carbide drill tips are used to extend the time between drill tip sharpening. Although the coolant channel drill was the focus of initial fan hub inspections following the accident, a standard drill has been linked to a hub fracture on a Pan American Airways B-727. (See sections 1.18.6 and 2.5.) Volvo determined that the coolant channel drill was causing dimensional nonconformities in holes and switched to a high-speed steel drill shortly after the accident hub was manufactured.

The difference between the diameter of the drill and the finished hole was about .0375 inch. The total radial depth of the material removed after drilling was about .0185 inch.

Pratt & Whitney records indicated that the company approved Volvo's request to use the coolant channel drill (rather than a standard drill that is removed periodically during drilling to clear chips from the hole) on February 11, 1988. The Pratt & Whitney "Process Approval Record" noted that the request was characterized as an "insignificant change." The change was approved because changes in drilling operations were classified as "insignificant" by Pratt & Whitney because subsequent material removal (in the boring and honing phases) was accomplished to a depth of at least .010 inch.⁴⁶

Pratt & Whitney's design and manufacturing specifications were approved and monitored by the FAA. Volvo was required to receive Pratt & Whitney approval for process changes to these approved procedures. Following the accident, the FAA conducted a "special quality system audit" at Pratt & Whitney from July 29 through August 2, 1996. Volvo was last audited in 1992. The special audit noted that Pratt & Whitney's "Engineering Source Approval" requires that a process approval record be issued for "significant changes." The FAA audit report noted that "significant changes include new tooling, sequence of operations, a change in any process which could result in cracking, or location within a plant." Noting Volvo's request for the drill change, the FAA audit stated that "several process approval records were observed in which tooling was changed and/or operation sequence [and that] these approvals were classified as insignificant." Pratt & Whitney has since changed this procedure and now requires that all changes related to hole drilling be considered "significant" and reviewed according to requirements for that category of change.

1.16.3 Review of Fan Hub Inspection Procedures Following Manufacture

According to Volvo and Pratt & Whitney documentation, completed hubs, including the accident hub, were subjected to several postmanufacturing inspections while at Volvo, including dimensional and visual inspections, and FPI and BEA inspection procedures.⁴⁷ The dimensional inspection checks the location, concentricity, diameter, and perpendicularity of holes. The visual inspection is to examine the surface finish and look for evidence of residual machine marks. The FPI checks the surface of the material for physical defects such as cracks, voids, or metal porosity. The BEA inspection process, which is unique to titanium, involves a visual inspection of the surface after it is anodized (the part surface is electro-chemically

⁴⁶The manager of Pratt & Whitney's materials control laboratory testified at the Safety Board's public hearing that "our history of machining of titanium holes...indicated that if you were going to remove greater than ten thousandths in subsequent operations, the initial operations—particularly drilling in this case, that anything caused by the drilling operation would be removed."

⁴⁷Pratt & Whitney's quality control system, which includes NDT standards, is also accepted by the FAA, according to testimony by an FAA principal aviation safety inspector for manufacturing during the Safety Board's public hearing in Atlanta, Georgia, March 26-28, 1997. The inspector stated, "What [the FAA does] is approve the methodology or the methods that they do in order to approve these systems or changes...The FAA does not individually approve each [NDT] method."

oxidized) for anomalies associated with microstructure changes in the metal. The BEA process was developed by Pratt & Whitney in 1971 to detect defects such as alpha and beta segregation, excessive grain growth, forging laps, and beta flecks.⁴⁸

According to Pratt & Whitney, the BEA process can be applied to all rotor-grade titanium alloys. The BEA process, which is performed after all machine work is completed, includes three steps: etching⁴⁹ in an acid/salt solution to clean the surface, anodizing in a tri-sodium phosphate solution, and etching again in a nitric/hydrofluoric acid solution. The anodizing step produces a dark blue oxide coating on the part. The etching in the nitric/hydrofluoric acid solution removes some of the blue surface coloration, creating a contrast between anomalies and the normal surface indication (the amount of coloration removed differs between anomalies and the normal surface). Before the accident, Pratt & Whitney provided BEA inspectors with six color pictures of rejectable defects, referred to as templates, to help identify anomalies.⁵⁰ These anomalies have been shown to develop unique patterns or visual signatures. Following the accident, Pratt & Whitney developed four additional templates to help identify microstructural anomalies similar to that which existed in the accident hub. According to Pratt & Whitney, the new templates depict "localized area[s] of work hardening⁵¹ as exhibited by variation of color," a "localized area of work hardening and iron contamination exhibited in appearance throughout [the] entire length of the hole," and a "properly machined hole exhibiting uniform color and appearance." All of the templates are contained in Pratt & Whitney's proprietary Etch Inspection Standard, EIS-13, "Blue Etch Anodize: Disks, Hubs, Couplings, Blade Retainers, Rotating Airseals and Rotating Spacers."

Fan hubs that pass the BEA inspection are subjected to a visual inspection. Pratt & Whitney Visual Inspection Standard [VIS] 454 applies to holes, including the bolt hole, providing "acceptance limits for surface imperfections on major rotating parts." According to VIS 454, bolt holes were allowed to have "burnish marks" up to .125 inch around the hole's opening on the hub surface. The marks are described as a "shiny area resulting from rubbing against a hard smooth surface; may contain scratches of no apparent depth." VIS 454 does not describe acceptable damage to the hole's interior walls.

⁴⁸ Alloy segregation refers to the separation of alpha and beta grains into separate groups instead of being mixed homogeneously throughout the alloy. Forging laps are defects that form whenever metal folds over itself during die forging. Beta flecks are defects consisting of beta stabilizer element segregation during solidification of ingots.

⁴⁹ Etching is a process that treats the surface of a part to expose or exaggerate the surface conditions of the metal.

⁵⁰ The Pratt & Whitney templates included depictions of the following: "lap" [forging], "segregation," two overheat conditions, "course structure," and "grain flow patterns."

⁵¹ According to the "Metals Handbook," published by the American Society of Metals, work hardening, also known as strain hardening, is defined as an "increase in hardness and strength caused by plastic deformation at temperatures lower than the recrystallization range." This term has been used to describe the anomaly in the accident hub. However, the defect was later determined to be a layer of oxygen-stabilized alpha created by heating greater than that necessary to create a work-hardened layer.

A May 26, 1989, Volvo document stated that the accident fan hub had two nonconformance notations, or imperfections, as it progressed through the manufacturing process.⁵² Following the drilling process, according to Volvo fan hub manufacturing documents, the drill operator noted, "two holes [at the] 12.117 [location] are +0.035 and one hole at 13.095 [location] is 0.08, some chatter marks in two holes applies to serial number R32971 [the accident hub]." Volvo documents indicated that these "chatter marks" were no longer noted after subsequent boring and honing operations. Later, the BEA inspector noted during his inspection of the accident hub, "R32971 has manufacturing marks in hole 13.145 mm, 180 degrees relative to S/N marking."⁵³ The hole described by the BEA inspector referred to the same tierod hole analyzed by the Safety Board after the accident. There was no further description in Volvo's manufacturing records of the accident hub "manufacturing marks" or where they were located in the hole. Volvo visual inspection and supervisory personnel subsequently determined that the fan hub met Pratt & Whitney's manufacturing criteria, and the component was sent to Pratt & Whitney for installation.

In testimony during the Safety Board's public hearing, a Volvo fan hub quality manager testified that the BEA inspector who made the notation did so to alert the visual inspector to the surface condition. According to the Volvo manager, the indication did not match any of the templates used by Volvo to identify anomalies at the time and "was not a blue etch indication. [It was] an observation he made on the surface." There was no notation of a BEA indication of a defect in Volvo manufacturing records relating to the accident hub.

A representative of Pratt & Whitney's Safety Department told Safety Board investigators that the company did not perform, nor was it required to perform, a detailed inspection of fan hubs received from Volvo, describing the acceptance procedure as a general receiving inspection that involves checking for shipping damage and verifying part numbers. NDT testing was not performed by Pratt & Whitney on newly received fan hubs.

In a July 19, 1996, letter to the Safety Board, Pratt & Whitney representatives wrote that the company "brought [Volvo] on board as a vendor of these hubs in 1984, at which time they became a partner with Pratt & Whitney in the JT8D program." The letter continued, "The quality assurance core group conducts a full systems audit on the average of every four years. The vendor's quality system, manufacturing and process, gauge calibration, processing of nonconforming material, nondestructive testing, product, etc. is audited. Volvo was audited in 1992 and August 1996. In both audits, no significant items were found."

⁵² A notation of nonconformance is used on a shop traveler (a process sheet that documents inspections or tasks performed on a component) to indicate that a part did not meet an inspection standard. The deficiency must be corrected before being signed off.

⁵³ The BEA inspector's remarks were written in Swedish and translated by the Swedish Board of Accident Investigation at the Safety Board's request. Translations were also made by two Volvo employees. One employee used "machining marks" to describe the BEA inspector's remark, and another translated the remark as "abrasive marks."

1.16.4 Followup Drilling Tests Conducted by Volvo

According to Volvo, it conducted more than 300 test drillings following the accident in an attempt to duplicate the microstructural defect found in the accident hub. In a summary report of its test drillings, Volvo stated that drilling was conducted in some of the holes without coolant and at higher-than-prescribed drill revolution and feed speeds, to cause drill breakage or breakdown, and the accumulation of chips in the tierod hole. "Drill tests have shown that overheated/work hardened microstructure can be created during rough drilling, but not during subsequent boring and honing operations," the Volvo report stated.⁵⁴

The Volvo report listed eight holes that had been test drilled without coolant to drill breakage or breakdown, of which seven holes were drilled with a high-speed steel drill and one hole with a carbide drill. Two holes were found to have altered microstructure, and one, produced by a high-speed steel drill, was similar to that found on the accident hub. According to Volvo, the other test holes showed no relevant abnormalities. The report stated that "to get defective microstructure, high local heat in combination with heavy deformation is required. This can be achieved by accumulation of chips. All damage in the holes [was] created [by] rough drilling...performed by forced tool breakage and by forced accumulation of chips."

The report stated, "The area quite close to the location of the drill breakdown [in the hole drilled by the high-speed drill and identified as hole #2B]) shows a microstructure, in the surface layer, with an appearance similar to the failed hub. The microstructure...is heavily deformed and [had] a hardness of up to 53 HRC, which corresponds well with the values for the failed hub...The generated surface layer is very brittle and contains several cracks."⁵⁵ Chemical analysis shows that the surface layer contains a high concentration of iron from the drilling operation."

1.17 Organizational and Management Information

Delta Air Lines had an international route structure and employed about 68,000 people at the time of the accident. The airline operated 536 aircraft with more than 2,700 flights a day to 153 domestic and 51 foreign destinations. The fleet comprised 52 Lockheed L-1011s, 58 B-767s, 86 B-757s, 67 B-737s, 129 B-727s, 12 MD-11s, 12 MD-90s, and 120 MD-88s. Delta has operated MD-88s since December 30, 1987.

According to Delta, 11 inspectors were employed in the FPI shop. The inspectors were supervised by a shop foreman, who reported to the manager of powerplant quality

⁵⁴The boring and honing processes, which do not remove as much material from the hole as the drilling process, do not create enough heat to reach the titanium transformation and recrystallization temperature.

⁵⁵These cracks appeared similar to the ladder cracking found in the accident hub by the Safety Board during metallurgical examination.

assurance. The manager of powerplant quality assurance reported to the director of quality assurance, who reported to the senior vice president for technical operations.

1.18 Additional Information

1.18.1 Fan Hub Cleaning and FPI Preparation Processes Used by Delta

As a "safe life" or "life-limited" part, the fan hub was certified by the FAA, based on Pratt & Whitney engineering data, to operate safely for its total design life (20,000 cycles) in the engine and did not have to be inspected if it was not removed from the engine. FPI and visual inspections were conducted on fan hubs at the Delta overhaul facility only if they were removed during engine overhaul or disassembly.

The Delta senior vice president for technical operations, which included engine and component maintenance, testified during the Safety Board's public hearing that with a "safe life" part "it is assumed from the beginning that the part is defect-free [on delivery]. And if it's defect-free, then we establish certain inspection requirements that are intended to find normal wear and tear and abuse and various things of that nature."

The Delta senior vice president added, "FPI may not be the appropriate technique to use to evaluate...pre-existing damage. We may have to use eddy current...[or] ultrasonic⁵⁶...that will give you an enhanced opportunity, because the condition for safe life...is that this part will operate throughout its life, even without an inspection."⁵⁷

Fan hub FPIs were conducted in accordance with Pratt & Whitney's Overhaul Standard Practices Manual (OSPM) inspection procedures and Delta standards, both of which were accepted by the FAA.⁵⁸ Delta's FPI process was observed by Safety Board investigators

⁵⁶ According to the Metals Handbook, published by the American Society of Metals, ultrasonic testing is an NDT method in which high-frequency sound waves are introduced to materials to detect surface and subsurface flaws. Sound waves lose energy, or attenuate, when they travel through material. The reflected beam is displayed and analyzed to detect the location of flaws or discontinuities. Eddy current inspections measure fluctuations in an alternating magnetic field around a part generated by a transducer carrying an alternating current. Eddy current inspections are used to locate surface and near-surface defects.

⁵⁷ Although FPI is the industry-accepted method to inspect fan hubs after they are in service for cracks and other anomalies, eddy current inspections are now conducted by Delta and other airlines to augment FPIs.

⁵⁸ According to 14 CFR Part 33.4, Pratt & Whitney and other type certificate holders for aircraft engines must provide "Instructions for Continued Airworthiness" to operators. Appendix A to Part 33 specifies that these instructions must include "scheduling information for each part of the engine that provides the recommended periods at which it should be cleaned, inspected, adjusted, tested, and lubricated, and the degree of inspection, the applicable wear tolerances, and work recommended at these periods." Pratt & Whitney's JT8D Engine Manual defines the "minimum requirements that Pratt & Whitney engines must comply with to ensure the continued airworthiness of the engine." It states that "all performed cleaning, disassembly, assembly, inspection, repair, modification, test, storage, preservation and other tasks must adhere to the requirements defined in this manual and in supporting FAA-accepted documents such as Illustrated Parts Catalogs, Standard Practices Manual, and Service Bulletins."

after the accident. It involved three phases: cleaning, FPI processing (dye penetrant application, emulsification, drying and development), and FPI inspection.

1.18.1.1 Cleaning

After being removed from an engine and taken to the cleaning shop, the fan hub that was used to demonstrate the FPI process to Safety Board investigators at Delta was placed on a suspension rack equipped with a rubber mesh mat. It was then placed in a vat containing a degreaser cleaning solvent for about 30 minutes and then given a "cold" rinse in circulating water. After the cold rinse, the fan hub was soaked in a soap and water mixture in another vat for about 10 minutes and then rinsed again. The hub was then soaked in a vat of graphite stripper. Delta maintenance personnel indicated that parts can be soaked in the graphite stripper for up to 4 hours.

The hub was then rinsed in hot water. According to the "Fluorescent Penetrant Inspection" section of Pratt & Whitney's OSPM, dated May 15, 1995, parts that have been cleaned "must be dry and at room temperature before...penetrant [application]." The OSPM, in another section titled "Cleaning Process," dated November 15, 1995, states, "Put part fully in hot water at 150 to 200 degrees Fahrenheit until the temperature of the part is at the water temperature to flash dry."⁵⁹ The Safety Board investigation revealed that another major engine manufacturer requires that life-limited parts be oven dried before penetrant is applied.

Delta's Process Standard 900-6-3,⁶⁰ "Inspection-Fluorescent Penetrant," does not list part drying in its section on surface preparation. However, Delta Process Standard 900-1-1 No. 18, "Paint Stripping, Dry Film Lubricant and Carbon Removal - Tank Method," dated June 15, 1996, for aircraft and engine parts states, "Immerse in a hot water (150-200 degrees F) rinse tank until part equals the temperature of the tank. This will allow for flash drying of most parts upon removal." The process standard states that after the part is removed from the hot rinse, "clean, dry compressed air or vacuum can be used to remove trapped water if necessary."

A Delta representative said operators determined when the hub reached the same temperature as the water by "feel" and that before the accident no criteria were used to determine the tank's water temperature other than a weekly check using a thermometer. After the accident, Delta changed this procedure to require daily temperature checks.

Delta's director of compliance and quality assurance, whose division included the cleaning and FPI departments, testified during the Safety Board's public hearing that flash drying "should be immediate." He stated that limitations of the flash drying process included

⁵⁹Flash drying is a drying method that relies on the part's temperature being equal to the hot water tank's water temperature to quickly evaporate water from its surface.

⁶⁰A process standard at Delta is a written set of procedures for accomplishing FPIs and other maintenance tasks accomplished by the airline.

“entrapment of water into areas that you can’t readily see or flaws, or in some cases...a manufacturing defect.”

The director for technical services for a company that provides chemicals for the FPI process testified at the Safety Board’s public hearing that the effectiveness of flash drying is “going to depend on the crack. If it’s a very shallow tool mark...a scratch, it [flash drying] may do very well. If it’s a fairly deep fatigue crack, which is what this particular situation is, it’s doubtful whether you’re going to remove that [water] from a fatigue crack. And it’s going to depend on the depth of that crack. The deeper the crack, the worse the case.”

The general manager and director of technical services for a company that provided hardware for FPIs testified in the public hearing that for an FPI to be successful “it’s not only critical, it’s absolutely imperative that the parts come to the process clean and dry. That means free from grit, grime, oils, dirt, water, you name it.” He noted that after the hot rinse “we will without fail recommend the use of some dryer, some hot forced air dryer...Penetrant is basically an oil. And if there is water in the defect, then the water will repel that penetrant and make it difficult if not impossible for [penetrant] entry to occur.” He added, “If you’ve got water in a defect, a lot of it, penetrant won’t get in...And you’ll also impede your ability to determine the depth of the crack.”

1.18.1.2 Dye/Developer Application

After flash drying, the fan hub was subjected to plastic bead [media] blasting⁶¹ and soaked in dye penetrant for about 30 minutes. A Delta FPI inspector stated that the dye’s quality was checked daily. The hub was spray rinsed with water after being removed from the dye vat and then placed into an emulsifier⁶² for up to 90 seconds. The hub was spray rinsed again and placed in a drying oven for about 10 minutes at 160°F. After the fan hub was removed from the dryer, dry developer powder⁶³ was sprayed on using a spray gun. During the demonstration, investigators observed that the developer dust adhered to the external surface areas of the hub, but did not cover the entire depth of the holes in the hub.⁶⁴

⁶¹Plastic bead blasting, also referred to as media blasting, is designed to eliminate antigalling compound or oil remaining on the hub after its final wash. According to Delta’s Process Standard 900-1-1, No. 21, “dry plastic media abrasive can be used for removal of heat scale, carbon deposits, corrosion, and rust and for stripping paint in preparation for repainting on steel or titanium parts.”

⁶²The emulsifier is a liquid agent that must be applied to the nonwater-washable dye penetrant to allow water rinsing.

⁶³Developer powder, or dust, is a powder that draws penetrant from a surface crack or defect to make the defect visible under natural, artificial, or black light (as a bright fluorescent green indication against a dark purple indication).

⁶⁴During the investigation Delta augmented its developer-application technique by adding the use of developer-filled squeeze bulbs to direct developer powder into the holes.

Delta's FPI process standard states that parts must be inspected within 2 hours after application of the developer dust and that indications found more than an hour after application of the developer are to be considered suspected false positives. According to the process standard, if the inspection does not occur within 2 hours, the component should be returned and the entire preparation process repeated.

When indications are found, developer is reapplied in a procedure known as "bleed out."⁶⁵ According to this procedure, inspectors are to wait at least 5 minutes to confirm that an indication had not reappeared after developer was reapplied. Safety Board observers found that Delta had no formal logging procedures to record when parts received had developer dust application, and how long parts had been ready for inspection. Delta representatives said personnel working the line had "group knowledge" of these times.

1.18.1.3 Inspection

Two FPI inspections by two different inspectors were witnessed at Delta's FPI shop by Safety Board investigators after the accident. They were conducted similarly, with only slight variation in inspector techniques. The inspection area, referred to as a "tent" by the inspectors, had heavy canvas walls. Parts to be inspected were placed on plastic rollers that allowed them to be moved more easily into the tent. Parts were moved by hand. Both inspectors used a magnifying glass to inspect suspect areas identified in the FPI. The inspectors also used mirrors during the FPI process.

The Delta FPI inspector who examined the accident hub on October 27, 1995, testified during the Safety Board's public hearing that he did not recall specifically inspecting the accident hub and stated that he did not recall ever finding a crack on a -219 series hub.⁶⁶ He outlined the inspection procedure he used, "Normally, when I bring a part into the tent...I would use a white light and inspect the outside diameter of the hub, looking for any noticeable defects. I would then index the hub [marking a reference point] and use the black light and inspect at 360 degrees. I would then turn the hub on its side, and I would inspect the inside."⁶⁷

The inspector testified that the FPI inspection tent was equipped with two black lights, one attached overhead and one that is handheld. Referring to inspection of the holes, the inspector testified that he tilted "the hub on its side and just [looked] in the holes with the black light. It's not a very good inspection technique for that....You have holes that are 3 inches in

⁶⁵Bleed out occurs when the dye penetrant is drawn out of surface cracks through the action of the developer powder.

⁶⁶Delta representatives told Safety Board investigators that no cracks had been detected on -219 hubs before the accident.

⁶⁷Neither inspector marked or indexed hubs when Safety Board investigators observed the FPIs at Delta after the accident. However, the inspectors stated that they used "natural marks" [tags or serial numbers] on the hubs as reference points.

length, and it's very difficult to see in there....It's very difficult to do a complete 360 degree inspection of these 3-inch holes."

According to the inspector, FPI inspections of -219 fan hubs can take between "40 minutes to an hour and a half to two hours. It depends on what you find." He described the FPI inspection process as "tedious. It's monotonous."

After the accident, Delta developed FPI technique sheets to provide additional guidance to their inspectors. The technique sheets, located in a binder outside the inspection booth, contain part-specific information about the rejection criteria, critical areas, the importance of marking a reference point, recommended inspection aids such as hoists and mirrors, and steps for completing the inspection of the part.⁶⁸

1.18.2 FPI Inspector Training at Delta

According to Delta, its FPI inspectors were trained in accordance with the Air Transport Association of America's (ATA) Specification 105,⁶⁹ "Guidelines for Training and Qualifying Personnel in Nondestructive Testing Methods." The FPI inspector conducted the FPI on the accident fan hub when he was a Level I inspector, according to company records. He told Safety Board investigators in July 1996 that he had been performing FPIs for about 18 months after completing his training and that he had been performing FPIs for about 11 months at the time that he inspected the accident hub. He was a Level II inspector when he was interviewed by Safety Board investigators.

According to ATA Specification 105, which was adopted by Delta, Level I inspectors are required to complete 20 hours of classroom instruction, 80 hours of on-the-job training from a more experienced Level II instructor/inspector, and pass written and practical examinations.⁷⁰ Level I inspectors are qualified to conduct inspections, make accept/reject determinations, and document the results. Level II inspectors complete 480 hours of on-the-job training and are qualified to provide training to new inspectors. After an August 1996 FAA technical review of Delta's FPI program (see section 1.18.4 for details of this review), Delta added 12 hours of classroom instruction and written and practical examinations to Level II training requirements.

⁶⁸ According to a recent study, "Reliability Assessment at Airline Inspection Facilities, Volume III: Results of an Eddy Current Inspection Reliability Experiment, May 1995, Final Report," some inspectors failed to detect defects because they did not resume their inspection at the appropriate location after stopping to move equipment.

⁶⁹ ATA Specification 105 was issued in 1990 after NDT specialists from ATA member airlines recommended development of a uniform approach to training. ATA 105 was derived using military standards (MIL-STD-410) with additional focus on airplane inspection. It provides guidance for inspector qualification, but inspector certification is established by individual operators.

⁷⁰ Inspectors at Delta were merit selected using a bid process and peer review. Satisfactory performance in previous positions at the airline was considered before an individual was selected.

Before the accident, Delta required inspectors to be recertified at least every 3 years by either demonstrating continued satisfactory performance or by passing a requalification examination. During the FAA's August 1996 postaccident review of Delta's FPI facility, it was determined that the primary method for recertification used at Delta was evidence of continuing satisfactory performance. The FAA's inspection team recommended that written and proficiency examinations be required during inspector recertification. Delta responded to the recommendation by requiring that inspectors score 80 percent on a written examination containing 25 multiple choice questions on the FPI process and procedures, and receive training to proficiency on a practical examination that required the inspection of about 10 pieces including test panels, small parts with and without defects, and dirty parts. Delta also asked the FAA to communicate its recommendation to the industry for revision to ATA Specification 105, which Delta had been following. Requalification guidelines in Specification 105 state that inspectors who have been active in a 6-month period and have demonstrated satisfactory performance should "be evaluated for compliance with performance standards, by a level III or other designated individual, at an interval not to exceed three (3) years."

According to Delta records, inspectors are also tested for near vision and color blindness by Delta's medical department. Delta records indicated that the accident hub inspector was in good health, was assigned regular work hours, and had passed vision examinations 3 months before he inspected the accident hub.

1.18.3 FAA Oversight and Review of Delta's FPI Process

During the Safety Board's public hearing, the FAA principal maintenance inspector (PMI) assigned to Delta testified that FAA inspectors assigned to Delta "had no formal training in FPI." He stated that FAA inspectors formally inspected the FPI line "a couple of times a year. Informally they were there more often than that. Oftentimes, folks would be at Delta doing one thing and decide to just walk over and glance at what's going on in an area. That isn't considered a formal surveillance."

The PMI added, "We go into the operator's facility and we'll look at their process. What are they going to do. And we follow whatever inspection they're doing or whatever maintenance process they're applying to any component or part or aircraft, and ensure that they follow their procedures. If we have a question about where those procedures generated from, did they incorporate the manufacturer's recommendations, did they get the manufacturer's approval to deviate in certain cases. Then we'll ask them to provide us that documentation, and we'll ask them to take us through their engineering analysis." The PMI testified that inspectors expect operators to "follow the manufacturers' manuals" and that changes had to be coordinated with the manufacturer.

Following the accident, on August 13 and 14, 1996, the FAA conducted a technical review of Delta's FPI process at its Atlanta, Georgia, maintenance facility. The technical review team comprised representatives from the FAA's Flight Standards Division and

Aircraft Certification Service, and an FAA aviation safety inspector from the Atlanta Flight Standards Certificate Management Office for Delta.

The findings of the FAA review included

1. There is no assurance that the material received by the nondestructive inspection organization for FPI processing was clean enough for an adequate FPI.
2. [Engine part] cleaning personnel receive OJT [on-the-job-training], with no formal classroom training. The team noted that sensitivity to the criticality of the engine components and the end purpose for which these components were being cleaned...was not provided as part of the OJT (critical rotating versus static, general visual inspection versus nondestructive inspection).
3. The solvent on the production floor the morning of August 14 [1996] was badly contaminated with fluorescing material.
4. Visible trash and debris were...under the transport rollers utilized on the FPI line. Since there are no protective covers over the tanks containing the FPI process materials, similar trash and debris is expected in the FPI material.
5. The transport rings utilized for parts holding during the FPI process became easily contaminated with fluorescent material. One inspector was noted having a difficult time inspecting the inside of a hole because of the high fluorescent background from the transport ring visible through the hole. He tried shielding the ring from view with his glove, but it also was contaminated with fluorescent material.
6. One inspector was noted touching the component to be inspected, and smearing the inspection area, before inspecting it.
7. There appears to be no uniform way of handling and indexing components during evaluation in the inspection booth.

The FAA report noted that during and following the inspection team's on-site evaluation, Delta "initiated positive and responsive action's to the team's recommendations." According to Delta's responses to the FAA findings, cleaning personnel now receive training emphasizing different cleaning procedures for critical parts, especially those being prepared for an FPI.⁷¹ In addition, Delta stated that it was working with engine manufacturers to develop cleaning standards for specific parts.

In the report of the review team's findings, "Technical Review of Fluorescent Penetrant Process Delta Air Lines Inc.," the FAA also stated that based on reliability data

⁷¹The FPI inspector who inspected the accident hub at Delta testified during the Safety Board's public hearing that he sent parts back "every day" because they were not adequately prepared by part cleaning personnel.

collected by the Nondestructive Testing Information Analysis Center (NTIAC), "a crack of this size [a total surface length of 1.36 inch on the accident hub] should be detectable with a probability of detection [POD]⁷² and confidence level both exceeding 95 percent." Data compiled by the NTIAC also indicated that the minimum reliable detection length for FPIs is about 0.10 inch.^{73 74}

1.18.4 FAA Accident/Incident Records on JT8D-200 Engines

There were 69 accident/incident reports filed with the FAA between 1990 and July 6, 1996, related to JT8D-200 series engines. A total of 355 service difficulty reports (SDRs) were filed for the same period. Accident/incident data showed no fan hub-related events. One report dated July 13, 1992, stated, "[No. 1] engine failed on takeoff roll. Aborted and returned to gate. Changed engine." No other data on this incident was available. There was one fan hub-related SDR. It stated, "Engine...removed to investigate cause of high titanium content in oil sample found that the C-1 hub had a groove [about] .25-inch deep by .75-inch wide, worn seal ring ...caused by C-1 hub shaft rotating inside of seal ring." The FAA and Delta officials said that they were not aware of any other reported hub defects.

1.18.5 Safety Board Recommendations Subsequent to the Accident

As a result of this accident, actions were taken immediately by Pratt & Whitney, Volvo, the FAA, and the Safety Board to identify any additional defective fan hubs. On July 15, 1996, Pratt & Whitney advised the Safety Board that a review of its production records had identified six additional fan hubs in service that had notations, similar to the one made for the accident hub, made by BEA inspectors after manufacture. Pratt & Whitney subsequently contacted the affected airlines and strongly urged them to remove the hubs from service. The airlines voluntarily complied, and on July 16, 1996, the FAA formalized this action by issuing airworthiness directive (AD) 96-15-06 mandating the removal of the six hubs⁷⁵ from airline service. The hubs were forwarded to Pratt & Whitney where they were subjected to BEAs, FPIs, and eddy current inspections. All of the six hubs were sectioned and underwent metallurgical analysis. No cracks or altered microstructure were found.

On July 29, 1996, the Safety Board issued four safety recommendations to the FAA related to the uncontained engine failure based on its preliminary investigation. The Safety

⁷²A POD provides a statistical means to predict the detectability of cracks and flaws as a function of length or size to quantify and assess the capabilities of a certain NDT process.

⁷³See "Nondestructive Evaluation (NDE) Capabilities Data Book," published by the NTIAC, Texas Research Institute Austin, Inc., DB-95-02, May 1996. Data for the FPI detection section were based on testing conducted on titanium flat plates with fatigue cracks.

⁷⁴A report prepared by the FAA calculated a minimum crack detection length range of between 0.08 inch and 0.10 inch for FPIs (see sections 1.18.7 and 1.18.8 for details of this FAA report).

⁷⁵A review of manufacturing records after the accident revealed that seven fan hubs had BEA inspection indications and one fan hub had FPI indications. Two of the hubs had been scraped during manufacture.

Board's letter to the FAA noted that the failure of the accident fan hub from fatigue cracking "at the location of a BEA indication [at Volvo] raises immediate concerns about other fan hubs that also had BEA indications during inspection and entered into airline service." The July 29 safety recommendations urged the FAA to do the following:

A-96-74

Require that, within 500 cycles of FAA approval of an engine "on wing" eddy current inspection process for Pratt & Whitney JT8D-200 series engine fan hub tierod holes, this inspection be performed on those hubs that have accumulated more than 10,000 cycles since new (CSN); and prioritize the inspections to ensure that the fan hubs most at risk (data suggest those hubs with 10,000 to 15,000 cycles since new) are inspected first. This inspection can be superseded by the redundant inspection urged in safety recommendation A-96-75.

A-96-75

Require an inspection of all Pratt & Whitney JT8D-200 series engine fan hub tierod and SR holes by means of FPI and eddy current by a fixed number of flight cycles based on the risk of crack propagation from manufacturing flaws.

A-96-76

Review and modify the processes as necessary by which Volvo and Pratt & Whitney permitted JT8D-200 series fan hubs to be placed in airline service following indications of mechanical damage in the tierod holes based on the [BEA] inspection.

A-96-77

Review and revise, in conjunction with the engine manufacturers and air carriers, the procedures, training (including syllabi and visual aids) and supervision provided to inspectors for performing FPI and other nondestructive testing of high-energy rotating engine parts, with particular emphasis on the JT8D-200 series tierod and stress redistribution holes.

1.18.6 FAA Responses to Recommendations A-96-74 through -77 and Subsequent Safety Board Responses and Actions

In an October 10, 1996, response to the Safety Board on A-96-74, the FAA agreed that an eddy current inspection of the fan hub tierod holes was needed, but added that SR holes should also be included because "stress levels found in the counterweight holes, although lower than the tierod holes, are sufficient that work hardened material could result in crack initiation and propagation in low cycle fatigue." The FAA letter added that the agency did not believe that an "eddy current inspection can be performed 'on wing' and has concluded that the inspection of the fan hub can only be accomplished through disassembly and fan hub removal, inspection and engine reassembly. The fan hub removal may be accomplished with the engine installed on the

airplane since the removal of the fan hub with the engine attached to the airplane does not inherently increase the risk of a problem occurring when proper maintenance manual procedures are followed.”

In a February 27, 1997, response letter to the FAA, the Safety Board stated that the intent of the “on-wing” inspection was to “ensure the integrity of at least the tierod holes as soon as possible with minimal impact to operators.” The letter stated that the Safety Board was aware that stress levels were higher in tierod holes than SR holes and that it therefore recommended a “quick on-wing eddy current inspection of the higher stressed tierod holes, followed by a thorough FPI and eddy current inspection of the entire hub at a more convenient time. Since the on-wing inspection is not considered viable [because adding SR holes to the inspection required special conditions that ruled out the on-wing procedure], the FAA proposes the removal, cleaning, and initial and repetitive eddy current and FPI of certain fan hubs in lieu of an on-wing inspection procedure.”

After reviewing manufacturing records of JT8D-200 series fan hubs, the FAA divided hubs considered at risk into three categories: Category 1, the highest risk group, included the 8 hubs found in a search after the accident to have had inspection indications during manufacture; Category II, the next highest risk, included 779 fan hubs with tierods and SR holes created by coolant channel drills; and Category III, the lowest risk, included 2,262 fan hubs with tierod and SR holes created by standard high-speed drills. All Category I hubs had been removed from service by AD 96-15-06.

In its February 27 letter, the Safety Board stated that

The initial inspection and the reinspection intervals for the fleet management programs for Category 2 and Category 3 fan hubs are cited in Pratt & Whitney’s Alert Service Bulletin (ASB) No. A6272 [dated September 24, 1996] and are based on Pratt & Whitney’s risk analysis. For Category 2 fan hubs, the initial inspection is optional depending on the desired reinspection interval and can be: 1,050 cycles with a reinspection interval between 2,500 cycles and 6,000 cycles; 990 cycles with a reinspection interval between 2,500 cycles and 8,000 cycles; or 965 cycles with a reinspection interval between 2,500 cycles and 10,000 cycles. For Category 3 fan hubs, the inspection is recommended the next time the hub detail is available in the shop, but the hub is not to exceed 10,000 cycles of operation following the effective date of the ASB.

The Safety Board agrees that the removal, cleaning, and initial and repetitive eddy current and FPI at the interval cited in ASB No. 6272 for Category 2 fan hubs in lieu of an on-wing inspection procedure is appropriate. Based on the FAA action, the Safety Board classifies Safety Recommendation A-96-74 “Open—Acceptable Alternate Response.”

Safety Recommendation A-96-75 asked the FAA to require an inspection of all Pratt & Whitney JT8D-200 series engine fan hub tierod and SR holes by means of FPI and eddy current by a fixed number of flight cycles based on the risk of crack propagation from manufacturing flaws.

The investigation of the Delta Air Lines flight 1288 accident revealed that a localized work-hardened layer was found in the tierod hole of the fan hub from which a crack initiated and propagated to failure after 13,835 flight cycles in low cycle fatigue. The FAA has determined that the work-hardened layer was the result of a coolant channel drill using a single plunge drilling process and that the titanium chips were not cleanly flushed from the hole during the drilling process. The FAA resolved that the chips became wedged between the hole wall and drill shank, which caused a localized, work-hardened layer.

Previous to the accident, on February 17, 1982, a fan hub on a Pan American World Airways Boeing 727 with a Pratt & Whitney JT8D-7B engine experienced an uncontained failure during takeoff at Miami International Airport, Miami, Florida.⁷⁶ Postaccident analysis of the failed fan hub revealed that a crack developed from an area of abusive machining in one of the tierod holes installed with a standard drill using the multi-step drilling process rather than a coolant channel drill and the single plunge process. Although the Pan American accident hub was from a smaller JT8D-7 series engine, the titanium alloys were identical, and the hub design was similar to the JT8D-200 series engine, which incorporates deep tierod holes that pass through the thick rim section.

Because of the similarities between the Delta MD-88 and the Pan American B-727 fan hubs and the failures of these fan hubs, the Safety Board disagrees with the FAA's conclusion that the work-hardened layer on the tierod hole wall can only be the result of a coolant channel drill using a single plunge drilling procedure. The Safety Board believes that hubs classified as 'Category 3' by the FAA should not be considered separately from Category 2 hubs. Because the FAA did not provide for any initial inspection of Category 3 hubs in the notice of proposed rulemaking (NPRM) issued on September 27, 1996, the Safety Board classifies Safety Recommendation A-96-75 "Open—Unacceptable Response."

⁷⁶The fan hub failed at 9,361 cycles, and metallurgical examination indicated a fatigue striation count of about 7,300 cycles. The failed part received BEA, FPI, visual, and dimensional inspections during manufacture. It also received a visual inspection at 4,056 cycles, a second visual inspection at 5,317 cycles, and an FPI and dimensional inspection at 6,578 cycles.

In issuing AD 97-02-11, which went into effect on March 5, 1997, following the NPRM, the FAA said it did not concur with the Safety Board that Category 3 fan hubs should be inspected at the next shop visit for hubs that have between 10,000 cycles and 15,000 CSN. The FAA response stated, "The FAA's analysis of this problem indicates that hubs manufactured using coolant-channel drills are more susceptible to work hardened areas in the tierod and counterweight holes that could serve as a crack origin. The FAA concludes, therefore, that it is logical to treat these two distinct populations of compressor hubs differently in terms of when operators must perform the required inspections. Requiring all hubs to be inspected according to the coolant-channel drill schedule is not supported by the available data."

In a March 24, 1997, letter to the Safety Board, the FAA stated that it had revised its fan hub inspection program outlined in AD 97-02-11 based on a determination that BEA inspection "is effective in detecting work hardened material and that a major event in production has an increased likelihood of causing work hardened/deformed material." The FAA letter added

A major event such as a tool breakage would be noted by an operator or inspector on the traveler, which is the production record that accompanies a part through a manufacturing shop. In such an event, work hardened/deformed material can be caused by either a standard or coolant channel drill. Therefore, all fan hub records were reviewed, and those fan hubs with any notations regarding burned drills, marks on tool, broken drill tool, chatter, surface finish, or dimensional anomalies have been identified as a new suspect population. A total of 253 fan hubs with such notations have been identified consisting of 113 coolant channel drilled and 140 standard drilled fan hubs (non channel drilled). The FAA has determined that these fan hubs must be inspected with a more aggressive field management program.

Safety Recommendation A-96-76 was also addressed in the Safety Board's February 27, 1997, letter

Safety Recommendation A-96-76 asked the FAA to review and modify the processes as necessary by which Volvo and Pratt & Whitney permitted JT8D-200 series fan hubs to be placed in airline service following indications of mechanical damage in the tierod holes based on a BEA inspection.

The Safety Board notes that the 'standard masters' [templates] that [further broaden rejectable BEA] conditions...are being revised for disks, hubs, couplings, blade retainers, rotating air seals, and rotating spacers. Also, Pratt & Whitney is expanding the Materials Control Laboratory Manual to include photographs as examples of abusive machining. Finally, fan hubs currently in production are inspected to the new standard. Because the FAA's actions are responsive to the intent of the recommendation, the

Safety Board classifies Safety Recommendation A-96-76 "Closed—Acceptable Action."

Pending review of final FAA action, the Safety Board, in its February 1997 letter, classified Safety Recommendation A-96-77 "Open—Acceptable Response" after the FAA stated that it had "conducted an inspection review of the Delta Air Lines facility...and is satisfied that Delta Air Lines has the proper guidance for training and qualifying personnel in nondestructive testing methods and the performance of FPI." The FAA also stated, "Additionally, the FAA is developing a 6-month action plan to conduct an evaluation of other facilities that do FPI and other nondestructive testing of high-energy rotating parts." Based on the FAA's March 1997 letter, the Safety Board continues to classify Safety Recommendation A-96-77 "Open—Acceptable Response."

1.18.7 Related Safety Board Recommendations from the Accident Involving United Airlines Flight 232, Sioux City, Iowa

On June 18, 1990, the Safety Board issued two longer-term safety recommendations to the FAA related to inspections based on detectable crack size. The recommendations were made following a July 19, 1989, accident involving a United Airlines DC-10-10 that experienced an in-flight separation of the stage 1 (titanium) fan disk in the No. 2 tail-mounted General Electric CF6-6 engine.⁷⁷ The failure led to the loss of the three hydraulic systems that powered the airplane's flight controls and subsequent loss of control during an attempted landing at Sioux Gateway Airport, Sioux City, Iowa. The accident killed 111 passengers and 1 crewmember. The Safety Board determined that the stage 1 titanium fan rotor disk assembly failure was caused by a fatigue crack that initiated from a Type I hard alpha metallurgical defect on the surface of the disk bore.⁷⁸ The Safety Board concluded that the defect, or inclusion, was formed in the titanium alloy material during manufacture of the ingot from which the disk was forged. Based on a count of the fatigue striations, the Safety Board determined that at least two FPIs were conducted after the crack had reached a detectable length on the disk surface.

As a result of that accident, the Safety Board recommended that the FAA do the following:

⁷⁷National Transportation Safety Board. 1990. *United Airlines Flight 232, McDonnell Douglas DC-10-10, Sioux Gateway Airport, Sioux City, Iowa, July 19, 1989*. Aircraft Accident Report NTSB/AAR-90/06 Washington, DC. The report concluded that a metallurgical defect was formed in the titanium alloy material during manufacture of the ingot from which the fan disk was formed and that a cavity associated with the defect was created during the final machining and/or shotpeening of the disk. The defect cracked as a result of stress during the disk's initial exposures to full engine thrust and grew until it extended beyond the defect area.

⁷⁸Type I hard alpha inclusions result from localized excess amounts of nitrogen and/or oxygen that have been introduced through atmospheric reactions with titanium in the molten state. A typical hard alpha inclusion contains an enriched alpha zone in the alpha plus beta matrix; voids or cracks are commonly associated with the hard, brittle alpha phase inclusion.

A-90-89

Evaluate currently certificated turbine engines to identify those engine components that, if they fracture and separate, could pose a significant threat to the structure or systems of the airplanes on which the engines are installed; and perform a damage tolerance evaluation of these engine components. Based on this evaluation, issue an Airworthiness Directive to require inspections of the critical components at intervals based upon the crack size detectable by the approved inspection method used, the stress level at various locations in the component, and the crack propagation characteristic of the component material.

A-90-90

Amend 14 CFR Part 33 to require that turbine engines certificated under this rule are evaluated to identify those engine components that, if they should fracture and separate, could pose a significant threat to the structure or systems of an airplane; and require that a damage tolerance evaluation of these components be performed. Based on this evaluation, require that the maintenance programs for these engines include inspection of the critical components at intervals based upon the crack size detectable by the inspection method used, the stress level at various locations in the component, and the crack propagation characteristics of the component material.

In response to these recommendations, the FAA formed the Titanium Rotating Components Review Team (TRCRT) to assess the quality control procedures used in the manufacture of titanium alloy high-energy rotating components of turbine engines. The team submitted a report to the FAA on December 14, 1990 (see section 1.18.9 for details and recommendations contained in the team's report).

In an April 6, 1993, letter to the Safety Board in response to these recommendations, the FAA Administrator stated that a proposed implementation schedule for safety recommendations contained in the TRCRT report had been canceled following a May 1991 industry conference on the issue. The letter stated industry responses "strongly [indicated] that the proposed implementation schedule needed to be modified." The FAA letter stated that committees and teams had been created to focus "FAA and industry resources in developing the appropriate actions relating to the pertinent recommendations of the titanium report" and would "develop implementation schedules commensurate with the needs of the FAA, industry, and the flying public." In a response specific to A-90-90, the FAA stated that 14 CFR Part 33 was adequate and did not need to be revised.

On May 28, 1993, the Safety Board classified both safety recommendations "Closed—Acceptable Alternate Action," stating its belief that the FAA was "seriously considering application of damage tolerance concepts to critical rotating components in existing and future engines." The Safety Board is unaware that any new implementation schedules were developed or that any further action was taken by the FAA to implement the recommendations in the TRCRT report.

1.18.8 Other Uncontained Engine Failures

In addition to the Pan American B-727 incident discussed in section 1.18.6 and the United Airlines accident just discussed, the Safety Board examined several recent engine failures involving Pratt & Whitney and General Electric engines.

On September 7, 1997, a Canadian Airlines B-767-300ER experienced an uncontained engine failure during its initial takeoff run in Beijing, China. The takeoff was rejected. When the airplane returned to the terminal, holes were found in the engine cowling, along with a 1-inch by 2-inch hole in the fuselage. The airplane was equipped with two General Electric CF6-80C2B6F engines. An initial examination of the failed engine conducted by the Canadian Transportation Safety Board (CTSB) indicated that the rim in the 3rd-stage of a high-pressure compressor (HPC) stage 3-9 spool had ruptured and segments had exited the compressor case.

An initial metallurgical examination identified a fatigue crack about 1 3/4-inch wide and about 1/2-inch deep emanating from abnormal microstructure in the area of the blade slot bottom. The fracture area has features that, on initial examination, appear similar to past failures of the higher stages (6th-9th) of the spool caused by dwell time fatigue.⁷⁹ The two-piece spool was manufactured from a 9-inch and a 10-inch diameter billet.⁸⁰ The part failed at 4,744 cycles. It received FPI and ultrasonic inspections at 2,785 cycles, or 1,959 cycles before the failure.⁸¹ The accident remains under investigation, and the exact fracture mechanism of this spool has not been determined.

General Electric records also indicate that a DC-10 airplane experienced an uncontained separation of a HPC stage 3-9 spool on the tail-mounted CF6-50C2B engine during takeoff in Bangkok, Thailand, on May 11, 1995.⁸² There was no loss of flight control, and the airplane returned to the airport without incident. There were no injuries. The spool was

⁷⁹Dwell time fatigue refers to a fracture mechanism in which progressive crack growth occurs during cyclic loading (rise and fall of stress) and also over time during sustained peak stress loading (during the dwell time at the peak stress level) both at low temperature. Dwell time fatigue is substantially less than fatigue life under continuous (not dwelled at peak stress) fatigue loading. The fracture morphology is characterized by subsurface initiation and flat faceted cleavage fracture features. According to GEAE, the phenomenon is related to increased plastic strain and slip along crystallographically aligned alpha colonies in the material microstructure. Although the exact mechanism of dwell time fatigue has not yet been fully established, and the phenomenon is not yet fully understood, researchers also indicate that it can be associated with hydrogen embrittlement and high dwell stress states.

⁸⁰A billet is a semi-finished round product hot-forged from ingots to the approximate diameter of the disk or spool before it is forged.

⁸¹Before 1991, General Electric performed macroetch and ultrasonic inspections on the rectilinear part shape (before the part was cut to its final shape during manufacture). General Electric now performs BEA inspections on the finished part.

⁸²See Safety Board Recommendations A-95-84 and -85, August 25, 1995.

manufactured from a 13-inch diameter billet and had accumulated 8,438 cycles since new. A metallurgical examination determined that the stage 8 disk in the HPC rotor stage 3-9 spool contained a fatigue fracture in the forward face of the disk bore. The fatigue crack extended 0.80 inch in the radial direction and 0.57 inch in the axial direction. Fracture features appeared consistent with dwell time fatigue. According to General Electric, the spool had undergone ultrasonic and FPI inspections in April 1991, at 7,107 cycles (1,331 cycles before failure). During the ultrasonic inspection, a defect indication (a crack about 0.24 inch in length) was found in the area of the fatigue crack failure. The disk was reworked, and the spool passed an inspection and was returned to service, according to General Electric.

General Electric has identified two other HPC stage 3-9 spools that separated as a result of dwell time fatigue. A DC-10-30 experienced an uncontained failure during takeoff climb at Dakar, Senegal, in 1985 when the stage 9 portion of the spool ruptured in the tail-mounted CF6-50 engine at 4,075 cycles. The spool had been manufactured from a 16-inch billet. According to General Electric, the second separation occurred in 1991 in Seoul, South Korea, and involved a stage 9 portion of the spool with 10,564 cycles in a CF6-50 engine.

The Safety Board investigated another incident in October 1993 involving an uncontained separation of the HPC rotor stage 3-9 spool on a CF6-80C2 engine on an Airbus A300-605R during takeoff climb from Los Angeles International Airport. The flightcrew declared an emergency and returned to the airport. An examination revealed that the stage 6 portion of the spool had fragmented and ruptured the engine case, but this portion of the spool was never recovered. The spool was manufactured from a 13-inch diameter billet, had accumulated 4,403 CSN, and had received no in-service inspections. Metallurgical examination indicated that the material contained aligned alpha colonies, and because of this, it is suspected that the failure resulted from dwell time fatigue. However, fatigue stemming from a hard alpha inclusion could not be ruled out.

A hard alpha inclusion was also determined to have caused a fatigue fracture that resulted in the uncontained separation of the stage 3-9 HPC rotor spool of a CF6-50C2 engine on an Airbus A300-B4 during takeoff roll at Cairo, Egypt. The Egypt Air flightcrew rejected the takeoff, stopped the airplane on the runway, and ordered an emergency evacuation. A postaccident metallurgical examination by the Safety Board revealed that the failure was caused by a fatigue fracture in the stage 6 portion and that fatigue cracking had initiated from a nitrogen-stabilized hard alpha inclusion located on the aft side of the disk web. Maintenance records indicated that the stage 3-9 spool had accumulated 8,264 cycles and was subjected to an FPI in March 1992, at 6,745 cycles (1,519 cycles before failure), when the compressor section was overhauled. The Safety Board determined that the crack began propagating early in the part's service life, perhaps with the application of the first cycle of stress.

The Safety Board also investigated a June 8, 1995, uncontained engine failure (involving a nontitanium part) and fire on a DC-9-32. The failure was caused by a fatigue crack in the 7th-stage steel HPC disk of a Pratt & Whitney JT8D-9A turbofan engine. The ValuJet Airlines flightcrew rejected the takeoff. A cabin fire erupted after engine debris penetrated the fuselage and the right engine main fuel line. The Safety Board's investigation determined that

the disk failed at 16,340 cycles and had been subjected to a magnetic particle inspection (MPI)⁸³ in 1991 at 11,907 cycles. The Safety Board concluded that a detectable crack existed in an SR hole when the disk was overhauled and inspected in 1991.

1.18.9 Results of FAA-Sponsored Titanium Rotating Components Review Team

The FAA's TRCRT report, submitted to the FAA's Engine and Propeller Directorate in 1990, "considered all pertinent design, manufacturing, quality control, and inspection procedures used in the production of life-limited, rotating, high energy titanium components." The report said the team focused its review on "design and manufacturing (including nondestructive inspection [NDI] phases of the life cycle of titanium critical parts, large titanium alloy fan hubs and disks installed on turbofan engines)." The report noted that a detailed review was not conducted of "continued operational safety procedures (specifically operator NDIs) from the time that life-limited parts enter service with the user until their permanent retirement." The report stated that the review team had determined, based on data it collected, that 24 titanium disks had "failed [burst or cracked] in commercial service, due to metallurgical defects, prior to the Sioux City disk." Metallurgical reports on the defective disks, some "dating as far back as 1964, were submitted for review to the [TRCRT] by four engine manufacturers."⁸⁴ Defects included Type I inclusions, Type II (aluminum-rich alpha stabilized segregation) inclusions, other segregation types (nonuniform distribution of impurities, inclusions or grain sizes), voids (unfilled space in grain structure), or porosity.

The review team concluded "that the random approach of inspections of opportunity is not adequate, and can no longer be justified." The TRCRT stated that this conclusion was based on the "frequency of occurrence of titanium metallurgical defects, the difficulty of detecting defects in titanium,...the many sources of defects, errors and damage, recent developments in the engineering science of fracture mechanics (crack propagation) analysis" and developments in reliability simulation analysis.

The TRCRT report noted, "for the first time, a scientific approach to the determination of a safe inspection frequency for commercial engine disks is believed practicable through application of...newly improved engineering sciences. But the implementation of this approach will be a major task for the industry as well as the FAA...Therefore, until the engine manufacturers have time to: develop the necessary engineering data [flaw size distribution and detection probability]...complete the analyses, develop and manufacture the necessary inspection tooling, and coordinate implementation plans with the aircraft owners/operators, an interim plan should be implemented (within 6-12 months)."

⁸³ MPI is a nondestructive method of detecting cracks and other defects in ferromagnetic materials such as iron or steel.

⁸⁴ The TRCRT report noted, "most disks melted prior to 1970 have reached their service life limit and have been retired."

Referring to this interim plan for in-service inspections of titanium parts (produced before and after 1984),⁸⁵ the report recommended that

1. In the near term, for parts already in service, supplement the engine shop manuals' required [FPIs] with an eddy current inspection of the most critical (highest stressed) areas, whenever the engine is disassembled sufficiently to afford access to a major rotating part (inspections of opportunity).
2. As a longer-term interim measure for parts already in service, require, in addition to the enhanced surface inspection, a subsurface inspection (e.g., ultrasonic) at least twice during each component's certificated cyclic life, at intervals acceptable to the Administrator. [At about 1/3 and 2/3 intervals during the part's operational life].

The report concluded that the proposed interim plan, although "less scientific than a fracture mechanics technology approach," is "more positive (less random) and more defect-sensitive than the current inspections-of-opportunity approach."

The report added

The advantages of inspecting at approximately 1/3 and 2/3 of the disk's certificated cyclic life are that the disk is looked at early in its operational life in order to discover any gross error, defect or damage that could result in [early rupture]; and the disk is looked at fairly late in its operational life when the probability of cracking has substantially increased. (The probability of fatigue cracking increases throughout a disk's cyclic life).

For titanium parts produced before 1985, the report recommended that criteria be developed "within two years, to inspect all critical life-limited, in-service parts at intervals established by fracture mechanics technology (see section 1.18.1)." For titanium parts produced in 1985 and after, the report recommended that criteria be developed "within three years to inspect all critical, life-limited, in-service parts at intervals established by fracture mechanics technology."

The report also recommended that the FAA Engine and Propeller Directorate, Aircraft Certification Service

1. Retain the current practice of retiring critical parts at pre-determined cyclic lives;

⁸⁵The report said that a number of important improvements were made in 1984 in the design, manufacturing, and quality control systems of titanium rotating parts.

2. Require life management methodologies to consider the effect of metallurgical defects on part life, accounting for the maximum defect sizes which may be missed during production and in-service inspections; and,
3. Consider convening, within about six months, an industry-wide fracture mechanics/damage tolerance, NDI, and probabilistic/deterministic risk management conference (or other suitable forum) to discuss the incorporation of damage tolerance concepts in commercial engines.

In the areas of research and development, the report recommended that the FAA fund an "aggressive (short term) research and development program to establish industry-wide probability of detection (POD) curves for FPI, ultrasonic, and eddy current, manufacturing and in-service inspection methods and processes." It said that POD data should address the effects of surface treatments, including shotpeening, "which tend to obscure cracks or defects."

The report stated that a national standard should be developed "to identify minimum qualifications and required training and examinations, for NDI personnel at all levels of expertise" and that "industry-wide certification of NDI personnel should be required." The report stated that the FAA should "develop new advisory material on lifing analysis and life management procedures for engine life-limited parts."

The report also concluded that current methods used by engine manufacturers to establish "safe life" limits for rotating parts do not account for flaws that could be missed by initial inspection methods. The report recommended that "life management methodologies" be developed to "consider the effect of metallurgical defects on part life, accounting for maximum defect sizes which may be missed during production and in-service inspections."

2. ANALYSIS

2.1 General

The flightcrew was properly certified and trained for the flight and was in compliance with Federal flight and duty time regulations. The flight attendants had completed Delta's FAA-approved flight attendant training program. The airplane was properly certificated and maintained in accordance with applicable Federal regulations, including an FAA-approved airworthiness maintenance program. Visual meteorological conditions prevailed, and weather was not a factor in the accident. No preexisting problems were found with the engines, except for the crack in the fan hub on the No. 1 engine. The oil observed preflight by the first officer came from the No. 1 bearing housing and, therefore, was not a precursor to the accident.

2.2 Fan Hub Fracture

The left engine fan hub fractured early in the takeoff roll when the airplane was at low speed during normal operation. The actions of the flightcrew did not contribute to the failure of the fan hub.

Metallurgical examination of the microstructure underlying the surface of the tierod hole (closest to the hole wall surface) in the origin areas determined that the material was severely deformed and hard. The appearance of the microstructure suggested high frictional heat. Laboratory analysis indicated that the microstructure contained an oxygen stabilized layer of recrystallized alpha grains adjacent to the surface of the tierod hole. This indicated that the temperature at the surface of the hole in the damaged area had reached at least 1,200°F, the minimum recrystallization temperature for titanium. Iron was also found in this layer of altered microstructure, both widely dispersed and in a high concentration within small isolated bands.

Although stabilized alpha is often associated with an inclusion in the titanium alloy created during the melting or forging process, it can also be formed during machining operations when tools overheat titanium alloy in the presence of air. The location and appearance of the accident hub's altered microstructure indicated that the deformation was formed by a tool used in creating the tierod hole.

Volvo test drillings conducted after the accident produced altered microstructure in two holes, one of which contained features very similar to the accident hub. Test drilling was conducted without coolant and at higher drill revolution and feed speeds to promote tool (drill) breakage and the accumulation of chips in the hole. According to Volvo's report, altered microstructure "can be created during rough [initial] drilling, but not during subsequent boring and honing operations."

According to Volvo, the hole with defect features that most resembled those of the accident hub had a microstructure that was "heavily deformed" and had a hardness that corresponded "with the values for the failed hub." An analysis determined that the layer of

deformed microstructure contained ladder-type cracking and "a high concentration of iron from the drilling operation."⁸⁶

Because the high temperature (at least 1,200°F) required to form the altered microstructure could not have existed if coolant were flowing freely over the area, the Safety Board considered the possibility that the coolant channel drill malfunctioned. However, because a complete cessation of coolant flow over the hub would have been readily noticeable by the drill operator, the loss of coolant to the area of the altered microstructure was more likely caused by a brief obstruction to the coolant reaching that particular area, such as would result from chip packing or broken pieces of a drill bit. Therefore, chip packing or wedging, leading to a temporary, localized loss of coolant most likely contributed to the creation of the altered microstructure. Thus, the Safety Board concludes that some form of drill breakage or drill breakdown, combined with localized loss of coolant and chip packing, occurred during the drilling process, creating the altered microstructure and ladder cracking in the accident hub. Based on the number of fatigue striations found in the fatigue fracture region, which was roughly equivalent to the number of the hub's flight cycles, the Safety Board further concludes that the fatigue cracks initiated from the ladder cracking in the tierod hole and began propagating almost immediately after the hub was put into service in 1990.

2.3 Analysis of Volvo's Inspection Procedures

A BEA test conducted by the Safety Board on the sectioned accident hub revealed a dark blue indication in the areas of the altered microstructure. However, the accident hub passed BEA and visual inspections at Volvo following the drilling process that created the anomalous microstructure. Although the BEA inspector at Volvo noted on a shop traveler that he observed "manufacturing marks" inside a hole, at a subsequent visual inspection, inspectors determined that all the holes conformed to Pratt & Whitney acceptance criteria for surface finish on bolt holes. Postaccident metallurgical analysis confirmed that the surface finish in those areas of the tierod hole was consistent with the surface finish requirements specified by Pratt & Whitney. The Safety Board's examination determined that there was no evidence of excessive machining marks at the surface of the hole. It could not be determined whether the BEA inspector made the notation of "manufacturing marks" because of the different surface finish in the tierod hole (boring marks surrounded by honing marks), because of a different coloration resulting from the BEA inspection process, or for some other reason.

The Volvo manager who testified during the Safety Board's public hearing stated that the notation by the BEA inspector of "manufacturing marks" in the hole did not signify that the inspector had observed a BEA discrepancy based on the BEA defect templates in use at the time, and he stated that this notation was only intended to alert inspectors conducting subsequent visual inspections, with different inspection criteria. Thus, the Safety Board concludes that although the altered microstructure in the accident hub tierod hole was detectable by BEA

⁸⁶Drill breakdown, for example, could cause minute parts of the drill to shear off during the drilling process.

inspection methods, Volvo did not identify it as rejectable because the appearance of the tierod hole did not match any of the existing inspection templates showing rejectable conditions. The Safety Board notes that BEA inspections conducted by Pratt & Whitney on six fan hubs recalled by the FAA's emergency AD revealed no evidence of cracks or surface discontinuities in the holes, although manufacturing records contained remarks similar to those made by the BEA inspector on the accident hub's inspection records.

The failure of the manufacturer's BEA inspection to detect and identify a rejectable condition in the accident hub after the drilling process at Volvo resulted in the postaccident development and addition of four new templates to assist in identifying microstructural defects similar to the accident hub for use by BEA inspectors. The Safety Board recognizes that the BEA inspection process places interpretive demands on inspectors, that identification of rejectable conditions may still not be complete, and that templates of defect indications are added when they are encountered and identified. The Safety Board concludes that although the additional templates will assist BEA inspectors in detecting potential defects similar to the one that existed on the accident hub, this accident suggests that there may be additional rejectable conditions that have not yet been identified. The Safety Board is concerned that these problems may not be unique to parts manufactured by Pratt & Whitney. Therefore, the Safety Board believes that the FAA should form a task force to evaluate the limitations of the BEA and other postmanufacturing etch processes and develop ways to improve the likelihood that abnormal microstructure will be detected. In so doing, it may be appropriate to consider whether any part of these processes can be automated, so as to minimize the possibility of human error.

When Pratt & Whitney approved Volvo's request to use a coolant channel drill, this change was approved because Pratt & Whitney's engineering data indicated that changes in drilling operations were "insignificant" as long as subsequent boring and honing operations were carried out to a depth of at least .010 inch to remove material (including defects) created by the drilling phase. The total depth of material removed from the tierod hole after drilling on the accident hub was about .0185 inch. Metallurgical examinations conducted by the Safety Board after the accident indicated that the total depth of the altered microstructure created by the drill was about .024 inch, more than twice the depth anticipated by the .010-inch limit set by Pratt & Whitney. The Safety Board concludes that drilling damage in this accident hub extended much deeper into hole sidewall material than previously anticipated by Pratt & Whitney. Thus, the Safety Board believes that the FAA should inform all manufacturers of titanium rotating engine components of the potential that current boring and honing specifications may not be sufficient to remove potential defects from holes and ask them to reevaluate their manufacturing specifications and procedures with this in mind.

2.4 Failure of Delta Maintenance to Detect Cracking in the Accident Hub

The crack was not likely detectable at the time of the hub's January 1992 visual inspection. (At that time it would have been approximately 0.1-inch deep and 0.2-inch along the hole wall.) However, given the limitations of the tools used to accomplish the visual inspection at that time (magnifying glass and white fluorescent light), even if the crack had been larger, the probability of detection would likely have been lower than if more effective tools (such as a

borescope) had been used. The Safety Board notes that Delta's current practice of using borescopes to accomplish these visual inspections is an improvement that should increase the probability of detection during visual inspections.

On October 27, 1995, Delta's maintenance facility in Atlanta, Georgia, performed an FPI on the accident hub. This inspection, conducted 1,142 cycles before the accident, was part of overhaul work recommended in Pratt & Whitney's engine shop manual for hubs disassembled from engines before reaching their "safe life" limits.

Postaccident metallurgical examinations conducted by the Safety Board indicated that based on the striation count, at the time of the last FPI the crack on the aft hub surface adjacent to the tierod hole was about 0.46-inch long and that this crack extended about 0.90 inch within the tierod hole, for a total surface length of 1.36 inches. The FAA's review of FPI processes at Delta concluded that based on reliability data collected by the Nondestructive Testing Information Analysis Center (NTIAC), a visible crack of this size should have been detectable with both a probability of detection and confidence level exceeding 95 percent. The crack was well above the minimum detection length of 0.10 inch as calculated by the NTIAC's NDE capabilities Data Book, and the 0.08-inch and 0.10-inch range suggested in the FAA's TRCRT. Therefore, the Safety Board concludes that the crack was large enough to have been detectable during the accident hub's last FPI at Delta.

The Safety Board considered the possibility that the crack was not visible during the FPI at Delta. The Safety Board's investigation found that there are a number of ways in which the effectiveness of the FPI process could have been compromised by improperly performed or inadequate procedures. These issues are discussed in section 2.4.1. The Safety Board also considered the possibility that the crack was visible at the time of the FPI, but that the FPI inspector either overlooked it or discounted it as insignificant. These issues are discussed in section 2.4.2.

2.4.1 Part Cleaning, Drying, Processing, and Handling

The FAA's postaccident report of an August 1996 inspection of the FPI process used by Delta indicated that there was no assurance that parts received by FPI operators were "clean enough for an adequate FPI." The FAA report also noted that cleaning personnel were not made aware of the "criticality of the engine components and the end purpose for which these components were being cleaned." The inspector who inspected the accident hub indicated that he frequently had to send parts back for additional cleaning. The Safety Board recognizes that following the FAA's technical review of Delta's FPI process, Delta indicated that it was providing cleaning personnel with training to emphasize different cleaning procedures for critical parts, especially those being prepared for FPI, and that it was working with engine manufacturers to develop cleaning standards for specific parts. However, the Safety Board is concerned that similar shortcomings may exist at other maintenance facilities performing FPIs.

At the conclusion of the cleaning process in preparation for an FPI at Delta, parts were immersed in a "hot water rinse" and flash dried (see section 1.18.1). Because the dye

penetrant applied later in the process has an oil base, any water remaining in cracks would block entry of the dye into those areas. For the flash drying process to be effective, the part must be heated to the temperature of the water, which must be kept at a temperature of between 150° and 200°, according to Pratt & Whitney's OSPM and Delta's Process Standard. A temperature measuring device was not used to determine whether parts had reached the temperature of the water. Rather, according to a Delta representative, operators determined that parts had reached the proper temperature by "feel" and that the water temperature was checked on a weekly basis. After the accident and the FAA inspection, Delta implemented changes requiring more frequent checks of the water temperature.

Delta's director of compliance and quality assurance testified at the public hearing that flash drying may not be effective in areas where water is trapped, in areas "that you can't readily see or flaws...." A representative of a company that produces FPI hardware and chemicals testified that "it's absolutely imperative that the parts come to the process clean and dry." Another witness from a company that provided Delta with chemicals for the FPI process stated that the effectiveness of flash drying depends on the depth of the crack. "If it's a fairly deep crack...it's doubtful whether you're going to remove that [water] from a fatigue crack," the chemical company witness stated.

Although it could not be conclusively determined whether water trapped in the crack at the time of the FPI rendered the crack undetectable by this method, the Safety Board is concerned that a number of experienced practitioners in the field believe that such a potential exists when flash drying is the only drying method used. The Safety Board concludes that significant questions exist about the reliability of flash drying in removing water from cracks.

With regard to the processing of parts after drying, specifically, the application of developer powder, the Safety Board is concerned that when only a spray gun applicator was used, the powder did not cover the hole walls along the full depth of the hole. The Safety Board is further concerned that even using a more focused application tool, such as a squeeze bulb, the geometry of the hub may be such that full coverage of hole walls may never be possible. Although in this case that deficiency would not have prevented detection of the crack (because there was also a sizable crack on the aft face of the hub), under other circumstances this incomplete coverage may result in nondetection of an otherwise detectable crack. Therefore, the Safety Board concludes that better techniques are needed to ensure the fullest possible coverage of dry developer powder, particularly along hole walls.

Safety Board observers also found that Delta had no formal logging procedure to identify parts ready for inspection (inspection must occur within 2 hours of the application of the developer powder and indications found after 1 hour are considered questionable). Delta representatives indicated that shop personnel relied on a "group knowledge" of how long a part had been ready for inspection.

The time between application of the developer and inspection must be controlled to maximize the brilliance of indications (which increases over time), and yet ensure that sufficient dye penetrant remains in the defect for diagnostic activities. Delta inspectors described

a method for part tracking in which they coordinated with processors to control the flow of parts so that the time limit would not be exceeded. This informal system would have been vulnerable to error from the difficulty of estimating how long an inspection of the part will take inside the booth, worker distraction, and the potential for the loss of collective knowledge during shift turnover. Thus, it could not have been possible for Delta personnel to consistently adhere to the development time requirements using this system or to know exactly how long a part had been ready for inspection. The Safety Board is concerned that Delta had timing requirements in its process standard but failed to provide its personnel with a way to adhere to them. Thus, there is no assurance that the accident hub was inspected within the limits set forth in the process standard. Although it could not be conclusively determined whether this played a role in the nondetection of the crack in the accident hub, the Safety Board concludes that the absence of a system that formally tracks the timing of the movement of parts through the FPI process was a significant deficiency. The Safety Board notes that after the accident, Delta implemented a procedure to record part development times on a status board that formalizes part tracking and adherence to time requirements. However, the Safety Board is concerned that other operators and repair stations might not have adequate methods to positively identify the status of parts processed for FPIs.

During the FPI process at Delta, hubs are placed aft-side down on a plastic disk to keep them from contacting the rollers on the FPI line during inspection. Processors and inspectors used their hands to lift and turn the hub on the plastic disk to gain access to the aft-side and interior. During these lifting actions, it would have been difficult for personnel to ensure that they were not touching the hub in an area with an indication, particularly on the aft-face. FPI experts testified at the public hearing that penetrant could be rubbed off during handling. If penetrant was prevented (by dirt or water) from fully entering the crack, then rubbing off the surface penetrant would probably have removed any indication of the crack. But even if penetrant was in the crack, loss or distortion of penetrant at the surface could have resulted in an ill-defined indication, thus making the crack more difficult to detect. Although the extent to which it contributed to the nondetection of the crack could not be determined, the manual handling of the hub at Delta during the processing and inspection of the accident hub increased the opportunity for smearing of an indication on the aft-face. The Safety Board notes that after the accident, Delta advised its FPI personnel to minimize manual handling of hubs and to use support equipment, such as an overhead hoist, in the inspection booth.

The Safety Board previously addressed manual handling and methods to support parts during FPI following the United DC-10 accident at Sioux City, which was also caused by a crack in a critical rotating part.⁸⁷ The Safety Board report on that accident stated:

It is possible that the inspector...did not rotate the disk, as it was suspended by a cable, to enable both proper preparation and subsequent viewing of all portions of the disk bore, particularly the area hidden by the suspension cable/hose.

⁸⁷Op. Cit. Footnote 77.

The Safety Board is concerned that deficiencies in the methods for handling critical rotating parts during FPI have been identified in this accident and in the United Airlines accident in Sioux City, Iowa. The Safety Board concludes that FPI indications remain vulnerable to manual handling, and fixtures used to support the part during inspection may obstruct inspector access to areas of the part.

Further, the Safety Board concludes that one or more procedural deficiencies in the cleaning, drying, processing, and handling of the part might have reduced or prevented the effectiveness of Delta's FPI process in revealing the crack. The Safety Board also concludes that the potential deficiencies identified in the Delta FPI process may exist at other maintenance facilities and be, in part, the reason for the failure to detect cracks in other failed engines identified in this investigation. (See section 1.18.8.) Therefore, the Safety Board believes that the FAA should establish and require adherence to a uniform set of standards for materials and procedures used in the cleaning, drying, processing, and handling of parts in the FPI process. In establishing those standards, the FAA should

1. Review the efficacy of drying procedures for aqueously cleaned rotating engine parts being prepared for FPIs;
2. Determine whether flash drying alone is a sufficiently reliable method;
3. Address the need to ensure the fullest possible coverage of dry developer powder, particularly along hole walls;
4. Address the need for a formal system to track and control development times; and
5. Address the need for fixtures that minimize manual handling of the part without visually masking large surfaces of the part.

2.4.2 Human Factors Related to Inspector Performance

Despite the procedural deficiencies outlined above, it is possible that the preinspection steps in the FPI process were accomplished adequately. In that case, the crack in the accident hub would have been detectable at the time of the October 1995 FPI at Delta. However, the inspector's failure to remove the hub from service indicated that he either did not observe the crack, or he observed it but did not realize or confirm it was a crack.

The inspector who conducted the FPI on the accident hub was in good health, had passed company vision examinations 3 months before the inspection, and had been assigned stable work hours at the time of the inspection. The inspector was trained in accordance with company policy, and was qualified to document the results of his inspection on the part's shop traveler without the work being signed off by a supervisory inspector. The FPI shop foreman described the inspector as capable and competent. Therefore, the Safety Board concludes that no personal or physical factors would have prevented the inspector from detecting a visible crack in the accident hub. Accordingly, the Safety Board considered several other factors that might have contributed to the inspector's failure to detect the crack.

2.4.2.1 Lack of a Formal Method to Ensure Completeness of Search and Diagnostic Followup

To detect the crack on the aft-face of the hub, the inspector would have had to first detect a bright fluorescent green indication (if there was such an indication) against a dark purple background.⁸⁸ To detect the indication, the inspector would have had to systematically direct his gaze across all surfaces of the hub. However, systematic visual search is difficult and vulnerable to human error. Research on visual inspection of airframe components, for example, has demonstrated that cracks above the threshold for detection are missed at times by inspectors because they fail to scan an area of a component.⁸⁹ Delta FPI inspectors described inspecting major areas on the -219 hub in the same order each time. Although this technique was variable among inspectors and vulnerable to omission, it would help ensure that major areas of the hub were not missed. However, it is possible that the inspector examined the aft-face of the hub but did not look at the specific area containing the indication near the tierod hole.

Interruption is an inherent part of the FPI process, and the inspector would have interrupted his visual search several times to conduct diagnostic evaluations on detected indications and to reposition the hub. It is possible that the inspector failed to resume his search at the last location examined and that he was not aware of this because of the size and complexity of the part.⁹⁰ In studies of airframe inspectors, some have failed to detect defects because they did not resume their inspection at the appropriate location after stopping to move equipment.

It is also possible that the inspector detected an indication at the location of the crack but forgot to diagnose, or reinspect, the location. If inspectors had a method to document examined areas and locations requiring followup diagnosis, the inspector's dependency on memory would be reduced. A system in which an inspector could insert plastic markers into holes that have been inspected and found to be defect-free would serve as a mechanical checklist for the inspector, and document the progress of the inspection across the part. Such a system would also reduce the opportunity for human error in other procedural inspections, such as eddy current inspections of rivets or holes.

In sum, NDT inspections of critical rotating parts for small flaws are vulnerable to error in visual search and are dependent on the inspector's memory to ensure that an exhaustive

⁸⁸The brilliance of an indication is affected by the crack size and amount of penetrant in the defect. As discussed in section 2.4.1, dye penetrant contamination in the work area, processing errors, and methods used to handle and move hubs during the FPI process can also decrease the brilliance of an indication and can affect the inspector's ability to detect a crack.

⁸⁹Department of Transportation. 1996. *Visual Inspection Research Project Report on Benchmark Inspections. Final Report, October 1996*. DOT/FAA/AR-96/95. Washington, DC. This research group advocated development of NDI reliability models that acknowledge a background miss rate unrelated to crack length to more accurately model the observed data.

⁹⁰It is also possible that the glare associated with the use of white light to diagnose indications contributed to this omission because this process caused his eyes to lose dark adaptation.

search and adequate followup has been conducted. Accordingly, the Safety Board concludes that an inadvertent failure of the inspector to systematically search and complete followup diagnosis when necessary on all surfaces of the hub might have caused the inspector to overlook the crack. Therefore, the Safety Board believes that the FAA should require the development of methods for inspectors to note on the part or otherwise document during an NDT inspection the portions of a critical rotating part that have already been inspected and received diagnostic followup to ensure the complete inspection of the part.

2.4.2.2 Low Expectation of Finding a Crack and Decreased Vigilance

FPI inspectors are required to diagnose each detected indication to determine if it is a crack because a crack is reason to reject the part. But not every indication is a crack, and most preliminary indications are later found not to be cracks. The inspector who inspected the accident hub stated that he could not recall ever having detected a crack on a -219 hub, and the inspector's supervisor stated that he was not aware that cracks had ever been found on a -219 hub at Delta. Therefore, the inspector's experience diagnosing indications on -219 hubs consisted of a series of false indications. Although the inspector stated that he approached a part as if it had a crack to detect, his experience with indications on -219 hubs most likely biased his expectation of confirming that an indication was a crack, especially if the indication was not clearly defined.

Therefore, the Safety Board concludes that a low expectation of finding a crack in a -219 series fan hub might have caused the inspector to overlook or minimize the significance of an indication.

A low expectation of finding a crack might also have decreased the inspector's vigilance. Further, research on vigilance suggests that performance decreases with increasing inspection time.⁹¹ However, data to support this conclusion in the aviation inspection domain are inconclusive. In addition, a recent study of eddy current inspections of airframe skin panels found no relationship between inspection duration and probability of defect detection.⁹² In any event, no evidence from this investigation exists to evaluate how inspection duration and the adequacy of breaks (the inspector stated he took frequent breaks) affected the inspection of the accident hub. The inspector who inspected the accident hub characterized the FPI process as tedious and monotonous and stated that he spent about 75 percent of his shift inspecting parts. He also stated that inspection of a -219 hub typically took about 40 minutes to 2 hours, depending on the number of indications detected.

The Safety Board concludes that the duration of inspections and the amount and duration of rest periods may indeed affect inspector performance, but this potential has not been adequately studied in the aviation domain. Therefore, the Safety Board believes that the FAA

⁹¹ Drury, C. G. 1992. *Inspection Performance, Handbook of Industrial Engineering*. New York.

⁹² Department of Transportation. 1992. *Reliability Assessment at Airline Inspection Facilities, Volume III: Results of an Eddy Current Inspection Reliability Experiment*. May 1995. *Final Report*. DOT/FAA/CT-92/12, III. Washington, DC.

should conduct research to determine the optimum amount of time an inspector can perform NDT inspections before human performance decrements can be expected.

2.4.2.3 Inadequate Diagnostic Techniques or Controls

It is also possible that the inspector detected an indication at the location of the crack but did not properly complete the followup diagnostic procedure. Diagnostic procedures must be consistently performed and the appropriate time periods must be allowed for redevelopment to ensure that a true defect is not allowed to pass. Delta's Process Standard for conducting FPIs directed inspectors to wait at least 5 minutes to confirm that an indication had not reappeared after developer was applied during the bleed out procedure. As discussed above, there was no formal method for the inspectors to track these indications and to ensure that they were reinspected after the required redevelopment period. Further, as discussed in section 2.4.1, no formal method was in place to ensure adherence to the redevelopment time period. The Safety Board anticipates that in establishing the uniform set of standards (recommended in section 2.4.1), the FAA will recognize the need for a formal system for measuring and recording development times listed in its process standards for FPI.

2.4.2.4 Adequacy of Inspector Training and Proficiency

The Safety Board addressed the issue of NDT inspector training in a previous accident investigation of an uncontained engine failure.⁹³ In that accident, the Safety Board concluded that a 1/2-inch crack was present during the last inspection of the disk that would have been detected if proper MPI methods had been applied. The Safety Board noted that inspectors at the engine's repair station had trained each other and that the manufacturer had recommended that the repair station develop a formal initial and recurrent training program. In contrast, the Delta FPI inspector had completed a formal training program that included written and practical examinations and his training was consistent with industry standards. However, because this accident revealed that a crack was not detected at a repair facility that followed industry guidance, the Safety Board issued Safety Recommendation A-96-77 on July 29, 1996, asking the FAA to

Review and revise, in conjunction with the engine manufacturers and air carriers, the procedures, training (including syllabi and visual aids) and supervision provided to inspectors for performing FPI and other nondestructive testing of high-energy rotating engine parts, with particular emphasis on the JT8D-200 series tierod and stress redistribution holes.

The Safety Board classified this recommendation "Open—Acceptable Response" in February 1997, pending final FAA action after the FAA stated that it had inspected Delta's FPI

⁹³ National Transportation Safety Board. 1996. *Uncontained Engine Failure/Fire, ValuJet Airlines Flight 597, Douglas DC-9-32, N908VJ, Atlanta, Georgia, June 8, 1995*. Aircraft Accident Report NTSB/AAR-96/03. Washington, DC.

facility and concluded that the airline "had the proper guidance for training and qualifying personnel" in NDT and FPI. The Safety Board's decision was also based on FAA plans to have its FPI Review Team visit six FPI facilities, at a rate of two facilities per month. The team included representatives from the FAA's Engine and Propeller Directorate, Aircraft Certification Service, Aircraft Evaluation Group, and Certificate Management Office, with an NDT National Resource Specialist. These facilities were to include two major airlines, two engine manufacturer repair facilities, one airline contract repair facility, and one major repair station. After the inspections, the FAA stated that it would issue a report and determine what course of action, if any, needed to be taken. The FAA stated that it would also evaluate other facilities that perform FPI and other NDT procedures to determine whether systemic problems exist. The FAA has completed these inspections, but the report has not yet been issued.

A human factors expert testified at the public hearing on this accident that methods have been identified to augment training in inspection. These methods include incremental guidance for specific inspection skills and feedback guidance to inspectors during training. As the FAA completes action on A-96-77, the Safety Board anticipates that the FAA will consider these methods to improve inspector performance.

After the FAA's August 1996 review of Delta's FPI facility, the FAA recommended that written and proficiency examinations be required during inspector recertification. Delta responded to the recommendation by requiring that inspectors pass a written examination on FPI procedural knowledge and receive training to proficiency on a practical examination on a set of 10 sample parts. The Safety Board agrees with the FAA that additional and more frequent evaluation of inspectors is needed to ensure that inspectors are qualified to do their job. Written examinations provide information about an inspector's knowledge of the inspection process and procedures. Proficiency examinations like the one administered at Delta determine whether the inspector can apply the inspection procedures and interpret the results using a limited set of test pieces or actual parts. However, the effectiveness of an inspection involving visual search, like FPI, depends on the inspector's skills in visual search and detection, which cannot be adequately evaluated using written exams and practical tests that do not evaluate the ability of an inspector to detect indications using a sample of representative parts with and without defects. It would be beneficial to evaluate the inspector's skills to detect defects on the line; however, because defects that are missed on actual parts can go undetected, important feedback information required to determine inspector sensitivity is not available.

The Safety Board concludes that because of the potentially catastrophic consequences of a missed crack in a critical rotating part, testing methods that evaluate inspector capabilities in visual search and detection and document their sensitivity to detecting defects on representative parts are necessary. Such methods would require an inspector to examine several parts, some containing defects and some without, that are representative of those tested on the line. In addition, the defects provided should range in size from small at the threshold for the inspection method to large and well within the method's capabilities. A test of this type would provide an indication on the capabilities of the inspector unlike practical tests on only a few samples or that involve training to proficiency. Further, it would facilitate a comparison of how

different inspectors perform and if administered on a frequent basis provide a way to track inspector performance and focus recurrent training. Therefore, the Safety Board believes that the FAA should, in conjunction with industry and human factors experts, develop test methods that can evaluate inspector skill in visual search and detection across a representative range of test pieces, and ensure proficiency examinations incorporate these methods and are administered during initial and recurrent training for inspectors working on critical rotating parts.

Because FPI is dependent on several individuals performing multiple procedures, no single reason for the nondetection of the crack in this accident could be identified. The Safety Board concludes that Delta's nondetection of the crack was caused either by a failure of the cleaning and FPI processing, a failure of the inspector to detect the crack, or some combination of these factors.

2.5 Adequacy of Inspection Requirements for Critical Rotating Titanium Components

The Safety Board issued comprehensive recommendations following the July 19, 1989, United Airlines accident in Sioux City, Iowa, in which an in-flight uncontained engine failure led to the loss of the three hydraulic systems that powered the airplane's flight controls. The investigation found that fatigue cracking in the front fan disk originated in a hard alpha inclusion that had formed during the casting of the disk material. Included in the recommendations were Safety Recommendations A-90-89 and -90, which asked the FAA to develop a damage tolerance inspection program for all engine components that, if they failed or separated, posed a significant threat to the structures and systems of airplanes (see section 1.18.7). In response, the FAA formed the TRCRT to assess the quality control procedures used in the manufacture of titanium alloy high-energy rotating components of turbine engines.

The December 1990 TRCRT final report made several recommendations related to in-service inspections of titanium rotating parts, including using eddy current inspections to supplement FPIs and a requirement to subject such parts to at least two "subsurface inspections" (e.g., ultrasonic) during their cyclic life (see section 1.18.9). However, the implementation schedule for recommendations contained in the TRCRT report was canceled by the FAA following a 1991 industry conference during which industry representatives requested that the schedule be modified. Based on an April 6, 1993, FAA letter to the Safety Board that stated that future action would be taken to "develop implementation schedules commensurate with the needs of the FAA, industry, and the flying public," the Safety Board classified both safety recommendations "Closed—Acceptable Alternate Action" on May 28, 1993. The Safety Board is disappointed that no new schedules were developed and that no further action was taken by the FAA to implement the recommendations in the TRCRT report.

In addition to this accident, several other uncontained engine failures occurred after the Sioux City accident and the TRCRT report because of fatigue cracking that initiated

from various sorts of microstructural conditions created at manufacture.⁹⁴ Further, there was also evidence of manufacturing defects in several engines that failed before the Sioux City accident.⁹⁵ This accident history demonstrates that a variety of manufacturing anomalies in a variety of locations on engine parts can lead to uncontained failures, and that manufacturing defects are not as rare as might once have been believed. Further, given the loss of life that has resulted from the Sioux City and Pensacola failures, it is also clear that such defects can pose a significant threat to safety.

Most, if not all, of these engine parts were, at the time of manufacture, subjected to one or more nondestructive inspection techniques (such as an etch, ultrasonic inspection, or FPI) designed to detect manufacturing-related flaws and anomalies that might lead to cracking. (Some of the etch and ultrasonic inspections were performed on the rectilinear part [machine forged shape], and not on the final shape,⁹⁶ a practice that is no longer being used.) However, none of the flaws and anomalies that existed in those parts were detected, and the parts passed inspection. This demonstrates that the inspection methods used at manufacture can be fallible, and that newly manufactured engine parts may be placed into service containing potentially dangerous flaws.

Further, many of the flawed engine parts were subjected to in-service FPI or ultrasonic inspections after they developed cracks that had propagated to detectable lengths, yet they were not removed from service.⁹⁷ Thus, it is clear that detectable cracks in critical rotating engine parts may escape detection, even though the part has undergone in-service nondestructive testing techniques such as FPI. This point is further demonstrated by the ValuJet uncontained engine failure in Atlanta which, although it did not involve a manufacturing defect, again shows that a critical rotating part with a detectable crack can successfully pass through an NDT process (in that case MPI) and be placed back into service. Probability of detection data confirm that, even assuming the FPI procedures are properly executed, some detectable cracks will be missed. However, as discussed in sections 2.4.1 and 2.4.2, because FPI procedures may not always be

⁹⁴ A 1993 failure of the HPC stage 3-9 spool in a CF6-80C2 in Los Angeles, California, was attributed to dwell time fatigue initiating an area of aligned alpha colonies in the titanium alloy; a 1995 failure of an Egypt Air CF6-50C2 engine was attributed to a crack originating at a hard alpha inclusion in stage 6 of the HPC 3-9 stage spool; a 1995 failure of a CF6-50C2B engine in Bangkok, Thailand, was also attributed to dwell time fatigue resulting from aligned alpha colonies in the disc bore of the 3-9 HPC; and evidence from a 1997 failure of a Canadian Airlines CF6-80C2B6F engine, which is still under investigation, has revealed a microstructural anomaly in the blade slot bottom of the 3rd-stage HPC 3-9 stage spool.

⁹⁵ The 1982 failure of a Pan Am JT8D-7 engine was attributed to a crack originating in altered microstructure in a tierod hole, and three CF6 engine failures occurring in 1974, 1979, and 1983 were attributed to cracking originating in hard alpha inclusions.

⁹⁶ For example, the parts involved in the Sioux City, Egypt Air, and Canadian Airlines accidents were etched only in their rectilinear shape and were subjected to FPI in their final shape.

⁹⁷ In addition to the fan hub involved in this accident, the parts involved in the 1989 Sioux City, 1995 Egypt Air, 1982 Pan Am, 1995 Thailand, and 1997 Canadian Air accidents all underwent in-service FPI.

properly carried out, there are several additional reasons why a detectable crack might be missed during the FPI process.

The Safety Board concludes that manufacturing and in-service inspection processes currently being used do not provide sufficient redundancy to guarantee that newly manufactured critical rotating titanium engine parts will be put into service defect-free and will remain crack-free through the service life of the part. The Safety Board agrees with the TRCRT conclusion that

[based on the] frequency of occurrence of titanium metallurgical defects, the difficulty of detecting defects in titanium,...the many sources of defects, errors and damage, recent developments in the engineering science of fracture mechanics (crack propagation) analysis...the random approach of inspections of opportunity is not adequate, and can no longer be justified.

In light of the above, the Safety Board is especially concerned that the FAA's initial and recurring inspection program, as outlined in AD 97-02-11 and a subsequent final rule addressing the intent of Safety Recommendation A-96-74 (by taking into account the potential for microstructural defects produced by standard drills after a "major event such as tool breakage"), does not include mandatory or fixed-interval repetitive inspections for the remaining population of 2,272 fan hubs urged in Safety Recommendation A-96-75.

The Safety Board is concerned that JT8D-200 series fan hubs with more than 4,000 CSN may not receive FPI and eddy current inspections when these fan hubs are in the shop because there is no requirement to disassemble hubs to the piece-part level. In addition, AD 97-02-11 imposed no inspection requirement before retirement at 20,000 cycles in service (CIS) on fan hubs that have accumulated over 10,000 CIS before March 5, 1997, which constitutes a large percentage of all JT8D-200 series fan hubs. As such, AD 97-02-11 does not require the population of JT8D-200 series fan hubs with holes produced with standard drills or hubs with no machining or dimensional anomalies to be inspected unless the engine is disassembled to the piece-part level. This approach remains unacceptable.

However, the Safety Board's concern is not limited to JT8D-200 series fan hubs, but extends to all critical rotating titanium engine components. The Safety Board concludes that all critical rotating titanium engine components are susceptible to manufacturing flaws and resulting cracking and uncontained engine failures that could potentially lead to catastrophic accidents. Therefore, the Safety Board believes that the FAA should require that all heavy rotating titanium engine components (including the JT8D-200 series fan hubs) receive appropriate NDT inspections (multiple inspections, if needed) based on probability of detection data at intervals in the component's service life, such that if a crack exists, but is not detected during the first inspection, it will receive a second inspection before it can propagate to failure. In developing the inspection intervals, the Safety Board urges the FAA to assume that a crack may begin to propagate immediately after being put into service, as occurred in this accident and the United Airlines accident at Sioux City.

The Safety Board recognizes that all necessary probability of detection data and crack propagation rates may not be immediately available, and may have to be developed for some components. Therefore, the Safety Board believes that the FAA should require, as an interim measure, pending implementation of Safety Recommendation A-98-19, that critical rotating titanium engine components that have been in service for at least 2 years receive an FPI, eddy current, and ultrasonic inspection of the high-stress areas at the engine's next shop visit or within 2 years from the date of this recommendation, whichever occurs first.

These recommendations supersede Safety Recommendations A-96-74 and A-96-75, which the Safety Board now classifies "Closed—Unacceptable Action/Superseded."

2.6 Maintenance Deficiencies

During the preflight inspection the first officer found a small amount of oil on the bullet nose of the left engine and two rivets missing from the left wing. The oil that was found on the bullet nose could not have been related to the hub failure, and the missing rivets were from an outboard section of the wing. Therefore, the Safety Board concludes that these were not factors in the subsequent engine failure.

However, the Safety Board is concerned that the flightcrew did not request maintenance action before departure from Pensacola and that flightcrews may generally be reluctant to request maintenance at airports without company maintenance facilities because the reporting process and arranging for contract maintenance may result in delays. In this instance, the captain's deferral of a maintenance check of the oil leak until after arrival in Atlanta and his failure to ensure that maintenance action was taken on the missing rivets appear to have been contrary to guidance contained in Delta's FOM, which required flightcrews to notify Delta maintenance personnel of maintenance irregularities, or fluid leaks, at the gate. However, the flightcrew's decision was later supported by Delta management. This suggests that Delta management does not agree that fluid drops on the bullet nose or two missing rivets constitute maintenance irregularities.

Thus, the Safety Board concludes that there is a lack of clarity in written guidance in the FOM to Delta flightcrews on what constitutes maintenance "discrepancies" and "irregularities" and when to contact maintenance personnel and to log anomalies. Therefore, the Safety Board believes that the FAA should require Delta Air Lines to review its operational procedures, with special emphasis on nonmaintenance stations, to ensure that flightcrews have adequate guidance about what constitutes a maintenance irregularity or discrepancy (including the presence of fluid drops in unusual locations) before departure, and that following this review Delta should, contingent on FAA approval, amend its FOM to clarify under what circumstances flightcrews can, if at all, make independent determinations to depart when maintenance irregularities are noted. Further, the Safety Board is concerned that similar situations may be encountered by flightcrews at other airlines. Therefore, the Safety Board believes that the FAA should have its POIs review these policies and procedures at their respective operators to clarify, if necessary, these flightcrew responsibilities.

2.7 Crew Actions and Survival Factors

Immediately following the engine failure, the circumstances in the aft cabin were markedly different than those in the forward cabin. The aft flight attendants were presented with structural damage, serious injuries, and an engine fire, any one of which was sufficient to initiate an evacuation pursuant to Delta's policy and procedures. In contrast, the cockpit crew and forward flight attendant were unaware of these circumstances and, based on the absence of any indications of fire, the captain determined that an evacuation was not warranted. Unaware that passengers were evacuating, the captain did not shut down the engines until the first officer alerted him to do so after having walked through the cabin to assess the situation. However, based on the knowledge the captain had at the time, the Safety Board concludes that the captain shut down the engines in a timely manner when he became aware of conditions in the aft cabin.

The interphone system was inoperative at the critical moment when decisions were being made by the aft flight attendants to evacuate and by the captain not to evacuate. Thus, neither of these decisions, nor the information on which they were based, could be immediately communicated to crewmembers at the opposite end of the airplane. By the time emergency electrical power was restored to the interphone and the first officer again attempted to contact the aft flight attendants, the flight attendants were no longer in a position to, and would not have been expected to, respond to calls over the interphone because they were carrying out the evacuation and attending to injured passengers.

The Safety Board concludes that neither the aft flight attendants' decision to evacuate nor the captain's decision not to evacuate was improper in light of the information each of them had available at the time. However, the Safety Board is troubled by the lack of communication among crewmembers in the front and back of the airplane. Specifically, the Safety Board is concerned that crewmembers in the cockpit were unaware that emergency conditions existed and an evacuation was ongoing in the rear of their airplane. Even if this information would not have affected the captain's determination not to evacuate the entire airplane, at the very least it likely would have prompted him to immediately shut down the engines to minimize the hazards to those passengers who were evacuating.

The Safety Board has long been concerned about the difficulties that can arise when normal means of communication (interphone and/or PA systems) become unavailable during an emergency situation, when they generally are most needed. (See section 1.15.3.) Evacuation decisions, which must often be made very quickly, should be based on the most complete information possible about the condition of the airplane and possible hazards. As noted in the Tower Air accident report,⁹⁸ "positive communications are essential to coordinate the crew's response, even if the decision is not to evacuate."

⁹⁸Op. Cit. Footnote 38 (NTSB/AAR-96/04, page 47).

In 1972 and 1981 the Safety Board recommended that the FAA require independently powered evacuation alarm systems. However, at that time, the FAA determined that the cost of installing such alarm systems "would far outweigh any identifiable safety benefits." Thus, in most airplanes today, if there is a loss of airplane electrical power, crewmembers and passengers in one part of the airplane may not be aware of an evacuation that is occurring in another part of the airplane. Because a decision to evacuate generally indicates that there may be a hazard to passengers if they remain on board, the Safety Board remains concerned that the lack of an independently powered evacuation alarm system on most airplanes is a significant safety deficiency that should be corrected.

The Safety Board concludes that every passenger-carrying airplane operating under 14 CFR Part 121 should have a reliable means to ensure that all crewmembers on board the airplane are immediately made aware of a decision to initiate an evacuation. Therefore, the Safety Board believes that the FAA should require that all newly manufactured passenger-carrying airplanes operated under 14 CFR Part 121 be equipped with independently powered evacuation alarm systems operable from each crewmember station. The FAA should also require carriers operating airplanes so equipped to establish procedures, and provide training to flight and cabin crews, regarding the use of such systems. The issue of retrofitting existing airplanes with such systems will be addressed in the Safety Board's upcoming evacuation study.

As illustrated in this accident, emergency exits are sometimes opened by passengers before any evacuation order has been given or any decision has been reached. It is important for cockpit crews to know that exits have been opened for any reason so that appropriate measures can be taken to minimize the resulting potential hazards to passengers who may be departing the airplane through those exits. The Safety Board is aware that some airplanes, including the MD-88, are equipped with cockpit indicators showing open exits, but the Safety Board concludes that safety could be enhanced if all cockpit crews were immediately made aware of when exits are opened during an emergency. Therefore, the Safety Board believes that the FAA should require that all newly manufactured airplanes be equipped with cockpit indicators showing open exits, including overwing exit hatches, and that these cockpit indicators be connected to emergency power circuits. The issue of retrofitting existing airplanes will be addressed in the Safety Board's upcoming evacuation study.

Finally, the Safety Board is concerned that the overwing exits were opened while the airplane was still moving. The passenger who opened that exit told Safety Board investigators that he was uncertain whether he should open the exit and wished that he had received some guidance as to when it should be opened. The "Passenger Safety Information" card made available to each passenger on the Delta MD-88 illustrates how to open the exits, and states that persons seated in emergency exit seats must be able to "[a]ssess whether opening the emergency exit will increase the hazards to which passengers may be exposed." However, the card does not specifically state when the exit should be opened or describe the conditions under which doing so might increase the hazards to which passengers might be exposed. Nor does the card state that the exit should not be opened until the airplane has come to a stop. The Safety Board concludes that the guidance provided to passengers on Delta Air Lines MD-88s regarding when emergency exits should and should not be opened is not sufficiently specific. The Safety

Board is also concerned that guidance provided by other airlines on other airplanes might be similarly vague. The Board will address this issue further in its upcoming evacuation study.

3. CONCLUSIONS

3.1

Findings

1. The flightcrew was properly certified and trained for the flight, and was in compliance with Federal flight and duty time regulations.
2. The airplane was properly certificated and maintained in accordance with applicable Federal regulations, including a Federal Aviation Administration-approved airworthiness maintenance program.
3. Visual meteorological conditions prevailed, and weather was not a factor in the accident.
4. The oil observed preflight by the first officer came from the No. 1 bearing housing and, therefore, was not a precursor to the accident.
5. Some form of drill breakage or drill breakdown, combined with localized loss of coolant and chip packing, occurred during the drilling process, creating the altered microstructure and ladder cracking in the accident fan hub.
6. Fatigue cracks initiated from the ladder cracking in the tierod hole and began propagating almost immediately after the hub was put into service in 1990.
7. Although the altered microstructure in the accident hub tierod hole was detectable by blue etch anodize inspection methods, Volvo did not identify it as rejectable because the appearance of the tierod hole did not match any of the existing inspection templates showing rejectable conditions.
8. Although the additional templates will assist blue etch anodize inspectors in detecting potential defects similar to the one that existed on the accident hub, this accident suggests that there may be additional rejectable conditions that have not yet been identified.
9. Drilling damage in this accident hub extended much deeper into hole sidewall material than previously anticipated by Pratt & Whitney.
10. The crack was large enough to have been detectable during the accident hub's last fluorescent penetrant inspection at Delta.
11. Significant questions exist about the reliability of flash drying in removing water from cracks.

12. Better techniques are needed to ensure the fullest possible coverage of dry developer powder, particularly along hole walls.
13. Although it could not be conclusively determined whether this played a role in the nondetection of the crack in the accident hub, the absence of a system that formally tracks the timing of the movement of parts through the fluorescent penetrant inspection process was a significant deficiency.
14. Fluorescent penetrant inspection indications remain vulnerable to manual handling, and fixtures used to support the part during inspection may obstruct inspector access to areas of the part.
15. One or more procedural deficiencies in the cleaning, drying, processing, and handling of the part might have reduced or prevented the effectiveness of Delta's fluorescent penetrant inspection process in revealing the crack.
16. The potential deficiencies identified in the Delta fluorescent penetrant inspection process may exist at other maintenance facilities and be, in part, the reason for the failure to detect cracks in other failed engines identified in this investigation.
17. No personal or physical factors would have prevented the FPI inspector from detecting a visible crack in the accident hub.
18. An inadvertent failure of the inspector to systematically search and complete followup diagnosis when necessary on all surfaces of the hub might have caused the FPI inspector to overlook the crack.
19. A low expectation of finding a crack in a -219 series fan hub might have caused the FPI inspector to overlook or minimize the significance of an indication.
20. The duration of inspections and the amount and duration of rest periods may indeed affect inspector performance, but this potential has not been adequately studied in the aviation domain.
21. Because of the potentially catastrophic consequences of a missed crack in a critical rotating part, testing methods that evaluate inspector capabilities in visual search and detection and document their sensitivity to detecting defects on representative parts are necessary.

22. Delta's nondetection of the crack was caused either by a failure of the cleaning and fluorescent penetrant inspection processing, a failure of the inspector to detect the crack, or some combination of these factors.
23. Manufacturing and in-service inspection processes currently being used do not provide sufficient redundancy to guarantee that newly manufactured critical rotating titanium engine parts will be put into service defect-free and will remain crack-free through the service life of the part. Further, all critical rotating titanium engine components are susceptible to manufacturing flaws and resulting cracking and uncontained engine failures that could potentially lead to catastrophic accidents.
24. Although during the preflight inspection the first officer found a small amount of oil on the bullet nose of the left engine and two missing rivets, these were not factors in the subsequent engine failure.
25. There is a lack of clarity in written guidance in the flight operations manual to Delta flightcrews on what constitutes maintenance "discrepancies" and "irregularities" and when to contact maintenance personnel and to log anomalies.
26. The captain shut down the engines in a timely manner when he became aware of conditions in the aft cabin.
27. Neither the aft flight attendants' decision to evacuate nor the captain's decision not to evacuate was improper in light of the information each of them had available at the time.
28. Every passenger-carrying airplane operating under 14 Code of Federal Regulations Part 121 should have a reliable means to ensure that all crewmembers on board the airplane are immediately made aware of a decision to initiate an evacuation.
29. Safety could be enhanced if all cockpit crews were immediately made aware of when exits are opened during an emergency.
30. Guidance provided to passengers on Delta Air Lines MD-88s regarding when emergency exits should and should not be opened is not sufficiently specific.

3.2 Probable Cause

The National Transportation Safety Board determines that the probable cause of this accident was the fracture of the left engine's front compressor fan hub, which resulted from the failure of Delta Air Lines' fluorescent penetrant inspection process to detect a detectable fatigue crack initiating from an area of altered microstructure that was created during the drilling process by Volvo for Pratt & Whitney and that went undetected at the time of manufacture. Contributing to the accident was the lack of sufficient redundancy in the in-service inspection program.

4. RECOMMENDATIONS

As a result of the investigation of this accident, the National Transportation Safety Board makes the following recommendations to the Federal Aviation Administration:

Form a task force to evaluate the limitations of the blue etch anodize and other postmanufacturing etch processes and develop ways to improve the likelihood that abnormal microstructure will be detected. (A-98-09)

Inform all manufacturers of titanium rotating engine components of the potential that current boring and honing specifications may not be sufficient to remove potential defects from holes and ask them to reevaluate their manufacturing specifications and procedures with this in mind. (A-98-10)

Establish and require adherence to a uniform set of standards for materials and procedures used in the cleaning, drying, processing, and handling of parts in the fluorescent penetrant inspection process. In establishing those standards, the FAA should do the following:

Review the efficacy of drying procedures for aqueously cleaned rotating engine parts being prepared for fluorescent penetrant inspections; (A-98-11)

Determine whether flash drying alone is a sufficiently reliable method; (A-98-12)

Address the need to ensure the fullest possible coverage of dry developer powder, particularly along hole walls; (A-98-13)

Address the need for a formal system to track and control development times; (A-98-14) and

Address the need for fixtures that minimize manual handling of the part without visually masking large surfaces of the part. (A-98-15)

Require the development of methods for inspectors to note on the part or otherwise document during a nondestructive inspection the portions of a critical rotating part that have already been inspected and received diagnostic followup to ensure the complete inspection of the part. (A-98-16)

Conduct research to determine the optimum amount of time an inspector can perform nondestructive testing inspections before human performance decrements can be expected. (A-98-17)

In conjunction with industry and human factors experts, develop test methods that can evaluate inspector skill in visual search and detection across a representative range of test pieces, and ensure proficiency examinations incorporate these methods and are administered during initial and recurrent training for inspectors working on critical rotating parts. (A-98-18)

Require that all heavy rotating titanium engine components (including the JT8D-200 series fan hubs) receive appropriate nondestructive testing inspections (multiple inspections, if needed) based on probability of detection data at intervals in the component's service life, such that if a crack exists, but is not detected during the first inspection, it will receive a second inspection before it can propagate to failure; assuming that a crack may begin to propagate immediately after being put into service, as it did in the July 6, 1996, accident at Pensacola, Florida, and in the July 19, 1989, United Airlines accident at Sioux City, Iowa. (A-98-19)

Require, as an interim measure, pending implementation of Safety Recommendation A-98-19, that critical rotating titanium engine components that have been in service for at least 2 years receive a fluorescent penetrant inspection, eddy current, and ultrasonic inspection of the high-stress areas at the engine's next shop visit or within 2 years from the date of this recommendation, whichever occurs first. (A-98-20)

Require Delta Air Lines to review its operational procedures, with special emphasis on nonmaintenance stations, to ensure that flightcrews have adequate guidance about what constitutes a maintenance irregularity or discrepancy (including the presence of fluid drops in unusual locations) before departure, and that following this review Delta should, contingent on FAA approval, amend its flight operations manual to clarify under what circumstances flightcrews can, if at all, make independent determinations to depart when maintenance irregularities are noted. Further, the FAA should have its principal operations inspectors review these policies and procedures at their respective operators to clarify, if necessary, these flightcrew responsibilities. (A-98-21)

Require that all newly manufactured passenger-carrying airplanes operated under 14 Code of Federal Regulations Part 121 be equipped with independently powered evacuation alarm systems operable from each crewmember station, and establish procedures and provide training to flight and cabin crews regarding the use of such systems. (A-98-22)

Require that all newly manufactured airplanes be equipped with cockpit indicators showing open exits, including overwing exit hatches, and that

these cockpit indicators be connected to emergency power circuits.
(A-98-23)

BY THE NATIONAL TRANSPORTATION SAFETY BOARD

JAMES E. HALL
Chairman

ROBERT T. FRANCIS
Vice Chairman

JOHN HAMMERSCHMIDT
Member

JOHN J. GOGLIA
Member

GEORGE W. BLACK, JR.
Member

January 13, 1998

5. APPENDIXES

APPENDIX A—INVESTIGATION AND HEARING

1. Investigation

The National Transportation Safety Board was initially notified of this accident about 1545 EDT on July 6, 1996, by the FAA. A Washington, D.C.-based team arrived at the scene at 2300 the same day. The team comprised investigative groups in the areas of powerplants, aircraft systems and structures, maintenance records, metallurgy, operations, human performance and survival factors. Safety Board Member George Black accompanied the investigative team.

Parties to the investigation were the FAA, Delta Air Lines, McDonnell Douglas, Pratt & Whitney, Air Line Pilots Association, and Pensacola Regional Airport.

2. Public Hearing

A public hearing on this accident was held in Atlanta, Georgia, from March 26 through March 28, 1997. Seventeen witnesses testified during the hearing. Member John Goglia was the presiding officer.

APPENDIX B—COCKPIT VOICE RECORDER TRANSCRIPT

LEGEND

CAM	Cockpit area microphone
HOT	Crewmember hot microphones
-1	Voice (or position) identified as Captain
-2	Voice (or position) identified as First Officer
-3	Voice (or position) identified as Jump Seat rider
-4	Voice identified as first Flight Attendant
-5	Unidentified female voice
-6	Voice identified as second Flight Attendant
-?	Unidentifiable voice
PENGND	Pensacola Ground Control
GNDCRW	Pensacola Ground Crew
TWR	Local Tower Control
PA	Aircraft public address system
*	Unintelligible word
#	Expletive deleted
...	Pause
()	Questionable text
[]	Editorial insertion
-	Break in continuity

INTRA-COCKPIT COMMUNICATION

AIR-GROUND COMMUNICATION

TIME and
SOURCE

TIME and
SOURCE

CONTENT

CONTENT

1505:11
CAM-2
there's oil coming out of the bullet now.

1505:13
CAM-1
what?

1505:14
CAM-2
oil, very little ... but I've never noticed it before.

1505:20
CAM-1
just a drip, kind of wet?

1505:21
CAM-2
yeah, you know, but you can tell that it ah, you know * * * *, it wasn't pouring.

1505:31
CAM-2
I've never, I've never noticed that before.

1505:33
CAM-1
but there shouldn't be any oil in the bullet.

1505:34
CAM-2
I figure it must be coming through that ah engine anti-ice, right. * * * doesn't it, it goes through the that cowing on the bullet.

1505:43
CAM-1
* that's bleed air.

1505:45
CAM-2
so where's the N1 and where's the oil coming from?

INTRA-COCKPIT COMMUNICATION

AIR-GROUND COMMUNICATION

<u>TIME and SOURCE</u>	<u>CONTENT</u>	<u>TIME and SOURCE</u>	<u>CONTENT</u>
1505:48 CAM-?	no idea.		
1505:51 CAM-?	if I knew I'd tell yah.		
1505:57 CAM-2	when we yah know get in there I mean, I don't think it's anything worth worrying about.		
1506:01 CAM-1	yeah we'll do that.		
1506:06 CAM-2	and ah there's two rivets on the left leading edge of that um that stat ... * * * .		
1506:16 CAM-?	.		
1506:24 CAM-1	two rivets missing ... put it in the book.		
1506:26 CAM-2	do you want to get it now or do you want me to -		
1506:27 CAM-1	um -		
1506:28 CAM-2	just give 'em a call on the way in.		
1506:29 CAM-1	those are the kind of things we should do it now.		

INTRA-COCKPIT COMMUNICATION

AIR-GROUND COMMUNICATION

TIME and SOURCE

CONTENT

CONTENT

1506:31 CAM-?	you'll be - when we get there.
1506:40 CAM-2	... brake pedal ... their guy fixed it right then and there.
1506:46 CAM-1	huh?
1506:46 CAM-2	they're gonna fix it right then right there.
1506:56 CAM-?	you sure you don't wanna go out on a boat today?
1507:01 CAM-?	..
1507:03 CAM-?	we might be able to work in eighteen holes of golf too.
1507:06 CAM-?	... parkway (I don't blame you).
1507:10 CAM-?	(don't) drink my beer.
1507:11 CAM-?	ah man, now you're getting restrictive.
1507:13 CAM	[sound of laughter]
1507:15 CAM	[sound of stabilizer trim-in-motion signal]

INTRA-COCKPIT COMMUNICATION

AIR-GROUND COMMUNICATION

<u>TIME and SOURCE</u>	<u>CONTENT</u>	<u>TIME and SOURCE</u>	<u>CONTENT</u>
1507:16 CAM	[sound of cabin chime]		
1507:18 CAM-?	I like this idea, by the way.		
1507:15 CAM-?	do yah.		
1507:20 CAM-?	yeah.		
1507:22 CAM	[twenty seconds of unintelligible conversation]		
1507:41 CAM-1	I take it you've done all this before, sit on this jump seat on this airplane and all that?		
1507:46 CAM-3	last time I saw a jump seat was a DC-9 so I assume they work pretty much the same way.		
1507:51 CAM-1	yeah we got the squeeze mask -		
1507:52 CAM-3	squeeze mask .. I saw that just pull it.		
1507:54 CAM-1	same as the nine, go out the window (or aft stairs).		
1507:56 CAM-3	yeah.		

INTRA-COCKPIT COMMUNICATION

AIR-GROUND COMMUNICATION

TIME and SOURCE

CONTENT

TIME and SOURCE

CONTENT

1507:58 CAM-1 anything up there on that yellow placard.

1508:06 CAM-1 your choice, we'll try to keep the speaker up.

1508:08 CAM-3 ah I don't care.

1508:10 CAM-1 well, if you help us listen and watch we'd appreciate it ... it'll be another set of eyes up here, might as well use them.

1508:15 CAM-3 glad to do that.

1508:16 CAM-1 alright.

1508:15 RDO-2 * ground delta twelve eighty-eight atlanta with victor.

1508:31 PENGND twelve eighty-eight cleared atlanta as filed maintain three thousand expect flight level two niner zero one zero minutes after departure. departure frequency one one nine point zero. squawk three two two four.

1508:31 CAM-1 * how are you doing?

1508:32 CAM-4 fine, how are you doing?

INTRA-COCKPIT COMMUNICATION

AIR-GROUND COMMUNICATION

<u>TIME and SOURCE</u>	<u>CONTENT</u>	<u>TIME and SOURCE</u>	<u>CONTENT</u>
1508:33 CAM-1	good to see you.		
1508:34 CAM-4	good to see you too.		
1508:35 CAM-1	how's your mom doing?		
1508:36 CAM-4	hanging in there.		
1508:37 CAM-1	really?		
1508:37 CAM-4	yeah, hanging in there.		
1508:38 CAM-1	still down in tyrone?		
1508:40 CAM-4	yeah, yup.		
1508:41 CAM-1	when you gonna get her to move up?		
1508:43 CAM-4	well, we keep thinking about it, and looking into this, that and the other thing and she doesn't want to move into a rental house (out of the neighborhood [unintelligible])		

INTRA-COCKPIT COMMUNICATION

AIR-GROUND COMMUNICATION

TIME and SOURCE

CONTENT

TIME and SOURCE

CONTENT

1509:00
CAM-4

you know the bottom line is the whole situation [unintelligible]

1509:04
CAM-1

yeah.

1509:05
CAM-4

[sound of laughter] [unintelligible] we keep looking and thinking about it and every time she does she goes well maybe I won't.

1509:14
CAM-1

yeah. what do you do, where are you living now?

1509:27
CAM-1

where are you living now?

1509:27
CAM-4

same place. haven't moved anywhere.

1509:29
CAM-1

that's over there off of forty-one?

1508:43
RDO-2

delta twelve eighty eight atlanta as filed, three thousand's the hold down. twenty nine at ten nineteen zero and three two two four. any delays today?

1508:53
PENGND

negative.

1508:54
RDO-2

thank you

INTRA-COCKPIT COMMUNICATION

AIR-GROUND COMMUNICATION

<u>TIME and SOURCE</u>	<u>CONTENT</u>	<u>TIME and SOURCE</u>	<u>CONTENT</u>
1509:31 CAM-4	off south cobb.		
1509:32 CAM-1	south cobb.		
1509:32 CAM-4	yeah yeah.		
1509:33 CAM-1	so you're way over there in the boonies.		
1509:35 CAM-4	yeah yeah.		
1509:37 CAM	[unintelligible]		
1509:38 CAM-1	true. every road around me is torn up, every road.		
1509:42 CAM	[unintelligible passenger cabin background conversation]		
1509:57 CAM-4	we haven't gotten our (Agua) yet, do you want anything else?		
1510:01 CAM-1	geeze oh pete, I guess I'll just have to have airplane water.		
1510:04 CAM-4	oh no.		
1510:05 CAM-1	that's okay, I'll live with (this).		

INTRA-COCKPIT COMMUNICATION

AIR-GROUND COMMUNICATION

<u>TIME and SOURCE</u>	<u>CONTENT</u>
1510:07 CAM-4	can I get you anything?
1510:08 CAM-2	I'll sell you some, I'll sell you some.
1510:10 CAM-1	nah.

TIME and SOURCE

CONTENT

1510:11
GNDCRW ready captain?

1510:12
CAM-2 I'll split it with you.

1510:15
INT-1 yes sir.

1510:16
GNDCRW yes sir wings are clear. if I can get some hydraulics and if you would start your APU.

1510:20
INT-1 okay here comes the hydraulics .. APU's ah, we're turning it on now .. if you'd hold off on pulling the air for about a minute we'd appreciate it.

1510:27
GNDCRW yes sir no problem.

1510:31
HOT-2 um as filed, three thousand to hold down, twenty-nine at ten, nineteen nothing, three two two four.

INTRA-COCKPIT COMMUNICATIONAIR-GROUND COMMUNICATION

<u>TIME and SOURCE</u>	<u>CONTENT</u>	<u>TIME and SOURCE</u>	<u>CONTENT</u>
1510:41 CAM-1	where do you live?		
1510:42 CAM-3	dallas.		
1510:44 CAM	[sound of chime and CVR power interrupt]		
1510:45 CAM-7	deadheading on this or seeing a friend or - ?		
1510:52 CAM	[sound of cabin chime]		
1510:54 CAM-1	that's what I did on the layover, I have a friend down here .. retiree [unintelligible]		
1511:05 CAM-4	here's your water, * hot water.		
1511:08 CAM-7	thank you.		
1511:10 CAM-3	who is it john?		
1511:11 CAM-1	it's [nonpertinent name removed].		
1511:13 CAM-3	I don't know him.		

INTRA-COCKPIT COMMUNICATION

AIR-GROUND COMMUNICATION

TIME and
SOURCE

CONTENT

TIME and
SOURCE

CONTENT

1511:13
CAM-1

he married the atlanta chief pilot's secretary, who was [nonpertinent name removed] at the time.

1511:28
GNDCRW

captain just let me know whenever we can pull the ground power.

1511:31
INT-1

okay you can pull it.

1511:34
GNDCRW

thank you.

1511:36
CAM-1

let's read it.

1511:43
HOT-2

did they put any um cargo in that number one?

1511:47
CAM-1

yes (thirty thirty-five) pounds.

1511:50
HOT-2

because it was empty when I did the walk around.

1511:56
CAM-1

you say it was empty? * * * ... go ahead and read it.

1512:00
HOT-2

before start exterior interior pre-flight?

1512:02
CAM-1

complete.

INTRA-COCKPIT COMMUNICATIONAIR-GROUND COMMUNICATION

<u>TIME and SOURCE</u>	<u>CONTENT</u>	<u>TIME and SOURCE</u>	<u>CONTENT</u>
1512:01 HOT-2	log books checklist?		
1512:02 CAM-1	checked.		
1512:02 HOT-2	circuit breakers?		
1512:03 CAM-1	checked.		
1512:03 HOT-2	oxygen mask regulators interphones?		
1512:04 CAM-1	left.		
1512:04 HOT-2	right .. aft overhead?		
1512:07 CAM-1	checked.		
1512:08 HOT-2	CADC flight director EFIS switches?		
1512:09 CAM-1	normal.		
1512:10 HOT-2	voice recorder?		
1512:10 CAM-1	checked.		

INTRA-COCKPIT COMMUNICATIONAIR-GROUND COMMUNICATION

<u>TIME and SOURCE</u>	<u>CONTENT</u>	<u>TIME and SOURCE</u>	<u>CONTENT</u>
1512:11 HOT-2	electrical panel?		
1512:11 CAM-1	set.		
1512:11 HOT-2	battery switch?		
1512:12 CAM-1	on and locked.		
1512:13 HOT-2	emergency power?		
1512:13 CAM-1	off.		
1512:14 HOT-2	fuel tank pumps crossfeed?		
1512:15 HOT-1	checked and off.		
1512:15 HOT-2	ignition?		
1512:16 HOT-1	off.		
1512:16 HOT-2	emergency lights?		
1512:17 HOT-1	armed.		

INTRA-COCKPIT COMMUNICATIONAIR-GROUND COMMUNICATION

<u>TIME and SOURCE</u>	<u>CONTENT</u>	<u>TIME and SOURCE</u>	<u>CONTENT</u>
1512:17 HOT-2	no smoking seat belt lights?		
1512:18 HOT-1	on.		
1512:18 HOT-2	pitot heat?		
1512:18 HOT-1	on.		
1512:15 HOT-2	airfoil engine anti-ice?		
1512:15 HOT-1	off.		
1512:20 HOT-2	windshield anti-fog anti-ice?		
1512:20 HOT-1	off and on.		
1512:21 HOT-2	IRS mode selectors?		
1512:23 HOT-1	it's not required.		
1512:23 HOT-2	anti-skid?		
1512:24 HOT-1	armed.		

INTRA-COCKPIT COMMUNICATIONAIR-GROUND COMMUNICATION

<u>TIME and SOURCE</u>	<u>CONTENT</u>	<u>TIME and SOURCE</u>	<u>CONTENT</u>
1512:24 HOT-2	stall warning?		
1512:24 HOT-1	checked.		
1512:24 HOT-2	yaw damper?		
1512:25 HOT-1	on.		
1512:25 HOT-2	mach trim?		
1512:26 HOT-1	normal.		
1512:26 HOT-2	radio rack switch?		
1512:27 HOT-1	fan.		
1512:26 HOT-2	air conditioning?		
1512:27 HOT-1	set.		
1512:27 HOT-2	pressurization?		
1512:28 HOT-1	set.		

INTRA-COCKPIT COMMUNICATIONAIR-GROUND COMMUNICATION

<u>TIME and SOURCE</u>	<u>CONTENT</u>	<u>TIME and SOURCE</u>	<u>CONTENT</u>
1512:28 HOT-2	air conditioning auto shutoff?		
1512:29 HOT-1	auto.		
1512:29 HOT-2	ram air switch?		
1512:30 HOT-1	it's off.		
1512:31 HOT-2	annunciator panel digital lights?		
1512:31 HOT-1	recall checked.		
1512:32 HOT-2	exterior lights?		
1512:32 HOT-1	set.		
1512:33 HOT-2	NAV FGS panel?		
1512:33 HOT-1	check set.		
1512:34 HOT-2	altimeters flight instruments?		
1512:35 HOT-1	ah twenty-nine ninety-eight set.		

INTRA-COCKPIT COMMUNICATION

AIR-GROUND COMMUNICATION

<u>TIME and SOURCE</u>	<u>CONTENT</u>	<u>TIME and SOURCE</u>	<u>CONTENT</u>
1512:37 HOT-2	ah let's see two nine nine eight set .. cross checked .. ah fire warning?		
1512:43 HOT-1	checked.		
1512:44 HOT-2	art switch?		
1512:44 HOT-1	it's auto.		
1512:45 HOT-2	engine instruments?		
1512:45 HOT-1	checked.		
1512:46 HOT-2	fuel required?		
1512:49 CAM-5	it's full now .. I don't know if your passenger pre-board does not say it's full but it is full.		
1512:54 HOT-1	nineteen, we have eighteen nine minimum of eighteen five.		
1512:59 HOT-2	eighteen five eighteen nine, did you hear that?		
1513:01 HOT-1	what?		

INTRA-COCKPIT COMMUNICATIONAIR-GROUND COMMUNICATION

<u>TIME and SOURCE</u>	<u>CONTENT</u>	<u>TIME and SOURCE</u>	<u>CONTENT</u>
1513:01 HOT-2	her paperwork was wrong.		
1513:04 CAM-4	one (four) one thirty-eight (total cabin full).		
1513:06 HOT-2	fourteen one twenty-eight.		
1513:07 HOT-1	I got a hundred and forty-two.		
1513:08 HOT-2	ours is full. thanks for asking though.		
1513:12 HOT-2	fuel used counters?		
1513:13 HOT-1	reset.		
1513:14 HOT-2	brake temp?		
1513:14 HOT-1	checked all.		
1513:15 HOT-2	radar?		
1513:15 HOT-1	checked.		
1513:16 HOT-2	stabilizer trim?		

INTRA-COCKPIT COMMUNICATIONAIR-GROUND COMMUNICATION

<u>TIME and SOURCE</u>	<u>CONTENT</u>	<u>TIME and SOURCE</u>	<u>CONTENT</u>
1513:16 HOT-1	checked.		
1513:17 HOT-2	spoilers?		
1513:15 HOT-1	ah retract.		
1513:15 HOT-2	rudder control lever?		
1513:20 HOT-1	power.		
1513:20 HOT-2	throttles?		
1513:20 HOT-1	check idle.		
1513:21 HOT-2	outflow valve?		
1513:21 HOT-1	auto.		
1513:22 HOT-2	flaps slats?		
1513:22 HOT-1	up retract.		
1513:22 HOT-2	fuel levers?		

INTRA-COCKPIT COMMUNICATION

AIR-GROUND COMMUNICATION

<u>TIME and SOURCE</u>	<u>CONTENT</u>	<u>TIME and SOURCE</u>	<u>CONTENT</u>
1513:23 HOT-1	they're off.		
1513:24 HOT-2	radios transponder ACARS?		
1513:24 HOT-1	set.		
1513:25 HOT-2	stabilizer trim brake switch?		
1513:25 HOT-1	normal.		
1513:26 HOT-2	rudder aileron trim?		
1513:28 HOT-1	zero.		
1513:28 HOT-2	autobrakes?		
1513:28 HOT-1	zero disarm and off.		
1513:29 HOT-2	flight attendant briefing?		
1513:30 HOT-1	complete.		

AIR-GROUND COMMUNICATION

Page 21 of 35

INTRA-COCKPIT COMMUNICATION

<u>TIME and SOURCE</u>	<u>CONTENT</u>	<u>TIME and SOURCE</u>	<u>CONTENT</u>
1513:30 HOT-2	departure briefing .. WARTS weather's not a factor, abnormal's as you brief, runway will be one seven it's ah seven thousand feet we have RTO .. ah we're going to be relatively heavy you call it fill back you up .. terrain and SID climbing to three thousand feet normal speeds whatever heading they give us.		
1513:42 HOT-1	okay.		
1513:45 HOT-1	zero fuel weight is one twelve point four.		
1513:57 HOT-1	seventeen let's go full power.		
1513:59 HOT-2	okay.		
1514:01 HOT-1	ah one thirty-one one thirty-seven one forty-six .. one eighty-nine.		
1514:11 HOT-2	ah let's see one thirty-one.		
1514:12 HOT-1	two thirty-five.		
1514:13 HOT-2	two thirty-five .. one thirty-one one forty-six eighty-nine two thirty-five .. zero ah zero fuel weight?		

INTRA-COCKPIT COMMUNICATIONAIR-GROUND COMMUNICATION

<u>TIME and SOURCE</u>	<u>CONTENT</u>	<u>TIME and SOURCE</u>	<u>CONTENT</u>
1514:24 HOT-1	set.		
1514:24 HOT-2	FMS?		
1514:25 HOT-1	set.		
1514:25 HOT-2	takeoff condition computer?		
1514:27 HOT-1	it is ah sixteen point two and five point five degrees set.		
1514:29 CAM	[sound of trim-in-motion signal]		
1514:35 HOT-2	six point two flaps eleven five point five on the stabilizer ... flap takeoff selector?		
1514:39 HOT-1	set.		
1514:40 HOT-2	airspeed bugs TRIP?		
1514:42 HOT-1	they are ah one thirty-one one thirty-seven one forty-eight one eighty-nine two thirty-five full power one point nine five.		
1514:52 HOT-2	set on the right.		

INTRA-COCKPIT COMMUNICATIONAIR-GROUND COMMUNICATION

<u>TIME and SOURCE</u>	<u>CONTENT</u>	<u>TIME and SOURCE</u>	<u>CONTENT</u>
1515:01 HOT-2	before start checklist complete.		
1515:02 HOT-1	thank you.		
1515:04 HOT-2	no no thank you.		
1515:06 CAM-3	john do you mind if i go ahead and put this down they're full back there?		
1515:09 HOT-1	yeah go right ahead. do you know how to do it?		
1515:10 CAM-3	well i think it works the same way it used to.		
1515:12 HOT-1	yeah some things never change.		
1515:22 CAM	[sound of laughter]		
1515:29 CAM-3	sure had to make sure she got on.		
1515:30 HOT-1	uh - huh.		
1515:45 HOT-1	what are you flying over in dallas?		

INTRA-COCKPIT COMMUNICATIONAIR-GROUND COMMUNICATION

<u>TIME and SOURCE</u>	<u>CONTENT</u>	<u>TIME and SOURCE</u>	<u>CONTENT</u>
1515:46 CAM-3	seven six		
1515:48 HOT-1	good deal ... it's a tough job isn't it?		
1515:53 CAM-3	yup [unintelligible]		
1516:01 HOT-1	do yah .. what short legs .. up down?		
1516:04 CAM-3	I flew nine years on the thirty-seven. I flew six years on the DC nine as copilot.		
1516:09 HOT-1	yeah ... we're getting longer and longer legs on this ah. last trip we flew atlanta miami boston. the next day we went boston orlando back to boston. third day was our short day it was ah cincinnati indi atlanta.		
1516:27 CAM-3	dallas dallas they got ah they fly the ninety quite a bit out there and they have some pretty good legs.		
1516:31 HOT-1	yeah.		
1516:34 CAM-3	[unintelligible]		
1516:34 HOT-2	the ninety's gotten video on it though doesn't it?		

INTRA-COCKPIT COMMUNICATION

AIR-GROUND COMMUNICATION

<u>TIME and SOURCE</u>	<u>CONTENT</u>	<u>TIME and SOURCE</u>	<u>CONTENT</u>
1516:35 HOT-1	yeah ... entertainment.		
1516:41 CAM-3	[unintelligible]		
1516:45 HOT-2	oh yeah.		
1516:45 HOT-1	yeah.		
1516:47 CAM-3	[unintelligible]		
1516:51 HOT-1	you got that on the seven five too don't you?		
1516:57 CAM-6	everybody up here doing alright * * * .		
1517:07 CAM-6	cabin's ready for push back.		
1517:08 HOT-1	okay thank you.		
1517:27 CAM	[sound of two cabin chimes]	1517:26 INT-1	brakes released cleared to push.
		1517:28 GNDCRW	alright sir here we go.

INTRA-COCKPIT COMMUNICATION

AIR-GROUND COMMUNICATION

TIME and SOURCE

CONTENT

TIME and SOURCE

CONTENT

1517:33
HOT-1 pushback and start check list.

1517:35
HOT-2 it's ah -

1517:45
GNDCRW sir which runway will you be using?

1517:46
INT-1 ah one seven.

1517:57
GNDCRW alright captain you're clear to start your engines.

1517:59
INT-1 roger.

1518:09
HOT-2 don't have any rides from here to dallas huh .. any flights?

1518:13
CAM-3 (not direct).

1518:16
HOT-1 really, wonder why?

1518:15
CAM-3 better utilization of equipment, that's the company line.

1518:22
HOT-2 better utilization of the equipment that's true.

1518:25
HOT-1 then why weren't we utilizing them better in the first place?

INTRA-COCKPIT COMMUNICATION

AIR-GROUND COMMUNICATION

TIME and
SOURCE

TIME and
SOURCE

CONTENT

CONTENT

1518:28
CAM-3 every month they set a boarding record.

1518:31
HOT-1 ah I know it.

1518:34
CAM-3 they have two nonstops a day and ah one went through mobile.

1518:39
HOT-1 yeah, I've flown that one.

1518:40
CAM-3 they did the same thing in mobile. they have two nonstops through mobile and one more came on over here.

1518:47
HOT-2 I'll bet you the yield is low here .. vaca -

1518:50
HOT-1 I'd think it'd be real high here.

1518:51
HOT-2 isn't it all vacationers?

1518:52
HOT-1 yeah but the yield is high since there's no competition.

1518:58
HOT-2 hum.

1518:59
HOT-1 I mean there is some but not a whole lot.

INTRA-COCKPIT COMMUNICATION

AIR-GROUND COMMUNICATION

TIME and
SOURCE

CONTENT

TIME and
SOURCE

CONTENT

1515:24
HOT-1

fuel flow light off.

1515:34
HOT-2

start valve is closed.

1515:35
HOT-1

after start.

1515:37
CAM

[sound of cabin chime and power interruption to CVR]

1515:48
HOT-2

engine (ice).

1515:49
HOT-1

it's off not required.

1515:50
HOT-2

it's off .. left engines up it's above fifty, oil pressure's good, hydraulics good, pumps are on pushback start checklist complete.

1515:02
GNDCRW airight captain will you please set your brakes.

1515:05
INT-1 brakes set cleared to disconnect.

1515:07
GNDCRW airight sir you have a safe flight home.

1515:09
INT-1 see yah.

INTRA-COCKPIT COMMUNICATION

AIR-GROUND COMMUNICATION

TIME and
SOURCE

CONTENT

1515:56
HOT-1 thank you.

1520:16
HOT-2

clear on the right.

1520:20
CAM

[sound of several clicks]

1520:22
CAM

[sound of spoiler being armed]

1520:47
HOT-2

clear on the right.

1520:49
HOT-1

thank you.

1520:57
HOT-2

coming back.

TIME and
SOURCE

CONTENT

1520:00
RDO-2 delta twelve eighty-eight taxi please with victor.

1520:03
PENGND delta twelve eighty-eight [break in audio] two zero at one two altimeter two nine nine seven.

1520:09
RDO-2 and delta twelve eighty-eight you were cut out a little bit we understand two nine nine seven cleared to taxi to one seven.

1520:13
PENGND that is correct.

INTRA-COCKPIT COMMUNICATION

AIR-GROUND COMMUNICATION

<u>TIME and SOURCE</u>	<u>CONTENT</u>	<u>TIME and SOURCE</u>	<u>CONTENT</u>
1520:58 HOT-1	go ahead.		
1521:02 HOT-1	watch your feet.		
1521:03 HOT-2	clear.		
1521:07 HOT-2	spin it?		
1521:07 HOT-1	go ahead.		
1521:14 HOT-2	taxi?		
1521:15 HOT-1	go ahead.		
1521:16 HOT-2	taxi checklist flaps and slats are eleven eleven and takeoff, autobrakes and spoilers are armed takeoff armed airspeed bugs TRP set normal power no change since you went over it. allimeters?		
1521:26 HOT-1	twenty nine ninety seven now.		
1521:27 HOT-2	two nine nine seven set. flight NAV instruments?		
1521:29 HOT-1	set for departure.		

INTRA-COCKPIT COMMUNICATION

AIR-GROUND COMMUNICATION

<u>TIME and SOURCE</u>	<u>CONTENT</u>	<u>TIME and SOURCE</u>	<u>CONTENT</u>
------------------------	----------------	------------------------	----------------

1521:30 HOT-2	set and ah flight controls? i've got tops.		
------------------	--	--	--

1521:32 HOT-1	bottoms check.		
------------------	----------------	--	--

1521:33 HOT-2	taxi checklist is complete.		
------------------	-----------------------------	--	--

1521:37 HOT-2	flash.		
------------------	--------	--	--

1521:41 HOT-2	start valve closed.		
------------------	---------------------	--	--

1521:43 CAM	[sound of cabin chime]		
----------------	------------------------	--	--

1521:46 HOT-2	engine anti-ice?		
------------------	------------------	--	--

1521:48 HOT-1	it's off.		
------------------	-----------	--	--

1521:48 HOT-2	it's off .. both engines up ... coming above fifty. oil pressure's good. hydraulic pressure checks good. delayed start checklist complete.		
------------------	--	--	--

1521:55 HOT-1	thank you.		
------------------	------------	--	--

1521:59 HOT-2	nineteen nine.		
------------------	----------------	--	--

INTRA-COCKPIT COMMUNICATION

AIR-GROUND COMMUNICATION

TIME and
SOURCE

CONTENT

TIME and
SOURCE

CONTENT

1522:07
HOT-2 ready to go terry?

1522:10
CAM-6 yeah .. what .. what did you say?

1522:16
HOT-2 you guys ready?

1522:22
PA-2 good afternoon folks from the flight deck. we're currently number one for departure. if the flight attendants could please complete the cabin safety check we'll be airborne here momentarily. flight plan indicates a very brief forty minutes over to atlanta. we're expecting an on-time arrival. current atlanta weather has scattered conditions and ninety-five degrees. welcome aboard.

1522:37
HOT-2 was i close?

1522:38
HOT-1 somewhere around there.

1522:41
CAM-3 you really know how to read the METAR.

1522:42
HOT-2 thank you.

1522:50
HOT-1 you'll probably start seeing somebody's mimeograph cheat sheet somewhere in here like that.

INTRA-COCKPIT COMMUNICATION

AIR-GROUND COMMUNICATION

<u>TIME and SOURCE</u>	<u>CONTENT</u>	<u>TIME and SOURCE</u>	<u>CONTENT</u>
1522:55 HOT-2	yeah .. good idea.	1523:21 RDO-2	delta twelve eighty-eight's ready to go.
1523:15 CAM-6	ready for takeoff.	1523:23 TWR	twelve eighty-eight fly runway heading clear for takeoff.
1523:16 HOT-1	thanks.	1523:25 RDO-2	delta twelve eighty-eight cleared for takeoff runway one seven and runway heading.
1523:17 HOT-2	thanks terr.		
1523:30 HOT-2	runway heading. alright.		
1523:33 CAM	[sound of several clicks]		
1523:39 HOT-2	ah annunciator panel warning lights checked. flaps and slats?		
1523:42 HOT-1	eleven eleven takeoff.		

INTRA-COCKPIT COMMUNICATIONAIR-GROUND COMMUNICATION

<u>TIME and SOURCE</u>	<u>CONTENT</u>	<u>TIME and SOURCE</u>	<u>CONTENT</u>
1523:43 HOT-2	eleven eleven and takeoff. takeoff warning?		
1523:45 HOT-1	it's checked.		
1523:46 HOT-2	brake temp looks good. flight attendants notified and acknowledged. doors and windows closed and locked. takeoff briefing runway heading three thousand feet normal speed. runway's updated. got ignition, lights, transponder, TCAS. it's all done.		
1523:58 HOT-2	before taking off checklist complete.		
1524:00 CAM	[sound of several clicks]		
1524:17 HOT-1	your airplane.		
1524:18 HOT-2	I've got the aero machine.		
1524:28 HOT-2	auto throttles.		
1524:30 CAM	[sound similar to that of engines spooling up]		
1524:32 CAM	[sound similar to that of nosewheel on runway]		

INTRA-COCKPIT COMMUNICATION

AIR-GROUND COMMUNICATION

TIME and SOURCE

CONTENT

TIME and SOURCE

CONTENT

1524:33
CAM

[sound of loud bang]

1524:33
CAM

[end of recording]

APPENDIX C—DELTA PROCESS STANDARD 900-1-1

PROCESS STANDARD**PAINT STRIPPING, DRY FILM LUBRICANT AND CARBON REMOVAL - TANK METHOD****1. SCOPE AND USE:**

This Process Standard covers the approved materials and procedures for cleaning, dry film lubricant and carbon removal and paint stripping of various aircraft and engine parts including, primarily, aircraft wheels, landing gear parts, seat parts, and miscellaneous engine parts. These materials and procedures should be used only when and as specified in other approved documents such as Q/H, Mtc. and Component manuals and in lieu of any other similar procedures.

These materials are safe for use on all metals as indicated in flow charts herein.

2. APPLICABLE PROCESS STANDARDS:

NUMBER	TITLE
900-1-1 No. 06	Cleaner - Alkaline Rust Remover
900-1-1 No. 07	Two Layer Hot-Tank Paint Stripper
900-1-1 No. 08	Grease and Carbon Removal - Hot Tank Method
900-1-1 No. 14	Shell Blasting
900-1-1 No. 21	Plastic Media Blasting

3. MATERIAL AND SPECIAL EQUIPMENT:

STOCK NO.	DESCRIPTION	MANUFACTURER
Nonstock	*Stripper & Decarbonizer - Paint, Hot Tank, Alkaline, Non-chromated, Non-phenolic, Combustible (210°F): Turco 5555-B (OR) Ardrox 2302	Turco Products / Ardrox
0312 02076	Stripper - Paint, Hot Tank, Alkaline, Ethanolamine Type, Non-chromated, Non-phenolic (210°F) Combustible F.O. 823	Fine Organics
Nonstock	Stripper - Paint, Hot Tank, Alkaline, Ethanolamine Type, Non-chromated, Non-phenolic (210°F) Combustible F.O. 606	Fine Organics



PROCESS STANDARD

0312 01395	* Additive - Solvent, Stripper Solution, T-5769	Turco Products
Nonstock	* Additive - Inhibitor, Stripper Solution, T-5936	Turco Products
Nonstock	* Additive - Solvent, Stripper Solution, T-6252	Turco Products
0312 01942	Stripper - Paint/Carbon/Dry Film Lubricant, Solvent Amine alkaline Type, Hot Tank, Non-chromated, Non-phenolic, (Non-flammable) Turco 6453	Turco Products
0322 01506	Cleaner, Alkaline, Amine Type, Non- chromated, Non-phenolic; (Non- flammable), Turco 6948R	Turco Products
0342 01005	Compound - Rust Preventive, Turco 2859, Aqasorb, Non-chromated, Non-phenolic, Combustible (140°F)	Turco Products
In-house Mix Shop	Fluid Film/Varsol Mix per P.S. 900-8 #05 Tank - Mild Steel	DAL Spec. Commercial
0312 02060	Paint Stripper - Polyurethane, Non- Phenolic, Non-Chromated, Non-flam, Turco 5668	Turco Product
0322 01045	Cleaner - Alkaline Rust Remover, Non- chromated, Non-phenolic, Non-flam.. Turco 4181	Turco Prod

*NOTE: Used in Dept. 435-2 Turco 5555-B Tank Solution only.

INSTRUCTIONS:

A. Precautions

- (1) Use these materials in a well ventilated area. Avoid prolonged breathing of vapors and contact with the skin. If splashed into the eyes, flush with water and immediately seek medical attention. Proper protective equipment should be worn when working with the materials.

PROCESS STANDARD



B. General Description

(1) Turco 5948R

Used as a pre-cleaner for engine parts. A non-sudsing, free rinsing, alkaline compound. Safe for use on all metals.

(2) Turco 5555B/Ardrox 2302

Used on aircraft parts, including aircraft wheels. Safe on all metals. Removes heavy deposits of carbon. Recommended for stripping acrylics, nitrocellulose lacquers and other easier to remove finishes.

(3) Turco 4181

Used on ferrous and titanium aircraft and engine parts. Alkaline Rust Remover is highly alkaline and will cause caustic burns. Therefore, use rubber gloves, apron and face shields or goggles when cleaning parts or charging tank. For additional information pertaining to aircraft shop use, see P.S. 900-1-1 No. 06; for engine shop tank solution control procedures, see P.S. 900-1-3-2 No. 03.

(4) Turco 5668

Used to remove difficult to strip epoxy, polyurethane or other similar paint system coatings from aircraft and engine parts. This material is safe on all metals, however, prolonged soaking of parts is not recommended. Additional information for tank solution control and aircraft shop use can be found in P.S. 900-1-1 No. 07. CAUTION: PARTS MUST BE FREE FROM WATER OR MOISTURE BEFORE IMMERSION.

(5) Fine Organics F.O. 623 / 606

Used to remove polyurethane paint from aircraft seat parts and other miscellaneous parts. Safe for use on all metal except titanium. Recommended for stripping more difficult to remove finishes.

(6) Turco 6453

Used to soften dry film lubricants/antigallants, carbon and epoxy/polyurethane paints from engine parts. Safe for use on all metals. Usually followed by shell or plastic media blasting.

C. Tank Solution Control/Mixing Procedures



PROCESS STANDARD

- (1) **Turco 5948R Cleaner**
 - (a) **Complete Charge and Solution Addition**
 - 1) Maintain tank solution at normal operating level with Turco 5948R mixed one (1) part cleaner to 4 parts water at 145°-155°F.
 - 2) No laboratory test procedure is required for this tank solution. Dump and recharge tank whenever cleaning solution effectiveness decrease warrants..
- (2) **Turco 5555B/Ardrox 2302 Carbon Remover/Paint Stripper**
 - (a) **Complete Charge and Solution Addition**
 - 1) Use material as it comes from manufacturer. Be sure to use the entire contents of the container (drum) when adding material to the tank. Maintain tank solution at 150°F + 5°F.
 - (b) **Tank Additives**
 - 1) Check tank solution weekly using Turco 5555B or Ardrox 2302 lab test procedures. Maintenance Sds. Testing Shop will indicate from lab test procedures, amounts of stripper additives to maintain tank solution at required performance level.
 - 2) Add either Turco T-5768/201238, T202338, T5769, T5936 or T6252 or applicable Ardrox tank additives as specified by the Maintenance Standards Testing Shop.
- (3) **Turco 4181 Alkaline Rust Remover Cleaner**
 - (a) Refer to P.S. 900-1-1 No. 06 for aircraft shop and 900-1-3-2 No. 03 for engine shop tank solution control procedures.
- (4) **Turco 5668 Paint Stripper**
 - (a) Refer to P.S. 900-1-1 No. 07 for tank solution control procedures.
- (5) **Fine Organics F.O. 623 / 606 Paint Stripper.**
 - (a) **Complete Charge and Solution Addition**

PROCESS STANDARD



- 1) Use material as received from manufacturer. Maintain tank solution at 160°F + 5°F.
- (b) Tank additives
- 1) Check tank solution monthly using Fine Organics lab test procedures.
 - 2) Add F.O. 606 or 623 additive as applicable and as specified by Fine Organics lab test report to maintain tank solution in proper chemical balance.
 - 3) Add mineral oil as required to maintain seal layer at 10-15% of tank solution volume level.
- (6) Turco 6453 Dry Film Lubricant/Carbon/Paint Stripper
- (a) Complete Charge and Solution Addition
- 1) Use material as received from manufacturer. Be sure to use the entire contents of the container (drum) when adding material to the tank. Maintain tank solution at ambient - 150°F.
 - 2) Maintain upper water seal level at 4 inches in depth and 13-15% of total tank solution volume by addition of clean water. Check seal level daily.

D. Pre-Cleaning Parts

- (1) Engine Shop (Dept. 271), Refer to Section L for recommended parts flow.
 - (a) Immerse parts in Turco 6948R Tank for 5-30 minutes.
 - (b) Remove parts from tank and allow excess material to drain back into tank using water spray to remove trapped soap residue.
 - (c) Immerse parts in ambient rinse tank with mild agitation until all soap residue is removed. If necessary, scrub part with soft non-metallic bristle brush and flush part with water. If further wet cleaning is to be accomplished, step (d) & (e) can be omitted.
 - (d) Immerse in a hot water (150-200°F) rinse tank until part equals the temperature of the tank. This will allow for flash drying of most parts upon removal.



PROCESS STANDARD

- (e) Remove parts and allow excess water to drain back into tank. Clean, dry compressed air or vacuum can be used to remove trapped water if necessary.

(2) Aircraft Shop (Dept. 435), Refer to Section L for recommended parts flow.

- (a) Clean parts per P.S. 900-1-1 No. 08 or P.S. 900-1 No. 02 prior to placing in Turco 5555-B/Ardrox 2302 or Fine Organics F.O. 606/623 Stripper Tank, to remove oils and grease and prevent contamination of stripper materials.

E. Paint Stripping/Carbon Removal Procedures - Turco 5555B/Ardrox 2302 - (Aircraft Shop)

- (1) Immerse parts in Turco 5555-B/Ardrox 2302 Tank for 30 minutes or until all paint or carbon is removed.
- (2) Remove parts from tank and allow excess material to drain back into tank.
- (3) Thoroughly rinse parts with high pressure water.

NOTE: Wheels can be shell blasted, as required, to facilitate removal of paint and rubber residue.

- (4) Apply rust preventive compound as required (steel and magnesium).

F. Cleaning/Stripping Procedures - Turco 4181L Alkaline Rust Remover - Engine Shop

CAUTION: DO NOT PROCESS ALUMINUM PARTS PER THIS PROCEDURE. WHEN PROCESSING TITANIUM PER THIS PROCEDURE, DO NOT BATCH WITH OTHER BASE METAL PARTS AND STRICKLY MAINTAIN SOLUTION CONCENTRATION AND IMMERSION TIME.

- (1) Solution concentration 7-9 ounces per gallon of water. Temperature 180°-190°F. Immersion time 10-15 minutes maximum.
- (2) Pressure spray or dip rinse in water. Followed by hot water rinse (135°-200°F).
- (3) Apply rust preventive compound, as required (steel and magnesium).

PROCESS STANDARD



G. Cleaning/Stripping Procedures - Turco 4181L Alkaline Rust Remover (Aircraft Shop)

- (1) See "CAUTION", Para. 4.F. above.
- (2) Solution concentration 32-48 ounces per gallon water. Operating temperature 180°-200°F. Immersion time 4 minutes maximum for titanium; other metals, except aluminum, 30 minutes maximum.
- (3) Pressure spray or dip rinse in water, followed by hot water rinse (140°-180°F).
- (4) Apply rust preventive compound, as required (steel and magnesium).

H. Paint Stripper Procedures - Turco 5668 - (Aircraft and Engine Shops)

- (1) Pre-clean parts per P.S. 900-1-1 No. 08 or P.S. 900-1 No. 02 to remove heavy accumulations of grease, oils and soils.

CAUTION: PARTS MUST BE DRY PRIOR TO IMMERSION IN PAINT STRIPPER.

- (2) Immerse dry part in paint stripper solution for 1-5 hours, as required. Be sure parts are totally immersed in lower layer for upper seal layer has no cleaning/stripping ability and may be corrosive.
- (3) Remove parts and spray/immersion hot water rinse. Do not rinse parts over tank charged with Turco 5668.
- (4) Apply rust preventive compound, as required (steel and magnesium).

I. Paint Stripping Procedures - Fine Organics F.O. 623 / 606 - (Aircraft Shop)

- (1) Pre-clean parts per P.S. 900-1-1 No. 08 or P.S. 900-1 No. 02 to remove heavy accumulations of oils, grease and soils.
- (2) Immerse part in paint stripper solution for 1/2 hour, or as required to remove paint. Be sure parts are totally immersed in lower layer since upper seal layer has no stripping ability and may be corrosive.
- (3) Remove parts and spray/immersion hot water rinse.

J. Dry Film Lubricant/Carbon/Paint Removal Procedures - Turco 6453 - (Engine Shop)



PROCESS STANDARD

- (1) Immerse parts in stripper solution for up to 6 hours maximum, as required.
 - (a) Titanium parts must be processed on an individual batch basis separate from other metals.
 - (b) When placing parts in stripper solution, make certain parts are placed at least 2 inches below bottom of seal layer (parts placed in seal layer will corrode).
- (2) Remove parts from tank and allow excess solution to drain back into tank.
- (3) Thoroughly rinse parts using cold water pressure spray rinse.
- (4) Allow parts to dry.
- (5) Dry Film Lubricant coated parts/painted parts: Inspect parts for complete removal of coatings/paint. If any coating or paint is remaining, reprocess through Step 4.J. above, or if Shell or Plastic Media Blasting is specified on JPC/JIC for part being processed, lightly Shell Blast per P.S. 900-1-1 No. 14 or Plastic Media Blast per P.S. 900-1-1 No. 21.
- (6) Apply rust preventive compound, as required (steel and magnesium parts).

K. Storage

- (1) Store Turco 5555B/Ardrox 2302 in a protected area at a temperature of 40°-120°F
- (2) Turco 5948R - Store in a protected area at a temperature of 40°-120°F.
- (3) Turco 4181 - Store in dry area with container tightly closed.
- (4) Turco 5668 - Store in protected area, out of direct sunlight, preferably at temperature not less than 40°, and not to exceed 120°. Avoid freezing and heating of containers.
- (5) Outdoor storage for F.O. 606 is acceptable within 20°-120°F temperature range.
- (6) Turco 6453 - Store in a protected area at a temperature of 40°-120°F.

PROCESS STANDARD



I. Recommended Parts Flow Chart (Engine Shop)

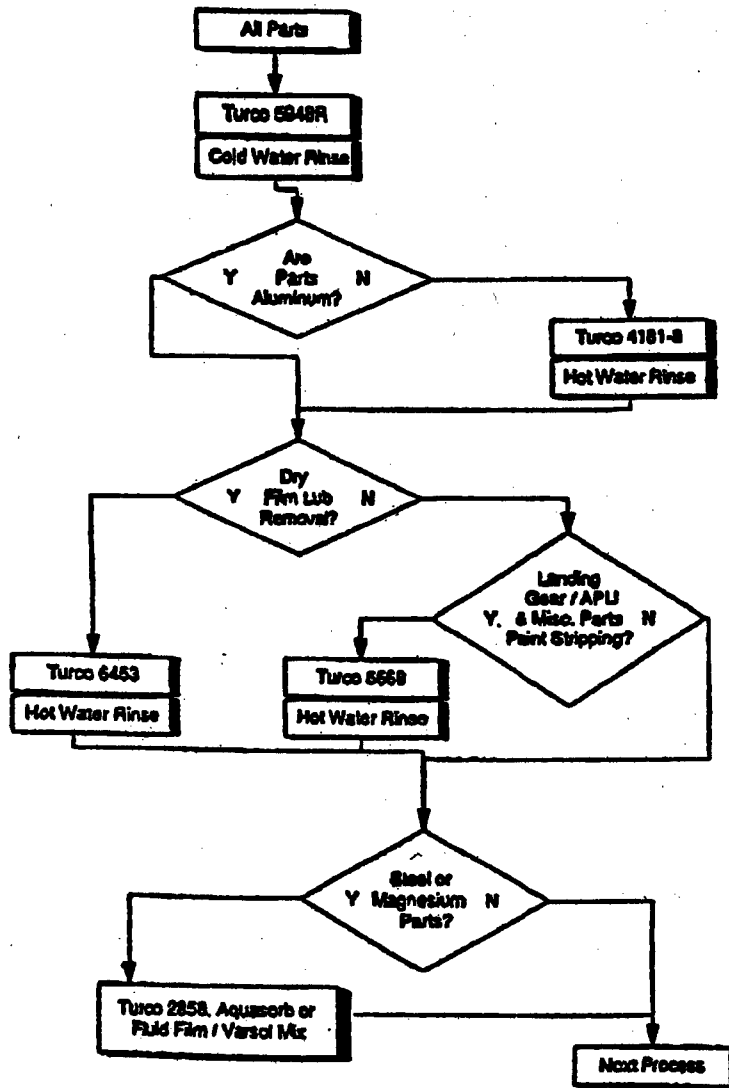

PROCESS STANDARD

L. Recommended Parts Flow Chart (Aircraft Shops)

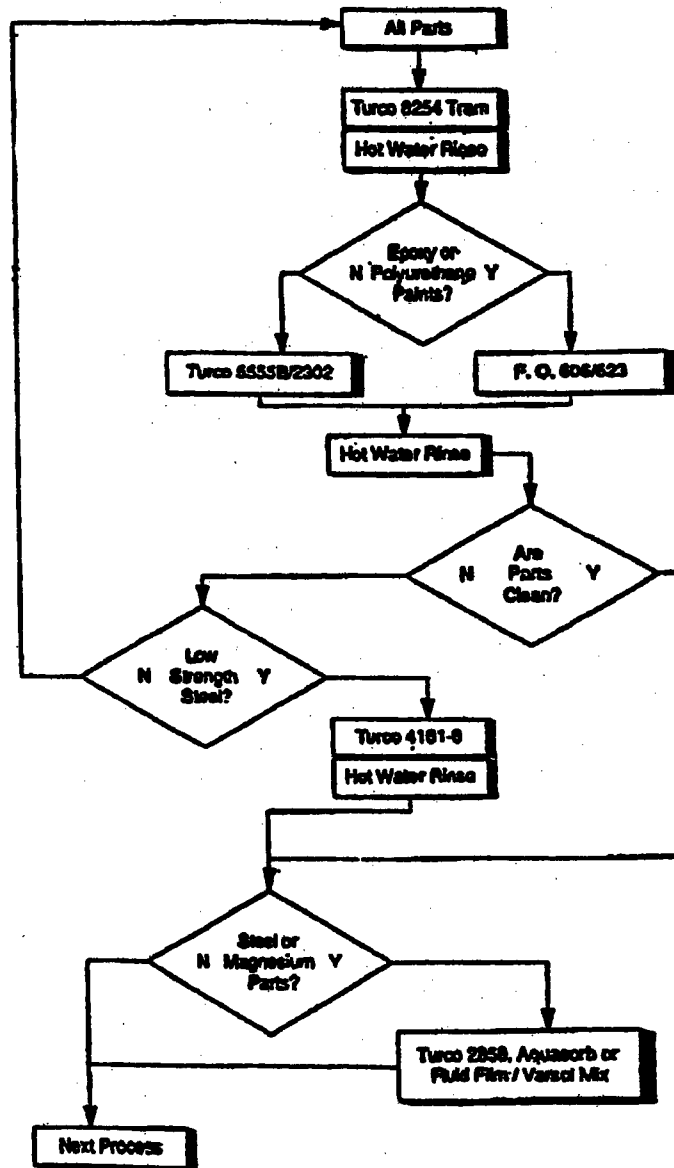

PROCESS STANDARD



PLASTIC MEDIA BLASTING

1. SCOPE AND USE:

This Process Standard covers the materials and procedures for cleaning aircraft and engine parts using dry plastic abrasive blasting media, and shall be used as specified in approved documents and in lieu of any other similar procedures.

Plastic Media Blasting per this Process Standard is safe for use on aircraft and engine ferrous and titanium parts as specified by applicable A/C and Engine O/H and Maintenance Manuals.

2. APPLICABLE PROCESS STANDARDS:

NUMBER	TITLE
900-1-1 No. 09	Cleaning - Aircraft and Engine Parts in the Vapor Degreaser
900-1-1 No. 11	Mineral Spirits - Cleaning

3. MATERIALS AND SPECIAL EQUIPMENT:

STOCK NO.	DESCRIPTION	MANUFACTURER
Shop	Blasting Machine	Commercial
0342 01075	Compound - Rust Preventive, Turco 2858 Aguasorb, Combustible (140°F)	Turco Products
In-house Mix	Fluid Film/Varsol per P.S. 900-8 No. 05	DAL Spec.
0272 01493	*Media, Blasting, Plastic (Poly Urea Formaldehyde), Polyplus 16-20	U.S. Plastic & Chemical
0272 01494	*Media, Blasting, Plastic (Poly Urea Formaldehyde), Polyplus 30-40	U.S. Plastic & Chemical

PROCESS STANDARD

INSTRUCTIONS:

General

- (1) Dry plastic media abrasive can be used for removal of heat scale, carbon deposits, corrosion and rust and for stripping paint in preparation for repainting on steel and titanium parts.
- (2) Do not use this plastic media on aluminum parts except as specified by applicable A/C and Engine O/H and Maintenance Manuals.
- (3) The plastic blasting material must meet the manufacturer's own material specification as well as Pratt & Whitney Specifications PMC3300-2 and SPOP 19.

Precautions

- (1) Parts must be masked properly to protect plated, machined and other surfaces which must not be exposed to abrasive blasting and to prevent abrasives from entering part cavities, ports, tube ends and other entrapment areas where abrasive media is difficult to detect.
- (2) Personnel operating blasting equipment should wear proper protective clothing/equipment.

Procedures

- (1) Vapor degrease parts per Process Standard 900-1-1 No. 09 or clean per P.S. 900-1-1 No. 11, as applicable.
- (2) The blasting operation should be performed so that the gun nozzle will not be allowed to dwell in any one particular spot on the part. The best method is to direct the blast stream at such an angle as to sweep across the surface being cleaned. Use nozzle air pressure of 40 PSI for pressure-type machine and 80 PSI for suction-type machine. Nozzle distance from part surface should be 6-8 inches.
- (3) After blasting, blow clean with air.
- (4) Thoroughly inspect all part surfaces and cavities to assure that no blasting media is entrapped or remaining on surfaces.
- (5) Dip part in Rust Preventive Aquasorb, as required.
 - (a) Alternately, parts may be protected by spraying with mixture of 5 parts Fluid Film "A" mixed with 15 parts new Varsol. (Ref. P.S. 900-8 No. 05)