

JPRS-UEQ-89-005  
24 MARCH 1989



**FOREIGN  
BROADCAST  
INFORMATION  
SERVICE**

# ***JPRS Report***

# **Science & Technology**

***USSR: Engineering &  
Equipment***

REPRODUCED BY  
U.S. DEPARTMENT OF COMMERCE  
NATIONAL TECHNICAL INFORMATION SERVICE  
SPRINGFIELD, VA. 22161

**DISTRIBUTION STATEMENT A**  
Approved for public release;  
Distribution Unlimited

**DTIC QUALITY INSPECTED**

**19980511 104**

# Science & Technology

## USSR: Engineering & Equipment

JPRS-UEQ-89-005

CONTENTS

24 March 1989

### Nuclear Energy

BSSR Officials Discuss Chernobyl's Aftermath [SOVETSKAYA BELORUSSIYA, 9 Feb 89] .....	1
Method of Calculating True Steam Content by Volume in Reactor Unit Components During Strong Leakage [N. A. Kevkhushvili, M. Sh. Loladze; SOOBSHCHENIYA AKADEMII NAUK GRUZINSKOY SSR, Vol 131 No 2, Aug 88] .....	10
Calculation-Experimental Determination of Radiation Heating of Elements of Interreactor Monitor of VVER-440 [A.S.Zakharov, S.A. Andrushechko; ELEKTRICHESKIYE STANTSII, No 6, Oct 88] .....	12
Corrosion Protection at Crimean AES [V.G. Shigorin, A.G. Volnistov, et al; ELEKTRICHESKIYE STANTSII, No 6, Oct 88] .....	14
Integrated Startup Tests of 1,000-MW Generator-Transformer Module of AES [V.A. Kolychev, Ye.V. Savchenko, et al; ELEKTRICHESKIYE STANTSII, No 6, Oct 88] .....	17
On Pricing for Electric Power of AES [B.E. Ratnikov, L.D. Gitelman, et al; ELEKTRICHESKIYE STANTSII, No 6, Oct 88] .....	21
Holding and Transfer Pond for Nuclear Fuel [Yu. P. Kaloshin, S. L. Belokhin, et al.; OTKRYTIYA IZOBRETENIYA, No 41, Nov 88] .....	24

### Non-Nuclear Energy

Study of Light Transmission Coefficient of Certain Materials Used in Solar Technology [M. V. Kacharava; SOOBSHCHENIYA AKADEMII NAUK GRUZINSKOY SSR, Vol 131 No 1, Jul 88] .....	25
Use of Reinforced Concrete Supports on 6-10 kV Power Transmission Lines in Western Siberia [Ye. I. Teterev; VESTNIK MASHINOSTROYENIYA No 10, Oct 88] .....	27
Protecting Territories From Flooding During Construction of Reservoirs [E. G. Kotenkova, N. V. Zub; VESTNIK MASHINOSTROYENIYA No 10, Oct 88] .....	27
New Technology for Installation of TGME-206 Boiler Units [V. S. Smirnov, K. V. Kuznetsov; VESTNIK MASHINOSTROYENIYA No 10, Oct 88] .....	27
Means for Improving Combustion of Low-Grade Anthracite Fines at Electric Power Plants [Yu. L. Marshak, Yu. P. Artemev, et al.; TEPLOENERGETIKA No 9, Sep 8] .....	27
New Battery Cyclone to Trap Hard and Brown Coal Dust [V. A. Reznik, P. M. Luzin, et al.; TEPLOENERGETIKA No 9, Sep 88] .....	27
Method of Decreasing Effect of Power Plant Noise on Urban Residential Areas [A. F. Dyakov, N. I. Serebryanikov, et al.; TEPLOENERGETIKA No 9, Sep 88] .....	28

### Industrial Technology, Planning, Productivity

Group Machining Components on Numerical Program Control Machine Tools [G. F. Volodchenko, L. I. Kononenko, et al.; MASHINOSTROITEL, No 10, Oct 88] .....	29
External Gear Train [M. A. Voronchikhin; MASHINOSTROITEL, No 10, Oct 88] .....	29
Machining FMS—Integral Part of Modern Production Plans [V. I. Zagurskiy; MASHINOSTROITEL, No 11, Nov 88] .....	30
Loading Device for Centerless Grinding Machines [N. U. Chernenkiy, M. A. Kaganovskiy; MASHINOSTROITEL, No 11, Nov 88] .....	35
Boring Head [V. V. Belyanin; MASHINOSTROITEL, No 11, Nov 88] .....	36
Increasing Precision of Milling Cylindrical Surfaces [M. D. Medvedev, L. M. Natapov; MASHINOSTROITEL, No 11, Nov 88] .....	36
Rolling-Contact Bearing With Enhanced Damping [A. N. Teuges, A. G. Pavlov; MASHINOSTROITEL, No 11, Nov 88] .....	37
Split Ball Nut [V. F. Salomatov; MASHINOSTROITEL, No 11, Nov 88] .....	38
Hydraulic Elastic Expanding Clutch [B. P. Spruogis, L. A. Zubavichyus; MASHINOSTROITEL, No 11, Nov 88] .....	39
Spot Welding Unit [A. N. Ganzha; MASHINOSTROITEL, No 11, Nov 88] .....	40
Elastic Tooth-type Coupling [Yu. M. Guzenko, M. S. Kovalev, et al.; MASHINOSTROITEL, No 11, Nov 88] .....	41

Vibratory Mills [B. Ya. Opirskiy, P. D. Denisov; MASHINOSTROITEL, No 11, Nov 88] .....	41
Break Testing Diaphragm Specimens [L. F. Semenychev; MASHINOSTROITEL, No 11, Nov 88] .....	43
New Electrospark Production Equipment [MASHINOSTROITEL; No 11, Nov 88] .....	43
Planning of Electromechanical Industrial Robot Drives [Ye. P. Soldatkin; STANKI I INSTRUMENT No 9, Sep 88] .....	44
System for Automated Planning of Electromagnetic Industrial Robot Clamping Devices [Yu. D. Zhabotinskiy; STANKI I INSTRUMENT No 9, Sep 88] .....	44
Dynamic Analysis of Robot Assembly of Cylindrical Joints [M. N. Polishchuk, L. S. Yampolskiy, et al.; VESTNIK MASHINOSTROYENIYA No 6, Jun 88] .....	44
Replacement of Nonferrous Metals With High-Strength Cast Iron [L. A. Solntsev, V. D. Shifrin, et al.; VESTNIK MASHINOSTROYENIYA No 6, Jun 88] .....	44
Increasing Accuracy of Grinding Interior and Exterior Surfaces of Shaped Joints [A. I. Timchenko, A. V. Bogolyubov; VESTNIK MASHINOSTROYENIYA No 6, Jun 88] .....	45
Influence of Epilam on Antiskip Properties of Guides [A. S. Lapidus, N. V. Gitis; STANKI I INSTRUMENT No 9, Sep 88] .....	45
Reverse Expansion in Rotary Compressor With Rolling Rotor [V. Ye. Shcherba, I. S. Berezin, et al.; KHIMICHESKOYE I NEFTYANOYE MASHINOSTROYENIYE No 7, Jul 88] .....	45
Use and Sharpening of Complex Multiple-Edge Tools [S. V. Bulgakov, O. L. Paramey; KHIMICHESKOYE I NEFTYANOYE MASHINOSTROYENIYE, No 7, Jul 88] .....	45
Creation of Rotary Lines to Form Rubber Products [A. S. Nefedov; KHIMICHESKOYE I NEFTYANOYE MASHINOSTROYENIYE, No 7, Jul 88] .....	45

**Miscellaneous**

Small Amphibious Air Cushion Vessels for National Economy [V. A. Vavilin, V. V. Protsenko, et al.; SUDOSTROYENIYE, No 11, Nov 88] .....	47
--	----

**BSSR Officials Discuss Chernobyl's Aftermath**  
*18000550 Minsk SOVETSKAYA BELORUSSIYA*  
*in Russian 9 Feb 89 p 2*

[Report on public meeting on 2 February with BSSR officials, reported by Yu. Bekhterev and Ye. Gorelik, BELTA correspondents, and M. Kuchko and N. Mikhailchik, ZVEZDA correspondents: "One Thousand Days After Chernobyl"]

[Text] Almost three years have passed since that April day when we became firmly aware of the bitter word, "Chernobyl". The explosion at the AES, like an x-ray, lighted up both some criminal negligence and our general lack of readiness for defense against the "peaceful atom" which had become disobedient, and revealed the unparalleled courage and staunchness of some, and the indifference and cowardice of others.... Need we repeat how greedily we kept trying, all this time, to grasp the meaning of the newspaper lines, how anxiously we scrutinized the close-ups of a newsreel, hoping to obtain answers to the questions that multiplied and grew like snowballs after the accident. The information, we will say honestly, was filled in. As happens in such cases, rumors and conjectures began to take over. They excited minds and hearts, and accumulated in the already heated atmosphere around Chernobyl.

To remove it and clarify the situation, on 2 February a public meeting was organized with the community, made up of a commission of the Bureau of the Central Committee of the Communist Party of Belorussia and the BSSR Council of Ministers on eliminating the consequences of the accident at the Chernobyl AES. The interest which it aroused can be judged by this: long before it started, people began to gather at the entrance to the Palace of Culture of the Belorussian Council of Trade Unions.

The accustomed presidium was not on the stage, but for the first time there were published maps of the radiation contamination for the rayons of the republic. There were microphones installed not only on the stage, but also on the mezzanine and in the balconies: you could go up to them, ask questions and object.

In opening the meeting, V.G. Yevtukh, chairman of the commission, first deputy chairman of the BSSR Council of Ministers, emphasized the fact that the Central Committee of the Communist Party of Belorussia and the republic's council of ministers felt it necessary to inform the public about the work of the commission, and on what measures were being taken to protect the health of the people and safe residence in the rayons that had suffered.

"I should like to note," he said further, "that from the moment of the accident the problems of eliminating its consequences and ensuring the safety of the population have been the constant focus of attention of the Central Committee of the Communist Party of Belorussia and

the government of the republic. N.N. Slyunkov, former first secretary of the Central Committee of the Communist Party of Belorussia, is actively concerned with them. From the first days after the accident, he went out to the rayons that had suffered and took efficient measures on the spot to give party assistance to the local party and Soviet organs in normalizing the situation. He directly guided the strategy for combating the calamity that our people had suffered."

Ye.Ye. Sokolov, first secretary of the Communist Party of the Belorussian Party Committee, G.S. Tarazezich, chairman of the Presidium of the Supreme Soviet of the republic, and M.V. Kovalev, chairman of the BSSR Council of Ministers, the directors of the republic, are paying fixed attention to this problem today.

To coordinate the activity of the republic ministries, departments and organizations, a commission of the Bureau of the Central Committee of the Communist Party of Belorussia and the BSSR Council of Ministers was created, including the secretary of the Central Committee of the Belorussian Communist Party, three deputy chairmen of the BSSR Council of Ministers, and directors of the interested ministries, departments and oblispolkoms.

In the first few days after the accident, extreme measures were taken, and evacuation of the 11,400 inhabitants from the 50 population centers of the 30-kilometer zone of the AES was completed as early as 5 May 1986. Then, as the radiation situation changed, the need arose for evacuation of an additional 6000 inhabitants from 28 villages (in June 1986) and another 7300 persons from 29 population points (in August-September 1986).

All the evacuees were immediately given temporary housing, and the able-bodied, in addition, work.

Some 170 new, well-appointed rural settlements were created in the territory of Gomel Oblast, outside the limits of the radioactive contamination zone, where 9770 apartments were constructed in country-type houses with outbuildings.

In the middle of May 1986, on the territory of 11 rayons in Gomel Oblast and 6 rayons in Mogilev Oblast, a zone of radioactive contamination with cesium-137, with a contamination density of 15 Curie units and more per square kilometer, was discovered, in which 415 population centers with over 100,000 inhabitants were located.

In these population centers a great deal of work will be done to decontaminate all the housing, public, administrative and farm buildings. A great amount of work is being done for public service and amenities, in order to create normal living conditions and carry out a set of land improvement and agrochemical measures.

Over 140,000 children, students and pregnant women yearly undergo health treatment in sanatoriums, rest homes and pioneer camps, for which 30 million rubles a year is spent.

Delivery of clean food products was organized for the people in rayons that proved to be in the zone of radioactive contamination.

A scientific software system was set up for problems related to eliminating the consequences of the accident on the territory of the republic. General direction was entrusted to the BSSR Academy of Sciences, within which a special Institute of Radiobiology was formed. In addition to this institute on radiation subjects, 19 other academic institutes are in operation. An Institute of Medical Radiology with a polyclinic was created within the system of the BSSR Ministry of Health. The Sanatorium of Main Administration No 4 of the BSSR Ministry of Health at Aksakovshchina was turned over to house it. A Belorussian branch of the All-Union Scientific Research Institute of Agricultural Radiology was opened in Gomel. Divisions of radiation monitoring were organized at all 10 scientific research institutes of the BSSR Gosagroprom [State Agro-Industrial Committee].

Because of all the work done to eliminate the consequences of the calamity, not a single case of a health violation for people, caused by radiation factors, was permitted. The total dose of irradiation for people in the years that have passed does not exceed the established norms.

At the same time, the situation in the zones contaminated by radionuclides, as before, requires steady attention, both along the line of republic and local organs and on the part of union ministries and departments. Not long ago the directors of the republic made an appeal with a letter addressed to M.S. Gorbachev, General Secretary of the CPSU Central Committee and N.I. Ryzhkov, chairman of the USSR Council of Ministers. We are sincerely grateful to the CPSU Central Committee for their constant attention to our problem, and for the positive evaluation given by the Politburo of the CPSU Central Committee of the work done in the republic and the concern shown for the Belorussian people, which was reflected in the resolution adopted.

This year already, 243 million rubles of state centralized capital investments and the necessary material-technical resources have been allotted for the express intention of eliminating the consequences of the accident. The total amount of these resources for the four years since the accident is about 1.15 billion rubles. The problem of additional supply this year has been solved for Mogilev and Gomel oblasts with 110,000 square meters of factory manufactured homes, a large quantity of pipes, petroleum bitumen, cable products, equipment and other material resources sent from other regions of the country.

We have not yet fully succeeded in solving problems along the line of the USSR Gosagroprom and particularly, those connected with allotting the necessary capital investments to construct livestock breeding and other production facilities to replace those left in the confiscated and depopulated zones. We should intensify work in this direction.

A great deal of work must be done for additional resettling of people living in those population centers which cannot ensure staying within the maximum permissible irradiation dose, recently established in our country, of the 35 roentgen equivalents which a person can receive in his lifetime. Incidentally, this dose meets international norms.

In connection with this, I should like to emphasize the fact that this by no means indicates that we permitted any errors or omissions earlier. I wish to repeat: in the last three years, no exceeding of the maximum irradiation doses established through the years has been permitted. It is now a question of not permitting the lifetime human doses that we first established to be exceeded. Here the situation must also be borne in mind: people from some small population centers with decrepit houses will resettle into new, well-appointed houses, built on clean territory, for the reason that the expenditures for this are considerably less than the resources that would be required to put the old ones in order.

#### Are We Safeguarding the Health of the People?

##### The Opinion of a Specialist

V.N. Buryak, BSSR deputy minister of Health, chief State Sanitation Physician of the BSSR:

Let us begin with the figures. Over 520,000 persons living in the republic were exposed to radionuclides with a varying level of contamination. You will agree that the situation that has formed is not a simple one, and required from doctors a concentration of efforts, coordinating the action of all the services and determination of the priority directions in safeguarding the health of the people. Today, three stages can be singled out, according to the time of their implementation.

The first is the stage of extreme measures, determined by the limits of the predicted doses through external radiation and irradiation of the thyroid gland in children. It is precisely on the basis of the possible exceeding of the safe limits of irradiation that, soon after the accident, the decision was made to evacuate the people and give a preventive dose of iodine preparations.

The second is the stage of restrictions and monitoring of living conditions. It is urgent even today for a large number of population centers where, as has already been mentioned, over 100,000 people are living. The criteria on which we judge living to be hazardous consist of two indicators: the density of the soil contaminated with

radionuclides and the yearly maximum dose of irradiation. We will recall that for cesium-137, the most widespread in the republic, they are 15 Curie units per square kilometer and 10 roentgen equivalents for the first year after the accident, 3 for the second and 2.5 roentgen units each for the third and fourth year.

The general efforts of all those participating in eliminating the consequences of the accident at the first stages proved to be quite efficient: none of the inhabitants evacuated received the maximum dose of 75 roentgen units. The irradiation doses of the thyroid gland also proved to be lower by a factor of 5-20 than those anticipated. The total irradiation dose for the inhabitants of the zone being monitored in 1986-1988 was 9 roentgen units, and on the other territories, 3.3 roentgen units, with a permissible limit of 15.5 roentgen units.

Several persons, true, exceeded this limit: 38 in Mogilev Oblast and 10 in Gomel. I will note that all of them were pensioners and elderly people, who openly ignored the recommendations not to use their own products and did not maintain the prescribed sanitary conditions.

On the whole we can safely state that we succeeded in safeguarding radiation safety for the people. This, incidentally, was also confirmed at the all-union conference in Kiev, in which many scientists from foreign countries participated. Last fall, the concept of safe living for the people on the territories contaminated with radionuclides was worked out, substantiated and confirmed. It is based on one criterion—the maximum dose for a lifetime—and consists, as has already been mentioned here, of 35 roentgen units for approximately 70 years. This value also includes the emergency dose. The concept stipulated returning to the accustomed life style and removing all restrictions on living conditions and use of local products.

Within the framework of this concept, a prediction was made of the doses for 70 years for each population center where a stable change in the radiation situation had been noted. For places where this level might exceed the maximum, a list of measurers for engineering and agrotechnical decontamination was prepared. If these measures do not yield the necessary effect, the inhabitants will have to be evacuated to safe places. That is precisely the reason that in the next two years it is planned to move away the inhabitants of approximately 20 population centers. About 3000 persons are presently living in them.

In a few dozen more villages, additional inspections are to be made this year, and a specific decision will be made according to their results. As for the rest of the villages in the stricken rayons, all the restrictions there can be removed, since the predicted lifetime dose here is less than 35 roentgen units.

I shall speak now in more detail on the greatest worry of the republic's population today: the state of health of the people and the possible increase in the number of

illnesses. On the basis of recommendations and documents of the International Committee on Radiation Protection, we predicted the morbidity in consideration of the late somatic, genetic effects or oncological risk. Calculations show that, for example, the additional number of cases of oncological sickness will not exceed 0.5 percent of today's level. It should be noted that with the present growth rate of spontaneous cancer disease in the republic, which is 3-5 percent a year, even statistically it will not be possible to establish this addition. The evaluation of the genetic risk is analogous: it exists of course, but its value too can hardly be detected.

A few words on the state of health of the population of Gomel and Mogilev oblasts. The structure of general morbidity in them last year did not change. The level of infant mortality in the last three years has a stable trend toward reduction, including that in the stricken areas. The increase in those suffering from malignant tumors here is also no different from the level formed.

Today it is possible to speak of certain progress in providing the stricken areas with a sufficient quantity of medical workers. Over 600 physicians and 1687 intermediate medical workers were sent here in 1987. This year, in the distribution of graduates from medical teaching institutions, over 2000 additional medical workers with higher and secondary qualifications were sent. The purposeful acceptance of entrants from Gomel and Mogilev oblasts to medical VUZ's and schools has been expanded, training of paramedics and laboratory assistants, dental technicians and physicians has been organized at schools in Gomel and Mogilev oblasts.

Still, it must be said, that these regions are not fully provided with medical personnel. We cannot, unfortunately, satisfy their demands for medications, medical materials and equipment. The funds allotted to the republic for them is still clearly insufficient.

[Question] Many medical workers have left the radiation zone. Does this not indicate that specialists who really know the situation well, do not want to risk their health and stick their head in a noose

[V. Buryak] Physicians really know the situation well enough, and therefore many of them have gone to work in the zone without any hesitation. At the beginning of this year, in all the rayons except for Krasnopolskiy and Vetkovskiy, the number of personnel has been re-established. In addition, some medical personnel who went away "from the radiation" in 1986, have now returned to their hospitals.

[Question] The number of sick people in Khoynikskiy Rayon has risen sharply. The otolaryngological division of the local hospital has had to expand five-fold, and still does not have enough beds. What can you say about this?

[V. Buryak] The number of acute respiratory ailments has increased, not only in Khoynikskiy Rayon. Remember, though: last year an influenza epidemic rolled through the republic. Up until then, we had somehow been spared from this disease for about four years. The increase in the sickness rate, paradoxical as it may be, also called for the best work of the medical personnel. The first stage of the dispensary system always leads to a rise in these indicators. This is a general conformity to principle, in no way related to the radiation situation. The point here lies in something different. Many chronically ill people, who had not once turned to a physician (some of them even boast: "I went through the flu on my feet"), have now been put under supervision. Here you have an improvement in medical service and deterioration in statistics. There were cases of acute respiratory illnesses even among children who were taken away to pioneer camps in other oblasts. I would not take the liberty of blaming radiation for this, however. Parents whose children go to kindergarten well know that the little ones always become sick first. Some sort of period of adaptation must be undergone, until the organism adjusts to the new conditions.

I do not want to deceive anyone and state that in general we have no basis for worry. Recent studies of students have revealed preclinical health disturbances in some groups of the population. Fortunately, they are not so great that they fail to be compensated for and thus cause diseases. The most serious studies in this field are continuing, and these directions in medicine, just as child hematology and endocrinology, are being developed very actively in the republic.

At the same time, and I emphasize this once again, there were and are no outbreaks of sickness. Here are the official data: the level of temporary inability to work in 1988 increased by approximately 8 percent: the influenza epidemic had its effect, as well as the increase in leaves of absence to care for sick children.

[Question] At children's preschool institutions in the stricken rayons, they are still making soups using marrow broth. Is this not dangerous?

[V. Buryak] We have made special studies. It turned out that in boiling, only hundredths of the percent of strontium contained in bones pass into the broth. There is no health hazard in this.

[Question] To what was the recent ban against giving children vegetables related?

[V. Buryak] Not to radiation. It has already been precisely established that even on the most contaminated lands, the vegetables are growing clean. The autumn ban against giving vegetables to small children in kindergarten was connected to the threat of infectious disease which arose during that period.

[Question] Why do you name only Union norms for the permissible radiation contamination of food products and not mention analogous norms in other countries?

[V. Buryak] I can inform you that the absolute majority of our norms do not exceed the existing parameters adopted in other countries of the world, and by MAGATE [IAEA] and the Scientific Committee on the Effect of Nuclear Radiation for the UN.

[Question] When can the inhabitants of the republic obtain individual dosimeters to use at their own discretion?

[V. Buryak] We need individual dosimeters today not so much from the medical, as from the psychological standpoint, as one more measure capable of dispelling people's doubts and keeping them calm. Where there is a real risk of the population's receiving increased doses of irradiation, the medical institutions carry out tests constantly. Many lumbermen, machine operators and livestock breeders have individual dosimeters, in addition to which they are regularly checked at radiological laboratories equipped with the most precise instruments.

If someone wishes to check his health, I can give an address where he can undergo a full course of testing: Minsk, Institute of Radiation Medicine, Krasnoarmeyskaya Street, 15.

[Question] What is the total amount of money allotted by the BSSR Council of Ministers directly for health needs connected with Chernobyl?

[V. Buryak] The Ministry of Health has received approximately five million additional rubles to increase health payments to medical workers. I will add, that we are not at this time involved in any restrictions in wages. If a specialist comes to the stricken areas, we are always ready to assign him a wage rate. About five million rubles have been used to purchase equipment. In addition, industrial enterprises transferred about seven million rubles in five categories of currency to us for equipment. About 152 million rubles were allotted for construction and development of the material-technical base. Unfortunately, the construction workers did not succeed in utilizing all the funds.

[Question] Why was the May Day demonstration not forbidden in Minsk in 1986?

[V. Buryak] Although the radiation situation in Minsk actually changed somewhat after the Chernobyl accident, the levels of the gamma background presented no danger. Therefore, there was no need to postpone the demonstration. In a word, rumors concerning the fact that on 1 May 1986 the demonstrators were under a radioactive rainfall are simply absurd. We checked with meteorologists, and there was no rain in Minsk on that day. The radioactivity of the precipitation, even in the first few days after the accident, were negligibly higher, and represented no danger to the people's health.

## Is Radiation Yielding Its Position?

### The Opinion of a Specialist

Yu. M. Pokumeyko, chief of Belgidromet

Before the accident, inspections of the radiation levels were made once a week at all the meteorological stations of the republic at the same time. Early in May, a center for radiation-ecological control was organized—laboratories which regularly took samples of the air, soil, water and bottom deposits—and gamma-photographs were made of the locality by airplanes and helicopters. An automated telemetering system was installed in a 30-kilometer zone, which made it possible to obtain information on the levels of gamma-radiation, air temperature, amount of liquid precipitation and wind parameters.

The main zones of contamination had been intensively studied by September 1986. It was possible to determine their boundaries and to draw them on a map. The picture proved to be very spotty. Two main "patches" were clearly established: the southern—the south of Gomel Oblast—, and the northern—the north of Gomel and south of Mogilev oblasts. The first patch was characterized by high levels of gamma-radiation in the first few days after the accident, through fallout of the short-lived iodine-131 radionuclides. In addition, isotopes of Cesium-137 were detected here, and on the boundaries of the 30-kilometer zone—strontium-90 and plutonium-239-240. Inhabitants of the population centers that had been subjected to strong contamination were resettled, and others went to a constant-monitoring zone.

The northern patch was formed through fallout, mainly of cesium-137 radionuclides, with the rains. The level of gamma-radiation here did not rise to dangerous limits, and therefore there was no need for immediate resettling of the people. Many population centers, however, are in a constant-monitoring zone.

Precise determination of the situation continued. Over 2000 population centers were thoroughly examined, and as a result, a map of the radioactive contamination of the entire territory of the republic was compiled. Incidentally, it was impossible to publish these maps until all the data was in. Thus, about 18 percent of the republic territory was subjected to contamination. There are 415 population centers in the constant-monitoring zone.

Today, as the result of the decay of the short-lived radionuclides and decontamination, the dose rates of gamma-irradiation have been greatly reduced. At the same time, the natural burying of radionuclides is taking place very slowly: in the first years, 80-90 percent of them were held in the upper five-centimeter layer of soil. In ten years, according to our calculations, the radionuclides could lower to a depth of 10-20 centimeters. We are transmitting data on the radionuclide situation to interested organizations.

A.L. Grishagin, chief of staff of BSSR Civil Defense:

[A.L. Grishagin] Before the accident we had largely instructed the people on how to organize evacuation to cities in the rural area. In practice, we had to carry out the removal from the rural areas. In addition, the administrative organs and civil defense subdivisions proved to be poorly trained. All the same, the confusion of the first few days quickly passed, and the actual attack on the radiation had already begun in May. In 1986, some 246 population centers in Gomel and 20 in Mogilev oblasts had been decontaminated. In the next two years, 432 population centers were decontaminated. In addition to the civil defense subdivisions, representatives of over ten ministries and departments worked on decontamination and public services and amenities for the villages. It is simply impossible to enumerate everything that they did. One thing I can say for certain: after all the work was completed, the gamma-background was reduced by a factor of 2-3 and the density of contamination with cesium-137 was lowered several-fold.

[Question] How is the level of radioactivity now being monitored?

[Yu. Pokumeyko] The quick-analysis system, in effect throughout the territory of the republic, sets the daily level of radiation. In addition, twice a year we make a comprehensive examination and determine the density of radionuclide contamination of the soil. While the first time we experienced many difficulties, cause of the shortage of and imperfections in the diagnostic apparatus, today all the laboratories, both in the center and in the outlying regions, are equipped with modern instruments, reacting to the slightest change in the radiation background.

[Question] Why has construction not been completed on centers for special processing of motor transport and equipment at Bragin and Narovl?

[A. Grishagin] The decision on constructing these centers was made in the initial period, when a great deal of equipment and transport was drawn from other rayons and oblasts to eliminate the consequences of the accident. This zone now contains mainly equipment from the local kolkhozes, sovkhozes and organizations. Because of this, it was decided to create internal decontamination centers at all the machine yards in the constant monitoring zone. The uncompleted facilities should be equipped as technical service stations for motor vehicles.

[Question] Many civil defense subdivisions have been equipped with dosimeters, but immediately after the accident they were removed for some reason.

[A. Grishagin] This was not done in order to conceal the irradiation doses obtained. The dosimeters removed were for military purposes, calculated for work under



radiation conditions with an intensity of over 2 roentgens an hour. For us, however, the count was made for tenths and hundredths of a roentgen. This required completely different, much more "precise" instruments. All interested organizations now have these, by the way, and no secret is made of their readings.

[Comment] I am deeply convinced: it is civil defense that is to blame for the fact that our people proved to be unprepared for an encounter with radiation. Apparently, it is time for us to restructure the methodology and practical work of instruction and to put it on a practical course. Only in this event will there be any benefit from the knowledge.

[Question] Do you know how many people are today living "beyond the pale"—in the 30-kilometer zone?

[A. Grishagin] Some 104 people are living in Braginskiy Rayon in the village of Sobol, 78 in Savichi, and 18 in Krasnaya Gora. All of these people settled in voluntarily. Only, these villages are not "beyond the pale," but "in front of the pale," and moreover, several tens of kilometers away. No one is living in the actual zone of "alienation."

[Question] How will civil defense be occupied this year?

[A. Grishagin] Additional decontamination work is to be done at 415 population centers in the zone of constant monitoring.

[Question] Is there any danger of the radiation zones expanding?

[V. Yevtukh] Essentially, no, but all the same, a unique redistribution (by the wind, let us say) of radionuclides cannot be ruled out. Therefore we have also created an expensive, multi-stage monitoring system, in order to have constant exhaustive information on the radiation situation on the entire territory of the republic and, if necessary, to take efficient measures.

#### Is There "Clean" Grain in the "Contaminated" Zone?

##### In the Opinion of a Specialist

Yu. M. Khusainov, first deputy chairman of the BSSR Council of Ministers, chairman of the BSSR Gosagroprom:

To live or not to live on the wounded land? Does the answer to this question depend not only on whether we are protected from radiation, and "wash" the dangerous dust from houses and roads? Who needs these houses, if a person cannot lay his hands on anything? Therefore, a few days after the accident, the republic Gosagroprom began to work out a concept of conduct for agricultural production in a contaminated locality. Today its basic premises have been quite clearly outlined. In conjunction with the BSSR Ministry of Health and an interdepartmental committee of scientific radiology experts, we

have sent appropriate recommendations to the farmers three times. By following them, feed and grain can be grown on practically the entire territory of the republic, and livestock breeding products can be obtained with a radionuclide contamination level not exceeding the norms. What sort of recommendations are these?

On the basis of over 40,000 analyses of the soil from 5 million measurements of the radiation product, detailed maps were compiled of the contamination of the soil surface at each farm and rayon. It became clear where, and which crops could be raised. For example, on the basis of a three-year observation we were convinced that grain crops need not fear fields with a contamination density of up to 40 Curie units per square kilometer, potatoes—50, rape seed—up to 20, clover and vetch—up to 10 curies on water-logged and up to 20-30 curies on hay from natural feed harvests, particularly on water-logged soils, can be procured, if there are not over 2 curies. It turns out that it is only necessary to select correctly the fields for each crop, and the product will be clean. Where it is impossible to grow such a product—in the zone with a contamination density of over 80 curies per square kilometer—all production is in general curtailed, and these sections will be planted with forest.

Can a clean product in practice be obtained from a "contaminated" field? Here are the figures. In 1986 over 5.3 percent of the feed procured failed the examination for radioactivity, in 1987, 2.8 percent of it, and last year 1.6 percent. The dynamics for grain are analogous. As you can see, the people have learned to work under the most complex conditions.

Now about meat. We obtain clean pork practically everywhere. Unfortunately, beef and milk "absorb" radiation more actively. Many people know about this and are afraid in advance. I wish to read from a letter which came to Gosagroprom. The comrade writes that they sent a consignment of beef from their farm to a meat combine. At first it was not accepted, and was returned. A month later they sent these animals off and they were turned over without any complications. What is this, the authors ask indignantly. Meanwhile, it is all very simple—cesium 134 and cesium 137 are biologically very mobile radionuclides. By replacing rations that include contaminated fodder, the nuclides are carried off from the body of the beef cattle in two or three months. The government of the republic allotted, especially for 1989, 274 thousand tons of concentrated fodders to kolkhozes and sovkhozes in Gomel and Mogilev oblasts, in order to organize final fattening there and obtain a "clean" product.

This means that the "contaminated" land is not infertile. It can feed people if, of course, the farmers use it competently.

A few words on the product quality control. Today, in each rayon in Gomel and Mogilev oblasts, as well as in individual rayons of Brest, Minsk and Vitebsk oblasts,

393 radiological laboratories have been set up, including 124 veterinarian, 60 agrochemical, 24 at meat combines, 93 at processing enterprises, 58 at food enterprises and 34 at fruit and vegetable enterprises. Every farm located in a zone of contamination of over 15 curies per square kilometer has its own dosimetric posts. A total of 356 such posts is in operation at kolkhozes and sovkhozes.

Depending on the extent of radiation contamination, each republic is divided into three zones: "clean," "monitored periodically," and a "restricted" zone, or, as it is called, of "constant monitoring." There is occasional radiation monitoring in the "clean" zone. In the second zone, selective monitoring. In the third zone all the products are monitored. This is carried out both at the kolkhozes and sovkhozes and at individual subsidiary farms. All the laboratories are well equipped. Today we have over 16,000 different instruments, amounting to a total sum of over 9 million rubles. The system created ensures reliable monitoring of the product quality.

[Question] You said that a small percentage of the products is contaminated. Where, in this case, are the radioactive meat and milk used?

[Yu. Khusainov] Most of the contaminated products were obtained in 1986. Of 28,000 tons of this meat, which passed through the meat combines, 3900 tons were buried, 5000 tons were used to prepare dry feed, and 15,000 tons were exported for this purpose to other regions of the country. Some 400 tons were sent to fatten up fur bearing animals. The rest is so far in storage. When construction of a grave in the Chernobyl area is completed, all of this meat will be buried there. The possibility is not ruled out that individual batches of this meat, for example, in case of the enforced emergency slaughter of cattle, still remain radioactive. They are proposed for processing at a special unit for radionuclide decontamination, which is now being tested. The meat decontaminated by this method will be fully suitable for preparation of dry feed for cattle.

The situation with milk is analogous. Technology making it possible to obtain a product safe for human health from contaminated milk has been processed and tested. If, we assume, the contamination of whole milk is taken as 100 percent, skimmed milk will have 90 percent, and the cream and sour cream with 20

Fat 70, butter 15 percent, and milk fat 0.6 percent. By using the property of the fat that does not retain radionuclides, we process all the contaminated milk into butter that meets the sanitation norms. An experimental unit is being tested today that fully inhibits radionuclides, which may also be used for cattle fodder. The contaminated remainder, the sorbent, can easily be buried.

[Question] Why are plans to sell agricultural products not taken away from farms located in the constant monitoring zone? After all, it is practically impossible to obtain really clean output there.

[Yu. Khusainov] Nothing is being grown where the contamination level is too high. For example, in Gomel Oblast alone, buckwheat crops have been reduced by 8000 hectares. The plot of legumes, potatoes and vegetables has been cut down considerably, and sheep farms have been eliminated. But tell us, if people are permitted to live, how does one forbid them to work: to grow grain, mow hay and tend livestock? This work will not be in vain. Fulfillment of the recommendations of which I have already spoken guarantees obtaining a safe product.

[Question] These products will, after all, be very expensive. Perhaps it would be more economically advantageous to redistribute funds to grow products on clean land?

[Yu. Khusainov] This is a very complex question, and in the present situation it can hardly be answered unequivocally. Of course, such calculations will be made, and farm specialization will not remain unchanged. Where, however, it touches on the interests of the people, bare rubles cannot be the only counselor. Many peasants do not want to abandon their homes, and it is impossible not to take their wishes into consideration.

[Question] Why can you not find out the extent of contamination of dairy products and meat on the labels? Why do some stores sell meat in packets and, alongside, by weight?

[Yu. Khusainov] Because the product with the content of radioactive substances above the norm is not put out for sale, and there is simply no need for additional markings. Everything that lies on the counters is clean. We cannot repackage an entire product simply because there is not enough packaging equipment and material.

[Question] This is the third year that talk has been going on concerning the fact that equipment with hermetically sealed cabs is needed for field work in the zone, but so far it is not there. When will it finally come?

[Yu. Khusainov] Gosagroprom and the republic government have several times appealed to the union ministries with a request to help in making the work of the machine operator safer. The high offices do not stint on promises, but so far there is no sign of actual assistance. In three years only 825 cabs have been obtained, which is several times less than needed. Indeed, those are without air conditioners. Even the Minsk Tractor Plant can in no way set up series output of the protective equipment.

[Question] The most contaminated milk of all comes from privately owned cows. It is clear: where can a peasant get clean hay? Fodder is still being taken to the farms from other oblasts, and animals from the home-steads eat only what grows in the field beyond the outskirts.

[Yu. Khusainov] Every year we send 3-4000 tons of hay to the stricken rayons for the privately owned herd. This is, of course, not very much. We need to prepare clean

fodder at the site, and to allot safe pastures. It is not for nothing that at the stricken farms, hundreds of hectares of swampy land have been dried out, and the fields are well supplemented with mineral fertilizers. If, however, suitable areas are still not found, you can do nothing, and must give up the cows.

[Question] I heard that when Moscow specialists go to the stricken areas, they take their own food products. What do you do?

[Yu. Khusainov] I have often been and will again be in those areas. I always eat just what the local population does. I take no "spares in a container" with me.

[Question] Is it true that the government agreed to bury the radioactive wastes from the AES on the republic's territory?

[V. Yevtukh] This is an illusion. I must categorically state: the government gave no such permission. These rumors are started by dishonorable people and are calculated for the inhabitant. There are no storehouses of radioactive wastes on the territory of the republic and no one is planning to construct them here.

[Question] The first scientific recommendations for performing agricultural work were given as early as the summer of 1986. Have they changed in consideration of the experience accumulated?

[Yu. Khusainov] In the three years, Gosagroprom has revised the recommendations for performing agricultural work in contaminated areas three times. Each new variant differed qualitatively from the preceding one. Above all, the radiation norms were made stricter. Some of them, particularly on drinking water and milk, were reduced by a factor of 10 and even 100.

#### Will We Lay Asphalt in the Area?

#### The Opinion of a Specialist

V.F. Smirnov, deputy minister of the BSSR Housing-Municipal Operations:

I shall probably not err against the truth if I say that in the early days, the fate of the stricken rayons was decided—earthenware pots. The radioactive houses could be decontaminated or removed, and new ones built, the roads asphalted, the soil stripped. The clean products could even be sent to the stores. The people should have found clean water there, however, on the spot. That is why in the first months after the accident over 3000 wells were decontaminated. Where the open water appeared hazardous for sick people in Bragin, Khoyniki and Narovl by May 30, 11 additional artesian wells were included in the city network. A plant to remove iron at the city water intake in Khoyniki was put into operation. A particularly complex situation formed in Gomel, where after all, half the city drank the Sozh. In an unprecedentedly short time, a new artesian

water intake and water pipeline networks were built, which made it possible to transfer the city fully to underground water supply sources. Additional water intakes were built at other population centers, and now the people can drink water with complete calm on all the contaminated territory.

The question may arise: what will happen to the contaminated water? Quite a bit of it actually remains after the deactivation of structures, roads and equipment. I can inform you that, in conjunction with the BSSR Academy of Sciences, our specialists tested an electrocoagulation unit for radionuclide decontamination of water. An analogous test-experimental unit is already in operation at Khoyniki.

[Question] Peasants in Bragin and Khoyniki are not permitted to eat their own products. What can one buy in the stores there?

[G.Z. Grishchenkov] The population of the stricken villages and settlements are provided with an estimated 180 grams of meat per person per day. We are trying to keep the stores here from having irregularities in the supply of milk, groats and other products. True, it does happen that the store counters are empty. The reason is the lack of transport. There is a particular shortage of refrigerator storage. We send almost the entire available republic specialized transport to the stricken rayons, and indeed, there are not many of these. All the same, this year the shortage of motor transport should be eliminated.

[Question] You said that the inhabitants of the stricken rayons are issued meat, estimated at 180 grams per day, at state prices. I live in Khoyniki and I see no products in the store other than cooperative products. There is even a shortage of eggs and vegetables. Children's preschool institutions are obliged to purchase cooperative meat, because the state gives them none. Can you explain this situation?

[G. Grishchenkov] I can only repeat once again the figures already cited here. Belkoopsoyuz cannot answer for the distribution of products—that is the affair of the local organs. Here is one more thing that must be taken into consideration: according to the norms that I have named, the inhabitants of only those villages and settlements located in the constant monitoring zone are provided for. All the other population centers are supplied according to the ordinary norms.

[Question] I am the chief sanitation physician of Slavgorodskiy Rayon. We have made calculations and feel that for normal supply for the people living in the zone of rigid control, the rayon needs 740 tons of meat. In 1988, 460 tons were obtained. The funds for 1989 have not increased. We cannot ensure full-valued nutrition even for pregnant women and children.

[G. Grishchenkov] To satisfy the demand of the population in the constant control zone of Slavgorodskiy Rayon would take 228 tons of meat products. This much

is allotted, but allowing for the sale of approximately 92 kilograms of tinned meat per person per year. This year this indicator will be 100 kilograms.

[Question] "Clean" milk is sent to 34 population centers in Slavgorodskiy Rayon, but to 94, located in the zone, none.

[G. Grishchenkov] In reality, up to the second half of 1988, the Mogilev oblispolkom determined 34 population centers where dairy products had to be sent. The rayon potrebsoyuz organized the sending of clean dairy products to another 16 centers. So far we can do no more; we do not have enough transport. In this situation, the motor vehicles of local farms and organizations must be more widely utilized to transport products.

[Question] There are schools in which some students obtain free food, and others, none. The children do not understand and do not accept this division into those deserving a free meal and those not meriting it. Can you suggest how the teachers can explain the logic of this situation to the students intelligibly?

A. Fomich, chairman of the BSSR State Committee on Labor:

It is a familiar problem. It is stated correctly, for after all, we are dealing with children. The answer, unfortunately, is so far this: only students who come to a "clean" school from a "contaminated" village receive free food. It is within the competence of the Ministry of Finances and the USSR National Education Committee to change the situation. What sum the solution to this problem will run to is by no means a school task. So far it is not known. But it must be solved.

[Suggestion] The children are the wealth of the nation. They are the most defenseless against radiation. Apparently there is a need to work out a comprehensive program to protect children against the consequences of the accident. A group from the government of the republic, the Belorussian Division of the Soviet Children's Fund and the Society of Mercy simply must do this. The sooner, the better.

[Question] The assertion was made here that the health of not one single person had suffered. Then what is indicated by the double wages and additional pay of 30 rubles for each member of a family living in the constant monitoring zone?

[V. Yevtukh] In reality: the people are fortunately healthy. The additional money paid is for the complexity of the work, for the enforced adherence to certain precautionary measures and finally, for the fact that part of the produce cultivated in the gardens was confiscated. After all, labor was expended, and it should be paid for.

[Question] Why, then, did people not receive additional pay in the contaminated rayons in Mogilev Oblast?

[A. Fomich] The union organs answered the question that we asked by saying that unified norms were established for additional pay for the Ukraine, for Belorussia and for Bryansk Oblast. They were paid out on only one condition: if the contamination level was 15 curies per square kilometer and above. In most of the rayons of Mogilev Oblast, this indicator was lower. This means that with all due respect to the Mogilev residents, we so far can do nothing to help them in this respect.

[Question] Why did Belorussia refuse help from other countries, even though it suffered more than the Ukraine?

[V. Yevtukh] If this help had been offered us, we would have taken it gratefully. We appealed to the union organs and received great support: We were allotted 1 billion, 150 million rubles.

[Question] Volunteers are being sent to the areas of the calamity. Upon returning from there, they are appealing to their trade union committees with a plea to grant them certain benefits. Conflicts are arising. Is it not time to make things clear?

[A. Fomich] Benefits are specified for a small group of people: those who worked not in the contaminated areas in general, but only at the sections settled farther out. As for the priority installation of a telephone for these people, their children being granted places in preschool institutions and housing, these claims are groundless.

[Suggestion] I am Aleksandr Prokopov, chairman of the Braginskiy Rayispolkom. I wish to ask the journalists defending those who voluntarily returned to the evacuated villages, why they make heroes of the "self-made villages." What heroism do they see in the fact that the people, mainly pensioners, undergo risking their far from ideal health? Then the claims arise—something is not there, there is not enough of something else, they have forgotten us, they say. Where can they obtain anything, if all the services—stores, complete receiving centers and even the post offices—in these villages are closed? We do not have enough transport to organize normal supply for those living in the villages, nor are there sufficient funds for the products. I categorically refuse to share the extreme optimism of G. Grishchenkov.

In a word, I propose immediately drawing up legislative acts which would give the right to local Soviets, independently, right up to enforced eviction, to solve these problems. I ask the government of the republic to discuss this proposal, to take it, if necessary, to the union authorities, since this document—and here I am supported by all the soviet workers, without exception, from the stricken rayons—is extremely necessary.

#### The Opinion of a Participant in the Meeting

T.F. Krutovtsova, deputy chairman of the Gomel Oblispolkom:

Almost 40 representatives of our oblast are present at this hall today. We have listened very attentively to everything that the specialists have said, and we understand the anxiety heard in the questions and answers. We are grateful to you for this.

Life, however, presents us with problems related not only to production, but also to the psychological state of the population. It should be said that, despite the measures taken to eliminate the consequences of the accident, no active explanatory work has enabled us to avoid radiation phobia.

Here I should like to address those representatives of creative unions who are present in the hall. I, just as all my colleagues, attentively read the materials from the stricken rayons, which appear on the pages of the newspapers and journals, and impatiently await the television and radio broadcasts. Believe me, the most grateful reader of such publications and viewer of television is the Gomel inhabitant. How annoying it is, though, when journalists see only shortcomings, or else misinform and even frighten the reader and the viewer. After these reports in the newspaper or on television, no information from a specialist can be taken on trust. Let us say, we are informed of the measures taken for a certain problem, and we say that 700 million rubles have been invested in eliminating the consequences of the accident, that an extensive program of health improvement awaits us and that we have a most human government, which does not bargain with its conscience, and they say to us in response: you heard what Ales Adamovich said, and have you really not watched the "Krok" Program?

We should like to see in the journalists, writers and in the cultured figures of our comrades, unanimous thinkers and helpers. We should very much like their public reports to be weightier and better-reasoned, and for them never to forget how their words are echoed.

A few words on problems that affect personnel. The rayons that suffered from the accident are today short about 200 physicians and about 300 nurses. For some reason, though, not a single newspaper has told of the courage and selflessness of those who are working and living there. If such accounts appeared more often on the pages of the newspapers and on television screens, I am sure that the young specialists would be more willing to go to the stricken rayons. So far, in reading the newspapers, people are beginning simply to be afraid of us, the Gomel inhabitants. Even the children who have come from the stricken rayons in Minsk Oblast have been met by some people in respirators and rubber boots. And after all, fear is not a soil on which anything good can grow.

A reproach was heard here to the effect that in Gomel, a year after the accident, children went to the May Day demonstration. This is not true, we had no demonstrations. The main thing for the directors of the oblast has always been to protect the health of the population. And one more thing: The specialists of our oblast themselves

write all the sanitation memorandums on radiation safety for the population. Why do we not have any popular-scientific editions, when after all, the republic has the Academy of Sciences, a multitude of sectorial institutes and many literary forces?

Questions, questions...sharp, impartial, but filled with sincere alarm for the fate of the corners of the earth that are dear to each of us, and for the health of today's and tomorrow's generations. Many of them were asked during this meeting, which continued for almost seven hours. The answers to most of them sounded convincing and weighty. One of the participants in the meeting spoke well of this: "I came here fervently pessimistic, and I left with hope, because I had found out an objective picture of what has happened."

"You will agree that we held an exacting talk, but one useful for everyone," said V.G. Yevtukh, in summing up the meeting. "We could more precisely define the position and direction of the republic and of the public. I think that it will help us to understand each other better, to have greater trust. Of course, we did not go through our discussion without offensive words. It showed once again that all of us must study polemics, the standard of communication and democracy. We are, after all, engaged in one common cause.

"Many suggestions were heard here, which the directors of the ministries and departments should carefully examine and, if necessary, go out to the site, take exhaustive measures to solve the problems and inform the population of them.

"I am sure that today's talk, which was known about by a wide mass of the public, will not only have moral and political significance. It will help in working more efficiently to eliminate the consequences of the accident.

"The participants in the meeting were unanimous on the fact that the ministry and department workers should go more often to the stricken rayons, the inhabitants of which are awaiting answers, not to global, but to simple, vital questions, determining their vital tonus today, their faith or lack of faith in tomorrow and their working mood."

536.248.2

**Method of Calculating True Steam Content by Volume in Reactor Unit Components During Strong Leakage**

18610178 Tbilisi SOOBShCHENIYA AKADEMII  
NAUK GRUZINSKOY SSR in Russian Vol 131 No 2,  
Aug 88 pp 369-372

[Article by N. A. Kevkhushvili and M. Sh. Loladze, Georgian Polytechnic Institute imeni V. I. Lenin; presented by Academician V. I. Gomelauri on 3 Apr 1987]

[Text] The true steam content by volume must be calculated when analyzing the emergency operating modes of water-cooled, water-moderated power reactors

when the seal on their main circulation pipeline fails. The position of the true level and the steam content at the inlet to the discharge line largely determine the critical flow rate of the water-and-steam mixture through the break site, the dynamics of the pressure differential in the component under examination, the coolant level at the end of the process, and the heat exchange crisis on the heat-distributing surface.

Several methods of solving this problem have already been developed.<sup>1,2</sup> The theoretical model presented<sup>2</sup> makes it possible to calculate the distribution of the steam content by volume along the height of the component, both in the presence of internal heat sources and in their absence. During the mathematical formulation of the problem it was assumed that both phases in the system are in an equilibrium state, that the pressure at both points is identical, and that the true steam velocity is constant throughout the height of the volume. It has been shown that, in the case of small leakages where the fluid may be assumed to be stationary, the distribution of the true volume of steam along the component's height is subordinate to the equation

$$\varphi(z) = \left[ 1 - \frac{Q(\tau) v'}{\frac{di'}{dT} \frac{dT}{d\tau} V_d} \right] [1 - \exp(B \cdot z)],$$

where

$$\text{где } B = \rho' \frac{di'}{dT} \frac{dT}{d\tau} / (\rho'' w'' r);$$

$Q(\tau)$  is the power of the internal heat sources;  $\rho'$  and  $\rho''$  are the densities of the fluid and steam, respectively;  $r$  is the specific steam formation heat;  $i'$  is the specific enthalpy of the saturated fluid;  $w''$  is the true velocity of the steam phase;  $V_d$  is the volume of the diphasic mixture;  $T$  is the temperature; and  $\tau$  is the time.

Equation (1) was used as the basis for developing an algorithm to calculate the thermohydraulic parameters of the coolant when a high-pressure vessel's seal fails.<sup>2</sup> The results of the numerical solutions of the differential equation system thus derived were found to be in good agreement with the existing experimental data.

The discrepancy between the results calculated by the previously developed method<sup>1,2</sup> and the experimental data that occurred when the leakages were large was caused by the incorrectness of the assumption concerning the quasistationary movement of the phases. In other words, determining the steam velocity  $w''$  at large leakage diameters is a complicated problem in view of the significant unevenness of the distribution of velocities along the vessel's cross section and because of the absence of any stabilization of the volume flow of steam along the height in the initial stage of the coolant discharge. To overcome this difficulty, we will integrate

equation (1) within the bounds of the diphasic mixture and will assume that, in the case of large leakages, the effect of the heat supply  $Q(\tau)$  on the change in the coolant's thermohydraulic parameters is insignificant throughout the entire course of the process.<sup>3</sup> As a result, we obtain the following expression:

$$\frac{1}{B} (e^{B \cdot H_y} - 1) = H_y (1 - \bar{\varphi}_d), \quad (2)$$

where  $H_y$  is the height of the diphasic mixture and  $\bar{\varphi}$  is the average value of the steam content in the diphasic region.

It is not possible to specify the coefficient  $B$  in elementary functions from expression (2). Therefore, we will rewrite (2) in the following form:

$$e^{B \cdot H_y} - 1 = B \cdot C,$$

where  $C = H_y(1 - \bar{\varphi})$ , and we will make the following substitutions:

$$x = B \times H_y,$$

$$a = C/H_y.$$

We will then ultimately obtain

$$e^x - 1 = ax. \quad (3)$$

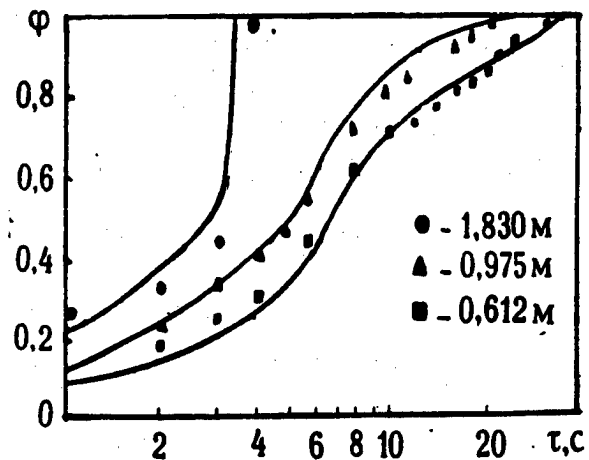

Figure 1. Comparison of the Calculated Distribution Curves of the Steam Content by Volume in a Bundle of Heaters at Different Marks Along the Vessel's Height With Experimental Data.<sup>3</sup>

$$d_T^H = 0025 \text{ m}$$

The parameter  $\alpha$  varies from zero to unity. Consequently, the solution of function (3) in this range has the following appearance: a) when  $\alpha$  is greater than or equal to 0.9 but less than or equal to 1, the solution may be represented in the form of a power series

$$x = 2(\alpha - 1) - \frac{4}{3}(\alpha - 1)^2,$$

b) in the case where  $\alpha$  is greater than 0 but less than or equal to 0.1, equation (3) is solved by using the asymptotic series

$$x = -\frac{1}{\alpha} + \frac{1}{\alpha} e^{-1/\alpha},$$

c) in the interval 0.1 is greater than  $\alpha$  is greater than 0.9, the result is calculated in accordance with Newton's method

$$x_{n+1} = x_n - \frac{f(x_n)}{f'(x_n)},$$

where  $f(x) = e^x - 1 - \alpha x$ .

For the sake of the reliability of the determination of nature of the distribution of the steam content throughout the vessel's height in the calculation model assumed, Figure 1 presents a comparison of the calculated and experimental results.<sup>3</sup>

It is evident from the comparison that, overall, the proposed method of calculating the true steam content by volume allows for the complex dynamics of the state of the diphasic mixture in the vessel during a pressure discharge and yields a close coincidence with experimentally obtained results.

#### Bibliography

1. Avdeyev, A. A., and Avdeyeva, A. A., *TEPLOENERGETIKA*, No 8, 1980, pp 53-57.
2. Demytyev, B. A., Kevkhishvili, N. A., and Gemega, B. V., *TEPLOENERGETIKA*, No 2, 1987, pp 37-41.
3. Kevkhishvili, N. A., and Demytyev, B. A., *TEPLOENERGETIKA*, No 7, 1985, pp 67-70.
4. Vaynberg, M. M., and Trelogin, V. A., "Teoriya vetvleniya resheniya nelineynykh uravneniy" [Theory of Branching Solution of Nonlinear Equations], Moscow, 1969, 326 pages.

UDC [621.311.25:621.039].001.24

#### Calculation-Experimental Determination of Radiation Heating of Elements of Interreactor Monitor of VVER-440

18610176a Moscow ELEKTRICHESKIYE STANTSII  
in Russian No 6, Oct 88 pp 9-11

[Article by engineer A. S. Zakharov, engineer S. A. Andrushechko, engineer Ye. N. Videnyev, engineer V. P. Pavlenko, engineer Ye. G. Popovich, Candidate of Technical Sciences Yu. N. Pytkin, engineer M. V. Panin, Candidate of Technical Sciences S. O. Slesarevskiy, engineer V. I. Tkachenko, and engineer V. I. Lobov, VNIIAES, IYal AN Ukrainian SSR, and Kola AES]

[Text] One of the most important operating parameters of the VVER-440 are the thermal capacities of the reactor plant (RU) and of the fuel assemblies (TVS), for evaluation of which a VVER-440 type reactor is supplied with the following thermal sensors: thermocouples of the interreactor monitoring system ("mass measuring"), thermocouples in the mixing chambers, and thermocouples located in the "hot" and "cold" runs of the circulating loops.

The interreactor monitoring system (SVRK) of the VVER-440 is a complex measuring system. All the primary coolant temperature monitoring sensors at the outlet from the fuel assemblies of the reactor core are divided into 12 groups, each of which is connected through a communication line to an individual compensation box with resistance thermometer. Information is extracted from the thermocouples through converting links (measuring channels) in the form of a "mass measuring" temperature field. The measuring channel is understood as a circuit of elements and devices: a primary converter, switching, normalization and transformation device, communication lines, analog-digital converter, computer system, data display and so on.<sup>1</sup>

It is known that radiation capture of neutrons and absorption of gamma-quanta cause release of heat in the structural materials of a nuclear power plant (YaEU). This phenomenon is usually called radiation heating of the nuclear power plant materials.

Similar heating is also observed in the elements of the intrareactor monitoring system, subject to the effect of these same types of radiation. Radiation heating has the greatest influence on the readings of the "mass measuring" thermocouples, which record the coolant temperature at the outlet from the fuel assemblies of the reactor core.

Radiation heating of the thermocouples results in the fact that the SVRK readings increase the real temperatures somewhat. The error introduced by radiation heating in the readings of the thermocouples that monitor the

coolant temperature at the outlet from the fuel assemblies permits more reliable information on heating of the coolant in the fuel assemblies of the core.

Ensuring the reliability of the given information is especially timely for VVER-440 reactors, in which model fuel assemblies (cartridge shields) are used to reduce the fast neutron flux in the reactor vessel.

If the rated reactor capacity is maintained, replacing part of the operating fuel assemblies by model assemblies results in an increase of the available power of the fuel assemblies to values close to maximum and, accordingly, in an increase of heating of the coolant in the fuel assemblies to the maximum permissible values.

An increase of the accuracy of determining the heating of the coolant in the fuel assemblies ( $\Delta T_{TVS}^i$ ) permits one to solve several important operating problems:

to correct the existing restrictions of the thermal capacity of the reactor with respect to an excess of settings  $\Delta T_{TVS}^i$  with regard to radiation heating of the SVRK thermocouples;

increase the accuracy of tracking the energy release fields in the core, which reduces the error of determining the burnup fraction of the nuclear fuel.

There is a principal possibility of determining the error of the readings of the thermocouples which register the coolant temperature at the outlet from the TVS due to radiation heating by statistical processing of data delivered by the standard temperature monitoring system.

The basis of this processing is the method of comparing the readings of thermocouples, installed at the coolant outlet from the fuel assembly ( $T_{TVS}^{vykh}$ ), to the readings of the thermocouples, installed in the "hot" runs of the circulating loops ( $T_{g \times n}^i$ ). It should be noted that the temperature of the coolant, flowing through the labyrinth packing, interassembly gaps and so on, affects the value of  $T_{g \times n}^i$ . However, as calculations showed, these factors cause changes of the value of  $T_{g \times n}^i$ , that do not exceed the accuracy of determining the extent of radiation heating.

When determining the accuracy of measuring the extent of radiation heating of the "mass measuring" thermocouples ( $\Delta T_{r,r}$ ), one must take into account the presence of errors in determination of coolant temperature at the outlet from the fuel assemblies of the reactor core and in the "hot" runs of the circulating loops. Errors in determination of the coolant temperature are caused by:

an error in determination of the temperature of the thermocouples themselves;

an error introduced in determination of temperature by the main structural elements of the measuring channels;

an error of the main modules of the IV-500 MA machine;

the accuracy of calibration of the measuring channels;

the difference of manufacture of the thermocouples with regard to the effect of technological tolerances of the structural elements of the reactor;

the difference of manufacture of the fuel assemblies, related to the technological tolerances during their production;

the presence of coolant leaks through the interassembly gaps, escaping the fuel assembly;

the number of measurements made, i.e., by the variation of the error in determination of temperature in the presence of the general combination of values of the measured temperatures with given fiducial probability compared to one-time temperature measurement.

To increase the accuracy of the results in calibration of the SVRK readings, a specially developed method of checking the reliability of temperature measurements was used.<sup>2</sup> The essence of the given method includes determination of the coolant temperature of the primary circuit by determining the true value of the working substance pressure of the secondary circuit by using standard pressure gauges, installed in the main steam header (GPK), under conditions of thermodynamic equilibrium between the primary and secondary circuits of the nuclear steam generating plant (YaPPU) on MKU.

One of the factors that directly influences the temperature measurement error at the outlet from the fuel assemblies is the thermal resistance of the air gap between the technological sleeve and the thermocouple, which can occur when the thermocouple does not fit to a standard location. The thermal resistance of the air gap between them is added to the natural thermal resistance of the thermocouple and the sleeve wall. It was determined as a result of analysis of all the possible variants of installing temperature detectors in the process channels that the radiation correction upon deviation of setting the sensors from the standard value increases in most cases, but is always greater than the minimal radiation correction.

A number of calculation-experimental studies were completed to determine the extent of radiation heating of the "mass measuring" thermocouples in the VVER-440 reactor.

Main attention was devoted to study and processing of cartograms of the temperature fields, which correspond to the operation of the reactor at rated capacity. At the same time, a number of cartograms at intermediate levels of reactor capacity (30, 50 and 80 percent of rated capacity) and at the minimum monitorable level of capacity were analyzed to obtain a qualitative pattern and to confirm the fact that the value to be determined is that of the radiation heating.



The algorithm for processing the cartograms included:

<sup>3</sup>Determination of the mean coolant temperature in the "cold" runs of the circulating loops ( $T_{kh,n}$ );

discarding the readings of the thermocouples at the coolant outlet from the fuel assemblies ( $T_{vskh_{tvsj}}$ ) of the core according to the following criterion: the temperature to be recorded by the thermal sensor above the assembly is less than the average temperature of the primary circuit;

correction of the mean coolant temperature at the outlet from the core with regard to the mean suspended coolant temperatures at the outlet from a group of symmetrical fuel assemblies;

determination of the mean coolant temperature in the mixing chambers.

The mean value of coolant temperature at the outlet from the fuel assembly was compared to the mean value of the coolant temperature in the "hot" runs of the circulating loops. The difference of these values will also be the mean value of the radiation heating of the standard thermocouples of the intrareactor monitoring system to be studied.

The error of measuring the coolant temperature at the outlet from the fuel assembly of the reactor core, caused by radiation heating of the materials of the "mass measuring" thermocouples, was determined as a result of conducting special calculation-experimental studies on the power-generating units of the Kola AES. When the VVER-440 reactor is operating at rated capacity, the extent of radiation heating of standard TKhK-0665 thermocouples is in the range of 1.0-2.8°C.

When the reactor is operating at MKU, the extent of radiation heating is approximately equal to zero, while the values of radiation heating at levels of reactor capacity of 30, 50 and 80 percent of the rated value comprises 0.8, 0.9-1.4, and 1.3-1.5°C, respectively.

Using the methods of mathematical statistics, based on the axioms of Gauss theory<sup>4, 5</sup> (the probability of random errors appearing is a decreasing function of their value; random errors equal in absolute value, but opposite in sign, are found rather frequently) it was proved that the error of determining the extent of radiation heating, with fiducial probability of P equals 0.90, comprises a value of no more than plus or minus 0.4°C.

The mean square error of the mean value was used when calculating the error of determining the extent of radiation heating of the "mass measuring" thermocouples at the coolant outlet from the fuel assemblies.

The results are in good agreement with the previously determined experimental values of radiation heating for similar "mass measuring" thermocouples.

## Conclusions

1. The minimal correction for radiation heating is determined for "mass measuring" thermocouples, which comprised 1.4°C when the reactor is operating at rated capacity.

2. The error of determining the extent of radiation heating during the studies was plus or minus 0.4°C with fiducial probability P equals 0.90.

3. The value of the correction for radiation heating of the "mass measuring" thermocouples is directly proportional to the capacity of the reactor plant.

4. The use of the results of the studies permits one to make changes with regard to the radiation heating of SVRK thermocouples to the existing restrictions of the thermal capacity of a VVER type reactor, related to an excess of settings with respect to coolant heating in the fuel assemblies.

## Bibliography

1. Ignatenko, Ye. I., S. A. Andrushechko, Yu. N. Pytkin et al., "On Increasing the Reliability of Interreactor Monitoring," ELEKTRICHESKIYE STANTSII, No 1, 1986.

2. Deshchenya, N. T., and Yu. N., Pytkin, "Method of Certifying the Measuring Channels of Information Computer Systems," ELEKTRICHESKIYE STANTSII, No 11, 1984.

3. Deshchenya, N. T., Yu. N. Pytkin, and M. V. Panin, "Method of Checking the Reliability of Temperature Measurements During Operation of VVER Reactor" ELEKTRICHESKIYE STANTSII, No 10, 1986.

4. Shenk, Kh., "Teoriya inzhenernogo eksperimenta" [Theory of Engineering Experiment], Moscow, Izdatelstvo "Mir", 1972.

5. Yakovlev, K. P., "Matematicheskaya obrabotka rezultatov izmereniy" [Mathematical Processing of Measurement Results], Moscow, Gosizdatelstvo tekhnicheskoy literatury, 1953.

COPYRIGHT: Energoatomizdat, "Elektricheskiye stantsii", 1988

UDC [621.311.25:621.039]:620.197

**Corrosion Protection at Crimean AES**  
18610176b Moscow ELEKTRICHESKIYE STANTSII  
in Russian No 6, Oct 88 pp 11-13

[Article by V. G. Shigorin, Candidate of Technical Sciences, A. G. Volnistov, engineer, V. I. Tanskiy, Candidate of Technical Sciences, S. N. Borzov, engineer, A. P. Naumov, engineer, N. I. Fomina, engineer, A. I. Korilov, engineer, B. I. Stolnik, engineer, and M. P. Omelchenko, engineer, Scientific Research and Design Institute of Erection Technology and Crimean AES]

[Text] Research work in design of the Crimean AES showed that the corrosion situation at the plant was determined, on the one hand, by the use of water from

the Sea of Azov in the turbine cooling system, and on the other hand, by the salinity of the soil in this region.

Water from the Sea of Azov contains chloride and there are 6.2-7.6 g/liter of chlorides in it with a total salt content of 13.8-14.0 g/liter. With regard to ground waters, they are also very aggressive, containing chlorides-sulfates with total salt content of approximately 26 g/liter and average sulfate content of 3.8 g/liter.

The rate of both sea and soil corrosion was estimated under these conditions by a value of 0.18-0.20 mm/year, while that in a flow was estimated at 1-2 m/s up to 0.23 mm/year.

The operating conditions of those pipelines of the commercial water supply system of the plant, which are subject to intensified corrosion both outside and inside, are especially unfavorable. These pipelines include the sea water intake, immersed in the Sea of Azov, and also the system of circulating pipelines, laid in the soil and which pumps sea water. The total rate of corrosion of the walls of these pipelines may reach 0.4-0.5 mm/year on both sides.

Under these conditions, with a design thickness of the walls of the pipelines of 10-14 mm, their operating life can be limited to 7 years with two-sided corrosion aggression and to 13 years with one-sided aggression, which is clearly insufficient.

Reliable anticorrosion protection of both the inside and outside surfaces of the plant pipelines was required in the resulting situation.

A search for reliable anticorrosion polymer coatings, resistant to the effects of waters of the Sea of Azov and ground waters in the region of the Kazantipskiy zaliv, was begun at the Crimean AES with regard to the experience, accumulated during construction and operation of the commercial sea water supply systems (Caspian water) at Shevchenko<sup>1</sup>, at the sea circulating and other pipelines (Baltic water) of the Leningrad AES imeni V. I. Lenin<sup>2</sup>, and of the circulating water pipelines of the Ignalina AES and other facilities.

Experience<sup>1, 2</sup> and theoretical studies<sup>3, 4</sup> showed that anticorrosion polymer coatings of the adhesion-inhibiting mechanism of protective action, meet the requirements of high reliability and durability to the maximum extent in water corrosion media. These coatings (composites), having surface activity, interact with the surface of the metal to be protected, block its active centers, and thus transform the metal to the absorption-passive state. The anticorrosion coatings, selected and directionally modified with respect to specific operating conditions, are capable of maintaining for a long time (years) the passive stage of the metal to be protected, preventing corrosion of steel structures, pipelines and equipment.

Epoxide-pit coal composites, additionally modified by adsorption-active modifying additives, and reinforced coatings of the same type for protection of the outside surface of pipelines against soil corrosion, were studied with respect to the anticorrosion protection of the commercial water supply system, including the sea system, at the Crimean AES.

A number of epoxide-pit coal composites, which included modifiers with acetylene end bonds, heterocyclic, nitrogen- and sulfur-containing compounds, materials with nitrile, isocyanate and other groups, capable of forming donor-acceptor coordination bonds with the metals, were studied by the method of taking the anode potentiodynamic I-E curves<sup>3</sup>.

These studies permitted us to judge the adsorption-inhibiting effect of the anticorrosion composites to be studied. It was established that a stable region of passivation of the iron electrode by the absorption layer and accordingly a significant decrease of the rate of anode dissolution of the metal are observed over a wide range of voltages (from 0.7 to 0.2 V).

These results of study of coatings, formed of epoxide-pit coal composites, permitted us to predict their increased adhesion to metals, high protective properties, and durability. Comparison to an epoxide-pit coal coating of type (SP-EK-4)<sup>5, 6</sup> permitted us to predict the service life of the selected EP-81-21 and EP-81-22 modified epoxide-pit coal coatings under real (sea) operating conditions of the pipelines of more than 20 years.

The results of electrochemical studies were fully confirmed by laboratory data and full-scale tests. The following have the best strength characteristics: azole-modified EP-81-21 epoxide-pit coal coating and another EP-81-22 coating based on this, hardened with a KI-1 ketamine hardening agent with participation of the moisture from the air.

Laboratory tests of the coatings in waters of the Sea of Azov, accelerated by a temperature rise (50-90°C), confirmed the reliability of these coatings. Specifically, such a criterion as the electric resistance of the coatings after 900 days exposure in hot sea water varies by only two orders of magnitude—from 10<sup>11</sup> to 10<sup>9</sup> ohms, which characterizes the high protective ability of these coatings. Externally, no breakdown of any kind was observed on EP-81-21 and EP-81-22 coatings, while the steel substrate under the coating had no traces of corrosion.

Full-scale tests of a series of coatings were continued for more than 5 years on stands in waters of the Sea of Azov. The results correlate fully with the results of laboratory tests and confirm them.

Thus, the combination of tests confirmed the correctness of the direction for use of coatings of the adhesion-inhibiting mechanism of the protective effect for anti-corrosion protection of the sea commercial water supply pipelines of the Crimean AES.

Epoxide-pit coal coatings of marks EP-81-21 and EP-81-22 were recommended for corrosion protection of these pipelines. Because of the presence of azole in the primary modifier, it has increased protection ability. EP-81-22 coating, due to the use of modified KI-1 ketamine hardening agent, is not inferior to the first compound in protective properties, but is capable of forming under conditions of increased moisture content of the air (up to 100 percent), for example, during the fall-spring seasons, retaining the initial anticorrosion capability.

The optimal thickness of one or another coating for internal production of the pipelines is 400  $\mu\text{m}$ . The coatings were additionally reinforced with glass fabric of mark T-11 in two plies to reinforce the mechanical strength of the anticorrosion protection of pipelines, laid in the soil without trenches. The total thickness of this reinforced coating was 700-1,000  $\mu\text{m}$ .

The results of the studies found practical realization during construction and installation work at the Crimean AES. The corresponding technological instructions TI 054-85 (for EP-81-21 coating) and TI 012 (for EP-81-22 coating) were published to assure introduction of the recommended systems of coatings.

The work was performed directly on the construction site with recruitment of a specialized organization for anticorrosion work in spaces specially allocated for this work.

The water lines were delivered to the anticorrosion work site in the form of shells (runners) up to 12 m long, which were placed on transport carts and were delivered to the surface preparation section, which was achieved by the metal shot method.

After metal shot cleaning, the shell with nondusty surface was delivered to the painting station, where layers of anti-corrosion composite with the required intermediate drying until the given total thickness of the coating was reached were applied in sequence by pneumatic spraying.

The pipeline is additionally wound with glass fabric with overlap by 50 percent when the outside surface of the pipeline is protected against soil corrosion after the optimal thickness of the coating has been reached (400  $\mu\text{m}$ ). Thus, a two-ply winding with glass fabric, impregnated with epoxide-pit coal composition, is obtained over the entire surface. A last impregnation-separating layer of the same composition was finally applied by pneumatic spraying. The protection of the pipeline is

completed with this. The joints between sections were protected under field conditions at the installation site with provision of all requirements of the technological instructions.

As the experience of work in anticorrosion protection of water lines at the Crimean AES showed, the recommended EP-81-21 and EP-81-22 coatings are sufficiently technologically effective under construction and installation conditions, while EP-81-22 coating is also technologically effective under conditions of increased moisture content during the fall-spring seasons, which considerably reduces the effect of seasonality on performance of anticorrosion work.

As a result, a large volume of anticorrosion work has been completed that exceeded 63,000  $\text{m}^2$ , including more than 29,000  $\text{m}^2$  reinforced coatings, and more than 11,000  $\text{m}^2$  of EP-81-22 coatings under conditions of increased moisture content. This made it possible to prevent intensive internal and external sea and soil corrosion of the branched commercial water supply pipeline system, including a sea supply system, of the Crimean AES.

The latter was expressed by a total actual saving of more than 1.5 million rubles, of which the main volume of work was completed only in 1985, and an actual saving of 1.16 million rubles was achieved.

#### Bibliography

1. Shigorin, V. G., I. Yu. Molotov, M. S. Lukoyanov, and L. I. Buzina, ZASHCHITA METALLOV, 1986.
2. Shigorin, V. G., "Anticorrosion Coatings in the Nuclear Industry and in Power Engineering," deposited at VIMI, 31 March 1980, No. D 04170.
3. Shigorin, V. G., ZASHCHITA METALLOV, Vol 21, No 1, 1985.
4. Shigorin, V. G., N. I. Fomina, M. S. Tarasevich, and V. A. Bogdanovskaya, ZASHCHITA METALLOV, Vol 18, No 4, 1982.
5. USSR Inventor's Certificate 306154, BYULLETEN IZOBRETENIY, No 19, 1971.
6. Shigorin, V. G., M. I. Kamayev, and B. N. Yegorov, LAKOKRASOCHNYE MATERIALY I IKH PRIME-NENIYE, No 1, 1971.

COPYRIGHT: Energoatomizdat, "Elektricheskiye stantsii", 1988

UDC  
[621.311.25:621.039]:[621.313.322+621.314.21].001.4

**Integrated Startup Tests of 1,000-MW Generator-Transformer Module of AES**  
18610176c Moscow ELEKTRICHESKIYE STANTSII  
in Russian No 6, Oct 88 pp 13-17

[Article by V. A. Kolychev, engineer, Ye. V. Savchenko, Candidate of Technical Sciences, M. A. Stepa, engineer, and A. P. Shapoval, engineer, MMU of Elektroyuzhmontazh Trust]

[Text] The order and results of tests of an AES unit with capacity of 1,000 MW, completed according to the diagram shown in the figure, with four-pole turbogenerator having switching apparatus in the stator circuit, a brushless excitation system with excitation winding powered through rectifier transformer TE (group of single-phase rectifier transformers of 24/0.38 kV), and with integration of relay protection, carried out according to the standard scheme, are considered in the article.<sup>1</sup>

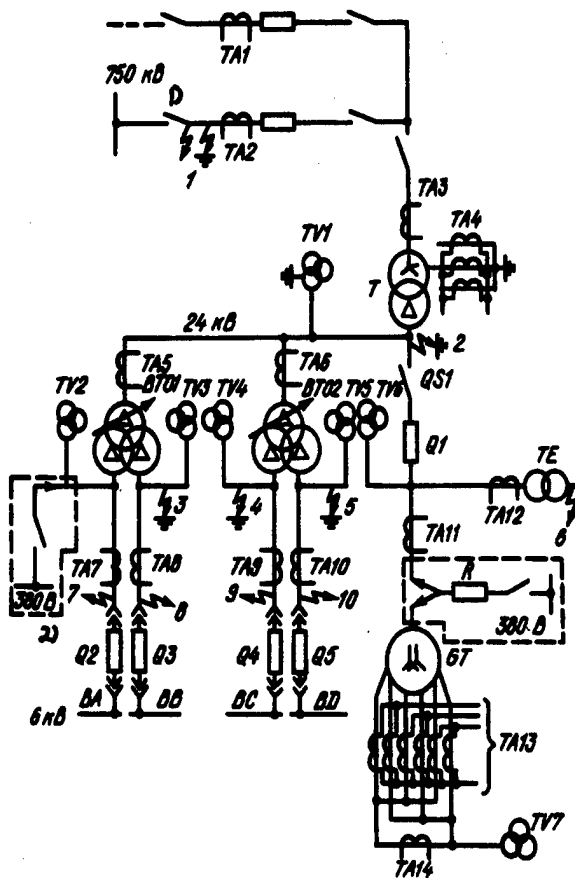

Key: 1. kV 2. V

The correctness of joining all the power circuits of the main circuit of the unit, the current and voltage circuits, the correctness of connecting the safety devices, automation and measuring devices, and the short-circuiting characteristics of the unit and the no-load characteristics of the generator are taken during integrated startup tests. The entire test complex contains three phases, performed directly before startup of the turbogenerator, during its rotation at no-load (beginning with the turn) and in the load modes after the generator is connected to the network.<sup>2</sup>

Pre-start phase. The first phase, the pre-start phase, is divided into two parts: check of devices and circuits. A check of the safety, automation, control and measurement devices includes a check of the correctness of fulfillment of the characteristics and, specifically, of the settings of the relay protection, after installation of the devices on the boards. It is executed by delivery of current and voltage to the terminal rows of the boards. Along with checking the correctness of the settings, this permits one also to check the intraboard installation of the current and voltage circuits and to check the interaction of the logic safety, control and signalling circuits.

During the second part of the pre-start phase of the check, current and voltage were delivered to the power circuits of the unit and were measured in the current and voltage circuits, by which the correctness of installation of the power and check circuits was checked.

Thus, the pre-start phase of tests provides reliable information on the readiness of the circuits and devices of the unit for start-up tests in an operating generator, in the volume of which a check of the circuits and settings of the relays are not provided.

A check of the current circuits of TES units by personnel of the adjustment-installation control of the Elektroyuzhmontazh Trust is completed on the basis of using low-frequency currents, flowing under the effects of residual magnetization upon rotation of the turbogenerator by a shaft-rotating device.<sup>2, 3</sup> However, a shaft-rotating device with very low rotational frequency (one revolution every 6-10 min), in which it is difficult to register current, was used in the turbounits of an AES with rated rotational speed of 1,500 min<sup>-1</sup>.

In this regard, the program of the pre-start circuit check phase was designed on the basis of delivery of current from a permanent voltage source of 380 V, connected alternately to the turbogenerator leads and to the transformer circuits in the cross-cut between the turbogenerator leads and conductor, formed by removal of the connecting compensators for testing the conductor insulation. The current of the test mode is limited to a value of 200-240 A by inclusion of resistors R with resistance of 1 ohm in each phase to reduce the capacity of the source and to prevent dangerous heating of the uncooled rotor. The resistor of the transformer T (group of single-phase transformers of 1,251 MV times A, 24/787 kV)

and of a fixed turbogenerator GT (1,000 MW, 24 kV, 26,730 A, 1,500 min<sup>-1</sup>) may not be taken into account in the calculation estimate. Resistance KZ of transformer BT01 (BT02) is approximately 1.1 ohm and reduces the current by approximately a factor of 1.5 (BT01 and BT02 are the working transformer of 63 MV times A, 24 plus or minus 2.88/6.3/6.3 kV).

The voltage circuits were checked at two voltage levels: 1.6 and 6 percent of the rated value. In the first case, a voltage of 380 V was fed to the same point as during a check of the current circuits of the transformers, i.e., toward 24 V, and in the second case, toward 6 V to cell TV2, for which a power cable for current of 40 A is provided.

Stationary elements of the excitation system were used in assembly of the test circuit: adjusting line of 380 V, resistors, shunting winding of the rotor, and connecting cables. Cable was also laid that connects the resistors to the generator leads, and a jumper was also installed between the excitation assembly cabinets and the connections between the resistor modules were reinstalled.

Three- and one-phase short circuiting was created at point 1 by connection of three or one phase, respectively, of a 750-kV grounding circuit breaker, and at point 2 by connection of single phase of a 24-kV grounding circuit breaker.

Single-phase short circuits at points 3-5 were executed in cells TV3-TV5 (TV1, TV6 are voltage transformers of

$$\frac{24\,000}{\sqrt{3}} / \frac{100}{\sqrt{3}} / \frac{100}{3} \text{ V, TV2-TV5-TT } \frac{6000}{\sqrt{3}} / \frac{100}{\sqrt{3}} / 100 \text{ V,}$$

and TV7-one phase TT  $\frac{24\,000}{\sqrt{3}} / \frac{100}{\sqrt{3}} / 100 \text{ V}$  by ordinary check conductors.

Three-phase shorts at points 6 and 7-10 were calculated for a current of 200 and 300 A, respectively. To reduce the current from the power supply and to increase the current in the circuits of each of the transformers, the short-circuiting at points 1, 6 and at pairs 6, 7 and 9, 10 were performed alternately. A jumper for a current of 20 A was installed on the brush apparatus or directly on the protective rings of the rotor to eliminate voltage in the turbogenerator excitation circuits.

The values and angles of currents and voltages were measured by using a voltamperphase meter, having lower range of scale of 10 mA.<sup>1</sup> This measurement can be made by using a serial instrument of type VAF-85, supplied with an additional amplifier accessory.

When a current of 220 A was delivered toward the turbogenerator, the current in the rotor jumper was approximately 10 A, while that in the current circuits was 73 mA; the current in the bus currents circuits of 24

kV was 37 mA when current was fed toward transformer T and was 3.3 mA in the transformer circuits of winding current of 750 kV; it was 5.8 mA after assembly of these circuits into a triangle, to which a current of 6.7 A in the 750-kV winding corresponds.

The currents in the zero sequence filter of current transformer TA4 and in zero conductors of circuits TA2 and TA3 are checked in the one-phase short-circuiting mode at point 1. The group of connection of transformer T and phasing of its circuits is also checked. The current in this mode at 750 kV of T comprised 11.6 A, while that in circuits TA2-TA4 comprised 5.8 mA.

No. of TV in circuit	Number of groups in each No.	Rated current, A	
		primary	secondary
1-4	5	2,000	1
5-10	2	3,000	5
11	7	30,000	5
12	1	400	5
13	3	15,000	5
14	2 single-phase	1,500	5

It is sufficient to perform short-circuiting in the test circuit at only one point of 750 kV, if the mutual phasing of the current transformer circuits TA1 and TA2 was completed earlier, for example, by the working current of connections of 750 kV to startup of the unit. Otherwise, a short-circuiting check must be performed in the current transformer circuit TA1 as well.

TA1-TA14 in the circuit in the figure are the current transformers with parameters presented in the table.

The following currents (in amperes) were produced at points 6-10 during short-circuiting:

	BT01 (BT02)	TE
In power circuit:		
BH	140	2.5
HH	250	150
In current circuit:		
BH	0.23	0.031
HH	0.41	—

The current circuits of gate winding TE were checked during load tests of thyristor converters.

The currents in transformer circuits BT01 and BT02 were sufficient for confirmed phasing of the differential protections of these transformers.

The zero leads of current transformer circuits TA5-TA13 are checked by measuring the currents in them upon brief shunting of one phase on terminals, close to the current transformer.

One half-phase was disconnected at the point of assembly of the neutral to check the transverse differential protection circuit of the generator (current transformer TA14).

As stipulated earlier, the voltage circuits are checked at two levels of voltages, delivered to the transformers of the unit. The desirability of this duplication is determined by the fact that weakening of the contacts both in the power and in the check circuits are better determined at voltage of 1.6 percent of the rated value, while more reliable adjustment from noise can be achieved at voltage of 6 percent.

A check at the first voltage level requires fewer time expenditures, since the power circuit of the previous current check is fully used for it. Single-phase voltage of 220 V is delivered to the 24-kV circuits to check the winding circuits, connected to the open triangle, and circuits TV7, before the stator winding is connected by one of the phases to the remaining 24-kV circuits of the temporary jumper from the check lead.

The vector and potential diagrams of the 6- and 24-kV voltage circuits are taken when 380-V voltage is delivered toward 6 kV, the synchronization circuits are checked, and the currents in the circuits of the device for checking the insulation of the 750-kV leads of type KIV-500 are measured during symmetrical and asymmetrical power supply. The current of the feed source was 14-21 A in different phases in the tests.

One-phase shorts in currents 2-5 are carried out in the power mode in the direction of 6 kV to check the circuits of windings TV3-TV5, connected to the open triangle, and also circuits TV7.

Installation of a ground to TV2 is impermissible, since it creates a short circuit in the 380-V power system, having a grounded neutral.

The power circuits and voltage circuits of the 6-kV sections BA-BD and their working leads from transformers BT01 and BT02 (voltage transformers TV2-TV5) are phased earlier even at the stage of preparation of the 6-kV sections to first delivery of voltage from the standby source.

A reduced voltage of 380 V is delivered to the sections and the off switches of working leads Q2-Q5, the connections of which to the external leads have been disconnected, are also switched on.

Supercontact resistors of the generator were determined by the two-phase power supply method through three pairs of phases alternately by using the test circuit.<sup>4</sup>

Voltage was delivered to the resistor both through the limiting resistor R and without it to determine the effect of current on the resistor. The current was approximately 170 and 800 A, respectively. The value of  $X^{\text{double prime}}_{\text{reset}^d}$  was 0.18 and 0.1865 ohm or 0.347 and 0.3981 relative units, respectively, at these currents, which is 9 and 12.6 percent higher than the calculated value, equal to 3.18 relative units. The value of  $X^{\text{double prime}}_q$  at the indicated currents was 0.21 and 0.2124 ohm or 0.406 and 0.41 relative units, respectively. The total resistance and reactance differed by approximately 1 percent in all cases. The results indicate that the supercontact resistances of large-capacity turbogenerators can be determined at small currents without regard to the active component, i.e., without resorting to a wattmeter.

Before determining the supercontact resistances, one must ascertain the presence of current in the short, installed on robot rings. There may be no current due to the absence of contact on the freely protruding wedges in the assembly for connection of the turbogenerator and exciter shafts. The circuit can be restored by rotating the shaft with a shaft-rotating device.

A short-circuiting experiment on only one of the secondary windings of transformer BT01 showed that the mutual influence of the modes of these windings is very low. The voltage on the free winding decreased by only 7.4 percent even in three-phase short circuiting, compared to the no-load mode.

The switching apparatus in the generator circuit permits one to place the transformers under voltage from the 750-kV direction and to switch the power of the 6-kV sections BA-BD to the working leads immediately after completion of the pre-start check phase, bringing the reliability of the pre-start circuit of the unit up to the design level.

If bus lead of 24 kV is also connected to the generator by the time transformer T is connected to the voltage, the synchronization circuits can be checked at total voltage by connection of the KAG, which permits one to disregard the no-load of the generator-transformer unit during start-up tests, having reduced the rotational time of the turbogenerator during no-load revolutions.

If the elements of the excitation system, used in the test circuit (resistors and adjusting line) have not yet been installed by the time the power-generating unit has been connected to transformer voltage, it may happen that a voltage of 380 V can be delivered to direction BH of transformer T. However, the currents in the transformer circuits will be approximately less by a factor of 2 than in the main version, and a reliable check of the current circuits of the 750-kV direction may not be achieved due to the influence of noise. This difficulty does not arise at high voltage of 330 kV, since the current of the direction BH is higher.

Phase of start-up tests during no-load revolutions of turbounit. Main attention is devoted during realization of the described pre-start phase of tests in the test program on a rotating generator to testing the main circuit of the unit at rated current and the generator at rated voltage, removal of the no-load characteristic of the generator, and adjustment of the excitation system, which is not considered here.

The main feature of start-up tests of the generator with brushless excitation is the lack of possibility of taking the check characteristic of short circuiting, coincidence of which with the plant value usually permits one to judge the absence of turn shorts in the generator windings. This is determined by the fact that the current sensors of the rotor are installed during installation of the generator at the AES, and their characteristics are not known beforehand. Therefore, the reverse problem is solved in the short-circuiting mode: the rotor current sensors are calibrated on the basis of the plant characteristics of the generator short-circuiting and on the assumption of the absence of damage to the generator windings. A short-circuiting mode is created by installing a short on the 750-kV direction; therefore, the short-circuiting characteristics of the unit, found from those of the generator by multiplying the y axis of the latter by the ratio  $X_d/(X_d+X_T)$ , where  $X_T$  is the short-circuiting inductance of the transformer, reduced to the generator power. The accuracy of the characteristic found by this recalculation is very high, since the value of  $X_T$  comprises approximately 5 percent of  $X_d$ . Under these conditions, the error in calculation of the indicated ratio will be less by a factor of 15-20 than the inaccuracy of the values of  $X_d$  and  $X_T$ .

Analysis of the short-circuiting characteristics of four models of turbogenerators of type TVV-1000-4, found on the manufacturer's stand, showed their practical agreement. The rotor current, corresponding to the rated stator current, was in the range of 4.95-5.022 kA, i.e., this current can be assumed equal to 5 kA. The rated stator current in the short-circuiting mode of the unit with transformer group of type ORTs-417000/750, having rating plate short-circuiting voltage of 13.7 percent, will correspond to a rotor current of 5.25 kA.

The exciter was excited during the tests in the short-circuiting mode and in part of the phases of the no-load mode of the generator by using a standard thyristor converter, to which voltage was delivered by the adjusting line of 380 V, provided by the design, and powered from a separate transformer of 6/0.38 kV.

When the preparation program to the short-circuiting modes was compiled, one of the problems was to minimize the interference in the relay protection and control circuit, especially the protection lead by switching off the conductors. Only the circuits of the effect of the electric protection on turbine control, the circuits for delivery and disconnection of excitation from the control board and from the ASU of the turbounit, and some circuits in

the excitation circuit were open. Remote protection of the external short-circuits and the excitation losses, protection against overload of the rotor, the member of the third protection harmonic against shorts to ground of the ZZG-1 type and the arm of current transformer TA2 in the differential protection of buses and in the switch failure standby device were derived by standard straps and test units.

The correctness of connection and fulfillment of settings of the differential protection of the generator, transformer, unit and busing of 750 kV and protection of the reverse sequence of the generator was established during the pre-start phase of the tests. However, the unbalance in the reacting members of protection with first excitation of the generator to current equal to 5 percent of the rated value was measured for final confirmation of the correctness of correcting this protection. Not one of the differential protections to be checked at this current could respond falsely even in case of their erroneous connection to the total currents, since the most sensitive, differential protection of the generator has a setting of 15 percent of the rated current.

A check measurement of the unbalance voltages of differential protection of the unit, generator, transformer and 750-kV bus of the unit and also of the current protection of the generator of the reverse sequence was also carried out at rated stator current; the correctness of remote protection against loss of excitation and of external symmetrical short circuits is checked. Lack of determination of an error in installation is excluded provided that the pre-start check phase is fulfilled completely. Only the error in marking of the generator leads on both sides simultaneously may be undetermined. If this error is present, the generator will have reverse alternation of phases; therefore, correction of it on a rotating generator is compulsory. However, it is not worth measuring the residual voltage directly on the generator leads by opening the manways of the shields, as is recommended in [2]. Alteration of phases on residual voltage can be checked more quickly and more safely in the voltage transformer cell of 6-kV working lead, for example, in cell TV2, phased earlier with the 6-kV section. It is more convenient to measure the residual voltage in the generator voltage circuits or on the secondary winding of the rectifier transformer. Increased residual voltage (fixed in the range of 1.2-1.6 percent of the rated value) is typical for turbogenerators with brushless excitation, which is explained by leakage of some current in the rotor winding due to the effect of the residual voltage of the exciter.

The value and alternation of phases were measured during the first period of rotation of the turbounit at rated revolutions, parallel with tests of the turbine, which reduced the electric testing time.

Turbogenerators are usually tested by excitation of them to the standard voltage (130 percent of the rated value) in combination tests of high-power turbogenerators on

the plant stand. Therefore, despite the presence of a generator switch, which permits easy disconnection from the transformer, these tests were not duplicated at the AES, and the no-load characteristics of the generator were taken, beginning at voltage of 115 percent of the rated value according to [5]. To avoid unplanned fluctuations of excitation current for the time of taking the characteristic, a forbid was introduced in the switch of the connections, connected to the same 6-kV section as the transformer supplying the adjusting line.

The total voltages on the turbogenerator and exciter shafts was less than 1 V in both the mode with rated stator current and in the mode with rated voltage. This voltage was measured on one of the units at stator currents of 25, 50 and 100 percent of the rated value, and the shaft voltage comprised 0.16, 0.64, and 0.94 V, respectively.

The phase of tests in the loaded modes of the generator reduces mainly to testing the equipment under load, usually carried out by personnel of the electric power plant and by the personnel chief of the manufacturers with a check of the thermal and mechanical state for standard thermal and vibration check systems. The excitation systems are tested under load, the instruments that measure the turbogenerator power are checked, the member of the third protection harmonic of type ZZG-1 is adjusted, which is finally put into operation only after measurements of the working and decelerating voltages at generator power of 80-100 percent of the rated value.

#### Conclusions

1. A complex for pre-start tests of the generator-transformer block has been developed in power-generating units of AES with capacity of 1,000 MW.
2. The correctness of installation of power and monitoring circuits and of making the settings of relay protection devices was almost completely checked before start-up of the turbogenerator by methods that ensure confident conclusions of the readiness of the circuits and devices and that eliminate the need to duplicate the check on turns of the turbounit.
3. The characteristic feature of pre-start tests of a generator with brushless excitation is the impossibility of finding the check short-circuiting characteristic due to the absence of the characteristics of rotor current sensors. These characteristics can be found during pre-start tests on the basis of the plant short-circuiting characteristics of the generator.

#### Footnotes

1. The device was developed and manufactured by TsNIEL of Donbassenergo. The author of the development was A. P. Shapoval.

#### Bibliography

1. Vavin, V. N., "Releynaya zashchita blokov turbogenerator-transformator" [Relay Protection of Generator-Transformer Units], Moscow, Energoizdat, 1982.
2. "Metodicheskiye ukazaniya po provedeniyu kompleksnykh elektricheskikh ispytaniy blokov generator-transformator i ikh ustroystv releynoy zashchity i avtomatiki" [Methodical Instructions to Conduct Integrated Electric Tests of Generator-Transformer Units and of Their Protection and Automation Devices], Moscow, Soyuztekhnenergo, 1980.
3. Amkhinich, S. E. and Ye. V. Savchenko, "Pre-Start Integrated Check of Current and Voltage Circuits of Turbogenerator-Transformer Units," ELEKTRICHESKIYE STANTSII, No 10, 1975.
4. Zherve, G. K., "Promyshlennyye ispytaniya elektricheskikh mashin" [Industrial Tests of Electric Machines], Leningrad, Energoizdat, 1984.
5. "Normy ispytaniya elektrooborudovaniya" [Test Standards for Electrical Equipment], Moscow, Atomizdat, 1978.

COPYRIGHT: Energoatomizdat, "Elektricheskiye stantsii", 1988

UDC [621.311.25:621.039].016.4.003.13

#### On Pricing for Electric Power of AES

18610176d Moscow ELEKTRICHESKIYE STANTSII  
in Russian No 6, Oct 88 pp 89-91

[Article by B. E. Ratnikov, Candidate of Economic Sciences, L. D. Gitelman, Candidate of Economic Sciences, and A. S. Fiantsev, engineer, Urals Polytechnical Institute and VNII AES]

[Text] The comments published to our article [1-3] indicate that the problem of pricing for electric power is complicated and requires theoretical analysis for reasoning of one or another viewpoint. This circumstance forces us again to return to the problem so as to advance our position more definitely.

The concept of formulation of rates for the electric power of AES, advanced in [2], is mainly reflected in the traditional expenditure approach to pricing, which is not subject to valid criticism. The only function of price as an accounting function is essentially realized in this approach. Moreover, its stimulating and regulating functions acquire a special significance under conditions of introduction of economic methods of management of production. Thus, the suggestion of setting rates for electric power of AES on the basis of the mean sector net cost of production causes rejection. It is quite obvious that this method, which has become rather specific in other sectors of industry, will not stimulate the reduction



of current expenses of AES and will not stimulate an increase of production efficiency in nuclear power engineering, which requires expensive and skilled resources. The circumstance that there are presently no standards of expenditures can be considered an argument in favor of this principle. They must be worked out in any case.

The author of [2] feels that the rate for electric power is "one of the most important cost-accounting indicators." Hence the conclusion that the presence of some national economic parameters in the rate structure, specifically, of closing expenditures for the fossil fuel forced out by the AES, is impermissible. This in his opinion can be reflected unfavorably in the economic activity of enterprises. At the same time, it is noted in the conclusions of the article that "rates should reflect the level of national economic expenditures and should also take into account the cost-accounting requirements of Minatome-nergo." But this, generally correct postulation, contradicts the earlier advanced thesis of purely cost-accounting maintenance of the rate. This problem is the principle one in the theoretical aspect; therefore, let us consider it in more detail.

We feel that any price, and the rate for the electric power of AES is no exception here, should serve as that economic tool which would permit cost-accounting interests to be combined with interests of the national economy. If this principle were implemented in pricing, a basis would be found for solving the problem of agreement of cost-accounting and publicly needed final results. The existing prices for fuel and energy do not satisfy this condition; therefore, cost estimates of two types, which differ essentially by the methods of determination and economic maintenance, must be used in the technical and economic calculations in power engineering. Cost-accounting effectiveness is estimated according to prices, while national economic impact is evaluated according to the closing expenditures for fuel and energy. We do not support the viewpoints that prices and rates for energy should be necessarily established on the basis of closing expenditures, but they should take into account the national economic impact of the product, which as is known, corresponds entirely to the modern concept of pricing. This not only does not contradict the condition of operation of an enterprise in the self-financing mode, but on the contrary, contributes to creation of publicly needed prerequisites for organization of cost accounting.

If one adopts the hypothesis that national economic impact or the consumer effect of functioning of an AES should be reflected in the published rate, nuclear power engineering must be identified as a subsystem of the unified fuel and energy complex. Unfortunately, one must state that the systems approach to solution of the economic problems in power engineering are more frequently declared than actually used. If one follows this approach, then, all things being equal, the national economic impact of functioning of the same AES will be different in different regions (energy systems) as a function of the conditions of fuel supply and national economic

(regional) estimates of the fuel replaced by nuclear power. The national economic impact of an AES facility in one or another region, determined at the stage of planning technical and economic calculations, and the comparative national economic impact of existing AES in different regions are incorrectly identified. Let us emphasize that the regional ratios of these values rather than the directly absolute value of the national economic conservation of fuel are of interest to us in this postulation.

Based on the outlined theoretical references, we also proposed that the standard cost of generated power, standard profits and an additional rate that reflects the regional impact of nuclear power as an element of the fuel and energy complex be included in the rate for the electric power of AES. Understanding the complexity of a strict economic substantiation of the size of the additional rate, one can use the following method. All regions where AES are located are ranked according to the value of closing expenditures for fossil fuel, alternative to nuclear fuel. The rate in the basic region with minimal expenditures is established without a supplementary rate. The supplementary rate is determined in some regions as the difference between the national economic conservation of fuel in a given region and the basic value.

Operating expenses should be standardized according to groups of AES of the same type. The use of aggregated standards is permitted and there is no need to establish individual rates for each AES. Standard profit is calculated on the basis of the sector standard of profitability and of unit sector standards of the distribution of profits with regard to payment for resources, deduction for the budget and deduction for formulation of economic incentives funds. It is desirable to establish a single rate for all AES, operated within a given region (power system).

The author of [2] assumes that coordination of national economic estimates of the impact, achieved during design, with the rates of the AES should be provided by equality of the "coefficient of the impact of capital investments and of standard profitability to the funds taken into account in the rates." If one has in mind the rate of the comparative impact of capital investments, one may not agree with this, since it characterizes the increased impact, while profitability characterizes the absolute impact, and these indicators of effectiveness have a different economic content. The standard of profitability should be determined on the basis of sector need for profits according to given cost-accounting conditions. Another matter is that this indicator can be used as a standard of the absolute impact of capital investments when planning organizational and technical measures at existing AES.

Our proposed accounting for the effect of the functioning of nuclear power engineering in the rate is not abstractly theoretical, but realizes the stimulating and distribution function of price. We are talking about resource support and economic stimulation of the most important final result of the activity of AES personnel—reliability. It is

logical to assume that the relatively higher the impact—the bonus—the relatively greater national economic loss will occur due to a decrease of reliability and undergeneration of the power of AES. Penalty sanctions for each undergenerated kilowatt-hour of electric power in different regions where AES are located will increase (decrease) in proportion to this ratio; therefore, it is economically justified to direct additional funds to financing the organizational and technical measures for an increase of reliability in regions with relatively more expensive fuel balance. The traditional part of the rate (without the surcharge) is called upon to create normative-sector cost-accounting operating conditions of AES. Part of the profit received according to the surcharge to the rate is distributed between the fund for development of production, science and technology of the AES and a similar centralized fund of the ministry. This profit will not belong to recalculation to the budget. Centralization in the sector of financial resources, obtained through the surcharge, is necessary to fulfill the cost-accounting order of the AES for scientific research and experimental design developments in an increase of reliability. At the same time, individual directions can be worked out and implemented directly at the power plants. A combination of centralized and decentralized forms of management of reliability in nuclear power engineering is thus provided.

The rate for the electric power of AES, constructed according to the outlined principles, permits one to optimize the basis of concentration and distribution of limited financial resources on the basis of national economic feasibility, and also to activate economic incentives in management of the reliability at AES.

A problem concerning the organization of calculations for the electric power generated by the AES is important. The opinion is advanced in [2] that the electric power of an AES should be taken into account in the expenditures or energy systems, as is now done. Under the appropriate conditions, this can have a negative effect on the cost-accounting effectiveness of energy associations, which the author of the article himself generally recognizes [2]. However, he feels that this "creates prerequisites for objective competition of TES and AES" and further: "the comparative economy of TES and AES both during design and in the operating stage should predetermine their development." But, first, the comparative economic impact of existing TES and AES is determined along with the characteristics of planning solutions by improving the economic mechanisms (economic management systems), effective at enterprises of Minenergo and Minatomenergo. The question of restructuring of the management systems of TES or AES is validly raised in this regard, rather than the feasibility of the development of thermal or nuclear power engineering.

Second, "economic competition" of TES and AES begins to acquire a disparate character, since only the energy system will bear the losses even with a fixed rate, and even more so

with an increased rate for the electric power of AES. There is no feedback, i.e., the power system has no influence on the AES. Therefore, one should not talk about "objective competition of TES and AES."

If both the energy association and the AES are operating under cost-accounting conditions for the same network, the customer should pay for all the electric power generated in the region.

The development of nuclear power engineering, its economic impact and rate should not influence the mode of activity of the cost-accounting power system. The selling rate for the final customer should reflect all the publicly required expenditures for generation of electric power in a given region (the effective zone of the power system). The effective economic management of the process of electrification of a region can be organized on this basis. A relatively higher rate for the electric power of AES in regions with more expensive fuel in combination with an increased rate for a combination of power, which includes power plants operating on fossil fuel, contributes to activation of an energy-conserving policy in these regions and in making electric consumption more efficient. Accordingly, the development and functioning of nuclear power engineering must be regarded as constituent parts of a single process of electrification of the national economy.

Problems related to planning the rates of power systems, AES and selling rates for customers acquire great significance with regard to the use of rates as a tool of economic management of electrification. We feel that a review of rates should be carried out simultaneously with development of five-year plans. Changes in the structure of the generating capacities and rates of development of nuclear power engineering, the planned dynamics of the impact of power production should be reflected adequately in the rates. The rates will fully fulfill the stimulating and regulating functions inherent to them: on the one hand, they will contribute to an increase of production efficiency and, on the other hand, they will contribute to more efficient use of electric power by customers. Moreover, changes of rates do not at all have to be linked to overall reviews of prices. Moreover, a practice when, for example, the price for the product of energy consumer increases accordingly in parallel with an increase of the price for energy resources embodies an exclusively "expenditure" concept of pricing and has nothing in common with the economic methods of management of production efficiency.

Let us consider the proposals of the author of a comment to our article [3]. He feels it is feasible to distribute profits received from sales of all electric power in a

region between the power system in the AES in proportion to the fraction of the latter in the total operating capacity.

First, with this approach, the rate for the customer is fixed in a region and the profits subject to distribution is determined as a function of its level, i.e., the rate for the AES a priori is dependent on the rate established for the customer. It turns out that the rate for the electric power generated to customers in a region is not dependent on the structure of the generation of electric power and on the development of nuclear power engineering. Nevertheless, this rate does not reflect the publicly necessary expenditures for generation of power.

Second, the capacity of the AES changes (repair, introductions and so on); therefore, the rate for the power of the AES with this approach should change constantly.

Third, the proposed method of determining the profits of the AES does not correspond to the requirements of conversion of nuclear power engineering to full cost-accounting, since the profits obtained as a result of the calculations may deviate significantly from the standard cost, minimally required for organization of cost accounting.

Fourth, the author feels that the method which he proposed will stimulate an increase of the operating capacity of AES. But this is no longer implemented in an existing material incentives system in nuclear power engineering.

We feel that the main disadvantage of the proposed concept is that it did not take into account at all the specifics of generation in nuclear power engineering, its mutual relationship in the fuel and energy complex, and its influence on the process of electrification. With this approach, the AES is essentially identical to any electric power plant operating under cost-accounting conditions.

### Bibliography

1. Ratnikov, B. Ye., L. D. Gitelman, Yu. N. Artemov, and V. S. Fiantsev, "Principles of Formulation of Rates for the Electric Power of AES," ELEKTRICHESKIYE STANTSII, No 2, 1988.
2. Denisov, V. I., "On Methods of Calculating the Rate for Electric Power, Generated by Nuclear Power Plants," ELEKTRICHESKIYE STANTSII, No 2, 1988.
3. Solovyev, B. Kh., "On the Principles of Formulation of Tariffs for the Electric Power of AES," ELEKTRICHESKIYE STANTSII, No 2, 1988.

COPYRIGHT: Energoatomizdat, "Elektricheskiye stantsii", 1988

UDC 621.039.5

### Holding and Transfer Pond for Nuclear Fuel

18610339 Moscow OTKRYTIYA

IZOBRETENIYA in Russian No 41, Nov 88 p 254

[Article by Yu. P. Kaloshin, S. L. Belokhin, M. L. Klinotskiy, Yu. F. Yefremov, Ye. M. Vald, and V. V. Bibanov, Heat Engineering Structures Design All-Union Scientific Research and Design Institute]

[Text] The pond for holding and transferring nuclear fuel under a layer of fluid, which is to be used primarily at nuclear power plants, includes a lining for its reinforced concrete walls and its bottom. This lining is distinguished by the fact that, in order to increase the reliability of detecting leakage sites and eliminating them, the surface of the reinforced concrete walls and pond bottom under the lining has been covered by leak-tight insulation in such a way that a leak-tight chamber is formed between the lining and insulation layer. Drainage material is placed between the bottom lining and the insulation. The lining is equipped with a branch pipe that has a locking device to feed inert gas into the leak-tight cavity and with a branch pipe to discharge any leakages.

COPYRIGHT: VINIPI, 1988

UDC 620.9

### Study of Light Transmission Coefficient of Certain Materials Used in Solar Technology

18610180 Tbilisi SOOBSHCHENIYA AKADEMII  
NAUK GRUZINSKOY SSR in Russian Vol 131 No 1,  
Jul 88 pp 109-112

[Article by M. V. Kacharava, Georgian Subtropical Agricultural Institute, Sukhumi; paper presented by Academician V. I. Gomelauri on 10 Feb 1988]

[Text] The efficiency of solar power-generating units is largely determined by the optical characteristics of the materials used in their coolant circulation systems, which is where the solar energy enters the working medium through a transparent material.

We have developed a method of measuring the light transfer coefficient by using an electrooptical principle. It is common knowledge that the phase difference depends on the voltage acting on the crystal and that it is directly proportional to the electrooptical coefficient.

Industry produces crystals in which the index of refraction between ordinary and unusual beams changes when an electrical field is applied.<sup>1</sup> If a polarized monochromatic light is passed through such a crystal, a phase difference between ordinary and unusual beams becomes apparent, and these beams interfere after exiting the crystal. An analysis of the pattern obtained after the light has passed through the crystal reveals that the light is elliptical polarized light with linear and circular polarization as its boundary values. Depending on the magnitude of the phase difference, any of these elliptical polarization values may be obtained. In turn, the magnitude of the phase difference depends on the electrical field applied to the crystal:

$$(1) \delta = [r n u] / \lambda,$$

where  $\lambda$  is the wavelength,  $u$  is the voltage applied to the crystal,  $r$  is the electrooptical coefficient, and  $n$  is the index of refraction.

If an analyzer is placed after a crystal with an electrooptical effect, then when the value of the phase difference is such that the light is linearly polarized, the magnitude of the light flux after the analyzer is equal to zero. On the other hand, at phase difference values where the light is circularly polarized, the light flux after the analyzer will be maximal. In other cases, the intensity of the light flux will vary sinusoidally between these two values. Thus, the system described is a modulator for monochromatic radiation. We will imagine that ordinary polarized light has passed through such a system. Then, for different fixed phase difference values (which is made identical to the respective voltage of the electrical field), we will have a maximum light intensity after the analyzer for one color and a minimum intensity for the other. In the case

of a smooth change in the voltage applied to the crystal through the analyzer, we will see a change in the color throughout the entire visible scale.

Unfortunately, the bandwidth of this system is rather large, and it cannot be separated from the spectrum's narrow band. Several crystals that had different lengths and that were arranged in a series were used to accomplish this. Besides equation (1), the following relationship may also be used to determine the phase difference:

$$(2) \delta = [2\pi \times n \times l] / \lambda,$$

where  $n$  is the index of refraction;  $l$  is the length of the crystal; and  $\lambda$  is the wavelength of the light flux.

From this dependence, it may be noted that as the crystal's length increases, twofold, for example, the difference in the flux's behavior remains constant, and the difference between the maximum and minimum values of the light flux are cut in half.<sup>2</sup>

A DZ-28 microcomputer was introduced to automate and simplify the process of measuring the light transmission coefficient. Signal-generating instructions were placed in the computer's memory. An interface converts these signals into electrical current that is amplified by an amplifier, after which they are fed to the crystals to control them. The values of the intensity of the beam passing through the system are registered by a photomultiplier tube. These values from the photomultiplier tube are stored in the computer's memory. A program that has been entered in the computer is used to determine the energy as a function of the wavelength for the light source.

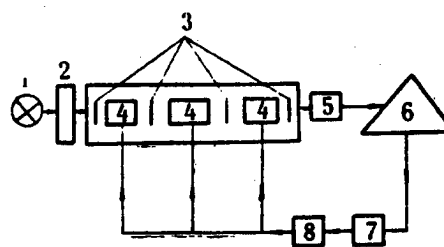

Figure 1. Block Diagram of the Unit

Key: 1. Light source 2. Specimen 3. Polarizers 4. Crystals 5. Photomultiplier tube 6. Computer 7. Interface 8. Amplifier

To determine the light transmission coefficient, the object under investigation is placed between the light source and the crystals, and the measurement is made in an analogous manner. A computer automatically performs the operation of dividing the signals obtained by the respective signals that were determined and stored in the computer's memory when the light source's spectrum was analyzed. The results obtained for the light transmission coefficient may be output on a digital printer or

simultaneously output onto a digital computer panel. Figure 1 presents a block diagram of the device used to determine the light transmission coefficient.

To check the method used to measure the light transmission, we determined the light transmission coefficients of several sample colored glasses that had been manufactured in accordance with the All-Union State Standard.<sup>3</sup>

The measurement results indicate that the measurement method and research unit that we developed make it possible to measure light transmission coefficients with an error not exceeding plus or minus 2 percent.

We conducted experiments in the light transmission of type Dakril-2M polymethylmethacrylate on the research unit.

It is common knowledge that polymethylmethacrylate is used extensively in solar technology. In view of this, a great deal of attention has been focused on studying its optical properties—particularly because industry manufactures different grades of this material with different thicknesses and colors.<sup>4</sup> It is thus necessary to study the optical properties of these materials. It is commonly known that the light transmission coefficient of materials is generally tied to their thicknesses and to their light absorption coefficients:

$$\tau = (1 - \rho)^2 e^{-kd}$$

where  $\tau$  is the material's light transmission coefficient,  $\rho$  is its reflectivity,  $k$  is its light absorption coefficient, and  $d$  is its thickness.

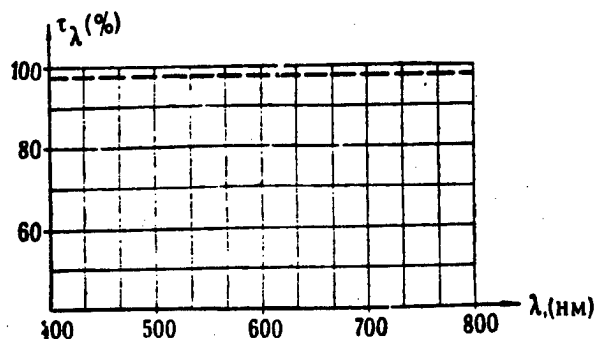

Figure 2. Light Transmission Coefficient as a Function of the Radiation Wavelength for Polymethylmethacrylate. (The x axis represents the wavelength [in nanometers].)

Experiments were conducted on a specimen 5.5 mm thick at room temperature. Figure 2 presents the results of the experiments.

As is evident from Figure 2, in the visible region the light transmission spectra of polymethylmethacrylate are of the nature of a decrease as the radiation's wavelength

increases. The experiments were conducted in the 400- to 800-nm radiation wavelength range. The measurement results correspond to the data in the literature.<sup>3,4</sup>

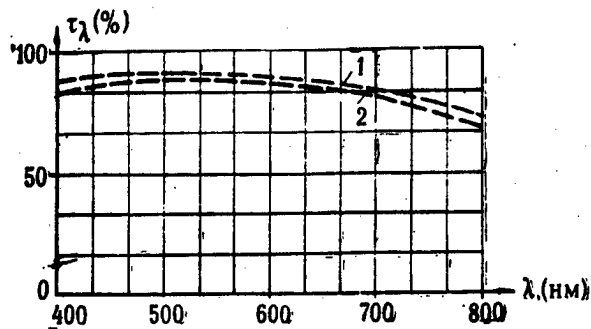

Figure 3. Light Transmission Coefficient as a Function of the Radiation Wavelength for Window Glass. (The x axis represents the wavelength [in nanometers].)

As is common knowledge, so-called vertically drawn window sheet glasses (the Gusev Plant imeni Dzerzhinskiy) have been used extensively in solar technology. The value of the light transmission coefficients of these glasses has aroused a great deal of interest since the heat transfer agent receives the entire radiant flux when it passes through the layers of heat.

In view of this fact, we measured the light transmission coefficients of the specified glasses. We selected glasses 2.5 and 5.5 mm thick. Figure 3 presents the results of the experiments. These results demonstrate that transmission depends (in a complicated manner) on the radiation's wavelength and that the highest transmission is found in the region around the green spectrum. The data that we obtained with respect to window sheet glass are in good agreement with the literature sources.<sup>5</sup>

#### Bibliography

1. USSR Author's Certificate No 1205651, 01, 3/26.
2. Pol, R. V., "Optika i atomnaya fizika" [Optics and Nuclear Physics], Moscow, 1966.
3. "Steklo opticheskoye (TU) GOST 9411-81" [Optical Glass (Specifications) All-Union State Standard 9411-81], Izd-vo standartov, 1981.
4. Gudimov, M. M., and Perov, B. V., "Organicheskoye steklo" [Organic Glass], Moscow, 1981.
5. "Steklo opticheskoye bestsvetnoye—fiziko-khimi-cheskiye kharakteristiki, GOST 13659-78" [Colorless Optical Glass—Physicochemical Characteristics, GOST 13659-78], Moscow.

UDC 621.315.66

**Use of Reinforced Concrete Supports on 6-10 kV Power Transmission Lines in Western Siberia**  
18610161A Moscow VESTNIK MASHINOSTROYENIYA  
in Russian No 10, Oct 88 pp 13-14

[Article by Ye. I. Teterev, engineer]

[Abstract] Reinforced concrete supports for use on 6-10 kV power transmission lines in Western Siberia must meet special requirements due to the severe weather of the area. This article illustrates the types of supports used and briefly describes construction techniques to be used when erecting them.

UDC 627.81

**Protecting Territories From Flooding During Construction of Reservoirs**  
18610161B Moscow VESTNIK MASHINOSTROYENIYA  
in Russian No 10, Oct 88 pp 52-54

[Article by E. G. Kotenkova and N. V. Zub, engineers]

[Abstract] Flooding and insufficient ground water depth of territories near reservoirs created for irrigation or power generation is a problem which has attracted recent attention. Engineering steps can be taken to prevent ground water rise near reservoirs. Complete studies are required for this purpose to determine all possible causes and the degree of their influence on ground water rise in the area around a reservoir. Infiltration from surface run-off accumulated in construction trenches and leakage from underground water lines are significant causes of ground water rise. Existing large sources of infiltration and leakage must be considered in development of reservoir designs. Steps must be taken to prevent leaks and unnecessary discharge and to support efficient water use when reservoirs are constructed. Figures 2.

UDC 621.18.002.72:69.057.3

**New Technology for Installation of TGME-206 Boiler Units**  
18610161C Moscow VESTNIK MASHINOSTROYENIYA  
in Russian No 10, Oct 88 pp 65-67

[Article by V. S. Smirnov and K. V. Kuznetsov, engineers]

[Abstract] A fourth 200 MW power unit was installed at the Pechora Regional Electric Power Plant in the second quarter of 1987, consisting of a type TGME-206 boiler, K-200-130-3 turbine and TGV-200-2 generator. This article describes the process of installing the boiler unit, involving the design and manufacture of special supports and dual-beam 50-ton traverses. Diagrams illustrate the arrangement used to hoist and move the units. Installation of the boiler unit took a total of two months by a

team of 24 men. The new installation technology allowed the construction of a smaller building, saving 28,000 rubles in heating cost per year. Figures 3.

UDC 621.181.7

**Means for Improving Combustion of Low-Grade Anthracite Fines at Electric Power Plants**  
18610133A Moscow TEPLOENERGETIKA in Russian  
No 9, Sep 8 pp 2-10

[Article by Yu. L. Marshak, doctor of technical sciences, Yu. P. Artemev, engineer, S. N. Mironov and K. Ya. Polferov, candidates of technical sciences, All-Union Institute of Heat Engineering]

[Abstract] The presently observed and projected future decreases in the quality of anthracite fines create combustion problems. Radical solutions to the problems might include the construction of beneficiation plants or new mines in the Donets basin, the creation of new boilers designed for combustion of low-grade anthracite fines, or the redesign of existing boilers used with 200 and 300 MW power units. Suggested modifications to existing units, including preparation and trying systems as well as combustion systems, are described. Implementation of the recommendations contained in this article would allow combustion of fines with  $Q=16.8$  MJ/kg in 200 and 300 MW power unit boilers without fuel oil or gas. A mean flame temperature in the active combustion zone of 1650-1700°C can be achieved, which should be sufficient to assure reliable slag elimination, in spite of the reduced specific heat of combustion. Moderate oxygen enrichment of combustion is another possibility requiring further investigation. Figures 5, references 17: Russian.

UDC 621.181.002.52

**New Battery Cyclone to Trap Hard and Brown Coal Dust**  
18610133B Moscow TEPLOENERGETIKA in Russian  
No 9, Sep 88 pp 14-18

[Article by V. A. Reznik, P. M. Luzin and N. N. Prokofichev, engineers, Scientific-Production Association of Central Institute of Boilers and Turbines]

[Abstract] A battery-type dust trap consisting of 13 large cyclone elements with 512 mm cylinder diameter has been developed to trap the dust of brown coal. The hydraulic resistance of the BPR-512 dust trap is 1.55 kPa under the operating conditions of the unit. Units with 13, 31, 48 and 62 elements have been designed, with capacities of 40,000-200,000 m<sup>3</sup>/hr. The two-stage dust-trapping units remove up to 99 percent of the dust from the air and meet the requirements of explosion safety,

reliability and maintenance of good operating characteristics over long-term operation. The unit is now ready for field operational testing. Figures 3, references 4: Russian.

UDC 628.517.2

**Method of Decreasing Effect of Power Plant Noise on Urban Residential Areas**

18610133C Moscow *TEPLOENERGETIKA* in Russian No 9, Sep 88 pp 26-29

[Article by A. F. Dyakov, N. I. Serebryanikov, V. P. Gusev, candidates of technical sciences, E. P. Volkov, L. A. Rikhter and G. L. Osipov, doctors of technical sciences, USSR Ministry of Power Engineering; Power Engineering Institute imeni G. N. Krzhizhanovskiy; Moscow Institute of Power Engineering; Scientific Research Institute of Construction Physics; Moscow Rayon Power Administration]

[Abstract] The installation of 250-300 MW supercritical steam power units and other modern power equipment has created the problem of harmful noise effects from power plants in residential areas of cities. This article

studies the problem of noise pollution of surrounding residential areas, which is particularly important in the USSR, where large heat and electric power plants are constructed within city areas and designed for maximum fuel and power resource economy. In 1986, the USSR State Construction Commission and USSR Ministry of Power Engineering created an inter-industry scientific and technical team for the development and introduction of sound control measures at the power plants of Moscow. Studies have shown that the equipment contained within power plant buildings does not produce harmful noise pollution outside the buildings, except for occasional brief releases of steam through safety valves, for which sound damping equipment has been developed. Transformers, cooling towers and other equipment outside buildings may cause harmful noise pollution, but produce noise at little height, so that the noise is blocked by surrounding obstacles. New, high-capacity gas handling equipment produces far greater noise pollution, which is not greatly reduced by surrounding structures. The noise level at the top of a tall smokestack may be quite high. Noise pollution must be considered along with other types of pollution created by power plants in urban planning. Figures 4, references 3: Russian.

UDC 621.9.04:658.512.624;621.9.06-529.004.14

**Group Machining Components on Numerical Program Control Machine Tools**

*18610344a Moscow MASHINOSTROITEL in Russian No 10, Oct 88 pp 23-24*

[Article by G. F. Volodchenko, candidate of technical sciences, L. I. Kononenko, engineer, and V. I. Velitskiy, graduate student]

[Text] Introducing the group machining of components on machine tools with numerical program control is one of the most important directions in reducing the cycle required for the technological preparation of production and the manufacture of components under conditions of small-series production. The presence of correcting devices in numerical program control machine tools makes it possible to machine the same types of components in accordance with a single control program. Components are grouped according to the size of the diameter and length correction allowable on numerical program control machine tools.

An analysis of the component family, particularly the design types and type sizes of body-of-revolution-type products, that is manufactured by heavy machine tool building enterprises confirmed the feasibility of using group machining on machine tools with numerical program control. Seven size groups (Table 1) were formed as a result of an analysis of the designs of axis- and finger-type components. These groups included 345 type sizes. Each size group encompassed components with a small size spread (Table 2 lists the components included in the fourth size group). When control programs are developed for machine tools with numerical program control, the coordinates of the points at which the cutting tool is located are calculated on the basis of the average diameter and length of the components included in the group. In order to machine all of the components in the group, corrections relative to the X and Z axes that make an allowance for the specific dimensions of the components being machined are entered into the control program. The coordinates of the points at which the tool is located, allowing for the correction, are written into the process design chart. A computer is used to automate the grouping of the components in accordance with the classification code.

**Table 1**

Group No.	Component Dimensions, mm		No. Components Per Group	Average Size, mm	
	Diameter	Length		Diameter	Length
1	6-16	15-30	32	10	22
2	8-18	40-55	48	10	48
3	8-16	60-78	68	10	70
4	20-30	50-68	59	20	60
5	20-30	90-102	45	30	100
6	25-35	70-87	55	30	80
7	25-35	112-130	38	30	112

**Table 2**

Sketch No.	Product Designator	Component Dimensions, mm		No. Components, units
		Diameter	Length	
21141	KZh1852	20	50	9
6714	IA832	20	52	16
7621	IA832	20	55	20
6814	IA832	20	60	8
2151	P187S19	30	54	6
1442	KZh1840	20	68	4
4079	IA660	30	54	16
Total				59

Thus, introducing group machining on machine tools with numerical program control makes it possible to increase the equipment's load factor to between 75 and 80 percent and to reduce the labor intensity of developing control programs by 40 percent on average.

COPYRIGHT: Izdatelstvo "Mashinostroyeniye", Mashinostroitel, 1988

UDC 621.833.15

**External Gear Train**

*18610344a Moscow MASHINOSTROITEL in Russian No 10, Oct 88 pp 23-24*

[Article by M. A. Voronchikhin, candidate of technical sciences]

[Text] Two racks are used to form the profiles of the teeth of the proposed gear (author's certificate 844858) on the drive and driven pinions (gears).

Figure 1a depicts a cutting tooth (1) with an evolvent profile that is involved in the formation of the line made to cut the drive wheel. Figure 1b illustrates cutter (2), which has an evolvent profile (a gear cutter may be used) and which is involved in forming the rack to cut the driven wheel. Figure 1c presents the frontal cross section of the teeth of a straight-toothed gear whose drive wheel (3) has teeth with a convex profile and whose driven wheel has teeth with a concave profile. The profile of the drive wheel's teeth is formed by the envelope of the concave side of the arc of the evolvent of the rack circle that is cut by the cutter (tooth) (1). The concave profile of the driven wheel's tooth is formed by the envelope of the convex side of the same arc of the evolvent of the rack circle cut by the cutter (2).

When the contact stresses, the slide of the tooth profiles, and the flexural strength of the teeth of an evolvent gearing whose teeth have profiles that were formed by



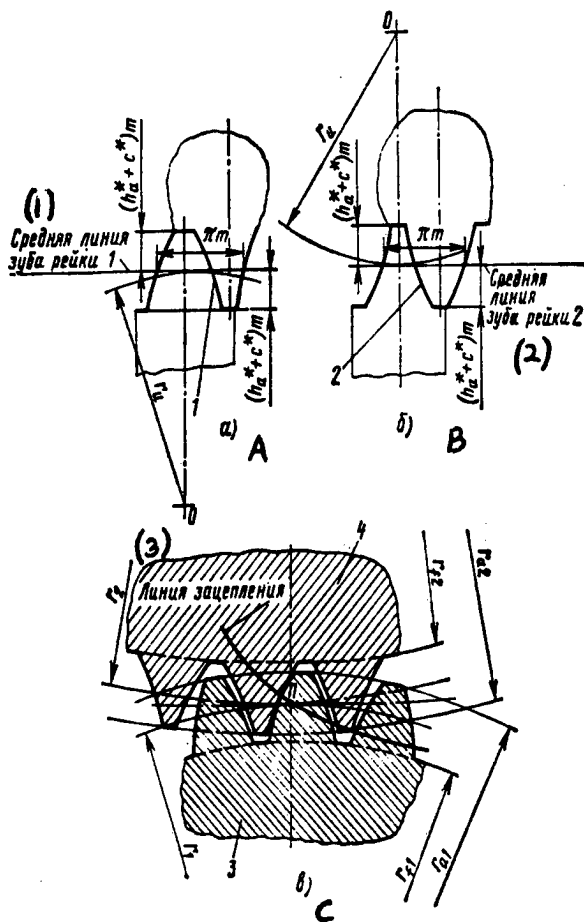

Figure 1.

Key: 1. Center line of the tooth of rack 1 2. Center line of the tooth of rack 2 3. Line of action

using an initial contour that is in accordance with GOST 9587-81 are compared with those of the proposed gear, it is evident that the latter type of gearing is better. The engagement in the proposed gearing is smoother from a design standpoint thanks to the fact that the contact strength does not depend on the flexural strength. This makes it possible to create rational full-strength designs. Especially high engagement qualities are achieved in the proposed gearing by making a correlating adjustment in the engagement that combines the angle correlation of the cutting tool (shears) and the height correction of the gearing's teeth. In this case it is advisable to increase the angle of the axial profile  $\alpha_0$  of the tooth of the initial tool rack required to shape the cutting teeth intended for cutting the gear racks or the hobs to between 22 and 25 degrees. The angle and height corrections of the proposed gearing are most effective in the engagement of gears with helical bevel teeth. Ultimately, this type of corrective adjustment of a helical bevel-toothed gearing makes it possible to obtain a tooth (head) with a convex profile on the drive wheel and a cutting tooth with a concave profile on the driven wheel. This makes it

possible to increase the flexural strength and rigidity of the teeth and to approach a Novikov tooth system from the standpoint of contact stresses. The initial profile, which is shown in Figure 1a, may also be used for worm gears (author's certificate 714077).

The gearing may be used in mechanisms in which the teeth are required to have an increased load-carrying capacity and wear resistance and where the teeth are not very sensitive to skewness and have a high flexural strength.

COPYRIGHT: Izdatelstvo "Mashinostroyeniye", Mashinostroitel, 1988

UDC 658.52.011.56.012.3.004.14.621.9

### Machining FMS—Integral Part of Modern Production Plans

18610343a Moscow MASHINOSTROITEL  
in Russian No 11, Nov 88 pp 12-15

[Article by V. I. Zagurskiy, candidate of technical sciences]

[Text] The technological updating of production is closely tied to restructuring the very foundations of machining technology and robotizing it. Together with the problem of creating new industrial robots, the problem of designing "robotomorphous" production and production processes is becoming increasingly urgent. In other words, a systems approach to design that encompasses technology, equipment, and production organization and management is needed.

Flexible manufacturing systems [FMS] provide appreciable advantages in machining production when compared with traditional equipment. They make it possible to achieve the following: a 50 to 75 percent reduction in the number of production equipment units, a maximum 80 percent reduction in the number of service personnel, a 25 percent reduction in the specific per-component expenditures on workers' wages, a 55 percent reduction in production expenditures, a 60 percent reduction in production areas, an 87 percent reduction in overhead and expenditures on ancillary operations, a 50 to 70 percent reduction in machining time, a 90 percent reduction in adjustment time, and a five- to sixfold reduction in the time required for the total production cycle (from the order to the output of the finished product).

FMS have been divided into systems for machining components belonging to the classes bodies of revolution, casing components, and plane and prismatic components. Combination-type systems also exist. Type ASV (i.e., automated shaft-machining systems) FMS, which include 10 machine tools with numerical program control [NC], are capable of manufacturing 55,000 to 60,000 relatively hard-to-manufacture, body-of-revolution-type components per year while operating on a two-shift basis. The machine tools' average utilization factor from the standpoint of machine time ranges from

0.55 to 0.6. From the standpoint of per-piece calculation, it averages 0.8 to 0.85, which is 1.5- to 1.8-fold higher than the coefficient for the existing practice of operating individually used machine tools with one and the same productivity. The specified type of FMS, which must be serviced by 24 persons (including 10 machine tool operators) have a yearly economic impact of about 120,000 rubles.

Type ASV sections may be used in plans to update existing production. They are recommended for use in the small-series production of components belonging to the class of bodies of revolution manufactured from cast and forged blanks or from rolled stock. Plane components (planks, levers, brackets) and small casings can also be machined on drilling and milling machine tools in a section. A section can also include tooth-machining and grinding modules and other NC equipment, with lathing semiautomatons of one model or another constituting the principal equipment. Depending on the specific models and number of machine tools built in, a section may range from 35 to 60 m long with an overall width of 14 m.

The extent to which the machine tool modules and universal and other machine tools used in an FMS are equipped with auxiliary devices that expand their production capabilities and that provide the maximum degree of comprehensiveness in machining components is especially important.

Most models of currently produced universal machine tools and flexible production modules (with a small exception) have no functional redundancy, which makes it difficult to optimally concentrate the production transfers occurring at machine tool positions. What is even more important, this does not permit (within the framework of FMS) the programming of such processes as face turning or using large-diameter cutters to trim allowances in a single pass, taper boring, broaching and thread broaching, machining the complex contour of shaped surfaces, turning parallels and grooves, recessing grooves, drilling deep small-diameter holes, thread cutting, and grinding plane and other surfaces of casing components, which are frequently encountered during the integrated machining of components. The design problems entailed in equipping universal machine tools and module-centers with multispindle drilling and threading heads that can be changed quickly and automatically (without which high-productivity machining of smooth and threaded holes cannot be achieved) are far from solved. The measurement capabilities of the automatic operating cycle of most metal-cutting machine tools are constraining factors.

Selecting the ideal production equipment makes it possible to successfully accomplish most tasks arising during the creation of FMS with high technical characteristics. We will present only one example.

In the 12th Five-Year-Plan, the Odessa Precision Machine Tool Plant imeni the 25th CPSU Congress will manufacture type ASK-0 (automated system for machining casing components) flexible production installations. They will consist of universal machine tools for machining 400 x 400 x 400-mm casing components from cast iron, steel, and nonferrous metals.

The flexible production installations will include from two to 10 universal high-precision drilling-milling-boring machine tools with automatic tool and workpiece replacement. They will have a horizontal (model 2204VM1F4) or vertical (model 2254VM1F4) configuration or especially high precision flexible production modules with adaptive control and active monitoring (model OP2G04AMF4M). Besides the principal production equipment, the flexible production installation will include the following: up to 4 vertical magazines for storing blanks and workpieces, a transport system 50 m long for the rail carriage transfer satellite attachments with components between machine tools and component magazines, from 3 to 14 manipulators (hydromechanical and with parallel arranged positions) for loading components into machine tools and magazines and for unloading them, from 12 to 72 satellites for mounting components; a central section control system based on an Elektronika-60 microcomputer, and cutting and auxiliary tools (no less than 2 sets).

A computer is used in the flexible production installation to directly control the machine tools and transport-warehousing system, for accounting, for operations scheduling, and for dispatcher control of the section's operation. Thus, the central computer not only controls all of the nodes and mechanisms in the section but it also coordinates the material and information streams.

The selection of the production equipment used in the FMS is critical, and the initial and finishing operations play an extensive role. The following section of text describes a number of new models of equipment for performing these operations.

The Yeysk Machine Tool Plant manufactures single-machine tool robotized complexes based on a model YeM500-5 centering and turning miller (maximum workpiece diameter, 100 mm; maximum workpiece length, 1,000 mm) as well as on special NC lathing semiautomatons. The latter permit the integrated machining of body-of-revolution-type components in a single stop thanks to the implementation of complex automatic cycles using a set of such tools as straight-turning, facing, grooving, chamfering, threading, and other cutting tools that are located in a rotary cutting head. In general, these machine tools are intended for machining components in centers, but when outfitted accordingly, they can also perform chuck operations.

The use of two-spindle lathe group machine tools in robotized complexes is also very interesting. The independent loading of each of the spindles provides for

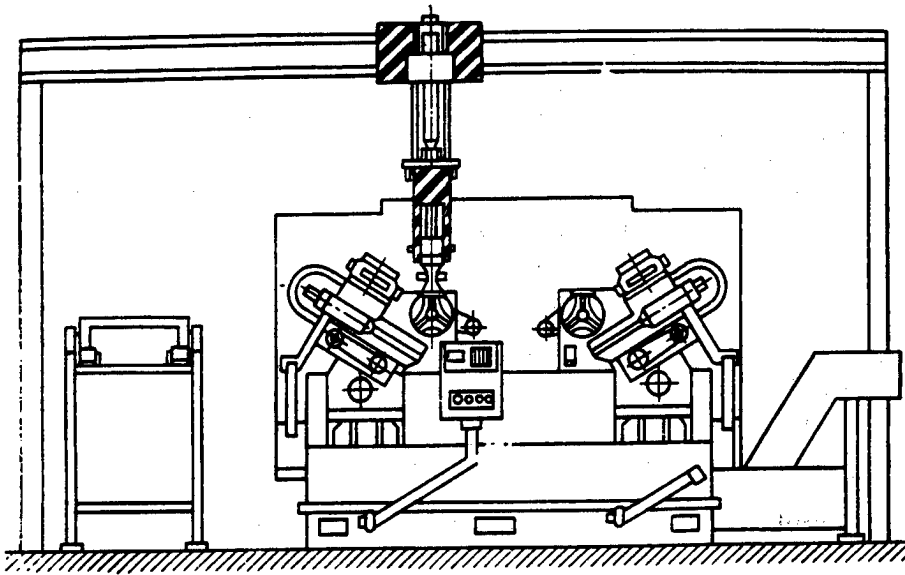

Figure 1.

three versions of operations on the machine tool: the machining of two identical components from one side, the machining of one component from two sides, and the machining of two different components from one side. The model RM315 two-spindle modular machine tool (largest machining diameter, 500 mm; workpiece height, within the bounds of 200 mm) that is manufactured by the Moscow production association Machine Tool Plant imeni S. Ordzhonikidze can be included in an MRK 40.202 single-machine tool lathe complex (Figure 1). The robotized complex is serviced by an M40P portal robot (Metal-Cutting Machine Tools Experimental Scientific Research Institute), which makes it possible, based on sleeve-, disk-, and flange-type components, to machine cylindrical, conical, spherical, and outer and inner threaded surfaces and to cut straight and sloping grooves with a recess. Fastening the cutting tools in four-sided revolver heads with precise automatic locking permits simultaneous machining by several machine tools.

From the standpoint of technological capabilities, this type of robotized complex can surpass an automated line consisting of two single-spindle lathes, and when necessary, two MRK 40.202 complexes can be used as the basis for configuring a short automated line in which a portal-type industrial robot equipped with a UPM-331 three-coordinate NC device is used for the frontal servicing of four spindle positions for machining a complex component.

By 1990, the country's production of lathe group flexible production modules will constitute more than half of the entire amount of machine tool modules manufactured. Of those flexible production modules coming from machine tool builders during the 12th Five-Year-Plan, those that will be used most are the 1P420PF30 and 1P420PF40 modules

produced by the Berdichev Machine Tool Plant Komsomol'skiy, the 1P756DF3RM module produced by the Ryazan Machine Tool Production Association, and a number of others. The improved model 17A20PF30RM machine tool is being launched into production at the Moscow Machine Tool Production Association Krasnyy Proletariy. The manufacture of lathe flexible production modules for large-series production is beginning (at the Moscow Production Association Machine Tool Plant imeni S. Ordzhonikidze and at the Baranovichi Automated Line Plant, these flexible production modules are being manufactured on the basis of frontally configured NC two-spindle semiautomatons). The Krasnodar Automated Lines Special Design Office is developing a design for lathe flexible production modules with a central drive for the high-productivity simultaneous machining of long components from two sides.

The technological capabilities of other flexible production modules that are being designed are also being expanded. Some of them will include devices for heat treating, grinding, trimming flash (including some using lasers), performing simple assembly operations, washing, drying, inspecting the physicomachanical properties of blanks, and marking.

The finishing processes entailed in manufacturing shafts and other components having the form of bodies of revolution frequently involve grinding and threading. Robotized complexes are currently being used primarily for turning since the respective component base (NC lathes, wide-range clamping chucks, comparatively simple industrial robots, machine tool equipment) have already been developed. There is, however, a great need to robotize the subsequent machining of components that have completed the turning stage, especially in view of the prospects of combining robotized complexes into FMS.

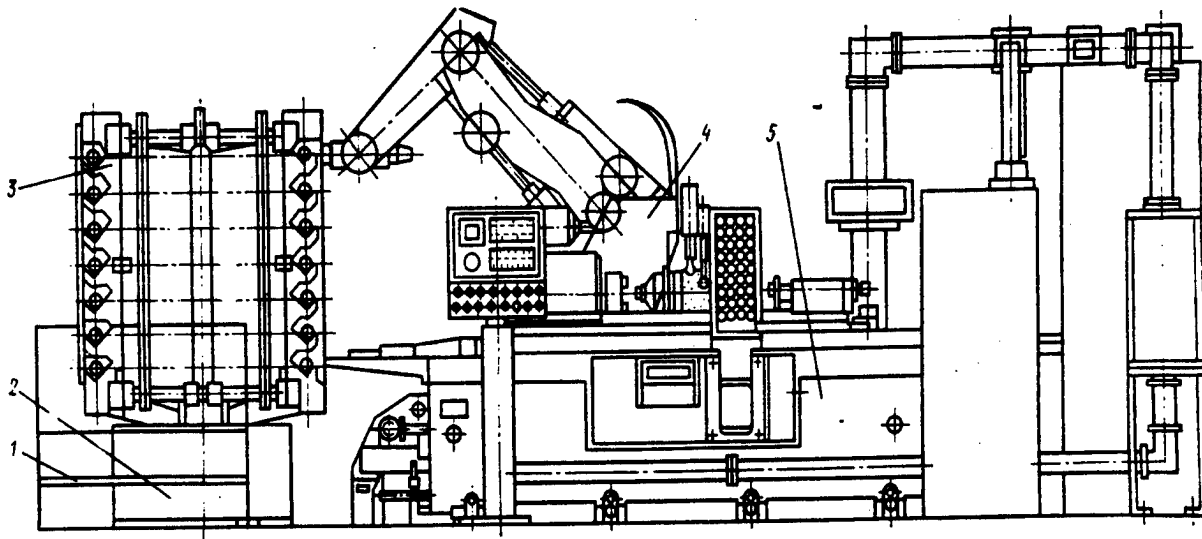

Figure 2.

The Kharkov Machine Tool Production Association was the first to begin manufacturing two modules for grinding group robotized complexes—the KhShK-001 and the KhShM-003 grinding modules (the KhShM-002 and KhShM-005 modules are also being launched into production). They were developed in consideration of a painstaking analysis of the components to be machined on them from the standpoint of the most modern grinding technology, thereby solving the problems entailed in increasing the required industrial robots, gripping devices for them, wide-range driver device to the machine tool's spindle, etc.

The KhShK-001 module includes a model 3K151VF20 NC cylindrical grinder (5) (Figure 2), a model KhShR-001 specially configured industrial robot (4), a magazine (2), a pallet set (3), and an enclosure (1). Different versions of incorporating the module into the section's plan are possible in view of the fact that the industrial robot's manipulator is capable of making a programmed turn of up to 270° around the vertical axis. A floor-model-type robot located behind the machine tool can, for example, take the workpiece from an adjacent module, load it into the machine tool for the grinding operations, and then unload it into the magazine. In all cases the module is configured with an allowance for the safety of service personnel, the convenience of tie-ins with the in-shop transport, and convenient access to equipment, and it makes economical use of the production area.

The industrial robot's gripping device reliably holds components with different shapes and masses (within the limits of the robot's payload) both during manipulation and when the electric power source has been disconnected. It has two orienting degrees of freedom. Therefore, turning the gripping device 90° around the horizontal axis and 180° around its own axis makes it

possible to grind the neck of components from one and then from the other side. The trajectory of the industrial robot's manipulator is programmed in accordance with the shape and dimensions of the component and the sequence in which it is machined, as specified by the machine tool's NC device. The presence of different-diameter end necks on the workpieces is not an obstacle for the robot's gripper, nor is it an obstacle in configuring the components on the machine tool thanks to the wide-range driver chuck that can turn a component held on cylindrical or slotted surfaces or by key slots. Each neck may be ground in its own machining modes, which boosts the grinding process and reduces the amount of time required for it. The cylindrical and conical surfaces of a shaft may be ground after programming the feed scheme selected.

Facial surfaces are machined by the polishing method. However, unlike in the case of the machining of a cylinder or cone, the machine tool guides the circle with some recessing along the face. This may be done separately on a specialized stand. It is thus possible to grind all of a component's cylindrical, face, and conical outer surfaces in one of the module's (machine tool's) work cycles. In conjunction with the cycle's other distinctive features, the module expands the technological possibilities of implementing all types of cylindrical grinding within the confines of an FMS. Practice has shown that, with the help of a robotized complex or KhShK-001 module, machining on a model 3K151VF2 machine tool is much more productive than machining done by using a free-standing machine tool with the same module that is loaded and unloaded manually. Allowing for the difference between the working time reserve of the module (three shifts) and the model 3K151VF20 free-standing machine tool, which is serviced by an operator (and which has a norm reserve of 3,935 hours) and correcting for the equipment utilization coefficient

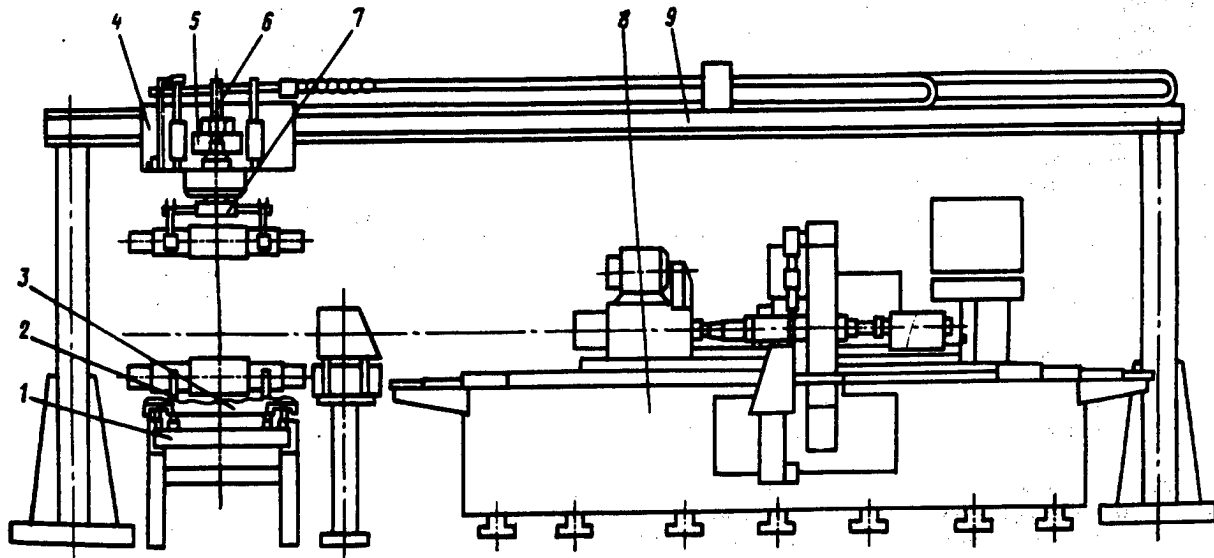

Figure 3.

(which is assumed to equal 0.7 for the module and 0.6 for the machine tool), one can figure that a 2.24-fold increase in productivity is achieved by including the machine tool in a module (given a 1:1.26 ratio of the per-piece time values). Two modules (robotized complexes) require only one operator and replace four ordinary machine tools.

Comparatively small components (diameter, 20 to 200 mm; length, 200 to 710 mm) are machined on the KhShK-001 grinding module. A floor-model-type industrial robot and a magazine in the form of a rotary pedestal onto which are hung four pallets whose base racks can be adjusted to the specified length of the workpiece and the diameters of its necks have turned out to be most suitable for use with the module. The pallets turn in the robot's working envelope upon instructions from an NC device.

Large components up to 280 mm in diameter, 1,400 mm in length, and 160 kg in mass necessitated the creation of another type of robotized complex. This is the KhShM-003 grinding module, which includes the following: a model 3M163BF2N3 grinder-semiautomaton (8) (Figure 3), a gantry (9), a frame (1) for a magazine with a horizontally placed pallet that can hold up to 12 components, a trolley (3) for components, a hoist (2), a gripper (7), a transfer arm (5), a carriage (4), and a hydraulic cylinder (6) to lift the gripper. The magazine for blanks and ground components is controlled by a single-coordinate NC device. This module, like the preceding one, has been designed to grind all of the necks and faces of the components of all classes of shafts in an automated cycle. It is also series produced.

The pallets of both grinding modules may be considered a tray in which the workpieces can follow in accordance with the in-shop production route. The components

machined on the modules are generally loaded and unloaded by changing pallets. This does not, however, exclude the variation in which the machined components are removed directly and the blanks are configured directly, for example, on the trolley of the storage unit of a robotized complex that is serviced by a portal industrial robot.

Including grinding as well as tooth- and thread-cutting and several other modules in an FMS makes it possible to organize the computer-integrated manufacturing of about 90 percent of all machine building components included in the class bodies of revolution.

A large number of robotized complexes and flexible production modules have been created and developed on the basis of NC machine tools. Each is capable of replacing two to three traditional machine tools in an FMS being designed. The higher the flexibility of the machine tool, the more equipment with which it is furnished, and the higher the level to which the machining of a component is concentrated on one machine tool, the more efficient is this type of replacement. Diagnosing the efficiency of a cutting tool and automatically replacing it by a stand-by tool are both important to the operation of a flexible production module.

A module to inspect body-of-revolution-class components with a maximum diameter of 400 mm and a mass up to 250 kg that is built into the FMS may be used to inspect the inner and outer diameters, linear dimensions of the inner and outer surfaces, groove widths, shape deviations, and locations of the surfaces and radii, etc.

The model IR200PMF4 flexible production module produced by the Ivanovo Machine Tool Production Association imeni the 50th Anniversary of the USSR is one example of a module that can be used for the integrated

machining of a wide range of three-dimensionally complex casing components. These modules are designed for products with a mass up to 60 kg and are mounted on a satellite table with a 200 x 200-mm working surface. This flexible production module can be used in drilling, hole-enlarging, reaming with the production of precise holes up to 80 mm in diameter, contour grinding (with linear and circular interpolation), and marking threads with sizes up to M16 in drilled holes. The flexible production module is produced in precision class II.

The model IR320PM4 universal machine tool with automatic tool and workpiece replacement, which is produced by the Ivanovo Machine Tool Production Association, has extensive production capabilities. By using circular feed to the tables, they can be used for circular milling and for precision machining of curvilinear profiles on a cylindrical surface. Lathing is also possible when the table's rotation frequency is increased. When a tool breaks down or when it becomes extremely worn, the machine tool automatically stops. A measuring head with feeler gauges automatically monitors machining precision. This is accompanied by automatic size correction.

The module for inspecting the casing components machined in the FMS can, for example, contain a VYe-155 coordinate-measuring machine, which is manufactured by the Kaunas Machine Tool Production Association imeni F. E. Dzerzhinskiy, the Vitebsk Tool-Grinding Machine Plant imeni the 22nd CPSU Congress, and several other plants. This machine makes it possible to inspect the geometric parameters of components with overall dimensions up to 250 x 250 x 250 mm and with a mass up to 100 kg.

For machining FMS, the inspection module is based on programmable testing and measuring machines using contact and contactless measuring devices (feeler gauges, etc.). A computer is used to control the module.

COPYRIGHT: Izdatelstvo "Mashinostroyeniye",  
Mashinostroitel, 1988

UDC 621.924.046-229.6

**Loading Device for Centerless Grinding Machines**  
*18610343b Moscow MASHINOSTROITEL in  
Russian No 11, Nov 88 p 15*

[Article by N. U. Chernenkiy, M. A. Kaganovskiy, engineers]

[Text] The loading device for the model 3A184 centerless grinding machine was developed by the Ukrorgstankinprom GPTEI [not further identified]. It is intended to feed cylindrical blanks into the machine tool's work area.

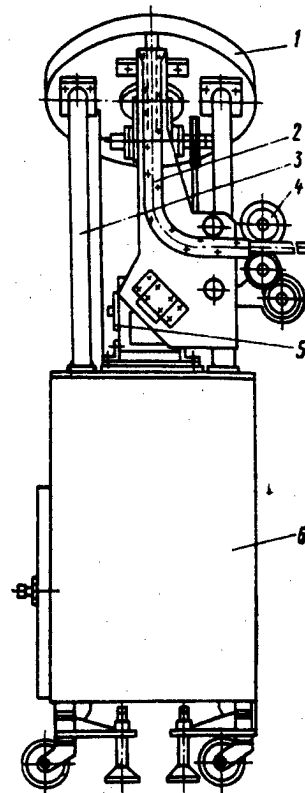

Figure 1.

The device (Figure 1) consists of a hopper (1) mounted onto pedestals (3) that are in turn mounted on the plate of the control cabinet (6), which contains electrical equipment to control the hopper's drive and feed mechanisms (2). The latter serves to store blanks in a storage chute and to continuously feed them, by using rollers (4), to the machine tool's blade. The drive (5) turns the hopper's disk with help from a V-belt transmission.

The motion is transmitted from the electric motor through a reducing gear and the V-belt transmission to the disk of the hopper (1), which grips the blanks by its small pockets and discharges them, one by one, into the storage chute of the feed mechanism (2). Rollers (4) that receive their motion from a separate electric drive are used to feed the blanks to the blade of the centerless grinding machine.

The loading device has a productivity of no less than 2,400 units per hour. The bin can operate continuously without any additional loading for at least 30 minutes. The device's overall dimensions are 900 x 650 x 1,620 mm, and its mass does not exceed 130 kg.

The loading device for centerless grinding machines has been installed at the Khrapunov (Moscow Oblast) and Zaporozhye tool plants imeni Voykov.

COPYRIGHT: Izdatelstvo "Mashinostroyeniye",  
Mashinostroitel, 1988

UDC 621.941.227-229.24

### Boring Head

18610343c Moscow MASHINOSTROITEL in Russian  
No 11, Nov 88 p 22

[Article by V. V. Belyanin, engineer]

[Text] Producing cylindrical holes belonging to the high-precision class is one of the most difficult production operations in machine building.

The boring head pictured in Figure 1 (author's certificate 1289614) makes it possible to move the cutting tool 1  $\mu\text{m}$  or less depending on its design. It consists of a cup (1); a tool holder (2), which has a cutting tool (4) fastened to it by a check screw (3); and a screw-nut (6) that is connected with the tool holder by its outer thread and with the screw labeled (5) by its inner thread. A dial (8) is mounted on screw (5), which is checked by screw (7). The screws labeled (9), which make contact with the screw-nut, have evenly spaced marks on the head's face.

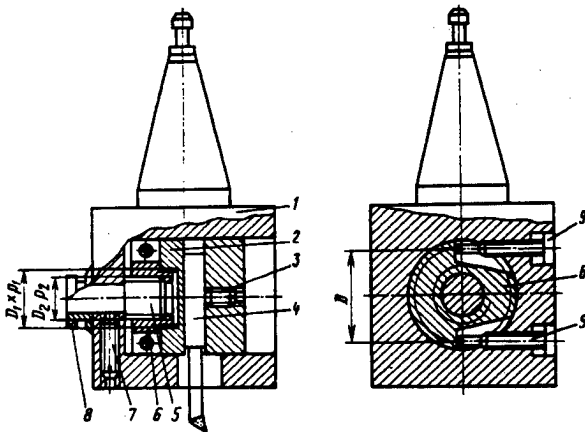

Figure 1.

The cutting tool can be precisely and roughly adjusted to the required size in the boring head.

In the second case, a single-point cutting tool with a precision up to 0.02 mm can be mounted both on and outside the machine tool, in which case both screws labeled (9) must make contact with the screw-nut. Screw (7) is then loosened, and the dial with screw (5) is turned. The tool holder moves with the cutting tool.

Mounting a cutting tool with a precision up to 0.001 mm is only possible on a machine tool after the fine chips have been removed and after the hole has been measured. Correcting the cutting tool's movement requires fixing screw (5) with a stopper and breaking the contact between one of the screws labeled (9) and the screw-nut.

The second screw labeled (9) is turned the required number of divisions. The linear movement of screw (9) causes the angular movement of the screw-nut, which, when engaged with the tool holder, moves it. After the cutting tool is located in the required position, the first screw labeled (9) is turned to the stop, thereby fixing the position of the screw-nut.

When an additional corrective adjustment is required, the first screw labeled (9) is again unscrewed, and the screw-nut is turned by the second screw labeled (9).

As a result of the small angular movement of the screw-nut, which has threads with different pitches on its outer and inner surfaces, the tool holder moves in an axial direction. When screw (9) is moved one division, this movement is determined in accordance with the following formula:

$$\Delta_t = [(P_1 - P_2)P_3]\pi Dn,$$

where  $\Delta_t$  is the amount that the tool holder moves (in millimeters);  $P_1$  is the pitch of the thread in screw (5) (in millimeters);  $P_2$  is the pitch of the thread in screw-nut (6) (in millimeters);  $P_3$  is the pitch of screw (9) (in millimeters);  $n$  is the number of divisions on screw (9) (in millimeters); and  $D$  is the geometric parameter characterizing the location of the contact points of screw (9) with the screw-nut.

Different combinations of  $P_1$ ,  $P_2$ ,  $P_3$ , and the parameter  $D$  can provide any axial movement of the tool holder.

The principle of measured angular movements of the screw-nut, which has a thread on the outer and inner surfaces, makes it possible to create mechanisms with a very small movement of the outgoing link as well as to use a thread with a medium or large pitch (which is more technologically feasible in the event of increased manufacturing precision requirements) in the designs.

From a design standpoint, another mechanism for effecting the angular movement of the screw-nut (a worm transmission, gearing, etc.) can be used instead of the screws labeled (9).

COPYRIGHT: Izdatelstvo "Mashinostroyeniye", Mashinostroitel, 1988

UDC 621.914.1; 621.914.31

### Increasing Precision of Milling Cylindrical Surfaces

18610343d Moscow MASHINOSTROITEL  
in Russian No 11, Nov 88 p 33

[Article by M. D. Medvedev, L. M. Natapov, engineers]

[Text] A method (Figure 1) of milling cylindrical surfaces (author's certificate 1174175) that significantly increases

the precision of the shape of the components in their longitudinal section has been developed.

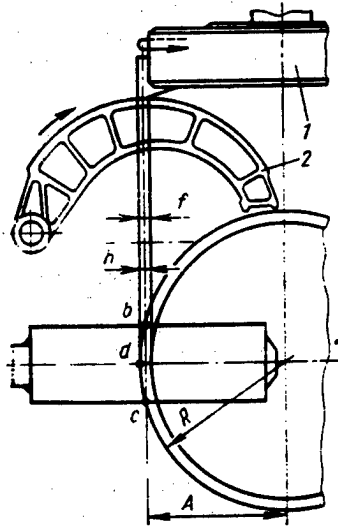

Figure 1.

A face milling cutter (1) is mounted on the spindle of a miller, and the blank being machined is mounted on its turning attachment with the possibility of their rotating around axes intersecting at a right angle. The width of the face milling cutter's trimming edges is selected to equal no less than the height  $h$  of the segment  $bdc$ , which is formed by the points  $b$  and  $c$ , which are where the circle (with the radius  $R$ ) on which the teeth of the milling cutter are located intersect the blank's faces. The distance  $A$  between the axes of the face milling cutter and the blank are selected by proceeding from the condition that  $A$  is greater than or equal to the quantity  $(R - f)$  but less than or equal to the quantity  $(R - h)$  (where  $f$  is the width of the milling cutter's trimming edge).

When all of the specified conditions are satisfied and when the rotary motions of the milling cutter and the blank are combined, a cylindrical surface with no shape errors in its longitudinal section is formed on the latter.

The method has been introduced into the operations of machining the radial surface of the block of a foot brake for a ZIL-131 automobile on a model FG261 special horizontal miller. The machined surface has a radius equal to 195 mm, the face milling cutter has a diameter of 400 mm, the milling width is 100 mm, the width  $f$  of the miller's trimming edges is 8 mm, and the distance  $A$  is equal to 193 mm. The error in the shape of the machined surfaces did not exceed 0.03 mm, which may be explained by factors that are purely technological.

The method makes it possible to significantly increase the precision of milling short cylindrical surfaces and eliminate errors in their shape in longitudinal section.

COPYRIGHT: Izdatelstvo "Mashinostroyeniye", Mashinostroitel, 1988

UDC 621.9.06-220.33:531.45

**Rolling-Contact Bearing With Enhanced Damping**  
*18610343e Moscow MASHINOSTROITEL*  
*in Russian No 11, Nov 88 pp 33-34*

[Article by A. N. Teuges, engineer, and A. G. Pavlov, candidate of technical sciences]

[Text] The precision of the rotation of a spindle mounted in rolling-contact bearings may be further increased by minimizing the kinematic and dynamic errors caused by the state of the mounting surfaces, the quality with which the bearing has been assembled and regulated, and the distinctive features of the spindle's dynamics. When regulating the clearance/tension in a support with a rolling-contact bearing by changing the mounting size to minimize the kinematic rotation error in the system, the wear to the bearing surfaces and heat liberation increase. In view of this, further regulation of the clearance/tension is stopped.

In the case of ordinary rolling-contact bearings, it is not possible to reduce the dynamic rotation error to a minimum because of the intensive forced vibrations of the spindle in regions close to resonance. This is due to the fact that there is little damping in such a system and that the damping is connected with the amount of clearance/tension in the bearing. In practical terms, the precision of the spindle's rotation in the bearing supports is increased by changing the dynamic properties of the rotation system to obtain the maximum possible damping and create normal operating temperature conditions. The clearance/tension in the bearing is regulated by changing the mounting size of the hole for the outer ring, which is done by pumping fluid (machine oil) with a pressure pulse. This results in an increase in the discharge of heat from the bearing, which makes it possible to expand the limits within which the clearance/tension can be regulated and in an increase in the rotation precision (the amount of kinematic error due to clearance/tension is reduced) while the heat conditions are maintained.

The pressure pulse continuously changes the mounting size (around the average value), which affects the system's parameters: rigidity, damping, and natural vibration frequency. The vibration system (spindle—rolling-contact bearing) acquires a new dynamic characteristic, i.e., efficient damping in the resonance zone. Fluctuations in the system's natural frequency result in a smoothing of its amplitude-frequency characteristics.

Figure 1 illustrates the bearing support (author's certificate 1300219) for a spindle node with fluid pumping and pressure pulsing. A diaphragm bushing (5) is pressed in the body (6). The bearing's inner ring is conical. The connecting valves (4) and (7) serve to pump fluid (to feed



and discharge oil) from a pulser through annular grooves into the body's openings. The bearing's inner ring, its bushing (3), its lock nuts (2), and the conical neck of the spindle form a system for the preliminary regulation of the clearance/tension in the bearing. The diaphragm bushing is made of alloyed steel that has been heat treated to a hardness between 27 and 35 HRC. The bushing opening has a precision quality between 6 and 7, the surface roughness  $R_a$  is between 0.6 and 1.2  $\mu\text{m}$ , and the deformed wall has a thickness of 0.4 to 0.5 mm.

After assembly, the clearance/tension in the bearing is regulated in pressure pulsations from 0 to 2.5 MPa with a frequency of 1 to 3 Hz. In the case where there is clearance in the bearing, the spindle vibrates with an amplitude equal to half the clearance, which is conveniently observed by using twisted spring micrometers.

Preliminary regulation (zero clearance) is performed manually with the spindle being fastened by a tightening bolt (2) until the vibrations stop. Next, the regulation is continued in dynamics, i.e., the average value of the pressure pulses is selected in accordance with the minimum beating of the spindle's control surface, and the fluid flow rate is selected in accordance with the normal temperature conditions (pressure, 2.0 to 4.0 MPa). The support's damping properties are maximally improved when a steady pressure pulse that approaches binary white noise from the standpoint of its properties is provided.

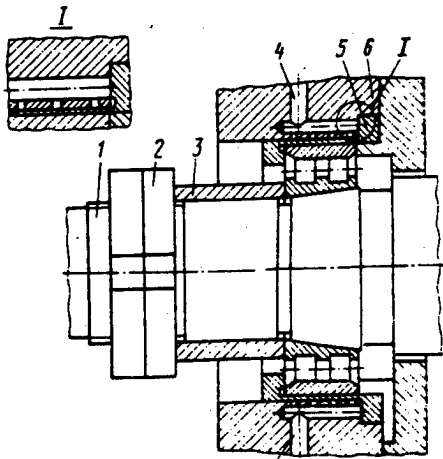

Figure 1.

This configuration of a rolling-contact bearing provides the following advantages:

The precision of the shaft's rotation is increased thanks to the continuous changing of the mounting size of the clamping bushing (this change is effected by pumping fluid with a pressure pulse);

The kinematic errors of the rotation are reduced to a minimum thanks to the stabilization of the node's temperature, and the dynamic rotation errors are reduced to a minimum thanks to the oscillation of the parameters of the vibration system and effective damping in the resonance zone (the logarithmic decrement of the vibrations is increased by 0.2 to 0.3 on average, reaching 0.7 to 0.8);

The operations entailed in regulating the preliminary (zero) clearance/tension in the bearing is simplified, and special attachments to measure the clearance/tension are eliminated;

Remote control of the mounting size of the clamping bushing by controlling the fluid's pressure pulse becomes possible.

Using the support that has been developed in a precision lathe made it possible to reduce the error in workpieces' shapes an average of 1.5- to 2.5-fold, reduce surface roughness, and obtain an economic impact of more than 23,000 rubles.

COPYRIGHT: Izdatelstvo "Mashinostroyeniye", Mashinostroitel, 1988

UDC 621.882.3-182.8

### Split Ball Nut

18610343f Moscow MASHINOSTROITEL in Russian  
No 11, Nov 88 p 34

[Article by V. F. Salomatin, candidate of technical sciences]

[Text] In existing ball screw mechanisms used for precision adjusting and accelerated movements, the nut is constantly engaged with the screw. This results in the premature wear of the ball screw mechanism. The possibility of opening the kinematic chain of the forward drive by disengaging the nut from the screw increases the ball screw mechanism's service life. Accelerated idling movements may be made by using a less expensive mechanism (for example, a rack and pinion) with a high efficiency, which does not provide high positioning precision because of the low reduction, and small, precise adjusting movements may be made with a ball screw mechanism with a closed nut that has been disengaged from the pinion rack.

The split ball nut (author's certificate 1260614) consists of two halves (2) and (6) (Figure 1a) with a jointing plane passing through the nut's axis. The halves are capable of moving along the guides of a movable actuator (7) (Figure 1b) that is perpendicular to the nut's axis.

UDC 621.825.7.031.4

**Hydraulic Elastic Expanding Clutch**

18610343g Moscow MASHINOSTROITEL in Russian  
No 11, Nov 88 pp 34-35

[Article by B. P. Spruogis, candidate of technical sciences, L. A. Zubavichyus]

[Text] The hydraulic elastic expanding clutch (author's certificate 1295071) created at the Vilnius Construction Engineering Institute is intended for transmitting torque and damping any vibrations and dynamic loads arising in the process, particularly in drives with a wide rotation frequency range to increase the damping properties in the required vibration-shielding frequency range. The drive and driven half-couplings interact by the contact of their finger supports.

An electronic circuit to control the frequency damping appearing in the component part of the clutch has been developed to damp the harmful vibrations arising in the actuator when the shaft rotates. The circuit consists of a vibration pickup (4), a signal amplifier-limiter (3), a filter-amplifier (1), and a power amplifier (13) that regulates the magnetic threshold of the signal fed to the coil of the magnetic control choke (10). The filter-amplifier (1) transmits the signal from a frequency-assigning device (2).

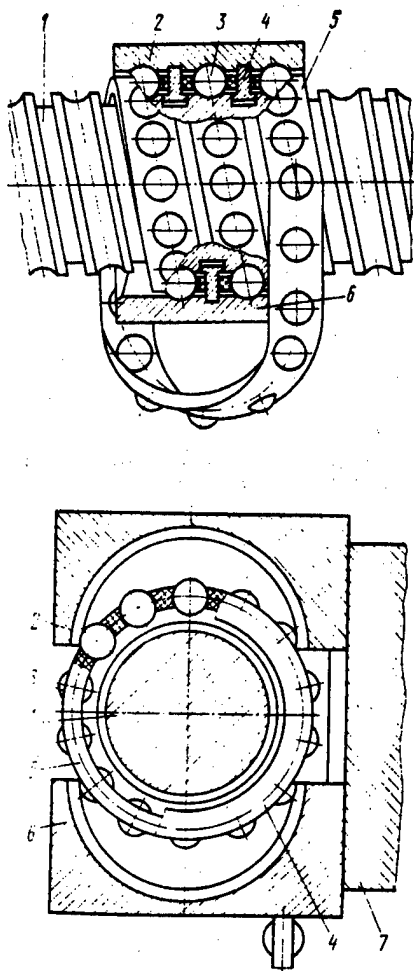

Figure 1.

When the nut's halves are split (Figure 1b), the deformable helical torsion spring (4), which is located in helical channels between the nut's radial grooves, is opened, thereby acting on the section of the flexible closed separator (5) that is located in the nut's operating zone and squeezing the latter together with the balls (3) mounted on it in a radial direction from the screw (1) until the balls leave the screw's radial grooves completely.

In the nut's closed position, the deformable helical torsion spring is in a compressed state, and it interacts with both halves of the nut.

To compensate for the change in the length of the section located in the nut's operating zone, a separator may be fashioned from elastic material on the connecting pieces between the ball sockets.

COPYRIGHT: Izdatelstvo "Mashinostroyeniye", Mashinostroitel, 1988

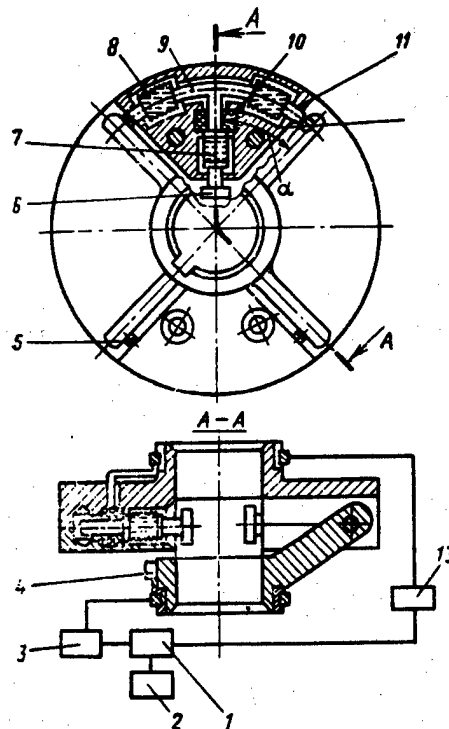

Figure 1.

When the driving half-coupling rotates, the finger supports (5) press against the finger supports (11) connected with the tangentially located bellows (8) of the driven half-coupling (left and right, depending on the direction of the rotation). Magnetic fluid from the right bellows is extruded to a T-shaped line (9) to a radially located bellows (7) while the opposite bellows (the left one) is thrust into a restraining arm (12). During the rotation, the magnetic fluid in the line (9) circulates at the same frequency as the exciting force of the torsional vibrations. The passage of the magnetic fluid through the radial compartment of the line (9) is automatically monitored by a magnetic choke (10). Its coil is connected with the electronic unit controlling the damping frequency, thanks to which harmful vibrations arising when the shaft rotates are eliminated. For example, at a rotation frequency of 150 to 300 Hz, there arise harmful mechanical vibrations that this device damps.

The principle of the circuit's automatic operation are as follows. A piezoelement helps convert the mechanical vibrations of the shaft into electrical oscillations. Next, an operational amplifier amplifies them to the necessary voltage, and a filter helps cut the unnecessary frequency (150 to 300 Hz) out of the full frequency spectrum. The signal that is conditioned in this manner is fed to a control switch by output transistors that, depending on the frequency, are either closed or opened, thereby controlling the electromagnet. The circuit's electronic base is based on microcircuits and transistors with dipole feed.

By changing the magnetic flux of the choke (10) it is possible to change the viscosity of the magnetic fluid in the radial compartment of the line (9) where the main fluid circulation is occurring (although partial damping is obtained when the bellows (8) inflate), thereby absorbing the harmful torsional vibrations and dynamic loads in the necessary frequency range. The stronger the current through the choke's (10) coil, the greater the viscosity of the fluid and the rigidity of the clutch. The action of the magnetic fluid is adequate for the operation. The action of the magnetized hydraulic is adequate damper. As the rotation frequency increases, the loads (6) under the effect of the centrifugal forces of the mass and the magnetic fluid located in the radial bellows (7) try to restore the clutch's damping angle  $\alpha$ .

Experimental tests have demonstrated that the specified clutches have high torsional vibration-damping properties and tolerate dynamic loads in the required vibration-shielding frequency range.

COPYRIGHT: Izdatelstvo "Mashinostroyeniye", Mashinostroitel, 1988

621.791.763.1.037

### Spot Welding Unit

18610343h Moscow MASHINOSTROITEL in Russian  
No 11, Nov 88 p 35

[Article by A. N. Ganzha, engineer]

[Text] The Perm production association Motorostroitel imeni Ya. M. Sverdlov developed and introduced a unit

(author's certificate 1214367) for welding sheet products and foil with a welding current of 100 A. Its design includes a circuit breaker that feeds current only after the electrode is pressed to the product with the required (calibrated) force. The force with which the electrode is pressed ranges from 0 to 15 kg.

A column (2) that has a lead screw (3) and a table (4) with a current lead (5) is mounted onto a cast frame (1). The height of the table's movement is fixed by a knob (18) in accordance with readings from a scale (19).

A console (15) with an air distributor (17) is fastened to the upper end of the column. When the knob (16) is turned, the lead screw moves the table. A casing (9) containing an electrode holder (11) with a current lead (8), an adapter (7), and a detachable electrode (6) is fastened on the left on the console (15). Mounted on the upper part of the casing is a crosspiece (10) with an axis (12) that has a loaded lever equipped with a scale and weight (13) fastened to it in a manner that allows it to move.

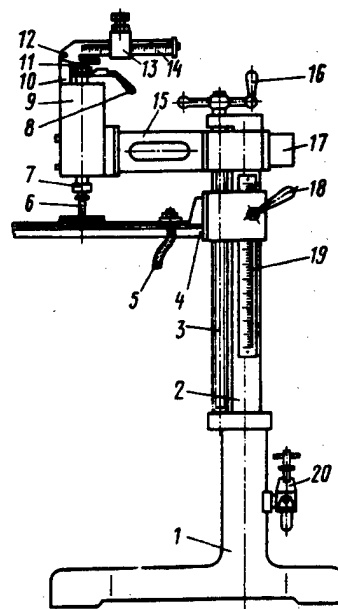

Figure 1.

The casing contains an electrical circuit breaker with a pneumatic cylinder (not shown) to which compressed air is fed through an air preparation node (20). The unit's overall dimensions are 660 x 920 x 1,295 mm.

Previously, products 10 to 265 mm high were welded manually with a welding gun. This frequently resulted in the deformation of the place where the components made of sheet material were joined because the force from the compression of the components that was created by the worker's hand could not be instantaneously eliminated.

After the introduction of the unit that presses the components together with a stable force, defective production due to faulty fusion and burnthroughs was completely eliminated. The savings resulting from the reduction in defective production and the mechanization of manual labor after one unit was introduced amounted to about 10,000 rubles annually.

COPYRIGHT: Izdatelstvo "Mashinostroyeniye", Mashinostroitel, 1988

UDC 621.825.7

### Elastic Tooth-type Coupling

18610343i Moscow MASHINOSTROITEL in Russian  
No 11, Nov 88 pp 35-36

[Article by Yu. M. Guzenko, engineer, and M. S. Kovalyev and V. V. Karachun, candidates of technical sciences]

[Text] In the proposed coupling (author's certificate 981731, 1257310), a drive half-coupling (1) in the form of a gear (3) with inner teeth engages pinions (5) mounted on axes (2) that are in turn mounted on a driven half-coupling (4) evenly along the circumference. The radial slots (9) of the pinions are located at an angle to one another. Elastic elements in the form of bundles of metal (8) and rubber (7) plates are located by their ends in the radial slots of the pinions, thereby forming a closed loop together with the latter. The elastic elements are equipped with a common multifaceted insert (10) made of elastic material. Their faces interact with the metal plates and flats (6) of the pinions. The number of faces an insert has equals the total number of pinions and bundles of elastic plates. The radial slots should be deep enough to reliably hold the ends of the bundles of elastic plates, and their width should be somewhat less than the thickness of a bundle so as to provide an assembly with some tension.

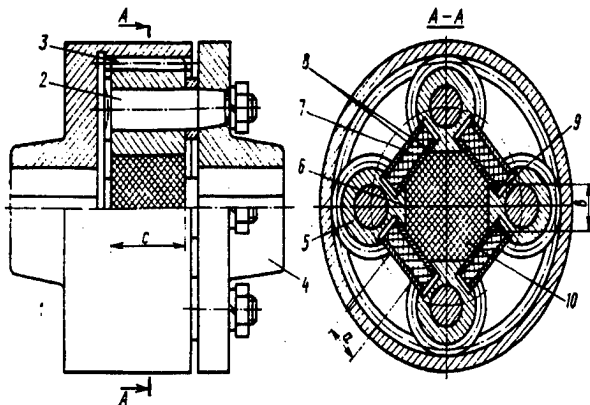

Figure 1.

The coupling's geometric dimensions are selected such that the distance  $a$  between the pinions and the length  $b$  of the flats are equal. This makes it possible to give the multifaceted insert the correct shape and makes it easier to manufacture. The width of the elastic elements may be equal to or somewhat less than the width  $c$  of the pinions. The bundles operate for compound bending with the simultaneous shifting of the plates, and the insert operates for shifting and simultaneous compression. This combination of the deformation of the elastic elements and inserts makes it possible to give the coupling's connection a nonlinear characteristic so as to provide the maximum elastic damping capability. The coupling's load-carrying capacity is increased thanks to the auxiliary linkage of the pinions with the help of the insert and thanks to its interaction with the bundles' metal plates. The presence of an insert makes it possible to increase the coupling's reliability during overloads since it limits the deformation of the elastic plates somewhat and eliminates the probability that they will break or jump out of the pinions' radial slots.

When the drive half-coupling rotates, the gear turns the pinions that, once connected by the elastic element, transmit the torque through the axis (2) to the driven half-coupling. Both half-couplings are connected with a certain relative turn. After the coupling is disconnected, the pinions rotate to their initial position under the effect of the elastic elements.

The coupling is reversible. It is simple to manufacture and operates reliably.

COPYRIGHT: Izdatelstvo "Mashinostroyeniye", Mashinostroitel, 1988

UDC 621.926.55

### Vibratory Mills

18610343j Moscow MASHINOSTROITEL in Russian  
No 11, Nov 88 pp 36-37

[Article by B. Ya. Opirskiy and P. D. Denisov, candidates of technical sciences]

[Text] Vibratory mills may be used in practically any branch of industry; for example, they may be used to crush and pulverize mineral ores, useful minerals, building materials, silicate and ceramic products, foodstuffs, etc. Vibratory mills with steel balls or rods are used to pulverize materials with medium friability (class IV according to L. I. Baron), whereas self-pulverizing vibratory mills are used for materials that are either easy or very easy to crush (class V or VI). In these operations, vibratory mills are three to four times more productive than are the ball-tube and rod mills that have become prevalent.

A mill's efficiency is determined by the degree to which materials are crushed. However, the latest research shows that a minimal amount of energy is expended

when crushing an initially lumpy product into pieces with a specified size. They are then crushed in mills adjusted to the lesser output product size, etc. In practice, up to five stages of crushing are used. When materials belonging to any friability class are crushed, the vibratory mills in the fine and superfine crushing stages have a significantly higher efficiency than do other types of mills.

The lack of reliable, high-productivity vibratory mill designs has kept vibratory mills from becoming widespread in industry. Modern one- and two-container mills are generally furnished with a single-vibrator drive. When this type of configuration is used, strong specific loads that frequently lead to a breakdown are created at the place where the vibration exciter is fastened to the tooling. These flaws may be avoided by using a multivibrator drive. Its vibration exciter consists of a body (Figure 1) in which an eccentric shaft (1) has been mounted on two supports. To make the mill easier to start and eliminate the excessive swinging of its tooling, unbalanced masses have been mounted on the eccentric shaft by using auxiliary bearings (3). When resonance occurs, only the shaft rotates. Then, when the electric motors enter their rated mode, the container gradually swings, and the eccentric shaft "grips" the unbalanced masses. The body of the vibration exciter is fastened at any point of the mill's tooling by bolts. One- and two-container mills are combined into units by such vibration exciters.

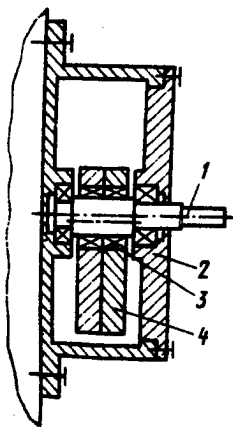

Figure 1.

One-container mills (author's certificate 688222) are used primarily for the self-pulverization of materials that are either easy or very easy to crush. The initial material is fed through a loading window into the tooling where it is crushed under the effect of vibrations. The crushed material is dispersed through the perforated bottom.

Two-container vibratory mills (author's certificate 1034776) are used to crush materials of average friability. Crushing such materials requires their repeated collision with the grinding bodies and the tooling. The

mill has a two-container tooling (2) (Figure 2) that is flexibly mounted on a fixed base. The adjacent sides of the containers are joined in a common barrier wall with an opening in back of the facing wall. The tooling's right container is loaded with crushed material at the opposite facing wall. At the same facing wall, an unloading-separating chute (1) is mounted in the left container. The tooling is loaded 50 to 60 percent with grinding bodies. Under the action of the vibrations, the material and grinding bodies mix along a spiral running along the container. Then, at the facing wall they are moved from the right container to the left, and they proceed to the unloading-separating chute. The material and grinding bodies rise up above the grate and are fed into a chamber over the grate in a steady, continuous mode. The product dispersed along the race is transported into a container (3), and the fraction with the grinding bodies that remains above the grate is returned to the right container for further crushing.

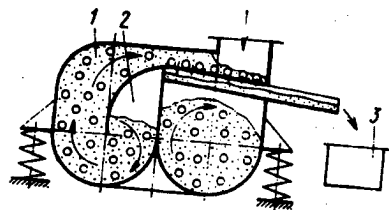

Figure 2.

Joining multiple vibration exciters into a vibratory mill unit makes it possible to concentrate the inducing force along the entire perimeter of the mill's tooling, which in turn makes it possible to reduce the stresses arising during the operation and hence the amount of metal used in the tooling. This type of configuration makes it possible to create vibratory mills with an extended tooling since there is no need to bore out mountings under the bearing from one unit as in the case of a traditional one- or two-vibrator drive.

Repairing the mill has been made significantly easier: failed vibration exciters are easily and quickly removed and replaced with new ones.

The Lvov Forestry Engineering Institute has developed a similar-sized series of vibration exciters designed for different inducing forces. They may be installed in different vibratory mill designs. The total inducing force required is provided both by the number of vibration exciters and their individual inducing forces and by the required rotation phase shift angles. It is impossible to implement any kinematic links between the vibration exciters' shafts in this type of configuration. For this reason, the rotation phase shift angles required must be provided dynamically. The mass and inertial moment of the tooling and the place where the vibration exciters are located on it are the main factors influencing the angles of the vibration exciters' phase shifts. The institute has developed a method of selecting the key parameters of vibratory mills equipped with a multivibrator drive.

COPYRIGHT: Izdatelstvo "Mashinostroyeniye",  
Mashinostroitel, 1988

UDC 620.172.24.05-52

### Break Testing Diaphragm Specimens

18610343k Moscow MASHINOSTROITEL in Russian  
No 11, Nov 88 p 37

[Article by L. F. Semenychev, engineer]

[Text] This device, which is intended for testing specimens by extrusion with the required rate of increase in the test load, includes a modernized (with a modified operating cycle) type TS-2M instrument for measuring hardness according to the Brinell method. The instrument is located on a pedestal in which a pump unit with water and electrical equipment are located. Mounted on the instrument's large-lever suspension along with a set of weights is a measuring tank (4) of lightweight design. It has indicator tubes and a scale and water mass (volume) that has been calibrated by a dynamometer. When the pump unit is in operation, this water mass is fed by an electric pump from the tank (1) through a pipe (3) with a throttling orifice. At the conclusion of the test it is drained through a pipe (2) into the pump unit's tank with the help of a valve that is located in the measuring tank and controlled by a knob. A shock absorber mounted on the instrument's body and regulated along its height relative to the weight lever has been provided to soften the impact at the moment when the specimen breaks. A lamp for local illumination is mounted on the level wall of the instrument's body, and a crosspiece with a control panel is mounted on the pedestal's right wall. The instrument's electrical circuit has been modified. The magnetic trigger and resistor have been moved to the bottom with the electrical equipment.

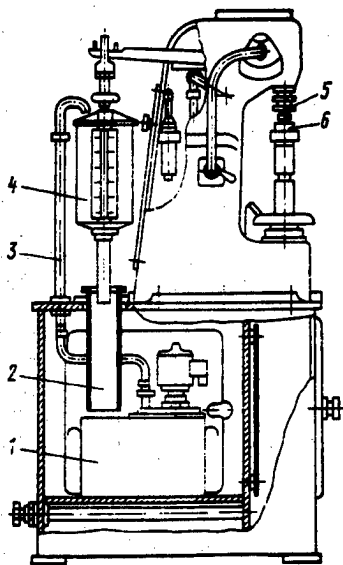

Figure 1.

A specimen is tested in the attachment (6) after being preliminarily pressed to the ball of the mandrel (5) by the instrument's flywheel.

The device operates as a semiautomaton. The configuration and pressing and removal of the specimens, the recording of the values of the test load, and the drainage of the water from the tank are all performed manually. Pushing the "start" button switches on the electric motor of the drive that loads the instrument's lever system. A base roller is removed from the weight lever, and a load of 200 kgf (that is created by the mass from the measuring tank) is applied onto the test specimen through the released lever system and the mandrel. At the same time, a microswitch on the weight lever is released, and the "load and electric pump" signal lamp is turned on. As water enters from the measuring tank (1 to 1.5 L/min), the test load increases at a rate of 60 to 90 kgf/min.

The base roller is released to where the specimen is deformed to the breaking point. After the limit switch (which, before the modernization, resulted in the reversal of the electric motor and the return of the lever system to its initial position, i.e., it kept the specimen under a load) has been activated, the base roller stops thanks to the fact that the electric motor has been switched off. After the specimen has broken, the weight lever (which is lightly braked by a shock absorber) falls onto the lowered base roller, presses a microswitch and disconnects the electric pump, turns on the drive's electric motor in reverse, returns the lever system with the base roller to the initial position, switches the limit switch, and disconnects the drive's electric motor. The water level in the measuring tank is kept from overflowing by a valve after the load under which the specimen broke is recorded.

The electrical circuit provides an adjustment mode that permits the separate connection of the electric pump and the drives responsible for loading the lever system and the loading and return to the initial position.

Specimens may be tested with a load ranging from 200 to 680 kgf. The error in loads does not exceed 3 percent. The device's overall dimensions are 960 x 660 x 1,680 mm. It has a mass of 480 kg.

COPYRIGHT: Izdatelstvo "Mashinostroyeniye",  
Mashinostroitel, 1988

### New Electrospark Production Equipment

18610343l Moscow MASHINOSTROITEL in Russian  
No 11, Nov 88 p 37

[Article: "In Brief"]

[Text] In the shops of the Odessa production association Avtosborochnyy Zavod [Automotive Assembly Plant], all tools and equipment undergo hardening, alloying, and marking on an electrospark unit without any surface

damage. This production process, which makes it possible to conserve tool steels, was developed at the Spetstekhosnastka [Special Production Association] Scientific Production Association where the series production of the STO-2 electrospark unit is also being debugged. The unit is small with respect to its overall dimensions and weighs only 13 kg.

COPYRIGHT: Izdatelstvo "Mashinostroyeniye", Mashinostroitel, 1988

UDC 621.865.8-83.81

### Planning of Electromechanical Industrial Robot Drives

18610157B Moscow STANKI I INSTRUMENT  
in Russian No 9, Sep 88 pp 13-14

[Article by Ye. P. Soldatkin and A. A. Uvarov]

[Abstract] The process involved in planning electromechanical industrial robot drives must consider the characteristics of the drive itself as well as the environment in which the drive will operate, including the availability of human operators to assist the robot, the type of operation performed and the type of control system used. A flow chart is presented illustrating the planning of an industrial robot electromechanical drive considering all these factors. An example is presented of the planning of an electromechanical robot drive to achieve a reliability of 5000 hours MTBF, transfer ratio 1200:1, efficiency at least 70 percent, minimum torque transmitted 150 N x m, torsional rigidity at least  $0.4 \times 10^{-4}$  N x m/rad, minimum kinetic energy of rotation of drive elements, with moment of inertia not over  $10^{-2}$  kg x m<sup>2</sup>, play not over 15', mass 6 kg, dimensions not over 400 x 150 x 150 mm. A photograph of the drive is presented. Tests showed that the reliability of the drive can be improved by the use of a self-adjusting flexible liner or wave drive system with variable contour to reduce deformation of the shell. Figures 3, references 3: Russian.

UDC 658.512.011.56:621.865.8-236.58

### System for Automated Planning of Electromagnetic Industrial Robot Clamping Devices

18610157A Moscow STANKI I INSTRUMENT  
in Russian No 9, Sep 88 pp 11-13

[Article by Yu. D. Zhabotinskiy and A. K. Krikov]

[Abstract] Design of an electromagnetic clamping device for an industrial robot is a complex process due to the great number of iterative computations required. This article suggests a calculation method for the design of such devices which considers the required holding force, determined by the mass of the object to be held and the acceleration of the movement of the object by the industrial robot. The design method has been implemented as an application software package for the

DVK-2M microcomputer. The program was written in BASIC, and is intended to be used in coordination with experimental studies with acceleration sensors. Figures 4, references 4: Russian.

UDC 621.865.8.004.14:621.757

### Dynamic Analysis of Robot Assembly of Cylindrical Joints

18610064B Moscow VESTNIK MASHINOSTROYENIYA  
in Russian No 6, Jun 88 pp 41-47

[Article by M. N. Polishchuk and L. S. Yampolskiy, candidates of technical sciences, I. A. Nishchenko, candidate of physical-mathematical sciences, and Yu. V. Samokhatko, engineer]

[Abstract] A model is suggested for description and analysis of the process of assembly of parts using inexpensive series-produced robots allowing dynamic analysis of the process of assembly of cylindrical parts considering the working conditions and active correction rule used for compensation for errors in relative placement of parts. The stages include scanning, sintering and placement of parts. Expressions are presented which describe the force oscillations of a system intended to overcome part placement errors. Experimental testing of the method indicates that it can yield an increase in productivity of the assembly of cylindrical parts by 55 percent in comparison to previously known vibration assembly methods. Figure 6, references 9: Russian.

UDC 669.1.017

### Replacement of Nonferrous Metals With High-Strength Cast Iron

18610064A Moscow VESTNIK MASHINOSTROYENIYA  
in Russian No 6, Jun 88 pp 39-41

[Article by L. A. Solntsev, V. D. Shifrin, T. K. Veliyev and R. S. Safarov, candidates of technical sciences]

[Abstract] High-strength cast iron with spheroidal graphite can be used as an anticorrosion material to replace brass in certain applications. This requires a change in the design of the parts involved to achieve more favorable distribution of contact loads. A cast-iron nut used with a type 40Kh steel spindle was tested, showing a decrease in contact area with wear due to an increase in surface roughness, but a decrease in coefficient of friction due to the lubricating antifriction effect of the graphite inclusions.

UDC 621.824.42.002.2

**Increasing Accuracy of Grinding Interior and Exterior Surfaces of Shaped Joints**

18610064C Moscow VESTNIK MASHINOSTROYENIYA in Russian No 6, Jun 88 pp 47-52

[Article by A. I. Timchenko, candidate of technical sciences and A. V. Bogolyubov, engineer]

[Abstract] Replacement of pin and spline joints by shaped joints allowed the specialists of the Novokramatorsk Machine-Building Plant imeni V. I. Lenin to decrease the mass of the drive unit of the ESh-6-60 excavator by 1700 kg in 1956-1958. Studies have shown that the wear and noise of RK-3 shaped joints (three-face equiaxial contour) is superior. New methods have been developed for generating the shape of profiles by single-axis forced harmonic movement of cutting tools. This article describes a process involving shaping of internal and external profile surfaces by rotary motion of the part being worked at a constant angular speed with single-coordinate reciprocating movement of a flat grinding disk according to a rule which considers the change in dimensions of the grinding disk as it is used. The process provides accuracy of shape generation 1-2 quality levels higher than when two-coordinate movement of the grinding disk is used, plus higher productivity. Micro-processor-controlled machine tools can be used for this process with parallel placement of the axis of the grinding disk and the surface being generated. Figures 8, references 8: Russian.

UDC 621.9.079:62-589.6

**Influence of Epilam on Antiskip Properties of Guides**

18610157C Moscow STANKI I INSTRUMENT in Russian No 9, Sep 88 pp 26-28

[Article by A. S. Lapidus, N. V. Gitis and B. N. Chizhov]

[Abstract] An estimate is presented of the effectiveness of epilam type 6SFK-180-05 containing 0.5 percent active additive, used both as a coating on the working surfaces and as an additive to oil, to increase the antiskip properties of feed guide mechanisms. Tests were performed with friction of specimens made of type SCh 25 cast iron, UP-5-250 epoxy compound and PT textolite on a disk of SCh 25 cast iron. Epilam was poured on a degreased and dried disk, rubbed in and dried at 20°C for 2-3 hours. Epilam was found to decrease jumping and skipping, but only temporarily. When the specimens were immersed in epilam, dried in air, then tested with I-40A oil, the effectiveness of the epilam disappeared still more quickly. Even hot epilam treatment did not improve the results. The use of standard antifricition oils and polymer materials is more effective. References 5: Russian.

UDC 621.514.012.4

**Reverse Expansion in Rotary Compressor With Rolling Rotor**

18610122C Moscow KHIMICHESKOYE I NEFTYANOYE MASHINOSTROYENIYE in Russian No 7, Jul 88 pp 22-23

[Article by V. Ye. Shcherba, candidate of technical sciences, and I. S. Berezin and I. A. Skripnik, engineers]

[Abstract] "Mikrokriogenmash" Scientific-Production Association has developed a method for calculating the process of reverse expansion in a rotary compressor with a rolling rotor with single-phase working fluid and estimated the influence of the process on productivity and efficiency. A comparison of the results of calculation of the process by analytic solution and numerical integration of the system of differential equations produced to form the mathematical model of the process shows good agreement. The experiment indicates linear change in pressure and temperature in the process of reverse expansion. With a pressure increase of 6-7, the maximum deviation in determination of the volumetric factor by the two methods is over 10 percent. This disagreement can be decreased where the pressure at the end of the reverse expansion process does not reach the intake pressure. Figures 3, references 4: Russian.

UDC 621.9.029:621.923.6

**Use and Sharpening of Complex Multiple-Edge Tools**

18610122B Moscow KHIMICHESKOYE I NEFTYANOYE MASHINOSTROYENIYE in Russian No 7, Jul 88 pp 35

[Article by S. V. Bulgakov and O. L. Paramey, engineers]

[Abstract] The Sumy Scientific-Production Association imeni M. V. Frunze has developed a special angled head allowing the ZB667 semiautomatic sharpening machine to operate in automatic mode when sharpening the forward surfaces of multiple-edge metal-cutting tools of both simple and complex shape. The head can sharpen both straight-tooth tools and tools with teeth which slope both right and left. Installation of the special head on one ZB667 machine increased the variety of metal-cutting tools which could be sharpened in semiautomatic mode by 50 percent, significantly improving the quality of work performed as well. Figure 1, references 2: Russian.

**Creation of Rotary Lines to Form Rubber Products**

18610122A Moscow KHIMICHESKOYE I NEFTYANOYE MASHINOSTROYENIYE in Russian No 7, Jul 88 pp 1-2

[Article by A. S. Nefedov, engineer]

[Abstract] The All-Union Scientific Research Institute for Rubber Product Machine Building has developed 10 plans for automatic rotary and rotary-conveyor production lines. Two machines were shipped last year for the manufacture of rubber screens, plus two automatic



**JPRS-ueq-89-005**  
**24 march 1989**

**46 Industrial Technology, Planning, Productivity**

rotary lines for pouring and cooling of rubber mixtures and an automatic rotary-conveyor line for the manufacture of railroad ties. Some of the problems encountered in the manufacture of rubber products on such lines are noted. It is reported that these problems indicate that the

technology of rubber manufacture today does not allow the development of high productivity automatic rotary and rotary-conveyor lines. The creation and introduction of such lines will require further efforts by designers and technologists.

UDC 629.124.9.078.039

**Small Amphibious Air Cushion Vessels for National Economy**

18610348 Moscow SUDOSTROYENIYE in Russian pp 3-6

[Article by V. A. Vavilin, V. V. Protsenko, and A. V. Rubinov]

[Text] The air cushion crew boat is an irreplaceable vehicle in regions with an insufficiently developed road network and shallow rivers. Work to design an eight-seat boat of this type in our country began in 1975. When the design was being developed it became necessary to address the problem of ensuring the possibility of shipping the vessel to hard-to-reach operating regions in the cargo hold of an Mi-6 helicopter. This placed restrictions on the boat's overall dimensions and has a pronounced effect on its engineering decisions. As a result, the boat Bars, which was designed for class R of the RSFSR River Registry, has the following main components and characteristics (Figure 1):

Length, m	7.0
Width, m	
Overall size	3.35
During transport	2.5
Height without mast, m	1.84
Water displacement, t	
Total	2.50
Greatest	2.65
Capacity, persons	7-9
Speed, km/h	
In calm water	70
During a head wind of 5 m/s and 0.25-m waves	45

The boat, which is manufactured from a light alloy, is intended to be operated on rivers and in water reservoirs at a wave height of 0.75 m and in a wind up to 15 m/s, in swampy areas and in reed thickets up to a height that does not impede the view from the pilot's cabin, in snow and on solid and broken ice, in icy slush, and in sections of unforested dry land with outside air temperatures ranging from minus 40 to plus 40°C. The boat has a hovering height of 0.45 m. When the boat is in its water-displacing position, it may be operated at a wave height of up to 1.2 m. The boat stays afloat when any one of its compartments is submerged, and design measures exclude the possibility of having two adjacent compartments submerged when the length of a puncture does not exceed 10 percent of the hull length.

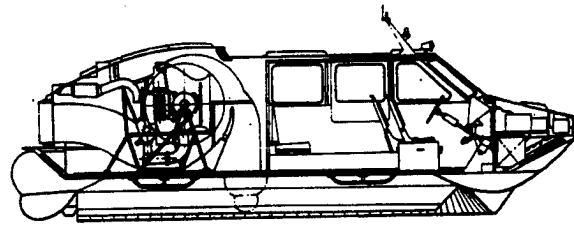

Figure 1. Boat "Bars" Underway, and Longitudinal Section of the Craft

The distinctive feature of the Bars boat is its combined scheme for creating an air cushion and support, which is based on the use of low-rotation centrifugal blowers that are bent in front of the blades. This scheme provides a boat with minimal overall dimensions, simplicity of manufacture, and high reliability and operating safety. The blower rotors are suspended on the main engine, and the entire complex has been configured in a unit.

Air is fed through specially profiled skins into the air cushion and into the propulsive nozzles. A reversing device, which makes it possible to change the direction of the flow, is mounted in the nozzles. This makes the boat highly controllable at low speeds and when it is in reverse. The boat's course is controlled aerodynamically by controllers mounted in the flow of the propulsive nozzles.

The main engine (a type M-14V26 rotor carburetor engine with air cooling) has a rated capacity of 175 kW. Also suspended on the main engine besides the blowers are a 3-kW DC generator and compressor for replenishing the starting reserves. The fuel reserves amount to 270 L or 470 L with attached fuel tanks.

The passenger and freight compartment contain a pilot's chair, remote control equipment to control the boat and its mechanisms, two passenger chairs, a 5-person sofa, and a folding chair. When necessary the sofa and chair are easily disassembled, and the area freed as a result can be used to hold cargo. The compartment is heated by the engine and by a stand-alone heater. All of the glass is electrically heated.

The boat is equipped with a hoisting and transport device that makes it possible to transport the boat by helicopter or aircraft as well as to transport it within the bounds of an airdrome (Figure 2). The Bars may be transported on an external suspension of an Mi-8 helicopter.

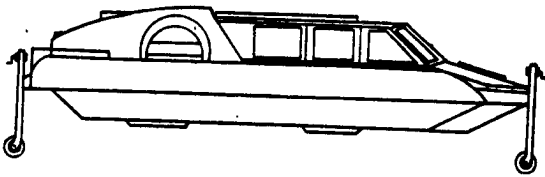

Figure 2. Acv "Bars", Prepared for Transportation

Prototype boats of the Bars type have passed comprehensive tests in the most diverse climate and route conditions. For example, the boat was subjected to trial operation in the Arkhangelsk Oblast for a year on two routes (200 and 170 km). The boat operated daily, servicing one of the two routes each day and delivered mail to 16 communications branches located on the shores of the Pinegi River. In the winter-spring and autumn-winter periods it was also operated on different routes: it crossed highways intended for automobiles; it surmounted ice reefs and piles 0.5 to 1.0 m high; it moved along loose and freshly fallen snow, frozen snow crust, and smooth and broken ice as well as ice drifts, and it operated at night. During summer the boat traveled along drifts without losing speed and along shallows and sand bars. Thus, between April 1983 and May 1984, the Bars covered 36,800 km, operated 218 days in a row, and logged 900 hours, 800 hours of which was "pure" running time. It had an average speed between stops of 45.7 km/h, a specific gasoline consumption of 1.08 kg/km (47.5 kg/h), and an operating readiness coefficient of 0.79.

The following results were obtained when the boat was tested in the central and southern regions of the country. Moving over the water, the boat operated in a mode with a full load during a head wind of up to 10 m/s and waves up to 0.5 m high. Without losing speed, it surmounted sections of dry land and reed thickets up to 1.8 m high. By accelerating, it was able to surmount 50-m sections of old dense reeds up to 2.5 m high. Its maneuverability qualities allowed it to move at a speed of about 30 km/h along a river no more than 12 m wide and whose course had turns of up to 180 degrees every 50 to 100 m along its path. The boat's maximum speed in calm water with a full load was 83 km/h.

When moving over dry land, the boat was easily able to cross viscous clay banks, swampy sections, fields with vegetation up to 80 cm high, and furrows 10 cm high and wide. By accelerating, it was able to surmount hills 4 to 5 m high with a curvature of about 15 degrees. The boat passed through ravines up to 1.5 m wide and handled smooth obstacles up to 0.8 m high.

All of these results confirmed the high efficiency of the Bars and served as a reliable foundation for working out the design components of these boats and launching them into series production. They are currently being series produced and used in different sectors of the national economy in very remote and hard-to-access regions of the country.

The appearance of the Bars air cushion boat aroused great interest on the part of representatives of different departments, especially those involved in assimilating the country's Far North and the remote regions of Siberia. The boat's substantial cost, the need to create special repair bases involving aviation specialists, the complexity of debugging the supply of aviation spare parts, and the need to use great amounts of special aviation fuel are all obstacles for some customers.

Data from comprehensive tests of the Bars and the results of a series of experiments made it possible to begin creating an air cushion boat called the Gepard that has the country's largest inexpensive gasoline engine, the EMZ-53, which has a capacity of about 90 kW at 3,200 rpm (Figure 3).

Main components and characteristics of the Gepard boat:

Length, m	7.3
Width, m	3.8
Height, m	2.8
Load-carrying capacity, kg	400
Passenger capacity, persons	5
Speed, km/h	
Maximum	77
Operating	55
Autonomy from standpoint of fuel reserve in operating mode, h	5

The boat is made of AMg5 and AMg61 aluminum alloys. Two air propellers are mounted in aerodynamic packings, with the profiling of the blades that have been selected making it possible to reduce the propeller's rotating frequency and thereby reduce aerodynamic noise and erosion. A stainless steel shield provides protection at the intake edge of the blades, which are made from special ruggedized glass-reinforced plastic. A centrifugal blower with glass-reinforced plastic profiled blades serves to form the air cushion. Cardan shafts and flat-toothed belt transmissions are used to help transfer the torque from the engine to the blower and to the air propellers. To make starting the boat easier, especially in low temperatures, the boat has been provided with the

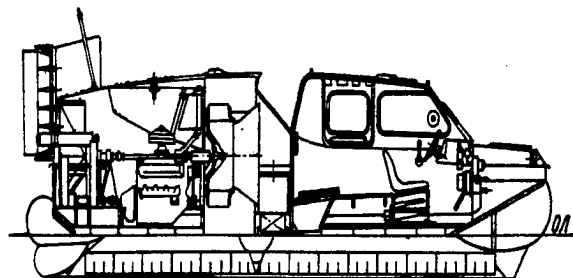

Figure 3. Boat "Gepard" and Its Longitudinal Section

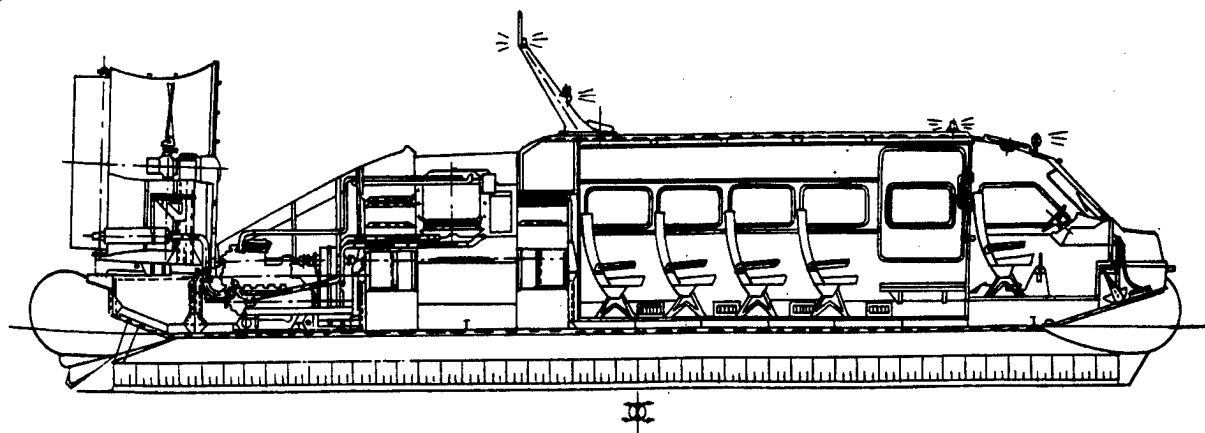

Figure 4. Boat "Puma" and Its Longitudinal Section

possibility of disconnecting the transmission from the motor. There is a heater for the coolant fluid. The vessel is controlled by vertical and horizontal aerodynamic controllers, which create the required trim and bank for reacting to sudden actions of impressed forces. The controllers are mounted on aerodynamic packings.

In view of the boat's operation during the winter, the pilot's cabin has a heat-insulating covering and is equipped with a heater that feeds heated air into the boat's lounge and onto the front windshield. Foam buoyancies, which make it possible to keep the boat afloat when any of its compartments is submerged, are located under the suspended sections.

The first prototype of the Gepard air cushion boat was built in 1981, and it completed verification tests at water reservoirs in the Moscow area. The boat's main technical characteristics were refined during the tests, and the main decisions made during its design were confirmed. A number of flaws that were later eliminated were also detected at that time. Thus, based on the results of the tests conducted during the winter on snow-covered and hummocked river and lake surfaces and on broken ice, it was necessary to increase the thickness of the boat's bottom from 1 to 1.5 mm and to replace the material used to sheath the hull with a weaker but lighter plastic material. For the very same reasons, it was also necessary to increase the thickness of the flexible skirt. Experiments were conducted to find the optimum version of the fabric for the removable elements of the flexible skirt, and its design in the stern portion was changed.

Next, after the flaws were eliminated, a set of service life tests were conducted. During the course of these tests, the boat completed about 7,500 km in all. The development of the boat's design was conditioned and the life of its main components determined on the basis of the test results. The removable elements of the flexible skirt are the components

that are most susceptible to wear. From this standpoint, operation above a water surface is most favorable, and operation over hummocks is least favorable.

Series construction of Gepard boats is currently underway. They are being purchased by rescue services, the water militia, various administrations of nature sanctuaries, postal services, lumberers, oilmen, gas works employees, power engineers, and large game establishments in Siberia. In many cases of its operation, however, the Gepard's load-carrying capacity has turned out to be inadequate. A larger-capacity and more economical air cushion boat has been required. Hence the appearance of the Puma, which has a load-carrying capacity of 1,300 kg and which is equipped with two ZMZ-53 engines (Figure 4).

The boat has been designed for class R of the RSFSR River Registry in medical, passenger, and freight and passenger versions. As a rescue boat providing emergency medical care, it is equipped with an operating table, the respective medical equipment, and oxygen tanks. All of this makes it possible to provide emergency medical care, all the way up to simple operations, directly on board. The lounge of the passenger version includes 16 aircraft chairs, and in its freight and passenger version it is equipped with 10 folding chairs. The first two versions of the Puma have already passed comprehensive tests. No more than 2 years elapsed from the beginning of its design stage to the tests of the finished air cushion boat—the prototype's design and construction phases were conducted simultaneously. After being manufactured according to the sketch, the components then proceeded to the building slip, and the sketches were issued after already being in their refined form. Thus, original design decisions were found during the course of construction, and time was saved. For example, it was possible to provide a noise level of 83 dB in the cabin, i.e., a noise level like that in a typical truck.

**Main Components and Characteristics of Puma Air Cushion Vessel (passenger version):**

Length, m	12.2
Along inflated skirt	12.2
Between perpendiculars	11.1
Width, m	
Along flexible skirt	5.2
Along impermeable hull	2.5
Height, m	
Of side in middle	0.6
Of lounge	1.75
Water displacement, t	
Light	4.04
Total	5.7
Payload, t	1.66
Passenger capacity, persons	16
Crew, persons	2
Speed, km/h	
Maximum	60
Operating	40
Autonomy, h	
Rated	5
With extra fuel	15

At operating speed, the boat can surmount slow inclines up to 5 degrees. At maximum speed, it can surmount short inclines up to 12 degrees. Moreover, because it has a hovering height of 0.6 m, it is capable of crossing obstacles up to 0.3 m high and smooth protruberances up to 0.8 m high.

Each of its two engines turns two rotors of the centrifugal ventilators that are located in the blower compartment and one lead screw in the aerodynamic ring packing. This type of scheme makes it possible to increase the boat's reliability because, even when one of the motors fails, the boat can reach its destination. The blowers feed air under the hull as well as into a ring-shaped receiver (a smooth skirt made of rubberized fabric) fastened around the hull. Air is also fed under the hull through openings in the lower part of the receiver, which creates a support that keeps the boat freely suspended. To keep the air under the hull and to protect the receiver from damage, removable elements made of rubberized fabric are fastened to the lower part. They make contact with the surface over which the boat moves. Elements that are damaged during operation are easily replaced. The reversing lead air screws are turned by the engines with the help of pulleys and flat-toothed belts. Four air controllers are mounted on the rear edge of each of the packings.

The first boat, in the medical version, passed tests in areas of the Tomsk Oblast. In winter the Puma was able to pass 400 km along hummocked ice with ice blocks up to 0.6 m high, i.e., the same height as the flexible skirt. A second boat, in the passenger version, passed tests at the water reservoirs near Moscow, and in September 1987 it passed tests in the shallow sections of the Caspian Sea, for which it completed an independent crossing from Volgograd to the test site along the Volga and the Caspian Sea. The boat's design was modified further based on the test results.

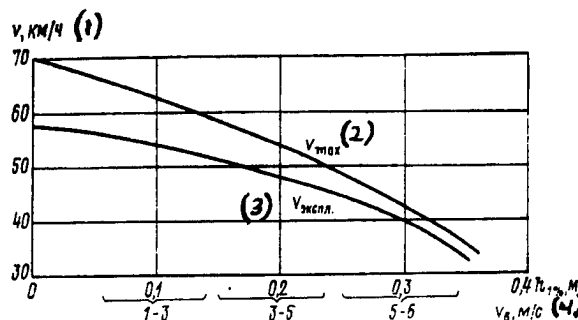

**Figure 5. Speed of the Bars Air Cushion Vehicle as a Function of Wave Height With a 1 Percent Wave Level and Wind Velocity.**

Key: 1.  $V$ , km/h 2.  $V_{max}$  3.  $V_{operating}$  4.  $V_{waves}$ , m/s

The air cushion boats examined here are termed amphibious. This does not mean, however, that they can be operated under ground conditions, in areas in which there are no roads, or along roads. They are primarily water vehicles, and they can only travel along flat, familiar, and well-tried areas. It is characteristic that during the winter amphibious air cushion boats are generally operated at engine capacities that are 20 to 30 percent less than those used in the summer and at an average operating speed that is 5 to 10 km higher. It should be emphasized that, unlike in the case of water-displacing boats, the speed of air cushion boats is significantly dependent on wind and wave conditions (Figure 5). This must be taken into account when the boats are operated, and an attempt should be made to use these boats mainly in small rivers and reservoirs.

Designers are currently faced with the task of creating less energy-intensive vessels and using diesel units. An air cushion vessel of this type with a passenger capacity of about 30 persons or a load-carrying capacity of 2.5 t is currently being designed.

COPYRIGHT: Izdatelstvo "Sudostroyeniye" 1988

22161  
93

NTIS  
ATTN: PROCESS 103  
5285 PORT ROYAL RD  
SPRINGFIELD, VA

22161

This is a U.S. Government publication. Its contents in no way represent the policies, views, or attitudes of the U.S. Government. Users of this publication may cite FBIS or JPRS provided they do so in a manner clearly identifying them as the secondary source.

Foreign Broadcast Information Service (FBIS) and Joint Publications Research Service (JPRS) publications contain political, economic, military, and sociological news, commentary, and other information, as well as scientific and technical data and reports. All information has been obtained from foreign radio and television broadcasts, news agency transmissions, newspapers, books, and periodicals. Items generally are processed from the first or best available source; it should not be inferred that they have been disseminated only in the medium, in the language, or to the area indicated. Items from foreign language sources are translated; those from English-language sources are transcribed, with personal and place names rendered in accordance with FBIS transliteration style.

Headlines, editorial reports, and material enclosed in brackets [ ] are supplied by FBIS/JPRS. Processing indicators such as [Text] or [Excerpts] in the first line of each item indicate how the information was processed from the original. Unfamiliar names rendered phonetically are enclosed in parentheses. Words or names preceded by a question mark and enclosed in parentheses were not clear from the original source but have been supplied as appropriate to the context. Other unattributed parenthetical notes within the body of an item originate with the source. Times within items are as given by the source. Passages in boldface or italics are as published.

#### SUBSCRIPTION/PROCUREMENT INFORMATION

The FBIS DAILY REPORT contains current news and information and is published Monday through Friday in eight volumes: China, East Europe, Soviet Union, East Asia, Near East & South Asia, Sub-Saharan Africa, Latin America, and West Europe. Supplements to the DAILY REPORTs may also be available periodically and will be distributed to regular DAILY REPORT subscribers. JPRS publications, which include approximately 50 regional, worldwide, and topical reports, generally contain less time-sensitive information and are published periodically.

Current DAILY REPORTs and JPRS publications are listed in *Government Reports Announcements* issued semimonthly by the National Technical Information Service (NTIS), 5285 Port Royal Road, Springfield, Virginia 22161 and the *Monthly Catalog of U.S. Government Publications* issued by the Superintendent of Documents, U.S. Government Printing Office, Washington, D.C. 20402.

The public may subscribe to either hardcover or microfiche versions of the DAILY REPORTs and JPRS publications through NTIS at the above address or by calling (703) 487-4630. Subscription rates will be

provided by NTIS upon request. Subscriptions are available outside the United States from NTIS or appointed foreign dealers. New subscribers should expect a 30-day delay in receipt of the first issue.

U.S. Government offices may obtain subscriptions to the DAILY REPORTs or JPRS publications (hardcover or microfiche) at no charge through their sponsoring organizations. For additional information or assistance, call FBIS, (202) 338-6735, or write to P.O. Box 2604, Washington, D.C. 20013. Department of Defense consumers are required to submit requests through appropriate command validation channels to DIA, RTS-2C, Washington, D.C. 20301. (Telephone: (202) 373-3771, Autovon: 243-3771.)

Back issues or single copies of the DAILY REPORTs and JPRS publications are not available. Both the DAILY REPORTs and the JPRS publications are on file for public reference at the Library of Congress and at many Federal Depository Libraries. Reference copies may also be seen at many public and university libraries throughout the United States.