

JPRS-UFM-89-003
9 MARCH 1989



**FOREIGN
BROADCAST
INFORMATION
SERVICE**

DISTRIBUTION STATEMENT A

Approved for public release;
Distribution Unlimited

JPRS Report

Soviet Union

FOREIGN MILITARY REVIEW

No 9, September 1988

19980506 134

DTIC QUALITY INSPECTED 2

REPRODUCED BY
U.S. DEPARTMENT OF COMMERCE
NATIONAL TECHNICAL
INFORMATION SERVICE
SPRINGFIELD, VA. 22161

Soviet Union

FOREIGN MILITARY REVIEW

No 9, September 1988

JPRS-UFM-89-003

CONTENTS

09 March 1989

[The following is a translation of the Russian-language monthly journal ZARUBEZHNOYE VOYENNOYE OBOZRENIYE published in Moscow by the Ministry of Defense. Refer to the table of contents for a listing of any articles not translated]

Conscientious Military Discipline—Basis of the High Combat Readiness of the Armed Forces [pp 3-6]	1
The Mediterranean in U.S. and NATO Plans [L. Nikitin; pp 7-12]	4
Joint Chiefs of Staff of U.S. Armed Forces [Yu. Omichev; pp 12-16]	8
Army Aviation of the French Ground Forces [M. Simakov, S. Blagov; pp 17-22]	13
American Ground Radio Communications Systems in the Millimeter Band [A. Skorodumov; pp 23-28] ..	17
Self-Propelled Howitzer G-6 [Ye. Viktorov; pp 29-30]	23
American F-111 Aircraft [P. Ivanov; pp 36-40]	24
Utilization of the Achievements of Oceanography for the U.S. Naval Forces [B. Bolgurtsev; pp 45-49]	27
Modernization of the TACAMO Very Low Frequency Reserve Communications System [O. Moiseyenko; pp 49-52]	31
Japanese Naval Aviation [R. Fedorovich; pp 52-59]	34
Prospective Automated Ship System of Battle Management for Great Britain's Naval Forces [V. Sereyushin; pp 59-60]	39
Military Expenditures of Key European NATO Countries in 1988 [N. Voronov, L. Borisov; pp 61-69]	40
Views on Civil Defense in the United States [I. Mysyuk; pp 70-74]	45
New English Aircraft [I. Karenin; pp 76-77]	50
Articles Not Translated from ZARUBEZHNOYE VOYENNOYE OBOZRENIYE No 9, September 1988	51
Publication Data	51

FOREIGN MILITARY REVIEW

No 9, September 1988

Conscientious Military Discipline—Basis of the High Combat Readiness of the Armed Forces *18010239a Moscow ZARUBEZHNOYE VOYENNOYE OBOZRENIYE in Russian No 9, Sep 88 (signed to press 7 Sep 88) pp 3-6*

[Article: "Conscientious Military Discipline—Basis of the High Military Readiness of the Armed Forces"]

[Text] Conscientious military discipline is one of the critical conditions for the high combat readiness of the armed forces. Without it, it is impossible to achieve victory in contemporary combat, to give the soldiers the necessary morale and combat qualities, and to attain the heights of military mastery. Soviet military discipline, being based on the political awareness of servicemen and their unreserved devotion to the Motherland and on a profound understanding of their patriotic duty, makes our army a strong and united military organism capable of performing any tasks.

At the very dawn of Soviet authority, V.I. Lenin stressed that the young Republic of the Soviets, being surrounded by capitalists, would not exist long without a strong and organized army. This appeal was primarily to the workers and peasants as well as to those who, without thought to their own sacrifices, were to defend the Soviet republic, having organized themselves through proletarian discipline. In the letter "Everything for the Struggle Against Denikin!," V.I. Lenin noted the necessity of military discipline and vigilance "carried to the highest extremes."

Soviet military discipline is one of the forms of state discipline. It, as is noted in the Disciplinary Regulations of the USSR Armed Forces, is the strict and exact observance by all military personnel of the order and rules established by Soviet laws and military regulations. It is based on each serviceman being aware of his military duty and personal responsibility for the defense of his Motherland—the Union of Soviet Socialist Republics. The demands of Soviet military discipline express the unified will of our country's multinational people aimed at the defense of the revolutionary achievements and at ensuring peaceful conditions for the building of communism. The faultless performance of this will is an obligation legalized by the Constitution of the USSR and the highest moral duty of every Soviet serviceman.

Military discipline is the ultimate basis of the combat readiness of the Soviet Armed Forces. It raises the combat moral of the army and navy, provides for order and organization as well as the high level of responsibility and performance of the soldiers, transforms them into a unified and flexible organization, and forms that

unity of strength and will that makes it possible to direct hundreds, thousands and millions of people for the performance of the established mission.

"If these masses have now established a new discipline in the Red Army," said V.I. Lenin, "not the discipline of the stick and property holder but the discipline of Soviet worker and peasant deputies, if they are now undertaking the greatest self-sacrifices, and if a new solidarity has developed among them, then this is because a new socialist discipline is arising and has arisen for the first time in the consciousness and experience of tens of millions, because the Red Army came into being" ("Poln. sobr. soch." [Complete Collection of Works], Vol 37, p 123).

Today greater demands are being put on the state of the discipline of soldiers and on the level of their conscientiousness. This is dictated by the following basic reasons.

In the first place, by the development of military affairs, by the tremendous changes in the provision of troops and naval forces with new equipment and technology, and by fundamental changes in the means of carrying on combat operations.

Secondly, by the fact that many types of modern-day weapons have become a means of collective utilization. Their successful use depends on the joint precise, coordinated and skillful actions of soldiers with different specialties. For this reason, even isolated instances of carelessness, poor performance and negligence can lead to unjustified losses and even to the nonperformance of the established mission.

Thirdly, by the increase in the intensity of military labor as a result of the growth and the increasing complexity of the technical equipment of troops and, in this connection, by the necessity of strengthening the moral and political and psychological training of personnel for contemporary combat operations.

Fourthly, by the use in a future war, if the imperialists unleash such a war, of previously unknown means of armed combat. The operations of troops (forces) will be distinguished by complexity and be accompanied by rapid changes in the situation. They will require of the soldiers unprecedented physical and moral endurance, an extreme degree of organization and preparation, quick reaction and the ability in a matter of minutes or seconds to utilize the firepower of the weapons and the possibilities of military technology to their full extent.

The nature and character of Soviet military discipline are determined by the very nature of the socialist social system, the Soviet state and its armed forces standing guard over the achievements of socialism and the interests of the working people. This is why it is perceived by service members as a realized necessity and a guarantee of the invincible might of the USSR Armed Forces.

The foundation of Soviet military discipline is the ideological conviction of the soldiers, their unreserved loyalty to the Soviet Motherland, and their profound understanding of their patriotic duty and the international tasks of our nation.

In stressing the conscious nature of discipline in the army of a socialist state, V.I. Lenin noted: "The Red Army established unprecedented firm discipline not through the stick but on the basis of the awareness, loyalty and self-sacrifice of our workers and peasants" ("Poln. sobr. soch." [Complete Collection of Works], Vol 38, p 240). And this is its fundamental difference from the discipline in the armed forces of bourgeois states.

In bourgeois armies, being the tool of the exploiting class, discipline is imposed by means of the rigorous coercion and ideological brainwashing of service members, bribing them materially, and the unleashing of the very basest instincts. The consciousness of personnel is inculcated with ideas of a submissive and heartless execution of orders and the establishment of a system that transforms the soldier and officers into "armed machines." Anticommunism and anti-Sovietism are widely used to form the necessary social atmosphere. The ideological duping of service members in this spirit is intended to rally them around the idea of the "salvation of Western democracy" from the "military threat" by the USSR and to make them more disciplined and obedient, prepared for any criminal aggressive actions in the name of the defense of the interests of imperialism.

Along with the increased moral and psychological brainwashing of the command personnel of the armed forces of the United States and the NATO member countries, they are making disciplinary measures of the administrative-penal type more rigorous and are striving to get rid of unfit persons with a critical attitude toward the policies of the leading circles. In resolving the task of strengthening discipline in bourgeois armies, they also emphasize the repression of the personality, threats, blackmail, avarice, egoism and hate.

In the Soviet Armed Forces, the support of military discipline is based on fundamentally different principles, above all on a high degree of consciousness that obliges one to bring about a persistent improvement in the ideological hardening of servicemen, to give them an in-depth understanding of the domestic and foreign policies of the CPSU and Soviet Government as well as of the noble objectives and missions of our army and the requirements of the military oath, Soviet laws and military regulations, and to teach the personnel good execution and other moral and political and combat qualities.

Good execution is taught on the ideological and moral basis of Soviet military discipline—communist consciousness. The ideas of servicemen on the principles of communist morality, the goals of the perestroika under way in the

country, the tasks facing the armed forces, and the policies of the CPSU are being shaped on the basis of the scientific Marxist-Leninist world view. All of this guarantees the development of the whole personality and the moral readiness to carry out complex combat missions.

At the present time, the personality of the serviceman is being formed under the conditions of the democratization of the military collective. The 27th CPSU Congress determined the main directions in the development of socialist democracy. But democracy is not the opposite of discipline. This is stressed convincingly in the report of CPSU Central Committee General Secretary M.S. Gorbachev at the 19th All-Union Conference of the CPSU "On the Course of the Realization of the Decisions of the 27th CPSU Congress and the Tasks in the Extension of Perestroika." In particular, it was noted in the report that democracy "is incompatible either with self-will or irresponsibility or lack of discipline." True democracy has nothing in common with permissiveness, anarchy or social demagoguery.

Is democratization admissible in the armed forces, where the whole life and activities of service members are strictly regimented? In answering this question, Arm Gen D.T. Yazov, candidate member of the CPSU Central Committee Politburo and minister of defense of the USSR, stressed: "Democratization is not only admissible in our armed forces but is an essential condition for their normal functioning and for the successful performance of the mission of defending the socialist Fatherland. It does not contradict the positions of the regulations, orders and directives that guide the armed forces and expresses the socialist nature of our army—a new type of army." Glasnost is an effective weapon in democratization. The atmosphere of glasnost contributes to the development of an active living condition for servicemen and to the affirmation in military collectives of implacability toward any signs of stagnation and instances of bad faith, poor execution and unstatutory interrelationships. Glasnost presupposes a pluralism of opinions. The necessity of taking into account the opinions of subordinates in work is provided for by our general military regulations and field manuals. It is quite natural that they do not permit criticism and discussion of orders but, at the same time, by no means do they equate to the right to issue orders with no originality and with static thinking.

Democracy in army and naval conditions is reflected, in particular, in public opinion. Its main function is to regulate relations among people, between the individual and the collective, and between the collective and the society. This also applies fully to military collectives, where public opinion makes certain demands on the conduct of soldiers and on the support of an atmosphere of disciplined behavior and strictness toward oneself and others. The strict observance of these demands helps in the performance of the sacred duty of the defenders of the Fatherland.

One of the criteria of the disciplined behavior of the serviceman and an indicator of his consciousness and understanding of his personal responsibility for the defense of the socialist Motherland is self-discipline—the ability to handle oneself and one's own actions, to demonstrate stamina and self-control, and to be able to detect one's own errors, omissions and shortcomings in time and eliminate them. Self-discipline presupposes the person's ability to put high demands on himself, to be self-critical in evaluating his own actions, and to have a profound understanding of his personal responsibility for the successful performance of the tasks being resolved by the entire group of the subunit. Among the most important moral regulators in this connection are such moral values as duty, honor, conscience, the strength of the group, authority, habits and traditions.

Self-discipline, being based on moral responsibility, puts the behavior of the individual under the control of his own conscience. It is as though the individual is being made the creator of his own actions, which does not, of course, eliminate their causal dependency but merely includes personal conscience and will in the "causal chain."

Disciplined behavior is a reliable path to exploits and the mother of victory. As the rich military experience of our armed forces shows, strong military discipline and a high degree of organization gave rise to unprecedented examples of courage, firmness and mass heroism of Soviet soldiers in battles for the Motherland.

The formation of disciplined and high-quality behavior of servicemen is not a separate or isolated process. It cannot be reduced to the sum of special measures pursuing these objectives exclusively. Only as a result of an integral influence on the soldier in the entire course of his service does a comprehensive and harmonic development of the person take place, including the formation of such an essential quality as disciplined behavior. The ideological hardening of personnel is an extremely important direction in this work.

The process of teaching disciplined behavior also includes the improvement of moral behavior. The explanation of the content and importance of communist morality to servicemen plays a leading role in this connection. In addition, the moral education of personnel is continuously influenced by party and Komsomol organizations, interpersonal ties, the strict observance of statutory interrelations, high demands by the commander and his closeness to the people, socialist competition, military order and other factors. The latter foresees a precise organization of the training process, service, life and everyday living conditions of personnel. Military order is statutory order. The establishment of order in everything—combat duty, combat training, service and the everyday life of the troops and naval forces—is to be seen as the task of tasks and the will, energy, knowledge and experience of military personnel and all servicemen should be directed to its resolution.

Very significant in the strengthening of military discipline are the regulations of the Armed Forces of the USSR, representing a code of laws for military service and the basis for the training and education of personnel. They set forth the demands of the Communist Party and Soviet Government for the support of the constant combat readiness of combined units and units as well as the basic positions on the combat activities of troops.

Everyday military labor, if it is organized in strict accordance with the requirements of the regulations, becomes a powerful factor in the formation of the disciplined behavior and high morale of servicemen. Exercises and maneuvers carried out under circumstances similar to those of combat make it possible to put personnel in conditions that demand the demonstration of stamina, firmness and mutual assistance.

The regulations reflect one of the most important positions of Soviet military science, that the main and decisive force in battle and in the achievement of victory over the enemy is the individual with a good mastery of present-day weapons and military technology, hardened morally and physically, and unreservedly loyal to the cause of communism.

High military discipline is attained through the daily strictness of commanders and chiefs toward subordinates, respect for their individual worth, constant concern for them, and the skillful combination and correct application of the means of persuasion and compulsion. The ideas of V.I. Lenin are the methodological basis here. He emphasized that compulsion was applied correctly and successfully when it was first based on persuasion.

Strong and conscientious military discipline is simultaneously a condition, means and guarantee of perestroika, of the renewal of military life. As M.V. Frunze noted, commanders and political workers are always obliged to remember three Leninist conditions that are the guarantee of strong and conscientious discipline. The first of them is the self-denial and firmness of the command and political staff, the second is the preservation of active and organic ties between commanders and political workers and the mass of the Red Army, and the third is that the correctness of the leadership of the mass of the Red Army must be seen in practice.

Of special significance in the indoctrination of conscientious discipline is the fight against harmful habits, relics of the past and above all against such an abnormal phenomenon as drunkenness. As one of the most important directions in this work, the party put forward the affirmation of sobriety as the norm in the life of the Soviet people. The CPSU Central Committee decree "On Measures to Overcome Drunkenness and Alcoholism" and the decree of the USSR Council of Ministers and ukase of the USSR Supreme Soviet Presidium "On Strengthening the Fight Against Drunkenness" received the full approval of the entire nation. Drunkenness is

completely intolerable in the armed forces and is the enemy of combat readiness and the norms of military activity. The struggle for a sober way of life and for high standards of conduct under the conditions of the army and navy is an extremely important direction in the strengthening of military discipline in units and on ships.

A large role in the resolution of the large-scale tasks of revolutionary scope in the perestroyka of all areas of our life is assigned to the raising of the disciplined nature and organization as well as the social responsibility, activeness, efficiency, initiative and independence of the Soviet people. The decisions of the 19th All-Union Party Conference and of the servicemen of the Soviet Armed Forces require this. The harmonious and coordinated action of commanders, political officers, staffs, party and Komsomol organizations and the skillful utilization of tried as well as the search for and application of new forms of ideological-political and moral military indoctrination of personnel ensure success in the resolution of the tasks in the further strengthening of military discipline and the raising of the combat readiness of subunits, units and ships.

COPYRIGHT: "Zarubezhnoye voyennoye obozreniye", 1988.

The Mediterranean in U.S. and NATO Plans
18010239b Moscow ZARUBEZHNOYE VOYENNOYE OBOZRENIYE in Russian No 9, Sep 88 (signed to press 7 Sep 88) pp 7-12

[Article by Maj Gen L. Nikitin, candidate of military sciences, under "General Problems Armed Forces" rubric: "The Mediterranean in U.S. and NATO Plans"]

[Text] An analysis of the policies and practical actions of the American administration, U.S. Defense Department and leadership of the North Atlantic bloc indicates that in recent years a large region of the Mediterranean Sea with the adjacent countries and waters of the Sea of Marmara and southern part of the Black Sea is becoming an area of particular militaristic activity and aggressive strivings of imperialist circles. Foreign specialists explain this situation through a number of political, economic, military strategic and other factors.

Nineteen countries with different political systems are located in the coastal region of the Mediterranean. Among them, Turkey, Italy, France, Spain and Greece are NATO members and Israel, Egypt, Morocco and Tunisia have close comprehensive ties with the United States and Western Europe. The situation in the region is characterized by a complex interweaving of major military and political problems. They include the Israel-Arab conflict, the urgency of which has recently become especially obvious as a result of the mass actions of the Palestinian people in the territories occupied by Israel;

the continuing conflicts between Turkey and Greece; and the complex situation in Cyprus, where a group of Turkish troops numbering more than 27,000 is permanently stationed.

In connection with the reduction of the direct shipments of oil from the Persian Gulf countries as a result of the Iran-Iraq war, there has been an increase in the economic importance of several coastal states of North Africa and the Middle East directly or indirectly supplying Western Europe with petroleum products and other materials. We are noting an increase in the volume of sea shipments in the Mediterranean Sea and in the intensity of the use of many ports, the Suez Canal and straits.

The Mediterranean region with its large number of ports and naval and air bases located not so far from the southern borders of the Soviet Union and other socialist countries is seen in the military plans of the United States and NATO as an important strategic staging area in the event of the unleashing of a war for operations from the southwest and south. This is indicated, in particular, by the many exercises of the armed forces of the North Atlantic bloc. In recent years, we have clearly been seeing the militaristic course taken by imperialist circles for the achievement of military superiority over the USSR and its allies in the Southern European Sector, which the NATO leadership considers second in importance in the European theater of war.

Within the boundaries of the Southern European Sector is a major grouping of bloc armed forces numbering, even in peacetime, according to the foreign press, more than 1.2 million men, about 6,000 tanks, and up to 1,200 combat aircraft (no fewer than 300 of which are American). The armed forces of the NATO countries have different nuclear delivery systems, including American. The grouping of air forces that includes tactical and deck aircraft is considered sufficiently strong in the region. The unified NATO air forces in this sector include aviation units from the United States, Italy, Turkey and Greece brought together in the 5th and 6th Integrated Tactical Air Commands.

The naval strike forces, the core of which are the warships of the U.S. 6th Fleet, are the most combat-ready and battleworthy operational formation of the naval forces in the sector. At different times, it has included 20 to 25 and sometimes more warships (including 1 or 2 multipurpose aircraft carriers), each of which can have more than 80 combat aircraft and helicopters on board, including as many as 40 carriers of nuclear weapons. American missile-armed nuclear submarines are on combat patrol in the Mediterranean Sea. In the event of the threat of war or in wartime, large strategic formations of NATO naval forces are put together. They include ships of the United States, Italy, Great Britain and, under certain conditions, France that are not intended for use in NATO naval strike forces as well as ships of the Turkish and Greek naval forces.

Altogether the combined NATO naval forces in this sector can include 300 or more ships of the basic classes and more than 400 aircraft and helicopters.

The U.S. and NATO commands make active use of the territories (water areas) of the Mediterranean in the Southern European Sector for organizing many bloc and national exercises of staffs, troops and naval forces and their number is increasing continually. The largest of them are the annual exercises of the troops and naval forces "Display Determination," "Dragon Hammer," "Dog Fish" and "Dense Crop."

In the course of the NATO exercise "Display Determination," according to reports in the foreign press, they rehearse the tasks for the strategic deployment of troops and forces and the carrying out of the first operations in the initial period of the war. Territorially it encompasses practically the entire southern flank of the bloc and the waters of the Mediterranean Sea. Participating in it are the commands, staffs and units of the ground forces, tactical aviation, ships and marines of a number of countries in the sector as well as the United States and Great Britain. As a rule, an exercise of this type ends with an amphibious landing operation in one of the regions of Turkey. In "Display Determination," 16-17,000 men take part, including personnel of American subunits, more than 100 warships of different classes and about 300 combat aircraft.

Questions involving the joint utilization of different forces of the combined NATO naval forces for engaging surface ships and submarines in the Mediterranean Sea are rehearsed in the annual exercise "Dog Fish." The ships and aircraft of the naval forces of the United States, Great Britain, Italy and Turkey participate in it. In recent years, they have regularly carried out exercises of the ships of the 6th Fleet in the Mediterranean basin.

The large-scale NATO maneuvers with the participation of the U.S. armed forces in this region are alarming world public opinion, above all among the population of the Mediterranean coastal countries. The goal of such maneuvers is not only the improvement of the operational and combat training of staffs, troops and naval forces but also the open demonstration of military power and the exercising of pressure on progressive regimes unsuitable to imperialist forces. Events that took place in April 1986, when aggression was perpetrated against Libya, may serve as examples. During this period, under the pretense of air exercises in Europe and the secret redeployment of the carrier-borne and amphibious groups of the U.S. 6th Fleet, the conditions were established for the surprise strike by American aircraft against Libyan civilian and military facilities in Tripoli and Benghazi.

In recent years, the units and subunits of the naval and air forces of Morocco, Israel and Egypt have more and more often been involved in a series of exercises carried out by the American military command in the Mediterranean region.

Thus, in accordance with an existing American-Moroccan agreement, they carry out joint military exercises on a regular basis with the participation of U.S. tactical aircraft, military transport aircraft of the U.S. Air Force Command in the European Zone, special subunits and ships of the 6th Fleet. In the exercises, they work out questions in the transit redeployment of subunits of the "rapid deployment force" to the Near and Middle East through the territory of Morocco and the utilization of Moroccan military facilities and bases in their interests.

Joint American-Israeli exercises in the eastern Mediterranean have become a tradition. In the exercise of the naval forces of both countries that took place in this region in December 1987 with the use of combat aircraft, they rehearsed the tasks in the gaining of supremacy at sea, in the defense of Israeli naval bases and in the organization of the engagement of enemy ships. According to the press, five warships from the United States were involved in the exercise, including a nuclear submarine, as were F-16 aircraft stationed at the Indzhirlik [transliteration] (Turkey) air base. From the Israeli side, there were missile patrol boats, aircraft of tactical and base patrol aviation, and aircraft of the AWACS and E-2C "Hawkeye" command. The overall tendency of the exercise was anti-Arab. According to the command assessment it helped to raise the military proficiency of the naval staffs and subunits and to develop the military cooperation of both sides.

In Egyptian territory, under an agreement with the country's leadership, the joint American-Egyptian exercises "Bright Star," "Sea Wind," "Iron Cobra" and "Elf Sentry" are carried out on a planning basis. The largest of them was the exercise "Bright Star 87," which took place in Egypt, Jordan and Somalia. Its active phase was conducted in Egyptian territory and in coastal waters. Participating on the American side were operational groups of the staffs of the joint central command, the air force, individual units of the "rapid deployment force," subunits of the marines, combat and transport aircraft, and ships of the 6th Fleet; from the Egyptian Armed Forces came units of ground forces and subunits of the naval forces, combat and transport aviation. The two sides employed about 45,000 men, more than 450 aircraft and helicopters, and up to 20 warships, including 2 American aircraft carriers.

In the course of the exercise "Bright Star 87," they rehearsed questions in the strategic redeployment of the forces and systems of the joint central command to regions of possible conflicts (as applied to the territories of Egypt and Jordan) and in the use of units of the "rapid deployment force" and armed forces of countries friendly to the United States in combat. In the active phase of the exercise, an amphibious landing was carried out in Egypt and adjacent waters and they worked through questions concerning the antiaircraft forces, air support and logistic and technical support. It is significant that they also examined a version of the utilization of B-52 strategic bombers in combat. The organization

and execution of this large-scale exercise with the participation of American armed forces is still more evidence of Washington's striving to expand its military presence in this region in accordance with the policy of "neoglobalism" being pursued by the United States.

Utilizing the infrastructure established in the Mediterranean, the command of the U.S. naval forces is striving to extend its activities to adjacent regions. American warships have begun to enter the Black Sea regularly, thereby creating dangerous situations along the sea borders of the USSR. In February 1988, as everyone knows, two ships—the guided-missile cruiser "Yorktown" and the destroyer "Caron" intentionally violated the national border of the USSR in the area of the Crimean Peninsula. They did not react to a warning by the Soviet border service, created a dangerous situation in the region of the maneuver and only after active measures undertaken by two Soviet ships did they leave our country's territorial waters. Such provocative actions of the U.S. naval forces were clearly aimed at undermining the process of normalizing Soviet-American relations and at establishing the preconditions for an aggravation of the situation in the region.

The 1980's are characterized by the further development of the infrastructure of the Mediterranean zone in the interests of national armed forces as well as NATO. Being interested in the utilization of elements of the infrastructure for its own armed forces, the United States is actively assisting its partners in its improvement. At the present time, according to information in the foreign press, more than 60 military airfields, up to 50 naval bases, base facilities for naval forces and ports, and a large number of depots for various purposes are being employed in the interests of NATO. As an active member of NATO, the United States, in expanding its military presence in the Mediterranean, is actively utilizing many military facilities there, including airfields and air bases in Spain (Torrejon, Rota), Italy (Aviano), Turkey (Indzhirlik [transliteration], Konja), Greece (Hellenikon), Cyprus (Akrotiri), Morocco (Sidi-Sliman, Er-Rashidiya, Rabat-Sale) and Egypt (West Cairo and others). Ships of the 6th Fleet regularly visit naval bases and base facilities in Spain (Palma), Italy (Naples, Gaeta, La Maddalena), Morocco (Casablanca), Turkey (Geldzhyuk [transliteration] and Istanbul) and Israel (Haifa). In the interests of its armed forces, the Pentagon continuously uses more than 30 military facilities of various purposes in Turkey and up to 15 in Egypt, Israel and Cyprus. An agreement has also been reached with the Turkish Government on the maintenance of American ships at several bases in the country.

At the same time, it is becoming more and more difficult for the leadership of the United States to gain access to military facilities in foreign territories. As everyone knows, on the agenda is the question of the elimination of the American air base at Torrejon in Spain, the public

of Greece and Cyprus is coming out against the military presence of the United States, and difficulties arose in the discussion of the problem of the leasing of military facilities in Turkey.

But the activities of the United States in the Mediterranean are not limited merely to a military presence, participation in NATO exercises, and the development of an infrastructure for military purposes. It is multifaceted and also aimed at drawing the countries of the region into the orbit of its imperialist course through the expansion of multilateral ties with them. In the development of military and political cooperation in the region, Washington is paying particular attention to such countries as Israel, Egypt, Morocco, Tunisia and, among its NATO partners, Turkey, Italy and Greece.

Israel is a stable and dependable ally of the United States in the region. Cooperation between the two countries is developing in political, military, economic and scientific areas. In 1987, Washington gave Israel the status of "U.S. ally outside NATO," which gives Tel Aviv practically the same possibilities as the participants in this alliance in the utilization of American funds appropriated for scientific research, above all in the military area. American military aid to Israel increases every year. In addition to deliveries of up-to-date arms, the United States is helping it in the modernization of military bases and radio and electronic reconnaissance centers and in the improvement of arms models. By the end of 1990, according to press reports, Tel Aviv is supposed to receive large lots of F-15 and F-16 aircraft, M60A3 tanks, attack helicopters and other American equipment under favorable terms. For its part, Israel is offering its own territory, above all naval bases, for the unhindered use by the U.S. Armed Forces. As was noted above, the Israeli naval forces participate in joint exercises with the Americans in the eastern Mediterranean. The military and political American-Israeli alliance is tending toward further strengthening.

Washington is paying more and more attention to Egypt, which occupies an important strategic position in the eastern Mediterranean. In recent years, there has been an active development of U.S. political, economic and military ties with this country. The previously signed separate Camp David agreements and the "peace" treaty between Egypt and Israel paved the way for these ties. According to the foreign press, the total volume of American aid to Egypt in the period 1979 through 1987 (above all for military purposes) amounted to about \$8.5 billion, part of which was granted gratuitously. In accordance with the current five-year plan (1987-1991), the annual American military aid to Egypt is estimated at \$1.3 billion. It is being spent for the provision of up-to-date arms, the development of an anti-aircraft system and infrastructure as well as a national military industry, and joint military exercises. The Egyptian Armed Forces are receiving from the United States M60A3 tanks, M113A2 armored personnel carriers, "Improved Hawk" anti-aircraft missile systems, and F-16

combat aircraft. As payment for this aid—the possible offering of military bases to the “rapid deployment force” under “extraordinary” conditions, participation in joint exercises of armed forces and cooperation in the realization of U.S. policy in the Middle East.

The important position of Turkey on the southern flank of NATO near the borders of the USSR and other Warsaw Pact countries as well as its active membership in NATO and dependence upon American aid establish the preconditions for the further strengthening of U.S. ties with this country. Washington views Turkey not only as a political and military ally in the region but also as a kind of binding link between the West and the Moslem countries. In March 1987, the Reagan administration was able to achieve an extension of the bilateral agreement with Turkey “On Cooperation in the Area of Defense and Economics” until 1990, in accordance with which the United States was given the right to increase to as many as 48 the number of aircraft carrying nuclear weapons based in its territory and, in the interests of its own armed forces, to modernize several military facilities used independently or jointly. They also signed agreements providing for the redeployment of a large number of tactical aircraft and combined units of ground forces of the U.S. Armed Forces to Turkey during a period of threat or wartime. The Americans are providing active assistance in the development of the Turkish military infrastructure, including in the development of a network of airfields and the establishment of an up-to-date military-industrial base.

The utilization of facilities in the country's territory in the interests of NATO and the United States and also the carrying out of exercises there with the participation of units and subunits of the American armed forces have been put on a permanent contractual basis. Annual American military aid to Turkey is increasing. According to the foreign press, it is estimated to be about \$600 million in 1988. The Turkish Army is receiving tanks, artillery guns of different calibers, aviation and other equipment from the United States. It was reported in the press that the Pentagon is continuing to seek the agreement of the Turkish Government on the strengthening of its military presence in the country, including the possible stationing of nuclear missile forces.

In viewing the territory of North Africa as a convenient staging area for military actions on the southern flank of NATO and the strategic redeployment of the “rapid deployment force,” the United States is also assigning an important role to the development of relations with Morocco and Tunisia. The results of the visit of Secretary of Defense F. Carlucci to Rabat in 1988 confirmed this. In the course of this visit, they examined the questions of military cooperation and the granting of American aid. The United States provides Morocco various types of arms, including M48A5 tanks, artillery and mortar systems, antitank and antiaircraft guns. From 1983 through 1987, according to the Western

press, financial aid to Rabat exceeded \$700 million, of which \$290 million was expended for the procurement of arms and combat equipment.

The American administration has recently been expanding its various military and political activities in the Mediterranean region with the purpose of consolidating regimes friendly to the United States and strengthening its imperialist positions and it has been assisting in the realization of NATO plans. Much effort is going into the resolution of regional problems and disputed matters between states “in the American way.” It was precisely for these purposes that trips were made to the countries of the region in 1988 by such responsible persons in the American administration as Secretary of State G. Shultz, Secretary of Defense F. Carlucci and Undersecretary of State R. Murphy. American experts take an active part in the work of all NATO organizations that involve the strengthening of the political and military structure in this region.

The United States is actively trying to put through its new version of the plan for a Middle East settlement known as the “Shultz Plan.” It expresses its agreement to convene an international conference on the Middle East with the participation of the five permanent members of the UN Security Council and all sides interested in the resolution of the conflict. But this conference, as conceived by the authors of the plan, is not to have the right of a deciding vote but will be an advisory body. As before, it is thought that the main questions in the settlement should be examined in the course of direct bilateral Arab-Israeli negotiations and it is proposed that the Palestinians (including representatives of the PLO) be included in a unified Jordanian-Palestinian delegation. The U.S. plan does not provide for the establishment of an independent Palestinian state but again the intention is to grant the Palestinians limited autonomy. The Palestinian people and many Arab countries have a negative attitude toward Washington's new initiatives that were actually prepared in the spirit of the familiar Camp David agreements.

The United States is making a great effort to eliminate the disagreements between Greece and Turkey, to settle the Cyprus problem and to resolve the crisis in Lebanon taking into account the interests of NATO. Overall the political as well as the military activities of the American administration are aimed at strengthening U.S. positions in the region, at undermining the influence of the USSR and other socialist countries here, and at localizing the actions of progressive forces.

In this way, the Mediterranean is one of the most explosive regions in the world and a difficult bundle of contradictory interests full of huge arsenals of arms and military equipment and is characterized by a high concentration of U.S. and NATO armed forces. The Soviet Union always has come out and is coming out with initiatives for reducing military potentials in the Mediterranean region. Of extreme importance today are the

peace initiatives put forward by Comrade M.S. Gorbachev, general secretary of the CPSU Central Committee in the course of his visit to Yugoslavia in March 1988. Their essence boils down to the following.

In affirming its willingness to withdraw the navies of the USSR and United States from the Mediterranean, the Soviet side has proposed as a first step to freeze as early as 1 July 1988 the number of ships and the potential of both sides' naval forces here and then to set limits for them. Even before agreement on confidence-building measures in the spirit of the Stockholm agreements, the Soviet Union and United States could inform each other and all Mediterranean countries on the redeployment of warships and on military exercises in advance and invite observers to them. M.S. Gorbachev said that our country will give full support to the working out of principles and methods for guaranteeing the security of lanes of intensive navigation, especially in international straits, by the Mediterranean countries and all other interested states.

The adoption of the peace initiatives of the USSR and other socialist countries could serve to strengthen trust, security and peace in such an important region as the Mediterranean.

COPYRIGHT: "Zarubezhnoye voyennoye obozreniye", 1988.

Joint Chiefs of Staff of U.S. Armed Forces
18010239c Moscow ZARUBEZHNOYE VOYENNOYE OBOZRENIYE in Russian No 9, Sep 88 (signed to press 7 Sep 88) pp 12-16

[Article by Maj Gen Yu. Omichev: "Joint Chiefs of Staff of U.S. Armed Forces"]

[Text] In emphasizing the use of force in international affairs, the military political leadership of the United States has created and is maintaining the most powerful and technically best equipped armed forces among the armies of the capitalist countries, numbering more than 3.3 million service members and more than 1.1 million civilian employees. They are stationed not only in the territory of the United States but, in accordance with the strategic concept of "forward basing," also in practically all regions of the globe: in Europe, in the Near, Middle and Far East, in the Atlantic, Pacific and Indian oceans, and in Central and South America. Almost 1,500 military bases and facilities are used to support them in foreign territories.

Two organizational structures—administrative and operational—have been established in the U.S. Armed Forces in the interests of managing the forces both in peacetime and in wartime, of organizing their technical equipment, general support and operational and combat training, and of acquiring personnel and maintaining them at a high level of combat readiness for deployment and utilization in different regions of the world and in conflicts of any nature and magnitude.

In accordance with the administrative organization, under which the armed forces are divided into ground forces, air forces and naval forces, they are carrying out their development, acquisition of personnel, training of cadres, provision with weapons and combat equipment, logistic and technical support, and military research and studies.

In accordance with the operational organization, under which all personnel and equipment are combined into large strategic formations and commands, specific groupings of armed forces are trained for the event of war and plans are developed for carrying out strategic operations in theaters of war. Proceeding from the adopted military strategy, the existing military-political situation and possible changes in it, the groupings of forces are controlled in wartime and versions of the use of large strategic formations, combined units and units are worked out in peacetime in the course of command and staff and field exercises.

One of the basic links in the system of the operational organization of the U.S. Armed Forces is the Joint Chiefs of Staff (JCS), a consultative and executive body providing for the actions of the president (commander in chief) and secretary of defense in the command and control of the armed forces in peacetime as well as wartime.

The term "Joint Chiefs of Staff" first appeared in the American military press in February 1942, when a meeting of the chiefs of staff of the service branches was convened to organize the joint leadership of military actions during World War II. The position on the JCS was officially set forth in a law on national security (1947). In accordance with this law, the chiefs of staff of the army, air force and naval forces were brought into the JCS with the task of coordinating plans and developing a military strategy. A combined staff of 100 officers representing all branches of the armed forces was established for the execution of their work.

In subsequent years, the structure and functions of the JCS were continually changed. Thus, in 1949, the U.S. Congress affirmed the position of chairman of the JCS with no right to vote. Beginning in 1952, they began to invite the commander of the marines to meetings of the JCS with the right to vote on questions dealing with the marines. In accordance with addenda to the law passed in 1953, the JCS becomes more a planning and consultative body and loses its right of collective control of joint commands. As early as 1958, however, it received full powers for the operational control of joint commands and members of the JCS were permitted to delegate the performance of their duties to deputies so that they could devote more time to work in the JCS. There was a substantial increase in the power of the chairman of the JCS, who was given the right to vote and equal rights with other members in resolving planning questions. The size of the combined staff was increased to 400 officers. In 1978, the commander of the marines became a permanent member.

The JCS existed in the indicated form until 1986 but the work to improve its activities continued: numerous boards were established to study the structure and tasks of the JCS and the powers of its members and various recommendations were formulated for the reorganization of the JCS. The following basic reasons for the appearance of numerous projects to improve the activities of the JCS were presented in the Western press:

—The necessity of increasing the authority of the chairman of the JCS.

—The activities of the members of the JCS who are likewise chiefs of staff of the service branches depend to a substantial extent on the situation in their branches. In examining problems common to the armed forces, therefore, they proceeded primarily from the interests of their own troops (forces), which led to rivalry and a reduced effectiveness of the proposed measures and efficiency of their application and hindered the rational planning and conduct of combat operations through the joint efforts of all branches of the armed forces. This was seen especially graphically in the course of the attempt to free the American hostages in Tehran in 1980 and in the invasion of Grenada in 1983.

—The JCS had practically no part in the process of formulating the Defense Department budget, which was also seen in the inadequate consideration of the interests of the armed forces as a whole and of the combined commands in particular and in duplication in the development and adoption of new types of weapons and combat equipment. This, in turn, led to an increase in the expenditure of funds.

Critical comments against the JCS were considered in the law on the reorganization of the Defense Department signed by the President of the United States on 1 October 1986. Under this law, the JCS includes (see schematic) a chairman, his deputy, the chiefs of staff of the army, air force and navy and the commander of the marines. The chairman is the chief military adviser to the president of the United States, the National Security Council and the secretary of defense. Other members of the JCS are military advisers to the president, National Security Council and the secretary of defense in their areas.

The chairman of the JCS is appointed by the president on the advice and consent of the Senate from among the generals (admirals) of the regular armed forces (deputy chairman of the JCS, chief of staff of the service branch, commander of the marines, commander in chief of the combined or special command) for a period of 2 years, which can be extended for two more 2-year periods. He is the highest military officer in the armed forces but, at the same time, is not considered the superior of the JCS members from the service branches.

The chairman organizes the regular meetings of the JCS, determines their agenda, decides on the inclusion of matters for discussion proposed by other members, assists them in carrying out their duties, especially in the resolution of disputed and urgent questions, and determines the schedule for the making of decisions on problems under consideration by the JCS. His functional duties include:

—assisting the president and secretary of defense in the command and control of the armed forces;

—leadership of the formulation of current and long-range plans proceeding from the resources allocated by the secretary of defense, comprehensive plans for logistic and technical support and strategic redeployment in the interests of their execution, and the formulation of recommendations for the distribution of duties among the service branches;

—leadership of the formulation and specification of plans for actions under the conditions of an extraordinary situation in accordance with the directives of the president and secretary of defense as well as the requirements of logistic and technical support and the redeployment of troops and ordnance for the purpose of their execution and formulation of recommendations for the distribution of duties among the chiefs of staff of the service branches;

—report to the secretary of defense on the most significant shortcomings in the armed forces as revealed in the course of the elaboration or specification of strategic plans and on the assessment of their influence on the performance of the tasks facing the armed forces and the achievement of national security objectives with recommendations on the elimination of these shortcomings;

—consultation of the secretary of defense on questions involving the relationship between the basic programs for the development of the service branches and the positions of the strategic plans;

—giving of recommendations to the military political leadership on the inclusion in the draft military budget of funds necessary for the provision of the activities of combined and special commands, on draft budgets and programs for the development of the service branches for the next 2 fiscal years, and on their conformity to the requirements of the secretary of defense, planned resources and needs of the troops (forces) as a whole;

—formulation in cooperation with the commanders in chief of combined and special commands and putting into effect of a unified system for the evaluation of the readiness of commands to perform their assigned tasks;

—evaluation of the needs of the armed forces in the preparation of programs for Defense Department procurements;

Basic Organization Chart of the Joint Chiefs of Staff of the U.S. Armed Forces

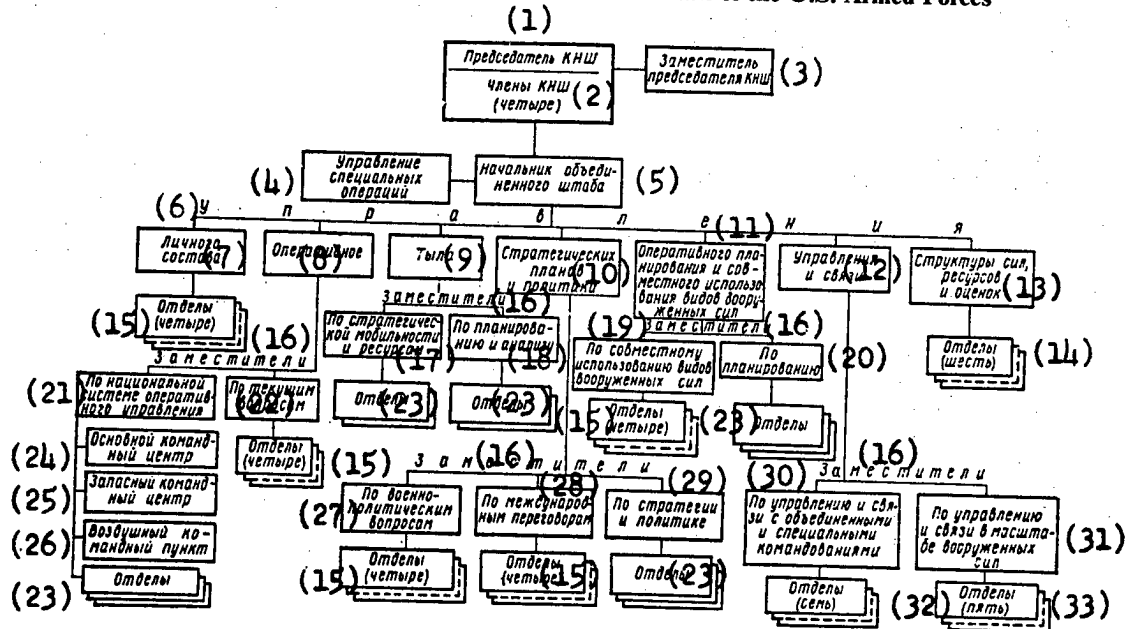

- Key:
1. Chairman of the JCS
 2. Members of the JCS (four)
 3. Deputy chairman of the JCS
 4. Special operations directorate
 5. Chief of the joint staff
 6. Directorates
 7. Personnel
 8. Operational
 9. Rear services
 10. Strategic plans and policy
 11. Operational planning and joint utilization of service branches
 12. Administration and communications
 13. Structure of forces, resources and evaluations
 14. Sections (six)
 15. Sections (four)
 16. Deputies
 17. For strategic mobility and resources
 18. For planning and analysis
 19. For joint utilization of service branches
 20. For planning
 21. For the national system of operational command and control
 22. For day-to-day matters
 23. Sections
 24. Primary command headquarters
 25. Reserve command headquarters
 26. Airborne command post
 27. For military political questions
 28. For international negotiations
 29. For strategy and policy
 30. For administration and communications with combined and special commands
 31. For administration and communications on the scale of the armed forces
 32. Sections (seven)
 33. Sections (five)

—elaboration and adjustment of military strategy and concepts for the utilization of ground forces, air forces and naval forces as well as armed forces as a whole;

—formulation of the principles for the organization of the joint operational and combat training of the service branches and instructions on the preparation of large-scale exercises of troops (forces) and on their leadership;

—organization of the representation of the Pentagon in the military-staff committee of the United Nations and other international military organizations;

—presentation of a report to the secretary of defense no fewer than three times a year with recommendations on the specification of the role, function and missions of the service branches in connection with possible changes in the nature of the threat "to the national interests of the United States," the appearance of new technologies that may be used effectively in military practice, and other factors. This report is supposed to include recommended changes that it is expedient to introduce into the appropriate legislative acts, directives, regulations and other documents.

At the decision of the president of the United States, the chairman of the JCS (his deputy in his absence) is permitted to be present at meetings of the National Security Council as a chief military adviser.

The president may also decide to make the link between him (secretary of defense) and the commanders in chief of combined and special commands be through the chairman of the JCS, which is actually done in everyday life. In addition, the president has the right to assign the chairman of the JCS duties to assist him and the secretary of defense in the course of the leadership of the armed forces.

The secretary of defense may entrust the chairman of the JCS with the control of the activities of combined and special commands without granting him any command powers and he may also assign him duties in representing and defending the interests of the commanders in chief of combined and special commands, especially in resolving operational questions and providing for their needs.

The deputy chairman of the JCS is appointed by the president on the advice and consent of the Senate from among the generals or admirals of the regular armed forces having the experience of working in combined staffs. It is considered that the chairman of the JCS and his deputy cannot belong to one and the same service branch. The term of the deputy's powers and the manner of its extension is exactly the same as in the case of the chairman.

The deputy performs the functions of the chairman of the JCS if this post is not occupied as well as in the event that the chairman is not able to perform his duties for

any reasons. In the event of the absence of the chairman and his deputy, the president appoints one of the members of the JCS for the interim performance of the duties of the former.

The deputy chairman of the JCS has the right to be present without the right to vote at all meetings of the JCS but he does have the right to vote in the event that he is performing the duties of the chairman of the JCS. He is the second military officer in seniority but is not the superior officer either of the members of the JCS or of the service branches.

The members of the JCS have responsibility for the service branches that they represent and participate in the formulation of strategic plans for their utilization and in the operational leadership of the troops (forces).

The members of the JCS have the right to give the chairman their ideas (recommendations) that may supplement or contradict the opinion of the chairman of the JCS. In this event, he is obligated to include this in his report to the president, National Security Council or secretary of defense. At the request of the president, National Security Council or secretary of defense, the members of the JCS can be heard personally or collectively on specific issues.

Under the new law, the combined staff of the JCS is the working body of the committee and primarily intended to provide for the activities of the chairman, his deputy and the members of the JCS.

For work in the combined staff, the chairman of the JCS selects officers (an approximately equal number from the ground forces, air force and naval forces) from among the candidates presented by the secretaries of the service branches, who should be the service members best-trained for such work. After consultation with other members, the chairman of the JCS selects the candidate for the position of chief of the combined staff, whose confirmation requires the approval of the secretary of defense.

The secretary of defense guarantees the organizational and operational independence of the combined staff, which is essential for the realization of the unified strategic leadership of the armed forces and their effective utilization in the combined and special commands. This body, however, is not a general staff and has no authority in the operational command and control of the armed forces.

The time of the stay of the permanently assigned officers and generals (admirals) and of those attached to the combined staff is not supposed to exceed 4 years. This period can be extended for some officers and generals (admirals) with the approval of the secretary of defense. A second assignment to the combined staff or attachment to it is permitted only after 2 years at the earliest.

The combined staff includes seven directorates: personnel; operational; rear services; strategic plans and policy; operational planning and joint utilization of service branches; administration and communications; and structure of forces, resources and evaluations. Its total number of personnel (permanently assigned personnel, attached service members and civilian employees) is not supposed to exceed 1,627.

The mission of the combined staff includes the preparation of materials for JCS meetings in accordance with the instructions of the chairman of the JCS or his deputy and the formulation and specification of mobilization, strategic and operational plans for the utilization of armed forces as well as for their logistic support.

The JCS and the combined staff represent the main link in the integral system of strategic planning serving to determine the directions for the development, strength, missions and possible means of utilization of the armed forces taking into account the predicted political and developing military strategic situation in the world. The integral system of strategic planning, in turn, is the basic instrument with the help of which the JCS performs its functions in strategic planning.

The order and procedure regulating the work of the integral system of strategic planning are established by a memorandum of the JCS. In it are set forth the nature and brief content of the seven documents that have been made the basis of the integral system of strategic planning and the responsibility for their preparation and issuance is determined. The basic planning documents cover a 20-year period, which is subdivided into three time segments: 2 years (taking into account the current year) as short, then 8 years as intermediate and 10 years as long periods of planning. They are elaborated by the combined staff of the JCS and intelligence directorate of the Defense Department, which in this case appears as one of its directorates.

These documents are described below.

The document in which a comprehensive intelligence assessment is made in the interests of planning is prepared annually in the intelligence directorate of the Defense Department and contains detailed analytical data on the near term. Primary attention is concentrated on the analysis of possible situations and versions of the development of the circumstances in different regions of the globe that might affect the "security interests of the United States" in the short and intermediate periods. It serves as the starting point for the formulation of other planning documents of the JCS.

The intelligence priorities for strategic planning are also prepared annually by the intelligence directorate of the Defense Department. In this document, they determine the most significant categories of current and long-range tasks facing military intelligence as well as the priorities in their resolution.

A comprehensive long-term strategic assessment is formulated every 4 years with changes and additions made every 2 years. The document examines versions of the development of the situation in the world as a whole and in its specific regions and proposes possible actions to guarantee the "interests of the United States." It is the basis for the determination and specification of the structure of the armed forces as well as of plans and programs for their development in the near and intermediate term.

Generalized proposals on strategic planning are prepared annually and contain recommendations to the president, National Security Council and secretary of defense on questions in the development of the armed forces and the formulation of military strategy that are essential for the achievement of the "national security objectives of the United States," that is, proceeding from a comprehensive military assessment of the threat to "American interests."

A joint memorandum on the assessment of the programs is drawn up annually for the intermediate term. It assesses questions of the adequacy of the planned strength of the armed forces, their possibilities and the degree of risk associated with them.

A joint memorandum on the provision of military aid is prepared annually for the intermediate period. It sets forth the programs for military aid to other states scheduled for financing and also points out the needs of the Defense Department for personnel and civilian employees to carry out these programs.

A joint plan for strategic capabilities is formulated annually for the next year. It contains strategic concepts for the utilization of the armed forces on a global scale and in the main regions of the world that essentially correspond to the zones of responsibility of the combined commands in the "interests of the achievement of the national security objectives and the resolution of the military missions flowing from them" and also an evaluation of available forces and resources. It consists of two parts—"Concepts, Missions and Planning Instructions" and "Forces and Resources"—and a number of proposals evaluating the capabilities of the armed forces and formulates instructions on the planning of reconnaissance, logistic and technical support and the use of nuclear weapons and on other questions.

The documents of the integral system of strategic planning enumerated above serve as a guide and basis for the elaboration and financing of programs for the development of the armed forces and operational plans for their application.

The operational control of the armed forces in the JCS is implemented through the primary and reserve command headquarters and the airborne command post directly under the combined staff. They make up a national system for operational control, which is the core of the

global system of operational control. The latter gives the higher military political leadership of the United States the possibility of centralized control of the armed forces in peacetime as well as in wartime.

The primary command headquarters of the JCS, intended for the operational control of the armed forces in peacetime, is located in the underground part of the Pentagon and has no protection against nuclear weapons. The headquarters functions around the clock, which is done through several duty shifts including specialists from the combined staff and intelligence directorate of the Defense Department. Its equipment makes it possible to carry out the automated collection, processing and display of data on the current situation and reference information on individual questions of greatest importance.

The reserve command headquarters of the JCS is located to the northwest of Washington (state of Maryland) in the foothills of the Blue Ridge Mountains. According to American press reports, it is under ground and has a rather strong defense against nuclear weapons and autonomous life-support systems. In wartime, the reserve command headquarters can be used by the president of the United States as a control center.

The airborne command post of the JCS is intended for the command and control of the armed forces in the event that the ground control agencies are disabled. It has been assigned the task of being ready at all times to take on board the president of the United States, the secretary of defense or the chairman of the JCS. Four E-4 aircraft (based on the Boeing 747) have been equipped for the airborne command post. They are stationed at Offutt Air Force Base (state of Nebraska). Three operational groups (each with up to 30 people) have been established to provide for alert duty around the clock during peacetime.

Overall, according to numerous analyses appearing in the American press after the adoption of the law on the reorganization of the Defense Department (1986), the current Joint Chiefs of Staff has undergone substantial changes. It is stressed above all that the chairman of the JCS has become the chief military adviser to the president, National Security Council and secretary of defense and has begun to play a more active role in the formulation of the military budget. All of this, think military specialists, must lead to increased effectiveness of the work of the JCS and efficiency in the resolution of questions in its competence and to greater balance in the development of the service branches.

COPYRIGHT: "Zarubezhnoye voyennoye obozreniye", 1988.

Army Aviation of the French Ground Forces
18010239d Moscow ZARUBEZHNOYE VOYENNOYE OBOZRENIYE in Russian No 9, Sep 88 (signed to press 7 Sep 88) pp 17-22

[Article by Lt Col M. Simakov and Maj S. Blagov under "Ground Forces" rubric: "Army Aviation of the French Ground Forces"]

[Text] In its plans to raise the combat capabilities and mobility of its large formations and combined units, the command of the French ground forces is assigning great importance to the further development of army aviation, which it sees as an effective combat resource for the resolution of different tasks in contemporary combat and operations.

GENERAL POSITIONS: Army aviation as an independent combat arm arose at the beginning of the 1950's and went through several stages in its development. Initially it was based on light piston aircraft of American production ("Brussar" and "Cessna"), which performed limited tasks in carrying out battlefield reconnaissance, the evacuation of the wounded, etc. In the 1960's, units and subunits of army aviation began to be equipped with various types of helicopters that were assigned tasks in carrying out control and communications, the adjustment of artillery fire, the performance of air reconnaissance, etc. The 1970's were a period in the development of army aviation when helicopters with "Hot" antitank guided missiles began to go into operation. At the same time, missions and operational tactics for the subunits of army aviation were foreseen in the fire support of ground forces and in the engagement of tanks and other armored targets in the battlefield. Additional practical measures in the equipment of army aviation with up-to-date arms permitted a substantial expansion of its functions.

At the present time, it is capable of carrying out a large number of battlefield tasks, including fire support of the units and subunits of ground forces; the engaging of enemy tanks and helicopters; the performance of tactical reconnaissance; the command and control of troops and the maintenance of communications between staffs of large formations, combined units and units; the adjustment of artillery fire and rocket launches; the organization of battlefield surveillance and monitoring of the results of strikes against enemy targets; the performance of meteorological, topographic and radiation reconnaissance; assault landings; the redeployment of troops, combat equipment and articles of logistic and technical support; the evacuation of the wounded, etc.

The increase in the role of army aviation in contemporary combat and its provision with the latest combat equipment are forcing the command of ground forces to seek ways to improve the authorized organizational structure of its units and subunits. The program for the development of the armed forces adopted for the years 1987-1991 foresees the development of a new generation

of army helicopters for army aviation, which, in the opinion of specialists, can significantly increase the combat and maneuvering capabilities of its units and subunits.

At the present time, as the French press notes, the army aviation is made up of three separate regiments, army aviation units and subunits of an air mobile "rapid deployment force" division, seven separate groups, five detachments on foreign territory, eight separate helicopter squadrons, light aircraft subunits, two military schools, and one army aviation test group. The total number of personnel is about 12,000. The units and subunits have about 700 helicopters, including 150 SA341 and SA342 "Gazelle" with "Hot" antitank guided missiles, 70 SA316 "Aluett-3" with AS-11 antitank guided missiles, 130 SA330 "Puma" assault transport helicopters and 330 light helicopters (210 SA341 "Gazelle" and 120 SA313 "Aluett-2"), and 80 light aircraft.

According to the foreign press, the I Corps includes the 7th Regiment (Nancy) and the 11th Group of army aviation (Esse-le-Nancy), the II Corps includes the 2nd Regiment (Friedrichshafen, FRG) and the 12th Group (Freiburg, FRG), and the III Corps includes the 6th Regiment (Compiègne) and the 13th Group (Lille). The 4th Air Mobile Division (Nancy) is made up of the 1st, 3rd and 5th army aviation regiments (Falsburg, Etienne and Po, respectively). The army aviation groups of the military districts have their numbers and are stationed: I in Le Mureau, III in Penne, IV in Suj and V in Corba (Lyon). There are no such groups in the II and VI military districts; their functions are fulfilled by the army aviation groups of the army corps stationed in their territory. At the army aviation military school (Daks), there are 73 helicopters (18 light SA341 "Gazelle" helicopters and 55 SA313 "Aluett-2" helicopters) and the school for combat applications (Le Luc) has 50 helicopters (20 SA341 with "Hot" antitank guided missiles, 10 light SA341 "Gazelle" with 20-mm guns, and 20 SA330 "Puma" assault transport helicopters).

The overall leadership of the army aviation is accomplished by a commanding officer (staff in Villacuble), who is directly under the commander of the 1st Army. He takes part in the formulation of combat utilization plans and is responsible for operational and combat training, the structuring and acquisition of personnel, the provision with combat equipment, and logistic and technical support. Subordinate to him are the commanders of the army aviation corps as well as the commanders of individual units and subunits stationed in France and in foreign territories.

ORGANIZATION OF UNITS AND SUBUNITS. The basis of the army aviation is the separate army aviation regiments of the corps and the regiments of the air mobile division. In addition, as was noted above, it includes units and subunits under central, district and corps command.

In time of war, the **separate army aviation regiment** of the army corps can include seven squadrons: one for command and servicing, three for antitank helicopters, one for fire support helicopters, two for assault transport helicopters, and one for logistic and technical support. Altogether the personnel number 900 and there are 60 helicopters, of which 30 have antitank guided missiles. There are 220 motor vehicles and other arms. In peacetime, it includes six squadrons: one for command and servicing, two antitank (12 each), one for fire support helicopters (10), one for assault transport helicopters, and one for logistic and technical support—altogether 44 helicopters. It is proposed that the regiments be brought up to full wartime strength through the subunits of the army aviation military schools. Based on these schools, it is planned to deploy the 4th Regiment of army aviation for the 4th Air Mobile Division.

The command and servicing squadron is designated for the servicing of the regiment staff. It includes the platoons: command, routine servicing and maintenance, communications, medical, administrative and security.

The squadrons of antitank helicopters resolve tasks in the engagement of enemy tanks. It is thought that one squadron is capable of engaging armored targets in a zone of action extending 10 to 15 km along the front. Each of them has 10 SA342 "Gazelle" helicopters with "Hot" antitank guided missiles.

The squadron of air support helicopters can perform tasks in the destruction of enemy personnel, tanks and helicopters. It has 10 SA341 "Gazelle" helicopters with 20-mm guns.

The squadrons of assault transport helicopters basically serve to airlift troops to the battlefield, to provide logistic support for the large units and units, and to meet other objectives as well. This squadron can airlift up to a motorized infantry regiment (1,400 men) a distance of 20 km or 300 men (reinforced company) 100 km within 1 hour or a 120-mm mortar platoon 40 km within 20 minutes.

The logistic and technical support squadron performs tasks in the combat and logistic support of the regiment. It includes the platoons: command and servicing, anti-aircraft, maintenance and recovery, servicing and maintenance of helicopters, supply.

The **army aviation regiment of the 4th Air Mobile Division**¹ includes eight squadrons: one for command and servicing, three for antitank operations, and one each for reconnaissance helicopters, air support helicopters, assault transport helicopters and logistic and technical support. As foreign military specialists emphasize, their function, armament and combat capabilities are the same as those of the corresponding subunits of the army aviation regiments under corps command. Altogether the regiment has 60 helicopters, including 30 SA342 "Gazelle" with "Hot" antitank guided missiles.

As seen by the French command, the 4th Air Mobile Division is intended for the carrying out of combat operations in the Central European Sector in cooperation with the 6th Armored Cavalry Division in the support zone of the 1st Army (army corps) in the directions of movement of the enemy tanks and mechanized forces for the purpose of engaging tanks and other armored targets and the inflicting of strikes against his flank and rear. The division can also perform its combat tasks independently, especially in engaging enemy tanks. According to French press reports, division antitank helicopters can disable up to 300 enemy tanks in one combat sortie. The depth of the effect on the enemy can reach 250-300 km.

The **army aviation group of the army corps** is intended for the performance of air and chemical reconnaissance, the support of communications, logistic and technical support, and other tasks. It is composed of a command and servicing squadron and two light helicopter squadrons. Altogether its personnel number 350 and it has 20 light SA313 "Aluett-2" helicopters and 143 motor vehicles. An army aviation technical support detachment of a rear corps brigade has responsibility for its servicing and maintenance and for the repair of armament.

The **army aviation group of the military districts** performs tasks analogous to the tasks of the army corps groups and has the same organization and effective combat strength that they have.

Army aviation detachments in foreign territories are basically equipped with light SA313 "Aluett-2" or SA341 "Gazelle" and SA330 "Puma" assault transport helicopters. The army aviation detachment in Djibouti, for example, has five SA316 "Aluett-3" helicopters with AS-11 antitank guided missiles and five SA330 "Puma" assault transport helicopters.

Separate helicopter squadrons serve the staffs of the ground forces and 1st Army as well as the military schools: the infantry school in Montpellier, the school for armored cavalry forces in Sommieur, the artillery school in Draguignan, the school for engineering forces in Angers, and the school for communications forces in Pontoise. The number of helicopters in the squadrons ranges from 5 to 10.

Light aircraft subunits are represented organizationally by separate squadrons that can be attached completely or partially to army corps or military districts for the purpose of carrying on reconnaissance, supporting communications, etc.

Judging by reports in the foreign press, the organizational structure of the enumerated subunits and units corresponds to the current level of development of army aviation and contributes to the resolution of the tasks set before it.

COMBAT EMPLOYMENT. In the opinion of French military specialists, the units and subunits of army aviation must be utilized in cooperation with combined armored units or independently. In this connection, it is noted that the contemporary armament of helicopters, their high maneuverability and relatively great speed of displacement to the battlefield can significantly supplement the striking power of armored subunits in different types of combat operations. In particular, the use of helicopters in offensive operations can lead to a substantial increase in the rate of advance of armored (motorized infantry) units. In this event, army aviation should be given tasks in performing reconnaissance of combat procedures of enemy forces, fire support of attacking units and subunits, landing of assault forces for the capture of key terrain sections or positions, the defeat of advancing enemy reserves, etc. In defense, army aviation can be utilized to reinforce ground forces, to cover the probable directions of the enemy's advance, to redeploy troops and weapons—especially antitank weapons—in threatened directions, to land tactical forces in the rear of enemy forces advancing for the purpose of thwarting an offensive, to set up minefields in likely avenues of tank approach, and the like.

It is reported in the foreign press that the basic forms of combat employment of army aviation under today's conditions are air mobile combat and air mobile support, which the French command views as integral parts of combined arms combat (operation).

Air mobile combat—These are combat operations in the course of which helicopter subunits engage the ground enemy independently or in cooperation with a tactical landing force and ground forces. Its basic stages are reconnaissance, fire support and airborne landing of troops.

Reconnaissance in the interests of large strategic formations and combined units can be carried out by army aviation subunits independently or in cooperation with reconnaissance subunits of ground forces. In the first instance, it is conducted by reconnaissance helicopters for the purpose of the more precise determination of the trace of the enemy's forward edge, refining of the main directions of his advance as well as breaches, boundaries and disruptions in his combat formations, positions of weapons, and the like. It is organized in more detail in terrain with complex relief when the enemy's antiaircraft defense is inadequately strong. It is considered that the squadron's reconnaissance helicopters can operate in pairs in a zone up to 40 km wide along the front and up to 120 km in three directions to define targets more exactly. In the second case, they establish so-called air mobile groups, which are infiltrated in the enemy's rear 3 to 8 km from the forward edge to perform reconnaissance in a specific region or to make previously received information more precise.

Fire support is accomplished for the purpose of engaging detected enemy armored and other targets directly by

helicopters with antitank guided missiles or by air mobile groups including helicopters and combined arms subunits formed for the period of combat.

It is considered that in one combat sortie a squadron of antitank attack helicopters can destroy 10 to 15 armored targets. One sortie under full utilization of the ordnance lasts 45 minutes. In 25 to 30 minutes, after rearming, the squadron can make another sortie. Subsequent sorties are at 90 minute intervals on account of refueling. It has been determined that each helicopter can carry out two to four combat sorties a day and launch up to 15 antitank guided missiles before it may be shot down.

The air mobile groups may include subunits with antitank guided missiles, fire support and assault transport helicopters and also antitank and other combined arms subunits. They are supposed to contribute to the development of the success of the advancement of troops or resolve different tasks in strengthening their defense and also carry out independent actions to cover likely avenues of tank approach and boundaries and flanks of combined units or units. It is considered that successive strikes of army aviation and ground forces (with air support) against the combat formations of combined enemy units, assembly areas and regroupings are an effective means of destroying tanks in offensive operations.

Troops may be landed to increase the rate of advance in specific directions, to seize and hold tactically important sections of terrain and enemy facilities, to resolve tasks for the control of specific areas, etc. To do this, it is proposed that assault transport helicopters of army aviation as well as military transport aircraft be committed.

Air mobile support as a form of combat support of troop operations takes place mainly in the changeover of combined units and units to defense. It can be conducted along axes or in the form of so-called position defense organized in previously determined regions directly in combat formations.

The air mobile support of the combat operations of troops along axes is carried out to cover possible directions of advance of the enemy's main forces with the purpose of not allowing his penetration into the combat formations of the defending forces. To perform this task, it is proposed above all that air mobile groups (antitank and fire support helicopters cooperating with specially designated combined arms subunits) be committed. In some cases, such groups can guarantee the conditions to introduce second echelons (reserves) into battle.

The purpose of the position defense of the army aviation subunits and combined arms formations is the holding of certain areas in the depth of the defensive configuration of the combined units and the prevention of their capture by an enemy who has broken through.

TRAINING OF ARMY AVIATION PERSONNEL takes place in army aviation military schools in Daks and its combat employment in Le Luc.

The military school in Daks trains helicopter pilots for all service branches (except air forces), civil defense and firefighting units. The period of instruction is 2 years. Organizationally it includes two squadrons. In the first, they train officers of the ground forces who have served 3 or 4 years, are in good health and express a desire to serve in army aviation units. Noncommissioned officers are admitted to the second. The training process is broken down into three stages. In the first, they inculcate orientation skills in the air during flights in aircraft and helicopters and piloting techniques under normal and difficult weather conditions. In the second stage, in the course of 9 weeks, the officers go through practical training in the role of air observers and also rehearse tasks in the adjustment of artillery fire. The third phase provides for the flying of a combat aircraft (145 hours logged flying time per trainee) as well as lectures and class sessions (280 hours).

In the school for the combat employment of army aviation, they train officers and noncommissioned officers with service experience in the military forces. In the course of 10 weeks there, the skills of helicopter pilots are perfected in flights taking into account the special features of the terrain, at low and extremely low altitudes, and with instruments, especially under the conditions of limited visibility and at night, and they polish the technique of launching antitank guided missiles, both with the use of simulators (up to 400 launches) as well as combat devices (one at the end of the training). About 20 percent of the pilots perform night flights under mountainous conditions. Twelve hours are allocated for this.

In recent years, these schools have been training women for the duties of pilots and navigators of light helicopters.

PROSPECTS FOR THE DEVELOPMENT OF ARMY AVIATION. According to analyses by the French military leadership, the role of army aviation in contemporary combat is increasing all the time. The tactic of carrying out combat operations with the use of attack helicopters, especially in the Central European Sector, is being actively developed and improved. Taking into account the experience in the utilization of army aviation in the Arab-Israeli wars and in Chad, research is being done on the questions of the interaction of armored units and army aviation subunits as well as the employment of helicopters for the engagement of enemy helicopters. It is considered that in the next decade the main efforts will be aimed at the building of new machines and the modernization of existing ones and at the improvement of the organizational structure of the units and subunits of army aviation and the means to employ it in combat. In 1987, in particular, France and Germany signed an agreement on the development and production of new helicopters, which are expected to go

to the forces in 1995. It is planned to produce for France 140 new attack helicopters and 75 helicopters designated for the engagement of enemy helicopters (they will be armed with 30-mm guns and "Mistral" rockets of the air-to-air class with a launch range of 400-5,000 meters). It is proposed that these helicopters be given up-to-date equipment for flights under difficult weather conditions and under the conditions of limited visibility, an improved system for the aiming of weapons, etc. In November 1987, France, the FRG and Great Britain signed an agreement on the development and production of a third-generation antitank guided missiles with a range of fire of up to 5,000 meters. In addition, it is planned to replace the SA330 "Puma" assault transport helicopters by 1997.

Footnotes

1. The division is made up of six regiments: command and support (Nancy), air-mobile support (Falsburg), three army aviation regiments (one each in Falsburg, Etienne and Po), and a motorized infantry air-mobile regiment (Saarburg). Altogether the personnel is 6,400 and there are 12 120-mm mortars, 45 launchers for antitank guided missiles, 241 helicopters including 90 with "Hot" antitank guided missiles, 70 light SA341 "Gazelle" helicopters, and more than 80 SA330 "Puma" helicopters.

COPYRIGHT: "Zarubezhnoye voyennoye obozreniye", 1988.

American Ground Radio Communications Systems in the Millimeter Band

18010239e Moscow ZARUBEZHNOYE VOYENNOYE OBOZRENIYE in Russian No 9, Sep 88 (signed to press 7 Sep 88) pp 23-28

[Article by Sr Lt A. Skordumov: "American Ground Radio Communications Systems in the Millimeter Band"]

[Text] The command of the U.S. Army is paying considerable attention to the improvement of military systems and communications facilities, which are supposed to guarantee greater speed and undetectability in the transmission of information and have a high protection against interference and functional reliability under the conditions of the conduct of military operations utilizing conventional as well as nuclear weapons. In addition, higher demands are being placed on the efficiency of the setting up of communications and its flexibility as well as on the mobility of ground stations. According to American specialists, one possible way to meet the enumerated demands in the tactical level of command and control is the utilization of the promising technology of the millimeter waveband in ground communications systems.

At the present time, among the basic means of multichannel communications in the divisions of the U.S. ground forces are ultrashort-wave radio relay stations providing for communications within the limits of the line of sight and also landline communications equipment utilizing multiple-strand and coaxial cables.

The distance between two radio relay stations is usually 40 to 50 km. Their directional antennas, as a rule, are thereby put on poles higher than local objects. For this reason, they are easily detected and are poorly protected against the means of electronic warfare and engagement by weapons.

Wire communications provide for dispersed communications in terrain and for the linking of the division and corps to the base multichannel communications network. The communications line is kilometers in length and tens of kilometers when retransmitters are utilized. Among the well-known shortcomings of wire communications systems are the significant time needed to unroll and roll up the cables and the large expenditure of manpower and material resources. In addition, wire communications lines are vulnerable to the effects of conventional and nuclear weapons, are easily detected visually, and can be damaged by transport equipment and subversive groups.

The main shortcomings of up-to-date multichannel communications systems under the conditions of large-scale electronic warfare are their inadequate mobility and survivability.

Multichannel lines interlink communications centers, some distance from which command posts are usually located. At the same time, in the opinion of American specialists, to ensure survivability these posts must be as far as possible from radio-emitting communications facilities that the enemy can detect and destroy quickly. With adequate dispersion, the destruction of individual communications facilities will not mean the destruction of a command post, because with the help of narrow-band systems one can guarantee reserve communications with the higher command and subordinate units until multichannel communication lines are reestablished. At the present time, however, the use of wire connecting lines means that such dispersion leads to significant losses of time for the unrolling and rolling up of communications centers, which intolerably reduces their mobility.

It is precisely for this reason that American military experts believe that communications facilities of the millimeter waveband can play an important role in improving the survivability of command posts widely separated from each other and dispersed in the terrain, for they are resistant to the effects of the enemy's electronic warfare and are also sufficiently secret, highly reliable in their functioning and mobile.

Figure 1. Frequency Characteristics of the Specific Loss of Radio Waves in the Transparent Atmosphere (solid line) and in the Presence of Precipitation (dashed line)

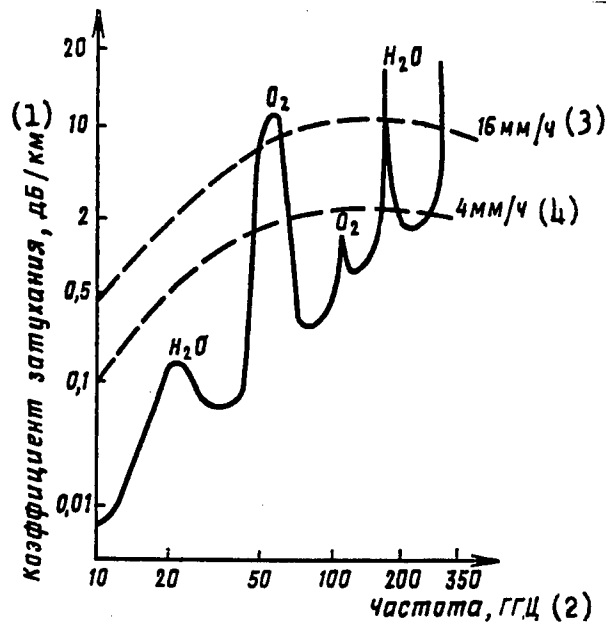

Key:

1. Coefficient of loss, db/km
2. Frequency, ggts

The necessity of assimilating this waveband is also dictated by the overloading of the lower-frequency bands, and broad-band communications systems of the millimeter waveband make it possible to process the ever-increasing flow of information necessary for transmission to the battlefield and for the functioning of new arms systems. On the other hand, the successes achieved in the technology of the solid-state equipment and components of the millimeter waveband have made it possible to develop different communication systems for work at frequencies higher than 30 gigahertz.

The resistance of communication systems of the millimeter waveband to the effects of the enemy's electronic warfare is explained by the difficulty in detection, directional finding and jamming in this frequency range as a result of the narrow radiation pattern of the antennas and low power of the transmitters as well as by the high degree of loss of radio waves in the atmosphere (Figure 1). As you know, the basic reason for the loss is precipitation (with the exception of those frequency sections where there is a resonance absorption of radio waves by atoms of oxygen and water vapor). Despite the fact that there can be an interruption of communications because of high-intensity precipitation, the number of interruptions can be reduced to 0.1 percent of the entire communication time. To do this, it is necessary to perform

the appropriate calculations of the ground communication line for the necessary range in a given specific climatic zone (reliable communications are ensured for a range of 6 to 8 kilometers).

Inasmuch as a significant loss of signal strength in the atmosphere impedes the use of the millimeter waveband for communications at longer distances, it is possible to communicate within the limits of line of sight primarily in the tactical command echelon. To organize communications at a greater range (at least 8 km), one can utilize the frequency band located in the so-called "window of transparency" of the atmosphere: from 30 to 51.4 gigahertz. The existence in the frequencies of 54 to 60 gigahertz of a peak absorption of radio waves by atmospheric oxygen in combination with the utilization of small antennas with narrowly directed emission increases the undetectability of communication, because it becomes improbable to detect radio transmissions in this sector of the spectrum with the help of radio reconnaissance systems. In these frequencies, therefore, it is possible to realize an operational mode that is close to that of the so-called "active radio silence" (instead of passive [radio silence] in the lower-frequency bands). Moreover, the broad-bandedness of the communications system of the given band makes it possible to increase the protection against jamming and undetectability of communications by utilizing noise-type signals with a diffuse spectrum.

A high degree of reliability of the communications systems of the millimeter waveband is also determined by the difficulty of visual detection of communication facilities, the impossibility of the accidental or intentional damage to communication lines, and the greater resistance to nuclear blast factors in comparison with the systems of lower frequency ranges. Thus, atmospheric ionization and turbulence as well as dust pollution of the atmosphere can lead to a disruption of communications only for a short time—from several seconds to several minutes. Long-term changes in the atmosphere as a result of a nuclear explosion, which produces a prolonged loss of communications at lower frequency ranges, do not worsen communications in the millimeter waveband. In addition, the influence of the multiple-beam diffusion of radio waves is less noticeable at these frequencies and less clearance is required in the direct line of sight.

The mobility of the communication systems of the millimeter waveband is determined by the small amount of time to unroll them and roll them back up (15-20 minutes), which, in turn, is determined by the small dimensions and weight of the equipment. Achievements in the area of solid-state technology play a significant role in this. Thus, the weight of the experimental models of transceivers with antennas is less than 7 kg and the antenna, providing for an amplification factor of 40 decibels, has a diameter of less than 60 cm.

The land forces of the United States have been developing experimental military ground communication systems of the millimeter waveband since the mid-1970's. Through theoretical and experimental research, including field tests of experimental models of equipment, they confirmed the possibility of ensuring reliable communications in this waveband. Since the beginning of the 1980's, most scientific research and experimental design work in this area has mainly been performed within the scope of two programs: MCPR (Multichannel Command Post Radio) and MISR (Mobile Intercept-Resistant Radio).

As a result of the performance of scientific research and experimental design work under these programs, it is planned to build inexpensive ground transceivers resistant to electronic warfare systems and functioning in the frequency ranges of 36 to 38.6 GHz and 54 to 58 GHz ensuring the fulfillment of the imposed tactical and technical requirements. The following versions of their utilization are proposed:

- concealed multichannel communications for short ranges;
- organization of lines for remote control of radio-emitting facilities and communications in a dispersed command post;

—replacement of sections of cable during combat operations and routing of communications in circuitous directions;

—remote transmission of reconnaissance information and concealed communications with separate special groups;

—communications in echelons "aircraft-aircraft" and "aircraft-ground station";

—"friend or foe" identification system;

—linking to the network of echelons "division-corps";

—communications in armored and helicopter subunits in periods of "active radio silence."

Let us examine in more detail the special structural and technical features of transceivers of the millimeter waveband developed under each of the research programs.

For communications with command posts of the United States ground forces under the MCPR program, experimental models of mobile ground stations in the range of 36 to 38.6 GHz were worked out by the firm "Norden Systems" and underwent field testing. In a double mode, they provide for the exchange of broadband analog and digital information with a speed of up to 20 megabits/second in one of five barrels at a range of up to 8 km. Also possible is the simultaneous work of five adjacent communication lines with no danger of mutual interference. The MCPR transceivers are compatible with different types of channel-forming and terminal military communications equipment, including that utilized in systems created under the programs TRI-TAC, ATACS and others.

Structurally the MCPR transceiver is implemented in the form of two blocks: a primary block located on a tripod and an auxiliary block linked with the primary block by means of a cable. The first includes a transceiver and an antenna device and the auxiliary block includes buffer connections, remote control elements and a power pack. Such a design is convenient for servicing and, most important, it makes it possible to reduce losses in the signal level through the minimal length of high target frequencies. The auxiliary block also provides for a separate telephone channel for service communications and for the possibility of checking the equipment "loop."

The transmitting part of the transceiver is composed of a generator with a Hann diode, a varactor diode element, a dielectric generator load, an attenuator and thermo-static elements in a separate block. The microprocessor frequency tuning of the broad-band generator is done by changing the voltage on the varactor within 20 var; this is sufficient to cover the entire working frequency range.

Figure 3. Diagram of the Polarization Division of the Receiving and Transmitting Channels of a Millimeter Wave-band Radio Station

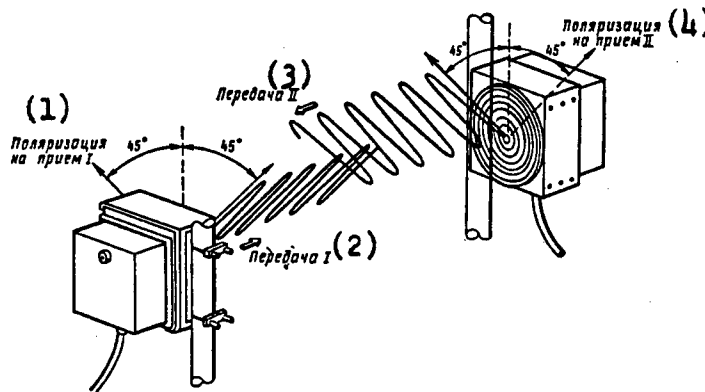

Key:

1. Polarization for reception I
2. Transmission I
3. Transmission II
4. Polarization for reception II

A low-frequency signal is given directly to the bias circuit of the Hann diode, which provides for the frequency modulation of the emitted signal.

The receiving part of the transceiver includes an input filter, a heterodyne on a Hann diode, a broad-band transformer, a low-noise preamplifier and an intermediate-frequency filter. The domestic heterodyne on the Hann diode differs from the one described above only in the magnitude of the output power and in the necessity of conformity with the broad-band transformer. In addition, it is the controlled element of the system for automatic frequency tuning.

In the broad-band transformer, use is made of two low-noise amplifiers with arsenide-gallium diodes of a balanced structure to reduce the noise coefficient in the transformation of the frequency to the level of 4.5-5 decibels.

The antenna-feeder system of the transceiver consists of a polarized selector, a wave-guiding adapter from the rectangular to the round profile, and a horn irradiating a lens 28 cm in diameter made of Rexolite. The horn feed can simultaneously work on radio waves with orthogonal polarization: horizontal and vertical. They are divided in a polarization selector. Such a polarization uncoupling of the receiving and transmission channels makes it possible to provide for the double work of the transceiver with one antenna in the absence of retunable dividing tuners. In setting up the communications, the horn is oriented so that the directions of the received and transmitted radio waves are at a 45-degree angle to the vertical (Figure 3). In the case at hand, rain falling on the communication route will influence the polarization of the transmitted and received signals equally. In addition,

the receiving and transmitting high-frequency modules are arranged symmetrically in the primary block of the transceiver. The vertical-horizontal orientation of the polarization of the radio waves would require an asymmetrical arrangement of the high-frequency modules in the body of the primary block to ensure conformity in polarization between operators.

A lens transforms the spherical phase front for the horn irradiation into a flat one. A covering of a composite material based on polystyrene and quartz is applied to protect its surface against dust, moisture and abrasive wear. Zoning of the lens makes it possible to reduce its weight and thickness and, consequently, losses in material. At the same time, however, its surface is shaded somewhat and there is a certain distortion of the phase front in the extreme frequency ranges. The choice of Rexolite as a lens material is dictated by the small high-frequency signal loss and reflection. A coniform metallic diaphragm, fastened with the help of a bracket, shields the receiving part of the transceiver from outside radiation and the absorber attached to its inside surface lowers the level of the side lobes of the radiation pattern to -22 decibels relative to the primary maximum. The amplification factor of the antenna is equal to 36 decibels, which corresponds to the width of the radiation pattern, 2.2 degrees.

One of the developed experimental models of the MCPR transceiver was successfully used during exercises to establish communications at a range of 12 km. Thirty minutes were spent in extending the masts to ensure a direct line of sight and to establish communications.

In the scope of the MISR program, the firm Hughes Aircraft developed multichannel transceivers for the U.S. ground forces for short-range communications,

characterized by high resistance to radio interception and countermeasures. The main factor determining this resistance is the working frequency range of these transceivers—54 to 58 gigahertz, which is characterized by an anomalously high value of loss of radio waves on account of their resonance absorption in atmospheric oxygen. The amount of loss increases from 2 decibels/km at a frequency of 54 gigahertz to 12 decibels/km at a frequency of 58 gigahertz. The algorithm of adaptive retuning of the transceiver frequency specifies that in the establishment of communications the receiving parties utilize the lower part of the frequency range with a minimal level of signal loss, after which there is automatic retuning to an area of higher frequencies, where the level of signal loss ensures optimum conditions for radio communications. In the process, the level of the received signal will correspond to the required reliability and possibly greater undetectability of communications. Such an adaptation occurs for any structure of the communications line and compensates for atmospheric effects on the quality of communications. The nominal range of communications under line of sight conditions is 4 km with a transmitting power of 100 milliwatts. The transceivers transmit multichannel information in digital form at a speed of up to 4.9 megabits/hour with an error rate of no worse than 10^{-5} and also transmit a standard television signal with a sound track. A characteristic feature of the MISR transceivers is their capability of functioning completely autonomously, which increases their mobility even more.

Structurally the MISR transceiver is composed of primary and auxiliary blocks linked by a cable 15 meters in length. The transformer of direct to alternating current, located in the primary block, allows it to function autonomously in the presence of a source of direct current at a voltage of 26 volts. Despite the additional design complexity caused by the need for autonomous work, however, the transceiver is rather compact.

The functional arrangement of the transmitter includes a driving generator of the millimeter waveband on a Hann diode retuned with the help of a varactor and utilizing microprocessor adaptive frequency tuning. It also includes a triple-cascade amplifier on indium phosphide diodes with an amplification factor of 10-15 decibels, which provides for a transmitter output of 100 milliwatts in the entire frequency range. A double transformation of frequency takes place in the receiving apparatus with subsequent signal processing by the readjustable filter, which makes it possible to achieve the highest possible amplification factor at the lowest allowable value for the intermediate frequency. The transceiver works on fixed linked frequencies, whereby part of the power of the driving generator of the transmitter is utilized as the heterodyne signal. This makes it possible to improve the weight and size specifications and to reduce the power consumption, since the generator on the Hann diode uses only 8 watts. Provision is also made for the efficient functioning of the adaptive radio communications line, in which one transceiver leads and the other follows. The

frequency dispersion for receiving and transmitting is 500 megahertz. The use of frequency modulation permits its direct application in the working range of frequencies, which improves the power performance of the transmitter, for there is no longer any need for additional modifications in the transmission channel.

The transceiver's antenna system was chosen after lengthy research proceeding from the fact that it was necessary to carry out two-way communication using a joint high-directional receiving and transmitting antenna having a low level of side and rear radiation. A lens antenna irradiated by a horn was found to be most acceptable for work in the millimeter waveband. It has an axially symmetric radiation pattern with an almost constant width of the major lobe in the entire frequency range and a very small level of side and rear radiation. The lens in the MISR transceivers is made of Rexolite and the horn is made using the electroforming method. The antenna has an amplification factor of -35 decibels (width of the radiation pattern is 2.8 degrees) at a level of side radiation of 26 decibels. It is located within the body of the transceiver, which significantly increases its mechanical strength, although at the same time it increases the dimensions of the primary block. The lens itself is strengthened with the help of a coniform aluminum jacket, the inside surface of which is covered with an absorber. The polarization selector separates the emitted and received radio waves with orthogonal polarization. In the process, a transitional loss occurs between the receiving and transmitting channels equal to 34 decibels compared with 20-23 decibels in the traditional channel separation through a circulator. This made it possible to reduce significantly the demands on the receiving elements of the receiving channel.

One of the versions of the MISR transceiver was utilized during exercises. Four sets with nondirectional antennas were set up on M60A1 tanks. It was reported that one-way telephone communication was achieved for ranges up to 1 km in movement. In the utilization of directional antennas requiring precise adjustment in the direction of the operator at the other end, the distance between stationary operators reached 4 km.

Based on the work carried out in the MCPR and MISR program, American specialists are studying new concepts for tactical communication systems in the millimeter waveband:

—the WICS (Wireless Intracell Communication System) based on multistation access with temporary separation of channels;

—a system of secret network communications in armored and helicopter subunits to permit the functions of communication and control in the frequencies of 54 to 58 gigahertz for work during periods of radio silence;

—a system of secret communications of increased mobility, dispersion and survivability for an entire class of arms systems.

The system of wireless intracell communication developed under the WICS program is intended to ensure secret radio communications at a dispersed command post. It is composed of six transceivers forming a network of secret short-range communications. Four operating modes are foreseen in each transceiver:

—Narrow-band telephone communications with mobile facilities in the range of 55 gigahertz at a distance of up to 1 km utilizing nondirectional antennas and frequency modulation of signals.

—Communications of a fixed central transceiver operating in the mode of selective switching, with conducted transceivers. The central transceiver, having a nondirectional antenna, effects the synchronization and adaptive control of the frequency of all conducted transceivers. A relative phase manipulation is used for the transmission of signals through the method of multichannel access with temporary separation of channels.

—Communications link of the conducted transceiver with the central transceiver through a directional antenna having a high amplification factor.

—The mode of retransmission of signals for an increase in the range of the communications link of the central transceiver with a conducted transceiver with the help of an intermediate transceiver.

The choice of the nondirectional or directional antenna is made by means of a wave-guide switch providing for a separation between two channels equal to 60 decibels.

The layout of the standard fixed position of the dispersed command post utilizing a WICS transceiver for telephone communications and the transmission of data provides for the location of the leading transceiver in the center and the conducted transceivers in a radius of up to 1 km around it. The operators of the conducted transceivers must aim their antennas in the direction of the leading transceiver. Figure 5 shows a compact module that includes the antennas and elements of the millimeter waveband. This module can be oriented in the necessary direction and set with the help of a mounting device. It is tuned at the maximum of the received signal controlled by a sound tone signal in headsets. After tuning, the operators, using a telephone channel for official communications, switch the transceivers to the adaptive mode of operation, in which there is a simultaneous retuning of the frequency. The process of adaptive tuning guarantees the achievement of the maximum acceptable level of loss in the worst communications channel, which makes it possible to achieve maximum undetectability in communications. The WICS system is designed to work without mutual interference between individual transceivers when operating in any mode.

Figure 5. Design Version of the Basic Module of the WICS Transceiver

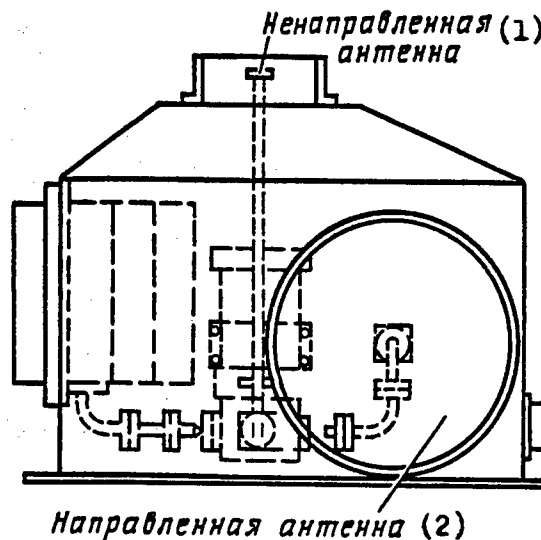

Key:

1. Nondirectional antenna
2. Directional antenna

A biconical antenna actuated by a horn is used as a nondirectional antenna in the transceiver. Its diameter is about 1.5 cm and its height is 0.6 cm, which provides for a nondirectional radiation pattern in the azimuthal plane and a width of its angle of site equal to 42 degrees. The amplification factor of the antenna is 3.2 decibels. At the same time, the necessary mechanical rigidity and design simplicity are achieved.

A parabolic antenna with a diameter of 12 cm with a horn feed providing for an amplification factor of 35 decibels at a level of side lobes of 20 decibels is used as a directional antenna. The width of the radiation pattern is thereby 3 percent. The cylindrical protective screen around the parabola reduces the level of rear radiation to -50 decibels relative to the radiation pattern maximum. A rigid Teflon plate with a low level of absorption of radio waves protects against moisture.

Thanks to their small dimensions and weight as well as rapidity of initiation of communications, the transceivers of the WICS system require a minimum amount of time for a change of position and deployment. This ensures a high degree of mobility, which, along with undetectability, can make the WICS system of wireless communication quite promising for utilization at a command post dispersed in the terrain.

Taking into account the great possibilities of the communications systems of the millimeter waveband at the tactical level of command, U.S. specialists are now continuing intensive research in this area. It is primarily concentrated in the following directions:

—study of the properties of the propagation of radio waves in the millimeter waveband in the urban zone, forest tracts and rural areas;

—development of dielectric and microband antennas as well as elements of the feeder tract and generators on solid elements;

—experimental rehearsal of new concepts to guarantee communications under the conditions of the use of nuclear weapons and intensive utilization of the means of electronic warfare.

One can therefore expect that there will be an increase in the number of developments of equipment in the millimeter waveband and that in the future communications systems in this waveband may find applications in the U.S. ground forces.

COPYRIGHT: "Zarubezhnoye voyennoye obozreniye", 1988.

Self-Propelled Howitzer G-6

18010239f Moscow ZARUBEZHNOYE VOYENNOYE OBOZRENIYE in Russian No 9, Sep 88 (signed to press 7 Sep 88) pp 29-30

[Article by Col Ye. Viktorov: "Self-Propelled Howitzer G-6"]

[Text] In the Republic of South Africa, the state firm Armscor has built a 155-mm self-propelled howitzer that has been given the designation G-6. Its development began at the end of the 1970's and the first experimental model appeared in 1981.

In contrast to all self-propelled guns existing in capitalist countries, the G-6 utilizes a wheeled instead of a tracked chassis. This choice, according to South African military specialists, was dictated above all by the peculiarities of the terrain relief of the region as well as by the necessity of having a large range for the self-propelled combat equipment employed by the ground forces.

The design of the self-propelled howitzer G-6 is represented in Figure 2. The guidance compartment is located in the front part of the body and behind it is the motor and transmission compartment. Then comes the fighting compartment, which also includes an armored turret that can be rotated in a circle. The body is made of welded armor plates that protect it against small arms fire and fragments of artillery shells. The bottom has reinforced armor against the action of land mines.

A 525-hp air-cooled diesel engine is used as the propulsion unit on the G-6. It is linked with an automatic transmission providing for six forward gears and two reverse gears. All wheels of the self-propelled gun are drive wheels.

Figure 2. Schematic Representation of the G-6 Self-propelled Gun

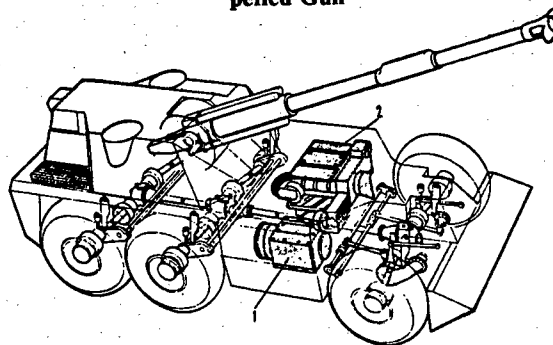

Key:

1. Transmission
2. Engine

In the series models of this self-propelled gun, the wheels have independent torsion suspension with hydraulic shock absorbers. It is turned off during fire. Prior to this, with the help of the hydraulic system, four supports are lowered (from the sides of the front and rear parts of the body). The foreign press notes that, despite the significant combat weight (36.5 tons), the G-6 self-propelled howitzer has good mobility. Its maximum highway speed is 90 km/hour and 35-40 km/hour in rough terrain. The range is 600 km. It can negotiate a slope of up to 30 degrees, a ditch 1 meter wide, a wall 0.45 meter high, and a ford up to 1 meter deep.

The basic armament of this self-propelled gun is a 155-mm howitzer located on the armored turret. The aiming angles of the gun are from -5 degrees to +75 degrees in the vertical and all 360 degrees in the horizontal. The drive system is electrohydraulic. A shell rammer is arranged on the left side of the breech mechanism to facilitate loading. The powder charges (in a combustible cartridge case) are placed in the loading chamber manually. A well-trained combat crew achieves a rate of fire of four rounds/min during the course of 15 minutes.

For firing from the howitzer, use is made of rounds with high explosive fragmentation, smoke, illuminating and incendiary shells. The carried ammunition is 47 shells and 52 charges. The maximum range of fire with a conventional high explosive fragmentation shell is 30 km and 39 km with a high explosive fragmentation shell with a special bottom pyrotechnic grenade launcher attachment.

The fire control system includes, in addition to day and night sights, a laser rangefinder and a ballistic computer. It can be connected to the battery fire control system, obtaining all necessary data for firing.

Four people are accommodated in the armored turret: a commander, a gunner and two loaders. For their entrance and exit, there is a door on the right side and

two hatches on the turret roof. Gun ports are located on the sides for the delivery of fire from the 5.56-mm R-4 automatic rifles. Vision devices are mounted over them. Four-barrel smoke grenade launchers are found to both sides of the gun in the front part of the turret. The commander's cupola is equipped with periscopes for a circular field of view. A 12.7-mm machinegun is mounted in front of the loader's hatch. It can be used for firing at ground as well as air targets.

Organizationally the G-6 self-propelled howitzers will be included in batteries (eight in each battery). Three batteries constitute an artillery regiment. The management of the Armscor firm does not exclude the possibility of selling this self-propelled gun to other capitalist countries, in particular in the Middle East.

COPYRIGHT: "Zarubezhnoye voyennoye obozreniye", 1988.

American F-111 Aircraft

18010239g Moscow ZARUBEZHNOYE VOYENNOE OBOZRENIYE in Russian No 9, Sep 88 (signed to press 7 Sep 88) pp 36-40

[Article by Col P. Ivanov under "At the Request of the Readers" rubric: "American F-111 Aircraft"]

[Text] The development of the multipurpose F-111 aircraft with variable wing geometry began at the end of the 1950's, when the U.S. Air Force command came to the conclusion that it was necessary to build a new combat aircraft capable of replacing the tactical fighter F-105 "Thunderchief." At the same time, the demand was made that the new aircraft have the flying speed of a fighter, the payload of a bomber and the range of a transport aircraft. After evaluating the competing projects proposed by the firms General Dynamics and Boeing, the former was chosen to develop it. The Grumman Corporation also took part in the implementation of the F-111 program. The result was the creation of three basic versions of the aircraft: a tactical F-111 fighter with several modifications (A, B, C, D, E and F), a medium-range bomber FB-111A, and an aircraft for electronic warfare EF-111A.

It was first proposed to build more than 1,700 F-111 aircraft but their production was stopped in December 1976 after delivery of 562 aircraft. Of this number, the U.S. Air Force received 159 F-111A fighters (deliveries began in 1969), 96 F-111D's (in 1970), 94 F-111E's (in 1969), 106 F-111F's (in 1971), 76 FB-111A bombers (in 1969), and 42 EF-111A 's for electronic warfare (in 1981). In addition, Australia procured 24 fighters that were given the designation F-111C (their delivery began in 1973). Subsequently four of them were converted into RF-111C reconnaissance aircraft. An unsuccessful attempt was also made to build an anti-aircraft deck

fighter in the interests of the U.S. naval forces (developed by Grumman). Seven such aircraft were built but further work on the F-111B program was stopped because of financial and technical difficulties.

Below is a short description of the basic versions of the aircraft: the F-111A fighter, the medium-range bomber FB-111A, and the EF-111A for electronic warfare. Their tactical and technical specifications are given in the table.

Basic Specifications of Various Versions of the F-111

Specifications	Aircraft		
	F-111-A	FB-111A	EF-111A
Size of crew	2	2	2
Weight, kg:			
—Maximum takeoff weight	41,400	52,000	40,300
—Aircraft empty weight	21,000	21,500	25,000
Maximum speed, Mach number:			
—At high altitude	2.2	2.2	2.0
—At sea level	1.2	1.2	—
Service ceiling in meters	18,000	18,000	13,700
Ferrying range, km	5,500	6,600	3,700
Aircraft length, meters	23.2	22.4	23.2
Height, meters	5.2	5.2	6.1
Wingspan, meters:			
—At a sweep angle of 72 degrees	9.7	10.5	9.7
—At a sweep angle of 16 degrees	19.2	21.3	19.2

In its design, the F-111A fighter represents a monoplane with a high wing whose sweepback angle on the leading edge can vary in flight between 16 and 72.5 degrees. At cruising speeds, the wing sweepback angle is set at 26 degrees (such conditions provide for the maximum weight of external stores). The wing has five longerons and the skin of the central parts of the wing panels is made in the form of a single structural element. The lift augmentation devices include leading-edge flaps and double-slotted trailing-edge flaps located along the entire length of the panels. The fuselage of the half-monocoque type is basically made of aluminum alloys and steel and titan alloys are employed in the structure of the most important elements of the airframe. The tail assembly consists of a vertical tail with a rudder and a horizontal stabilizer. The panels of the stabilizer can be tilted symmetrically (in pitching movements) or differentially (when banking). Two ventral crests are utilized to increase the directional stability of the aircraft.

The landing gear is triple, the main gears each have one tire and the forward gear has two. The main landing gears are linked by a common structural element that is retracted into the central part of the fuselage. When the landing gear is extended, the tires of the main gears are positioned on both sides of the fuselage (between the fuselage and the air inlets of the engines). To prevent the skidding of the tires along the surface of the runway during the abrupt braking of the aircraft, the wheel brakes are equipped with an antiskidding system. During flight, the door for the main landing gears can be tilted down for use as an air brake.

The crew of the aircraft consists of two pilots whose seats are arranged next to each other. The cockpit canopy has two doors. The canopy doors (over each pilot) fold upward. Overall the cockpit represents an escape module in the event of an emergency situation. It provides for the rescue of the crew members in a great range of altitudes and speeds, including zero values. When the rescue system is activated, the module with the crew members separates from the aircraft, moves away from it with the help of a rocket booster with a thrust of 18.1 tons of force, and comes back to earth with the help of parachutes. Inflatable balloons are used to soften the impact of the module with the surface of the earth. If it lands in water, they perform the role of floats.

The propulsion unit of the F-111 fighters consists of two TF-30 turbojet bypass engines in various modifications that differ in their basic thrust. In particular, the F-111A, C and E utilize TF30-P-3 engines with an afterburn thrust of 8,400 kilograms each, the F-111D employs TF30-P-9 engines (10,400 kilograms of thrust) and the F-111F uses TF30-P-7 engines (9,200 kilograms of thrust). The aircraft fuel is located in the fuselage and wing tanks with a total capacity of 19,050 liters. The engine air inlets are adjustable and are located under the wing on the sides of the fuselage. In front of the air inlet of the left engine is a sleeve for the centralized refueling system under pressure and behind the cockpit above the fuselage is the fuel intake of the system for refueling in the air (it provides for fueling through gravity feed). Each engine activates an electric generator with a power of 60 kilowatts. The engines can be started with a solid-propellant starter. Usually one is started with the help of compressed air supplied by a ground facility and the other by bleeding compressed air from the compressor of the working engine.

Judging from the reports of the foreign press, the electronic equipment of the F-111 aircraft permits combat use at any time of the day or night under normal and difficult weather conditions. It includes a multifunctional radar unit, a radar unit providing for low altitude flight while following the topography, an inertial navigation and bombardment system linked with a ballistic computer, a radio altimeter, a doppler radar unit for measuring speed and drift, instrument landing equipment, the equipment of the TAKAN radio navigation system, a radio compass, a radar identification system, shortwave and ultrashort-wave transceivers, and various means of electronic warfare. The F-111F fighter is also equipped with the AN/AVQ-26 "Pave Tack" pod, which contains the AN/AAQ-9 infrared station for forward surveillance and the AN/AVQ-25 laser rangefinder and target designator.

The armament of the F-111 fighter is located in the bomb bay and on eight underwing pylons. Of them, the four inner ones (two under each wing panel) are revolvable and are set automatically through the airflow in changing the angle of wing sweepback. The other four are fixed; the two on the outside are hardly used to hang

weapons and the others are set by the airflow only when the wing sweepback angle is 26 degrees. The fixed armament of several modifications of the F-111 fighters consists of one six-barrel 20-mm "Vulcan" cannon with 2,084 rounds of ammunition. It is possible to hang the following: up to six nuclear bombs (two in the bomb bay and four under the wing); 24 high explosive Mk82 or M117 bombs of caliber 500 or 750 pounds, respectively; four GBU-15 or GBU-16 guided bombs. The aircraft is also capable of carrying high explosive Mk83 and Mk84 bombs of the 1,000 and 2,000 pound caliber, respectively, cluster bombs and "Sidewinder" guided missiles of the "air-to-air" class.

The **FB-111A medium-range bomber** differs from the fighter in its somewhat increased wingspan, modified engine air inlets, a more solid landing gear and energy-absorbing wheel brakes (which is dictated by the increase in the takeoff weight of the aircraft), the composition of the onboard electronic equipment and armament, and the more powerful engines. The maximum version for the loading of the bomber with nuclear weapons is six bombs or six SREM guided missiles of the "air-to-ground" class, two of which are located in the bomb bay and four under the wing. The normal version of mounting is two nuclear bombs or two SREM guided missiles and two to four underwing fuel tanks (each with a capacity of 2,270 liters).

The "**Raven**" **EF-111A aircraft for electronic warfare** was built by Grumman through the modernization of the F-111A tactical fighters. The development contract was signed in 1971 and flight tests of two experimental models began in 1977 and ended in 1979. The delivery of all 42 aircraft to combat units of the U.S. Air Force was concluded at the end of 1985. At the present time, the EF-111A's are based in the continental part of the United States and in Great Britain. These aircraft may be used to resolve the tasks of tactical aviation in providing direct support to ground forces and in isolating a combat zone. In the first case, an electronic warfare aircraft flies at low altitude and sets up jamming of radar used in the control of anti-aircraft missile systems and anti-aircraft artillery. In the second case, at medium-altitudes, it sets up jamming not only of radar but also of radio communications systems. Another important task of the EF-111A is to escort strike forces of tactical aircraft penetrating the enemy's anti-aircraft defense system.

To resolve the tasks assigned to it, the EF-111A is equipped with the AN/ALQ-99E system of electronic warfare devices, which detects, identifies and determines the location of enemy electronic systems and sets up jamming of them as well as sighting actions with respect to frequency and time. The basic elements of the system are receivers of the signals of electronic resources, 10 jamming transmitters, and a powerful computer that controls the work of the entire system. Some of the signal receivers are located on a special fairing on the vertical tail of the aircraft. In it, in particular, are six spiral

antennas providing for the reception of radio signals in different frequency bands. The jamming transmitters are located in the bomb bay of the aircraft and in a dorsal rib with a length of 4.9 meters. The weight of the electronic equipment in the bomb bay is 1,940 kg and that in the dorsal rib weighs 210 kg.

Combat use. The F-111A tactical fighters were used beginning in 1968 in the course of the U.S. aggression against Vietnam. They were generally armed with 24 Mk82 demolition bombs of the 500 pound caliber and had two suspended containers with AN/ALQ-87 electronic warfare equipment. Most often the aircraft were used at night and under difficult weather conditions 50 percent of the time. Altogether, according to the foreign press, about 74,000 bombs were dropped in more than 4,000 combat sorties. Six aircraft of this type were lost in the process of carrying out air combat operations.

In April 1986, 18 F-111F tactical fighters took part in the raid against Libya. The operations of these strike aircraft were achieved through the help of three EF-111A electronic warfare aircraft and 28 KC-10 and KC-135 tanker aircraft. Altogether 24 F-111F aircraft took off from the territory of Great Britain but six of them (reserve aircraft) returned to the base as the first refueling in the air. The flight route was along the west coast of France, Spain and Portugal, across the Strait of Gibraltar and over the Mediterranean Sea along the north coast of Africa. The overall length of the flight was about 10,000 km and it lasted 13-14 hours. The aircraft were each refueled four times during the flight to Libya and twice on the way back. EF-111A aircraft were used during the course of this aggressive raid to perform active jamming of the radar stations of the Libyan anti-aircraft missile systems and radio communications equipment.

Most of the F-111F fighters carried four 2,000-pound GBU-10 guided bombs with a laser aiming system and several were armed with twelve 500-pound guided bombs. The targets were first detected with the help of onboard radar and the short-range tracking and identification of targets was through the infrared station of the "Pave Take" system. Individual aircraft approached the target at a speed of about 925km/hour and an altitude of 120 meters. Five F-111F's did not carry out their bombing mission in the course of the flight for various reasons and one did not come to the point of rendezvous with the tanker aircraft and was lost.

Tests of the adaptive wing. In October 1985 at Edwards Air Force Base (state of California) in the United States, they began the first stage of the flight testing of the AFTI/F-111 aircraft with a wing whose camber can change smoothly depending upon the flight conditions. Such a wing, called an adaptive wing, makes it possible, according to American specialists, to optimize the aerodynamic quality of the aircraft in different flight configurations and also to improve the specifications of its controllability and maneuverability. For the tests, they

utilized one of the F-111 experimental fighters on which an adaptive wing had been mounted. A special feature of its design is its provision with three-section trailing-edge flaps and one-section leading-edge flaps having a flexible skin made of composite material and glass-reinforced plastic. The section curvature most acceptable for such flight conditions is set with the help of hydraulic drives linked to a digital computer. The trailing-edge flaps can be tilted downward only (1 to 18 degrees) but the leading-edge flaps can be tilted from 1 degree upward to 20 degrees downward. And the sections of the trailing-edge flaps near the fuselage can be tilted only symmetrically, whereas the middle and outer ones can be tilted both symmetrically and differentially, which makes possible control while banking.

In the course of the first stage of the tests (October 1985 through November 1986), the functioning of the adaptive wing was evaluated in the following four modes: maintenance of the maximum cruising speed at constant engine thrust; provision of the maximum coefficient of aerodynamic lift while maneuvering the aircraft; control and regulation of the bending moment in the basic parts of the wing panels; reduction of the influence of a turbulent atmosphere on the normal load factor. Altogether 26 flights with a total duration of 58 hours were made during this stage of the testing.

The second stage of the testing of the AFTI/F-111 aircraft began in August 1987. The test modes remained practically the same, only the curvature of the camber is selected and set completely automatically depending upon flight conditions. After evaluating each mode separately, it is planned to combine two of them (sometimes more) to determine their mutual influence on the controllability and dependability of the aircraft's piloting. American specialists consider one of the aircraft's important advantages to be the fact that the variable sweep of its wing permits the assessment of the possibility of using the adaptive wing in different types of aircraft. They believe that the utilization of the adaptive wing will make it possible to increase the range by 25 to 30 percent and the available load factor by 25 percent in the performance of set turns.

The second stage of the tests of the AFTI/F-111, in the course of which it is planned to carry out 30 to 35 flights, was supposed to last until July 1988.

Modernization of the electronic equipment. The command of the U.S. Air Force is carrying out a program for the staged modernization of the electronic equipment of all modifications of the F-111. This program, which is estimated to cost about \$3 billion, must be completed by the middle of 1992. Its realization is supposed to improve the capabilities of the F-111 aircraft to perform the tasks assigned to it by a factor of approximately four. At the same time, the task was set of improving significantly the reliability of the functioning of the electronic

equipment. This is especially important when one considers the fact that the mean time between failures is 2-3 hours (the mean flight duration of the F-111 is 4.5 hours) but it is planned to increase it to 19.6 hours through its modernization.

The main directions in the modernization of the electronic equipment are the replacement of the analog flight control system with a digital system and half of the modules with a multifunctional radar system and a radar system for flight support in the topography-tracking mode and also the mounting of a navigation system on a laser gyroscope and a new electronic warfare system. It is also planned to replace the astrocompass on the FB-111 bombers with a doppler navigation radar and to equip the cockpit with a new multifunctional display. It was initially planned to develop a new built-in electronic warfare system for the F-111 aircraft but its development was estimated to cost approximately 30 to 70 percent more than the planned sum. In this connection, the command of the U.S. Air Force declined to equip the F-111 aircraft with such a system and is searching for less expensive ways to improve the onboard electronic warfare devices.

The modernization of the electronic warfare system of the EF-111A foresees the establishment of new output stages for the jamming transmitters and a signal-processing processor with an increased capacity of the memory unit. It is thought that this will make it possible to expand the capabilities of the system, including for the jamming of radar sets working with frequency retuning.

The American specialists believe that the modernized F-111 aircraft can be in operation until at least the year 2010.

COPYRIGHT: "Zarubezhnoye voyennoye obozreniye", 1988.

Utilization of the Achievements of Oceanography for the U.S. Naval Forces

18010239h Moscow ZARUBEZHNOYE VOYENNOYE OBOZRENIYE in Russian No 9, Sep 88 (signed to press 7 Sep 88) pp 45-49

[Article by Reserve Capt 1st Rank, candidate of geographic sciences and lecturer, and Capt 2nd Rank V. Katenin, candidate of technical sciences, under the "Naval Forces" rubric: "Utilization of the Achievements of Oceanography for the U.S. Naval Forces"]

[Text] Contemporary naval weapon systems and military equipment are capable of effective operation under rather difficult environmental conditions, which nevertheless can have a substantial negative impact on their utilization.

Interest in oceanography increased noticeably with the appearance in the navy of missile weapons, nuclear submarines, and up-to-date aircraft and helicopters. With the increasing complexity of weapons and of the tactics for their use, the influence of the environment is becoming a more and more important factor, which must be taken into account in the designing and exploitation of prospective models. This circumstance dictates the necessity of the closest cooperation between developers of equipment and oceanographers in the process of searching for fundamentally new design solutions.

At the present time, in the opinion of foreign military specialists, it is necessary to have a precise, up-to-date and reliable forecast of the state of the environment for an assessment of its influence on the employment of naval weapon systems and also to be able to overcome its unfavorable effects or, on the contrary, to utilize beneficial factors for the purpose of establishing the very best conditions for the employment of their own forces.

Table 1 presents information on the applied utilization of oceanographic data to carry out the operations of the U.S. Naval Forces.

Table 1. Areas of Application of Oceanographic Data in the Interests of the Naval Forces

Oceanographic Data	Areas of Application
Maritime surface winds	Forecast for flight support Forecast for support of ship passages Forecast of swells and breakers in support of: —landing operations —actions of combat swimmers —resupplying of ships under way at sea Support of the employment of sea-launched ballistic and cruise missiles Forecast of extraneous noise at the sea surface in the interests of antisubmarine actions Forecast of radar observability
Nature of the dependency of temperature, salinity and density of the water upon the ocean depth	Determination of the optimum diving depth of submarines under different conditions Support of the operations of antisubmarine forces: —forecast of hydrological conditions and detection range of hydroacoustic resources —support of the employment of antisubmarine weapons —determination of the maximum distance between hydroacoustic buoys —determination of the optimum running depth of towed sonar
Icy conditions	Information on surface ice conditions for submarines Navigation information

In the United States, the study of the external environment is organized in the framework of the so-called oceanographic program of the naval forces covering five basic disciplines: oceanography itself, hydrography, meteorology, chronometry and astronomy. This article, without diminishing the importance of the other disciplines, takes a closer look at the significance of oceanography for contemporary naval forces. In extending the area of its "vital interests" to the entire globe, the United States is assigning its naval forces the task of being prepared to carry on operations in any region of the world ocean. The latter circumstance also makes it necessary to carry out oceanographic support of the appropriate scope. This becomes possible through the utilization of the global network for interpreting the hydrometeorological situation as well as ship systems for the employment of weapons in their operating radius and for the navigation safety of ships and the flight safety of aircraft.

The existing network of the naval forces for the collection, analysis and distribution of data on the environment makes possible the rapid transmission of received information to the operational combined units in the Atlantic and Pacific theaters of operations.

Reports, forecasts and data on the hydrological and acoustic conditions in the ocean go to the computer center of the naval forces in the city of Monterey (state of California), where large-capacity computers are used to process the current observations for the purpose of comparing them with previously gathered information on the oceanic environment. Then forecasts go to the oceanographic centers of the west and east coasts of the United States, where they are compared with local data of many years of observation. After this, refined forecasts are sent to the command and forces of the navy that require this kind of support.

According to the thinking abroad, there are five basic factors essential for the timely provision of all theaters of naval operations with accurate oceanographic data. They are: scientifically founded forecasting models for the state of the atmosphere and ocean; superfast computers with a large memory capacity; a global data base on the state of the atmosphere and ocean; highly qualified personnel; and effective lines of communication.

Specialists of the U.S. Naval Forces acknowledge that the obtaining of oceanographic data on a global scale is a weakness in the interpretation of the hydrometeorological situation. This results from the fact that the accuracy of forecasting the state of the environment is directly linked with the size of its area covered by

observations. In the ideal case, to forecast the weather and acoustic conditions in the ocean for a period of from several hours (days) to several weeks, observations must be made no less frequently than once a day in the so-called "grid squares of the net" covering the world ocean. In the absence of such conditions, the naval computer center performs similar work with a significantly smaller number of observations and only for the daily forecasting of the state of the environment.

One of the basic methods that is favored in the collection of information of the environment is the utilization of sensors located on orbital platforms (satellites). They are significantly more efficient than traditional equipment for analogous purposes set up on surface ships and aircraft. This is confirmed in the example of the detection and tracking of mesovortices in the ocean from the satellite SEASAT (Sea Satellite—artificial earth satellite for observation of the ocean), whose importance for antisubmarine forces can hardly be overestimated.

Such a mesovortex is a column of cold or hot water that, in separating from the main flow of the current, moves laterally away from it through the ocean. There are large horizontal gradients of the speed of sound on the borders of the vortices and the axis of the underwater sound channel abruptly changes its position. This results in the formation of favorable conditions for the submarine to evade the enemy's antisubmarine forces by going into the vortex or, on the other hand, to its periphery.

The naval forces have an acute need for knowledge of the exact location of mesovortices and of the directions of their movement (trajectories) as well as for forecasts of the hydrological-acoustic characteristics that must be taken into account as a result of the vortex effect. This can be done most efficiently with the help of satellite observations. As shown by test results, the productivity of satellite observations in some regions of the world ocean is more than 10 times greater than of those carried out by conventional means (from ships, aircraft and automatic maritime buoy stations). Figure 1 presents for comparison actual data from a 24-hour period of observations of the surface wind of the ocean taken in 1978 by conventional means and with the help of SEASAT.

In the opinion of foreign specialists, the following remote satellite sensors of oceanographic information are most interesting for the naval forces: microwave radiometer, infrared detector, radar altimeter and scatterometer. Their capabilities are presented in Table 2.

Table 2. Capabilities of Remote Satellite Sensors of Oceanographic Information

Information Sensors	Sensor Capabilities
Microwave radiometer	All-weather measurement of the temperature of the ocean surface globally
Infrared detector	Infrared depiction of the actual state of the ocean surface isotherms (it appears possible to detect temperature fronts and vortices)
Radar altimeter	Determination of the rise or fall of the level of the ocean (it appears possible to identify hydrological fronts and their boundaries)
Radar scatterometer	Measurement of the magnitude and direction of the wind near the water to predict the change of the ocean surface temperature on a global scale

Figure 1. Actual Observations of the Surface Wind of the Ocean During a 24-hour Period by Regions of the World Ocean

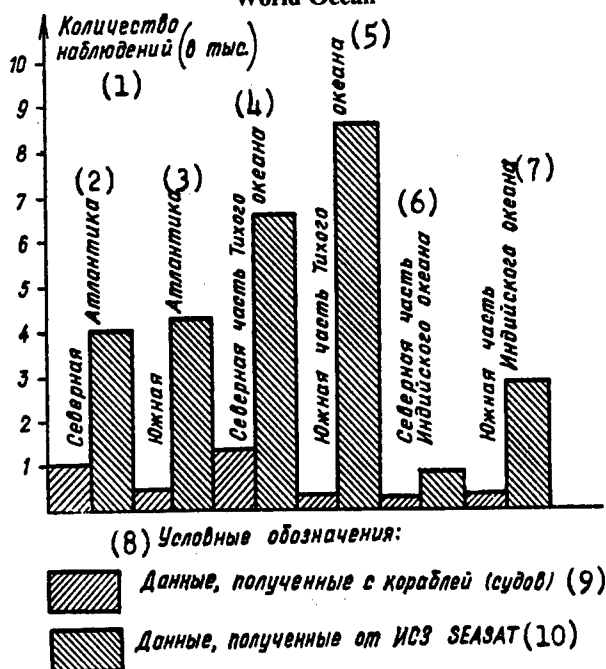

- Key:
- Number of observations (in thousands)
 - North Atlantic
 - South Atlantic
 - North Pacific
 - South Pacific
 - Northern Indian Ocean
 - Southern Indian Ocean
 - Legend
 - Data obtained from ships
 - Data obtained from the SEASAT satellite

At the same time, because of inherent limitations, not one of the types of sensors can independently give a complete picture of the state of the environment under study. Only their combined use will make it possible to expand significantly their capabilities for the collection of data on the atmosphere and ocean on a global scale and to analyze the received information with better quality.

The employment of oceanographic satellites makes it possible to obtain information on the water environment

basically over the surface of the ocean or in its thin surface layer. This, however, is insufficient to support the operations of antisubmarine forces. It is necessary to know the hydrological-acoustic structure of the ocean to a depth of 500 to 1,000 meters and more in the future. This has become possible with the development of the qualitatively new investigatory methods realized in acoustic tomographic systems.

The theoretical bases of the method of acoustic tomography were proposed in 1976 and tested in practice in 1981 and 1983 in the Atlantic test range. The method is based on the dependence of the time for the propagation of the acoustic signal upon the change in the hydrological and acoustic conditions of the environment (temperature, salinity, speed of the current, and so on) as it passes through different layers of the ocean between the source and the receiver (Figure 2).

Two types of systems for acoustic tomography have now been developed: direct and reciprocal. The first is based on the measurement of the time of passage of the acoustic signal traveling on different trajectories from the source to the receiver and on its comparison with the time of passage in an undisturbed so-called "average layer" determined for the period of the operation of the system as a result of quasi-simultaneous measurements by special probes and autonomous oceanographic stations. The obtained changes mainly characterize temperature fluctuations in the ocean. The basis of the second type of tomographic systems is the principle of measuring the difference in the time for the propagation of the sound between the source and receiver in the direct and reverse directions, which makes it possible to determine the elements of ocean currents in the route of changes in the region under study.

The tomographic systems make it possible not only to evaluate the spatial distribution of hydrological-acoustic parameters in the ocean but also to determine the presence of mesovortices and hydrological fronts as well as their elements (width of the frontal zone, depth of penetration and speed of rotation of vortices, type of curve of the vertical distribution of the speed of sound, and a number of others). It is important to know this in planning and carrying out operations of the naval forces, especially antisubmarine operations.

Figure 2. Principle of the Method of Acoustic Tomography

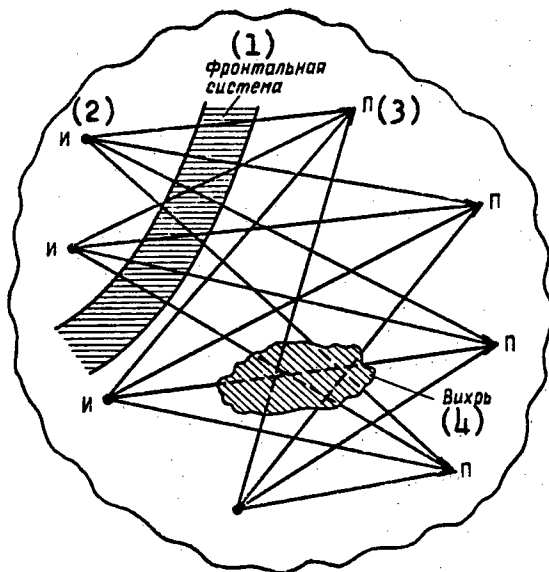

Key:

1. Frontal system
2. Emitter
3. Receiver
4. Vortex

The applied aspects of the use of tomographic acoustic systems for military purposes may include the following:

—provision of the naval forces command agencies with real-time operational information necessary for the efficient resolution of the tasks in the engagement of enemy submarines;

—provision of the fleet oceanographic centers with information necessary for the preparation of hydrological forecasts with their subsequent delivery to the command agencies naval forces;

—accumulation of hydroacoustic information for the establishment of a data bank on specific large regions of the world ocean;

—acquisition of data on deep currents in large water areas of the ocean;

—determination of the boundaries of large-scale nonuniformities, trajectories of movement and the speed of their change of position in the ocean as well as the boundaries of hydrological fronts;

—resolution of several other special tasks (e.g. preparation of charts of noise sources necessary for the effective functioning of the system for the interpretation of the underwater situation and the pronounced increase in the capabilities of antisubmarine forces).

Tomographic systems are local in their spatial coverage; their typical horizontal scale does not exceed 1,000 meters. For this reason, it is planned to deploy them in operationally important regions—at antisubmarine barriers, for example. The received information can reach the computer center of the armed forces by underwater cable or through satellite communications channels for further processing as appropriate.

As the foreign press points out, taking into account the latest achievements in the development of numerical models of the ocean, the existence of superfast computers, and the potential capabilities for observation of the ocean environment with the help of oceanographic satellites and tomographic systems, it can be expected that in the next decade the indicated elements will be combined into a single comprehensive global system for forecasting the state of the ocean.

During the time of military operations, according to Western experts, the system of oceanographic support presented above can be disrupted through the combat effect of the enemy. In this case, the necessary information on the environment will be acquired directly on board the ship. At the present time, a number of systems (ASRAP, SHARPS, ICAPS, NEDS, DTSR, DRAPS, TESS) have already gone into operation on ships or are being developed, systems that utilize data through the direct measurement of the parameters of the environment or obtained from other sources for the immediate forecasting of the hydrometeorological conditions in the region where the operations are carried out. These systems give the command of combined combat units the necessary information permitting the performance of the appropriate calculations for the use of weapons as well as equipment and facilities. In other words, the forecasting information on the environment is organized so that it is accessible at any time, especially at moments when the employment of weapons will be most effective. In so doing, consideration is given to the means of their utilization and to the time and specific nature of the place where the operation is carried out.

The most complete of the indicated systems is the ship tactical system for the provision of data on the environment (TESS), which is expected to be operational at the end of the 1980's. It is intended for the simultaneous processing of local and remote data on the environment, displayed on request, for the purpose of the formulation of hydrometeorological forecasts on its state in the region of the combat operations. In the first stage of operation under the TESS system, it is planned to

automate the most difficult manual methods of the collection, analysis, transmittal and display of data on the environment as well as the formulation of hydrometeorological forecasts.

Oceanographic support in the U.S. Naval Forces is viewed as an important element contributing to a marked increase in the efficiency of the conduct of naval combat operations, especially in remote regions of the world ocean. At the same time, the status of the oceanographic program of the naval forces is now rated on the same level as arms programs and the space program.

The development of naval weapons, the improvement of the methods for carrying out naval operations, and the maximum utilization of the enormous resources of the water expanses is not possible without resolving the problems involved in significantly increasing knowledge of the "three-dimensional environment" of the ocean.

The realization of the plans for further expansion of the system for operational oceanographic support will fully permit a substantial development of the capability of the naval forces as an instrument in the aggressive policies of the leading circles of the United States.

COPYRIGHT: "Zarubezhnoye voyennoye obozreniye", 1988.

Modernization of the TACAMO Very Low Frequency Reserve Communications System
18010239i Moscow ZARUBEZHNOYE VOYENNOYE OBOZRENIYE in Russian No 9, Sep 88 (signed to press 7 Sep 88) pp 49-52

[Article by Ret Lt Col O. Moiseykov: "Modernization of TACAMO Very Low Frequency Reserve Communications System"]

[Text] The U.S. Armed Forces are paying considerable attention to the improvement of the systems for combat command, including of strategic offensive forces, one of the components of which is nuclear-powered ballistic-missile submarines (SSBN's). The SSBN command system must fully meet such requirements as stability, efficiency, flexibility, reliability and undetectability.

The SSBN combat command is implemented through a stationary command system, the basis of which is made up of coastal communications centers transmitting in the very low frequency waveband. To communicate with SSBN's, they also use an abbreviated version of the "Seafarer" communications system operating in the extremely low frequency band (40-80 hertz) and satellite communications systems. A shortcoming of the "Seafarer" system is the low transmission speed measured in minutes, which does not allow timeliness in the transmission of a large volume of messages. The system can therefore be utilized for the transmission of short signals only. The coastal transmitting centers are equipped with huge antenna systems up to tens of

kilometers in length. They are very vulnerable to enemy strikes and their failure will lead to the disruption of the command and control of the SSBN's on combat patrol. The satellite communications system makes it possible to transmit voluminous messages at adequate speed but submarines can receive them only in a surface position or by coming to the surface, which can lead to the detection of the SSBN.

It is thought that the air reserve system TACAMO (Take Charge and Move Out) established back in the 1960's may become the basic system for the command and control of nuclear-powered missile submarines under the conditions of a general nuclear war. At the present time, the system is based on EC-130Q communications relay aircraft. They are equipped with a system of radio receiving and transmitting apparatus that includes a transmitter and a towed antenna intended for the transmission of messages in the very low frequency waveband, primarily signals for the launch of ballistic missiles against nuclear-powered missile submarines. These messages are received by the SSBN's in the underwater mode through a towed floating or buoy antenna at a depth of up to 15 meters.

Communications are ensured in the following manner. The communications relay aircraft flies in a closed circle with a lowered towed antenna in a position close to vertical, which is accomplished through an aerodynamic load attached to its end. The outlined figure reminds one of an aircraft with truncated cone at the base of which is the aircraft with the aerodynamic load at the apex. Effective communications require that the antenna not deviate from the vertical by more than 30 degrees, for it is the vertical polarization of the radio signal transmitted in the very low frequency waveband (14-30 kilohertz) that ensures its penetration into the water.

The TACAMO system is an integral part of the so-called "minimal essential communications channels under the conditions of an extreme situation" for the control of strategic signals under the conditions of a nuclear war. The receiving communications resources of the onboard system receive messages from the coastal communications centers of the naval forces, air command posts of the Joint Chiefs of Staff, the Strategic Air Command, and the commanders in chief of the U.S. Armed Forces in the European, Atlantic and Pacific Ocean zones. The received messages are classified and made available to the information-display devices and those of them that are intended for transmission to the SSBN's are relayed after amplification.

The EC-130Q "Hercules" relay aircraft (16 units) are brought together in two squadrons (3rd and 4th), which are part of the air forces of the Atlantic and Pacific Ocean fleets based at Patuxent River (state of Maryland) and Barbours Point (island of Oahu, Hawaiian Islands) air bases, respectively. From the end of the 1960's to the beginning of the 1980's, the relay aircraft of the 4th

Squadron were on continuous 24-hour duty in the air. In the period from July 1968 to June 1984, they carried out 19,000 flights to different regions of the Atlantic.

The establishment of the new "Trident" submarine-launched nuclear missile system required the renewal of the system for their command and control, including the TACAMO system. The primary reason for this was the fact that an SSBN of the "Ohio" class will operate in more extensive regions than the submarines of the "Poseidon" system and this means that the new relay aircraft must have a greater range, speed and endurance. The basic tactical specifications of the EC-130Q "Hercules" aircraft are: range 7,500 km, maximum speed 600 km/hour, total endurance 10.5 hours, and duration of stay in the duty region about 7 hours (if it is at a relatively short distance from the mission base). At the beginning of 1989, however, the service life of half of the aircraft of this type now in operation will run out.

The study of the question of the replacement of the EC-130Q "Hercules" aircraft began in 1976, when the lead SSBN of the "Ohio" class was laid down. After examining several versions, the choice was made of the airframe of the Boeing 707. It best met the demands placed on the relay aircraft—it had high speed, a long range and endurance, and good flight characteristics. Also playing a role was the fact that the airframe of this aircraft already had protection against an electromagnetic pulse and air cooling. In addition, its production had already been perfected, which made it possible to reduce costs.

The new relay aircraft was given the designation E-6A "Hermes." The construction of an experimental model began in 1983 and flight tests of two aircraft have been under way since the end of 1986. The test program is intended to take 1.5 to 2 years. It is planned that delivery of series aircraft will start at the beginning of the 1990's. Altogether it is planned to build 15 E-6A aircraft (the basic tactical and technical specifications of the aircraft are given below).

Maximum takeoff weight, tons.....	155
Airspeed, km/hour:	
Maximum.....	972
Cruising at an altitude of 12,200 m.....	825
Service ceiling, meters.....	12,810
Flight altitude in combat duty, meters.....	7600-9,150
Range fully fueled without refueling in the air, km.....	12,400
Endurance, hours:	
Without refueling in the air.....	16.5
Refueled once.....	32.5
Maximum with several refuelings.....	72.0

Time in the region of combat duty 1,850 km from the base, hours.....10-11

Length of the aircraft, meters46.61

Height, meters12.93

Wingspan, meters44.42

Area of the wing, square meters283.4

It is also expected that at this time there will still be about 10 EC-130Q "Hercules" aircraft in operation. Work is now under way to develop systems to protect them against the electromagnetic pulse of a nuclear explosion.

With few exceptions, the communications equipment in the E-6A aircraft is the same as in the EC-130Q. It includes three AN/ARC-182 two-way radios of the meter and decimeter wavebands that permit the support of encrypted radiotelephonic communications, two short-wave AN/ARC-190 transceivers, a post for ultrashort-wave satellite communications, receiving equipment for the ERCS system for communications in extreme circumstances, linear encrypting equipment, and teletypes. The aircraft's primary means of communications is the AN/USC-13 transmitter with a power of 200 kilowatts intended for the transmission of signals to nuclear-powered missile submarines. The aircraft is equipped with two towed very low frequency antennas. The main one of the two is unrolled from the central part of the tail section and has a length of 7,925 meters. The aerodynamic load weighing 41 kg attached to its end gives it a vertical position. The total weight of the antenna with the load is 495 kg. The second antenna with a length of 1,220 meters is unrolled from the aft section of the fuselage and serves as a dipole. All of the communications equipment is controlled from a single console in the communications compartment located in the middle part of the fuselage (see diagram). By the mid-1990's, it is planned to install in the E-6A's a more up-to-date amplifier of very low frequency signals, new shortwave and ultrashort-wave receivers and satellite communications equipment as well as computer equipment and a light-weight very low frequency antenna.

In addition, the aircraft is equipped with a weather radar, a radio altimeter, an inertial navigation system, the receiver of the "Omega" navigation system, and analog-digital computer equipment for flight control. The capacity of the E-6A is twice that of the EC-130Q, which provides better conditions for accommodating the equipment and crew (14 men).

The aircraft has a special compartment where the crews can rest. It is located in the nose section of the fuselage immediately behind the cockpit. Up to eight people can rest in it at one time. The nose section of the fuselage also has compartments for the storage of provisions and for the preparation and consumption of food. The tail

Location of the Equipment on the E-6A "Hermes" Aircraft of the TACAMO System

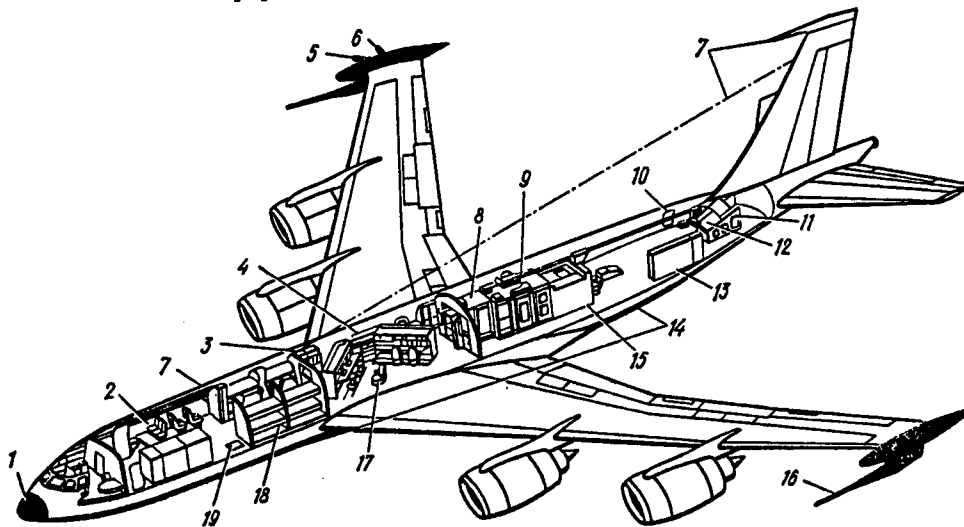

Key:

- | | |
|---|--|
| 1. Weather radar | 11. Dipole antenna winch |
| 2. Crew rest compartment | 12. Very low frequency dipole antenna |
| 3. Linear encryption equipment | 13. Shelves for spare parts and parachutes |
| 4. Central communications console | 14. Radio altimeter antennas |
| 5. Receiving antenna for satellite communications | 15. Very low frequency antenna winch |
| 6. Post for warning against radar irradiation | 16. Shortwave receiving antenna |
| 7. Shortwave transmitting antennas | 17. Communications compartment |
| 8. Terminal equipment (teletypes) | 18. Sleeping places |
| 9. Very low frequency transmitter | 19. Entrance hatch |
| 10. Emergency exit | |

section of the aircraft has shelves for spare parts for different equipment. The aircraft is equipped with a system for replenishing the fuel supplies in the air. By refueling in the air, the total endurance can be extended to 72 hours when a relief crew and the necessary spare parts are on board the relay aircraft.

At the present time, the combat cycle for the utilization of the relay aircraft of the TACAMO system lasts 2 weeks. Each cycle begins with the takeoff of the aircraft from the assigned air base and ends with its return. The relay aircraft use different air bases during the 2-week deployment to increase the viability and stealth of their actions. With the rearmament of the squadrons with the E-6A "Hermes" aircraft, by and large it is proposed to retain the existing mode of their combat employment, that is, 24-hour combat duty, when at any time of the day or night at least one relay aircraft is in the air over the Atlantic and Pacific oceans, a second aircraft is on 15-minute ground alert and a third is on 1-hour ground alert. The remaining aircraft will be at the assigned bases for routine servicing and maintenance. In contrast to the EC-130Q aircraft, the E-6A's will have the possibility of receiving signals in the emergency warning channels while in the "ground alert" position.

Along with the established system for combat duty, in which the aircraft receives and relays signals intended for the missile submarines in the same region, it is planned to make use of a version in which the aircraft can receive a signal in one region and relay it to another.

It is proposed to gradually redeploy the relay aircraft of the 3rd and 4th squadrons from the assigned air bases Barbers Point and Patuxent River to Tinker Air Force Base (near Oklahoma City in the state of Oklahoma). After they have been brought up to full strength with E-6A's, six or seven aircraft will be permanently located at Tinker Air Force Base.

The contract for the production of the E-6A "Hermes" aircraft was awarded to the Boeing Company. Rockwell International is doing the work of manufacturing the sets of communications equipment for them. Such firms as Electrospace Systems and Teledyne are taking part in them. The total cost of the program to modernize the TACAMO system will be approximately \$2 billion.

COPYRIGHT: "Zarubezhnoye voyennoye obozreniye", 1988.

Japanese Naval Aviation

18010239j Moscow ZARUBEZHNOYE VOYENNOYE OBOZRENIYE in Russian No 9, Sep 88 (signed to press 7 Sep 88) pp 52-59

[Article by Capt 1st Rank R. Fedorovich: "Japanese Naval Aviation"]

[Text] The first part of the article¹ examined the organizational structure, composition and deployment of naval aviation in Japan. Based on foreign press materials, information is presented below on the aircraft pool and the prospects for its development.

At the present time, the aircraft pool is represented by 12 types of aircraft and 10 types of helicopters of different

tasking designations. The tactical and technical specifications of the basictypes are presented in the table.

The base patrol aircraft P-3C "Orion," developed by the American firm Lockheed on the basis of the passenger liner "Extra," is produced under license as the basic combat aircraft of the base patrol aviation by the Kawasaki dzhukogyo [transliteration] company and its sub-contractors. The inside volume of its fuselage is divided into two parts—a pressure-tight section (in the upper part) and an unsealed section (in the lower part). The first includes the cockpit and the compartments of the operators with control consoles and different onboard equipment and the second has the weapons bay, 48 rocket launchers for rocket-propelled depth charges, and

Tactical and Technical Specifications of the Basic Aircraft and Helicopters of the Japanese Naval Forces

Specifications	Aircraft					Helicopters			
	P-3C	P-2J	PS-1	U-36A	SH-60J	HSS-2B	MH-53E	V-107A	
Weight, kg:									
Empty aircraft (helicopter)	27,900	19,300	26,300	4,400	6,200	4,500	15,100	5,900	
Maximum takeoff	64,400	34,000	45,000	8,900	9,000	9,300	33,300	9,700	
Air speed, km/hour:									
Maximum	760	400	540	870	300	270	310	270	
Cruising	610	370	410	770	250	220	280	-	
Service ceiling, meters	9,000	9,150	8,900	13,700	5,700	4,500	5,600	4,200	
Operating radius, km	3,100-4,000	-	2,400	-	160	-	-	-	
Ferrying range, km	7,600	4,500	4,700	5,000	600	1,000	2,100	390	
Takeoff distance (to a height of 15 meters), meters	1,670	1,100	300	-	-	-	-	-	
Landing distance (from a height of 15 meters), meters	845	880	200	930	-	-	-	-	
Dimensions, meters:									
—Length of fuselage	35.6	29.2	33.5	14.8	15.3	16.7	22.3	13.7	
—Wingspan*	30.4	31.7	33.1	12.1	16.4	18.9	24.0	15.2	
—Height	10.3	8.9	9.7	3.7	5.2	5.2	8.7	5.1	
Maximum payload, kg	6,000	3,600	4,000	1,360	-	-	16,000	3,000	
Size of crew	10	12	10-12	4	3	4	3	6	

*For helicopters, diameter of the main rotor.

other auxiliary equipment. The project foresees leaving 25 percent of the useful area of the fuselage free for accommodating prospective systems for the search for and detection of submarines. The endurance was increased through the volume of supplemental internal fuel tanks. The aircraft has a crew of 10—the pilot and copilot, the flight engineer, the coordinator of the tactical situation, two operators of the hydroacoustic equipment and an operator of the nonacoustic equipment, the operator of the navigation and communications equipment, and two observers.

The armament is located in the fuselage compartment (dimensions 2.0 X 0.8 X 3.9 m) and on 10 external underwing pylons. Depending on the nature of the tasks being resolved, the P-3C can load different types of weapons in the following versions: eight 157-kg depth bombs of Type 67 in the fuselage compartment, eight antisubmarine torpedos (Mk44, Mk46 or Type 73), one mine of the 2,000 pound caliber (Mk55 or 56), three mines of the 1,000 pound caliber (Mk52); the underwing pylons carry up to four "Harpoon" underwing cruise missiles, torpedoes, mines and air-launched rockets.

The aircraft is equipped with an up-to-date operational information-command antisubmarine system A-NEW, rocket-propelled depth charges, and other American electronic equipment. Several instruments of domestic development are also installed in the Japanese P-3C aircraft (the communications equipment HRC-112, HSC-11, -12 and -14, and RCC-22; the navigation equipment LTN-72, HRN-101B and -107, HPQ-2, R-1651/ARA; the acoustic recording equipment N-RO-40/HMH and N-1D-128A; the identification equipment CV-2461A/A and the weapons-utilization equipment BRU-12A, -14A and -15A).

The basic element of the A-NEW system is the general-purpose AN/ASQ-114 (V) digital computer. It has a speed of response of 3 million operations/second and 16 channels for the input (transmission) of information from various subsystems. In addition, A-NEW includes the AN/AYA-8B equipment for the processing, analysis and transformation of data linked with the computer, consoles of the pilots and operators, and peripheral electronic subsystems. It permits the automation of the processes of the search for and detection of submarines and surface ships as well as the employment of weapons. To a significant degree, this frees the crew from labor-intensive operations and makes it possible to concentrate one's attention on the performance of the combat mission. The A-NEW processes and analyzes different data from the detection gear (radar, rocket-propelled depth charges, "radiotechnical" intelligence set, and the like), displays them and automatically transmits them to other aircraft, ships and coastal stations (ASWOC posts). In particular, it determines the current coordinates of the aircraft (utilizing the information of the "Omega" radio navigation system), targets and buoys, selects the type and releases the rocket-propelled depth charges at the assigned point, and accounts for their consumption. A-NEW allows pilots to take the aircraft to the point of interception with the target and to work out commands for the automatic employment of weapons. On request the crew members can receive on their displays information on the depth of the sea, the nature of the bottom, salinity and temperature at different water levels, swells, wind and so on. In addition, this system warns the operator of his incorrect actions, provides for communications between crew members through the computer and electronic display subsystem, regulates itself and determines the location of defective assemblies and the type of breakdown.

The A-NEW system makes use of microelectronic circuits and interchangeable assemblies that can be easily checked and serviced. Up-to-date elements of modular electronics are widely used. According to the foreign press, the mean time between failures in the A-NEW system is 1,000 hours and 10-15 minutes are needed to correct most failures.

The radiohydroacoustic buoys are the basic means in the search for and detection of submarines. The Japanese P-3C aircraft utilize active AN/SSQ-47B rocket-propelled depth charges of unguided action and passive

AN/SSQ-53B's of the "Difar" system. The distribution spectrum of the levels of sea noises is determined with the help of special buoys of the type AN/SSQ-57. The dimensions of most buoy types are standard.² As many as 87 buoys of different types can be accommodated in the P-3C aircraft. They are released with the help of launcher tubes that contain a powder charge ignited by an electric circuit. Forty eight such launcher tubes (each for one rocket-propelled depth charge) are loaded in the lower unsealed part of the fuselage immediately before takeoff. Four launchers for the remaining buoys are located in the upper, pressure-sealed part of the fuselage. They are loaded during flight only. The selection of the buoy type is made in accordance with the mission that the crew is to carry out. The specifications of each buoy are input in the computer so that it can be released automatically at the necessary point in the flight under a set program.

The cockpit is equipped with two control consoles. The console of the ship commander has a display of the tactical situation in real time, where the initial and expected coordinates of the target, location of the aircraft and route of flight to the predicted position, and coordinates of the released rocket-propelled depth charges are displayed. Data on the air speed, estimated time of arrival at the air base or assigned patrolling region and distance traveled. With the help of a keyboard, the commander can communicate with the computer, main display of the tactical situation, and other electronic subsystems. In the cockpit, there is also an auxiliary display of combined aircraft performance data of the altitude, course of the aircraft and flight to the predicted position. The computer monitors the employment of weapons but the commander can take manual control at any moment.

The post of the coordinator of the tactical situation is equipped with an AN/ASA-70 console with data display. It presents information on the situation, precise time, wind speed and direction, distance traveled, course and speed relative to the ground. All data are calculated automatically, put on magnetic tape during the flight and analyzed after landing. The operator utilizes an auxiliary display for the representation and read-out of data that have been input into the computer memory unit. With the help of the console keyboard, he can compose and transmit reports through the printing channels. The speed of information transmission is 60 to 100 words per minute and the computer print-out speed is 3,000 [words per minute]. Two-way communication with other P-3C aircraft, surface ships and coastal stations is maintained through the "Link-11" transmission line for digital data.

Two posts for operators of hydroacoustic apparatus are equipped with means to control and monitor rocket-propelled depth charges: AN/AQA-7 (V), AN/AQH-4

(V), AN/ARR-72 (V) and AN/ASA-76A. AN/ASA-66A displays are used to represent data.

The post of the operator of nonacoustic apparatus is equipped with instruments for the control, monitoring and display of information received from the AN/APS-115B radar, AN/ASQ-81C magnetic detector, AN/AAS-36 infrared reconnaissance station and AN/ALQ-78 station for radio and electronic reconnaissance as well as the radar transponder and interrogator AN/APX-72 and -76 (V) and the display devices AN/ASA-64A and -65 (V).

The post of the operator of the means of radio communication and navigation is equipped with the shortwave and ultrashort-wave radio sets AN/ARC-161, HRC-112, AN/ARC-143B as well as with the communications encryption devices HSC-11, -12 and -14 and other communications equipment: AN/ACQ-5A, AN/AGC-6, RRC-22, AN/AIC-22 (V). The inertial navigation system LTN-72 gives out data on the position of the aircraft, course and altitude throughout the flight. The doppler navigation radar AN/ARN-227 makes it possible to calculate the drift of the aircraft and its speed relative to the ground. Information from the navigation system is fed into the computer, which also generates data on the absolute altitude of the aircraft.

Two observation posts are located near the side windows and are equipped with means of visual observation. The observers can replace operators if necessary.

The base patrol aircraft P-2J was developed by the Kawasaki dzhyukoye [transliteration] firm in the 1960's based on the American P-2V7 "Neptune." It is a monoplane with a straight wing located in the middle, a single-fin tail assembly and four engines. The all-metal fuselage is of the monocoque type and the length of the forward section has been extended by 1.27 meters (compared with the fuselage of the P-2V7), making it possible to accommodate supplementary electronic equipment.

In the event of an emergency landing on water, the aircraft can remain afloat for some time. There is an anti-icing system for the leading edge of the wing and for the tail assembly.

The aircraft's power unit is composed of two T64-IHI-10E turboprop engines with a shaft horsepower of 3,060 each, which turn three-bladed all-metal propellers with a diameter of 4.4 meters, and two J3-IHI-7D turbojet engines with a maximum thrust of 1,550 kg each. The engines are manufactured by the Japanese firm "Ishikawajima-Harima" (turboprop engines under American license).

The fuel is located in the internal fuselage and wing tanks with a total capacity of 11,430 liters. Additional tanks for 760 liters each can be mounted on the wing tips. In the ferrying version, there is another supplementary fuel tank for 2,650 liters in the weapons bay.

The landing gear of the P-2J is retractable with three struts. The front strut is controllable and the main struts are retracted forward into the engine nacelle. They each have two wheels 100 X 33 cm in size and the tire pressure is 7 kg/cm². The front strut is retracted to the rear, its wheels are 86 X 25 cm, and the tire pressure is 6.3 kg/cm².

Two independent hydraulic systems driven by the engines are installed in the aircraft. The primary hydraulic system (pressure 207 kg/cm²) is intended for the lowering and retraction of the landing gear and the auxiliary system (104 kg/cm²) provides for the work of the systems of the high-lift devices, doors of the engine nacelle, brakes of the main landing gear struts, and other mechanisms.

The power supply system is composed of two generators of alternating current (power 40 kilowatts, voltage 115/220 volts and frequency 400 hertz) and three direct-current transformers (voltage 28 volts, strength of current 200 amperes).

The armament is located in the fuselage compartment and on underwing pylons. The P-2J aircraft can load 16 depth bombs, 4 torpedoes as well as mines and 8 obsolete 127-mm and 55-mm air-launched rockets. The antisubmarine equipment includes an AN/APS-80 search radar, active "Julie" and passive "Jezebel" rocket-propelled depth charges, a magnetic detector, a searchlight, and an HSA-116 tactical situation display.

The navigation equipment is represented by the AN/APN-187B doppler radar, an N-PT-3 navigation display, an N-OA-35/HSA display of the tactical situation, the apparatus of the TACAN short-range navigation and LORAN long-range navigation systems, a radio altimeter, an instrument-landing system and a PB-60J autopilot. The communications equipment includes an intercom, shortwave and ultrashort-wave radio sets, a teletype, communications encryption apparatus, and an encryption device.

The crew of the P-2J is comprised of two pilots in the cockpit, seven operators of onboard equipment in the tactical compartment (behind the cockpit) and three operators in the weapons bay (central part of the fuselage behind the wing). There are emergency hatches in the cockpit and in both compartments.

The base patrol hydroplane PS-1 with a shortened take-off and landing was developed by the Japanese firm "Sin Meyva" at the end of the 1960's.

The aircraft structure represents an all-metal monoplane with a high wing and a T-shaped tail assembly. The fuselage is of the semimonocoque type and the bottom part is gliding. Because of its form as well as the presence of grooved damping devices and splash suppressors, the hydroplane does not create a big wave in landing on the water and can take off and land on the surface of the

water with waves up to force four. Structurally the fuselage is divided into upper and lower decks. There are stabilizing pontoons on the arms at the ends of the wings. The tail assembly and wings are outfitted with an anti-icing system for the leading edge.

The power unit is made up of four T64-IHI-10E turbo-prop engines each with 3,060 horsepower having reversible three-blade propellers with a diameter of 4.4 meters. These propellers improve the maneuverability of the aircraft, providing for rapid braking and turning. In addition, there is a T58-IHI-10 gas-turbine engine with 1,400 horsepower in the central part of the fuselage for driving the compressor of the system for controlling the boundary layer. The lift of the wing was increased by air flow over the flaps, rudder and elevator, which made it possible to shorten the takeoff and landing distance.

The fuel is stored in five wing tanks and two tanks in the tail section of the fuselage (total capacity 19,520 liters). The hydroplane is equipped with a three-wheel rolling landing gear, which can be utilized while parked on the airfield and when descending to the water.

The aircraft has two independent hydraulic systems (pressure 207 kg/cm²) for driving the lift-augmentation devices and various mechanisms as well as a system to air condition the cockpit. The auxiliary power unit GTC P85-131J is utilized for starting up the engines and driving the emergency generator. The electric power system is composed of two primary generators and one emergency generator of alternating current each with a power of 40 kilowatts.

The weapons bay, in which up to four depth bombs of Type 67 and smoke charges can be suspended, is located in the upper deck. There are two torpedoes Mk44 or of Type 73 under each wing panel and three 127-mm air-launched rockets on the end of each wing.

The antisubmarine equipment is composed of a magnetic detector, lowerable sonar, 20 passive "Jezebel" rocket-propelled depth charges, 30 active "Julie" buoys, search radar and a console with a screen for displaying the tactical situation. In addition, the aircraft has a radio compass, receivers for the short-range navigation system TACAN and for the long-range system LORAN, a device to determine the height of waves, a doppler radar, a plotter of navigation data, a navigation plotting board, communications equipment and an HLR-1 electronic surveillance station. A searchlight is mounted under the right wing panel.

In the right section of the tactical compartment are electronic equipment, a magnetic detector and hydroacoustic equipment and in the left is a place where the crew members can rest. The lower deck from the nose to the tail sections of the fuselage is occupied by a compartment for electronic equipment, niches for oxygen cylinders and the main struts of the landing gear and two fuel tanks.

The crew includes two pilots and a flight engineer, two operators of hydroacoustic equipment, a navigator, operators of the magnetic detector and search radar, a radio operator, a tactical coordinator and two observers.

The Japanese command decided to procure the up-to-date aircraft EP-3J and U-36A to replace the obsolete electronic warfare and combat training aircraft UP-2J and -2JE. The EP-3J's will replace the UP-2JE's in 1990-1991. They will be built under American license by the Kawasaki company on the basis of Lockheed's EP-3E. The basic tactical and technical data of these aircraft do not differ significantly from those of the P-3C. Instead of an antisubmarine set, their onboard equipment will include different means of electronic warfare and radio and electronic reconnaissance (some of the equipment on the EP-3J was developed by the Japanese).

The U-36A aircraft for electronic warfare and combat training were developed in Japan under the TS-X program utilizing the air frame of the jet passenger liner "Leerjet-36A" of the American firm Gates. The Japanese installed onboard, towed and launched devices in them for active and passive interference, targets and decoys. In so doing, the crew was increased by two operators. The U-36A's are supposed to replace the UP-2J's.

Japan's antisubmarine helicopters are represented by the types SH-60J³, HSS-2A and -2B. The last two differ insignificantly. They are produced by the plants of the Mitsubishi firm. Their armament and equipment is the same as that of the American helicopter SH-3H "Sea King." The helicopter HSS-2B can carry four torpedoes Mk44, Mk46 Modification 5 and Type 73 or four depth bombs of Type 67 as well as up to 25 rocket-propelled depth charges. The search equipment includes an HPS-102 radar, an AN/AQS-13A lowerable sonar, and an AN/ASQ-81B magnetic detector (V). The onboard means of navigation, communications, information processing and other systems of Japanese helicopters are widely represented by equipment of domestic production: HPN-101 and -105, N-OA-35/HSA, HPQ-1B-2, N-TR-2, N-1-D-66/HRN; HIC-8, HRC-107, -109 and -110B, HSC-10B; HSA-117, HQH-102D, N-RO-20B/HMH, N-PF-6C, N-C-482.

The minesweeping helicopters MH-53E⁴ are greatly superior to the obsolete V-107A's, which were produced by the Japanese firm Kawasaki under American license. The new helicopters are equipped with three shaft-mounted turbine engines T64-GE-416 with a maximum power of 4,380 horsepower each. The tanks (one on each side) each hold 12,100 liters of fuel, which is sufficient for a flight lasting 6 hours. An additional supply of approximately 4,900 liters is stored in suspended jettisonable tanks.

In minesweeping, the MH-53E helicopters can utilize different sweep gear: a mechanical Mk103, an acoustic Mk104, the influence sweeps Mk105 and Mk106, and electromagnetic sweeps, including the new Mk166. They are equipped with a two-channel digital automated control system to support flight and the hovering mode as well as entering and leaving that mode, a display of the tilt angles and tensile stress on the cable (up to 13.6 tons), a system to monitor the aqueous medium, a ramp for the deployment of a mine-detection sonar with lateral scanning, a more complete system for the control and monitoring of sweeping, and other up-to-date equipment.

Basic directions of development. In the future development of the naval aviation, the greatest attention is being paid to the reequipment of the fleet of base patrol aircraft with P-3C "Orion" aircraft, the production of which was organized in 1981 under American license. Appropriations were passed for the construction by the middle of the current year of 78 aircraft (including 9 aircraft of the Update-III modification), 37 of which will join the 1st, 5th and 7th air patrol squadrons in the next 4 fiscal years.

The current 5-year program for naval construction provides for the appropriation of additional funds for the procurement of another 22 P-3C's and it is planned to deliver them to the aviation units by March 1994. By this time, according to foreign press reports, it is expected that the strength of base patrol aircraft, taking into account the writing off of obsolete models, will be 100 patrol aircraft (94 P-3C's⁵ and 6 P-2J's) organizationally grouped in 10 air squadrons. It is thereby planned to station two squadrons each at the air bases Atsugi, Kanoya, Nakha and Khatinoe and one each at Simosa (9-10) and Ivakuni (6 P-2J's and 3-4 P-3C's).

It is planned that base patrol aviation will be further developed in the scope of the next 5-year program for the construction of Japanese naval forces in the years 1991-1995. In particular, they are examining proposals for the procurement of P-3C patrol aircraft of the modification Update-IV, P-3AEW AWACS and control aircraft equipped with AIM-54 "Phoenix" rockets, the advanced ASM-1C and -2 air-launched antiship rockets, the G-RX4 antisubmarine torpedoes and other types of weapons developed domestically.

It is proposed to replace the UP-2JE electronic warfare aircraft with EP-3J's (three are to be procured by 1991). In the future, it is planned to station an air squadron of 9 EP-3J's at the Ivakuni air base. The obsolete UP-2J's are being replaced by the U-36A aircraft for electronic warfare and combat training. Altogether it is planned to acquire six such aircraft.

The fleet of antisubmarine helicopters will be increased to 102 by the spring of 1994. The 21st and 22nd air wings will each have 24 SH-60J deck helicopters (it is planned to order another 24 helicopters in the next 2 years) and HSS-2B's assigned to the ships of the naval escort forces.

It is proposed to include 12 ship helicopters—8 regular and 4 reserve helicopters—in each of 4 (121st, 122nd, 123rd and 124th) air squadrons of these wings. It is proposed to activate the new 124th Air Squadron of the 21st Air Wing at the Tateyama air base in the current fiscal year and helicopters from that squadron will be assigned to the ships of the 4th Destroyer Flotilla. Organizationally it is planned to bring together the HSS-2B shore-based antisubmarine helicopters (54 helicopters) in six separate air squadrons. It is proposed to station them at the air bases Ominato, Tateyama, Komatsushima, Omura, Nakha and Kanoya (8-10 helicopters at each). In the coming years, according to the foreign press, one can expect the appearance of a new separate air squadron at the Nakha air base and the commander of each naval region (except the Maizuru Naval Region) will have a regular squadron of antisubmarine helicopters at his disposal.

It is planned to complete the writing off of the obsolete V-107A minesweeping helicopters by the end of the 1990's with their replacement through the American MH-53E "Sea Dragon" helicopters. With them, it is planned to constitute two separate air squadrons (six helicopters in each squadron).

There are also proposals for the gradual upgrading and replacement of the aircraft and helicopters of the auxiliary aviation of the Japanese naval forces. It is planned to maintain the number of US-1A "Sin Meyva" search-and-rescue hydroplanes at seven through additional procurements to replace those being written off. The KM-2 training aircraft are supposed to be replaced gradually with their improved modification MK-2K by the mid-1990's. It is planned by the beginning of the next decade to replace the obsolete B-65's with LC-90 communications aircraft developed on the basis of the TC-90. Still unresolved is the question of new transport aircraft to replace the old YS-11MA and -TA's that have virtually exhausted their engine mileage.

The question of the prospective HH-X search-and-rescue helicopter, which later on will completely replace the S-61A, is under study. The most probable candidate among the various models is still considered to be the HH-60J⁶ developed on the basis of the SH-60B. As for the training helicopters, it is planned to continue to procure the OH-6D to replace the obsolete Bell-47G and OH-6J.

As noted in the foreign press, the realization of the current aircraft construction programs will make it possible to increase significantly the combat capabilities of Japanese naval aviation while maintaining the overall size of the aircraft fleet.

Footnotes

1. For the beginning of the article, see: ZARUBEZH-NOYE VOYENNOYE OBOZRENIYE, No 8, 1988, pp 47-52.

2. For more details on the electronic warfare aircraft, see: ZARUBEZHNOYE VOYENNOYE OBOZRENIYE, No 3, 1986, pp 56-60; and No 6, 1987, pp 53-57.
3. For more details on them, see: ZARUBEZHNOYE VOYENNOYE OBOZRENIYE, No 5, 1988, pp 57-58.
4. For more details, see: ZARUBEZHNOYE VOYENNOYE OBOZRENIYE, No 11, 1985, p 71; No 5, 1986, p 77.
5. All aircraft of modification Update-III (through additional equipping and modernization of existing aircraft).
6. An analogous search-and-rescue helicopter for the air forces was designated UH-60J.

COPYRIGHT: "Zarubezhnoye voyennoye obozreniye", 1988.

Prospective Automated Ship System of Battle Management for Great Britain's Naval Forces
18010239k Moscow ZARUBEZHNOYE VOYENNOYE OBOZRENIY in Russian No 9, Sep 88 (signed to press 7 Sep 88) pp 59-60

[Article by Capt 2nd Rank V. Seredyushin: "Prospective Automated Ship System of Battle Management for Great Britain's Naval Forces"]

[Text] The command of Great Britain's naval forces contracted with the firms Graham Lion Electronics and CAP Scientific for 85 million pounds sterling for the development and production of a new onboard automated battle management system (ASBM) that was given the designation SMCS (Submarine Command System). According to foreign specialists, the indicated ASBM can be put into operation in the first half of the 1990's. It is proposed that the SMCS be installed on the new SSBN's of the "Vanguard" type, on the nuclear-powered submarine "Trafalgar" and on the "Upholder" diesel submarines. It is also possible that the system will be sold to other countries. In particular, Canada and Sweden are showing interest in it.

The automated system SMCS represents a local computer network in modular form that puts into effect the concept of the distributed processing of data. The local computer network of this system has 11 nodes linked with the help of a dual optic-fiber data transmission line (VOLPD) with a large bandwidth. The network nodes are: five multifunctional operator consoles, including the commander's console with a display of the tactical situation; two extension terminals in the room of the sonar specialists; two input-output stands; and two service nodes with processing and memory units for large

data files. The SMCS processes all data with the help of more than 100 32-digit processors 80,386 of the firm Intel linked with the Multibus-2 protocol through the VOLPD nodes.

Among the new technological solutions used in the establishment of the ASBM under consideration are:

—T800 microprocessors-transputers of the firm Inmos. They provide for a high degree of parallelism in the computing and processing of information and make it possible to increase the processing speed by a factor of approximately 20 (in comparison with the version of traditional sequential work). The T800 represents special processors with the principle of RISC (Reduced Instructions Set Command) built into their program that include the means for parallel work and the performance of a series of operations. In the SMCS system, the microprocessors-transputers provide for the specialized rapid processing of information in service nodes having an interface and eight processing boards (each of them contains eight transputers) and performing digital work with a speed of about 50 million operations with a floating point per second.

—An optic-fiber data transmission line, an important element of the SMCS. It can provide for interchange between processing elements with a high productivity and has a bandwidth allowing for the reliable exchange of information at a speed of 166 megabits with protection against external induction.

—The high-level programming language ADA. The automated system of battle management SMCS will be the first European ship system for combat functions in which this language is utilized in practice. According to foreign specialists, the software written for ADA will have about 750,000 lines for basic software codes and an equal number in the diagnostics and control programs. The system also utilizes the specialized language OSSAM developed to support transputers.

—Multifunctional operator consoles with polychrome displays that were first used on the ships ASBM's of the British naval forces.

—The unification and standardization not only of the system software but also of the hardware. In particular, in the entire automated system SMCS use is made of 22 types of printed circuit boards, 8 of which are plugged into the processing means.

—The modular principle of the structure and design of the system as a whole. This fully corresponds to the concept adopted in the NATO naval forces of the construction of ships using modules and also makes it possible to assemble an ASBM composed of individual subassemblies and modules, to check it on shore stands, and then to deliver it to the shipyard in special containers with the means of mobile monitoring and to reduce the overall time for installation on the ship. This principle makes it possible to increase the hardware and software in the systems actively.

The automated system SMCS allows for the flexible variation of subassemblies and modules and for this reason the manufacturers are examining the possibility of setting the system up in submarines as well. In particular, in cooperation with the Rekel firm, they are studying a version of a similar ASBM for a guided missile frigate of the "Norfolk" type (Project 35).

COPYRIGHT: "Zarubezhnoye voyennoye obozreniye", 1988.

Military Expenditures of Key European NATO Countries in 1988

180102391 Moscow ZARUBEZHNOYE VORENNOYE OBOZRENIYE in Russian No 9, Sep 88 (signed to press 7 Sep 88) pp 61-69

[Article by N. Voronov, candidate of economic sciences, and L. Borisov under "Military Economy and Infrastructure" rubric: "Military Expenditures of Key European NATO Countries in 1988"]

[Text] During almost the entire 40 years of its existence, the NATO bloc has been the main source of the military danger and arms race in the world. The United States, the leader of this alliance, is actively involving its European partners in the preparation for war with the countries of the socialist community and is subjecting their material and manpower resources to its own interests, forcing them to spend huge sums on militaristic preparations.

According to the journal "NATO's Sixteen Nations," the military expenditures of the bloc countries almost doubled from 1980 to 1987 and reached \$428.6 billion in 1988, whereby the share of the European countries in total expenditures is more than 30 percent. This indicates the large role of the European partners of the United States in joint efforts to increase the military power of the NATO bloc. It was at the plenary session of the West European Union held on the 26th and 27th of October 1987 in the Hague, according to former French Prime Minister J. Chirac, that "the European countries first triumphantly declared their intention to make defense policy a fully valid element of overall European development."

The cumulative annual military expenditures of the European NATO member countries had exceeded \$130 billion by 1987. About 90 percent of these funds are attributed to Great Britain, the FRG, France and Italy.

The budget bill of the Defense Ministry of GREAT BRITAIN for the 1988/1989 fiscal year (it began on 1 April) is for 19.2 billion pounds sterling, which exceeds the level of the previous year by 2.3 percent. The total volume of military expenditures, taking into account the funds allocated for these purposes in the budgets of other ministries and departments, reaches 19.8 billion, and their share of the state budget is 15.2 percent.

As in previous years, more than 95 percent of the funds allocated to the Defense Ministry will be designated for the performance of tasks resolved by the armed forces of Great Britain in the scope of the overall strategy of NATO. The distribution of the Defense Ministry budget in the main programs is represented in Table 1.

Table 1. Distribution of the Defense Ministry Budget of Great Britain in Main Programs (in millions of pounds sterling)

Main Programs	Fiscal Years		Percent Increase Compared With 1987/1988
	1987/88	1988/89	
Strategic nuclear forces*	882	1,072	21.5
General-purpose forces	9,119	9,266	1.6
Reserve armed forces	385	420	9.1
Combat training	1,277	1,249	-2.2
Scientific research and experimental design work	2,337	2,257	3.4
Operation and maintenance of equipment	881	955	8.4
Logistic support and other programs	3,901	3,996	2.4
Total	18,782	19,215	2.3

*SSBN's only

The expenditures for strategic nuclear forces in the current year will be 1.072 billion pounds sterling, which is 21.5 percent more than in the previous year. These funds are intended for the support of four nuclear-powered missile submarines with "Polaris" missiles. In accordance with the plans for the modernization of strategic nuclear forces, it is proposed by the mid-1990's to commission four SSBN's of a new generation

equipped with American "Trident-2" missiles (with British warheads). They are intended to replace the SSBN's armed with "Polaris" missiles. According to official estimates revised every year, the total cost of the "Trident" program will be 9.043 billion pounds sterling, of which 64 percent will be expended to pay for work performed in Great Britain. The remaining funds are intended for procurements in the United States.

In paying a great deal of attention to the modernization and buildup of its strategic forces, the country's military and political leadership is implementing a large number of measures for the development of general-purpose forces. It is planned to expend 9.266 billion pounds sterling in the 1988/1989 fiscal year for their support and upgrading.

The Defense Ministry budget allocates 3.416 billion pounds sterling to the air forces. The basic programs of their technical equipment are procurements of "Tornado" and "Harrier-GR.5" fighters.

The cost of the program to procure "Tornado" fighters in the tactical-fighter and fighter-interceptor versions is estimated at 10.28 billion pounds sterling. It is planned to acquire 244 aircraft under the program; 140 "Tornado" fighters have now gone into operation. Their deliveries will be continued in the current year.

Some 1.23 billion pounds sterling were allocated just for the procurement of the first 62 "Harrier-GR.5" tactical fighters ordered. An additional contract has now been signed for the delivery of another 34 tactical aircraft. Besides these programs, there will also be procurements of "Tucano" combat training aircraft, "Skyflash" guided missiles of the "air-to-air" class and "Sea Eagle" guided missiles of the "air-to-ship" class, and JP233 cluster bombs. It is also planned to acquire the new communications system "Boxer-2" implemented with the use of fiber optics.

Altogether expenditures for the tactical equipping of the air forces will reach 3.075 billion pounds sterling, of which it is planned to spend 628 million for scientific research and experimental design work in the area of aircraft equipment.

The ground forces are being allocated 3.425 billion pounds sterling. More than 67 percent of these resources are intended for the support and equipment of the units of the British Rhine Army and units stationed in West Berlin. It is planned to allocate the remaining funds to the units and combined units stationed in the metropolitan country (about 28 percent) and other regions of the world.

In the scope of the program for procurements of weapons and military equipment, significant resources are being allocated to the acquisition of the "Challenger" tanks,

"Warrior" infantry fighting vehicles, and armored personnel carriers "Saxon," the MLRS multiple rocket launcher, the anti-aircraft missile system "Rapier" and the portable anti-aircraft missile system "Javelin." It is also planned to continue the procurement of large lot of 5.56-mm SA-80 automatic rifles, 51-mm mortars, and LAW-80 antitank grenade launchers. It is proposed to spend significant resources on the acquisition of systems for communications, command, reconnaissance, and protection of personnel against weapons of mass destruction.

The total expenditures for the technical equipment of the ground forces will be 1.56 billion pounds sterling, of which expenditures for scientific research and experimental design work in the interests of this service branch will be 188 million.

The naval forces will be allocated 2.425 billion pounds sterling in the current fiscal year. The largest share of the funds (660 million) will be spent for the procurement, modernization and support of destroyers and frigates. This has to do with the plans of the country's military and political leadership to establish the largest fleet of surface ships in Western Europe. It is proposed to have up to 50 frigates and destroyers in the naval forces. Three guided missile weapons of the "Broadsword" type (Project 22) will become operational in the current year.

Significant resources (431 million pounds sterling) are being allocated for the development of the combat capabilities of the submarine fleet. In 1988, one nuclear-powered submarine of the "Trafalgar" type and the head diesel submarine in the "Upholder" series will become part of the naval forces. In addition, 104 million pounds sterling will be spent for the maintenance and upgrading of aircraft carriers, 100 million for minesweepers and minelayers, 99 million for the ships of the amphibious forces, 428 million for ships and vessels of other classes, and 265 million for naval aviation.

The military preparations in the FRG are financed on the basis of the long-term plan for the development of the armed forces, which determines the basic directions of the development of the Bundeswehr over 15 years. In accordance with this plan, it is planned under the state budget bill for fiscal year 1988 (coincides with the calendar year) to allocate DM51.4 billion to the Ministry of Defense, which is 0.5 billion (1.0 percent) more than in the previous year.

Table 2. Distribution of the Budget of the FRG Ministry of Defense by Specific Designation

Classed of Expenditures	1987 Fiscal Year		1988 Fiscal Year	
	Funds Allocated, Billions of DM	Share of Budget, Percent	Funds Allocated, Billions of DM	Share of Budget, Percent
Combat training, personnel support, maintenance and operation of military equipment	33.8	66.4	34.7	67.5
Procurement of weapons and military equipment	12.0	23.6	11.7	22.8
Scientific research and experimental design work	2.8	5.5	2.8	5.4
Construction of military facilities	2.3	4.5	2.2	4.3
Total	50.9	100.0	51.4	100.0

Taking into account the funds appropriated to civilian ministries and departments for military purposes (military aid to other countries, the pensions of former Bundeswehr servicemen, the support of foreign armed forces in the territory of the FRG, etc.)¹, the total military expenditures of the country will reach DM61 billion (U.S.\$32.8 billion). Their share of the state budget will be 22.2 percent and 3.0 percent of the gross national product.

These funds will be spent for the further upgrading of the combat readiness of the armed forces: improvement of their regular organizational structure, execution of previously approved programs for the procurement of weapons and military equipment and preparation for the fundamental rearmament of the Bundeswehr in the 1990's, intensification of military research for these purposes and concentration of main efforts in the latest technologies, and further improvement of the NATO infrastructure.

To carry out the tasks in increasing the combat capabilities of the armed forces, the Ministry of Defense was allocated DM11.7 billion (22.8 percent of the military budget) in 1988 for the acquisition of weapons and military equipment. The limited reduction in this class of expenditures in the budget of the Ministry of Defense compared with the previous year has to do with the gradual conclusion of programs to deliver basic weapon systems and second-generation military equipment to the forces (Table 3). Thus, for example, expenditures under the "Tornado" program declined by 25 percent compared with 1987 (to DM1.8 billion). At the same time, this makes it possible to begin procurement of new weapon models, in particular in the area of reconnaissance and command. The largest part of the funding for the acquisition of weapons and military equipment in 1988 is aimed at financing the programs for the delivery of "Leopard-2" tanks of the sixth series, "Tornado-ECR" (reconnaissance version) aircraft, guided missile frigates of the "Bremen" type, "Roland-2" and "Patriot" anti-aircraft missile systems, "Milan" and "Hot" anti-tank missile systems, the "Mars" multiple rocket launcher, and command and communications systems.

The program for the modernization of armored equipment (the "Leopard-1" tanks and "Marder" infantry fighting vehicle) and submarines of Project 206 is continuing.

Table 3. Distribution of the Expenditures of the FRG Defense Ministry for Procurements of Weapons and Military Equipment (billions of DM)

Type of Weapon and Military Equipment	Fiscal Years		Percent Change Compared With 1987
	1987	1988	
Aircraft	3.0	2.5	-16.7
Armored equipment	1.1	1.4	27.3
Ammunition	2.4	2.4	0.0
Naval equipment	1.0	1.2	20.0
Artillery and machinegun armament	1.2	1.3	8.3
Motor transport equipment	0.9	0.8	-11.1
Other	2.4	2.1	-12.5
Total	12.0	11.7	-2.5

Expenditures for scientific research and experimental design work will remain at about the same level. Of the DM2.8 billion allocated for these purposes, 350 million are designated for the development of the tactical fighter of the 1990's, 178 million for the improvement of the "Tornado" aircraft, and 130 million for the establishment and testing of troop command and control systems. About 31 percent of all the expenditures for scientific research and experimental design work are going for research in the area of advanced technologies (847 million compared with 835 million in 1987). At the present time, the most attention is concentrated on the development of projects for weapons and military equipment that will become operational in the 1990's: the PAH-2 anti-tank helicopter, a 120-mm self-propelled anti-tank gun, the submarine of Project 211, the guided

missile frigate of Project 124, missiles of the "air-to-ground" and "air-to-air" classes, an antitank guided missile of the third generation, and others.

It is planned to allocate DM2.2 billion to military construction in 1988 (2.3 billion in 1987). Of this sum, about 30 percent (655 million) goes for the execution of the program for the development of the NATO infrastructure in the years 1985-1990: the construction of airfields, defensive works, depots, information centers, and pipe systems. The share of the FRG in the financing of this NATO program is 27 percent. The remaining funds will be utilized to improve the national infrastructure (construction of barracks, training areas, airfields, supply bases, etc.).

Under the agreement between the FRG and the United States signed on 15 April 1982, they are continuing to finance the program to support the American armed forces stationed in the territory of West Germany. It is planned to allocate DM186 million to this in the current year (177 million in 1987), of which 52 percent is designated for military procurements, 27 percent for measures in the area of the infrastructure, and the remaining funds will go for support of personnel participating in the execution of this program and for logistic and technical support.

In recent years, in connection with the unfavorable demographic situation in the country, the Ministry of Defense has been paying close attention to the problem of the personnel strength level of the Bundeswehr. For this purpose, funds have been allocated in 1988 for the support of a larger number of cadre and contract military personnel as well as T/O positions for particular categories of officer personnel and civilian employees of the Bundeswehr.

Thus, the military and political leadership of the FRG has taken the course of raising the efficiency of utilization of the funds allocated for military purposes while maintaining their high level for the purpose of increasing the fighting strength of its armed forces primarily through the provision of an outstripping increase in expenditures for development and procurement of the latest systems of armament and military equipment.

In November 1987, the National Assembly of FRANCE approved a budget bill of the Ministry of Defense for the 1988 fiscal year (coincides with the calendar year) in the amount of Fr174.3 billion² (\$28.9 billion), which is 3 percent above the level of the previous year. The budget will increase by 0.6 percent in constant prices. The share of military expenditures in the country's gross domestic product will be 3.9 percent and 16.1 of the state budget.

Current expenditures linked with the support of military and civilian personnel, combat training, and the logistic and technical support of troops (Fr83.4 billion) remained practically unchanged in comparison with 1987 (increase of 0.05 percent). On the other hand, expenditures for the technical equipment of the armed forces (90.9 billion) increased by 5.9 percent.

The budget of the French Ministry of Defense again confirmed the striving of the government to develop national nuclear forces, with the help of which, as former Minister of Defense A. Giraud declared, the country can compensate for the supposed "imbalance of conventional arms in Europe." Fr30.5 billion have been allocated to these purposes, which exceeds the level of the previous year by 9.9 percent (the increase will be 7.3 percent in constant prices). It is planned to allocate Fr23.6 billion of the total sum to the development of strategic nuclear forces and 6.9 billion to the development of operational and tactical nuclear forces. These funds will permit the development of the new submarine-launched ballistic missile M5 (with nine warheads) for the SSBN of the new generation now under construction (it is planned to be commissioned in 1994) and the land-based mobile strategic missile S4 weighing 9 tons and having a range capability of 3,500 km. In the current year, it is planned to deliver to the forces 16 and to procure 8 "Mirage-2000N" fighter bombers armed with ASMP guided missiles of the class "air-to-ground" with a nuclear warhead and to reequip the "Super Etandard" to carry these missiles. They will continue to develop the operational-tactical missile "Gades" intended to replace the "Pluton" missiles at the tactical level (in 1992, according to plans).

The development of other major projects is linked with the modernization of conventional arms. Among the most important of them are: the construction of the head nuclear aircraft carrier "Charles de Gaulle" in the series, the continuation of the development and testing of the new tank "Leclerc", the tactical fighter for the air and naval forces based on the experimental aircraft "Rafal," and the French-West German combat helicopter in the PAH/CATH program. They will complete the work to develop the helicopter lateral surveillance radar ORCHIDEE (Observatoire Radar Coherent Helicoptere d'Investigation des Elements Ennemis).

For the first time, the 1988 budget includes a special subhead for the financing of space programs. It is planned to spend Fr1.4 billion for these purposes. Under the 5-year program for the equipment of the armed forces, expenditures for space programs will increase by a factor of six from 1987 to 1991. The funds will go mainly for the development of communications and observation satellites.

The distribution of the Defense Ministry budget according to service branches is presented in Table 4.

Table 4. Distribution of the French Defense Ministry Budget by Service Branch (in billions of francs)

Classes of Expenditures	Fiscal Years		Increase Compared With 1987, Percent
	1987	1988	
Ground forces	45.1	45.5	0.9
Air forces	35.7	35.9	0.6
Naval forces	31.8	33.3	4.7
Gendarmerie	15.0	15.4	2.7
Other organizations and facilities*	41.6	44.2	6.2
Total	169.2	174.3	3.0

*Funds shown in this class are not distributed in the service branches.

In the current year, the following types of weapons will be ordered (numbers going to the forces in parentheses) to equip the ground forces: 75 (75) main battle tanks AMX-30B2, 61 (18) 155-mm artillery gun, 6 (0) MLRS multiple rocket launcher, 25 (28) infantry fighting vehicles, 443 (265) armored personnel carriers, and 15 (15) "Gazelle" helicopters gunships.

Table 5. Distribution of the Italian Defense Ministry Budget by Specific Designation (in billions of lira)

Classes of Expenditures	Fiscal Years		Percent Increase in Comparison With 1987
	1987	1988	
Support and training of military personnel	3,992	4,421	10.7
Support and training of civilian employees	1,139	1,195	4.9
Operation, maintenance and repair of military equipment	1,518	1,624	7.0
Transport equipment, petroleum oils and lubricants	726	893	23.0
Engineering and construction work	867	887	2.3
Technical equipment of armed forces	4,998	5,381	7.7
Carbineer troops	3,081	3,523	14.3
Other expenditures	3,008	3,076	2.3
Total	19,329	21,000	8.6

The technical equipment of the armed forces (5.381 trillion lira or 25.6 percent) is the largest subhead in the budget of the Ministry of Defense. It includes expenditures for the procurement of weapons and military equipment, scientific research and experimental design work, and the development of the infrastructure in the interests of the armed forces (with the exception of carbineer troops).

In the current year, 1.692 trillion lira will be spent on the arming and equipping of the ground forces. It is proposed that the largest part of these funds go for the

The following will be procured for the air forces (going to the forces): 27 (17) "Mirage-2000DA" fighters, 6 (9) "Ecurei" helicopters, 0 (24) "Epsilon" training aircraft, 6 (1) C-130 "Hercules" military transport aircraft, 150 (195) guided missiles of the "air-to-air" class, 180 (69) antiaircraft missiles, and 143 (210) aircraft bombs.

This year the country's naval forces will receive: the head guided missile destroyer "Cassar," the fourth nuclear-powered submarine of the "Rubis" type, and three minehunters of the "Eridan" type. They will finance orders for the construction of one guided missile destroyer, two minesweeping ships, and six "Atlantique-2" base patrol aircraft.

In evaluating the overall budget of the French Ministry of Defense for 1988, foreign specialists note the tendency toward the accelerated increase in expenditures for the technical equipment of the armed forces. It reflects the striving of the country's military and political leadership to increase the fighting strength of the armed forces in the framework of the policy of deterrence.

The budget bill for the Ministry of Defense of ITALY for fiscal year 1988 (coincides with calendar year 1988) is for the amount of 21 trillion lira (\$16.2 billion), which exceeds the level of the previous year by 8.6 percent (Table 5). The relative share of appropriations to the Ministry of Defense in the 1988 state budget is 4.6 percent.

acquisition and modernization of the means of antitank billion lira for the A.129 "Mangusta" helicopter gunships, 106 billion lira for the "Milan" antitank missile system and 14 billion for the "Tow" antitank missile system) and antiaircraft defense (106.2 billion lira for the "Skyguard-Aspide" and 61 billion lira for the "Improved Hawk" antiaircraft missile systems, a total of 80.5 billion lira for the "Stinger" and "Mistral" portable antiaircraft missile systems, and 101 billion lira for the "Madis" self-propelled antiaircraft mount.

Of the 1.828 trillion lira allocated this year for the equipment of the air forces, it is intended to use most of

it for the procurement of the tactical fighters AMX (517 billion lira) and "Tornado" (460 billion), the "Spada" antiaircraft missile system armed with "Aspide" surface-to-air missiles (200 billion), and aircraft detection radar (55 billion).

The cost of carrying out the programs to reequip the naval forces (under the 1988 Defense Ministry budget) will be 1.232 trillion lira. It is planned to use these funds to continue the construction of two guided missile destroyers of the "Animoso" type (257 billion lira), minehunters of the "Lerice" type (57.7 billion), and helicopter-assault ships-docks of the "San Giorgio" type (5.6 billion). In addition, they are financing the construction of a series of corvettes (small antisubmarine ships) of the "Minerva" type and submarines of the "Sauro" type as well as the completion of the light aircraft carrier "Giuseppe Garibaldi."

The funds for the technical equipment of the carbineer troops (75 billion lira), allocated in a separate subhead of the Defense Ministry budget, are being spent primarily for the procurement of small arms, light helicopters, wheeled armored vehicles, and motor transport equipment.

To reduce Italy's lag behind the leading European NATO countries in the area of military technology, the country's ruling circles are forcing an increase in the scope of the financing of research and developments in the interests of the Ministry of Defense. In 1988, the Defense Ministry is receiving 875 billion lira to carry out military research and experimental design work. This is 77.8 percent more than in the previous year. Of these funds, 329.3 billion lira are designated for the financing of scientific research and experimental design work in the interests of the ground forces, 207 billion for the air forces, and 242.2 billion for the naval forces. The closest attention is being paid to the implementation of the programs for financing the development of the tactical fighter AMX (together with Brazil), the antisubmarine helicopter EH-101 (with Great Britain) and the "Katrin" automated communications system for the army corps.

The cost of the program for military construction in the current year will reach 1.466 trillion lira, of which expenditures for the building of facilities in the infrastructure will be 579 billion (under the subhead "Technical Equipment of the Armed Forces") and 887 billion for their repair and reconstruction (under the subhead "Engineering Construction Work"). In 1988, in carrying out its alliance obligations in NATO, the Italian Ministry of Defense intends to increase the amount of funding for the development of the bloc infrastructure to 178 billion lira (compared with 84 billion in 1987).

Thanks to the peaceful initiatives of the Soviet Union, the process of improving the international situation and reducing nuclear missile potentials has begun. A Soviet-American agreement on the elimination of medium and shorter-range missiles has been signed and ratified. At

the same time, the indicated data on the size and structure of the military expenditures of the key NATO countries are graphic evidence of the continuing increase in the combat power of their armed forces for the purpose of further strengthening the bloc and achieving military superiority over the USSR and its allies in the Warsaw Pact.

Footnotes

1. So-called general military expenditures under NATO criteria.
2. Without taking into account expenditures for the pensions of former servicemen (Fr38.5 billion) and funds allocated for military purposes through other ministries.

COPYRIGHT: "Zarubezhnoye voyennoye obozreniye", 1988.

Views on Civil Defense in the United States

18010239m Moscow ZARUBEZHNOYE

VOYENNOYE OBOZRENIYE in Russian No 9, Sep 88
(signed to press 7 Sep 88) pp 70-74

[Article by I. Mysyuk: "Views on Civil Defense in the United States"]

[Text] U.S. policy in the area of civil defense in the 1980's was influenced by the intense conflict of opinions on a large range of problems, beginning with the question of the advisability of the existence of the civil defense system itself and extending to the specific directions of its development. The different points of view presented in the foreign press are of interest in explaining the existing approach to the establishment of a civil defense system.

The contradicting views on the role of civil defense and the prospects for its development are dictated, in the opinion of specialists in this area, by the different assessment of such important aspects as the probability of the outbreak of nuclear war, the means by which it could be unleashed and waged, the possibilities of civil defense to reduce the damage and eliminate the consequences of a nuclear strike, the influence of civil defense on the strategic balance of forces and disarmament processes, and the like.

Probability of the outbreak of a nuclear war. As a result of the recognition of the impossibility of achieving victory in a nuclear war and the catastrophic nature of its consequences, according to some American experts and public figures, the probability of the outbreak of a conflict of this kind is so small and the possibilities of defending the population and the economy against contemporary weapons are so doubtful that the establishment of a civil defense system is becoming irrational.

In the opinion of J. Green, former deputy director of the civil readiness directorate of the Department of Defense and specialist in the area of research on the effectiveness of civil defense, no one can give a definite answer to the question of whether the probability of the outbreak of a nuclear war is high enough to warrant measures to protect against its consequences. He, just as the current administration of the Federal Emergency Management Agency (FEMA), believes that it would be more nearly correct to speak not of the probability but of the possibility of its outbreak, which continues to exist even in the event of the signing of an agreement with the USSR on the elimination of strategic nuclear weapons.

"Although a nuclear war is considered highly improbable, it is still not impossible. The government cannot allow itself the luxury of ignoring the question of civil defense," states the FEMA report. According to FEMA and Defense Department experts, the presumed consequences of a nuclear war and the imperfection of civil defense plans do not free the country's military and political leadership from the necessity of resolving the problem of vulnerability and from the responsibility for providing for the protection and survival of the country's civilian sector. Especially since in the event of an acute aggravation of the international situation part of the population will be spontaneously evacuated in any case.

The understanding of this circumstance and the striving to maintain control of the internal political situation under emergency circumstances in wartime and peacetime (under the conditions of natural disasters and major industrial accidents and catastrophes) make it necessary to work out plans for the evacuation of the population and other civil defense measures. But the \$130-150 million annually appropriated by Congress from the federal budget and approximately the same sum from state funding are not enough to resolve this task adequately on the scale of the entire country.

In this connection, less attention has been paid in recent years to preparing the evacuation of the population. The main efforts are being aimed at the protection and guarantee of the stable functioning of the authorities, key departments and FEMA. The country's military and political leadership views the increase in administrative efficiency as the optimum direction in the improvement of civil defense and the entire system for preparing the civilian sector for war in general.

To a considerable degree, the contradictions in the assessments of the advisability of civil defense have to do with different views on the means of unleashing, the nature and scope of nuclear war. At the same time, the following aspects are considered important: will it begin under the conditions of complete surprise or after a period of aggravation of the international situation (crisis); will the nuclear strikes be aimed at cities or will

the adversary restrict himself to military facilities; will the nuclear war be limited in nature or will it escalate into a general war; how long will the nuclear phase of the conflict last?

In 1983, T. Herndon, chairman of the public organization "Citizens Against Nuclear War" and executive director of the American Civil Defense Association, expressed disagreement with the scenarios of nuclear war that are the basis of the FEMA plans for preparing the civilian sector for emergency conditions. In his assessment, these scenarios are too optimistic, the assumptions about the existence of a period of aggravation of the international situation preceding the delivery of nuclear strikes, about the short duration of the nuclear phase, and about the fact that nuclear power plants will not be destroyed are unrealistic and contrived, and the plans of the FEMA are not viable. This point of view is typical for representatives of those strata of the American public that are against any preparation of the country's civilian sector for nuclear war.

The adherents of the further improvement of the civil defense system believe that the sudden and mass employment of nuclear weapons against the entire complex of military and civilian installations is not very likely and that the use of nuclear weapons is possible only after a period of aggravation of the international situation or in the course of the escalation of a local armed conflict with conventional weapons into a nuclear war. They also believe that such weapons will be employed primarily against military (nuclear delivery systems, command posts for the command and control of armed forces, and the like) and military-industrial installations with the objective of depriving the adversary of the possibility of continuing the war. In the opinion of the supporters of a strong civil defense, the war can be waged so that the population will serve as a "hostage," as it were, and the possibility of annihilating that population will play the role of the main and decisive factor in "deterring" the adversary. In such a case, cities, in contrast to military and key facilities, would not be the primary targets of destruction, which somewhat facilitates the resolution of civil defense tasks. This supposition is also considered in the practical preparation of the plans for the evacuation of the American population.

The difference in the views on the most probable nature and course of the war leads to fundamental differences in assessing the possibilities of civil defense. In the unfavorable version of the development of the military and strategic situation, the possibilities of a civil defense system will not, in the opinion of American specialists, substantially influence the survival of the country. In the event of the limited use of nuclear weapons, however, civil defense can, with the existence of active components of strategic defense (antiaircraft, antisubmarine and ABM defense), protect 80-90 percent of the American population and ensure the restoration of the political, economic and military positions of the United States in an acceptable amount of time.

Those who reject the expediency of the development of civil defense present the **thesis of the impossibility of survival in a nuclear war**. It is based on the premise of the global catastrophic consequences of the large-scale use of nuclear weapons as reflected in the hypothesis of "nuclear winter," which puts in doubt the possibility of survival and the reestablishment of human civilization. At the same time, there are specialists who stress the hypothetical nature of this theory as well as the fundamental limitedness of the analysis and comprehensive evaluation of the diverse consequences of the employment of nuclear weapons. The proposition of the global catastrophic consequences of the use of nuclear weapons takes on particular meaning in combination with the asserted impossibility of limiting a nuclear war under the existing arsenals of nuclear weapons.

The hypothesis of "nuclear winter" essentially confirms the limited possibilities of the civil defense system and, at the same time, puts in doubt the reasonableness of the establishment and improvement of nuclear potentials themselves, which are the source of the threat to the people and the environment in which they live. Some authors of this hypothesis make the resolution of the problem of the expediency of civil defense a function not so much of the assessments of its possibilities under the conditions of some particular version of a nuclear conflict as of the results of negotiations on reductions of strategic nuclear arms and the prospects for the elimination of the nuclear threat on an international scale. Such a point of view is held, in particular, by C. Sagan, who does not reject as useless measures to protect the population and economy.

The military and political leadership of the United States does not view all of the arguments on the global nature of the consequences of nuclear war as a sufficiently significant reason to stop planning protective measures. Rather on the contrary, they are seen as proof of the necessity of preparing civil defense for nuclear war.

The opinion of some American specialists and politicians **on the destabilizing influence of civil defense on the strategic balance and on the international situation** is also utilized as an argument against carrying out measures to protect the population and economy of the United States and to prepare the entire civilian sector for war. In striving to calm the public and to dispel their doubts with respect to the possible consequences of the development and implementation of civil defense plans, however, some American specialists assert that this system will not have a destabilizing impact on the balance of power of the opposing sides and on the international situation. And what is more, one hears the opinion that a developed civil defense can have a positive influence on relations with the probable adversary.

On the other hand, attempts to achieve superiority over the adversary in the protection of administrative and industrial installations (with the help of the antiaircraft and civil defense systems and other means) under the

conditions of the approximate parity of the nuclear potentials of the opposing sides are viewed in a number of cases as destabilizing influences, possibly even provoking a preemptive strike (especially if the population will be protected by means of evacuation, which requires a rather long time and cannot go unnoticed by the adversary). The American press, citing high Defense Department officials, notes that the side able to carry out civil defense measures in time and thereby achieve a certain reserve of time, making it possible to threaten nuclear strikes against the adversary's population centers in subsequent stages of the conflict, may be in the most favorable position. It is thought that contemporary means of reconnaissance and command make the secret and simultaneously full activation of civil defense forces and systems with the participation of the population impracticable. Therefore, in preparing strategic nuclear forces for different versions of an armed conflict in a period when the situation is worsening, the partial activation of the civil defense system, including in particular the main administrative authorities and the communications and warning systems, more nearly meets the requirement of secrecy (especially with the background of command and staff exercises). Certainly such a version of the activation of the civil defense system (especially with ABM defense) can be and is seen by some American specialists as evidence of preparation for the surprise use of nuclear weapons and as a destabilizing factor capable of provoking the adversary into a preemptive nuclear strike.

The version of secret partial activation of civil defense more nearly corresponds to the practical actions of the FEMA, which is relying on the improvement of command and control as well as communications, warning and information systems. The administration of the FEMA views these directions as the basic condition for raising the effectiveness of the entire system for preparing the civilian sector for war.

It is precisely this circumstance that determined the support that the current U.S. administration, Defense Department and Congress have lent to the concept of "integrated emergency management" put forth back in 1983 for the establishment of a national system of authorities managing the country's civilian sector under emergency conditions (National Emergency Management System—NEMS) of the same type as the national system of operational management of the U.S. Armed Forces. This position of the FEMA with respect to the development of a unified system of management under emergency conditions most nearly corresponds to the officially recognized concept of a "limited nuclear conflict" ("controllable nuclear conflict") as well as to the basic direction of the practical measures of the U.S. military and political leadership toward the achievement of strategic superiority over the probable adversary, including through a strengthening of civil defense.

Measures being carried out in accordance with the "Star Wars" program are having a large impact on the course

of the discussion of questions relating both to the evaluation of the advisability of civil defense as well as to the choice of ways for its further development. The opinion of the inadvisability of the establishment of civil defense on account of the deployment of ABM defense is rather widespread in the United States. But the administration is taking a different position on this question. Recognizing that the comprehensive and total protection of the country's territory and population is an extraordinarily complex problem and that a civil defense system alone is incapable of reducing losses to an "acceptable" level, the military and political leadership of the United States is putting its hopes on the successful resolution of the problem of vulnerability with a balanced development of strategic offensive forces and all components of strategic defense as well as with a course of negotiations on the reduction of strategic nuclear forces favorable to the United States. With the improvement of the active components of strategic defense and depending upon the negotiations, therefore, the interest in civil defense may increase due to the fact that the effect of their joint application will be significantly greater than in the utilization of civil defense alone or active components alone.

In addition, as FEMA representatives stress, the population needs protection not only against intercontinental ballistic missiles but also against other weapons (bombs, cruise missiles, and so on). In this connection, they recommend that the policy of the United States in the area of civil defense not be made exclusively dependent upon the establishment of an ABM system and also point out the fact that civil defense measures are also essential during peacetime to protect against natural disasters, industrial accidents and catastrophies and to eliminate their consequences. In the final analysis, such a point of view has a predominant influence on the formation of policy in the civil defense area.

To a considerable extent, the discrepancy in approaches to the question of the advisability of civil defense is dictated by the difference in views on the **ways to raise the effectiveness of the military and political course of the United States**. The advisability of civil defense is often rejected by those who think it necessary to rely on offensive arms. In the past, especially at the end of the 1960's and beginning of the 1970's, the rapidly developing military technology and traditional devotion to the buildup of the nuclear arsenal continually reduced the significance of civil defense programs, the possibilities of which under the very worst versions of the military-strategic situation are rated as incomparably low relative to the capabilities of weapons. According to current views on the development of the nuclear potential, however, the offensive and defensive components of military power are no longer in opposition. To be sure, as noted by T. G. Kerr, American specialist on civil defense matters, most Americans continue to consider the development of new weapon systems to be the only way to resolve the question of the vulnerability of the territory of the United States, assuming that this will do more to

deter a "potential aggressor." The administration now in power is proceeding in this question from the necessity of the flexible combination of the offensive and defensive components of military power.

The problem of freezing nuclear arsenals also plays a significant role in the discussion of the advisability of civil defense. In the opinion of the adherents of disarmament (through a freeze of nuclear arsenals with their subsequent reduction), the optimistic illusions with respect to civil defense can lead to a weakening of the public antiwar movement and to an increased probability of the outbreak of nuclear war. Thus, the already mentioned T. Herndon accused representatives of the military and political leadership of trying to create the impression of the possibility of achieving victory in a nuclear war when there is a large-scale civil defense system. He believes that the entire campaign to discuss the prospects of its development is in itself one of the aspects of psychological warfare. On this basis, he, just as several other public figures, proposes the renunciation of the civil defense system.

In responding to the opponents of the establishment of civil defense and in substantiating its advisability, a number of American specialists are pointing out that the technology for the production of nuclear weapons is becoming more and more accessible to "Third World" countries and therefore even the complete renunciation of weapons of this kind by the USSR and United States in the distant future will not eliminate the threat of their use by some other state or terrorist group. In time, with the proliferation of nuclear weapons, this danger will increase, dictating the advisability and necessity of a civil defense system.

In criticizing the superficiality of the opinions of the supporters of the freezing of nuclear arsenals and in speaking in the press and on television on current questions in the U.S. military policy, G. Maccabi reveals the nature of the more profound and realistic, in his opinion, comprehensive approach to civil defense. He writes that the freezing of nuclear arsenals and stopping of the development and testing of new types of weapons means the retention of old systems with more powerful nuclear warheads. Their utilization in the event of war will lead to more destructive consequences for humanity than the employment of precise low-power munitions. The freezing of nuclear arsenals would put an end to this favorable—in his opinion—tendency and would increase the danger and probability of the irreversible ecological consequences of nuclear war. He therefore proposes excluding cities from the list of targets (achieving this on the part of the probable adversary as well), continuing the modernization of armed forces in the direction of the improvement of precise weapon systems (nuclear and conventional), negotiating with the USSR on the reduction of strategic nuclear arms, developing and deploying active components of strategic defense, and carrying out measures to improve civil defense.

It is precisely this line that the military and political leadership of the United States is actually following.

The thesis of the impossibility of rebuilding the country's economy after a nuclear war, of the extreme complexity and insolubility of the problems of providing the population with food and medical supplies under emergency conditions, and of the inevitable destabilization of the internal political situation under such circumstances, which is fraught with serious social disorders and a change of political authority, is also frequently presented as an argument against the advisability of civil defense.

In one of the studies by the System Planning Corporation dedicated to the assessment of the effectiveness of various versions of the programs for the development of civil defense, it is pointed out that with the activation of civil defense in the event of war, "too many people survive" in the United States, whereas the protection of production capacities is practically impossible. This results in a disproportion between the size of the country's surviving population and the capabilities of the economy to provide that population with food products, essential items, work, etc. This will lead to social disorder and a slowing of the recovery. In addition, representatives of a number of states and local authorities believe that under emergency conditions the administrative agencies and FEMA are incapable of maintaining social stability and control of the internal political situation, especially when evacuation is carried out.

The monography of the American scientist A. Katz, "Life After Nuclear War," examines the different consequences of an armed conflict with the use of nuclear weapons and the problems in restoring state control and the socioeconomic and political structures of the nation. It is thereby stressed that the mass unorganized evacuation (according to estimates by American specialists, the number of evacuated people will be approximately 30 to 50 million) will lead to a cessation of production, chaos in the economy and finances, and to a sharp aggravation of social and racial conflicts threatening the political order, that is, to the breakdown of the existing social and economic system even without nuclear war. At the same time, the author of the book writes that it is possible to inflict unacceptable economic and political damage¹ to the United States through the use of even a relatively small number (400-500) of precise nuclear weapons against the enterprises of key economic sectors. A. Katz stresses that whereas under specific conditions the problem of protecting the population and state authorities can be resolved through evacuation and sheltering in protective structures, it is practically impossible to protect fixed and very vulnerable facilities through civil defense forces. The construction of underground enterprises is possible in by no means all industrial sectors and the dismantling and sheltering of production equipment, raw materials and semifinished products require considerable time and expenditures. The standard time

periods for the emergency shutdown of enterprises cannot always be observed. At the same time, the breakdown of technology will mean the partial or complete loss of production capacities, even if no nuclear strikes are inflicted against enterprises. In addition, the carrying out of work to shelter some of the equipment and semifinished products can lead to the cessation of production at a time when it is necessary to shift to a different products list and to increase output in accordance with wartime needs.

At the beginning of the 1980's, considering it necessary to protect industrial facilities, the U.S. administration insisted on having the 7-year program for the improvement of civil defense include large-scale measures for the planning and construction of protective structures for the workers of key economic sectors and the carrying out of research work in these areas (which would increase the cost of the realization of this program from \$4.2 billion to about \$10 billion). But Congress did not approve this proposal and at the present time there are no appropriations for this work either in the federal budget or in the FEMA budget. The FEMA is striving to compensate for the lack of funds by improving the system for the management of activities in all directions of the preparation of the civilian sector for war and through the flexible planning of the distribution and redistribution (under emergency conditions) of production capacities, raw materials and semifinished products.

Officially, nevertheless, the divergent views on the advisability of civil defense prevalent in the American press and the different approaches to the resolution of specific questions do not release the civil defense authorities and the entire system for preparing the civilian sector for war from the responsibility to protect the population, economic facilities and administrative-political authorities of the state structure. The necessity of a comprehensive resolution of these problems is viewed in the United States as an important military, political and socioeconomic problem. The realization of the probable consequences of a nuclear war, however catastrophic they may seem, does not, in the opinion of the American leadership, remove from the agenda the question of the necessity of formulating emergency plans in the area of civil defense. Since the beginning of the 1980's, civil defense has been prepared in accordance with the requirements of the concept of "limited nuclear war." To a considerable extent, the prospects for its development are determined by the struggle of different points of view and in any case depend directly upon the views on the start, nature, scope and outcome of nuclear war. They are linked with attempts to achieve strategic military superiority over the USSR not only through the improvement of the nuclear potential but also through the accelerated development of strategic defensive forces. Great importance is thereby given to the achievement of advantageous results for the United States in the course of negotiations on the reduction of strategic offensive arms.

Overall the military and political leadership of the United States is striving to maintain the civil defense

system at the level of the current demands of the concept of "limited nuclear war," paying particular attention to its more flexible utilization in times when the situation is strained and in the course of possible military actions.

Footnotes

1. Unacceptable damage in the United States is said to be that damage in which the level of destruction of the population, economy and agencies of the administrative-political structure of the state put in doubt the possibility of its survival and restoration as a political and socioeconomic community after an exchange of nuclear strikes. The capability of inflicting unacceptable damage to the probable adversary under any conditions of the situation is considered to be one of the basic factors in the military and political course of the United States.

COPYRIGHT: "Zarubezhnoye voyennoye obozreniye", 1988.

New English Aircraft

18010239n Moscow ZARUBEZHNOYE VOYENNOYE OBOZRENIYE in Russian No 9, Sep 88 (signed to press 7 Sep 88) pp 76-77

[Article by Col I. Karenin: "New English Aircraft"]

[Text] During the last 2 years, the English firm British Aerospace has been researching the possibility of building an SABA (Small Agile Battlefield Aircraft) intended primarily to combat strike helicopters and also to provide direct air support for the ground forces. Judging by the reports of the foreign press, particular attention in designing the aircraft will be given to the fulfillment of the basic requirement—sufficient maneuverability for air combat at low altitude with targets having high

performance characteristics. In particular, the new aircraft must be able to turn 180 degrees within 5 seconds in the operating mode (speed equal to Mach 0.4) and have a minimum turning radius equal to 150 meters. In addition, it must have the capability of making short takeoffs and landings (about 300 meters) from dirt airstrips, carry adequately powerful armament, and have a maximum endurance of 4 hours and a speed of 740 km/hour with a full bomb load.

The firm's specialists examined aircraft projects of several structural designs and after studying them they selected the single-seat aircraft of the "duck" design with a fan-driven propeller engine having two thrusting fan-driven propellers turning in opposite directions (see diagram). It is planned to build the air frame with extensive use of composite materials and also to provide armor for the cockpit. The aircraft's basic theoretical specifications (its company designation is P.12331) are as follows: maximum takeoff weight over 5,000 kg, empty weight 3,500 kg, weight of combat payload 1,800 kg, length 9.5 meters, wingspan 10.97 meters, wing surface area 20.39 square meters, engine thrust 4,500 horsepower.

The aircraft armament will include a fixed 25-mm gun (150 rounds of ammunition) and 6 guided missiles of the "air-to-air" class (AIM-9L "Sidewinder" or the advanced AIM-132) with a short range of fire or 4 "Maverick" guided missiles of the "air-to-ground" class and 2 guided missiles of the "air-to-air" class or "Hellfire" antitank guided missiles and 2 guided missiles of the "air-to-air" class. It is planned to suspend armament on six underwing hardpoints and, as a rule, a pod with electronic warfare equipment under the fuselage. In addition, they are studying the question of equipping the aircraft with a revolvable turret mount with hypersonic

Projections of the English "Sabo" Aircraft

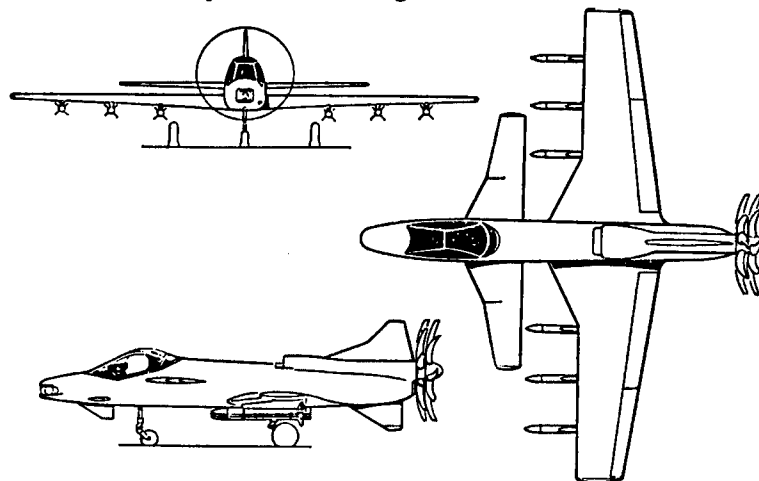

antitank missiles. The weapon control system will include an infrared forward-observation station and a laser rangefinder-target designator.

The firm is planning (in the event that it receives the necessary appropriations) to build a demonstration model of the SABA by the beginning of the 1990's, which will be usable in flight tests to evaluate the overall project in proposed design decisions.

COPYRIGHT: "Zarubezhnoye voyennoye obozreniye", 1988.

Articles Not Translated from ZARUBEZHNOYE VOYENNOYE OBOZRENIYE No 9, September 1988

18010358v Moscow ZARUBEZHNOYE VOYENNOYE OBOZRENIYE in Russian No 9, Sep 1988 (signed to press 7 Sep 88).

[Text] Commander, U.S. Army Europe (V. Filippov) .p 30

Special U.S. Air Force Training Squadron (V. Kirsanov)pp 31-35

U.S. Air Force Helicopter and Airplane Insignia (Yu. Petrov)pp 40-44

Population of the Member Countries of the Council of Cooperation of the Persian Gulf Arab Statesp 74

Information, Events, Facts: English Rapid Deployment Force Exercise (S. Anzherskiy); New Missions for the Alpha Jet (L. Monin); Accommodations for Anti-ship Missile in Iran (A. Guryanov); New Assignments (Unattributed);pp 75-78

Foreign Military Chronicle (Unattributed) pp 79-80

Color Inserts: South African 155-mm Self-propelled Howitzer, G-6; F-5E "Tiger-2" Fighter from the Aggressor Squadron; Australian Air Force Tactical Fighter F-111C; Japanese 55- and 127-mm NAR [Air-launched Anti-ship Missile]; Japanese Anti-submarine Torpedo With Active Acoustic Guidance Type 73 (G-9 or -9B); (Unattributed);Between pp 48-49.

COPYRIGHT: "Zarubezhnoye voyennoye obozreniye", 1988.

Publication Data

18010238p Moscow ZARUBEZHNOYE VOYENNOYE OBOZRENIYE in Russian No 9, Sept 88 (signed to press 7 Sept 88)

[Text] English title: FOREIGN MILITARY REVIEW

Russian title: ZARUBEZHNOYE VOYENNOYE OBOZRENIYE

Editor: V. I. Kozhemyakin

Publishing house: Izdatelstvo "Krasnaya zvezda"

Place of publication: Moscow

Date of publication: September 1988

Signed to press: 7 September 88

COPYRIGHT: "Zarubezhnoye voyennoye obozreniye", 1988