

NAVAL POSTGRADUATE SCHOOL

Monterey, California



19980421 113

DTIC QUALITY INSPECTED 3

THESIS

**CURRENT AND FUTURE EFFORTS TO VARY THE
LEVEL OF DETAIL FOR THE COMMON
OPERATIONAL PICTURE**

by

Richard S. Hager

December 1997

Thesis Co-Advisors:

Gary R. Porter
William G. Kemple

Approved for public release; distribution is unlimited.

REPORT DOCUMENTATION PAGE

Form Approved OMB No. 0704-0188

Public reporting burden for this collection of information is estimated to average 1 hour per response, including the time for reviewing instruction, searching existing data sources, gathering and maintaining the data needed, and completing and reviewing the collection of information. Send comments regarding this burden estimate or any other aspect of this collection of information, including suggestions for reducing this burden, to Washington Headquarters Services, Directorate for Information Operations and Reports, 1215 Jefferson Davis Highway, Suite 1204, Arlington, VA 22202-4302, and to the Office of Management and Budget, Paperwork Reduction Project (0704-0188) Washington DC 20503.

1. AGENCY USE ONLY (<i>Leave blank</i>)		2. REPORT DATE December 1997		3. REPORT TYPE AND DATES COVERED Master's Thesis	
4. TITLE AND SUBTITLE TITLE OF THESIS: CURRENT AND FUTURE EFFORTS TO VARY THE LEVEL OF DETAIL FOR THE COMMON OPERATIONAL PICTURE				5. FUNDING NUMBERS	
7. PERFORMING ORGANIZATION NAME(S) AND ADDRESS(ES) Naval Postgraduate School Monterey CA 93943-5000				8. PERFORMING ORGANIZATION REPORT NUMBER	
9. SPONSORING/MONITORING AGENCY NAME(S) AND ADDRESS(ES)				10. SPONSORING/MONITORING AGENCY REPORT NUMBER	
11. SUPPLEMENTARY NOTES The views expressed in this thesis are those of the author and do not reflect the official policy or position of the Department of Defense or the U.S. Government.					
12a. DISTRIBUTION/AVAILABILITY STATEMENT Approved for public release; distribution is unlimited.				12b. DISTRIBUTION CODE	
13. ABSTRACT (<i>maximum 200 words</i>) The Joint Staff developed the C4I for the Warrior Concept in 1992 which stated that the warrior needs a fused, real-time, true representation of the battlespace. To help accomplish this vision, the Global Command and Control System was created. It provides the Common Operational Picture described above, but only down to the level of the Unified Commander. This thesis is a comprehensive report that gives a complete review of the current situational awareness systems available to the commander in addition to current and future efforts to bring a common operational picture to all levels of command. These thesis is designed to give situational awareness to all levels of command. The detailed discussions in the thesis of these systems will help students and researchers in the Joint C4I curriculum at the Naval Postgraduate School develop a better understanding of the difficulties in getting a true common operational picture to all services at all levels.					
14. SUBJECT TERMS Global Command and Control System, Common Operational Picture, Situational Awareness, C4I, Command and Control, Battlespace Management,				15. NUMBER OF PAGES 98	
				16. PRICE CODE	
17. SECURITY CLASSIFICATION OF REPORT Unclassified	18. SECURITY CLASSIFICATION OF THIS PAGE Unclassified	19. SECURITY CLASSIFICATION OF ABSTRACT Unclassified	20. LIMITATION OF ABSTRACT UL		

NSN 7540-01-280-5500

Standard Form 298 (Rev. 2-89)
Prescribed by ANSI Std. Z39-18 298-102

Approved for public release; distribution is unlimited.

**CURRENT AND FUTURE EFFORTS TO VARY THE LEVEL OF DETAIL
FOR THE COMMON OPERATIONAL PICTURE**

Richard S. Hager
Lieutenant, United States Navy
B.S., United States Naval Academy, 1990

Submitted in partial fulfillment
of the requirements for the degree of

MASTER OF SCIENCE IN SYSTEMS TECHNOLOGY

from the

**NAVAL POSTGRADUATE SCHOOL
December 1997**

Author:



Richard S. Hager

Approved by:



Gary R. Porter, Co-Thesis Advisor

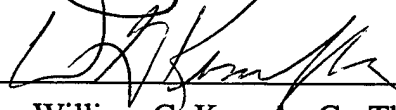

William G. Kemple, Co-Thesis Advisor



Dan Boger, Chairman
C4I Academic Group

ABSTRACT

The Joint Staff developed the C4I for the Warrior Concept in 1992 which stated that the warrior needs a fused, real-time, true representation of the battlespace. To help accomplish this vision, the Global Command and Control System was created. It provides the Common Operational Picture described above, but only down to the Unified Commander.

This thesis is a comprehensive report that gives a complete review of the current situational awareness systems available to the commander in addition to current and future efforts to bring a common operational picture to all levels of command. These systems are designed to give situational awareness to all levels of command. The detailed discussions in the thesis of these systems will help students and researchers in the Joint C4I curriculum at the Naval Postgraduate School develop a better understanding of the difficulties in getting a true common operational picture to all services at all levels.

TABLE OF CONTENTS

I	INTRODUCTION.....	1
A.	BACKGROUND.....	1
B.	PURPOSE	4
C.	THE NEED FOR A COMMON OPERATIONAL PICTURE.....	5
D.	THESIS ORGANIZAITON.....	6
II	CURRENT SITUATIONAL AWARENESS SYSTEMS AVAILABLE TO THE COMMANDER	9
A.	AIR FORCE	9
1.	Contingency Theater Automated Planning System.....	9
2.	Joint Force Air Component Command Situational Awareness System	11
B.	ARMY	11
1.	Automated Digital Data System.....	12
2.	Army Tactical Command and Control System.....	12
3.	All Source Analysis System.....	13
4.	Forward Area Air Defense Command, Control and Intelligence..	15
5.	Maneuver Control System.....	16
6.	Standard Theater Army Command and Control System.....	17
C.	JOINT.....	18
1.	Joint Tactical Information Distribution System	18
D.	NAVY AND MARINE CORPS	19
1.	Joint Maritime Command Information System.....	19
2.	Navy Tactical Data System	20
III	THE GLOBAL COMMAND AND CONTROL SYSTEM.....	21
A.	C4I FOR THE WARRIOR.....	21
B.	MIDTERM FIX.....	23
C.	DEFENSE INFORMATION INFRASTRUCTURE	25
D.	COMMON OPERATING ENVIRONMENT.....	26
E.	COMMON OPERATIONAL PICTURE.....	28
F.	LEVEL OF DETAIL.....	29
1.	Army and Marine Corps.....	31
2.	Air Force.....	31
3.	Navy	32
G.	REPORTING PROCEDURES.....	32
1.	Air Component	33
2.	Ground Component	33
3.	Naval Component.....	34
4.	Joint Special Operation Task Forces Commander	34
5.	Special Interest Forces and Tracks.....	35
H.	TRACK REPORTING.....	35
1.	Enhanced Position Location Reporting System	35

2.	Officer in Tactical Command Information Exchange System	36
3.	Situational Awareness Beacon with Reply.....	37
4.	Tactical Digital Information Links.....	37
5.	Tactical Information Broadcast System	38
6.	Tactical Related Applications	39
7.	TRI-Service Tactical Communications System	39
I.	TRACK FUSION.....	39
1.	Joint Force Commander	41
2.	Air Component Commander	41
3.	Ground Component Commander	41
4.	Maritime Component Commander.....	42
IV	CURRENT EFFORTS	43
A.	AIR FORCE	43
B.	ARMY	44
1.	Army Global Command and Control System	45
2.	Force XXI Battle Command, Brigade and Below.....	46
C.	MARINE CORPS.....	50
1.	Marine Air Ground Task Force C4I.....	50
2.	Tactical Combat Operations System	51
D.	NAVY	52
1.	Force Threat Evaluation and Weapons Assignment	52
V	FUTURE EFFORTS	55
A.	AIR FORCE	55
1.	New World Vistas Global Awareness Virtual Testbed.....	55
B.	ARMY	56
1.	Army Battlefield Command System.....	56
C.	DEFENSE ADVANCE RESEARCH PROJECT AGENCY (DARPA) ..	61
1.	Battlefield Awareness and Data Dissemination	62
D.	JOINT.....	64
1.	Advanced Battlespace Information System.....	65
E.	MARINE CORPS.....	68
1.	Command and Control Personal Computer	68
F.	NAVY	69
VI	CONCLUSIONS AND RECOMMENDATIONS.....	71
A.	CONCLUSION	71
B.	RECOMMENDATIONS.....	72
	LIST OF REFERENCES	75
	INITIAL DISTRIBUTION LIST.....	79

LIST OF ABBREVIATIONS AND ACRONYMS

ABCS	Army Battle Command System
ABIS	Advanced Battlespace Information System
ACC	Air Component Commander
ACE	Analysis and Control Element
ACTD	Advanced Concept Technology Demonstration
AD	Air Defense
ADDS	Automated Digital Data System
AGDB	Army Global Data Base
AGCCS	Army Global Command and Control System
AOR	Area of Responsibility
ARG	Amphibious Readiness Group
ASAS	All Source Analysis System
ATCCS	Army Tactical Command and Control System
ATO	Air Tasking Order
AWACS	Airborne Warning and Control System
AWIS	Army Worldwide Military Command and Control Information System
B2C2	Battalion and Below Command and Control System
BADD	Battlefield Awareness and Data Dissemination
BFA	Battlefield Functional Area
BFACS	Battlefield Functional Area Control System
BOS	Battlefield Operating System
BUU	Basic Unit User
C2	Command and Control
C2PC	Command and Control Personal Computer
C2V	Command and Control Vehicle
C3DDS	Command, Control, Communications, Decision, Display System
C4I	Command, Control, Communication, Computers, and Intelligence
C4IFTW	Command, Control, Communication, Computers, and Intelligence for the Warrior
CIC	Combat Information Center
CINC	Commander in Chief
CIS	Combat Intelligence System
CGS	Common Ground Station
CJCS	Chairman, Joint Chief of Staff
CJTF	Commander Joint Task Force
COE	Common Operating Environment

COC	Combat Operations Center
COP	Common Operational Picture
COTS	Commercial-off-the-shelf
CPU	Central Processing Unit
CSSOC	Combat Service Support Operations Center
CTP	Common Tactical Picture
DARPA	Defense Advance Research Project Agency
DII	Defense Information Infrastructure
DII COE	Defense Information Infrastructure Common Operating Environment
DISA	Defense Information System Agency
DISN	Defense Information System Network
DoD	Department of Defense
EAC	Echelon Above Corps
ECB	Echelon Corps and Below
ELINT	Electronic Intelligence
EPLRS	Enhanced Position Location Reporting System
FAAD	Forward Area Air Defense
FAADC2I	Forward Area Air Defense Command, Control and Intelligence
FBCB2	Force XXI Battle Command, Brigade and Below
FDC	Fire Direction Center
FLI	Force Level Information
FOTC	Force Over-the-Horizon Track Coordinator
G2-TOC	G2 Tactical Operations Center
GA	Global Awareness
GAVTB	Global Awareness Virtual Testbed
GBS	Global Broadcast System
GCC	Ground Component Commander
GCCS	Global Command and Control System
GOTS	Government-off-the-shelf
GIB	Global Information Base
HF	High Frequency
IDS	Information Dissemination Server
IOC	Initial Operational Capabilities
JCS	Joint Chiefs of Staff
JFACC	Joint Force Air Component Command
JFC	Joint Force Commander

JIC	Joint Intelligence Center
JMCIS	Joint Maritime Command Information System
JOA	Joint Operation Area
JROC	Joint Requirement Oversight Council
JSAS	Joint Force Air Component Command Situational Awareness System
JSOTF	Joint Special Operations Task Force
JTIDS	Joint Tactical Information Distribution System
JTF	Joint Task Force
LAN	Local Area Network
MAGTF	Marine Air Ground Task Force
MCS	Maneuver Control System
MCC	Maritime Component Commander
MSE	Mobile Subscriber Equipment
NATO	North Atlantic Treaty Organization
NCA	National Command Authority
NIMA	National Imagery and Mapping Agency
NMCC	National Military Command Center
NTDS	Navy Tactical Data System
NWV GAVTB	New World Vistas Global Awareness Virtual Testbed
OCAC	Operations Control and Analysis Center
OPFOR	Opposing Force
OSD	Office of the Secretary of Defense
OTH	Over-the-Horizon
OTCIXS System	Officer in Tactical Command Information Exchange
PLI	Position Location Information
PLRS	Position Location Reporting System
RSOC	Regional Support Operations Center
RWS	Remote Workstation
SABER	Situational Awareness Beacon with Reply
SICPS	Standard Integrated Command Post System
SIGINT	Signals Intelligence
SIPRNET	Secret Internet Protocol Router Network
SOF	Special Operations Force
STACCS	Standard Theater Army Command and Control System
TACAN	Tactical Aids to Navigation

TACC	Tactical Air Command Center
TADIL	Tactical Digital Data Link Information
TCO	Tactical Combat Operations
TEWA	Threat Evaluation and Weapon Assignment
TIBS	Tactical Information Broadcast System
TOC	Tactical Operations Center
TRAP	Tactical Related Applications
TRI-TAC	Tri-Service Tactical Communications System
UAV	Unmanned Aerial Vehicle
UB	Unified Build
UHF	Ultra High Frequency
WAM	WWMCCS Automated Data Processing Modernization
WAN	Wide Area Network
WFA	Warfighters Associates
WWMCCS	World Wide Military Command and Control System

EXECUTIVE SUMMARY

Those tasked with commanding military operations have long been responsible for comprehending all facets of the battlespace, including friendly and enemy force disposition, but they have lacked the information to fully do so. With new generations of inexpensive, commercially available computer hardware and software, the Department of Defense (DoD) has undertaken an integrated Command, Control, Communication, Computers and Intelligence (C4I) concept to give the warrior complete battlespace awareness. The Joint Chiefs of Staff (JCS) published the overall joint vision, C4I for the Warrior, that describes in detail the C4I challenges for the 21st century warrior. This states

the warrior needs a fused, real-time, true representation of the battlespace - an ability to order, respond and coordinate horizontally, and vertically to the degree necessary to prosecute his mission in that battlespace. [Ref. 1]

The Global Command and Control System was developed to give the warrior the true representation of the battlespace. The Common Operational Picture provided by the Global Command and Control System is designed to give the location of all air, sea and land forces, opposing forces and environmental factors which affect the battlespace. However, it currently only provides the National Military Command Center, Unified Commander and the Commander, Joint Task Force with the common picture that they require. It provides the same picture to the service/components (major commands), but that only partially fulfills their requirements.

The Joint Staff also has examined ways to bring the common operational picture to all levels of command. Vice Admiral Cebrowski, the former Director for C4 Systems,

J6, directed a study to examine future operational C2 system capabilities and enabling technologies. This study, by J6 and the Director of Defense Research and Engineering for the Office of the Secretary of Defense (OSD), was to be a roadmap to the C2 of the future. The findings were published in the Advanced Battlespace Information System (ABIS) vision. Each service is also working to develop systems to bring the common operational picture to all levels of command, but the efforts are service unique.

The Air Force relies heavily on the Tactical Data Links for the common operational picture. Since a new Tactical Data Link has just been fielded (Joint Tactical Information Data System), they do not have any current efforts to bring the GCCS COP to lower levels of command. While there are no new systems in development, they do have several programs in the conceptual stage to bring the Tactical Data Link to lower levels to include the fighter cockpit. Also, a test bed called the New World Vistas Global Awareness Virtual Test Bed has been established that will incorporate data from all national, strategic and tactical sensors into a single data base to give the commander a complete operational picture.

Currently the Army does not have an integrated, automated, strategic to foxhole Command and Control system. Commanders and staffs generally perform their mission using a manual system, augmented by commercially available software systems. Current fielded automation and communication systems do not provide the mobility, functional flexible or interoperability required by the Army. These shortfalls hamper the ability to transport, collect, disseminate and display information vertically and horizontally. The Army Battlefield Command Systems and the Army Global Command and Control System are being developed to overcome these shortfalls.

The Army also currently lacks a fully functional integrated battle command system for the mounted/dismounted leader at the brigade level and below. At maneuver brigade and lower echelons, there is an inadequate capability to support information needs of the commanders at each level because units are void of battle command digital information devices and rely primarily on voice communications. Current communications systems also do not provide sufficient data throughput for current and emerging large capacity data terminals. This has impeded the ability to provide the commander real-time and near real-time usable information on which to base tactical decisions. The Force XXI Battle Command, Brigade and Below is being developed to bring the common operational picture to the warrior.

Since the Navy currently has a common operational picture at all levels, it is primarily taking an evolutionary approach in the development of systems. It is updating the Joint Maritime Command Information System (JMCIS) from the UNIX based system to that of a Microsoft Windows NT based system. The new JMCIS has been named JMCIS 98 as well as GCCS-M, the Global Command and Control System - Maritime. As a consequence, the primary efforts of the Navy are to upgrade JMCIS and to develop a situational awareness system for individual warfare areas (air, surface or subsurface).

The Marine Corps, along with the Army, has an overall system to give the common operational picture to lower levels of command. The Marine Air Ground Task Force C4I (MAGTF C4I) system attempts to integrating communications and tactical data systems on the modern battlefield. The purpose of MAGTF C4I is to provide Fleet Marine Force (FMF) commanders with the means to manage the complexity of the modern battlefield. The Tactical Combat Operations (TCO) System will be the focal

point of the MAGTF C4I network. It will provide the commanders, staffs and subordinates the capability to receive, fuse, display, and disseminate C2 information, for both planning and executing phases of an operation. The system will link the operations sections of all FMF units of battalion or squadron size and larger. Marine forces embarked aboard Navy ships will "plug in" to the JMCIS terminal. When ashore, the MAGTF C4I compliant system will allow interoperability with joint forces over internal and external communications.

With the decreasing defense budget, the push for the services to save money and the current focus on joint warfare, a system developed from the GCCS COP for lower levels of command would be logical. However, each service is either developing new systems or revising current systems for use at lower levels. These systems are DII COE compliant, but they are not interoperable beyond that. The services are still developing "stovepipe" systems, but they are now DII COE compliant.

The databases being used by the services at different levels of command are not centralized as they should be. Each service continues to use its own display system and manage track information in its own database. In some cases, different levels of command maintain their own database. It is not until the CINC level that the databases are combined. This combined database is not sent down to the lower levels, unless a direct communication link is established. It is however sent up to the national level.

The primary issue that must be overcome is the one of a centralized architecture for the data contained within the database of each common operational picture. In some cases, different levels of command still maintain their own distinct database as does each service and CINC. While this should continue, the data contained within each database

should be accessible from all levels of command, both horizontally and vertically. The data should be offered in a read only manner so each command's database is not corrupted. An architecture needs to be established that ensures connectivity and interoperability between vertical and horizontal commands. Until this database architecture is established and maintained, commanders will not be able to get a true COMMON Operational Picture among all services at all levels of command.

I INTRODUCTION

This thesis gives a complete review of the current situational awareness systems available to the commander in addition to current and future efforts to bring a common operational picture to all levels of command. The detailed discussions in the thesis of these systems will help students and researchers in the Joint C4I curriculum at the Naval Postgraduate School develop a better understanding of the difficulties in getting a true common operational picture to all services at all levels.

This chapter provides a background and states the purpose, intended audience and assumptions of the thesis. It also introduces the reader to the need for a joint system that shows a complete operational picture at all levels of command. Lastly, it provides an outline for the remainder of the thesis.

A. BACKGROUND

The ability to fully comprehend all facets of the battlespace, including friendly and enemy force disposition, has long been recognized as a desirable attribute of a combat command. With new generations of inexpensive, commercially available computer hardware and software, the Department of Defense (DoD) has undertaken an integrated Command, Control, Communication, Computers and Intelligence (C4I) concept to give the warrior complete battlespace awareness. The Joint Chiefs of Staff (JCS) published the overall joint vision, C4I for the Warrior, that describes in detail the C4I challenges for the 21st century warrior. This states

the warrior needs a fused, real-time, true representation of the battlespace - an ability to order, respond and coordinate horizontally, and vertically to the degree necessary to prosecute his mission in that battlespace. [Ref. 1]

Additionally, each service has promulgated a vision that provides a blueprint on how to achieve the JCS vision from their parochial perspective. The Army published the “Enterprise Strategy”, the Navy and Marine Corps “Copernicus ... Forward” and the Air Force “Horizon”. These, together with the Joint Strategy, will provide the warrior with the information needed to ensure battlespace dominance.

The U. S. Army’s “Enterprise” takes a holistic, process-oriented view of C4I systems development, weapon and weapon support through the systems life cycle:

- systems acquisition
- systems integration
- systems improvement
- systems employment
- sustainment across the tactical, sustaining base and strategic operations.

“Copernicus ... Forward,” designed by the U. S. Navy as a user-centered C4I information management architecture, provides a blueprint for capturing technological change. It answers critical Naval C4I problems and articulates the true essence of modern command and control. “Copernicus ... Forward” lays the foundation for joint and allied operations.

“Horizon” provides the warfighter with responsive, advanced C4I services. It is a charge to lead the Air Force into an era of technological innovation and to better satisfy the warrior’s requirements. “Horizon” charts the course to orient Air Force thinking toward providing warfighters with C4I support in an expeditionary environment and to seek advantages in the coming age of information warfare. [Ref. 2]

The culmination of these three service visions yields several common positive results. The most important is the requirement to have coherent, accurate, timely situational awareness as well as vertical and horizontal information integration at all command levels. This enables commanders at all levels to share common knowledge of the battlespace. However, different levels of command do not need the same level of detail. Individual commanders must determine and define which level of information is necessary for the mission at hand and allow track managers to maintain the picture at the appropriate level.

If the common operational picture is realized then in theory all information would be available to the commander, but not all information needed by any one commander and some specific information critical to each specific operation. For example, a tank commander needs little information off the global grid to complete a successful mission. However, the information that is required must be complete, accurate and timely.

The common operational picture gives commanders, staffs and their warfighters a "common picture" of the battlefield at the same time, on a terminal device at their location. The common picture may include geographical displays of unit locations, attack routes, checkpoints, and other tactical information of relevance all on one display. Updates occur at real-time or near real-time and are sent to all commanders, staffs and warfighters. The benefit is a decrease in Command and Control (C2) decision cycle time because the operational picture shows the most current information to commanders at all levels. Situational awareness is increased because every warfighter, with the common picture, has the same information regarding friendly and enemy locations.

The operational picture also refers to a predefined representation of battlefield information. When this information is appropriately tailored in content and detail, it can provide a commander the current view of the battlespace that is required. The common picture may cross horizontal, vertical and functional boundaries. It is made up of three components: 1) situation maps and overlays (the current friendly and enemy tactical situation, the projected enemy situation and enemy resources), 2) friendly battlefield resource reports and 3) intelligence products. [Ref. 3]

B. PURPOSE

The overall goal of this thesis is to have a document that gives a complete review of the current situational awareness systems available to the commander in addition to current and future efforts to bring a common operational picture to all levels of command. This is accomplished in two steps. First, the current systems available to commanders for a common operational picture are addressed. This shows the many systems available which are “stovepipe” and therefore not interoperable. Second, the current and future systems each of the services and research agencies are developing are described. These systems will bring situational awareness to lower levels of command along all the services, not just one as is today. The thesis detailed discussions of these systems will help students and researchers in the Joint C4I curriculum at the Naval Postgraduate School develop a better understanding of the difficulties in getting a true common operational picture to all services at all levels.

C. THE NEED FOR A COMMON OPERATIONAL PICTURE

Military commanders have always desired to know the location of all troops, both enemy and friendly and the details of all other forces, activities and the environment that defines their battlespace over time. Annotated charts and maps were the first operational picture. Even as recently as World War II, Korea and Vietnam, commanders used annotated charts to display the general locations of the battlefield players. While these operational pictures gave commanders basic situational awareness, the information provided was time late and inaccurate at best.

By exploiting emerging technologies that enable rapid communication using large bandwidths over vast distances along with similar technological advances in sensors, data base management, weapon development and intelligence products, commanders now have the ability to directly command dispersed forces throughout the Area of Responsibility (AOR). Because of this, commanders demand to know the exact location of all forces, both friendly and enemy, within the AOR. This complete battlefield picture enables commanders to more effectively employ their forces and dramatically reduces the chance of fratricide.

In 1993, the Joint Staff reinforced the need for situational awareness by stating that a fully developed C4I network of fused, automatically updated information must be available to the warfighter. Utilizing this network, as well as emerging technologies, the joint warfighter can use current positional information to obtain the desired operational picture on a single display. Additionally, access to a common picture that displays identified enemy and friendly units on a global-wide scale will allow dissimilar forces and platforms to collaboratively plan and execute comprehensive tactical operations. The

commanders then must use the information to make C2 decisions by evaluating the operational picture. [Ref. 1]

A common operational picture must provide the Unified Combatant Commanders (CINCs) the ability to rapidly provide military information to the National Command Authority (NCA). The same information must also be provided down to the Commander Joint Task Force (CJTF) and JTF components. Additionally, the information will be provided horizontally from the CINC to the supporting CINCs, supporting agencies, services and coalition partners. The system on which the operational picture resides must be flexible enough to allow for differences in organizational structures and situational variances caused by the operation at hand. Lastly, it must also support the different operating styles and personalities of each commander.

D. THESIS ORGANIZATION

Chapter II provides an in-depth review of the current situational awareness systems available to the commander today.

Chapter III focuses on GCCS. First background is provided, followed by discussions on midterm fixes, DII, COE, COP, level of detail, reporting procedures, track reporting and track fusion as they relate to GCCS and the warrior's COP.

Chapter IV discusses current efforts of the services to bring the COP to all levels of command.

Chapter V examines future efforts of the services as well as Defense Agencies. It also examines a Joint Staff study on future requirements for commanders to have a common operational picture.

Chapter VI presents recommendations and makes conclusions.

II CURRENT SITUATIONAL AWARENESS SYSTEMS AVAILABLE TO THE COMMANDER

The first chapter provided an introduction to the thesis. It also provided the purpose and need for the common operational picture. This chapter provides an in-depth review of the current situational awareness systems available to the commander today. There are many stovepipe COP systems in DoD that provide overlap in functionality but are not interoperable. Each service contributes to this problem. Additionally, the COPS and symbology within each system is not scaleable beyond their own parochial needs. The following pages describe these systems.

A. AIR FORCE

There are currently three primary situational awareness systems used by the Air Force. They are the Contingency Theater Automated Planning System (CTAPS), the Joint Force Air Component Commander Situational Awareness System (JSAS) and the Tactical Digital Information Link (TADILs), described in detail in Chapter III. The following is a detailed summary of CTAPS and JSAS.

1. Contingency Theater Automated Planning System

The Contingency Theater Automated Planning System is an "umbrella" program for modernizing the Air Operations Center (AOC), Air Support Operations Center (ASOC) and the Unit Level (UL) in support of air battle operations. The CTAPS program interfaces with other Air Force and other service systems, including other theater battle management core systems, the Army's Standard Theater Army Command and

Control System (STACCS) and the Navy's Joint Maritime Command Information System (JMCIS), both described in this chapter.

CTAPS has adopted a development integration methodology based on a "common core" computer system. This common core system is based on COTS, open system, standard hardware and software. By utilizing an open system, CTAPS can host a variety of mission applications tailored to specific C2 functions, including a Battlefield Situation Display (BSD). The BSD will be incorporated into future versions of CTAPS.

The BSD will provide a map-based display of the air, land and surface situation. Implicit in the concept is a "view" of the battlefield with the attributes of selectability and tailorability of the view, common identification of targets and other objects in the view and access through the view to underlying data. The CTAPS BSD project will gradually acquire, field, and support these attributes as CTAPS capability evolves and incorporates near-real time data feeds from TADIL-A, TADIL-B, TADIL-J, JMCIS (all described in Chapter III), NATO Link-1 and Link-21, and other information sources.

The current display function presents the user with a graphical representation of the air and ground battlefield situation as depicted on map, chart, and imagery products in support of intelligence planning, target support, and mission planning and execution activities. Intelligence, operations, and analytical information (both alpha-numeric and graphical), as derived from user tools available as separate functions on the system, will be created as separate, non-destructive overlays. The following are available for layered viewing: threat analysis (Individual Many-on-Many (IMOM)-type capability), enemy C4I information, mission support information, escape and evasion data, broadcast information

(tracks, sites, ellipses, threat rings, direction of movement, TIBS messages (described in Chapter III) and graphic depiction of imagery). [Ref. 4]

2. Joint Force Air Component Command Situational Awareness System

The Air Force's Joint Force Air Component Commander (JFACC) Situational Awareness System (JSAS) shows the commander the complete battlefield. It receives electronic intelligence (ELINT) data from National and airborne sources, radar data, naval force position data and ground force positional data. JSAS also correlates the above data and then displays the fused picture. It is capable of providing the commander with:

- UAV live-feed capable for real-time video
- 3D client/server capable for up-to-date imagery input
- Standard National Imagery and Mapping Agency formats for maps, imagery and terrain
- 3D sensor modeling of satellites, aircraft and ground defense systems
- Statistical graphs and tables on coverage capabilities. [Ref. 5]

B. ARMY

The Army has the widest range of systems, offering different levels of detail of a common picture. Most of these are going to be migrated into the Army Battlefield Command System (ABCS), which will be described in Chapter V.

1. Automated Digital Data System

The Automated Digital Data System (ADDS) is a collection of two automated data distribution systems that give commanders a secure means to collect, manage and disseminate near real-time locations of enemy and friendly positions and reconnaissance and sensory information, as well as targeting data. The two systems that make up the ADDS are the Joint Tactical Distribution Information System (JTIDS) and the Enhanced Position Location Reporting System (EPLRS). EPLRS and JTIDS will be described in Chapter III. ADDS is one of three systems that comprise the Communications Hub for the Army Tactical Command and Control System (ATCCS). [Ref. 6]

2. Army Tactical Command and Control System

The Army Tactical Command and Control System (ATCCS), part of the Army's Enterprise Strategy, is a hierarchy of computerized control systems operating within five Army Battlefield Functional Area Control Systems (BFACS) to process three categories of information. The five BFACS include: fire support, intelligence and electronic warfare, maneuver control (described in subsection 9 of this chapter), air defense and combat service support (Figure 1). The three categories of information processed on the battlefield are technical, staff and command. ATCCS processes data received from sources across the battlefield. ATCCS redundant and common data base capabilities permit the force level commander to operate from anywhere within his area of responsibility. [Ref. 7]

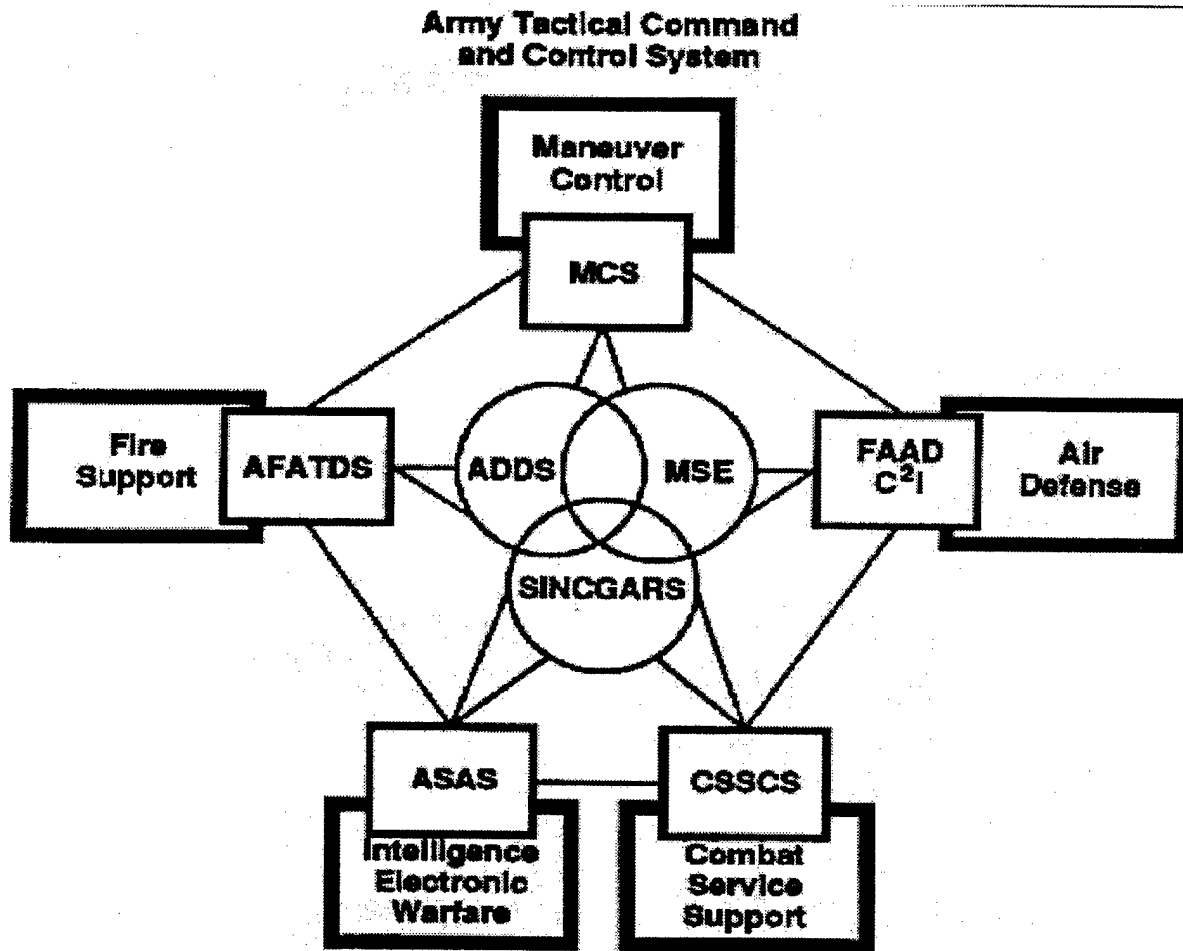

Figure 1 Army Tactical Command and Control System [Ref. 7]

3. All Source Analysis System

The All Source Analysis System (ASAS) is the Army's portion of the Joint Tactical Fusion Program, a joint Army and Air Force program to automate the correlation and analysis of high volume, time-sensitive, intelligence data. ASAS automates the fusion of intelligence and combat information on the types of enemy units and process information on their locations, movements and protected capabilities and intentions. It also automates data analysis, provides a coherent picture of the enemy situation and disseminates this information to commanders. Table 1 shows the ASAS functional capabilities. [Ref. 8]

ASAS FUNCTIONAL CAPABILITES	
Function	Capabilities
Database	<ul style="list-style-type: none"> - Automatic correlation of intelligence information to create an all source database. - Event alarms based on certain database updates that triggers auto-retrieval of information for other applications. - Timer-based queries.
Situation Display	<ul style="list-style-type: none"> - Friendly/enemy database. - Interactive tools to support threat integration, collection management, battle damage assessment, and force protection.
Situation / Event Planning	<ul style="list-style-type: none"> - Auto-notification of threat and high interest events. - Displays areas of interest, trafficability areas, avenues of approach, and mobility corridors.
Target Planning	<ul style="list-style-type: none"> - Creates and maintains target databases. - Alarms for high priority high value units.
Message Dissemination	<ul style="list-style-type: none"> - Automatic message parsing and routing. - Automatic message generation and release. - Interactive message generation, edit, and review.

Table 1 All Source Analysis System Functional Capabilities [Ref. 8]

ASAS is a tactically deployable system providing the capability to receive and correlate data from strategic and tactical intelligence sensors/sources, produce ground battle situation displays, rapidly disseminate intelligence information, provide target nominations, help manage organic intelligence and electronic warfare assets and assist in providing operations security support. ASAS is theater independent and designed to operation in peace-time, contingency, crisis, and low and high-intensity wartime environments.

The system consists of three subsystems: the Analysis and Control Element (ACE); G2 Tactical Operations Center (G2-TOC); and the Remote Workstation (RWS).

4. Forward Area Air Defense Command, Control and Intelligence

The Army's FAAD C2I system is used to automate the command and control of short-range air defense weapons. It supports the FAAD battalion mission by providing C2 information to higher, adjacent, and lower units. FAAD C2I detects, identifies, processes and instantly disseminates information on enemy and friendly aircraft to forward area air defense units. It consists of four components: 1) the automated command and control computer, 2) the ground based sensor, 3) an airborne sensor called the masked target sensor and 4) an aircraft identification element. [Ref. 8]

FAAD C2I integrates air defense (AD) fire units, sensors and C2 centers into a coherent system capable of defeating/denying the low altitude aerial threat (Unmanned Aerial Vehicles (UAVs), helicopters, etc.). It provides the automated interface (corps and below) for the AD control segments to the ABCS and allows commanders and staff to communicate, plan, coordinate, direct and control the counter-air fight. The system provides rapid collection, storage, processing, display and dissemination of critical, time-sensitive situational awareness (air and ground) and battle command information throughout the FAAD battalion and between other AD, Army, joint and combined elements. FAAD C2I provides the third dimension situational awareness component of the force level information (FLI) database. [Ref. 9]

The FAAD C2I system consists of processors, displays, software and communications equipment to meet the C2 and targeting needs of FAAD battalions and separate batteries. Computer displays allow commanders to access databases for the air picture, situation reports, enemy assessments, friendly force status and maneuver control.

The amount of database access varies at each FAAD echelon. The system provides an embedded training simulation capability that will replicate those situations encountered in actual mission operation. Figure 2 shows the connectivity with the FAAD C2I system. [Ref. 9]

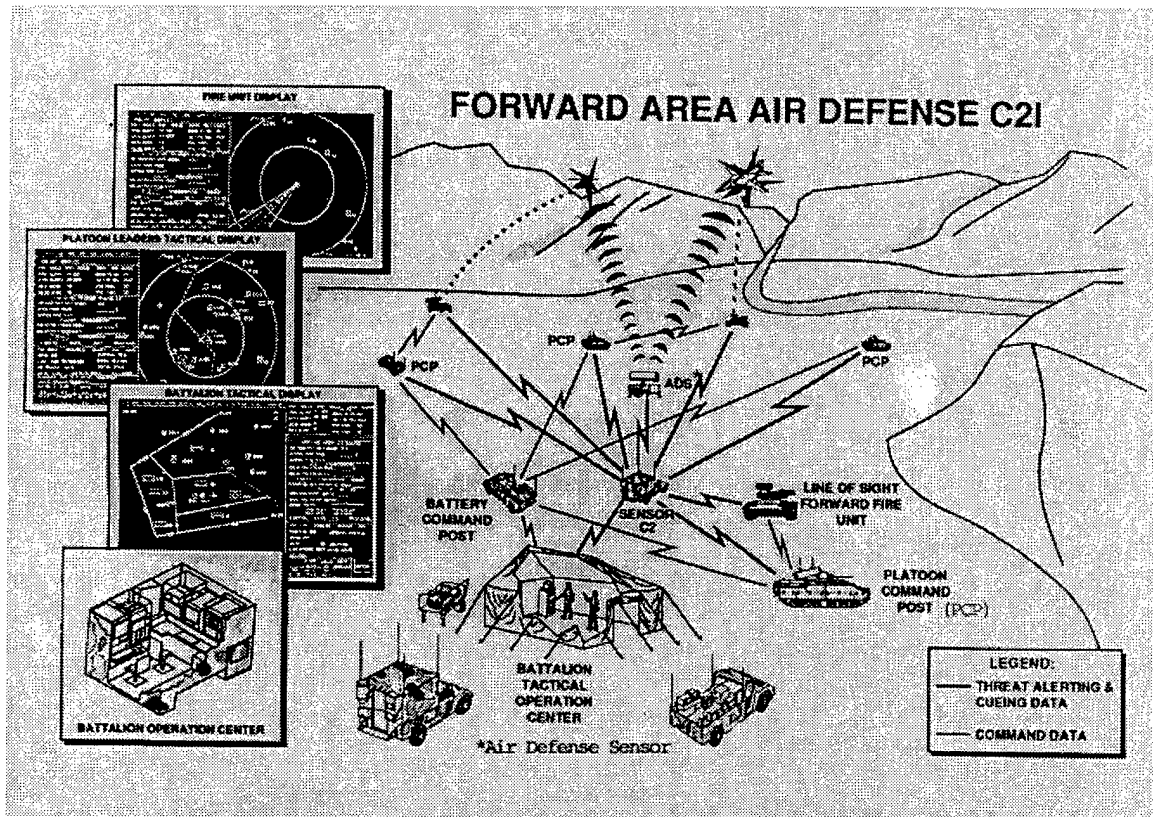

Figure 2 FAAD Connectivity [Ref. 9]

5. Maneuver Control System

The Army's Maneuver Control System (MCS), one of the BFACS in ATCCS, is an automated system composed of workstations interconnected by coaxial cables into a local area network (LAN) or through telephones connected to the Mobile Subscribe Equipment (MSE) network. These terminals allow users to transmit, access or query battlefield information either locally or from remote locations. MCS terminals are

typically located in Tactical Operations Centers (TOCs) at the battalion through corps levels. They support the exchange of near real-time tactical information such as friendly and enemy positions. The system's graphical display provides commanders with an up-to-date picture of the battlefield. [Ref. 10 and Ref. 11]

MCS displays and distributes critical tactical battlefield information for commanders. Display capabilities provide commanders with decision support aids including situation reports, intelligence reports, enemy contact reports assessing enemy strength and movements and reports detailing status of friendly forces. These decision supports aids can then be used to produce and distribute critical battlefield information. Additionally, MCS can request intelligence, supply status, air operations and fire support information from other BFACS. As part of the ATCCS, MCS uses the Communications Hub to provide commanders at all levels with a common operational picture of the battlefield that facilitates synchronization. [Ref. 12]

6. Standard Theater Army Command and Control System

The Standard Theater Army Command and Control System (STACCS) is a theater level C4I system that provides users with accurate information on friendly and hostile force activities. Users of this system are normally theater Army commanders and staffs, Army component headquarters and major command levels. STACCS connects its users' LANs to form a single Wide Area Network (WAN). The WAN gives commanders the capability to readily access and exchange critical information needed to support tactical decision making and order dissemination. This information generally includes

theater level communications status, staging area activities, force movement and resource availability status.

STACCS uses common hardware components and a common software operating system that supports an open system architecture which can be easily tailored to support specific C2 functional requirements. Some of these functions are listed below.

- Graphics presentation
- Database management
- File management
- Message processing and control
- Common network management
- Gateway connectivity to other networks

The system is completely interoperable with the MCS used at Echelons Corps and Below (ECB). This connectivity allows high level commander to acquire timely tactical information needed to remain abreast of the tactical situation and exercise effective C2 over widely dispersed theater assets. The Army plans to standardize the STACCS basic system architecture (excluding the tailoring of command unique functions) for use in theaters world-wide. [Ref. 13]

C. JOINT

1. Joint Tactical Information Distribution System

The Joint Tactical Information Distribution System (JTIDS) is a high capacity, high speed, spread spectrum information distribution system to provide Air Force, Army, Navy and Marine Corps units with secure, jam resistant, low probability of exploitation

tactical data and voice communications. It provides precise Tactical Aids to Navigation (TACAN), relative navigation and identification, and has additional capabilities for common grid navigation. It also uses the automatic relay capability inherent in the long range high frequency communications equipment. The system is interoperable among the four services and NATO. It is the follow-on to the Naval Tactical Distribution System, which is described in Section D of this Chapter. [Ref. 14]

D. NAVY AND MARINE CORPS

1. Joint Maritime Command Information System

The Joint Maritime Command Information System (JMCIS) is the primary C4I system in the Navy. It assists both Naval flag and unit commanders in performing mission data analysis requirements. JMCIS is an open client-server architecture that consists of UNIX workstations connected to a LAN. The workstations allow users to query a centralized database for specific information. The system supplies them with a fused tactical picture of the battlespace, integrated intelligence processing services and imagery exploitation capabilities. [Ref. 15]

JMICS is designed to eliminate specialized computer and unique software, and to help adopt standard software and computer hardware in line with DoD policy. JMCIS is an operational C2 system providing tactical C4I planning, execution and supervision support for all warfare areas. It supports the C4I mission requirements of joint, Navy and Marine Corps commanders, as well as facilitating information exchange with national, joint and theater level commands. It also provides timely, accurate, and complete all-source information management, display and dissemination capabilities. The core system

of JMCIS is the Unified Build (UB) software, which is the fundamental building block for all Navy tactical C2 applications software. [Ref. 14]

2. Navy Tactical Data System

The Navy Tactical Data System (NTDS) is an automated combat direction system developed in 1961 to address the anti-air warfare problem by automating the shipboard combat information center (CIC). NTDS is presently aboard more than 200 active ships in the fleet. The system is designed to display the overall tactical situation and pass information by data link between participating units to present a shared real-time display to support rapid decisions. NTDS processes tactical and selected intelligence data received from onboard sensors, surface task force sensors and airborne sensors. NTDS is supported by Link 11 / Tactical Digital Information Link (TADIL) A, Link 16 / TADIL J, as well as intra-task force tactical voice and teletype circuits for related C2 functions. The TADILs will be described in detail in Chapter III. [Ref. 7]

III THE GLOBAL COMMAND AND CONTROL SYSTEM

The preceding Chapter discussed current situational awareness systems available to commanders. This Chapter discusses GCCS. First background is provided followed by discussions on midterm fixes, DII, COE, COP, level of detail, reporting procedures, track reporting and track fusion as they relate to GCCS and the warrior's COP.

A. C4I FOR THE WARRIOR

The Command, Control, Communications, Computers and Intelligence for the Warrior (C4IFTW) concept developed by the Joint Staff provides the overall joint vision necessary to focus the independent efforts of each service toward a series of common objectives. The concept was introduced to address the difficulties that arose because existing C4I resources provided insufficient interoperability. Many of these systems were designed and developed to meet individual CINC and service organizational structures and mission needs. These systems effectively support the stovepipe, hierarchical, vertical military chain of command. However, they were not designed to support a fully integrated joint force operation and are therefore limited when information requirements are generated by horizontally integrated requirements. [Ref. 16]

The primary goal of the C4IFTW concept is to support the CINCs and CJTFs with fused real-time information that provides a true picture of the battlespace. This information not only provides warfighters with timely and relevant battlespace information, but also enhances their ability to coordinate horizontally and vertically with other organizations during the prosecution of the assigned missions. The concept acts as a roadmap for integrating the warfighter's critical functions into a common C4I system by

improving interoperability between the services, taking advantage of commercial-off-the-shelf technology and providing maximum flexibility in joint force composition.

The three main components of the C4IFTW concept are the warrior's terminal, the warrior's battlespace and the infosphere. The warrior's terminal is the composition of hardware and software that gives the warrior multimedia connectivity and access to fused battlespace information. These terminals perform a variety of functions to support the warfighters specific C2 requirements including:

- Information storage and sharing
- Artificial intelligence and decision making tools
- Wargaming
- Simulation
- Multi-level security
- Tactical picture displays
- Interoperability and communication support [Ref. 1 and Ref. 17]

The warrior's battlespace refers to the area where the warrior exercises control or military interest. Warriors, operating within their battlespace, require a fused tactical picture that represents the integration of air, sea and land forces, opposing forces and environmental factors which affect the battlespace. This dictates that information be fused into a common operating environment that can be exchanged with other C4I systems. By using approved standards, protocols and interfaces, interoperability between existing systems is now possible.

The infosphere is a global C4I network that forms a seamless communication architecture. It will provide the warfighter with immediate access to a central repository

of information at anytime and from anywhere. By having access to this information, warriors can extract only the information needed to make timely decisions. Depending on the commander's desires, the infosphere may automatically update the warrior's database as the centralized database is changed or altered by sensors and other input systems. The warfighter will be able to "pull" information, as needed, from the global infosphere and be "pushed" or automatically provided selected information updates from consolidated databases. [Ref. 6]

B. MIDTERM FIX

The World-Wide Military Command and Control System (WWMCCS), a mainframe system based on 1970's technology, has long been the strategic C2 system. During the 1980's, DoD undertook a large scale effort using classical acquisition strategies to upgrade the existing system with new technologies. The approach proved cumbersome, while warfighter needs still were increasingly unfulfilled.

In September 1992, the Under Secretary of Defense (Acquisition and Technology) terminated the WWMCCS Automated Data Processing Modernization (WAM) Program. He directed that a new acquisition approach be used to fulfill critical command and control mission needs. The Assistant Secretary of Defense (C4I) subsequently established GCCS as the principle migration path for defense-wide C2 systems. He also directed that GCCS rapidly and efficiently deliver to combatant commanders C2 capabilities through maximum use of commercial off-the-shelf (COTS) and government off-the-shelf (GOTS) components. GCCS is the midterm solution for the C4IFTW concept. Figure 3 shows the steps leading to GCCS.

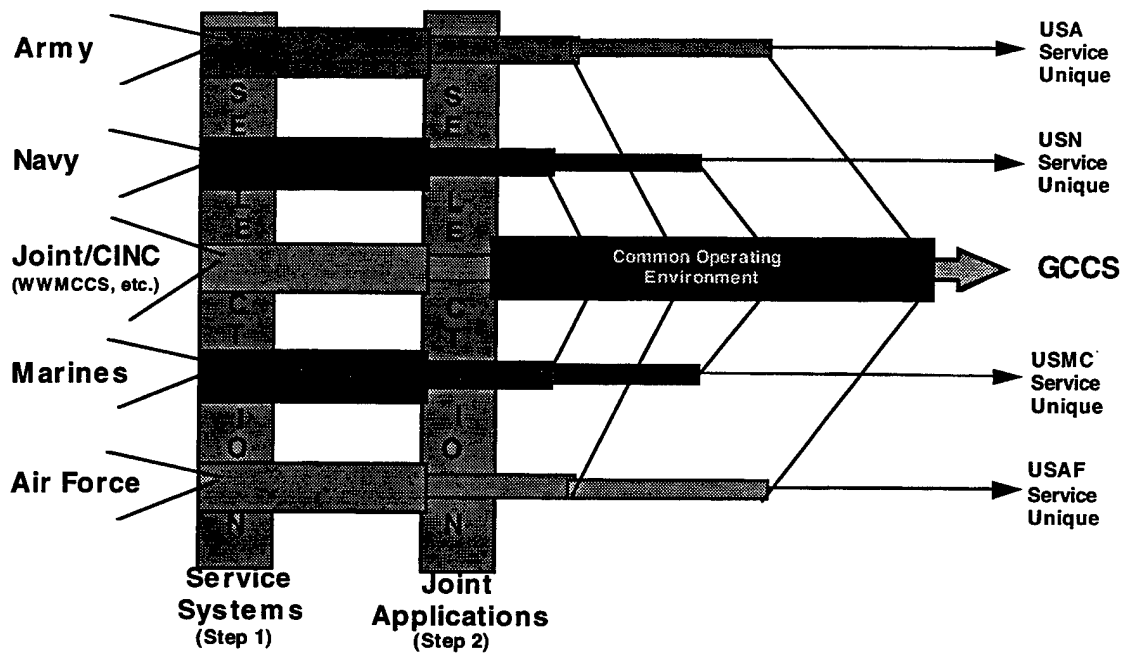

Figure 3 Global Command and Control System Migration [Ref. 18]

GCCS includes software applications operating on compatible hardware with networked connectivity that support sharing, displaying, and passing of information and databases; all operating at the SECRET level. The GCCS infrastructure consists of a client server environment incorporating UNIX-based servers and client terminals as well as personal computer X-terminal workstations that operate on a standard LAN. The infrastructure supports a communication capability providing data transfer among workstations and servers. The connectivity between GCCS sites is primarily by the Secret Internet Protocol Router Network (SIPRNET), the SECRET level of the Defense Information System Network (DISN), as shown in Figure 4. Remote user access is also

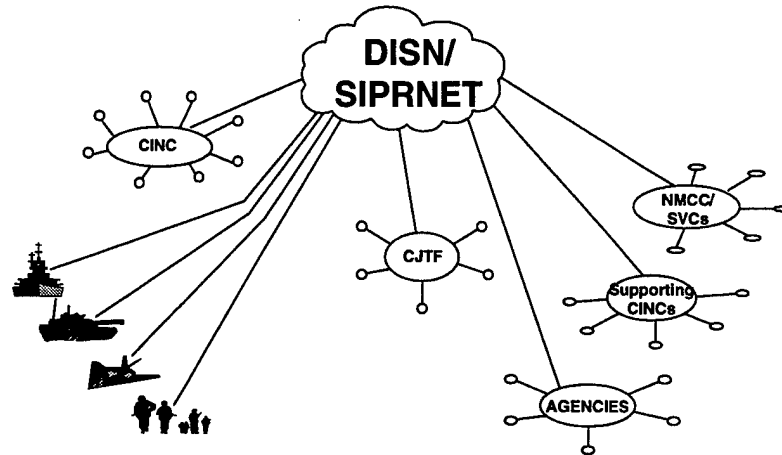

Figure 4 Global Command and Control System Connectivity [Ref. 19]

available via dial-in communications servers, or via TELNET from remote SIPRNET nodes. [Ref. 19]

C. DEFENSE INFORMATION INFRASTRUCTURE

The Defense Information Infrastructure (DII) concept is that of a seamless, global, standards-based end-to-end architecture that provides assured, flexible and affordable information services to the warfighter. The DII encompasses information transfer and processing resources, including information and data storage, manipulation, retrieval and display. The DII is the shared or interconnected system of computers, communications, data, applications, security, people, training and other support structure servicing the Department of Defense's local and worldwide needs. The DII performs two primary missions. First, it connects DoD mission support, command and control and intelligence

computers and users through voice, data, imagery, video and multimedia services; and second, it also provides information processing and value-added services to subscribers over DISN. Figure 5 depicts the key elements of the concept for C4I support of military operations. These elements consists of concepts for the C4IFTW, DISN, GCCS and Global Grid programs. [Ref. 20]

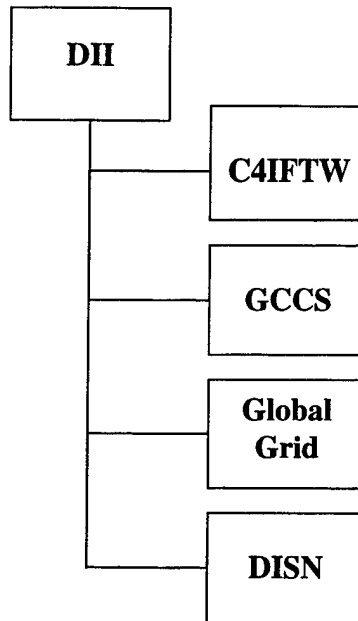

Figure 5 Defense Information Infrastructure Elements [Ref. 14]

D. COMMON OPERATING ENVIRONMENT

The Common Operating Environment (COE) will make maximum use of COTS, particularly in those areas of the COE most widely used across the DII subscriber community. The COE minimizes interoperability issues or identifies up-front the costs associated with achieving interoperability to DoD based on inclusion of a particular product. In fact, the COE provides the only systematic approach to providing a common

infrastructure across the DII on which system developers, engineers, and integrators can confidently build with the goal of achieving system interoperability and the vision of C4IFTW.

The COE is a collection of building blocks (segments) which form a software "backplane". Segments "plug" into the COE just as circuit cards plug into a hardware backplane. The blocks containing the operating system and windowing environment are akin to a power supply as they contain the software which "powers" the rest of the system. The segments labeled as COE component segments are equivalent to pre-built boards such as the central processing unit (CPU) or memory cards. Some of them are required (e.g., CPU) while others are optional (e.g., specialized communications interface cards) depending upon how the system being built will be used. Mission application segments are equivalent to adding custom circuit cards to the backplane to make the system suitable for a more tailored purpose.

The COE is further defined in terms of a layered software architecture. Its present definition consists of three layers driven by increasing levels of system interoperability as one moves up the taxonomy (increasing the level of system compliance with the COE). These layers are: the Kernel, Infrastructure Services, and Common Support Applications. The Kernel is the minimum set of software required on every DII platform regardless of how that platform will be used. The Kernel lays the basis for integration of the remainder of the COE and is the first step in achieving system and component interoperability.

Infrastructure Services provide the low level tools necessary for data exchange. These services provide the architectural framework for managing and distributing the flow of data throughout a DII-based system and are, in general, COTS products.

Common Support Applications provide for common data understanding or information exchange. This level contains facilities for processing and displaying common data formats, and for information integration and visualization. Services in this layer tend to be mission domain specific and are, in general, government developed. Table 2 shows the relationships in the COE. [Ref. 20]

DoD Applications: Air Force, Army, Navy, Marines				
Standard Application Program Interfaces				
Common Support Applications				
Alerts	MCG&I	Message Processing	Office Automation	On-Line Help
Correlation	Logistics Analysis			
<-----	Other Support	Applications	As Required	----->
Infrastructure Services				
Management Services	Communications Services	Data Management Services	Distributed Services and Object Management	Presentation Services
<-----Other	Infrastructure	Services	As Required ---	----->
Kernel/Operating System				

Table 2 Common Operating Environment Relationship [Ref. 17]

E. COMMON OPERATIONAL PICTURE

The term GCCS Common Operational Picture (COP) refers to the near real time display of known friendly, neutral, and enemy ground, maritime and air units displayed on a GCCS terminal. The Joint Staff, CINCs, Commander Joint Task Force (CJTF), Joint Task Force components, service components, and logistics and supporting units all share the common picture. The COP provides these elements and other supporting forces with a common awareness of the location of enemy and friendly forces and as well as other

relevant objects. It also provides information on environmental conditions within the area of operations. The CINC can provide a broadcast of the COP to the Joint Staff as required, and to forces outside the theater.

DISA selected the Navy's JMCIS, described in Chapter II, as the "best of breed" to provide the common operational picture for GCCS. The COP uses a single relational database structure common to all DII COE users; additionally, it is a kernel function of GCCS. This common data baseline provides the afloat, ashore, and joint commanders with a single, integrated C2 system that receives, processes, displays and maintains geo-location information on all forces. It supports the warfighting commander's need for an overarching operational picture. [Ref. 19]

The CINCs define, maintain and control the information in their AORs. Each CINC will designate the build of the COP responsibility for each respective AOR. Therefore, combatant commanders have overall responsibility for maintenance of the COP within their theaters. They will determine the most appropriate arrangement for distribution of the COP from a JTF or AOR to the Joint Staff and supporting commands. In addition to ensuring the Chairman of the Joint Chiefs of Staff (CJCS) reporting requirements are met, they may also specify additional theater requirements. [Ref. 16]

F. LEVEL OF DETAIL

The level of detail of the COP consists of two elements, information level and force level. Information level refers to the hierarchy of COP information and consists of the following categories: essential, necessary, additive, enhanced or extraneous. Force level information refers to the reported force size that is reported in the following

categories: high interest tracks, major combat elements, major aviation units, SOF forces and major forces.

The purpose of the reporting procedures (discussed in section G of this chapter) is to build an accurate COP including the current representation of the battlespace or Common Tactical Picture (CTP). The COP must be sufficiently complete to satisfy commanders covering the whole spectrum from the NMCC to the CJTF. The system must be flexible enough to allow for differences in organizational structures, situational variances caused by the operation at hand, and different operating styles of each commander. Hence, each commander has the responsibility to designate the appropriate level of information and the force levels ensuring the COP accurately displays the current situation. The fusion center (described in section I of this chapter) will play a key role in providing the level of detail to build an accurate COP. Level of detail is situational dependent. [Ref. 16]

The COP should become a standard reporting tool for the full spectrum of any force engagement and at all levels of operations and war. Examples of operations include conditions warranting the establishment of a Joint Task Force (JTF), crisis situations, joint field exercises and normal daily operations. The levels of war include strategic, operational and tactical. The COP must become an integral facet of the command and control process. Therefore, use of the COP on a daily basis, as well as for JTF exercises is necessary to ensure proficiency and continued development.

At each level of command, units must enter into their COP the data needed for command and control. Commanders at each level must determine what those needs are. Normally, the ground component will report information two echelons below the ground

component's headquarters. For example, if the ground component headquarters is an Army Corps, then division and brigade formations should be displayed as separate icons. Each command level will transmit data in accordance with their higher headquarters C2 needs. The higher headquarters is responsible for specifying what those needs are. Subordinate units then send only the data that meets their higher headquarters needs. Subordinate commanders should still send unrequested data to the higher commander for the overall success of the mission. Hence, each commander has the responsibility to designate the appropriate level of information and the force levels insuring the COP accurately displays the current situation.

The CINC will determine what type of data the component and subordinate commands must submit. As general guidance, the following data should be reported, as a minimum:

1. Army and Marine Corps

- (1) Unit Headquarters Brigade-level and higher.
- (2) Base camp locations.
- (3) Operational graphics showing Corps and Division boundaries.
- (4) Locations from organic sensors of enemy, neutral and other organizations

2. Air Force

Since the majority of the data will enter the COP through TADIL B and TADIL J, the level of detail will be down to the individual aircraft. The data will be transmitted by the Airborne Warning and Control System (AWACS) aircraft. Additionally, major combat elements, by type, when not airborne should also be reported.

3. Navy

Ships report their location to the Battle Group Commander, who serves as the Force Over-the-Horizon (OTH) Track Coordinator (FOTC). FOTC is the track fusion center for the battle group. The FOTC has a JMCIS system that can correlate and add or delete these track positions. Once correlated, the Officer in Tactical Command Information System (OTCIXS) will broadcast the positions to the naval component commander. The FOTC role is primarily to coordinate the maritime picture (to include all know air, surface and subsurface contacts and address its accuracy. [Ref. 21]

G. REPORTING PROCEDURES

A basic principle of the COP is that CINCs will task subordinate organizations as data managers for different types of data information. Commanders will base these taskings on the organization's areas of responsibility, their operational missions, and their reporting capabilities. For example, the air, maritime and ground component commanders will provide their respective component unit and/or track positions. Exceptions in reporting, e.g., air tracks from the Navy, can occur depending on the nature of the operation. These organizations are responsible for entering, updating and maintaining their assigned tracks using existing automated or manual tools.

Reporting organizations will identify and enter tracks into the system through any of three methods: 1) those detected by sensors and automatically reported, 2) those units that automatically report their position and status or 3) those manually entered. Reporting organizations also will perform track maintenance to remove redundant tracks by merging

existing tracks or units that are already in the data base. Each organization is responsible for providing information to a designated COP integration site. [Ref. 21]

The information provided will either be a track or a force location. A track is any force of any size within the AOR. An example of a track is a ship transiting through a straight. A force is a track at a fixed location, either garrison, headquarters or operating position of any component of any size. For example the headquarters of a wing, battalion or a ship at port. The following 5 sections discuss each components responsibility in reporting tracks to their commander.

1. Air Component

Air components report the daily location of major aviation units by type to the commander when they are not airborne. They also report all known aircraft in the area of interest that are part of the recognized air picture, as well as the location of major aviation units by type when not airborne. This normally will be the garrison location of major aviation units at the squadron level or above. Additionally, they report high interest tracks (VIPs, special missions, special interest) operating within the normal area of responsibility for the respective COP. Lastly, they report the location of major aviation units within the AOR. [Ref. 16]

2. Ground Component

Ground components report only units that are in the area of interest. Ground components will report the current location of all known ground units within their battlespace. The positions should be updated when units move and as data becomes available. Normally the ground component will report ground units two echelons below

the level of the Ground Component Commander. Organizations that must report ground units to the CINC will report brigade-level and higher echelons. The ground component may report units other than military forces if they feel the information is relevant to the mission. Additionally, the component commander reports friendly, hostile, and neutral ground units within the area of interest down to the major combat element size and information level desired by the commander. Units report their current positions, and update as they move. Ground components report major combat elements.

3. Naval Component

Naval components report the location of Battle Group and Amphibious Ready Groups (ARGs) units. They also report other nations' ships when conducting out of area operations or when appropriate. This is usually all contacts in the JMCIS database. The naval components also report all known maritime tracks within the area of interest with the proper level of detail desired by the commander.

4. Joint Special Operation Task Forces Commander

The Joint Special Operation Force (SOF) Commander (or Commander JSOTF) provides location data (when classification permits) that details the location of SOF forces when SOF forces operate within an AOR. When providing this information, the SOF Commander is responsible for track management of SOF forces. The CINC may also direct the JSOTF to report positions of SOF units down to team level whenever their employment is of operational and strategic importance. Additionally, the CINC may direct reporting of paramilitary units or units other than military forces if they are relevant to the situation. [Ref. 21]

5. Special Interest Forces and Tracks

Special interest tracks and forces include tracks, regardless of size or composition, of special importance that are key to an operation, linked to major negotiations, have national level interest, and may involve the NCA. Examples of this include search and rescue operations, humanitarian assistance forces, activities surrounding mishaps, travel of VIPs, freedom of navigation operations and of forces in high interest peace keeping operations. [Ref. 16]

H. TRACK REPORTING

Tracks are received and transmitted using various means. Table 3 shows the manner in which each service receives and transmits track data.

The tracks are reported to commanders using one of the following means:

1. Enhanced Position Location Reporting System

The Enhanced Position Location Reporting System (EPLRS) is a secure, contention-free data communications system that tactical commanders and staff use to report a unit's identification, location and navigation information. EPLRS supports the exchange of real-time C2 information by using a geographically dispersed network of secure Ultra High Frequency (UHF) radio relay links between net control stations and user terminals. Although EPLRS was designed as an autonomous system, it can interface with the Marine Corps' Position Location Reporting System (PLRS) and the Army's Force XXI Battle Command Brigade and Below System (FBCB2), described in Chapter IV. [Ref. 22]

	ARMY	NAVY	AIR FORCE	MARINE
EPLRS / PLRS	X			X
OTCIXS		X	X	X
SABER				X
TADIL A		X		X
TADIL B			X	X
TADIL J		X	X	X
TIBS		X	X	
TRI-TAC	X			X
TRAP		R	R	
R - Receive X - Transmit and Receive				

Table 3 Track Reporting Methods

2. Officer in Tactical Command Information Exchange System

The Officer in Tactical Command Information Exchange System (OTCIXS) is a formatted broadcast system providing naval force position data and messaging capability.

[Ref. 16]

3. Situational Awareness Beacon with Reply

Situation Awareness Beacon with Reply (SABER) is a leading edge technology development that uses capabilities of space systems to help reduce battlefield fratricide. Using a small transceiver, Global Positioning System (GPS) receiver and simple packaging scheme, SABER enables a platform to report its position automatically through UHF line of site or UHF SATCOM. [Ref. 23]

4. Tactical Digital Information Links

The Tactical Digital Information Links (TADILs) consist of a family of JCS approved standardized communications links suitable for transmission of digital information. TADILs are characterized by standardized message formats and transmission characteristics. These standardized provide a readily acceptable communications format for the cross-flow of information between services and allies.

a. TADILA / LINK 11

TADIL A or Link 11 is a two-way, real-time, encrypted digital link that utilized high frequency (HF) and UHF communications circuits, as well as shipboard UHF satellite circuits. TADIL A primarily supports NTDS. TADIL A is operated in a roll-call mode under control of a net control station, the information is exchange digitally among airborne, land-based and shipboard systems.

b. TADIL B

TADIL B is a point-to-point digital data link that connects land-based tactical air defense and air control units. It is a secure, full-duplex digital link. This data link interconnects tactical air defense and air control units.

c. TADIL J

TADIL J or Link 16 is a secure high capacity, jam-resistant, node-less data link that uses the JTIDS transmission characteristics. Currently limited to UHF transmissions (with an UHF relay capability), it provides extensive amplifying track data. It provides real-time exchange of tactical digital information between major C2 systems for the United States and NATO allies. This information will be used by ground, naval and airborne units. JTIDS information is broadcast omnidirectionally at many thousands of bits each second and can be received by any terminal within range. Information flows directly from many transmitters to many receivers using a frequency-hopped, time-sequenced transmission scheme. Each terminal, ground or airborne, can select or reject each message according to its need. [Ref. 7]

5. Tactical Information Broadcast System

Tactical Information Broadcast System (TIBS) is a formatted satellite broadcast system, delivering air and ELINT track data. TIBS air data will occasionally provide amplifying track data like course, speed and altitude.

6. Tactical Related Applications

Tactical Related Applications (TRAP) is a formatted satellite broadcast system, delivering a variety of nationally collected correlated data. [Ref. 16]

7. TRI-Service Tactical Communications System

The Tri-Service Tactical Communications System (TRI-TAC) is the Army, Air Force and Marine Corps digital secure theater communications support system. It provides connectivity and communications support to the corps Tactical Operations Centers (TOC), major commands, Army component headquarters and JTF headquarters. The network architecture is composed of a series of circuit and message switches arranged in a grid-like pattern. Interconnectivity is achieved by using UHF or UHF SATCOM. [Ref. 6 and Ref. 24]

I. TRACK FUSION

Track fusion is the process of receiving and integrating all-source, multifunction information to produce and make available an accurate, complete and timely comprehensive tactical picture of the disposition of all known surface, subsurface, air and land based units. Track managers determined which reports go with what tracks during the fusion process. Track managers for each component, air, land or sea have the responsibility for management of their own particular types of track based on some combination of AOR, attributes and sensors. The theater track manager conducts track fusion for the COP for the CINC. The CINC then directs the dissemination of the fused picture.

In the GCCS COP, track managers fuse contact reports from remote units into tracks. The tracks may contain multiple contact reports from one or more distinctive units. The track manager appends an identifying track number to each track update report. This allows the updated track to associate with other contacts that are actually the same track. This results in the fusion of contacts from remote sensors with contacts generated by organic or dedicated sensors. As contact reports accumulate and the organization's track manager correlates them into tracks, they become that organization's track data base. This is the common operational picture held by all units of that organization. The fusion center, the location where the above process is performed, will play a key role in providing the level of detail sufficient to build an accurate COP. Level of detail will be situational dependent. [Ref. 16]

Components are responsible for all source data correlation and fusion within their reporting responsibility. They also have responsibility for ensuring the data is sent to the GCCS COP using one of the means in Section F of this chapter. Only the component that is responsible for reporting a track can manage that track. Track management requires that only the reporting authority can delete the track, or merge it with another. The only exception to this policy is the theater track manager, who may merge or delete any track at any time. Data injection or track management from outside the AOR is not allowed without the approval of the theater track manager. For example, a CINC can task the Joint Intelligence Center (JIC) or Regional Signal Intelligence (SIGINT) Operations Center (RSOC) to provide the CINC with correlated all source Intel data that could supplement, modify or replace tracks being managed by a component. When done, the tasked unit

would then send the data to the responsible CINC component for integration into the GCCS COP. [Ref. 19]

1. Joint Force Commander

The JFC becomes the primary track manager and fusion center for the COP upon JTF establishment. The JFC is responsible for the COP within his Joint Operational Area (JOA). This function may pass to either the CINC or to one of the JTF components depending upon the geographic situation and communications availability. Additionally, the JFC also ensures that all the component commanders are responsible for:

- 1) Fusion of organic and non-organic ground, naval and air track data prior to its injection into the COP.
- 2) The deletion of tracks which have left the AOR, or are not valid.

2. Air Component Commander

The Air Component Commander (ACC) Track Manager is normally responsible for reporting airborne contacts at altitudes from the surface up to 100,000 feet. A Maritime Component Commander Track Manager may have to manage the air picture for airborne contacts operating over water outside of the ACC's responsibility. The JFC will correlate air tracks that have been reported by both component commanders.

3. Ground Component Commander

The Ground Component Commander (GCC) Track Manager is normally responsible for reporting and data base management for all ground tracks at least two echelons below its own command level, unless more detail is necessary.

4. Maritime Component Commander

The Maritime Component Commander (MCC) Track Manager is normally responsible for reporting all maritime contacts. Depending upon the AOR and tactical situation, the MCC will also manage the air picture for airborne tracks over water. [Ref. 21]

IV CURRENT EFFORTS

The previous chapters discussed current common operational picture systems available to the commander and GCCS. This chapter will discuss current efforts of the services to bring the COP to all levels of command.

Currently there is an over abundance of systems being developed to bring the common operational picture to all levels of command. These emerging systems are not fully integrated throughout the DoD, but initial delivery to the services has begun. While all are DII COE compliant, none use the GCCS COP as the basis. The services are either developing new systems or modifying or update current systems to bring the common operational picture to lower levels of command. The following is a brief description of the primary systems each service is developing.

A. AIR FORCE

On 17 Mar 95, the Air Force established the Air Force GCCS Program Office (ESC/AVN) at Hanscom AFB to improve Air Force participation in the GCCS. Since its creation, the office has become responsible for a small portion of COE development, has created GCCS laboratories at Hanscom AFB and Gunter AFB, has participated in those installation and testing efforts necessary to reach GCCS Initial Operational Capability (IOC), and has begun to assist in the migration of Air Force systems to GCCS. However, the Air Force has no current, detailed plan for increased GCCS involvement. Air Force efforts are fragmented and underfunded. [Ref. 18]

The Air Force also does not have current efforts to bring the COP to lower levels of command. While there are no new systems in development, they do have several

programs to bring JTIDS, described in Chapter II, to lower levels to include the cockpit of fighters. They do however have some future efforts that will be discussed in Chapter V.

B. ARMY

Currently the Army does not have an integrated, automated, strategic to foxhole C2 system. Commanders and staffs generally perform their mission using a manual system, augmented by commercially available software systems. Current fielded information and communication systems do not provide the mobility, functional flexible or interoperability required by the Army. These shortfalls hamper the ability to transport, collect, disseminate and display information vertically and horizontally. The Army Battlefield Command Systems, described in Chapter V, and the Army Global Command and Control System, described in this Section, are being developed to overcome these shortfalls. [Ref. 3]

The Army also currently lacks a fully functional integrated battle command system for the mounted/dismounted leader at the brigade level and below. At maneuver brigade and lower echelons, there is an inadequate capability to support information needs of the commanders at each level because units are void of battle command digital information devices and rely primarily on voice communications. Current communications systems also do not provide sufficient data throughput for current and emerging large capacity data terminals. This has impeded the ability to provide the commander real-time and near real-time usable information on which to base tactical decisions. [Ref. 25]

Additionally, the Army Tactical Command and Control System (described in Chapter II), fielded in the Tactical Operations Center (TOC) at Brigades and Battalions does not provide control functions such as sensor feeds that help reduce the risk of fratricide, improve synchronization of fires, facilitate intelligence access, provide a near real-time relevant common picture or increase force projection capabilities down to the platform. The Force XXI Battle Command - Brigade and Below System, described in this Section, is being developed to overcome this shortfall. [Ref. 25]

1. Army Global Command and Control System

The Army Global Command and Control System (AGCCS) is the Army link between ABCS and GCCS. AGCCS will provide a suite of modular applications and information and decision support to Army strategic/operational/theater operations planners. AGCCS will support the apportionment, allocation, logistical support and deployment of Army forces to the combatant commands in response to planning and policy guidance provided by the NCA during a crisis situation. Functionality includes force tracking, host nation and civil affairs support, theater air defense, targeting, psychological operations, C2, logistics, medical and personnel status. AGCCS will be deployed from theater echelon above corps (EAC) elements down to the Corps where it will link to the ATCCS. AGCCS includes STACCS, the Army Worldwide Military Command and Control System Information System (AWIS), and the EAC portion of the Combat Service Support Control System (CSSCS). [Ref. 3 and Ref. 6]

The migration of the legacy STACCS to the AGCCS will be a phased effort which addresses several key technological improvements. The two immediate priorities

are to move from obsolete hardware, and to port to the Joint Standard Defense Information Infrastructure Common Operating Environment. Further enhancements will include the transition of STACCS applications to a single integrated data model, the Army Global Database (AGDB); new technology insertion focusing on COTS software to satisfy STACCS requirements; integration of theater and strategic functional applications; expanded interfaces to include joint and future tactical systems; and, major improvements to the data replication/distribution methodology. All these enhancements will be achieved in an evolutionary manner through a number of AGCCS deliveries. [Ref. 11]

2. Force XXI Battle Command, Brigade and Below

The Army's Force XXI Battle Command, Brigade and Below System (FBCB2) is a suite of digitally interoperable, battlefield operating systems (BOS) specific, functional applications, designed to provide real-time and near real-time situational information to tactical combat, combat support and combat service support leaders to the platform and soldier level. FBCB2, as a key component of the ABCS, seamlessly interfaces with the ATCCS, described in Chapter II, at brigade and battalion levels. It also supports C2 down to the soldier and platform level across all battlefield functional areas and echelons. Figure 6 shows the interface between FBCB2 and other Army systems.

FBCB2 is going to provide the technology to complete the ABCS information flow process from brigade to platform across all platforms within the brigade. Additionally, FBCB2 will provide commanders the ability to remotely operate and maintain ABCS database connectivity regardless of command vehicle, and to digitally control and monitor their subordinate unit status and position. [Ref. 25]

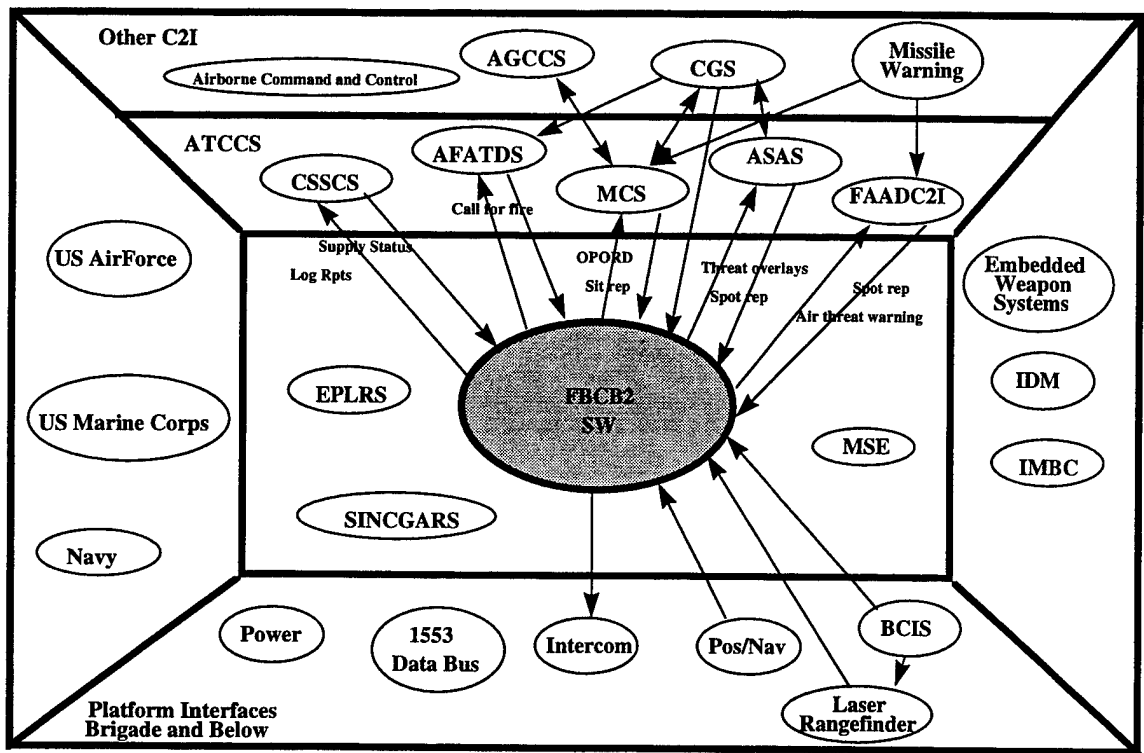

Figure 6 Force XXI Battle Command, Brigade and Below System Interface [Ref. 26]

FBCB2 populates the database with automated positional friendly information and current tactical battlefield geometry for friendly and known/suspected enemy forces. It also pulls information from the FLI database to provide commanders with situational reporting, calls for fire, close air support via graphic and textual orders. [Ref. 9]

The FBCB2 system will provide a common situational awareness picture that includes the following components:

- Standard military map
- Elevation data
- Feature and attribute data
- Own location / direction of travel, if appropriate
- Enemy locations (Vehicle/unit/soldier)
- Friendly locations

(Vehicle/unit/soldier)

- Updated terrain data
- Neutral / noncombatant locations
- Unit readiness status
- Display friendly positions horizontally within, and across boundaries, and two echelons below and two echelons up
- Enemy Obstacles
- Operational Order / Operational Plan Overlays
- Displayed icons in accordance with data received within the parameters shown in table 3

<u>TYPE ICON</u>	<u>THRESHOLD</u>	<u>OBJECTIVE</u>
Dismounted Soldier	10 Meters	1 Meter
Platform	100 Meters	10 Meters
Platoon	100 Meters Center of Mass	
Company	500 Meters Center of Mass	

Table 4 Icon Display Parameters [Ref. 25]

Additionally, the icons in FBCB2 can be changed to show the appropriate level of detail the commander desires. The system provides the ability to select individual icons and display these icons as a unit. The system also has the ability to select several units and display them as an aggregated unit (by lead element or center of mass). FBCB2 has

the ability to decompose or deaggregate a displayed unit into smaller units or individual system icons. This allows different levels to display the appropriate level of detail for the commander and mission needs. [Ref. 25]

The display of the FBCB2 will be capable of the following:

- Displaying three dimensional representations.
- Displaying colors (e.g., standard military map colors).
- Provide a picture that is visible in all operating environments and light conditions.
- Provide a picture that is visible from various angles as viewed by the operator.
- Provide a display with variable intensity and illumination that is adjustable by the operator.

Additionally, FBCB2 will have the inherent capability to access information data bases, in the push / pull mode described in Chapter III. Information pulled from databases will assist in planning and supporting military operations. FBCB2 will support and interface with existing and emerging Army C4I systems to include ATCCS. The transfer of battle command information will be automated over tactical data and voice communication systems.

Lastly, FBCB2 is scheduled to have an Initial Operational Capabilities (IOC) on or about FY00. The IOC will be attained when FBCB2 is completely interoperable within ABCS, fielded to the first combined arms maneuver brigade, fully trained (to include supporting Combat Support and Combat Service Support elements) and judged to be combat ready (to include required spares /repair parts, etc.). Full operational

capabilities will be attained when a corps set is fielded, proficient and considered combat deployable using FBCB2 equipment. [Ref. 25]

C. MARINE CORPS

The Marine Corps is currently migrating all systems to the Navy JMCIS. However, there is one system that will be described in Chapter V that is meant to give the tactical unit situational awareness that uses a DOS based program.

1. Marine Air Ground Task Force C4I

The Marine Air Ground Task Force C4I (MAGTF C4I) system, formerly the Marine Tactical Automated Command and Control System, is the concept for integrating communications and tactical data systems on the modern battlefield. The purpose of MAGTF C4I is to provide Fleet Marine Force commanders with the means to manage the complexity of the modern battlefield. MAGTF C4I will provide commanders and their staffs with the capabilities to send, receive, process, filter and display data to aid in tactical decision making. The MAGTF C4I software baseline relies on the COE resident in the evolving GCCS DII COE established by the Defense Information Systems Agency. The MAGTF C4I software baseline will be developed to ensure compatibility with the GCCS DII COE as it continues to evolve from the foundations established by the initial JMCIS-based versions. [Ref. 27]

The MAGTF C4I software is designed to support the information 'pull' concept similar to the Navy's JMCIS. This concept allows Marine commanders to access only information they need from a common database that receives periodic updates from many different input sources. Interoperability between MAGTF systems and JMCIS databases

will make it possible for users in the Navy and Marine Corps to access, exchange and update information between these systems.

As with JMCIS, the Marine Corps migration toward a single consolidated system is driven by the Assistant Secretary of Defense C3I mandate directing all of the services to eliminate their stovepipe and legacy systems to support data standardization. To fulfill this objective, the Marine Corps plans to migrate their MAGTF C4I system first into JMCIS and then later into GCCS. This required the Marine Corps to adopt common core software modules provided by the Unified Build of the GCCS as well as ensure the software is DII COE compliant. The core software provides an automated Command, Control, Communications, Decision and Display System (C3DDS) capable of interfacing across multiple communications circuits, processing standardized formatted messages, and correlating contact reports to produce a consistent track database. Track data is plotted on situation displays to create real-time tactical decision aides for both Marine and Navy commanders. [Ref. 28]

2. Tactical Combat Operations System

The Tactical Combat Operations (TCO) System will be the focal point of the MAGTF C4I network. It will provide the commanders, staffs and subordinates the capability to receive, fuse, display, and disseminate C2 information, for both planning and executing phases of an operation. The system will link the operations sections of all FMF units of battalion or squadron size and larger. Marine forces embarked aboard Navy ships will "plug in" to the JMCIS terminal. When ashore, the MAGTF C4I compliant system will allow interoperability with joint forces over internal and external communications.

TCO will be located in Combat Service Support Operations Centers (CSSOC), Operations Control and Analysis Center (OCAC), Combat Operations Centers (COC), Tactical Air Command Centers (TACC) and Fire Direction Centers (FDC). [Ref. 10]

D. NAVY

Currently, the Navy already has situational awareness on most ships at the tactical level due the JMCIS, described in Chapter II. There are however several other programs that the Navy is currently developing. While these do bring a common picture to other commands, it is a static not dynamic display. An example is the ELVIS processor. ELVIS takes the GCCS COP and takes a snapshot picture that can be transmitted over the SIPRNET. This allows units that do not have a COP but have the SIPRNET to have a common picture for a specific set time period. As a consequence of the above, the primary efforts of the Navy are to upgrade JMCIS and to develop a situational awareness system for individual of the warfare areas (air, surface or subsurface). The following section describes one of the systems that is being developed as a possible replacement for the Naval Tactical Data System, described in Chapter II, for the Force Anti-Air Warfare Commander.

1. Force Threat Evaluation and Weapons Assignment

The Force Threat Evaluation and Weapons Assignment (Force TEWA) system is being developed by the Johns Hopkins University Applied Physics Laboratory to aid the Force Anti-Air Warfare Coordinator in gaining situational awareness quicker than with the Navy Tactical Data System. Using a powerful set of computers and a unique display capability, Force TEWA takes the Link picture and displays it using sophisticated color

iconography rather than complicated symbology. In other words, a friendly air track no longer appears as a simple semicircle, leaving it up to the operator to choose the track and painstakingly determine which friendly track is chosen. With Force TEWA, this track would appear and an actual plane (F/A-18 for example). Figure 7 shows some of the icons that Force TEWA uses.

In addition, the track is displayed on a 28 inch, high-definition television screen. Another unique feature is the 3-D capability of the system. Not only does this provide a perception-aiding depth of field, but it allows the commander to examine the battlespace from any perspective. This vastly improved tactical display is easily grasped by tactical commanders, greatly simplifying their decision-making process. [Ref. 29]

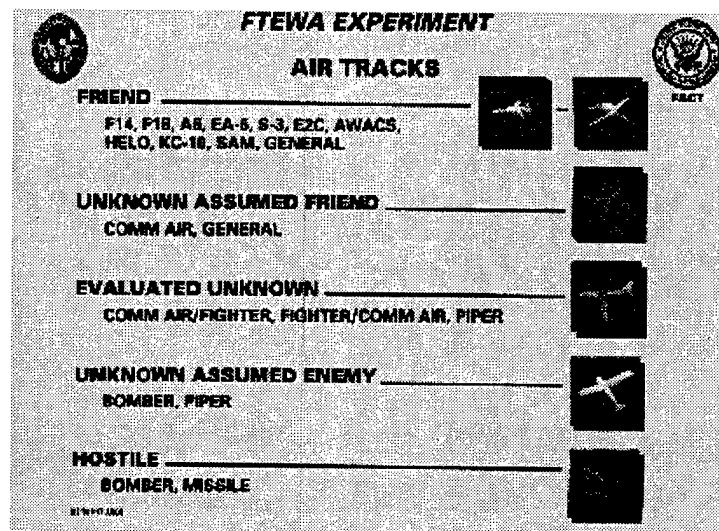

Figure 7 Force Threat Evaluation and Weapons Assignment Icons [Ref. 29]

V FUTURE EFFORTS

The previous chapters discussed current common situational picture systems available to the commander, GCCS and current efforts of the services to bring the COP to all levels of command. This chapter will discuss future efforts of the services as well as Defense Agencies. It also examines a Joint Staff study on future requirements for commanders to have a common operational picture.

A. AIR FORCE

The Air Force initiated a new program in February 1997 to bring a common picture to all levels of command. While this is currently in the initial stages, the final product could provide a common operational picture to the lower levels which is currently lacking today.

1. New World Vistas Global Awareness Virtual Testbed

The New World Vistas Global Awareness Virtual Testbed (NWV GAVTB) is being driven by the Air Force vision of dominance in the information systems sector called "Global Awareness" (GA). When fielded, it will include of a geographical display of tracks and information from a centralized data base. Its motivation is the provision of real-time situation awareness all any levels - strategic, operational and tactical.

GAVTB is envisioned to include tracks from multiple intelligence and tactical data sources that are fused into a common operational picture of the battlefield. The picture will use High Level Architecture protocols for the information dissemination to allow for interoperability with other services. Additionally, it will have advanced real-

time data and information handling, retrieval and visualization techniques that will allow a dynamic picture. The result will be a DII COE compliant system that will give the commander a true real-time common operational picture using information provided by multiple sources

The GAVTB research is also examining several different ways to aid the commander with a common operational picture that will improve situational awareness. These include a new GA architecture that allows commanders instant access to the database that contains track information, regardless of where the database is physically located. This can be seen as analogous to the tactical internet being developed for the Battlefield Awareness and Data Dissemination Advanced Concept Technology Demonstration, described later in this chapter. It also examines automated data and information retrieval and indexing methods, automated data and information dissemination for the sharing of the database information and new ways to fuse the multi-sensor track information. Finally, GAVTB explores innovative presentation techniques to give the commander the ability to gain situational awareness in a shorter time. [Ref. 30]

B. ARMY

1. Army Battlefield Command System

The goal of the Army Battlefield Command System (ABCS) is to provide a seamless C2 capability from the strategic echelon to the foxhole and also be interoperable with joint systems. It will be the tool commanders use to control the battlefield, project situations, determine requirements and capabilities, develop courses of action and

disseminate intent and orders. ABCS will result in the integration of multiple currently fielded and developmental battlefield operating systems (BOSs). The system will be capable of automated interoperability between and within the BOSs and it will automate the entry of platform inputs (i.e., position/location, status, etc.). Additionally, ABCS will also be used at all levels of command. Lastly, the DII COE will be the basis for all ABCS software and hardware. Figure 8 shows the relationship of ABCS and other Army systems. As shown, they will become part of ABCS.

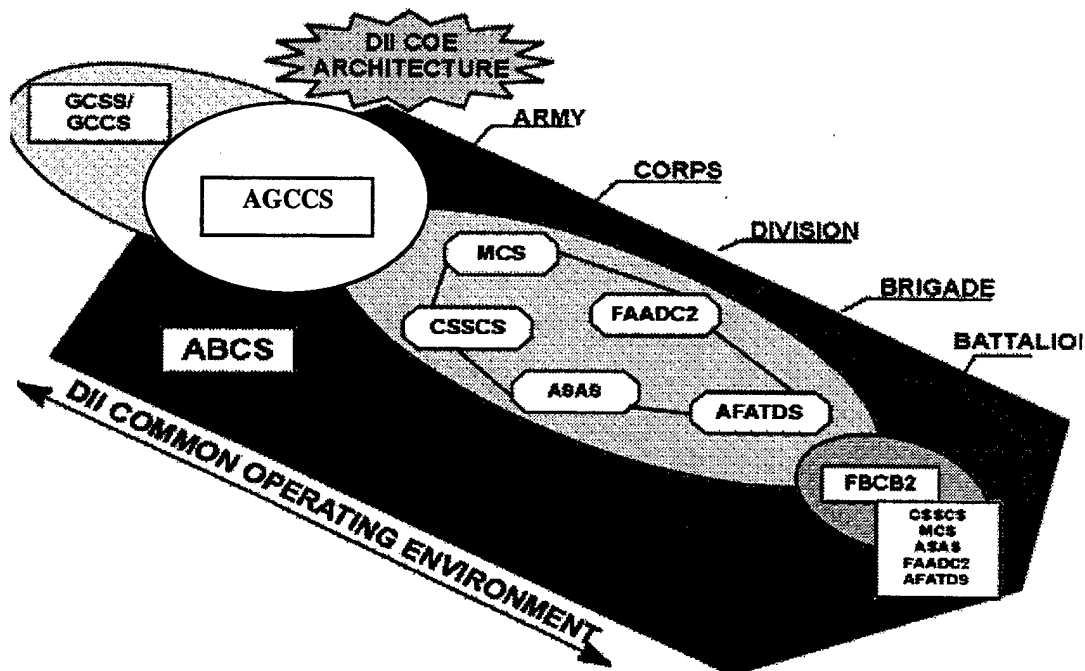

Figure 8 Army Battle Command System Relationship [Ref. 31]

The Army Battlefield Command System will have the capability to acquire, process, display and disseminate information, at all echelons, at varying levels of detail, to meet the requirements of mobile, dispersed commanders and staffs in the execution of their missions. ABCS will provide users with the ability to create, access and update a

FLI database and generate a user defined relevant, common picture of the battlefield in both time and space. Data contained in the FLI database will be derived compliant with DII COE, thereby ensuring interoperability with GCCS . In effect, the functional difference between workstations will be determined by the set of functional applications loaded on the machine.

The current developmental program of ABCS extend from the Joint/Strategic C4I systems via the Army Global Command and Control System (AGCCS), described in Chapter IV, through the theater of operations, to the operational/tactical headquarters, and culminates in near real-time, digital links among the tactical battlefield operating systems functions at brigade and below. [Ref. 3]

ABCS is made up of multiple C2 systems that operate from the strategic through tactical level. There are three components within ABCS - AGCCS, ATCCS and FBCB2 C2 system for echelons brigade and below. The ABCS is tied to the joint environment through GCCS. Each of the elements of the ABCS is further broken down into subordinate systems. Figure 9 depicts all of these systems and their inter-relationships.

ABCS satisfies two critical C2 requirements: situational awareness - what has come to be known as “the common picture” and interoperability. The common picture refers to a predefined representation of battlefield information that is contained in the FLI database. When this information is appropriately tailored in content and detail, it can provide a commander a current view of the battlespace. The common picture in ABCS may cross horizontal, vertical and functional boundaries. It is made up of three components:

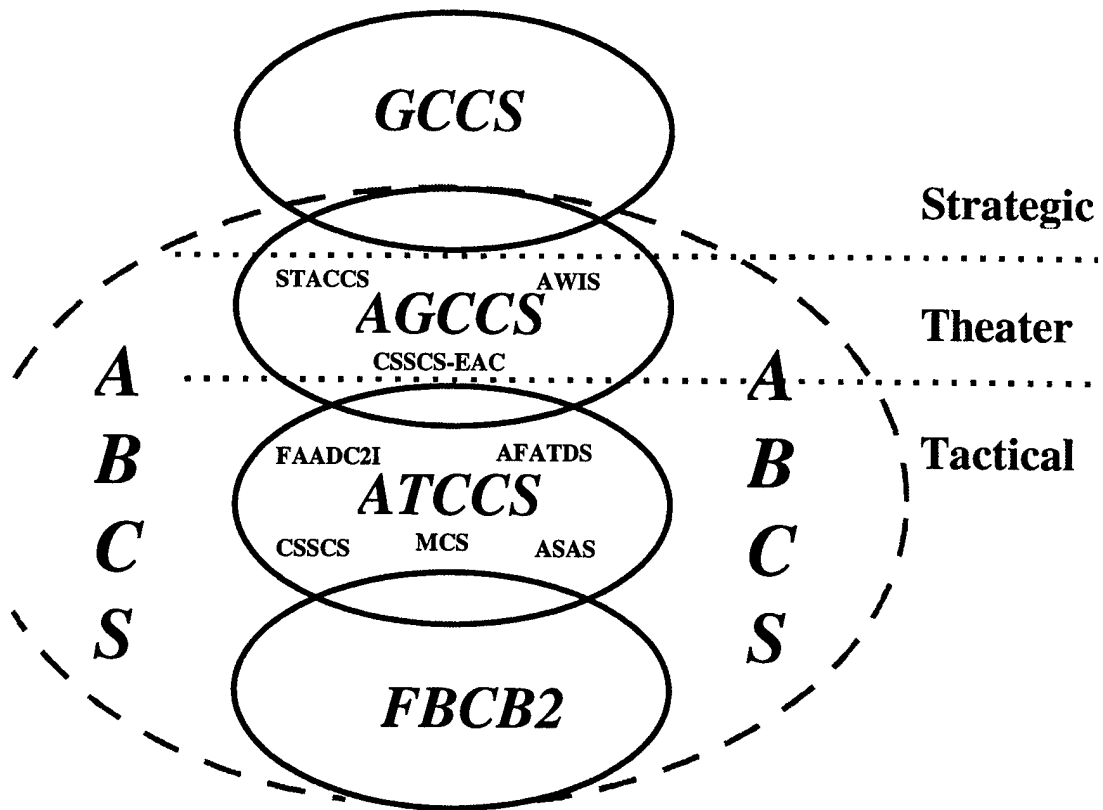

Figure 9 Army Battle Command System Hierarchy [Ref. 9]

- situation maps and overlays (the current friendly and enemy tactical situations, the projected enemy situation, and enemy resources)

- friendly battlefield resource reports
- intelligence products

ABCS has four fundamental components as shown in Figure 10:

- common hardware and operating system software
- unique and common user applications
- standard Army communications

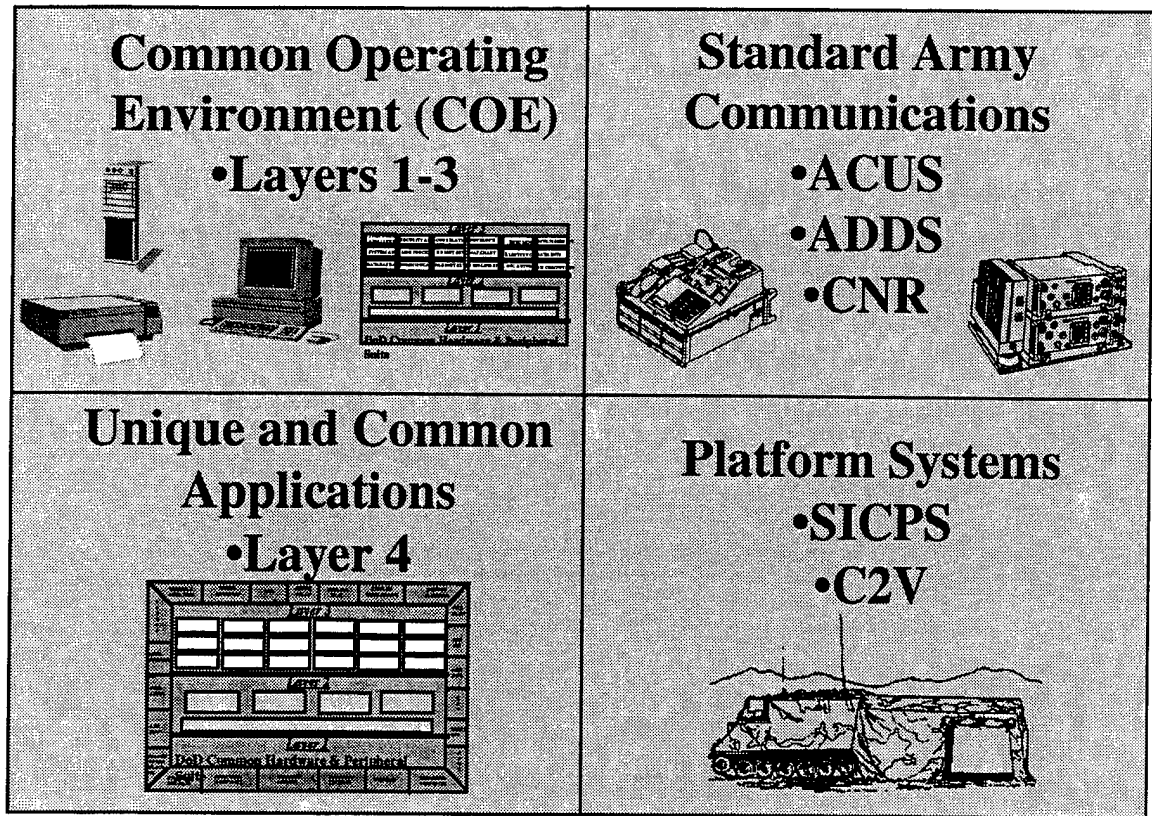

Figure 10 Army Battle Command System Components[Ref. 31]

- platform systems (i.e., Command and Control Vehicle (C2V) and the Standard Integrated Command Post System (SICPS)). [Ref. 9]

The Army Battlefield Command System is a continuously evolving network of C4I systems. With each new generation of applications and supporting communication and support software modules, the ABCS will be upgraded and undergo revalidation and limited testing to ensure full interoperability is maintained between applications, and operational facilities. [Ref. 3]

Finally, the system will have the ability to push and pull the following types of information into GCCS from ATCCS (described in Chapter II) through AGCCS (described in Chapter IV):

- Maneuver Control System (MCS) (described in Chapter III): Interfaces shall provide a capability to exchange common picture data.

- All Source Analysis System (ASAS) (described in Chapter III): Interfaces shall provide a capability to exchange intelligence data with the Enemy Situation database.

- Forward Area Air Defense Command Control and Intelligence System (FAAD C2) (described in Chapter III): Interfaces shall provide the capability to exchange Friendly/Enemy air track data.

- Combat Service Support Control System (CSSCS): Interfaces shall provide the capability to exchange Combat Service Support data.

- Advanced Field Artillery Tactical Data System (AFATDS): Interfaces shall provide the capability to exchange data pertaining to a call for fire and fire planning data.

The objective system shall provide 100% data exchange between FBCB2 (described in Chapter IV) and all of the ATCCS components. [Ref. 25]

C. DEFENSE ADVANCE RESEARCH PROJECT AGENCY

(DARPA)

DARPA is chartered to develop new technologies for the military. These new technologies are to be used to aid each service in achieving Joint Vision 2010. One of the projects currently being developed is the Battlefield Awareness and Data Dissemination (BADD) Advanced Concept Technology Demonstration (ACTD).

1. Battlefield Awareness and Data Dissemination

The Battlefield Awareness and Data Dissemination (BADD) Advanced Concept Technology Demonstration develops, installs and evaluates an operational system that allows commanders to design their own information system; delivers to warfighters an accurate, timely and consistent picture of the battlefield; and provides access to key transmission mechanisms and worldwide data repositories. To achieve this goal, the BADD system will:

- provide smart push and warrior pull via an Information Dissemination Server (IDS) accessing multiple data sources to include national and theater intelligence, operational and logistics information;
- use the data accessed to create a graphical depiction of the current situation which is consistent across services and up and down echelon within each service and which is linked to a variety of supporting information;
- allow the user to tailor the view of the battlespace by drilling down through the supporting information infrastructure to display and manipulate the underlying data using a BADD-provided tool kit compatible with the GCCS COE.

To achieve BADD's objectives, three system segments, each based on existing products and prototypes, will be integrated: the communications management service, a wideband, low-cost broadcast mechanism; the information management service, a means for the warfighter to request specific information from the field using existing communications; and the battlefield awareness service. Data accessed are from a wide range of information sources including UAV and national imagery, GCCS operational data, and fusion and exploitation sources, such as from the ASAS (described in Chapter

II), the JMCIS (described in Chapter II), the Air Force Combat Intelligence System (CIS), and the Common Ground Station (CGS). The battlefield awareness service will interface with existing tactical workstations and have the necessary software and hardware, where needed, to filter and store broadcast data and then present it as a coherent picture of enemy and friendly forces integrated with terrain, imagery and video data. Dissemination throughout the battlefield will be accomplished inexpensively using a Global Broadcast System (GBS) derived from commercial direct digital broadcast satellite technology. A Joint Tactical Internet will be created by integrating standard commercial network protocols and services on top of existing tactical communications systems. Warfighters will be able to request needed information using the Joint Tactical Internet and then receive it via direct broadcast. Figure 11 shows the communication interconnectivity for BADD. [Ref. 32]

The BADD IDS will access national information repositories and disseminate the information including imagery, data, and video based on warrior specified needs and the commanders information dissemination policy. The IDS broadcasts the data via GBS to all user sites. Warfighter Associates (WFA's) (a display for the COP) located at each site receive the GBS data, provide the warfighter the applications to view the COP and provide the interface to extent systems - ASAS, JMCIS, and MCS (all described in Chapter II), via tactical communications. The warfighters use the WFA or extent system through the WFA to inject or request operational data through their reachback capability,

The Vision: Data Dissemination

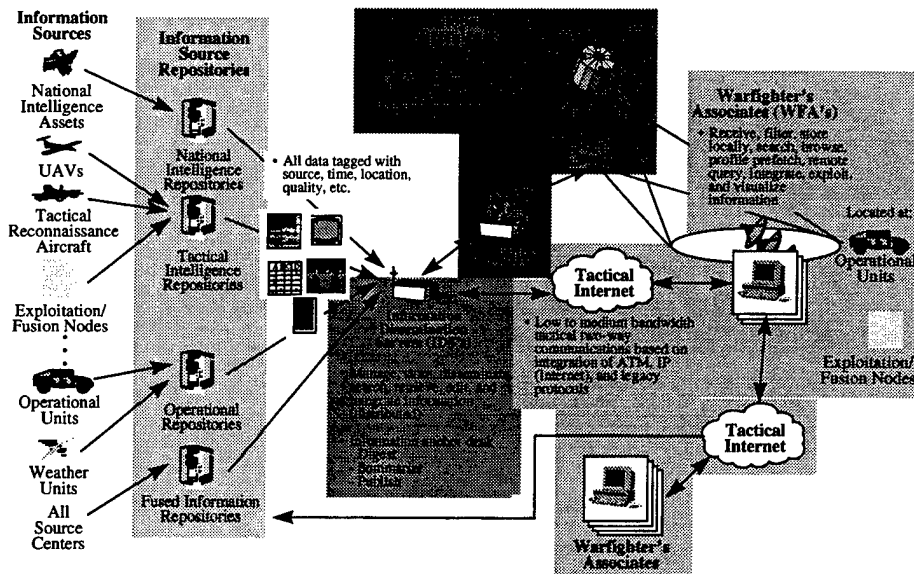

Figure 11 Battlefield Awareness and Data Dissemination Connectivity [Ref. 32]

providing a near-real time COP, as shown in Figure 12. Both the IDS and the WFA are DII COE based. [Ref. 32]

D. JOINT

When Vice Admiral Cebrowski was the Director for C4 Systems, J6, on the Joint Staff, a study was performed for future operational C2 system capabilities and enabling technologies. This study, performed by J6 and the Director of Defense Research and Engineering for the Office of the Secretary of Defense (OSD), was to be a roadmap to the C2 of the future. The findings were published in the following Advanced Battlespace Information System (ABIS) vision. [Ref. 33]

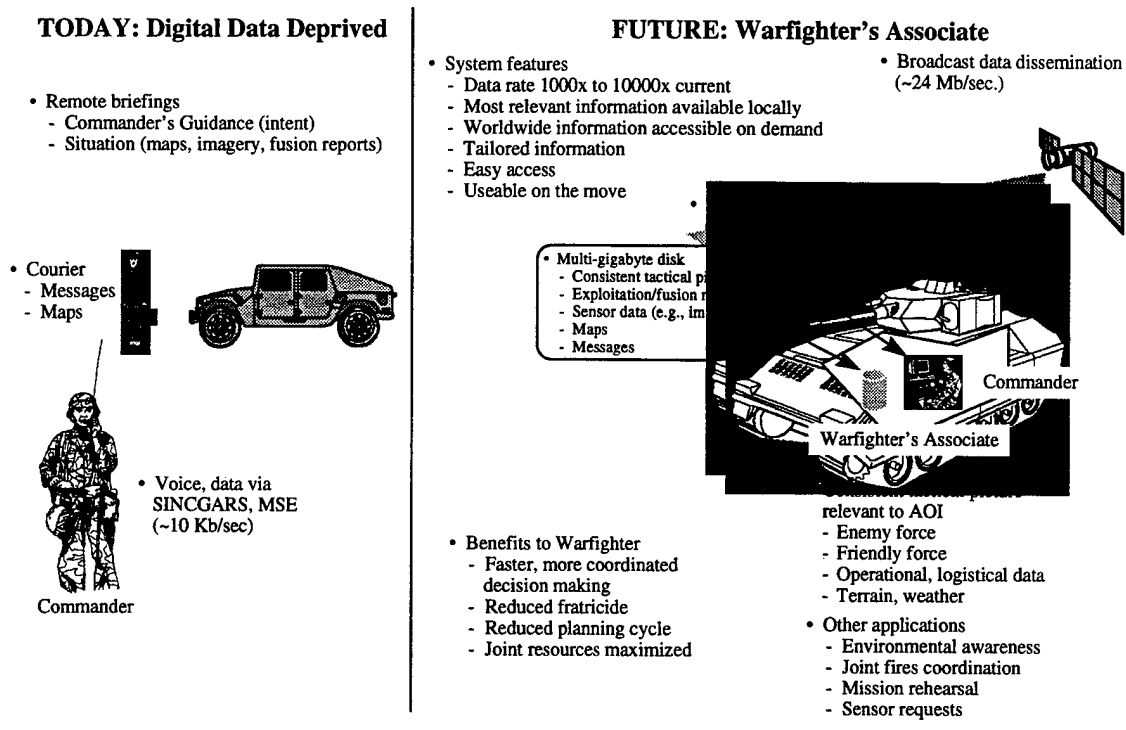

Figure 12 Battlefield Awareness and Data Dissemination Warfighter's Assistant [Ref. 32]

1. Advanced Battlespace Information System

The Advances Battlespace Information Systems (ABIS) study gave the Joint Staff and OSD a vision to achieve the Joint Vision 2010, published by the CJCS. ABIS will give warfighters a knowledge-based system environment that facilitates revolutionary operational capabilities. It is an evolving federated system-of-systems construct that give the following:

- enables warfighters everywhere to acquire and use knowledge
- allows employment of forces, weapons and sensors in a revolutionary manner

- helps sustain US military supremacy across the spectrum of conflict in the 21st Century.

The study identified a set of operational capabilities that ABIS must provide to meet the spectrum of challenges facing the United States. This set of capabilities forms a framework that can be portrayed as three supporting and supported layers: effective force employment, battlespace awareness and a grid of common information services. Figure 13 shows the three layers. Those layers on top of others layers depend on lower layers for certain services and for inputs. For this thesis, I will only describe the second layer, battlespace awareness. [Ref. 33]

ABIS Capability Framework

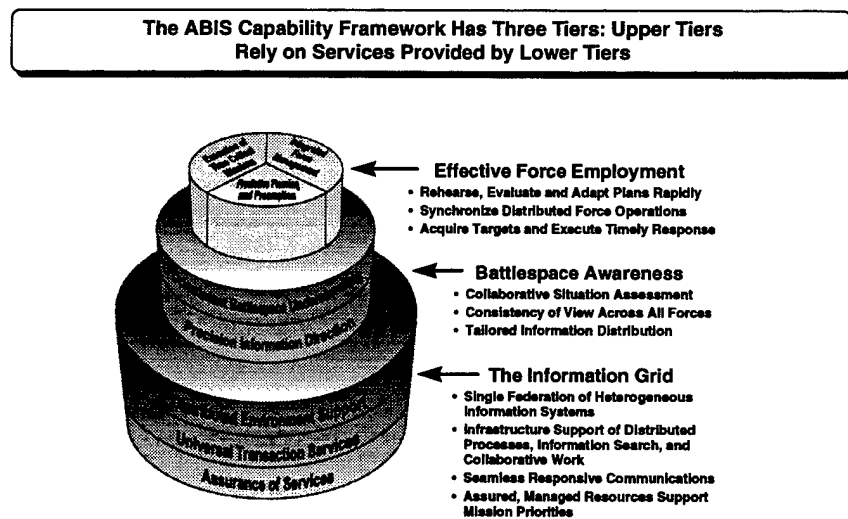

Figure 13 Advanced Battlespace Information System Layers [Ref. 33]

The second tier of the framework is a battlespace awareness capability, which is composed of precision information direction and consistent battlespace understanding.

Precision information direction involves the ability to collect, process and channel information to users in a timely and precise manner. It implies the ability of any warfighter to tailor the environment to support the mission needs by directing where different kinds of information can flow, when it flows and in what form it appears. Information collection, processing and dissemination must be dynamically focused on achieving the warfighter's specific mission objectives. Battlespace understanding involves consistent and collaborative assessment of an operational situation and objectives, including assessment of relevant support aspects. Assessors will typically be distributed across multiple locations and will not need the raw information, but will need information in the form conducive to the task at hand.

To achieve the battlespace awareness, the commander must have consistent battlespace understanding. Consistent battlespace understanding includes all functions involving the collection of relevant data and intelligence, the fusion of that information, the incorporation of that information into a consistent, layered situation representation and the cognitive presentation of that representation in a way that can be accessed and assimilated by all warfighters at all levels. The principal elements of the future consistent battlespace understanding concept are as follows:

- automated gathering of all relevant information from global databases, national and theater sensor systems and friendly plans, force readiness and status
- merging this information into a consistent, layered representation for situation assessment

- a cognitive, interactive presentation with varying degrees of aggregation, for access and assimilation by warfighters but customized by them for the information that they need.

This concept can also be viewed from the perspective that the warfighter is provided rapid access to all the information that exists relevant to the needs, uninhibited by the information systems itself. [Ref. 33]

E. MARINE CORPS

The Marine Corps is looking into combining two current systems into one system to provide a common picture down beyond the battalion level. While the two systems are currently fielded, the combination of the two is something that could inject information into the GCCS COP.

1. Command and Control Personal Computer

The Command and Control Personal Computer (C2PC) is a version of the Navy's JMCIS. It operates on commercial-off-the-shelf hardware. The application displays the last reported position of friendly and reported enemy locations transmitted from a JMCIS or GCCS terminal. The Marines are looking to combine this system with the Position Location Reporting System (PLRS), described in Chapter III. The combination of the two systems will provide a solution for projecting a common picture below the battalion level. With the two system integrated, the C2PC will maintain an internal database of PLRS and military identifications for each unit tracked to aid in correlation. [Ref. 34]

The combination will allow the extension of situational awareness below the battalion level by integrating the robust PLRS network with numerous distributed PCs

The combination will allow the extension of situational awareness below the battalion level by integrating the robust PLRS network with numerous distributed PCs throughout the battlefield. These PCs would receive positioning updates directly from a co-located basic user unit, and plot them as unit tracks directly within C2PC. With a wireless single channel radio TCP/IP connection between the C2PC and the Tactical Combat Operations (TCO) system, described in Chapter IV, the new system could provide a robust means of injecting position location information (PLI) data into JMCIS. Wireless TCP/IP also offers a way to pass overlays and other non-PLI unit tracks from higher headquarters for simultaneous display on a PLRS-aware C2PC application. Figure 14 shows the C2PC connection. PLI data is thus injected in a bottom-up fashion from subordinate units directly into the C2PC application as well as injected in a top-down fashion from JMCIS. This will enable C2PC to become the command and control application of choice for projecting a common picture to the small unit leader below the battalion level. [Ref. 35]

F. NAVY

The Navy is taking an evolutionary approach to development of future systems. It is updating JMCIS, described in Chapter II, from the UNIX based system to that of a Microsoft Windows NT based system. The new JMCIS has been named both JMCIS 98 as well as GCCS-M, the Global Command and Control System - Maritime.

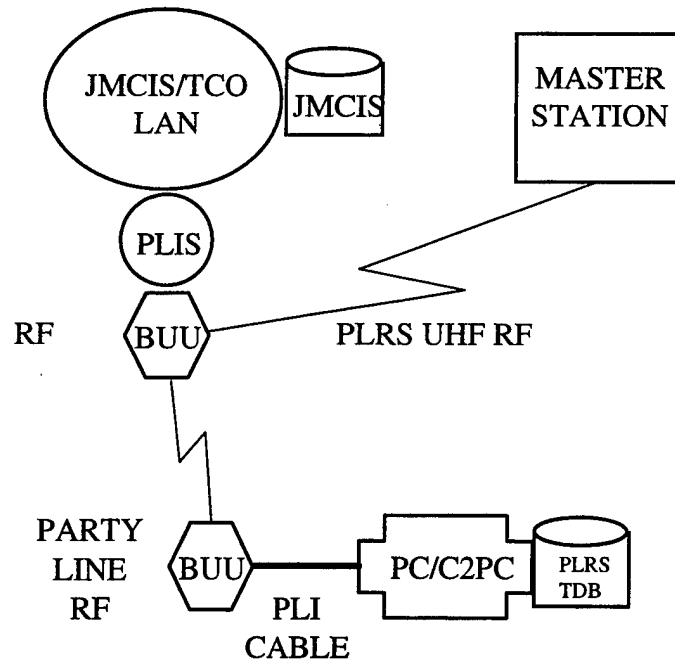

Figure 14 Command and Control Personal Computer Connectivity [Ref. 34]

VI CONCLUSIONS AND RECOMMENDATIONS

The previous chapters discussed the need for a common operational picture at all levels of command and the existing, planned and future efforts by each service and DoD agencies to support the requirement. It also examines a Joint Staff study on future requirements for commanders to have a common operational picture. This chapter presents conclusions and gives recommendations to improve the common operational picture.

A. CONCLUSION

This thesis gives a comprehensive review of the current situational awareness systems available to commanders in addition to current and future efforts to bring a common operational picture to all levels of command. With the decreasing budget, corresponding push for the services to save money due to the decreasing budget and the DoD's current focus on joint warfare, a system developed from the GCCS COP for lower levels of command would be logical. However, each service is either developing new systems or revising current systems for use at lower levels. These systems are DII COE compliant, but they are not interoperable beyond that. The services are still developing stovepipe systems, but they are now DII COE compliant.

The databases that is being used by each service at every different level of command is not centralized as it should be. Each service continues to use their own display system and obtain / input track information into their own database. In some cases, each level of command even maintains its own database. It is not until the CINC level that the databases are combined. This database is not sent down to the lower levels,

unless a direct communication link is established. It is however sent up to the national level.

Admiral Cebrowski, the former Director of C4 Systems (J6) on the Joint Staff, has stated that he made a tactical error concerning interoperability. He was under the impression that each service would move toward joint systems rather than stovepipe ones that are DII COE compliant. The services are ensuring that the systems are DII COE compliant, but no one is ensuring that the systems are compatible. The systems discussed in Chapters IV and V, Current and Future Efforts, state they are compatible with other services, but the truth is in reality, they are just DII COE compatible. The systems are interoperable only due to this degree of compatibility. [Ref. 36]

B. RECOMMENDATIONS

Each service is charged with training and equipping its forces. This is one of the driving factors in the multitude of operational picture systems across the services today. DISA developed GCCS as a national level system to replace WWMCCS. But, neither DISA nor any other agency has the charter to develop a single system for the services or to enforce the use of GCCS as a starting point in development of a service's common operational picture.

I recommend that DISA be given the authority to force the services to develop systems using GCCS DII COE as the basis for future COP systems. DISA is currently only empowered to oversee that each new or modified system complies with the DII COE. While this is important, it does not go far enough. Because the systems are only required to be GCCS DII COE compliant but not interoperable, translators between

systems will be required for integrated interoperability between services at the operational level.

The Joint Requirements Oversight Council (JROC) is charged with ensuring that there is not duplication of effort, but one can see from Chapters IV and V that duplication exists. Many systems are being developed that accomplish the same function, bringing a common but parochial operational picture to lower levels of command by service branch.

A Service Joint Program Office (JPO) for a common operational picture would solve the problem of duplicate and redundant systems and I recommend that one be established. But the services are hesitant to give authority to such an office. While I am not advocating a "purple" (joint) C4I organization, the services need to cooperate and develop basic core systems that each service will use, then develop service specific applications (such as displays) from that core. This may sound like the DII COE, but it is much more. It is similar to the Unified Build of JMCIS with each service having different ways to display the same information. The efforts to bring a common picture are commendable, but they need to be coordinated among the services, much like the coordination between the Navy and Marine Corps.

The primary issue that must be overcome is the one of a centralized architecture for the data contained within the database of each common operational picture. Each different level of command still maintains its own distinct database as does each service and CINC. While this should continue, the data contained within each database should be accessible from all levels of command, both horizontally and vertically. The data should be offered in a read only manner so each command's database is not corrupted. An architecture needs to be established that ensures connectivity and interoperability between

vertical and horizontal commands. Until this database architecture is established and maintained, commanders will not be able to get a true COMMON Operational Picture among all services at all levels of command.

LIST OF REFERENCES

1. Joint Staff J6, C4I for the Warrior, C4 Architecture and Integration Division (J6I), Pentagon, Washington, D.C., June 12 1993.
2. Department of the Navy, Copernicus ... Forward.
3. Department of the Army, Capstone Requirements Document (CRD) For the Army Battle Command System (ABCS), <http://leav-www.army.mil/tpioabcs/CRDA.htm>, September 30, 1997.
4. Department of the Air Force, Air Combat Command Concept of Operations for Theater Battle Management Core Systems, September 30, 1996.
5. Headquarters, U.S. Air Force, "JFACC Situational Awareness System information pamphlet," Received at Pentagon during October 1996 tour.
6. f. Office of the Assistant Secretary of Defense of C3I, Communications Handbook for Intelligence Planners, INCA Project Office, March 1, 1991.
7. C4I Integration Support Activity, C4I Handbook for Integrated Planning (CHIP), Defense Investigative Agency Publications, Washington, D.C., May 1996.
8. United States General Accounting Office, Battlefield Automation, Army Tactical Command and Control System's Cost and Schedule, Washington, D.C. February, 1990.
9. Baribeau, Stephen R., Colonel, U.S. Army, Information Paper, The Army Battle Command System (ABCS), July 30, 1996.
10. NRAD, "Command, Control, Communications, and Intelligence: System of Systems," Information pamphlet, Command and Intelligence Systems Division, San Diego, CA, 1993.
11. Bell, Carl H. III, Lieutenant Colonel, USAR, Theater Army Command and Control System: An Evaluation of the Requirement and Proposed Solution, Study project, U.S. Army War College, Carlisle Barracks, PA, May 1992.
12. Department of the Army, Maneuver Control System, Fact Sheet, Program Executive Office, Command and Control Systems, Fort Monmouth, New Jersey, 1994.
13. Department of the Army, STACCS, <http://www.stccs-home.army.mil/wsdocs/stccs/staccs/staccs.htm>, September 30, 1997.

14. Joint Staff J6, Joint Command, Control, Communications, and Computers Systems Description Volume II, Washington, D.C., 1994.
15. International Research Institute, Joint Maritime Command Information System (JMCIS) Common Operating Environment (COE), Restion, VA, October 1, 1993.
16. Joint Staff J3, Chairman Joint Chief of Staff Instruction 3151.01, Global Command and Control System Common Operational Picture Reporting Requirements, April 1, 1997.
17. Joint Staff J6V, "Global Command and Control System," Washington, D.C., Received at DISA tour October 96.
18. Air Force GCCS System Program Office, Air Force Global Command and Control System (GCCS) Migration Plan Guidance, August 8, 1996.
19. Joint Staff, Global Command and Control System User Concept of Operations, Washington, D.C., December 1, 1995
20. Defense Information Systems Agency Instruction, COTS Inclusion in the DII COE, April 1, 1997.
21. United States Central Command, Concept of Operations for Global Command and Control System Common Operational Picture, October 22, 1996.
22. Hughes Corporation, "Enhanced Position Location Reporting System (EPLRS)," Information sheet, May 1994.
23. Boyd, Autin, Commander, USN, "Rapid Response Through Space Reducing Battlefield Fratricide," Surface Warfare Magazine, September/October, 1996.
24. Office of the Assistant Secretary of Defense for C3I, Communications Handbook for Intelligence Planners, 3rd Edition, INCA Project Office, 1994.
25. Department of the Army, Operational Requirements Document for Force XXI Battle Command - Bridage and Below (FBCB2) Version 5, May 30, 1997.
26. Army Digitization Office, Experimental Master Plan Force XXI Battle Command - Brigade and Below Applique, October 19, 1995.
27. Flynn, Bill, Lieutenant Commander, USN, "JMCIS Update, Empowering the Warfighter," Surface Warfare Magazine, September/October 1995.

28. Kincaid, Gregory R., Captain, USAF, and Poligala, Richard A., Captain, USAF, An Independent Evaluation of Information Systems Support of the Joint Forces Air Component commander Concept of Operations, Master's Thesis, Air Force Institute of Technology, Wright-Patterson, Ohio, February, 22, 1994.
29. Eyer, Kevin, Lieutenant Commander, USN, "FACT (Force TEWA)," Surface Warfare Magazine, July/August 1995.
30. Goeringer, Michael L., 1st Lieutenant, USAF, New World Vistas Global Awareness Virtual Testbed Point Paper, August 19, 1997.
31. Army TRADOC Program Integration Office Army Battle Command System, ABCS Briefing, July 30, 1997.
32. Defense Advanced Research Project Agency, Battlefield Awareness and Data Dissemination Information Sheet, September 1997.
33. Department of Defense, Joint Staff, J6, Task Force, Advanced Battlespace Information System (ABIS) Study.
34. Marine Corps Tactical Systems Support Activity, A PLRS AWARE C2PC, Projecting Situational Awareness Below the Battalion Level, January 22, 1997.
35. Cummiskey, James C., Major, USMC, Technical Report #2 on Position Location Information (PLI) and Small Unit Situational Awareness in Support of Kernal Blitz 96, January 21, 1997.
36. Interview with Vice Admiral Arthur K. Cebrowski, USN, December 9, 1996.
37. Defense Information System Agency Joint Interoperability and Engineering Organization, Department of Defense Military Standard 2525 Common Warfighting Symbology Implementation Concept, August 2, 1994.

INITIAL DISTRIBUTION LIST

1. Defense Technical Information Center..... 2
8725 John J. Kingman Rd., Ste 0944
Ft. Belvoir, VA 22060-6218
2. Dudley Knox Library..... 2
Naval Postgraduate School
411 Dyer Rd.
Monterey, CA 93943-5101
3. C4I Academic Group, Code CC..... 1
Naval Postgraduate School
Monterey, CA 93943-5000
4. Professor Gary R. Porter, Code CC/PO..... 2
Naval Postgraduate School
Monterey, CA 93943-5000
5. Professor William G. Kemple, Code CC/KE..... 1
Naval Postgraduate School
Monterey, CA 93943-5000
6. Lieutenant Richard S. Hager 3
430 North Harbor Drive
Atlanta, GA 30328
7. Mr. Jon Stovall 1
4651 River Court
Duluth, GA 30097