

**Weather Systems Processor (WSP)
Demonstration Validation (DEMVAL)
Plan (Phase I and Phase II)**

Radame' Martinez
Tai Lee
Cindy Adamskyj
Baxter Stretcher

November 1997

DOT/FAA/CT-TN97/22

Document is on file at the William J. Hughes Technical Center
Library, Atlantic City International Airport, NJ 08405



U.S. Department of Transportation
Federal Aviation Administration

William J. Hughes Technical Center
Atlantic City International Airport, NJ 08405

DTIC QUALITY INSPECTED 3

19980414 146

ite technical note techni

NOTICE

This document is disseminated under the sponsorship of the U.S. Department of Transportation in the interest of information exchange. The United States Government assumes no liability for the contents or use thereof.

The United States Government does not endorse products or manufacturers. Trade or manufacturers' names appear herein solely because they are considered essential to the objective of this report.

1. Report No. DOT/FAA/CT-TN97/22	2. Government Accession No.	3. Recipient's Catalog No.	
4. Title and Subtitle Weather Systems Processor (WSP) Demonstration Validation (DEMVAl) Plan (Phase I and Phase II)		5. Report Date November 1997	6. Performing Organization Code
7. Author(s) Radamé Martínez, Tai Lee, Cindy Adamskyj and Baxter Stretcher, ACT-320; William Diviney and Anastatia Merkel, Science Applications International Corporation (SAIC)		8. Performing Organization Report No. DOT/FAA/CT-TN97/22	
9. Performing Organization Name and Address U.S. Department of Transportation Federal Aviation Administration William J. Hughes Technical Center Atlantic City International Airport, NJ 08405		10. Work Unit No (TRAILS)	11. Contract or Grant No.
12. Sponsoring Agency Name and Address U.S. Department of Transportation Federal Aviation Administration Integrated Product Team for Surveillance, AND-400 Washington DC, 20591		13. Type of Report and Period Covered Technical Note	
15. Supplementary Notes		14. Sponsoring Agency Code	
<p>16. Abstract</p> <p>Research and development of the Weather Systems Processor (WSP) is being accomplished in an effort to satisfy one of the Federal Aviation Administration's (FAA) performance goals in the area of System Efficiency, which is to develop and demonstrate the capability of new systems to decrease the rate of delays due to weather by 10 percent by the year 2002.</p> <p>This plan addresses the Massachusetts Institute of Technology/Lincoln Laboratory (MIT/LL) Demonstration Validation (DEMVAl) of the test bed WSP at their Terminal Radar Development Facility (TRDF) in Albuquerque, New Mexico. This DEMVAL began in November 1995, and will continue through 1997.</p> <p>The purpose of this plan is to provide an overview of the MIT/LL DEMVAL to assist the FAA with its DEMVAL monitoring responsibilities, and with future WSP Test and Evaluation (T&E) activities, including Development Test and Evaluation (DT&E) and Production Acceptance Test and Evaluation (PAT&E) monitoring and System Test conduct.</p>			
17. Key Words Weather Systems Processor (WSP) Demonstration Validation (DEMVAl) Airport Surveillance Radar Model 9 (ASR-9)		18. Distribution Statement Document is on file at the William J. Hughes Technical Center Library, Atlantic City International Airport, NJ 08405	
19. Security Classif. (of this report) Unclassified	20. Security Classif. (of this page) Unclassified	21. No of pages 39	22. Price

TABLE OF CONTENTS

	Page
EXECUTIVE SUMMARY	v
1. INTRODUCTION	1
1.1 Background	1
1.2 Purpose of DEMVAL Plan	2
1.3 Scope of DEMVAL Plan	2
2. REFERENCE DOCUMENTS	2
3. SYSTEM DESCRIPTION	4
3.1 System Overview	4
3.2 Interfaces Overview	10
4. DEMVAL PROGRAM DESCRIPTION	10
4.1 Approach and Concept	10
4.2 DEMVAL Environment/Location	13
4.3 DEMVAL Test Equipment and Analysis Tools	13
4.4 DEMVAL Description	13
5. DEMVAL MANAGEMENT	14
5.1 DEMVAL Management Organization	14
5.2 Training	16
5.3 System Configuration Management	16
5.4 DEMVAL Entry Criteria	17
5.5 DEMVAL Execution	17
5.6 DEMVAL Exit Criteria	17
5.7 DEMVAL Reports	18
5.8 System/Operational Deficiency Reports	18
5.9 DEMVAL Schedule	18
5.10 Personnel Resource Requirements	18
5.11 Planning Considerations and Limitations	18
6. ACRONYMS AND ABBREVIATIONS	20

APPENDIXES

A - Verification Requirements Traceability Matrix (VRTM) - TRDF Performance
Parameters Per FAA Order 6310.19

B - TRDF Configuration Baseline Status

C - Flight Inspection Plan

LIST OF ILLUSTRATIONS

Figure	Page
3.1-1 Weather Systems Processor (WSP) System Block Diagram	6
3.1-2 TRDF Prototype WSP - Phase I DEMVAL	9

EXECUTIVE SUMMARY

Research and development of the Weather Systems Processor (WSP) is being accomplished in an effort to satisfy one of the Federal Aviation Administration's (FAA) performance goals in the area of System Efficiency, which is to develop and demonstrate the capability of new systems to decrease the rate of delays due to weather by 10 percent by 2002.

The WSP will be deployed at medium density airports to enhance the safety of air travel through the timely detection and reporting of hazardous wind shear in and near the terminal approach and departure zones of an airport. Timely detection of hazardous weather events will improve the management of air traffic in terminal areas, thereby increasing airport capacity.

The WSP will provide detection, processing, and communication of hazardous weather information (such as microbursts, and gust fronts) to controllers.

This plan addresses the Massachusetts Institute of Technology/Lincoln Laboratory (MIT/LL) Demonstration Validation (DEMVAL) of the test bed WSP at their Terminal Radar Development Facility (TRDF) in Albuquerque, New Mexico. This DEMVAL began in November 1995, and will continue through 1997.

The MIT/LL DEMVAL was divided into two phases. DEMVAL Phase I demonstrated that some critical subsystems of WSP (radio frequency (RF), radar timing, and digital signal interfaces) did not prevent recertification of the Airport Surveillance Radar-9 (ASR-9) search radar performance. DEMVAL Phase II, using a re-engineered enhanced prototype WSP, consists of an operational demonstration of simultaneous target channel, six-level Anomalous Propagation (AP)-corrected weather, and WSP functionality.

The contents and format of this WSP DEMVAL Plan comply with the guidelines and requirements defined in the FAA National Airspace System (NAS) Test and Evaluation Policy (FAA Order 1810.4B), and the FAA Preparation of Test and Evaluation Plans and Test Procedures Standard (FAA-STD-024B).

1. INTRODUCTION.

Research and development of the Weather Systems Processor (WSP) is being accomplished in an effort to satisfy one of the Federal Aviation Administration's (FAA) performance goals in the area of System Efficiency, which is to develop and demonstrate the capability of new systems to decrease the rate of delays due to weather by 10 percent by 2002.

The WSP will be deployed at medium density airports to enhance the safety of air travel through the timely detection and reporting of hazardous wind shear in and near the terminal approach and departure zones of an airport. Timely detection of hazardous weather events will improve the management of air traffic in terminal areas, thereby increasing airport capacity.

The WSP will provide detection, processing, and communication of hazardous weather information (such as microbursts, and gust fronts) to controllers.

This plan addresses the Massachusetts Institute of Technology/Lincoln Laboratory (MIT/LL) Demonstration Validation (DEMVAL) of the test bed WSP at their Terminal Radar Development Facility (TRDF) in Albuquerque, New Mexico. This DEMVAL began in November 1995, and will continue through 1997.

The contents and format of this WSP DEMVAL Plan comply with the guidelines and requirements defined in the FAA National Airspace Subsystem (NAS) Test and Evaluation Policy (FAA Order 1810.4B), and the FAA Preparation of Test and Evaluation Plans and Test Procedures Standard (FAA-STD-024B).

1.1 BACKGROUND.

The WSP DEMVAL is being conducted in accordance with the new FAA Acquisition Management System (AMS). Completion of the WSP DEMVAL will allow the project to progress to the solution implementation phase.

Since 1986, AND-420 has sponsored MIT/LL to evaluate the low-altitude wind shear detection capabilities (microburst and gust front) of the WSP, a relatively low-cost modification to the Airport Surveillance Radar-9 (ASR-9) which allows this detection without interfering with the primary function of the ASR (aircraft detection and tracking). Coverage will be provided to medium-sized airports not slated for a dedicated Terminal Doppler Weather Radar (TDWR).

To investigate algorithmic performance under diverse weather conditions, MIT/LL established and operated a WSP test bed in Huntsville, Alabama, from 1987 to 1988; in Kansas City, Missouri, in 1989; in Orlando, Florida, from 1990 to 1992; and in Albuquerque, New Mexico, since 1993. MIT/LL is currently refining the algorithms for operation in an environment known for frequent "dry" wind shear activity. At each test bed site, MIT/LL utilized one or more pencil-beam Doppler weather radars to provide meteorological "truth" to develop and validate the test bed's algorithms.

The MIT/LL DEMVAL is divided into two phases. DEMVAL Phase I, completed in January 1996, demonstrated that some critical subsystems of the WSP radio frequency (RF), radar timing, and digital signal interfaces) did not degrade ASR-9 search radar performance. DEMVAL Phase II, currently underway using an MIT/LL re-engineered enhanced prototype WSP, consists of an operational demonstration of simultaneous target channel, six-level Anomalous Propagation (AP)-corrected weather, and WSP functionality.

After a successful DEMVAL, the FAA will monitor and conduct System Test activities, including contractor Development Test and Evaluation (DT&E), contractor Production Acceptance Test and Evaluation (PAT&E), and System Test to verify that the WSP meets the requirements contained in the WSP Requirements Document and the WSP Test and Evaluation Master Plan (TEMP) Verification Requirements Traceability Matrix (VRTM).

1.2 PURPOSE OF DEMVAL PLAN.

The purpose of this plan is to provide an overview of the MIT/LL DEMVAL to assist the FAA with its DEMVAL monitoring responsibilities, and to assist the FAA with future WSP Test and Evaluation (T&E) activities, including DT&E and PAT&E monitoring and System Test conduct.

1.3 SCOPE OF DEMVAL PLAN.

The scope of this plan includes WSP system, DEMVAL program, and DEMVAL management descriptions. These descriptions include both system and interface overviews, DEMVAL objectives and approach, participating organizations' roles and responsibilities, schedules, and other planning considerations.

This plan also includes a DEMVAL VRTM comprised of ASR-9 Terminal Radar blue-sheet standards and tolerances, or system Minimum Acceptable Operational Requirements (MAOR). This VRTM is included as appendix A.

2. REFERENCE DOCUMENTS.

The following specifications, standards, publications, orders, and other miscellaneous documents were used in preparation of this document.

FAA DOCUMENTS

FAA Specifications

FAA-E-2917 Specification for the Weather Systems Processor

NCP 17112 Wind Shear System Deployment Requirement Changes NAS Change Proposal (NCP), April 14, 1995.

NCP 18718 ASR-9 Weather Systems Processor Demonstration at Albuquerque International Airport NCP, April 17, 1996.

FAA Standards

FAA-STD-024B Preparation of Test and Evaluation Plans and Test Procedures, August 22, 1994.

Other FAA Publications

AMS FAA Acquisition Management System, April 1, 1996.

FAA Order 1810.4B FAA NAS Test and Evaluation Policy, October 22, 1992.

FAA Order 6310.19 ASR-9 System Maintenance Book.

WSP Requirements Document Weather Systems Processor Requirements Document, October 15, 1996.

WSP TEMP WSP TEMP, June 5, 1997.

DOT/FAA/CT-TN92/48 Final Report for the Air Traffic Control (ATC) Evaluation of the Prototype ASR-WSP at Orlando International Airport, March 1993.

DOT/FAA/CT-TN94/4 Final Report for the Operational OT&E of the Prototype ASR-WSP at Albuquerque International Airport, March 1994.

WSP DEMVAL Phase I Report ACT-320 WSP DEMVAL Phase I Monitoring Report of TRDF Activities, February 12, 1996.

MISCELLANEOUS DOCUMENTS

MIT/LL DEMVAL Test Plan Test Plan for WSP to ASR-9 Interfaces, September 1, 1995.

MIT/LL DEMVAL Phase I Memo WSP Phase I Interface Testing at Albuquerque, November 28, 1995.

MIT/LL Project Report ATC-247 ASR-9 Weather Systems Processor (WSP) Wind Shear Algorithms Performance Assessment, April 19, 1996.

MIT/LL Project ASR-9 Weather System Processor (WSP) Signal Processing

Report ATC-255 Algorithms, July 24, 1996.

MIT/LL Memo No. Evaluation of the Effects of the Weather Systems Processor (WSP)
43PM-WX-0045 Hardware on ASR-9 Performance, August 30, 1996.

3. SYSTEM DESCRIPTION.

This section contains an overview of the MIT/LL test bed WSP located at the TRDF in Albuquerque, New Mexico.

3.1 SYSTEM OVERVIEW.

The WSP is a modular hardware and software modification to the ASR-9 primary radar. The system includes radar interfaces to provide necessary signals, an additional receiving chain, a modular signal processing computer, recorders (archive, base data, and time-series), and display terminals.

The production WSP will be composed of four functional areas as illustrated in figure 3.1-1, Weather Systems Processor (WSP) System Block Diagram: Radar Data Acquisition (RDA), Radar Data Processor (RDP), Remote Monitoring Function (RMF), and Display Function (DF).

The RDA consists of microwave and digital interfaces to the ASR-9, including a high-dynamic range receiver that provides in-phase and quadrature (I&Q) samples to the WSP data processor. The RDA acquires and digitizes microwave signals from the ASR-9, as well as timing, reference, and radar state data. The RDA performs certain control functions for waveguide switches, coaxial switches, and Sensitivity Time Control (STC)/Automatic Gain Control (AGC) attenuators within the WSP system and the ASR-9. In addition, the RDA controls the routing of RF signals to the WSP to acquire active channel high and low beam signals on an alternating scan basis.

The RDP is a Commercial Off-The-Shelf (COTS) data processor that performs data accumulation, clutter suppression, base data generation, product generation and data archiving using Government-supplied software. In addition, the RDP provides contractor-defined hardware and software to feed back WSP-generated six-level weather data to the ASR-9 system for display on radar controllers' displays.

The DF is hosted in COTS processors at the Air Traffic Control Tower (ATCT) and Terminal Radar Approach Control (TRACON) facility, remote from the ASR-9 radar site. The DF performs display, and control using Government-supplied software. The DF and RDP communicate via specified communication circuits.

WSP will contain a capability for system status monitoring, reporting, maintenance alert and alarm processing, and fault isolation. The RMF function is provided for automatic fault detection and location. The RMF is also the entry port for maintenance commands and control and for entering

site adaptable data. The RMF will provide maintenance related data and control functions to FAA maintenance specialists.

The primary mission of the WSP is the timely detection and reporting of hazardous wind shear phenomena in and near the approach and departure zones of an airport. The secondary mission is the detection of gust fronts or wind-shift lines that will subsequently impact airport operations. Additionally, the WSP will calculate and display storm motion vectors and AP-censored six-level precipitation (reflectivity). However, the six-level weather will not be integrated through the Surveillance Communications Interface Processor (SCIP) during DEMVAL, as it will be in the production WSP.

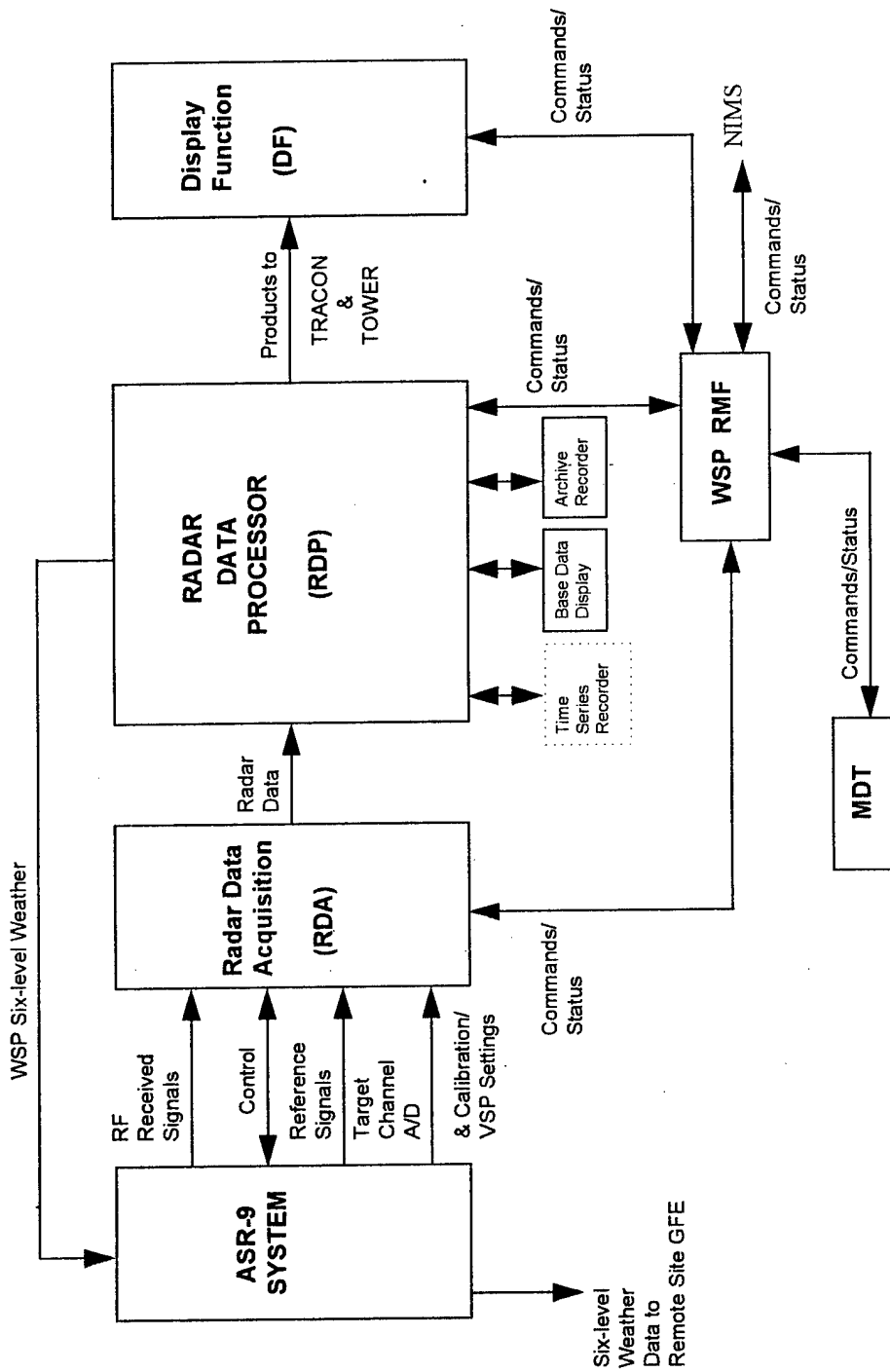

FIGURE 3.1-1. WEATHER SYSTEMS PROCESSOR (WSP) SYSTEM BLOCK DIAGRAM

Figure 3.1-2 contains a high-level block diagram of the TRDF WSP prototype used for DEMVAL Phase I. The TRDF WSP was comprised of:

- a. an ASR-9 host radar;
- b. interfaces to extract necessary RF and timing signals from the ASR-9;
- c. identical receivers and analog-to-digital (A/D) converters for the high and low beam receiving channels of the host radar;
- d. a VME-chassis high speed digital signal processor that suppresses interference (e.g., ground clutter) and computes base data (i.e., estimates of weather reflectivity, Doppler velocity, and spectrum width for each range-azimuth resolution cell);
- e. recorders to archive both the in-phase and quadrature (I&Q) and base data;
- f. single-board computers and workstations that run microburst, gust front detection, and storm motion algorithms, generate precipitation reflectivity maps, and transmit the resulting products to the ATCT;
- g. remote workstations and monitors that provide graphical and alphanumeric displays to air traffic controllers and their supervisors.

For DEMVAL Phase II, MIT/LL is using a system equivalent to the WSP system used in Phase I in that the Phase II system accomplishes identical tasks. Phase I used the existing TRDF WSP test bed, Phase II is using a re-engineered enhanced WSP prototype which will utilize additional hardware and software. Phase II equipment changes include the following:

- a. interface cards (for timing and digital signal interfacing between the ASR-9 and WSP and format the data records feeding the WSP high-speed signal processor) will be redesigned and refabricated,
- b. one receiving chain will be used. (Phase I DEMVAL used separate identical receivers and A/D converters; one receive channel collected high beam data returns, the other collected low beam data returns.) Phase II DEMVAL is using one receive channel to collect both high and low beam data returns in an alternate scan mode. The receiver and A/D converter, along with the data processing computers, is integrated into a single equipment rack,
- c. data is being collected in both circular polarization (CP) and linear polarization (LP) modes, on a time alternating basis. (Phase I DEMVAL collected base data in LP mode only.),
- d. all RF interfaces and appropriate control logic are implemented,

- e. data processing software to accommodate interface changes are modified,
- f. a display for monitoring system status and entering commands is set up in the radar shelter.

The DEMVAL Phase II WSP system supports simultaneous target channel, AP-corrected six-level weather display, and WSP functionality. As previously mentioned, AP-corrected six-level weather is not being integrated through the SCIP as it will be in the production unit.

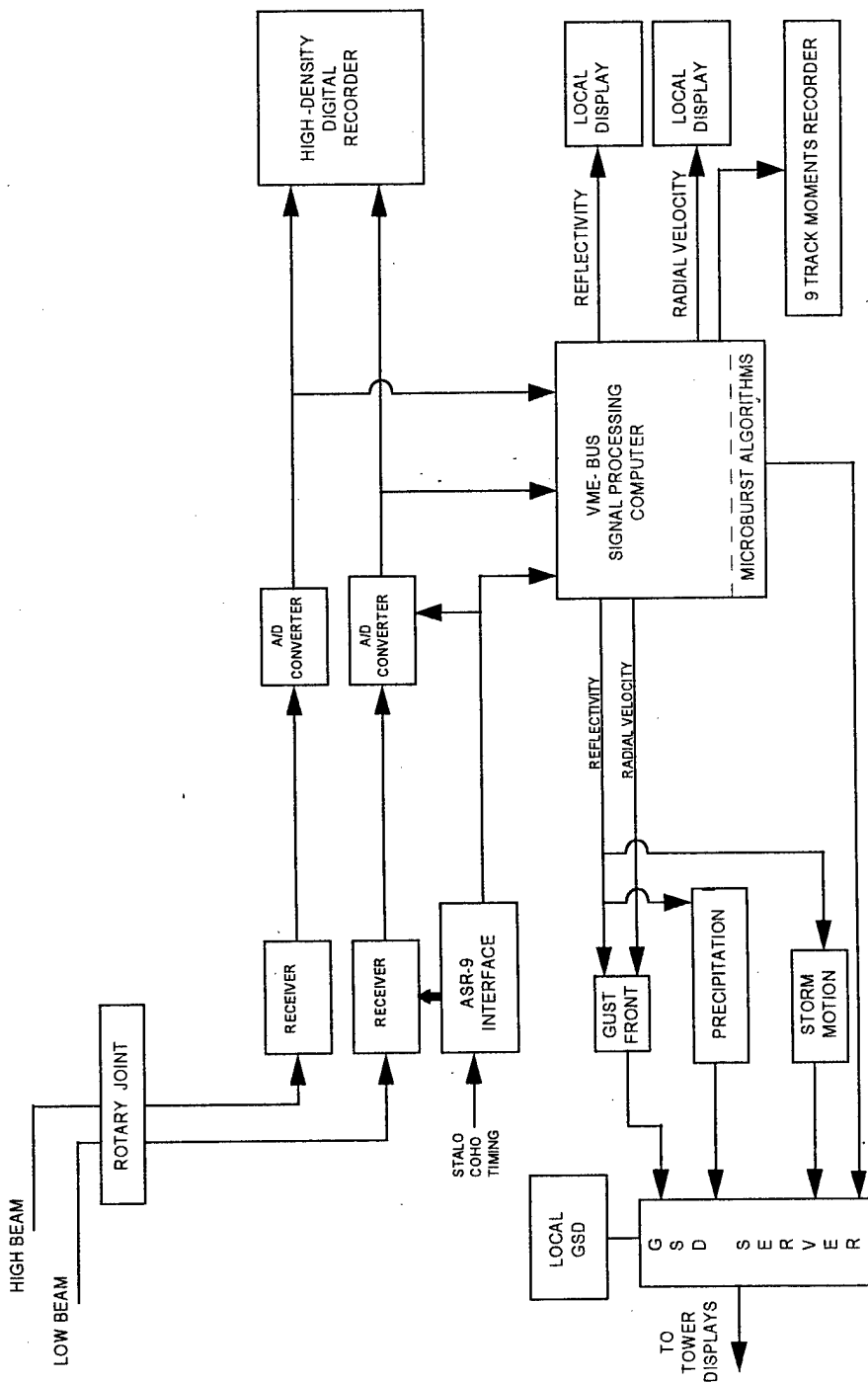

FIGURE 3.1-2. TRDF PROTOTYPE WSP - PHASE I DEMVAL

3.2 INTERFACES OVERVIEW.

The WSP directly interfaces with the ASR-9 system to receive primary radar RF timing and reference signals. These interfaces allow base data to be collected to generate weather products.

4. DEMVAL PROGRAM DESCRIPTION.

This section describes the overall DEMVAL program, including the DEMVAL approach and concept, Critical Operational Issues (COI), and MAORs.

4.1 APPROACH AND CONCEPT.

DEMVAL Phase I demonstrated that the WSP interfaces tested did not prevent ASR recertification. With support from FAA Airway Facilities (AF) personnel, MIT/LL conducted tests on both channels. Channel A was configured as a standard ASR-9 with the pertinent WSP RF modifications in place. Channel B was configured as a standard ASR-9. Tests on each channel included some optimization, a system configuration audit, and a run-through of applicable blue-sheet standards and tolerances from the ASR-9 System Maintenance Book. These "side-by-side" measurements were analyzed and compared to the ASR standards and tolerances. In addition, a flight inspection was conducted to further analyze the WSP impact on each channel's detection performance. The flight inspection plan is included as appendix C. Finally, a power and grounding survey was conducted at the TRDF to establish a baseline site survey to indicate if previously observed operational anomalies could be traced to possible facility problems.

DEMVAL Phase II demonstrates WSP functionality using MIT/LL's enhanced WSP prototype. Both Channels A and B are set up with the new prototype configuration. The TRDF then provides operational WSP products to Albuquerque Air Traffic (AT) personnel on a Geographic Situation Display (GSD) and Ribbon Display Terminals (RDT) through existing communication lines.

4.1.1 Evaluation Approach.

DEMVAL Phase I testing concentrated on some of the ASR to WSP interfaces, including some RF, digital, and timing signal interfaces. Phase I testing verified that the WSP did not produce operationally significant changes in the target channel's stability or sensitivity, the target channel's ability to track aircraft, or its required control and timing signals. Tests were performed on both channels and results were compared to the MAORs included in the VRTM.

DEMVAL Phase II testing consists of an operational validation of the WSP and its capability to provide useable weather data and weather surveillance functions without impacting ASR-9 search radar performance. Phase II testing uses an enhanced prototype WSP interfaced to the TRDF.

4.1.2 Critical Operational Issues.

Three WSP COIs are identified in the WSP Requirements Document and fully explained in the WSP TEMP. As explained below, parts of some of these COIs may be satisfied during DEMVAL testing, but because the DEMVAL WSP system is a prototype system, the COIs will also be re-evaluated and satisfied during limited production System Test as well. Refer to the ACT-320 WSP DEMVAL Phase I Monitoring Report for Phase I test results and prototype system limitations. The three WSP COIs and their relation to DEMVAL follow.

a. *Will the integration of the WSP with the host ASR prevent recertification of the ASR?*

Although the main objective of DEMVAL is to provide validation that the installation of a WSP onto a host ASR-9 does not cause significant degradation to ASR search capabilities, this COI cannot be fully addressed during DEMVAL. Although DEMVAL Phase I did demonstrate that some critical subsystems of the WSP (RF, radar timing, and digital signal interfaces) did not prevent recertification of the ASR, there are many differences between the MIT/LL prototype WSP and the limited production WSP systems. Some of these differences include the following: (1) the DEMVAL prototype does not include RMF capabilities; (2) there is no integrated six-level weather via the SCIP; (3) there is no Built-in-Test/Fault Isolation Test (BIT/FIT); and (4) there is no RF/Intermediate Frequency (IF) automatic calibrator. In addition, the prototype does not meet all FAA requirements for temperature, humidity, structure, etc., and the signal and control lines for the WSP are being tapped from existing circuits and do not have complete isolation.

This COI will be fully addressed during limited production System Test.

b. *Does the WSP system provide weather products that are sufficient for AT use?*

The objective of DEMVAL testing is primarily to provide validation that the critical subsystems of the WSP interface (RF, radar timing, digital signal interfaces) would not degrade ASR-9 target search capability. Some weather data will be collected and can be used to partially resolve this COI. However, due to the differences between the WSP prototype and limited production systems, this COI can only be fully addressed during System Test.

The reader is referred to the Final Report for the Operational OT&E of the Prototype ASR-WSP at Albuquerque International Airport, a March 1994 ACT-320 report highlighting findings from the 1993 summer air traffic evaluation.

c. *Will WSP products enhance the effectiveness of traffic planning/management (delays, airport acceptance rate, traffic flow, etc.) during adverse weather conditions in the terminal area? Are terminal airspace and runways used more effectively?*

This COI encompasses the purposes for which the WSP is required. The WSP will provide air traffic controllers and supervisors with timely and accurate information on hazardous wind shear, microbursts, storm location and movement, and future wind shifts that may affect airport runway usage.

This COI is partially resolved as a result of MIT/LL Project Report ATC-249, Assessment of the Delay Aversion Benefits of the Airport Surveillance Radar (ASR) Weather Systems Processor (WSP). Among other things, this report assesses the magnitude of the delay aversion benefits that will be realized through national deployment of WSP. These benefits are quantified both in terms of aircraft-hour reductions and corresponding benefits. The analysis indicates that these benefits will total \$18 million per year given 2,000 expected traffic counts at the planned WSP airports.

It should be noted that WSP prototype testing that occurred at ATC Facilities in Orlando (1990-1992) and Albuquerque (1993-1996) did not include interfaces necessary to feed six-level weather reflectivity maps free of AP contamination to controllers' Data Entry and Display Subsystem (DEDS) and Digital Bright Radar Indicator Tower Equipment (DBRITE) displays. Therefore, this capability of the WSP has not been evaluated by direct demonstration. Future System Testing will include evaluation of AP-corrected six-level weather as seen on both the DEDS and DBRITE displays.

The COI will not be fully addressed during DEMVAL due to DEMVAL time constraints, single-location testing, and the possibility of the lack of sufficient weather events.

4.1.3 Minimum Acceptable Operational Requirements (MAOR).

The ASR MAORs are comprised of many of the ASR-9 Maintenance Book blue-sheet standards and tolerances, the ASR baseline configuration Electronic Equipment Modifications (EEM), and the DEMVAL flight inspection results. Appendix A includes a VRTM made up of the standards and tolerances, listed as performance parameters. Appendix B lists the baseline configuration EEMs. Appendix C includes the flight inspection plan used for Phase I testing.

4.1.4 Activities Leading to DEMVAL.

Prior to the start of DEMVAL testing, the following activities must be completed:

- a. necessary test equipment and analysis tools must be on-site and available,
- b. predemonstration Test Readiness Review (TRR) between participating organizations to ensure that the demonstration is ready to commence and that all participants have an understanding of the demonstration requirements and events,
- c. coordination with pilot and local air traffic for flight inspections (Phase I only),
- d. the TRDF must be properly configured with the latest FAA-approved and released EEMs (Phase II only),
- e. the enhanced prototype WSP must be constructed and properly configured (Phase II only),

- f. all interfaces (input and output) and communications lines installed (Phase II only),
- g. final baseline configuration must be provided to the FAA.

The aforementioned FAA-released ASR-9 EEMs are listed in the configuration baseline status included as appendix B.

4.2 DEMVAL ENVIRONMENT/LOCATION.

DEMVAL Phase I and Phase II are taking place at MIT/LL's TRDF in Albuquerque, New Mexico.

4.3 DEMVAL TEST EQUIPMENT AND ANALYSIS TOOLS.

External test equipment shall include, but not be limited to, alternating current (ac) power measuring equipment, attenuators, power meters, and an aircraft for the flight inspection. In addition, MIT/LL used the XRAP and WRITEASR data recording utilities during the flight inspection (Phase I only).

4.4 DEMVAL DESCRIPTION.

This section describes objectives, criteria, and approach for both DEMVAL Phase I and Phase II.

4.4.1 DEMVAL Objective.

The objective of DEMVAL Phase I was to confirm that the WSP's connected interfaces did not degrade the ASR-9 target channel's transmit/receive chain stability, sensitivity, noise figure, or its ability to track aircraft. (Refer to the ACT-320 WSP DEMVAL Phase I Monitoring Report for Phase I test results.) The objective of DEMVAL Phase II is to conduct an operational demonstration of simultaneous target channel, AP-corrected six-level weather, and WSP functionality.

4.4.2 DEMVAL Approach.

4.4.2.1 DEMVAL Phase I Approach.

MIT/LL configured the TRDF such that Channel A was as a standard ASR-9 with some WSP functionality installed and Channel B was as a standard ASR-9. Tests on each channel included some system optimization, a system configuration audit, and a run-through of applicable blue-sheet standards and tolerances from the ASR-9 Maintenance Handbook. Test results and measurements from both channels were compared to MAORs. In addition, a flight inspection was conducted to further analyze the WSP impact on each channel's detection performance. MIT/LL and FAA Southwest region personnel conducted these tests. Finally, a power and grounding survey was conducted at the TRDF to establish a baseline site survey to indicate if previously

observed operational anomalies could be traced to possible facility problems. ACT-330 conducted this survey. ACT-320 witnessed all Phase I tests.

4.4.2.2 DEMVAL Phase II Approach.

This testing, that is divided in two stages, provides operational validation that the re-engineered prototype WSP can provide required weather surveillance functions and useable weather data without impacting ASR-9 search radar performance.

The first stage is a repeat of most of the tests conducted during Phase I: system certification checks and necessary optimization, a system configuration audit, and a run-through of applicable blue-sheet standards and tolerances from the ASR-9 Maintenance Handbook for both channels. The second stage is being accomplished using the TRDF to provide operational WSP products to Albuquerque AT personnel through existing communications lines.

4.4.3 DEMVAL Execution Time.

DEMVAL Phase I testing was conducted from November 1995 to January 1996. MIT/LL prepared and submitted a report (February 1996) to AND-420.

DEMVAL Phase II testing is currently underway and will continue through 1997.

5. DEMVAL MANAGEMENT.

This section lists the organizations associated with the WSP DEMVAL and describes each organization's roles and responsibilities in accordance with FAA Order 1810.4B.

5.1 DEMVAL MANAGEMENT ORGANIZATION.

The principle organizations which will participate in the WSP DEMVAL include AND-420, ACT-320, AOS-250, AOS-270 (formerly AOS-520), ACT-421 (Phase I only), FAA Southwest Region (Phase I only), Albuquerque (ABQ) Air Traffic, and MIT/LL.

5.1.1 Roles and Responsibilities.

The specific roles and responsibilities of participating organizations are listed below.

<u>Organization</u>	<u>Primary Role/Function</u>
AND-420	Direct, fund, and manage all demonstration efforts. Prepare and approve Program Directives (PD), NCPs, and other appropriate agreements delineating organizational activities, resources, and funding. Participate in biweekly telephone conference to discuss test status, problem resolution, etc. Approve this WSP DEMVAL Plan.
ACT-320	Monitor DEMVAL activities and provide coordination between participating organizations. Conduct biweekly telephone conference to discuss test status, problem resolution, etc. Prepare reports to highlight DEMVAL results.
AOS-250	Monitor DEMVAL activities. Participate in biweekly telephone conference to discuss test status, problem resolution, etc.
AOS-270	Monitor DEMVAL activities. Participate in biweekly telephone conference to discuss test status, problem resolution, etc.
Southwest Region	Assist MIT/LL with DEMVAL Phase I setup and conduct. Participate in biweekly telephone conference to discuss test status, problem resolution, etc.
ABQ Air Traffic	Coordinate NCP for DEMVAL Phase II tests. Participate in biweekly telephone conference to discuss test status, problem resolution, etc.

<u>Organization</u>	<u>Primary Role/Function</u>
MIT/LL	<p>Supply, operate, and maintain all WSP-related equipment.</p> <p>Conduct DEMVAL Phase I and Phase II activities per this FAA-approved DEMVAL Plan.</p> <p>Coordinate activities for flight inspections.</p> <p>Participate in biweekly telephone conference to discuss test status, problem resolution, etc.</p> <p>Familiarize Albuquerque AT with WSP products/functionality prior to Phase II commencement.</p> <p>Prepare DEMVAL Reports for Phase I and Phase II, including data analysis and test results.</p>

5.1.2 DEMVAL Test Plan Working Group (TPWG).

ACT-320 regularly chairs TPWG telecons (on a weekly or biweekly basis) as identified in the TEMP. All organizations listed in section 5.1.1 participate in these TPWG telecons.

5.1.3 DEMVAL Conduct Team.

MIT/LL and FAA Southwest region personnel (Phase I only) will conduct DEMVAL tests. AND-420, ACT-320, AOS-250, AOS-270, and ACT-421 (Phase I only) are monitoring DEMVAL tests.

5.2 TRAINING.

There is no formal training for DEMVAL testing. However, both MIT/LL and FAA Southwest region personnel require previous ASR system maintenance training to accomplish DEMVAL test activities.

5.3 SYSTEM CONFIGURATION MANAGEMENT.

5.3.1 Test Bed Configuration.

The MIT/LL test bed WSP is configured as identified in previous sections. A listing of the current configuration baseline status is included as appendix B.

5.3.2 DEMVAL Readiness Criteria.

DEMVAL readiness criteria include the following:

- a. availability of all hardware and communications lines,
- b. properly configured system including all necessary ASR-9 EEMs (Phase II only),
- c. full functionality and validation of WSP products to meet AT requirements (Phase II only),
- d. AT familiarization of WSP products/functionality must be completed prior to DEMVAL Phase II,
- e. all required NCPs approved.

5.4 DEMVAL ENTRY CRITERIA.

During MIT/LL WSP demonstrations conducted from 1987 through 1995, it was proven that the WSP provides useable and useful wind shear information to AT personnel (reference DOT/FAA/CT-TN92/48 and DOT/FAA/CT-TN94/4). This satisfies DEMVAL entry criteria.

5.5 DEMVAL EXECUTION.

DEMVAL activities are to be executed in accordance with the methods included in the ASR-9 maintenance handbook or in accordance with the methods approved by the TPWG.

5.6 DEMVAL EXIT CRITERIA.

Exit criteria for DEMVAL Phase I was the successful completion of the blue-sheet readings and the flight checks. However, it should be noted that since the WSP prototype system was not up to current baseline, the blue-sheet readings and subsequent flight check were accepted. Refer to the ACT-320 WSP DEMVAL Phase I Monitoring Report for Phase I test results and system baseline deficiencies.

Exit criteria for Phase II is the successful completion of the blue-sheet readings, and the successful demonstration that the re-engineered prototype, when interfaced with the ASR-9, does not cause significant degradation to the ASR-9 search radar performance, and that the resultant system allows for simultaneous target channel, AP-corrected six-level weather presentation, and WSP functionality. Additionally, if the system was alarm-free going into DEMVAL testing, the system shall remain alarm-free when DEMVAL is concluded.

5.7 DEMVAL REPORTS.

ACT-320 will prepare a monitoring report after both DEMVAL Phase I and Phase II tests.

Southwest region personnel will provide weekly activity reports to the test community when participating in DEMVAL activities (Phase I only).

MIT/LL will prepare a DEMVAL report after both Phase I and Phase II, to include data analysis and test results.

5.8 SYSTEM/OPERATIONAL DEFICIENCY REPORTS.

MIT/LL and/or FAA personnel may prepare deficiency reports, as necessary, to highlight system anomalies and failures and any corrective action taken. These deficiency reports shall contain as much supporting data and system information as appropriate to allow optimal troubleshooting and correction of the problem. Supporting data may include on-line and off-line information, any alarms present onscreen or in the buffer at time of failure, maintenance handbook or technical instruction (TI) procedure used to evaluate and/or correct failure, etc. ACT-320 will forward deficiency reports, if required, to AND-420 for problem resolution and system correction.

Although no deficiency reports were generated during Phase I testing, the reader is referred to the ACT-320 WSP DEMVAL Phase I Monitoring Report for Phase I test results and prototype system limitations.

5.9 DEMVAL SCHEDULE.

DEMVAL Phase I was conducted from November 1995 to January 1996. DEMVAL Phase II is currently underway and will continue through 1997.

5.10 PERSONNEL RESOURCE REQUIREMENTS.

ACT-320 and FAA Southwest Regional personnel (Phase I only) will assist MIT/LL personnel with DEMVAL activities, if required. In addition, MIT/LL will coordinate and arrange for both a pilot and aircraft to be used for the Phase I flight inspection.

For DEMVAL Phase II only, MIT/LL will ensure Albuquerque AT personnel are familiar with and comfortable using the WSP products and displays.

5.11 PLANNING CONSIDERATIONS AND LIMITATIONS.

The WSP DEMVAL does have limitations. For example, DEMVAL testing does not address the following issues:

- a. WSP RMF to ASR-9 Remote Monitoring Subsystem (RMS) interface;

- b. utilization of ASR-9 RF and digital test target generator signals for WSP self-test (no BIT/FIT); no RF/IF calibrator (required for problem detection and six-level weather calibration).
- c. some nonessential modifications to variable site parameters (VSP) and system firmware that may be appropriate to accommodate the presence of the WSP;
- d. full exploration of WSP interface options for feeding AP-corrected six-level weather data to controllers' DEDS and DBRITEs.
- e. Signal control lines will be tapped from existing circuits and will not be completely isolated and buffered.
- f. The Phase II prototype does not meet all FAA requirements for temperature, humidity, structural, etc., and will have no video I&Q balance.

With the possible exception of "a." above, all other listed issues will be addressed during System Test on the Limited Production (LP) WSP systems.

6. ACRONYMS AND ABBREVIATIONS

9-PAC	ASR-9 Processor Augmentation Card
ABQ	Albuquerque
ac	alternating current
A/D	Analog to Digital
AF	Airway Facilities
AGC	Automatic Gain Control
AMS	Acquisition Management System
AP	Anomalous Propagation
APG	Azimuth Pulse Generator
ARTS	Automated Radar Terminal System
ASR	Airport Surveillance Radar
AT	Air Traffic
ATC	Air Traffic Control
BIT	Built-In-Test
CENRAP	Center Radar ARTS Processing
CHG	Change
COI	Critical Operational Issue
COTS	Commercial Off-The-Shelf
CP	Circular Polarization
D	Demonstration
dB	decibel
DBRITE	Digital Bright Radar Indicator Tower Equipment
dc	direct current
DEDS	Data Entry and Display Subsystem
DEMVAL	Demonstration Validation
DF	Display Function
DSP	Digital Signal Processor
DT&E	Development Test and Evaluation
EEM	Electronic Equipment Modification
EEPROM	Electrically Erasable Programmable Read-Only Memory
FAA	Federal Aviation Administration
FIT	Fault Isolation Test
ft	feet
GSD	Geographic Situation Display
I&Q	In Phase and Quadrature
IF	Intermediate Frequency
kV	kilovolt
LNA	Low Noise Amplifier
LP	Limited Production
LP	Linear Polarization
mA	milliampere
MAOR	Minimum Acceptable Operational Requirement

MDS	Minimum Discernible Signal
MDT	Maintenance Data Terminal
MIP	Message Interface Processor
MIT/LL	Massachusetts Institute of Technology/Lincoln Laboratory
N/A	Not Applicable
NAS	National Airspace System
NCP	NAS Change Proposal
NF	Noise Figure
NIMS	NAS Infrastructure Management System
nmi	nautical mile
par	Paragraph
PAT&E	Production Acceptance Test and Evaluation
PD	Program Directive
PFN	Pulse Forming Network
PRF	Pulse Repetition Frequency
PROM	Programmable Read-Only-Memory
RAG	Range-Azimuth Gated
RDA	Radar Data Acquisition
RDP	Radar Data Processor
RDT	Ribbon Display Terminal
RF	radio frequency
RMF	Remote Monitoring Function
RMS	Remote Monitoring Subsystem
SCIP	Surveillance Communications Interface Processor
STC	Sensitivity Time Control
STU	System Timing Unit
T&E	Test and Evaluation
TDWR	Terminal Doppler Weather Radar
TEMP	Test and Evaluation Master Plan
TI	Technical Instruction Book
TPWG	Test Plan Working Group
TRACON	Terminal Radar Control
TRDF	Terminal Radar Development Facility
TRR	Test Readiness Review
uA	microampere
VRTM	Verification Requirements Traceability Matrix
VSP	Variable Site Parameter
VSWR	Voltage Standing Wave Ratio
WSP	Weather Systems Processor

APPENDIX A

**VERIFICATION REQUIREMENTS TRACEABILITY MATRIX (VRTM) - TRDF
PERFORMANCE PARAMETERS PER FAA ORDER 6310.19**

**Verification Requirements Traceability Matrix
Terminal Radar Development Facility (TRDF) - Performance Parameters**

TEST DESCR ID #	REQUIREMENTS	DESCRIPTION	DT&E	THRESHOLD	KEY CERTIFICATION PARAMETER?
101	Par 70. Average RF Power Output	TI 6310.25, par 6.3.1 (See note, table 6-1)	D	Calculated limits based on Commissioned value	Yes
102	Par 71a. RMS VSWR	TI 6310.25, par 6.3.1	D	< 1.5:1	Yes
103	Par 71b1. Calibrated VSWR at DC5, DC6	TI 6310.24, par 6.5.3	D	< 1.5:1	Yes
104	Par 71b2. Calibrated VSWR at DC8, DC9	TI 6310.24, par 6.5.3	D	< 1.43:1	Yes
105	Par 72a. RMS Pulse Width	TI 6310.25, par 6.3.1	D	0.93 to 1.10 us	
106	Par 72b(1). Detector Pulse Width (70% Amplitude)	TI 6310.25, par 7.8.5	D	0.99 to 1.05 us	Yes
107	Par 72b(2). Detector Rise Time (10% to 90% Amplitude)	TI 6310.25, par 7.8.5	D	0.11 to 0.18 us	Yes
108	Par 73a. Bandwidth at -40 dB Points	TI 6310.25, par 6.3.1.3	D	Calculated limits based on Commissioned values	Yes
109	Par 73b. Bandwidth at -50 dB Points	TI 6310.25, par 6.3.1.3	D	Calculated limits based on Commissioned values	Yes
110	Par 74a. Transmitter Filament Current Reading	TI 6310.25, par 205	D	± 1 Amp of nameplate value	
111	Par 74b. Transmitter Focus Coil Current	TI 6310.25, par 6.3.1	D	± 3 Amps of nameplate value	

D = Demonstration

**Verification Requirements Traceability Matrix
Terminal Radar Development Facility (TRDF) - Performance Parameters**

TEST DESCR ID #	REQUIREMENTS	DESCRIPTION	DT&E	THRESHOLD	KEY CERTIFICATION PARAMETER?
112	Par 74c. Transmitter Klystron Voltage	TI 6310.25, par 6.3.1	D	60.2 to 80.5 kV	
113	Par 74d. Transmitter Klystron Current	TI 6310.25, par 6.3.1	D	71.9 to 96.1 mA (\pm 4.0 mA) - PRF dependent	
114	Par 74e. Transmitter PFN Voltage	TI 6310.25, par 6.3.1	D	5100 to 6210 V dc	
115	Par 74f. Transmitter Vacuum Pump Current	TI 6310.25, par 6.3.1	D	\leq 21.9 uA	
116	Par 75a. All +5 V dc Power Supply Voltages	TI 6310.25, table 4-1	D	+4.50 to +5.50 V dc	
117	Par 80a. Target Receiver MDS High Beam	TI 6310.24, par 6.3.2.1	D	\leq -107 dBm	Yes
118	Par 80b. Target Receiver MDS Low Beam	TI 6310.24, par 6.3.2.1	D	\leq -107 dBm	Yes
119	Par 81a. Target Receiver NF High Beam	TI 6310.24, par 6.3.2.1	D	\leq 4.1 dB	Yes
120	Par 81b. Target Receiver Recovery - Low Beam	TI 6310.24, par 6.3.2.1	D	\leq 4.1 dB	Yes

D = Demonstration

**Verification Requirements Traceability Matrix
Terminal Radar Development Facility (TRDF) - Performance Parameters**

TEST DESCR ID #	REQUIREMENTS	DESCRIPTION	DT&E	THRESHOLD	KEY CERTIFICATION PARAMETER?
121	Par 82a. Target Receiver Recovery - High beam	TI 6310.24, par 6.3.2.2	D	≤ 4.1 dB	Yes
122	Par 82b. Target Receiver Recovery - Low beam	TI 6310.24, par 6.3.2.2	D	≤ +3 dB	Yes
123	Par 83. System Stability	TI 6310.24, par 6.3.4	D	≥ +55 dB	Yes

D = Demonstration

APPENDIX B

TRDF CONFIGURATION BASELINE STATUS

Table B-1, Terminal Radar Development Facility (TRDF) Configuration Baseline Status, is a complete and current (July 1997) list of Electronic Equipment Modifications (EEM) to the ASR-9. Columns two and three list the status of the TRDF at the completion of Phase I and beginning of Phase II DEMVAL testing.

Table B-1. TRDF Configuration Baseline Status

EEM Chapter, CHG #, Date	Phase I Status	Phase II Status	Description
Chapter 01 CHG N/A 9/11/90	Installed	Installed	Post-Processor Firmware
Chapter 02 CHG 01 3/13/91	Installed	Installed	Trigger Gate and Trigger Trap (superseded by later Chapter)
Chapter 03 CHG 02 5/28/91	Installed	Installed	Batch Control Sequencer/Message Interface Processor (MIP) Programmable Read-Only Memory (PROM)
Chapter 04 CHG 03 7/17/91	Installed	Installed	Weather Channel and Radar Receiver Processor Firmware FA-10067 and FA-10079
Chapter 05 CHG 07 9/30/91	Installed	Installed	Auto Restoration, Stability Measurement, Remote Monitoring Subsystem (RMS), Maintenance Processor Subsystem (MPS) Software, and Automated Radar Terminal System (ARTS) IIIA Capacity FA-10067, FA-10068, FA-10078, FA-10079, FA-10087, FA-10088, FA-10096
Chapter 06 CHG 05 7/24/91	Installed	Installed	System Stability FA-10065
Chapter 07 CHG 08 10/30/91	Installed	Installed	Transmitter C2 Replacement FA-10064
Chapter 08 CHG 09 11/4/91	Installed	Installed	Surveillance Communications Interface Processor (SCIP) Display Weather Video FA-10079, FA-10087, FA-10091
Chapter 09 CHG 10 12/23/91	Install Not Required	Install Not Required	Transmitter X-Ray Radiation Shield FA-10065
Chapter 10 CHG 11 12/23/91	Not Installed	No Kits Available	Radiating Assembly Roll Pin FA-10081

EEM Chapter, CHG #, Date	Phase I Status	Phase II Status	Description
Chapter 11 CHG 14 7/8/92	Installed	Installed	Trigger Trap Phase II - FA-10064, FA-10065, FA-10067, FA-10068 (Page change by CHG 15, dated 9/14/92)
Chapter 12 CHG 13 3/11/92	Not Installed	Installed	Post Processor - Secondary Azimuth Resolution - FA-10067, FA-10068
Chapter 13 CHG 16 10/14/92	Not Installed	Installed	Post Processor - Military Emergency, 7700 Code, FA-10067, FA-10068
Chapter 14 CHG 17 11/20/92	Not Installed	Installed	Post Processor Radar Centroiding FA-10067, FA-10068 (Page change by CHG 25, dated 1/20/94)
Chapter 15 CHG 22 12/2/93	Installed	Installed	RMS - Fault Log and Fault Isolation Test Update FA-10078
Chapter 16 CHG 19 8/20/93	Installed	Installed	Modulator Pulse Assembly and Oil Tank Replacement FA-10065 (Page change by CHG 30, dated 10/27/94)
Chapter 17 CHG 27 7/19/94	Installed	Installed	Arc Detector Shield Replacement FA-10065
Chapter 18 CHG 37 1/26/95	Not Installed	Installed	MODE-S/ASR-9 Interface FA-10067, FA-10068, FA-10079
Chapter 19 Change 21 12/2/93	Not Installed	Installed	Digital Signal Processor (DSP) Receiver Monitor - Sensitivity Time Control (STC) Built-In Test Upgrade FA-10067, FA-10068, FA-10079
Chapter 20 CHG 23 12/17/93	Not Installed	Installed But No FAA Kit	Air Compressor/Dehydrator FA-10064
Chapter 21 CHG 31 10/31/94	Not Installed	Installed	Wiring Changes to the Receiver and Weather Receiver/SCIP Backplanes, System Timing Unit (STU) B and Local System Control Interface #1 Boards, and Antenna Control Box
Chapter 22 CHG 24 1/4/94	Not Installed	Chapter 39 Supersedes	SCIP - Alignment Targets FA-10079, FA-10087, FA-10091 (Page change by CHG 29, dated 10/6/94)
Chapter 23 CHG 36 11/9/94	Not Installed	Installed	SCIP Display Timing for Center Radar Arts Processing (CENRAP)

EEM Chapter, CHG #, Date	Phase I Status	Phase II Status	Description
Chapter 24 CHG 28 8/4/94	Not Installed	Installed	Mode Select Beacon System alarms With Azimuth Pulse Generator (APG) Power Off
Chapter 25 CHG 33 11/2/94	Not Installed	Installed	MIP Electronically Erasable Programmable Read-Only Memory (EEPROM) Write Protect and the 9 PAC Status Register (Page change by CHG 38, dates 3/5/95)
Chapter 26 CHG 34 11/2/94	Not Installed	Installed	Pedestal Interlock
Chapter 27 CHG 35 11/1/94	Not Present	Installed	Correction to ASR-9 System Instruction Books
Chapter 28 CHG 46 12/12/95	Not Installed	Installed	APG +5 Volt Power Supply Fuses
Chapter 29 CHG 44 9/29/95	Not Installed	Installed	Modulator Pulse Assembly Ferrite Filter
Chapter 30 CHG 43 8/29/95	Not Installed	Installed	Transmitter Interlock
Chapter 31 CHG 41 7/10/95	Not Present	Installed	Second Set of Corrections to ASR-9 System Instruction Books
Chapter 32 CHG 42 7/17/95	Not Installed	Installed	Guard Code
Chapter 33		Go Back Team To Install	Reserved - Power Interrupt with Single Phase Loss
Chapter 34 CHG 47 5/21/96		Installed	MIP Board Update
Chapter 35 CHG 49 3/19/96		N/A	SCIP-Enroute ARTS Interface Update (for Enroute ARTS Co-Located Facilities Only)
Chapter 36		Phase I & Phase II	Reserved - Processor Augmentation Card

EEM Chapter, CHG #, Date	Phase I Status	Phase II Status	Description
Chapter 37		Go Back Team To Install	Reserved - Third Set of Corrections to ASR-9 System Instruction Books
Chapter 38		Not Scheduled	Reserved - Dual Redundant Alternative
Chapter 39		Installed	SCIP-ARTS III Alarms Message and Monitoring Upgrade
Chapter 40 CHG 55 2/25/97		Installed	Remote Monitoring Subsystem (RMS) Firmware And System Control And Configuration Firmware Upgrade

APPENDIX C
FLIGHT INSPECTION PLAN

FLIGHT INSPECTION PLAN

The purpose of a flight inspection is to determine how much attenuation would be required in the receive path of the ASR-9 in order to bring the outer coverage limit of the radar in to roughly 40 nautical miles (nmi). Under normal operating conditions, the ASR-9's coverage at higher altitudes exceeds the 60 nmi processing capability of the radar. In order to get a true picture of the outer coverage fringe, return signals must be attenuated so that they appear at a range which is capable of being processed.

The flight inspection plan was generated based on FAA flight inspection requirements from FAA Order 6300.13, Radar Systems Optimization and Flight Inspection Handbook. The flight plan was abbreviated in order to apply only those tests which were applicable to this demonstration.

Three tests were developed for the flight plan: vertical coverage outer fringe, vertical coverage inner fringe, and a high-beam range-azimuth gate (RAG) tracking evaluation. The fringe is defined as that area where radar coverage is lost on an aircraft due to energy return from the target which is not sufficient for target declaration in the case of the outer fringe, or entry into the "cone of silence" of the radar (the area over the antenna which is not illuminated by the beam due to its shape) in the case of the inner fringe. The fringe tests are FAA flight inspection standards which give a snapshot evaluation of the radar's performance. The high-beam RAG tracking evaluation was included to determine how target detection is affected in those areas unable to be compensated (via STC adjustment) for the 3 dB loss associated with the WSP hardware.

Channel A shall be configured as an ASR-9 with WSP hardware installed. Channel B shall be configured as a standard ASR-9. Both channels shall be equipped with Phase I ASR-9 Processor Augmentation Card (9-PAC).

All checks shall be performed with radar in CP and with matched 22 dB attenuators at the outputs of the Channel A and B Low Noise Amplifiers (LNA). All altitudes shall be referenced to the antenna feedhorn elevation (site elevation + tower height + 8 feet (ft)). Abbreviated vertical coverage to be performed on the 250 radial reference the MIT TRDF site.

A high-beam RAG shall be built with the following parameters: start range, 24 nmi; range extent, 2 nmi; start azimuth, 230 degrees; azimuth extent, 10 degrees. Primary surveillance tracking shall be evaluated through this area with both Channel A and Channel B.

VERTICAL COVERAGE, OUTER FRINGE:

1. Radar to be operating on Channel A. Established outbound on the 25 by roughly 10 nmi and from site at 1000 ft. Continue outbound until coverage is lost (will advise). Circle and repeat outbound at 1000 ft with Channel B on line (will advise established range).
2. Using Channel B, climb to 3000 ft and establish outbound by roughly 15 nmi from site. Continue outbound until coverage is lost. Circle and repeat outbound at 3000 ft with Channel A on line.

3. Using Channel A, climb to 5000 ft and establish outbound by roughly 15 nmi from site. Continue outbound until coverage is lost. Circle and repeat outbound at 5000 ft with Channel B on line.

4. Using Channel B, climb to 10,000 ft and establish outbound by roughly 25 nmi from site. Continue outbound until coverage is lost. Circle and repeat outbound at 10,000 ft with Channel A on line.

5. Using Channel A, climb to 15,000 ft and establish outbound by roughly 30 nmi from site. Continue outbound until coverage is lost. Circle and repeat outbound at 15,000 ft with Channel B on line.

VERTICAL COVERAGE, INNER FRINGE:

1. Climb to 15,000 ft. Using Channel A, establish inbound on the 250 by roughly 10 nmi from site. Continue inbound until over the radar. Circle and repeat inbound at 15,000 ft with Channel B on line (will advise established range).

2. Using Channel B, descend to 10,000 ft and establish inbound by roughly 10 nmi from site. Continue inbound until over the radar. Circle and repeat inbound at 10,000 ft with Channel A on line.

3. Using Channel A, descend to 5000 ft and establish inbound by roughly 5 nmi from site. Continue inbound until over the radar. Circle and repeat inbound at 5000 ft with Channel B on line.

4. Using Channel B, descend to 1000 ft and establish inbound by roughly 5 nmi from site. Continue inbound until over the radar. Circle and repeat inbound at 1000 ft with Channel A on line.

HIGH BEAM RAG TRACKING EVALUATION:

1. Using Channel A, track inbound through RAG at 15,000 ft, then circle and track outbound. Repeat using Channel B.

2. Descend to 10,000 ft. Track inbound through RAG using Channel B, then circle and track outbound. Repeat using Channel A.

3. Descend to 5,000 ft. Track inbound through RAG using Channel A, then circle and track outbound. Repeat using Channel B.