

129058

JPRS-UMM-84-005

19 March 1984

USSR Report

MACHINE TOOLS AND METALWORKING EQUIPMENT

DISTRIBUTION STATEMENT A
Approved for public release;
Distribution Unlimited

DTIC QUALITY INSPECTED 2

19980317 180

FBIS FOREIGN BROADCAST INFORMATION SERVICE

REPRODUCED BY
NATIONAL TECHNICAL
INFORMATION SERVICE
U.S. DEPARTMENT OF COMMERCE
SPRINGFIELD, VA. 22161

10
60
A04

NOTE

JPRS publications contain information primarily from foreign newspapers, periodicals and books, but also from news agency transmissions and broadcasts. Materials from foreign-language sources are translated; those from English-language sources are transcribed or reprinted, with the original phrasing and other characteristics retained.

Headlines, editorial reports, and material enclosed in brackets [] are supplied by JPRS. Processing indicators such as [Text] or [Excerpt] in the first line of each item, or following the last line of a brief, indicate how the original information was processed. Where no processing indicator is given, the information was summarized or extracted.

Unfamiliar names rendered phonetically or transliterated are enclosed in parentheses. Words or names preceded by a question mark and enclosed in parentheses were not clear in the original but have been supplied as appropriate in context. Other unattributed parenthetical notes within the body of an item originate with the source. Times within items are as given by source.

The contents of this publication in no way represent the policies, views or attitudes of the U.S. Government.

PROCUREMENT OF PUBLICATIONS

JPRS publications may be ordered from the National Technical Information Service (NTIS), Springfield, Virginia 22161. In ordering, it is recommended that the JPRS number, title, date and author, if applicable, of publication be cited.

Current JPRS publications are announced in Government Reports Announcements issued semimonthly by the NTIS, and are listed in the Monthly Catalog of U.S. Government Publications issued by the Superintendent of Documents, U.S. Government Printing Office, Washington, D.C. 20402.

Correspondence pertaining to matters other than procurement may be addressed to Joint Publications Research Service, 1000 North Glebe Road, Arlington, Virginia 22201.

Soviet books and journal articles displaying a copyright notice are reproduced and sold by NTIS with permission of the copyright agency of the Soviet Union. Permission for further reproduction must be obtained from copyright owner.

19 March 1984

USSR REPORT

MACHINE TOOLS AND METALWORKING EQUIPMENT

CONTENTS

INDUSTRY PLANNING AND ECONOMICS

| | |
|-----------------------------------------------------------------------------------------------------------------------------------------|----|
| Innovative Management, Pricing Features of Economic Experiment Discussed (L. Busyatskaya; PLANOVOYE KHOZYAYSTVO, No 10, Oct 83) | 1 |
| Report by Preparatory Commission on Machinebuilding Viewed (Ye. Spiridonov; IZVESTIYA, 22 Dec 83) | 7 |
| Status, Problems of Forge-Press Production Viewed (A. Pyatunin, V. Shilov; SOVETSKAYA ROSSIYA, 14 Jan 84) ... | 12 |
| Engineer Airs Frustration Over Pay, Paperwork, Trade Policies (Vladimir Pavlovich Kabaidze Interview; IZVESTIYA, 5 Dec 83) | 19 |
| Results of Experiment With Management, Production of Pipeline Machinery (G. Yastrebtsov; PRAVDA, 16 Jan 84) | 24 |
| Retraining Opportunities for NC Machine Operators, Programmers (Ye. Maliota; GUDOK, 14 Feb 84) | 29 |
| Computerized Procurement, Production, Inventory Control at Ukrainian Plant (A. Chepelev, A. Korin; RABOCHAYA GAZETA, 4 Oct 83) | 31 |
| Unification of Design Specs, Standards Urged (A. Fomin; EKONOMICHESKAYA GAZETA, No 35, Aug 83) | 35 |

METAL-CUTTING AND METAL-FORMING MACHINE TOOLS

| | |
|-------------------------------------------------------------------------------------------------------------------------------------------------------------------------|----|
| Technical Particulars of New Multi-Spindle Vertical Boring Mill Featured (Ye. A. Androychikov, L. V. Bader; STROITEL'NYYE I DOROZHNYYE MASHINY, No 12, Dec 83) | 37 |
|-------------------------------------------------------------------------------------------------------------------------------------------------------------------------|----|

| | |
|--------------------------------------------------------------------------------------------------------------------------------------|----|
| CNC Drilling-Counterboring Machine for PCB Production Introduced (EKONOMICHESKAYA GAZETA, No 1, Jan 84) | 40 |
| OTHER METALWORKING EQUIPMENT | |
| Design, Start-Up of Large Hot Rolling Mill Discussed (A. Slobodyanik, V. Seleznev; RABOCHAYA GAZETA, 28 Dec 83) | 42 |
| Minsk Kalibr Plant Retrofits With CNC To Improve PCB Production (G. Lukavets; SOVETSKAYA BELORUSSIYA, 25 Feb 84) | 44 |
| Reason for Slow Progress With Industrial Lasers in Belorussia Viewed (V. Volkov, A. Zayats; SOVETSKAYA BELORUSSIYA, 8 Jan 84). | 46 |
| Briefs | |
| Diamond-Wheel Cutter | 48 |
| Abrasive-Belt Machining | 48 |
| Drill, Mill, Assemble | 49 |
| Automated Service Centers | 49 |
| Grinders Lack Control Systems | 49 |
| Forge-Press Production | 49 |
| Electro-Slag Casting | 50 |
| Electrochemical Machining | 50 |
| Plasma Machining | 51 |
| AUTOMATED LINES AND AGGREGATED MACHINING SYSTEMS | |
| Czechoslovak NC Machine Tools to Soviet Auto Plants (KOMMUNIST, 16 Dec 83) | 52 |
| Some Electronic Control Features of FMS Viewed (V. Gerasimov; PRAVDA, 27 Dec 83) | 53 |
| ROBOTICS | |
| Development of Robots for Industry and Agriculture (SOVETSKAYA MOLODEZH', 21 Sep 83) | 55 |

INDUSTRY PLANNING AND ECONOMICS

INNOVATIVE MANAGEMENT, PRICING FEATURES OF ECONOMIC EXPERIMENT DISCUSSED

Moscow PLANOVOYE KHOZYAYSTVO in Russian No 10, Oct 83 pp 54-58

[Article by L. Busyatskaya, chief of the Planning and Economics Administration of the Ministry of Heavy and Transport Machinebuilding: "An Economic Experiment in the Ministry of Heavy and Transport Machinebuilding"]

[Text] In implementing the decisions of the 26th CPSU Congress and the subsequent CPSU Central Committee plenums on the improvement of the economic mechanism, the CPSU Central Committee and the USSR Council of Ministers decided to conduct in a number of ministries, including the Ministry of Heavy and Transport Machine Building, an economic experiment on the broadening of the rights of production associations (enterprises) in planning and economic activity and on the increase of their responsibility for the results of work. The task was posed to create on the basis of the improvement of planning work at associations (enterprises) such conditions which would stimulate high-quality, highly productive labor, initiative and enterprise and would ensure the acceleration of scientific and technical progress and the intensification of production.

The limitation of the number of indicators which are approved was outlined by the terms of the experiment. The indicators, which characterize the output of the most important types of products: the increase of labor productivity and the decrease of the expenditures on production; the implementation of scientific and technical programs on the development and introduction of new equipment and technology; the proportion of products of the highest quality category; the limit of state capital investments and the placement of production capacities into operation; the limit of material and technical resources, were kept. These measures make it possible to focus the attention of the managers of associations and enterprises and the entire collective on the main direction of activity and to meet more completely the needs of the national economy for advanced types of machines and equipment.

A new content was incorporated in the indicator "the production of the basic types of products in physical terms, including new equipment and products for export." The planning of the production of new items (the first industrial series and prototypes) is aimed at the acceleration of the technical improvement of industry and the creation of conditions, under which the interest in the development of new machines and equipment by the enterprises of the Ministry of Heavy and Transport Machine Building and of components and materials on the part of the enterprises of co-performer ministries is ensured.

Stable economic standards of the production development fund, the wage fund, the material incentive fund, the fund for the development of science and technology and the fund for sociocultural measures and housing construction will be approved in the five-year plan for the associations and enterprises. The standards, which have been elaborated and reported to the enterprises at the same time as the control figures of the five-year plan, are not subject to change and reapproval in the annual plans. Thus, a stimulus for the better use of all types of resources appears. Conditions of management, under which the amounts of assets for the retooling and improvement of production, wages, the implementation of social measures and material stimulation will depend during the entire five-year plan on the final results of activity, are guaranteed to the production associations (enterprises).

The decision on the drawing up and approval in the five-year plans of a nominal list of equipment with a long production cycle with the indication of its specific types and the projects, at which it is installed, is a fundamentally important feature. This creates the prerequisites for high-quality and timely designing, the proper preparation of production and the better utilization of capacities.

It is envisaged to determine the production volume in value terms and the other value indicators of the plan on the basis of the assignments of the state plan on the output of the most important types of products in physical terms and the concluded contracts for their delivery. The associations and enterprises in this case will devote more attention to the more complete meeting of the needs of clients for the assortment of products by type sizes and modifications. At the stage of the formulation of the draft of the plan such a procedure requires the closer work of the enterprises with the marketing organizations and the USSR State Planning Committee, in which the specific orders of consumers for items, which are produced by the associations and enterprises, are concentrated.

It is necessary to carry out the drafting and approval of the annual plans of the production and distribution of products and the delivery of the funds for material and technical resources to the production associations and enterprises simultaneously during periods which exclude the advance indent of material and technical resources. For this it is necessary, in our opinion, for the USSR State Planning Committee and the USSR State Committee for Material and Technical Supply to report by 15 September to the ministry in accordance with the products list attached to them the planned production volume in accordance with the products list and the assets for the basic types of material and technical resources. Only individual revisions are permissible after the approval of the state plan.

The increase of the responsibility of the territorial organs of the USSR State Committee for Material and Technical Supply for the supply of the associations and enterprises of the ministry with material and technical resources is envisaged. In particular, the supply of the latter, first of all with metal, from the warehouses of the territorial administrations of the USSR State Committee for Material and Technical Supply and the centralized delivery of freight from the warehouses and bases in accordance with coordinated schedules are being increased. These measures are aimed not only at the achievement of a better

balance of the plans of production with resources, but also at the decrease of the above-standard stocks of materials and components.

In the annual plan the indicator of the volume of sold products will be established for the associations and enterprises for the evaluation of the fulfillment of the obligations on deliveries of products in conformity with the concluded contracts. The orders for the delivery of the final product will be the basis for all contractual relations. They should be issued for material and technical resources and components with allowance made for the dates of delivery of basic technological equipment. A delay with registration and the incomplete allocation of assets for resources are not permitted under the terms of the experiment. The punctual filling by the suppliers of rolled metal products and components of their supply orders and contracts, which have been concluded with the associations and enterprises of the ministry, is also necessary.

The reorganization of the work on the concluding of contracts is already being carried out directly at the associations and enterprises, the system of process planning is being adjusted so that items would be put into production on dates which ensure their timely delivery. Since up to 45 days are spent on the shipment and loading onto railroad flatcars of large single-design equipment with a long production cycle, the planning organizations have been commissioned to specify the procedure of keeping record of the fulfillment by the production associations of the ministry of the obligations on the deliveries of individual types of machines and equipment. In accordance with the prevailing legislation their delivery before 10 January (series-produced) and before 10 March (single-design) is permitted.

The overall evaluation in accordance with the results of the work and the socialist competition of the production associations and enterprises, which are participating in the experiment, is made by superior organizations and local organs in case of the fulfillment of the plan assignments on the volume of product sales in conformity with the demands of the contracts on its list (assortment), quality and dates of delivery, the basic assignments on the development of science and technology, as well as the assignments on the increase of the technical level (quality) of products and the placement into operation of new production capacities and facilities.

Thus, the number of evaluation indicators is reduced and the attention of the associations and enterprises is focused on the achievement of high end results of activity.

The enterprises are granted the right to establish independently with the participation of the clients the possible delivery date of products, if the orders for their production are issued with a deviation from the dates stipulated by the statute on deliveries. In case of the complete observance of the contract terms the material incentive funds are increased by 15 percent. For each percent of the nonfulfillment of the sales plan with allowance made for the obligations on deliveries in conformity with the concluded contracts these funds are reduced by 3 percent. It has been established that the bonuses for the managerial personnel of the production associations are paid only in case of the fulfillment of the plan assignments on the volume of product sales.

The expenditures on the retooling of works by means of the assets of the development fund will be included in the state capital investments and will be singled out in the plan separately as noncentralized expenditures. The possibility of using long-term credits for the implementation of highly effective measures on the replacement of fixed capital, as well as the assets intended for capital repair is envisaged. The reflection in the state plan of the work on retooling and the supply with material and technical resources, equipment and, as the need arises, limits for the contract are an important feature.

The economic efficiency of the measures, which are being implemented by means of the assets of the development fund, on the retooling of the fixed capital and the increase of capacities will be calculated by the associations and enterprises at the same time as the submitting of the drafts of the plans for the corresponding year being planned for recording in the sections and indicators of the state plans of economic and social development, that is, is under state control.

The production associations (enterprises) have been given the right to dispose independently of a portion of the assets of the unified fund for the development of science and technology for the performance on their own initiative of planning and designing work on the development of new items, as well as for the reimbursement of the increased expenditures during the period of its assimilation. In case of the temporary worsening of the indicators during the period of the mass assimilation of new highly productive equipment the decrease of the wage and material incentive funds of the associations (enterprises) will be offset by means of the corresponding centralized reserves and funds of the ministry.

For the purpose of increasing the interest in the acceleration of scientific and technical progress it is envisaged to pay one-time bonuses from the material incentive fund (up to three salaries in excess of the established maximum amounts of the payment of bonuses) to the managerial personnel of those associations (enterprises) which fulfill the plan assignments on the output of products, which correspond to the best domestic and world models, and the annual plan of product sales with allowance made for the obligations in accordance with the contracts. At the same time in case of the nonfulfillment of the plans and assignments on the development and assimilation of new equipment and the introduction of advanced technology and advanced know-how the bonuses for the basis results of economic activity are reduced by not less than 25 percent. It is permitted to transfer to other ministries assets (from the appropriate fund) for the payment of bonuses to the workers of the organizations subordinate to them for the early and high-quality fulfillment of the contractual work connected with the development, assimilation and introduction of new equipment.

The stimulation of scientists, designers, process engineers, planners, engineers and other specialists, who are involved in the development and production of products, which in their qualitative characteristics are not inferior to the world technical and economic level and meet the long-range demands of the consumers, has not been ignored. They can receive up to three salaries a year in excess of the bonuses which are stipulated by the prevailing statutes on the payment of bonuses.

The procedure of formalizing the prices and surcharges on the products being produced has been simplified and expedited. The associations and enterprises have been granted the right to approve independently in consultation with the client the wholesale prices for trial runs (prototypes) of items for production engineering purposes, if approved prices for them are lacking; for semi-finished products, assemblies and parts for intraministerial use, as well as the surcharges (or price reductions) in case of the making at the request of the client (customer) of changes in the list of machines (equipment) for a single order and the meeting of the demands, which have been submitted for approval to the client, on the improvement of individual technical and economic indicators, including for the increase of the service life of items.

For the purpose of stimulating the production and the expansion of the export of machine building products the production associations (enterprises) of the ministry are permitted to use incentive markups on the wholesale prices of the domestic market for products with the State Seal of Quality and products being supplied for export during the term of effect of these markups.

The changeover to standard methods of the formation of the funds for the remuneration of labor--the wage fund and the material incentive fund--serves the increase of the cost accounting interest and responsibility of the production collectives for the end results of the work. Starting in 1984 the wage fund of industrial personnel engaged directly in production will be formed in accordance with the standards of the wage per ruble of output. This is important for the observance of economically sound ratios between the increase of labor productivity and the increase of the average wage. On the basis of the gained experience it is planned to calculate the labor productivity and the standard of the wage according to the indicator of the net (standard) output, which reflects more accurately than other volume indicators the collective's own labor expenditures.

In case of the placement of large production capacities into operation an additional wage fund will be allocated for the period of the planned time of the achievement of the rated technical and economic indicators. If the association (enterprise) achieved these indicators with a smaller number of workers, the saving of the wage fund is left at its disposal.

In consultation with the trade union committee increased supplementary payments to the wage rates for occupational skill and for the combining of occupations, increased salaries for highly skilled workers, who are employed in especially important and responsible jobs, as well as increments for highly skilled engineering and technical personnel and employees with allowance made for the personal contribution of each person to the development and introduction of new highly efficient equipment and technology, the decrease of the labor intensity, materials-output ratio and power-output ratio and the increase of the quality of the products being produced can be established for the workers by means of the saving of the wage fund.

It is envisaged to form the material incentive fund on the basis of the amounts of the fund of the base year, which was formed in accordance with the plan, and the additional deductions in accordance with the standards for each percent of the decrease of the expenditures per ruble of commodity production as compared

with the base year. The absolute amount of the deductions for the material incentive fund during the fulfillment of the annual plans is increased (decreased) subject to the fulfillment of the plan of product sales with allowance made for the obligations on deliveries in conformity with the concluded contracts, the increase of the production of consumer goods per ruble of the wage fund, the additional profit, which was actually obtained due to the incentive mark-ups on the wholesale prices for new highly efficient products, which correspond to the best domestic and foreign models, and for products with the State Seal of Quality.

The enterprises are receiving more rights in the area of the use of the assets of the fund for sociocultural measures and housing construction. They will be formed from the sum of this fund according to the plan of the base year and the sum of the increase of the fund (2 percent for each percent of the increase of labor productivity, which is calculated by a cumulative total to the base year). The material resources and the amount of contracting work, which are necessary for the implementation of measures at the expense of the mentioned fund, are envisaged in the plan in the full amount and are reflected separately. The labor collectives have been afforded the opportunity to settle themselves the questions of the use of the available assets. The fund for sociocultural measures and housing construction should gradually become the basic source of the improvement of the social, housing and living conditions of the workers of the enterprises.

The use of the standard method of the distribution of the profit is being expanded and its effectiveness is being increased.

For the purpose of increasing the responsibility of the production associations (enterprises) for the efficient use of productive capital the ministry is permitted to introduce an additional fee (in excess of the one which had been established and is assigned to the budget) for the above-standard reserves of commodity stocks, for which credit has not been extended by the bank, and uninstalled equipment in the amount of up to 3 percent of their value and to allocate it for the financing of the expenditures of the ministry.

The term of the granting to the enterprises and organizations of payment credits is being increased from 60 to 90 days. The executives of the banks can extend this term to 120 days, as well as differentiate (decrease or increase by up to 20 percent) the interest rates for credit, subject to the fulfillment of the basic plan indicators, the use of working capital and the decrease (increase) of the above-standard reserves of commodity stocks.

The ministry is taking specific steps on the implementation of the decrees of the CPSU Central Committee and the USSR Council of Ministers on the conducting of the economic experiment. A permanent commission under the chairmanship of the minister, which checks the implementation of the measures on the preparation and conducting of the experiment, has been formed. The drafting of the necessary procedural instructions is being carried out. Everything is aimed at ensuring in the sector the increase of production efficiency and the fulfillment of the established plan assignments.

COPYRIGHT: Izdatel'stvo "Ekonomika". "Planovoye khozyaystvo". 1983

7807

CSO: 1823/124

INDUSTRY PLANNING AND ECONOMICS

REPORT BY PREPARATORY COMMISSION ON MACHINEBUILDING VIEWED

Moscow IZVESTIYA in Russian 22 Dec 83 p 2

[Article by Ye. Spiridonov under the heading "Between USSR Supreme Soviet Sessions": "Reliability of Deliveries (Meeting of the Machinebuilding Preparatory Commission)"]

[Text] Machinebuilding has priority in the economy of our country. It occupies first place in terms of overall volume of output produced, value of fixed production assets and number of personnel. Naturally, as the state plans for economic and social development are being worked out for the next year of the five-year plan, USSR Supreme Soviet deputies are interested foremost in how this complex of branches of heavy industry will be developed, as they are called on to provide the national economy with improved tools of labor. Do the plan indicators reflect adequately the party and government demand to ensure the outstripping development of machinebuilding and metalworking? How are the technical level and quality of products being improved? What about their cost, productiveness and reliability? The preparatory commission on machinebuilding has carefully examined the work of 11 ministries from these points of view.

The rates of machinebuilding development this past year were higher than those for industry as a whole. In terms of commodity output, for example, they were 4.1 and 3.7 percent, respectively. Labor productivity also rose faster. This was reported to the deputies by L. Voronin, First Deputy Chairman of the USSR Gosplan. However, relatively positive volume indicators produced no placidity in the atmosphere in which the discussion of branch operation was held. The criteria used by preparatory commission members in evaluating the results of economic activity in particular branches was the level of satisfaction of national economic requirements. This measure of success enabled them to remove the mask of enchantment from other plan figures and reveal their dull expression in physical terms.

Thus, speaking about the active participation of branch workers in carrying out the USSR Food Program, E. Kalinin, First Deputy Minister of Tractor and Agricultural Machinebuilding, gave as an example the forced production of levelers for the K-700 and T-150 tractors and cited what appeared at first glance to be impressive figures: 6,500 nine-base plows alone were produced this year; next year, that figure will double. But then deputy V. Myasoyedov, an economist at

a Kuybyshev plant, asked a very logical question: how is the manufacture of tractor-drawn agricultural implements linked to the production of powerful tractors? It turns out, to the astonishment of branch leaders, that the growth in plow production is downright miserly compared to the demand: several-fold more tractors which use long-base plows are being manufactured.

It was revealed in the course of the discussion that two-fold fewer toothed harrows are being manufactured by branch enterprises than the norm calls for. In certain oblasts and republics, the sowing is done without harrowing because of this, leading to high moisture losses. This "relapse" was the basis for critical conclusions by the preparatory commission. R. Bobvikov, first secretary of the Vladimir obkom and head of the commission, declared to those present that the deputies were notifying the ministry that inadequate consideration was being given to the actual needs of the national economy when drawing up branch production plans.

One might think the preparatory commission was composed of naive people, to view as "criminal" only the fact that there was a shortage of plows and harrows. Machinebuilders, after all, provide many other grounds for serious charges about their deliveries.

The deputies did not, of course, miss the point. The deputy ministers of power machinebuilding, heavy and transport machinebuilding, electrical engineering, automotive, machine-tool and tool-building industry were called to account at the commission meeting for failures to deliver sufficient turbines, diesels, electric motors and automated lines. And the justification that contract obligations were met at a 97-percent level, permissible under current USSR Gosplan norms, was not accepted for any of them. Deputy Yu. Kosyak, chief designer at the "Kharkov Turbine Plant" association, graphically demonstrated what this legal "amnesty" signifies in the delivery plan for the Ministry of Heavy and Transport Machinebuilding. This year, branch enterprises had a shortfall of something like 180 million rubles in deliveries to consumers. In view of the billions in production volume, this is not all that much. But the enterprises of the ministry have a products list number upwards of 4,000 items. And when you begin to analyze what form this indebtedness to customers took, it becomes clear that almost every enterprise failed to fully meet its contract obligations. Only 16 percent of the collectives were clear with the customer.

Then, too, the Ministry of Heavy and Transport Machinebuilding, like the Ministry of Electrical Engineering Industry, is a participant in the economic experiment beginning next year to broaden the rights of enterprises in these ministries regarding planning and economic activity and to increase their responsibility for work results. Increasing the demands on labor collectives in these branches will be expressed, in particular, in the fact that delivery plan fulfillment will become for them the primary reporting indicator linked to the material incentives fund. It is not hard to imagine the financial position they could find themselves in if delivery discipline remains at its previous level.

Deputy Minister of Heavy and Transport Machinebuilding R. Matveyev gave as the basic reason for the failure of enterprises to meet contract obligations difficulties in material-technical supply. This year [1983], for example, metal suppliers owed the branch 45,000 tons of rolled metal and an equal amount of cast

iron, which is right at 13 percent of the amount required. They also recorded delivery shortfalls of upwards of 6,000 motors of different kinds, 900,000 bearings and 20,000 cubic meters of lumber. Short deliveries of these material resources were also the cause of plan nonfulfillment in terms of products list.

Metal is called the bread of industry, and for machinebuilding branches the comparison is literal. All their output is, after all, "iron." At the same time, deliveries "crack" first of all when metal is lacking, and not just at enterprises of the Ministry of Heavy and Transport Machinebuilding. As the commission worked on the 1984 production plan, the Ministry of Tractor and Agricultural Machinebuilding, for example, was short several tens of thousands of tons of rolled ferrous metal. Could this be explained by some spontaneous planning malfunction? "No," answer the [ministry] leaders. "We have not gotten rid of the 'air' in material-technical supply plans, unfortunately." It was for good reason that a meeting of the CPSU Central Committee Politburo, after discussing progress in preparing for the economic experiment, noted that central agencies had not yet implemented the entire complex of measures ensuring efficient enterprise operation. The demand that the USSR Gosplan and Gossnab balance the release of output with material resources therefore remains urgent.

However, it is not just a question of production and supply plans sometimes not interfacing. The customer sometimes fails to receive output in the necessary amount and products list because related suppliers participating in its manufacture are indistinctly aware of what blame they will bear for failing to meet their obligations. And that means responsibility is diffuse. Deputy Minister of Automotive Industry A. Borzunov said, in this connection, "So we are reporting to the deputies that we delivered fewer bearings than were needed. We are clearly at fault: because of us, the customer was out cars and vehicles. But it is also obvious that, in this instance, greater demands should be made on metallurgists than, say, on the No 6 State Bearing Plant. It received no special steel from Dnepropetrovsk, and you can't make bearings out of wood."

What share of the blame should be borne by automobile manufacturers in such a case? At the time of the commission meeting, about 4,000 vehicles had accumulated at the Kama and Kremenchug plants but could not be shipped out because railroad workers had not supplied the needed number of cars for loading. Quite a few examples could be given in which material-technical supply agencies should bear the responsibility for delivery disruptions rather than the manufacturers: many types of metal needed in small quantities should have been received, under the contract, by the enterprise from the local UMTS [material-technical supply administration] depot, but it was all out.

In short, at a time when meeting contract obligations is becoming the primary criterion in evaluating enterprise operations, relations among related suppliers acquire an especially fundamental character. Neither reciprocal amnesties nor fines (which are recompensed through counter sanctions) can effectively strengthen cooperative ties; this must be done through full reimbursement of losses according to the degree of fault for delivery disruptions. The leaders of ministries to participate in the experiment are therefore of the opinion that it is time the USSR Gosplan and State Committee for Labor and Social Problems work out an integrated indicator for meeting contract obligations. What form do they

think it should take? One which would objectively determine the level of fault for failure to honor a contract as a function of the measure of related-supplier participation in producing the output and which would evaluate the work. If there is no continuous responsibility for meeting deliveries, the enterprises of the ministries participating in the experiment could be overwhelmed by the nonobligatory nature of their ties with partners in other branches and departments.

The economy of our country has embarked on an intensive path of development, in which the end results of production must grow faster than expenditures on it. And this means that today's machinebuilding is expected to produce equipment at a level which will permit a reduction in the national economic demand for tools of labor.

At the start of the five-year plan, a meeting of the machinebuilding preparatory commission criticized the Ministry of Heavy and Transport Machinebuilding for the low technical level of output being supplied the Ministry of Railways. As branch leaders reported to the deputies, the situation has changed radically: 80 percent of the products list against which claims had been made now corresponds to the best domestic and foreign models. For example, all cars manufactured by enterprises since the end of last year now have only roller bearings, which has significantly simplified their operation and increased their durability. The ministry was criticized as well for the wooden sheathing in closed cars. Now, only metal ones are produced. During 1981-1983, branch enterprises supplied the Ministry of Railways with tens of thousands of specialized cars for shipping bulk freight. The customer needed 104,000 fewer freight handlers. Neither should we fail to note the improvement in the operating qualities of diesel locomotives. This year, for example, we began series producing 9,000-hp locomotives. Starting next year, we will set up the mass production of 12,000-hp locomotives for the BAM.

However, no matter how perfect a machine may be in the heads of the designers and technologists, it will be as it is manufactured. And the deputies do have foundation for reproaching branch workers for poor-quality manufacturing. The results of a check of technological discipline at 56 enterprises of the Ministry of Heavy and Transport Machinebuilding were announced during the commission meeting, and it turned out that deviations had been discovered at 37, including ones which forced the stoppage of shipments.

As was noted in the CPSU Central Committee and USSR Council of Ministers decree "On Steps to Strengthen Scientific-Technical Progress in the National Economy," there is still inadequate responsibility for the technical level of production and for output quality at many ministries and departments, associations and enterprises. Preparatory commission members also came to this conclusion regarding the machinebuilding branches. The products list of each of them doubtless contains items which are the equal of foreign analogs or superior to them in terms of technical-economic indicators. But is there much new output in series production which has been mastered first in the USSR? Only 2.3 percent in machinebuilding as a whole. Incentives to scientific-technical progress are not yet operating fully here. And product quality suffers due to insufficiently high labor organization and to violations of production and technological discipline. Up to 0.8 percent of the available working time was lost this year due to absenteeism and downtime in machinebuilding.

All preparatory commission observations and recommendations concerning reserves for better satisfaction of national economic requirements by the machinebuilding branches became part of the conclusions of the planning-budgetary and other standing commissions of the chambers concerning the USSR State Economic and Social Development Plan and USSR State Budget for 1984.

Machinebuilding is the leading sector of the economy. With the production and scientific potential available to its branches, its workers can be in the very vanguard of technical progress. Discussion of the results of the economic activity of the machinebuilding branches at the preparatory commission demonstrated that for this to occur, we need first of all to exhibit maximum organization, responsibility and efficiency. And that applies to everyone, to those operating the machine tools and to those holding the reins of government in the branch.

11052

CSO: 1823/97

INDUSTRY PLANNING AND ECONOMICS

STATUS, PROBLEMS OF FORGE-PRESS PRODUCTION VIEWED

Moscow SOVETSKAYA ROSSIYA in Russian 14 Jan 84 pp 1, 3

[Article by A. Pyatunin and V. Shilov: "Strategy of Machine Tool Building"]

[Text] We observed the operation of a powerful sheet-stamping press at the Voronezh Agricultural Machine Building Plant. Recently, it was coupled with a robot. The work was not harmonious at first. Adjusters sent by the manufacturer were nervous and brigade leader Sergey Bulgakov was swearing. There was a desire to drive the clumsy robot out of the shop, but such "counter-revolutionary" action with respect to technical progress was not permitted. Gradually, the robot and the press learned to "understand" each other and everything went smoothly.

"Now everything is in order!" the pleased brigade leader told us. "We produce 100 parts in six minutes, several times more than before."

The deputy director, present at our conversation, added:

"The most convenient thing is that the manipulator can be switched off and we can operate in the manual feed mode..."

"But why switch him off?" we wondered.

"Because, you see, so that it does not block up the next section with intermediate products. There are no robots there so far. We are only getting ready to order them..."

In a minor episode, as in a drop of water, is seen the tortuous and contradictory progress of production reequipment: on the one hand there are obvious advantages of automation, but there is not enough of it; on the other hand, its advantages are not utilized to the fullest because the workers lack skill and experience, while some plant administrators lack a sensible comprehensive approach to solving the problem. When all these plant "drops" gather into one, then the problem will assume the size of an ocean on the scale of the national economy.

Unemployed Universal Machines

There are several million metal-cutting machine tools in our country. Their number is increased annually by hundreds of thousands of units. Impressive figures! But... On one hand, the cited statistic attests to the power of our machine tool building, while on the other hand, it attests to the inertia of its technical strategy. This fact evokes especially great concern because the structure of the metal-working equipment determines, to a considerable degree, the efficiency of industrial production and, primarily, of the machinebuilding sectors.

Once in two-three years, statistical organs check on how metal-working equipment is being utilized at machinebuilding enterprises in the whole country. Here is what was found by the investigation at plants of the Voronezh Oblast. Of 10,000 metal-cutting machine tools, over 3000 are inactive. The shift coefficient of such equipment not only did not grow, but even decreased somewhat. Each machine tool operates less than one-and-a-half shifts on the average. The Voronezh situation is characteristic of the country as a whole. The main reason is the lack of machine tool operators. What happens? We cannot take care of available work positions, while the building of powerful machine tools stubbornly multiplies the number of unemployed machine tools, immobilizing in this way millions of tons of metal and the live labor of hundreds of thousands of people. The other side of the problem is that metal-cutting machine tools are basic producers of chips. The work is useless, but expensive. Each ton of chips costs the national economy 640 rubles. How much do we lose if the total amount of chips exceeds nine million tons?"

It is not difficult to calculate.

Thus, from the economic and social viewpoints, metal-cutting machine tools lose their previous positions and become, to a greater degree, a brake on intensifying machinebuilding production. What does scientific technological progress promise us? Replace the machining of metal, for example, by precision stamping. Then when working each million tons of rolled stock, we save 250,000 tons of metal and free over 20,000 workers. On the national scale, the advantage would be a saving of several million tons of rolled stock and almost 500,000 workers. Both are very scarce today. There is only one conclusion: national economic interests demand that machinebuilding be changed decisively to the wider utilization of progressive technology and equipment corresponding to it. How is the reversal of technical strategy in the Minstankoprom [Ministry of Machine Tool and Tool Industry] proceeding? We will pass from the idea to the introduction.

"Our collective proposed many progressive innovations to 17 related plants," stated K. Golyavin, chief of the Voronezh Bureau of Forge-Press Machines and Automatic Lines. "We designed automatic high productivity, high-speed stamping machines, horizontal automatic machines for cold extrusion and an entire series of automatic presses for powder metallurgy.

Dozens of forge-press machines and automatic lines for waste-free and low-waste technology for metal-working were created by the collectives of the Experimental Scientific Research Institute (ENIIK mash), as well as by the design bureaus of the main plants in the sector. Many presses and automatic machines exceed the technical characteristics of similar machines made abroad. Five years ago, designers of the "Voronezh tyazhmekhprom" Production Association created an entirely new type of equipment -- a hot stamping double action set for precision extrusion without defects. The first such press after being demonstrated at the Milan International Exhibition was immediately purchased by one Italian firm and two months later was stamping cross-plates of universal shafts for automobiles. Soon three such presses were purchased by French firms and recently a license was sold to Hungary.

Thus, our designers proved that they can create forge-press equipment second to none in the world specimens. This means that the problem lies in organizing series production of progressive equipment and introducing it in production. However, so far, new domestic machines, automatic machines and sets are manufactured in small lots. Only 15 Voronezh presses, which interested foreign firms, were supplied to enterprises in our country. Furthermore, at most plants intermediate products are drilled, planed and milled on universal metal-cutting machine tools that, according to the Central Statistical Administration, are not fully utilized in machinebuilding enterprises even in one-and-a-half shifts.

The Press Seeks a Customer

Why does the structure of the machine tool pool change slowly? Why cannot the share of forge-press equipment reach the optimal level?

"We can produce more machines and automated equipment for them," stated M. Selin, chief engineer of the "Soyuzmash" All Union Production Association, "but progressive even robotized equipment frequently finds no customer demand. Therefore, for example, at our Barnaul Plant, it was necessary to delay the production of industrial manipulators artificially reducing the plan."

Five years ago, the collective of the ENIIK mash together with the Voronezh Plant imeni Kalinin were instructed to manufacture 12 automatic sets using forged rollers for enterprises of the Ministry of the Automobile Industry. However, they refused the first such set for no good reason. The Odessa press builders manufactured automatic hydraulic rotational machines for pressing products made of plastics. The new presses acquitted themselves well at chemical industry enterprises. Yet, it was literally necessary to beg for an order for them. The Kalinin people were also unlucky with their latest innovation. The plant manufactured a 500-ton automatic double-eccentric press for stamping parts from a narrow strip. A Tula Combine Plant that ordered this press refused to accept it and continued to use old, manually controlled presses. This list can be continued for a long time. Meanwhile, the decree of the CPSU Central Committee and the USSR Council of Ministers on accelerating technical progress in the national economy specified that customers carry material responsibility for refusing to accept equipment they ordered or for taking a long time to introduce it in production.

Why is production so difficult?

"The main reason is that the problems of specialization of forge-press production are being solved very slowly," V. Karzhan, director of the ENIIK Mash told us. Yet, without that solution, it is difficult to count on efficient reorganization of all machinebuilding.

What is the essence of the situation? We held a course on building comprehensive machinebuilding plants which produced their own castings, intermediate products and fixtures. All this was frequently manufactured under fairly primitive conditions and with high overhead costs. The ministries zealously guard their departmental independence and do not hasten interindustrial and regional specialization, although it could be of a large economic benefit to the country. In fact, the advantage of large intermediate product production is entirely unquestionable: the coefficient of metal utilization is increased by 12 percent, the production cost of a ton of forgings is reduced by 18 percent and the output per worker is increased by 30 percent. It is worthwhile here to look at experience abroad. Even "Ford" has no intermediate product production at its automobile plants because there exists a special sector "Production of steel forgings." It supplies steel forgings to all the plants in the country.

The second side of the problem is introducing highly effective technological processes that make it possible to have the shape of the intermediate product as close as possible to the shape of the finished product. At the main plants of the sector, including the "Voronezh tyazhmashpress," high productivity crank-driven hot stamping presses for precise stamping are already being made. The same results will be produced by cold extrusion, embossing, powder metallurgy and other processes. But so far, these progressive methods are used on a very limited scale. Suppliers of forgings are not at all interested in shaping them as closely as possible to the shape of the parts. They still take on heavy forgings with large allowances. Yet, the production of small and medium size forgings is even being reduced. The situation is that for them the plan and accounting production unit is the tonnage of output. The system of existing standards and wholesale prices does not provide proper incentives for the accuracy of the forgings. But is it not here that the flow of chips begins?

How Much Will the Chips Twist?

Specialists see a way out in the following. First, introduce corrections in standards and wholesale prices so that manufacturers become economically interested in producing precise and very precise forged and stamped intermediate products. Secondly, it is necessary to accelerate the improvement of the forge-press equipment itself, increase the production of presses for low-waste and waste-free technology, introduce in production new progressive methods more widely for metal-working and provide better incentives for the creators of such new equipment and technology. What is retarding these "first" and "second?"

We had an interesting talk with T. Fil'kin, chief designer of the "Voronezhztyazhmekhpess."

"In my opinion, we do not have a single policy in design and production of new equipment so far," he said. "The development of forge-press plants and of the material base of consumers, and their products are not coordinated. There is no clear line on how to build and what equipment to supply. I repeat, there are no such comprehensive interindustrial plans for rebuilding. Each department threshes its shock of wheat and carries out its own policy. Frequently, there is simply no place to install new equipment. It is interspersed in old shops where an automatic press stands beside a machine tool with manual control. Such disparity may be seen even at leading enterprises. An authoritative coordinating organ is required as well as a well-thought-out program for rebuilding machinebuilding enterprises."

"It is now necessary to build entire equipment complexes with mechanization and automation facilities, lines, sections and even shops. This job is frequently delayed not by some part or scarce material, but by a lack of entire production subdivisions. We do everything ourselves. Therefore, new equipment, new special services with skilled dispatchers, operators and control system adjusters are needed."

"Modernization and reequipment of an entire sector is not an easy job. It cannot be overcome by a cavalry attack. Time and thoughtful tedious work are needed. With the modern production scale and equipment development, it is impossible to span all enterprises at once. But it is possible to start with each ministry creating at least one demonstration model of production to teach people graphically. It is time to think seriously about a special technological institute on metal-working by pressure."

Finally, another thing must be mentioned. Serious shortcomings in planning the output of new equipment still remains. What does the USSR Gosstab think about that? M. Fedorov, deputy chief of the "Soyuzglavstankoinstrument," A. Dubrovin, chief of the Forge-Press Equipment Department, his deputy A. Zubchenko and leading engineer Ye. Markova did not hide the fact that in the method for making requests for progressive equipment there is much formalism and disagreement between consumers and manufacturers. The production plan for new forge-press and automatic machines frequently does not correspond to the actual needs for that equipment. The consumers order one item, suppliers demand another item and the manufacturers plan for the third item. This results in all kinds of misunderstandings.

"At times, we arbitrarily foist new machines and sets of machines on consumers," said M. Fedorov. "But they cannot always take them. If the reequipment plan of the enterprise does not include one or other equipment, the bank will not provide credit for it."

Comrades from the Gosstab are somewhat cunning in removing responsibility from themselves. The general order to machine tool builders for the output of metal-working equipment is formed on the basis of the total requests received from locations and departments. Very frequently, they contain traditional

machine tools. The consumer does not know about other new equipment. In the product list sent out by the "Soyuzglavstankoinstrument" to locations, new progressive equipment (for example, for cold extrusion, presses for powder metallurgy, etc.) are simply not there. Very few catalogues, brochures, price lists and other informational materials are issued.

After Three Years

Many times in the last few years, our newspapers have raised the question of improving the structure of the machine tool pool by developing progressive types of machines and equipment. Three years ago, the editor received a reply to the article "From machine tool to an automatic machine" from M. Cheburakov, Deputy Minister of the Machine Tool and Tool Industry. Yes, he admitted, in the 10th Five-Year Plan period the increase in the output of forge-press equipment was insufficiently ahead of the increase in the output of metal-cutting equipment. "But, he said, "in the 11th Five-Year Plan period, the situation will change radically, a 'green light' will be given to innovations of technical progress." L. Snovskiy, chief of the USSR Gosplan Machine Building Department spoke the same way in an interview with the "EKO" Journal.

Three years of the five-year plan period have passed. Did we succeed in achieving a sharp turning point in the structure of machine tool building? Speaking at the December Session of the USSR Supreme Soviet, B. V. Bal'mont, Minister of the Machine Tool and Tool Industry, reported that the plan for the past year on product output was overfulfilled, that the development rate of the sector as compared to the two previous years increased. All this is so. But it is also true that, so far, the machine tool builders have not achieved the level that would insure meeting the goals of the five-year plan. We recall that the problem was to increase the renovation rate of the machine tool park by 1.5 to 2 times. But such a goal was not set even for this year. A. P. Vasil'yev, Deputy Minister of the Machine Tool and Tool Industry, and B. F. Zakharov, chief of the USSR Gosplan subdepartment cited many explanations regarding this situation. But no matter how logical the arguments sounded, they cannot serve as justification.

The basic cause for the slowness in modernizing machine tool building is the shortage of production capacities, including also the output of forge-press equipment. Capital investments in the development of the sector and, primarily, in the production of the most progressive types of machines, are being assimilated extremely unsatisfactorily.

The Ministry of the Machine Tool and Tool Building Industry was unable to manage efficiently the money allotted generously by the state. The plans for introducing new production facilities and shops are disrupted year after year in many machine tool building enterprises. The staff of the sector was not able to organize cooperation with contract ministries and local organs for the purpose of accelerating construction installation work. Subdivisions of the Ministry of Heavy and Transport Machine Building, the Ministry of Construction, and USSR Ministry of Industrial Construction are lagging greatly in their work at the Sal'sk, Ruzayevsk and Ryazan enterprises of forge-press equipment.

At the December (1983) Plenary Session of the CPSU Central Committee, it was stressed that it is important to combine the increase in the shift coefficient with the energetic automation of production. The accelerated scientific technological development of the machine tool and tool industry is one of the main conditions for increasing the efficiency of the entire machine tool building production. Therefore, more energetic action against setbacks in outdated technical strategy is, in our opinion, the key economic problem.

2291

CSO: 1823/108

INDUSTRY PLANNING AND ECONOMICS

ENGINEER AIRS FRUSTRATION OVER PAY, PAPERWORK, TRADE POLICIES

Moscow IZVESTIYA in Russian 5 Dec 83 p 2

[Interview with Vladimir Pavlovich Kabaidze, general director of the Ivanovsk Machinebuilding Association by B. Kononov: "From Each According to His Talent," date and place not specified]

[Text] Vladimir Pavlovich Kabaidze, without missing a step, climbed the ladder from a common engineer to the general director of a large enterprise which develops the most modern machine tools of the "machining center" type and, on the average for a year, completes a full cycle -- from the concept of a new machine to the output of a series produced specimen. Recently a group of the Ivanovsk Machine Building Association, including the general director were winners of the state bonus. In the talk with V. P. Kabaidze we continued the "round table" theme of IZVESTIYA -- "The Engineer Must be a Creator."

[Question] Vladimir Pavlovich, how do you see the place of an engineer in today's society?

[Answer] There is at present a process of devaluating this title. When, in 1952, after graduating from the vuz, I went to work for a large Ryazan Machine Building Plant, each engineer was an important figure at the enterprise. This was an honorable, respected profession and engineers were occupied basically with creative work. Now we have many people with engineering degrees who occupy positions of supply men, economists and staff workers. Even in the purely production area there is now considerably more of them than in my youth. When I had occasions to visit similar machine building enterprises abroad, I was convinced that our trend is opposite to that of the world generally. We, regrettably, most frequently try to solve problems by a quantitative onslaught. Yet, often, one good engineering head is more valuable than 100 ordinary ones. Somehow we forgot this simple truth.

[Question] Do you think this is facilitated by the "wage leveling" of engineers and the lack of an interrelationship between the growth of the creative potential and the material compensation for work?

[Answer] Yes, the tendency to form an engineering corps "greater in number but lower in cost," is one of the most important reasons for the decline of prestige in the engineering profession. The salary of a very gifted engineer and of an average one differ only by about 25 percent. Engineers reach the "ceiling" salary very rapidly. Then the valuable worker usually transfers from the creative line to the administrative one. It is necessary to create a group or sector for him, i.e., increase the number of engineers. The growth along the administrative line intentionally or unintentionally knocks the engineer out of the number of creative engineers. He may remain a skilled specialist, but not a creator. More and more frequently still another way is selected -- becoming a worker. Family conditions frequently force an engineer to transfer to working on a machine tool which, although this does not require engineering skill, pays more.

There is a certain drain also to the scientific area where the possibilities for growing are considerably wider and skilled labor is paid better than at plants. As a result, we have many good scientific developments, but technology and industrial output "limp."

There is a great drain at present among creative engineers. If it is not stopped it will have an acute effect on the rates and scales of scientific technological progress. Creative work is now being stimulated in some sectors on an experimental basis, but this is done timidly.

[Question] In your opinion, what should be done?

[Answer] Essentially it is necessary to increase the rewards for the final results. In fact, at present, they often pay for paper work and not for the finished product. A designer designs a machine and gets a bonus. Make a prototype -- get a bonus. Produce a trial lot -- get a bonus. You look around, but you do not find the machine tool in series production. This means that actually all bonuses were paid for nothing. Yes, people worked, but the final result is zero. Time and resources of designers and production workers are lost. Therefore, in my opinion, bonuses should be paid only for what actually went to the national economy. This award should be considerable -- five to six times the salary. It should not be given generally but to those who develop the best machine. Thus, the creative workers and the national economy would be the gainers.

At present we have a paradoxical situation: you work better than others but receive less. We prepared very interesting tables for several plants in our "Soyuztyazhstanko" Main Administration. Last year the increase in our trade output was 14 percent, while this year it was 18 percent and, in the sector as a whole -- 6 to 7 percent. There are enterprises which reduce production volume. Yet, for the same number of workers, their wage fund increases considerably more than ours.

You look around and see that some enterprises fulfilled the plan by 101 to 105 percent. But right beside it is another column: as compared to last year -- the plan was fulfilled by 95 percent. This means that the plan was corrected. We fulfilled the plan for the three years of the five-year plan without

corrections at the start of November. But we reaped no benefits as compared to those who had their plan reduced.

The newest products, five years old, competitive in the west, make up 85 percent of our output, but in one of our plants -- they make up only one-and-one-half percent. Yet it received a higher award for the output of new equipment!

This is absurd. The volume of output is reduced, outdated products are produced, yet this enterprise prospers. They justify it by saying that the collective is not at fault and had past merits. In other words, the ministry is knowingly averaging privileges and awards for work. In my opinion, such averaging is only demoralizing. If output drops, its competitiveness level drops -- everyone from the director down to the watchman should feel this morally and materially. And, conversely, if things go well, everyone should also feel this rapidly.

[Question] Do you think that now a creatively active engineer should be placed in considerably better conditions than an ordinary one, and a leading collective should receive many more advantages than average ones?

[Answer] Absolutely. This would facilitate the rapid promotion of creative people and creative collectives. In fact, a creative person can do nothing in a collective that has "driven" old products for decades.

Of course, man does not live by bread alone. The pull toward creativity, the feeling of one's usefulness and debt to society are more important to many than material incentives. There is no question that it is very important to improve the salary system for engineers and to arrange it so that creative growth is accompanied by corresponding rewards. But, in my opinion, high goals, hard work in which one can demonstrate his abilities are still more important in forming a creator. A talented person is recognized when there is a rapid change in the created equipment, where problems become more complex.

Therefore, it is necessary primarily to stimulate collectives that take this path and provide an undeviating increase in the level of their output. One of the main indicators today, in my opinion, must be the work for export. This compels the entire collective to devote great attention to quality. One cannot win the market with unreliable machine tools. Bonuses are now given for export work. But there is no differentiation with respect to the destination of the exports. There should be a gradation -- socialist states, developed capitalist countries and developing countries. At present, when exporting to capitalist countries, enterprises receive nothing but illusory prestige and, therefore, actually the export of machine tools at those enterprises is not stimulated. Yet it should be so arranged that the enterprise, when exporting to CEMA countries, receive a considerable percentage and can purchase, for the earned foreign exchange, the machines it needs for its own development. The enterprise that operates efficiently should also develop faster.

This should be the result not only of receiving foreign exchange, but also of receiving domestic equipment, and the allotment of money for construction and modernization. We analyzed this in the plants of our main administration

starting in 1970 and were convinced that the yield of our enterprise is higher than that of all others (the commercial output increased 3.5-fold), while the investments were lower than those of the other enterprises. It is not necessary to be an economic genius to understand that we will not get far with such a capital investment policy. In my opinion, if an enterprise receives, it must guarantee an increase in output at least by that sum. Now everybody says "give," but they do not care about giving back.

[Question] Let us return, however, to our basic subject. Is not the engineer overloaded now by routine work and paperwork?

[Answer] Colossally. Take specifications for manufacturing some part. This, as a rule, is a ledger of 60 pages. It is assumed that the worker does not know a thing and that he must be given detailed instructions on how he should act on all intermediate operations. In Sweden, I saw that such a specification consists of only one page. The worker is told what he should do, but how -- he should know himself. He is given work according to his skill.

How many approvals must be gathered for each machine tool? Over 100! In my opinion, only one is needed -- that of the customer. For universal equipment only the responsible signature of the ministry should be needed. And that is all.

[Question] What attracted your attention more than anything else in the decree of the CPSU Central Committee and the USSR Council of Ministers "On measures for accelerating scientific technological progress in the national economy?"

[Answer] The possibility of officially creating temporary collectives. We practiced that before but, as the saying goes, at our own risk. Thus, in March of this year we called a meeting and posed the problem: develop high precision machining centers on the basis of IR-500 series produced machine tools. Until now we imported such machine tools from Switzerland. We decided to displace them in our internal market. Competitive machine tools were developed in two months! Of course, this was a very difficult amount of work for the temporary collective of designers, technologists and workers. At first, everybody said: it is necessary to change the design radically. Then, however, a decision was made to reduce tolerances of all parts to an eighth or a tenth and make the machine tool highly precise. If it is taken into account that even without that the standards used in making the basic machine tool were more rigid by about 40 percent than the existing GOST, you can imagine how complex a problem it was necessary to solve. Even one very talented person could not have done it. In fact, it was necessary to pass through the whole technological chain and look for possibilities for improvement everywhere.

We now have the experience of an interdepartmental temporary collective. We joined our efforts to the Cybernetics Institute of the UkSSR Academy of Sciences to develop a large flexibly automated production facility at one of the machine tool building enterprises. In January of this year, as diplomats say, the first meeting was held between the high negotiating sides, while in January of next year the system will be placed in operation. This is possible only because an informal collective of specialists works in its own field. There were

no walls or departmental barriers between the cybernetic people, machine tool builders and machinebuilders. We worked as a single coordinated mechanism and were joined primarily because everyone believed in the creative potential of his partners. This was started not by an order from the top , but on our own initiative.

Temporary collectives are also good in that they make it possible for young people to advance rapidly. We introduced a new position, "chief project designer" and appointed a promising engineer to it. He, of course, gets additional compensation for the responsibility and coordination of the work with the customer. But the main thing is the high goal. Such a temporary collective at our place, for example, is now implementing the design of an automated flexible production facility for diesel engines for the Moscow Automobile Plant. This is of great importance to the national economy and is being done basically by young and able designers. We think that for us a continuous change in products and tight schedules for producing new machine tools is the main road in developing the collective and forming creative engineers.

2291

CSO: 1823/112

INDUSTRY PLANNING AND ECONOMICS

RESULTS OF EXPERIMENT WITH MANAGEMENT, PRODUCTION OF PIPELINE MACHINERY

Moscow PRAVDA in Russian 16 Jan 84 p 2

[Article by G. Yastrebtsov: "Extensive Exploration" (Elektrostal', Moscow Oblast)]

[Text] Ten years ago in Pervoural'sk, one could hear how complimentary the piperollers were about the "30-102" mill, made at the Heavy Machine Building Plant at Elektrostal', a city near Moscow. The praise of the Ural metallurgists was entirely merited since the productivity of the machine was triple that of specimens abroad.

We also visited other metallurgical enterprises where equipment made by the Elektrostal' people was installed. The "104" mill at the Nizhnedneprovsk Pipe Rolling Plant produced seamless pipe a third greater than similar machines, while in Taganrog the "6-25" pipe-welding mill converts narrow metallic strips automatically into a pipe with a speed double that of the best mills abroad.

The Elektrostal' workers will not give up their hard-won positions. One example is the development and industrial introduction of the technology and a set of machines for the manufacturing of efficient petroleum-gas pipe up to 530 millimeters in diameter. The "Elektrostal'tyazhmash" Association, as the head enterprise, designed and manufactured a machine for the electric welding of pipe now installed at the Vysunsk Metallurgical Plant. In this work, awarded the USSR State Bonus for 1983, a number of large institutes participated. For the first time in the practice of metallurgical machine-building the State Emblem of Quality was awarded to the entire equipment complex and, incidentally, also to its product-pipe.

The "Elektrostal'tyazhmash" designers also designed for their own needs a powerful, fully automated mill for hot cross-helical rolling, that has no equal in world practice. In the three years of the present five-year plan period, a total of over 30 specimens of highly efficient equipment were created in the association.

Precisely, such equipment is needed today that is not only equal to the best abroad, but even exceeds it and is capable of satisfying fully the needs of the national economy, and compete successfully in the world market.

So far, there is not enough of such equipment. Why? We will try to analyze the problem using the example of the "Elektrostal'tyazhmash" Association, which joined with a number of other enterprises in the country in a large scale experiment, whose essence is briefly: independence and responsibility.

With extensive fighting exploration, the experiment we can, perhaps, win this economic battle. To get in front of the others, to try out on oneself working, in a new way, so that later, in the 12th Five-Year Plan period, it would be easier for those that follow, this is the practical goal of the participants in the experiment. It has only just begun and, of course, so far it is too early to speak of results. But labor collectives have been preparing for it for a long time and thoroughly, and in the course of this preparation many problems and many contradictions arose on whose solution the success of the new pursuit depends.

Let us listen to the voices of the Elektrostal' people.

N. Kechin, brigade leader of turning and boring mill operators:

"As far back as October of last year, when the conditions of the impending experiment were published, we began to study them intensively. Of special interest was the condition that in the annual plan for the association, a product sales volume indicator would be set taking into account the fulfillment of obligations on deliveries according to concluded contracts. Each shop worker knows that our products are awaited in many cities of the Soviet Union and abroad. This means that the personal responsibility of the worker for the entrusted job is very great. We had a meeting of the brigade and decided to work so that productivity was the highest and costs minimal. And, of course, we want to do everything for the absolute fulfillment of contracts."

"It must be said that the shop participates actively in outside cooperation, as well as did our brigade. We do the finishing machining of parts for liquid friction bearings. The brigade works well -- the production target for last year was reached by 1 November."

V. Khizov, partkom secretary of the association:

"Collectives, like N. Kechin's brigade, are our gold fund, our support. Here, say, is a comprehensive-shift brigade imeni 26th party congress, headed by Communist A. Kryukov. The brigade works in the gear coupling section. It works regularly and with high quality, exceeding plan tasks month after month. I could name other working collectives, for example, Ye. Aulov's brigade of model-makers. The brigade leader in the association's partkom member, an excellent specialist and instructor. We are now very much involved in improving the brigade form of labor and we see that this is promising and useful. As a rule, brigades have better work discipline, less tardiness and production scrap, and the wages are higher."

"However, it is simple to call for the creation of brigades, but it is much harder to achieve their stable, regular work. Without that, brigades are a pure formality."

"There appears to be a paradox: the association produces excellent metallurgical equipment, while in the shops at times one sees a lack of organization and crash work. Intermediate product production lags chronically, the organization of work positions requires extensive improvement and labor discipline limps along. Cases of unauthorized absences became more frequent."

"Everything is far from right with the organization of brigades. There are too few of them in some places and the people in them are not tied by common interests. Under the conditions of the economic experiment which specifies changes in the planning indicators and bonuses to workers, weak brigades will not be comfortable."

S. Gavrisev, turner, candidate for membership to the CPSU local committee"

"The brigade is a good school for uniting a collective. Of course, we have in mind a real, strong brigade. Otherwise, the people will hardly be successful in their work or in creating a good moral climate. I can cite many examples of the positive effect of a collective on discipline infringers. But there are also some workers that administrations and social organizations can do nothing with, then the trouble-maker resigns voluntarily. Then he moves to an adjacent plant and there everything is repeated again. It is time to place a barrier against such 'rolling stones'."

"As is well known, the general situation in production has a direct effect on labor discipline. Frequently, it happens that a worker comes to the shift and there are no intermediate products. Sometimes, we stand idle for an hour or more. It happens that the first two 10-day periods in the month we work listlessly, but at the end of the month, we do rush work. This is not always the fault of the plant, but that does not make it easier."

"It is necessary that the plant have a considerably better supply of rolled stock. Then there will be no interruptions due to the lack of intermediate products and no rush work. Everything must be accurately placed in the proper places in the course of the experiment."

Ye. Petrov, chief of the economic planning department:

"The experiment being started is a practical check of how enterprises will be able to manage the new rights in planning and economic activity. This is one side. The other side assumes the strengthening of our social and individual responsibility for work results. The conclusion from here is: the central problem is to achieve a combination of cost accounting independence and personal responsibility of labor collectives."

"As applied to our association, this means, first of all, high efficiency of production, maximum economy of labor and material resources, absolute fulfillment of contracts and delivery schedules. Now there is set up a direct relationship as follows: the delivery plan is fulfilled, especially on contracts, the material incentive fund is increased by 15 percent. If not -- three percent of the fund is lost for each unfulfilled percent."

"What has already been done? Our 1984 plan for the "Soyuzmetallurgmash" All Union Production Association was finally approved. We, in our turn, issued a plan to the shops for the first quarter on volumes and the list of products. About 800 contracts on equipment products were formalized. This is 97 percent of the total volume, including 20 percent of the plan which we formalized on direct, long-term contracts. With customers, we coordinated quarterly equipment delivery schedules for the majority of high priority facilities, we sent to the shops tasks on increasing the productivity of labor and reducing production cost..."

M. Grinshpun, chief designer:

"In recent years, the efficiency of the machines we designed increased; in 1983 designs were developed for new rolling and pipe mills whose introduction will mean 25 million rubles to the national economy. What do we think will this be due to?"

"First, due to saving metal. Because of new in principle design solutions, and the use of new technological processes on our machines, we will produce efficient types of pipe. By using tubular intermediate products alone, rolled in our transverse rolling mills and maximally approximated to the shape of finished products, we will save 900 tons of metal annually. Equipment we designed for thermal treatment will make it possible for metallurgists to produce pipe of higher strength and reduce the thickness of the pipe walls, i.e., again will save a considerable amount of metal."

"Secondly, higher unit capacities of the machines will have a considerable effect. Double-thread cold rolling pipe mills created by the association have an output 3 to 4 times greater than their predecessors and weigh only 1.5 to 2 times more. The advantage is obvious."

"Regrettably, the effect on the national economy obtained by our customers, reflects very little on the work indicators of our association."

"It is also necessary to mention that raising the efficiency of the created equipment and the acceleration rate of the scientific technological progress depend greatly on how efficiently the ministry proposes to take measures on strengthening our design and technological services, as well as on the accelerated development of the technological possibilities of the enterprise."

Ye. Smelov, general director:

"Our association has a unique production feature. Repeat products make up less than a tenth of the total volume. This, of course, must be taken into account in the system of planning and material and technical supply. So that the collective can work normally without interference, the list of products and machines must be approved at least two years ahead. Actually, however, we receive the list when the machine has to 'go.' Moreover, there are all kinds of changes. Even for 1984, the year that the experiment starts, we received the preliminary plan very late -- in June. This disturbs the collective and deprives it of confidence in regular, clear-cut work."

"We hope that the experiment will make it possible to do the job efficiently. In fact, its conditions envisage the development and approval, in the five-year plans of precisely the list of equipment with a long production cycle, with instructions for specific equipment."

"Now, about indicators. I think that for such associations as ours, the basic indicator should be the economic efficiency of the produced equipment or, speaking more precisely, the national economic effect obtained by the customer when assimilating our machines. On the basis of substantiated forecasts, it is possible to set for the association the state task on reaching a certain level of the indicated effect, which must become the basic criterion for evaluating the work of the enterprise along with the fulfillment of contractual obligations. This, strictly speaking, is what we are trying for. This for us is the final result."

"We also hope that under conditions of the economic experience, all problems of balancing the production plans and, especially, of the material and equipment supply will be solved."

Thus, the Elektrostal machinebuilders, as well as other labor collectives of five ministries, began a large-scale economic experiment. They are prospectors on a difficult and unexplored path. They will have to rebuild on the go, because little time was given them -- the 12th Five-Year Plan period is not beyond the mountains."

2291

CSO: 1823/110

INDUSTRY PLANNING AND ECONOMICS

RETRAINING OPPORTUNITIES FOR NC MACHINE OPERATORS, PROGRAMMERS

Moscow GUDOK in Russian 14 Feb 84 p 3

[Article by Ye. Maliota: "First Product" (Astrakhan)]

[Text] In the office of plant engineer Viktor Nikolayevich Korpusev, there is a mirror-finish D62 piston on a bookshelf. The tablet on it states: "Machined on a machine tool with numerical control. Program composed by engineer technologist N. Mel'nikova."

At the start of last year, six machine tools with numerical control were received at the Astrakhan TRZ [Diesel Locomotive Plant]. There were no daredevils to deal with them at the time: knowledge of electronics, automation and programming were needed... Engineer V. Korpusev heard about the innovation, a man with a head full of radio and electric circuits, as people said about him in fun. He could not resist the temptation to study the new machine tools.

He spent many evenings with S. A. Mel'nikov, chief of the plant, talking about how to start up the new equipment. Finally, they reached a conclusion: it is necessary to create a design technological bureau to service the machine tools with numerical control. It was headed by V. Korpusev. It was staffed with young specialists and workers who still had not been made wiser by production experience.

When the new equipment began to be installed in the tool shop (no other place was found at the plant) universal lathe operators spoke about them skeptically: "if a 10-grader can work on it, it will be impossible to achieve the precision and finish of machined parts."

But something entirely different happened. Captiously, the lathe operators checked the pistons and shafts machined by Serezha Pisarenko, who studied in the 11th grade at night school. And they were surprised. A. V. Korpusev, programming engineers, man and wife, Valeriy and Natal'ya Melnikov and adjusters R. Gogorev and A. Kharin were happy. A section of three domestic and three Polish machine tools began producing. And they did everything themselves without prompting from the outside. V. Korpusev took the piston to his office as a reminder of that first product.

The present chief of the bureau for servicing machine tools with numerical control, R. Gogorev, acquainting me with the section, stated "So far, we assimilated the output of 16 different parts, but this is not the end. Already this year, the section will produce an output to an amount of 200,000 rubles. We will make this a cost accounting section. In two-three months, we will train operators from among high school graduates. We will introduce multitool servicing..."

This section is only the beginning. The future of all the machining in the plant is in its development. In modernizing the plant, it is envisaged to put in operation, first, a new shop equipped with modern machine tools with numerical control and automated and mechanized flow lines. This shop will begin producing high quality parts not only to meet the needs of the plant, but also for other enterprises. It will have fewer machine tool operators than at present.

2291

CSO: 1823/115

INDUSTRY PLANNING AND ECONOMICS

COMPUTERIZED PROCUREMENT, PRODUCTION, INVENTORY CONTROL AT UKRAINIAN PLANT

Kiev RABOCHAYA GAZETA in Russian 4 Oct 83 p 2

[Article by A. Chepelev, deputy general director for economic questions, "Novokramatorsk Machinebuilding Plant" Production Association; and A. Korin, an engineer-economist with the association: "Lessons in Economic Thought. The Computer Does the Planning."]

[Text] Kramatorsk, Donetsk Oblast. The "Novokramatorsk Machine Building Plant" Production Association imeni V. I. Lenin is one of the few associations whose activity determines the technical level of the economy's basic branches. Its products are truly unique. Rolling mills, heavy presses, walking and wheel-type excavators, gigantic ore crushers, multiple-cable underground mining machinery--such is thee by no means complete list of equipment produced by the Kramatorsk machine builders.

Not even Uralmash [the Ural Heavy Machine Building Plant imeni Sergo Ordzhonikidze] can compare with the Novokramatorsk Machine Building Plant in production volume. Suffice it to say that it produces more than a million different parts for the machinery it manufactures. Given such a scale, the improvement of planning and management acquires paramount importance especially in the present stage, at a time when the task is to increase the volume of production without increasing human, raw material and fuel-energy resources.

Nonetheless the volume of routine paperwork associated with the management and planning of production at the "plant-shop" level has remained very considerable. As a rule, this work is performed manually by people with higher technical education even though it would require a remarkable imagination to call filling out forms and blanks engineering work.

All this happens because the system of intraplanning of production has remained virtually the same as it was in the 1930's. But it is virtually impossible to perform manual calculations of the shops' production targets for various groups of equipment and the cycle of duration of the production of each items on the scale of our enterprise since hundreds of millions of arithmetical operations are involved. This would require increasing the administration from five to at least thirty thousand people. So it is that all administrative work has been performed on a so-called experimental basis using the preceding year's data. At the same time, neither the reception of contracts, nor the schedule for delivering the finished

product nor the preparation of technical documents have been accompanied by current monitoring of equipment utilization. A disproportion developed: some groups of machine tools, let us say turret lathes, have been overloaded while others have stood idle. The next year, the situation was reversed. But in both cases, the shortcomings in planning have had a negative impact on the rhythm of production.

Or the endless operations that have long ago become the talk of the town. How much time these operations cost engineers, technologists, shop and sector chiefs, and other specialists! The reason is the same: in the existing system of intraplant planning, it has been impossible to organize effective and reliable monitoring of intershop cooperation, the development of standard hourly operating times of machine tools, the proper filling of orders by blanking shops, etc.

It has been extremely difficult to form and keep the plant's portfolio of orders: each year Novokramatorsk Machine Building Plant concludes approximately 1200 contracts for the production and delivery of more than 500 types of products. No one had a clear understanding of the types and quantities of materials that would be needed in the following year. Orders were placed on the basis of the previous year rather than on a year by year basis.

It was all these difficulties that necessitated the development of an integrated system for improving planning and for transferring all calculations to computer. With the advent of third generation computers with a combined capacity of up to 550,000 operations a second, a large detachment of postanovshchiki, programmers and elektronshchiki also became possible.

The initial problem was to convert all nuances of intraplant planning to the rigorous language of mathematical logic and this required finding the specific basis for the management process proper, a kind of universal unit of measurement.

Design and production documentation for items that under the terms of the contract are bartered as finished products became such a basis which was common to all planning calculations. This documentation contains complete information regarding all standard costs required for the production of a given product, the address of the producer (the shop or sector) and the equipment involved.

We have called goods that have the right to be bartered separately commodity units. They formed that basis for the compilation of plans. The sum of the total list of commodity units in wholesale prices are now the enterprise's plan for commodity output, while the sum of their calculated production cost is now the normative enterprise cost of production. The plant has also drafted and ratified the commodity unity principle.

While the quantity of administrative documentation has naturally increased, it is now processed by computer!

The creation of the normative base is the most complex and important feature in the introduction of the system and the substantiation of the plans depends on the quality of the norms used in the calculations. The difficulty is as follows. As a rule, the development of technical documentation on products the enterprise is scheduled to produce is completed in the first quarter of the operational years. However the draft of the plan is calculated 12 months earlier, i. e., at a time when blue prints and flowcharts are essentially nonexistent. This gap does not present a problem to enterprises that produce in series. It is another matter where machine building plants like our is concerned.

But there is a way out. For example, we and the designers jointly analyzed one-year commodity unit plans for repetitiveness. It was found that even at our enterprise, approximately 40 percent of the annual volume of production consists of a stable mix of excavators, mills, presses and rolls. The archives contain technical documentation developed on them in the past. And consequently, they also contain actual norms governing the expenditure of raw materials, power, supplies, labor and other resources. Each repeating item has been assigned a code. Normative production costs are entered on punch cards and magnetic tape.

With the creation of analagous norms on nonrepetitive items, the situation became considerably more complex. It was necessary to use an average indicator for all outlays in order to calculate them. Separate instructions were created for calculating norms for assemblies used in rolling equipment. After all, this is the most complex, labor-intensive feature at our plant and absorbs up to 50 percent of all machine tool time. What is more, its mix changes every year and this complicates the work load of various groups of plant equipment. Our approximate method which excludes gross errors: calculations based on analogues that the designers establish for every equipment assembly scheduled for production.

Such in brief is the general part of the integrated system for improving planning. Based on commodity units, the computer easily and above all without errors and using optimal parameters calculates the actual resources of the plant and shops and determines the enterprise's requirement and potential for fulfilling orders based on contracts.

The use of the commodity unit as the basic element in calculating the plan for shops makes it possible to monitor the state of orders for the entire list in the one-year plan. The computer can at any time provide information on the volume of overall production, on the use of shop capacities, can enumerate orders that were completely filled in the current month.

The portfolio of orders is also fed into the computer both for types of products and for various periods of time. Accordingly, we obtain data on goods shipped for any past period--month, quarter or year. The computer can supply information on the state of fulfillment of any order. It can give a full breakdown on what must be done by whom and when so that a product can be shipped to the customer.

It would be no exaggeration to say that the integrated system for improving planning fulfills the age-old dream of enterprise management at all levels: to be able to continuously monitor capacity utilization as contracts are concluded. And this is the basis for making any enterprise's realistic. The introduction of the system helps to improve the quality of management. Engineers in the various departments continue to exercise their decision making function on the basis of incoming data. Higher demands are made on the administrative staff. There is less of a need for employees who are listed as engineers but who essentially perform work that has nothing in common with real engineering.

Here is one more positive point. It is no secret that costly computers have become "golden" calculators at many plants where they are used to perform the elementary problem of calculating wages, pensions and bonuses even though in the reports this has all the appearance of an ASU. The mastery of the integrated system for improving planning, however, opens up the possibility of using computers with an appreciable effect in production even if they are not used to full capacity.

5013

CSO: 1823/74

INDUSTRY PLANNING AND ECONOMICS

UNIFICATION OF DESIGN SPECS, STANDARDS URGED

Moscow EKONOMICHESKAYA GAZETA in Russian No 35, Aug 83 p 6

[Article by economist A. Fomin: "Standardization and Norms"]

[Text] The standardization of items and the typification of technological processes are one way of reducing expenditures on design work and improving their effectiveness. In fact, a good choice by a designer of an existing progressive subassembly or part reduces planning-design time. But there are several difficulties.

The fact is that borrowed documentation is paid for in considerably lower amounts than new. The list of prices for planning-design work evaluates the use of previously developed documentation in different ways. For example, point 3, section 2 of the Ministry of Machine Tool and Tool Building Industry's "Price List for Planning-Design Work on Nonstandardized Equipment" establishes that, "when plans or individual blueprints for nonstandardized equipment are reused unchanged, the cost is determined using a coefficient of 0.15 for the prices of the technical plan and 0.2 for the prices of the blueprints," but the "Price List for Design, Special Planning-Design and Technological-Planning Work Done By Organizations and Enterprises of the USSR Ministry of Power and Electrification" states that "when design documentation for machines, machinery, equipment, and so on, is reused unchanged, the cost of that documentation is set at prices in this list, minus 20 percent." But when changes are made in blueprints, their cost is set at prices in that list plus up to 60 percent, to be determined by the implementing organization (enterprise).

Setting the cost of borrowed documentation so low leads to a situation in which the designer does not use previously developed documentation or uses it with insignificant changes and draws it up as newly developed.

At the same time, only the holder of the original documentation can make changes in a design. Therefore, insubstantial changes made by a designer in the course of working on a new item using previously developed documentation (replacing fasteners in an assembly drawing, changing the surface smoothness of a part on a drawing) without changes in the original lead to a situation in which the blueprints used cannot legally be considered borrowed, and the reduction coefficient cannot legally be applied to them.

There is thus no incentive for standardization, especially in the ministries operating with the indicated price lists. In this connection, it seems to us necessary to encourage the standardization effort at the planning-design stage by establishing rates for the use of previously developed documentation at the cost level of newly developed design documentation minus the cost of (copied) blueprints. This would achieve a significant impact on lowering design work labor intensiveness and improving the quality of the output produced through standardization.

11052

CSO: 1823/48

METAL-CUTTING AND METAL-FORMING MACHINE TOOLS

UDC 621.952.3

TECHNICAL PARTICULARS OF NEW MULTI-SPINDLE VERTICAL BORING MILL FEATURED

Moscow STROITEL'NYYE I DOROZHNYYE MASHINY in Russian No 12, Dec 83 pp 8-9

[Article by engineers Ye. A. Androychikov and L. V. Bader (VKTISTROYDORMASH):
"Multi-Spindle Vertical Boring Machine Tool"]

[Text] The VKTISTROYDORMASH [expansion unknown] developed a vertical boring multispindle machine tool (see Figure), whose special features are a hydraulic feed drive along the vertical of the table with respect to the machined part and the absence of a gear box in the main drive.

The machine tool consists of a welded base with a reservoir for the lubricating-cooling liquid; a stand on which are mounted an electric cabinet, a hydraulic tank and a hydraulic feed control panel; an upper frame that serves to fasten the multi-spindle drilling head, with a jig plate hung on rods, as well as to mount a reducer motor for the main drive; a feed table on which are placed the feed hydraulic cylinder and four guide rods; a fixture for the machined part; a support; and a control panel located on a bracket.

The fixture used when machining intermediate products for especially large frame parts (weighing over 100kg) is made in the shape of a carriage, designed to transfer the intermediate products from the loading zone to the work position. The carriage, whose initial position is in the loading zone, is moved to the machining zone by a hydraulic cylinder along the guides for a distance of up to 1200mm. The movement is executed with braking for which purpose throttles are used. The carriage has spring wheel suspension which provides for the fit of the part during drilling under the action of the forces of the drills on rigid supports; when drilling is completed, the spring components of the suspension come back to their initial shape, the carriage is lifted above the rigid supports and can be rolled to the loading zone.

Setting fingers are used for basing intermediate products and are mounted on the upper plate of the fixture.

To prevent wedging and tool breaking during the drilling of intermediate products, the machine tool is equipped with a support with a pneumatic cylinder.

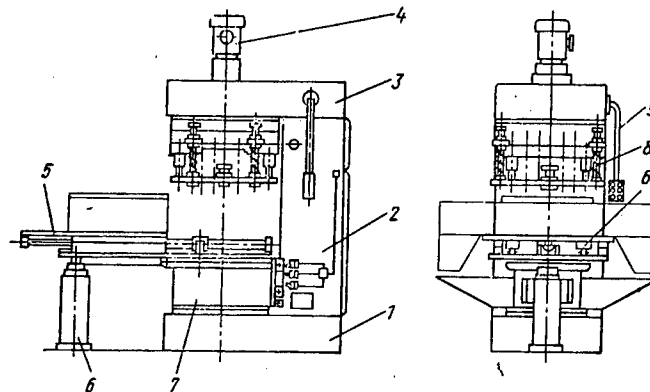

Figure. Special multi-spindle vertical drilling machine tool:

1 -- base; 2 -- stand; 3 -- upper frame; 4 -- reducer motor; 5 -- set-up fixture; 6 -- support; 7 -- feed table; 8 -- jig plate; 9 -- control panel.

Specializing the machine tool for drilling one or several parts close in size made it possible to simplify the main drive by using a planetary reducer motor whose output shaft is connected directly to the driving shaft of the multi-spindle drilling head. The necessary rotation speed of the spindle is obtained by selecting the gear ratio of the reducer motor and the gear wheel and pinion of the multi-spindle head.

The hydraulic table feed, consisting of an electric motor, distributing reducer, a pump for accelerated movements and a working feed pump, a hydraulic panel for feed and actuating cylinder, provides for accelerated table feed, one working approach and an accelerated withdrawal in a semiautomatic mode. The drive makes it possible to regulate speeds and feed forces in a wide range.

The maximum feed force is 125 kilonewtons which makes it possible to drill a large number of holes and eliminates the danger of breaking drills. The absence of a gear box increases the reliability of the machine tool. The stationary attachment of the multi-spindle head with respect to the frame simplified the design and increased its rigidity.

In adjusting the machine tool for drilling a new part; it is necessary to replace the multi-spindle head and the fixture and to adjust three cams that control the end switches of the feed drive, to new values of the table strokes.

The machine tool operation in the semiautomatic mode and the presence of the set-up fixture in the form of a carriage increases productivity as compared to similar work on universal machine tools by 3 to 5 times and is convenient for servicing the machine tool.

Machine tool specification

| | |
|----------------------------------|-------|
| Largest drilling diameter, mm | 17 |
| Number of holes, | 20 |
| Maximum feed force, kilonewtons | 125 |
| Feed range, mm | 5-365 |
| Maximum table stroke, mm | 320 |
| Dimensions of table feed, meters | |
| length | 3.66 |
| width | 2.6 |
| height | 3.7 |
| Weight of machine tool, tons | 9 |

The machine tool was introduced at the Drogobychsk Automobile Crane Plant. Introduction of one machine tool saves 25,000 rubles per year.

COPYRIGHT: Izdatel'stvo "Masinostroyeniye", "Stroitel'nyye i dorozhnyye mashiny", 1983.

2291

CSO: 1823/123

METAL-CUTTING AND METAL-FORMING MACHINE TOOLS

CNC DRILLING-COUNTERBORING MACHINE FOR PCB PRODUCTION INTRODUCED

Moscow EKONOMICHESKAYA GAZETA in Russian No 1, Jan 84 p 19

[Article: "Odessa Milling Machine Plant imeni S. M. Kirov Offers the Specialized OF-99F2 Drilling-Counterboring Machine (to replace the OF-72B)"]

[Text] The numerical programmed-control OF-99F2 is designed for drilling and reversible counterboring printing plates and for drilling plates without counterboring. It can machine one-sided, two-sided and multilayer printing plates to GOST 10317-79.

Basic technical data and specifications:

machine tool: precision class -- P; largest working zone -- 400 mm long by 200 (400) mm wide; largest blank -- 460 mm long by 220 (440) mm wide by 8 mm thick; max. and min. drillbit sizes -- 3.5 and 0.6 mm; greatest counterbore diameter -- 3.8 mm; number of spindles -- two; spindle rpm range (continuously variable) -- 4,000 - 23,000 min.⁻¹; maximum number of cycles per minute -- 85; precision of aperture axis coordinate size in a rectangular coordinate system -- 40 μm; dimensions -- 1,010 x 696 x 1,380 mm; weight -- 550 kg.

SP22-1M numerical programmed-control device: system type -- positional; number of coordinates being controlled simultaneously -- two.

Wholesale price -- 13,000 rubles.

Series industrial production to begin in early 1984.

Orders for 1984 and subsequent years should be sent through one's own ministry to the USSR Gosplan, Ministry of Machine Tool and Tool Building Industry and the "Soyuzglavstankoinstrument" (attached to the USSR Gosstab).

Manufacturer's address: 270014, Odessa, ul. Kirov, 5.

[Photograph of unit on following page.]

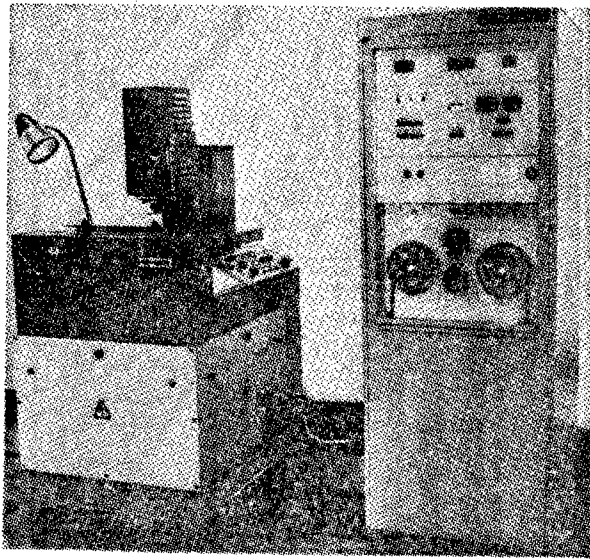

11052
CSO: 1823/86

OTHER METALWORKING EQUIPMENT

DESIGN, START-UP OF LARGE HOT ROLLING MILL DISCUSSED

Kiev RABOCHAYA GAZETA in Russian 28 Dec 83 p 3

[Article by A. Slobodyanik, engineer and V. Seleznev, correspondent: "With the First List!"]

[Text] This great event in the life of the country's metallurgists occurred on 27 December in the early morning hours. The special design thick-sheet "3000" rolling mill of the Metallurgical Plant imeni Il'ich was hot tested. Four red-hot slabs passed through all the technological operations from hydraulic scalebreaking to cutting the sheets. Now the rolling line is being finished.

Thus, the first stage of the all-union shock construction project on which a 10,000 member collective of builders and installers from many cities in the Ukraine worked was completed successfully. Here, in the Azov Steppe, the first cubic meters of concrete were poured in February 1979. Since then, at the construction site which personifies the power of modern industry and has become a memorable landmark in the biographies of thousands of people, there participated, besides the builders, labor collectives of dozens of design institutes and over 300 plants of all the union republics. Dozens of thousands of tons of basic technological equipment were received from Czechoslovakia.

"Today is a big holiday for all construction participants," stated S. P. Kuzenin, chief of the party staff of the construction site and second secretary of the Zhdanovsk party gorkom. "We kept our word to the Motherland! The mill began supplying wide-strip 8 to 25 mm thick and up to 24 meters long. Pipe for the northern petroleum and gas pipelines will be manufactured from this wide-strip of low-alloy structural steel brands.

The range of the construction site is amazing. The main building for the mill stretches for 1260 meters, while its width is 350 meters. Moreover, the complex contains dozens of very large facilities.

"The construction is rightfully a demonstration model," stated N. P. Shestak, chief of the "Zhdanovstroy" Combine. "Its special feature is, primarily, the use of modern technical methods and solutions. In particular, laying pre-fabricated foundations was introduced widely. This provided high quality of production, precise and increased rates of work. For the first time, there

was organized the conveyor method for installing block sections with all the power lines and pipelines in place. This innovation made it possible to reduce construction time by nine months. Finally, the start-to-finish brigade contract became the efficient accelerator.

With regard to this, here is the opinion of A. P. Rytov, installer of the "TETstroy" Construction Administration of the "Zhdanovmetallurgstroy" Trust:

"The first start-to-finish contract by one brigade was concluded with mechanic-installers, electricians and sanitation workers when building the most complicated facility -- the scale sedimentation tank. This cooperation justified itself fully. The responsibility of related trades increased and the job was the gainer. We released all facilities ahead of schedule and with high evaluation."

Hundreds of brigades from the "Zhdanovmetallurgstroy," "Azovstalstroy," "Donbass-metallurgmontazh," "Donbasselektromontazh," "Koksokhimteplomontazh" trusts and the "Voroshilovgradkhimstroy" and the Krivbasstroy" combines distinguished themselves in building the rolling line, the heat-utilization electric power plant and the circulating water supply facility. Each day literally set records and identified the new names of labor leaders. Members of brigades of F. A. Shevchuk, V. T. Tarasov, V. S. Krupchenko, M. S. Bodashevskiy, D. F. Bakhov, G. I. Lebedenko and many, many others remember the joy when the all-union shock banner was raised in their honor to the playing of an orchestra.

Now the day, so important to the participants of the construction site, has arrived when the giant mill was released for operation. We asked F. V. Klafas, assistant chief of the automation shop, to tell us about the special features of the complex.

"Many of its facilities are of special design, starting with the heating ovens where the metal is heated to 1300 degrees," he said. "Heat emitted by the ovens is not lost, as in other mills, but is used to produce steam. The superheated steam is sent under high pressure to a turbogenerator which produces electric power. The mill is literally saturated with electronic monitoring and controlling systems which make it possible to regulate the rolling of the sheets under heavy modes and with rigid tolerances. For example, temperature variations of the metal must be within plus-minus 10 degrees. The eye of a very experienced specialist cannot notice the difference. Only an automatic system can be of assistance in this case. It will be tuned up in the next few months. Today we would like to thank the builders for their selfless, heroic and good work from the bottom of our hearts!"

2291

CSO: 1823/109

OTHER METALWORKING EQUIPMENT

MINSK KALIBR PLANT RETROFITS WITH CNC TO IMPROVE PCB PRODUCTION

Minsk SOVETSKAYA BELORUSSIYA in Russian 25 Feb 84 p 1

[Article by G. Lukavets, engineer technologist of the Minsk "Kalibr" Plant:
"In Creative Search"]

[Text] Several years ago, drilling printed circuit boards [PCB] was a complicated problem for many subdivisions of the plant. It was not only that drilling the boards on the usual drilling machine tools slowed down an increase in the productivity of labor, but the quality also suffered since many assembly shops complained about them.

A way out of this situation was found by changing this operation to drilling with machine tools with computer numerical control. However, immediately another problem arose -- it became necessary to prepare dozens of programs for drilling various types of boards. Members of the scientific technological society of the enterprise helped solve this problem.

As a result of studying information sources, V. I. Slaboder and V. V. Kuz'min, workers in the chief technologist's department, were able to develop and introduce at the enterprise control programs by using a small type "Chekan" computer for machine tools that drill the printed circuit boards. A. I. Starostenko, chief of the OASUP [Industrial Automated System of Production Control], and L. F. Lapushinskiy, engineer programmer of the department, were involved in this work. Over 200 programs for drilling various types of boards were developed by joint efforts. The results were noticed immediately -- the efficiency of production increased and the quality of board manufacture improved considerably. Over 13,000 rubles were saved by introducing this proposal.

At present the paint and plating shop contains a specialized section where there are five machine tools with computer numerical control. It is enough to say that at present 60 percent of all printed circuit boards are drilled here. In the fourth year of the five-year plan, it is planned to raise this indicator to 70 percent.

This is only one example of using in practice the achievements of science and technology and advanced experience.

It is precisely the searching for reserves in this direction that is the determining goal in the activity of primary NTO [Scientific Technological Society] organization, which numbers about 700 members. The plant NTO council is headed by Boris Vasil'yevich Kravchenko, chief engineer of the plant. Last year 48 innovations were introduced, including 36 that saved 70,400 rubles. Implementation of measures on new equipment made it possible to save over 70,000 people and free 250 people conditionally. In assembly production, the creative brigade headed by outstanding innovator, engineer designer of the O GK [Department of the Chief Engineer], Anatoliy Ivanovich Kostin, introduced a monitoring diagnostic system that makes it possible to raise the quality and reliability of devices considerably and improve working conditions.

2291

CSO: 1823/106

REASON FOR SLOW PROGRESS WITH INDUSTRIAL LASERS IN BELORUSSIA VIEWED

Minsk SOVETSKAYA BELORUSSIYA in Russian 8 Jan 84 p 1

[Article by V. Volkov, sector chief, and A. Zayats, group chief, at the Belorussian Scientific Research Institute of Scientific-Technical Information and Technical-Economic Research (BSSR Gosplan), under the heading "Work With Highest Productivity -- The Law Every Day: At the Highest Quality Standard": "Shops Need Lasers"]

[Text] Lasers are a recent item; the first laboratory devices were developed in the early 1960's. Today, laser equipment is being used successfully in many branches of the national economy, especially in electronics, medicine and communications equipment. It holds promise for use in industrial production technology such as automobile manufacturing and agricultural machinebuilding. This quite powerful light radiation can play a role in welding, in joining the most different metals, and can be truly an ideal "cutter," cutting any materials -- from fabrics to high-melt titanium and ceramics -- into the most complex shapes. Finally, laser surface heat-treating of metals is extremely promising.

...In the laser technology laboratory at the Minsk Automotive Plant. Physico-chemical research in laser heat-hardening processes has been conducted here for several years. The necessity of such research results from concern for saving metal and other materials and using them efficiently, for extending motor vehicle service life. It is known that the running life of many parts such as differential housings, drive gear flange sleeves and others is much shorter than the life of the vehicle as a whole. Worn parts are replaced with new ones or, if possible, rebuilt to the needed parameters by applying a powder coating and subsequently machining and surfacing them, requiring considerable additional expenditures of funds and time. Moreover, these parts generally lend themselves poorly to ordinary heat-treatment methods or simply cannot be worked at all, due to their complex shapes and to severe warping.

But when parts are laser tempered, their strength is increased two- to five-fold. It should be noted that, in addition, this technology, in a number of instances, permits the replacement of expensive materials with less-expensive ones -- medium-carbon steels in place of tool steels, for instance. It becomes no longer necessary to grind parts after heat treatment. Along with its improved productivity, the laser treatment achieves a big savings in thermal and electric power.

The work by laboratory specialists is bearing fruit. For example, as a result of research done jointly with the Physicotechnical Institute of the BSSR Academy of Sciences, technology has been developed for laser-processing such parts as lugs, upper arms and rocker arms.

The problem of using lasers in machinebuilding is essentially an interbranch one. It is precisely in consideration of these opportunities that the country has developed a special target comprehensive program. There is a council composed of eight sections on the various areas of technological laser use.

The scope of laser application in republic machinebuilding could be broader were a number of problems to be solved. First, there are quite simply not enough lasers, especially powerful ones. Their production is being delayed by a number of reasons, one of which is the lack of coordination in the actions of scientific, planning and planning-design organizations and industrial enterprises. New types of lasers are developed within academy laboratories, but neither the laboratories nor the institutes thus far have a production base which would raise these developments to a level suitable to broad industrial utilization. And in the traditional chain of introduction, at the stage at which academic achievements are transferred to the enterprises, branch institutes, instead of beginning engineering development on the devices, often review projects in an effort to make the development their own.

And even production itself is not ready yet to use laser technology extensively. Of all the republic machinebuilding enterprises, essentially only the Minsk Automotive Plant has taken the first steps along this line, and timid ones at that. Enterprises have no specialists in the industrial operation of laser equipment, and no republic VUZ is training them yet. The well-known conservatism in thinking has not been overcome: as before, the laser is viewed as a marvelous toy.

Analysis shows that industrial lasers can be introduced successfully at all the leading enterprises of republic machinebuilding and would save about a million rubles per year. The laser permits a sharp improvement in product quality and labor productivity, a sharp reduction in materials expenditure, and efficiency in the most decisive production sectors.

11052

CSO: 1823/105

OTHER METALWORKING EQUIPMENT

BRIEFS

DIAMOND-WHEEL CUTTER -- Until recently, cutting and processing some hard semiprecious stones at most enterprises in Armenia were done manually. The labor of high class specialists was spent on this, especially, when working on small stones which involved waste and low productivity of labor. In the "Armyanskiye samotsvety" Production Association of the Ministry of Local Industry of the Armenian SSR, that provides the jewelry plants of the country, inserts made of agates, jaspers, chrysalites and artificial corundums, this labor-intensive process was mechanized. Here engineers, technologists and innovators of the enterprise developed a machine tool mounted on an ordinary table, not requiring large production expenditures, designed to cut hard small natural and artificial stones mechanically. For cutting stones of various hardness, the diamond-wheel of the machine tool has corresponding rotation speeds and its cooling and lubrication with kerosene in the cutting process facilitates a high quality cut. The introduction of the new stone-cutting machine tool increased productivity considerably, automated the cutting process, provided a good finished surface of the cut, eliminated the need for additional polishing and made it possible to cut stones of minimal thickness. The annual saving by introducing one such machine stool is 3000 rubles. [By Yu. Nikogosyan] [Text] [Yerevan KOMMUNIST in Russian 16 Dec 83 p 1] 2291

ABRASIVE-BELT MACHINING -- A scientific practical seminar "New methods for abrasive processing of metals" was held in the "Armstanok" Scientific Production Association, organized by the association jointly with the city administration of the "Znaniya" Society. Scientists and specialists from Armenia, as well as Moscow, Leningrad, Kyubyshev, Kazan' and other cities in the country participated. Staff workers of the Transcaucasian branch of the Experimental Scientific Research Metal Cutting Machine Tool Institute made reports on the technology and equipment for abrasive-belt machining (SAO) of hydraulic turbine engine parts; and prospects of using SAO in machinebuilding; and on the treatment process with the present abrasive pastes. The seminar participants became acquainted with new developments of the Abrasive Processing Methods Department of the Transcaucasian branch of the Experimental Scientific Research Metal Cutting Machine Tool Institute and exchanged opinions. [By M. Gasangalyan] [Text] [Yerevan KOMMUNIST in Russian 3 Dec 83 p 4] 2291

DRILL, MILL, ASSEMBLE -- Khar'kov -- The new in principle machine tool was developed by the Khar'kov Aggregated Machine Tools Plant designers. It is distinguished from the previous ones in that in its design it was possible to combine drilling-milling operations with assembly operations for the first time. This machine tool can machine and assemble over 60 units and parts in only one hour and free five workers on the average from manual labor. [By V. Puzikov] [Text] [Kiev PRAVDA UKRAINY in Russian 13 Nov 83 p 2] 2291

AUTOMATED SERVICE CENTERS -- Minsk -- An automated service center that began operating at the Minsk Automobile Combine No 3 will eliminate unplanned automobile repairs and fuel losses due to faulty motors. The center mechanized all repair operations -- from tightening nuts to replacing units. The "Avtotranstekhnika" Association began series production of such automated centers. [Text] [Moscow SEL'SKAYA ZHIZN' in Russian 21 Dec 83 p 1] 2291

GRINDERS LACK CONTROL SYSTEMS -- Lubny, Poltava Oblast -- In the first two years of the five-year plan period, two outdated grinding machine tools were removed from production and the output of three new ones was assimilated. They increased the productivity of labor at the customer by 1½ to 2 times. The plan for this year specified the output of a new high precision machine tool. It has already been manufactured. Preparation was completed for the production of 20 more such machine tools next year. Then the ratio of new equipment will increase from 37 to 49 percent. Can this important indicator be increased? Yes. We already have the documentation for a promising circular grinding machine series developed by the Khar'kov Special Design Bureau. This consists of about 70 models for various purposes, degrees of automation and classes of precision of the machine tools. Their specifications are on the level of world specimens. Regrettably, the manufacture of the basic models is hindered by a lack of such complementing products as numerical control systems, linear sensors and step-by-step power motors. A shortage of the most highly skilled specialists at the plant also reflect negatively on the renovation rate of the manufactured equipment. The Ministry of Machine Tool and Tool Industry sends us, with difficulty, 10 people per year instead of the 40 we requested. These are the thoughts I want to share after reading the article of the Vladimirsk "Tekhnika" Association's director published in No 43 of the weekly. [By A. Birman, director of the "Kommunar" Machine Tool Building Plant] [Text] [Moscow EKONOMICHESKAYA GAZETA in Russian No 46, Nov 83 p 6] 2291

FORGE-PRESS PRODUCTION -- To me, as to managers of many other enterprises, problems that concern A. Nemontov, general director from Vladimir, are close and understandable. The share of basic products made by our own forces without involving outside organizations is 97 percent in our association. Forge-press machines make up about 40 percent of our annual output. In the two years and 10 months of the five-year plan period, the renovation coefficient of machines was 40 percent in the association. Many complicated problems arise. First, we develop annually "Schedules for preparation for production and assimilation of new machines" and "Schedules for preparation for production of the first industrial series and series production." They establish optimal times from developing the technical documentation to the

manufacturing of a prototype and shipping it to the customer. Secondly, the designers use widely a comprehensive design method which consumes the utilization of approved units, systems and assemblies on machines different in force and purpose. The technical calculations group developed a set of programs for full kinematic, power and strength calculations of the presses. Calculation results are printed out by a computer printer in the form of finished lists. Manual calculation of the pneumatic hammer actuator took, for example, 120 hours of working time. The introduction of the program for selecting optimal parameters makes it possible to solve this problem in two hours by analyzing several hundred versions. [By A. Krupenko, general director of the Voronezh Production Association for Manufacturing Forge-Press Equipment imeni M. I. Kalinin] [Text] [Moscow EKONOMICHESKAYA GAZETA in Russian No 50, Dec 83 p 6] 2291

ELECTRO-SLAG CASTING -- Kiev -- A heavy steel ingot is lowered slowly into the opening of the electro-slag casting installation. The metal gets red-hot by the high temperatures. The operator only watches the instruments, while the process proceeds automatically. Here a signal indicates the end of the technological process. A furnace chamber opens up at the bottom of a five-meter depth and a single-rail overhead traveling crane brings up a carriage base sizzling with heat -- one of the parts of a future machine tool. Thus, in the Kiev Automatic Machine Tool Plant imeni Gorkiy, there is an automated system for controlling the electro-slag casting process for the first time in the country. It has considerable advantages. The surface of the ingots produced is almost mirror-like and does not require, as it did previously, rough turning. This makes it possible to save up to 200 kilograms of steel in manufacturing each carriage. The introduction of the system promises annual savings of 50,000 rubles. The success was possible due to the help of many collectives. Scientists from the Electric Welding Institute imeni Ye. O. Paton calculated and developed a mathematical model of the system; a computer was received from Orel; and the program for it -- from Severodonetsk. Considerable contributions were made by specialists from fraternal countries: disks with cassettes were manufactured in Bulgaria; the alpha-numeric printer is of Polish manufacture; microcircuits and individual parts were received from Czechoslovakia and the GDR. The new automated system has many advantages," stated V. P. Varusha, engineer-programmer. "The computer prepares and issues technical video documentation-report in the process of melting. This same data is stored by the computer in its memory which makes possible a constant search for more optimal version of the process." [By V. Koval'chuk] [Text] [Kiev PRAVDA UKRAINY in Russian 19 Nov 83 p 2] 2291

ELECTROCHEMICAL MACHINING -- At the Kama Automobile Plant, two new machine tools models, EZ-112 and EZ-113, were released for operation to be incorporated in an automatic line for machining crankshafts. These machine tools were created by collectives of the Transcaucasian branch of the ENIMS [Experimental Scientific Research Metal-Cutting Machine Tools Institute] and the Yerevan Experimental "Armstanok" Scientific Production Association. One of the basic subjects of the Transcaucasian branch of the ENIMS is the development and creation of technological processes and machine tools

for electrochemical dimensional processing of parts and their introduction in industry. The advantage of this method is the elimination of cutting tool wear, the possibility of machining any metal and alloys independently of their hardness. The first model EZ-111 machine tool was sent to the Kama Automobile Plant in 1981. The automatic machine tools created for the automobile builders are designed to remove burrs from the internal surfaces of the channels of the rocker support and polish and round the edges of lubricating holes and other operations. After assembling experimental specimens, association specialists A. Aleksanyan, V. Grigor'yev, S. Davtyan and L. Grigor'yan, under the guidance of Z. Demirchyan, chief engineer of the Yerevan Experimental Plant, and S. Akopyan, senior staff worker of the Transcaucasian branch of the ENIMS and candidate of technical sciences, released for operation to the Kama Automobile Plant automatic machine tools of high quality on schedule. The total saving from introducing the development was 250,000 rubles. The Yerevan people won the right to supply the equipment in competition with eminent firms abroad. The department of electrochemical methods of processing has many other creative discoveries to its credit. Since the start of the five-year plan period, nine new models of the machine tools were introduced at metalworking plants in the country. The collective is working on another important task: three models of high productivity automatic machines for electrochemical processing of the piston and crankshaft of the "Don-1500" combine engines. [By M. Gasangalyan, engineer ENIMS Information Department] [Text] [Yerevan K. COMMUNIST in Russian 15 Nov 83 p 2] 2291

PLASMA MACHINING -- Ryazan' -- The creative collective of the Ryazan' Machine Tool Building Plant created a special design machine tool to process large size parts made of fire-resistant steel alloys. The cutting tool of the machine tool is plasma, while an industrial TV is used to observe how the plasma cuts the metal. The new machine tool is economical to operate and provides high productivity of labor. [Text] [Moscow SEL'SKAYA ZHIZN' in Russian 19 Nov 83 p 1] 2291

CSO: 1823/90

AUTOMATED LINES AND AGGREGATED MACHINING SYSTEMS

CZECHOSLOVAK NC MACHINE TOOLS TO SOVIET AUTO PLANTS

Yerevan KOMMUNIST in Russian 16 Dec 83 p 3

[Caption to photo (reproduced) of a shop at the "TOS-Kurzhim" machine tool manufacturing plant in Czechoslovakia]

[Text] Czechoslovakia . Producing machine tools with numerical programmed control and automatic lines is the basis of the production program at the "TOS-Kurzhim" machine tool manufacturing plant. It is producing the machines of the future, machines capable of the most complex production operations following a prescribed program. The Soviet Union is one of the enterprise's main trading partners. Large lots of machine-tool equipment will be sent to the Volga and Kama automotive plants, to Moscow, Leningrad, Minsk and Ulyanovsk this year.

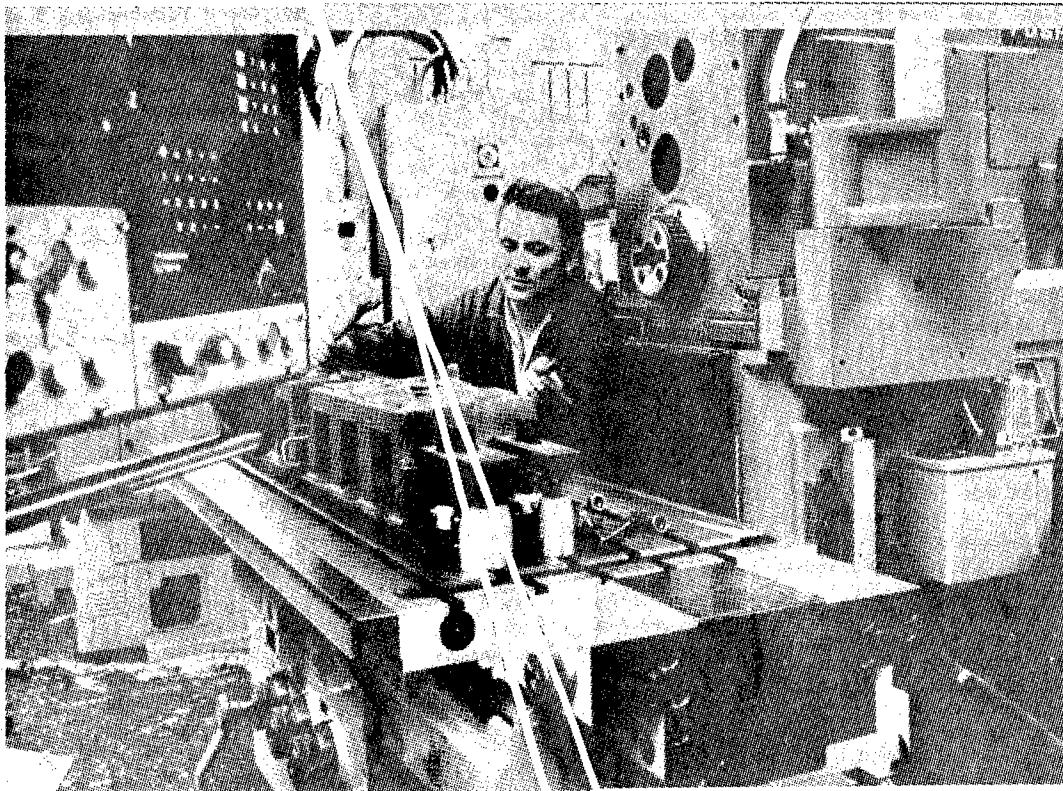

11052
CSO: 1823/83

AUTOMATED LINES AND AGGREGATED MACHINING SYSTEMS

SOME ELECTRONIC CONTROL FEATURES OF FMS VIEWED

Moscow PRAVDA in Russian 27 Dec 83 p 2

[Article by V. Gerasimov, dateline Leningrad, under the heading "Equipment of the Five-Year Plan": "'Common Language' With the Machine"]

[Text] The "Plant imeni M. I. Kalinin" association in Leningrad has started industrial pilot operation of a flexible automated complex for designing and machining parts (on a lathe). This significantly reduces the time from the start of engineering development to actualization of the parts in metal; it sharply improves the equipment use factor, increases labor productivity and improves product quality dozens-fold, and consequently eases the transition to so-called unmanned technology.

Maneuvering among the machine tools, a miniature transport robot moves to the stock area and freezes at the transfer device at exactly the moment that an automatic stock-piling machine arrives with a magazine of blanks from the labyrinth of shelves. Mechanical "arms" grasp it, move it to a platform, and the robot goes to a machine tool where blanks are on their way out. It then delivers another magazine with finished parts to the storage area. It apparently chooses a route itself, because at the proper moment it appears alongside the one of the four lathes where it is needed, and with those blanks which will ensure continuous operation of the equipment.

Just one year ago, this picture one can observe today in the shop would have been considered a fantasy by association specialists, although they had long been successfully involved with production automation. The enterprise has an extensive products list which is updated quite rapidly, so the traditional methods of automation, which are effective in mass or large-series production, would be complex and unprofitable here. There was only one way, to introduce flexible automated production facilities.

In order to obtain the desired results, proponents urged that the problem be resolved from the very first in a comprehensive manner, uniting the processes of planning, designing parts and technologies, transport, metalworking and monitoring into a common system. The task initially seemed too hard. Scientists came to their aid. Now that the complex is in operation, those in the association have much good to say about the theoretical and practical developments by specialists of the Leningrad Scientific Research Computer Center of the USSR

Academy of Sciences -- director V. Ponomarev, deputy director A. Domoratskiy, chief engineers I. Belyakova and A. Safarov, and many others -- who worked on developing this production facility of the future. With their help, a "common language" was found for the computers controlling all the processes and they acquired the ability to respond instantaneously to any need, to track all links in the far-flung network of technological operations. Workers at a number of enterprises and organizations in Moscow, Tula, the Institute of Nuclear Energy imeni I. V. Kurchatov, and the Institute of Technical Cybernetics of the BSSR Academy of Sciences helped find the best variant for the complex. The engineers and workers themselves modernized the machine tools and improved series-produced robots to conform to the requirements of the automated production facility. A number of original devices were developed thanks to the inventiveness of chief engineer V. Smekhov. There was also wide recognition of the contribution of engineers O. Shcherbachev, T. Tishchenko and Yu. Kiyani at the association.

In addition to numerous technical difficulties, they were forced not only to reorganize planning and management, but also to change people's views, to help them learn to think in new categories. Those at the enterprises recall one thing that happened very early in development of the complex. Machine tool operators were skeptical of the robots, as they were slower than people in setting up a part for machining and removing it. A time and motion study was made, and an experienced lathe operator was dismayed to find out how much time was actually spent each shift in actually cutting metal on his machine. When the exact same group of machines was computer-controlled, that time turned out to be twice as long -- the programmed equipment did not, after all, ponder its assignment, take a smoke break.... Two numerical programmed-control machines set for optimal load were installed in this shop. The equipment turned out to have been fully capable of coping with its program. But the shop requested that several more such machines be installed "for insurance." Subsequent events showed that, given a qualitatively new approach to compiling daily-shift assignments on computers and to servicing the equipment, no additional capacity was needed. True, it is always hard to overcome the inertia of views and habits. The collective of the "Plant imeni Kalinin" association has taken a step in this direction.

...In a dialog with the designer, the computer traces on its display the part he has dreamed up. Another instruction is given. The computer offers a control program and technological process: operating conditions, machining tools, number of operations, time. The labor productivity of designers has risen several-fold. The flow chart and control program in the computer memory can, when needed, be communicated to robots and metal-cutting machine tools. Production will then begin to operate automatically. It has now designated 35 different types of parts for lathe machining.

Production workers and scientists have as their immediate goals improving the reliability of all links in the complex so that its elements can be circulated. Using the experience acquired, one can begin developing in earnest analogous production facilities for milling and drilling body parts.

Similar work at other Leningrad enterprises also points to the future. At a number of associations, integrated complexes and flexible automated production facilities help increase output, and such sectors are becoming operational at several plants.

ROBOTICS

DEVELOPMENT OF ROBOTS FOR INDUSTRY AND AGRICULTURE

Riga SOVETSKAYA MOLODEZH' in Russian 21 Sep 83 p 2

[Article by Candidate of Economic Sciences B. Frumkin, under the heading "CEMA In Action": "Robots Preparing to Go To the Countryside"]

[Text] We are gradually growing accustomed to the concepts of "robotization," "robot engineering" and "robot manufacturing." This line of engineering thought is moving from the world of the fantastic into people's actual lives, and foremost into that portion linked to their labor activity. In a number of socialist countries, a program for producing and using industrial robots in accordance with the resolutions of the most recent party congresses is being carried out this five-year plan. It has been proposed that the number of such robots reach 200,000 in CEMA member-nations as a whole by the year 1990.

The very name "industrial robot" is involuntarily associated with the broad area of their application: servicing forge-press, foundry, welding, metal-cutting, painting and other equipment. In fact, industrial enterprises are and will be the largest consumers of robots. This is associated with the fact that their introduction is the most effective and sometimes the only path for production progress. It permits a sharp reduction in monotonous, low-skill labor, compensating for the shortage of human resources, raising the level of use of basic technical equipment, and a changeover to comprehensive production automation.

But these same problems are no less pressing for agriculture, more urgent in a number of instances. Production intensification involving fundamental improvement in labor content and working conditions in agriculture is a necessary prerequisite to developing the agroindustrial complex and, consequently, to improving the material well-being of the entire populace of the nations of socialism. Therefore, regardless of the limited world experience in this area, the CEMA states have begun actively developing the questions of agricultural robot manufacturing. These are foremost agricultural enterprises using industrial production technology in agricultural equipment maintenance and repair and in agrochemical services.

The agroindustrial complex needs all generations of robots: first (manipulators, to replace manual labor in repetitive operations), second ("hand-eye" manipulators) and third (robots with the technical faculties for imitating intellectual functions).

Second- and third-generation robots are most "capable" of imitating the human actions especially necessary for agriculture. By interacting not only with inanimate objects, but also with plants and livestock, and by functioning in various environments in which it is not always possible to determine a work program and working conditions ahead of time, they must be superior to their industrial brothers in a number of parameters. This circumstance complicates their development and introduction into production. Nonetheless, developments in agricultural robot manufacturing in several CEMA countries, and especially in the USSR and GDR, have yielded promising results.

For example, the model MAR-1 Soviet agricultural robot is equipped with two "arms" which act like human arms. Using both "arms," the robot can lift up to 150 kg. Its "fingers" control a broad range of gripping force and monitor temperature, humidity and other environmental parameters. The robot can regulate a microclimate and disinfect farm premises, and it is even capable of determining the thickness of the fat layer in hogs. In a word, the range of operations it performs is very broad. The MAR-1 is designed on a unit principle, permitting comparatively easy and rapid replacement of any given subassembly which might malfunction during operation.

Soviet specialists have also developed manipulators for cleaning cow udders before milking and also for mechanical milking. GDR scientists have substantiated the technological requirements on manipulators for the harvesting and initial processing of potatoes. Along with a sharp reduction in manual labor expenditures, these automatic machines permit the more intensive use of available equipment.

Mechanical milking manipulators, for example, ensure optimum stripping completeness, they can be mounted on series-produced milking machines, and they enable one operator to process at least 70-80 cows per hour. USSR agriculture will require several thousand such robots alone by 1990.

Other robot models designed to care for plants, to transplant agricultural crops, to weed and perform several other types of field operations, to gather and sort horticultural output, are also being developed.

However, given all their results, national developments are inadequate for balanced progress along the necessary lines of agricultural robot manufacturing. The socialist countries have therefore decided to combine their available scientific-technical potential in this area. The "Mechanization, Electrification and Automation of Production Processes in Plant Cultivation and Stockraising" coordination center operating within the CEMA framework has conducted a preliminary study of the possibility of manufacturing agricultural robots in countries of the region. Joint work will be continued on this basis, with practical results anticipated as early as 1984.

The widespread application of robots in agriculture is naturally a matter for the future, but perhaps not all that remote a future. The path from scientific development to mass production, from the first generation of robots to the third, is not an easy one. However, the tasks of agricultural robot manufacturing are entirely feasible given purposeful, planned, coordinated growth in the national and international efforts of the countries of the socialist community.

11052

CSO: 1823/78

END