

R  
076166

JPRS 82703

21 January 1983

**DISTRIBUTION STATEMENT A**  
Approved for public release  
Distribution Unlimited

# China Report

SCIENCE AND TECHNOLOGY

No. 184

DTIC QUALITY INSPECTED 4

19980320 111

**FBIS**

FOREIGN BROADCAST INFORMATION SERVICE

REPRODUCED BY  
NATIONAL TECHNICAL  
INFORMATION SERVICE  
U.S. DEPARTMENT OF COMMERCE  
SPRINGFIELD, VA. 22161

8  
24  
A02

#### NOTE

JPRS publications contain information primarily from foreign newspapers, periodicals and books, but also from news agency transmissions and broadcasts. Materials from foreign-language sources are translated; those from English-language sources are transcribed or reprinted, with the original phrasing and other characteristics retained.

Headlines, editorial reports, and material enclosed in brackets [ ] are supplied by JPRS. Processing indicators such as [Text] or [Excerpt] in the first line of each item, or following the last line of a brief, indicate how the original information was processed. Where no processing indicator is given, the information was summarized or extracted.

Unfamiliar names rendered phonetically or transliterated are enclosed in parentheses. Words or names preceded by a question mark and enclosed in parentheses were not clear in the original but have been supplied as appropriate in context. Other unattributed parenthetical notes within the body of an item originate with the source. Times within items are as given by source.

The contents of this publication in no way represent the policies, views or attitudes of the U.S. Government.

#### PROCUREMENT OF PUBLICATIONS

JPRS publications may be ordered from the National Technical Information Service, Springfield, Virginia 22161. In ordering, it is recommended that the JPRS number, title, date and author, if applicable, of publication be cited.

Current JPRS publications are announced in Government Reports Announcements issued semi-monthly by the National Technical Information Service, and are listed in the Monthly Catalog of U.S. Government Publications issued by the Superintendent of Documents, U.S. Government Printing Office, Washington, D.C. 20402.

Correspondence pertaining to matters other than procurement may be addressed to Joint Publications Research Service, 1000 North Glebe Road, Arlington, Virginia 22201.

CHINA REPORT  
SCIENCE AND TECHNOLOGY

No. 184

CONTENTS

PEOPLE'S REPUBLIC OF CHINA

APPLIED SCIENCES

Features of Nuclear Submarines outlined (Shi Lei; HE DONGLI GONGCHENG, Aug 81) .....	1
Nation Completes Its First Large-Scale Solar Observatory (RENMIN RIBAO, 22 Dec 82) .....	4
PRC Develops Nuclear Energy for Peaceful Uses (XINHUA, 27 Dec 82) .....	6
PRC Develops Automatic Quake Observation System (XINHUA, 23 Dec 82) .....	8
Briefs	
Proton Linear Accelerator Operational	10
Deep Seabed Specimens	10
New Mineral Discovery	10
Marine Seismic Detector System	11

LIFE SCIENCES

Improved Radiation Safety Precautions for Radioisotope Workers in Shanghai (Fu Shanlai; JIANKANG BAO, 8 Aug 82) .....	12
Tibet Launches Stomach Cancer Survey (Shao Yongfu; JIANKANG BAO, 1 Aug 82) .....	14

Advances in Diving Medicine Research Being Made (He Yi, et al.; GUANGMING RIBAO, 17 Aug 82) .....	15
--	----

ABSTRACTS

AUTOMATION

ZIDONGHUA XUEBAO [ACTA AUTOMATICA SINICA], No 4, 1982 .....	17
---	----

METALLURGY

GANGTIE [IRON AND STEEL], No 9, 1982 .....	19
--	----

## APPLIED SCIENCES

### FEATURES OF NUCLEAR SUBMARINES OUTLINED

Beijing HE DONGLI GONGCHENG [NUCLEAR POWER ENGINEERING] in Chinese No 3,  
Aug 81 pp 95-96

[Article by Shi Lei [4258 4320]]

[Text] A modern missile-carrying nuclear submarine can travel at a speed of 30-40 knots, which exceeds the speed of many surface ships. It can engage in sea combat at a depth of 400 meters, which is eight times the capability of early submarines. It can survive for several years without refueling; and its range and endurance are almost unlimited. Its cruising period is primarily determined by the physiological conditions of the crew members and considerations of supplies and maintenance. A nuclear submarine can carry 10-20 missiles; if the range of missile is approximately 5000 km, then an ocean-borne nuclear submarine can deliver missiles to essentially any location of an enemy territory. By utilizing the ocean as a natural cover and by taking advantage of its underwater mobility, a submarine can easily avoid damage during a nuclear first strike. Therefore, most powerful naval nations use nuclear-missile submarines as strategic weapons to ensure second strike capability and nuclear retaliation.

The strategic value of a nuclear submarine is attributed to its unique characteristics. The "heart" of the submarine is its nuclear power plant, which generates enormous amounts of energy to propel the submarine rapidly through the ocean. It can travel either on the surface or submerged; it does not burn coal, nor does it require petroleum or air. Its fuel is a metal--uranium, commonly referred to as nuclear fuel. The amount of energy released by "burning" 1 kg of U-235 nuclear fuel is equivalent to that from burning 2,000 tons of coal. Since oxygen is not required for combustion, a nuclear submarine can remain submerged for long periods. Furthermore, because of the small amount of fuel required, a nuclear submarine can travel a long distance (several times around the globe) after one refueling. This type of nuclear power plant is generally composed of two separate closed-loop circuits, as shown in the illustration. The primary circuit contains the reactor, pressure stabilizer, a steam generator, and a circulating pump. The secondary circuit contains a steam turbine, a condenser, and a condensed water pump.

The reactor contains a large amount of nuclear fuel which is usually shaped in the form of pellets and packed in slim metal tubes called fuel rods. The chain

reactions of neutrons cause fission in the nuclear fuel U-235, and at the same time release large amounts of energy. This energy is generally released in the form of heat, causing the temperature of the nuclear fuel to rise; the heat is transferred through the surface of the fuel rods and carried away by the high-temperature, high-pressure, rapidly circulating coolant (water) which circulates in the primary reactor circuit. Carrying heat energy from the reactor, the coolant enters the steam generator, which is generally composed of a bank of tubes through which circulates the high-pressure, high-temperature water of the primary circuit. Outside the tubes flows a mixture of steam and water circulating in the secondary circuit. In this manner, heat energy is continuously being transferred from the primary circuit to the secondary circuit, and the water there is continuously being converted into steam. After leaving the steam generator, the water in the primary circuit passes through a circulating pump, and returns to the reactor to further absorb heat energy released from nuclear fission. The heat is again transferred to the steam generator where water from the secondary circuit is vaporized. By repeated circulation of the water in the primary circuit, the process of continuous heat transfer is accomplished.

The water in the secondary circuit continuously absorbs heat through the steam generator and continuously evaporates into steam. By passing through a phase separator, the "dry" steam flows into the steam turbine, where its heat energy is converted into mechanical (rotational) energy. The rotational energy of the turbine is transmitted to the main axle of the submarine through a speed reduction gear box, thereby turning the propeller and pushing the submarine forward. A power plant such as this can also be used to propel other vessels.

To ensure safe operation, the pressure of the reactor must be maintained at a stable level; i.e., the pressure fluctuations must be very small. To maintain pressure stability in the primary circuit a pressure stabilizer is generally installed where the primary circuit exits from the reactor. The stabilizer is a high-pressure container whose lower part has an electric heating element and is filled with water; the upper part is filled with steam and is equipped with a spray nozzle. If for some reason the submarine is suddenly commanded to accelerate, the steam consumption in the turbine will suddenly increase and the temperature in the secondary circuit will decrease. This sudden demand is transmitted through the steam generator and causes the temperature and pressure in the primary circuit to drop. This change in temperature and pressure is sensed by the automatic control system which activates the electric heating element in the pressure stabilizer. As a result, more water is evaporated and the pressure is restored in the container. Similarly, if the speed of the submarine is reduced, the load on the turbine is decreased, and the pressure in the primary circuit will rise. The automatic control system will then activate the spray nozzle to spray the comparatively low-temperature water from the entrance to the reactor onto the steam which occupies the upper part of the pressure stabilizer. This causes part of the steam to condense and lowers the pressure in the primary circuit. In this manner, the pressure in the reactor can be maintained at a constant level, and the submarine can maneuver safely in the vast ocean in response to human commands.

It is clear from the simple description of the operation of nuclear submarine that it does not require frequent refueling, nor does it require a separate fuel tank; the several hundred kilograms of nuclear fuel are stored in the reactor. Also, since the nuclear power plant can operate without oxygen, the nuclear submarine not only can remain submerged for a long period, but also has considerable capacity to allow additional payload and space for installing weapons and for improving the living conditions of crew members. Consequently, the superior characteristics of the nuclear-powered submarine cannot be matched by conventional submarines.

In addition to the several hundred nuclear submarines currently in existence around the world, nuclear power plants have been installed in other vessels; these also have demonstrated the incomparable superiority of nuclear power. For example, they have been used on nuclear aircraft carriers such as the U.S. "Enterprise," the "Nimitz," the "Eisenhower," and the "Vinson"; the Soviet Union is also building a 50,000-ton class nuclear aircraft carrier. Nuclear power plants are also used on ocean cruisers. The famous Soviet icebreaker "Lenin" is also powered by a similar nuclear power plant. The nuclear merchant ship "Otto Hahn" built by West Germany has traveled over 640,000 nautical miles. Japan has not only built the nuclear-powered ship "Mutsu," but has also proposed designs of nuclear-powered underwater oil tankers. On the basis of the current trend of development, we firmly believe that the application of nuclear power in oceanic transportation has a bright future. It is not inconceivable to imagine that some day a nuclear-powered underwater ocean liner may be developed; at that time, travelers not only can cross the Pacific or the Atlantic in total calmness, but also will be able to enjoy the fascinating scenery at the bottom of the ocean.

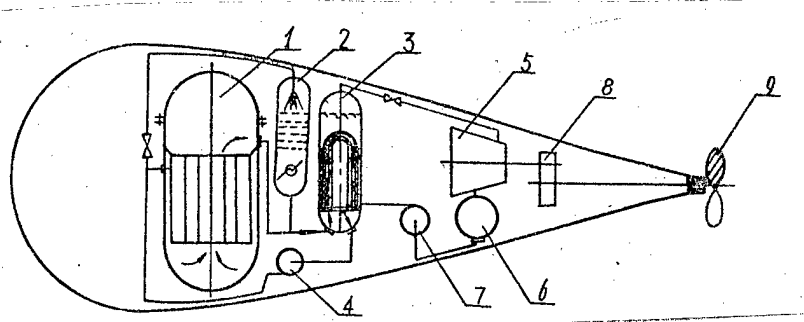

Schematic Diagram Showing the Propulsion System of a Nuclear Submarine

- |                         |                              |
|-------------------------|------------------------------|
| 1. reactor;             | 6. condenser;                |
| 2. pressure stabilizer; | 7. condensed water pump;     |
| 3. steam generator;     | 8. speed reduction gear box; |
| 4. circulating pump;    | 9. propeller                 |
| 5. steam turbine;       |                              |

3012  
CSO: 8111/1074

APPLIED SCIENCES

NATION COMPLETES ITS FIRST LARGE-SCALE SOLAR OBSERVATORY

Beijing RENMIN RIBAO in Chinese 22 Dec 82 p 4

[Text] China's first large-scale solar observatory has recently been completed at the Purple Mountain Observatory in Nanjing. This big observatory is among the 20 or so largest such observatories in the world today. All major targets have been determined by experts to have met or surpassed design specifications.

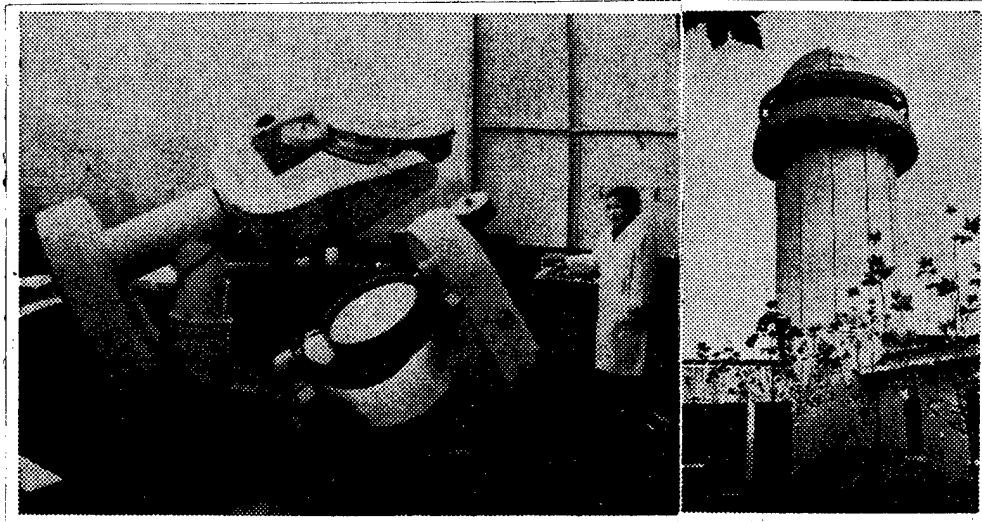

The sun-tracking telescope at the top of the observatory.

Exterior view of China's first solar observatory

CSO: 4008/36



APPLIED SCIENCES

PRC DEVELOPS NUCLEAR ENERGY FOR PEACEFUL USES

OW271301 Beijing XINHUA in English 1137 GMT 27 Dec 82

[Text] Beijing, 27 Dec (XINHUA)--China is developing atomic energy in the service of the national economy and people's livelihood, according to a spokesman for the Ministry of Nuclear Industry.

The spokesman predicted today that nuclear power will become an important source of energy, especially for areas short of coal, oil or water power.

The two nuclear power stations planned to be built in Zhejiang and Guangdong Provinces will usher in a new age in the peaceful use of nuclear power and technology, he said, and more such installations are being considered for other energy-short areas.

Production of radioactive isotopes is another major aspect in the peaceful use of nuclear power and technology. The spokesman revealed that China now has several reactors producing radioactive isotopes. These reactors owned by the Ministry of Nuclear Industry alone are producing more than 230 kinds of isotopes for more than 1,200 users throughout the country. In addition, there are more than 100 nuclear irradiators installed in all provinces, municipalities and autonomous regions except Tibet, he said.

Isotope technology is now applied in many fields, including agriculture, industry, medical treatment, physics, chemistry, biology, geology, archaeology and environmental protection.

The spokesman said that, using irradiation or combined methods, Chinese agronomists have succeeded in developing 150 high-yielding crop strains.

"Yuanfeng Zao," a rice strain developed by the Zhejiang Academy of Agricultural Sciences through irradiation, ripens 45 days earlier than the original strain and yields ten percent more than other varieties of the same growth period.

"Lumian No 1," a new cotton variety also developed through irradiation by the Shandong Provincial Cotton Research Institute, had been planted on two million hectares up to 1981 and yielded an extra 450,000 tons.

Preceding page blank

Nuclear medicine research is also developing in China. More than 700 hospitals are using radioactive isotopes to diagnose and treat diseases. The accuracy rate for diagnosing thyroid hyperfunctioning by isotope technology is reported to be as high as 85 to 95 percent.

A liver cancer survey by the serum alpha fetoprotein radioactive immune assay among 180,000 people in a high-incidence area accurately found 300 cases, 134 of which were at an early stage of the disease, where no symptoms are apparent.

Nuclear medical methods are used in theoretical research in biochemistry, pharmacology, genetics and fundamentals of acupuncture anaesthesia, enriching the theory of Chinese traditional medicine.

Gamma rays and neutrons are used to measure the depth of wells and search for underground water.

Positive results have also been reported in using nuclear radiation to test meters for industrial automatic control and measurement, the ministry spokesman said.

CSO: 4010/31

## APPLIED SCIENCES

### PRC DEVELOPS AUTOMATIC QUAKE OBSERVATION SYSTEM

OW230810 Beijing XINHUA in English 0738 GMT 23 Dec 82

[Text] Shanghai, 23 Dec (XINHUA)--China's first automatic seismological observation and data processing system for telemetric seismological networks went into operation here today.

The system was appraised at a six-day meeting, which closed here today, organized by the State Seismological Bureau. Experts and engineers present said that the concept and the design requirements for logic and functions of the system meet advanced standards.

The system is the basic part of the telemetric seismological regional networks that China is establishing separately in Shanghai, Beijing, Kunming, Chengdu, Lanzhou and Shenyang. The Shanghai network has performed well during a trial run of more than a year, the meeting said. The other five networks are being developed.

Each telemetric seismological network is composed of an earthquake-monitoring system, a quake-indicator observing system, a data telegraphing and telemetering system, a data-processing and storage system, a time-regulating system and power supply.

The quake-monitoring system of each network is equipped with surface and deep-well observing seismographs with magnifying power ranging from one to hundreds of thousands and the frequency ranging from 0.005 Hertz to 20 Hertz. The system can pool, record and process 117 routes of seismic signals.

Within a short time after the occurrence of a strong earthquake in China or abroad and the seismic wave has reached the observation stations, the system can quite accurately determine the basic parameters of the quake and take complete notes, the meeting said.

The quake-indicator observing system can periodically produce controlling signals to start and stop the operation of meters and instruments at the field observation stations, which can automatically observe and telemeter various geophysical and geochemical signals concerning earthquakes. The signals include the changes of the intensity of geo-magnetic field, the apparent earth resistivity, the content of radon in underground water, the crustal stress, the

faulting of the land, air temperature, atmospheric pressure, waterfalls and others. At most, the system can collect, telemeter, arrange and process 1,200 signals from 40 field stations, the meeting reported.

The data gained by the field stations can be quickly telegraphed or telemetered to the regional network center. The data processing system equipped at the center includes computers, seismic triggers, map-marking instruments and other equipment. The center can quickly process and store in different forms large amounts of data.

A high-precision digital clock station and a coding remotesensing regulation device at each center can provide a time standard for the whole system and undertakes automatically regulating time for all its field observation stations.

Most of the equipment of the system including computers were designed and made by China. The software, namely the special-purpose computer programs, was all developed and readjusted by Chinese technicians.

CSO: 4010/31

## APPLIES SCIENCES

### BRIEFS

PROTON LINEAR ACCELERATOR OPERATIONAL--Beijing, 21 Dec (XINHUA)--The High Energy Physics Institute under the Chinese Academy of Sciences recently completed construction of a 10 million electron volt proton linear accelerator in the western suburbs of Beijing, the biggest of its kind in China so far, according to Xie Jialin, deputy director of the institute. The accelerator was initially adjusted and began producing a beam of protons at 0300 on 17 December. The energy of the beam was 10 million electron volts and its intensity was 14 miliamperes. Readjusting work is now going on to further raise the intensity of the beam. The completion of the accelerator was a breakthrough in China's development of accelerators, Deputy Director Xie Jialin said. [Text] [OW221309 Beijing XINHUA in English 1143 GMT 21 Dec 82]

DEEP SEABED SPECIMENS--Beijing, 10 Dec (XINHUA)--China has for the first time collected biological and mineral specimens from a 5,137-meter deep seabed. The Stat Oceanography Bureau said that the collection of the specimens is another major advancement in developing the technology of deep-sea surveying. The "Xiangyanghong No 16," a new 4,000-ton survey ship of the East Sea Branch of the National Bureau of Oceanography, collected the specimens in its trial voyage in northwest Pacific Ocean, where the water is more than 5,000 meters deep. China's previous record in collecting deep-sea specimens was 3,949 meters. Using a domestic-made hydraulic winch with a 13,700-meter-long steel cable drawing a benthonic trawl, the ship collected lapilluses, a fragment of lava, which fell into the sea billions of years ago, and nodular ore bodies as well as varieties of benthonic specimens from the sea floor. The ship also collected surface and columnar geological materials from the bottom of the sea by using a geological winch with a 6,000-meter-long steel cable. These specimens and materials are now being identified, the bureau said. [Text] [OW221309 Beijing XINHUA in English 0243 GMT 10 Dec 82]

NEW MINERAL DISCOVERY--Beijing, 10 Dec (XINHUA)--A new mineral xitieshanite, hydroxyl-bearing ferro sulphate, has been discovered by Li Xilin of the Institute of Geochemistry under the Chinese Academy of Sciences, in cooperation with Zhou Jingliang and Li Jiaju of the Institute of Geology. The mineral lies in the oxidation zone of the lead-zinc deposits in Xitieshan, Qinghai Province. The mineral, semi-transparent to transparent, is light green to lemon yellow with yellow streaks and vitreous lustre. On 19 August, Dr Akira Kato, chairman of the Commission on New Minerals and Mineral Names under the International Mineralogical Association, officially informed scientist Li Xinlin that the

commission recognized xitieshanite as a new mineral. Chinese scientists have conducted a detailed analysis of the mineral's physical and chemical properties and composition. They said that the discovery will be helpful in understanding the local geological conditions and has provided clues for looking for lead, cooper, zinc and sulphide deposits. [Text] [OW221309 Beijing XINHUA in English 0723 GMT 10 Dec 82]

MARINE SEISMIC DETECTOR SYSTEM--Tianjin, 15 Dec (XINHUA)--China has developed a detector system for marine seismic geological surveying, the Marine Geological Survey Bureau of the Ministry of Petroleum Industry said today. The system, verified by experts as up to or approaching international standards in major technical norms, has been used in seismic geological surveying in the East China, the Bohai and Yellow Seas, and the results were as good as expected. A Marine Geological Survey Bureau engineer described the system as a 3-kilometer long device towed by a seismic surveying ship. Hydrophones in the device detect seismic waves caused by underwater detonations set off by the ship sailing along a prescheduled survey line, and then transmits electric signals to a digital seismic recorder on board the ship. Simultaneously, the signals are processed by a computer and translated into geological data. China began developing the system in 1979 and by April 1981, two types had been built. [Text] [OW221309 Beijing XINHUA in English 1230 GMT 15 Dec 82]

CSO: 4010/31

IMPROVED RADIATION SAFETY PRECAUTIONS FOR RADIOISOTOPE WORKERS IN SHANGHAI

Beijing JIANKANG BAO in Chinese 8 Aug 82 p 2

[Article by Fu Shanlai [0265 0810 0171] and Xu Huaijin [1776 2037 6815]]

[Text] Since the city of Shanghai decided to put into place an effective radiation safety program for radioisotope workers, the quality of such measures has continued to improve. Not only does this protect the health of those working with radioactive materials, it also protects the environment.

Radioisotopes were first used in Shanghai in 1958. During the last 20-some years, the Shanghai Health Department has adhered strictly to radiation safety regulations promulgated on a national level and has closely monitored the 166 newly built or remodeled units where radioisotopes or other radiation have been used. For the 78 units that practiced good radiation safety, a "Registration Permit for Work With Radioisotopes in Shanghai" was issued.

The fact that Shanghai can practice an effective safety program is due mainly to its reliance on the masses and the instigation of technical innovation. The Changning Hospital Center has used a micro-pump to successfully devise an automatic injection apparatus that is dependable and easy to operate. Use of such a device can reduce the exposure hazard for medical workers when they give injections that are radioactive. The First People's Hospital of Shanghai experimented and designed an automatic radium washer that can disinfect and substitute for most of the storage and assembling operations as well as wash. It needs only one operator, saves on labor, and cuts down radiation exposure dose. The Rujin Hospital is one of the earliest centers in the city to use radioisotopes for diagnosis and treatment. Following increased radioisotope use and overcrowding of nuclear medicine laboratory facilities, the radiation exposure dose for medical workers was obviously increased. Consequently, with collaboration from related groups, the medical and radiation safety personnel of this radioisotope laboratory initiated some radiation safety technical reforms and obtained good results.

In the disposal of medical radioactive wastes, the Shanghai Sixth People's Hospital joined with the Shanghai Industrial Construction and Design College and the Jingan District Environmental Sciences Society in 1979 to experimentally manufacture a model FH-1 water purifier, which can successfully

treat radioactive wastes resulting from medical and laboratory use. A joint collaboration unit at the Shanghai Institute of Industrial Health also successfully designed and completed an incinerator that can burn 20 kilos of radioactive wastes per hour. After several burnings, 27 tons of long half-life radioactive wastes have been processed, thereby reducing storage volume by 95 percent, weight by 96 percent, and presenting a new method to prevent inflammable wastes from contaminating the environment.

5292

CSO: 4008/216



LIFE SCIENCES

TIBET LAUNCHES STOMACH CANCER SURVEY

Beijing JIANKANG BAO in Chinese 1 Aug 82 p 2

[Article by Shao Yongfu [6730 3057 1318]]

[Text] Stomach cancer is the most common malignant tumor affecting the health of the various national minorities in Tibet. According to statistics compiled from retrospective data on the causes of death from cancer for the whole region and from clinical autopsy data, stomach cancer is the leading cause of death, accounting for 48.89 percent of all cancer deaths. To better effect a program of stomach cancer prevention and control, and to protect the health of the Tibetan people, more than 20 medical workers from various local hospitals in Rikaze, Shannan and Lhasa, and the garrison hospital met and based their operation at the autonomous region's People's Hospital, and formed small groups to conduct a stomach cancer survey of the region. Given special funding and special medical equipment, they began their work in mid-April.

Selected as targets of the comprehensive survey were cadres and residents of various national minority groups in the city of Lhasa--the area with the highest incidence of stomach cancer in Tibet (stomach cancer mortality rate at 34.76 per 100,000). The general examination included an endoscopic examination and biopsy of stomach lining, and for certain individuals, a barium meal study. After a period of more than 2 months, a total of 1,234 persons, representing cadres, workers, peasants, residents, Army personnel and students of various minority groups had been examined. The results showed a 2.19 percent incidence of stomach cancer, with early cancer comprising 11.1 percent of those found positive. The incidence for duodenal cancer was 8.18 percent; for chronic atrophic gastritis, 15.5 percent; and for stomach polyps, 1.7 percent. Stomach cancer patients were hospitalized for surgery; other stomach conditions were treated accordingly. This comprehensive survey showed the incidence rates of stomach cancer and precancerous conditions in Tibet were markedly higher than that found in other provincial districts.

5292

CSO: 4008/216

LIFE SCIENCES

ADVANCES IN DIVING MEDICINE RESEARCH BEING MADE

Beijing GUANGMING RIBAO in Chinese 17 Aug 82 p 1

[Article by reporters He Yi [6320 3015], Song Guangming [1345 0342 2494], and Zhao Yuelong [6392 1471 7893]]

[Text] At the recent Conference on Naval Construction for Progress, delegate and researcher Gong Jinhua [7895 6930 3211] of the Institute of Naval Medicine was cited for his painstaking work in diving medicine that has catapulted China's contributions to advanced international levels, and honored as a vanguard of socialist intellectual progress.

Gong, now 55 years old, graduated from the Tongji University Medical College during the early years of the Liberation, and decided then to concentrate on research in diving medicine. On 12 May 1963 then Premier Chou Enlai visited his compression chamber laboratory to inspect his research firsthand and showed great personal interest that made Gong even more determined to dedicate his life to this work. To find a method for treating decompression sickness and to systematically study specialized knowledge on diving medicine, Gong went to several large libraries in search of related data. He spent several months of his spare-time at a library going through a specialty index comprising several hundred titles gleaned from international journals, classified and abstracted relevant articles, and compiled a special bibliography on diving medicine with appropriate sub-headings into specific subject areas. At other times, after perusing journal articles, he would write up "literature reviews." At present, he has already written 35 reviews totaling more than 600,000 words. He has also compiled over 2,000 valuable data cards, and kept voluminous notes. Over the years, his wealth of medical knowledge has surfaced in medical articles, translations, and teaching material.

In 1962, Gong simply applied pressure and cured a patient who had had decompression sickness for 136 hours. The following year, he successfully treated another diver who had been ill for over 2 years. In 1964, after much thought and review, he proposed the new concept of "chronic decompression sickness." At present, 101 cases of chronic decompression sickness have been successfully treated at his laboratory--the patient with the longest medical history had been ill for over 10 years, 80 patients were cured, comprising 79 percent of those treated; 21 showed marked improvement,

comprising 21 percent. This fact has revised the theory, proposed in foreign literature, that states that for cases of decompression sickness lasting more than 24 to 72 hours, the chances for recovery are remote. Gong's concept has created a new avenue of treatment for decompression sickness, both in theory and practice.

Though Gong Jinhan is in poor health, he has continued working. Once, after he was hospitalized for a coronary attack and given a month's rest, he plunged into intense preparations for a scholarly conference. This March, when several organizational units were jointly testing some imported diving equipment, and conducting a 200-meter helium-oxygen saturation diving test, he boarded the monitoring ship after his Beijing meeting was over, and chose to direct the safety of the exercise on site. During those days of intensive training, he only slept 9 hours in a 4-day period, even though colleagues were very concerned about his health. It was through such diligence and cooperation with others that this long and difficult training exercise and trial succeeded.

5292

CSO: 4008/216

Automation

AUTHOR: ZHANG Xinzhong [1728 3512 0022]  
XIA Ying [1115 3853]  
HE Kezhong [0149 0344 1813]

ORG: All of Qinghua University

TITLE: "A Precise Chinese Character Phototypesetting System"

SOURCE: Beijing ZIDONGHUA XUEBAO [ACTA AUTOMATICA SINICA] in Chinese No 4, 1982  
pp 257-263

TEXT OF ENGLISH ABSTRACT: A precise Chinese character phototypesetting system controlled by a computer is presented. It consists of a big keyboard of Chinese characters, automatic phototypesetting machine and a check system consisting of a Chinese character generator and a laser scanning dot-matrix printer. The Chinese character generator is composed of 32 x 32 dot-matrix implemented with an E-shape soft magnetic core.

In order to guarantee the quality of characters and page format, to have a higher speed of phototypesetting and to make full use of the large difference in the frequency of usage of Chinese characters, the working principle of this automatic phototypesetting machine is to focus the image of all Chinese typeheads at different positions on the model plate into a small square by means of one big lens and several hundred small lenses.

[Continuation of ZIDONGHUA XUEBAO No 4, 1982 pp 257-263]

This machine has four typefaces: Song-dynasty-style typeface, imitation Song-dynasty-style typeface, blackface type and regular script. There are 10 sizes and 7 shapes for each typeface so that the machine may be considered as consisting of about 2 million typecasts.

9717  
CSO: 4009/36

AUTHOR: None

ORG: None

TITLE: "Control Theory Committee of China Automation Society Held the 3rd National Symposium on Control Theory and Its Applications"

SOURCE: Beijing ZIDONGHUA XUEBAO [ACTA AUTOMATICA SINICA] in Chinese No 4, Oct 82 p 120

ABSTRACT: On 15-21 May 82, the 3rd National Symposium on Control Theory and Its Applications, sponsored by the Control Theory Committee of China Automation Society was held in Sichuan Province. There were 100 official delegates and 47 alternates, representing more than 90 organizations all over the country. The delegates were divided into 4 groups to listen to and discuss 81 papers; 3 teams were organized to introduce foreign researches on control theory and other special subject reports. A quarter of the papers delivered this time concern applications of the control theory in petroleum mining and production forecasting, space navigation, aeronautic industry, manufacturing of precision instruments, automation of production processes, biomedical fields, socioeconomic control, etc. Of the 81 papers, one third are written and delivered by young scientists, representing continuous emergence of new manpower in the field. The symposium resolved to call upon related organizations and departments to create favorable conditions for scientists to carry out theoretical researches on application, on simpler and effective methods of computation, on making softwares generally applicable, and on the gradual perfection of program designing and application, for the purpose of promoting the application of modern control theory.

6168

CSO: 4009/36

Metallurgy

AUTHOR: LU Zulian [7120 4371 1670]

ORG: Shoudu Iron and Steel Company

TITLE: "The Practice of Increasing the Productivity of Shoudu BOF Plant"

SOURCE: Beijing GANGTIE [IRON AND STEEL] in Chinese No 9, 1982 pp 18-24, 70

TEXT OF ENGLISH ABSTRACT: The BOF plant of Shoudu Iron and Steel Company, equipped with three 30-ton vessels, has kept to achieving over 4000 heats annually since 1978. In this article, a description of the principle observed for raising productivity and some special measures taken by the plant are given. Emphasis is made on the quality and stability of raw materials, smoothness and reproducibility of operations, scientific operating system which is chosen in the light of the plant's conditions to get comprehensive economic results, and full development of every operator's sense of responsibility so as to ensure every step in the operation being correct.

AUTHOR: FU Zuobao [0265 0155 1405]

ORG: Cold Rolling Works of Anshan Iron and Steel Company

TITLE: "The Improvement of Production Technique of Cold Rolled Deep Drawing Sheet for Automotive Industry"

SOURCE: Beijing GANGTIE [IRON AND STEEL] in Chinese No 9, 1982 pp 25-29, 44

TEXT OF ENGLISH ABSTRACT: For the purpose of improving the deep drawing properties of automobile body sheet, according to YB 215-64 standards, three major decisive production processes in the whole procedure of production were studied and improved by our work (such as steel quality, hot rolling and cold rolling). It is considered that the steel quality is the foundation in hot rolling and three high and one low is the premise (higher heating temperature, higher rolling temperature, higher finishing temperature and lower coiling temperature); whereas in cold rolling, stable rate of reduction, two-step annealing and shot blasted roll surface are the more reasonable technical regulations. Very good results were obtained in production.

9717

CSO: 4009/35

AUTHOR: None

ORG: Office of Rare Earth Metallurgy

TITLE: "The 2nd Symposium on the Use of Rare Earth Metals in Cast Iron and Cast Steel Held by the Ministry of Metallurgical Industry"

SOURCE: Beijing GANGTIE [IRON AND STEEL] in Chinese No 9, Sep 82 pp 75-76

ABSTRACT: On 24-27 Apr 82, the Ministry of Metallurgical Industry held its 2nd Symposium on the application of rare-earth elements in cast iron and steel for the purpose of exchanging the experiences of the past year, examining conditions of implementation of research plans, and discussing the development schemes prior to 1985. This symposium in Beijing was attended by 102 delegates representing 44 organizations. Since the 1st symposium, held in Dec 80, some progresses have been made in the field, including the rare earth magnesium nodular cast iron and steel ingot molds. Practices of long periods of time in Shanghai Bureau of Metallurgy, Qiqihar Steel Mill, etc. have proved that using this material can reduce 3-5 kg of mold consumption per ton of steel ingots, on the average. Techniques of using rare earth in metallurgical rollers and casting pipes have also been developed with obvious results of savings. These and other achievements are among the subjects discussed at the meetings and in the 27 papers received by the symposium. At present, problems concerning low temperature and high sulfur content of molten iron are being studied with emphasis at several organizations and investment capital is being arranged to reconstruct related equipment so as to extend the use of rare earth elements in metallurgy. Cooperative relationship among the related organizations is clarified along with research plans of the years before 1985.

AUTHOR: WANG Hanming [3076 3352 2494]

ORG: None

TITLE: "Symposium on the Reconstruction of Seamless Tube Rolling Mills"

SOURCE: Beijing GANGTIE [IRON AND STEEL] in Chinese No 9, Sep 82 p 78

ABSTRACT: On 1-6 Jun 82, a symposium on techniques of reconstructing small machines of seamless tube rolling mills, under the auspices of the Seamless Steel Tube Specialty Group of Steel Rolling Committee of China Society of Metals. Participants included 65 delegates representing 36 units of seamless steel tube producing mills, institutes of higher education and research, and designing departments. The objective of the symposium is to investigate the direction of reconstruction of China's 76,100 seamless tube machines, to discuss concrete reconstruction schemes and measures to improve the quality of the products and to raise the economic benefits, and to find ways of expanding the type of products while reducing the consumption of materials. During the symposium, papers and speeches were delivered by 16 delegates. Finally, it is resolved to suggest that a nationwide steel tube research center should be established and that related departments of the Ministry of Metallurgy should organize manpower and materials to accelerate the study and application of some new techniques for reducing tensile stress, diagonal rolling, continuous rolling, etc.

6248

CSO: 4009/35

END