

# NAVAL POSTGRADUATE SCHOOL Monterey, California



## A Fuzzy Associative Data Fusion Algorithm for VTS

by

Murali Tummala  
Sean A. Midwood

January 27, 1998

19980311 115

**DTIC QUALITY INSPECTED 3**

Approved for public release; distribution is unlimited.

Prepared for: U.S. Coast Guard  
Command Control Engineering Center

NAVAL POSTGRADUATE SCHOOL  
Monterey, California

Rear Admiral M.J. Evans  
Superintendent

R. Elster  
Provost

This report was sponsored by the U.S. Coast Guard Command Control Engineering Center.

Approved for public release; distribution is unlimited.

The report was prepared by:

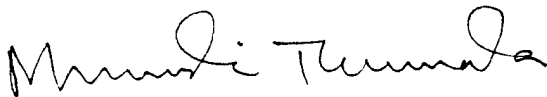

Murali Tummala  
Professor  
Department of Electrical and  
Computer Engineering

Reviewed by:

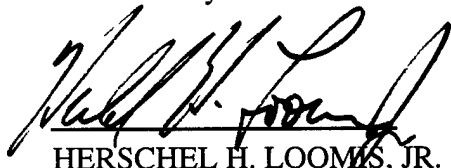

HERSCHEL H. LOOMIS, JR.  
Chairman  
Department of Electrical and  
Computer Engineering

Released by:

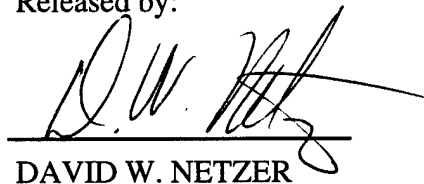

DAVID W. NETZER  
Associate Provost and  
Dean of Research

**REPORT DOCUMENTATION PAGE**Form Approved  
OMB No. 0704-0188

Public reporting burden for the collection of information is estimated to average 1 hour per response, including the time for reviewing instructions, searching existing data sources, gathering and maintaining the data needed, and completing and reviewing the collection of information. Send comments regarding this burden estimate or any other aspect of this collection of information, including suggestions for reducing this burden to Washington Headquarters Services, Directorate for Information Operations and Reports, 1215 Jefferson Davis Highway, Suite 1204, Arlington VA 22202-4302, and to the Office of Management and Budget, Paperwork Reduction Project (0704-0188), Washington DC 20503.

1. AGENCY USE ONLY (Leave blank)	2. REPORT DATE January 27, 1998	3. REPORT TYPE AND DATES COVERED Interim Report 1 Jan-30 Sep 1997	
4. TITLE AND SUBTITLE A Fuzzy Associative Data Fusion Algorithm for VTS		5. FUNDING NUMBERS N6600197WR00229	
6. AUTHOR(S) Murali Tummala and Sean A. Midwood			
7. PERFORMING ORGANIZATION NAME(S) AND ADDRESS(ES) Department of Electrical and Computer Engineering Naval Postgraduate School Monterey, CA 93943-5000		8. PERFORMING ORGANIZATION REPORT NUMBER NPS-EC-98-004	
9. SPONSORING/MONITORING AGENCY NAME(S) AND ADDRESS(ES) U.S. Coast Guard Command Control Engineering Center 4000 Coast Guard Blvd. Portsmouth, VA 23703-2199		10. SPONSORING/MONITORING AGENCY REPORT NUMBER	
11. SUPPLEMENTARY NOTES The views expressed in this report are those of the author and do not reflect the official policy or position of the Department of Defense or the United States Government.			
12a. DISTRIBUTION/AVAILABILITY STATEMENT Approved for public release; distribution is unlimited.		12b. DISTRIBUTION CODE A	
13. ABSTRACT (Maximum 200 words)  An algorithm to fuse redundant observations due to multiple sensor coverage, in order to reduce duplicate track information provided to Vessel Traffic Services (VTS) operator displays, is reported. The algorithm receives inputs from multiple sensors as long as the basic decision criteria elements are provided. The algorithm is tested with real data collected from the VTS system at Puget Sound in September 1996. The results indicate that the algorithm correctly fuses redundant sensor observations on the same vessel resulting in a significant reduction in the amount of unnecessary information presented to the VTS operator.			
14. SUBJECT TERMS Vessel traffic system, fuzzy logic, data fusion, multiple sensors		15. NUMBER OF PAGES 25	16. PRICE CODE
17. SECURITY CLASSIFICATION OF REPORT UNCLASSIFIED	18. SECURITY CLASSIFICATION OF THIS PAGE UNCLASSIFIED	19. SECURITY CLASSIFICATION OF ABSTRACT UNCLASSIFIED	20. LIMITATION OF ABSTRACT SAR

## ABSTRACT

An algorithm to fuse redundant observations due to multiple sensor coverage, in order to reduce duplicate track information provided to Vessel Traffic Services (VTS) operator displays, is reported. The algorithm receives inputs from multiple sensors as long as the basic decision criteria elements are provided. The algorithm is tested with real data collected from the VTS system at Puget Sound in September 1996. The results indicate that the algorithm correctly fuses redundant sensor observations on the same vessel resulting in a significant reduction in the amount of unnecessary information presented to the VTS operator.

## 1. INTRODUCTION

At a given Vessel Traffic Center (VTC), the sensor reports are plotted as tracks on a display, layered over raw radar video, which is used by system operators to provide advisories to vessels that promotes a safe and efficient operating environment. The version of software currently employed by the Vessel Traffic Services (VTS) is not capable of correlating redundant reports on the same vessel that are provided by the various sensors in the system. These duplicate tracks, which appear on the VTS displays, are a significant system deficiency that detracts from an operator's ability to manage overall waterway safety.

This report presents a proof-of concept algorithm that will perform multisensor data fusion on the sensor information currently provided on vessels in a VTS System. The results are output as a unique set of tracks to an operator display and archived. The algorithm takes data from any available sensor that can provide the necessary attributes in order to make a fusion decision. Unlike the previous work [Ref. 1, 2], actual data from an operational VTS System was obtained for testing and development of the algorithm.

An introduction to the VTS environment and overall system description is provided in Section 2. In Section 3, data collection, formatting are discussed. The discussion of the algorithm, its development and component parts are found in Section 4 while the actual results are reported in Section 5. The algorithm is implemented using the MALAB® package, and a listing of the code is available in [Ref. 1].

## 2. THE VTS ENVIRONMENT

The VTS system is a module of the Joint Maritime Command Information System (JMCIS). The current configuration of the VTS system is based on the Unified Build (UB) Software Development Environment (SDE) Track Database Manager (Tdbm) Service [Ref. 2, 3].

The data is obtained from multiple sensors: radar, Automated Dependent Surveillance (ADS) and synthetic, and/or Standard Routes (SR). The radar tracks are provided by commercially available radar sets. The need for a data fusion scheme within the VTS system has been clearly identified for the overlapping radar coverage scenario. ADS tracks are Global Positioning System (GPS) or Differential GPS (DGPS) based information sent automatically via radio link from the vessel. It will provide a greater reporting redundancy, thus even more uncorrelated tracks to the

operator displays. SR tracks based on the last known position, course and speed of the vessel are synthetically generated within the VTS system by operator intervention. These are available to the operator should the vessel in question have a non-reporting status from any of the system's other sensors. The resulting quantity of redundant information continuously provided to operator displays is a serious deficiency which the proposed fusion scheme seeks to address.

The VTS system is, for all practicable purposes, JMCIS with all correlation functions but Link Correlation disabled. The VTS system does not use four of the five correlation functions of the JMCIS system. It is configured this way to ensure that the one-to-one association between a link track and a platform track is never severed. However, it prevents the VTS system from being able to perform many-to-one or redundant link track associations to one platform track. The fusion algorithm proposed here will make these many-to-one associations as quickly and as transparently as possible, allowing the operator to focus on overall vessel traffic management as opposed to managing multiple incidences of the same vessel.

Figure 1 [Ref. 2] is a representation of the JMCIS software architecture, and the fusion algorithm could be introduced as a part of the Correlator. As tracks are reported into the Tdbm, each one is sent through the Correlator in order to promote it to an existing platform track (report from the same RSP with an identical track number) or generate a new platform track. At this point the fusion algorithm would examine the link tracks resident within the Tdbm and determine whether any redundancy in reporting had occurred. The algorithm would then output a unique set of platform tracks where one-to-one (unique track) and many-to-one (redundant reports from multiple sensors on the same vessel) promotions had been accomplished.

## **2.1 Radar Tracks**

The radar processor incorporates a sliding window detection algorithm which integrates hit data over the antenna beamwidth. It uses leading and trailing edge confidence count criteria to extract targets to achieve the CFAR (system default is  $10E-5$ ) set by the operator [Ref. 4]. A Confidence Count (CC) is performed to determine if the required number of hits occurred to declare a valid plot. The fusion algorithm assumes that the system parameters have been optimized for the current operating conditions and that valid tracks are being reported to the VTC's Tdbm. [Ref. 2]

The following information is sent to the Tdbm from the RSP via a microwave or fiber optic communications link [Ref. 5]: Site Number (Sensor identification); Track Number; Time of Track

Position (UTC); Course in Degrees; Speed in Knots (KTS); Predicted Range in Nautical Miles (NM); Predicted Azimuth; Radar Range in NM; Radar Azimuth; Extent Range in NM; Extent Azimuth; Track Quality (low of 4 to high of 9 ); Acquisition Mode ( Automatic - A, Manual - M); Lost Track (Set after a predetermined number of Coast Tracks have occurred); and Coast Track (Indicates no hit on last scan).

## 2.2 Automated Dependent Surveillance (ADS) Tracks

The GPS based ADS segment is currently being integrated into the Vessel Traffic Services (VTS) System Expansion program [Ref. 6] (see Figure 2). GPS Standard Positioning Service (SPS) is a slightly degraded GPS (accurate to 100 meters) signal available worldwide at no cost to any user who wants it. Differential GPS (DGPS) is a USCG program to realize a 10-meter accuracy from the GPS SPS by furnishing signal corrections to properly equipped users [Ref. 5].

The ADS segment will provide GPS and DGPS tracking capability to the VTS system. The inherent accuracy of GPS based systems [Ref. 5], their relatively low cost and almost universal presence will make ADS a key component of the VTS system in the near future. ADS information is sent, from the vessel itself, to the VTC over a satellite or Digital Selective Calling (DSC) data link. The National Marine Electronics Association (NMEA) 0183 Standard is used to report ADS

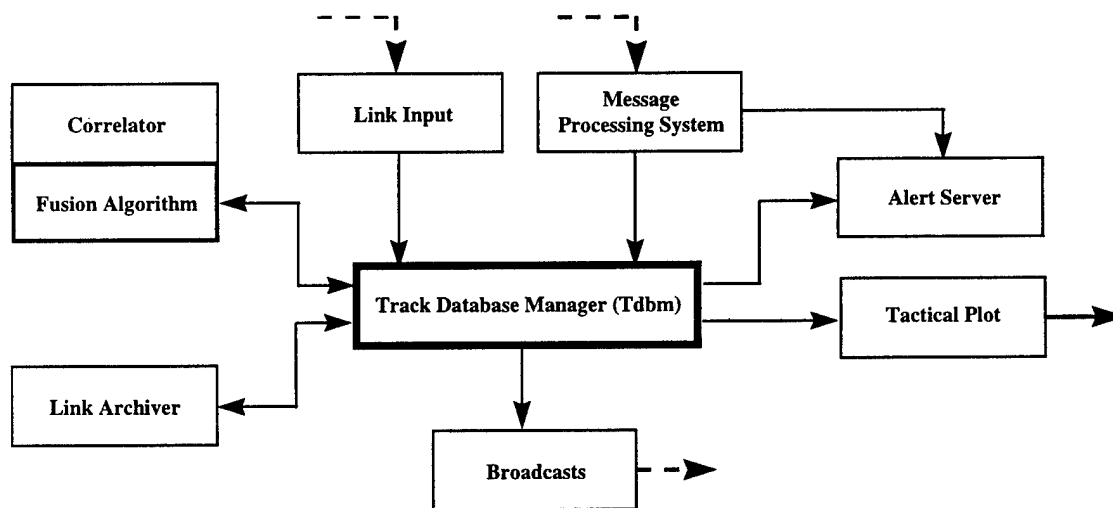

Figure 1. JMCIS Software Architecture

tracks into the system. This "Voiceless VTS" data stream provides all required information in order to build a track history within the Tdbm [Ref. 4]. The following information, on ADS tracks, is available to the fusion algorithm: Vessel Name; UTC; Tracking Status (e.g., Radar, ADS, SR);

Track I.D. (Track Number); Sensor Track Number (e.g., Radar Track Number or SR Number); Course (True Course in degrees); Speed (Knots Over the Ground); Latitude; Longitude; Size (Length) of Vessel; and Track Quality.

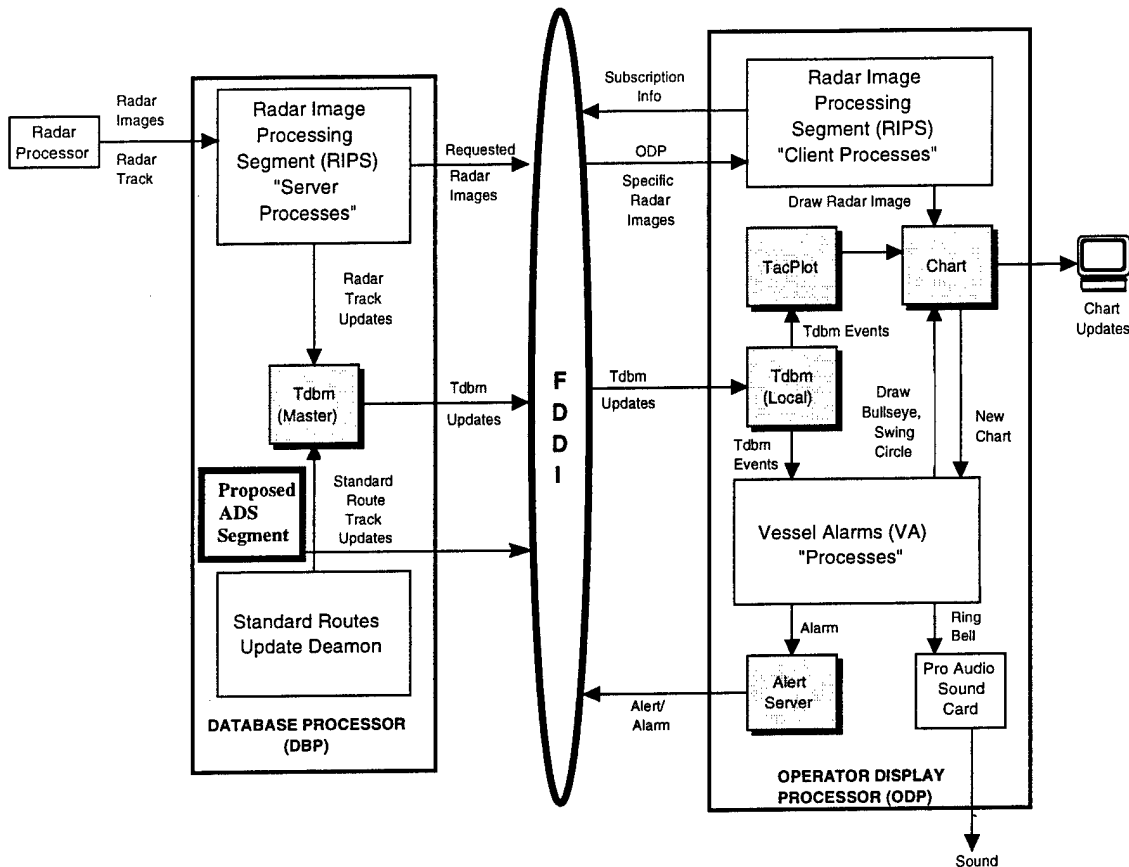

Figure 2. Proposed ADS Segment

### 2.3 Standard Route (SR) Tracks

The SR represent an Estimated Position (EP) of the vessel of interest through a VTC's Area of Responsibility (AOR). SRs are generated by the SR daemon, and the system can be configured for automatic or manual generation. When a radar track is lost on a vessel, an SR is initiated to help estimate the position of the vessel as it transits the AOR. These SRs are multisegmented predefined routes that are geographically fixed to represent the waterway under consideration. These routes are assigned based on the type of vessel and initial position, and vectoring is derived from the track information last reported into the Tdbm. The predicted path of the vessel is then updated every ten seconds into the Tdbm and closely monitored and manually updated as deemed necessary. The SR is terminated once the original or another sensor acquires the track. There is no association between



radar and SR tracks and it takes a great deal of operator experience and intuition to generate a reasonable approximation of a vessel's route. [Ref. 2]

### 3. DATA COLLECTION, FORMATTING, AND PREPROCESSING

The data used to test the algorithm was collected over a two day period, September 11-12, 1996, at the Puget Sound VTC. Conditions for the data collection were satisfactory, and data sets were rich with multiple sensors, primarily radar and ADS, reporting on the same target. Portable ADS equipment was set up on selected Washington state ferries whose routes and schedules were well known to the VTS system operators. Track history recording was conducted in accordance with [Ref. 7] and on a non-interference basis with normal VTC operations. Up to 10 tracks were available for simultaneous track history recording for up to 12 hours in duration. All parameters except Track Quality (TC) were correctly reported into the system and archived.

Post analysis of the data showed that there was enough variety in the scenarios and sufficient redundancy in sensor reports to thoroughly test the fusion algorithm. Due to the limited number of tracks that could be recorded, emphasis was placed on ADS and radar data; no SR track scenarios were collected. The track histories were stored in ASCII files and the data was recorded for each selected track in the following format [Ref. 6]:

Name: track-history.dat										
Path: /h/data/local/ADS										
Format:										
<b>1</b>	<b>2</b>	<b>3</b>	<b>4</b>	<b>5</b>	<b>6</b>	<b>7</b>	<b>8</b>	<b>9</b>	<b>10</b>	<b>11</b>
cccc	DDMMY Yhhmmss	AAA	cccc	cccc	x.x	x.x	ddmm.mm	ddmm.mm	size	x<CR>
cccc	DDMMY Yhhmmss	AAA	cccc	cccc	x.x	x.x	ddmm.mm	ddmm.mm	size	x<CR>
etc.										
<b>1</b>	26cc	Vessel Name								
<b>2</b>	DDMMYYhhmmss	UTC—Time of Track Position								
<b>3</b>	AAA	Track Status (Radar, SR, ADS)								
<b>4</b>	cccc	Track ID								
<b>5</b>	cccc	Sensor Track #—Radar # and Track # or CID # or SR #								
<b>6</b>	x.x	True Course								
<b>7</b>	x.x	Speed (knots over ground)								
<b>8</b>	ddmm.mm	Latitude—degrees   minutes								
<b>9</b>	ddmm.mm	Longitude—degrees   minutes								
<b>10</b>	#	Size of Vessel								
<b>11</b>	x	Track Quality (good, coast, lost for Radar; 0, Non-Diff, Diff for ADS)								

A sample of the contents of a recorded track file is shown below:

```
UNK-4743,110996212055,Radar,742,3,180.4,5.9,4735.08,-12228.05,0,0
UNK-4754,110996212055,Radar,753,3,186.6,5.1,4735.54,-12227.82,0,0
UNK-4773,110996212052,Radar,772,3,93.4,18.0,4736.41,-12228.42,0,0
SPOKANE_ADS,110996212023,ADS,773,3669994520,92.7,18.0,4736.37,-12228.66,0,0
SPOKANE_ADS,110996212056,ADS,773,3669994520,93.2,18.3,4736.36,-12228.41,0,0
SPOKANE_ADS,110996212056,ADS,773,3669994520,93.2,18.3,4736.36,-12228.41,0,0
UNK-4751,110996212058,Radar,750,3,357.7,8.9,4738.47,-12226.49,0,0
UNK-4756,110996212058,Radar,755,3,195.2,9.2,4734.51,-12228.03,0,0
UNK-4773,110996212058,Radar,772,3,91.9,18.1,4736.41,-12228.38,0,0
```

A vessel's name is identified in column one as unknown (UNK-XXXX) if the true identity has not been determined. Column three indicates sensor type.

### 3.1 Preprocessing

The data files were recorded in ASCII comma-delimited format. The following procedure was followed to build data files: open the ASCII file in the word processor of choice [Microsoft Word® in this case]; cut and paste the desired length of data into a new file, then use the Save As menu choice and name the file with a *.dat* extension. [e.g., *11\_e1.dat*]; and perform a global search and replace on Track Status, changing Radar to "1," ADS to "2" and SR to "3."

Once these files were built, a set of functions were developed to read them into MATLAB® and emulate what the data would look like to the fusion algorithm within the Tdbm. To accomplish this, the data were placed in a matrix called *ObsnMatrix*. The data from the individual fields are placed in their respective storage vectors. They are then appended together to form the observation matrix *ObsnMatrix*. The contents of the matrix are easily discerned via their descriptive names: **ObsnMatrix = [Latitude, Longitude, TrueCourse, Speed, Size, TrackIDNumber, UTC, TrackQuality, TrackStatus, SensorTrackNumber]**. The data is now ready to be input to the fusion algorithm as if it were available in real time.

## 4. FUSION ALGORITHM

This section examines the fusion algorithm in detail (see Figure 3) and describes the fuzzy association techniques that are employed to provide a possible solution to the growing track redundancy problem within the VTS System. Data windowing (prior to the fusion algorithm) and multisensor data fusion, in general terms, are as well.

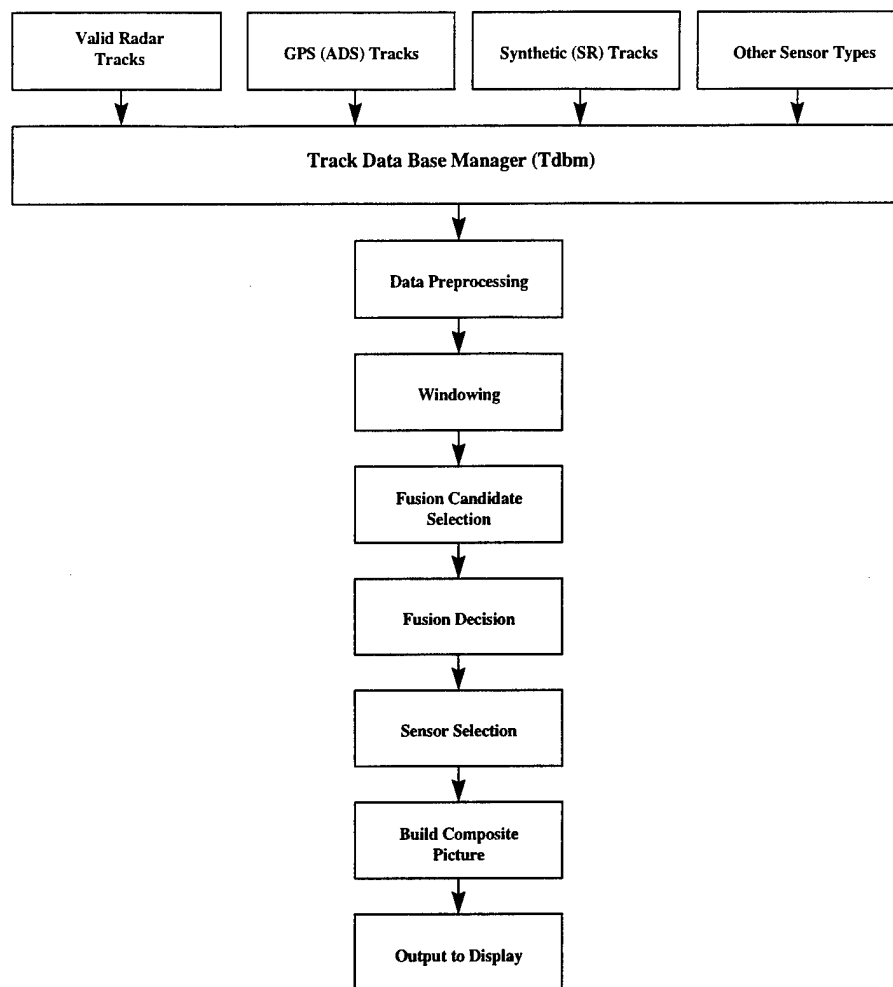

Figure 3. Overview of Fusion Algorithm

#### 4.1 Windowing of Data

A time window operation is applied to the data once it is made available to the algorithm from the Tdbm. The windowed observations are placed in a refined observation matrix called *WindowedObsns* to await possible further data set reduction. The actual length of the window depends strictly on update rates from the various sensors and the relative change in position of a track between updates. In the case of the VTS System, radar tracks are updated every six seconds, SR tracks every ten seconds and ADS tracks every 15 seconds. Vessel speeds vary from zero to twenty knots with the majority of vessels making good around eight knots.

Given the relatively slow change of position of the vessels and the fast update rates of the sensors, it is readily apparent that the tracks are over sampled for this application. A window size

of 15 seconds would ensure an opportunity for all sensor types to report thus addressing any latency issues for the current system configuration. The VTS System does not require that positions be updated this quickly; therefore, it is possible to substantially reduce the processing load by optimizing the window size to obtain a satisfactory update rate.

After the window has been applied, the algorithm selects the most recent track from *WindowedObsns* and places them in a reduced observation matrix called *MostRecentTrks*. The data set is now reduced to the desired content and can be input to the fusion algorithm.

#### **4.2 Multisensor Data Fusion**

The primary goal of the fusion algorithm is to fuse together observations from different sensors made on the same target or vessel. The reporting sensor can be of any type as long as it provides the necessary information upon which fusion decisions are made. Here, reports are available from radar, ADS and SR mechanisms. Inclusion of additional sensors (e.g., acoustic sensors positioned in critical waterways) can be readily achieved in future versions of the algorithm. The fused tracks are assigned a platform number for output to the operator displays, with the superior sensor assigned reporting responsibility. The information from inferior sensors is suppressed, but not decimated, resulting in a more clear picture of what is occurring in the waterways and harbors via operator displays. This fusion process is achieved through the use of fuzzy membership functions that determine the level of correlation between the set of observations from different sensors.

The proposed algorithm attempts to accomplish fusion by specifying rules that help in making decisions [Ref. 8]. The algorithm associates redundant tracks for same vessel which are reported into the system from the various system sensors. This association is performed by the membership functions that measure the level of similarity between a set of observations. These values of "sameness" are then used in the fusion process for decision making (threshold setting) and track identification. The output can be visualized by taking a combination of data, from different sources, to obtain a refined location and identity estimation on the target [Ref. 9].

#### **4.3 Positional Fusion [Ref. 10]**

The reporting sensors in the VTS System have already performed positional or sensor level fusion prior to initiating a report to the Tdbm. In the case of radar, it is a function of the pairing, developing and maturing sequence (see Section 2); where as for ADS and SR reports, it is physically impossible to have overlapping coverage on a vessel. The VTS system assumes that

sensor level fusion is being carried out correctly and only valid, non-redundant tracks are being generated and reported by individual sensors. [Ref. 2]

Once the valid tracks are in the Tdbm, central level positional fusion is carried out to eliminate the redundancies that occur from different sensors reporting on the same track. This is not database fusion as the algorithm does not destroy or alter any information about a target even though a fusion decision may have been made. The output from the inferior redundant sensors is simply suppressed and not routed to the displays. This approach was taken to ensure that the system could take advantage of track redundancy as represented by the suppressed information. This suppressed information would be utilized if the reporting sensor on a fused track ceases to report and a hand off to the next superior sensor becomes necessary. The other obvious case is when a decision is made to defuse. Additionally, having this information available for ready recall helps in the analysis of the system to ensure optimum performance.

#### **4.4 Fusion Process**

The algorithm (see Figure 4) now takes the reduced data set resident in the matrix *MostRecentTrks* and begins the fusion process. It accomplishes this by sequentially comparing track pairs in order to determine the grade of membership between the attributes that are used in the fusion decision process. The attributes used in the decision process are *Latitude*, *Longitude*, *Course* and *Speed*. Originally, vessel *Size* and *TrackQuality* were to be included but their utility was marginalized by the methods used to record their values into the system during data collection. If deemed necessary, these or any other suitable attributes can be readily added in the future due to the modular approach used to construct the code.

The assignment of membership value that is accomplished by the fuzzy association system is a measure of similarity or sameness by correlation [Ref. 2]. Membership functions are used to grade the attributes of a set usually in the range [0,1]. The closer the attribute is graded to the upper bound, the higher the grade of membership. The higher the grade the attribute is assigned, the more similar it is to the attribute it is being compared against. Instead of answering the question with a crisp or simple YES or NO, it provides a scaled interpretive answer which can be NOT LIKE, A BIT LIKE, SOMEWHAT LIKE, A LOT LIKE, or LIKE. This type of answer is obviously a better representation of how VTS operators currently interpret about what is developing on their displays.

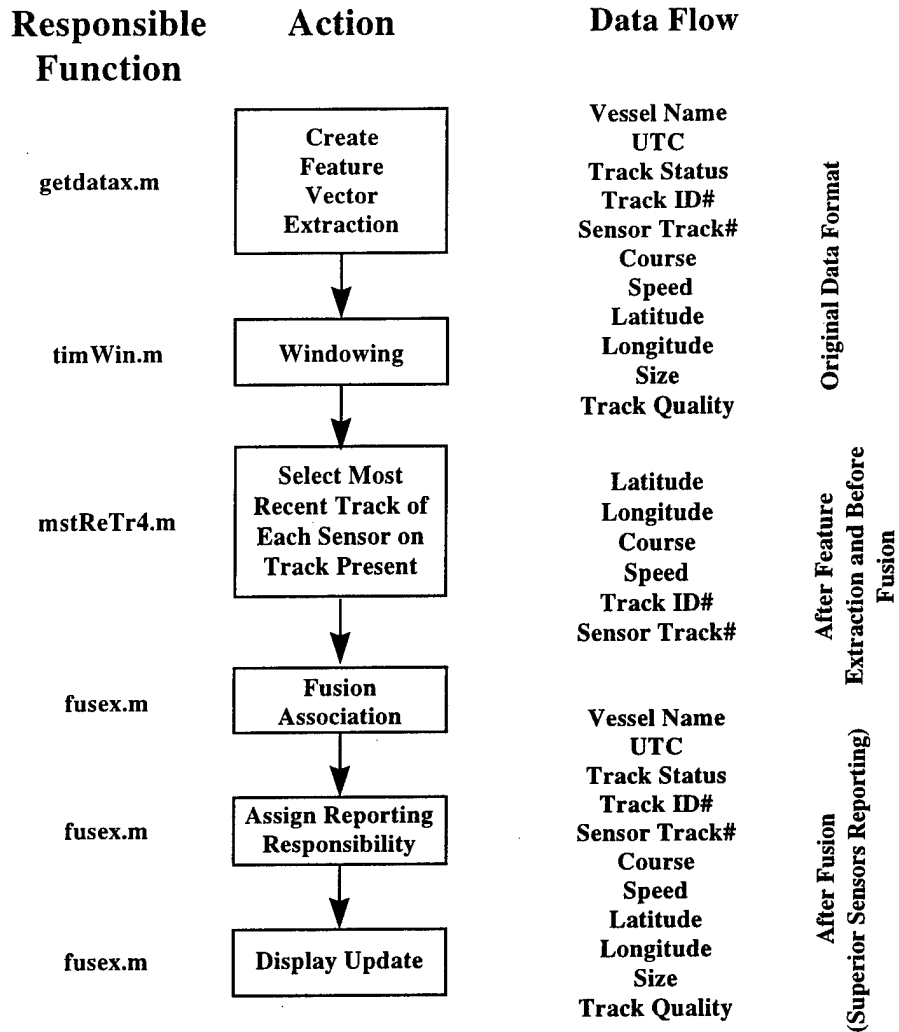

Figure 4. Flow Chart of the Fusion Algorithm

In the design of a fuzzy association system the following approach is used [Ref. 2, 11]: ascertain the universe of discourse of system input(s) and output(s); design the membership function(s); decide on the fuzzy rule(s) to relate input(s) and output(s); and devise the defuzzifying technique(s).

Membership function design is based on the variations inherent in an attribute that is being compared [Ref. 2]. Given that radar and ADS positional reports (i.e. latitude and longitude) are for the most part dependable and accurate, a form of triangular membership function is often used as shown in Figure 5. Whereas attributes that tend to be not quite as accurate (highly dependent on the type of sensor), such as speed, require a broadened roof as shown in Figure 5, which allows for a greater range of values. Combinations of these typical membership function shapes (e.g.,

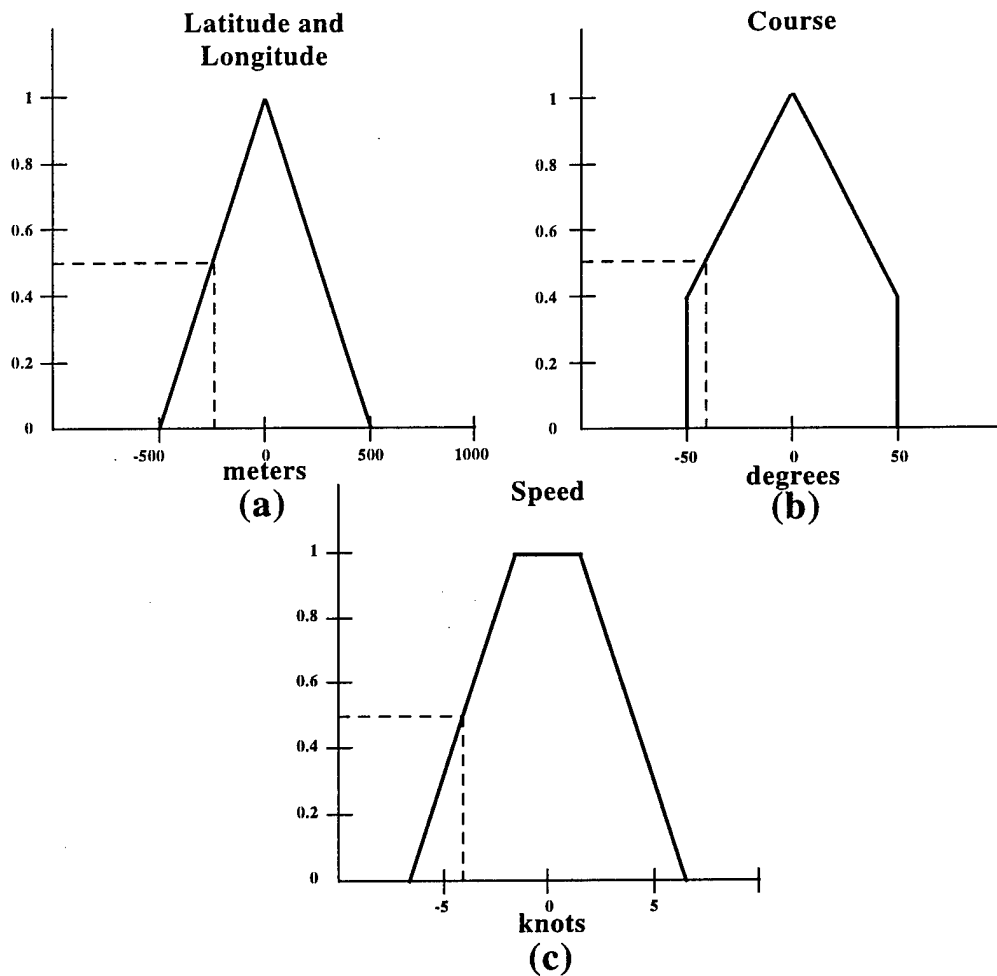

Figure 5. Membership Functions: (a) positional attributes - longitude and latitude; (b) course in degrees; and (c) speed in knots

trapezoidal) are useful, as in the case of the course attribute, where you desire a generous association within a certain range but not outside of a fixed range. Membership functions are by their very nature subjective, but they are far from arbitrary and need to be based on the application and the attribute in question. The relative shape of a membership function is only a starting point and follow up analysis of its performance is critical to fine tuning the process.

The next step is to evaluate all the attributes and their membership grade against a threshold value. This threshold value represents the known physical limitations or specifications of the sensor. In the case of a radar, it is based on bearing resolution, range resolution and speed error. For ADS, it is the relative accuracy of the measurements based on the type of the GPS being used.

With this diversity in the relative accuracy of sensor attributes, the threshold is always set based on the least accurate sensor.

With the thresholds set, the membership values of the attributes are checked in the following sequence: *Latitude*, *Longitude*, *Course* and *Speed*. Each attribute's membership value must exceed the threshold or the association fails for that track pair, and the algorithm proceeds to the next track pair and repeats the process. Track pair combinations that have all their attributes exceeding the threshold values are defuzzified and output as a virtual binary '1' as represented by their presence in a storage matrix called *FusionCandidates* (see Figure 6).

Once the *FusionCandidates* matrix is complete, the algorithm then performs an evaluation to determine what type of sensor is reporting and its location. This information is used to assign reporting responsibility to the superior sensor. The current hierarchy has radar at the top followed by ADS and SR in order of descending priority. Radar is currently given superior sensor status due

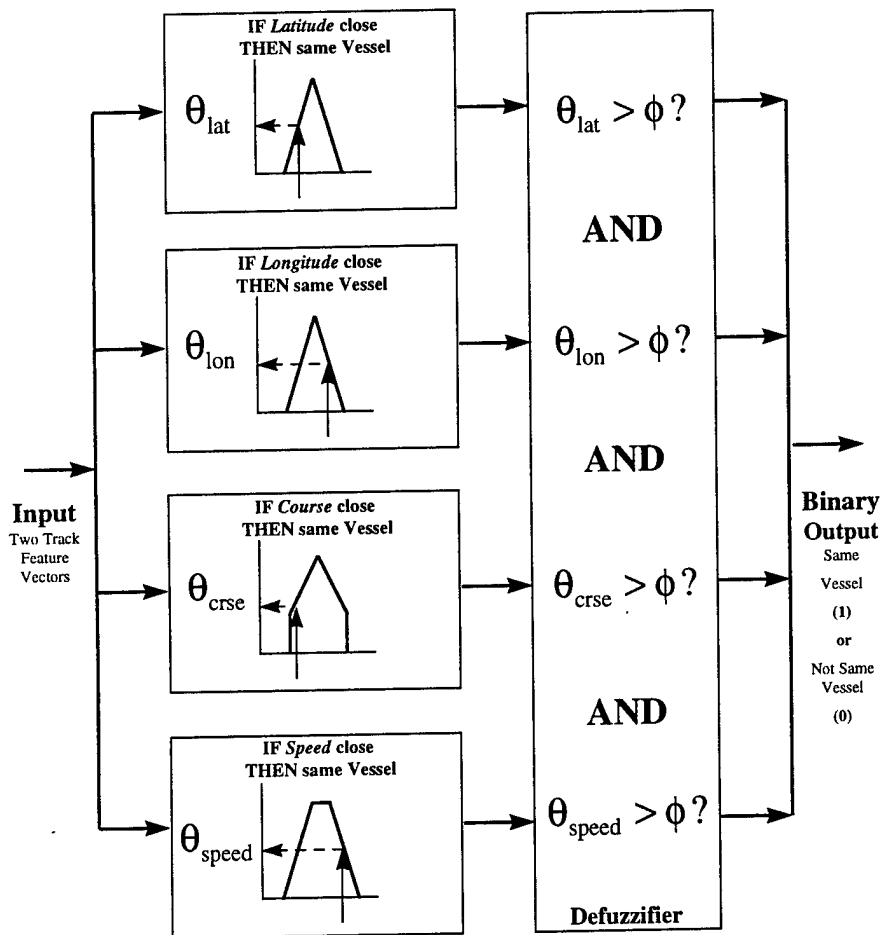

Figure 6. Depiction of the Fuzzy Associative Decision System



to the slow update rate of the ADS tracks. Once the update rates for ADS are at least comparable to radar update rates, ADS tracks will be assigned superior sensor status.

Should the redundancy in reporting be a consequence of the same type of sensor, it is necessary to select the superior of the two. In the case of radar tracks this is based on the characteristics of the radar; the radar possessing superior characteristics (resolution capabilities) is chosen. If the radars are similar, a designation within the system based on alternate criteria, such as current operating performance and relative distance to the target, would be used to select the superior sensor. The fusion algorithm is easily modified to accommodate any changes to sensor status. Same-type sensor redundancy is a radar issue exclusively as it is physically impossible to get multiple ADS and SR tracks on the same vessel. At this point the selected tracks that are being reported on by the superior sensors are placed in a matrix called *HitsToKeep*, and the tracks deemed redundant are placed in a matrix called *CeaseReport*.

#### **4.5 Report Generation and Output**

At this point it is necessary to include the tracks that were previously deemed not fuseable along with those that have been given reporting responsibility for the fused tracks. *HitsToKeep* is augmented with these lone tracks, and the matrix *UpdateReport* contains all the track numbers that need to be reported to the operator display.

The last step that needs to occur before updating the display is to take the track numbers from *UpdateReport* and extract all the track data from *MostRecentTrks* required for a complete report. For computational efficiency, all unnecessary data fields had been purged during the fusion process. *UpdateReport* is then checked for redundancy, sorted by track number and placed in the final output matrix *TrksToPlot*. An example of a typical plot of information display is depicted in Figure 7.

At this point the fusion cycle is complete. The superior sensors have been assigned reporting responsibility for tracks that had redundant or multiple sensor reports. The reports deemed redundant have had their output suppressed, and the system operator is now seeing only single realizations of vessel tracks. The data *window* is now moved forward in time in order to process the next set of sensor reports on tracks present in the system. The fusion operation is repeated in this manner until it is turned off.

## 5. RESULTS

Actual data from an operational VTS system was collected at Puget Sound in September 1996. This data allowed for thorough testing of the algorithm for a variety of real life scenarios depicting the redundancy issues faced by system operators with overlapping information from multiple radar and ADS tracks.

In order to build the data sets for demonstration, it was necessary to load a large amount of data with the fusion process turned off. The output to the display is a realization of what was occurring in the harbor and waterways during that time period. The display was then examined to determine

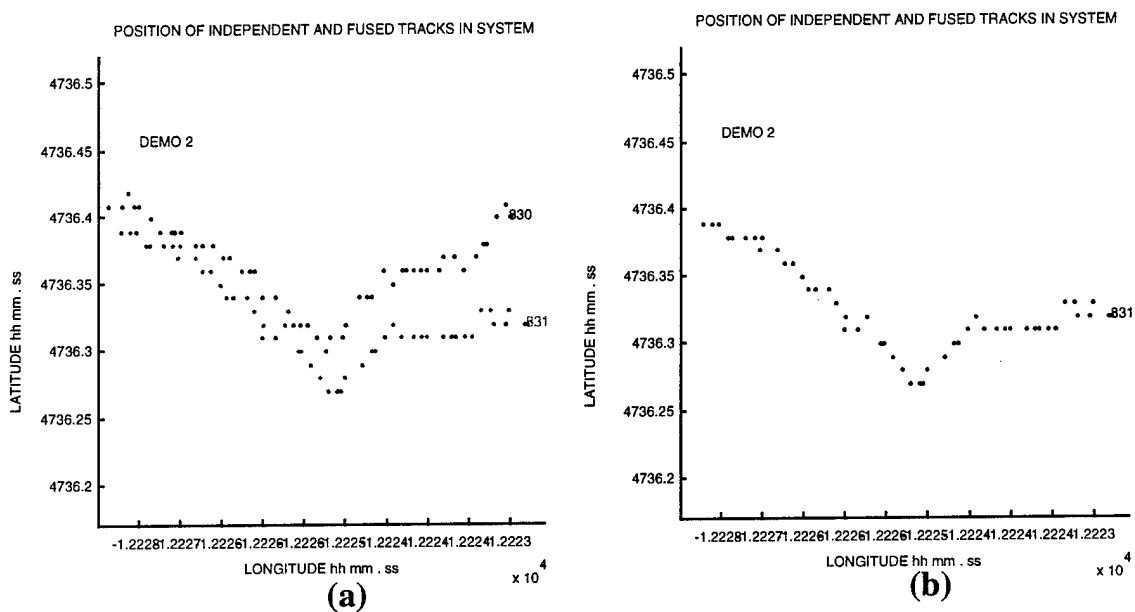

Figure 7. Scenario Plot Example: (a) no fusion applied and (b) fusion applied

the track numbers that were to be extracted to build a demonstration of a particular scenario. Once this procedure has been completed, the demonstration file is ready to run. Demonstration files are easily modified in order to examine time frames of particular interest. There are many variables within the algorithm that can be displayed during execution that will help determine what is actually happening.

The algorithm performed correctly under all test scenarios. The redundant tracks would stay fused as long as each track pair being assessed had a data point within the observation window. There were no problems associated with vessels that were turning and the algorithm always selected

the superior sensor. The algorithm had no trouble dealing with a large amount of tracks and or interruptions in data streams. The following scenarios were considered:

- Scenario 1: Overlapping radar coverage (Tracks 750 and 751) on a single vessel along with an independent vessel (757). Track 751 is initially the superior sensor but drops track causing reporting responsibility to be handed off to track 750. See Figure 8.
- Scenario 2: Overlapping radar coverage (772 and 774) and ADS coverage (Track 773) on a single vessel. Track 773 is the first to acquire the vessel but hands it off to track 772, once 772 acquires the track due to its superior status. Track 774 then acquires track and takes a hand off from 772 due to 774's superior status. See Figure 9.
- Scenario 3: Overlapping radar and ADS coverage on multiple tracks over an extended period. This demonstrates the algorithm's ability to handle many tracks and the potential for a much less cluttered display. See Figure 10.

Several other scenarios were examined, and the algorithm performed well in all cases. In summary, the algorithm fused all tracks that were in the overlap region that met the fusion criteria. It would change reporting responsibility for a track to the next inferior sensor if the superior sensor ceased reporting. The algorithm would change reporting responsibility for a track to a more superior sensor if that sensor started to report on a vessel which was currently assigned to a less capable sensor. It had no trouble with crossing or passing situations. Marginal situations were easy to discriminate as the algorithm would defuse immediately upon failure of the fusion criteria.

The key observations to be made are the affects that the individual membership functions had on the results. If the membership function was not sufficiently broad enough the decision to fuse two tracks was not made. This is particularly true for the course membership function. Vessels that are going extremely slow and or turning tend to have widely varying headings from the radar reports. The addition of fusion parameters, such as size and track quality, would certainly provide a greater degree of confidence in situations where position, course and speed are very close. While the data collected did not contain this type of situation, it is reasonable to assume that this scenario is common in the busy harbors and waterways under the USCG management . These findings are consistent with the simulated overlapping radar results reported in [Ref. 2].

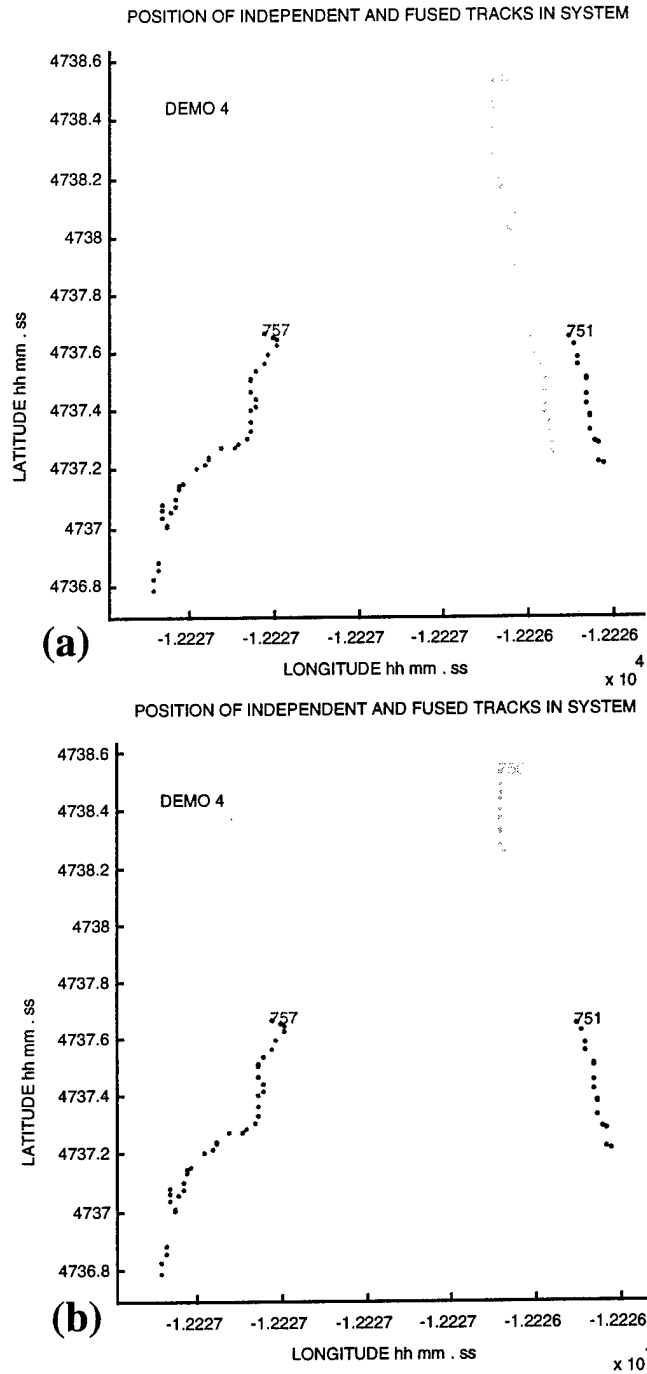

Figure 8 Overlapping Radar Coverage On A Single Vessel With An Independent Vessel:  
 (a) no fusion applied and (b) fusion applied

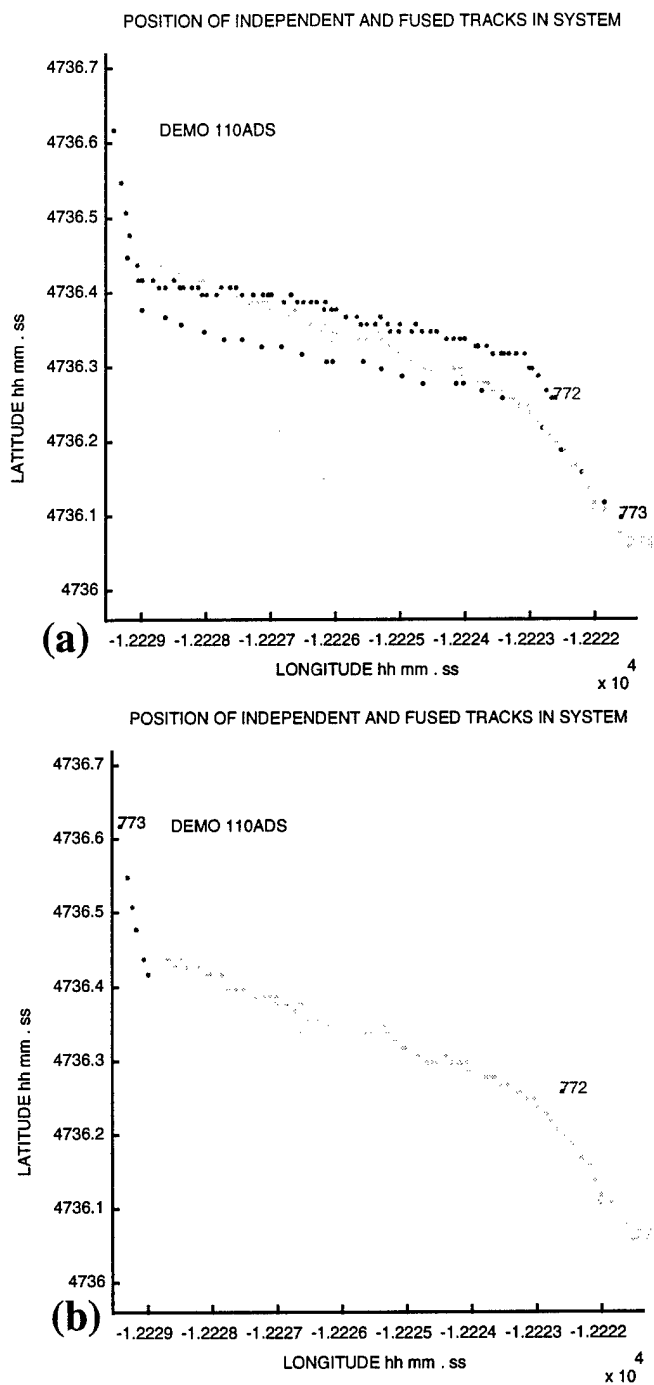

Figure 9. Overlapping Radar and ADS Coverage on a Single Vessel: (a) no fusion applied and (b) fusion applied



## 6. CONCLUSIONS

This report presented an algorithm to fuse redundant observations due to multiple sensor (type and location) coverage in order to provide a significant reduction in duplicate track information provided to the Vessel Traffic Services (VTS) operator displays. The algorithm accepts inputs from multiple sensors (radar, ADS, SR). The algorithm was tested with real data collected from the VTS system at Puget Sound in September 1996. The tests showed that the algorithm correctly fuses redundant sensor observations on the same vessel.

The algorithm's current performance is limited by the number of attributes that could be used to determine association. Only *Latitude*, *Longitude*, *Course* and *Speed* were adopted to determine a level of "sameness" between vessels. The *Course* attribute is not reported with reasonable accuracy by radar when vessels are turning at reasonable speeds.

The performance of the algorithm can be enhanced by adding other attributes from which measures of similarity could be determined. The membership function design needs to be validated by statistical methods once large and varied data sets are available. This will optimize the design of the membership function for a given sensor and sensor suite within the applicable VTS System. Once these membership functions are validated for each type of sensor, the algorithm could be made adaptive. Also, the membership function shape can be adapted not only to the sensor type but also to statistics of the data.

## REFERENCES

1. Midwood, Sean A., "A Computationally Efficient and Cost Effective Multisensor Data Fusion Algorithm for the USCG Vessel Traffic Services System," M.S.E.E. Degree Thesis, Naval Postgraduate School, Monterey, California, September 1997.
2. Glenn, Ian N., "Multilevel Data Association for the Vessel Traffic Services System and Joint Maritime Command Information System," M.S.E.E. Degree Thesis, Naval Postgraduate School, Monterey, California, December 1995.
3. Inter-National Research Institute (INRI), *Tdbm Service Application Programmer's Interface (API) For the Unified Build (UB) Software Development Environment (SDE)*, SPAWARSYSCOM SDE-API-TDBM-2.0.11.5, March 31, 1994.
4. Inter-National Research Institute (INRI), *Functional Description Document for Automated Dependent Surveillance (ADS)*, July 25, 1995.

5. Telephonics, *MTE-2000 Marine Target Extractor Technical Manual*, Part No. 523854, Farmindale, New York, April 1, 1995.
6. "Software Design Document for JMCIS, ADS Proof of Concept (Phase I)," Inter-National Research Institute (INRI), Reston, Virginia, December 1995.
7. "Functional Description Document for the JMCIS ADS VER 1.1," Inter-National Research Institute, Reston, Virginia, December 1995.
8. Hall, D.L., Llinas J., "An Introduction to Multisensor Data Fusion," *Proceedings of the IEEE*, Vol. 85, No. 1, January 1997.
9. Waltz, E. and Llinas, J., *Multi-Sensor Data Fusion*, Artech House Inc., Boston, Massachusetts, 1990.
10. Hall, David L., *Mathematical Techniques in Multisensor Data Fusion*, Artech House Inc., Norwood, Massachusetts, 1992.
11. Kandel, A., *Fuzzy Mathematical Techniques with Application*, Addison - Wesley, Reading, Massachusetts, 1986.



## INITIAL DISTRIBUTION LIST

		No. Copies
1.	Defense Technical Information Center 8725 John J. Kingman Rd., STE 0944 Ft. Belvoir, VA 22060-6218	2
2.	Dudley Knox Library Naval Postgraduate School 411 Dyer Rd. Monterey, CA 93943-5101	2
3.	Research Office, Code 09 Naval Postgraduate School 589 Dyer Rd. Monterey, CA 93943-5138	1
4.	Chairman, Code EC Department of Electrical and Computer Engineering Naval Postgraduate School Monterey, CA 93943-5121	1
5.	Professor Murali Tummala, Code EC/Tu Department of Electrical and Computer Engineering Naval Postgraduate School Monterey, CA 93943-5102	3
6.	Professor Roberto Cristi, Code EC/Cx Department of Electrical and Computer Engineering Naval Postgraduate School Monterey, CA 93943-5102	1
7.	CDR Michael Linzey Command Control Engineering Center 4000 Coast Guard Blvd. Portsmouth, VA 23703-2199	1
8.	LCDR Gordon Weeks Command Control Engineering Center 4000 Coast Guard Blvd. Portsmouth, VA 23703-2199	1

9. LTJG Daniel Pickles 1  
Command Control Engineering Center  
United States Coast Guard  
4000 Coast Guard Blvd.  
Portsmouth, VA 23703-2199
10. LCDR Sean Midwood 1  
PMO Canadian Towed Array Sonar System (CANTASS)  
Director General Maritime Equipment Program Management (DGMEPM)  
Major General George R. Pearkes Building  
National Defence Headquarters  
Ottawa, Ontario, Canada K1A 0K2
11. Major Ian N. Glenn 1  
DASPM 4  
National Defence Headquarters  
Ottawa, Ontario, Canada K1A 0K2