

Anti-Satellite Weapons, Countermeasures, and Arms Control



CONGRESS OF THE UNITED STATES
Office of Technology Assessment
Washington D. C. 20510

19980302 063

U.00158

~~DISTRIBUTION STATE RESTRICTED~~
Approved for public release;
Distribution Unlimited
BMDOTIC

Office of Technology Assessment

Congressional Board of the 99th Congress

TED STEVENS, *Alaska, Chairman*

MORRIS K. UDALL, *Arizona, Vice Chairman*

Senate

ORRIN G. HATCH
Utah

CHARLES McC. MATHIAS, JR.
Maryland

EDWARD M. KENNEDY
Massachusetts

ERNEST F. HOLLINGS
South Carolina

CLAIBORNE PELL
Rhode Island

House

GEORGE E. BROWN, JR.
California

JOHN D. DINGELL
Michigan

CLARENCE E. MILLER
Ohio

COOPER EVANS
Iowa

DON SUNDQUIST
Tennessee

JOHN H. GIBBONS
(Nonvoting)

Advisory Council

WILLIAM J. PERRY, *Chairman*
H&Q Technology Partners

DAVID S. POTTER, *Vice Chairman*
General Motors Corp. (Ret.)

EARL BEISTLINE
Consultant

CHARLES A. BOWSHER
General Accounting Office

CLAIRE T. DEDRICK
California Land Commission

JAMES C. FLETCHER
University of Pittsburgh

S. DAVID FREEMAN
Consultant

GILBERT GUDE
Library of Congress

MICHEL T. HALBOUTY
Michel T. Halbouty Energy Co.

CARL N. HODGES
University of Arizona

RACHEL McCULLOUGH
University of Wisconsin

LEWIS THOMAS
*Memorial Sloan-Kettering
Cancer Center*

Director

JOHN H. GIBBONS

The Technology Assessment Board approves the release of this report. The views expressed in this report are not necessarily those of the Board, OTA Advisory Council, or individual members thereof.

Photo on the cover:

Artist's concept of space-based neutral particle beam weapon. (Photo credit: Los Alamos National Laboratory)

Accession Number: 0158
Cataloged Date: Oct 17, 1985
Number of Copies in Library: 000001
Corporate Author or Publisher: U.s. Congress, Office of Technology
Assessment (OTA), Washington, DC 2
Source of Document: GPO
Descriptors, Keywords: Anti-Satellite Weapon Countermeasure
Arms Control Treaty ASAT Soviet
Satellite Capability Policy History
Pages: 146
Personal Author: Karas, T.H.; Callaham, M.; DalBello,
R.; Epstein, G.; et al.
Publication Date: Sep 01, 1985
Record ID: 19283
Report Number: OTA-ISC-281
Title: Anti-Satellite Weapons,
Countermeasures, and Arms Control
Document Type: HC

Anti-Satellite Weapons, Countermeasures, and Arms Control

OTA Reports are the principal documentation of formal assessment projects. These projects are approved in advance by the Technology Assessment Board. At the conclusion of a project, the Board has the opportunity to review the report, but its release does not necessarily imply endorsement of the results by the Board or its individual members.



CONGRESS OF THE UNITED STATES
Office of Technology Assessment
Washington, D. C. 20510

Recommended Citation:

U.S. Congress, Office of Technology Assessment, *Anti-Satellite Weapons, Countermeasures, and Arms Control*, OTA-ISC-281 (Washington, DC: U.S. Government Printing Office, September 1985).

Library of Congress Catalog Card Number 85-600587

**For sale by the Superintendent of Documents
U.S. Government Printing Office, Washington, DC 20402**

Foreword

At the requests of the House Armed Services Committee and the Senate Foreign Relations Committee, OTA undertook an assessment of the opportunities and risks involved in an accelerated program of research on new ballistic missile defense technologies, including those that might lead to deployment of weapons in space. The resulting report, *Ballistic Missile Defense Technologies*, is being published concurrently with this volume. This report on *Anti-Satellite Weapons, Countermeasures, and Arms Control* discusses additional implications of the same or similar technologies.

Closely related to BMD technology, system survivability, and arms control issues are questions about the development and deployment of anti-satellite weapons. Whether or not the United States decides to deploy BMD systems in space, other military uses of space will continue to grow in importance. How can the United States respond to the potential threat to its military capabilities posed now and in the future both by Soviet military satellites and by Soviet anti-satellite weapons (ASAT)? This report examines U.S. options for countering Soviet military satellite capabilities and explores both unilateral and cooperative measures for limiting the ASAT threat. Possible unilateral steps include active and passive countermeasures as well as deterrence; possible cooperative steps include a variety of arms control agreements. The report examines the pros and cons of several illustrative "arms control regimes" for space weapons, ranging from lesser to greater limitations than now exist. It suggests that some combinations of unilateral and cooperative measures might provide more military security than either type alone.

It should be recognized that the relative roles of anti-satellite weapons, countermeasures, and arms control will be strongly affected by the course followed in the development and deployment of space-based BMD systems.

OTA gratefully acknowledges the contributions of the many individuals, firms, laboratories, and government agencies who assisted its research and writing for this report.



JOHN H. GIBBONS
Director

Advisory Panel on New Ballistic Missile Defense Technologies

Guyford Stever, *Chairman*
President, Universities Research Associates

Solomon Buchsbaum
Executive Vice President
AT&T Bell Labs

Ashton Carter
Kennedy School of Government
Harvard University

Robert Clem
Director of Systems Sciences
Sandia National Laboratories

Sidney D. Drell
Deputy Director
Stanford Linear Accelerator Center

Daniel J. Fink
President
D. J. Fink Associates, Inc.

Richard Garwin
IBM Fellow
Thomas J. Watson Research Center

Noel Gayler, Admiral, USN (Ret.)
American Committee on East-West Accord

Colin Gray
President
National Institute for Public Policy

George Jeffs
President
North American Space Operations,
Rockwell International

General David Jones, USAF (Ret.)
Former Chairman
Joint Chiefs of Staff

Robert S. McNamara
Former President of the World Bank

Michael M. May
Associate Director-at-Large
Lawrence Livermore National Laboratory

H. Alan Pike
Program Manager, Space Stations
Lockheed Missiles & Space Co.

Frederick Seitz
President Emeritus
The Rockefeller University

Robert Selden
Associate Director for Theoretical and
Computational Physics
Los Alamos National Laboratory

Marshall D. Shulman
Director
Harriman Institute for Advanced Study of
the Soviet Union
Columbia University

Ambassador Gerard C. Smith
President
Consultants International Group, Inc.

Sayre Stevens
Vice President
System Planning Corp.

Maj. General John Toomay, USAF (Ret.)
Consultant

Seymour Zeiberg
Vice President
Research and Engineering Operations
Martin Marietta Aerospace

NOTE: OTA appreciates and is grateful for the valuable assistance and thoughtful critiques provided by the advisory panel members. The views expressed in this OTA report, however, are the sole responsibility of the Office of Technology Assessment. Participation on the advisory panel does not imply endorsement of the report.

OTA Project Staff on New Ballistic Missile Defense Technologies

Lionel S. Johns, *Assistant Director, OTA*
Energy, Materials, and International Security Division

Peter Sharfman, *International Security and Commerce Program Manager*

Thomas H. Karas, *Project Director*

Michael Callaham, *Principal Analyst for Anti-Satellite Weapons Report*

Richard DalBello

Gerald Epstein

Anthony Fainberg¹

Robert Rochlin²

Alan Shaw

Administrative Staff

Jannie Coles Dorothy Richroath Jackie Robinson

¹Since February 1985.

²On detail from U.S. Arms Control and Disarmament Agency.

Glossary of Acronyms and Terms

Glossary of Acronyms

ABM	—anti-ballistic missile
ASAT	—anti-satellite
ASATCC	—ASAT Control Center
BMD	—ballistic missile defense
CMC	—Cheyenne Mountain Complex
DSAT	—defensive satellite
DEW	—directed-energy weapon
FEL	—free-electron laser
FOBS	—Fractional-Orbit Bombardment System
GEO	—geosynchronous Earth orbit
GRASER	—gamma-ray amplification by stimulated emission of radiation
GSO	—geostationary Earth orbit
HEO	—high-Earth orbit
INW	—isotropic nuclear weapon
°K	—degrees Kelvin
KEW	—kinetic-energy weapon
LASER	—Light amplification by stimulated emission of radiation; the acronym “laser” is no longer capitalized in current usage

LEO	—low-Earth orbit
LIDAR	—light detection and ranging
LTBT	—Limited Test Ban Treaty
MW	—megawatt
MeV	—million electron-volts
MHV	—miniature homing vehicle
MILSAT	—military satellite
MV	—miniature vehicle
NSSC	—National Space Surveillance Center
PMOC	—Prototype Mission Operations Center
RADAR	—radio detection and ranging; the acronym “radar” is no longer capitalized in current usage
ROCC	—Regional Operations Control Center
SAR	—synthetic aperture radar
SPADATS	—Space Detection and Tracking System
SPADOC	—Space Defense Operations Center
WWMCCS	—World-Wide Military Command and Control System

Glossary of Terms

Ablative Shield: A shield that evaporates when heated, absorbing laser energy and protecting the object which is behind it from heat damage.

Ablative Shock: Generation of a mechanical shock wave at the surface of an object exposed to intense pulsed electromagnetic radiation. A thin layer of the objects surface violently and rapidly boils off; the resulting vapor suddenly exerts pressure against the surface, generating a mechanical shock wave at the surface. This shock wave then propagates deeper into the object and can cause melting, vaporization, and spallation of surface material and structural failure of the object.

ABM Treaty: A Treaty of 1972, signed and ratified by the Soviet Union and the United States, prohibiting development of many types of anti-ballistic missile systems and limiting deployments on each side to a specified number of land-based units, which use only rocket interceptors and ground-based radar.

Acquisition: Detection of a potential target by the sensors of a weapons system.

Active Sensor: One that illuminates a target, producing return secondary radiation, which is

then detected in order to track and/or identify the target. An example is *LIDAR*.

Adaptive Optics: Optical systems which can be modified (e.g., by controlling the shape of a mirror) to compensate for distortions. An example is the use of information from a beam of light, passing through the atmosphere to compensate for the distortion suffered by another beam of light on its passage through the atmosphere. Used to eliminate the “twinkling” of stars in observational astronomy and to reduce the dispersive effect of the atmosphere on laser beam weapons.

Amplified Spontaneous Emission: See *Super-radiance*.

Anti-satellite Weapon (ASAT): A weapon to destroy satellites in space.

Anti-simulation: Deceiving adversary sensors by making a strategic target look like a decoy.

Apogee: The maximum altitude attained by an Earth satellite.

Ballistic Missile Defense (BMD): A defense system that is designed to protect a territory from attacking ballistic missiles.

Birth-to-death Tracking: The tracking of space objects—e.g., satellites, reentry vehicles, or decoys which simulate these—from the time that

- they are deployed from a booster or post-boost vehicle until they are destroyed.
- Bistatic Radar:** A radar system which has transmitters and receivers stationed at two locations; a special case of multistatic radar.
- Boost Phase:** The phase of a missile trajectory from launch to burnout of the final stage. For ICBMs, this phase typically lasts from 3 to 5 minutes, but studies indicate that reductions to the order of 1 minute are possible.
- Brightness:** In this report, the amount of power that can be delivered per unit solid angle by a directed-energy weapon.
- Capital Satellite:** A highly valued or costly satellite, as distinct from an inexpensive decoy satellite. Some decoys might be so expensive as to be considered capital satellites.
- Chaff:** Confetti-like metal foil ribbons which can be ejected from spacecraft (or terrestrial vehicles) to reflect enemy radar signals, thereby creating false targets or screening actual targets from the "view" of radar.
- Coherence:** The matching, in space (transverse) or time (temporal coherence), of the wave structure of different parallel rays of a single frequency of electromagnetic radiation. This results in the mutual reinforcing of the energy of these different components of a larger beam. Lasers and radar systems produce partially coherent radiation.
- Command Guidance:** The steering and control of a missile by transmitting commands to it.
- Counter-countermeasures:** Measures taken to defeat countermeasures.
- Countermeasures:** In this report, measures taken by the offense to overcome aspects of a BMD system.
- Dazzling:** In this report, the temporary blinding of a sensor by overloading it with an intense signal of electromagnetic radiation, e.g., from a laser or a nuclear explosion.
- Decoy:** An object that is designed to make an observer believe that the object is more valuable than is actually the case. Usually, in this report, a decoy refers to a light object designed to look like a satellite.
- Deep Space:** The region of outer space at altitudes greater than 3,000 nautical miles (about 5,600 kilometers) above the Earth's surface.
- Defensive Satellite (DSAT) Weapon:** A space-based ASAT weapon that is intended to defend satellites by destroying attacking ASAT weapons.
- Defensive Technologies Study Team (DTST):** A committee, generally known as the "Fletcher Panel," after its Chair, appointed by President Reagan to investigate the technologies of potential BMD systems.
- Delta-V:** A numerical index of the maneuverability of a satellite or rocket. It is the maximum change in velocity which a spacecraft could achieve in the absence of a gravitational field.
- Diffraction:** The spreading out of electromagnetic radiation as it leaves an aperture, such as a mirror. The degree of spread, which cannot be eliminated by focusing, is proportional to the ratio of the wavelength of radiation to the diameter of the aperture.
- Digital Processing:** The most familiar type of computing, in which problems are solved through the mathematical manipulation of streams of numbers.
- Directed-Energy Weapon:** A weapon that kills its target by delivering energy to it at or near the speed of light. Includes lasers and particle beam weapons.
- Discrimination:** The ability of a surveillance system to distinguish decoys from intended targets, e.g., certain types of satellites.
- Early Warning:** In this report, early detection of an enemy ballistic missile launch, usually by means of surveillance satellites and long-range radar.
- Electromagnetic Radiation:** A form of propagated energy, arising from electric charges in motion, that produces a simultaneous wavelike variation in electric and magnetic fields in space. The highest frequencies (or shortest wavelengths) of such radiation are possessed by gamma rays, which originate from processes within atomic nuclei. As one goes to lower frequencies, the electromagnetic spectrum includes X-rays, ultraviolet light, visible light, infrared light, microwave, and radio waves.
- Electron-volt:** The energy gained by an electron in passing through a potential difference of 1 volt. 6.25 quintillion electron-volts equals 1 joule; 22.5 billion trillion electron-volts equals 1 kilowatt-hour.
- Elliptical Orbit:** A noncircular *Keplerian orbit*.
- Endoatmospheric:** Within the atmosphere; an endoatmospheric interceptor intercepts its target within the atmosphere.
- Ephemeris:** A collection of data about the predicted positions (or apparent positions) of celestial objects, including artificial satellites, at various times in the future. A satellite ephemeris might contain the orbital elements of satellites and predicted changes in these.
- Equatorial Orbit:** An orbit above the Earth's Equator.
- Excimer:** A contraction for "excited dimer"; a type of lasant. A dimer is a molecule consisting of two atoms. Some dimers—e.g., xenon chloride and krypton fluoride—are molecules which cannot exist under ordinary conditions of approxi-

mate thermal equilibrium but must be created in an "excited"—i.e., energized—condition by special "pumping" processes in a laser.

Exoatmospheric: Outside the atmosphere; an exoatmospheric interceptor intercepts its target in space.

Fission: The breaking apart of the nucleus of an atom, usually by means of a neutron. For very heavy elements, such as uranium, a significant amount of energy is produced by this process. When controlled, this process yields energy which may be extracted for civilian uses, such as commercial electric generation. When uncontrolled energy is liberated very rapidly: such fission is the energy source of uranium- and plutonium-based nuclear weapons; it also provides the trigger for fusion weapons.

Fratricide: In this report, the unintended destruction of some of a nation's weapons or other military systems (e.g., satellites) by others.

Free-electron Laser: A type of laser which does not use ordinary matter as a lasant but instead generates radiation by the interaction of an electron beam with a static magnetic or electric field. Loosely speaking, free-electron laser technology resembles and evolved from that used by particle accelerators ("atom smashers"). Lasers which are not free-electron lasers are bound-electron lasers.

Functional Kill: The destruction of a target by disabling vital components in a way not immediately detectable, but nevertheless able to prevent the target from functioning properly. An example is the destruction of electronics in a guidance system by a neutral particle beam.

Fusion: More specifically, nuclear fusion: The fusing of two atomic nuclei, usually of light elements, such as hydrogen. For light elements, energy is liberated by this process. Hydrogen bombs produce most of their energy through the fusion of hydrogen into helium.

Graser: See *Gamma-ray Laser*.

Gamma-ray Laser: A laser which generates a beam of *gamma rays*; also called a *graser*. A gamma-ray laser, if developed, would be a type of X-ray laser; although it would employ nuclear reactions, it need not (but might) employ nuclear fission or fusion reactions or explosions.

Gamma Rays: X-rays emitted by the nuclei of atoms.

Geostationary Orbit: An orbit at an altitude of 35,800 kilometers above the Earth's Equator. A satellite placed in such an orbit revolves around the Earth once per day, maintaining the same position relative to the surface of the Earth. It then appears to be stationary, and can be used as a communications relay or as a surveillance post.

Geosynchronous Orbit: An orbit about 35,800 km

above the Equator. A satellite placed in such an orbit revolves around the Earth once per day. See *Geostationary Orbit*.

Gray: The Système International unit of absorbed dose of ionizing radiation. One gray (abbreviated 1 Gy) is 1 joule of absorbed energy per kilogram of matter.

Hard Kill: Destruction of a target in such a way as to produce unambiguous visible evidence of its neutralization.

Hardness: A property of a target; measured by the power needed per unit area to destroy the target by means of a directed-energy weapon. A hard target is more difficult to kill than a soft target.

High-Earth Orbit: An orbit about the Earth at an altitude greater than 3,000 nautical miles (about 5,600 kilometers).

Homing Device: A device, mounted on a missile, that uses sensors to detect the position or to help predict the future position of a target, and then directs the missile to intercept the target. It usually updates frequently during the flight of the missile.

Impulse: A mechanical jolt delivered to an object. Physically, impulse is a force applied for a period of time, and the Système Internationale unit of impulse is the newton-second (abbreviated N-s). See *Impulse Intensity*.

Impulse Intensity: Mechanical impulse per unit area. The Systeme Internationale unit of impulse intensity is the pascal-second (abbreviated Pa-s) A conventionally used unit of impulse intensity is the "tap," which is one dyne-second per square centimeter; hence 1 tap = 0.1 Pa-s.

Impulse Kill: The destruction of a target, using directed energy, by ablative shock. The intensity of directed energy may be so great that that the surface of the target violently and rapidly boils off delivering a mechanical shock wave to the rest of the target and causing structural failure.

Inclination: The inclination of an orbit is the (dihedral) angle between the plane containing the orbit and the plane containing the Earth's Equator. An equatorial orbit has an inclination of 0° for a satellite traveling eastward or 180° for a satellite traveling westward. An orbit having an inclination between 0° and 90° and in which a satellite is traveling generally eastward is called a prograde orbit. An orbit having an inclination of 90° passes above the north and south poles and is called a polar orbit. An orbit having an inclination of more than 90° is called a retrograde orbit.

Ionization: The removal or addition of one or more electrons to a neutral atom, forming a charged ion.

Isotropic: Independent of direction; referring to

- the radiation of energy, it means "with equal intensity in all directions," i.e., omnidirectional.
- Isotropic Nuclear Weapon (INW):** A nuclear explosive which radiates X-rays and other forms of radiation with approximately equal intensity in all directions. The term "isotropic" is used to distinguish them from nuclear directed-energy weapons.
- Joule:** The *Système Internationale* unit of energy. One kilowatt-hour is 3.6 million joules.
- Keep-out Zone:** A volume around a space asset, off limits to parties not owners of the asset. Keep-out zones could be negotiated or unilaterally declared. The right to defend such a zone by force and the legality of unilaterally declared zones under the Outer Space Treaty remain to be determined.
- Kelvin Temperature:** A scale of temperature on which zero degrees Kelvin (abbreviated 0°K) corresponds to "absolute zero." Temperature in degrees Kelvin equals temperature in degrees Celsius plus 273.16, thus ice melts at 273.16°K , and water boils at 373.16°K .
- Keplerian Orbit:** The orbit which a satellite would follow if the Earth were a uniform sphere with no atmosphere, and if other simplifying assumptions were valid. Such an orbit would be an ellipse having the center of the Earth as one focus. A special case of such an orbit is a circular orbit about the center of the Earth.
- Kill Assessment:** The detection and assimilation of information indicating the destruction of an object under attack. Kill assessment is one of the many functions to be performed by a battle management system.
- Kinetic-Energy Weapon:** A weapon that uses kinetic energy, or energy of motion, to kill an object. Weapons that use kinetic energy are a rock, a bullet, a nonexplosively armed rocket, and an electromagnetic railgun.
- Lasant:** A material that can be stimulated to produce laser light. Many materials can be used as lasants; these can be in solid, liquid, or gaseous form (consisting of molecules—including excimers— or atoms) or in the form of a plasma (consisting of ions and electrons). Lasant materials useful in high-energy lasers include carbon dioxide, carbon monoxide, deuterium fluoride, hydrogen fluoride, iodine, xenon chloride, krypton fluoride, and selenium, to mention but a few.
- Laser:** A device that produces a narrow beam of coherent radiation through a physical process known as stimulated emission. Lasers are able to focus large quantities of energy at great distances, and are among the leading candidates for BMD weapons.
- LIDAR:** A technique analogous to radar, but which uses laser light rather than radio or microwave. The light is bounced off a target and then detected, with the return beam providing information on the distance and velocity of the target.
- Limited Test Ban Treaty:** The multilateral Treaty signed and ratified by the United States and the U.S.S.R. in 1963 which prohibits nuclear tests in all locations except underground.
- Megawatt:** One million watts; a unit of power. A typical commercial electric plant generates about 500 to 1,000 megawatts.
- MeV:** One million electron-volts. A unit of energy usually used in reference to nuclear processes. It is equivalent to the energy that an electron gains in crossing a potential of 1 million volts.
- Micron:** One-millionth of a meter (equivalently, one-thousandth of a millimeter). Roughly twice the wavelength of visible light.
- Midcourse Phase:** The phase of a ballistic missile trajectory in which the RVs travel through space on a ballistic course towards their targets. This phase lasts up to 20 minutes.
- Military Satellite (MILSAT):** A satellite used for military purposes, such as navigation or intelligence gathering.
- Miniature Homing Vehicle (MHV)/Miniature Vehicle (MV):** An air-launched direct-ascent ("pop-up") kinetic-energy ASAT weapon currently being developed and tested by the U.S. Air Force.
- Monostatic Radar:** A radar system in which the receiver and transmitter are colocated.
- Multistatic Radar:** A radar system that has transmitters and receivers stationed at multiple locations; typically, a radar system with a transmitter and several receivers, all of which are geographically separated. A special case is bistatic radar. An advantage of multistatic radar over monostatic radar is that even if transmitters—which might be detected by the enemy when operating—are attacked, receivers in other locations might not be noticed and might thereby escape attack.
- Obscurant:** A material—e.g., smoke or chaff—used to conceal an object from observation by a radio or optical sensor. Smoke may be used to conceal an object from observation by an optical sensor, and chaff may be used to conceal an object from observation by a radio sensor (e.g., radar).
- On-line:** Operating, as distinct from dormant.
- Orbital Elements:** Any set of several parameters (e.g., apogee, perigee, inclination, etc.) used to specify a Keplerian orbit and the position of a satellite in such an orbit at a particular time. Seven independent orbital elements are required to unambiguously specify the position of a satellite in a Keplerian orbit at a particular time.
- Outer Space Treaty of 1967:** A multilateral treaty

signed and ratified by both the United States and the Soviet Union. Article IV of the Outer Space treaty forbids basing nuclear weapons or other weapons of mass destruction in space.

Passive Sensor: One that detects naturally occurring emissions from a target for tracking and/or identification purposes.

Perigee: The minimum altitude attained by an Earth satellite.

Phased-Array Radar (PAR): A radar with elements that are physically stationary, but with a beam that is electronically steerable and can switch rapidly from one target to another. Used for tracking many objects, often at great distances.

Pointing: The aiming of sensors or defense weapons at a target with sufficient accuracy either to track the target or to aim with sufficient accuracy to destroy it.

Polar Orbit: An orbit having an inclination of 90°.

Prograde Orbit: An orbit having an inclination of between 0° and 90°. See *Retrograde Orbit*.

Pumping: In this report, the raising of the molecules or atoms of a lasant to an energy state above the normal lowest state, in order to produce laser light. This results when they fall back to a lower state. Pumping may be done using electrical, chemical, or nuclear energy.

Rad: A unit of absorbed dose of ionizing radiation. One rad is 0.001 *gray*.

Radar: A technique for detecting targets in the atmosphere or in space by transmitting radio waves (e.g., microwaves) and sensing the waves reflected by objects. The reflected waves (called "returns" or "echos") provide information on the distance to the target and the velocity of the target and may also provide information about the shape of the target. (Originally an acronym for "RADio Detection And Ranging.")

Radian: A unit of angular measure. One radian is about 57.3°. One microradian (0.000001 radian) is the angle subtended by an object 1 meter across at a distance of 1,000 kilometers.

Reaction Decoy: A decoy deployed only upon warning or suspicion of imminent attack.

Reentry: The return of objects, originally launched from Earth, into the atmosphere.

Retrograde Orbit: An orbit having an inclination of more than 90°. See *Prograde Orbit*.

Robust: In this report, describing a system, indicating its ability to endure and perform its mission against a reactive adversary. Also used to indicate ability to survive under direct attack.

Salvage-fused: Describing a warhead, that is set to detonate when it is attacked. Usually refers to a nuclear warhead.

Sensors: Electronic instruments that can detect radiation from objects at great distances. The in-

formation can be used for tracking, aiming, discrimination, attacking, kill assessment, or all of the above. Sensors may detect any type of electromagnetic radiation or several types of nuclear particles.

Shoot-back: In this report, the technique of defending a space asset by shooting at an attacker.

Signature: Distinctive type of radiation emitted or reflected by a target, which can be used to identify that target.

Simulation: The art of making a decoy look like a more valuable strategic target. See *Anti-simulation*.

Slew Time: The time needed for a weapon to reaim at a new target after having just fired at a previous one.

Smoke: An obscurant which may be used in the atmosphere or in space to conceal an object from observation by an optical sensor.

Soft Kill: Same as *functional kill*.

Space Detection And Tracking System (SPADATS): A network of space surveillance sensors operated by the U.S. Air Force.

Space Mines: Hypothetical devices that can track and follow a target in orbit, with the capability of exploding on command or by pre-program, in order to destroy the target.

Stimulated Emission: Physical process by which an excited molecule is induced by incident radiation to emit radiation at an identical frequency and in phase with the incident radiation. Lasers operate by stimulated emission.

Superfluorescence: See *Superradiance*.

Superradiance: The process used by a superradiant laser to generate or amplify a laser beam in a single pass through a lasant material, or—in the case of a free-electron laser—through an electric or magnetic field in the presence of an electron beam. Superradiance is actually a form of stimulated emission. Also known as superfluorescence, or amplified spontaneous emission.

Superradiant Laser: A laser in which the beam passes through the lasant only once; mirrors are not required for the operation of such a laser, as they are with more conventional lasers which are sometimes called "cavity lasers" to distinguish them from superradiant lasers. Free-electron lasers may also be superradiant; the laser beam of a superradiant free-electron laser would pass once through an electric or magnetic field (instead of a lasant) in the presence of an electron beam.

Synthetic Aperture Radar (SAR): A radar system which correlates the echoes of signals emitted at different points along a satellite's orbit or an airplane's flight path. The highest resolution achievable by such a system is theoretically equivalent to that of a single large antenna as

wide as the distance between the most widely spaced points along the orbit that are used for transmitting positions. In practice, resolution will be limited and by the radar receiver's signal-processing capability or by the limited coherence of the radio signal emitted by the radar transmitter.

Thermal Kill: The destruction of a target by heating it, using directed energy, to the degree that structural components fail.

Threat: The anticipated inventory of enemy weapons and method of using them.

Tracking: The monitoring of the course of a moving target. Ballistic objects may have their

tracks predicted by the defensive system, using several observations and physical laws.

Warhead: A weapon, usually a nuclear weapon, contained in the payload of a missile.

World-Wide Military Command and Control System (WWMCCS): A communications network linking U.S. forces.

X-ray Laser: A laser which generates a beam or beams of *X-rays*. Also called an "x-raser" or "XRL."

X-rays: Electromagnetic radiation having wavelengths shorter than 10 nanometers (10 billionths of a meter).

Contents

	<i>Page</i>
1. Executive Summary	3
2. Anti-Satellite Weapons, Countermeasures, and Arms Control	25
3. MILSATs, ASATs, and National Security	33
4. ASAT Capabilities and Countermeasures	49
5. ASAT Arms Control: History	91
6. ASAT Arms Control: Options	105
7. Comparative Evaluation of ASAT Policy Options	125
Appendix A: Text of the 1983 Soviet Draft Treaty on the Prohibition of the Use of Force in Outer Space and From Space Against the Earth	145

Chapter 1

Executive Summary

Contents

	<i>Page</i>
Introduction.....	3
Principal Findings.....	3
Comparison of Potential ASAT and Arms Control Regimes	13
1. Existing Constraints.....	13
2. Comprehensive ASAT and Space-Based Weapon Ban	14
3. ASAT Weapon Test Ban and Space-Based Weapon Deployment Ban	15
4. One Each/No New Types	17
5. "Rules of the Road" for Space	17
6. Space Sanctuary	18
7. Space-Based BMD	19
Treaties of Limited Duration.....	20

Tables

<i>Table No.</i>	<i>Page</i>
1-1. Effect of Regimes on ASAT Development and Arms Control	13
1-2. Sensor Technology for Compliance Monitoring	16

Executive Summary

INTRODUCTION

For over two decades the United States and the Soviet Union have used satellites for military purposes. As a result of recent technological advances, military satellites will soon be able to play a more significant role in terrestrial conflicts. These space assets will be able to supply more types of information, more rapidly, to more diverse locations. Some will carry out target acquisition, tracking, and kill assessment functions, thus operating more directly than before as components of weapons systems.

This growing military utility also makes satellites attractive targets for opposing military forces. Both the Soviet Union and the United States have been developing anti-satellite (ASAT) weapons. These weapons could weaken the opponent's military capabilities by depriving his forces of the services of some satellites. The existing Soviet anti-satellite weapons—and future, potentially more effective ASATs—pose a growing defense problem for the United States.

A variety of unilateral measures, passive and active, may improve the survivability of U.S. military satellites. At present, it is un-

clear whether such survivability measures will be adequate to guard against the highly developed ASAT threats of the future. Another possible contributor to satellite survivability is mutually agreed arms control. A judicious combination of certain arms control measures and unilateral satellite survivability measures might provide more security to U.S. military satellites than either type of measure alone.

At the same time, however, arms control measures which constrained the threat to U.S. satellites would also constrain the ability of the United States to weaken Soviet military capabilities by attacking their satellites in time of war. In addition, limits on ASATs would severely limit the kinds of ballistic missile defense weapons that might be deployed in the future. (The subject of ballistic missile defense is dealt with in a companion OTA report, *Ballistic Missile Defense Technologies*.)

This report explains the dilemmas facing U.S. policymakers and assesses the pros and cons of some options for dealing with the challenge of anti-satellite weapons, particularly in the light of projected future weapons technology.

PRINCIPAL FINDINGS

Current Soviet military satellites pose only a limited threat to U.S. military capabilities, but future space systems will pose a greater threat.

The Soviet Union currently uses satellites to perform a wide variety of tasks including missile launch detection, communications, navigation, meteorological surveillance, photographic and radar reconnaissance, and collection of electromagnetic intelligence (e.g., radar emissions). Many of these satellites, al-

though not “weapons” themselves, support and enhance the effectiveness of terrestrial Soviet forces that would engage in direct combat. For example, if navigation satellites improve munition delivery accuracies, then fewer munitions are required to accomplish a given objective. The growing military utility of satellites has rekindled U.S. interest in ASAT weapons.

Some Soviet satellites already supply limited targeting information to other terrestrial

assets. The Administration has expressed its concern about:

... present and projected Soviet space systems which, while not weapons themselves, are designed to support directly the U.S.S.R.'s terrestrial forces in the event of a conflict. These include ocean reconnaissance satellites which use radar and electronic intelligence in efforts to provide targeting data to Soviet weapon platforms which can quickly attack U.S. and allied surface fleets.¹

At present Soviet radar (RORSAT) and electronic intelligence (EORSAT) ocean reconnaissance satellites pose only a limited threat to U.S. and allied surface fleets. RORSATs and EORSATs are typically deployed at altitudes and inclinations which offer limited observation range. Although the observation "swath" of these satellites will eventually cover most of the Earth, if only one or two of these satellites are operational—as has been customary in peacetime—then a ship would be exposed to observation only intermittently and might successfully evade the satellite. The Soviet Union could increase the number of deployed RORSATs and EORSATs, thereby making evasion more difficult. Other countermeasures exist which could further reduce the threat posed by these satellites, but such measures might not be available to merchant resupply vessels operating during a protracted non-nuclear conflict.

In the future, sophisticated communication, navigation, and surveillance satellites are likely to play a greater role in all levels of terrestrial conflict. This will increase the incentive for both the United States and the Soviet Union to develop and deploy ASAT weapons.

Possible responses to the threat posed by Soviet military satellites are numerous and diverse.

A variety of options are available to mitigate the threat to U.S. and allied security posed by Soviet military satellites (MILSATs).

These options include nondestructive as well as destructive measures; those presented below are not mutually exclusive.

- Possible nondestructive responses to Soviet MILSATs:

- Force Augmentation*: U.S. combat or support forces could be increased to counter the increase in effectiveness which Soviet forces could derive from use of military satellites. Force augmentation is often, but not always, more costly than other means of mitigating the threat posed by Soviet military satellites.

- Passive Countermeasures*: By using passive measures to conceal or disguise their identity and nature, U.S. forces could reduce the utility of Soviet reconnaissance satellites. For example, assets now detectable by radar might be redesigned to reflect radar signals only weakly in order to evade detection by radar satellites, or radio silence might be practiced, or covert signaling techniques used to prevent detection by satellites that collect signals intelligence.

- Electronic Countermeasures and Electro-optical Countermeasures*: Electronic countermeasures such as "jamming" (i.e., overloading enemy receivers with strong signals) and "spoofing" (i.e., sending deceptive signals) could be used to interfere with satellite functions. Electro-optical countermeasures such as "dazzling" (temporary "blinding") or spoofing optical sensors are also available. However, these countermeasures—especially spoofing—require detailed knowledge of the satellite systems (e.g., operational frequencies, receiver sensitivity, etc.) against which they are directed.

- Possible Destructive Responses to Soviet MILSATs:

- Inadvertent But Inherent ASAT Capabilities*: The inherent ASAT capabilities of nuclear weapons such as ICBMs and SLBMs could be used to destroy low-altitude Soviet satellites; with some modifications, these weapons might

¹President Ronald Reagan, *Report to the Congress: U.S. Policy on ASAT Arms Control*, Mar. 31, 1984.

also be used to attack satellites at higher altitudes. Some types of non-nuclear interceptors (e.g., that demonstrated in the U.S. Army's 1984 Homing Overlay Experiment (HOE)) which might eventually be developed and deployed for BMD purposes, would have some inherent ASAT capability. Finally, any highly maneuverable spacecraft capable of noncooperative rendezvous—e.g., the U.S. Space Shuttle—has some ASAT potential.

—*Planned ASAT Weapons:* When operational, the current USAF MV ASAT weapon will be able to destroy Soviet military satellites in low-Earth orbit.

—*Advanced ASAT Weapons:* Space- or ground-based directed-energy weapons or advanced kinetic-energy weapons could be developed that would be able to destroy Soviet satellites beyond the range of existing or planned U.S. ASAT weapons.

The United States is now more dependent on satellites to perform important military functions than is the Soviet Union.

In choosing between ASAT weapon development and arms control, one wishes to pursue that course which makes the greater contribution to U.S. national security. This is often characterized as a choice between developing a capability to destroy Soviet satellites while assuming U.S. satellites will also be at risk, or protecting U.S. satellites to some extent through arms control while forfeiting effective ASAT weapons. The better choice could, in principle, be identified by comparing the utility which the United States expects to derive from its military satellites with the disutility which the United States would expect to suffer from Soviet MILSATs during a conflict. Such a comparison—although possible in principle—is made exceedingly difficult by the number of conflict scenarios which must be considered and by the lack of consensus or official declaration about the relative likelihood and undesirability of each scenario.

Although national utility for space system support is difficult to assess precisely and meaningless to compare between nations, it is apparent that the United States is more dependent on MILSATs *to perform important military functions* than is the Soviet Union. The United States has global security commitments and force deployments, while the Soviet Union has few forces committed or deployed outside the borders and littoral waters of members of the Warsaw Treaty Organization and Cuba. The United States has corresponding requirements for global and oceanic command and control communications (C³) capabilities and relies largely on space systems to provide these requirements. The Soviet Union, on the other hand, can rely on landline communications systems and over-the-horizon radio links for many of its C³ needs. Satellite communications links are used by the Soviet Union but are not as essential as those of the United States. In addition, the Soviet Union has greater capability to reconstitute satellites which are lost in action; hence even to the extent the Soviet Union is dependent on space system support, it is less dependent on individual satellites for some functions. The United States also has fewer alternative terrestrial means for collecting intelligence than does the Soviet Union, which can exploit the freedom and openness of U.S. society for this purpose.

Soviet ASAT capabilities threaten U.S. military capabilities to some extent now and potentially to a much greater extent in the future.

The Soviet Union tested a coorbital satellite interceptor system from 1968 until its self-imposed moratorium of August 1983. The Reagan Administration considers this ASAT system to be operational. The interceptors are believed to be capable of attacking satellites at altitudes of up to 5,000 kilometers, depending on their orbital inclination. At present there appear to be only two launchpads for Soviet coorbital interceptors, both located at Tyuratam.

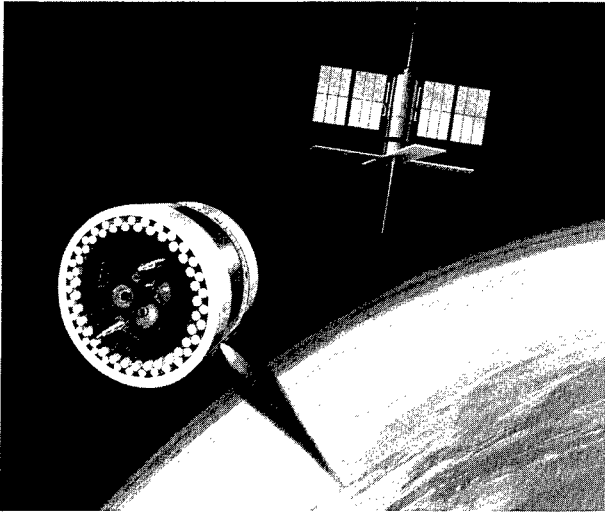

Artist's conception of U.S. MV anti-satellite weapon attacking a satellite. This weapon is still being tested.



Photo credits: U.S. Department of Defense

Artist's conception of a Soviet coorbital anti-satellite weapon attacking a satellite. This weapon is considered by the U.S. Department of Defense to be operational.

The growing military importance of satellites has made them attractive targets. Both the United States and the Soviet Union have been developing anti-satellite (ASAT) weapons.

The existing Soviet ASAT weapon may be effective for negating low-altitude U.S. military satellites, such as are used for navigation (Transit), meteorological surveillance (Defense Meteorological Support Program satellites), and other purposes. Assistant Secretary of Defense Richard Perle has stated:

We believe that this Soviet anti-satellite capability is effective against critical U.S. satellites in relatively low orbit, that in wartime we would have to face the possibility, indeed the likelihood, that critical assets of the United States would be destroyed by Soviet anti-satellite systems. . . . If, in wartime, the Soviet Union were to attack critical satellites on which our knowledge of the unfolding conventional war depended, . . . we would have little choice but . . . to deter continuing attacks on our eyes and ears, without which we could not hope to prosecute successfully a conventional war.²

²Statement of The Honorable Richard Perle, Assistant Secretary of Defense (International Security Policy), in *Hearings before the Subcommittee on Strategic and Theater Nuclear Forces of the Senate Committee on Armed Services: Review of the FY 1985 Defense Authorization Bill*, Mar. 15, 1984 [S.Hrg. 98-724, Pt. 7., p. 3452].

The current Soviet interceptor and the booster that it has been tested with cannot reach critical U.S. early warning and communication satellites in high orbits. If the Soviet ASAT weapon were mated with a larger booster—a procedure which has yet to be tested—it might be able to reach these U.S. satellites.

In addition to the coorbital interceptor, the Soviet Union is testing ground-based lasers which the Reagan Administration believes have ASAT capabilities. The U.S. Department of Defense estimates that the U.S.S.R. could test a space-based laser within the decade.³ Advanced directed-energy weapons such as lasers and particle beam weapons—if developed and deployed—could give the Soviets an “all altitude,” “instantaneous kill” capability. As the United States increases its reliance on space systems to perform vital military functions (e.g., the MILSTAR communication satellite system), an increase in Soviet ASAT capabilities could create a significant threat to U.S. national security.

³U.S. Department of Defense, *Soviet Military Power*, 1985, p. 44.

Aside from its intentional ASAT capabilities, the Soviet Union could currently attack low-altitude satellites with its nuclear ABMs, ICBMs, and SLBMs. With some modification, these nuclear assets might also be used to attack satellites in higher orbits. Current Soviet spacecraft (i.e., Soyuz, Salyut), because of their limited maneuver and rendezvous capabilities, do not have a significant ASAT potential. Future Soviet spacecraft, such as the expected Soviet "Shuttle" and space plane, will have greater inherent ASAT capabilities. The Soviets also have the technological capability to conduct electronic warfare against space systems.

Several technologies on the horizon could lead to a new generation of highly capable ASATs.

The following advanced ASATs could be developed and deployed by either the United States or the Soviet Union:

- *Space Mines:* These would be deployed within lethal range and would continuously trail their target. Using a conven-

tional or nuclear explosive charge, a space mine would destroy its quarry almost instantly on command or (if salvage-fused) when attacked or disturbed.

- *High-Power Radio-Frequency Weapons:* These would be devices capable of producing intense, damaging beams of electromagnetic radiation that could be used to jam communication and radar systems at low power levels or to overload and burn out satellite electronics at higher power levels;
- *High-Energy Laser Weapons:* High-energy lasers may eventually be capable of producing intense, damaging beams of electromagnetic radiation that could jam optical communication and sensor systems at low power levels or cause permanent damage at higher power levels. Ground-based lasers would have infrequent opportunities to attack satellites but, unless attacked themselves, could shoot inexpensively and repeatedly. Space-based reflectors could also be used to relay laser beams from ground-based lasers to their targets. Space-based lasers

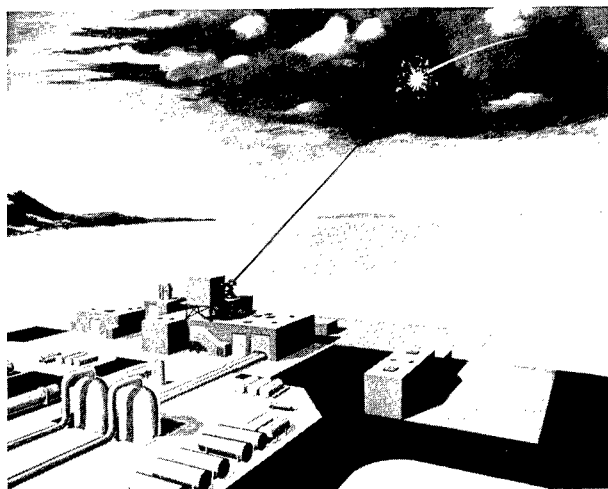

Photo credit: U.S. Air Force

Artist's conception of the High Energy Laser Test Facility, currently under construction at White Sands Missile range, New Mexico.

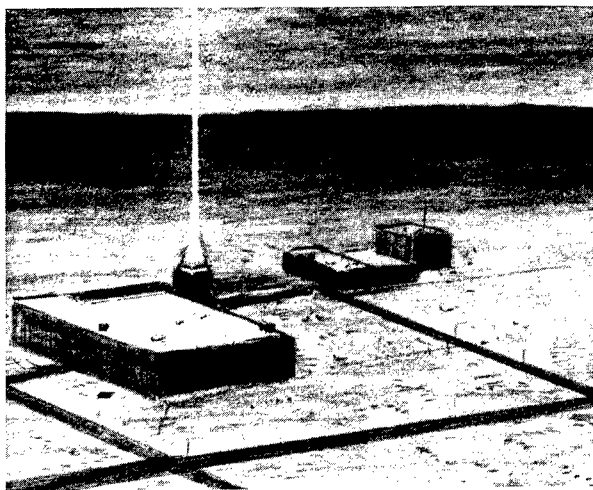

Photo credit: U.S. Department of Defense

Artist's conception of high-energy laser facility at the Sary Shagan test facility in the Soviet Union.

High-energy lasers may eventually be effective ASAT weapons. Ground-based lasers would have infrequent opportunities to attack satellites, but, unless attacked themselves, could shoot inexpensively and repeatedly.

might be able to attack several satellites in quick succession; space-based X-ray lasers might be able to attack several satellites instantly and simultaneously.

- *Neutral Particle Beam Weapons:* Powerful particle accelerators, similar to those now used in scientific research, might eventually be developed which could destroy the hardened electronics of a spacecraft.
- *Kinetic-Energy Weapons:* Space- or ground-based kinetic-energy weapons (similar to the current U.S. MV ASAT) would probably be small, homing vehicles that destroy their target by colliding with it at extremely high velocities.

Possible U.S. responses to the Soviet ASAT threat are numerous and diverse.

The United States could respond to the threat posed by the Soviet ASAT threat in several ways; both unilateral and diplomatic options are available.

- Possible unilateral responses to Soviet ASATs:

—*Reduce Dependence on Military Satellites:* No matter what satellite survivability or arms control measures are taken, there will always be some risk that critical satellites can be destroyed or rendered inoperable. The United States must exercise caution in the extent of its reliance on space assets to perform tasks essential to the national security. Nonetheless, some space systems perform vital military functions which cannot be duplicated—or can be duplicated only imperfectly—by terrestrial systems.

—*Passive Countermeasures:* Passive countermeasures such as hiding, deception (use of decoys), evasion (maneuvering), hardening (making satellites more durable), and proliferation (adding more satellites) all offer significant protection from the current and perhaps future Soviet ASAT weapons. Decoys would probably be effective against a wide va-

riety of ASAT weapons and will be particularly economical for the protection of small satellites capable of being imitated by small, cheap decoys. Combinations of these passive responses—e.g., decoys for “dark” spare satellites—could offer even greater protection than individual measures alone.

- Active Countermeasures:* Active countermeasures may be destructive or non-destructive. Destructive countermeasures could include giving satellites a self-defense capability or providing critical satellites with an escort defense. Nondestructive countermeasures might include electronic countermeasures and electro-optical countermeasures such as jamming. Attacking Soviet ASAT control facilities is also a potential—though dangerous—active countermeasure.
- Deterrence:* The Soviets might be deterred from attacking U.S. satellites if the United States declared its willingness to retaliate for attacks on U.S. space assets. Such retaliation could be against Soviet space assets, in which case the United States would need a capable ASAT weapon, or it could be against Soviet terrestrial assets. The former alternative assumes that the Soviets value the preservation of their satellites at least as highly as they value the destruction of U.S. satellites. The latter alternative, of course, carries a greater risk of uncontrolled escalation if deterrence should fail.
- Keep-Out Zones:* The United States could declare and defend protective zones around critical satellites. Defended keep-out zones could offer significant protection against current ASAT weapons for some satellites. This subject is discussed in detail below.
- Possible diplomatic responses to Soviet ASATs:
 - Arms Control:* The United States, the Soviet Union, and other spacefaring nations could negotiate limitations on the testing, deployment, or hostile use of anti-satellite systems.

—*Rules of the Road:* The United States, the Soviet Union, and other spacefaring nations could negotiate restrictions on potentially provocative activities in space, such as unexplained close approaches to foreign satellites or irradiation of foreign satellites with low-power directed-energy beams. With such agreed restrictions in force, these activities would justify defensive or retaliatory measures.

Of the future ASAT weapons now foreseeable, those which would be most effective if used in a preemptive or aggressive surprise attack would be space-based and therefore subject to attack by similar weapons.

Preemptive attack would be an attractive countermeasure to space-based ASAT weapons. If each side feared that only a preemptive attack could counter the risk of being defeated by enemy preemption, then a crisis situation could be extremely unstable. While salvage-fusing, if it proved practicable, would diminish this risk, it would create a risk of space war breaking out by accident. For example if a meteoroid destroyed a satellite, it might set off a chain reaction of salvage fusing which would destroy all satellites. To the extent that protection was sought through "shoot-back" rather than "shoot-first" tactics, a premium would be placed on having the biggest and best ASATs deployed, which could lead to an intense arms race.

Foreseeable passive or active countermeasures may be inadequate to guarantee the survival of large military satellites attacked by advanced ASAT weapons.

Passive or active countermeasures might have only limited effectiveness against very advanced ASAT or BMD weapons. For example, it might be uneconomical to rely on passive measures to protect large and expensive satellites from a powerful neutral particle beam weapon. Shielding satellites against a

neutral particle beam weapon could cost more than it would to scale up the weapon to penetrate the shielding, and such a weapon could slew its beam quickly enough to make evasion infeasible. With such a weapon it might be as economical to damage spare satellites as they are brought "on line" as it would be to damage initially operational satellites.

Active measures, such as "shoot-back" with a weapon of longer effective range, could provide protection against some ASAT weapons but not against weapons such as space mines or single-pulse lasers which could destroy satellites instantly and without warning. However, it might not be economical to attack satellite systems composed of many small, cheap satellites—and possibly decoys as well—with expensive advanced ASAT weapons. Such satellites could perform a number of important functions (e.g., communication or navigation) without encouraging a proliferation of advanced weapons to attack them. Therefore, although it would be difficult to protect *individual* satellites, satellite *systems* performing some critical functions might retain a fair degree of survivability.

A commitment to satellite survivability is important whether or not ASAT development, or arms control, or both, are pursued.

The United States should place more emphasis on means to ensure the survivability of critical military satellites and, particularly, their associated ground stations and data links, regardless of whether ASAT limitations are agreed upon. The existence of non-ASAT weapons (e.g., ICBMs, ABMs) and space systems (e.g., maneuverable spacecraft) with some inherent ASAT capability makes it impossible to ban the ability to attack satellites. Therefore, even under the most restrictive ASAT arms control regime, programs for satellite survivability and countermeasures must be pursued. In the absence of arms control limitations on ASATs, ensuring satellite sur-

vivability will be a more demanding task since highly capable directed-energy ASAT weapons or space mines could be deployed.

In the absence of restrictions on the development or deployment of ASAT weapons, satellite survivability can be enhanced if the United States is willing to negotiate or declare keep-out zones and is able thereafter to defend such zones against unauthorized penetration by foreign spacecraft.

Although passive or active countermeasures alone may be insufficient to protect satellites, if combined with keep-out zones they could offer a significant degree of protection from certain ASAT weapons. Without keep-out zones space mines could be predeployed next to all critical military space systems. A keep-out zone of sufficient size would reduce the effectiveness of such weapons. However, advanced, directed-energy or kinetic energy ASAT weapons may be able to function effectively even outside very large keep-out zones.

Should ASAT development be pursued, the United States will need to formulate an employment policy.

At present, no clear consensus exists among those Administration military space policy analysts and executives interviewed by OTA on the conditions under which the United States would attack foreign satellites or on the manner in which it would retaliate for an attack on U.S. satellites. If the United States continues with its ASAT development and deployment plans, it will be necessary to formulate an employment policy.

If the United States wishes to enhance the deterrent value of its ASAT weapons, it may choose to publicize certain aspects of its employment policy. It might, for example, promise that the United States would not use its ASAT capabilities in an aggressive or preemptive first strike but might use them in a defensive or retaliatory reaction to an attack against the United States or its allies, even if U.S. satellites were not attacked. That is, the

United States might announce a "no first strike but possible first use" policy for the employment of ASAT weapons as it has for the employment of nuclear weapons.

If defensive satellites (DSATs) are deployed by the United States to defend its satellites, or if certain satellites are given self-defense capabilities, the United States would have to decide under what circumstances it would use these assets and whether it wished to publicly announce this employment policy. The United States might declare in advance that it would fire at satellites suspected of being ASATs if they approached U.S. satellites within possibly lethal range. However, such a declaration would have an uncertain legal status and might generate considerable political opposition from both spacefaring and non-spacefaring nations.

Certain arms control provisions would reduce the probability that advanced ASATs will be developed or deployed. However, arms control could not guarantee the survival of U.S. satellites attacked by residual or covert Soviet ASAT weapons.

Arms control provisions, such as a ban on all testing of all systems "in an ASAT mode," would reduce the likelihood that the Soviet Union could successfully develop and deploy advanced, highly capable ASAT weapons. The categories of weapons eliminated might include space mines capable of "shadowing" valuable military assets in any orbit, directed-energy weapons with kill radii of hundreds to thousands of kilometers, and advanced kinetic-energy weapons. In the absence of an agreement limiting their development, each side would have a strong incentive to seek continually more effective means to attack threatening satellites and to defend valuable assets. In the absence of adequate countermeasures, the "instantaneous kill" capability of some advanced ASATs might be destabilizing in a crisis, because they would give each side an incentive to "shoot first" or else risk the loss of its space assets.



Photo credit: Lockheed

Launch of U.S. Homing Overlay Experiment (HOE) to test nonnuclear anti-ballistic missile technology.

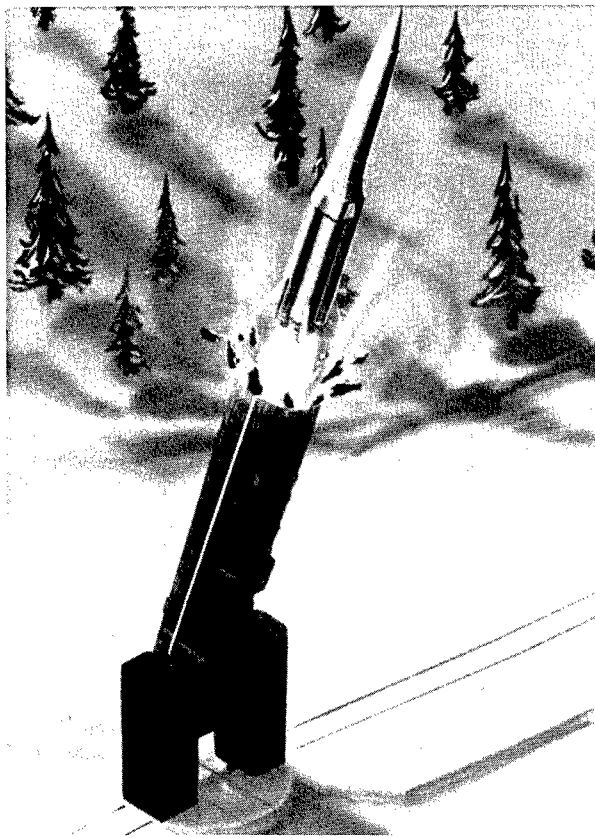

Photo credit: U.S. Department of Defense

Artist's conception of the Soviet GALOSH ABM interceptor currently deployed around Moscow.

ABM interceptors may have some inherent ASAT capabilities. ABMs, as well as ICBMs and SLBMs, present a threat which may not be easily resolved through arms control.

A ban on testing weapons in an ASAT mode would be less effective at reducing the threat posed by weapon systems with inherent ASAT capability and by the existing Soviet ASAT weapon. ICBMs, SLBMs, and ABM interceptors with nuclear payloads are examples of systems with residual ASAT capability. Although these systems lack the kind of precision guidance necessary to actually collide with a satellite, the long-range destructiveness of their nuclear payloads makes them potentially effective ASATs. The Shuttle's recent success at retrieving satellites strongly suggests the ASAT potential of future maneuverable spacecraft, although costly vehicles like the Shuttle would probably not risk approach-

ing satellites which might be booby-trapped. However, the range, effectiveness, and reaction time of even advanced maneuverable spacecraft not designed as weapons would be substantially less than those of intentional ASAT weapons. Although the development of maneuverable spacecraft would not be inhibited by most ASAT testing limitations, some limits could be placed on operating them "in an ASAT mode."

Arms control provisions might substitute for passive and active countermeasures in reducing the threat posed by ASAT weapons, but arms control would be more effective if combined with countermeasures.

U.S. satellites can be protected either by increasing their survivability or by reducing the threat posed by Soviet ASAT weapons. Passive or active countermeasures are designed to do the former while arms control provisions would hopefully do the latter. In considering the advantages and disadvantages of ASAT arms control, ASAT development, and countermeasures, it is important to consider them in packages. A combination of arms control provisions and passive countermeasures, for example, or of passive countermeasures and active countermeasures, could provide greater security than each component of such a package might provide alone.

The benefits of most ASAT limitations conflict with the benefits of ASAT exploitation.

Although ASAT arms control might prevent the Soviet Union from developing advanced, highly capable ASAT weapons, it would also place a similar restriction on the United States. Therefore, although U.S. satellites might be less vulnerable to ASAT attack, the United States would have to give up the ability to strike at Soviet satellites which threaten U.S. and allied forces. Although arms control might prevent an expensive and potentially destabilizing arms race in space, it would also limit the ability of the United States to use its comparative advantage in advanced technology to protect U.S. satellites and place threatening Soviet satellites at risk.

Not all arms control regimes are inconsistent with ASAT development or deployment. "Rules of the road" for space—e.g., negotiated keep-out zones—might be pursued simultaneously with ASAT research, testing, and deployment.

Effective ASAT arms control would likely place significant restrictions on the testing and deployment of future ballistic missile defense systems.

There is considerable overlap between BMD and ASAT technologies. Since even a poor ballistic missile defense system would probably

have excellent ASAT capabilities, any ASAT limitation or test ban would almost certainly impede BMD development. Conversely, technology development ostensibly for advanced ASAT systems might provide some limited BMD capabilities, or, at minimum, information useful in BMD research.

Some available unilateral actions have clear benefits:

- *Deployment of attack sensors* on valuable satellites in order to provide information to support a retaliation decision;
- *Deployment of a space-based, space surveillance system* in order to provide information to support verification of compliance with future arms control agreements; to provide warning information required for effective evasion or dispensing of decoys; to support a decision to retaliate in the event of an attack; and to provide information required for the targeting of ASAT/DSAT weapons⁴;
- *Hardening of military satellites against nuclear effects* to a modest degree in order to preclude "cheap kills" by nuclear-armed ICBMs, SLBMs, or ABMs;
- *Development or maintenance of electronic countermeasures and electro-optical countermeasures*, which would be relatively cheap, useful at all conflict levels, and unlikely to be prohibited by arms control agreements.

The ASAT weapon under development in the United States is sufficient to meet the threat posed by current, low-orbit Soviet military satellites.

Should the United States decide that it is in our national security interest to deploy ASAT weapons, the current MV program and, potentially, interceptors based on the recently tested HOE technology, are sufficient to respond to the threat posed by existing Soviet military satellites in low orbit. The current U.S. ASAT could be made even more effective by the addition of a space-based space surveil-

⁴Because of its usefulness, such a surveillance system would be an attractive target for a Soviet ASAT attack. The ultimate utility of such a system, therefore, hinges on its survivability.

lance system to aid the process of targeting and/or additional basing facilities.

Many of the functions performed by Soviet military satellites may eventually be performed by more capable satellites orbiting at

altitudes out of reach of the U.S. MV. Should this happen, it would provide a strong incentive to extend the MV's capabilities by adding a larger booster or to develop a newer, more capable ASAT system.

COMPARISON OF POTENTIAL ASAT AND ARMS CONTROL REGIMES

There are widely varying views about the wisdom of deploying weapons which are to operate in space or against space objects. This fact, combined with more general concerns about the Soviet military threat and the dangers of the U.S./Soviet arms race, has made it difficult to forge a national consensus on the subject of ASAT weapons. Some people oppose ASAT weapons as a matter of principle because these weapons would operate in space or because such developments would contribute to the arms race. Others believe the benefits of ASAT weapons are outweighed by the risk they pose to current U.S. space systems, which are seen as essential for maintaining U.S./Soviet strategic stability. Still others see the development of ASAT and BMD weapons as a means to exploit U.S. technological advantages to enhance U.S. power, reduce the threat of conflict and global nuclear war, and reduce the damage done by such a war should it ever occur.

In its analysis, OTA has attempted to take into consideration this range of viewpoints and, to the greatest extent possible, show how it leads to a range of policy options. Many of the choices that will be made over the next several years will require a delicate balancing of strategic, economic, and political considerations. There is little doubt that reasonable persons can and will disagree as to the most appropriate nature of this balance.

Seven international legal regimes and corresponding military postures are considered critically below. Each of these regimes is intended to facilitate assessment of the effectiveness and desirability of different combinations

of ASAT and BMD technology development, satellite survivability, and arms control. Each regime is constructed so that it is different from the other regimes and so that it contains elements which might reasonably be expected to co-exist in the same proposal.

1. Existing Constraints

The first regime is defined by treaties and agreements presently in force; these are the Limited Test Ban Treaty, the Outer Space Treaty, and the Anti-Ballistic Missile Treaty. The existing international legal regime prohibits the *use* of ASAT capabilities except in self-defense, the *testing or deployment* of space-based weapons with BMD capability, and the *testing or deployment in space* of nuclear space mines or ASATs that would require a nuclear detonation as a power source.

Table 1-1.—Effect of Regimes on ASAT Development and Arms Control

	Restrict with arms control	Develop ASAT weapons
Existing constraints	No	Yes
Comprehensive ASAT and space-based weapon ban	Yes	No
Test ban and space-based weapon ban	Yes	Yes/No ^a
One each/no new types	Yes	Yes ^b
Rules of the road	Yes	Yes ^c
Space sanctuary	Yes	Yes ^c
Ballistic missile defense	No	Yes

^aIn this regime ASAT weapons could be developed, tested, and deployed on Earth but not in space. The United States could pursue ASAT development within the bounds of the treaty, or it could forego ASAT development entirely.

^bAll ASAT weapons other than "current types" could not be tested or deployed in space.

^cDevelopment and deployment optional but strongly supported by advocates of this regime.

With these few exceptions, all other ASAT weapon development and deployment activities would be allowed. It is, therefore, permissible for the United States and the Soviet Union to develop and deploy coorbital interceptors (like the current Soviet system), direct-ascent interceptors (like the current U.S. system), terrestrial or space-based lasers, space-based neutral particle beam weapons, and weapons based on maneuvering spacecraft.

In the current regime both the United States and the Soviet Union could develop, test, deploy, and use such passive countermeasures as hiding, deception, evasion, hardening, and proliferation. Active, non-destructive defenses, such as electronic or electro-optical countermeasures, would also be allowed. Active, destructive defenses, such as shoot-back or DSATs, would be allowed as long as they did not violate any of the treaties enumerated above.

The primary advantage of the current regime is that it allows the almost unrestrained application of U.S. technology to the twin problems of protecting U.S. satellites and placing threatening Soviet satellites at risk. Under this regime, the United States would be free to use its comparative advantage in advanced technology to keep pace with expected developments in Soviet ASATs and other military satellites. Advanced U.S. ASATs might discourage the development of more capable Soviet space systems designed to place U.S. terrestrial assets at risk. In addition, the United States would be free to respond to Soviet ASAT weapons with increasingly sophisticated defensive weapons and countermeasures, thereby reducing the probability that the Soviets would ever use their intentional or inherent ASAT capabilities.

In the existing regime, research and development on new ballistic missile defense technologies can also proceed without the constraints that might be imposed by certain ASAT arms control regimes. Testing of advanced ASATs could provide valuable information that would contribute to the development of very capable BMD systems. Therefore, some types of generic space-weapon

research could be conducted without first having to modify or withdraw from the ABM Treaty.

Some view advanced ASAT research as dangerous for this very reason. They argue that such research will gradually erode the usefulness of the ABM Treaty, thereby precipitating a defensive and offensive arms competition on Earth and in space. Rather than protecting satellites, a competition in space weapons might severely reduce their military utility. Under conditions of unrestrained competition, security might be purchased, if at all, only at the price of a substantial and sustained commitment to the development of increasingly sophisticated offensive and defensive space weapons. In such an environment, ensuring the survivability of satellites would require more than simple hardening or evasion. Costly measures might have to be taken such as the deployment of precision decoys, pre-deployed spares, or acquiring the ability to quickly reconstitute space assets. Satellites capable of defending themselves or a companion satellite might also have to be developed and deployed.

Should space-based weapons such as space mines or directed-energy weapons be deployed, these might be capable of the almost instantaneous destruction of a large number of critical satellites and ASATs. This could force nations into a situation in which they must "use or lose" their own pre-deployed space weapons. This might supply the incentive to escalate an otherwise manageable crisis.

2. Comprehensive ASAT and Space-Based Weapon Ban

A comprehensive ASAT and space-based weapon ban would require the United States and the Soviet Union to agree to forgo the possession of specialized ASAT weapons, the testing—on Earth or in space—of specialized ASAT capabilities, the testing in an "ASAT mode"⁵ of systems (e.g., ICBMs or ABMs)

⁵Testing in an "ASAT mode" would include tests of ground-, air-, sea- or space-based systems against targets in space or against points in space.

which have inherent ASAT capabilities, and the deployment in space of any weapon. Such a regime would require the U.S.S.R. to destroy all of its coorbital interceptors and the United States to destroy all of its direct-ascent interceptors.⁶

Although this regime contains the most far-reaching arms control provisions, it would have the disadvantage of being the most difficult to verify. Unlike an ASAT test ban and space-based weapons ban regime, a comprehensive ban would prohibit *possession and testing* of ASAT weapons on Earth.⁷ Because the current Soviet coorbital interceptor is a relatively small spacecraft launched on a much larger, general-purpose booster, the Soviet Union could maintain and perhaps even expand its ASAT force without the the United States gaining unambiguous evidence of a violation.

Since the United States might agree to a comprehensive ASAT ban only after considerable domestic political friction over questions of compliance and verification, it is important to consider how such a ban might make a greater contribution to U.S. national security than a ban on ASAT testing and space-based weapon deployment (discussed below). The purpose of both bans would be to prevent the use of ASATs, or, at minimum, to reduce the probability that an ASAT attack would be effective. An ASAT test ban would primarily affect weapons reliability, while an ASAT possession ban, if observed, would affect both availability and reliability. It is conceivable that the risk posed by possible illegal Soviet use of ASAT weapons might be somewhat lower in a regime in which the Soviets could not lawfully possess ASAT weapons. Presumably, the inability to overtly possess ASAT weapons would diminish one's ability to use them effectively. Furthermore,

an absolute ban on possession might make it less likely that the current generation of ASAT weapons could be upgraded and held in readiness in significant numbers.

However, if the United States can only be confident that the Soviets are complying with a treaty to the extent we can verify compliance, then the United States would not have confidence that this regime offered any greater protection to our satellites than would a test ban and space deployment ban.

3. ASAT Weapon Test Ban and Space-Based Weapon Deployment Ban

In this regime, in addition to adhering to treaties and agreements presently in force, the Soviet Union and the United States would agree to forgo all testing in an "ASAT mode" and the deployment of any weapon in space. Such a ban would not only prohibit the testing of both current and future ASAT systems but would also place similar restrictions on BMD systems with ASAT capabilities. This regime would not ban terrestrial research on ASAT or space-based weapons and would not attempt to ban their possession. Therefore, if it were judged to be desirable, ASAT and BMD weapons could be developed (though not tested in space) and held in readiness on Earth.

In a test ban regime, the passive countermeasures and nondestructive active countermeasures that were discussed in the "existing regime" could still be developed and employed. Destructive active countermeasures such as "shoot-back" or DSATs could not be tested or deployed but could be developed and held in readiness.

Although a ban on testing in an "ASAT mode" would not eliminate all threats to satellites, it would reduce the cost and complexity of ensuring a reasonable level of satellite survivability. The United States would still benefit from "hardening" its satellites and deploying spares and decoys, but the more elaborate, expensive, precaution of developing and deploying DSATs would be prohibited and, indeed, less attractive. In the absence of reliable, effective ASATs, satellites would pre-

⁶Such an agreement might resemble the draft treaty proposed to the United Nations by the U.S.S.R. in August of 1983, except that draft also bans the testing or use of manned spacecraft for military purposes. See U.N. Document A/38/194, Aug. 23, 1983.

⁷A comprehensive ban would not ban systems with inherent ASAT capabilities, such as ICBMs, ABMs, and maneuverable spacecraft.

Table 1-2.—Sensor Technology for Compliance Monitoring

Prohibitible action	Observables	Sensors
ASAT attack:		Attack sensors:
KEW ^a impact	acceleration	accelerometers
Pulsed HEL ^b irradiation	acceleration	accelerometers
Continuous HEL irradiation	heating	thermistors
NPB ^c irradiation	ionization	ionization detectors
Keep-out zone penetration	position of thermal radiation source (ASAT)	space-based LWIR ^d thermal imager ^{e f}
Interception test	positions of thermal radiation sources (ASAT and target)	space-based LWIR thermal imager ^{e f}
NPB ASAT operation	thermal radiation from ASAT	space-based LWIR thermal imager ^{e f}
HEL ASAT operation	thermal radiation from ASAT	space-based LWIR thermal imager ^{e f}
Irradiation of target with NPB	gamma radiation from target	gamma-ray spectrometer ^g
Irradiation of target with pulsed HEL	thermal radiation from target	space-based LWIR thermal imager
Irradiation of target with pulsed HEL	reflected radiation from target	space-based multispectral imager
Irradiation of target with continuous HEL	position of thermal radiation source (target)	space-based LWIR thermal imager
Irradiation of target with continuous HEL	reflected radiation from target	space-based multispectral imager
Nuclear explosive aboard satellite	gamma radiation from fissile or fusile nuclei activated by cosmic radiation or by particle beams	gamma-ray spectrometer (and optional particle beam generator)

^aKinetic-energy weapon.

^bHigh-energy laser.

^cNeutral-particle beam.

^dLong-wavelength infrared.

^eThe LWIR telescope on the Infrared Astronomical Satellite (IRAS) exemplifies demonstrated space-based thermal imager technology; this instrument is described in *Astrophysical Journal*, 278 (1, Pt. 2); L1-L85, Mar. 1, 1984 (Special Issue on the Infrared Astronomical Satellite).

^fRadar and passive radio direction-finding methods could also be useful for tracking, if hiding measures are not employed by the penetrating spacecraft. LWIR tracking is emphasized here because it is difficult to counter by such measures.

^gA target irradiated by a high-energy neutral particle beam will emit gamma rays, neutrons, and other observable particles, just as it will, at a slower rate, when bombarded by natural cosmic rays. These gamma rays could be detected by a gamma-ray spectrometer such as those which have been carried by Soviet Venusian and lunar landers and by U.S. NASA Ranger and Apollo spacecraft. (NASA report SP-387, pp. 3-20.)

sumably be of greater utility since the United States might have higher confidence that they would be available when needed.

Relative to the existing regime, the primary advantage of a regime banning testing of ASAT capabilities and deployment of space-based weapons would be that highly valued U.S. satellites in higher orbits—e.g., the future MILSTAR system—could be protected with some confidence from advanced ASAT weapons, especially if protected as well by passive countermeasures. The fact that advanced ASATs could not be overtly tested would reduce the probability that they would be developed and deployed. If they were developed and used without prior testing, a test ban would reduce the probability that they would be successful.

As in the existing regime, the United States could retain a capability to attempt to negate low-altitude Soviet satellites with its MV ASAT (or, possibly, with interceptors based

on the HOE technology) since a “no test” ban would not prohibit ASAT possession. However, confidence in the operational capability of both the U.S. and Soviet ASAT systems would degrade over time without continued operational testing.

There would be two important disadvantages to this regime. First a ban on testing in an “ASAT mode” and deploying space-based weapons would not offer absolute protection for satellites; there would remain some possibility that an untested—or covertly tested—advanced ASAT, if suddenly deployed and used, might actually work well enough to overcome passive countermeasures. Second, without an ASAT weapon the United States would lack a fully tested means to attack threatening satellites. The United States would, therefore, have to place greater reliance on countermeasures to protect its terrestrial assets. It is unclear whether countermeasures alone will be able to keep pace with the threat posed by advances in military satellites.

Depending on one's viewpoint, an additional advantage or disadvantage of this regime is that the testing of some types of advanced BMD weapons would be prohibited. This prohibition might even include some ground-based BMD weapons such as the U.S. HOE (Homing Overlay Experiment) ABM interceptor, which is currently allowed under the ABM Treaty. Although such limitations would only be slightly more restrictive than those of the ABM Treaty, they would be very restrictive when compared to a regime in which the ABM Treaty was no longer in force.

4. One Each/No New Types

Regime four would include arms limitation provisions which would restrict the United States and the Soviet Union to their current ASATs and prohibit the testing in an "ASAT mode" and deployment, in space, of more advanced systems. Existing treaties and agreements would remain in force. In addition to banning the testing or deployment in space of new types of ASATs, the "no new types" agreement would prohibit making current systems more capable so they could attack targets at higher altitudes. BMD systems would also be banned if they had ASAT capabilities.

In a "no new types" regime, the passive countermeasures and nondestructive active countermeasures that were discussed in the "existing regime" could still be developed and employed. Destructive active countermeasures such as "shoot-back" or DSATs could not be tested or deployed but could be developed and held in readiness. Current ASATs—should they already possess the capability when the treaty is signed—could be used to attack other ASATs.

The primary advantage of a "no new types" regime, relative to the existing regime, would be that, by prohibiting the testing of advanced ASAT weapons, highly valued U.S. satellites in higher orbits could be protected with some confidence. In addition, the United States could retain a capability to negate low-altitude Soviet satellites (e.g., RORSAT) in the event of war and to respond in kind to a Soviet ASAT attack.

A primary disadvantage of a "no new types" regime would be that allowed (i.e., tested, nonnuclear) U.S. ASAT weapons would be inadequate to negate threatening Soviet satellites if such satellites were moved to higher orbits—a feasible but technologically difficult and costly Soviet countermeasure. An additional disadvantage to this regime is that attempts to define "new types" of ASATs would be likely to result in the same ambiguity and distrust that resulted from attempts to define "new types" of ICBMs in the SALT II negotiations. Finally, the degree of protection afforded high-altitude satellites by a ban on testing "new types" would be uncertain; there would remain some probability that an untested advanced ASAT, if suddenly deployed and used, might actually work. Systems with inherent ASAT capabilities (ICBMs, ABMs, maneuvering spacecraft) would also still exist.

As in the test ban and space-based weapon ban regime, a "no new types" regime would limit the testing of some types of advanced BMD weapons which are currently allowed under the ABM Treaty.

5. "Rules of the Road" for Space

Whether or not the United States and the Soviet Union agree to restrict ASAT weapons, they might negotiate a set of "rules of the road" for space operations. These rules could serve the general purpose of reducing suspicion and encouraging the orderly use of space, or they could be designed specifically to aid in the defense of space assets. Examples of general rules might include agreed limits on minimum separation distance between satellites or restrictions on very low-altitude overflight by manned or unmanned spacecraft. These general rules might also be used to establish new, stringent requirements for advance notice of launch activities. Specific rules for space defense might include agreed and possibly defended "keep-out zones," grants or restrictions on the rights of inspection, and limitations on high-velocity fly-bys or trailing of foreign satellites. It might also be desirable to establish a means by which to obtain timely information and consult concerning ambiguous or threatening activities.

The "rules of the road" discussed above—if implemented in the absence of restrictions on ASAT weapon development—would not remove the threat of ASAT attack. The primary purpose of such a regime would not be to restrict substantially the activities of the parties, but rather, to make the intentions behind these activities more transparent. Although the degree of protection for U.S. space assets to be gained from a "rules of the road" agreement would be less than from other arms limitation regimes, the costs would also be correspondingly less if other nations failed to comply with such rules. One must assume that in the absence of ASAT arms control, both ASAT development and satellite survivability programs will be given high priority. This being the case, offensive and defensive measures would be available to respond to violations of "rules of the road."

If they were defended, "keep-out zones" would probably offer the closest thing to security in a "rules of the road" regime. Space mines designed to shadow satellites and detonate on command would lose a great deal of their utility if held at bay by a defended keep-out zone. Nonetheless, there are a number of difficulties with trying to implement this regime, not the least of which would be the reaction of other space-faring nations.

ASAT weapons such as nuclear interceptors must be kept at a range of several hundred kilometers from moderately hardened satellites in order to protect such satellites; advanced directed-energy ASAT weapons might have to be kept much farther away. Given the number of satellites currently in orbit, this would present several problems. Satellites in geostationary orbit are already so closely spaced that a keep-out zone sufficiently large to protect satellites from a nuclear weapon would displace other satellites. It is possible that critical strategic warning and communications satellites could function in supersynchronous orbits.⁸ If so, there would be adequate room to accommodate large keep-out zones around satellites in such orbits.

⁸I.e. higher than geosynchronous orbital altitude.

There are too many satellites in low-Earth orbit to accommodate large keep-out zones. However, it might be feasible to establish smaller keep-out zones around such satellites and, in addition, to specify a minimum angular separation between orbital planes to prevent continuous trailing.

6. Space Sanctuary

Regime six would establish altitude limits above which military satellites could operate but where the testing or deployment of weapons would be forbidden. A "space sanctuary" regime would not constrain ASAT weapon development, testing, or deployment in space but would attempt to enhance security by prohibiting these activities in deep space (i.e., above 3,000 nautical miles, or about 5,600 kilometers) where critical strategic satellites are based. At present, the altitude of these strategic satellites makes them invulnerable to attack by the current Soviet and U.S. ASATs.

In a "space sanctuary" regime, the passive countermeasures and nondestructive active countermeasures that were discussed in the "existing regime" could still be developed and employed. Unlike the "test ban" or "no new types" regime, destructive, active countermeasures such as DSATs could be tested and deployed, but not in deep space. Deployment in deep space of "shoot-back" capabilities or DSATs would probably be prohibited since it might be impossible to differentiate these weapons from offensive ASATs.

The primary advantage of this regime would be that it could protect satellites in high orbits from the current generation of ASAT weapons. In addition, a deep-space sanctuary regime would constrain ASAT development less than would a comprehensive test ban regime or a no-new-types regime. However, should the United States and the Soviet Union choose to pursue advanced ASAT weapons, a space sanctuary might offer only limited protection.

The greatest risks in a space sanctuary regime would be posed by advanced directed-energy weapons which could be tested and de-

ployed at low altitudes. Such testing and deployment would probably be adequate to guarantee effectiveness against targets at higher altitudes. Satellites at very high, supersynchronous altitudes might still derive some protection from this regime, but violation of the sanctuary by highly maneuverable kinetic-energy weapons or by satellites covertly carrying powerful nuclear or directed-energy weapons would remain a risk. For this reason, sanctuaries might provide less security than would keep-out zones (discussed above), because *any* foreign satellite entering an agreed keep-out zone could be fired upon, while a satellite entering a sanctuary could be lawfully fired upon only if it could be proven that it was, or carried, a weapon.

7. Space-Based BMD

The seventh regime might result from U.S. or Soviet withdrawal from the ABM Treaty followed by the deployment of space-based BMD systems. Since even a modest BMD system would make a very capable ASAT weapon, in a "space-based BMD" regime there could be no attempt to restrain ASAT development. Moreover, each side would probably want the freedom to develop new ASAT weapons capable of destroying the opponent's space-based BMD systems.

The ASAT weapons allowable under the "space-based BMD" regime would include all of those in the "existing regime," plus weap-

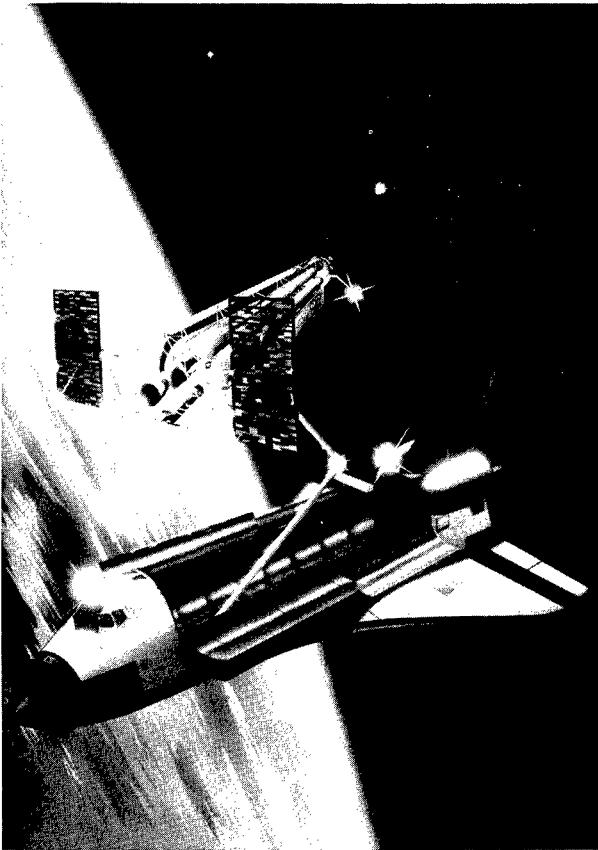

Photo credit: U.S. Department of Energy, Los Alamos National Laboratory

Artist's conception of the Space Shuttle deploying a neutral particle beam weapon.



Photo credit: U.S. Department of Defense

Artist's conception of a manned Soviet space plane attacking a satellite.

Neither of the weapons illustrated here exists today, but in the absence of agreed limitations, both the United States and the Soviet Union will probably develop a wide range of advanced space weapons.

ons capable of countering ballistic missiles in flight. Defensive measures would be less constrained and more essential than in the "existing regime." In particular, advanced space-based weapons such as neutral particle beam weapons could be deployed at low altitudes and then used as ASAT or DSAT weapons. Passive countermeasures and nondestructive active countermeasures like those discussed in the "existing regime" would be developed and employed.

Depending on one's viewpoint, the principal advantage, or disadvantage, of a space-based BMD regime would be that it would allow the United States and the Soviet Union to deploy highly capable weapons in space. On March 23, 1983, President Reagan called for a vigorous research program to determine the feasibility of advanced BMD systems, suggesting that the deployment of such systems, if feasible, could offer an alternative to the current stalemate in strategic nuclear weapons. Given the inherent ASAT capabilities of advanced BMD weapons, satellites would be most vulnerable in a space-based BMD regime. Before the United States deployed space-based BMD systems it would have to determine, first, that the contribution that such systems made to U.S. security was great enough to compensate for the threat which similar opposing systems would pose to U.S. satellites; and, second, that space-based BMD components could be protected at competitive cost against advanced ASAT weapons.

TREATIES OF LIMITED DURATION

Each of the regimes examined above could be negotiated as a treaty of indefinite or limited duration or, alternatively, as one which remained in force as long as periodic reviews were favorable. Each of these alternatives would have its advantages and disadvantages. Treaties of indefinite duration are more effective at discouraging the pursuit of banned activities, yet require a greater degree of foresight regarding the long-term interests of the signatories and can foreclose technological op-

ASAT countermeasures must prove to be effective for space-based BMD platforms if a decision to deploy them is to make sense. Perhaps large improvements in the effectiveness or economy of passive countermeasures such as combinations of hardening, deception, and proliferation would provide the needed protection. Alternatively, the superior fire-power or massive shielding of BMD weapons might give them a degree of protection unattainable by smaller, less capable satellites.

With respect to other military satellites, the expense of equipping them with countermeasures to insure some level of survivability against advanced BMD systems would be considerable. However if, as some argue, space-based missile defenses could make us more secure and encourage the Soviets to make real reductions in offensive missiles, this would reduce the threat of U.S./Soviet conflict. In a world where conflict was less likely, satellite vulnerability would be less important.

Others, of course, disagree strongly with this argument. They claim that space-based missile defenses will decrease our security by encouraging greater competition in both offensive and defensive weapons. In a world of space-based weapons and higher U.S./Soviet tension, satellite vulnerability would be a critical and potentially destabilizing factor.

tions for the indefinite future.⁹ Treaties of limited duration allow parties to take advantage of future technological options, yet can

⁹Treaties of unlimited duration usually contain a clause which states that if a country's "supreme national interests" are threatened, then that country may withdraw from the treaty. In addition to "supreme national interest clauses," treaties may also contain specific unilateral or agreed statements regarding specific understandings about related events. For example, The 1972 ABM Treaty contains a unilateral statement by the United States which links the continued viability of the treaty to "more complete limitations on strategic arms."

encourage aggressive development programs designed to reach fruition at the termination of the designated period. Treaties which call for a periodic reassessment of agreed limitations in theory have great flexibility, yet, in practice, often result in a strong presumption that they should be continued.

The United States might, for example, enter into a treaty limiting ASATs with the explicit and public reservation that we would withdraw from this treaty if and when we were ready to test and deploy a ballistic missile defense system in ways that the ASAT Treaty would forbid. Alternatively, we might take the public position that we intended to restrict our BMD activities so as to remain within the limits of an ASAT Treaty. While the former position would suggest a treaty of limited duration and the latter a treaty of unlimited duration, this need not be the case. It would be perfectly possible to sign a treaty of unlimited duration, with the standard provision allowing for withdrawal, accompanied by a clear statement of some of the conditions under which we intended to withdraw.

From one point of view, the exact language in a treaty regarding its duration would be less important than the intentions of the parties. After all, there have been numerous examples of treaties of unlimited duration that were violated soon after they were signed and examples of treaties of limited duration that con-

tinued in force after they had expired (e.g., the "Interim Offensive Agreement" signed at SALT I). The real issue would be whether the parties believe that adherence to the treaty in question continued to be in their national security interest.

The Reagan Administration has recently indicated that it intends to conduct ASAT tests to gather information useful in advanced BMD research.¹⁰ Given the close connection between these two technologies, an ASAT treaty of even limited duration would require modification of current SDI program plans. Thus, to the extent that the United States wished to maintain the most rapid pace of advanced BMD research within the bounds of the ABM Treaty, such a treaty would not be desirable. Conversely, to the extent that the United States wished to slow the pace of Soviet BMD research and would be willing to defer decisions regarding the testing of space-based or space-directed weapons, an ASAT treaty of limited duration could contribute to that result.

¹⁰The purpose of tests "in an ASAT mode" would be to investigate advanced technologies without violating the ABM Treaty. The Department of Defense recently told Congress that, "To ensure compliance with the ABM Treaty the performance of the demonstration hardware will be limited to the satellite defense mission. Intercepts of certain orbital targets simulating anti-satellite weapons can clearly be compatible with this criteria." [*Report to the Congress on the Strategic Defense Initiative*, Department of Defense, 1985, app. B, p. 8.]

Chapter 2

Introduction

Contents

	<i>Page</i>
Overview	25
Space Weapons: Attitudes and Controversy	26
ASATs and BMD	26
Attitudes Toward the Military Uses of Space	26
Organization of the Report	28

Chapter 2

Introduction

OVERVIEW

This report examines the issues raised by the development of weapons capable of attacking objects stationed in space. It analyzes the military utility of space systems, describes the technical characteristics and military value of anti-satellite (ASAT) weapons, and discusses the effectiveness of a number of satellite defenses and technical countermeasures. Finally, the report examines how various levels of ASAT arms control might contribute to U.S. national security when combined with various survivability measures and various levels of ASAT development and deployment.

Believing that the development of weapons capable of attacking missiles in flight or objects in space would likely have a strong effect on “deterrence, crisis stability, arms control and . . . national security policy,” the House Committee on Armed Services¹ and the Senate Committee on Foreign Relations² asked the Office of Technology Assessment to prepare this report. The committees requested that the report should, among other things, assess:

- the feasibility, effectiveness, and cost of various space-based or space-directed concepts;³
- the relationship between capabilities that can reasonably be expected and the impact of the technology exploitation effort on the overall strategic policy of the United States;⁴

- the implications of anti-satellite weapons and space-based or space-directed missile defense concepts for standing arms control agreements, particularly the Anti-Ballistic Missile, Outer Space, and Limited Test Ban Treaties;⁵ and
- the prospects for future space-related arms control agreements, including an assessment of advantages, disadvantages, and verifiability.⁶

The subject of ballistic missile defense (BMD)—particularly space-based BMD—was of special interest to both the House Armed Services and Senate Foreign Relations Committees. This subject is dealt with in a companion OTA report, *Ballistic Missile Defense Technologies*.

There is a strong relationship between ASAT and BMD technologies and the technical, political, and diplomatic actions taken in one sphere will almost certainly affect the other. For this reason, OTA assessed the two subjects at the same time, with a single staff, and with the advice of a single advisory panel. In each of these reports, OTA has endeavored to make clear the relationship between these two sets of technologies, and where appropriate has provided cross-references to further assist the reader.

In producing this unclassified report, OTA was able to draw on a wide range of classified material. Appendices of classified notes on this report are available to individuals having appropriate security clearances and who require access to that material.

¹Letter from Melvin Price, Chairman, William L. Dickinson, Ranking Minority Member, and Les Aspin of the House Armed Services Committee, to John H. Gibbons, Director, Office of Technology Assessment, Mar. 5, 1984.

²Letter from Charles H. Percy, Chairman, Claiborne Pell, Ranking Member, Larry Pressler, and Paul E. Tsongas of the Senate Foreign Relations Committee to John H. Gibbons, Director, Office of Technology Assessment, Mar. 20, 1984.

³Ibid.

⁴Supra, note 1.

⁵Supra, note 2.

⁶Ibid.

SPACE WEAPONS: ATTITUDES AND CONTROVERSY

Assuming that highly capable and militarily useful ASAT weapons can be built at an acceptable cost, then why not proceed with development and deployment? Why should the U.S. Congress give more attention to ASATs than it gives to other new terrestrial weapon systems (e.g., anti-ship or anti-aircraft weapons)?

ASATs and BMD

Going forward with ASAT weapon development or, alternatively, agreeing to restrict such development through arms control measures, could have important consequences for advanced, space-based BMD technologies. Over the past several years a major debate on strategic defense has been taking place in the United States. Some believe that ballistic missile defenses can be developed that may eventually allow the United States to abandon the current policy of deterrence through assured retaliation. Others believe that even increased research on BMD alternatives might precipitate an offensive arms race with each side hastening to counter possible defenses with more and better offensive arms. This debate was intensified by President Reagan's March 23, 1983, speech which outlined what was later to become the Strategic Defense Initiative.

Since the debate over ballistic missile defense involves a fundamental reassessment of this country's strategic policy, decisionmakers are reluctant to proceed with ASAT weapon development, deployment, or arms control decisions that may tie their hands with respect to future technologies or that may commit them irrevocably to a course with unforeseen consequences. Some people believe that ASAT weapon development programs will be used to accomplish BMD research, thereby avoiding the strictures of the ABM Treaty and the scrutiny of Congress. Others believe that ASAT arms control restrictions would impede future BMD research and development programs. Given these opposing viewpoints, the decision to go forward with or, alternatively, to restrict ASAT development must be made in the

broader context of this country's reassessment of its strategic posture and the military utility of space.

Attitudes Toward the Military Uses of Space

In addition to understanding the complex relationship between ASAT and BMD technologies, one must also recognize that people think about the military use of space in radically different ways. There are a great many views—both pro and con—regarding weapons that would operate in or from space; it is useful to examine several of the more frequently stated positions.⁷

Opposition to Space Weapons

Some people oppose the development of weapons that would operate in or from space because they feel such activities run counter to the legal and political history of space. They point to the many examples of successful international cooperation in space science, commerce, law, and politics and see these activities as reducing international tension and contributing broadly to peace and development. Space weapons are seen as violating the spirit and, in some cases, the letter of the treaties and agreements to which the United States is a party. They point to the language of the 1967 Outer Space Treaty, which states that space activities should be conducted "in the interest of maintaining international peace and security and promoting international cooperation and understanding."⁸ Adherents of this viewpoint emphasize that every American President since Eisenhower has stated

⁷For a discussion of various "space doctrines," see: "Space Doctrines," Lt. Col. D. Lupton, USAF (Ret.), *Strategic Review*, fall 1983, pp. 36-47; see also: Lt. Col. D. Lupton, USAF (Ret.), *On Space Warfare: A Spacepower Doctrine*, U.S. Air Force, Air University Command, Center for Aerospace Doctrine, Research, and Education, Maxwell Air Force Base, Alabama, 1985.

⁸"Treaty on Principles Governing the Activities of States in the Exploration and Use of Outer Space, Including the Moon and Other Celestial Bodies," 18 U.S.T. 2410, T.I.A.S. 6347, Article III.

support for the idea that space should not be an arena of conflict and that space exploration should contribute to peace. The web of commitments that the United States has fashioned over the past 25 years through its agreements and unilateral declarations is seen as imposing a positive burden on the United States to support the broad ideals stated in the Outer Space Treaty.

Others—although acknowledging the importance of the laws and the history of space—base their opposition to space weapons on the belief that the deployment of such weapons in space, if not halted now, will be impossible to reverse. Since neither the United States nor the Soviet Union now has weapons that are based in space, they feel that it is both possible and desirable to prevent the arms race from extending to this new environment. This view is widely held in countries other than the United States and the Soviet Union. Over the last several years, the Soviet Union has made a strong effort to place the blame for the militarization of space on the United States. The American point of view is that the arms race is a burden imposed on the United States by the inordinate military preparations of the Soviet Union. Nonetheless, many nonallied governments, as well as important segments of the populations of even our allies, view the superpower arms race as a dangerous and destabilizing activity.⁹ Those who see the superpower arms race as a dangerous process which the protagonists are doing little to halt are likely to see military development in space as an integral part of that process.

Some opposition to space weapons derives from the fact that such weapons would place at risk critical communication and information-gathering satellites that contribute to the stability of the U.S./Soviet relationship.¹⁰ Space weapons are seen as destabilizing and likely to increase the possibility that a nuclear

war might occur either through accident or intention. At present, nations can use space to peer within the boundaries of other sovereign states to obtain otherwise inaccessible information and early warning of attack. For this reason, many believe that space is of greater value to the United States than to the Soviet Union, since the Soviet Union has other means of gathering information in the open U.S. society. Adherents to this position maintain that, though there are many potential military uses of space, the communication and information-gathering activities are the most important. They argue that these benefits will be jeopardized by U.S./Soviet military space activities such as ASAT weapons development or space-based BMD. Although these latter activities also have military utility, they are not seen as outweighing the risk that such systems would create.

Support for Space Weapons

Those who support the development of weapons that would operate in or from space generally emphasize the importance of being able to exert military power in space. Some supporters view space as merely another sphere of military activity; others feel that military space activities might offer a means by which to fundamentally alter the U.S./Soviet strategic balance. Advocates of the former viewpoint emphasize that the increase in the number of Soviet military space systems with enhanced capabilities creates a threat to which the United States must be prepared to respond. In particular, supporters of this position stress the importance of being able to destroy satellites which assist the Soviets in targeting U.S. terrestrial forces. They believe that in order to deter or, alternatively, to prevail in terrestrial conflicts, the United States must be able to operate in, and respond to threats from, space just as it does on land, at sea, or in the air.¹¹

⁹U.S. Congress, Office of Technology Assessment, *Unispace '82: A Context for Cooperation and Competition—A Technical Memorandum*, OTA-TM-ISC-26 (Washington, DC: U.S. Government Printing Office, March 1983).

¹⁰See: R. Garwin, K. Gottfried, and D. Hafner, "Anti-Satellite Weapons," *Scientific American*, vol. 250, No. 6, June 1984, pp. 45 ff.

¹¹Colin Gray, "Why an ASAT Treaty Is a Bad Idea," *Aerospace America*, April 1984, pp. 70 ff.; and R. F. Futrell, *Ideas, Concepts, and Doctrine: A History of Basic Thinking in the United States Air Force, 1907-1964*, U.S. Air Force, Air University Command, Maxwell Air Force Base, Alabama, 1974, pp. 279-282, summarizing views of Gen. Thomas D. White, USAF.

Some space weapons advocates see space as more than just another theater of military operation; they see it as a solution to the current stalemate in offensive nuclear weapons. They argue that space-based ballistic missile defenses can provide the opportunity for the United States to abandon its current doctrine of assured retaliation. Should both the United States and the Soviet Union possess space-based defensive forces, then more desirable offensive-defensive or purely defensive strategies can be developed. Other space power advocates see space weapons as a means to capture the "high ground."¹² The current U.S. lead in military space technology is seen as granting a military advantage over the Soviet Union—an advantage which, if not seized, will soon be lost.

Because views about the military uses of space vary so widely, it has been difficult to forge a national consensus on the subject of ASAT weapons. Some people oppose ASAT weapons as a matter of principle because these

¹²Lt. Gen. Daniel O. Graham, USA (Ret.), *High Frontier: A Strategy for National Survival* (Washington, DC: High Frontier, 1983).

weapons would operate in space, others oppose ASAT weapons because they believe the benefits of such weapons are outweighed by the risk they pose to current U.S. space systems. Some people support ASAT weapons simply because they feel the United States must be able to respond to Soviet threats from any theater. Other supporters see space as a means to project U.S. power, reduce the threat of conflict and global nuclear war, and reduce the damage done by such a war should it ever occur.

In its analysis, OTA has attempted to take into consideration this range of viewpoints and, to the greatest extent possible, show it leads to a variety of policy options. As this report demonstrates, the opportunities and risks that might result from developing or not developing ASAT weapons or from pursuing or not pursuing ASAT arms control cannot be simply stated. Many of the choices that will be made over the next several years will require a delicate balancing of strategic, economic, and political interests. There is little doubt that reasonable persons can and will disagree as to the most appropriate nature of this balance.

ORGANIZATION OF THE REPORT

The main body of this report begins with the discussion in chapter 3 of the military utility of satellites and ASAT weapons. This chapter provides the conceptual framework necessary to understand how these various space systems contribute to or threaten U.S. national security. Current and projected Soviet and U.S. military satellite capabilities are examined, as are a variety of responses to such capabilities.

Chapter 4 provides a detailed technical look at the existing and projected ASAT capabilities of the United States and the Soviet Union. This chapter discusses both existing technologies and the possibilities for more advanced kinetic-energy, nuclear, and directed-energy ASAT weapons. It also considers the wide range of technical and political responses

available to the United States to counter or compensate for Soviet ASAT capabilities.

Chapter 5 reviews the history of arms control related to ASAT weapons. This chapter describes the constraints imposed by treaties and agreements in force and discusses the international political barriers to ASAT development. The 1978-79 ASAT negotiations between the United States and the Soviet Union are examined, along with subsequent draft treaties proposed by the Soviet Union. Recent legislative and executive branch activities are also summarized.

Chapter 6 describes a number of different ASAT arms control provisions that might be sought by the United States. Restrictions on testing, possession, deployment, and use are

all examined to determine whether they might contribute to U.S. national security. Provisions restricting spacecraft operation and orbits—so-called “rules of the road”—are also examined.

Finally, chapter 7 provides a comparative evaluation of seven hypothetical legal/technical regimes. Each regime combines examples

of technical measures and countermeasures discussed in chapter 4 with examples of arms control as discussed in chapter 6. Each of these hypothetical regimes describes the advantages and disadvantages of different combinations of ASAT weapons development, employment policies, defensive countermeasures, and arms control.

Chapter 3
MILSATs, ASATs, and
National Security

Preceding Page Blank

Contents

	<i>Page</i>
The Role and Value of Military Satellites	33
The Role of Military Satellites	33
Current and Projected MILSAT Capabilities	35
Possible Advanced-Technology MILSAT Capabilities	39
The Value of Military Satellites	40
The Vulnerability and Protection of Military Space Systems	43
The Role and Value of Anti-Satellite Capabilities	44
Military Space Policy	45
Military Space Policy Issues	45
ASAT Policy Issues	45
Ballistic Missile Defense as an ASAT Policy Issue	46

Tables

<i>Table No.</i>	<i>Page</i>
3-1. Asymmetries in U.S. and Soviet Space System Need and Use	34
3-2. Orbits of Some Soviet Military Satellites	37
3-3. Possible Responses to Enemy MILSAT Capabilities	45

Figures

<i>Figure No.</i>	<i>Page</i>
3-1. Ground Track of Soviet Radar Ocean Reconnaissance Satellite	37
3-2. Radar Imagery From Kosmos 1500	38
3-3. Imagery Obtained by Synthetic-Aperture Satellite Radar	40

MILSATs, ASATs, and National Security

THE ROLE AND VALUE OF MILITARY SATELLITES

The Role of Military Satellites

Force Support and Force Enhancement

Satellites are used for a variety of military applications by the United States, the U.S.S.R., and—in smaller numbers—by several other nations. Most military satellites (MILSATs) perform nondestructive functions. For example, Soviet military satellites are used for meteorological surveillance, surveillance of ballistic missile launch areas to provide rapid warning of possible missile attack, relaying of radio communications to distant force elements, optical and radar reconnaissance of foreign force dispositions on land and at sea, interception of foreign radio communications and radar signals, transmission of radionavigation signals, and logistic support for space systems.¹ Even though these functions are nondestructive and the satellites which perform them are not considered weapons, they support force elements which would engage in direct combat and enhance the combat effectiveness of those force elements.

The value, or *utility*, of military satellites is very real, but it is extremely difficult to quantify.² The timeliness of information or the

speed of communications may make the difference between winning a battle and losing one—or it may greatly affect the number of casualties suffered in a battle without deciding victory. In some cases satellites provide capabilities that could not be obtained in any other way—e.g., surveillance of areas which would otherwise be closed to our observation, or providing very early warning of enemy missile launches. In other cases, satellites provide a cheaper and easier way of doing something that could be accomplished by other means—e.g., trans-Atlantic communications. Then there are the navigation satellites, which provide an added degree of precision which may be critical in some applications and only of marginal utility in others.

In a few special cases, satellites contribute to a military mission the objectives or requirements of which can be quantified, as can, therefore, the value of the support provided by satellites. For example, the use of navigation satellites may improve the accuracy with which certain munitions are delivered, thereby reducing wastage of munitions. If so, then the effectiveness of the munitions used would be “multiplied” by satellite support—they would be as effective as a larger number of munitions delivered without the assistance of navigation satellites. The effectiveness of munitions delivery systems would be similarly multiplied. For missions such as this, it is reasonable to think of satellites as “force multipliers,” and the factor by which the forces are multiplied can in principle be used to assess the value of the satellite. This has led some analysts to assess the significance of anti-satellite weapons in terms of the additional forces which the United States would have to procure to maintain military capability if it could not use MILSATs—or could not rely on their availability—in a conflict severe enough to justify Soviet ASAT use.

¹E.g., maintenance and retrieval.

²The term *utility* is used here in the sense defined by John von Neumann and Oskar Morgenstern, *The Theory of Games and Economic Behavior* (Princeton, NJ: Princeton University Press, 1953), pp. 26-27; i.e., as a numerical index of the relative preferability of an outcome [e.g., occurrence of nonnuclear war and survival of all high-altitude satellites] which could result from a decision [e.g., an agreement to ban ASAT weapon testing]. Of any two possible outcomes, the one having a higher utility would be preferred over the other. Practical methods of assessing the utilities of a decisionmaker for possible outcomes have been described and reviewed by M.W. Merkhofer, *Comparative Evaluation of Quantitative Decision-Making Approaches*, National Science Foundation report NSF/PRA-83014, April 1983.

Other notions of utility have been used in the classified literature on satellite utility. Some of these notions are vaguely defined, while others—e.g., force multiplication factors—are precisely defined and, in principle, objectively calculable, although less clearly related to national interests than are Von Neumann-Morgenstern utilities.

However, in assessing the importance of ASATs, it may be more important to consider the *dependence* of military capabilities on space systems. If space system support suddenly becomes unavailable to a force element which has become accustomed to it, the combat effectiveness of that force element may be reduced to lower than it was before it began using space system support. Its effectiveness will be reduced to a fraction of what it was with space system support; the smaller this fraction, the greater the force element's dependence on space support.

There is a trend in both the United States and the U.S.S.R. to use increasingly sophisticated satellites to perform more functions and to do so more capably. It is generally believed that because of its sophisticated and still advancing space technology and because of the global distribution of its interests, commitments, and forces, the United States derives considerable utility from space system support: without satellites, performance of many military missions would become impossible, and performance of others would require large increases in the unit strengths of various U.S. force elements. Other force elements probably derive negligible force multiplication from space support. In general, however, the utility of military satellites to both the United States and the Soviet Union is probably increasing.³ It is also generally believed that because of the expense of other means of providing comparable support to these forces, the United States has not vigorously developed alternative means of support and has consequently become highly dependent on space system support.⁴

Whether the United States derives more military utility from space system support than does the Soviet Union probably cannot be answered in general terms,⁵ although force

³See, e.g., Stephen M. Meyer, "Soviet Military Programs and the 'New High Ground'," *Survival*, Sept./Oct. 1983, pp. 204-215.

⁴Ibid.

⁵According to accepted (e.g., Von Neumann-Morgenstern) axioms of utility theory, utility cannot be assessed in absolute terms but only to within an affine transformation; hence interpersonal or international comparisons of utility are not justifiable in general. See, e.g., Thomas Schelling, *The Strategy of Conflict* (New York: Oxford University Press, 1960), p. 288n, and John Rawls, *A Theory of Justice* (Cambridge, MA: Harvard University Press, 1971), p. 90.

multiplication of particular types of force elements has been estimated in several studies.⁶ Insofar as such estimates are comparable, judgments of *comparative* space support differ. Such differences may be attributable, in part, to exclusion from the scope of some studies, for reasons of security classification, of consideration of some types of satellites which are of great value to the United States but for which the U.S.S.R. has no counterpart or from which the U.S.S.R. might derive much less utility. The utility of some functions of such satellites may be unquantifiable in any case, and this may lead to their neglect in quantitative assessments of utility.

It is easier to argue that the United States is more dependent on space system support for performing important military functions than is the Soviet Union,⁷ because the Soviet Union has less need for some types of space system support and more alternative terrestrial means of providing similar support [see table 3-1]. Moreover, the Soviet Union has

⁶Force multiplication, in those cases where it is meaningful and can be assessed, can be assessed in absolute terms and compared between nations.

⁷Just as international comparison of utility is unjustifiable in principle, international comparison of dependence on space systems is also unjustifiable, if dependence is defined as the loss in utility which it would suffer if its satellites were suddenly incapacitated. Nevertheless, it is apparent that the United States is more dependent on MILSATs to perform important military functions than is the Soviet Union, even though the value of these functions cannot be easily quantified.

Table 3-1.—Asymmetries in U.S. and Soviet Space System Need and Use

Asymmetry	United States	Soviet Union
MILSAT reliability	(+) High	(-) Lower
MILSAT endurance	(+) Long	(-) Shorter
Launch rate	(-) Low	(+) High
Stockpile of spare MILSATs	(-) Low	(+) Higher
C ³ requirements	(-) Global and oceanic	(+) Continental and littoral
Terrestrial C ³ alternatives (relative to requirements)	(-) Few	(+) More
Terrestrial alternatives for information collection (relative to requirements)	(-) Few	(+) More
Operational ASAT capability	(-) No	(+) Yes
ASAT altitude reach	(-) Low	(+) Higher
ASAT responsiveness	(+) High	(-) Low

greater capability to reconstitute satellites which provide such support in case they are lost in action, hence even to the extent the Soviet Union is dependent on space system support, it is less dependent on individual satellites for some functions.

Force Application

Satellites have also been used to provide destructive capabilities. For example, since 1968 the U.S.S.R. has tested a coorbital interceptor—a satellite which could be used to intercept and destroy other satellites. The U.S. Department of Defense estimates that the Soviet Union attained an operational anti-satellite capability with this weapon in 1971.⁸ Although to date there has been little testing and apparently no long-term basing or actual use of weapons in orbit, there is increasing technological potential to do so and, in the United States, increasing overt interest in doing so. In particular, there is strong interest in the United States in using space-based (i.e., satellite) weapons for defensive missions, especially ballistic missile defense and air defense.

Satellites could also provide destructive capabilities in support of other missions. Public Soviet statements have indicated a decreasing interest—indeed, growing opposition—to space-based weapons, although such statements have been interpreted by some in the West as disingenuous and propagandistic, intended for political gain and strategic deception.⁹

Nonmilitary Functions Contributing to National Security

Satellites are also used for nonmilitary applications which contribute to national security,

⁸U.S. Department of Defense, *Soviet Military Power*, 4th ed., Apr. 1985, p. 55. According to analysts of the Congressional Research Service, the U.S.S.R. has also tested a fractional-orbit bombardment system (FOBS), and possibly also a multiple-orbit bombardment system (MOBS), which could employ satellites to bombard terrestrial targets with nuclear warheads [U.S. Congress, Library of Congress, Congressional Research Service, Science Policy Research Division, *Soviet Space Programs, 1971-1975*, Committee Print prepared for the U.S. Senate, Committee on Aeronautical and Space Sciences, Aug. 30, 1976].

⁹U.S. Department of Defense, Defense Intelligence Agency, *Soviet Military Space Doctrine*, report DDB-1400-16-84, Aug. 1, 1984 [UNCLASSIFIED].

such as monitoring compliance with arms control agreements¹⁰ and collecting data for scientific research which could improve future military capabilities.

Current and Projected MILSAT Capabilities

Important asymmetries exist between the space systems of the United States and the Soviet Union and between the ways in which these systems would be employed [see table 3-1]. However, simple comparisons of U.S. and Soviet space systems can be misleading. The Soviet Union has an operational ASAT weapon, the United States does not. Yet, the U.S. ASAT, if developed, will be more capable and versatile than the Soviet ASAT. U.S. satellites are more sophisticated, more reliable, and capable of performing more functions than their Soviet counterparts. Yet, the Soviet's rapid launch capability and policy of maintaining spares would allow them to reconstitute some space assets during a conflict.¹¹

These factors are further modified by the different roles that satellites or ASAT weapons would play in different theaters of war at different levels of conflict. Soviet forces are deployed largely on the Eurasian land mass, and would, in many scenarios, be able to rely on terrestrial communication and information links. In many of the same scenarios, satellite communications would be critical to globally deployed U.S. forces which might lack the same terrestrial communication links. Even in peacetime, the United States relies heavily on surveillance satellites to monitor Soviet compliance with arms control agreements by monitoring Soviet activities which could not be monitored by other lawful means, although similar activities in the United States would be readily observable by Soviet personnel legally in the country.

¹⁰Les Aspin, "The Verification of the SALT II Agreement," *Scientific American*, vol. 240, No. 2, February 1979, pp. 38-45.

¹¹President Ronald Reagan, *Report to the Congress: U.S. Policy on ASAT Arms Control*, Mar. 31, 1984 [UNCLASSIFIED].

Soviet MILSAT Capabilities

The Soviet Union currently uses satellites to perform missile launch detection, communications relaying, radionavigation, meteorological surveillance, photographic and radar reconnaissance, collection of electronic intelligence (ELINT: e.g., radar emissions), and other functions.¹² These functions support a variety of military applications. Of particular concern to the Administration and in Congress¹³ are:

... present and projected Soviet space systems which, while not weapons themselves, are designed to support directly the U.S.S.R.'s terrestrial forces in the event of a conflict. These include ocean reconnaissance satellites which use radar and electronic intelligence in efforts to provide targeting data to Soviet weapon¹⁴ platforms which can quickly attack U.S. and allied surface fleets. In view of the fundamental importance of U.S. and Allied access to the seas in wartime, including for Allied reinforcement by sea, the protection of U.S. and allied navies against such targeting is critical.¹⁵

Soviet ELINT ocean reconnaissance satellites (EORSATs) attempt to detect, localize, and classify ships by detecting the radio signals emitted by their communications and radar systems, while Soviet radar ocean reconnaissance satellites (RORSATs) attempt to detect, localize, and classify ships by detecting radar "echoes" reflected by the ships. RORSATs and EORSATs are typically deployed at altitudes of about 250 and 425 kilometers, respectively, in nearly circular orbits inclined about 65° with respect to the equatorial plane [see figure 3-1 and table 3-2] From these altitudes, these satellites can observe shipping

¹²Ibid., pp. 7 and 12; and U.S. Navy, Office of the Chief of Naval Operations, *Understanding Soviet Naval Developments*, 4th ed., NAVSO P-3560 (Rev. 1/81), Jan. 1981 [UNCLASSIFIED], p. 46.

¹³Hearings before the Subcommittee on Strategic and Theater Nuclear Forces of the Committee on Armed Services United States Senate, *Testimony on Space Defense Matters in Review of the FY1985 Defense Authorization Bill*, S. Hrg 98-724, Pt. 7, pp. 3568-3569.

¹⁴Specifically, anti-ship cruise missiles launched against U.S. surface ships: see U.S. Department of Defense, *Soviet Military Power*, 3d ed., 1984; p. 41.

¹⁵Reagan, op. cit.

over a limited range. The observation "swath" of each satellite will eventually cover the entire earth and ocean surface between latitudes of about 65° north and south. If only one or two RORSATs or EORSATs were operational at one time—as has been customary in peacetime—then a ship in this latitude band would be exposed to observation only intermittently.¹⁶ However, larger numbers of RORSATs or EORSATs could be operational during wartime.

Even if only intermittent, surveillance by RORSATs or EORSATs could assist Soviet forces in targeting Allied shipping to an extent dependent on details of satellite capabilities, such as resolution. For example, Soviet oceanographic radar satellites of the Kosmos-1500 class can obtain radar imagery with a resolution of only 1.5 to 2 kilometers [see figure 3-2], which is inadequate to distinguish an aircraft carrier from a tanker, for example.¹⁷ Various countermeasures could be used by ships to evade observation by these satellites or to reduce the value of their observations to the enemy;¹⁸ some of these are discussed below, in the section entitled "The Role and Value of Anti-Satellite Capabilities."

U.S. MILSAT Capabilities

The United States uses MILSATs to perform most of the functions performed by Soviet satellites, as well as some other functions.

¹⁶Compare the discussion of radar search satellites in *MX Missile Basing*, OTA report OTA-ISC-140, September 1981.

¹⁷In 1983 the Soviet Union launched a civil ocean-surveillance satellite (Kosmos 1500) equipped with a side-looking radar and in the same year placed two satellites (Venera 15 and Venera 16) equipped with similar radar systems into orbits around Venus. The U.S.S.R. has exhibited radar imagery obtained by these satellites. Although the resolution of this radar imagery is poor compared to the 25-meter resolution imagery obtained by NASA's Seasat-A radar satellite in 1978 [see Figure 76B of U.S. Congress, Office of Technology Assessment, *MX Missile Basing*, OTA-ISC-140, Sept. 1981], the 40-meter resolution imagery obtained by NASA's experimental Shuttle Imaging Radar (SIR-A) device in 1982 [see figure 3-3], or the 25-meter resolution imagery obtained by NASA's experimental Shuttle Imaging Radar (SIR-A) device in 1984, Soviet satellite radar technology can be expected to improve, and synthetic aperture radar could be used on future satellites.

¹⁸Reagan, op. cit., p. 13. See also testimony of VADM Gordon R. Nagler, USN, before the HAC Subcommittee on Defense, Mar. 23, 1983.

Figure 3-1.—Ground Track of Soviet Radar Ocean Reconnaissance Satellite

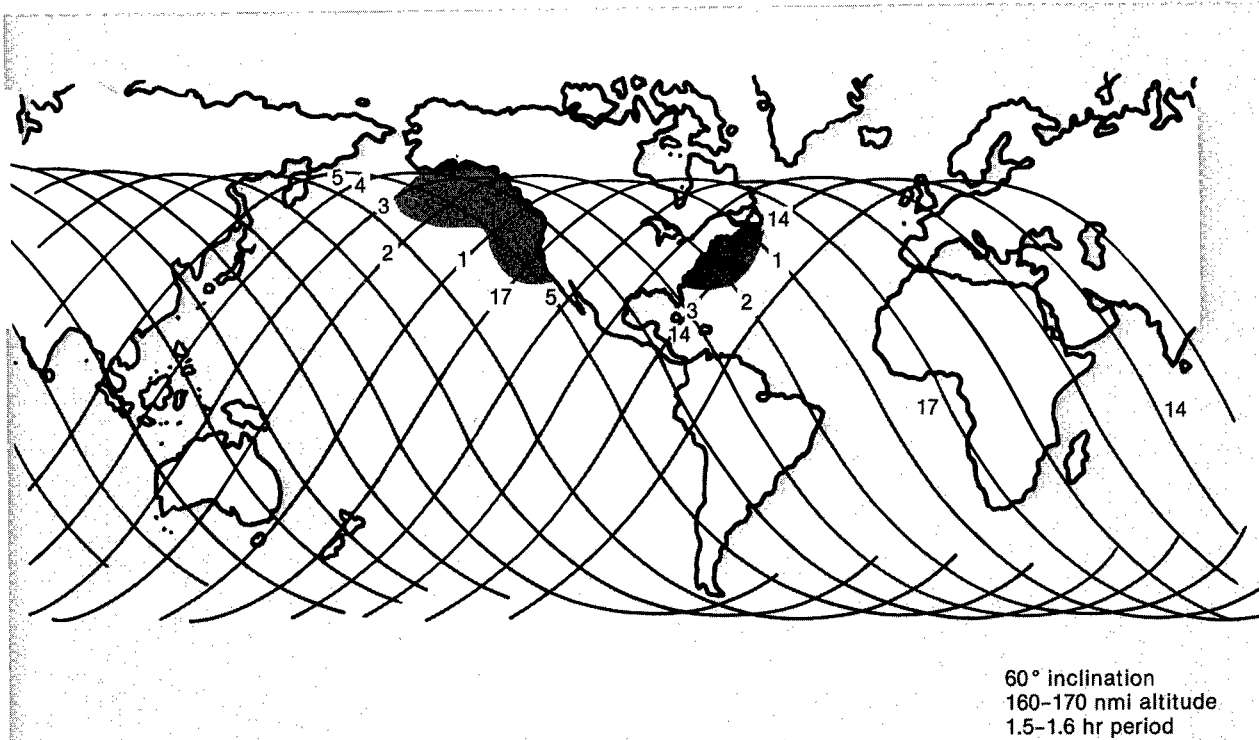

60° inclination
160-170 nmi altitude
1.5-1.6 hr period

SOURCE: Office of Technology Assessment.

Table 3-2.—Orbits of Some Soviet Military Satellites

Perigee-Apogee (km) (km)	Inclination	Apparent mission*
35,785-35,785	0°	communications
19,000-19,200	65°	navigation
965-1,020	47°	communications
940-960	83°	meteorological
855-895	81°	meteorological
790-810	74°	communications
620-660	81°	electronic intelligence (ELINT)
425-445	65°	ELINT ocean reconnaissance (RORSAT)
760-40,000	63°	launch detection
400-40,000	63°	communications
356-415	73°	photo-reconnaissance ^a
250-265	65°	radar ocean reconnaissance (RORSAT)
172-351	67°	photo-reconnaissance ^b

^aManeuverable; initial parameters for Kosmos 1499 given.

^bManeuverable; initial parameters for Kosmos 1454 given.

SOURCES: NASA, *Satellite Situation Report*, vol. 24, No. 5, Dec. 31, 1984; and

*Nicholas L. Johnson, *The Soviet Year in Space: 1983* (Colorado Springs, CO: Teledyne-Brown Engineering, 1984).

U.S. satellites are designed to have longer operational lifetimes in orbit than Soviet satellites, hence fewer satellite launches per year are required to perform similar functions. The complexity of a U.S. satellite may differ from that of a Soviet satellite performing the same function, and the value of this function to the United States may differ from its value to the U.S.S.R.

Attack Warning.—The United States uses infrared sensors aboard satellites in geostationary orbit to detect and promptly report ICBM and SLBM launches; these reports would provide early warning of a missile attack.¹⁹

¹⁹U.S. Department of Defense, *Report of the Secretary of Defense Caspar W. Weinberger to the Congress on the FY 1985 Budget, FY 1986 Authorization Request, and FY 1985-89 Defense Programs*, Feb. 1, 1984 [UNCLASSIFIED], p. 196.

Figure 3-2.—Radar Imagery From Kosmos 1500

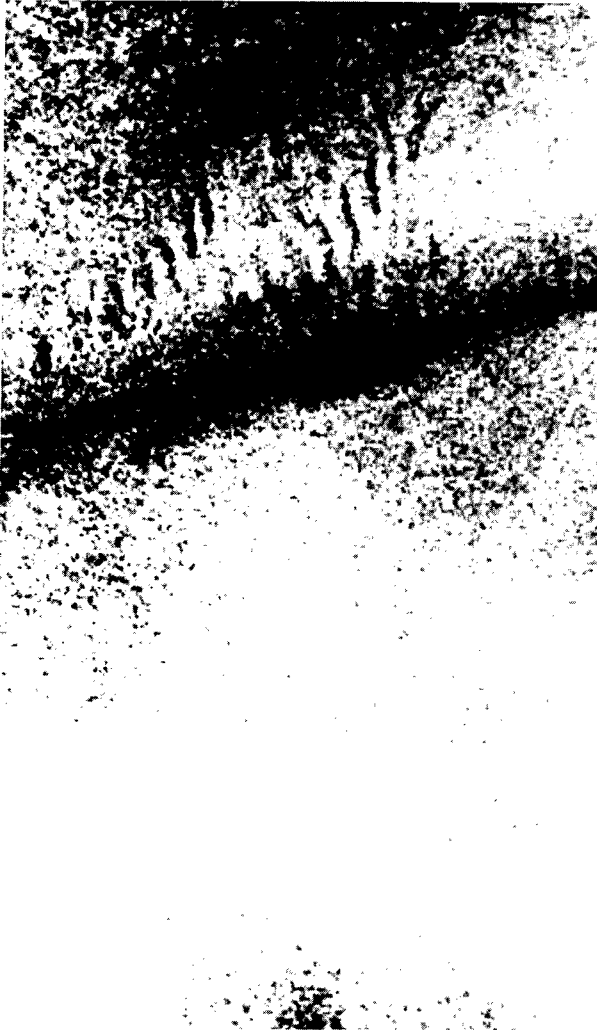

Left, imagery of Atlantic Ocean waves obtained by the Soviet Kosmos 1500 Oceanographic Research Satellite in 1983.



Right, imagery of Honshu Island, Japan obtained by same satellite.

SOURCE: Photographs courtesy of *Aviation Week and Space Technology* (reprinted by permission).

Navigation and Detection of Nuclear Detonations.—U.S. NAVSTAR satellites carry radionavigation beacons for use by Global Positioning System (GPS) receivers on aircraft, ships, and land vehicles. They also carry Integrated Operational Nuclear Detonation Detection System (IONDS) sensors designed to detect nuclear detonations in order to monitor compliance with the Limited Test Ban

Treaty and other treaties in peacetime. In wartime they could be used to confirm a nuclear attack on the United States or its allies in order to support a decision by the National Command Authorities to retaliate, and to assess the success of a retaliatory strike.²⁰

²⁰*Ibid.*

Command and Control Communications.—The United States also uses several different military and commercial communications satellites to provide command and control communications among its globally distributed forces. An advanced satellite communications system called MILSTAR has been designed to replace these and is intended to provide survivable and enduring command and control communications to all four services at all levels of conflict, including general nuclear war.²¹

Meteorological Surveillance.—Defense Meteorological Satellite Program (DMSP) meteorological surveillance satellites provide timely information about weather conditions worldwide. This information is of considerable value in planning military operations, especially flight operations.

Compliance Monitoring.—Photoreconnaissance satellites are used to monitor compliance with arms control treaties and agreements; this function could not be performed as well by any alternative means which is politically acceptable in peacetime, and this function would be unnecessary during war with another party to such treaties, which would be suspended during such a war. However, in wartime the United States would attempt to collect intelligence using satellites²² and other means, such as aircraft overflight, which are acceptable during wartime.

²¹The Honorable Caspar W. Weinberger, Secretary of Defense, *Annual Report to the Congress on the FY 1984 Budget, FY 1985 Authorization Request, and FY 1984-88 Defense Programs*, Feb. 1, 1983 [UNCLASSIFIED].

²²The Honorable Richard Perle, Assistant Secretary of Defense for International Security Policy, has stated:

We believe that this Soviet anti-satellite capability is effective against critical U.S. satellites in relatively low orbit, that in wartime we would have to face the possibility, indeed the likelihood, that critical assets of the United States would be destroyed by Soviet antisatellite systems. . . . If, in wartime, the Soviet Union were to attack critical satellites upon which our knowledge of the unfolding conventional war depended, . . . we would have little choice but . . . to deter continuing attacks on our eyes and ears, without which we could not hope to prosecute successfully a conventional war.

[Hearings before the Subcommittee on Strategic and Theater Nuclear Forces of the Committee on Armed Services United States Senate, *Testimony on Space Defense Matters in Review of the FY1985 Defense Authorization Bill*, S.Hrg. 98-724, Pt. 7., Mar. 15, 1984, p. 3452.]

Possible Advanced-Technology MILSAT Capabilities

Recent and prospective technological advances could be exploited by both the United States and the U.S.S.R.—at different rates—to develop MILSATs which could perform those functions now performed by MILSATs more effectively or economically. Such improvements are possible in the performance of each of the functions mentioned. Of particular interest and concern are possible marked improvements in ocean surveillance, logistic support of space systems, and anti-satellite capability which appear technologically feasible.

For example, radar ocean surveillance satellites using synthetic aperture radar techniques could provide radar imagery of sufficient resolution to permit classification of ships. An example of the potential quality of radar imagery is provided by the radar imagery obtained by the Shuttle Imaging Radar system SIR-A in 1981 [see figure 3-3]. The synthetic aperture radar carried by SIR-A distinguished features as small as 40 meters across. Earlier, in 1978, NASA's Seasat-A demonstrated a resolution of 25 meters; more recently, in 1984, SIR-B demonstrated a comparable resolution. Even finer resolution is possible, and several satellites could be deployed at once to provide frequent opportunities to observe each point on the ocean surface. [Deploying such satellites at higher altitudes for greater coverage would greatly increase the power required and hence also satellite cost.] Both the United States and the U.S.S.R. could deploy radar ocean surveillance satellites using high-resolution synthetic aperture radar technology in the future. Soviet deployment of radar ocean surveillance satellites with improved performance would threaten U.S. and allied shipping to a greater extent than does the existing RORSAT and would provide the United States with a greater incentive to maintain, or, if necessary, develop an ASAT capability to destroy such satellites or otherwise interfere with their performance. Future EORSAT performance could also be improved. With regard to the threat posed by

Figure 3-3.—Imagery Obtained by Synthetic-Aperture Satellite Radar

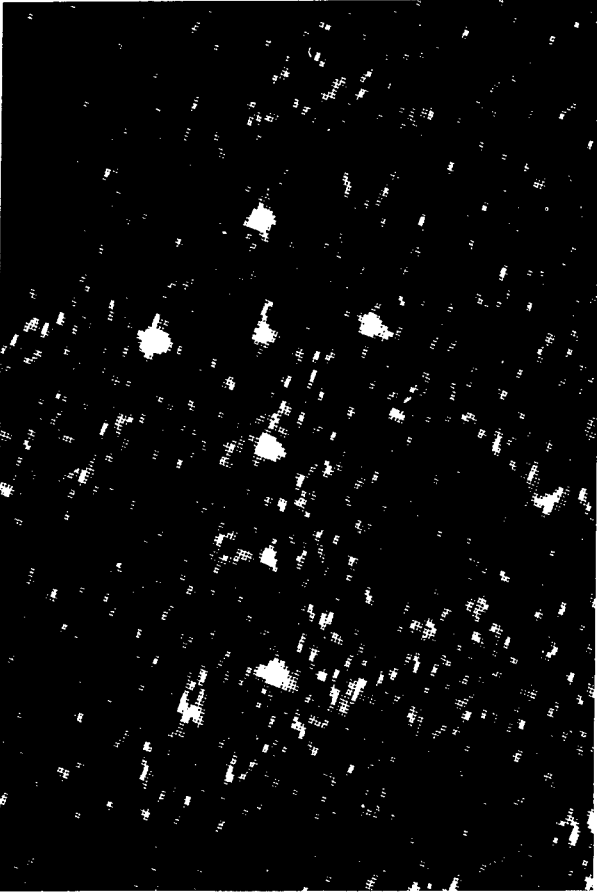

Image of cross-shaped array of radar reflectors near Lake Henshaw, California, obtained by SIR-A in 1981, demonstrating an image resolution of 40 meters. Adjacent reflectors are separated by 300 meters.

SOURCE: U.S. National Aeronautics and Space Administration, Jet Propulsion Laboratory.

such Soviet MILSATs to U.S. and allied shipping, the Administration has expressed concern that “as Soviet military space technology improves, the capabilities of Soviet satellites that can be used for targeting are likely to be enhanced and represent a greater threat to U.S. and allied security.”²³

The logistic support and anti-satellite capabilities of space systems could also be enhanced greatly in the future. Potential future

²³Reagan, *op. cit.*, p. 7. See also testimony of VADM Gordon R. Nagler, USN, before the HAC Subcommittee on Defense, Mar. 23, 1983.

ASAT capabilities are discussed in chapter 4 of this report.

Recent and prospective technological advances could also be exploited to enable future MILSATs to perform functions not now performed by MILSATs. For example, the United States could develop and deploy space surveillance satellites to detect and track foreign satellites. This capability could be used to detect impending attacks on U.S. or allied satellites in time to permit countermeasures to be used; it could confirm success of such attacks in order to support a decision to retaliate (not necessarily in kind); it could monitor compliance with possible future ASAT arms control or “Rules of the Road in Space” agreements; and it could provide targeting information for U.S. anti-satellite weapons. Space surveillance satellites could provide continuous space object detection and tracking capabilities which cannot be duplicated by ground-based radars (which have limited search range) and photographic or electro-optical sensors (which cannot be used in daytime or through overcast).

The United States and the U.S.S.R. could also develop satellite (i.e., space-based) weapons capable of attacking a variety of targets other than satellites—e.g., ballistic missiles, aircraft, ships, and fixed or mobile targets on land.²⁴ Assessment of the military capabilities which such weapons might eventually be able to provide requires an understanding of the feasibility of making them survivable at affordable costs and is beyond the scope of this report, which is limited to survivability issues. The feasibility and value of space-based ballistic missile defense system components—including weapons—is discussed in a companion OTA report, *Ballistic Missile Defense Technologies*.

The Value of Military Satellites

Estimation of the force multiplication effects which satellites might provide *under specific circumstances* might be done objectively, by means of combat modeling and simulation,

²⁴LTC David Lupton, USAF (Ret.), *op. cit.*, pp. 36-47.

and analysis of historical combat data. The costs of the additional "equivalent forces" which the satellite services would, in effect, replace might be used as an upper bound on the value of the satellites under those circumstances. However, the expected utility, or worth, of such force multiplication cannot be determined by such an analysis without assuming probabilities that the forces supported will be involved in various conflict situations, estimating the force multiplication expected in each such situation and the additional costs averted by such force multiplication, and averaging these averted costs over all such situations. This would be a demanding, and probably infeasible, analytical task, because assessment of such values and probabilities is necessarily subjective and hence subject to dispute. However, some judgments of value are conventionally accepted and can be rationalized to a considerable extent.

For example, the missile attack warning function performed by U.S. MILSATs has been described as being of "vital" importance to national security.²⁵ The navigation and nuclear detonation detection functions performed by the GPS and IONDS mission packages aboard NAVSTAR satellites have been described as "critical," as has the communications function to be performed by MILSTAR and currently performed by a variety of satellites [see box entitled "The Dependence of U.S. Command and Control Performance on Satellite Communications Systems"].²⁶ Surveillance satellites have been described as "critical assets,"²⁷ and the surveillance func-

tion which they perform has been called "vital."²⁸

Other satellites are seldom judged to be of importance comparable to those aforementioned, although some are of considerable value. For example, after DMSP cloud imagery and DMSP-derived forecasts were made available to aircraft carriers operating in Southeast Asia, sorties of carrier-based aircraft scheduled for strike and reconnaissance missions which required clear weather in the target area were canceled when meteorological data from DMSP satellites showed overcast in the target area, and the aircraft which had been assigned to the canceled sorties were reassigned to other missions. This use of DMSP data decreased the number of aircraft required to perform a number of assigned missions in a given time, or, equivalently, increased the number of aircraft available to fly such missions.

As another example, the navigational accuracy of missiles and aircraft which rely on very accurate, unaided inertial navigation systems depends on geopotential anomaly data collected by geophysical research satellites.

Some of the functions performed by satellites, and the satellites which perform them, are most valuable in peacetime, while others would be more important in crisis, conventional war, or nuclear war. However, determination of the nature of the dependence of satellite value on the level of conflict is complicated by the fact that in many cases the

²⁵The Honorable Hans Mark, then Secretary of the Air Force, in testimony in 1980 hearings before the U.S. Congress, House of Representatives, Committee on Science and Technology, stated that "two missions [strategic missile warning and surveillance] above all others stand out as being of vital importance to national security." [*United States Civilian Space Policy*, House Document 153, 96th Cong., 2d sess., July 23-24, 1980; pp. 93-94].

²⁶Responses of LTG Robert D. Russ, USAF, Deputy Chief of Staff for Research, Development, and Acquisition, to questions submitted by The Honorable Norman Dicks in FY1985 Defense Appropriations hearings before the U.S. House of Representatives, Committee on Appropriations, Subcommittee on Defense, vol. V, 1984.

²⁷The Honorable Richard Perle, Assistant Secretary of Defense (International Security Policy), has stated that "We believe that this Soviet anti-satellite capability is effective against

critical U.S. satellites in relatively low orbit, that in wartime we would have to face the possibility, indeed the likelihood, that critical assets of the United States would be destroyed by Soviet anti-satellite systems."—Statement of The Honorable Richard Perle, Assistant Secretary of Defense (International Security Policy), *Hearings before the Subcommittee on Strategic and Theater Nuclear Forces of the Committee on Armed Services United States Senate, Testimony on Space Defense Matters in Review of the FY1985 Defense Authorization Bill*, Mar. 15, 1984, S. Hrg. 98-724, Pt. 7, p. 3452.

²⁸The Honorable Hans Mark, then Secretary of the Air Force, in testimony in 1980 hearings before the U.S. Congress, House of Representatives, Committee on Science and Technology, stated that "two missions [strategic missile warning and surveillance] above all others stand out as being of vital importance to national security." [*United States Civilian Space Policy*, House Document 153, 96th Cong., 2d sess., July 23-24, 1980; pp. 93-94].

The Dependence of U.S. Command and Control Performance on Satellite Communications Systems

It has been estimated that about 70 percent of all U.S. military electronic communications are routed through communications satellites.¹ In peacetime, much of such traffic consists of administrative messages which would be inessential to the conduct of war. Therefore, the dependence of U.S. military capabilities on satellite communication systems, although undoubtedly substantial, is not necessarily represented accurately by the fraction of message traffic routed through satellites during peacetime. The dependence of U.S. military capabilities in several theaters on satellite communication systems is reflected qualitatively in the following views of military commanders and staff analysts.

Command and Control in the Southwest Asian Theater.—The dependence of command and control within the Southwest Asian theater and between that theater and the continental United States on satellite communications systems has been noted by Lieutenant General Robert C. Kingston, USA (Commander, Rapid Deployment Joint Task Force):

. . . the challenge is to establish and maintain strategic communications upward, necessary linkages laterally, and tactical communications downward. Strategic connectivity in the [Southwest Asian] region is limited today. The backbone of the Defense Communications System cannot be accessed directly except by satellite or HF over long distances. The FLTSAT and DSCS II systems support this need for all the services. DSCS III, the follow-on satellite, will soon be launched with a new booster. The HF programs, however, especially in the anti-jamming arena, need better interoperability. At present, limited HF links must transmit beyond optimum distances to reach DCA entry points and are subject to frequent atmospheric interruptions.²

Command and Control in the Pacific Theater.—Similar concern has been expressed by Lieutenant General Joseph T. Palastra, Jr., USA (Deputy Commander-in-Chief, Pacific) about the dependence of command and control within the Pacific theater and between that theater and the continental United States on satellite communications systems:

A critical problem is the Pacific area's heavy reliance on satellite and undersea cable systems. The Soviet Union's demonstrated ability to destroy satellites has made it urgent to implement countermeasures and modernize backup high frequency systems so we can deploy at least minimum essential communications.³

Command and Control in the European Theater.—Command and control between the European theater and the continental United States depends on similar means which are similarly vulnerable. Command and control within the European theater depends less on satellite communications, for reasons noted by Major General Robert A. Rosenberg, USAF (then Assistant Chief of Staff, Studies and Analyses, Headquarters, U.S. Air Force):

It is interesting to watch a simulated war-game exercise in the central region of Europe when the communications circuits are removed to simulate loss or destruction. The German Post Office telephone system is used to contact another command center when the military primary lines are down.⁴

¹Colonel Robert B. Giffen, *US Space System Survivability: Strategic Alternatives for the 1990s*, National Security Affairs Monograph Series 82-4 (Washington, D.C.: National Defense University Press, Fort Leslie J. McNair, 1982), pp. 22-23.

²Lieutenant General Robert C. Kingston, USA, "C³I and the Rapid Deployment Force," *Worldwide Deployment of Tactical Forces and the C³I Connection*, Proceedings of the National Security Issues 1982 Symposium, Oct. 4-5, 1982, MITRE Corp. document M82-64, 1982.

³Lieutenant General Joseph T. Palastra, Jr., USA, "Pacific Command Perspectives," *Worldwide Deployment of Tactical Forces and the C³I Connection*, Proceedings of the National Security Issues 1982 Symposium, Oct. 4-5, 1982, MITRE Corp. document M82-64, 1982.

⁴Major General Robert A. Rosenberg, USAF, "Satisfying C³I Requirements for Deployed Air Forces," *Worldwide Deployment of Tactical Forces and the C³I Connection*, Proceedings of the National Security Issues 1982 Symposium, Oct. 4-5, 1982, MITRE Corp. document M82-64, 1982.

value of a function performed by a satellite may be realized at a later time and at a different—probably higher—level of conflict than that at which the function was performed.

For example, missile attack warning data would be most valuable during a nonnuclear war, when anticipation of such an attack would be most intense and when it would be most important to be reassured that the nation is *not* under attack when such is indeed the case. Once the United States has confirmed that it has been so attacked, or is under attack, or decides to retaliate for a non-nuclear attack by Warsaw Pact forces against NATO allies, further warning information would be of value only if additional salvos were expected, as in “nuclear war-fighting” scenarios.

As another example, the value of geopotential anomaly data collected by satellite might be greatest during nuclear war, although to be of value then such data must have been collected and analyzed—a lengthy process—during peacetime.

The problem of assessing the values of MILSAT capabilities and ASAT capabilities will be discussed in greater detail in appendix D to this report.

The Vulnerability and Protection of Military Space Systems

The value of MILSAT functions performed during wartime can be realized only if MILSATs survive long enough to perform them. Most current MILSATs are vulnerable to deliberate nuclear or nonnuclear attack, and some are vulnerable to nondestructive electronic countermeasures and electro-optical countermeasures. However, only a few U.S. MILSATs are potentially vulnerable to current Soviet nonnuclear ASAT weapons, and these could be made less so.

Satellites operate as components of space systems, which include terrestrial components such as satellite control facilities and user terminals (the “ground segment”) as well as the

satellites themselves (the “space segment”). Attacks against either segment can disrupt the functioning of a military space system and negate or reverse the force enhancement it provides. Hence both MILSATs and their associated ground equipment must be effectively protected against attack if the value of their wartime functions is to be realized. Technical measures—i.e., active and passive countermeasures—can provide some protection by reducing the MILSAT vulnerability, and legal measures—i.e., arms control treaties treaty or customary law banning threatening activities in space—can provide some protection by constraining ASAT capabilities which could be used against MILSATs. Arms control measures could be used in combination with passive countermeasures to constrain potential ASAT threats and reduce vulnerability to those which would remain. However, some arms control measures would be incompatible with some active countermeasures, such as shoot-back with ASAT weapons.

U.S. responses to current and future ASAT threats need not be limited to legally constraining such threats and protecting and defending satellites from those which remain. Other possible responses include deterrence of ASAT attack by maintaining a capability to retaliate (not necessarily in kind), using non-destructive electronic countermeasures and electro-optical countermeasures against the space and ground segments of ASAT systems, attacking the ground segment of ASAT systems, augmenting other forces to compensate for MILSAT vulnerability, and reducing dependence on MILSATs.

[Technical countermeasures are discussed in greater detail in chapter 4 of this report, and arms control and other legal measures are discussed in chapters 5 and 6. In practice, passive countermeasures, and probably active countermeasures as well, would be used in conjunction with arms control; such combinations of arms control and technical countermeasures are discussed in greater detail in chapter 7 of this report.]

THE ROLE AND VALUE OF ANTI-SATELLITE CAPABILITIES

To the extent that enemy MILSATs could increase the effectiveness of enemy forces, capabilities to damage such MILSATs or to degrade their functioning would be valuable in wartime. In addition to such destructive and nondestructive ASAT capabilities, other options are available to reduce the utility of MILSATs to an enemy or to compensate for their disutility to the United States.

Electronic and electro-optical countermeasures can be used to provide nondestructive ASAT capabilities which could be used at any level of conflict. They would be particularly valuable during crises short of declared war, in which satellite destruction would be escalatory and hence in many cases undesirable. "Active" electronic countermeasures such as "jamming" (i.e., overloading enemy receivers with strong signals) and "spoofing" (i.e., sending deceptive signals) could be used to interfere with satellite functioning, as could such active electro-optical countermeasures as temporary blinding (or "dazzling": the optical counterpart to jamming) and spoofing. Such nondestructive ASAT measures are discussed in chapter 4 of this report.

At higher levels of conflict, ASAT weapons could be used to destroy enemy satellites. The inherent ASAT capabilities of nuclear weapons such as ICBMs and SLBMs could be used for negation of low-altitude MILSATs at nuclear levels of conflict, while at nonnuclear levels of conflict the inherent ASAT capabilities of the experimental nonnuclear ABM technologies demonstrated in Homing Overlay Experiment (HOE) tests could be used for low-altitude MILSAT negation, as could the U.S. Air Force's Miniature Vehicle ASAT weapon, when operational. Negation of satellites at higher altitudes or more rapid negation of low-altitude satellites would require more capable ASAT weapons such as are discussed in chapter 4 of this report.

Alternatively, or supplementally, various passive measures could be used in peacetime, crisis, and war *not* to interfere with the functioning of enemy MILSATs but rather to decrease the value of their functions to the

enemy and, more importantly, to mitigate or compensate for the harm such satellites could cause the United States. Intelligence-gathering satellites may be particularly susceptible to such measures. For example, terrestrial force elements might employ maneuver to avoid observation by enemy imaging satellites, and they could use camouflage and concealment to prevent recognition if observed. Decoys which would also be "recognized" erroneously could be used to thwart image interpretation by causing confusion as to the numbers and locations of the assets simulated by the decoys. Ships, aircraft, and other assets might be designed to reflect radar signals only weakly in order to evade detection by radar satellites, and radio silence might be practiced, or covert signaling techniques used, in order to prevent detection of radio emissions by satellites. Of course, these passive measures would impose either operational constraints or financial costs or both.

Still other options are available to compensate for, rather than mitigate, the harm which foreign MILSATs could cause to U.S. and allied security. For example, to the extent that foreign MILSATs provide a force multiplier effect to foreign force elements which engage in direct combat, U.S. or allied force elements which might oppose these foreign force elements might be augmented in order to maintain relative combat strength. That is, force augmentation could offset the force multiplication provided to enemy forces by space support. Force augmentation would be costly, but not necessarily more costly than an ASAT capability of comparable security benefit.

These possible responses to threatening MILSAT capabilities are summarized in table 3-3. These response options would be more effectively used in combination rather than individually.

Assessment of the value of ASAT capability is subject to the same methodological difficulties which confound assessment of the value of MILSAT capability.²⁹ These prob-

²⁹The value of a U.S. ASAT capability to the United States in a conflict could be assumed to be equal in magnitude to the

Table 3-3.—Possible Responses to Enemy MILSAT Capabilities

- Force augmentation
 - offsets force multiplication by MILSATs
- Passive measures against satellite reconnaissance and targeting
 - Evasion
 - Concealment
 - Camouflage
 - Decoys
 - Radio/radar silence
 - Covert communications techniques
- Nondestructive anti-satellite measures
 - Electronic countermeasures
 - Jamming
 - Spoofing
 - Electro-optical countermeasures
 - Jamming
 - Spoofing
- Destructive anti-satellite measures
 - Use inherent ASAT capabilities of ICBMs, SLBMs, and ABMs
 - Develop deliberate ASAT weapons

lems, noted above, are discussed in greater detail in appendix D to this report. Although quantification of the value of ASAT capability is necessarily subjective or complicated, or both, it is clear that operational ASAT capabilities would have some value to the extent that they would be inexpensive, stabilizing, and compatible with other (e.g., diplomatic) options for enhancing security.

[negative] total value to the United States of those enemy MILSATs which it would be expected to destroy. No analytically sophisticated studies known to OTA have attempted to systematically assess and compare the utility of U.S. MILSATs to the United States with the disutility of Soviet MILSATs to the United States [but compare Stephen M. Meyer, op. cit., pp. 204-215]. It is these utilities which should be compared to determine whether the United States would fare better in a regime in which U.S. and Soviet MILSATs were mutually vulnerable to the other's ASAT weapons or in a regime in which U.S. and Soviet MILSATs were protected from ASAT threats by active or passive countermeasures or arms control.

MILITARY SPACE POLICY

Military Space Policy Issues

The fundamental task of military space policy formulation is deciding how much proposed military space programs are worth, both in terms of the resources for which they would compete with other proposed national programs, and in terms of opportunity costs which might be incurred by failing to take other actions (e.g., arms control) with which such programs are incompatible for nonbudgetary (e.g., legal) reasons. Because the costs, risks, and benefits differ in character, a political determination of levels at which military space efforts should be pursued is required.³⁰

Prerequisite for this is the task of deciding the *relative* values of proposed military space systems, anti-satellite systems, and arms control agreements; judgment of these values also requires political choice.³¹

³⁰Representative of such determinations are the annual budgets prepared by the executive branch and funds authorized and appropriated by Congress.

³¹Representative of such determinations are President Carter's Presidential Directive 37 (PD-37) issued in June 1978, President Reagan's July 4, 1982, statement on National Space Policy, and President Reagan's *Report to the Congress: U.S. Policy on ASAT Arms Control*, Mar. 31, 1984.

ASAT Policy Issues

Particularly apparent is the incompatibility between ASAT capabilities and ASAT arms control agreements; these would have different kinds of benefits and risks, and a decision to pursue one or the other must be based on a political judgement of their respective expected net benefits. A national *ASAT policy* reflects such a judgement and should attempt to establish goals for national efforts to enhance security by the chosen approach. In particular, a national ASAT policy should:

1. describe *military posture objectives*; it should attempt to answer the question: "What ASAT capabilities do we need, and why?"
2. indicate the extent to which pursuit of security by the chosen approach would probably benefit from increased spending in various areas of *research and technology development*, so that national research and development policy might be formulated cognizant of these potential benefits.
3. establish *ASAT arms control policy*; i.e., it should indicate types of arms control

provisions or agreed confidence-building measures which are judged to be in the national interest, in order to coordinate formulation of negotiating postures, in particular, and foreign policy in general;³² and

4. specify U.S. ASAT employment policy; i.e., it should specify conditions under which U.S. use of ASAT capabilities—especially in conflicts short of declared war—would be deemed justifiable and in the national interest. In addition, if we desire to deter Soviet ASAT attacks, we must arrive at and announce a public policy which we believe will make this deterrence as effective as possible. Whether this policy should be explicit or instead one of calculated ambiguity is a matter of political judgment.

Ballistic Missile Defense as an ASAT Policy Issue

The incompatibility between ballistic missile defense capabilities and ASAT arms control agreements is apparent. Ballistic missile defense weapons which would be capable of attacking ballistic missile components *in space* generally would have some inherent capability to attack satellites at altitudes or ranges comparable to those at which ballistic missile components would be engaged, depending on satellite "hardness." The inherent ASAT capabilities of some possible advanced-technology BMD weapons would be considerable, and any arms control agreement which would attempt to limit the threat of such weapons to satellites must ban or limit such weapons. Hence a restrictive ASAT arms control agree-

ment would also restrict BMD capabilities, just as the ABM Treaty—which limits, by intent, weapons capable of attacking ballistic missiles—also limits ASAT weapons with inherent BMD capability. Of all the opportunity costs which might be imposed on the United States by an agreement to limit ASAT capabilities, restrictions on the development and deployment of BMD capabilities beyond those already imposed by the ABM Treaty are considered most costly by those who believe that exploitation of advanced technology may make possible BMD weapons of great effectiveness.

A more fundamental incompatibility between ASAT and BMD capabilities is physical rather than legal: the most capable BMD systems now envisioned would use space-based sensors, and perhaps also space-based weapons, which would be subject to attack by deliberate ASAT weapons or by BMD or other weapons with inherent ASAT capabilities. Such BMD systems would be effective only if their sensors and weapons could be protected from such ASAT threats at reasonable cost by passive countermeasures, active countermeasures, arms control measures, or a combination of these. If so, perhaps such measures could be used to protect other satellites, or else the functions now performed by other satellites could be performed by secondary mission payloads "piggybacking" on BMD satellites. If not, such BMD capabilities would be of little value, if any, and the opportunity costs which would be incurred by restricting them would be small.

[Chapter 5 of this report contains a discussion of past arms control efforts which had the intent or effect of constraining ASAT capabilities. Other ASAT arms control options are described and evaluated on a provision-by-provision basis in chapter 6 and as packages of provisions in chapter 7.]

³²Representative of such a policy is President Reagan's *Report to the Congress: U.S. Policy on ASAT Arms Control*, delivered Mar. 31, 1984.

Chapter 4

**ASAT Capabilities
and Countermeasures**

Contents

	<i>Page</i>
Organization of This Chapter	49
Current and Projected ASAT Capabilities	49
Generic ASAT System Components	49
Soviet ASAT Capabilities	50
U.S. ASAT Capabilities	55
Possible Advanced-Technology ASAT Weapon Systems	62
Isotropic Nuclear Weapons	62
Kinetic-Energy Weapons	64
Directed-Energy Weapons	66
Possible U.S. Responses to Soviet ASAT Capabilities	75
Reduction of Dependence on Military Satellites	75
Force Augmentation	76
Passive Countermeasures	76
Active Measures	84
Diplomatic Measures	86
Summary of Findings Regarding ASAT Capabilities and Countermeasures	86

Tables

<i>Table No.</i>	<i>Page</i>
4-1. Estimated Costs of the U.S. Air Force Space Defense and Operations (ASAT) Program	62
4-2. Types of ASAT Weapons	63
4-3. A Comparison of Laser Weapons	72
4-4. Passive Countermeasures Against ASAT Attacks	77
4-5. Active Measures Against ASAT Attack	84

Figures

<i>Figure No.</i>	<i>Page</i>
4-1. Generic Components of an ASAT System	50
4-2. Illustrative Components of the U.S. Space Defense System	51
4-3. The Soviet Coorbital Satellite Interceptor	53
4-4. Soviet Anti-Satellite Capabilities	54
4-5. Space Detection and Tracking System	56
4-6. Deep Space Surveillance Systems	57
4-7. ASAT Mission Operations Concept	58
4-8. Mission Control Events	59
4-9. The USAF Miniature Vehicle	60
4-10. ASAT Mission Profile	61
4-11. Artist's Concept of a Neutral Particle Beam Weapon	72
4-12. Artist's Conception of the Space Shuttle Deploying a Neutral Particle Beam Weapon	74
4-13. Cost Comparison: Satellite and RPV Relays for Single-Channel UHF Tactical Theater Communications	76
4-14. Low-Cost Packet-Switching Communications Satellite	83

ASAT Capabilities and Countermeasures

ORGANIZATION OF THIS CHAPTER

A variety of technological options are available for space surveillance systems, stand-off weapons, and weapon and sensor platforms for anti-satellite uses. Current and projected U.S. and Soviet ASAT capabilities, including space surveillance capabilities, are described in the first section of this chapter. More advanced ASAT capabilities which could be deployed by the United States or the U.S.S.R. are described in the second section of this chapter.

Some possible U.S. responses to Soviet development of such capabilities are described in the third section of this chapter. The principal conclusions about ASAT capabilities and countermeasures are summarized in the final section of this chapter. The actual military utility of these capabilities will be discussed in appendix D to this report, which is classified.

CURRENT AND PROJECTED ASAT CAPABILITIES

Generic ASAT System Components

A space defense system could include both passive countermeasures for protecting satellites and an ASAT system for interfering with enemy satellites in time of war. An ASAT system, whether deliberate or expedient, must be controlled by an associated command, control, communications, and intelligence (C³I) system, which itself will have three types of subsystems, as illustrated abstractly in figure 4-1. First is the intelligence collection part—the space surveillance system—which would detect electromagnetic radiation emitted or reflected by a satellite and, using these measurements, attempt to track the satellite and determine its orbit. Careful interpretation of this information may allow characterization of the satellite—i.e., determination of its mass, shape, and other features—and even determination of the function of the satellite. On the basis of this interpretation, information would be communicated over command, control, and communications (C³) links to command and control (C²) centers, where authorities would consider the information in the context of other relevant information and possibly issue orders to *negate* the satellite or to interfere with its functioning nondestructively (e.g., using electronic countermeasures). If so, other

C² elements would generate detailed instructions for an attack, and these would be communicated by C³ links to an ASAT weapon system.

An ASAT system would have either nondestructive ASAT devices such as jammers or other electronic or electro-optical countermeasures, or ASAT weapons capable of damaging satellites (in which case it would be an ASAT *weapon* system), or both. In general, each weapon would consist of a *stand-off weapon* capable of damaging a satellite at a distance and either carried by a *platform* such as a satellite, rocket, airplane, or land vehicle, or else based on the ground at a fixed site. The stand-off weapon could be a kinetic-energy weapon (KEW) such as a gun or a fragmentation warhead, a directed-energy weapon (DEW) such as a laser or particle accelerator, or an ordinary “isotropic” nuclear warhead (so called because it would release roughly equal amounts of energy in all directions).

The weapon platform (if any) would carry the stand-off weapon to within lethal range of a targeted satellite. A highly maneuverable platform could pursue and collide with a targeted satellite; such a vehicle would be a “hit-to-kill” kinetic-energy weapon which would

Figure 4-1.—Generic Components of an ASAT System

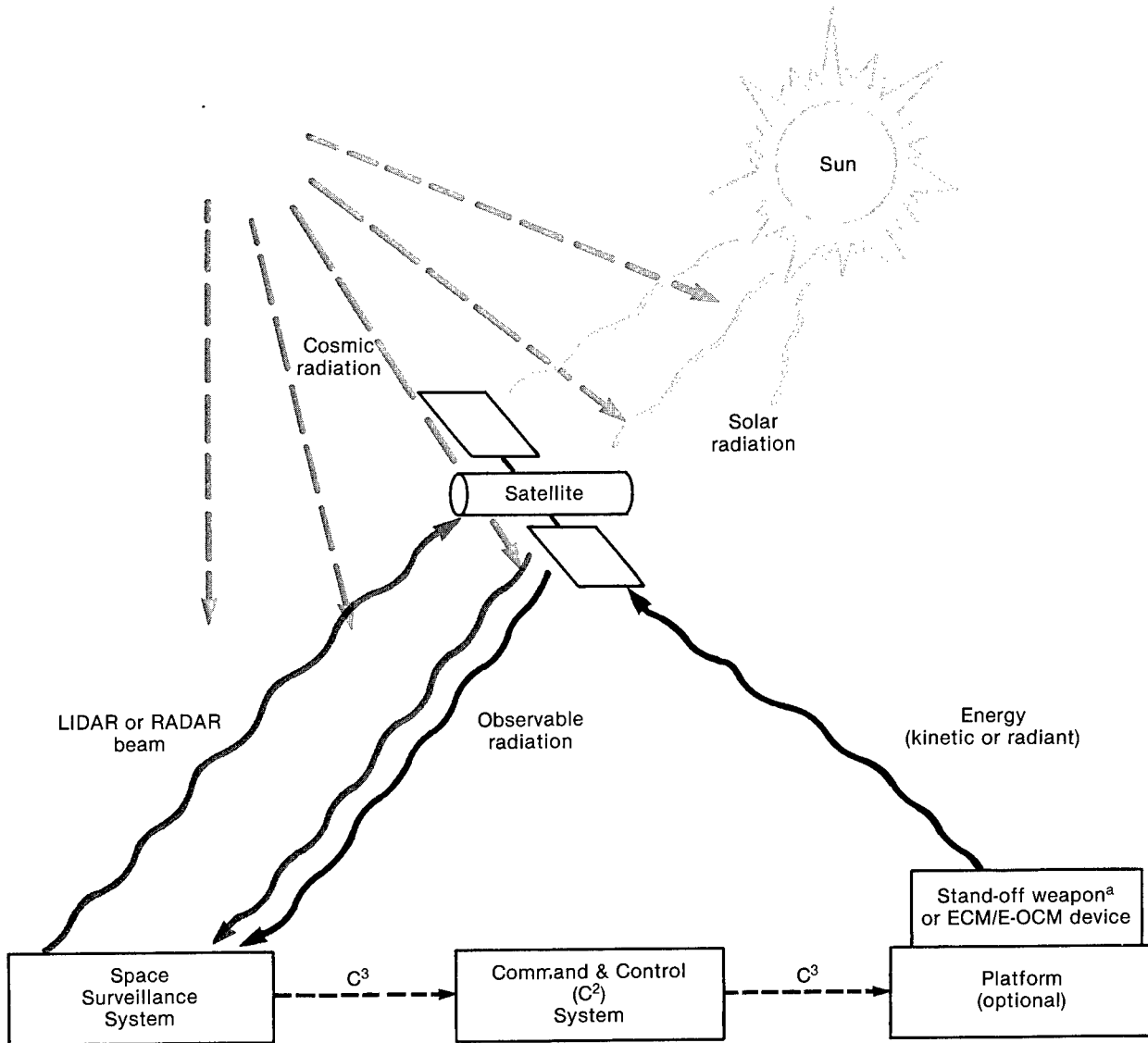

^aDirected-energy weapon, kinetic-energy weapon, or isotropic nuclear weapon.

not need to carry a stand-off weapon. Alternatively, if the stand-off weapon had sufficient lethal range, it would not need to be maneuvered toward a targeted satellite but could instead be based on the ground or on a non-maneuvering platform.

Figure 4-2 illustrates a portion of the U.S. Space Defense System as it will appear when the planned anti-satellite weapon system is

added, showing examples of its space surveillance, command and control, and ASAT weapon systems.

Soviet ASAT Capabilities

Space Surveillance

The ASAT capabilities of the Soviet Union depend on Soviet space surveillance systems.

Figure 4-2.—Illustrative Components of the U.S. Space Defense System

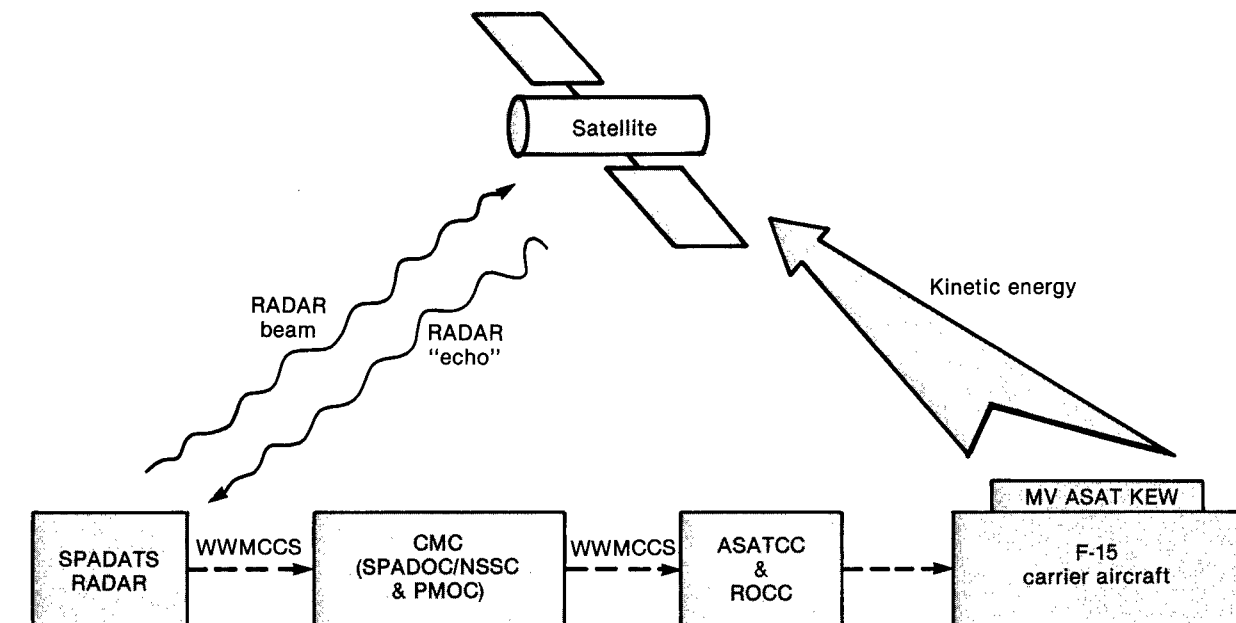

Key:

ASATCC: ASAT Control Center
(ASAT carrier aircraft base: pre-launch C²)

CMC: Cheyenne Mountain Complex

MV: Miniature Vehicle
(satellite interceptor warhead)

NSSC: National Space Surveillance Center

PMOC: Prototype Mission Operations Center

ROCC: Regional Operations [military air traffic] Control Center
(post-launch C²)

SPADATS: SPACe Detection and Tracking System

SPADOC: SPACe Defense Operations Center

WWMCCS: World-Wide Military Command and Control System

The Soviet Union operates extensive military and civil networks of radar, LIDAR¹, and photographic space surveillance sensors linked together by satellite and terrestrial communications systems.² Soviet missile early warning radars and satellites can detect foreign satellite launches. Soviet radio/radar tracking ground stations can presumably detect and track satellites in low-Earth orbit and track satellites in higher orbits. In addition, the ra-

¹LIDAR is an acronym for LIght Detection And Ranging; it refers to a radar-like sensor system which transmits pulses of light, typically produced by a laser, and looks for reflections from objects. Ranges to objects can be inferred from the time delay of pulses reflected from it.

²*Soviet Space Programs: 1976-80*, Part 1, Committee Print, Committee on Commerce, Science, and Transportation, Senate, 97th Cong., 2d sess., December 1982. [USGPO 98-515 O]

dars used by the Soviet ABM system and radio telescopes can be used to detect, track, and characterize satellites. The U.S.S.R. also uses ships for satellite tracking and communications and operates some tracking stations in foreign territory.

Soviet deep-space detection capabilities necessarily rely upon passive sensors, primarily telescopic cameras similar to the Baker-Nunn cameras formerly used by the United States and upon radio telescopes and ground-based military signal intelligence collection³ systems. Passive optical sensors, whether photographic

³Such systems, which perform direction-finding or signal intercept functions, are called electronic support measure (ESM) systems.

or electro-optical, can detect sunlight reflected by a high-orbit satellite; the power of the reflected sunlight received by a distant optical sensor decreases only as the square of the range to the target, so passive optical sensors are more useful than radar for detecting high-orbit satellites.⁴ Similar considerations make passive radio systems—i.e., radio telescopes or military electronic support measure systems—useful for detection and tracking at long range, provided the target is emitting a radio signal of some kind.

It is possible that the U.S.S.R. may develop electro-optical tracking sensors in the future; such sensors could provide surveillance information more quickly than can camera systems, which require development of photographic film or plates. Neither photographic nor electro-optical telescopes can detect or track satellites from the ground in daytime or through overcast, as radar can.

Weapons

The Soviet Union has been conducting a series of tests of coorbital satellite interceptors ("killer satellites") since 1968.⁵ An artist's conception of such an interceptor is shown in figure 4-3. The U.S. Department of Defense estimates that these anti-satellite weapons became operational in 1971.⁶ These weapons are

⁴This is because the energy of a radar return, or "echo," from a satellite decreases as the fourth power of range to the target. Radar returns from satellites in high orbit are generally so weak that they cannot be detected by a radar rapidly scanning the sky; they can only be detected if the approximate position of the satellite is already known so that the radar can scan slowly for signals from that general direction, accumulating signal energy for a prolonged period of time. Hence ground-based radar can measure small changes of a high-altitude satellite's orbit but could not easily find a satellite which had maneuvered energetically since its last observation. Similar considerations limit the effective search range of LIDAR systems.

The energy of a radar echo also depends on the radar wavelength used. For example, at wavelengths much longer than a satellite's diameter, the echo energy decreases rapidly with increasing wavelength—as the inverse fourth power, according to Rayleigh's law. However, the echo also becomes more omnidirectional (as a consequence of Babinet's principle and—in the special case of spherical satellites—the Mie effect) and less dependent upon details of satellite shape and composition other than the electric susceptibility of the satellite, in accordance with Rayleigh's law.

⁵U.S. Department of Defense, *Soviet Military Power*, 4th ed., April 1985.

⁶*Ibid.*, p. 55.

believed to be capable of attacking satellites at altitudes up to 5,000 kilometers or even higher,⁷ depending on their orbital inclinations; presumably they would be unable to attack satellites in orbits with unfavorable inclinations, i.e., very different from the latitude of the interceptor launch site. As of 1984 there appeared to be only two launch pads for Soviet coorbital interceptors, both located at the Tyuratam launch complex.⁸ Several interceptors could be launched per day from this complex.⁹

In 1971 the testing of satellite interceptors was apparently suspended, then resumed in 1976, then again suspended in 1978, just before the U.S.-U.S.S.R. ASAT negotiations began, then again resumed in 1980 after suspension of those talks, then again suspended in August 1983 when Soviet President Yuri Andropov announced a unilateral moratorium on ASAT testing, stating that the U.S.S.R. would not test ASAT weapons if the United States did not. The U.S.S.R. continues to observe this unilaterally declared moratorium. The U.S.S.R. has never officially and publicly admitted developing or testing weapons of this type. However, on 29 May 1985, in an interview by a West German reporter in Geneva, Col. Gen. Nikolai Chervov, a senior department head on the Soviet General Staff, claimed that the U.S.S.R. had successfully developed a direct-ascent satellite interceptor similar to that tested by the United States in the early 1960s and operational until the mid-1970s.

⁷*Ibid.*, p. 56.

⁸U.S. Department of Defense, *Soviet Military Power*, 3rd ed., April 1984, p. 34.

⁹U.S. Department of Defense, *Soviet Military Power*, 4th ed., April 1985, p. 56.

Figure 4-3.—The Soviet Coorbital Satellite Interceptor



Artist's conception of a Soviet coorbital satellite interceptor attacking a satellite.

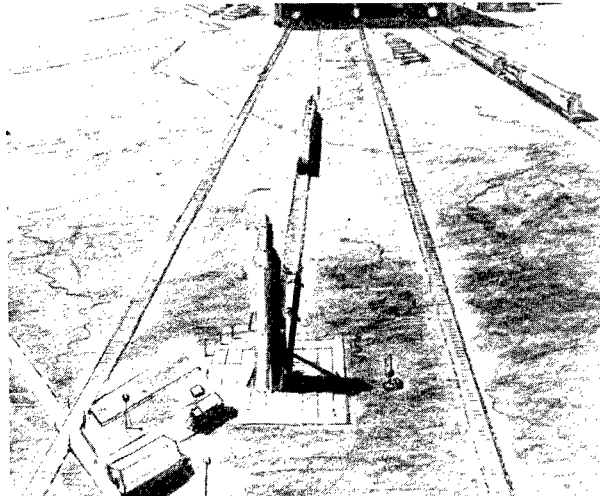

Launchpad and storage facility for satellite interceptors at Tyuratam

SOURCE: U.S. Department of Defense.

The Soviet Union has also been testing ground-based lasers which could have some ASAT capability [see figure 4-4]. The Department of Defense has stated that the Soviets "already have ground-based lasers that could be used to interfere with U.S. satellites." As of 1985, there are two experimental Soviet ground-based lasers with some ASAT capability,¹⁰ both at Sary Shagan.¹¹

In addition to weapons designed specifically for ASAT use, the U.S.S.R. could attack low-altitude satellites with its ABM interceptor missiles [illustrated in figure 4-4],¹² and presumably with ICBMs and SLBMs, although these might require some modification for ASAT use. All of these weapons are presumably armed with nuclear warheads, and their use in a nonnuclear conflict would be viewed as escalatory by the United States and presumably by the U.S.S.R. as well.

In addition to these destructive ASAT capabilities, the U.S.S.R. has a technological capability to jam satellite uplinks or downlinks with some effectiveness, and could use ground-

based lasers for electro-optical countermeasures with some effectiveness.¹³

Operational Capabilities

Existing Soviet ASAT capability could be potentially effective for negating low-altitude U.S. MILSATs, such as those used for navigation (Transit) and meteorological surveillance (Defense Meteorological Satellite Program satellites). Commenting on this capability, the Honorable Richard Perle, Assistant Secretary of Defense (International Security Policy), has stated that:

We believe that this Soviet anti-satellite capability is effective against critical U.S. satellites in relatively low orbit, that in wartime we would have to face the possibility, indeed the likelihood, that critical assets of the United States would be destroyed by Soviet anti-satellite systems.¹⁴

¹⁰Ibid., p. 56.

¹⁴Statement of The Honorable Richard Perle, Assistant Secretary of Defense (International Security Policy), in *Hearings Before the Subcommittee on Strategic and Theater Nuclear Forces of the Committee on Armed Services United States Senate, Testimony on Space Defense Matters in Review of the FY1985 Defense Authorization Bill* [S. Hrg. 98-724], March 15, 1984, Pt. 7, p. 3452.

¹⁰Ibid., p. 56.

¹¹Ibid., p. 58.

¹²Ibid., p. 56.

Figure 4-4.—Soviet Anit-Satellite Capabilities

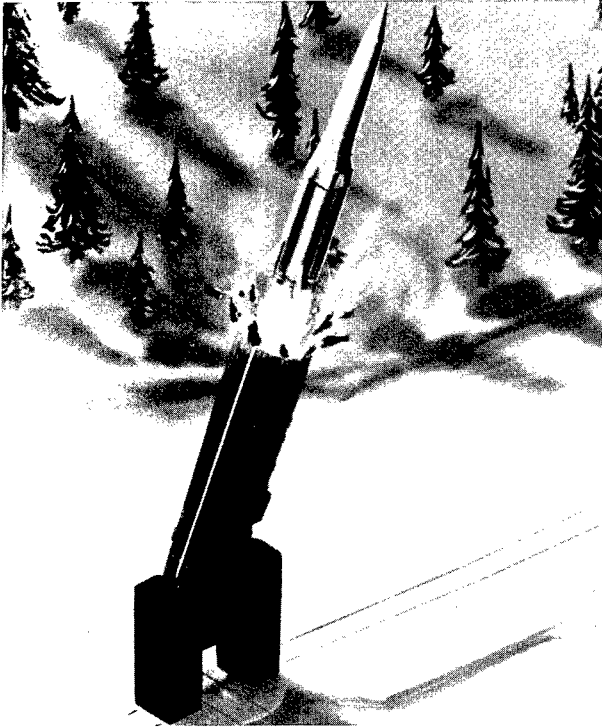

Artist's conception of a Soviet ABM interceptor missile, named GALOSH by Western analysts. GALOSH missiles might have capabilities to attack satellites at low altitudes.

SOURCE: U.S. Department of Defense.

The utility of these U.S. satellites in various types of conflicts is discussed in Appendix D to this report, which is a separate, classified document.

Projected Capabilities

The Soviet Union could develop weapons capable of attacking U.S. satellites at higher altitudes than can be reached by the current Soviet coorbital interceptor. Laser weapons, among other types, could be used for this purpose. The U.S. Department of Defense estimates that:

The Soviets are working on technologies or have specific weapons-related programs underway for more advanced anti-satellite systems. These include space-based kinetic-energy, ground- and space-based laser, particle beam, and radiofrequency weapons. The Soviets apparently believe that these technol-

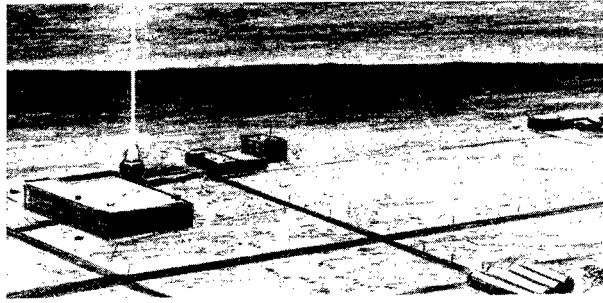

Soviet high-energy laser facility at Sary Shagan. Two lasers there may be capable of damaging unprotected satellites at low altitudes.

ogies offer greater promise for future anti-satellite application than continued development of ground-based orbital interceptors equipped with conventional warheads.

... In the late 1980s, they could have prototype space-based laser weapons for use against satellites. In addition, ongoing Soviet programs have progressed to the point where they could include construction of ground-based laser anti-satellite (ASAT) facilities at operational sites. These could be available by the end of the 1980s and would greatly increase the Soviets' laser ASAT capability beyond that currently at their test site at Sary Shagan. They may deploy operational systems of space-based lasers for anti-satellite purposes in the 1990s, if their technology developments prove successful.¹⁵

The Soviet Union also has the basic technology required to build space-based neutral particle beam weapons. The U.S. Department of Defense estimates that:

A prototype space-based particle beam weapon intended only to disrupt satellite electronic equipment could be tested in the early 1990s. One designed to destroy the satellites could be tested in space in the mid-1990s.^{16 17}

¹⁵U.S. Department of Defense, *Soviet Military Power*, 4th ed., 1985.

¹⁶Ibid.

¹⁷However, as recently as 1984, while projecting this capability, the Administration noted that *We have, as yet, no evidence of Soviet programs based on particle-beam technology* [President Ronald Reagan, "Report to the Congress: U.S. Policy on ASAT Arms Control," 31 March 1984 (UNCLASSIFIED)].

Future manned Soviet spacecraft, such as the expected Soviet "space shuttle"—and, especially, the "space plane"—could have greater maneuverability and possibly non-cooperative rendezvous capability and, if so, some inherent ASAT capability.¹⁸

U.S. ASAT Capabilities

The U.S. Space Defense System is a network of systems used for space surveillance and for command and control. An anti-satellite weapon system will be added to it in the near future. Figure 4-2 illustrates a portion of the prospective U.S. Space Defense System as it will appear the planned anti-satellite weapon system is added. The figure shows examples of the space surveillance, command and control, and ASAT weapon systems which will be part of the U.S. Space Defense System.

Space Surveillance

U.S. ASAT capabilities, like those of the Soviet Union, depend on space surveillance capabilities. Like the U.S.S.R., the United States can use its missile attack warning radars and satellites to detect satellite launches and can track satellites after launch using ground-based and shipboard radar, LIDAR, passive optical, and passive radio sensors. The Space Detection and Tracking System (SPADATS) acquires, processes, stores, and transmits data from such sensors, including Naval Space Surveillance (NAVSPASUR) radar interferometers and Air Force Spacetrack radars and Ground-based Electro-Optical Deep-space Surveillance System (GEODSS) sensors [see figure 4-5]. The United States operates more foreign-based space surveillance facilities than does the U.S.S.R., and consequently relies less on shipboard systems, although such systems are used.

The effective search range of U.S. ground-based radar systems is limited to low-Earth

orbit, although some radars can track a satellite out to geosynchronous altitude if the satellite's approximate position is already known.¹⁹ The range at which a ground-based radar can track low-altitude satellites is limited by the requirement for an unobscured line of sight to the satellite. For example, a satellite at an altitude of 185 kilometers (100 nautical miles) would be below the horizon if farther away than 1,590 kilometers slant range.²⁰

For detection of satellites in deep space the United States relies on a system of telescopic electro-optical sensors called GEODSS, for Ground-based Electro-Optical Deep-space Surveillance System [see figure 4-6].²¹ The GEODSS network, when completed, will provide world-wide deep-space surveillance coverage using sensors at five sites²²:

- Socorro, New Mexico (Site I);
- Taegu, South Korea (Site II);
- Maui, Hawaii (Site III);
- Diego Garcia, in the Indian Ocean (Site IV); and
- Portugal (Site V).

The main telescopes at each GEODSS facility are designed to detect objects as dim as a star of visual magnitude 16.5, or a reflective sphere about the size of a soccer ball in geosynchronous orbit.

Command and Control

Under present policy, the U.S. National Command Authorities (NCA) would have to authorize satellite negation. Actual operational control of a negation mission would be exercised by the USAF Space Command

¹⁸See note 4, supra.

¹⁹I.e., 1,560 kilometers as projected on the Earth's surface. A closer satellite at this altitude might be below the horizon, if mountains or other terrain features obscured the view. In addition, the azimuthal coverage of some radars is limited.

²¹D.D. Otten, E.I. Bailis, and J.G. Klayman, "GEODSS: Heavenly Chronicer," *Quest* (Redondo Beach, CA: TRW, Inc., August 1980), pp. 3-23.

²²Sites I, II, and III are presently operational, and site IV should become operational this year. Sites I, II, and III each have two main 40-inch telescopes and one 15-inch auxiliary telescope, while sites IV and V will have three main telescopes each. Site equipment is designed to be relocatable within 2 weeks.

¹⁸Current manned Soviet spacecraft (Soyuz, Salyut) do not have a significant inherent ASAT capability: they have little maneuver capability and have not demonstrated orbital rendezvous with non-cooperative spacecraft. Rendezvous with cooperative spacecraft is typically performed by an automatic system which relies on a transponder on the passive spacecraft.

Figure 4-5.—Space Detection and Tracking System

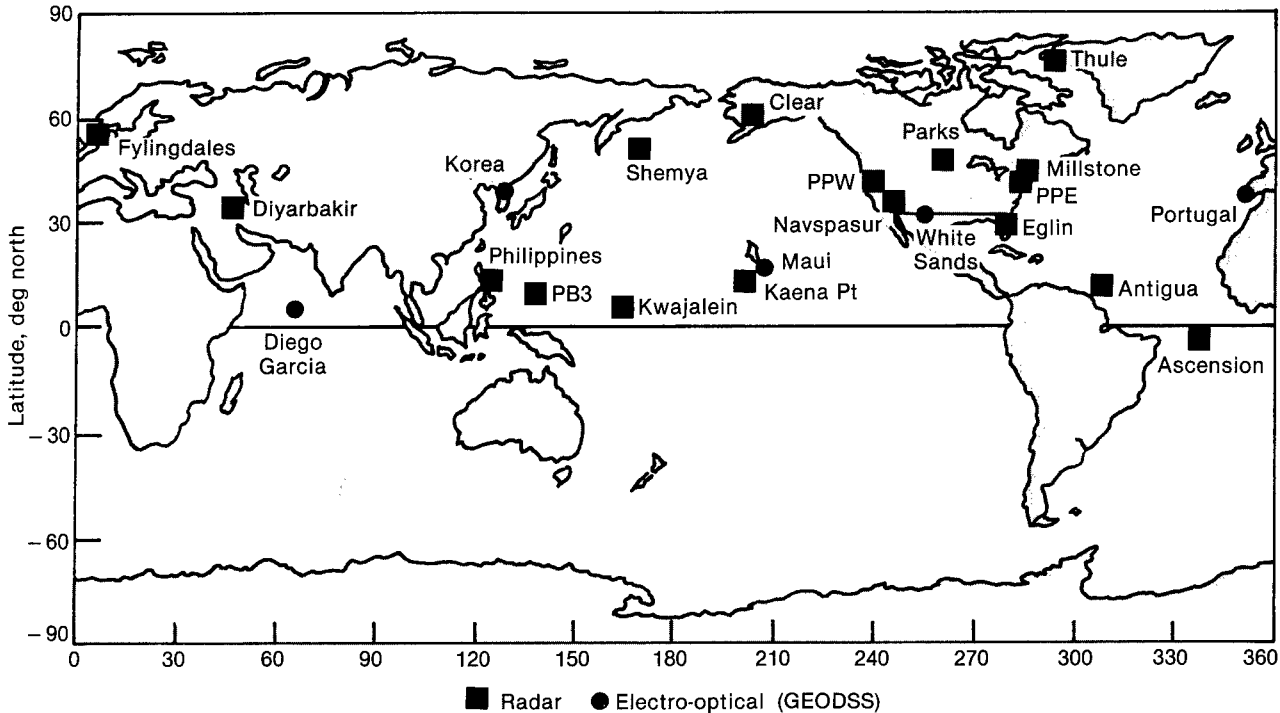

SOURCE: The Aerospace Corp.

Space Defense Operations Center (SPADOC) in the Cheyenne Mountain Complex using other assets of the Space Defense Command and Control System [see Figures 4.7 and 4.8].²³

On October 1, 1985, satellite negation will become the responsibility of a new unified space command which will also exercise operational command over U.S. military space systems which provide support to the combatant forces of other unified and specified commands. Creation of a unified space command was proposed in order to increase the effectiveness and responsiveness of U.S. space systems and to ensure a clear chain of command from the NCA to combatant forces.²⁴ Creation of the U.S. Space Command was authorized by the President on November 30, 1984.

²³R.S. Cooper, Director, Defense Advanced Research Projects Agency, *The U.S. Anti-satellite (ASAT) Program*, statement before the Senate Foreign Relations Committee, 25 April 1984.

²⁴Hon. Verne Orr, Secretary of the Air Force, *USAF FY85 Report to the 98th Congress of the United States of America*, 8 February 1984; reprinted in S. Hrg 98-724.

Weapons

In 1959 the United States successfully intercepted the Explorer VI satellite using an air-launched ballistic missile developed for other purposes and, the following year, began to develop—but abandoned before testing—a coorbital SAtellite INTerceptor system (SAINT) designed specifically for the purpose of inspecting and destroying satellites. The United States also maintained an operational direct-ascent satellite interceptor capability from 1963 until 1975, using nuclear-armed Nike-Zeus missiles (Project Mudflap, 1963-1964) and Thor missiles (Project 437, 1964-1975).²⁵

The United States has no deliberate operational ASAT capability at the present time, although its nuclear-armed ICBMs and SLBMs have some inherent ASAT capabilities, as was demonstrated by the nonnuclear exoatmospheric ABM Homing Overlay Experiment

²⁵M. Smith, "Anti-satellites (Killer Satellites)," CRS Issue Brief IB81123, 22 August 1983.

Figure 4-6.—Deep Space Surveillance Systems



Left: Today, surveillance of deep space is performed by ground-based electro-optical surveillance systems such as the Ground-based Electro-Optical Deep Space Surveillance (GEODSS) system, which is operated by the U.S. Air Force Space Command as part of the Space Detection and Tracking System (SPADATS). Here, an operator at a GEODSS control and display console studies a 2.1° field of view of deep space. On a clear night, a GEODSS main telescope can automatically survey over 500 such fields per hour and detect reflective satellites as small as soccer balls at geosynchronous altitudes.

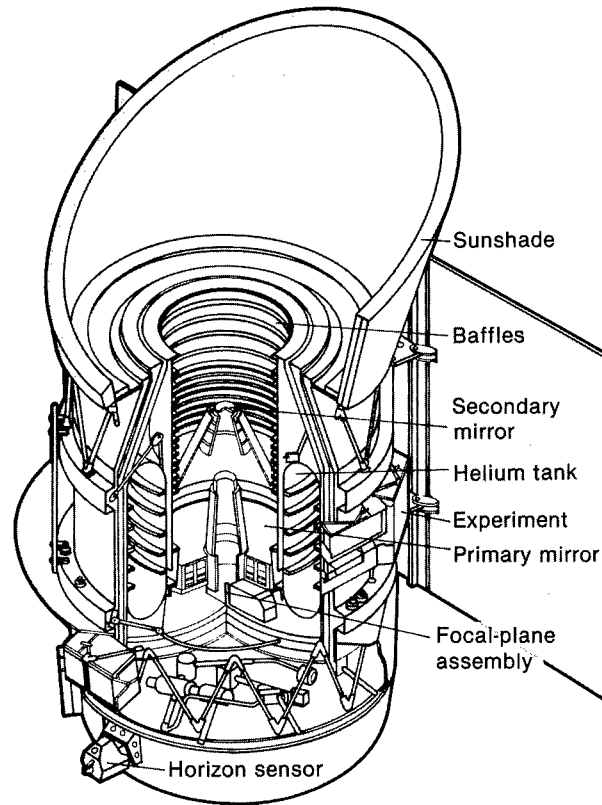

SOURCE: U.S. Air Force.

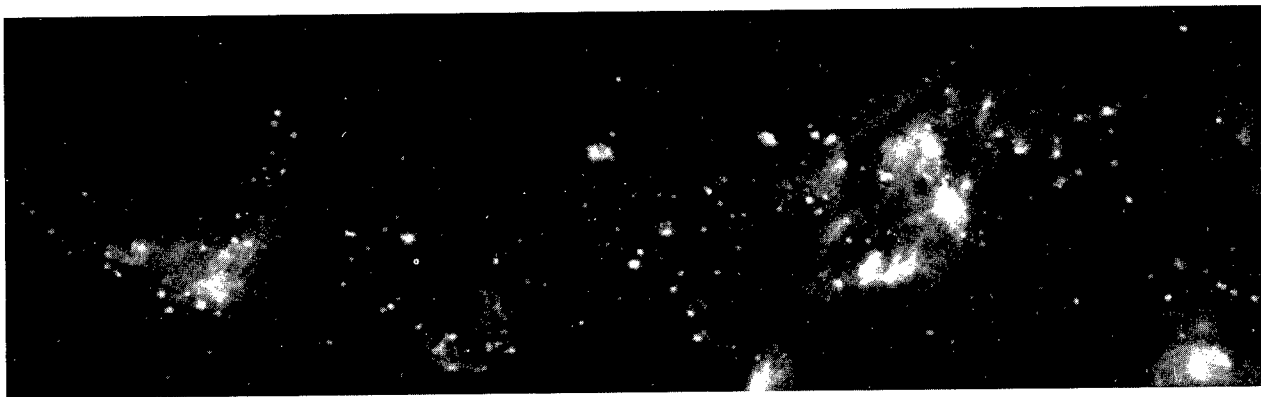

In the future, surveillance of deep space could be performed both day and night, regardless of weather conditions, by infrared telescopes on satellites. Such satellites could use technologies similar to those used in the U.S./British/Dutch InfraRed Astronomical Satellite (IRAS, above right) but would have to be much more capable in order to scan the sky more quickly: IRAS required most of a year to survey most of the sky, including the 28x11° view (below) of a portion of one of the Milky Way's spiral arms.

SOURCE: U.S. National Aeronautics and Space Administration, Jet Propulsion Laboratory.

Figure 4-7.—ASAT Mission Operations Concept

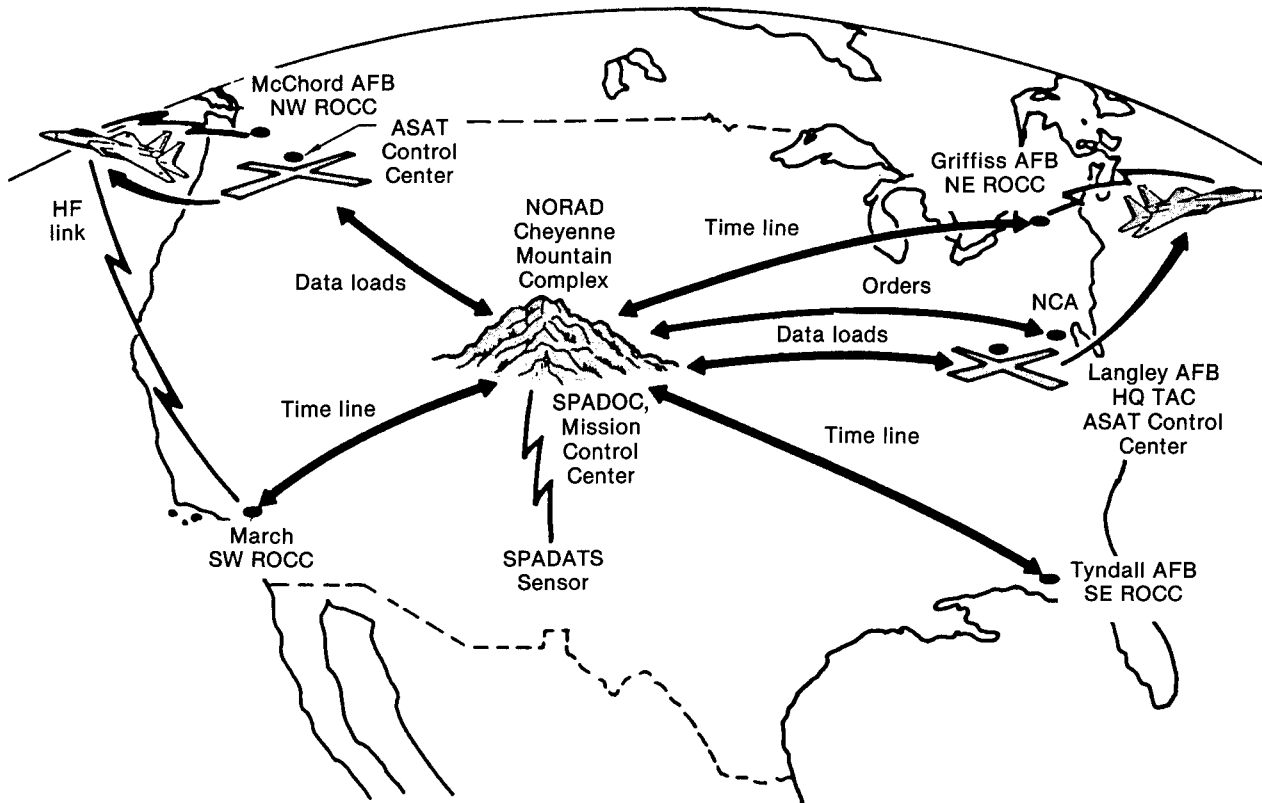

This illustration shows communication links which would be used for a satellite negation operation.

SOURCE: The Aerospace Corp.

(HOE) test of 10 June 1984. However, the U.S. Air Force is flight-testing an air-launched, direct-ascent anti-satellite weapon called the Miniature Vehicle ("MV"). This infrared-guided nonnuclear kinetic-energy weapon [see figure 4-9] is mounted on a two-stage SRAM/ALTAIR booster which is carried aloft and launched from an F-15 aircraft. F-15 carrier aircraft are to be deployed at Langley Air Force Base in Virginia and at McChord Air Force Base in Washington state [see figure 4-10]. When operational, it will be able to attack low-altitude Soviet satellites which perform reconnaissance and targeting functions; these are viewed as most threatening by the United States.²⁶ If based as planned, these weapons will not be able to attack Soviet satellites

²⁶President Ronald Reagan, *Report to the Congress: U.S. Policy on ASAT Arms Control*, 31 March 1984 [UNCLASSIFIED].

which provide missile attack warning, navigation, and advanced communications functions.²⁷

The Air Force plans to hold 12 flight tests of the ASAT system. Two of the twelve tests have been held—the first in January 1984 and the second in November 1984. In the January test, the ASAT missile was targeted at a point in space to determine whether the two-stage SRAM/ALTAIR booster could deliver the miniature homing vehicle to the vicinity of the target point. The Air Force considered the test a success: the proper functioning of the first and second stage propulsion systems and the

²⁷R.S. Cooper, Director, Defense Advanced Research Projects Agency, *The U.S. Anti-satellite (ASAT) Program*, statement before the Senate Foreign Relations Committee, 25 April 1984.

Figure 4-8.—Mission Control Events

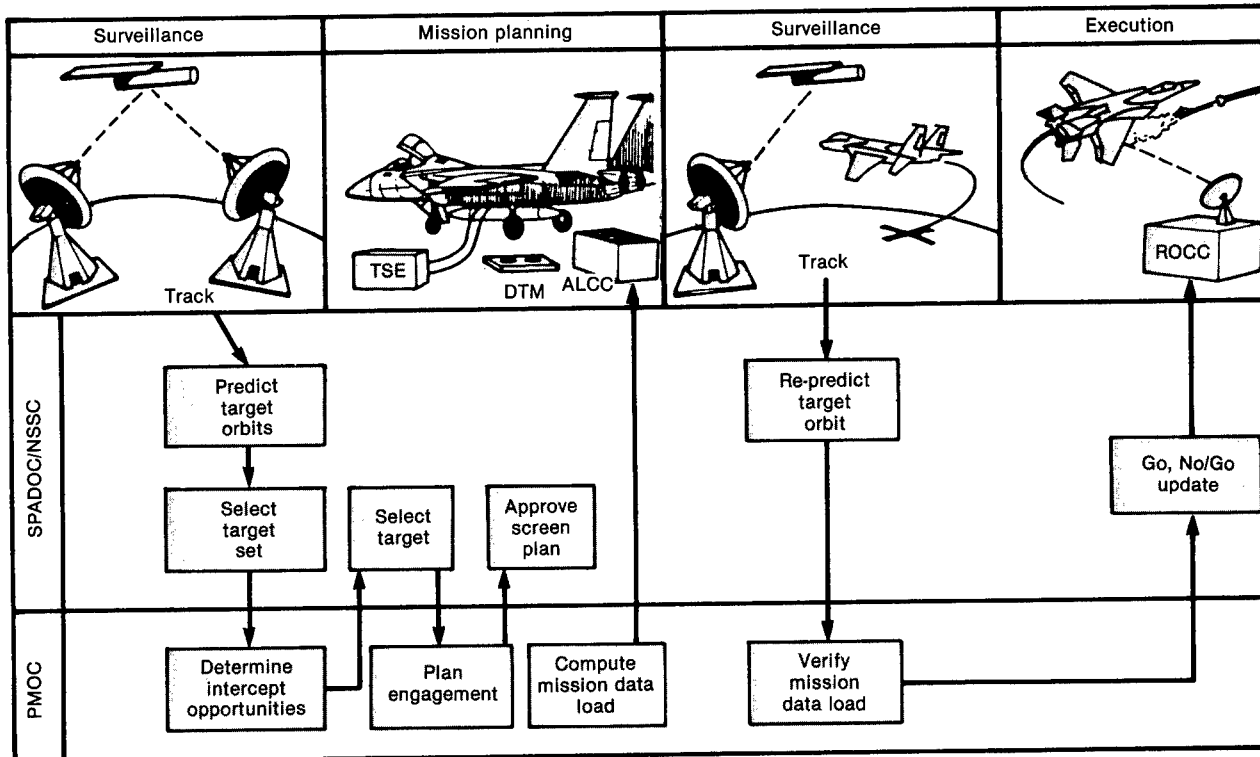

Execution of a satellite negation mission using the USAF MV ASAT weapon would begin with an alerting order. The target would then be tracked by SPADATS and its ephemeris would be updated by the National Space Surveillance Center (NSSC) for use in generating mission tapes to be loaded on the carrier aircraft for targeting of the ASAT weapon. After an execution order is issued from the Prototype Mission Operations Center (PMOC) in the Cheyenne Mountain Complex (CMC), the carrier aircraft would take off and the missile would have to be launched before sensor coolant exhaustion. Before missile launch, the carrier aircraft would receive updated information and instructions by high-frequency radio data link from a Regional Operations Control Center (ROCC), which is an element of the current military air traffic control center.

SOURCE: The Aerospace Corp.

missile guidance system was successfully demonstrated.²⁸

The objective of the November 1984 test was to reaffirm the performance of the missile and to demonstrate the capability of a miniature homing vehicle to acquire and track an infrared-emitting body (in this test, a star) against the radiant background of deep space.

²⁸U.S. Congress, General Accounting Office, "Report to the Honorable George E. Brown, Jr., House of Representatives: Status of the U.S. Antisatellite Program," report GAO/NSIAD-85-104, June 14, 1985.

The Air Force considered the test a partial success.²⁹

Successful completion of U.S. ASAT tests would provide confidence that the weapon could perform as specified if actually used. Funds for completion of the planned flight test program have been appropriated by Congress subject to certain limitations, partly because of concern that once the weapons are proven effective, the Soviet Union would cease to observe its self-imposed moratorium on the testing of ASAT weapons and might be reluc-

²⁹Ibid.

Figure 4.9.—The USAF Miniature Vehicle

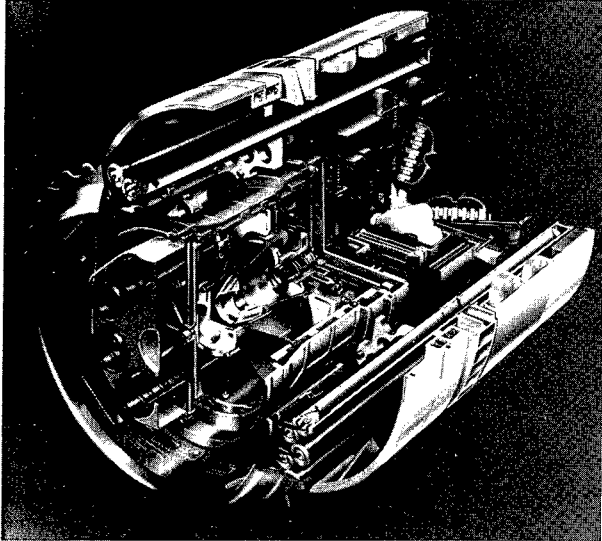

Cutaway view of the ASAT missile warhead (the Miniature Vehicle).

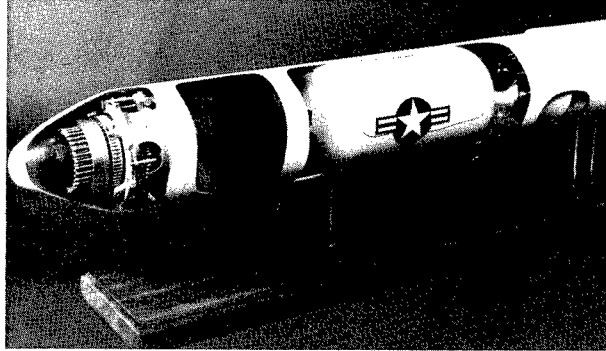

Cutaway view of the ASAT missile, showing MV in nose cone atop ALTAIR upper stage on SRAM (Short Range Attach Missile) booster.

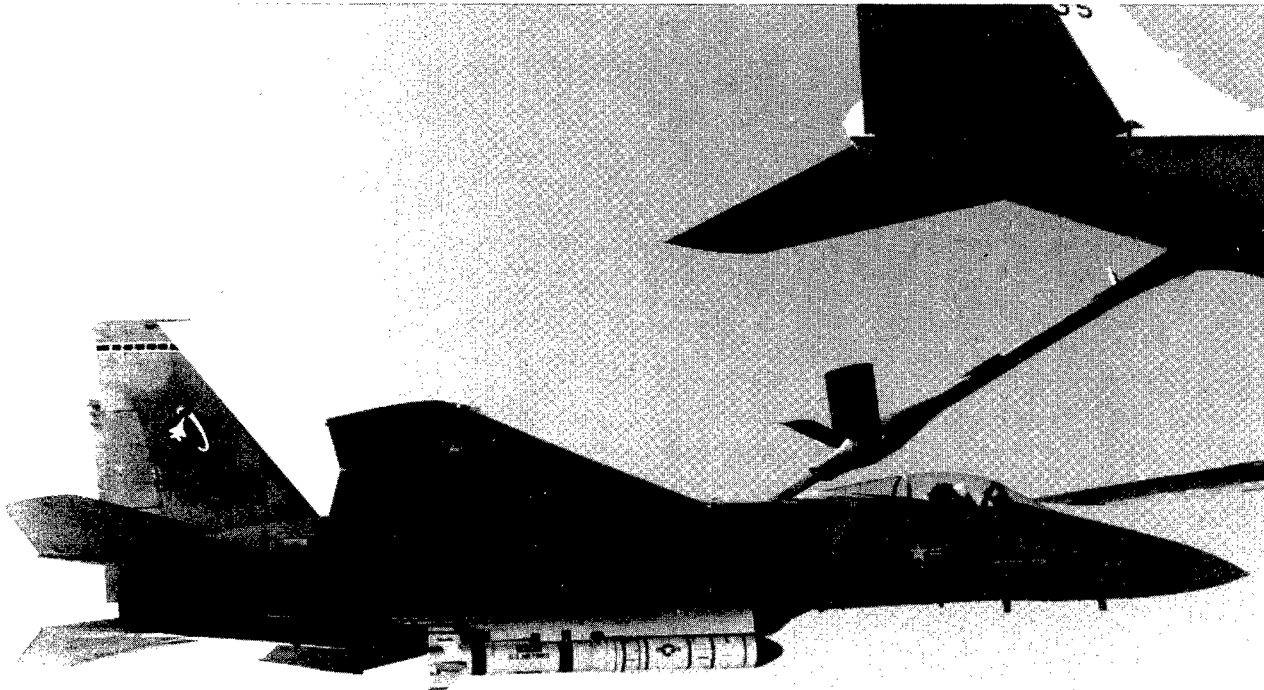

ASAT missile carried by F-15 fighter during refueling operation.

Figure 4-10.—ASAT Mission Profile

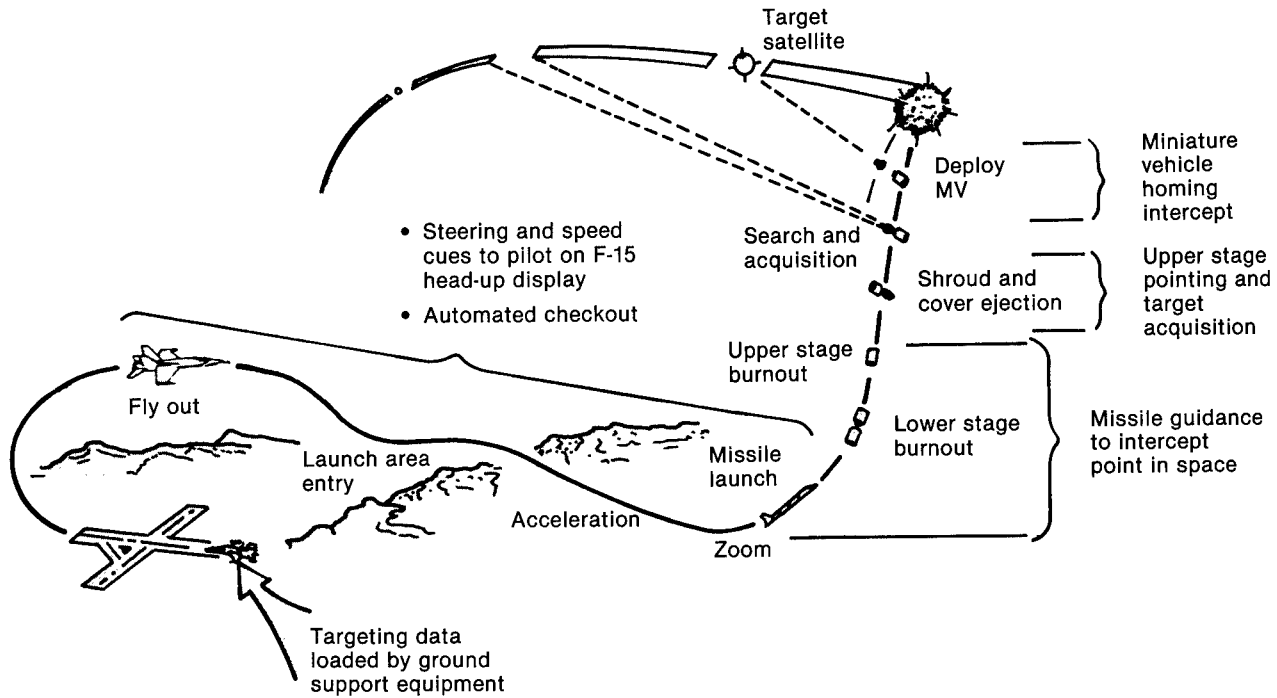

SOURCE: The Aerospace Corp.

tant to agree to arms control measures which would ban them. Because the small weapons could be easily concealed, if they are proven effective and then banned by agreement, Soviet authorities might suspect that the United

States retained a capability to use hidden ASAT weapons.

The estimated costs of the U.S. ASAT program are listed in table 4-1.

Table 4-1.—Estimated Costs of the U.S. Air Force Space Defense and Operations (ASAT) Program

Activity	Cost	Reference
Research, development, testing and evaluation (Program element 64406F)	\$1.40	B 1)
Procurement (missiles and aircraft)	\$2.64	B 1)
Military construction (Program element 12450F)	\$0.04	B 1)
Operation and maintenance, FY 1986	\$0.009	B 2)
Operation and maintenance, FY 1987	\$0.0129	B 2)
Operation and maintenance, FY 1988	\$0.0283	B 2)
Operation and maintenance, FY 1989	\$0.0453	B 2)
Operation and maintenance, FY 1990	\$0.0461	B 2)
Total	\$4.2416	B

SOURCES: 1) U.S. Congress, General Accounting Office, "Report to the Honorable George E. Brown, Jr., House of Representatives: Status of the U.S. Antisatellite Program," report GAO/NSIAD-85-104, June 14, 1985.
2) U.S. Air Force.

POSSIBLE ADVANCED-TECHNOLOGY ASAT WEAPON SYSTEMS

It will be possible in a few years to build space surveillance systems, ASAT weapon systems, and ASAT countermeasure systems much more capable than those used by the United States or expected to become operational soon. These advanced systems could use technologies expected to be available eventually in both the United States and the Soviet Union. The variety of possible systems is so great that this report will discuss only those which seem most promising or threatening with respect to criteria of responsiveness, survivability, altitude reach, economy, early availability, controllable lethality (for destructive applications), and usefulness at nonnuclear levels of conflict. The most promising ASAT technologies will be discussed in this section as possible U.S. options. Space surveillance systems, although essential components of space defense systems, will not be discussed in this section, because the most promising space surveillance technologies would be used to best advantage in space-based space surveillance systems; these were discussed in chapter 3 as possible advanced-technology MILSAT capabilities.

Table 4-2 lists the major categories of ASAT weapons, organized, according to physical means of causing damage, into three categories: isotropic (nondirectional) nuclear weapons, kinetic-energy weapons (projectiles), and directed-energy weapons (particle beam weapons, radio-frequency weapons, and laser weapons). Because the boundary between destructive directed-energy devices (weapons) and nondestructive directed-energy devices (e.g., radio jammers, lasers used to overload optical sensors, or particle-beam generators used to upset the functioning of electronic systems) is blurred, being one of power or mode of use rather than kind, nondestructive directed-energy devices will not be distinguished from directed-energy weapons except where necessary.

Isotropic Nuclear Weapons

Ordinary nuclear weapons, when detonated in space, radiate energy and disperse debris more or less uniformly in all directions. Hence they will be called isotropic nuclear weapons (INW) to distinguish them from nuclear explo-

Table 4-2.—Types of ASAT Weapons

Isotropic nuclear weapons (INW):

Ground-based

—Coorbital interceptor

—Direct-ascent ("pop-up") interceptor

Space-based

—Coorbital interceptor (nuclear "space mines")^{a b}**Kinetic-energy weapons (KEW):**

Ground-based

—Coorbital interceptor

—Direct-ascent ("pop-up") interceptor

Space-based

—Coorbital interceptor (nuclear "space mines")^a—Noncoorbital interceptor^c**Directed-energy weapons (DEW):**

Ground-based

—High-power radio-frequency (HPRF) and active electronic countermeasures (ECM)

—High-energy laser (HEL) and active electro-optical countermeasures (E-OCM)

Space-based

—High-power radio-frequency (HPRF) and active electronic countermeasures (ECM)

—High-energy laser (HEL)^d and active electro-optical countermeasures (E-OCM)

—Neutral-particle beam (NPB)

^aA "space mine" is an expendable ASAT weapon predeployed in space so as to be capable of destroying enemy satellites almost instantly. They could be armed with INW, KEW, or DEW. If armed with a short-range weapon, a space mine must be coorbital.

^bProhibited by the 1967 Outer Space Treaty.

^cIntercepts targets at high velocity from parking orbit.

^dIncluding nuclear explosive powered X-ray lasers (XRLs), which are nuclear directed-energy weapons (NDEW).

sive-powered directed-energy weapons (NDEW) which will be discussed subsequently. INW could be carried to within lethal range of a satellite or satellites by a rocket and detonated. Early U.S. ASAT weapons were of this type, and the United States or the U.S.S.R. could use nuclear-armed ICBMs, SLBMs, and ABM interceptors in this manner. Alternatively, INW could be used as nuclear space mines: they could be concealed aboard satellites which are continuously or occasionally within lethal range of enemy satellites and detonated on command.

As ASAT weapons, nuclear weapons have several legal, political, and strategic disadvantages: they can only be used at the nuclear level of conflict—or in any case their use would escalate a conflict to the nuclear level—and when used they may upset or damage unhardened friendly and neutral satellites at ranges which depend on weapon yield but which can be very large. In addition, they cannot legally be based in orbit, this being pro-

hibited by the Outer Space Treaty of 1967. Moreover, existing U.S. procedures for safeguarding nuclear weapons and for preventing their unauthorized use are expensive and time-consuming, and the Soviet Union may have similar safeguards now and incentives to retain them in the future. On the other hand, the advantages of isotropic nuclear weapons are their present availability, their economy (relative to other weapons of comparable range), their concealability (from present surveillance systems), their great lethal range (as compared to kinetic-energy weapons) against unhardened satellites, the difficulty of hardening satellites against nuclear detonations at close range, and their adaptability for delivery by a variety of launch vehicles and orbital platforms, including those with poor guidance accuracy and no pointing capability.

By comparison, nuclear directed-energy weapons are not now available and, if developed, would require platforms with moderately accurate pointing capability. However, it is possible in principle to build nuclear directed-energy weapons, such as X-ray lasers, which could have far greater lethal range than the nuclear explosive devices which power them and which could be feasibly and economically delivered by platforms with adequate pointing capability. The theoretical potential of such weapons,³⁴ if realized in practice, would make them superior to isotropic nuclear weapons for ASAT applications. The *potential* ASAT capabilities of NDEW, therefore, deserve greater concern than do those of isotropic nuclear weapons which are, however, of more immediate concern because of their existence and *demonstrated* capability.

Existing nuclear-armed Soviet ABM missiles could be used against low-altitude satellites. Prior testing of such weapons against satellites would not be required to demonstrate the reliability of subsystem operation.

³⁴See, e.g., F.V. Bunkin, V.I. Derzhiev and S.I. Yakovlenko, "Specification for pumping X-ray laser with ionizing radiation," *Soviet Journal of Quantum Electronics*, vol. 11, No. 7, July 1981, pp. 971-972, and note that many such lasers could be powered by one "exotic" source of pulsed x-radiation.

Isotropic nuclear weapons concealed aboard satellites used as "space mines" could attack without warning and would pose a greater threat, because reactive countermeasures could not be used for protection. Nuclear space mines could be lethal against satellites as hard as any now operational at such range that the testing of their trailing capability—e.g., in geostationary orbit—although observable, might not be interpreted as such. Protection against such weapons would require evading them during placement (which would be relatively economical only for a small, cheap satellite), opposing their placement by defending an agreed or unilaterally declared "keep-out zone" around satellites from penetration by any spacecraft which *might* contain a nuclear weapon, or possibly, after penetration and trailing by such a spacecraft, evading (e.g., under cover of smoke and chaff) it until out of its probable lethal range, at which time it could be attacked by ASAT weapons of greater range, if available.

Development and, when necessary, operation of close-look inspection satellites equipped with gamma-ray spectrometers or other instruments capable of detecting materials used in nuclear explosives would afford additional protection: if inspection by such satellites were anticipated, the designer of a nuclear space mine would have to shield its nuclear explosive device with tons of material³⁵ in order to prevent collection of *prima facie* evidence of having placed a nuclear weapon in orbit in violation of the Outer Space Treaty of 1967. Placing so massive a space mine into orbit would be more costly, and it could be evaded at less relative cost than a smaller, unshielded space mine could be.

The risk which such weapons may pose to U.S. spacecraft now or in the future is mitigated to some extent by the fact that they would be useful only in a nuclear war, in which the ground segments of space systems would also be significantly vulnerable and might be attacked by preference, and more rapidly. This and the other aforementioned disadvantages of ASAT INW pose disincentives against developing them, attempting to base them in orbit covertly, and using them at nonnuclear levels of conflict.

Several conclusions follow from these considerations:

1. It is feasible to build direct-ascent and coorbital isotropic nuclear weapons.
2. Weapons of this type could be as small and inexpensive as many existing satellites.
3. Such weapons could be developed and tested covertly.
4. Soviet nuclear weapons could threaten U.S. satellites at low and high altitudes now and in the future but only at nuclear levels of conflict.
5. Protection of U.S. satellites from coorbital INW may require defense of a keep-out zone around low-altitude satellites or designing future low-altitude satellites to be at least as small and inexpensive as the nuclear space mines which threaten them. Many more options are available for defending high-altitude satellites from direct-ascent nuclear interceptors.

Kinetic-Energy Weapons

Anti-satellite kinetic-energy weapons pursue satellites and destroy them by direct impact or at close range using a gun or a fragmentation warhead. One example of an ASAT KEW is a coorbital interceptor which approaches its target at a low closing velocity before destroying it. Another example is a direct-ascent ("pop-up") interceptor which is launched from the Earth's surface or from an airplane and which approaches its target at a high closing velocity. Such an interceptor could also be

³⁵U.S. and Soviet scientific spacecraft, landers as well as orbiters, have carried gamma-ray spectrometers capable of detecting low concentrations of fissionable materials as deep as half a meter below lunar and planetary surfaces [U.S. National Aeronautics and Space Administration, *A Forecast of Space Technology 1980-2000*, NASA Special Report SP-387, 1976; and cf. the recent Soviet "VEGA" Venus/Halley's Comet probe.]. The United States could develop such sensors for use on satellites for purposes of monitoring compliance with the Outer Space Treaty.

based in space in a parking orbit, from which it could enter a transfer orbit in which it would close with its target at high velocity, just as a pop-up interceptor would. "Pop-up" interception requires less energy per unit interceptor payload than does coorbital interception, particularly at low altitudes. A coorbital interceptor, on the other hand, could be used as a "space mine," continuously observing and trailing its target, prepared to destroy it almost instantly on command or (if salvaged) when attacked or disturbed in specified ways. Used in this way, a coorbital ASAT KEW could take advantage of the element of surprise in an attack, leaving an enemy no time to react with active defenses or reactive passive countermeasures such as evasion or deployment of decoys or smoke.

A coorbital interceptor could pursue a target (its "quarry") indefinitely if it had as much velocity change capability ("delta-V") as its quarry. If it also had as much acceleration capability as its quarry, it could, with tracking capability, pursue its quarry continuously, otherwise its quarry would be able to maneuver out of lethal range temporarily. Under some conditions, an interceptor may be able to trail its quarry using less delta-V than its target uses for evasion; however, calculation of required velocity change is complicated,³⁶ particularly in the case of many-against-one interception. In any case, if comparable propulsive technologies are available to both pursuer and evader, pursuit can be successful if the interceptor's mission payload—its armament (if any) and guidance and fuzing systems—is lighter than that of its quarry.

It should be possible to build space mines with very lightweight armament. For example, a directional fragmentation warhead similar to that of a Claymore mine could project 100,000 one-gram pellets in a pattern which would cover a 100 x 100 meter area with 10 pellets per square meter at a range of 1 kilometer. This would be adequate to destroy un-

armored satellites as small as about a meter in diameter with high probability. The pellets for such a warhead would weigh 100 kilograms, and its explosive charge could weigh less than that. Even lighter warheads of this type may be possible, possibly having dispersion angles as small as those of shotguns or even high-power rifles (e.g., 10 centimeters dispersion at a range of 1 kilometer).

Guns and rockets could also be used as armament by a KEW space mine. For example, a single unguided rocket which deploys a 10 x 10 meter net weighing about 1 kilogram and having a 1-gram weight at each of its 100 nodes (knots) could achieve the same kill probability as the Claymore-type warhead if its aiming error were less than 5 milliradians (5 meters at 1 kilometer) after rocket burnout and net deployment. A space mine using such a rocket as armament might weigh as little as 50 kilograms but could destroy much heavier unhardened satellites.

It would not be relatively economical to use such mines to attack smaller, cheaper satellites, which could be useful for some military applications, such as communications.³⁷ However, it would be economical to use space mines to attack larger satellites. If such satellites are armored as a countermeasure, the space mine could also be made more lethal, and this would probably require less mass than would be required for armor against it at the assumed lethal range³⁸. There appears to be no relatively economical means of protecting large satellites against a surprise attack by such mines, once they are emplaced. Safety from such attacks would require opposing their placement by defending an agreed or unilaterally declared "keep-out zone" around satellites, or else, once they are emplaced, evading them (e.g., under cover of smoke and chaff) until out of their range, at which time they could be attacked by ASAT weapons of greater range.

³⁶G.M. Anderson, "Differential Dynamic Programming Feedback Control for a Pursuing Spacecraft with Limited Fuel," (New York, NY: American Institute of Aeronautics and Astronautics, AIAA Paper A78-31925, 1978).

³⁷For example, the U.S.S.R. operates a constellation of lightweight satellites in low orbit, and as early as 1961 the United States operated SYNCOM communications satellites weighing only 31 kilograms in geosynchronous orbit.

³⁸See the discussion of hardening in the discussion of countermeasures, below.

Space mines the size of those assumed (2 meters in diameter) could be detected by ground-based radars if at low altitude or, if at high altitude, by electro-optical sensors (e.g., GEODSS) if they do not employ measures (e.g., black paint) to evade detection or by space-based long-wavelength infrared space surveillance sensors even if they do employ such measures. In order to demonstrate reliability, they would have to be tested in space by trailing satellites or space debris. This activity could be observed and would be noticeable.

The U.S. Department of Defense has estimated that the U.S.S.R. views development of directed-energy weapons as a more promising approach for improving future antisatellite capabilities than further development of ground-based kinetic-energy ASAT weapons.³⁹ However, Soviet development and testing of interceptors of the type which is currently operational have demonstrated an interest, and some capability, in coorbital, nonnuclear kinetic-kill approaches to ASAT capability. Given sufficient incentive, the U.S.S.R. might choose to continue these efforts and, if so, could eventually produce smaller, cheaper weapons of longer endurance. Once testing of such weapons in space is observed, there might be insufficient time for the United States to react by developing new generations of small, inexpensive satellites against which use of small space mines would be uneconomical.⁴⁰

It can be concluded from these considerations that it is feasible to build coorbital kinetic-energy ASAT weapons. Weapons of this type could be smaller and cheaper than most satellites as presently designed. If such weapons are deployed by the U.S.S.R., protecting future U.S. satellites from them may require defense of a keep-out zone around U.S.

³⁹U.S. Department of Defense, *Soviet Military Power*, 4th ed., April 1985, p. 44.

⁴⁰For example, Soviet testing of interceptors of the type now operational was first observed in 1968, and the U.S. Department of Defense has judged, in retrospect, that an operational capability with these interceptors was achieved three years later, in 1971. [Ibid., p. 55.]

satellites or designing future satellites to be at least as small and inexpensive as the space mines which threaten them.

Directed-Energy Weapons

Several types of directed-energy weapons could be used for ASAT purposes, including ground- and space-based systems powered by nuclear explosives, nuclear reactors, or non-nuclear energy sources. They include high-power radio-frequency (HPRF) generators, high-energy laser (HEL) weapons, and neutral particle beam (NPB) weapons. They could also include non-laser sources of short-wavelength radiation.

High-Power Radio-Frequency Weapons and Electronic Countermeasures

HPRF weapons—which include high-power microwave (HPM) weapons—are devices capable of producing intense, damaging beams of radio-frequency radiation.⁴¹ HPRF generators could be used to overload and damage satellite electronic equipment at high power levels or, at lower power levels, merely to temporarily overload satellite electronic systems (i.e., for “jamming”).⁴² Radio-frequency (RF) generators could therefore be useful at all levels of conflict.

HPRF weapons could be ground-based or based in space. Ground-based HPRF weapons, unlike ground-based laser weapons, could operate through cloud cover. However, the maximum pulse energy per unit area which can be beamed through the atmosphere is limited.⁴³ Space-based HPRF weapons would not be so limited, but, like ground-based HPRF weap-

⁴¹I.e., electromagnetic radiation at wavelengths of 1 millimeter or longer.

⁴²This continuum of HPRF effects makes distinction between “weapons” and “jammers” difficult. For arms control purposes, however, a distinction could be made based on power-aperture product, as is done in the ABM Treaty. Wavelength-dependence should be considered as well, because at a given power-aperture product, shorter wavelengths can be radiated with greater brightness and deliver more power per unit area at long range.

⁴³The maximum pulse energy per unit area which can be beamed through the atmosphere is limited to about 1 joule per square meter by the phenomenon of dielectric breakdown of the atmosphere, which occurs at higher energy fluence levels.

ons, would have to be very large in order to concentrate their HPRF energy into a narrow beam. Even a relatively wide beam might be able to damage satellites of existing designs at considerable range, but this is uncertain, and hardening satellites against HPRF radiation is possible.

The lethality of HPRF weapons would be less certain than the lethality of other DEW because of uncertainties about target vulnerability, i.e., about the beam energy per unit area required to damage a particular enemy satellite. This will depend on details of the design of the satellite and would be difficult to predict with accuracy even if those details were known. Moreover, even though it is possible in principle to harden satellites to withstand intense HPRF radiation, it is difficult to verify by modeling and simulation, and exorbitantly expensive to verify by testing, the actual degree of hardness achieved. Hence, although many concepts for HPRF weapons have been studied, none of them are as resistant to countermeasures as are some HEL and neutral particle beam concepts.

Radio-frequency generators of lower power will continue to be valuable for providing capabilities to jam and spoof (i.e., deceive) satellite radio systems.⁴⁴ The vulnerability of satellites to jamming and, especially, spoofing, is also uncertain and probably varies greatly among satellites. However, low-power RF generators useful for jamming and spoofing would be much cheaper than HPRF generators; indeed, some existing electronic countermeasure systems could be used against satellite links. Because of the prevalence and ambiguity of these capabilities, it would be difficult or impossible to eliminate the non-destructive ASAT capabilities of ECM systems by means of arms control agreements. Use of passive

electronic counter-countermeasures, when necessary, would be preferred.

High-Energy Laser Weapons and Electro-Optical Countermeasures (Ground-Based)

High-energy laser weapons are devices capable of producing intense, damaging beams of optical radiation⁴⁵ by means of the phenomenon of stimulated emission of radiation. High-energy lasers could be used to permanently damage satellites, or, at lower power levels, to jam optical communication systems and to "dazzle" optical sensor systems (i.e., to overload them, temporarily blinding them). This continuum of effects makes the distinction between "laser weapons" and "active electro-optical countermeasures" one of degree rather than kind and therefore difficult.⁴⁶ Lasers of several types, employing different materials and physical processes and operating at different wavelengths, might be suitable for use as weapons; some of these types are described in the box entitled "Types of Lasers."

HEL weapons could be space-, ground-, air-, or sea-based. Of the many possible types of lasers useful as ground-based ASAT weapons, continuous-wave deuterium-fluoride chemical lasers have been of particular interest because of their simplicity, the maturity of their technology, and the possibility of focusing their infrared beams using mirrors of relatively rough surface quality (compared to that which would be required at shorter visible and ultraviolet wavelengths).

Repetitively-pulsed free-electron lasers and electric-discharge excimer lasers have also been of interest because they would operate at short wavelengths at which small beam divergence angles could be achieved using smaller mirrors than would be required for infrared beams, although they would have to be

⁴⁴Even at very low power levels radio-frequency generators might be able to confuse ("spoof") satellites by beaming deceptive signals at them. Some possible spoofing techniques have been described by Col. Robert B. Giffin, USAF, in *US Space System Survivability: Strategic Alternatives for the 1990s*, National Security Affairs Monograph Series 82-4, National Defense University Press, Fort Leslie J. McNair, Washington, DC, 1982; p. 26. Electronic counter-countermeasures can be used to reduce the susceptibility of MILSATs to spoofing.

⁴⁵I.e., electromagnetic radiation at wavelengths shorter than 1 millimeter.

⁴⁶For arms control purposes, however, a distinction could be made based on power-aperture product, as is done in the ABM Treaty. Wavelength-dependence should be considered as well, because at a given power-aperture product, shorter wavelengths can be radiated with greater brightness and deliver more power per unit area at long range.

Types of Lasers

A laser is described by the lasant material it uses as a source of coherent optical radiation (e.g., deuterium fluoride), the characteristic wavelength or wavelengths at which the lasant emits such radiation, the method of pumping (i.e., energizing) the lasant (e.g., chemical lasers, electric-discharge lasers, optically pumped lasers, gasdynamic lasers, etc.), the source of energy used for pumping (e.g., chemical electrical, nuclear reactor, nuclear explosive, etc.), and its pulse waveform (e.g., single-pulse, repetitively pulsed, or continuous-wave).

Many materials can be used as lasants; these can be in solid, liquid, or gaseous form (consisting of molecules or atoms) or in the form of a plasma (consisting of ions and electrons). Lasant materials useful in high-energy lasers include carbon dioxide, carbon monoxide, deuterium fluoride, hydrogen fluoride, iodine, xenon chloride, krypton fluoride and selenium, to mention but a few. Some of these—e.g., xenon chloride and krypton fluoride—are molecules which cannot exist under ordinary conditions of approximate thermal equilibrium but must be created by special “pumping” processes in a laser.

of higher optical quality. Free-electron lasers can probably be made more efficient than other short-wavelength lasers and could be ground- or space-based. Electric-discharge excimer lasers might be available sooner, but probably cannot be made as efficient as free-electron lasers can be, nor can they be tuned, as free-electron lasers can be, to wavelengths which would minimize beam degradation by atmospheric effects (in the case of ground-based lasers) and optimize target damage.⁴⁷

⁴⁷Soviet laser development has emphasized other technologies than these; the “best” laser technologies for near-term Soviet weapons may differ from those which would be “best” for near-term U.S. weapons. Cf. N.N. Sobolev and V.V. Sokovikov, “The Carbon Monoxide Laser: Review of Experimental Results,” *Soviet Journal of Quantum Electronics*, vol. 2, Jan.-Feb. 1973, p. 305 ff.; M.M. Mann, “CO Electric Discharge Lasers,” *AIAA Journal*, vol. 14, No. 5, May 1976, pp. 549-567; A.A. Stepanov and V.A. Schlegov, “Continuous-Wave Reaction-Product Chemical Lasers (Review),” *Soviet Journal of Quantum Electronics*, vol. 12, No. 6, June 1982, pp. 681-707; and S. Kassel, *Soviet Free-Electron Laser Research* (Santa Monica, CA: The Rand Corporation, report R-3259-ARPA, May 1985);

Such molecules are called **excimers**, a contraction for “excited dimer” (a dimer is a molecule consisting of two atoms).

Free-electron lasers do not use lasants but instead generate radiation by the interaction of an electron beam with a static magnetic or electric field. Loosely speaking, free-electron laser technology resembles and evolved from that used by particle accelerators (“atom smashers”), while other (i.e., **bound-electron**) lasers use lasants heated by electrical current or chemical combustion and resemble fluorescent lamps or rocket engines in some respects. Some lasers use mirrors, lenses, diffraction gratings, or other optical elements to recirculate the laser beam through the lasant in order to achieve adequate amplification; such lasers are called **cavity lasers**, and the arrangement of optical elements used to recirculate the beam is called the laser cavity or resonator. In other lasers, the beam passes through the lasant only once; such cavity-less lasers are called **superradiant lasers**, and the process of single-pass beam generation they use is called **superradiance**, **superfluorescence**, or **amplified spontaneous emission**.

Beams from ground-based HEL weapons would be subject to a variety of phenomena which would disturb their propagation through the atmosphere. These phenomena include absorption, scattering, thermal blooming, dielectric breakdown, and the refractive effects of atmospheric turbulence. Most serious is beam absorption and scattering by clouds: ground-based HEL weapons, unlike ground-based HPRF weapons, could not operate through cloud cover.⁴⁸

⁴⁸Dielectric breakdown is not as serious at optical wavelengths as it is at radio wavelengths. Scattering causes beam degradation, especially at short wavelengths, but is not insurmountably problematic in clear weather. Thermal blooming of a beam focused on a distant satellite can be controlled by phase compensation techniques, or by using a laser which operates at a wavelength at which atmospheric absorption is not severe. A deuterium fluoride laser, for example, operates at such a wavelength and future free-electron lasers could also operate at such wavelengths.

The effects of atmospheric turbulence also pose a serious problem for ground-based lasers: without compensation, the beam of a ground-based laser would diverge at so great an angle that it would be unable to damage anything other than the most sensitive earth-pointed optical sensors on satellites at geostationary altitude. Such compensation appears possible, in principle.

Another serious problem for ground-based lasers is the infrequency with which a low-altitude satellite would pass within view of a ground-based laser site. The interval between such passes might be days or weeks, and, until it exhausted its maneuver fuel, a maneuvering satellite could completely avoid coming within range. Deployment of a large number of ground-based lasers would provide more frequent opportunities to engage satellites and would increase the difficulty and expense of evasive maneuver and of attempts to attack the laser sites. It would also increase the probability that a number of the lasers would not be overcast by impenetrable cloud cover. Of course, such proliferation would be expensive.

An alternative approach would be to base ASAT lasers on ships, which would have some flexibility to remain in clear weather near the ground tracks of high-priority targets and distant from most anti-shipping threats. Another solution to the coverage problem would be to deploy steerable reflectors on satellites to relay the beams from ground-based lasers to targets or to other relay satellites. The operational capabilities provided by such a system would be similar to those provided by space-based laser weapons with an unlimited power supply, except that beam availability would be contingent on the absence of overcast at at least one ground-based laser site and on the survival of both a ground-based laser and an orbital reflector.

A high-altitude satellite, on the other hand, would be within view of a ground-based laser site for a prolonged or indefinite period. For example, a ground-based laser could irradiate a satellite in geostationary orbit continuously, weather permitting.

High-Energy Laser Weapons and Electro-Optical Countermeasures (Space-Based)

The beams of space-based laser weapons would not have to pass through the atmosphere and could damage unhardened satellites at great range. A much smaller force of such lasers than would be required for effective ballistic missile defense could pose a threat to a nation's most critical satellites. However, space-based laser weapons, like other satellites, would be subject to attack by ASAT weapons.

Several types of lasers could be used as space-based laser weapons, each having some particular advantage. For example, of those lasers which could damage satellites by overheating them, hydrogen-fluoride chemical lasers are particularly attractive because of their simplicity, while carbon-monoxide electric-discharge lasers are attractive because of their potentially high electrical efficiency. Free-electron lasers are attractive because they can operate at short wavelengths at which small beam divergence angles can be achieved using small mirrors. Excimer lasers would be bulky and less suitable for space basing.

Space-based lasers of very low power, if of an appropriate wavelength, could dazzle or permanently blind optical sensors used by other weapons for homing guidance or for beam pointing. More powerful lasers could be used to attack and damage a satellite by overheating it and possibly melting its "skin," or tearing its "skin" as a result of the hammer-like mechanical impulse which pulsed laser radiation can generate on a target surface.⁴⁹

⁴⁹The amount of mechanical impulse which a given amount of beam energy can generate can be estimated on the basis of published impulse-coupling models, such as that of P.E. Nielson, "High-Energy Laser-Matter Coupling in a Vacuum," *Journal of Applied Physics*, vol. 50, No. 6, June 1979, pp. 3938-3943, modified to account for the depth to which the beam radiation will penetrate before surface vaporization begins. In *Directed Energy Missile Defense in Space* [OTA Background Paper OTA-BP-ISC-26, April 1984], Dr. Ashton Carter estimated that a laser beam fluence of 20 kilojoules per square centimeter would produce an impulse intensity of 10 kilotaps [10,000 dyne-seconds per square centimeter], i.e., an impulse coupling of 0.5 dyne-seconds per joule. This estimate assumes that the laser pulse is so brief that little heat is conducted to a depth greater than

Space-based reflectors could relay beams from ground-based lasers to a target, or another reflector, beyond the horizon. These could be used in much the same manner as space-based lasers and would be, in effect, space-based lasers with an unlimited fuel supply.

All of these weapons have certain disadvantages, however. They would use large, expensive, power-handling mirrors; they would engage targets sequentially, thus giving other enemy satellites time to use reactive passive countermeasures (e.g., smoke); and they would be subject to attack by expendable, single-shot weapons (INW, KEW, or DEW) against which reactive countermeasures and shoot-back would be ineffective. Hence space-based lasers which can damage one or several targets instantly, without warning, using a single pulse and which are cheap enough to be considered expendable, if feasible, would be most attractive. Because they would exhaust their fuel or destroy themselves as soon as they were used, they would be invulnerable to shoot-back although subject, and possibly vulnerable, to preemptive attack.

One type of laser which might be useful as an expendable, single-shot, space-based weapon is the X-ray laser. X-ray lasers are presently only in the earliest stages of development.⁵⁰ X-ray lasers (also called "x-rasers" or XRLs) could be very simple in design; they might be thin fibers of lasing material powered ("pumped") by intense, pulsed radiation from

the depth to which the beam radiation will penetrate before surface vaporization begins. Longer pulses can produce a much greater impulse coupling. For example, an impulse coupling of 20 dyne-seconds per joule has been measured in experiments using infrared lasers [P. Bournot, et al., "Mesure de la Pression Induite sur une Cible Metallique par une Laser CO₂ Impulsionnel," *Journal de Physique*, Tome 41, Suppl. au No. 11, Colloque C9, Novembre 1980, pp. 81-86].

⁵⁰Successful operation of an X-ray laser was claimed by a Lawrence Livermore National Laboratories group headed by Dennis Matthews at the meeting of the Division of Plasma Physics of the American Physical Society in Boston on October 29, 1984. Their laser operated at two wavelengths near 20 nanometers. The design of the laser is described by D.L. Matthews, et al., in "Demonstration of a Soft X-Ray Amplifier," *Physical Review Letters*, 54:110-113, 1985. More recently, the U.S. Department of Energy has stated that the nation's nuclear-weapons laboratories conducted an underground test of a nuclear explosive powered X-ray laser at the Nevada Test Site laser and achieved lasing [see note 52, infra].

another laser, a nuclear explosion, or some other source. The beam from such a device would diverge at an angle roughly equal to the square root of its wavelength divided by the square root of the length of the fiber.⁵¹

The U.S. Department of Energy is investigating the feasibility of developing nuclear-pumped X-ray laser weapons. Nuclear explosive pumping is of interest because even if only a small fraction of the energy of a nuclear explosion could be converted into X-ray laser beams, it could still be lethal at great range. Most details of this research, except for the fact of its existence, are classified. However, the U.S. Department of Energy has stated that:

1. The U.S. Department of Energy is interested in and is conducting research on certain types of nuclear explosive powered directed-energy weapons (NDEW)—viz., X-ray lasers, visible-light weapons, microwave weapons, and charged-particle beam weapons—as well as on nuclear explosive powered kinetic-energy weapons (NKEW).
2. Underground nuclear tests at the Nevada Test Site have been and continue to be a part of this research.
3. NDEW could engage multiple targets using multiple beams, providing high leverage.
4. NDEW could damage targets at ranges of thousands of kilometers.
5. Nuclear explosive powered X-ray laser weapons would damage targets by means of ablative shock.

⁵¹Provided the square of this angle is greater than twice the cross-sectional area of the fiber divided by the square of its length. For example, a thin, one meter long XRL operating at a wavelength of 20 nanometers would produce a beam with a divergence angle of 100 microradians. This divergence angle is large compared to those achievable by lasers operating at longer wavelengths at which mirrors can be used, and only a small fraction of the energy in a beam diverging at such an angle would be intercepted by a satellite-sized target at a range of thousands of kilometers. X-rays cannot be focussed using conventional lenses and mirrors, but they can be focussed using diffraction gratings and other special optical elements [R.W. Waynant and R.C. Elton, *Proceedings of the IEEE*, vol. 64, No. 7, July 1976, pp. 1059-1092]. Such techniques may be useful for generating X-ray laser beams of very high brightness.

6. Lasing by a nuclear explosive powered X-ray laser has been demonstrated in an underground nuclear test at the Nevada Test Site.⁵²

Weapons powered by nuclear explosions would have several disadvantages compared to nonnuclear weapons: nuclear explosives are banned from orbit by the Outer Space Treaty⁵³, they would require elaborate, costly, and time-consuming command and control arrangements under present U.S. policy, they would be useful only at the nuclear level of conflict or would signal escalation to that level, and they might disrupt radio propagation and damage allied and neutral satellites when used, depending on burst times, locations, and details of weapon design. For these reasons there is also interest in developing expendable, single-pulse non-nuclear laser weapons, if these should prove feasible and economical. Such lasers might operate at short X-ray and gamma-ray wavelengths⁵⁴ or at longer wavelengths (e.g.,

iodine lasers). Non-laser sources of single-pulse directional radiation may also be useful as weapons.

Neutral Particle Beam Weapons

Powerful particle accelerators similar to those used for scientific research, isotope production, and fusion power applications could be used as particle-beam weapons to attack satellites. Because electrically charged particles would travel along spiraling paths within the Earth's magnetic field, electrically neutral particles such as atoms of hydrogen, deuterium, tritium, or heavier elements would be used by such weapons. Because such atoms would become ionized and hence charged if they passed through matter as dense as the upper atmosphere, such weapons must be based in space and are useful only against targets in space, although relatively small weapons of this type could be kept on the ground ready for launch into orbit and, after some on-orbit testing and calibration, for use.

A neutral particle beam (NPB) weapon might consist of a negative ion source, a particle accelerator, beam focusing and pointing magnets, and a "stripping" device—e.g., a gas cell⁵⁵—which strips the negative ions of their extra electrons, thereby neutralizing them, as well as a power source and other ancillary equipment,⁵⁶ as shown in figure 4-11. These components could resemble those presently in use for other purposes and need not be much larger to provide a modest ASAT capability. For example, the hydrogen atoms produced by an accelerator at the Los Alamos Meson Physics Facility (LAMPF) have energies of 800 million electron volts⁵⁷ (MeV) and could

⁵²On January 14, 1983, in the first official public discussion of U.S. research on nuclear explosive pumped X-ray lasers, the Presidential Science Advisor, Dr. George Keyworth, suggested that such lasers might eventually be of great military significance, and he called the "bomb-pumped X-ray laser" program "one of the most important programs that may seriously influence the nation's defense posture in the next decades." [Quoted by William J. Broad, in "Reagan's 'Star Wars' Bid: Many Ideas Converging," *New York Times*, Mar. 4, 1985, p. A1 ff.]. Subsequently, Major General William W. Hoover, USAF (Ret.), Assistant Secretary of Energy for Defense Programs, elaborated on the U.S. nuclear directed-energy research, saying that the nation's nuclear-weapons laboratories conducted an underground test at the Nevada Test Site of an X-ray laser and achieved lasing. More recently, the Department of Energy has released the other statements quoted here.

⁵³Some have, however, questioned this interpretation, arguing that the intent of the Outer Space Treaty was to ban weapons of mass destruction from orbit, not ASAT or BMD weapons which would cause minor collateral damage, if any.

⁵⁴One concept for a short-wavelength X-ray laser envisions using a very brief and intense laser pulse to stimulate coherent, collective radioactive decay of nuclei which have been energized by exposure to neutrons in a reactor [C.B. Collins, et al., "The Coherent and Incoherent Pumping of a Gamma Ray Laser with Intense Optical Radiation," *Journal of Applied Physics*, vol. 53, No. 7, July 1982, pp. 4645-4651]. Recent experimental results [B.D. DePaola and C.B. Collins, "Tunability of Radiation Generated at Wavelengths Below 1 Å by Anti-Stokes Scattering from Nuclear Levels," *Journal of the Optical Society of America B*, vol. 1 December 1984, pp. 812-817.; C.B. Collins and B.D. Paoli, "Observation of Coherent Multiphoton Processes in Nuclear States," *Optics Letters*, vol. 10, January 1985, pp. 25-27] have verified that some of the problems of developing such a laser can be solved. However, it is not yet known whether nuclei suitable for use in such a laser exist.

⁵⁵T.D. Hayward, et al., *Negative Ion Beam Processes*, Los Alamos National Laboratory, report UC-34c, January 1976, UNCLASSIFIED; J. H. Fink, "Photodetachment Technology," American Institute of Physics, Conference Proceedings No. 111, pp. 547-560, 1984; V. Vanek, et al., "Technology for a Laser Resonator for the Photodetachment Neutralizer," American Institute of Physics, Conference Proceedings No. 111, pp. 568-584, 1984.

⁵⁶K. Boyer, "Directed-Energy Beam Weapons," *Proceedings of the Society of Photo-Optical Instrumentation Engineers*, Volume 474, 1984, pp. 79-86.

⁵⁷The electron volt (eV) is a unit of energy; about 6.25 quintillion electron volts equals one joule, the Systeme Internationale unit of energy.

Table 4-3.—A Comparison of Laser Weapons

	Space-based laser (single-pulse)	Space-based laser (repetitive pulse or continuous wave)	Ground-based laser	Ground-based laser and space- based reflectors
Subject to shoot-back by ASAT/DSAT	+ No	- Yes	+ No	- Yes (relay)
Subject to terrestrial attack	+ No	+ No	- Yes	- Yes (laser)
Subject to evasion and reactive deployment of decoys and shielding	+ No	- Yes	- Yes	- Yes
Cost per shot	- High	- High	+ Low	+ Low
Target availability	+ High	+ High	- Low	- Low
Requires survivable space surveillance for targeting	+ No	- Yes	- Yes	- Yes

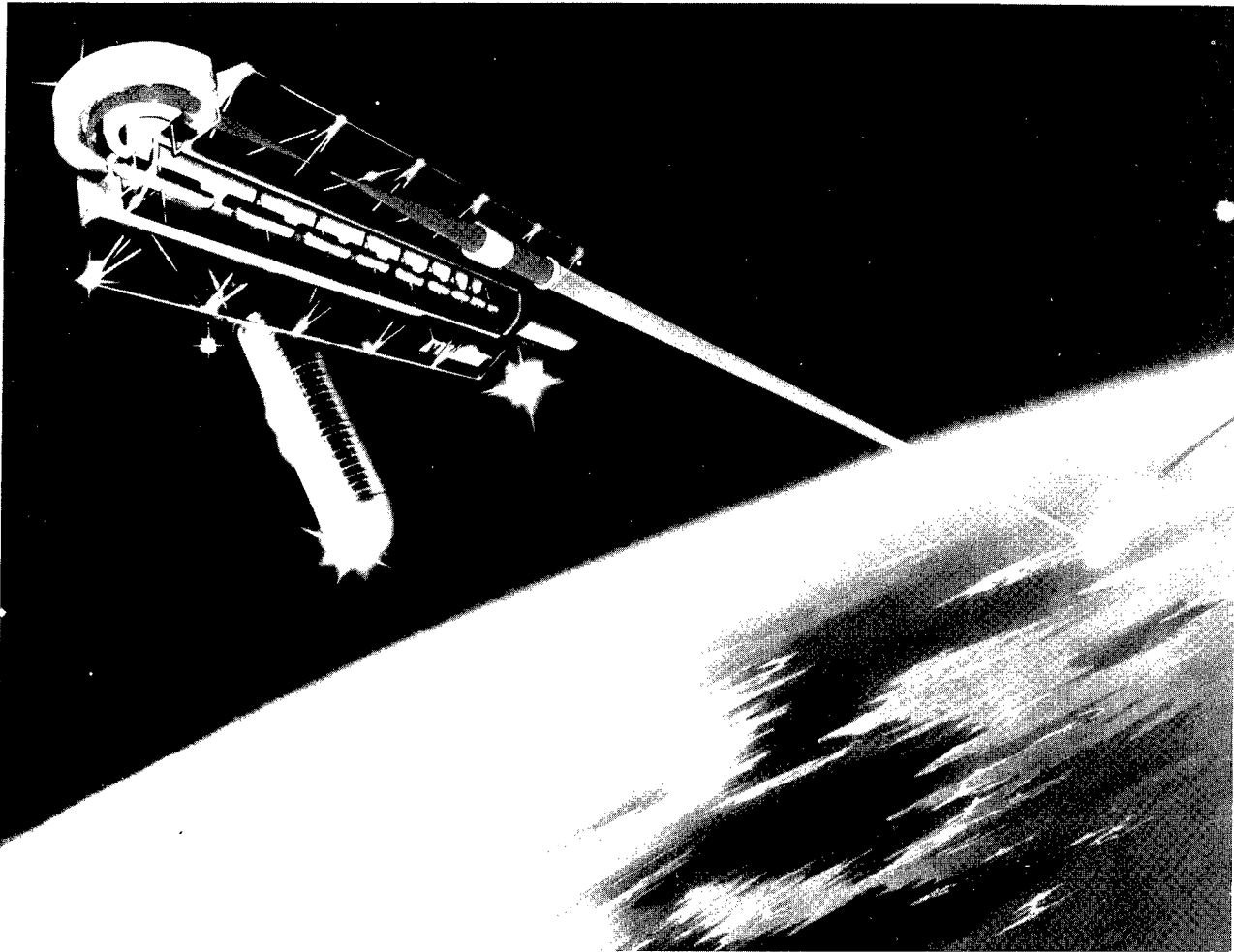
Figure 4-11.—Artist's Concept of a Neutral Particle Beam Weapon

SOURCE: U.S. Department of Energy, Los Alamos National Laboratory.

penetrate aluminum shielding 1 meter thick. The hydrogen atom beam produced by this accelerator has a current of 1 milliampere; irradiation of an unhardened satellite at a range of 40,000 kilometers for several minutes by a beam of this current and particle energy could upset the functioning of its electronic circuits.

A turboalternator-powered NPB weapon might require about 25 tons of liquid hydrogen, liquid oxygen, tankage, and other "overhead,"⁵⁸ to deliver an absorbed dose of 10 kilograys⁵⁹ through shielding at a range of 40,000 kilometers, regardless of the thickness of the shielding, provided that maximum shield thickness is known or assumed in advance and that the weapon is designed to penetrate a shield of such thickness.⁶⁰ An absorbed radiation dose of about 10 kilograys would permanently damage most radiation-resistant high-density silicon integrated circuits. Many existing and planned spacecraft use, or will use, high-density integrated circuitry with a radiation hardness three or four orders of magnitude lower.⁶¹ Ten times this mass—250 tons—would be required to damage circuits hardened to withstand 100 kilograys, at this range.⁶² On

the other hand, only 1.6 tons would be required to damage such circuits at a range of 1,000 kilometers, and perhaps as little as a kilogram would suffice to upset or damage integrated circuits of existing hardness levels at a range of 1,000 kilometers.

Although it may prove possible to harden high-density electronics to withstand 10 kilograys without suffering permanent damage, it is unrealistic to expect that all satellites will be hardened to that extent; transient upset of electronics, possibly causing memory loss in computers, could occur at doses several orders of magnitude lower. Hence a neutral particle beam weapon could attack not only satellites, but decoys for satellites presumed subject to upset, using very little fuel and overhead—e.g., 250 kilograms to deliver a dose of 10 grays at a range of 40,000 kilometers (the distance from low orbit to geosynchronous orbit).

According to some estimates, a NPB weapon with sufficient fuel to operate for 1,000 seconds must weigh about 4 tons per megawatt of beam power.⁶³ The U.S. Space Shuttle, or its expected Soviet counterpart, could deploy into low orbit a NPB weapon weighing as much as 30 tons [see figure 4-12].⁶⁴ A heavier weapon could be launched into low orbit by the anticipated Soviet heavy-lift launch vehicle, which is expected to carry payloads as large as 150 tons. Even heavier weapons could be assembled in space by the United States or the Soviet Union.

A neutral-particle beam could be made to diverge at a small angle and would therefore

⁵⁸Such as fuel for propulsion of the extra weapon fuel, oxidizer, coolant, and tankage.

⁵⁹A gray (Gy) is the Systeme Internationale unit for absorbed energy dose. One gray is one joule per kilogram, or 100 rads. One kilogray is a tenth of a megarad.

⁶⁰A hydrogen atom having a kinetic energy of 50 MeV could penetrate about a centimeter of aluminum shielding. If the thickness of the shield were increased, particle energy, and hence also weapon size, would have to be increased in order to penetrate the shielding, but the amount of beam energy and weapon fuel required need not increase. The reason for this is that as particle energy is increased, beam divergence can be decreased, and the same number of particles per unit area per second could be delivered (over a smaller area) with a lower total beam current (particles per second). Hence a high-energy, low-current weapon could penetrate thicker shielding and deliver the same radiation dose in the same time over a smaller cross-sectional area of a target than could a lower-energy, higher-current weapon of equal beam power (which equals particle energy times beam current).

⁶¹Doses of 100 grays would probably upset electronic circuits on most satellites. It would be possible to shield such circuits, but the shield mass required would increase more rapidly than would the mass of a weapon which could penetrate it. On the other hand, it is possible to fabricate integrated circuits capable of withstanding radiation doses as high as 100 kilograys.

⁶²Low-density gallium arsenide circuits which can withstand 100 kilograys have been fabricated, as have higher-density sili-

con circuits. For example, the Sandia National Laboratories of the U.S. Department of Energy has fabricated a pin-for-pin equivalent of the Intel Corporation's 8085 8-bit microprocessor chip which can function after absorbing a 100-kilogray dose of gamma radiation and can withstand single-event upsets caused by 140 MeV particles. Sandia plans to fabricate a 32-bit silicon microprocessor chip hardened to withstand 10 kilograys.

⁶³E.g., see K. Boyer, "Directed-Energy Beam Weapons," *Proceedings of the Society of Photo-Optical Instrumentation Engineers*, Volume 474, 1984, pp. 79-86.

⁶⁴U.S. Department of Defense, *Soviet Military Power*, 3d ed., 1984, p. 44.

Figure 4-12.—Artist's Conception of the Space Shuttle Deploying a Neutral Particle Beam Weapon

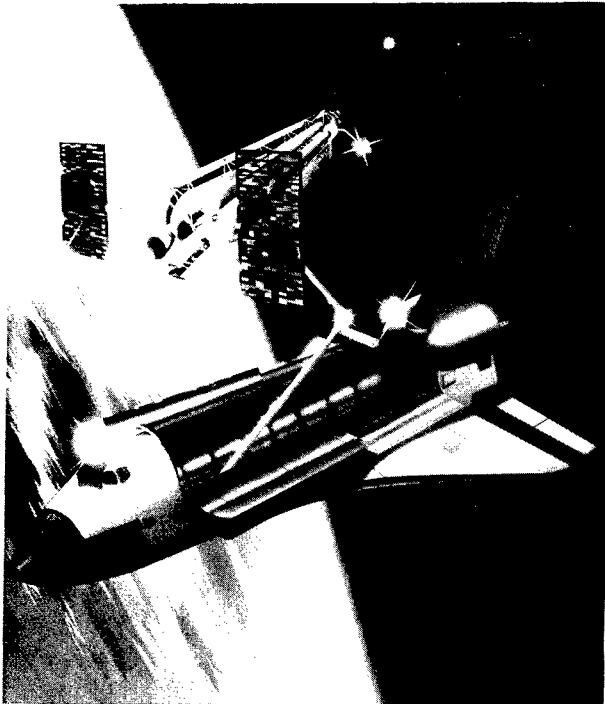

SOURCE: U.S. Department of Energy, Los Alamos National Laboratory.

have a relatively small diameter even at great distances—e.g., 40 meters diameter at a range of 40,000 kilometers. A beam this small must be pointed at a target with an accuracy of about 1 microradian, and this presents a more difficult problem in the case of a neutral particle beam than in the case of a continuous-wave or repetitively pulsed laser. The tracking and pointing systems of such lasers can quickly sense reflected beam energy from targets and thereby determine whether their beams are actually on target. However, a target would emit very little radiation when irradiated by a neutral particle beam. Sensors within several hundred kilometers of a target might be able, during NPB irradiation, to detect enough x-radiation or gamma or other radiation from the target to determine that the target had been hit, but it could not detect such radiation fast enough to correct beam pointing errors based on its presence or absence.

A neutral particle beam weapon could acquire (i.e., detect) a target using a passive long-wavelength infrared (LWIR) sensor; it could then track the target using an active optical tracker (LIDAR) and use this tracking information to determine the angle at which its beam must be pointed at the target. However, this approach only guarantees that the optical tracker is pointed at the target and cannot directly sense whether the beam itself is pointed at the target. That is, **open-loop** pointing must be used for neutral particle beams, while more accurate **closed-loop** pointing can be used by lasers. Determining whether open-loop pointing of a neutral particle beam can be done with an accuracy comparable to beam divergence angles may require testing of neutral particle beam generators in space against instrumented targets.

Aside from these difficulties of pointing and kill assessment, neutral particle beam weapons are among the most promising near-term options for nonnuclear ASAT weapons because of the maturity and demonstrated performance of their component technologies and the relative diseconomy of hardening targets against neutral particle beams. However, neutral particle beam weapons, like other space-based sequential-fire weapons, would be subject to attack by single-shot weapons against which shoot-back and other reactive countermeasures would be ineffective. They would have little operational effectiveness unless their survivability can be assured.

It appears, then, that if accurate open-loop beam pointing can be demonstrated, it will be feasible to build neutral particle beam weapons which, if deployed in low orbit, would pose a serious threat to satellites in low and high orbit. Against this threat only shoot-back would be economical for protecting low satellites, while hardening and deception might protect high-altitude satellites at low relative cost. At close range (1,000 kilometers), neutral particle beam weapons could damage satellite electronics of current hardness levels and upset harder future satellite electronics using

relatively little fuel and tankage (etc.)—probably about 1 kilogram per shot. The cost per shot at a satellite hardened to this level, or at a decoy simulating such a satellite, would be very cheap relative to the cost per satellite or decoy. Hardening satellite electronics would increase the cost per shot, although probably not to the cost of the smallest satellites or precision decoys: damaging high-density electronics hardened to the greatest extent now foreseeable would require about 160 kilograms per shot.

Such weapons, if uncountered, could place low-altitude satellites at risk at relatively low cost. They could also upset or damage unhardened electronics on satellites in synchro-

nous orbit, from low orbit, using little mass per shot (e.g., 25 kilograms for a dose of 10 grays); however, hardening high-density electronics on such satellites to 10 kilograys and using upset-tolerant circuit design could increase the mass requirement for damage to perhaps 25 tons per shot and would increase required irradiation time enough to permit use of reactive passive countermeasures such as generation of smoke or deployment of reaction decoys. Shielding satellites—as distinct from hardening their electronics—would be economically unfavorable against larger weapons: a disproportionately small increase in weapon mass, with no increase in mass per shot, could compensate for an increase in shield mass.

POSSIBLE U.S. RESPONSES TO SOVIET ASAT CAPABILITIES

How might the United States respond to increasingly threatening Soviet ASAT capabilities? Several options are available. For example, an increase in U.S. ASAT capabilities might—but would not necessarily—be an appropriate response. Although useful for attacking Soviet MILSATs, they might be unable to protect U.S. MILSATs. Other possible responses include reduction of dependence on military satellites, augmenting U.S. combat forces (to offset possible loss of force enhancement as a result of an ASAT attack), use of passive or active countermeasures for defense or retaliation, and arms control efforts or other diplomatic initiatives intended to constrain foreign ASAT capabilities or reduce incentives to use them.

Reduction of Dependence on Military Satellites

The United States routinely uses satellites to support its forces deployed worldwide to reinforce allies, protect sea lines of communication, and pursue other national interests. Routine use of satellites for such purposes has engendered a considerable degree of dependence on them. In the past, when satellites

were less expensive and less vulnerable than other means to these ends, dependence on satellites was not risky. In the future, satellites may become so vulnerable that use, if possible, of more expensive but less vulnerable means of performing functions now performed by space systems may be required for adequate security.

Most functions now performed by space systems could be performed by alternative terrestrial systems, although terrestrial systems providing comparable performance of some functions would be unaffordable or politically unacceptable. Missile launch detection and space surveillance could be performed by airborne optical sensors; navigation by advanced inertial navigation systems which can recognize local gravity gradient patterns, nuclear detonation detection by ground-based over-the-horizon electromagnetic pulse (OTH EMP) sensors, and radio communications relaying by MF ground-wave, HF ground-wave and sky-wave, VHF meteor-burst, UHF tropospheric scatter, and UHF/SHF/EHF and light-wave airborne repeaters. Reconnaissance could be performed in wartime by aircraft overflight at great expense and risk.

On the other hand, the kind of information presently collected by satellites in peacetime to monitor compliance with arms control agreements cannot be obtained by other means which are acceptable in peacetime. Unauthorized aircraft overflight, for example, would be unacceptable. However, arms control treaties—like other treaties except those defining “laws of war”—are suspended during war between parties, so a survivable space-based means of performing this function is not required.

Although alternative terrestrial systems for performing some functions may be infeasible or very expensive, alternative terrestrial systems for performing other functions may be only slightly more expensive than space systems. For example, providing intra-theater single-channel UHF communications to mobile ground elements in the 1980s by means of satellite communications transponders would be less expensive than use of remotely piloted vehicles (aircraft) carrying transponders, but only slightly so [see figure 4-13]; a slight increase in satellite vulnerability would make the costs favor use of RPVs. Whether alternative terrestrial systems are worth their cost depends on the function to be performed and is a matter of judgment deserving periodic reconsideration.

Force Augmentation

As satellites have been acquired and integrated into military systems, they have presumably increased the effectiveness of force elements which would engage in direct combat, so that each such force element can now fight as well as, say, one and a half could without MILSAT support. Having become dependent on satellite support, if suddenly deprived of that support the effectiveness of a force element would be reduced, not just to that of a force element unaccustomed to such support but probably more so because of the disorganizing effect of losing sources of information it had come to count on. Nevertheless, it is possible, in principle, to augment current forces so that in the event of sudden loss of MILSAT

Figure 4-13.—Cost Comparison: Satellite and RPV Relays for Single-Channel UHF Tactical Theater Communications

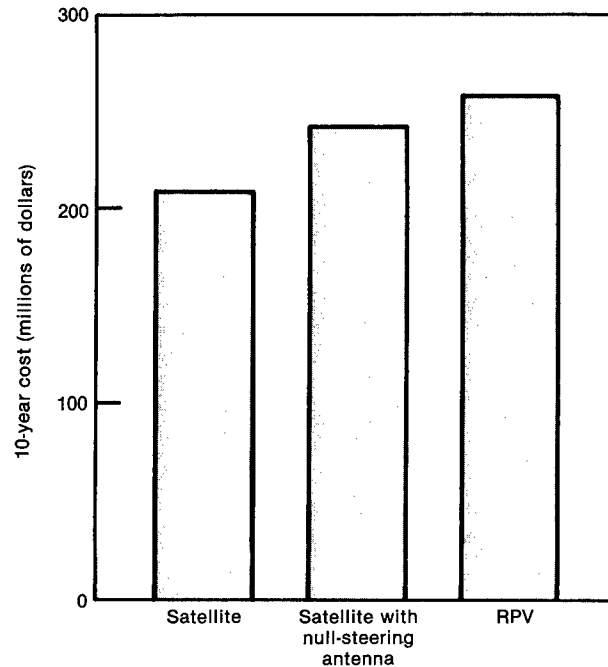

support, larger future forces, although impaired in effectiveness, would fight as well as or better than would current forces using satellite support. The force augmentation required by this criterion might, under some circumstances, be modest.

Passive Countermeasures

“Passive” countermeasures against ASAT capabilities include hiding, deception, maneuver, hardening, electronic countermeasures and electro-optical countermeasures, and proliferation, as well as combinations of these measures [see table 4-4]. Some of these countermeasures—e.g., hardening—are truly passive, requiring no satellite activity for their effectiveness, while others—e.g., evasion—require satellite activity—and hence attack warning—and are not truly passive, although they are nondestructive.

For expository purposes it is convenient to discuss each type of countermeasure in isola-

**Table 4-4.—Passive Countermeasures
Against ASAT Attacks**

Hiding	e.g., satellite miniaturization and orbit selection
Deception	e.g., deploying lightweight decoys
Maneuver	e.g., evasion
Hardening	e.g., use of shielding
Electronic countermeasures and electro-optical countermeasures	e.g., use of shorter wavelengths and more highly directional antennas
Proliferation	e.g., of on-orbit spare satellites

tion from the others in the context of a one-against-one ASAT attack, as will be done here. However, it is anticipated that such countermeasures, if used, might be used in combination in the context of a many-against-many (i.e., force-against-force) space battle. It is in such a context that the potential effectiveness of a countermeasure should be assessed. However, the number and complexity of possible contexts precludes any attempt at assessment of countermeasure effectiveness from being exhaustive or conclusive.

Hiding

“Hiding” measures are measures taken to evade detection by surveillance systems. In some sense the effective use of hiding, if feasible, would be most desirable, because it would eliminate the need for other countermeasures, all of which require increases in on-orbit mass in the form of decoys for deception, fuel for evasion, shielding for hardening, or spares for proliferation.

Different hiding measures are required against different types of surveillance sensors. Space surveillance systems may be of two types: active and passive. Active sensors irradiate a target with electromagnetic radiation in order to “see” it, while passive sensors look for electromagnetic radiation emitted by the target or reflected by the target from natural sources, e.g., the Sun. At optical wavelengths (infrared, visible, and ultraviolet), both active sensors (LIDAR) and passive sensors may be

used⁶⁵ In general, passive optical sensors on satellites in low Earth orbit may be able to detect satellites as small as a meter in diameter at altitudes between a few hundred kilometers and geosynchronous altitude.

Passive LWIR and visible light sensors can work better in combination than either can alone. For example, painting a satellite black would prevent it from reflecting sunlight and thereby make it invisible to passive visible light sensors. However, painting a satellite black would cause it to absorb more solar radiation and become hotter. In thermal equilibrium it would emit more LWIR radiation, making it detectable at greater range by a passive LWIR sensor [see box entitled “Long-wave Infrared (LWIR) Space Surveillance Sensors”].

Operating a satellite at very low altitude can make it difficult to detect using space-based infrared sensors which must view it against the radiant Earth or Earth limb background. More satellites would be required to perform a given function at lower altitude, and user equipment might also have to be more complex and expensive.

Deception

The use of decoys to induce an enemy to waste firepower on false targets—or to withhold fire for fear of doing so—can always be made effective, if the decoys are sufficiently realistic, i.e., “credible” to enemy space surveillance systems. A decoy can always be made credible at a cost less than or equal to that of the satellite it mimics, because a spare satellite could be used as a decoy, and it would be preferable to do so rather than spend as much on a nonfunctional decoy. **The critical question is whether a decoy can be made credible at a much lower cost than that of the satel-**

⁶⁵In most cases passive sensors are preferable to active sensors because they do not require a high-power radiation source for irradiating targets, they are themselves consequently more difficult to detect, and their effective range can be increased more economically, because a twofold increase in range to a target decreases the irradiance received by a passive sensor only fourfold as compared to sixteenfold in the case of an active sensor.

Long-Wavelength Infrared (LWIR) Space Surveillance Sensors

The following discussion describes the physical basis for the estimated detection capabilities of passive LWIR sensors and for the ineffectiveness of hiding measures against them.

Every object emits electromagnetic radiation as a result of thermal processes; the amount of power emitted by an object increases in proportion to its surface area and would increase sixteenfold if its temperature were doubled. A satellite at a typical operating temperature—about 300° K—emits most of its thermal radiation at a wavelength of about 10 microns [10 millionths of a meter], which is in the LWIR portion of the electromagnetic spectrum. The wavelength at which thermal radiation is most intense varies in inverse proportion to the temperature of its source; thus the surface of the Sun—which has a temperature of about 6,000° K—emits thermal radiation (sunlight) which is most intense at a wavelength of 0.5 microns, a wavelength in the visible portion of the electromagnetic spectrum. Passive optical sensors which can detect LWIR radiation can detect the thermal radiation emitted by satellites, while those sensitive to visible radiation are best suited for detecting sunlight reflected by satellites. Visible light sensors are preferred for ground-based space surveillance systems because LWIR thermal radiation is absorbed strongly by the lower atmosphere, although LWIR telescopes have been operated on mountain peaks and on aircraft.

Passive LWIR and visible light sensors can work better in combination than either can alone. For example, painting a satellite black would prevent it from reflecting sunlight and thereby make it invisible to passive visible light sensors. However, painting a satellite black would cause it to absorb more solar radiation and become hotter.¹ In thermal equilibrium it would emit more LWIR radiation, making it detectable at greater range by a passive LWIR sensor. Conversely, making the satellite surface highly reflective would reduce its absorptivity and hence also its emissivity, which equals the absorptivity at each wavelength; this would

make the satellite less visible to passive LWIR sensors.

Passive optical sensors may be designed to detect targets within view above the horizon (ATH) or below the horizon (BTH). BTH detection is more difficult than ATH detection, and the image processing required by BTH sensors is more complicated than that required by ATH sensors. ATH sensors are therefore preferred for passive optical space-based surveillance systems.

Space-based LWIR ATH sensors could not easily detect satellites which orbit at altitudes so low that they are actually within the upper atmosphere. Satellites at such low altitudes would be in the "Earth limb" as viewed by a space-based LWIR ATH sensor, which would have to view the satellite just above the horizon through a thick layer of air which would absorb much LWIR radiation and which would emit, reflect, and scatter LWIR background radiation against which the satellite would have to be viewed. Satellites at such low altitudes would experience considerable atmospheric drag and would slow down and reenter the atmosphere sooner unless they could maneuver and carried enough fuel to compensate for the drag. Operating in such an altitude regime to evade detection by space-based LWIR ATH sensors would also impose operational penalties in some cases. For example, surveillance satellites could not "see" as far from lower altitudes.

Required image processing sophistication would be more difficult for general surveillance than for warning of interception of the satellite carrying the sensor. This is because the spot of focused radiation from an interceptor approaching a satellite-borne sensor "staring" at the celestial background in the direction of the approaching interceptor would not move on the sensor's focal plane, and a single detector element of the sensor could accumulate thermal radiation from the interceptor until sufficient energy for detection has been accumulated. By contrast, the spot of focused radiation from an interceptor traveling in some arbitrary direction would move on the sensor's focal plane, limiting the time available to a detector element for accumulating image energy.

¹S. Sternberg and V.P. Landon, "Satellite Systems" (ch. 17), R.E. Machol (ed.), *Systems Engineering Handbook* (New York: McGraw-Hill, 1965).

If the target's angular position and velocity is approximately known by other means, the number of photons received by each detector element over which the target's image is expected to move could be added in order to accumulate image photons and average out the noise photons. However, if the target's angular position and velocity is not known accurately by other means, the number of possible averages which must be calculated in this way to detect the target reliably increases very rapidly with increasing uncertainty about target position and velocity, and the required mass of image-processing hardware required will increase correspondingly.

A low-orbit LWIR space surveillance satellite with a 1 meter nonemissive primary mirror and a focal plane detector array cooled to 77° K could

lite it mimics, as well as cheaper than an enemy's cost to identify it (e.g., by dispatching a orbital interceptor to observe it at close range) or to attack it in a manner which would negate the satellite it simulates. This critical question remains unanswered.

Before any of these costs can be estimated, the designs of decoys and enemy surveillance and weapon systems must be specified. Many design choices are available. For example, for the same amount of money, a few highly realistic decoys (called "precision decoys" or "replica decoys") could be built, or a much larger number of less realistic but less expensive decoys could be built. A "precision" decoy designed to simulate an on-line satellite would probably have to simulate attitude control, stationkeeping, signal transmission, power generation and heat dissipation, and other observable functions and properties. The subsystems required to do this would be relatively expensive. If such decoys could not be distinguished from actual satellites, all such decoys would have to be attacked in a manner which would damage the satellites they simulate.

detect a black-painted satellite 1.5 meters in diameter at a range of 35,000 kilometers using a 1 millisecond integration (energy accumulation) time. In one millisecond the image of a small satellite at geosynchronous altitude would move across the face of a detector element the size of the telescope's "spot size," if the telescope were on a satellite at 1,000 kilometers altitude and "stared" continuously toward the zenith. It would be feasible and affordable, but costly (several billion dollars), to deploy a constellation of satellites of this performance which stare continuously in all directions above the horizon. Even smaller objects could be detected at greater range using a larger primary mirror, or—less economically in the limit—more image-processing hardware.

Alternatively, inexpensive "traffic" decoys could be made to simulate only those features of a capital satellite which might be measurable cheaply, quickly, and remotely. Reflective balloons or clouds of smoke and chaff could be used as "reaction decoys," i.e., they could be deployed in reaction to warning of an impending attack.⁶⁶ Even if such decoys could deceive an enemy for only a limited period of time, they could be effective in some situations. However, reaction decoys offer no protection against single-shot ASAT weapons (e.g., "space mines") which can destroy satellites almost instantly before reaction decoys can be dispensed. Ingeniously designed lightweight decoys might be both inexpensive and highly credible to passive remote sensors; whether they will be is uncertain.

⁶⁶For example, a satellite under attack by a pop-up infrared-homing interceptor could dispense several lightweight decoys which resemble it, from a distance, in infrared brightness temperature and color temperature. If the interceptor cannot distinguish such decoys from the capital satellite until it has flown past, then the decoys would be adequately "credible." Because satellite mass cannot be measured both quickly and inexpensively, cheap, lightweight decoys could be effective as reaction decoys.

Even if lightweight decoys cannot be recognized as such after prolonged remote passive observation, it might be possible to recognize them using directed-energy devices.⁶⁷ However, use of directed-energy devices in such a manner might be provocative in peacetime and possibly more expensive than the cost of lightweight decoys.

If lightweight decoys cannot be distinguished from actual satellites, all such decoys would have to be attacked, although not necessarily in a manner which would damage the satellites they simulate, because the cost of attacking and observably damaging a lightweight decoy with some types of ASAT weapons could be comparable to, or smaller than, the cost of attacking a decoy in a manner which would damage a satellite which it simulates. For example, ground-based lasers might be able to attack lightweight decoys inexpensively. Neutral-particle beam weapons could also be used to attack decoys at long range, as could single-pulse lasers, although less economically.

The large number of possible designs for decoys and enemy surveillance and weapon systems renders assessment of the cost-exchange ratios⁶⁸ of future systems infeasible at this time. Furthermore, even if the decoy design were specified, it would be difficult to estimate decoy costs accurately. Rough preliminary estimates of satellite cost and of uncertainty in satellite

cost are sometimes derived from estimates of satellite subsystem mass and complexity. However, analysis of historical cost data reveals considerable variation in satellite cost for satellites of comparable small mass.⁶⁹

Deception is more advantageous when used in combination with other passive measures such as hardening and proliferation. For example, dormant spare satellites can be hardened and made to resemble cheaper decoys.

These considerations lead OTA to conclude that the question of whether decoys can be made credible at a much lower cost than that of the satellites they mimic or than an enemy's cost to identify them or to attack them in a manner which would negate the satellites they simulate remains unanswered, and that answering this question is essential in any attempt to assess prospects for making future satellites adequately survivable. An affirmative answer will probably require detailed designs for decoys which are inexpensive and lightweight as well as credible to possible future Soviet surveillance systems.

Maneuver

Satellites may maneuver in order to complicate enemy surveillance and targeting and to evade enemy fire. Satellites which do not *maneuver* are nevertheless unavoidably *mobile*, although in fixed orbits. Because of this property, the relation of maneuver to attrition is different in space than on land or at sea, and proximity in terms of orbital elements (e.g., apogee, perigee, inclination, etc.) has as much tactical significance as does momentary proximity in space. A maneuver, loosely speaking, is an action which changes a satellite's Keplerian orbital elements. Pursuit of another satellite and evasion of an interceptor are examples of maneuvers.

In order to continuously evade an interceptor—whether pop-up or coorbital—a satellite must have an acceleration capability and a velocity change ("delta-V") capability about as

⁶⁷Referring to the possibility of active discrimination of decoys from ballistic missile reentry vehicles, Dr. Gerold Yonas, Chief Scientist of the Strategic Defense Initiative Organization, has written that "directed energy, even in a very early period, could be used in an interactive mode to assist in midcourse discrimination [Gerold Yonas, "Strategic Defense Initiative: The Politics and Science of Weapons in Space," *Physics Today*, June 1985, pp. 24-32; cf. remarks attributed to Dr. Yonas in E.J. Lerner, "Star Wars: Part II—Survivability and Stability," *Aerospace America*, vol. 23, No. 9, Sept. 1985, pp. 80-84].

⁶⁸The relevant cost-exchange ratio is the minimax cost-exchange ratio, i.e., the ratio of decoy costs to Soviet ASAT sensor and weapon costs which would be incurred if decoys were designed to minimize the maximum cost-exchange ratio which the U.S.S.R. could subsequently force on the United States by judicious choice of ASAT sensor and weapon designs. The cost-exchange ratio of a specific future system is of questionable relevance, unless the system can be shown to have a cost-exchange ratio close to the minimax cost-exchange ratio.

⁶⁹There has been less variation in cost per kilogram among satellites of large mass.

great as those of the interceptor, but somewhat more or less, depending on initial positions and velocities.⁷⁰ Acceleration and delta-V can be maximized by minimizing the mission payload, so that a large fraction of the spacecraft's initial mass is contributed by its engines (for acceleration) and fuel (for delta-V). Because an interceptor's payload can be quite small—perhaps comparable to that of a shoulder-fired anti-tank missile—an interceptor might have acceleration and delta-V capabilities which would be much more costly to provide to satellites with large mission payloads such as long-range directed-energy weapons. If so, it would be difficult for such satellites to evade small but sophisticated interceptors.

Hardening

For each type of ASAT weapon, there exist hardening techniques which can reduce the range at which the weapon would be effective. For example, satellites may be hardened to withstand the effects of ordinary, isotropic nuclear weapons by avoiding reliance on photovoltaic cells—which are vulnerable to weapon X-rays—for power, by using massive shielding to block gamma radiation, and by using Faraday shielding, magnetic shielding, and fault-tolerant electronic design to reduce vulnerability to system-generated electromagnetic pulse. Of course, such practices cannot protect a satellite from a nearby nuclear explosion, but they can force an attacker to expend at least one nuclear warhead per satellite and credible decoy to destroy them with confidence.

Shielding, or armor, of different types can offer protection against some types of projectiles, pulsed or continuous lasers, and neutral particle beams. Different types of shields would be required for protection against different types of ASAT threats. For example, shields could be used against projectiles, pulsed lasers, and neutral particle beams, respectively. For example, NASA developed shields to protect a Halley's Comet probe craft

from 0.1 g meteoroids impacting at 70 kilometers per second.⁷¹ Such shields could be all-aspect shields which completely surround a satellite, or they could be "shadow shields" deployed between the defended satellite and a weapon which poses a threat to it. Shadow shields could be deployed on a boom or they could be independent, "free-flying" satellites.

Shadow shields could be lighter than all-aspect shields, but a separate shadow shield might be required for each known or suspected threatening weapon. All-aspect shields would be superior to shadow shields in that they could defend a satellite from multiple sequential or simultaneous attack from any direction or all directions and from covert weapons and they would require no power or warning information for their operation.

Massive shields could also protect satellites from laser radiation and from neutral particle beams. Relatively little shield mass would be required to protect a satellite from beam of low-energy particles (i.e., those having energies of less than 50 to 100 MeV), but the shield mass required would increase sharply if particles of higher energy, produced by larger NPB weapons, were used.

Semiconductor microelectronic circuits inside satellites could also be made more resistant to ionizing radiation such as would be produced by a neutral particle beam. For example, the Sandia National Laboratories of the U.S. Department of Energy have fabricated a pin-for-pin equivalent of the Intel Corp.'s 8085 8-bit microprocessor chip which can function after absorbing a 100-kilogray dose of gamma radiation and can withstand single-event upsets caused by particles with energies as great as 140 MeV.

The use of asteroidal materials such as nickel for large, massive, all-aspect shields has been proposed. Possible advances in space mining, manufacturing, and transportation—which would require large investments—might

⁷¹J.P.D. Wilkinson, "A Penetration Criterion for Double-Walled Structures Subject to Meteoroid Impact," *AIAA Journal*, vol. 7, No. 10, October 1969, pp. 1937-1943.

⁷⁰G.M. Anderson, op. cit.

someday make use of asteroidal material for such purposes cheaper than use of terrestrial material.⁷²

These considerations suggest that, in general, shielding against weapons of relatively low capability is feasible and in many cases may be less expensive than the weapons against which it can offer protection. However, as weapons are made larger, more capable, and more numerous, the cost of protection against such weapons generally increases more rapidly than the cost of the weapons and begins to exceed the cost of the weapons at some point.

Electronic Countermeasures and Electro-Optical Countermeasures

Passive electronic and electro-optical countermeasures can provide protection—analogue to “hardening”—against nondestructive ASAT measures. For example, communication links can be made increasingly resistant to jamming by using more transmitter power (which ultimately becomes uneconomical) or signal bandwidth (which is limited except at extremely high radio frequencies and optical frequencies), or—in some applications—by using larger antennas or shorter wavelengths for greater directionality of transmission and reception, or by transmitting at a lower data rate. Command encryption can prevent spoofing, and use of spread-spectrum modulation and time-division multiplexing techniques can provide significant resistance against uplink and downlink jamming and against downlink exploitation (e.g., by anti-radiation missiles).

Proliferation—Replenishment

Another countermeasure against ASAT attack is proliferation of satellites, so that even if a large fraction of the satellites were damaged by hostile action, enough undamaged satellites would remain to perform their assigned functions. The number of additional satellites needed to assure survivability of a required

number of them would depend on enemy ASAT capabilities. The extra satellites could be placed in orbit or else kept on Earth to be launched into orbit after an ASAT attack to replenish those satellites destroyed by the attack.

Unless on-orbit spare satellites are also deployed, replenishment could not be relied on to maintain uninterrupted performance of satellite function, which is essential for such applications as early warning of missile attack and other strategic command and control functions. If it is cost-effective for an enemy to negate an operational satellite, it would probably be cost-effective for the enemy to negate replacements, if enemy ASAT capability survives. It would also be cost-effective for an enemy to maintain enough ASAT weapons or fuel to avoid exhaustion of ASAT capability before replenished satellites can be negated. Hence replenishment appears unattractive as a countermeasure unless enemy ASAT capability can be destroyed before replenishment is attempted, and unless the satellites to be replaced need not function without interruption.

Proliferation—On-orbit Spares

Spare satellites could also be pre-deployed in orbit, where they could remain dormant until needed or else be used routinely to provide redundant capability in peacetime. Dormant satellites would need to listen for radio commands to activate and might need to report their status occasionally but in general would require little power generation, cooling, attitude control, or exposure of antennas or other sensors while dormant and could be made harder than operational satellites. Their armor could have a simple shape easily mimicked by inexpensive decoys; hence proliferation of on-orbit spares would work more effectively in conjunction with hiding, deception, and hardening measures. However, an enemy which can negate an operating satellite might be able, by the same means, to negate an on-orbit spare once it became operational. Proliferating and simulating dormant spare satellites will not preserve the functioning of a constellation of

⁷²C. Meinel, “Near-Earth Asteroids: Potential Bonanza for Ambitious Military Space Projects,” *Defense Science 2003 +*, February-March 1985, p. 40 ff.

satellites if the spares can be identified and negated quickly and cheaply after being brought "on-line." Hence the use of on-orbit spares would be most attractive if enemy ASAT weapons could be themselves negated soon after space combat begins.

Proliferation—Modularization and Segregation

Another form of proliferation is the partitioning of satellite subsystems into modules which can be segregated and deployed on different satellites. For example, the function of a high-capacity comsat could be performed by several small comsats which pass message "packets" to one another over radio or laser crosslinks.⁷³ Functions such as stationkeeping might be performed by maneuverable satellite "tenders," each of which could visit one satellite after another, adjusting their positions and velocities as needed. Segregation of subsystems would require forgoing economies of scale in peacetime in order to reduce vulnerability.

Combined Passive Countermeasures

Passive countermeasures work better in combination than individually. For example, use of decoys for deception would confer little protection against some (e.g., nuclear) ASAT weapons unless maneuver were used to disperse the decoys. It is therefore important to consider the effectiveness of "packages" of passive countermeasures against various ASAT capabilities, which can also supplement and complement one another and which should also be considered packages, or postures.

Active countermeasures could, and probably would, be used to complement passive countermeasures unless prohibited by a comprehensive ban on possession of ASAT weapons. Hence in hypothesizing ASAT threats to be countered by passive measures alone, it is appropriate to consider as threats only those capabilities which are unlikely to be banned or those which might be developed and deployed (or retained) covertly. The former in-

⁷³The Defense Advanced Research Projects Agency (DARPA) is investigating the feasibility of a packet-switched network of transponders on low-altitude satellites, or on Earth.

Figure 4-14.—Low-Cost Packet-Switching Communications Satellite

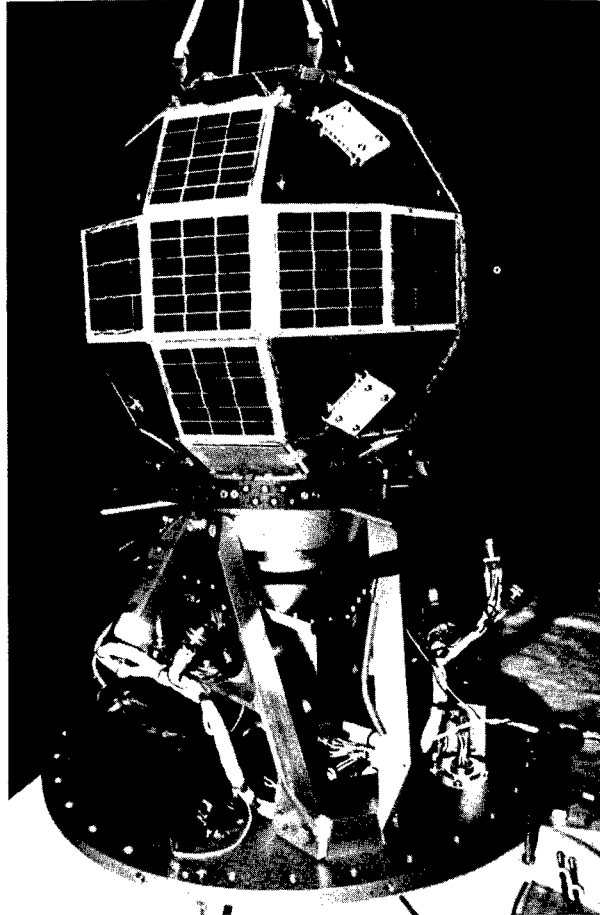

The Global Low-Orbiting Message Relay Satellite (GLOMR), shown here, is designed to receive messages sent to it, store them, and relay them to ground facilities. The GLOMR program of the Defense Advanced Research Projects Agency (DARPA) is intended to demonstrate that communications satellites operating in this manner can be produced at relatively low cost. If sufficiently inexpensive, such satellites could be deployed at lower cost than the cost of attacking them with some types of ASAT weapons, and so many could be deployed that other weapons might require a long time to destroy most of them.

SOURCE: U.S. Department of Defense.

clude nondestructive ASAT capabilities (e.g., ECM and E-OCM), and inherent ASAT capabilities of allowed weapons (e.g., ICBMs); the latter include the existing Soviet coorbital interceptor, direct-ascent and coorbital nuclear interceptors, space-based or pop-up X-ray laser weapons, and possibly ground-based lasers. Of these, the nuclear weapons might be based in space disguised as, or aboard, a different type of satellite, the presence of which would be ob-

servable but the nature of which might be impossible to ascertain except by prolonged close observation or invasive sensing techniques.⁷⁴ In general, nonnuclear space-based weapons could not be expected, with confidence, to perform well, unless they had been previously—and observably—tested in space.

Active Measures

Passive countermeasures against ASAT attacks may be supplemented by active measures intended to deter ASAT attack or to defend satellites if deterrence should fail. Active measures can therefore be used for either defensive or retaliatory purposes. Defensive active measures are *active countermeasures* against ASAT attacks. Retaliatory active measures do not counter ASAT attacks but instead fulfill explicit or implied threats of retaliation which were intended to deter ASAT attacks. Active measures used for either purpose can be either nondestructive (e.g., electronic countermeasures and electro-optical countermeasures) or destructive (e.g., shoot-back), as shown in table 4-5.

Defensive Countermeasures

Shoot-Back.—“Shoot-back” usually refers to counter-attacking space-based ASAT weapons, but can also denote counter-attacks against the ground segment of ASAT weapon systems (e.g., satellite control facilities). Many weapons capable of shoot-back would themselves be subject to shoot-back, making the

effectiveness of shoot-back highly dependent on the types and numbers of ASAT and other weapons deployed and on the incentives for preemptive attack which ASAT weapon vulnerabilities, if any, could create. Analysis of the effectiveness of shoot-back is therefore very complicated in general, although simple in certain important cases.

For example, shoot-back would be ineffective against expendable, single-shot space mines employing kinetic-energy, directed-energy, or nuclear destructive mechanisms. Such weapons would damage their targets almost instantly, if at all, and destroy themselves in the process, leaving nothing of value to shoot back at. Moreover, shoot-back using sequential-fire weapons which are vulnerable to attack by expendable, single-shot weapons would be ineffective, because they could be damaged by single-shot weapons after attacking only one target. However, space-based single-shot ASAT weapons would themselves be subject to preemptive attack—i.e., “shoot-first” instead of “shoot-back.” If such weapons were mutually deployed in space, if each such weapon could instantly destroy several similar weapons and if such weapons were not salvage-fused to fire if disturbed, the resulting preemptive advantage could cause a condition of “crisis instability,” in which each nation, desiring peace but fearing (perhaps mistakenly) an imminent attack by the other, would have reason to initiate hostilities.⁷⁵

However, it is conceivable that even if such incentives should induce escalation from peace or low-level conflict to war in space, the preemptive ASAT attack which would begin such a war might reduce incentives for further escalation, either “vertically” (to higher levels of conflict) or horizontally (to other theaters of conflict, e.g., Earth). For example, if the United States and the U.S.S.R. continue to possess strategic offensive missile forces of considerable counterforce capability, and if each were to deploy a large BMD system

⁷⁴E.g., see U.S. Patent 4,320,298.

Table 4-5.—Active Measures Against ASAT Attack

Defensive measures:
Nondestructive
e.g., jamming
Destructive
shoot-back
attack on ground-based ASAT command and control facilities
Retaliatory measures:
ASAT counterattack
(retaliation in kind)
Horizontal escalation
(to terrestrial theaters)

⁷⁵See M.B. Callahan and F.M. Scibilia, *Proceedings of the Society of Photo-Optical Instrumentation Engineers*, vol. 474, 1984, pp. 107-114.

which relied on vulnerable space-based components, then each nation might fear that the other nation (also fearing a preemptive attack) might attack these BMD components preemptively with some confidence that its BMD system could limit damage from a retaliatory missile attack, if any. Each nation would therefore have an incentive to attack the other's space-based BMD components preemptively. However, after having done so, the attacker would have no motive to launch a preemptive, damage-limiting *missile* attack, because it could assume that the other nation—now highly vulnerable to retaliation—would not seriously consider such an option. Hence, under these assumptions, escalation instability would exist during crises in peacetime (thus “crisis instability”) but not at the level of war confined to space.

It might be supposed that the crisis instability which would accompany mutual deployment of such weapons could be eliminated by salvage-fusing them to fire if disturbed in certain ways (presumably indicative of an attack). If salvage-fusing were feasible and actually used (or believed to be used), there might be little incentive to fire first even if an attack were expected. However, salvage-fusing some types of weapons against some other types may be inordinately difficult or infeasible. Moreover, even though an “intelligent” salvage-fusing system might be able to distinguish among different types of disturbances, it could not be made completely reliable or infallible in discrimination, so there would be a risk that some natural disturbance (e.g., a meteoroid impact) might trigger such a weapon to fire, possibly at several similar enemy weapons, possibly triggering them to fire, etc. Similar consequences could follow an accidental attack or a “catalytic” attack by a third party. Moreover, if salvage-fused space-based weapons only held an enemy's space-based assets at risk, the prospect of losing such assets in retaliation for an attack might be considered an acceptable or favorable trade by a nation less dependent on space assets.

Regardless of whether salvage-fusing were employed, mutual deployment of single-pulse

weapons would not be expected to create strong proliferation incentives: with mutual salvage-fusing each side could plausibly lose all its important space assets in such an exchange regardless of whether it had many such weapons or only a few deployed; it would therefore have no incentive to deploy more weapons than would be required to negate all threatening satellites *except* single-pulse ASAT weapons, against which neither preemptive attack nor shoot-back would be effective. Without salvage-fusing, the side which failed to preempt could plausibly lose all its important space assets in such an exchange regardless of whether it had many such weapons or only a few deployed, and would therefore gain nothing by deploying many weapons.

Electronic Countermeasures and Electro-Optical Countermeasures.—Active electronic and electro-optical countermeasures (jamming, blinding, and spoofing) could be used against some near-term ASAT command uplink systems, KEW homing systems, and DEW acquisition, tracking, and pointing systems which have inadequate counter-countermeasures.

Attack on Ground-Based ASAT Weapons or Support Systems.—At present there appear to be only two launch pads for Soviet coorbital interceptors, both at Tyuratam, and only two Soviet ground-based lasers of significant ASAT capability, both at Sary Shagan. Hence attacking such ground-based facilities with conventional or nuclear weapons could be very effective, especially if preemptive, but would be viewed by some in the United States as escalatory with respect to attacking or defending satellites using nonnuclear weapons.

Retaliatory Measures

The ability to respond to ASAT attack by active measures could be maintained and publicized in an attempt to deter such an attack in the first place. Postures and policies intended to enhance deterrence could act as adjuncts to or substitutes for active and passive countermeasures. Even in the event of deployment of advanced ASAT weapons such as expendable single-pulse lasers against which

“shoot-back” and passive measures might be ineffective, postures and policies intended to enhance deterrence could enhance security, although they cannot guarantee security.

In pursuing security through deterrence, it is appropriate to develop retaliatory capabilities which place at risk targets of sufficient value to deter attack and which do not exacerbate crisis instability. The first of these considerations implies that to deter ASAT attack, retaliation need not necessarily be “in kind”—i.e., against satellites. In fact, an ability to retaliate in kind, however thoroughly or swiftly, would be inadequate to deter an ASAT attack if the attacking nation valued destruction of enemy satellites more than survival of its own. For example, if the U.S.S.R. developed a capability to quickly destroy all on-orbit U.S. satellites, then even if the United States could destroy all on-orbit Soviet satellites in retaliation, the U.S. capability to mount such a retaliatory response—although valuable in the event—might not deter a Soviet first use of ASAT weapons. Soviet leaders might judge the continued deployment of U.S. MILSATs to be more detrimental to Soviet interests than survival of Soviet MILSATs is valuable to Soviet interests. If this were the case, an ability to retaliate against [more valuable] terrestrial assets would be required to successfully deter an ASAT attack. Such retaliatory capabilities might be provided by terrestrial or space-

based weapons. [A separate, classified appendix to this report (Appendix D) contains a more detailed discussion of the utility of military satellites to the United States and to the U.S.S.R.]

The second consideration—avoidance of crisis instability—precludes reliance on destabilizing weapons to provide retaliatory capabilities. Space-based ASAT weapons capable of instantly destroying several satellites, including similar ASAT weapons, would be most destabilizing unless salvage-fused but would be prone to accidental firing if salvage-fused. By comparison, an ideal weapon for deterring ASAT attack would be nonnuclear and hence usable at all levels of conflict without escalating the level of conflict. It could survive a preemptive attack and destroy enemy assets of sufficient value to deter an attack while causing little collateral damage.

Diplomatic Measures

In addition to the military measures discussed above, diplomatic measures such as arms control initiatives and negotiation of “rules of the road” for space operations could be useful responses to foreign development of threatening ASAT capabilities. The variety of possible measures is great, and assessment of their advantages is complicated; this topic is discussed in detail in chapter 6.

SUMMARY OF FINDINGS REGARDING ASAT CAPABILITIES AND COUNTERMEASURES

The most important conclusions which may be drawn from the preceding discussion of ASAT capabilities and countermeasures are:

1. Nonnuclear ASAT weapons which are now deployed or being tested by the United States and the U.S.S.R. are limited in altitude capability and responsiveness and can attack only a subset of currently deployed opposing MILSATs, although this subset includes important MILSATs.

2. The inherent ASAT capabilities of existing nuclear weapons such as U.S. and Soviet ICBMs and Soviet ABM interceptor missiles are substantial. Such weapons could pose a threat even to satellites in synchronous orbit, but are useful only at the highest levels of conflict.

3. Technologies applicable to future ASAT weapons are so varied, and many so promising, that future ASAT weapons, if developed, would be able to attack and dis-

able virtually all MILSATs of current types as currently deployed. Hence to maintain the survivability of constellations of future MILSATs, it will be necessary that the development and deployment of such weapons be constrained by arms control or that future satellites be protected from them by passive or active countermeasures, or that a combination of these approaches be pursued.

4. Of individual passive countermeasures which might be used against advanced ASAT weapons, only deception (use of decoys) is likely to be effective against all types of ASAT weapons, and deception is likely to be economical (relative to the offense) only if the decoys, and the satellites they mimic, are lightweight and inexpensive. Use of deception in combination with maneuver, hardening, and proliferation might offer economical protection for lightweight satellites.
5. Active countermeasures—electronic countermeasures, electro-optical countermeasures, and shoot-back—would be ineffective against an aggressive or preemptive surprise attack using expendable, single-shot ASAT weapons (e.g., kinetic-energy, directed-energy, and nuclear “space mines”). Actively defending keep-out zones around critical satellites might be able to protect such satellites against emplacement of short-range space mines but not against advanced, long-range space mines.
6. Of future ASAT weapons now foreseeable, those which would be most effective if used in a preemptive or aggressive surprise attack—i.e., expendable, single-shot ASAT weapons—would be space-based and therefore subject to such attacks by similar weapons. The cost of protecting them from such attacks—which must necessarily be by passive means—would exceed the cost of attacking them. Such weapons, if mutually deployed, would provide or increase incentives to attack preemptively in crises in which similar attacks are anticipated. Salvage-fusing such weapons to fire if disturbed would reduce but not necessarily eliminate incentives to preempt but would increase risks of accidental attack.
7. A capability to confirm the occurrence and identify the perpetrator of an ASAT attack and to retaliate in proportion, but not necessarily in kind, might deter ASAT attacks. A capability to retaliate in kind—i.e., against the attacker’s satellites—could contribute to deterrence, if this capability were survivable, but if this capability were vulnerable to ASAT attack, it could undermine deterrence by posing an opponent an incentive to attack preemptively. However, a capability to retaliate in kind would be inadequate to deter an ASAT attack by an adversary nation which values destruction of U.S. satellites more highly than survival of its own.
8. Strict arms control measures could not be expected to eliminate the inherent ASAT capabilities of weapons such as ICBMs nor provide complete confidence that no ASAT weapons have been developed and deployed covertly. In an arms control regime which bans ASAT weapons, use of passive countermeasures would be required to reduce the residual risk posed by weapons such as ICBMs. However, prohibiting the testing of ASAT capabilities of weapons would preclude the attainment of confidence that certain types of advanced, nonnuclear ASAT weapons would perform reliably if used and would therefore also reduce incentives to develop such weapons or to attempt to deploy them covertly. A ban on testing would also render more difficult, costly, and risky any attempt to attain confidence, by covert testing, that other types of advanced, nonnuclear ASAT weapons (e.g., ground-based lasers) would perform reliably if used and would therefore also reduce incentives to develop such weapons or to attempt to deploy them covertly.

Prohibiting the basing in space of weapons with ASAT capabilities, to the extent that compliance with such a ban could be verified,

would forestall the creation of strong incentives to attack such weapons preemptively when a similar attack is feared. Even in the absence of such strict restraints, if ASAT weapons are based in space, an agreement banning unauthorized close approach to foreign

spacecraft could reduce the ambiguity of such provocative acts and thereby reduce the risk of ASAT attack resulting from misunderstanding, while providing a legal basis for anticipatory self-defense against ASAT weapons of short effective range.

Chapter 5

ASAT Arms Control: History

Contents

	<i>Page</i>
Introduction	91
Constraints Imposed by Treaties and Agreements in Force	91
Charter of the United Nations	92
Limited Test Ban Treaty	92
The 1967 Outer Space Treaty	92
Strategic Arms Limitation Talks (SALT I & II)	93
Anti-Ballistic Missile (ABM) Treaty	94
International Political Barriers to ASAT Development	94
ASAT Negotiations—Past and Present	95
Background	95
1978-79 Negotiations	96
Soviet Draft Treaties	96
Congressional Interest in ASAT Arms Control and Executive Response	99
Current Activities in ASAT Arms Control	101

ASAT Arms Control: History

INTRODUCTION

This chapter discusses the constraints on ASAT development imposed by the treaties and agreements currently in force. It also briefly examines the history of ASAT weapons development and deployment, and describes the previous attempt by the United States and the Soviet Union to conclude a treaty further restricting such weapons. The issue of ASAT weapons and ASAT arms control, a politically volatile topic, has stimulated considerable interest in the U.S. Congress over the last several years; this chapter also discusses the history of the major pieces of legislation in the 97th, 98th, and 99th Congresses (1981-85) which concerned ASAT negotiations and weapons development.

Chapter 4 examined how certain passive and active ASAT countermeasures might contribute to U.S. national security and provide protection for critical space assets. Building on the historical background presented in this chapter, chapter 6 will examine the contribution that ASAT arms control might make to these same goals, analyzing a number of potential ASAT arms control regimes and identifying those which might be appropriate for the United States to pursue. The interaction between technical countermeasures and arms control is examined in chapter 7.

CONSTRAINTS IMPOSED BY TREATIES AND AGREEMENTS IN FORCE

To evaluate future space arms control measures it is first necessary to understand the constraints that existing treaties and other international agreements place on military space activities. No single treaty fully specifies which space activities are allowed and which prohibited, and existing agreements do not apply uniformly to all countries. All nations are presumably bound by the provisions of the Charter of the United Nations,¹ customary international law, and the "general principles of law recognized by civilized nations."² States

party to the 1967 Outer Space Treaty³ and the Limited Test Ban Treaty⁴ accept additional restrictions on their space activities. The United States and the Soviet Union agreed bilaterally in the context of SALT I (the ABM Treaty⁵ and the Interim Agreement to limit offensive arms) not to disturb the function of satellites used to verify compliance with those treaties and to forgo the development of space weapons to counter ballistic missiles. The relevant provisions of these instruments are discussed below.

¹As a general rule, only states party to a treaty are bound by its terms. An exception to this rule appears in Article 2 (6) of the U.N. Charter which provides: "The Organization shall insure that states which are not members of the United Nations act in accordance the Principles (of the Charter) so far as may be necessary for the maintenance of international peace and security." Charter of the United Nations, *1970 Yearbook of the United Nations*, p. 1001. See also: Ian Brownlie, *Principles of Public International Law* (3d ed., 1979).

²Statute of the International Court of Justice, Art. 38, *1970 Yearbook of the United Nations*, p. 1013.

³"Treaty on Principles Governing the Activities of States in the Exploration and Use of Outer Space, Including the Moon and Other Celestial Bodies," 18 U.S.T. 2410; T.I.A.S. 6347.

⁴"Treaty Banning Nuclear Weapon Tests in the Atmosphere, in Outer Space and Under Water," 14 U.S.T. 1313, T.I.A.S. 5433.

⁵"Treaty Between the United States and the U.S.S.R. on the Limitation of Anti-Ballistic Missile Systems," Oct. 3, 1972, 23 U.S.T. 3435, T.I.A.S. 7503.

Charter of the United Nations⁶

Article 2(3) of the U.N. Charter directs nations to "settle their international disputes by peaceful means in such a manner that international peace and security, and justice, are not endangered." Article 2(4) requires that nations "refrain . . . from the threat or use of force . . . in any . . . manner inconsistent with the purposes of the United Nations." It could be argued that these statements and other general principles of customary international law in some ways inhibit the use of ASATs.⁷

It is important to note that the responsibilities imposed by Article 2 of the U.N. Charter are modified by Article 51, which states, "Nothing in the present charter shall impair the inherent right of individual or collective self-defense." Taken together, Articles 2 and 51 do indicate general international censure of the use of force, but do not limit specific weapon systems.

Limited Test Ban Treaty⁸

The Limited Test Ban Treaty of 1963 prohibits nuclear weapons tests "or any other nuclear explosion" in outer space, as well as in the atmosphere or under water. The treaty therefore prohibits the testing, in space, of exotic ASAT weapons that would derive their power from a nuclear explosion⁹—a consequence probably not anticipated by the treaty's drafters. The Limited Test Ban Treaty would not limit the development or testing, on Earth

or in space, of other nonnuclear components for such weapon systems. The power source could be tested underground on Earth,¹⁰ as are other nuclear weapons, and the nonnuclear components could be tested separately in space.

The 1967 Outer Space Treaty¹¹

Article III of the Outer Space Treaty states that space activities shall be carried out in accordance with international law "in the interest of maintaining international peace and security and promoting international co-operation and understanding." This Article expresses the sentiment of the drafters that space be used to benefit mankind and contribute to peace.

In contrast to the general language of Article III, Article IV of the Outer Space Treaty establishes a clear prohibition against placing "in orbit around Earth any objects carrying nuclear weapons or any other kinds of weapons of mass destruction."¹² Orbiting weapons using nuclear explosions for power would presumably be included. This provision does not limit ground-based ASATs or ASATs which use conventional explosives or other means to destroy a target. Neither does it ban nuclear-armed "pop up" ASAT interceptors that ascend directly to their targets without entering into orbit.¹³

¹⁰Subject to other treaty limitations—see previous note.

¹¹Supra, note 3.

¹²According to Ambassador Arthur Goldberg, chief U.S. negotiator of the Outer Space Treaty, weapons of mass destruction include "any type of weapon which could lead to the same type of catastrophe that a nuclear weapon could lead to" (Hearings Before the Senate Foreign Relations Committee on Executive D, 90th Cong., 1st sess., p. 23.) In 1948, the U.N. Commission for Conventional Armaments advised the Security Council that the term "weapon of mass destruction" would include, "atomic weapons, radio-active material weapons, lethal chemical and biological weapons, and any weapons developed in the future which have characteristics comparable in destructive effect to those of the atomic bomb or other weapons mentioned above." (Resolution adopted by the Commission for Conventional Armaments at its 13th meeting, Aug. 12, 1948. U.N. Security Council, S/C.3/32/Rev. 1, Aug. 18, 1948.)

¹³Testing of such weapons which involved detonating nuclear warheads in space would be banned by the Limited Test Ban Treaty.

⁶Supra, note 1.

⁷Terrestrial international law is explicitly extended to space by Article III of the 1967 Outer Space Treaty, which states that the exploration and use of outer space shall be conducted "in accordance with international law, including the Charter of the United Nations."

⁸Supra, note 4.

⁹An additional limitation on nuclear-pumped space weapons can be found in the "Threshold Test Ban Treaty" of 1974. Article 1 prohibits tests of nuclear weapons greater than 150 kilotons in yield, banning even underground testing of any nuclear-driven weapon requiring an explosion larger than that. The Threshold Test Ban Treaty was signed by the United States but has yet to be ratified. "Treaty Between the United States of America and the Union of Soviet Socialist Republics on the Limitation of Underground Nuclear Weapon Tests," reprinted in, *Arms Control and Disarmament Agreements*, U.S. Arms Control and Disarmament Agency (1982 ed.), p. 167.

Article IX of the Outer Space Treaty directs nations to "undertake appropriate international consultations" before proceeding with any activity that might cause "potentially harmful interference with the activities of other states in the peaceful exploration and use of outer space." It is possible to argue that states developing ASATs (weapons *intended* to cause "harmful interference") should do so only after "appropriate international consultations." Nonetheless, the vague wording of Article IX and the forced nature of such an interpretation reduce the Article's value as an arms control provision.¹⁴

Taken together, the provisions of the Outer Space Treaty afford satellites some measure of legal protection against attack. The precise nature of this protection is unclear since the treaty was not drafted for the specific purpose of limiting deliberate hostile activities. The treaty clearly does not limit the development, testing, or deployment of nonnuclear weapons capable of interfering with satellites of other nations; moreover, the U.N. Charter provision for self-defense might be taken to permit such interference in some cases.

Strategic Arms Limitation Talks (SALT I & II)¹⁵

The verification provisions of SALT I and II state that the parties shall use "national technical means" (NTM) of verification to

monitor adherence to the Agreements. NTM is understood, though not explicitly specified, to include certain reconnaissance satellite systems. The SALT Agreements further state that "Each Party undertakes not to interfere with the [NTM] of the other Party" as long as these assets are operated "in a manner consistent with generally recognized principles of international law." The SALT Agreements implicitly sanction the use of satellites for verification of treaty compliance and provide some measure of protection against peacetime attack on these assets. These Agreements do not, however, restrict the development, testing, or deployment of ASAT systems capable of attacking NTM. In addition, whatever legal protection these Agreements provide is limited to systems used to verify the SALT Agreements. Other space systems used for combat support during hostilities would not be protected under the SALT provisions.

Article IX of SALT II prohibits the development, testing, or deployment of "systems for placing into Earth orbit nuclear weapons or any other kind of weapons of mass destruction, including fractional orbital missiles." This provision was included to limit the development of Fractional Orbital Bombardment Systems (FOBS), in which missiles enter partial Earth orbit and fly the long way around the Earth rather than taking the much more direct trajectory of normal ICBMs. However, this provision could also be read as expanding the prohibition of Article IV of the Outer Space Treaty. Whereas Article IV prohibits only the act of orbiting nuclear weapons, Article IX of SALT II would seem to prohibit in addition the development, testing and deployment of systems (e.g., launchers) to accomplish the orbiting of these weapons. So interpreted, Article IX could create an additional legal barrier to the development of

¹⁴The "Accidental Measures" Agreement of 1971 requires the United States and the Soviet Union to "notify each other immediately in the event of . . . signs of interference with [missile warning systems] or with related communication facilities." However, this agreement places no limitations on the development or use of ASAT capabilities. "Agreement on Measures to Reduce the Risk of Outbreak of Nuclear War Between the United States of America and the Union of Soviet Socialist Republics," reprinted in U.S. Arms Control and Disarmament Agency, *Arms Control and Disarmament Agreements* (Washington, D.C.: U.S. Government Printing Office, 1982), p. 159.

¹⁵"Interim Agreement Between the United States of America and the Union of Soviet Socialist Republics on Certain Measures with Respect to the Limitation of Strategic Offensive Arms" (SALT I) reprinted in, *Arms Control and Disarmament Agreements*, U.S. Arms Control and Disarmament Agency (1982 ed.), p. 139; "Treaty Between the United States of America and the Union of Soviet Socialist Republics on the Limitation of Strategic Offensive Arms" (SALT II), reprinted in U.S. Arms Control and Disarmament Agency *Arms Control and Dis-*

armament Agreements (Washington, DC: U.S. Government Printing Office, 1982), p. 246.

The completed SALT II agreement was signed by President Carter and General Secretary Brezhnev on June 18, 1979. Although Senate consent to ratification has not been given, Presidents Carter and Reagan both declared that they would do nothing to jeopardize the treaty as long as the Soviet Union abided by it.

orbital, nuclear-pumped, directed-energy weapons.

Anti-Ballistic Missile (ABM) Treaty¹⁶

In the ABM Treaty, the United States and the Soviet Union agreed not to deploy anti-ballistic missiles except under the very limited conditions set forth in the treaty.¹⁷ Each party also undertook not to "develop, test, or deploy ABM systems or components which are sea-based, air-based, space-based, or mobile land-based."

The distinction between advanced ASAT and BMD technologies is not always clear. As noted by Secretary of Defense Weinberger in a report to Congress,¹⁸ directed-energy weap-

¹⁶"Treaty Between the United States of America and the Union of Soviet Socialist Republics on the Limitation of Anti-Ballistic Missile Systems," *supra*, note 5.

¹⁷Article III limits each side to two fixed, ground-based ABM deployment areas (later reduced to one), each of which has limitations on radar facilities and interceptors and launchers. Agreed Statement D provides that should ABM systems based on other physical principles than missile interceptors be developed in the future, these would be subject to discussion and agreement. Unless such systems were explicitly permitted by future agreement, they would continue to be banned.

¹⁸C. Weinberger, *Fiscal Year 1985 Annual Report to Congress* (Washington, DC: U.S. Government Printing Office, February 1984), p. 263.

ons "could perform a variety of missions, such as antisatellite or ballistic missile defense." For the purposes of the ABM Treaty, "an ABM system is a system to counter strategic ballistic missiles or their elements in flight trajectory." Therefore, ASAT weapons would be prohibited by the ABM Treaty if they were capable of countering strategic ballistic missiles.* Such systems are banned unless they are fixed, land-based and deployed at permitted sites. The testing of ASAT weapons of lesser capability would not be inhibited by the treaty. If an ASAT weapon became capable of intercepting missiles, it would fall within the terms of the ABM treaty. This capability test includes future systems having components "based on other physical principles" than those of the ABM system components (interceptors, launchers, and radars) described in Article II of the treaty. However, the ABM Treaty does not control highly capable ASAT systems lacking ABM capability, and it does not clearly indicate how such capability is to be inferred.

*The ABM Treaty is discussed in greater detail in OTA's report, *Ballistic Missile Defense Technologies*, OTA-ISC-281, app. A.

INTERNATIONAL POLITICAL BARRIERS TO ASAT DEVELOPMENT

Although there are few clear international legal barriers to ASAT *development*, the desire of the United States to remain in some way responsive to international opinion creates certain inhibitions to the unrestrained pursuit of weapons that are based or operate in space. In the United Nations and other international fora, the United States and, to a lesser extent the Soviet Union, have been criticized for their military activities in space. Some view the "militarization" or "weaponization" of space as breaking a *de facto* political taboo; others see it as a violation of customary international law. Some of our allies, responding to strong domestic political pres-

ures to limit the arms race, see U.S. and Soviet cooperation in controlling space weapons as one means to reduce international tension. It is important to note, therefore, that there may be a significant political or diplomatic cost to developing space weapons.

Opposition to "space weapons" derives, in part, from the belief that space is a unique environment which must be preserved for "peaceful" activities and should be responsive to international controls. The "uniqueness" of space is seen as deriving from the fact that some space activities, such as remote sensing and satellite communications are inherently

global in effect; i.e., they pass over the territory of other countries and may require international coordination, such as frequency allocation. These characteristics have resulted in the development of a number of successful international institutions such as the International Telecommunication Union (ITU), the International Telecommunication Satellite Organization (INTELSAT), and the International Maritime Satellite Organization (INMARSAT).

The fact that certain space activities have been the subject of international controls has fostered a belief among some that all space activities should somehow require international consent. In this view, an unrestrained arms race between the United States and the Soviet Union in space is seen as threatening the interests of nations not having strong space programs as well as being a threat to peace.

The United Nations, and in particular its Committee on the Peaceful Uses of Outer Space (COPUOS), has been responsible for five international treaties dealing with space. Each of these treaties emphasizes to some degree the necessity that the exploration and use of space be for "peaceful purposes." In addition, many world leaders (including every President of the United States since Eisenhower), scholars, and jurists have, since the beginning of the space age, emphasized the unique nature of space and its ability to contribute to peace and the common good.

Having been nurtured for over 25 years, the idea that space is a unique environment which should be used for peaceful purposes has come to be considered by some to be a principle of customary international law. As a result, the development of weapons which would operate in or through space has met with strong opposition in international fora.

The 1982 General Assembly Resolution on the "Prevention of an Arms Race in Outer Space" reflects this international concern.¹⁹ The Resolution reaffirms the belief of the General Assembly that "space [activities] should be for peaceful purposes and carried on for the benefit of all peoples," and notes "the important and growing contribution of satellites for . . . the verification of disarmament agreements and . . . their use to promote peace, stability and international cooperation." Pointing out the "threat posed by anti-satellite systems and their destabilizing effect for international peace and security," the Resolution urges all states "to contribute actively to the goal of preventing an arms race in outer space and to refrain from any action contrary to that aim." Finally, it requests the U.N. Committee on Disarmament to consider "the question of negotiating effective and verifiable agreements aimed at preventing an arms race in space."

¹⁹U.N.G.A. Doc. A/36/192, Aug. 11, 1982.

ASAT NEGOTIATIONS—PAST AND PRESENT

Background

The first test of a weapon against a satellite was conducted by the United States in 1959 when a Bold Orion missile launched from a B-47 aircraft successfully passed within 20 miles of the U.S. Explorer VI satellite as it passed over Cape Canaveral. In 1963 and 1964, the U.S. Army operated a system of nuclear-armed direct-ascent ASAT interceptors on Kwajalein Atoll in the Pacific Ocean.

From 1964 until 1970, another such system was maintained on Johnston Island by the Air Force; this system was formally decommissioned in 1975.²⁰

²⁰Marcia Smith, "Star Wars: Antisatellites and Space-Based BMD" (Washington, DC: Library of Congress, Congressional Research Service, Issue Brief IB81123, Nov. 26, 1984); Paul Stares, "Deja Vu: The ASAT Debate in Historical Context," *Arms Control Today*, December 1983, p. 2.

The Soviet Union initiated a series of ASAT tests in 1968 which continued through 1971.²¹ Although the United States suspected that the Soviets were developing an "inspect and destroy" capability, this system was not seen as posing so significant a threat to U.S. assets that a response was necessary. However, when the Soviets conducted another series of ASAT tests between 1976 and 1978, U.S. officials began to express concern.

The Carter Administration adopted a "two-track" policy. In March 1977, President Carter announced that he had suggested to the Soviets that "we forgo the opportunity to arm satellite bodies and also to forgo the opportunity to destroy observation satellites."²² Also in that month, the Department of Defense announced that U.S. military space programs were being accelerated.²³

1978-79 Negotiations

The Soviets responded positively to Carter's proposal for ASAT negotiations and in March 1978, agreement was reached on an exploratory meeting. Three rounds of the ASAT limitation talks were held: June 8-16, 1978, in Helsinki; January 23-February 16, 1979, in Bern; and April 23-June 15, 1979, in Vienna. The third round of talks ended when the two sides felt they had gone as far as they could without further consultation and study in their respective countries.²⁴ According to Ambassador Robert W. Buchheim, head of the U.S. delegation for most of the 1978-79 ASAT talks, the two delegations agreed that when either decided that it was ready to resume active negotiations, the other party would be so notified through diplomatic channels.²⁵ Al-

though neither side formally withdrew from the negotiations, after the Soviet invasion of Afghanistan, the U.S. refusal to ratify the SALT II Treaty, and a general deterioration of U.S.-Soviet relations, discussions never resumed.

The 1978-79 talks did not result in an ASAT arms control agreement; however, they did clarify some of the concerns of the two parties. The talks focused on two main topics: limits on ASAT use, and limits on the development of ASAT capabilities.²⁶

During the 1978-79 negotiations, as now, the different status of the U.S. and Soviet ASAT programs was a substantial impediment to progress. The Soviet ASAT system was considered by the United States to be "operational," whereas the potentially more capable American system had yet to be tested. A limited moratorium or treaty would have given the United States time to conduct ground-based research and development while inhibiting Soviet ASAT weapons tests in space. An indefinite test ban, on the other hand, might have locked the United States into a position of ASAT inferiority.

Soviet Draft Treaties

In 1981 and again in 1983, the Soviets submitted draft space weapon treaties to the United Nations.²⁷ U.S. experts disagree as to why the Soviets have continued to advocate space weapon arms control. One theory holds that the Soviet interest is not in arms control, but rather in propaganda. Since the Reagan Administration was not actively seeking limitations on space weapons, the Soviets could portray the United States as being responsible for the escalation of the arms race and the

²¹*Soviet Space Programs: 1976-80*, Committee Print, Senate Committee on Commerce Science and Transportation, 97th Cong., 2d sess., December 1982, p. 184.

²²*The Washington Post*, Mar. 10, 1977, p. A4.

²³*Ibid.*

²⁴Lynn F. Rusten, "Soviet Policy on Antisatellite (ASAT) Arms Control" (Washington, DC: Library of Congress, Congressional Research Service, 84-670-S, June 22, 1984), p. 1.

²⁵"Arms Control and the Militarization of Space," Hearings Before the Subcommittee on Arms Control, Oceans, International Operations and Environment of the Committee on Foreign Relations on S.J. Res. 129, U.S. Senate, 97th Cong., 2d sess., Sept. 20, 1982, pp. 54-55.

²⁶For a more detailed discussion of the 1978-79 talks, see: Walter Slocumbe, "Approaches to an ASAT Treaty," *Space Weapons—The Arms Control Dilemma*, Bhupendra Jasani (ed.) (London: Taylor and Francis, 1984), p. 149; and Lynn F. Rusten, *op. cit.*

²⁷"Draft Treaty on the Prohibition of the Stationing of Weapons of Any Kind in Outer Space," U.N. General Assembly, Doc. A/36/192, August 1981; "Treaty on the Prohibition of the Use of Force in Outer Space and From Space Against the Earth," U.N. Doc. A/38/194, Aug. 26, 1983.

“militarization” of space. Another hypothesis is that the Soviets have a genuine interest in limiting ASAT technology because this is an area where the United States would be able to excel. Since the Soviets have clearly stated their opposition to the Reagan Administration’s plans to develop space-based BMD technologies, their interest in arms control in space—especially after March 1983—could be intended to inhibit the progress of this program.

The United States refused to participate in multilateral negotiation with the Soviets on either the 1981 or 1983 draft treaties. Whatever the true reason or combination of reasons for Soviet interest in ASAT arms control, the Soviets have used this issue—and the U.S. refusal to negotiate—effectively in their political propaganda. The Soviet position has been, until recently, that their space program has been purely peaceful in nature. Since 1958, according to Soviet Foreign Minister Gromyko, the Soviet Union “invariably stated and continues to state that space should be a sphere of exclusively peaceful cooperation.”²⁸

From an American point of view, the Soviet propaganda seems absurd since the Soviet Union has an “operational” ASAT and a very active military space program. From the point of view of many nonaligned governments, as well as important segments of the populations of our allies, the fact that the Soviet Union was as responsible for the “militarization of space” as the United States, or more so, did not lessen the culpability of the United States for refusing to negotiate. As a result, the Soviet propaganda on the “militarization” of space was initially successful in enhancing the international image of the Soviets while fostering criticism of the United States. More recently, the inability of the United States and the Soviet Union, in the summer of 1984, to come to an agreement regarding ASAT weapon and other arms control negotiations (discussed in detail

below) served to shift some of the burden of the “militarization” issue back to the Soviets.

Since their introduction at the United Nations, a good deal of attention has been given to the language of the two Soviet draft treaties. It is useful to examine these drafts since they provide valuable insights into how the Soviets have been thinking about arms control in space.

1981 Soviet Draft Treaty

The provisions of the 1981 and 1983 Soviet draft treaties reflect the major issues raised in the 1978-79 negotiations. Articles I and III, the operative provisions of the 1981 Soviet draft treaty, state:

- I. The member states undertake not to put into orbit . . . objects with weapons of any kind, . . . and not to deploy such weapons in outer space in any other way, including also on piloted space vessels of multiple use . . .
- III. Each member shall . . . not destroy, damage, or disturb the normal functioning and not to alter the flight trajectory of space vehicles of other member states where the latter have . . . been put into orbit in strict accordance with . . . Article I.

Because it prohibited only weapons stationed in orbit, the 1981 draft would not have restricted the testing, development, and deployment of ground-based or air-launched ASATs. Accordingly, the United States and the Soviet Union could have kept their current ASAT systems and also pursued future technologies such as ground-based or air-borne directed-energy weapons. The 1981 draft treaty would, however, have prohibited the development of space-based BMD systems.

According to Article III of the 1981 draft, parties would agree not to “destroy, damage, or disturb the normal functioning and not to alter the flight trajectory of space vehicles.” Presumably, signatories to such a treaty could agree as to the meaning of the words “destroy,” “damage,” and “alter the flight trajectory.” It is less clear that a quick consensus

²⁸Ibid. However, on May 29, 1985, in an interview by a West German reporter in Geneva, Col. Gen. Nikolai Chervov, a senior department head on the Soviet General Staff, claimed that the U.S.S.R. had successfully developed a direct-ascent satellite interceptor similar to that tested by the United States in the early 1960s and operational until the mid-1970s.

could be reached on what would be inhibited under the injunction against "disturbing the normal functioning." Would this prohibit interference with ground stations or the use of electronic countermeasures such as jamming or spoofing? Had the treaty been negotiated, these issues would have certainly been the subject of great attention and possible compromise.

Article II of the 1981 proposed treaty states that space vehicles shall be used in "strict accordance with international law." This language seems to reflect the often stated Soviet belief that certain space activities—e.g., the operation of direct-broadcast satellites—are a violation of national sovereignty. However, under the terms of Article III, the only satellites that would be denied the treaty's protection would be objects carrying "weapons of any kind."

1983 Soviet Draft Treaty

In August 1983, when then Soviet Chairman Andropov met with several U.S. Senators he made the following statement:

. . . (T)he Soviet Union considers it necessary to come to an agreement on a complete ban of tests and of deployment of any space-based weapons for striking targets on Earth, in the air and in space.

Furthermore, we are ready, in the most radical way, to resolve the issue of anti-satellite weapons—to agree to eliminate anti-satellite systems already in existence and to ban creation of new ones.

At the forthcoming session of the General Assembly of the United Nations, we will introduce proposals developed in detail on all these issues.²⁹

As indicated by Chairman Andropov, on August 22, 1983, Soviet Foreign Minister Gromyko submitted a new draft treaty to the U.N. General Assembly.³⁰ The new draft was more comprehensive than the 1981 draft, and

²⁹"Dangerous Stalemate: Superpower Relations in Autumn 1983, A Report of a Delegation of Eight Senators to the Soviet Union," Senate Doc. 98-16, Sept. 22, 1983, p. 28.

³⁰"Treaty on the Prohibition of the Use of Force in Outer Space and From Space Against the Earth," U.N. Doc. A/38/194, Aug. 22, 1983.

in particular went beyond it in calling for a ban on all testing of ASAT systems and the elimination of all existing ASAT systems (see appendix A). However, it also repeats many of the themes of the 1981 draft and of the 1978-79 negotiations.

Article 1 prohibits the "use or threat of force in outer space and the atmosphere and on the Earth through the utilization of . . . space objects" and the "use or threat of force against space objects." The "use or threat of force" language echoes the language of Article 2 of the U.N. Charter. Since by the terms of Article III of the Outer Space Treaty, the U.N. Charter already applies to space, it is unclear what this provision would add to existing international law. Article I does make it clear that: 1) space objects are not to be used to threaten objects in "outer space and the atmosphere and on the Earth"; and 2) space objects themselves are not to be threatened. This article would prohibit threats from space-based assets—e.g., ASAT or BMD weapons—and threats to space-based assets, whether from ground-, air-, sea-, or space-based systems.

Article 2 has five sections. Section 1 prohibits testing and deploying space-based weapons; this goes well beyond the simple "no-use" provision of the 1981 draft, which is repeated in section 2. Section 3 repeats the prohibition of the 1981 draft against destroying, damaging, disturbing the normal function or changing the flight trajectory of space objects of other states.

Under section 4 of Article 2, parties agree not to "test or create new anti-satellite systems and to destroy any anti-satellite systems that they may already have." There is no attempt in the treaty to define what constitutes an "anti-satellite system." Presumably, it would include both the proposed U.S. and current Soviet orbital interceptors. It is unclear how systems, such as the Soviet GALOSH ABM, which might have some ASAT capability, would be dealt with under the draft treaty.

Section 5 of Article 2 prohibits the "test or use of manned spacecraft for military, includ-

ing antisatellite, purposes." Because of the limitations that this would place on the U.S. Space Shuttle, it is unlikely that the United States would agree to such a provision. In any case, since the SALT agreements allow verification by "national technical means" (NTM) and the Shuttle is the launch vehicle for Government payloads—including satellites used for NTM—this provision would seem to conflict with current Soviet and U.S. agreements.

Congressional Interest in ASAT Arms Control and Executive Response

Following the introduction of the two Soviet draft treaties, the Reagan Administration expressed no interest in negotiating these or any other limitations on ASAT weapons. As time passed, Members of Congress in both Houses began to apply pressure on the Administration to halt ASAT testing and to begin negotiations with the Soviets. This pressure was applied most effectively in amendments to the Department of Defense authorization and appropriations bills.

The following resolutions concerning space weapons were introduced in the 97th Congress (1981-82).³¹ None of them were reported out of committee or passed by either House:

- **Senate Resolution 129** (introduced by Pressler, R-S.Dak.) calling for resumption of ASAT limitations talks.
- **Senate Executive Resolution 7** (Pressler), calling for negotiation of a protocol to the 1967 Outer Space Treaty that would provide a complete and verifiable ban on ASAT development, testing, deployment, and use.
- **Senate Resolution 488** (Matsunaga, D-Hawaii), calling for talks with the Soviet Union concerning the possibility of establishing a weapons-free international space station.

- **House Joint Resolution 607** (Moakley, D-Mass. and 29 cosponsors), calling for the immediate negotiations for a ban on space weapons of any kind.

The number of bills and resolutions on space weapons introduced in the 98th Congress (1983-84) rose dramatically, with all but one dying in committee.³² The exception was S.J.Res. 129 (Pressler and 28 others), which was reported favorably out of the Senate Foreign Relations Committee and significantly modified before being introduced, and later withdrawn, as an amendment to the fiscal year 1985 DOD authorization bill. A resolution suggesting that international cooperation in space be pursued as an alternative to the arms race was passed by Congress and signed into law (S.J.Res. 236; Public Law 98-562), but only after most of the language concerning the arms race had been deleted. The most important actions of the 98th Congress resulted from amendments to the DOD authorization and appropriation bills.

The Fiscal Year 1984 DOD Authorization Bill

While the House of Representatives was debating the fiscal year 1984 DOD authorization bill (H.R. 2969), two amendments concerning ASAT weapons were introduced. The first, introduced by Representative George Brown (D-Calif.), would have denied procurement funding for the ASAT weapon; the second, introduced by Representative Seiberling (D-Ohio), would have prohibited the flight testing of the ASAT until authorized by Congress. Both amendments were defeated.

In the Senate, an amendment introduced by Senator Tsongas and unanimously passed prohibited the expenditure of funds for tests of

³²Legislation not reported from committee in either House or Senate:

Legislation Opposed to Space Weapons: H.J. Res. 87 (Kastenmeier, D-Wis.); H.J. Res. 120 (Moakley, D-Mass. and 130 others); S.J.Res. 28 (Tsongas, D-Mass. and 8 others); H.J.Res. 523 (Dicks, D-Wash. and 58 others) and 524 (Dicks and 55 others); H.J.Res. 531 (Brown, D-Calif. and 96 others).

Legislation in Favor of Space Weapons: S.Res. 100 (Wallop, R-Wyo. and 14 others); S. 2021 (Armstrong, R-Colo.); H.Res. 215 (Whitehurst, R-Va.); H.Res. 259 (Bennett, D-Fla. and 17 others); H.R. 3073 (Kramer, R-Colo. and 13 others)

Source: Smith, op. cit.; and Library of Congress SCORPIO database.

³¹For a more detailed history of congressional activity during the 97th and 98th Congresses, see Marcia S. Smith, "Star Wars: Antisatellites and Space-Based BMD" (Washington, DC: Library of Congress, Congressional Research Service, Issue Brief IB81123, Nov. 26, 1984).

explosive or inert ASAT weapons (i.e., exempting directed-energy weapons) against objects in space, unless the President determined and certified to Congress that: 1) the United States was endeavoring in good faith to negotiate a treaty with the Soviet Union for a mutual, verifiable, and comprehensive ban on ASATs; and 2) that pending such an agreement, such tests were necessary for the national security.

The Fiscal Year 1984 DOD Appropriation Bill

Following a proposal by Representative McHugh, the House Appropriations Committee deleted the fiscal year 1984 ASAT procurement funds pending a report from the President on his policies regarding arms control in space. The Senate Appropriations Committee took no similar action, but during floor debate, the Senate adopted an amendment introduced by Senator Tsongas requiring the President to submit a report on the national security implications of the Strategic Defense Initiative.

In the course of the House and Senate conference on the appropriations bill, the conferees agree to provide \$19.4 million for advance procurement for the ASAT program as proposed by the Senate, instead of no funds as proposed by the House. However, the conferees direct that these funds not be obligated or expended until 45 days following submission to Congress of a comprehensive report on U.S. policy on arms control. The appropriations bill, as amended, was passed by both Houses and signed into law (Public Law 98-212).

President Reagan's March 1984 Report on ASAT Arms Control

On March 31, 1984, the Reagan Administration issued its "Report to the Congress on U.S. Policy on ASAT Arms Control," thus satisfying the requirements of the fiscal year 1984 DOD appropriation bill. The report stated that the Administration was "studying a range of possible options for space arms control with a view to possible negotiations with the Soviets." However, it concluded that "no arrangements or agreements beyond those already governing military activities in outer

space have been found to date that are judged to be in the overall interest of the United States and its Allies." The report stated that the search for effective ASAT arms control was impeded by the "difficulties of verification, diverse sources of threats to U.S. and Allied satellites and threats posed by Soviet targeting and reconnaissance satellites which undermine conventional and nuclear deterrence," and it emphasized the necessity for the development of a U.S. ASAT weapon.

The Fiscal Year 1985 DOD Authorization Bill

When considering the fiscal year 1985 DOD authorization bill, the House approved an amendment introduced by Representative George Brown. The amendment prohibited the use of funds for ASAT testing against objects in space until the President certified to Congress that the Soviet Union had conducted an ASAT test after the enactment of the bill. The House later accepted an amendment (offered by Representative Gore) to the Brown amendment which limited testing until the President certified that either the Soviet Union *or another* foreign power had conducted such a test.

The Senate Armed Services Committee recommended that the fiscal year 1984 authorization language restricting ASAT tests be relaxed to permit ASAT tests against objects in space provided only that the President certified such tests to be essential for pursuing arms control arrangements. During floor debate, the Senate adopted a compromise amendment offered by Senators Warner and Tsongas that prohibited spending funds for testing ASAT weapons against objects in space until the President certified to Congress:

- that the United States was endeavoring in good faith to negotiate a mutual and verifiable agreement with the strictest possible limitations on ASATs consistent with the national security interests of the United States;
- that pending agreement on such a ban, tests against objects in space were necessary to avert clear and irrevocable harm to the national security;

- that such testing will not constitute an irreversible step which will gravely impair prospects for negotiations; and
- that testing is fully consistent with U.S. obligations under the ABM Treaty.

With some minor changes, the Warner-Tsongas amendment was adopted in the House and Senate conference report.

The Fiscal Year 1985 DOD Appropriation Bill

Fiscal year 1985 appropriations for the Department of Defense were included in the Continuing Appropriation Bill (Public Law 98-473). The appropriation bill, as enacted, reflects the compromise reached on the DOD authorization bill. The only differences are that no tests against an object in space are permitted before March 1, 1985, or 15 days after the President submits the required certifications, whichever is later, and no more than three tests against objects in space are permitted in fiscal year 1985.

Current Activities in ASAT Arms Control

On June 29, 1984, about 3 months after the President's March 31 report had been released, the official Soviet news agency Tass announced that the Soviet Government had offered to start talks "to prevent the militarization of outer space."³³ "To provide favorable conditions for the achievement of agreement," Tass reported that the Soviet Union was prepared, "to impose on a reciprocal basis a moratorium on the tests and deployment of these weapons, starting with the date of the opening of the talks."³⁴ The Soviets suggested that such meetings should take place in Vienna in September 1984.

In response, the Reagan Administration stated that it was now ready to "discuss and seek agreement on feasible negotiating approaches which could lead to verifiable and effective limitations on antisatellite weapons."³⁵

The Administration also announced that in addition to discussing space weapons it intended "to discuss and define mutually agreeable arrangements under which negotiations on the reduction of strategic and intermediate-range nuclear weapons can be resumed."³⁶ However, the Administration stressed that there were "no preconditions on the U.S. willingness" to discuss the entire range of arms control issues.

The Soviets objected to discussing strategic and intermediate-range missiles at the same time as space weapons. The Soviets proposed that the parties publish a joint public announcement that would define the purposes of the talks as being limited to the subject of space weapons and would endorse the concept of a moratorium on testing. The United States responded that it was prepared to talk about space weapons but that it was not prepared to agree to a moratorium.³⁷ The Soviets rejected the U.S. position and declared that it made the talks "impossible."³⁸ Although the U.S. Administration sent new messages modifying and "clarifying" its initial stand, these too were spurned by the Kremlin.

In the weeks following the initial exchanges there was little communication between the parties. The real argument seemed to be over which side would take the blame for refusing to negotiate. No meeting was held in September although both Washington and Moscow continued to express interest in arms control in space.

Six months later, on January 8, 1985, U.S. Secretary of State George Schultz and Soviet Foreign Minister Andrei Gromyko concluded 2 days of talks concerning the structure of future arms control negotiations. They jointly released a communique indicating that planning would commence on "the forthcoming U.S.-Soviet negotiations on nuclear and space arms" on "a complex of questions concerning space and nuclear arms, both strategic and in-

³³"Soviet and U.S. Statements on Space Weapons Negotiations," *New York Times*, June 30, 1984, p. 4.

³⁴Ibid.

³⁵Ibid.

³⁶Ibid.

³⁷"Soviets Say U.S. Makes Talks on Space 'Impossible'," *The Washington Post*, July 28, 1984, p. A1.

³⁸Ibid.

intermediate range . . . The objective of the negotiations will be to work out effective agreements aimed at preventing an arms race in space" along with constraining terrestrial arms and increasing strategic stability.³⁹

Negotiations between the United States and the Soviet Union began in Geneva in March 1985. Throughout these negotiations, the Soviet delegation has insisted that the termination of President Reagan's Strategic Defense Initiative is a necessary first step to any reduction in offensive arms. U.S. negotiators have, for their part, argued that advanced ballistic missile defense systems could provide a means by which both parties could safely negotiate deep reductions in their nuclear arsenals. As a result of this deadlock, both sides appear to remain far from agreement on anti-satellite limitations.

On August 20, 1985, pursuant to the Fiscal Year 1985 DOD Authorization Act (discussed above), the President certified that the four requirements set out by Congress had

been fulfilled.⁴⁰ President Reagan's decision to test the U.S. MV ASAT weapon against an object in space has reinvigorated congressional debate on the ASAT issue.

The Soviet response to the U.S. ASAT program has fluctuated. In 1983, President Andropov implied that the U.S.S.R. would rescind its self-imposed moratorium on ASAT testing if the United States *began* its ASAT test program. Then, in May 1985, in an interview with a West German reporter, Col. Gen. Nikolai Chervov, a senior department head of the Soviet General Staff, stated that the U.S.S.R. would rescind its moratorium if the United States *completed* testing the F-15 launched ASAT weapon. Most recently, the official Soviet news agency Tass, said that if the United States "holds tests of antisatellite weapons against a target in outer space," the Soviet Union "will consider itself free of its unilateral commitment not to place antisatellite weapons in space."⁴¹

³⁹Statement text from *The Washington Post*, Jan. 9, 1985, p. A14.

⁴⁰Presidential Determination No. 85-19 of August 20, 1985, *Federal Register*, vol. 50, No. 165, Aug. 26, 1985, pp. 34441-34443.

⁴¹*Washington Post*, Sept. 5, 1985, p. A-17.

Chapter 6

ASAT Arms Control: Options

Contents

	<i>Page</i>
Introduction	105
Provisions Restricting ASAT Testing	106
Monitoring Compliance With a Test Ban	106
Utility of an ASAT Test Ban	109
Provisions Restricting ASAT Possession or Deployment	112
Monitoring Compliance With Limitations on Possession and Deployment	112
Utility of Limitations on Possession and Deployment	113
Provisions Restricting ASAT Use	114
Monitoring Compliance With a "No Use" Agreement	115
Utility of a "No Use" Agreement	115
Provisions Restricting Spacecraft Operation and Orbits	116
Monitoring Compliance With a "Rules of the Road" Agreement	118
Utility of a "Rules of the Road" Agreement	118
BMD and ASAT Treaties of Limited Duration	119
Compliance Monitoring, Verification, and Recourse	120
Monitoring	120
Interpretation	121
Assessment	121
Recourse	122

Table

<i>Table No.</i>	<i>Page</i>
6-1. Sensor Technology for Compliance Monitoring	110

ASAT Arms Control: Options

INTRODUCTION

This chapter explores how various ASAT arms control provisions might affect the long-term national security interests of the United States. The interaction between these arms control provisions and the unilateral satellite survivability measures that the United States might pursue is discussed in greater detail in chapter 7. Four types of arms control are presented below: restrictions on ASAT testing, possession, use, and "rules of the road" for space. Each of these provisions is described and an assessment is given of its ability to protect U.S. space assets and contribute to other long-term U.S. goals. Potential conflicts between ASAT arms control and the development of military capabilities (e.g., the U.S. MV ASAT program and the Strategic Defense Initiative) are also examined.

The development of anti-satellite weapons poses a significant threat to the military satellites of both the United States and the Soviet Union. These military satellites, in turn, provide information and services which can be threatening to either side. Here lies the inherent difficulty in arriving at acceptable ASAT arms control agreements—given the choice, the United States would like to protect its own satellites while eliminating any military threat posed by Soviet satellites.¹ Since such a one-sided advantage is not possible, it is reasonable to examine whether there are mutual restraints that would contribute to national security and protect U.S. satellites, yet allow an adequate response to the threat posed by Soviet satellites.

The debate over ASAT arms control contains many familiar themes: To what extent

can the the United States monitor Soviet compliance? Do the Soviets intend to cheat, and if so, can they? What recourse would the United States have if faced with either clear or ambiguous Soviet violations? Is the United States better off pursuing arms control, technological superiority, or some combination of both? What will be the response of our allies to new development programs or arms control proposals? These issues are discussed below, both in the context of specific arms control provisions and in a more general discussion of monitoring treaty compliance.

Most of the provisions discussed in this chapter would require the United States and the Soviet Union to enter into a bilateral agreement to limit ASAT weapons development. As a result of the technologies involved, their theater of operation, and the closed nature of Soviet society, it is unlikely that the United States could monitor Soviet compliance with complete certainty. The United States can know only part of what the Soviet Union does and little or nothing about what it intends; therefore, any arms control agreement involves some degree of risk. **For the purposes of this discussion, the value or danger of a particular arms control provision is measured by its likely impact on U.S. national security after allowance is made for possible covert Soviet violations. In other words, given the risks of entering into an agreement with the Soviets, are we better off with or without a particular provision?**²

This chapter focuses primarily on bilateral treaties of unlimited duration. Other arrangements for ASAT constraints, such as multi-

¹Not all Soviet military satellites threaten the United States. Presumably, the United States would like the Soviet Union to retain some reconnaissance and early warning satellites since these satellites contribute to stability by allowing verification of arms control agreements and by assuring the Soviets that they are not under nuclear attack.

²It is important to note that "risk," as it is used here, does not imply merely the probability that the Soviets can or would violate a particular provision of an ASAT agreement. Rather, risk signifies both the probability that the Soviets would violate the agreement and the threat to U.S. national security that would likely result from such a Soviet violation.

lateral agreements, joint declarations, executive agreements or even unilateral declarations, might also be in the national interest. However, this report is limited exclusively to bilateral agreements for the sake of simplic-

ity and primarily to formal treaties of unlimited duration because they are the hardest to obtain and have the most lasting effect on national policy and programs.

PROVISIONS RESTRICTING ASAT TESTING

An agreement that established limits on testing could be a useful means by which to prevent the development of reliable, dedicated ASAT systems. The effectiveness of test restrictions is assumed to derive from the naturally conservative nature of military planners. Many informed observers believe that, except when forced by necessity, Soviet military planners would be reluctant to rely on systems that have not been tested near their full capabilities, particularly in situations where the stakes are high, second chances may not come, and the penalties for failure could be severe.

A test ban would prevent the testing which would increase confidence in new ASAT weapons or, at minimum, would force testing to be done covertly, under less than optimal conditions. In either case, the result would be to erode the confidence that an ASAT system would work as planned, when needed.

There are several ways to frame a test ban. The most comprehensive would be a ban on all "testing in an ASAT mode." For the purposes of this discussion, "testing in the ASAT mode" would include tests of ground-, sea-, air-, or space-based systems against targets in space or against points in space. Testing of ASAT systems or components on the ground would not be prohibited. Such an approach would avoid both the necessity of defining an ASAT weapon and of restricting systems that, although not designed as ASATs, might have some inherent ASAT capability. For example, it is possible that the Soviet GALOSH ABM system might have some ASAT capability. An agreement that banned all "testing in an ASAT mode" would not require the United States and the Soviet Union to agree whether

GALOSH was an ASAT or if it *could function* as an ASAT, but would simply ban the testing of this system as an ASAT.

More limited "no-test" agreements could also be used to inhibit the development of specific types of ASATs or to place restrictions on certain types of testing. Such a treaty might be used to ban the testing of only ASAT weapons that would be based in space. Alternatively, it might be used to ban the testing of specific space-based ASAT weapons (e.g., directed-energy weapons or space mines) thought to be particularly destabilizing. Such a ban might also limit ASAT testing to low altitudes to protect critical early warning and communication satellites that are in higher orbits.

All of these examples of limited test bans could be further modified by agreed limitations on allowable numbers of tests. For example, the United States and the Soviet Union might agree to limit themselves to only 10 tests over the next 5 years, or to a set number (either constant or declining) of tests per year for the duration of the agreement.

Monitoring Compliance With a Test Ban

In past bilateral agreements between the United States and the Soviet Union, the Soviet Union has tended to take advantage of treaty ambiguities and to engaged in activities that—although sometimes difficult to characterize—bordered on treaty violation.³ It is prudent, therefore, to assume that should

³There is reason to believe that the Krasnoyarsk radar, when complete and ready for operation, will violate the ABM Treaty.

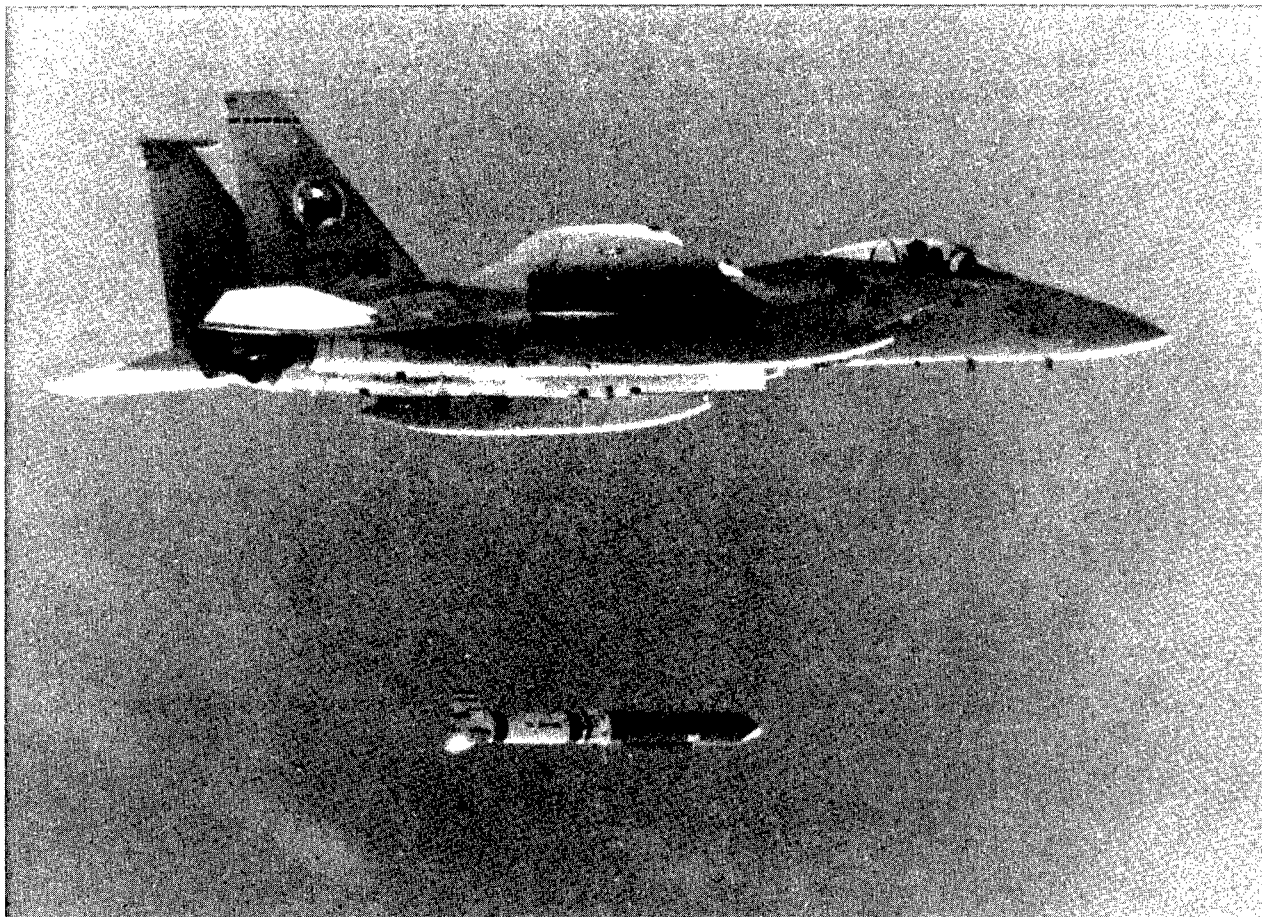

Photo credit: U.S. Air Force

F-15 launched, MV anti-satellite weapon currently under development in the United States.

an ASAT test ban be negotiated, the Soviets would comply only to the extent that the United States was able to verify its compliance. This being the case, it is important to examine some of the problems associated with monitoring the wide range of Soviet activities that might be related to ASAT weapon development.

Scope of Monitoring Task

One barrier to verifying compliance with a test ban is the enormous volume of space where illicit activities might be conducted. Verification of compliance with a SALT or START arms control agreement involves inspection of a number of areas in the Soviet Union or its immediate airspace. This area, al-

though large, is relatively well determined and is amenable to close inspection by space-based photographic reconnaissance satellites. The region where space activities must be monitored starts at altitudes of about 100 km and can range well past geosynchronous orbit at 36,000 km. In addition, advanced ground-based ASATs could be located anywhere in the Soviet Union and air-based ASATs might even operate from non-Soviet airfields.

Although the volume of space is indeed large, space-based ASAT activities must start on the ground. Relevant ground sites, including launch facilities, can be observed by an extensive array of U.S. monitoring facilities; launches of ICBMs and similar vehicles from Soviet territory can be detected. To some ex-

tent, the problems created by the large volume of space are offset by the fact that space is transparent and accessible to monitoring. Current weaknesses in ground-based surveillance systems can be mitigated by putting surveillance systems into space.

If the Soviets were to develop air-based, ground-based, or "pop-up" directed-energy weapons, these would require extensive testing. It is likely that some portion of this testing could be conducted out of the sight of (e.g., indoors or underground) U.S. monitoring assets. However, full development would probably require some in-space testing against targets. Possible targets could, in principle, be monitored to see if they are being illuminated by strong lasers, are giving off gases, are being unexpectedly accelerated, or are emitting unusual signals. Air- and ground-based systems might be detectable by national technical means. Nonnuclear, space-based systems would be quite large and might emit detectable amounts of hydrogen fluoride or other gases.

Problems of Discrimination

Verifying treaty compliance is complicated by the growing number and variety of Soviet space launches. Although the launch rate may decrease in the future as the Soviets develop longer lived satellites, space surveillance requires a body of experience with each additional type of satellite in order to classify its function and discriminate between unusual activity and routine behavior. The functional characteristics distinguishing ASAT weapons, such as space mines, from other satellites may not be readily observable. Some occurrences might have multiple interpretations. For example, a satellite fragmenting in orbit could be accidental, the test of a self-destruct mechanism (either to avoid capture or to prevent large components from falling back to Earth), or the test of a space mine.⁴ All national technical means have imperfect discrimination,

and the physical differences between permitted and prohibited satellites may be small.

Although the annual number of Soviet launches is large, the number of new satellites or satellites engaged in "unusual activities" is relatively small. Even if U.S. national technical means of verification could not *by direct observation* distinguish between space mines and normal satellites, other indicators, such as orbital parameters, proximity to other—particularly U.S.—satellites, and other sources of intelligence might supply the needed information. If in addition to a test ban the treaty also included some mechanism for resolving ambiguities—e.g., the Standing Consultative Committee established in SALT I—the problem might be further resolved.

Assuming that the difficulties associated with deliberate ASAT systems were resolved, it would still be necessary to reach some agreement concerning tests of advanced, ground-based, BMD systems. Should conventional ground-launched BMD systems be developed—similar to the system recently demonstrated in the U.S. Homing Overlay Experiment (HOE)—they may have some limited ASAT capability.

Covert Development

There are numerous ways for the Soviets to engage in covert ASAT development. It is possible that space mine or orbital interceptor tests could be masked as legitimate rendezvous operations or satellite repair missions. ASAT weapons might be directed against points in space or space debris, thereby obviating the need for recognizable target satellites. ASAT vehicles or their targets could be instrumented to store test data for broadcast over the Soviet Union or for deorbit in a reentry capsule, thereby preventing the United States from intercepting test information. Nuclear-armed ICBMs or ABM launchers such as the Soviet GALOSH might also be tested (though not detonated) in a manner which would be difficult to characterize. Relatively low-powered lasers capable of blinding satellite sensors are already available and

⁴One could, of course, ban all deliberate explosions in space. If such a ban were made part of a more general test ban, there would be less ambiguity to resolve.

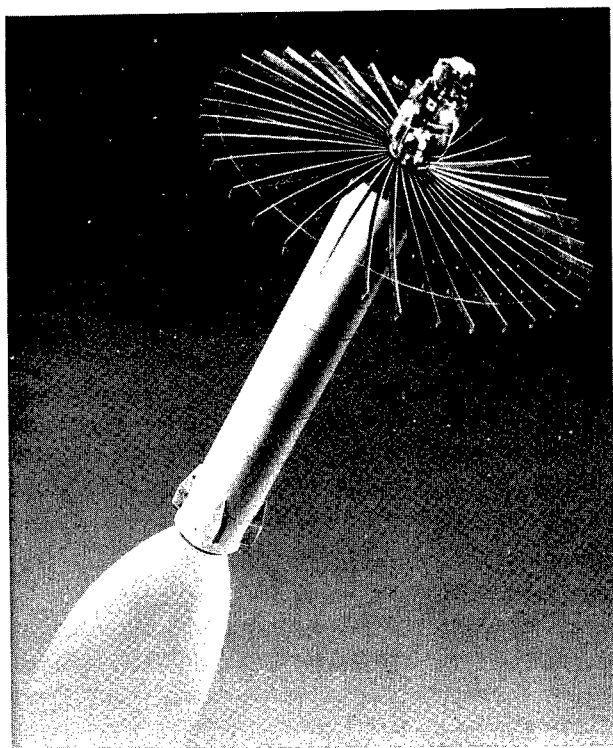

Photo credit: U.S. Department of Defense

Artist's conception of the nonnuclear ABM interceptor recently tested in the Homing Overlay Experiment (HOE). The current Soviet GALOSH nuclear ABM interceptor or future, nonnuclear systems based on HOE technology could complicate the process of monitoring an ASAT weapon test ban.

might be tested without being clearly identified as being ASATs.

It is, on the other hand, possible to exaggerate the threat posed by covert development. The United States is sufficiently familiar with the operational characteristics of the current generation of Soviet ASAT interceptors to make its covert testing unlikely. The development of a new system would require an extensive testing program, some portion of which we would almost certainly identify. New or unusual orbiting vehicles would be noticed, especially maneuvering ones. Monitoring equipment could be developed that would detect the laser illumination of Soviet satellites, and which could aid in monitoring Soviet directed-energy facilities. (See table 6-1, below). Soviet efforts to hide covert testing might serve to narrow down the regions where the United

States needs to concentrate its verification efforts. In any case, it is likely that an ASAT test limitation agreement would provide the means by which parties could inquire about suspicious activities.

Utility of an ASAT Test Ban

Considering both the limitations of U.S. monitoring capabilities and the possible ill-intentions of the Soviet Union, what then is the value of an ASAT test ban? To answer this question completely, one must examine the specific test bans being considered in combination with possible technical countermeasures (this is done in chapter 7). However, some preliminary generalizations can be helpful.

Some of the satellites that the United States relies on for critical information are now vulnerable and few in number. With respect to these specific systems, a small degree of Soviet cheating under a test ban agreement might have a significant effect on U.S. security. On the other hand, the United States has been quite successful at monitoring past Soviet space activities and the deployment of more capable monitoring assets—e.g., space-based surveillance systems—could substantially aid the process of treaty monitoring.

It is important to note that modest satellite survivability measures would reduce the risk posed by current ASAT weapons and could do much to reduce the risk posed by covert weapons development. In the absence of an agreement limiting ASAT weapon development, the United States must still monitor Soviet activities but modest survivability measures might not be effective. Without limitations, advanced ASATs would pose a greater risk to a larger number of satellites and failure to effectively monitor these advanced ASATs could create a significant danger to U.S. national security.

Comprehensive Test Ban

A ban which prohibited all testing "in the ASAT mode" would severely reduce the likelihood that the Soviet Union could successfully develop advanced, highly capable ASAT weap-

Table 6-1.—Sensor Technology for Compliance Monitoring

Prohibitible action	Observables	Sensors
ASAT attack:		Attack sensors:
KEW ^a impact	acceleration	accelerometers
Pulsed HEL ^b irradiation	acceleration	accelerometers
Continuous HEL irradiation	heating	thermistors
NPB ^c irradiation	ionization	ionization detectors
Keep-out zone penetration	position of thermal radiation source (ASAT)	space-based LWIR ^d thermal imager ^{e f}
Interception test	positions of thermal radiation sources (ASAT and target)	space-based LWIR thermal imager ^{e f}
NPB ASAT operation	thermal radiation from ASAT	space-based LWIR thermal imager ^{e f}
HEL ASAT operation	thermal radiation from ASAT	space-based LWIR thermal imager ^{e f}
Irradiation of target with NPB	gamma radiation from target	gamma-ray spectrometer ^g
Irradiation of target with pulsed HEL	thermal radiation from target	space-based LWIR thermal imager
Irradiation of target with pulsed HEL	reflected radiation from target	space-based multispectral imager
Irradiation of target with continuous HEL	position of thermal radiation source (target)	space-based LWIR thermal imager
Irradiation of target with continuous HEL	reflected radiation from target	space-based multispectral imager
Nuclear explosive aboard satellite	gamma radiation from fissile or fusable nuclei activated by cosmic radiation or by particle beams	gamma-ray spectrometer (and optional particle beam generator)

^aKinetic-energy weapon.

^bHigh-energy laser.

^cNeutral particle beam.

^dLong-wavelength infrared.

^eThe LWIR telescope on the Infrared Astronomical Satellite (IRAS) exemplifies demonstrated space-based thermal imager technology; this instrument is described in *Astrophysical Journal*, 278 (1, Pt. 2): L1-L85, Mar. 1, 1984 (Special Issue on the Infrared Astronomical Satellite).

^fRadar and passive radio direction-finding methods could also be useful for tracking, if hiding measures are not employed by the penetrating spacecraft. LWIR tracking is emphasized here because it is difficult to counter by such measures.

^gA target irradiated by a high-energy neutral particle beam will emit gamma rays, neutrons, and other observable particles, just as it will, at a slower rate, when bombarded by natural cosmic rays. These gamma rays could be detected by a gamma-ray spectrometer such as those which have been carried by Soviet Venusian and lunar landers and by U.S. NASA Ranger and Apollo spacecraft. (NASA report SP-387, pp. 3-20.)

ons. The categories of weapons eliminated might include space mines capable of “shadowing” valuable military assets in any orbit, or directed-energy weapons with kill radii of hundreds to thousands of kilometers. In the absence of an agreement limiting the development of these weapons, each side might seek continually more effective means to attack threatening satellites and to defend valuable assets. This could result in a potentially destabilizing arms race in space. The “instantaneous kill” ability of the most advanced ASATs would be destabilizing in a crisis, since each side would have the incentive to “shoot first” or else risk the loss of its space assets.

A comprehensive test ban would require both the United States and the Soviet Union to cease testing their current generation of ASAT weapons. The Soviet ASAT is already considered operational. Assuming the United States also had an operational ASAT when the agreement entered into force, each side’s ex-

isting system would pose some threat to the other side. Over time, a comprehensive test ban would gradually erode each side’s confidence in its respective weapons, thereby reducing the possibility of their use. If a test ban were combined with additional restrictions on possession or deployment, this might result in somewhat greater security.

A comprehensive test ban would be less effective at reducing the threat posed by weapon systems with “inherent” ASAT capability. ICBMs, SLBMs, and ABM interceptors with nuclear payloads are examples of systems with inherent ASAT capability. Although these systems lack the kind of guidance necessary to intercept a satellite with great precision, the long-range destructiveness of their nuclear payloads makes them potentially effective ASATs. However, some of the ASAT threat posed by nuclear weapons is offset by their very nature. The collateral physical, political, and military consequences of using nuclear

ICBMs or ABMs as ASATs could well deter their use in most conflicts short of a terrestrial nuclear war.

The Shuttle's recent success at retrieving and refurbishing satellites strongly suggests the ASAT potential of future maneuverable spacecraft. However, the range, effectiveness and reaction time of even advanced maneuverable systems would be substantially less than that of future dedicated ASATs. Although the development of maneuverable spacecraft would not be inhibited by most ASAT testing limitations, some limits could be placed on operating them in an ASAT mode.

The Soviet draft treaties and the 1983 unilateral Soviet moratorium on ASAT testing suggest that the Soviets would be willing to negotiate about a comprehensive ASAT test ban. To date, the U.S. response to Soviet suggestions has been to point out that since the Soviets have an "operational" ASAT and the U.S. testing program has just begun, a comprehensive test ban would prevent the United States from ever having a reliable interceptor ASAT and would increase the threat posed by a Soviet "breakout." Nonetheless, the United States has continued to express interest in ASAT negotiations and has not ruled out the possibility that it would agree to some kind of test limitations.

Limited Test Bans

Should a comprehensive test ban be considered undesirable or nonnegotiable, it might still be worthwhile to limit testing to the current generation of ASATs or to ASATs only capable of attacking satellites in low-Earth orbit. A ban which limited each side to testing its current ASAT would have three advantages: 1) a ban on testing new types of ASATs would reduce the likelihood that advanced ASATs, such as space mines or space-based directed-energy weapons, would be developed; 2) the threat to critical early warning and communication satellites would be diminished; and 3) the United States would retain the ability to negate Soviet low-orbiting, targeting, and data collection satellites judged to pose a threat to U.S. surface forces.

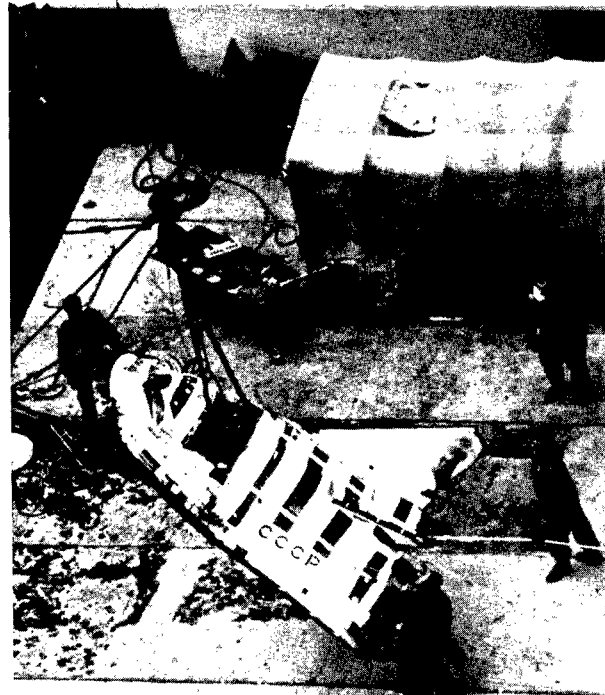

Photo credit: U.S. Department of Defense

Ocean recovery of what is believed to be an unmanned scale model of a new Soviet space plane. The development of maneuverable spacecraft would not be inhibited by most ASAT testing limitations, but some restrictions might be placed on operating such spacecraft "in an ASAT mode."

If a limited test ban could restrict each side to its current, low-orbit, ASAT capability, it would, in effect, create high-altitude "no attack zones."⁵ This might encourage adversaries to move some Earth monitoring space assets into those zones. The development of high-altitude data collection systems would re-

⁵If advanced directed-energy weapons with kill radii of thousands of kilometers are developed, such "no attack zones" might be meaningless.

quire considerable time and expense. For the next decade and perhaps beyond nations would probably be forced to operate their current low-altitude systems.

Although it is possible that some reconnaissance satellites might be able to function from higher orbits with some degradation of performance, radar satellites—useful in tracking surface ships—would have substantially greater difficulty. Current systems employ active radar, which means that the strength of the return signal decreases as the fourth power of

the range to the target. The substantial increase in range necessary to take advantage of a high-altitude “no-attack” zone would severely degrade the performance of current systems. It is possible that, over time, improvements in technology could solve the problems created by the increase in range. Nonetheless, by the time this occurred new ECM and EOCM capabilities might also be developed that could help to negate systems taking advantage of high-altitude “sanctuaries.”

PROVISIONS RESTRICTING ASAT POSSESSION OR DEPLOYMENT

An agreement which sought to restrict the possession or deployment of ASAT weapons could be either comprehensive or limited. A *comprehensive ban* might prohibit the possession or deployment of any deliberate “anti-satellite system.” A *limited ban*, on the other hand, might allow the possession of some ASAT weapons but not others, or establish limitations on allowable ASAT capabilities or on the number and kind of deployments.

In order to establish a comprehensive ban on the possession or deployment of ASAT weapons, it would first be necessary to come to an agreement as to what exactly was being banned. As explained above, the existence of systems that have an inherent ability to attack satellites complicates the process of eliminating all ASAT *capability*. A ban on all systems with ASAT capabilities would be so broad as to be unworkable since it would include ICBMs, SLBMs, ABMs, and maneuverable spacecraft such as the Shuttle. On the other hand, a ban on deliberate ASAT systems alone might allow the development of non-ASAT systems having sophisticated ASAT capabilities. For this reason, the most effective comprehensive ban on possession and deployment would probably be one which was also accompanied by a prohibition on testing non-ASAT systems in an ASAT mode.

Many types of limited-possession regimes can be imagined. The United States and the Soviet Union might decide to keep the ASATs they are currently testing, but prohibit the possession or deployment of more advanced systems. Alternatively, each side might be allowed to have one designated system in addition to the one they are currently testing; the capabilities of this additional system might or might not be limited (e.g., low-Earth orbit capability only). Still another regime might limit the parties to ground-based ASAT weapons and ban possession of weapons that would be based in space.

In all of these limited-possession regimes additional restrictions on the number and location of allowable ASAT deployments could be added.

Monitoring Compliance With Limitations on Possession and Deployment

A comprehensive ban on the possession or deployment of the existing Soviet ASAT weapon would raise some important monitoring problems. The launch vehicle for the Soviet ASAT is used in several other non-ASAT roles. These launchers will remain available even if the Soviet ASAT weapon is banned.

Since the ASAT weapon itself is small, it would be difficult for the United States to verify with high confidence that the Soviets had not clandestinely retained a stockpile.⁶

A limited possession ban that granted either side the right to possess and deploy the ASAT weapon it was currently testing would raise fewer verification problems. Significant Soviet cheating would involve covertly testing and developing a new and unproven advanced ASAT weapon, rather than simply hiding an existing system. As discussed above, it is likely that such a development program would include some testing requirements that were observable.

Given the small size of the current Soviet ASAT weapon, restrictions on the number of ASAT weapons that could be deployed at each launch site would be difficult to monitor in the absence of onsite inspection. Even onsite inspection would not provide complete security, since ASATs could be covertly stored and easily transferred to the launch area when needed. The United States would have higher confidence at monitoring restrictions on the allowable number of launch sites. Restriction on launch facilities would increase the time between ASAT launches and decrease the probability of sudden, multiple kills. A combination of restrictions on both the allowable number of launch sites and on the number of ASAT weapons that could be stored at each site could reduce the likelihood of a surprise attack or, at minimum, reduce the effect of such an attack.

Utility of Limitations on Possession and Deployment

A comprehensive ban on ASAT possession and deployment is complicated by: 1) the existence of the Soviet, and, in the near future,

the U.S. ASAT weapons; 2) the fact that the lack of possession or deployment could not be monitored with high confidence; and 3) the fear that a ban on possession and deployment—even if monitored with high confidence—would not eliminate the knowledge of how to build these systems, and that the forces might be reconstituted at some time in the future.

Balancing these three concerns is the understanding that for the Soviets to retain some ASAT weapons in violation of a possession or deployment ban would not in itself be threatening—they must also be able to use these ASAT weapons in a way that is militarily significant. Differences of opinion exist as to the military significance of minor violations of a ban on possession and deployment. Some argue that the Soviets must be able to launch a sufficient number of ASAT weapons with sufficient rapidity to gain an important military advantage. To do this, the ASAT weapons and launch vehicles would have to be pre-mated and held in readiness, activities that would probably be observable. Others believe that the Soviets would not have to launch a mass ASAT attack in order to gain important military advantages. They point out that in some limited war scenarios, destroying a very small number of critical satellites could have grave consequences. Therefore, there might not be a need for a large number of observable, pre-mated ASAT weapons and launchers.

Assuming the United States did have advance notice of Soviet ASAT activities, it could respond through diplomatic channels or through a Standing Consultative Committee, if established. Even short-term notice of intent to use ASAT weapons would allow the United States time to maneuver its satellites or take other appropriate action.

The fact that every element of an agreement cannot be monitored with high confidence does not necessarily mean it has no value. It is extremely difficult to monitor the “no nuclear weapons in space” provision of the Outer Space Treaty and yet the United States continues to adhere to it. Presumably, this is because the benefits of the treaty outweigh the risk posed by potential Soviet cheating.

⁶The U.S. ASAT weapon currently under development is quite small. However, the Soviet monitoring task is easier because the U.S. ASAT weapon requires large and distinctive support equipment and because significant expenditures for military facilities, personnel, and weapons procurement would be revealed in the annual authorization and appropriation process of Congress or by the popular press.

Even if a ban on possession and deployment could not be monitored with high confidence it would, at minimum, oblige the Soviets to conduct future ASAT weapons tests covertly. This would complicate maintenance of the current system, make upgrades difficult and advanced ASAT development less likely. The combination of these effects would make U.S. satellite survivability programs more effective and might discourage the use of ASAT weapons.

Space systems with inherent rather than intentional ASAT capabilities would be difficult to restrict by a comprehensive ban on possession or deployment. Nonetheless, such systems pose only a modest threat to critical U.S. assets. Those systems which employ nuclear warheads (e.g., ICBMs, SLBMs, ABMs) might only be used in a terrestrial nuclear war or at the risk of precipitating one. They would also risk damage to the attacker's own satellites. Future maneuverable spacecraft, although capable of some limited ASAT activity, would not be able to provide the rapid, multiple-kill capability likely to be obtained from future dedicated ASAT systems, and are therefore a considerably lesser threat.

A regime which banned only *deliberate ASAT systems* and disregarded systems with

some *inherent ASAT capability* would still be useful in as much as it would reduce the threat of the most highly capable and destabilizing future ASATs systems. Nonetheless, a ban on the possession and deployment of ASAT systems would probably be most valuable if accompanied by a prohibition against the testing of non-ASAT systems in an ASAT mode.

The 1983 Soviet draft treaty contained an example of a comprehensive ban on possession. Article 2(4) of the draft treaty would have required that parties undertake, "Not to test or create new anti-satellite systems and to destroy any anti-satellite systems that they may already have." Given the past statements of Soviet officials and the draft treaties proposed by the Soviet Union, it is likely that the Soviets would be willing to negotiate a comprehensive ban on *possession*. It is less clear whether they would be willing to negotiate some form of limited ban. If their primary concern is protecting all of their space assets, then a limited ban might not be acceptable. If, on the other hand, their purpose in negotiating any ban is to limit the development of more effective ASATs or space-based BMD technologies, then there might be some partial bans that they would find acceptable.

PROVISIONS RESTRICTING ASAT USE

Perhaps the least complicated ASAT agreement would be one that prohibited hostile acts against satellites. Such an agreement would probably not attempt to limit specific ASAT systems, but would instead prohibit the *use* of all ASAT *capabilities*. Although a "no use" agreement could not strictly be considered "arms control," in as much as both parties would be free to develop and deploy any number and kind of advanced ASAT system, it might usefully define what constituted a "hostile act" against a satellite. This agreed definition of "hostile act" might serve to avoid some future conflict brought about by a confusion of intentions. It would also establish a

satellite attack as an unambiguous warning of further aggressive intent.

Although a "no use" agreement might not substantially reduce the threat of ASAT attack, it could serve as a useful component of other, broader arms control agreements. The definition of prohibited acts that might reasonably result from the negotiation of a "no use" agreement could lead to a clearer understanding of the systems capable of performing those acts. This, in turn, might assist in the negotiation of agreements that prohibited the testing, possession, or deployment of ASAT weapons.

Monitoring Compliance With a "No Use" Agreement

Compliance with a "no-use" agreement would be relatively easy to monitor. This is particularly true for the current generation of ASAT weapons. The monitoring task would become slightly more difficult if the Soviets were to follow the U.S. example and develop an air-launched interceptor. This would allow them to launch an ASAT attack outside of the Soviet Union—perhaps even from the western hemisphere if the appropriate facilities were installed in Cuba.

If it were possible to covertly develop ground-based directed-energy facilities or more flexible air-based facilities, these might be used to damage the sensors of a U.S. satellite in such a manner as to mimic an equipment malfunction. This is particularly true when the object of an attack is not to destroy the satellite, but rather to "blind" or "dazzle" delicate sensors.

On the other hand, the effective use of on-board monitoring equipment could substantially reduce this threat. To a limited degree, satellites now have some on-board "state-of-health" monitoring equipment. It is possible to augment these sensors to determine whether a failure is due to an internal flaw or whether it has been externally induced. These sensors might, for example, measure incident laser light, rises in temperature, or sudden accelerations. The inclusion of "state-of-health" monitoring equipment on satellites combined with a future space-based surveillance system could provide the necessary ingredients to verify a "no use" treaty with high confidence.

Utility of a "No Use" Agreement

In order to judge the utility of a "no use" agreement it is first necessary to understand what such an agreement could and could not accomplish. Even if a "no use" agreement could be monitored with very high confidence, in an environment of unconstrained ASAT development, a "no use" treaty might make only a small contribution to protecting U.S. space

assets. Should nations eventually possess directed-energy weapons or space mines with an instantaneous and multiple kill capability, there will be significant advantages to being a first user of these weapons. Nations may find themselves in the position of having to use or lose their offensive space-based assets. If the measure of effectiveness of a "no use" agreement is how well it protects U.S. satellites in an otherwise unconstrained environment, then one would have to conclude such an agreement was of limited value.

Although the U.N. Charter and the Outer Space Treaty both *implicitly* prohibit hostile acts against the satellites of other countries, there may be some value to obtaining a formal agreement that such hostile interference is a violation of international law and potentially a cause of war. A "no use" ASAT treaty would, like the Geneva protocol on use of poisonous gases, establish more clearly the "law of civilized nations." Codifying what is already implicit in international law might serve to inhibit the willingness of nations to attack satellites in a crisis before hostilities have broken out on Earth and perhaps even for some period of low intensity conflict.

Although a "no use" agreement would not, in itself, substantially reduce the risk or the effect of an ASAT attack, it would serve as a useful addition to other, more comprehensive, ASAT limitations. For example, an agreement that restricted ASAT testing would benefit from the clear statement that hostile acts against satellites were forbidden. Such an agreement would assist in developing the principle that the goal of ASAT limitations was to protect space assets and to keep space from becoming an area of unrestrained conflict and not simply to control the development of one or another class of offensive weapons.

It is likely that some type of "no use" agreement would be acceptable to the Soviet Union. It would, of course, be necessary to clearly define what constituted "use" under the agreement. In their 1983 draft treaty, the Soviets defined "use" as meaning "to destroy, damage, disturb the normal functioning or change

the flight trajectory." Although the United States might agree in principle with the intent of such a provision, it is unlikely that it would accept this exact language. The Soviet phrase "disturb the normal functioning" might be interpreted as prohibiting the use of electronic countermeasures, and this interpretation would probably be unacceptable to the United States.

The 1983 draft treaty of the Union of Concerned Scientists (UCS) is similar to the So-

viet draft except the phrase "disturb the normal functioning" is replaced by "render inoperable." The UCS language is, from a U.S. perspective, probably more acceptable, since it would seem to cover only actions that harm the satellite and not those that make its job harder. In the absence of formal negotiations, it is impossible to assess Soviet intentions or willingness to compromise on this point.

PROVISIONS RESTRICTING SPACECRAFT OPERATION AND ORBITS

Whether or not the United States and the Soviet Union agree to restrict ASAT weapons or capabilities it might be useful to negotiate a set of "rules of the road" for military space operations. These rules could serve the general purpose of reducing confusion and encouraging the orderly use of space, or they could be designed specifically to aid in the defense of space assets. Examples of general rules might include agreed limits on minimum separation distance between satellites or restrictions on very low-orbit overflight by manned or unmanned spacecraft. These general rules might also be used to establish new, stringent requirements for advance notice of launch activities. Specific rules for space defense might include declared and possibly defended "keep-out zones," grants or restrictions on the rights of inspection, and limitations on high-velocity fly-bys or trailing. It might also be desirable to establish a means by which to obtain timely information and consult concerning ambiguous or threatening activities.

Precedents can be found for each of the general rules suggested above. The clearest example of international acceptance of "rules of the road" is the 1960 multilateral agreement on "International Regulations for Preventing Collisions at Sea."⁷ This agreement estab-

lished the rule of international conduct on the high seas and provided the basis for the 1972 Soviet-U.S. treaty on the "Prevention of Incidents On and Over the High Seas."⁸ In this latter agreement, the United States and the Soviet Union established more specific rules for the operation of their respective warships.

In the civilian communications field, nations have agreed to work with the International Telecommunication Union (ITU) to develop rules to insure orderly use of the geostationary orbit and the radiofrequency spectrum. Those nations possessing military satellites might wish to establish an organization, or more limited working groups, to develop similar technical rules of conduct for military space activities.

The Chicago Convention of 1945 established the fundamental principle of state sovereignty over territorial airspace.⁹ The 1967 Outer Space Treaty established the equally important principle that space should be freely available for the use and exploitation of all nations.¹⁰ Since the beginning of the space age, nations have wrestled with, but failed to re-

⁷23 U.S.T. 1168; T.I.A.S. 7379.

⁸"Convention on International Civil Aviation" (Chicago 1947), 61 Stat. 1180, 15 U.N.T.S. 295, T.I.A.S. 1591

¹⁰"Treaty on Principles Governing the Activities of States in the Exploration and Use of Outer Space, Including the Moon and Other Celestial Bodies, Jan. 27, 1967 (Article I) 18 U.S.T. 2410, T.I.A.S. 6347.

⁷33 U.S.C. 1051; T.I.A.S. 5813

solve the question of how to characterize the boundary between airspace and outer space.¹¹ As one author has observed, the very important difference between these two regimes is that "states shoot at aircraft not authorized to be in their airspace; they do not shoot at satellites passing over that airspace."¹² This distinction will become increasingly harder to make as maneuverable space vehicles become more capable. Will nations continue to allow overflight of their territory by military spacecraft which are also capable of aerodynamic flight? Practical and internationally consistent "rules of the road" may be necessary to resolve this problem.

Article IV of the "Convention on Registration of Objects Launched into Outer Space" currently requires signatories to supply the Secretary-General of the U.N. with information concerning its space objects and launches. However, since the Convention requires only that the signatories supply this information "as soon as practicable," it is of little use in clarifying ambiguous activities in a timely manner. Article 4 of the "Agreement on Measures to Reduce the Risk of Outbreak of Nuclear War Between the United States of America and the Union of Soviet Socialist Republics" also requires that "each Party . . . notify the other Party in advance of any planned missile launches if such launches will extend beyond its national territory in the direction of the other Party." Unfortunately, since this article does not apply to space launch vehicles it is of little use as a means to protect space assets. As space launches become more numerous and varied, an agreement providing for *timely* notification of launch and information on the characteristics of the vehicle may be essential to avoid crisis through confusion.

International law recognizes that the concept of sovereignty extends to more than a nation's land mass. For example, a country's territorial waters and contiguous airspace are considered to be sovereign and defensible elements of that country. Extrapolating from this concept, one method for protecting satellites would be to negotiate or declare "keep-out zones" around the most critical space assets. The agreement or declaration of these "keep-out zones" might also include the right to defend these zones once declared. Precedent for the concept of "keep-out zones" can be found in the history of the SALT negotiations pertaining to submarines. During the course of these negotiations a number of proposals were discussed such as, "no-submarine zones" which would have prohibited missile-carrying submarines from operating in certain parts of the ocean, and "no-ASW zones" (anti-submarine warfare) that would have allowed the unhindered operation of submarines in select areas to ensure that reliable retaliatory forces would exist to deter a possible first strike.

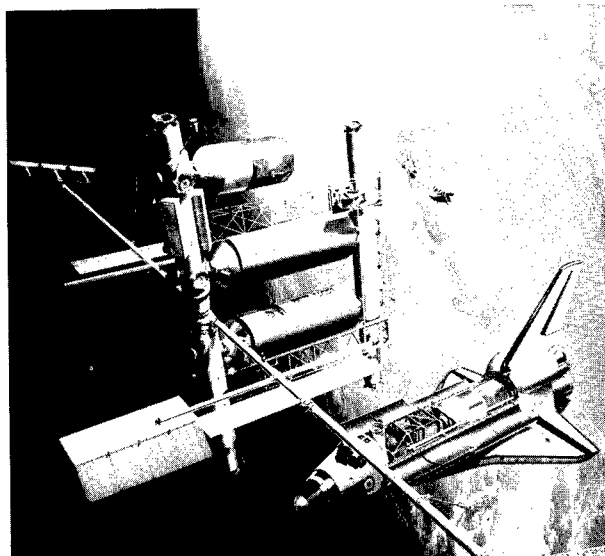

Photo credit: National Aeronautics and Space Administration

Artist's conception of the U.S. Space Shuttle servicing a Space Station. As commercial and scientific space activities increase, internationally accepted "rules of the road" may be necessary to ensure that both military and nonmilitary space activities are conducted in a safe and orderly manner.

¹¹This question has been considered almost annually in the U.N. Committee on the Peaceful Uses of Outer Space but has yet to be resolved. The position of the United States has been that such a delimitation has not been necessary and, indeed, might impede beneficial space activities.

¹²"Anti-Satellite Weapons, Arms Control Options, and the Military Use of Space," William J. Durch, U.S. Arms Control and Disarmament Agency, contract No. AC3PC103, July 1984, p. 3.

Negotiated or declared "keep-out zones" would have to be reconciled with Article II of the 1967 Outer Space Treaty which states, "outer Space . . . is not subject to national appropriation by claim of sovereignty, by means of use or occupation, or by any other means." "Keep-out zones" might be considered by some nations to be contrary to the Outer Space Treaty's ban on "national appropriation." A counter argument might hold that current international practice with respect to communication satellites in geosynchronous orbit already incorporates a variation of the "keep-out zone" principle. Current geosynchronous orbit must be space several degrees apart in order to avoid frequency interference. Therefore, such a satellite precludes the placement of other satellites near its position in the orbital arc.

In order to reduce uncertainty regarding the purpose of certain satellites and the tension likely to result from unauthorized close approach, it might be useful to establish rules regarding inspection, high-velocity fly-by and trailing. Such agreements might allow close approach and inspection under certain circumstances (e.g., prior consent) but might otherwise ban high-velocity fly-by and trailing—either of which could be a prelude to satellite attack.

One of the functions of a regime of rules in space would be to reduce instances where provocative or threatening activities are observed but not explained. To resolve this problem, a forum or a "hot line" might be established through which questionable space activities could be discussed in a timely manner. Precedent exists for this in the 1971 "Agreement on Measures to Reduce the Risk of Outbreak of Nuclear War," which requires the United States and the Soviet Union to notify each other "in the event of signs of interference with [early warning systems] or with related communication facilities, if such occurrences could create a risk of outbreak of nuclear war." The 1971 agreement might be strengthened to require consultation regarding activities that might threaten satellites

and not just activities which create a risk of nuclear war.

Monitoring Compliance With a "Rules of the Road" Agreement

The ability to monitor individual "rules of the road" with high confidence would vary directly with the specific measures adopted. As a general rule, however, monitoring "rules of the road" would be easier than monitoring other "arms control" regimes. The primary purpose of such rules would not be to restrict substantially the activities of the parties, but rather, to make the intentions behind these activities more transparent. Although the degree of protection for U.S. space assets to be gained from a "rules of the road" agreement would be less than from other arms limitation regimes, the costs are also correspondingly less for failure to completely verify compliance. One must assume that in the absence of ASAT arms control, both ASAT development and satellite survivability programs will be given high priority. This being the case, offensive and defensive measures would be available to respond to violations of "rules of the road."

Utility of a "Rules of the Road" Agreement

The "rules of the road" discussed above—if implemented in the absence of restrictions on ASAT weapon development—would not remove the threat of ASAT attack. If they were defended, "keep-out zones" would probably offer the closest thing to security in such a regime. Space mines designed to shadow satellites and detonate on command would lose a great deal of their utility if held at bay by a defended keep-out zone. If these zones were sufficiently large, or if satellites were appropriately shielded, they might even be effective against nuclear space mines. Keep-out zones would be less effective against advanced directed-energy weapons with kill radii of thousands of kilometers. However, these might be controlled by other arms control measures.

"Keep-out zones" combined with defensive satellites (DSATs) would offer substantial—though still incomplete—protection but would likely be extremely expensive. As an alternative to defended "keep-out" zones, the United States might wish to develop redundant systems and an ability to rapidly reconstitute lost assets.

"Rules of the road" would be substantially more effective at encouraging the orderly use of space by the military and at reducing the chances of escalation or misunderstanding in a crisis. Even in the absence of controls on ASAT weapons it would be valuable to have a multinational consensus concerning ambiguous activities such as close-approach, very low-orbit overpass, and high-velocity fly-by. If the "rules of the road" were part of other limitations on ASAT weapons and capabilities they would likely contribute to the effectiveness of these agreements and make their implementation more manageable.

Whether "rules of the road" were negotiable would depend on the specific provisions chosen. The negotiations pertaining to such rules might require the United States, the Soviet Union, and perhaps others, to sit down and discuss secret and extraordinarily sensitive issues relating to the operation of military

space assets. Some rules, such as very low-orbit overflight by manned, reusable vehicles, may be so politically sensitive as to not be amenable to discussion. Other rules, such as "keep-out zones" and minimum separation distance for satellites, may not be desirable because they are not technically possible at altitudes where the majority of current U.S. and Soviet satellites are located. On the other hand, some rules, such as high-velocity fly-by, or close inspection might lend themselves to discussion and agreement.

The United States and the Soviet Union may wish to adopt "rules of the road" as a result of their increased use of space for military—including ASAT—purposes, or because they are engaged in negotiations designed to limit the arms race in space. "Rules of the road" might be an attractive companion agreement to far-reaching limits on ASAT weapon development. On the other hand, in the total absence of ASAT weapon limitations, there would be a need to clarify ambiguous activities before it became necessary to "use or lose" offensive space weapons. The negotiability—or lack thereof—of "rules of the road" can only be discovered as a result of serious negotiation between interested parties.

BMD AND ASAT TREATIES OF LIMITED DURATION

Each of the regimes examined above could be negotiated as a treaty of indefinite or limited duration or, alternatively, as one which remains in force as long as periodic reviews are favorable. Each of these alternatives has its advantages and disadvantages. Treaties of indefinite duration are more effective at discouraging the pursuit of banned activities, yet require a greater degree of foresight regarding the long-term interests of the signatories and can foreclose technological options for the indefinite future.¹³ Treaties of limited duration

allow parties to take advantage of future technological options, yet can encourage aggressive development programs designed to reach fruition at the termination of the designated period. Treaties which call for a periodic reassessment of agreed limitations in theory have great flexibility, yet, in practice, often result in a strong presumption that they should be continued.

¹³Treaties of unlimited duration usually contain a clause which allows the signatories to withdraw from the treaty if their "supreme national interests" are threatened. In addition to "supreme national interest clauses," treaties may also contain specific unilateral or agreed statements regarding specific understandings about related events. For example, The 1972 ABM Treaty contains a unilateral statement by the United States which links the continued viability of the treaty to "more complete limitations on strategic arms."

¹³Treaties of unlimited duration usually contain a clause which allows the signatories to withdraw from the treaty if their "supreme national interests" are threatened. In addition to "su-

The United States might, for example, enter into a treaty limiting ASATs with the explicit and public reservation that we would withdraw from this treaty if and when we were ready to test and deploy a ballistic missile defense system in ways that the ASAT Treaty would forbid. Alternatively, we might take the public position that we intended to restrict our BMD activities so as to remain within the limits of an ASAT Treaty. While the former position would suggest a treaty of limited duration and the latter a treaty of unlimited duration, this need not be the case. It would be perfectly possible to sign a treaty of unlimited duration, with the standard provision allowing for withdrawal, accompanied by a clear statement of some of the conditions under which we intended to withdraw.

From one point of view, the exact language in a treaty regarding its duration is less important than the intentions of the parties. After all, there have been numerous examples of treaties of unlimited duration that were violated soon after they were signed and examples of treaties of limited duration that continued in force after they had expired (e.g., the "Interim Offensive Agreement" signed at SALT I). The real issue is whether the parties believe that adherence to the treaty in ques-

tion continues to be in their national security interest.

The Reagan Administration has recently indicated that it intends to conduct ASAT tests to gather information useful in advanced BMD research.¹⁴ Given the close connection between these two technologies, an ASAT treaty of even limited duration would require modification of current SDI program plans. Thus, to the extent that the United States wishes to maintain the most rapid pace of advanced BMD research within the bounds of the ABM Treaty, such a treaty would not be desirable. Conversely, to the extent that the United States wishes to slow the pace of Soviet BMD research and is willing to defer decisions regarding the testing of space-based or space-directed weapons, an ASAT treaty of limited duration could contribute to that result.

¹⁴The purpose of tests "in an ASAT mode" would be to investigate advanced technologies without violating the ABM Treaty. The Department of Defense recently told Congress that, "To ensure compliance with the ABM Treaty the performance of the demonstration hardware will be limited to the satellite defense mission. Intercepts of certain orbital targets simulating anti-satellite weapons can clearly be compatible with this criteria." "Report to the Congress on the Strategic Defense Initiative," Department of Defense, 1985, app. B, p. 8.

COMPLIANCE MONITORING, VERIFICATION, AND RECOURSE

Verification of compliance with an arms control treaty provision involves three distinct processes: monitoring the activities of other parties to the treaty, interpretation of the information obtained by monitoring, and, assessment of the risk which such activities pose to U.S. security. Each of these processes presents a different set of problems and opportunities to the intelligence community. Should violations or potential violations of treaty obligations be discovered during the verification process, then it becomes necessary to decide what, if any, action is to be taken in response. Verification of compliance and recourse are discussed in greater detail below.

Monitoring

When discussing the ability of the United States to monitor Soviet treaty compliance, it is important to distinguish existing and planned capabilities from potential capabilities. Existing and planned monitoring capabilities are described in chapter 4. Some of the existing systems used to monitor compliance with SALT and other arms control agreements would be useful for monitoring compliance with possible ASAT arms control provisions.¹⁵

¹⁵Some of these capabilities have been described in general terms by Congressman Les Aspin in "The Verification of the SALT II Agreement," *Scientific American*, vol. 240, No. 3, February 1979, pp. 38-45.

For example, capabilities to monitor the construction and dismantling of ICBM launchers—the number of which is constrained by the SALT II agreement—could also be used to monitor the construction and dismantling of launchers for boosters used for ASAT weapons.

By investing in new monitoring systems and personnel, future monitoring capabilities can be made more comprehensive than existing capabilities. To a limited extent, one can actually “buy” more monitoring capability. (See table 6-1). However, such additional capabilities would, in most cases, require years of work and substantial expenditures of funds. As in weapon system procurement, it will be necessary to judge “how much is enough”—i.e., to determine the level of investment above which the value of monitoring capability improvement obtainable per dollar ceases to be worth a dollar.

The fact that future monitoring systems could be more capable than current systems does not mean that all monitoring problems can be solved by spending more money on advanced technologies. Some activities will always be unmonitorable (e.g., some forms of underground testing), other dual-purpose activities (e.g., manned spaceflight) will often be difficult to characterize. Although future technologies will increase our ability to monitor the activities of other countries, similar technologies may make the job of treaty verification more difficult. Specific examples of these problems are presented above in the discussions of specific treaty provisions.

Interpretation

Once indications of a potentially prohibited activity have been detected by monitoring systems, the data must be further interpreted to determine the intent of the activity and how the activity affects specific treaty agreements. For example, suppose that while a space-weapon ban is in effect, the deployment or construction of a large mirror is observed in space. In this case, the monitoring data might be scrutinized to determine whether the mirror was capable of reflecting intense laser beams

and changing its pointing direction quickly—as a prohibited weapon system might—or whether, instead, it was only capable of reflecting low-intensity radiation and changing its pointing direction slowly, as communication system or telescope components might.¹⁶ The ability to make such a determination would depend both on the sophistication of the monitoring system employed and prior knowledge regarding similar activities.

Even if the monitoring system provides data sufficient to clearly identify the nature of a questioned activity, it still remains to be determined whether that activity is prohibited by the language of the relevant treaty. In the example of a mirror deployed in space, there would remain the question of whether deployment in space of any large mirror capable of reflecting intense laser beams would be a violation. Since similar mirrors have been proposed for peaceful purposes (e.g., propulsion of laser-powered rockets¹⁷), even if the relevant agreement defined weapons in terms of their capabilities rather than intended uses, there could be ambiguity as to the legality of deploying such mirrors.

When ambiguities are foreseen, treaty language can be worded to avoid them. However, history has demonstrated that it is extremely difficult to foresee all the significant ambiguities that could arise in an arms control agreement.

Assessment

If monitoring data are interpreted to indicate that an activity prohibited by a treaty (or possibly inadvertently allowed by ambiguity of the treaty) is taking place (or about to take place), the risk which the activity poses to U.S. security must be assessed. This assessment must take into consideration at least three factors: 1) the threat to U.S. national security posed by the specific violation; 2) assuming the

¹⁶The large deployable reflector (LDR) under development by NASA is an example of such a component.

¹⁷R.R. Berggren and G.E. Lenertz, “Feasibility of a 30-Meter Space Based Laser Transmitter,” NASA-CR-134903, 1975 [NTIS accession number N-7611421].

violation, the extent to which the relevant treaty still contributes to U.S. national security; and 3) the ability of the United States to take actions which will prevent, mitigate, or compensate for damage that might be caused by the violation. The result of such an assessment will often imply the appropriate nature of the recourse to be pursued.

Recourse

Given the many different activities that ASAT arms control could restrict and the numerous ways that such agreements could be violated, it is difficult to make generalizations about how the United States might or should respond. Faced with a clear violation of a major treaty provision that seriously jeopardized U.S. national security, the United States would be wise to withdraw from the treaty in question. If, on the other hand, the existence of a violation was uncertain and it pertained only to a subsidiary portion of an otherwise valuable treaty, then it might be appropriate to seek consultation to resolve this particular activity while leaving the treaty otherwise intact.¹⁸ Alternatively, unilateral defensive countermeasures or R&D on treaty compliant

offensive measures might be pursued to hedge against breakout. The hardest questions are those that arise somewhere between these two examples.

ASAT arms control raises a number of questions common to all high-technology treaty restrictions. For example, if one party violates a test ban on advanced directed-energy ASATs and then, when confronted with the violation, declares its intent not to repeat this violation, what is the appropriate response? Some would argue that the damage has been done. One side has had the opportunity to verify a technology which it may have been developing covertly over a period of years. The side which remained in compliance has lost not only the information it could have gotten from similar tests, but potentially, years of research experience. Others might argue that limited testing or minor ambiguities offer no real and enduring military advantage.

Other responses to clear or uncertain treaty violations include negotiating modifications to the agreement or matching cheating with identical or equivalent conduct. Negotiating modifications can be a long and contentious process, particularly if the negotiations require one party to admit to treaty violations or ambiguous conduct. Given the differences between Soviet and U.S. force structure and technology base, matching cheating with identical conduct is often not a useful alternative. For example, the United States may not desire to build a Krasnoyarsk-style radar. On the other hand, matching cheating with equivalent conduct (the so-called "parallel interpretation" alternative) runs counter to notion that a treaty should have one common understanding which is accepted by both parties.

¹⁸Others have argued that the mere fact that a treaty has been violated is as important as the national security impact of the violation. For example, Colin Gray writes:

The Soviet noncompliance issue is not important as a matter of ethics or because the sanctity of international legal norms must be upheld . . . Nor is Soviet cheating primarily important in terms of military advantage and disadvantage . . . (T)he greatest danger . . . results from the loss of U.S. credibility. . . . (W)ar is more likely to explode out of a mutual diplomatic miscalculation (than a military imbalance). That miscalculation could be rooted . . . in a Soviet lack of respect for the quality of determination in U.S. policy.

Colin Gray, "Moscow is Cheating," *Foreign Policy*, No. 56, fall 1984, pp. 141-152.

Chapter 7

**Comparative Evaluation
of ASAT Policy Options**

Contents

	<i>Page</i>
Policy Overview	125
ASAT Policy Choices	125
Alternative Legal/Technical Regimes	125
Regime 1: Existing Constraints	127
Legal Regime	127
Offensive Posture	128
Defensive Posture	128
Net Assessment	129
Regime 2: A Comprehensive Anti-Satellite and Space-Based Weapon Ban	130
Legal Regime	130
Offensive Posture	131
Defensive Posture	131
Net Assessment	131
Regime 3: An ASAT Weapon Test Ban and Space-Based Weapon Deployment Ban	132
Legal Regime	132
Offensive Posture	132
Defensive Posture	133
Net Assessment	133
Regime 4: "One Each/No New Types" Regime	134
Legal Regime	134
Offensive Posture	134
Defensive Posture	135
Net Assessment	135
Regime 5: Rules of the Road	136
Legal Regime	136
Offensive Posture	138
Defensive Posture	138
Net Assessment	138
Regime 6: Space Sanctuaries	138
Legal Regime	138
Offensive Posture	139
Defensive Posture	139
Net Assessment	139
Regime 7: A Space-Based BMD Regime	140
Legal Regime	140
Offensive Posture	140
Defensive Posture	140
Net Assessment	141

Table

<i>Table No.</i>	<i>Page</i>
7-1. Effect of Regimes on ASAT Development and Arms Control	126

Comparative Evaluation of ASAT Policy Options

POLICY OVERVIEW

ASAT Policy Choices

Over the next 5 years, the United States will have to make key decisions regarding research and development programs for anti-satellite weapons and countermeasures and for ballistic missile defense (BMD) systems. In addition, the United States must also consider whether it wishes to seek agreement with the Soviet Union to halt or limit the development of certain weapons that would operate from space or against space objects. This chapter analyzes the relationships between offensive and defensive weapons programs and arms control. In so doing, it utilizes the technology discussions contained in chapters 3 and 4 and the discussions of arms control found in chapters 5 and 6.

As discussed in chapter 6, those regimes which require negotiated arms control agreements could be either of limited or unlimited duration. Opponents of developing BMD systems might prefer an agreement of unlimited duration. Agreements of limited duration—perhaps 5-10 years—might be attractive to proponents of advanced BMD research if they could be fashioned so as not to interfere with plans to develop and test prototype BMD weapons. Such agreements would have the added benefit of temporarily constraining the development or testing of advanced ASAT weapons which could attack space-based BMD system components.

Alternative Legal/Technical Regimes

This chapter considers possible arms control provisions, ASAT postures, and countermeasures together as packages in order to examine their interaction. Since there are many conceivable packages, it is necessary to select a

limited number for analysis. These packages have been constructed so that each will have at least one advantage over the others considered and so that each contains elements which might reasonably be expected to coexist in the same proposal. Consideration of these regimes is intended to facilitate assessment of the effectiveness and desirability of different combinations of ASAT and BMD technology development, satellite survivability, and arms control.

The seven regimes considered in the remaining sections of this chapter are¹:

1. **Existing Constraints.** The first regime is defined by treaties and agreements presently in force. The ways in which this legal regime would affect technology developments designed to protect U.S. satellites or to place Soviet satellites at risk will be examined.
2. **A Comprehensive Anti-Satellite and Space-Based Weapon Ban.** Regime two could be established by adhering to treaties and agreements presently in force and, in addition, agreeing to forgo the possession of deliberate anti-satellite weapons, the testing—on Earth or in space—of any deliberate ASAT capability, the testing in an “ASAT mode”² of systems with inherent ASAT capabilities, and deployment—on Earth or in space—of any ASAT weapon.
3. **An ASAT Weapon Test Ban and a Space-Based Weapon Deployment Ban.** The third

¹These regimes might usefully include elements not discussed here. For example, regimes 2, 3, 4, and 5 might also include a “no-use” provision which would prohibit the parties from destroying or “rendering inoperable” each others satellites.

²Testing in an “ASAT mode” would include tests of land-, sea-, air-, or space-based systems against targets in space or against points in space.

regime could be created by adhering to treaties and agreements presently in force and, in addition, agreeing to forgo testing in an "ASAT mode" and the deployment of any weapon in space. This regime differs from regime 2 most importantly in that it would *not* ban possession or testing—on *Earth*—of deliberate ASAT weapons.

4. **A "One Each/No New Types" Regime.** Regime 4 includes arms limitation provisions which would permit the United States and the Soviet Union to test and deploy their current ASATs but would prohibit testing of more advanced systems. Advanced systems prohibited would include those capable of operating or attacking targets at higher altitudes and those that would be deployed in space. For the purposes of this assessment, the U.S. MV will be considered to be the only deliberate "current" U.S. ASAT.
5. **Rules of the Road.** The fifth regime illustrates the advantages and disadvantages of establishing "keep-out zones" around individual, high-value satellites.
6. **Space Sanctuaries.** Regime 6 would provide high-altitude sanctuaries where satellites could operate but where the testing or deployment of weapons would be forbidden.
7. **A Space-Based BMD Regime.** The seventh regime might result from U.S. or Soviet withdrawal from the ABM Treaty followed by the deployment of space-based BMD systems.

As table 7-1 demonstrates, the regimes discussed here can be characterized both by the extent to which they rely on negotiated arms controls and by the extent to which they allow or encourage ASAT development. With the exception of the "Existing Constraints" and the "Space-Based BMD" regimes, all other regimes involve some type of arms control. With the exception of the "Comprehensive Anti-satellite and Space-Based Weapon Ban," and perhaps, the "ASAT Weapon Test

Table 7-1.—Effect of Regimes on ASAT Development and Arms Control

	Restrict with arms control ¹	Develop ASAT weapons
Existing constraints	No	Yes
Comprehensive ASAT and space-based weapon ban	Yes	No
Test ban and space-based weapon ban	Yes	Yes/No ^a
One each/no new types	Yes	Yes ^b
Rules of the road	Yes	Yes ^c
Space sanctuary	Yes	Yes ^c
Ballistic missile defense	No	Yes

^aIn this regime ASAT weapons could be developed, tested, and deployed on Earth but not in space. The United States could pursue ASAT development within the bounds of the treaty, or it could forego ASAT development entirely.

^bAll ASAT weapons other than "current types" could not be tested or deployed in space.

^cDevelopment and deployment optional but strongly supported by advocates of this regime.

Ban and Space-Based Weapon Deployment Ban," all other regimes assume some level of ASAT development. These regimes demonstrate that although anti-ASAT arms control arguments and pro-ASAT weapon arguments are related, there are many distinguishing features. ASAT arms control proponents believe that an ASAT treaty is in the national interest; those who support ASAT weapon development believe that this also is in the national interest. However, ASAT arms control proponents do not necessarily oppose all types of ASAT development and ASAT weapon proponents do not necessarily oppose all types of ASAT arms control.

Although the individual regimes vary considerably, all of them should be assessed with two important considerations in mind:

1. **First, if we wish to continue to use space for military purposes, a commitment to satellite survivability is essential whether or not any arms limitation agreements are in force.** The existence of space systems with some inherent ASAT capability makes it impossible to ban the ability to attack satellites. Therefore, even under the most restrictive ASAT arms control regime, programs for satellite survivability and countermeasures must be pursued. In the absence of arms control limitations on

ASATs, ensuring satellite survivability will be a more demanding task.

2. **Second, the United States should exercise caution in its reliance on space assets to perform tasks essential to the national security.** No matter what arms control or satellite survivability measures are taken,

there will always be some risk that critical satellites can be destroyed or rendered inoperable. The value of continued and future reliance on space systems must be balanced against the probability that such assets may not be available in a conflict situation.

REGIME 1: EXISTING CONSTRAINTS

Legal Regime

The United States could decide that there are no additional arms control limitations relating to space weapons that are in its national security interest. If so, development of anti-satellite and space-based weapons by the United States and the U.S.S.R. could continue unrestrained except by the Limited Test Ban Treaty, the Outer Space Treaty, and the ABM Treaty.³

Even in the absence of new arms control limitations there are restrictions on what the United States and the Soviet Union can do in space. As discussed in chapter 5, under existing international law and the treaties to which the United States is a party, the following activities are already banned:

- **Unprovoked Attack on Another Country's Satellite:** Subject to the right of individual or collective self-defense, Article 2 of the U.N. Charter prohibits the use or threat of force. A similar sentiment is to be found in Article III of the 1967 Outer

Space Treaty. The SALT and ABM Treaties also prohibit interference by either state with space assets used by the other to monitor those treaties.

- **Placement of Nuclear Weapons in Orbit:** Article IV of the 1967 Outer Space Treaty (OST) prohibits orbiting nuclear weapons. This would include nuclear "space mines" and, presumably, ASATs that used a nuclear explosion as a power source.
- **Detonation of Nuclear Weapons in Space:** The 1963 Limited Test Ban Treaty (LTBT) prohibits nuclear weapons tests or other nuclear explosions in space. This would prohibit the full testing of ASATs that use nuclear explosions for destruction or as a power source.
- **Development, Testing, or Deployment of Weapons Capable of Countering Strategic Ballistic Missiles, or Their Elements in Flight:** Space-based weapons sophisticated enough to "counter strategic ballistic missiles or their elements in flight" are banned under the terms of the 1972 ABM Treaty. This establishes a somewhat vague upper limit on the capabilities of advanced ASAT weapons.

To summarize, the existing international legal regime prohibits the use of ASAT capability except in national or collective self-defense, the testing or deployment of space-based weapons with strategic BMD capability, and the testing in space or deployment in orbit of nuclear space mines or ASATs that

³The unratified Threshold Test Ban Treaty, and the unratified SALT II Treaty, if adhered to, would supply additional restrictions. The Threshold Test Ban Treaty, which was signed in 1974, prohibits testing *on Earth* of nuclear weapons with a yield greater than 150 kilotons. Should a nuclear ASAT weapon require a nuclear explosive of greater yield than this, it could not be fully tested without violating the Threshold Test Ban Treaty. Under Article IX of the Salt II Treaty, the parties agreed not to develop, test, or deploy "systems for placing into Earth orbit nuclear weapons." This might be interpreted to include nuclear ASAT weapons.

would require a nuclear detonation as a power source. The existing regime places few restrictions on the current ASAT research and development programs of either the United States or the Soviet Union.

Offensive Posture

In the absence of further restrictions, the following weapons could be *developed, tested, and deployed* as deliberate ASAT weapons by either the United States or the Soviet Union, *if deployed in compliance with the ABM Treaty* (i.e., so as not to be capable of countering strategic ballistic missiles or their elements in flight)⁴:

- **Coorbital Interceptors:** Ground-launched, nonnuclear coorbital interceptors—e.g., the current Soviet ASAT—are allowable under the existing regime. Ground-based nuclear systems could be developed and deployed but not tested in space. There are no restrictions on nonnuclear coorbital interceptors predeployed as space mines.
- **Direct-Ascent Interceptors:** Ground-launched or air-launched direct-ascent interceptors—e.g., the U.S. ASAT being developed—are allowable. Direct-ascent interceptors carrying nuclear weapons could be developed and deployed but not tested in space.
- **Ground-Based or Airborne Lasers:** There are no restrictions on nuclear or nonnuclear ground based lasers, or on airborne lasers that would not require a nuclear explosion in the atmosphere.

⁴The constraint that ASAT weapons not be deployed so as to be capable of countering strategic ballistic missiles or their elements in flight is restrictive, but several deployment schemes can be conceived which would be both lawful and useful. For example, a neutral particle beam weapon of relatively low power might be deployed in geosynchronous orbit for ASAT or DSAT purposes. It might be capable of damaging an enemy satellite or ASAT several hundred kilometers away within several seconds, but incapable of damaging a distant ballistic missile during its flight time of a few minutes. Deployment of such weapons might also be allowed in low orbit, if the U.S.-Soviet Standing Consultative Commission—which was established by the ABM Treaty to consider allegations of treaty violations—should agree that such weapons, if never tested as BMD systems, could not reasonably be expected to have a significant BMD capability.

- **Space-Based Lasers:** Nonnuclear, space-based lasers are allowable.
- **Space-Based Neutral Particle Beam Weapons:** There are no restrictions on space-based neutral particle beam weapons.
- **Maneuverable Spacecraft:** Although not necessarily “deliberate” ASAT systems, maneuverable spacecraft could be given substantial ASAT capabilities under the existing regime.

In addition to these deliberate ASAT systems, other weapon systems such as ICBMs or ABMs that have some ASAT capability could be developed and deployed, but could not be completely tested as ASAT weapons. Such systems could be tested in space as long as they were not detonated. The SALT agreements and the ABM Treaty do place other restrictions on ICBMs and ABMs.

Defensive Posture

The United States and the Soviet Union could develop, test, deploy, and use defensive measures such as hiding, deception, evasion, hardening, and proliferation without legal restraint in the existing regime. In addition to such passive countermeasures, nondestructive active countermeasures such as electronic countermeasures (ECM) and electro-optical countermeasures (E-OCM) could also be used. ECM and E-OCM are likely to be available and inexpensive and are unlikely to be restricted by arms control agreements; however, these countermeasures could be defeated at a reasonable cost.

Many destructive active countermeasures would also be allowed under the present regime. Satellites could be given a self-defense capability (shoot-back) or provided with an escort defense (DSAT). The current ASAT interceptors being developed by the United States and the Soviet Union (respectively, the U.S. Air Force Miniature Vehicle and Soviet coorbital interceptor) are not capable of attacking each other. However, many advanced ASAT weapons that could be built in the current regime would have *some* effectiveness against *some* types of ASATs. For example,

a space-based neutral particle beam weapon, in addition to its ASAT role, could also be used as a DSAT to provide "enclave defense"—i.e., to defend a number of distant satellites from other weapons such as coorbital or direct-ascent interceptors or continuous-wave lasers. However, neutral particle beam weapons deployed as DSATs could not shoot back effectively at larger neutral particle beam ASATs, nor could they shoot back effectively at expendable single-pulse weapons such as pre-deployed nuclear "space mines" or some nuclear or nonnuclear directed-energy weapons.

Moreover, if shoot-back is to be effective, space objects with known or suspected ASAT capabilities would have to be fired upon while still some distance from U.S. satellites believed to be in danger. As discussed above, attacking an approaching spacecraft is prohibited by international law except in self-defense and one could not be certain that the approaching spacecraft had a hostile intent until it was too late. Hence, active defense against suspected "space mines" might be considered to be unlawful in the existing regime, although deployment of means for such defense may not be.

Neither passive nor active countermeasures could guarantee the survival of satellites attacked by some advanced directed-energy weapons. Although, as discussed in chapter 4, the cost of destroying small, inexpensive satellites and decoys with advanced directed-energy weapons might exceed the cost of building such satellites and decoys. Security for large and expensive satellites might ultimately have to rely on an attempt to deter ASAT attacks by credibly threatening retaliation against enemy space-based or terrestrial assets. A credible retaliatory capability would require a means of discovering that U.S. satellites had been attacked and identifying the attacker. This would probably require attack sensors mounted on satellites and a space-based surveillance system to track and distinguish ASATs from meteorites or space debris. The latter could also be used to verify compliance with future ASAT arms control agree-

ments, if any, or for targeting future ASAT (or DSAT) weapons, if any.

Net Assessment

Treaties and agreements presently in force create no significant barrier to the development, testing, and deployment of very capable, nonnuclear ASAT weapons.⁵ The current regime also allows a wide range of active and passive countermeasures, including the development of satellites capable of defending themselves by striking at attacking ASAT weapons.

The primary advantage of the current regime is that it allows the almost unrestrained application of U.S. technology to the related problems of protecting U.S. satellites and placing threatening Soviet satellites at risk. Under this regime, the United States would be free to use its comparative advantage in advanced technology to keep pace with expected developments in Soviet ASATs and other military satellites. Advanced U.S. ASATs might discourage the development of more capable Soviet military satellites designed to place U.S. terrestrial assets at risk. In addition, the United States would be free to respond to Soviet ASAT weapons with increasingly sophisticated defensive weapons and countermeasures, thereby reducing the probability that the Soviets could successfully use their intentional or inherent ASAT capabilities. Effective ASAT capability could also give the United States a powerful countermeasure against potential Soviet space-based BMD systems.

In addition, research and development on new ballistic missile defense technologies can also proceed without the constraints that might be imposed by certain ASAT arms control regimes. Testing of advanced ASATs could provide valuable information that would contribute to the development of very capable BMD systems. Such testing in the "ASAT

⁵ASAT weapons capable of operating in an "ABM mode" are, of course, limited by the ABM treaty. See discussion, *supra*, p. 127.

mode" could allow some research to go forward that, if designated as BMD research, might be considered to be inhibited by the ABM Treaty.

The primary disadvantage of the current regime is that it might lead to an expensive and potentially destabilizing arms race in space. Rather than protecting satellites, a competition in space weapons might severely reduce their military utility. Under conditions of unrestrained competition, security might be purchased only at the price of a substantial and sustained commitment to the development of increasingly sophisticated offensive and defensive space weapons. In such an environment, ensuring the survivability of satellites would require more than simple hardening or evasion. Costly measures might have to be taken such as the deployment of precision decoys, pre-deployed spares, or the ability to quickly reconstitute ones space assets. Satellites capable of defending themselves or a companion satellite might also have to be developed and deployed.

Should space mines or directed-energy weapons be deployed, they might be capable of the almost instantaneous destruction of a large number of critical satellites and ASATs. This could force nations into a situation in which they must "use or lose" their own pre-deployed space weapons. This might supply the incentive to escalate an otherwise manageable crisis. If missile early warning and communication satellites were highly vulnerable, crisis stability might be lessened. The malfunction

of such satellites could be misinterpreted as a sign of imminent attack, since potential nuclear aggressors would find such satellites to be attractive targets.

Another potentially destabilizing factor is that some satellites (particularly communication satellites) play a dual role—they are intended to be force multipliers in a conventional war, yet they are to play a key role in managing a conflict so as to avoid unwarranted escalation. In the event of a conventional war, the possessor of a capable ASAT system would have a strong incentive to attack satellites that were providing support to conventional enemy forces. Destruction of these satellites, however, might contribute to escalation from conventional to nuclear war.

An unrestrained competition in ASAT weapons would also increase the risk posed to space-based ballistic missile defense systems. Such systems are likely to have many critical assets based in low-Earth orbit. So situated, extensive precautions would have to be taken to protect them from even modest ASAT weapons.

It is possible that an ASAT weapon competition could also inhibit the use of space for commercial and scientific purposes. Manned space stations would be quite vulnerable to ASAT attack. Should considerable ASAT testing take place, the resulting debris could prove harmful to scientific and commercial satellites.

REGIME 2: A COMPREHENSIVE ANTI-SATELLITE AND SPACE-BASED WEAPON BAN

Legal Regime

This regime could be established by adhering to treaties and agreements presently in force and, in addition, agreeing to forego the possession of deliberate anti-satellite weapons, the testing—on Earth or in space—of any deliberate ASAT weapon, the testing in an "ASAT mode" of systems with inherent ASAT capa-

bilities, and the deployment—on Earth or in space—of any ASAT weapon.⁶ In addition, the U.S.S.R. would be required to destroy all its

⁶Such an agreement might resemble the draft treaty proposed to the United Nations by the U.S.S.R. in August of 1983, except the testing or use of manned spacecraft for military purposes would not, in general, be banned as proposed in Article 2 of the 1983 Soviet draft treaty. (U.N. Document A/38/194, Aug. 23, 1983). The fifth provision of Article 2 of this proposed

coorbital interceptors and the United States would be required to destroy the direct-ascent interceptor it is currently developing.

Offensive Posture

In this regime, the United States could not maintain any deliberate ASAT weapons, whether dedicated or multi-role, nor would the U.S.S.R. be allowed to do so. Space systems with inherent ASAT capabilities such as ICBMs, ABMs, and maneuverable spacecraft would still be allowed, but they could not be tested in an "ASAT mode."

Defensive Posture

Under a comprehensive ASAT ban the United States would retain the right to deploy and use passive countermeasures such as hiding, deception, evasion, hardening, and proliferation. The United States would not be allowed to develop, possess, test, or deploy weapons for satellite self-defense, defensive satellites (DSATs), or other systems intended to have anti-satellite capabilities, even for defensive purposes.

If the U.S.S.R. complied fully with the letter of such a comprehensive ASAT ban, the risk posed to U.S. satellites would be limited to the risk posed by possible Soviet use of ICBMs, SLBMs, ABM interceptors, and possible future highly maneuverable spacecraft. If U.S. satellites were hardened against the effects of nuclear explosions to a modest degree, only low-altitude U.S. satellites would be at significant risk of damage by such inherent ASAT capabilities, and then primarily at the nuclear level of conflict. Assuming Soviet compliance, U.S. warning and communications

satellites in high-altitude orbits would enjoy a high degree of security in this regime.

Net Assessment

Although this regime would contain the most far-reaching arms control provisions and therefore might be most effective at preventing the development of new and more threatening ASAT weapons, it would have the disadvantage of being the most difficult to verify. Unlike an ASAT Test/Space-based Weapon Deployment Ban (regime 3), a comprehensive ban would prohibit *possession* of ASAT weapons *on Earth*. Because it is difficult to obtain information about Soviet military affairs, the United States would have to assume that the Soviet Union could possess some number of their current ASAT weapon.

The current Soviet coorbital interceptor is a relatively small spacecraft launched on much larger, general-purpose boosters. Maintaining such boosters and their launchpads would be allowed, and it would have to be assumed that the U.S.S.R. would continue such activities. Construction of additional boosters and launchpads would also be allowed by an ASAT ban of the type considered here. Hence the U.S.S.R. could maintain and even expand its ASAT force with some confidence that the United States could not gain *unambiguous evidence of a violation* of an ASAT possession ban. However, even if the U.S.S.R. maintained some coorbital interceptors, it could not test them without risking almost certain detection, and in time the confidence of Soviets in a long-untested and never perfected ASAT weapon might erode.

There would always be the possibility that the Soviets might develop a new type of ASAT weapon with the intention of using it, without prior testing, *in extremis* (e.g., if anticipating an imminent attack). For example, the U.S.S.R. might equip an existing booster or satellite vehicle with a nuclear explosive—either an isotropic nuclear weapon or possibly a nuclear directed-energy weapon—and maintain it in readiness for launch or actually launch it into space. The military utility of

treaty would obligate parties "not to test or use manned spacecraft for military, including anti-satellite, purposes." If this provision were stricken or changed to read "not to test or use manned spacecraft for anti-satellite purposes," the resulting draft treaty, if acceded to by the United States and the U.S.S.R., would establish a regime of the type considered in this section. The fifth provision of Article 2 of the proposed Soviet draft treaty would obligate parties "Not to test or create new anti-satellite systems and to destroy any anti-satellite systems they may already have."

such untested systems would be questionable, particularly if the United States aggressively pursued available satellites survivability measures.

Since the United States might agree to a comprehensive ASAT ban only after considerable political friction over question of compliance and verification, it would be important to consider how such a ban might make a greater contribution to U.S. national security than a ban on ASAT testing and space-based weapon deployment (regime 3). The purpose of both bans would be to prevent the use of ASATs, or, at minimum, to reduce the probability that an ASAT attack would be effective. An ASAT test ban would primarily affect weapons reliability, while an ASAT possession ban, if observed, would affect both availability and reliability. It is conceivable that the

risk posed by possible illegal Soviet use of ASAT weapons might be somewhat lower in a regime in which the Soviets could not lawfully possess ASAT weapons. Presumably, the inability to overtly possess ASAT weapons would diminish one's ability to use them effectively. Furthermore, an absolute ban on possession might make it less likely that the current generation of ASAT weapons could be upgraded and held in readiness in significant numbers.

However, if the United States could only be confident that the Soviets were complying with a treaty to the extent we could verify compliance, then the United States would not have confidence that this regime offered any greater protection to our satellites than does regime 3 (test ban and space-based weapons ban).

REGIME 3: AN ASAT WEAPON TEST BAN AND SPACE-BASED WEAPON DEPLOYMENT BAN

Legal Regime

This regime would ban what can be monitored with greater confidence—testing in an “ASAT mode”⁷ and ASAT deployment in space. Everything that is prohibited under the current regime would continue to be prohibited. In addition, further testing—in space—of the current Soviet coorbital interceptor and the U.S. direct-ascent interceptor would be prohibited, as would the placement of any weapons in space. Unlike regime 2, this regime would not attempt to ban testing, possession, or deployment of ASAT weapons *on Earth*.

Offensive Posture

Although they could not be tested *overtly* in an “ASAT mode,” a number of weapons which have some limited ASAT capability already exist or could be developed. ICBMs, ABMs, and maneuverable spacecraft already

exist and have inherent ASAT capabilities which pose some threat to satellites. It might be possible to increase the ASAT potential of these systems without violating a ban on the testing of ASAT weapons. In addition, upon entry into force of a ban on ASAT testing, the United States and the U.S.S.R. would possess deliberate ASAT weapons which would have undergone some developmental testing, although possibly not enough to perfect their designs. Such weapons could be maintained in partial readiness. However, without operational testing for reliability evaluation and training purposes, confidence in the effectiveness of such weapons would probably degrade in time.

Advanced ASAT weapons such as neutral particle beam weapons or x-ray lasers could be developed and maintained in partial readiness, but could not be completely tested. Confidence that such weapons would perform adequately if used might be so low that one would not rely on them in an aggressive first strike nor find it cost-effective to develop them for that purpose. On the other hand, one might

⁷Testing in an “ASAT mode” would include tests of ground-, air-, sea-, or space-based systems against targets in space or against points in space. Testing on the ground of ASAT systems or components would not be prohibited.

use them, if attacked, to degrade enemy capabilities supported by satellites, and might find it cost-effective to develop them for that purpose. That is, the discrepancy between offense conservatism and defense conservatism might decrease the risk which untested weapons could pose if possessed by an aggressive nation.

Defensive Posture

In this regime, testing and deployment in space of advanced ASAT weapons would be prohibited but might be attempted by the U.S.S.R. covertly or after a breakout.⁸ Hence the choice of passive countermeasures in this regime would be influenced by the same considerations which favor deception and modest nuclear hardening in the existing regime. Such measures would be more effective, however, in a test-ban regime because it could be assumed that the ASAT threat would be reduced to some degree by the arms control provision. Passive countermeasures would also be more important in this regime, because destructive active security measures—e.g., shoot-back with reliable, tested DSAT weapons—would not be an option. Deep-space surveillance would be even more desirable in this regime than in the existing regime, because of the need to monitor compliance as well as for its role in providing attack assessment information. Hence, in a test-ban regime, attack sensors, space-based LWIR sensors, satellite decoys, and modest nuclear hardening would be at least as desirable, as in the existing regime, if not more so.

Nondestructive active countermeasures such as ECM and E-OCM would be desirable, if not

inherent, in a test-ban regime, just as in the existing regime. Destructive active countermeasures, on the other hand, would be severely constrained: new ASAT weapons useful as DSATs could be developed but could not be tested nor deployed in space. An untested NPB or XRL built and readied for quick launch and use as a DSAT could not be responsive enough to use for defensive shoot-back against expedient ASAT weapons such as ICBMs but might have value if maintained for retaliatory shoot-back.

Net Assessment

A negotiated ban on the testing of weapons in space or against space objects would limit the nature and extent of U.S. and Soviet arms competition in space. Advanced ASAT directed-energy weapons which could threaten high-altitude satellites with prompt destruction could not be lawfully tested and attempts to extensively test such weapons covertly would probably be detectable. Although such a ban could not eliminate all threats to satellites, it would substantially reduce the cost and complexity of ensuring a reasonable level of satellite survivability. The United States would still benefit from hardening its satellites to some extent and deploying spares and decoys, but the more elaborate, expensive, and possibly ineffective precaution of developing and deploying DSATs would be prohibited and, indeed, less attractive. In the absence of reliable, effective ASATs, satellites would be of greater utility since the United States might have higher confidence that they would be available when needed.

Relative to the existing regime, the primary advantage of a regime banning testing of ASAT capabilities and deployment of space-based weapons would be that highly valued U.S. satellites in higher orbits—e.g., the future MILSTAR system—could be protected with some confidence from advanced ASAT weapons, especially if protected as well by passive countermeasures. The fact that advanced ASATs could not be overtly tested would reduce the probability that they would be devel-

⁸Although deployment of an NPB in space—a prerequisite for testing—would probably be observable, maintaining an untested NPB weapon on Earth in readiness for quick launch might not be, and would be allowed. Maintaining an untested XRL weapon on Earth in readiness for quick launch might also be difficult to detect and would also be allowed under the terms of an ASAT test and SBW deployment ban. Illegal deployment of an untested XRL in space would be difficult and costly to observe. However, an enemy could have little confidence in the reliability and performance of untested NPB or XRL weapons, so such weapons would not be as threatening as in the existing regime in which NPB weapons could be legally tested in space.

oped and deployed. If they were developed and used without prior or complete testing, the improbability of their success compounded with the improbability of their attacking an operational satellite rather than a decoy (if such are deployed) would afford such satellites considerable protection and would, at least, disproportionately increase an enemy's cost for an effective ASAT capability. In addition, a ban on testing advanced ASAT weapons and deploying them in space would plausibly inhibit future competition in developing space-based weapons and would discourage development and covert testing and deployment of ASAT weapons of types which would pose the strongest incentives for preemptive ASAT attack. These benefits might be deemed advantageous by both the United States and the U.S.S.R.

As in the existing regime, the United States could retain a capability to attempt to negate low-altitude Soviet satellites (e.g., RORSAT) with its MV ASAT in the event of war and to respond in kind to a Soviet ASAT attack. However, confidence in the operational capability of this system might degrade over time without continued operational testing.

REGIME 4: A "ONE EACH/NO NEW TYPES" REGIME

Legal Regime

A "one each/no new types" regime might be established by adhering to agreements currently in force and further agreeing to ban the deployment in orbit of any weapon and the testing in space, "in an ASAT mode" of any system *except* the currently operational type of Soviet coorbital interceptor and the U.S. MV direct-ascent interceptor.⁹ Research on advanced systems and testing of these systems *on Earth* would not be prohibited.

⁹Although the U.S. Department of Defense has stated its belief that the Soviets have two ground-based lasers which could be used against satellites [U.S. Department of Defense, *Soviet Military Power*, 1984, p. 35], testing of such lasers as ASAT weapons would be prohibited. If these lasers had already been tested as ASATs by the time a "no new types agreement" could enter into force then this regime might have to be appropriately modified.

From the point of view of those interested in preserving the present agreement between the United States and the Soviet Union limiting ballistic missile defenses, another advantage of an ASAT test ban would be its prevention of tests of ASAT technologies with potential BMD applications.

On the other hand, from the point of view of those favoring intensive BMD research, a primary disadvantage of this regime, relative to the existing regime, is that the testing of some types of advanced BMD weapons might be prohibited. Such limitations could be slightly more restrictive than those of the ABM Treaty, and would be very restrictive compared to a regime in which the ABM Treaty was no longer in force [regime 7]. Finally, it must be recognized that a ban on testing ASAT capabilities and deploying space-based weapons would not offer absolute protection for satellites; there would remain some possibility that an untested or partially tested ASAT, if suddenly deployed and used, might actually work well enough to overcome passive countermeasures.

Offensive Posture

Offensive postures in a "no new types" regime would be as in an ASAT test ban and space-based weapon deployment ban regime (regime 3), except ASAT weapons of the single allowed type would almost surely be maintained for offensive ASAT missions in wartime.¹⁰ It is possible that each side would be satisfied with the capabilities such fully tested weapons could provide and would be less tempted than it would be in a test ban regime to covertly develop advanced ASAT weapons.

¹⁰It is possible, of course, that one or both nations would decide—as the United States did after ratifying the ABM Treaty—that its allowed system was not worth maintaining.

Defensive Posture

Passive countermeasures appropriate in a test-ban regime would also be appropriate in this regime, and for the same reasons. In addition, the unambiguous, if limited, threat posed by the one allowed ASAT weapon would provide an additional incentive to deploy passive countermeasures tailored to that weapon. For example, evasion might effectively counter coorbital interceptors such as those tested by the U.S.S.R., and maneuver—although not literally “evasion”—could complicate targeting of the U.S. MV. These countermeasures would probably be developed and employed even though they would not be effective against more capable weapons which might be developed but not tested nor deployed in space.

ECM and E-OCM would be allowed in this regime as in a test-ban/space-based weapon ban regime. Current U.S. and Soviet ASAT weapons would be insufficiently responsive to be effective for defensive shoot-back; however, they could be used in retaliation.

Net Assessment

The primary advantage of a “no new types” regime, relative to the existing regime, would be that critical U.S. satellites in higher orbits could be protected with some confidence from advanced ASAT weapons. If developed and used without prior testing, it is possible that such advanced ASAT weapons would not work properly. If they did work, it would not be clear that they could overcome the survivability measures that could be given satellites in this regime. More generally, a ban on testing advanced ASAT weapons would inhibit to some extent future arms competition in space.

Assuming the United States had successfully developed its MV ASAT, a “no new

types” regime might be particularly desirable. Such an agreement could prohibit the testing of Soviet ground-based lasers or MV-type ASAT weapons and limit them to their current, unsophisticated ASAT weapon. Of course, this would make such an agreement less acceptable to the Soviet Union. Should the Soviets test advanced ASAT weapons before such an agreement can enter into force, such an agreement would be less advantageous to the United States. However, since such an agreement might avert the risks posed by even more advanced—particularly directed-energy ASATs—a “no new types” agreement might still be considered valuable and negotiable by both the United States and the Soviet Union.

As in the existing regime, the United States could retain a capability to negate low-altitude Soviet satellites (e.g., RORSAT) in the event of war and to respond in kind to a Soviet ASAT attack. A primary disadvantage of a “no new types” regime, relative to the existing regime, would be that allowed U.S. ASAT capabilities would be inadequate to negate threatening Soviet satellites if such satellites were moved to higher orbits—a feasible but difficult and costly Soviet countermeasure. As in the test ban and space-based weapon ban regime, the testing of some types of advanced BMD weapons which would be allowed in the existing regime would be limited in this regime. Such limitations could be slightly more restrictive than those of the ABM Treaty and would be very restrictive compared to a regime in which the ABM Treaty was no longer in force.

Finally, it must be recognized that the reliability of protection afforded high-altitude satellites by a ban on testing “new types” would be uncertain; there would remain some probability that an untested advanced ASAT, if suddenly deployed and used, might actually work.

REGIME 5: RULES OF THE ROAD

Legal Regime

A legal regime providing for "keep-out zones" around satellites could be established by a "rules of the road" agreement similar to the "Rules of the Road at Sea" Treaty.¹¹ As discussed in chapter 6, such an agreement would not prohibit development, testing, or deployment in space of advanced ASAT weapons but would, instead, attempt to enhance security by establishing rules regarding space activities such as close approach of foreign satellites, advance notice of launch activities, high-velocity fly-bys, minimum separation distance between satellites, low-altitude overflight, and "keep-out zones."¹²

"Keep-out zones" would probably offer the closest thing to security in a "rules of the road" regime. The following "rules of the road" are illustrative of those which might be agreed should it be decided that "keep-out zones" are in the U.S. national security interest:

- Keep 100 kilometers and three degrees out-of-plane from foreign satellites below 5,000 km.
- Keep 500 km from foreign satellites above 5,000 km except those within 500 km of geosynchronous altitude.
- One pre-announced close approach at a time is allowed.
- In the event of a violation of the rules above, the nation of registry of the satellite which most recently initiated a maneuver "burn" is at fault and guilty of trespass.
- Satellites trespassing upon keep-out zones

¹¹16 UST 794, TIAS 5813.

¹²In addition to agreeing to such "rules of the road," the United States and the Soviet Union might have to modify their commitment to the 1967 Outer Space Treaty (18 U.S.T. 2410; T.I.A.S. 6347). Since Article II of the Outer Space Treaty states that "outer space . . . is not subject to national appropriation by claim of sovereignty, by means of use or occupation, or by any other means," this could be interpreted as prohibiting establishment of such keep-out zones. A contrary argument maintains that a precedent for "keep-out zones" can be found in the international acceptance of the principle that a satellite should not be placed in geostationary orbit if it will interfere with a satellite already in that orbit.

may be forcibly prevented from continued trespass.

The rationale for these rules is as follows:

- ASAT weapons such as nuclear interceptors would have to be kept at a range of several hundred kilometers from moderately hardened satellites in order to protect such satellites; advanced ASAT directed-energy weapons might have to be kept much farther away.¹³
- Satellites in geostationary orbit are already so closely spaced that a keep-out zone sufficiently large to protect satellites from nuclear attack could not be established around such satellites without displacing satellites already there and reducing the number of geostationary orbital slots available to other nations in the future.
- There are now very few satellites in supersynchronous orbits,¹⁴ but critical strategic warning and communications functions could be performed by satellites in such orbits. Should space systems be developed to operate in this region, there would be adequate room to accommodate large keep-out zones.
- There are presently few satellite orbits in deep space¹⁵ but below geosynchronous orbital altitude. The most notable exceptions are the orbits of various Soviet satellites in highly elliptical, semi-synchronous "Molniya-type" orbits, U.S. Air Force Satellite Data System (SDS) satellites in similar highly elliptical orbits, and U.S. (NAVSTAR) and Soviet (GLONASS) navigation satellites in semi-synchronous circular orbits. Although there are, or soon will be, many such satellites de-

¹³*In re*: NDEW, see, e.g., L.A. Wojcik, "Separation Requirements for Protection of High-Altitude Satellites from Coorbital Anti-Satellite Weapons," (Pittsburgh, Pa.: Carnegie-Mellon University, Department of Engineering and Public Policy, dissertation, March 1985); *in re*: NPB weapons, see ch. 4 of this report.

¹⁴I.e., higher than geosynchronous orbital altitude.

¹⁵I.e., higher than 3,000 nautical miles, or about 5,600 kilometers.

ployed, several satellites will (or could) occupy the same orbit. For example, 24 NAVSTAR satellites will occupy only three orbits, with eight satellites following one another around each of the three orbits. Hence there would be enough room in this region of space to accommodate keep-out zones of several hundred kilometers radius around the satellites presently deployed there.

- There are too many satellites in low-Earth orbit—particularly below the inner Van Allen radiation belt which extends from about 1,800 km (1,000 nmi) to about 5,600 km (3,000 nmi)—to accommodate keep-out zones of several hundred kilometers radius around the satellites presently deployed there. Indeed, many satellites have perigees within several hundred kilometers of the Earth's surface. Requiring keep-out zones of several hundred kilometers radius around low-altitude satellites would therefore be impractical.
- However, it would be feasible to establish smaller keep-out zones around satellites in low orbit and, in addition, to prohibit satellites from entering an orbital plane inclined less than, say, three degrees from the orbital plane of a foreign satellite at such altitudes. Specifying a minimum angular separation between orbital planes would prevent continuous trailing; for example, two satellites in 1,000 km circular orbits with orbital planes separated by three degrees would approach each other closely every 53 minutes, if properly "phased," but would separate by as much as about 400 km at intermediate times and would be separated by at least 200 km about half the time. If, in addition, such satellites were phased so as to not approach one another more closely than 100 km at any time, their separation would vary between 100 km and more than 400 km, at minimum. Under such rules, although satellites would occasionally approach one another so closely as to be mutually vulnerable to, for example, covert on-board nuclear weapons, such approaches would not all occur simultane-

ously. Therefore, adequately hardened, low-altitude satellites could not be instantly and simultaneously destroyed by relatively primitive ASAT weapons.

- There would be some value in allowing one pre-announced close approach at a time as an exception to the rules above. Such an exception would, for example, permit an inspection satellite carrying a gamma-ray spectrometer to trail a foreign satellite while trying to determine whether the foreign satellite carried fissionable material, possibly in violation of Article IV of the 1967 Outer Space Treaty. A disadvantage of such an exception would be that a trailing "inspection" satellite could carry a weapon and destroy the trailed satellite at close range. However, deployment of one on-orbit spare for any truly essential satellite would eliminate this risk.
- Although, given adequate space surveillance, it could be verified that two foreign satellites approached one another more closely than would be allowed by these rules, there could be a problem in determining which nation or other party would be guilty of a violation. It is difficult to predict, to within an accuracy of 100 km, where a satellite will be in several months as the result of an orbital transfer or stationkeeping maneuver. This is particularly true if the satellite is at very low altitude where it would be subject to atmospheric drag or at very high altitude where it would be subject to the lunar gravitational field. Hence, inadvertent close approach might be possible. Legal allocation of responsibilities in such a regime might follow precedents established in maritime and, especially, aeronautical law, which specifies minimum separation distances between aircraft and gives right-of-way to relatively unmaneuverable aircraft such as aerostats (balloons) and gliders. One possibility would be to give right-of-way to satellites already in orbit and, by implication, to assign fault to whichever spacecraft most recently initiated or continued a maneuver "burn."

The rules suggested above are intended to be illustrative rather than precise. Careful framing of an agreement would be required in order to prohibit unintended abuses such as establishment of a *de facto* barrier to deep space by deploying many small satellites in low orbit in order to fill an altitude band with keep-out zones. Rationing keep-out zones—e.g., 10 per nation—could solve this problem, but careful study may be required to foresee other possible abuses. In addition to its technical problems, this regime is likely to have a significant political dimensions inasmuch as it will affect the rights of all present and future spacefaring nations.

Offensive Posture

A “keep-out zone” agreement would not constrain offensive postures, and these could be as in the existing regime. The protection afforded by defended keep-out zones would diminish the effectiveness of some types of weapons such as coorbital interceptors and thereby diminish incentives to include them in a space order of battle. However, the effectiveness of advanced ASAT weapons—e.g., directed-energy weapons—would not be significantly reduced by keep-out zones of the size considered here.

Defensive Posture

A “keep-out zone” agreement would not constrain defensive postures, and these could be as in the existing regime. Decoys might be an attractive defensive measure in this regime, because “keep-out zones” would inhibit or preclude certain types of close inspection which

might otherwise be able to distinguish decoys from valuable satellites (see discussion in chapter 4). The deployment of DSATs or self-defense weapons would also be attractive, because such weapons could be used to enforce agreed keep-out zones. In the existing regime, attempts to enforce a declared keep-out zone by firing upon a “violating” suspected (but not proven) ASAT would probably be considered unlawful unless lethal capability and hostile intent of such spacecraft could be established.

Net Assessment

An agreement establishing minimum satellite separation rules could establish important legal rights to actively defend satellites, and would be an improvement over the existing regime if an active defense posture were desired. Enforcing agreed keep-out zones using DSATs would provide protection against relatively primitive ASAT weapons such as the current Soviet coorbital interceptor. However, keep-out zones large enough to protect satellites from advanced directed-energy weapons could be accommodated only beyond geosynchronous altitude.

A “keep-out zone” regime would have the advantage of not limiting research, development, and deployment of ASAT, DSAT, and BMD technologies. On the other hand, since a defended “keep-out zone” would provide significant protection against current ASAT weapons, it would encourage the development of more advanced systems. Such systems would likely increase in sophistication until the more advanced directed-energy technologies reduced the effectiveness of “keep-out zones.”

REGIME 6: SPACE SANCTUARIES

Legal Regime

A legal regime prohibiting the deployment of weapons in deep space (i.e., at altitudes greater than 3,000 nmi (5600 km)) or the testing of any weapons against instrumented targets or other objects in deep space could be established by a “Deep-Space Sanctuary.”

Such an agreement would be similar in some respects to the Antarctic Treaty,¹⁶ the Outer Space Treaty,¹⁷ the Treaty for the Prohibition

¹⁶The text of the Antarctic Treaty is reprinted in U.S. Arms Control and Disarmament Agency, *Arms Control and Disarmament Agreements* (Washington, D.C.: U.S. Government Printing Office, 1982), pp. 22-26.

¹⁷*Ibid.*, pp. 51-55.

of Nuclear Weapons in Latin America,¹⁸ the so-called Seabed Arms Control Treaty,¹⁹ and other treaties and agreements which establish demilitarized or de-weaponized zones. Such an agreement would not prohibit development, testing, or deployment in space of ASAT weapons but would attempt to enhance security by banning the testing and deployment of weapons in deep space where critical strategic satellites are presently based. At present, such systems are invulnerable to currently operational tested ASAT weapons.

In addition to such an agreement, other relevant agreements currently in force (Limited Test Ban Treaty, Outer Space Treaty, ABM Treaty) could remain in force in a "deep-space sanctuary" regime. Amendment of the Outer Space Treaty would not be an issue, since, unlike the "keep-out zone" regime, the "space sanctuary" regime could not be considered as a national appropriation of space.

Offensive Posture

Offensive postures appropriate in a "keep-out zones" regime [regime 5] would also be appropriate in a deep-space sanctuary regime, and for the same reasons. However, nuclear or kinetic-energy weapons—which would require more time to reach a satellite in deep space than to reach a satellite inside a small keep-out zone—would be less attractive as ASAT weapons than in a "keep-out zones" regime. Advanced directed-energy weapons, when feasible, would be the most capable ASAT weapons allowed in this regime, as in a "keep-out zones" regime.

Defensive Posture

Passive countermeasures appropriate in a "keep-out zone" regime would also be appropriate in this regime, and for the same reasons.

However, as in a "keep-out zone" regime, passive countermeasures could not economically protect large and expensive satellites as high as in geosynchronous orbit from advanced directed-energy weapons, which would be allowed in low orbit and which could be adequately tested against instrumented target satellites in low orbit. As in the existing regime, small, inexpensive satellites might be protected from such advanced weapons because they might cost more to attack than to build.

Active countermeasures appropriate in the existing regime would also be appropriate in this regime, and for the same reasons. As in the existing regime, attacking suspicious approaching ASAT weapons would be unlawful at low altitudes where such objects would have rights of innocent passage. Deployment in deep space of "shoot-back" capabilities or DSATs would probably be prohibited since it might be impossible to differentiate these weapons from offensive weapons.

Net Assessment

The primary advantage of this regime would be that it could protect satellites in high orbits from the current generation of ASAT weapons. In addition, a deep-space sanctuary regime would constrain ASAT development less than would a comprehensive test ban regime or a no-new-types regime. However, should the United States and the Soviet Union choose to pursue advanced ASAT weapons, a space sanctuary might offer only limited protection.

The greatest risks in a space sanctuary regime would be posed by advanced directed-energy weapons which could be tested and deployed at low altitudes. Such testing and deployment would probably be adequate to guarantee effectiveness against targets at higher altitudes. Satellites at very high, supersynchronous altitudes might still derive some protection from this regime, but violation of the sanctuary by highly maneuverable kinetic-energy weapons or by satellites covertly carrying powerful nuclear or directed-energy weapons would remain a risk.

¹⁸Ibid., pp. 64-75; the texts of Protocols I and II thereto are reprinted in *ibid.*, pp. 76 and 77, respectively.

¹⁹Formally titled "Treaty on the Prohibition of the Emplacement of Nuclear Weapons and Other Weapons of Mass Destruction on the Seabed and the Ocean Floor and in the Subsoil Thereof," the text of which is reprinted in *ibid.*, pp. 103-105.

REGIME 7: A SPACE-BASED BMD REGIME

Legal Regime

If the United States or the Soviet Union withdrew from the ABM Treaty, this would, in addition to allowing ballistic missile defense, eliminate constraints on ASAT capabilities now imposed by that Treaty. The resulting regime would allow both advanced ASAT and space-based BMD weapons. Withdrawal from the Limited Test Ban Treaty and the Outer Space Treaty would also be necessary if the United States or the Soviet Union desired to test and deploy space weapons that used nuclear explosives as a power source.

Offensive Posture

In a space-based BMD regime, ASAT options would be less constrained than in the existing regime and advanced ASAT weapons would be more essential for defeating space-based enemy BMD system. In such a regime, advanced space-based weapons could be deployed at low altitudes and used as ASAT or DSAT weapons as well as for BMD. Some space-based weapons which would be useful—but not preferred—for satellite negation might be deployed in this regime because of their usefulness as BMD weapons. For example, kinetic-energy weapons and continuous-wave lasers which could destroy fast-burn boosters deep within the atmosphere might be preferred as BMD weapons over neutral particle beam or X-ray laser directed-energy weapons. The latter, although more useful in an ASAT role, could not readily penetrate the atmosphere and therefore may have more limited value as BMD weapons.

Defensive Posture

In a space-based BMD regime, defensive measures would be less constrained and more essential than in the existing regime. Advanced space-based weapons could be deployed at low altitudes and then used as ASAT or DSAT weapons. In a DSAT role, these weapons could offer some protection to low-altitude satellites. However, such satel-

lites would probably remain vulnerable to attack by larger weapons or by expendable single-shot weapons (e.g., single-pulse lasers) which could attack from great range unless held at bay by large "keep-out zones." As discussed in chapter 4, it is possible that future technological advances might allow decoys to be developed that were cost-effective when compared to future offensive weapons and discrimination capabilities.

In evaluating offensive and defensive postures in a space-based BMD regime, it is necessary to assume that future technology will confer an advantage to ASAT countermeasures vis-a-vis ASAT capabilities. Although such an assumption may be unjustified at present, if the United States is to deploy advanced space-based BMD weapons then it must also have developed highly effective countermeasures to ASAT weapons. It would be irrational for the United States to seek to establish a "space-based BMD" regime unless it judged that adequate numbers of the space-based BMD components would survive or unless it judged that non-space-based BMD components could provide an adequate defense without space-based components. Scenarios illustrating each of these conditions are imaginable; for example:

1. The United States may judge that BMD systems with space-based components *could not be destroyed* by the U.S.S.R.: For example, the United States might deploy, in addition to ground-based BMD components, space-based electromagnetic launchers for kinetic-energy weapons and defend them by hardening, deception, and shoot-back. Deceptive measures employed might include massive decoys made from asteroidal material such as nickel.²⁰ While

²⁰It is speculated that the cost of transporting such material to low Earth orbit and refining and fabricating finished products with it there may eventually be several orders of magnitude lower than the cost of refining and forming such materials on Earth and transporting the products to space. Should this forecast prove accurate, deception may have a favorable cost-exchange ratio even against ASAT systems which can discriminate decoys on the basis of mass density.

the Soviets might be able to destroy some BMD components, the system as a whole would survive.

2. The United States may judge that space-based BMD components *would not be destroyed* by the U.S.S.R.: Even if future technology does not favor ASAT countermeasures to the extent assumed in (1), ASAT countermeasure technology could be so effective that the Soviet leadership would be unwilling to pay the costs of defeating the countermeasures.
3. The United States may desire an extensive BMD system *without space-based components*: For example, U.S. aspiration might be limited to defense of hardened facilities which house strategic retaliatory forces or command and control systems; this might be accomplished using ground-based radars and interceptors but would require deployment of more of these over larger areas than is allowed by the ABM Treaty. Alternatively, the United States might desire an extensive BMD system capable of defending industry and population using only ground-based weapons.

Net Assessment

Depending on one's viewpoint, the principal advantage, or disadvantage, of a space-based BMD regime would be that it would allow the United States and the Soviet Union to deploy highly capable weapons in space. Since even a limited BMD system would probably make a very good ASAT system decision to proceed with BMD deployment necessarily includes a decision not to proceed with certain types of ASAT arms control.²¹

On March 23, 1983, the President called for a vigorous research program to determine the

feasibility of highly effective, advanced-technology BMD systems, suggesting that the deployment of such systems, if feasible, would be desirable. Before the United States deployed space-based BMD systems it would have to determine, first, that the contribution that such systems made to U.S. security was great enough to compensate for the threat which similar opposing systems would pose to U.S. satellites, and second, that space-based BMD components could be protected at competitive cost against advanced ASAT weapons.

The threat to satellites would be greater in a space-based BMD regime than in any other regime because the BMD weapons would likely have extensive ASAT capabilities. The expense of equipping all military satellites with countermeasures against such capabilities would be considerable, particularly if, as some fear, deployment of space-based BMD systems will lead to a major arms race in both offensive and defensive weapons. However, if, as some argue, space-based missile defenses can make us more secure and encourage the Soviets to make real reductions in offensive missiles, this would reduce the threat of U.S./Soviet conflict and to contribute to a mutual desire to protect space assets. In a world where conflict was less likely, satellite vulnerability would be less important.

ASAT countermeasures must prove to be effective for space-based BMD platforms if a decision to deploy them is to make sense. It is possible that large improvements in the effectiveness or economy of passive countermeasures such as combinations of hardening, deception, and proliferation might provide the needed protection. If such improvements occur, they might also be used effectively for satellites in the other regimes discussed above. Alternatively, the superior fire-power or massive shielding of BMD weapons might give them a degree of protection unattainable by smaller, less capable satellites.

²¹It is possible that in a space-based BMD regime one might also wish to negotiate "rules of the road" such as "keep-out zones," or perhaps even a deep-space sanctuary.

Appendix A

**Soviet Draft Treaty on the
Prohibition of the Use of Force
in Outer Space and From Space
Against the Earth**

Preceding Page Blank

Soviet Draft Treaty on the Prohibition of the Use of Force in Outer Space and From Space Against the Earth

U.N. General Assembly document A/38/194, Aug. 22, 1983

The States Parties to this Treaty,
Guided by the principle whereby Members of the United Nations shall refrain in their international relations from the threat or use of force in any manner inconsistent with the purposes of the United Nations,

Seeking to avert an arms race in outer space and thus to lessen the danger to mankind of the threat of nuclear war,

Desiring to contribute towards attainment of the goal whereby the exploration and utilization of outer space, including the Moon and other celestial bodies, would be carried out exclusively for peaceful purposes,

Have agreed on the following:

Article 1

It is prohibited to resort to the use or threat of force in outer space and the atmosphere and on the Earth through the utilization, as instruments of destruction, of space objects in orbit around the Earth, on celestial bodies or stationed in space in any other manner.

It is further prohibited to resort to the use or threat of force against space objects in orbit around the Earth, on celestial bodies or stationed in outer space in any other manner.

Article 2

In accordance with the provisions of article 1, States Parties to this Treaty undertake:

1. Not to test or deploy by placing in orbit around the Earth or stationing on celestial bodies or in any other manner any space-based weapons for the destruction of objects on the Earth, in the atmosphere or in outer space.
2. Not to utilize space objects in orbit around the Earth, on celestial bodies or stationed in outer space in any other manner as means to de-

stroy any targets on the Earth, in the atmosphere or in outer space.

3. Not to destroy, damage, disturb the normal functioning or change the flight trajectory of space objects of other States.
4. Not to test or create new anti-satellite systems and to destroy any anti-satellite systems that they may already have.
5. Not to test or use manned spacecraft for military, including anti-satellite, purposes.

Article 3

The State Parties to this Treaty agree not to assist, encourage or induce any State, group of States, international organization or natural or legal person to engage in activities prohibited by this Treaty.

Article 4

1. For the purposes of providing assurance of compliance with the provisions of this Treaty, each State Party shall use the national technical means of verification at its disposal in a manner consistent with generally recognized principles of international law.
2. Each State Party undertakes not to interfere with the national technical means of verification of other States Parties operating in accordance with paragraph 1 of this article.

Article 5

1. The States Parties to this Treaty undertake to consult and co-operate with each other in solving any problems that may arise in connection with the objectives of the Treaty or its implementation.
2. Consultations and co-operation as provided in paragraph 1 of this article may also be undertaken by having recourse to appropriate in-

ternational procedures within the United Nations and in accordance with its Charter. Such recourse may include utilization of the services of the Consultative Committee of States Parties to the Treaty.

3. The Consultative Committee of States Parties to the Treaty shall be convened by the depositary within one month after the receipt of a request from any State Party to this Treaty. Any State Party may nominate a representative to serve on the Committee.

Article 6

Each State Party to this Treaty undertakes to adopt such internal measures as it may deem necessary to fulfil its constitutional requirements in order to prohibit or prevent the carrying out of any activity contrary to the provisions of this Treaty in any place whatever under its jurisdiction or control.

Article 7

Nothing in this Treaty shall affect the rights and obligations of States under the Charter of the United Nations.

Article 8

Any dispute which may arise in connection with the implementation of this Treaty shall be settled exclusively by peaceful means through recourse to the procedures provided for in the Charter of the United Nations.

Article 9

This Treaty shall be of unlimited duration.

Article 10

1. This Treaty shall be open to all States for signature at United Nations Headquarters in New York. Any State which does not sign this treaty before its entry into force in accordance with paragraph 3 of this article may accede to it at any time.
2. This Treaty shall be subject to ratification by signatory States. Instruments of ratification and accession shall be deposited with the Secretary-General of the United Nations.
3. This Treaty shall enter into force between the States which have deposited instruments of ratification upon the deposit with the Secretary-General of the United Nations of the fifth instrument of ratification, provided that such instruments have been deposited by the Union of Soviet Socialist Republics and the United States of America.
4. For States whose instruments of ratification or accession are deposited after the entry into force of this Treaty, it shall enter into force on the date of the deposit of their instruments of ratification or accession.
5. The Secretary-General of the United Nations shall promptly inform all signatory and acceding States of the date of each signature, the date of deposit of each instrument of ratification or accession, the date of entry into force of this Treaty as well as other notices.

Article 11

This Treaty, of which the Arabic, Chinese, English, French, Russian and Spanish texts are equally authentic, shall be deposited with the Secretary-General of the United Nations, who shall send duly certified copies thereof to the Governments of the signatory and acceding States.



Office of Technology Assessment

The Office of Technology Assessment (OTA) was created in 1972 as an analytical arm of Congress. OTA's basic function is to help legislative policymakers anticipate and plan for the consequences of technological changes and to examine the many ways, expected and unexpected, in which technology affects people's lives. The assessment of technology calls for exploration of the physical, biological, economic, social, and political impacts that can result from applications of scientific knowledge. OTA provides Congress with independent and timely information about the potential effects—both beneficial and harmful—of technological applications.

Requests for studies are made by chairmen of standing committees of the House of Representatives or Senate; by the Technology Assessment Board, the governing body of OTA; or by the Director of OTA in consultation with the Board.

The Technology Assessment Board is composed of six members of the House, six members of the Senate, and the OTA Director, who is a nonvoting member.

OTA has studies under way in nine program areas: energy and materials; industry, technology, and employment; international security and commerce; biological applications; food and renewable resources; health; communication and information technologies; oceans and environment; and science, transportation, and innovation.
