

**COMMAND, CONTROL,
COMMUNICATIONS, COMPUTERS,
INTELLIGENCE & ELECTRONIC
WARFARE AND SENSORS AND
INFORMATION MANAGEMENT
(C4IEWS&IM)**

PROJECT BOOK

FISCAL YEAR 1998



DTIC QUALITY INSPECTED 2

19980219 148

APPROVED FOR PUBLIC RELEASE; DISTRIBUTION IS UNLIMITED.

**HEADQUARTERS, US ARMY COMMUNICATIONS-ELECTRONICS COMMAND
FORT MONMOUTH, NEW JERSEY 07703-5027**



**US ARMY
COMMUNICATIONS-
ELECTRONICS COMMAND**

CECOM BOTTOM LINE: THE SOLDIER

NOTICES

Disclaimer

The findings in this report are not to be construed as an official Department of the Army position, unless so designated by other authorized documents.

The citation of trade names and names of manufacturers in this report is not to be construed as official Government indorsement or approval of commercial products or services referenced herein.

**C4IEWS & IM
PROJECT BOOK
FISCAL YEAR 1998**

**Message from the Commanding General
US Army Communications-Electronics Command (CECOM)
and Fort Monmouth, New Jersey**

Dear Reader:

I am pleased to present the Fiscal Year 1998 Command, Control, Communications, Computers, Intelligence, Electronic Warfare, Sensors and Information Management (C4IEWS&IM) Project Book. It displays a cross section of the Army Team's systems and equipment which are currently in development, production, or in the field. This publication reflects a coordinated effort between CECOM, PEO Command, Control and Communications Systems (PEO C3S), PEO Intelligence and Electronic Warfare & Sensors (PEO IEW&S), and PEO Standard Army Management Information Systems (STAMIS).

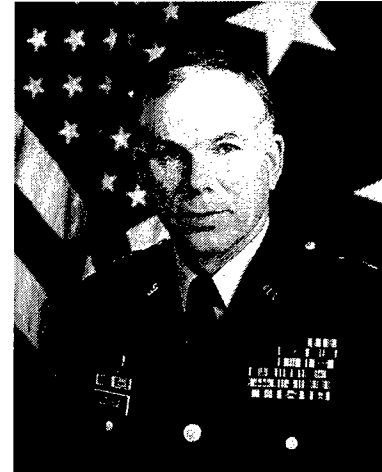

The C4IEWS&IM military community shares the critical mission of equipping, sustaining, and modernizing technologically superior and integrated C4IEWS&IM systems. This mission supports the nation's warfighters in the accomplishment of dominant maneuver, precision engagement, full dimensional protection and focused logistics through information superiority.

We must take the lead in meeting future challenges as we experience vast changes to our global environment and resources. The C4IEWS&IM Project Book serves to keep our audience abreast of our latest developments and initiatives toward this objective.

For your convenience, the C4IEWS&IM Project Book continues to be on the Worldwide Web site: www.monmouth.army.mil.

CECOM Bottom Line: THE SOLDIER.

Sincerely,

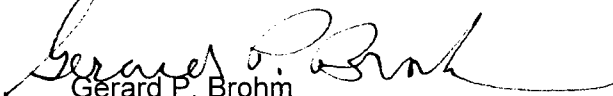
Gerard P. Brohm
Major General, US Army
Commanding

The Fiscal Year 1998 edition of the C4IEWS&IM Project Book is presented in two formats. One is for use by DOD components only (critical technologies) and is For Official Use Only (FOUO). A second version is available for use by DOD components and their contractors and is available to the public.

The information found within is current at the time of publication (January 1998) and is subject to change. Requests for the FOUO version or comments/suggestions may be addressed as follows:

Commander
U.S. Army Communications-Electronics Command (CECOM)
ATTN: AMSEL-PE-PD (Jim Stojka)
Fort Monmouth, New Jersey 07703-5027

DSN: 992-8730 Commercial: (732) 532-8730
E-Mail: AMSEL-PE-PD@DOIM6.MONMOUTH-EMH3.ARMY.MIL

Send requests for the non-FOUO version to:

Commander
U.S. Army Communications-Electronics Command (CECOM)
ATTN: AMSEL-AC-SP-BL
Fort Monmouth, New Jersey 07703-5027

DSN: 992-2681 Commercial: (732) 532-2681
FAX: 992-9095 Commercial: (732) 532-9095

INDEX OF ORGANIZATIONS

<u>ORGANIZATION</u>	<u>SECTION</u>
<i>PEO COMMAND, CONTROL & COMMUNICATIONS SYSTEMS (PEO C3S)</i>	1-11
PM, AIR DEFENSE COMMAND AND CONTROL SYSTEMS (PM, ADCCS)	1
PM, APPLIQUE	2
PM, ARMY TACTICAL COMMAND & CONTROL SYSTEMS (PM, ATCCS)	3
PD, COUNTERNARCOTICS COMMAND & MANAGEMENT SYSTEM (PD, CNCMS)	4
PM, FIELD ARTILLERY TACTICAL DATA SYSTEMS (PM, FATDS)	5
PM, INTELLIGENCE FUSION	6
PM, MILITARY SATELLITE COMMUNICATIONS (PM, MILSATCOM)	7
PM, STRATEGIC & THEATER COMMAND & CONTROL SYSTEMS (PM, STCCS)	8
PM, TACTICAL RADIO COMMUNICATIONS SYSTEMS (PM, TRCS)	9
PM, WARFIGHTER INFORMATION NETWORK-TERRESTRIAL (WIN-T)	10
PD, COMBAT TERRAIN INFORMATION SYSTEM (PD, CTIS)	11
<i>PEO INTELLIGENCE, ELECTRONIC WARFARE & SENSORS (PEO IEW&S)</i>	12-17
PM, COMBAT IDENTIFICATION (PM, COMBAT ID)	12
PM, JOINT SURVEILLANCE TARGET ATTACK RADAR SYSTEM (PM, JSTARS)	13
PM, NIGHT VISION/RECON SURVEILLANCE & TARGET ACQUISITION (PM, NV/RSTA)	14
PM, SENTINEL	15
PM, SIGNALS WARFARE (PM, SW)	16
PO, JOINT PRECISION STRIKE DEMONSTRATION (PO, JPSD)	17
<i>PEO STANDARD ARMY MANAGEMENT INFORMATION SYSTEMS (STAMIS)</i>	18

INDEX OF ORGANIZATIONS

<u>ORGANIZATION</u>	<u>SECTION</u>
COMMUNICATIONS-ELECTRONICS COMMAND (CECOM)	19-34
<i>LOGISTICS AND READINESS CENTER (LRC)</i>	19-22
COMMAND, CONTROL SYS/AVIONICS DIRECTORATE (CCS/AVIONICS)	19
CECOM COMMUNICATIONS SECURITY LOGISTICS ACTIVITY (CCSLA)	20
COMMUNICATIONS DIRECTORATE	21
INTELLIGENCE ELECTRONIC WARFARE & SENSORS DIRECTORATE (IEWS)	22
<i>RESEARCH, DEVELOPMENT & ENGINEERING CENTER (RDEC)</i>	23-26
C2 AND SYSTEMS INTEGRATION DIRECTORATE (C2SID)	23
INTELLIGENCE AND INFORMATION WARFARE DIRECTORATE (I2WD)	24
NIGHT VISION & ELECTRONIC SENSORS DIRECTORATE (NVESD)	25
SPACE AND TERRESTRIAL COMMUNICATION DIRECTORATE (S&TCD)	26
<i>SOFTWARE ENGINEERING CENTER (SEC)</i>	27
<i>SYSTEMS MANAGEMENT CENTER (SMC)</i>	28-34
SMC	28
PM, SMALL COMPUTER PROGRAM (SCP)	29
PM, DEFENSE COMMUNICATIONS AND ARMY SWITCHED SYSTEMS (PM, DCASS)	30
PM, DEFENSE COMMUNICATIONS AND ARMY TRANSMISSION SYSTEMS (PM, DCATS)	31
PM, FIREFINDER	32
PM, GLOBAL POSITIONING SYSTEM (PM, GPS)	33
PM, MOBILE ELECTRIC POWER (PM, MEP)	34

TABLE OF CONTENTS

<u>ORGANIZATION</u>	<u>SYSTEM / EQUIPMENT</u>	<u>PAGE</u>
 PEO C3S		
 <i>PM, ADCCS</i>		
	AN/TSQ-73, MOD TO INTEGRATE PATRIOT, HAWK, KSA WEAPON SYSTEMS	1-1
	AIR AND MISSILE DEFENSE COMMAND/FORCE PROJECTION TOC	1-2
	AIR AND MISSILE DEFENSE PLANNING AND CONTROL SYSTEM (AMDPCS)	1-3
	AIR AND MISSILE DEFENSE WORKSTATION (AMDWS)	1-4
	AIR DEFENSE ARTILLERY BRIGADE TACTICAL OPERATIONS CENTER	1-5
	ADTOC COMM PROCESSOR	1-6
	ANNEX C EXTENDED AIR DEFENSE (EAD) COMMON INTEROPERABILITY PROGRAM	1-7
	ARMY TACTICAL OPERATIONS CENTER (TOC)	1-8
	COMMANDER-IN-CHIEF THEATER MISSILE DEFENSE (CINC TMD)	1-9
	FORWARD AREA AIR DEFENSE, COMMAND, CONTROL & INTELL (FAADC2I)	1-10
	III CORPS ARTILLERY ASSAULT COMMAND POST/MAIN COMMAND POST	1-11
	US 3RD ARMY " LUCKY MAIN" TACTICAL OPERATIONS CENTER (TOC)	1-12
	TASK FORCE/DIVISION XXI TACTICAL OPERATIONS CENTERS (TF/DIV XXI TOC)	1-13
 <i>PM, APPLIQUE</i>		
		2-1
 <i>PM, ATCCS</i>		
	COMMAND AND CONTROL VEHICLE (C2V) MISSION MODULE SYSTEM (MMS)	3-1
	COMMON HARDWARE SYSTEMS (CHS)	3-2
	COMMON SOFTWARE SYSTEMS	3-3
	MANEUVER CONTROL SYSTEM (MCS)	3-4
	STANDARD INTEGRATED COMMAND POST SYSTEM (SICPS)	3-5
 <i>PD, CNCMS</i>		
	COUNTERNARCOTICS COMMAND & MANAGEMENT SYSTEM (CNCMS)	4-1
 <i>PM, FATDS</i>		
	ADVANCED FIELD ARTILLERY TACTICAL DATA SYSTEM (AFATDS)	5-1
	FIRE SUPPORT ADA CONVERSION (FSAC)	5-2
	FORWARD ENTRY DEVICE (FED)	5-3
	INITIAL FIRE SUPPORT AUTOMATED SYSTEM (IFSAS)	5-4
	LIGHTWEIGHT FORWARD ENTRY DEVICE (LFED)	5-5
 <i>PM, INTELLIGENCE FUSION</i>		
	PM, INTELLIGENCE FUSION	6-1
	ALL SOURCE ANALYSIS SYSTEM (ASAS)	6-2
	CI/HUMINT MANAGEMENT SYSTEMS (CHIMS)	6-3
	INTEGRATED METEOROLOGICAL SYSTEM (IMETS), AN/TMQ-40	6-4
	JOINT COLLECTION MANAGEMENT TOOLS (JCMT)	6-5
 <i>PM, MILSATCOM</i>		
	AN/FRC-181V1, AN/TRC-194V1/2, MILSTAR GROUND CMD POST (GNDCP) TERMINALS	7-1
	AN/PSC-5, " SPITFIRE" ULTRA HIGH FREQUENCY DAMA TERMINAL	7-2
	FLYAWAY TRI-BAND SATELLITE TERMINAL (FTSAT) AN/USC-60	7-3
	GLOBAL BROADCAST SERVICE (GBS)	7-4
	LIGHTWEIGHT HIGH GAIN X-BAND ANTENNA (LHGXA)	7-5
	LIGHT MULTIBAND SATELLITE TERMINAL (LMST)	7-6

TABLE OF CONTENTS

<u>ORGANIZATION</u>	<u>SYSTEM / EQUIPMENT</u>	<u>PAGE</u>
PEO C3S (Cont'd)		
<i>PM, MILSATCOM</i>		
	LIGHTWEIGHT SATELLITE TERMINAL UPGRADE (LST8000(V)T)	7-7
	SECURE MOBILE ANTI-JAM RELIABLE TACTICAL TERMINAL (SMART-T)	7-8
	SINGLE CHANNEL ANTI-JAM MANPORTABLE TERMINAL (SCAMP) BLOCK I	7-9
	SINGLE CHANNEL ANTI-JAM MANPORTABLE TERMINAL (SCAMP BLOCK II)	7-10
	SPECIAL OPERATIONS FORCES TACTICAL ASSURED CONNECTIVITY SYSTEM (SOFTACS)	7-11
	SUPER HIGH FREQUENCY TRI-BAND ADVANCED RANGE EXT TERM. (STAR-T)	7-12
<i>PM, STCCS</i>		
	COMBAT SERVICE SUPPORT CONTROL SYSTEM (CSSCS)	8-1
	STANDARD THEATER ARMY COMMAND & CONTROL SYSTEM (STACCS)	8-2
<i>PM, TRCS</i>		
	AN/TSQ-129, POSITION LOCATION REPORTING SYSTEM (PLRS)	9-1
	ENHANCED POSITION LOCATION REPORTING SYSTEM (EPLRS)	9-2
	JOINT TACTICAL INFORMATION DISTRIBUTION SYSTEM (JTIDS)	9-3
	SINGLE CHANNEL GROUND & AIRBORNE RADIO SYSTEM (SINGARS)	9-4
	TD-1456/VRC, FREQUENCY HOPPING MULTIPLEXER (FHMUX)	9-5
<i>PM, WIN-T</i>		
	AN/TRC-138A, 138B, 138C, RADIO REPEATER SETS	10-1
	AN/TRC-173()	10-2
	AN/TRC-174(), RADIO REPEATER SET	10-3
	AN/TRC-175()	10-4
	AN/TTC-39, 39A, 39D, CIRCUIT SWITCH	10-5
	AN/TYQ-30V1,V2, TYQ-31, COMMUNICATION SYS CONTROL ELEMENT (CSCE)	10-6
	ARMY KEY MANAGEMENT SYSTEM (AKMS)	10-7
	ASYNCHRONOUS TRANSFER MODE (ATM)	10-8
	DOWN SIZED CSCE (D/S COMM SYSTEMS CONTROL ELEMENT) (ISYSCON-EAC)	10-9
	DIGITAL GROUP MULTIPLEXER ANTENNA MAST PROGRAM (DAMP)	10-10
	INTEGRATED SYSTEMS CONTROL (ISYSCON)	10-11
	MOBILE SUBSCRIBER EQUIPMENT (MSE)	10-12
	NETWORK ENCRYPTION SYSTEMS (NES)	10-13
	NETWORK MANAGEMENT TOOL (NMT)	10-14
	ON-422, COMPACT DIGITAL SWITCH	10-15
	SWITCH MULTIPLEX UNIT (SMU)	10-16
	WARFIGHTER INFORMATION NETWORK (WIN) - TERRESTRIAL TRANSPORT (TT)	10-17
<i>PD, CTIS</i>		
	DIGITAL TOPOGRAPHIC SUPPORT SYSTEM (DTSS) AN/TYQ-48	11-1
	DIGITAL TOPOGRAPHIC SUPPORT SYSTEM/QUICK RESPONSE MULTICOLOR PRINTER (DTSS/QRMP) AN/TYQ-67(V)1	11-2

TABLE OF CONTENTS

<u>ORGANIZATION</u>	<u>SYSTEM / EQUIPMENT</u>	<u>PAGE</u>
 PEO IEW&S		
 <i>PM, COMBAT ID</i>		
	BATTLEFIELD COMBAT IDENTIFICATION SYSTEM (BCIS)	12-1
	COMBAT IDENTIFICATION ADVANCED TECHNOLOGY DEMONSTRATION	12-2
	COMBAT IDENTIFICATION DISMOUNTED SOLDIER	12-3
 <i>PM, JSTARS</i>		
	JOINT TACTICAL TERMINAL (JTT)	13-1
	JOINT STARS GROUND STATION MODULE/COMMON GROUND STATION (JSTARS)	13-2
 <i>PM, NV/RSTA</i>		
	AN/AVS-6, AVIATION NIGHT VISION IMAGING SYSTEM (ANVIS)	14-1
	AN/AVS-7, ANVIS/HEADS UP DISPLAY (ANVIS/HUD)	14-2
	AN/PAS-13, THERMAL WEAPON SIGHT (TWS)	14-3
	AN/PVS-7D NIGHT VISION GOGGLES	14-4
	AN/PVS-10, SNIPER NIGHT SIGHT (SNS)	14-5
	AN/PVS-14 MONOCULAR NIGHT VISION DEVICE (MNVD)	14-6
	AN/PLQ-8 TARGET LOCATION & OBSERVATIONS SYSTEM (TLOS)	14-7
	AN/VAS-5 DRIVER'S VISION ENHANCER (DVE)	14-8
	HORIZONTAL TECHNOLOGY INTEGRATION SECOND GENERATION FLIR (HTI SGF)	14-9
	LIGHTWEIGHT LASER DESIGNATOR RANGE FINDER (LLDR)	14-10
	LIGHTWEIGHT VIDEO RECONNAISSANCE SYSTEM (LVRS)AN/PVH- (1&2)	14-11
	LONG RANGE ADVANCED SCOUT SURVEILLANCE SYSTEM (LRAS3)	14-12
	SAR TARGET RECOGNITION & LOCATION SYSTEM (STARLOS)	14-13
	TACTICAL ENHANCED SYNTHETIC APERTURE RADAR (TESAR)	14-14
 <i>PM, SENTINEL</i>		
	SENTINEL	15-1
 <i>PM, SW</i>		
	ADVANCED QUICKFIX (AQF)	16-1
	AIRBORNE RECONNAISSANCE LOW (ARL)	16-2
	AN/MLQ-38, GROUND BASED COMMON SENSOR HEAVY (GBCS-H)	16-3
	AN/MLQ-39, GROUND BASED COMMON SENSOR LIGHT (GBCS-L)	16-4
	AN/USD-9C, GUARDRAIL/COMMON SENSOR (GR/CS)	16-5
	COMMON MODULAR ELINT SYSTEM (CMES)	16-6
	COMMUNICATIONS HIGH ACCURACY LOCATION SUBSYSTEM EXPLOITABLE (CHALS-X)	16-7
	TACJAM-A	16-8
 <i>PO, JPSD</i>		
	PRECISION/RAPID COUNTER-MRL ACTD	17-1
	RAPID BATTLEFIELD VISUALIZATION ACTD	17-2

TABLE OF CONTENTS

<u>ORGANIZATION</u>	<u>SYSTEM / EQUIPMENT</u>	<u>PAGE</u>
PEO STAMIS		
	ARMY DISTANCE LEARNING PROGRAM (ADLP)	18-1
	DEFENSE MESSAGE SYSTEM-ARMY (DMS-A)	18-2
	JOINT COMPUTER-AIDED ACQUISITION AND LOGISTICS SUPPORT (JCALS)	18-3
	JOINT RECRUITING INFORMATION SUPPORT SYSTEM (JRISS)	18-4
	SUSTAINING BASE AUTOMATION (SBA)	18-5
	STANDARD INSTALLATION/DIVISION PERSONNEL SYSTEM-3 (SIDPERS-3)	18-6
	TRANSPORTATION COORDINATOR-AUTOMATED INFO FOR THE MOVEMENT SYS II	18-7
	INTEGRATED LOGISTICS SYSTEMS (ILOGS)	18-8
	DA MOVEMENTS MANAGEMENT SYSTEMS-REDESIGN (DAMMS-R)	18-9
	INTEGRATED COMBAT SERVICE SUPPORT SYSTEM (ICS3)	18-10
	STANDARD ARMY AMMUNITION SYSTEM (SAAS)	18-11
	STANDARD ARMY MAINTENANCE SYSTEM (SAMS)	18-12
	STANDARD ARMY RETAIL SUPPLY SYSTEM (SARSS)	18-13
	UNIT LEVEL LOGISTICS SYSTEM (ULLS)	18-14
	TACTICAL MANAGEMENT INFORMATION SYSTEMS (TACMIS)	18-15
	AUTOMATED IDENTIFICATION TECHNOLOGY (AIT)	18-16
	CORPS THEATRE ADP SERVICE CENTER, PHASE II (CTASC-II)	18-17
	PERSONNEL ELECTRONIC RECORD MANAGEMENT SYSTEMS (PERMS)	18-18
	STAMIS TACTICAL COMPUTERS (STACOMP)	18-19

TABLE OF CONTENTS

<u>ORGANIZATION</u>	<u>SYSTEM / EQUIPMENT</u>	<u>PAGE</u>
CECOM		
LRC		
CCS/AVIONICS		
	AN/ARC-164V, HAVE QUICK II (HQ II)	19-1
	AN/ARC-220 AND VRC-100 HIGH FREQUENCY RADIO	19-2
	AN/ASC-15B/C, COMMUNICATIONS CENTRAL-CONSOLE	19-3
	AN/ASN-128B DOPPLER GPS	19-4
	AN/AYD-1, PERSONNEL LOCATOR SYSTEM	19-5
	AN/FSC-92, AIR TRAFFIC CONTROL COMMUNICATIONS SWITCHING SYS (ATCCSS)	19-6
	AN/GRC-240, HAVE QUICK II (HQ II) GROUND RADIO	19-7
	AN/GSG-10, TACFIRE	19-8
	AN/GYK-29, BATTERY COMPUTER SYSTEM (BCS)	19-9
	AN/MYQ-4A, DECENTRALIZED AUTO SERVICE SPT SYS (DIV/CORPS) DAS-3 (D/C)	19-10
	AN/TSW-7A, AIR TRAFFIC CONTROL CENTRAL (ATCC)	19-11
	AN/USM-410, ELECTRONIC QUALITY ASSURANCE TEST EQUIPMENT (EQUATE)	19-12
	AN/UYQ-43 (V) 1&2, TACTICAL COMPUTER PROC; ANALYST CONS; MCS	19-13
	CORPS/THEATER ADP SERVICE CENTER I (CTASC-I)	19-14
	CORPS/THEATER ADP SERVICE CENTER II (CTASC-II)	19-15
	FORWARD ENTRY DEVICE (FED)	19-16
	LARGE-SCALE TACTICAL DOCUMENT COPIER	19-17
	LIGHTWEIGHT TACTICAL FIRE DIRECTION SYSTEM (LTACFIRE)	19-18
	TACTICAL ARMY COMBAT SERVICE SUPPORT COMPUTER SYSTEM (TACCS)	19-19
	INTERFACE UNIT, AUTOMATIC DATA PROCESSING, CA-67A/U, TACTICAL TERMINAL ADAPTER (TTA)	19-20
CCSLA		
	THIS SECTION IS NOT AVAILABLE IN THE NON-FOUO FORMAT	
COMMUNICATIONS DIRECTORATE		
	AB-1309/TRC, MAST	21-1
	AB-1386/U, QUICK ERECT ANTENNA MAST (QEAM)	21-2
	AN/GRC-193, IMPROVED HIGH FREQUENCY RADIO SET	21-3
	AN/GRC-213, IMPROVED HIGH FREQUENCY RADIO SET	21-4
	AN/GRC-222, RADIO SET	21-5
	AN/PRC-104, IMPROVED HIGH FREQUENCY RADIO SET	21-6
	AN/PRC-126, RADIO SET	21-7
	AN/PRC-127, RADIO SET	21-8
	AN/PSC-3, VSC-7, SINGLE CHANNEL UHF SATCOM TACTICAL TERMINALS	21-9
	AN/TRC-170V2, V3 TROPOSCATTER RADIO TERMINAL (TROPO)	21-10
	AN/TSC-85B, 93B, TACTICAL SATELLITE COMMUNICATIONS TERMINALS	21-11
	AN/TSC-94A, 100A, MULTICHANNEL SUPER HIGH FREQ SATCOM TERMINALS	21-12
	AN/TSC-128, LONG RANGE SURVEILLANCE UNIT-BASE RADIO STATION (LRSU-BRS)	21-13
	AN/TTC-41V, CENTRAL OFFICE, TELEPHONE, AUTOMATIC	21-14
	AN/UGC-144, COMMUNICATIONS TERMINAL	21-15
	AN/USC-43V2, ADV NARROWBAND DIGITAL VOICE TERMINAL (ANDVT) TACT TERMINAL	21-16
	AN/UXC-7, LIGHTWEIGHT DIGITAL FACSIMILE (LDF)	21-17

TABLE OF CONTENTS

<u>ORGANIZATION</u>	<u>SYSTEM / EQUIPMENT</u>	<u>PAGE</u>
CECOM LRC (Cont'd)		
<i>COMMUNICATIONS DIRECTORATE</i>		
	MK-2488/G, INSTALLATION KIT	21-18
	OG-174/VRC, AMPLIFIER POWER SUPPLY	21-19
	SB-3614(V)A/TT, SWITCHBOARD	21-20
	FIBER OPTICS TRANSMISSION SYSTEM (FOTS)	21-21
	REGENCY NET (RN) SYSTEM	21-22
	VEHICULAR INTERCOMMUNICATIONS SYSTEM (VIS)AN/VIC-3(V)	21-23
<i>IEWS DIRECTORATE</i>		
	AN/GRQ-27, GOLDWING	22-1
	AN/PAQ-4C, INFRARED AIMING LIGHT (IAL)	22-2
	AN/PEQ-2A, INFRARED ILLUMINATOR	22-3
	AN/PPS-5B, RADAR SET	22-4
	AN/PPX-3(), INTERROGATOR SET	22-5
	AN/PRD-11, MINI-FIX	22-6
	AN/PRD-12, LIGHTWEIGHT MANTRANSPORTABLE RADIO DIRECTION FINDER(LMRDFS)	22-7
	AN/PVS-4, NIGHT VISION SIGHT, INDIVIDUAL SERVED WEAPON SIGHT	22-8
	AN/PVS-5A, 5B, 5C, NIGHT VISION GOGGLES	22-9
	AN/TLQ-17A(V), TRAFFICJAM	22-10
	AN/TLQ-33, ARMY HIGH FREQUENCY ELEC WARFARE SYSTEM (AHFEWS)	22-11
	AN/TMQ-31, METEOROLOGICAL DATA SYSTEM (MDS)	22-12
	AN/TMQ-38, METEOROLOGICAL MEASURING SET (MMS)	22-13
	AN/TMQ-41, METEOROLOGICAL MEASURING SET (MMS)	22-14
	AN/TMQ-42, HYDROGEN GENERATOR (HG)	22-15
	AN/TRQ-32A(V)2 TEAMMATE	22-16
	AN/TRQ-37, TACFIX	22-17
	AN/TRS-2V, PLATOON EARLY WARNING SYSTEM (PEWS)	22-18
	AN/TSQ-138, TRAILBLAZER	22-19
	AN/TSQ-152, TRACKWOLF	22-20
	AN/TSQ-199, ENHANCED TRACKWOLF (ET)	22-21
	AN/TVS-5, CREW SERVED WEAPON SIGHT	22-22
	AN/ULQ-19(V), SIGNAL JAMMER RACJAM	22-23
	AN/USD-9A, IMPROVED GUARDRAIL V (IGR V)	22-24
	AN/VVS-2, DRIVERS VIEWER	22-25
	EH-60A, QUICKFIX	22-26
	IMPROVED-REMOTELY MONITORED BATTLEFIELD SENSOR SYSTEM (I-REMBASS)	22-27
	NIGHT VISION INFRARED COMMON MODULES	22-28

TABLE OF CONTENTS

<u>ORGANIZATION</u>	<u>SYSTEM / EQUIPMENT</u>	<u>PAGE</u>
RDEC		
<i>C2SID</i>		
	ADVANCED CONCEPT TECH II SATELLITE MOVEMENT TRACKING SYSTEMS	23-1
	CECOM/C2SID SUPPORT TO SSCOM, PM, SOLDIER	23-2
	BATTLE COMMANDERS WORKSTATION - SPEECH RECOGNITION TECHNOLOGY	23-3
	BATTLESPACE C2 DECISION AIDS	23-4
	BATTLESPACE COMMAND AND CONTROL (BC2)	23-5
	BATTLESPACE COMMANDER'S WORK STATION	23-6
	DIFFERENTIAL GPS (DGPS) TECHNOLOGY	23-7
	NAVIGATION TECHNOLOGY	23-8
	RAPID FORCE PROJECTION INITIATIVE COMMAND & CONTROL (RFPI-C2)	23-9
	SOLDIER INDIVIDUAL POWER	23-10
	TACTICAL ELECTRIC POWER	23-11
	VEHICLE IN-LINE GENERATOR	23-12
<i>I2WD</i>		
	THIS SECTION IS NOT AVAILABLE IN THE NON-FOUO FORMAT	
<i>NVESD</i>		
	ADVANCED ELECTRONIC WARFARE SENSORS	25-1
	ADVANCED EOIR COUNTERMEASURES	25-2
	ADVANCED FOCAL PLANE ARRAY	25-3
	ADVANCED HELICOPTER PILOTAGE (AHP) TD	25-4
	ADVANCED MINE DETECTION SENSORS	25-5
	ADVANCED OPTICS AND DISPLAY APPLICATIONS	25-6
	ADVANCED RF COUNTERMEASURES	25-7
	ADVANCED SIGNATURE MANAGEMENT AND DECEPTION	25-8
	AERIAL SCOUT SENSORS INTEGRATION (ASSI)	25-9
	AIR/LAND ENHANCED RECONNAISSANCE & TARGETING (ALERT) ATD	25-10
	ARMY ATR EVALUATION	25-11
	HUNTER SENSOR SUITE ATD	25-12
	INTEGRATED COUNTERMEASURES	25-13
	INTEGRATED SENSOR MODELING AND SIMULATION	25-14
	INTEGRATED SENSORS & TARGETING	25-15
	LIGHTWEIGHT, AIRBORNE, MULTISPECTRAL, COUNTERMINE DET SYSTEM	25-16
	LOW COST EO/IR COUNTERMEASURES	25-17
	MINI EYESAFE LASER INFRARED OBSERVATION SET (MELIOS) (AN/PVS-6)	25-18
	MICRO EYESAFE SOLID STATE LASER SOURCES	25-19
	MINE HUNTER/KILLER	25-20
	MULTI-FUNCTION STARING SENSOR SUITE ATD	25-21
	MULTI-MISSION/COMMON MODULAR UAV SENSORS	25-22
	MULTISPECTRAL COUNTERMEASURES ATD	25-23
	MULTI-WAVELENGTH MULTI-FUNCTION LASER	25-24
	SOLID STATE NEAR IR SENSORS	25-25
	TARGET ACQUISITION ATD	25-26
	VEHICULAR MOUNTED MINE DETECTOR ATD	25-27

TABLE OF CONTENTS

<u>ORGANIZATION</u>	<u>SYSTEM / EQUIPMENT</u>	<u>PAGE</u>
<i>S&TCD</i>		
	AIRBORNE RELAY	26-1
	AN/GSC-40, COMBINED GROUND COMMAND POST TERMINAL	26-2
	AN/GSR-42, SINGLE CHANNEL TRANSPONDER RECEIVING SET (SCTRS)	26-3
	AN/MSC-64, SINGLE CHANNEL UHF SPECIAL COMMUNICATIONS SYS-FORCE TERMINAL	26-4
	AN/USC-28(V), SATELLITE COMMUNICATIONS SET	26-5
	CX-13295/G, TACTICAL FIBER OPTIC CABLE ASSEMBLY (TFOCA) & ANCIL ITEMS	26-6
	DIGITAL BATTLEFIELD COMMUNICATIONS (DBC)	26-7
	DIGITAL COMMUNICATIONS SATELLITE SUBSYSTEM (DCSS)	26-8
	DIRECT BROADCAST SATELLITE (DBS)	26-9
	INTEGRATED PHOTONIC SUBSYSTEMS (IPS)	26-10
	PCS FOR THE SOLDIER	26-11
	TRI-BAND SATCOM SUBSYSTEM (TSS)	26-12
	UHF SATCOM ON-THE-MOVE ANTENNA	26-13

TABLE OF CONTENTS

<u>ORGANIZATION</u>	<u>SYSTEM / EQUIPMENT</u>	<u>PAGE</u>
SOFTWARE ENGINEERING CENTER		
	ARMY INTEROPERABILITY NETWORK (AIN)/C4I INTEROP NETWORK ACTIVITY	27-1
	VARIABLE MSG FORMAT TEST TOOL & MIL-STD-188-220 PROTOCOL TEST TOOL	27-2
	VARIABLE MESSAGE FORMAT & MIL-STD-188-220 STANDARDS	27-3
SYSTEMS MANAGEMENT CENTER		
<i>SMC</i>		
	BASE SUPPORT TRUNKED RADIO SYSTEM (BSTRS)	28-1
	LONG TERM LIFE CYCLE SUPPORT (LTLCS)	28-2
<i>PM, SCP</i>		
	SMALL COMPUTER PROGRAM (SCP)	29-1
<i>PM, DCASS</i>		
	COMMON USER INSTALLATION TRANSPORT NETWORK (CUITN)	30-1
	DIGITAL SWITCHED SYSTEMS MOD PROGRAM (DSSMP)	30-2
	MACOM TELEPHONE MODERNIZATION PROGRAM (MTMP)	30-3
	OUTSIDE CABLE REHABILITATION PROGRAM (OSCAR)	30-4
<i>PM, DCATS</i>		
	AN/FGQ-13, SMART MULTI-CIRCUIT TERMINAL (SMCT)	31-1
	AN/FSC-78/79, HEAVY TERMINAL & AN/GSC-39(V)2, MEDIUM TERMINAL	31-2
	AN/FSC-91, SATELLITE CONFIGURATION CONTROL ELEMENT (SCCE)	31-3
	AN/FSC-96 & AN/GSC-51, DEFENSE SATELLITE COMM SYS FREQ (DFCS)	31-4
	AN/FYQ-110 & AN/FSQ-142, DSCS OPERATION SPT SYS/DSCS AUTO SPEC ANAL	31-5
	AN/GSC-49(V)1, (V)2, AND (V)3, JRSC TERMINALS	31-6
	AN/GSC-52(V), STATE-OF-THE-ART MEDIUM TERMINAL (SAMT)	31-7
	AN/TSQ-172, CONTINENGY SATELLITE CONFIG CONTROL ELEMENT (CSCCE)	31-8
	DEFENSE SAT COMM SYS ELEC COUNTER COUNTER MEAS CONTROL SUBSYS (DECS)	31-9
	RBATSON	31-10
	REPLACEMENT SATELLITE CONFIGURATION CONTROL ELEMENT (RSCCE)	31-11
	UNIVERSAL MODEM (UM)	31-12
<i>PM, FIREFINDER</i>		
	FIREFINDER SYSTEMS	32-1
	AN/TPQ-36, FIREFINDER MORTAR LOCATING RADAR	32-2
	AN/TPQ-36, FIREFINDER MORTAR LOCATING RADAR, ELECTRONICS UPGRADE	32-3
	AN/TPQ-37, FIREFINDER ARTILLERY LOCATING RADAR	32-4
	AN/TPQ-37V, ATG MOBILITY IMPROVEMENT PROGRAM	32-5
	AN/TPQ-37V, ENHANCED FIREFINDER BLOCK I (EFF)	32-6
	FIREFINDER BLOCK II	32-7
	SHORTSTOP	32-8
	SHORTSTOP ELECTRONIC PROTECTION SYSTEM (SEPS)	32-9
<i>PM, GPS</i>		
	GLOBAL POSITIONING SYSTEM (GPS)	33-1
<i>PM, MEP</i>		
	DEPLOYABLE POWER GENERATION & DISTRIBUTION SYSTEM (DPGDS)	34-1
	MILITARY TACTICAL GENERATOR SET (2KW)	34-2
	TACTICAL QUIET GENERATOR SETS (3KW)	34-3
	TACTICAL QUIET GENERATOR SETS (5-60KW)	34-4
	UTILITY GENERATOR SETS (100-200KW)	34-5

TABLE OF CONTENTS

<u>ORGANIZATION</u>	<u>SYSTEM / EQUIPMENT</u>	<u>PAGE</u>
		<u>PAGE</u>
APPENDIX A: ALPHABETICAL INDEX BY ACRONYM		A-1
APPENDIX B: SYSTEM/EQUIPMENT BY NOMENCLATURE		B-1
APPENDIX C: ALPHABETICAL INDEX BY SYSTEM/EQUIPMENT NAME		C-1

PEO C3S

PM, ADCCS

PM, ADCCS

**AN/TSQ-73, MODIFICATION TO INTEGRATE
PATRIOT, HAWK, KSA WEAPON SYSTEMS**

PROJECT MGR: COL T. Haller,
DSN 788-3441
COMM 205/895-3441

PRODUCT MANAGER: Mr. Jim Beach (Acting),
DSN 788-3517
COMM 205/895-3517

ACQUISITION CATEGORY:
ACQUISITION PHASE:

PE & LINE #:

DESCRIPTION: The Security Assistance Management Directorate (SAMDM) implemented a Foreign Military Sales (FMS) case (SR-B-JBV) with the Kingdom of Saudi Arabia (KSA) to procure the Patriot Missile System. The introduction of Patriot requires the necessary modifications to the Royal Saudi Arabian Air Defense Forces (RSADF) Command, Control, and Communications (C3) System to allow Patriot and subsequently HAWK Phase III to be integrated into the air defense environment. This effort will involve the modification of the KSA AN/TSQ-73 to allow the integration of Patriot, HAWK and Saudi Weapon Systems, and will resolve some of the differences between the US and Saudi data link structure.

TRANSPORTATION CHARACTERISTICS / LIMITATIONS:

HISTORICAL BACKGROUND:

- o FMS Case Signed.
- o ADCCS Study effort.
- Jul 93 ADCCS Draft SOW and brief to LTC Sadek, RSADF.
- Sep 94 Source Selection process starts.
- Feb 95 SOW Finalization.
- Jul 95 RFP Release In-Country (KSA).
- Aug 95 CPECR Generation.
- Jan/Feb 96 Contract Document Run.
- Feb 96 Proposals submitted to RSA.
- Sep 96 RSADF directs Sole Source.

REQUIREMENTS DOCUMENT: FMS Case No. SR-B-JBV SAMDM letter to PM ADCCS entitled "Air Defense Command and Control (ADCC) Integration Upgrade for the Royal Saudi Air Defense Force (RSADF)".

TYPE CLASSIFICATION:

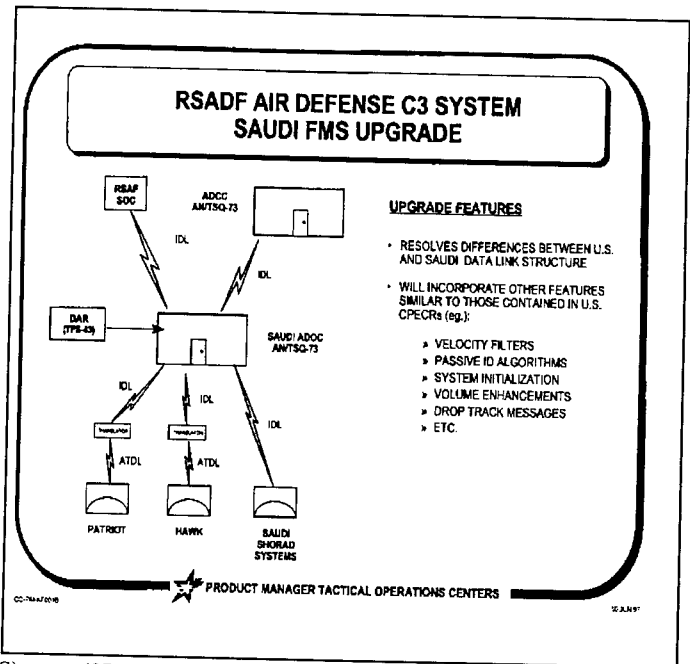

SYNOPSIS: THE KSA AN/TSQ-73 UPGRADE WILL PROVIDE THE RSADF INTEROPERABILITY WITH ALL OF THE RSADF WEAPON SYSTEMS.

PM, ADCCS

**AIR AND MISSILE DEFENSE COMMAND
(AAMDC)/FORCE PROJECTION (FP)
TACTICAL OPERATIONS CENTER (TOC)**

PROJECT MANAGER: COL T. Haller,
DSN 788-3441
COMM 205/895-3441

PRODUCT MANAGER: LTC J. Althouse,
DSN 788-3230
COMM 205/895-3230

ACQUISITION CATEGORY:
ACQUISITION PHASE: MS

PE & LINE #:

DESCRIPTION: The FP TOC in initial configuration provided to US Army Space Command (ARSPACE), consists of five (5) HMMWV's, five (5) Standardized Integrated Command Post System (SICPS) Rigid Wall Shelters (RWS), and six (6) SICPS tents. The HMMWVs with SICPS RWS also have on-board 12.5kw power units. The FPTOC provides a unique capability for the planning, coordination, and execution of both the Army and Joint Theater Missile Defense (TMD) battle. It was built at the direction of the Chief of Staff of the Army to provide a seamless, synergistic integration across the services and the four pillars of TMD (active defense; passive defense; attack operation; and battle management/command, control, communications, and intelligence). The FPTOC shelters are populated with automated systems (ASAS, AFATDS, MCS, AMBCIS, CTAPS, JTAGS RWS, JTAGS, GALE and ADSI), which provide on the Air and Missile Defense Workstations (AMDWS), a fused situation awareness with air breathing tracks, TBM, enemy and friendly ground situation weapon and sensor coverage on DTED or ADRG DMA maps. During early entry operation, the FPTOC can direct ATACMS missions against TBM targets. The FPTOC integrates available ABCS automated systems and supports robust communications interfaces including satellite, air to ground, and ground to ground. The AAMDC focus is to use its automation capability to prepare for future operations for the entire staff (S1, S2, S3, S4) and maintain situational awareness of the battlefield. The AAMDC provides the senior Theater Air Defense Artillery (ADA) commander with the required support to maintain command and control of the ADA air and missile defense forces for the Army commander. The AAMDC does not exercise real-time control over the air and missile defense battles, but delegates that responsibility to lower echelons. The mission of the AAMDC is to serve as a multi-functional organization with responsibilities as the Air and Missile Defense integrator for the Army Land Component Commander. These functions include the missile defense coordinator, the theater area air defense coordinator, the Deputy Area Air Defense Commander, current operations, future operations, and deconfliction and coordination of air and missile defense operations.

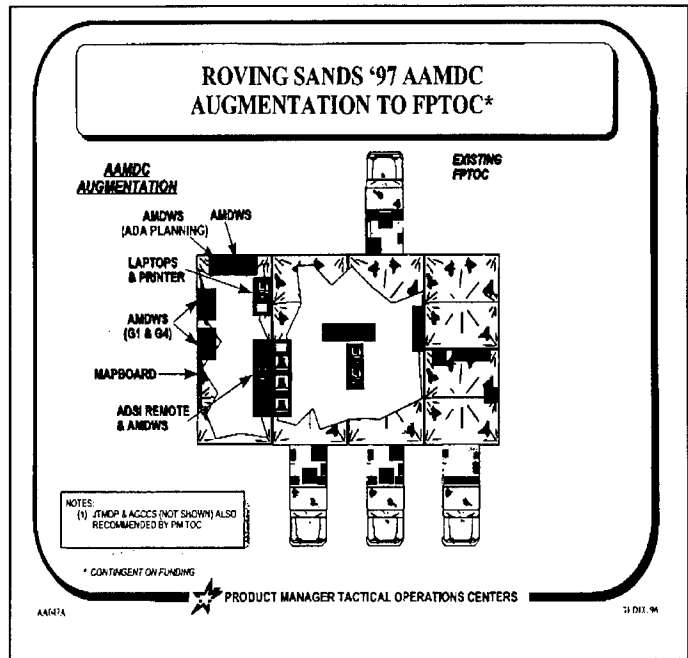

TRANSPORTATION CHARACTERISTICS / LIMITATIONS: Deployable by C-130 or larger.

HISTORICAL BACKGROUND:

- May 95 FPTOC successfully demonstrated at ROVING SANDS.
- Oct 95 FPTOC endorsed by Army Chief of Staff as a prototype TOC.
- Apr 96 FPTOC upgrades completed.
- Jun 97 ROVING SANDS '97.

REQUIREMENTS DOCUMENT:

TYPE CLASSIFICATION:

EVENT SCHEDULE	FISCAL YEAR	97		98		99		00		01		02	
		QTR	1	2	3	4	1	2	3	4	1	2	3
ROVING SANDS '97			3										
UFL (FPTOC)			4		4								

SYNOPSIS: THE FPTOC PROVIDES THE ARMY LCC EARLY ENTRY CAPABILITY FOR COMMAND AND CONTROL OF THE TBM FIGHT AND THE FOCAL POINT TO CONTINUE PROSECUTION OF THE TBM FIGHT AS THE THEATER MATURES. THE AAMDC TOC SUPPORTS THE SENIOR THEATER ADA COMMANDER WHO PROVIDES COMMAND AND CONTROL OF THE ADA AIR AND MISSILE DEFENSE FORCES FOR THE ARMY COMMANDER.

PM, ADCCS

AIR AND MISSILE DEFENSE PLANNING AND CONTROL SYSTEM (AMDPCS)

PROJECT MANAGER: COL T. Haller,
DSN 788-3441
COMM 205/895-3441

PRODUCT MANAGER: LTC Edward Siomacco,
DSN 788-4309
COMM 205/895-4309

ACQUISITION CATEGORY:
ACQUISITION PHASE:

PE & LINE #:

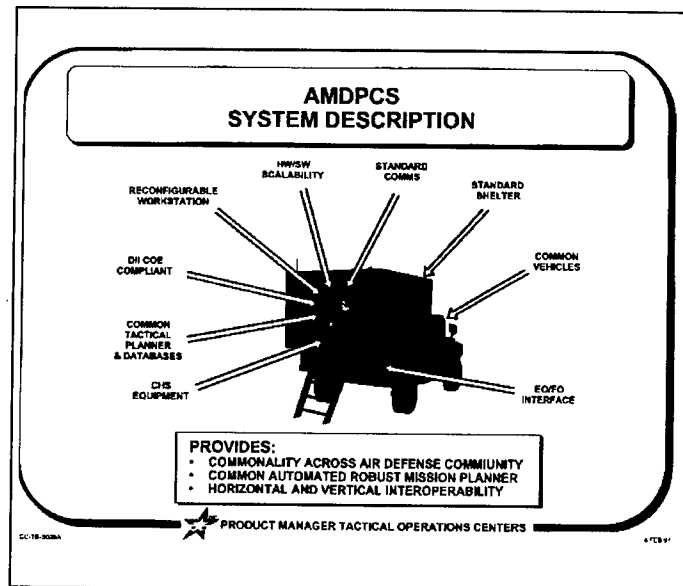

DESCRIPTION: The Air and Missile Defense Planning and Control System (AMDPCS) Command Post (CP) will consist of processors, displays, software, and communications equipment to meet the staff planning Force operations needs of FAAD, PATRIOT, and other Extended Air Defense systems, using available ATCCS S/W and Common Army Hardware/Software (CHS). The Tactical Operations Center (TOC) will use a Standard Integrated Command Post System (SICPS) shelter mounted on a HMMWV.

TRANSPORTATION CHARACTERISTICS / LIMITATIONS:

HISTORICAL BACKGROUND:

Jul 93 Inception of Idea.

REQUIREMENTS DOCUMENT: PATRIOT PAC III ORD, ADTOC UFD. AMDPCS ORD.

TYPE CLASSIFICATION:

EVENT SCHEDULE	FISCAL YEAR		97	98	99	00	01	02
	QTR		1 2 3 4	1 2 3 4	1 2 3 4	1 2 3 4	1 2 3 4	1 2 3 4
Released ORD			1					

SYNOPSIS: THE AIR DEFENSE STAFF PLANNING VAN WILL PROVIDE S1/S4 CAPABILITIES AT BDE AND BELOW.

PM, ADCCS

AIR AND MISSILE DEFENSE WORKSTATION (AMDWS)

PROJECT MANAGER: COL T. Haller,
 DSN 788-3441
 COMM 205/895-3441

ACQUISITION CATEGORY:
ACQUISITION PHASE: MS

PE & LINE #:

DESCRIPTION: AMDWS integrates FAAD C2, Patriot, THAAD (and eventually MEADS) force operations software (Defense planning, staff functions) with ATA/COE and Force XXI interoperability techniques (client/server) to provide command air and missile defense workstations for all echelons of command. It provides a common planning module to be incorporated into Joint Air/Missile defense planning tools (TBMCS, JMOIS, GCCS).

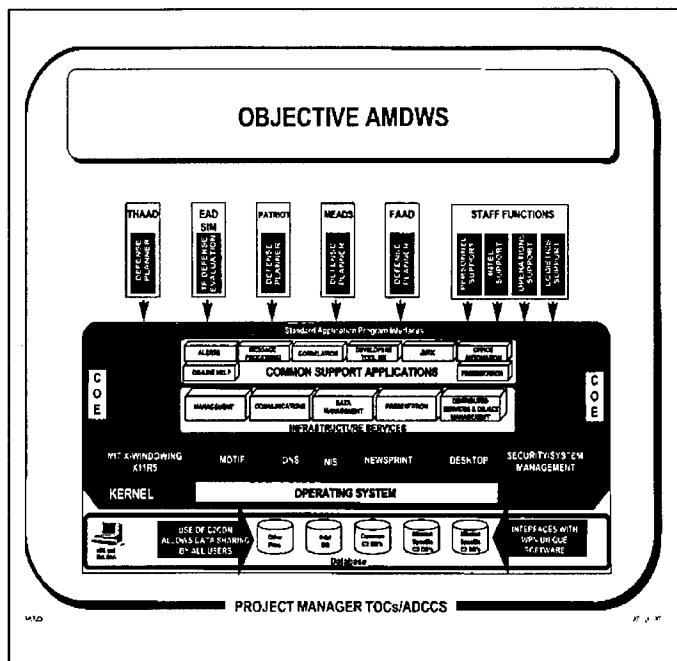

TRANSPORTATION CHARACTERISTICS / LIMITATIONS:

HISTORICAL BACKGROUND:

REQUIREMENTS DOCUMENT:

TYPE CLASSIFICATION:

EVENT SCHEDULE	FISCAL YEAR	97		98		99		00		01		02	
		QTR	1	2	3	4	1	2	3	4	1	2	3
V1.0 to support FAAD in MCS IOT&E				1									
V1.1 to support Patriot PAC3 FOTE				3									
V2.0 to support THAAD UDES						3							

SYNOPSIS: AMDWS SUPPORTS THE STAFF PLANNING FUNCTIONS AT VARIOUS AIR DEFENSE ARTILLERY COMMAND ECHELONS.

PM, ADCCS

AIR DEFENSE ARTILLERY BRIGADE TACTICAL OPERATIONS CENTER (ADA BDE TOC)

PROJECT MGR: COL T. Haller,
DSN 788-3441
COMM 205/895-3441

PRODUCT MGR: LTC J. Althouse,
COMM 205/895-4309

ACQUISITION CATEGORY:
ACQUISITION PHASE: MS

PE & LINE #:

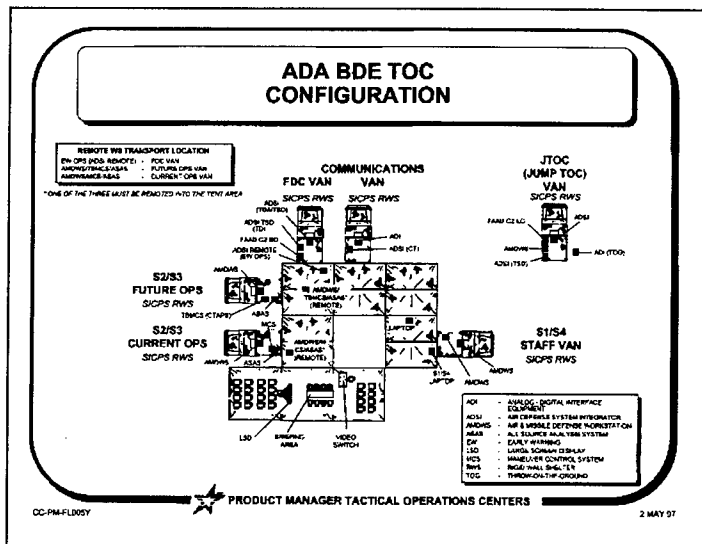

DESCRIPTION: The ADA Brigade TOC consists of six (6) HMMWV with Standardized Integrated Command Post System (SICPS) Rigid Wall Shelters (RWS), connected by tents to form a self-contained command and control element. The shelters are populated with automated systems to provide the commander with intelligence, tactical planning capability, air picture from multiple sources, air defense fire direction capability, admin/log staff functions and robust multi-mode communications. The TOC provides the Brigade commander critical new capabilities including real-time Tactical Ballistic Missile threat intelligence from space-based assets, a single-vehicle Jump TOC for echeloned redeployment, automated C2 links to Forward Area Air Defense (FAAD) and HIMAD/TMD High and Medium Altitude Air Defense/Theater Missile Defense units, real-time air picture from Airborne Warning and Control System (AWACS), automated C2 linkages with higher headquarters, and automated roll-up of subordinate units logistics and personnel status. It is highly mobile, transportable by C-130 and C-141 aircraft, and interoperable over a vast array of tactical communications to both Army and Joint Services.

TRANSPORTATION CHARACTERISTICS / LIMITATIONS: Consists of 6 HMMWV-mounted SICPS Rigid Wall Shelters (RWS) towing 10kw prime power units. Air transportable by C-130 and larger.

HISTORICAL BACKGROUND:

- FY93 Experimental automated TOC concepts validated at Exercise Roving Sands.
- FY94 Prototype 5-ton vehicle mounted TOC fielded to 2 Bdes and exercised at Roving Sands.
- FY95 Prototype HMMWV-mounted TOC fielded to 31st ADA Bde - exercised at Roving Sands '95.
- Oct 95 TOC fielded to 11th ADA Bde.
- Mar 97 TOCs deployed to 35th and 108th ADA Bdes.
- May 97 AMDPCS ORD approved by TRADOC.

REQUIREMENTS DOCUMENT: AMDPCS ORD, May 97.

TYPE CLASSIFICATION:

EVENT SCHEDULE	FISCAL YEAR	97				98				99				00				01				02			
		QTR				1	2	3	4	1	2	3	4	1	2	3	4	1	2	3	4	1	2	3	4
Prototype fielding - 35 th and 108 th ADA Bdes		2																							
Initial Training set fielding to training base		2																							
Prototype fielding - 69 th ADA Bde						2																			
Follow-on training set fielding to training base										2															

SYNOPSIS: THE ADA BDE TOC IS AN AUTOMATED SYSTEM OF SYSTEMS PROVIDING THE ADA BDE COMMANDER AIR AND GROUND SITUATION AWARENESS, INTELLIGENCE, AND THE MEANS TO EXERCISE TACTICAL CONTROL.

PM, ADCCS

ADTOC COMM PROCESSOR
(formerly AIR DEFENSE SYSTEMS INTEGRATOR
(ADSI)/Joint TADIL A Distribution System (JTADS)]

PROJECT MGR: COL T. Haller,
DSN 788-3441
COMM 205/894-3441

PRODUCT MANAGER: LTC Siomacco,
COMM 205/895-4309

ACQUISITION CATEGORY:
ACQUISITION PHASE:

PE & LINE #:

DESCRIPTION: The basic ADTOC Comm Processor system receives TADIL A HF/UHF data, converts it to TADIL B, and using modems, sends the data to an Army Air Defense Artillery system over a hard wire connection. Current software capabilities have been expanded to accomplish the following:

1. Provide TADIL A duplex capability.
2. Add a second TADIL A receiver to permit over the air frequency adjustments.
3. Provide UHF duplex radios for TADIL A and satellite communication.
4. Provide multiple TADIL B ports.
5. Accept and forward TIBS and TRAP data from a CTT.
6. Accept data from multiple radar sources.
7. Correlate all the surveillance data to provide a single air picture.
8. Capability to act as a command and information center. The system does not currently control weapon/missile fires.
9. Planning aid for communications and sensor placement including maps and areas of coverage.

TRANSPORTATION CHARACTERISTICS / LIMITATIONS:

HISTORICAL BACKGROUND:

FY94 ADSI Systems installed in 3 automated ADA Brigade JTOCs.
FY94 ADSI System installed in Prototype Force Projection TOC (FPTOC).
FY95 ADSI Systems installed in 2 new SICPS-based ADA Brigade TOCs.
FY95 ADSI System installed in 1 Automated ADA Brigade JTOC.
FY95 ADSI System installed in EUCOM CIC TMD Cell.
FY96 ADSI System installed in USFK, CENTCOM and CINC TMD Cell.
FY96 ADSI System installed in 2 Brigade ADTOCS.
FY97 ADSI System installed in 2 Brigade TOCs.

REQUIREMENTS DOCUMENT: Desert Storm - Required for joint interoperability. Operational Needs Statement - Joint TADIL A Distribution System (JTADS), May 93. ORDs for TADIL A capability included in Air Defense Systems (PATRIOT PAC 3, THAAD, FAAD C2I BLOCK 2 ADTOC).

TYPE CLASSIFICATION:

SYNOPSIS: THE ADSI EFFORT WILL STANDARDIZE AND PRODUCE SUFFICIENT ADSI SYSTEMS TO MEET THE CURRENT ARMY NEED FOR TADIL A INTEROPERABILITY WITH JOINT AND ALLIED SYSTEMS.

PM, ADCCS

**ANNEX C EXTENDED AIR DEFENSE (EAD)
COMMON INTEROPERABILITY PROGRAM**

PROJECT MANAGER: COL T. Haller,
DSN 788-3441
COMM 205/895-3441

ACQUISITION CATEGORY:
ACQUISITION PHASE: MS

PE & LINE #: 060379D

DESCRIPTION: Under Annex C to the EAD MDA dated 17 May 1989, the cooperative program investigates existing C3I operational concepts and architectures to determine interoperability requirements for effective EAD. Annex C addresses deficiencies in Battlefield Development Plan "Inadequate Joint and Combined C2 Interoperability" by providing common Interchange requirements specification for US and Germany.

TRANSPORTATION CHARACTERISTICS / LIMITATIONS: N/A

HISTORICAL BACKGROUND:

Prior to program initiation the US and Germany were only interoperable in engagement operations. The task 4 study mandated a capability for either a US ADTOC (AMDPCS) or a German SAMUC to provide both EO and FO interoperability C2.

REQUIREMENTS DOCUMENT:

US/GE Task 4 Bilateral Enclave Operational Concept Document, August, 1993.

TYPE CLASSIFICATION:

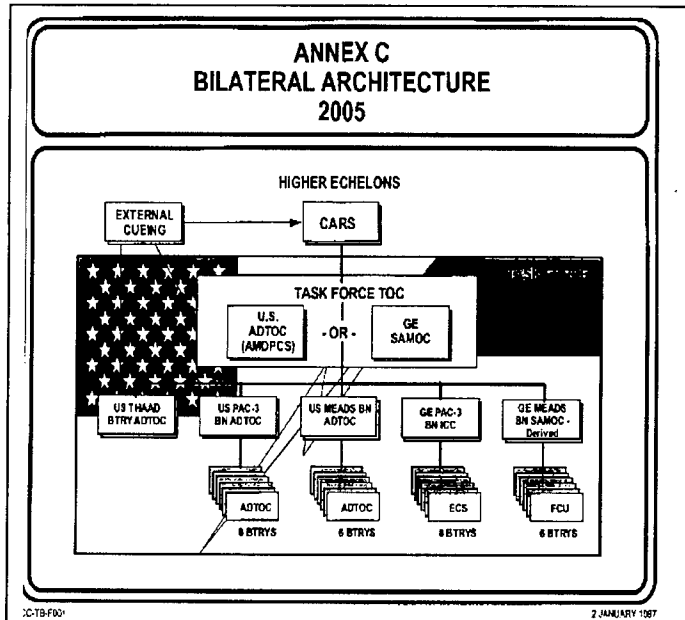

<u>EVENT SCHEDULE</u>	FISCAL YEAR	97				98				99				00				01				02			
		QTR				1	2	3	4	1	2	3	4	1	2	3	4	1	2	3	4	1	2	3	4
Bilateral Analysis/Definition				4									4												
Risk Mitigation Testing				4									2												
National Development												3									3				
Bilateral Operational Testing																1									2
Manufacturing and Fielding																								1	4

SYNOPSIS:

PM, ADCCS

ARMY TACTICAL OPERATIONS CENTERS (TOC)

PROJECT MANAGER: COL T. Haller,
DSN 788-3441
COMM 205/895-3441

PRODUCT MANAGER: LTC J. Althouse,
DSN 788-4069
COMM 205/895-4069

ACQUISITION CATEGORY:
ACQUISITION PHASE: MS

PE & LINE #: 64818C39 (RDT&E)
BZ9865 (OPA2)

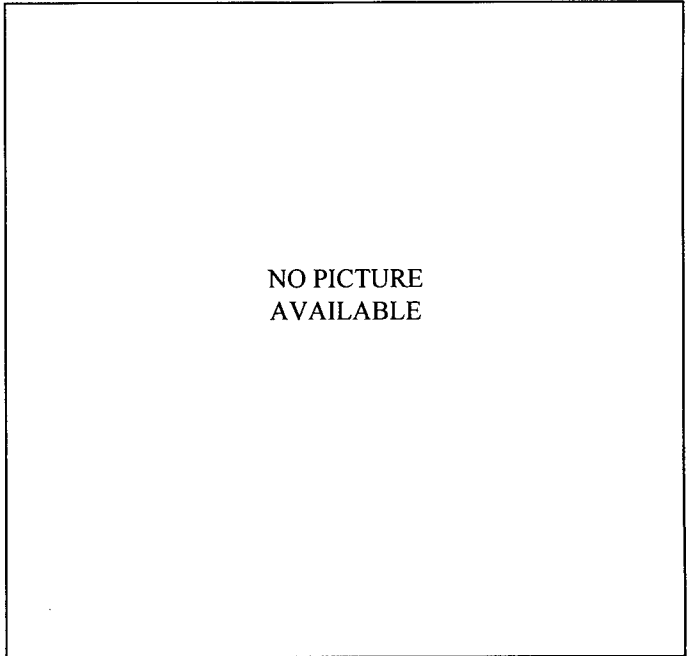

DESCRIPTION: Army TOCs are the automated facilities where commanders will plan, control, maintain situational awareness, and execute battle command. For the Digitized Army, TOCs will incorporate:

- Army Battle Command Systems (AGCCS, five ATCCS systems, and Force XXI Battle Command – Brigade and Below (FBCB2)) providing the framework for the digitized battlefield.
- Fully integrated and digitally linked Battlefield Operating Systems (BOSS).
- The requirements mandated by the Army Technical Architecture (ATA) and the Defense Information Infrastructure (DII) Common Operating Environment (COE).

A centrally-managed TOC program is key to achieving "Information Dominance". Army TOCs are the C2 nodes where information based operations will be planned, controlled and updated in real time as the situation and METT-T evolve/change. A standard/common TOC operational architecture and system architecture tailored to the echelon of command and mission area will be developed to assure interoperability and commonality.

TRANSPORTATION CHARACTERISTICS / LIMITATIONS: All shelters and equipment are mounted/transported on Army standard prime movers, e.g., HMMWV, M-1068, M934, C2V.

HISTORICAL BACKGROUND: Digitized Army TOCs have evolved as an essential component of the Army digitization efforts. Task Force XXI and Division XXI Advanced Warfighting Experiments have demonstrated the modularity, interoperability and information dominance benefits of standard, integrated and automated TOCs. In January 1997, CSA directed that an Army TOC Program be established. A separate line in the budget was established and project manager assigned. On 1 August 1997, the DSCSOPS announced that The Army Plan would incorporate; fielding of the digitized corps by FY04, the first digitized division by FY00, and the second digitized division completed by FY03.

REQUIREMENTS DOCUMENT: ABCS Capstone Requirements Document, ATA, AVTOC ORD.

TYPE CLASSIFICATION: TBD.

EVENT SCHEDULE	FISCAL YEAR											
	97		98		99		00		01		02	
	QTR		QTR		QTR		QTR		QTR		QTR	
	1	2	3	4	1	2	3	4	1	2	3	4
4ID Upgrade/Fielding Remaining					1				4			
ICD Fielding					4							1
III Corps Fielding									4			

SYNOPSIS: THE ARMY TOC PROGRAM PROVIDES THE WARFIGHTER AN INTEGRATED C2 FACILITY WITHIN WHICH INFORMATION DOMINANCE WILL BE ASSURED AND THE INFORMATION WAR WILL BE WON.

PM, ADCCS

**COMMANDER-IN-CHIEF THEATER
MISSILE DEFENSE (CINC TMD)**

PROJECT MANAGER: COL T. Haller,
DSN 788-3441
COMM 205/895-3441

PRODUCT MANAGER: LTC E. Siomacco,
DSN 788-4309
COMM 205/895-4309

ACQUISITION CATEGORY:
ACQUISITION PHASE: MS

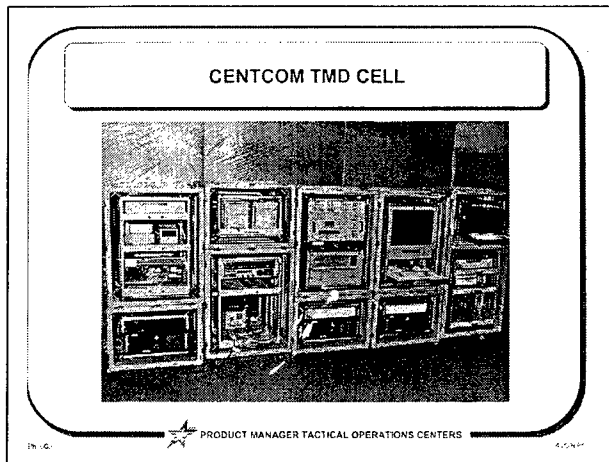

PE & LINE #:

DESCRIPTION: The CINC TMD cells integrate existing intelligence information and analysis applications to provide situational awareness of current TMD activities on the battlefield. TMD cells augment the existing capability found in the various CINC Tactical Operations Centers (TOC) with each cell configured to meet the specific needs of the Theater. Each TMD cell consists of communications equipment and software applications that enable an operator to monitor the TMD related activity throughout a theater. Each cell can be configured to receive and process messages from JTAGS, CTAPS, SIDS, TIBS, TDDS (TRAP), TADIL-A, TADIL-B, JMCIS, OTCIXS, OTH-GOLD and STACCS. Currently three cells are fielded - USEUCOM, USCENTCOM and USFK with the ACOM cell delivery scheduled for 1 Oct 97. EUCOM/ACOM are mobile configuration (HWWMV/SICPS), CENTCOM is a transit case configuration and USFK is a table top configuration. In its current configuration, the CENTCOM/USFK cells are soldier operated and contractor maintained. EUCOM is now primarily soldier supported with minimal contractor support.

TRANSPORTATION CHARACTERISTICS / LIMITATIONS: All cells are C130 Deployable. EUCOM cell carries organic generator power, whereas CENTCOM/USFK cells do not. All can adapt to any power available within AOR.

HISTORICAL BACKGROUND:

- May 94 USEUCOM identifies requirements to automate and integrate TMD capabilities.
- Nov 94 Delivery of EUCOM TMD cell.
- Apr 95 Deployment of EUCOM TMD cell in support of Roving Sands in Texas.
- Oct 95 Decision to retrofit EUCOM cell into HMMWVS in SICPS.
- Oct 95 Decision to field cells with all CINCS made by BMDO.
- Feb 96 CENTCOM system fielded at Internal Look '96.
- Apr 96 Refitted EUCOM fielded at Optic Windmill.
- May 96 PACOM/USFK system fielded at Cobra Gold '96.
- Aug 96 USFK system delivered to Osan, Korea, participated in UFL '96.
- Oct 97 EUCOM upgrade/ACOM system fielded.

REQUIREMENTS DOCUMENT: N/A

TYPE CLASSIFICATION: N/A

<u>EVENT SCHEDULE</u>	FISCAL YEAR	97		98		99		00		01		02	
		1	2	3	4	1	2	3	4	1	2	3	4
Completion of EUCOM TMD Cell Retrofit				1									
Delivery of ACOM TMD Cell				1									
Completion of CENTCOM TMD Cell Retrofit				2									

SYNOPSIS: CINC TMD CELLS INTEGRATE EXISTING INTELLIGENCE INFORMATION AND ANALYSIS APPLICATIONS TO PROVIDE SITUATIONAL AWARENESS OF CURRENT TMD ACTIVITIES ON THE BATTLEFIELD.

PM, ADCCS

FORWARD AREA AIR DEFENSE COMMAND AND CONTROL (FAADC2)

PROJECT MGR: COL T. Haller,
DSN 788-3441
COMM 205/895-3441

PRODUCT MANAGER: LTC E. Siomacco,
DSN 788-4309
COMM 205/895-4309

ACQUISITION CATEGORY: IC
ACQUISITION PHASE: Production (Block II),
EMD (Block III)

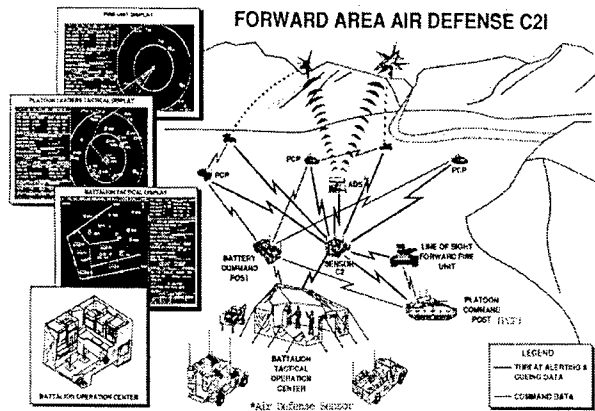

PE & LINE #: AD5050 (Block II), 64741.0126 (Block III)

DESCRIPTION: The FAADC2 system supports the Short Range Air Defense (SHORAD) battalion mission by providing C2I information to higher, adjacent, and lower units. The FAAD C2 mission encompasses the detection, acquisition, and identification of helicopters, fixed-winged aircraft, and unmanned aerial vehicles; the distribution and dissemination of C2I data among the ADA units and combined arms elements; the provision of early warning; and alerting to the supported forces. To accomplish its mission, FAAD C2 is integrated into and will interoperate with both the Army Battle Command System (ABCS) using the Air and Missile Defense Workstation (AMDWS). The AMDWS is integrated in FADDC2 equipped battalions at the ADA battery and battalion command posts. The AMDWS is a product under the Air and Missile Defense Planning and Control System (AMDPCS).

The FAAD C2 system consists of common hardware, software and communications equipment to meet the command and control and targeting needs of SHORAD battalions and separate batteries. Computer displays will allow commanders access to databases for the air picture, situation reports, enemy assessments, and friendly forces. The amount of data base access varies at each SHORAD echelon. It will handle information classified up to SECRET. The system provides an imbedded training simulation capability that will replicate those situations encountered in actual mission operation. Evolving software capabilities are added by new versions across the FAAD C2 (Block III) development cycle.

The FADDC2 system supports the Low Level Air Picture Interface (LLAPI) development program. The LLAPI will develop and test a computer-to-computer digital interface as a bilateral implementation of Standardization Agreement (STANAG) 4312 Part II. The participating systems are the US FAAD C2 System and the German Army Air Defense Surveillance and Command and Control System (AADSACCS). The LLAPI successfully demonstrates interoperability between the US and German SHORAD assets for automated low level air picture exchange at the corps or division boundary between allied nations. The LLAPI implements a thirty meter physically secured cable between the FADDC2 Sensor C2 (AN/TSQ-183) subsystem and the German AADSACCS vehicle to exchange the low level air picture using STANAG 5516J-Series Fixed Word Format (FWF). Growth plan calls for development of a wireless operational concept in which the US and Germany will participate with the other NATO nations.

TRANSPORTATION CHARACTERISTICS / LIMITATIONS: The FAAD C2 vehicular subsystems are air (C141, C17, C130, and CH-47D (wheeled variant only)), rail, surface, and water transportable without disassembly from the carrier. The FAADC2 (soft-top shelter only) subsystems are airdrop capable.

HISTORICAL BACKGROUND:

Sep 86 Initial Contract FAAD C2I Award.
Jan 91 FAAD C2I Program Restructured for Light/Special Division (V3).
Feb 93 FAAD C2I Technical Test/Limited User's Test (V3).
May 93 PEO CCS Decision (LRIP) for Block I (Light/Special Division).
Sep 93 First Unit Equipped 101st AA (V3). (Block I).
Oct 93 Completion of Analysis/Definition Phase (LLAPI/FAST).
Jan 94 LLAPI/FAST Contract Negotiations/Award Prototype Development.
Aug 94 FAAD C2 (Block III) EMD Contract Awarded.
Nov 94 FAAD C2 IOT&E (Block II).
Feb 95 LLAPI/FAST Prototype Delivered.
Apr 95 HQDA approved FAAD C2 FRP (Block II) (Milestone III).
Oct 95 First Unit Equipped 3d ID (Block II).
Nov 95 Contract Negotiations/Award Full Scale Development for LLAPI/FAST.
Dec 95 STANAG 4312 part II Ratified for LLAPI/FAST.
Jul 96 Completed LLAPI/FAST Interoperability Test.
Sep 97 LLAPI/FAST MOU Amendment Negotiations.

REQUIREMENTS DOCUMENT: ROC approved Oct 85; Block II ROC approved Jul 92. O&O approved May 92, BLOCK I: V3. Current Block II ORD approved Jun 95.

TYPE CLASSIFICATION: PEO C3S approved low rate production for Block I (May 93). HQDA approved limited procurement for Block II Apr 95.

SYNOPSIS: THE FAAD C2 PROVIDES NEAR REAL TIME TARGETING & C2 INFORMATION, ACCURATE & TIMELY IDENTIFICATION OF TARGETS, ALERTING OF SHORAD & SUPPORTED UNITS, CUEING OF SHORAD WEAPONS, & INTEROPERABILITY WITH JOINT AND COMBINED ADA C2 SYSTEMS. THE US LLAPI CAPABILITY PROVIDES A LOW LEVEL AIR PICTURE EXCHANGE BETWEEN ALLIED CORPS AND DIVISION SHORAD UNITS.

PM, ADCCS

III CORPS ARTILLERY ASSAULT COMMAND POST/MAIN COMMAND POST

PROJECT MANAGER: COL T. Haller,
DSN 788-3441
COMM 205/895-3441

PRODUCT MANAGER: LTC J. Althouse,
DSN 788-3230
COMM 205/895-3230

ACQUISITION CATEGORY:
ACQUISITION PHASE:

PE & LINE #:

DESCRIPTION: The III Corps ACP and MCP both consist of a state of the art automated tactical operations center/command post. The ACP provides an early entry capability to the Corps Commander to control limited close operations, conduct force tracking, and conduct host nation coordination while the MCP synchronizes all Corps operations, conducts deep operations, plans future (deep, close and rear) operations, and allocates resources. The ACP consists of the G-3 Ops, G-2, G-6, and Fire Support Element (FSE) integrated by PM ADCCS and the Air Defense Artillery (ADA) and Trojan Spirit II shelters provided by III Corps. The SICPS shelters are the Rigid Wall Shelters (RWS) mounted on the M-1097 High Mobility Multi-Purpose Wheeled Vehicle (HMMWV). The MCP consists of the Command, G-3 Ops, Deployable Analysis and Control Element (DACE), Deep Operations Coordination Cell (DOCC) Execution, and Army Airspace Command and Control (A2C2) Large Standard Integrated Command Post (SICPS) Shelters (LSS); the G-2, G-3, G-3 Plans (Ops), G-3 Plans (SPT), G-3 Plans Combat Service Support (CSS), Engineering, Nuclear Biological and Chemical (NBC), Liaison Officer (LNO), G-6 Ops, G-6 SYS, II Corps Artillery (C/A), G-2 C/A, G-3, C/A Fire Control Element (FCE), Fire Support Element (FSE), and Air Support Operations Center (ASOC) in M-934A2 Expando Vans. All the shelters are integrated by PM ADCCS. The ACP utilizes the Audio/Visual (A/V) SICPS RWS mounted on the M-1097 HMMWV while the MCP utilizes the A/V SICPS in a Pershing Van. The ACP and MCP both utilize the Maneuver Control System (MCS/P) to provide critical battlespace information to the Commander, III Corps. Both ACP and MCP utilize the All Source Analysis System/Warrior (Raide), (ASAS/W)/Warlord to provide the intelligence picture with Trojan Lite providing additional information to the ACP. Both utilize the Advanced Field Artillery Tactical Data System (AFATDS) to provide the artillery battle plan and prioritize targets to ensure that high-payoff targets are attacked. In the MCP, the Combat Service Support Control System (CSSCS) provides CSS Command and Control and Situational Awareness to support decisions on the employment of resources while the Army Global Command and Control System (AGCCS) provides a single seamless Command and Control System. All computers are connected through a Local Area Network (LAN). Images resident on these systems may be imported by the Commander's Display suite for the Command Group within the ACP and by the Large Screen Displays for the MCP. Video Teleconferencing (VTEL) capability is produced by the A/V shelter. The MESHnet inter-communications system allows access to all radios and Mobile Subscriber Equipment.

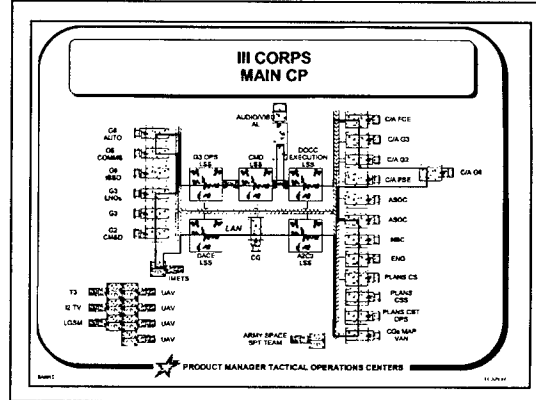
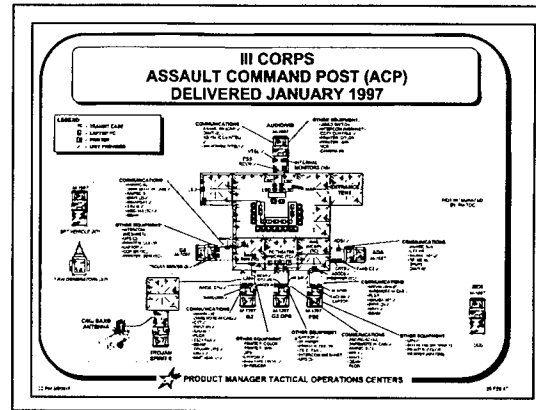

TRANSPORTATION CHARACTERISTICS / LIMITATIONS: ACP - C-141 transportable.

HISTORICAL BACKGROUND:

- Jul 95 ACP requested through Depth & Simultaneous Attack Battle Lab (Ft. Sill, OK).
- Jun 96 III Corp Chief of Staff directed PM-ADCCS to build and deliver III Corps ACP and MCP.
- Aug 96 ACP Contract Awarded.
- Oct 96 MCP Contract Awarded.
- Jan 97 III Corps ACP delivered.
- Jan 97 ACP Training complete.
- May 97 III Corps MCP delivered.
- May 97 MCP Training completed.

REQUIREMENTS DOCUMENT: None.

TYPE CLASSIFICATION: Rapid Prototype (MCP).

EVENT SCHEDULE	FISCAL YEAR	97		98		99		00		01		02	
		1	2	3	4	1	2	3	4	1	2	3	4
ACP Deployment		1											
MCP Contract Award		1											
MCP Delivery (March 3, 1997)		3											

SYNOPSIS:

PM, ADCCS

**US 3RD ARMY "LUCKY MAIN"
TACTICAL OPERATIONS CENTER (TOC)**

PROJECT MANAGER: COL T. Haller,
DSN 788-3441
COMM 205/895-3441

PRODUCT MANAGER: LTC Althouse, DSN 788-3230
COMM 205/895-3230

ACQUISITION CATEGORY:
ACQUISITION PHASE:

PE & LINE #:

DESCRIPTION: The US 3rd Army "Lucky Main" TOC will be a mobile command headquarters, transportable by C-141 Aircraft. It will consist of twelve (12) shelters (nine (9) Large Standardized Integrated Command Post System (SICPS) Shelters (LSS), and three (3) Modular Extendable Rigid Wall Shelters (MERWS) to handle current operations, future plans, communications, war game activities, admin functions and intelligence for the Commander of the 3rd Army in a deployed scenario. Automated and digitized capabilities will make this a "State-of-the-Art" TOC and provide a mobile command headquarters for the US Army's only deployable, Army-level headquarters.

TRANSPORTATION CHARACTERISTICS / LIMITATIONS: Mobile configuration, C-141 transportable.

HISTORICAL BACKGROUND:

- 3Q95 During Roving Sands '95, 3rd Army tours FPTOC and requests information for a proposed headquarters.
- FY96 Discussions continue between US 3rd Army and PM-ADCCS.
- 4Q96 Funds received to perform "Phase 1" of US 3rd Army "Lucky Main" TOC.
- 1Q97 Planning for contract for "Phase 1" continues. (Phase 1 will be consist of 4 shelters).

REQUIREMENTS DOCUMENT: TRADOC has approved an Operational Needs Requirement and forwarded to DCSOPS.

TYPE CLASSIFICATION:

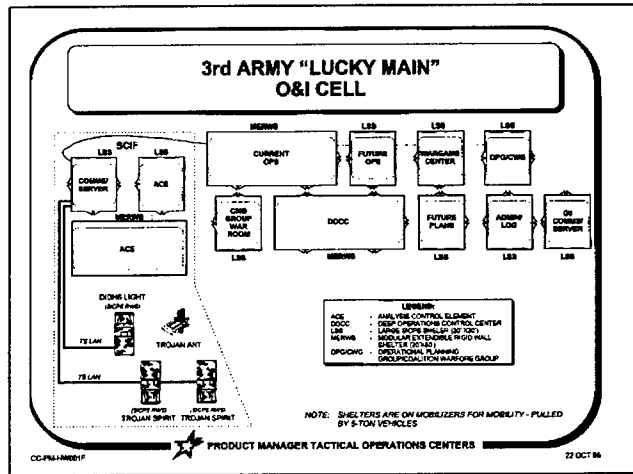

EVENT SCHEDULE	FISCAL YEAR	QTR																											
		97				98				99				00				01				02							
Proposed contract award (Phase 1)		1																											
Initial Design Review (Phase 1)		1																											
Final Design review (Phase 1)				4																									
Delivery of GFE/CFE (Phase 1)						1			3																				
Integration (Phase 1)						1			3																				
Integration Checkout (Phase 1)						1			3																				
Delivery of Phase 1 shelters to 3rd Army										4																			
Training										4																			

SYNOPSIS: MOBILE AUTOMATED TOC FOR US 3RD ARMY "LUCKY MAIN" COMMAND HEADQUARTERS.

PM, ADCCS

TASK FORCE/DIVISION XXI TACTICAL OPERATIONS CENTERS (TF/DIV XXI TOC)

PROJECT MANAGER: COL T. Haller,
DSN 788-3441
COMM 205/895-3441

PRODUCT MANAGER: LTC J. Althouse,
DSN 788-3230
COMM 205/895/3230

ACQUISITION CATEGORY:
ACQUISITION PHASE:
PE & LINE #:

DESCRIPTION: The TFXXI TOCs are a group of automated tactical operations centers/command posts integrated to support the 1st Brigade (BDE), 4th Infantry Division (4ID) Advanced Warfighting Experiment (AWE) conducted during March 1997. The TOCs integrate digital hardware systems being provided by other Program Executive Officer Command, Control and Communications Systems (PEO C3S) to improve Command post 1 (CP2); the BDE TOC, the BDE Tactical Alternate Command Post (TAC); the Brigade Support Area TOC, the 3rd Battalion, 66th Armor TOC; the 1st Battalion, 22nd Infantry TOC; the 1st Battalion, 5th Infantry TOC; the 4th Battalion, 42nd Field Artillery TOC; the 229th Engineer TOC; 3rd Battalion, 16th Field Artillery TOC; Aviation TF TOC and A/104 Military Intelligence Company Analysis and Control Team (MI ACT), the Advanced Field Artillery Tactical Data System (AFATDS), the Forward Area Air Defense C2 System (FAAD C2), the Combat Service Support Control System (CSSCS), and Single Channel Ground and Airborne Radio System Improvement Program (SINCGARS SIP) and Enhanced Position Location Reporting Systems (EPLRS) radios along with other communications and peripheral devices. TF XXI TOCS incorporate AFATDS, CSSCS and All Source Analysis System Remote Workstations (ASAS RWS), and are integrated into Rigid Wall Shelter Standardized Integrated Command Post Systems (RWS SICPS) mounted on M-1097 Vehicles, M1068 SICPS, and the C2V. PM ADCCS integrated all the equipment furnished as GFE from other Army Sources into the various TOC configurations.

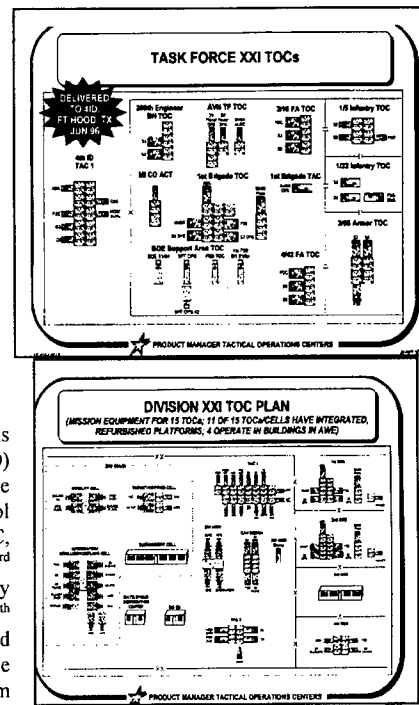

The DIV XXI TOCs represent an upgrade to the TF XXI TOCs for the Division XXI AWE to be conducted in November 1997. The purpose of the TOCS is to demonstrate the enhancements to Division Command and Control provided by Digitization through the use of Army Tactical Command and Control System (ATCCS) workstations and multiple communications devices. DIV XXI TOCs include: 4ID Division Command Group Vehicle; 4ID Tactical Alternate Command Post 1 (TAC 1) enhancement; 4ID Tac 2; 4ID Main Command Post, consisting of Mobility Cell, Targeting/Fires Cell, Information/Intelligence/Plans Cell, and Sustainment Cell; Battlefield Distribution Center; 4ID Division Artillery TOC; 1-10th Cavalry Squadron TOC; 124th Signal Battalion TOC and 2nd BDE TOC. Among other systems, DIV XXI TOCs FAAD, and Maneuver Control Ssystem (MCS) Workstations. Communications incorporated include with associated routers, switches, hubs, and other peripheral devices. DIV XXI TOCs incorporate AFATDS, CSSCS and ASAS RWS, and are integrated into RWS SICPS mounted on M-1097 Vehicles, M1068 SICPS, M-934 5-ton Expando Vans, and the C2V. due to a shortage of funds, the Sustainment Cell, Battlefield Distribution Center, 124th Signal Battalion TOC, were not integrated by PM TOC/AMCCS.

TRANSPORTATION CHARACTERISTICS / LIMITATIONS: All shelters and equipment are mounted on their own prime movers, either HMMWV, M-1068, M934A2, or C2V.

HISTORICAL BACKGROUND: TF XXI TOCs received funding in Jan 96 and delivered the TOCs in May-Aug 96. Based on experience with the TF XXI TOCs, PM ADCCS was given the task of integrating the DIV XXI TOCs. The design process began in 3QFY96.

REQUIREMENTS DOCUMENT: Requirements were developed as part of the Force XXI/DIV XXI process by 4ID, TPIO ABCS, PEO C3S FIO and PM ADCCS.

TYPE CLASSIFICATION: All TOCs were constructed as prototype, but will be left with 4ID after completion of the warfighting exercises except for the 1st Battalion 5th Infantry TOC.

EVENT SCHEDULE	FISCAL YEAR		97	98	99	00	01	02
	QTR		1 2 3 4	1 2 3 4	1 2 3 4	1 2 3 4	1 2 3 4	1 2 3 4
TF XXI Support Prototype TOCS			1 2					
TF XXI AWE			2					
DIV XXI Design Frozen			1					
Funds Received			2					
Integration			2 3					
Delivery			3 4					
Field Support			3	1				
Div AWE				1				

SYNOPSIS: TF/DIV XXI TOCS DEMONSTRATE ENHANCEMENTS TO DIVISION COMMAND AND CONTROL PROVIDED BY DIGITIZATION THROUGH THE USE OF ATCCS WORKSTATIONS AND MULTIPLE COMMUNICATIONS DEVICES FOR THE WARFIGHTING CAPABILITY OF THE 1ST BDE, 4ID.

PM, APPLIQUE

PM, APPLIQUE

APPLIQUE CONCEPT

APPLIQUE PROGRAM

PROJECT MANAGER: COL Dean Nakagawa, DSN 987-3237
COMM 732/427-3237

ACQUISITION CATEGORY: II
ACQUISITION PHASE: II Engineering & Manufacturing

PE & LINE #: Money provided by Army Digitization Office
Funds under PE 273758A D374

HARDWARE 

- Commercial (V1)
- Ruggedized (V2)
- Militarized (V3)
- Dismounted Soldier System
- Pos/Nav Device (PND)

SOFTWARE 

- Army Common Operating Environment
- Applications Reused from Other Gov't C2 Programs

INSTALLATION KITS 

- Tailored for Platform 

EMBEDDED SYSTEMS 

- Software Integrated into Embedded Computer

DESCRIPTION: The Applique Program is the centerpiece of the Army's efforts to digitize a Brigade-size experimental task force at Fort Hood by June 1996. Initially this program will consist of: over 1000 computers installed in Brigade Task Force vehicles and deployed with individual soldiers, software to support lower echelon battle command requirements, systems engineering, training and logistics support. The hardware consists of four basic computers: V1 is the commercial laptop version, V2 is the ruggedized version, V3 is the militarized version, and the Dismounted Soldier System Unit (DSSU) is the version for the soldier to carry which is also called a Pos/Nav Device (PND) when mounted in vehicles. The Applique System will interface with communications and electronic components installed on host platforms, and it will also interoperate with external command and control systems and digital systems embedded on other weapons platforms. Further development of computer hardware and software will follow the Brigade Task Force experiment scheduled for March 1997, at the National Training Center.

TRANSPORTATION CHARACTERISTICS / LIMITATIONS: None.

HISTORICAL BACKGROUND:

Aug 94 Solicitation issued.
Jan 95 Contract awarded to TRW.
Jul 97 MS I/II Decision Review.

REQUIREMENTS DOCUMENT: Force Battle Command Brigade and Below (FBCB2) User Functional Description, Jun 94. Horizontal Integration of Battle Command (HIBC) Mission Need Statement (MNS) was validated by JROC on 10 Jan 95. FBCB2 Operational Requirements Document (ORD) is at TRADOC. Key performance parameters to be refined prior to submission to JROC. Final ORD will be approved by 1 Nov FY97.

TYPE CLASSIFICATION: N/A.

RELEASEABLE TO SECURITY ASSISTANCE CUSTOMERS: No

EVENT SCHEDULE	FISCAL YEAR QTR	97		98		99		00		01		02	
		1	2	3	4	1	2	3	4	1	2	3	4
AWE		2	3										
MS I/II			4										
Field Test		2				2							
Limited User Test (LUT)			4										
FDTE						4							
IOTE						4							
MS III								1					
First Digitized Fielding									3				

SYNOPSIS: THE APPLIQUE SYSTEM IS AN EXPERIMENTAL BATTLEFIELD DIGITIZATION COMPUTER SYSTEM CONSISTING OF FOUR BASIC VERSIONS OF HARDWARE INSTALLED ON VEHICLES AND USED BY INDIVIDUAL SOLDIERS; CONNECTED BY A RADIO SYSTEM.

PM, ATCCS

PM, ATCCS

**COMMAND AND CONTROL VEHICLE (C2V)
MISSION MODULE SYSTEM (MMS)**

PROJECT MANAGER: COL Stanley C. Leja
DSN 992-4041
COMM 732/532-4041

PRODUCT MANAGER: Vacant
DSN 992-0380
COMM 732/532-0380

ACQUISITION CATEGORY: II
ACQUISITION PHASE: II

PE & LINE #: *

DESCRIPTION: The C2V MMS provides for Battle Staff operations (planning, coordination and execution) while on the move and at a quick halt. It houses various Battlefield Functional Area (BFA) hardware/software for the Battle Staffs in order to have a Command Post (CP) able to sustain mobility with Bradley and M1 tanks. It provides a universal electronic architecture that supports the Army Battle Command System (ABCS) with communications-electronics and ADP equipment presently in the inventory with a capability to incorporate future technology. It contains four operator seats, a 10-meter antenna mast for VHF radios, and a Local Area Network/Wide Area Network (LAN/WAN) capability.

The C2V MMS is a CP that will be used by maneuver forces to conduct commander/staff operations in heavy close combat providing C2 from corps through maneuver battalion. Initially, the C2V MMS was configured for CHS-1 equipment. Presently, there are interface for GPS, SINCGARS, IHFR, EPLRS, TACSAT, Vehicular Inter/Intra Communication System (VIICS) Network Radio (VNR), Thin Net IEEE 802.3 LAN, VIICS and non-VIICS intercoms, and external H-250 handsets. The voice and data communications interface capabilities are for six VHF radios, one each HF and SATCOM radio, four secure telephones, a radio/data network, and a robust CP intercom.

TRANSPORTATION CHARACTERISTICS / LIMITATIONS: C2V - C5 aircraft transportable only; overweight restrictions for trucking, height restrictions for rail transport.

HISTORICAL BACKGROUND:

Sep 94 Awarded C2V MMS contract.
Mar 97 Track CPs successfully participated in Task Force XXI exercise.

REQUIREMENTS DOCUMENT: Memorandum of Understanding between Program Executive Officer, Armored Systems Modernization and Program Executive Officer Command and Control Systems, May 92, subject: Command and Control Vehicle (C2V) Development.

TYPE CLASSIFICATION: N/A

RELEASEABLE TO SECURITY ASSISTANCE CUSTOMERS: No

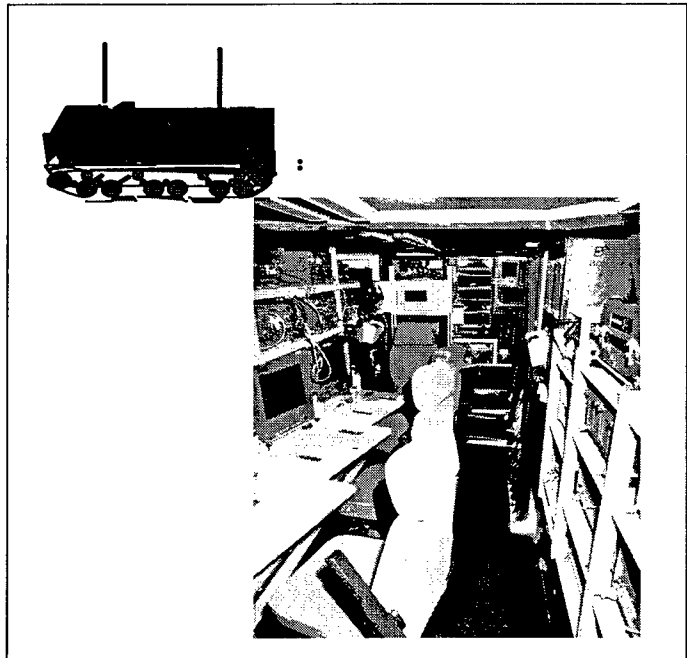

SYNOPSIS: THE C2V MMS IS A CP THAT WILL BE USED BY MANEUVER FORCES TO CONDUCT COMMANDER/STAFF OPERATIONS IN HEAVY CLOSE COMBAT PROVIDING COMMAND AND CONTROL FROM CORPS THROUGH MANEUVER BATTALION. THE C2V MISSION MODULE WILL CONSIST OF RACKS, WIRING AND HARNESSSES TO INTERFACE WITH EXISTING ABCS EQUIPMENT AND WILL ADAPT TO FUTURE C4I TECHNOLOGIES.

PM, ATCCS

COMMON HARDWARE SYSTEMS (CHS)

PROJECT MGR: COL Stanley Leja,
DSN 992-4041
COMM 732/427-4679

PRODUCT MANAGER: LTC Gabriel Leyva,
DSN 987-2063
COMM 732/427-2063

ACQUISITION CATEGORY: II
ACQUISITION PHASE: III

PE & LINE #: 6.48.18A (D323) AEW17P03

DESCRIPTION: The CHS program procures/provides standard common hardware/software to the Army Battle Command System (ABCS) Battlefield Functional Area (BFA) programs for use in their system development and fielding. The PM develops and acquires the common products that will provide the Army with Command and Control (C2) automatic data processing capabilities designed to improve the effectiveness of the ABCS. The PM also provides these products to other Department of Defense (DOD) organizations, when required. Additionally, the PM manages the design, development, analysis, production and engineering efforts for these products to ensure that they meet their stated requirements and program objectives. The CHS program includes a wide range of commercial and rugged computers from handheld devices to high-end Reduced Instruction Set Computer (RISC) based work-stations. These are complimented by a wide variety of peripherals; including many types of storage devices, printers, displays, communications devices, etc. These products have been designed, field tested and environmentally qualified for use in wheel and track vehicles, shelters, and tents. Procured items: NDI computers to include a Handheld Terminal unit (HTU), Transportable Computer Unit (TCU), High Capacity Computer Unit (HCU), and comparable NDI peripheral devices. All, but the HTU, will be provided as a V1 version similar to commercial models or as a ruggedized V2 version. Procured commercial software includes: operating systems, graphics, database management systems, word processing, spreadsheets, communications, training, and maintenance diagnostic programs.

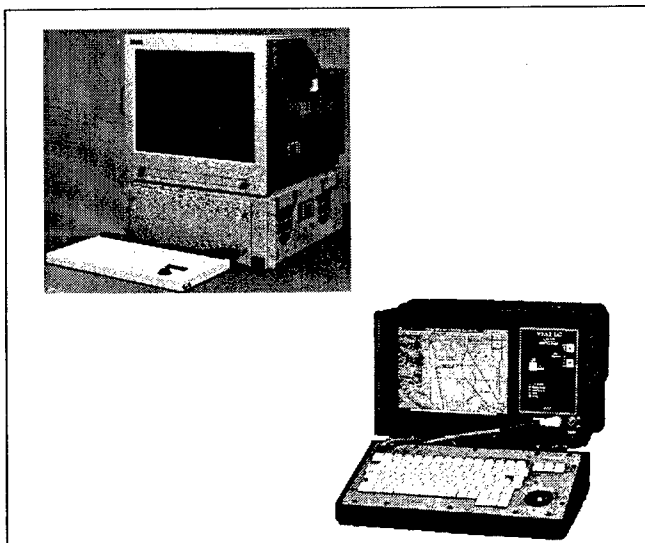

LIGHTWEIGHT COMPUTER UNIT (LCU) - The LCU is a lightweight computer system for use in applications requiring smaller size, less weight & limited graphic capabilities. The LCU is an NDI procurement similar to CHS 1 & interoperates with existing CHS systems. The Tactical Communications interface Module (TCIM) is also procured under the LCU program. The TCIM allows interface to tactical radios.

CHS-2 - The DoD agencies can procure an interoperate family of modular building block of NDI workstations and peripherals in commercial and ruggedized versions. Also included are Commercial Off-The-Shelf (COTS) software Programming Support Environment, Programmatic Support, maintenance, Time-and-Materials for technical assistance and support services and Training.

TRANSPORTATION CHARACTERISTICS / LIMITATIONS: N/A

HISTORICAL BACKGROUND:

Jun 87 Program provisionally established.
Aug 88 Awarded CHS-1 contract.
May 91 Awarded LCU contract; Initial delivery of V2 (LCU).
Apr 95 Awarded CHS-2 contract.

REQUIREMENTS DOCUMENT: Original ROC, Dec 86. ABCS updated ROC Sep 90 to include LCU. ABCS updated ROC, Sept 92 to include CHS-2.

TYPE CLASSIFICATION: Not separately Type Classified.

RELEASEABLE TO SECURITY ASSISTANCE CUSTOMERS: No

SYNOPSIS: THE CHS PROGRAM EQUIPS THE ABCS BFAs FROM ECHELONS ABOVE CORPS TO FOXHOLE WITH COMPATIBLE NDI COMPUTERS, SOFTWARE, PERIPHERALS, PROGRAMMING SUPPORT ENVIRONMENT. ETC., AS WELL AS TECHNICAL ASSISTANCE AND COMMON LOGISTICS SUPPORT.

PM, ATCCS

COMMON SOFTWARE SYSTEMS

PROJECT MANAGER: COL Stanley C. Leja,
DSN 992-4041
COMM 732/532-4041

PRODUCT MANAGER: Dr. David Usechak,
DSN 987-3840
COMM 732/427-3840

ACQUISITION CATEGORY: II
ACQUISITION PHASE: III

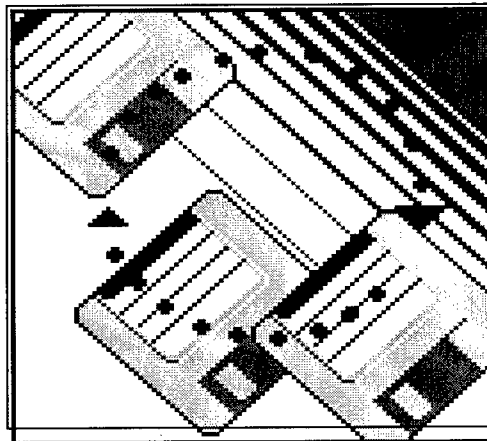

PE & LINE #: 6.48.18A (D323) AEW17P03

DESCRIPTION: The Common Software program is based upon a wide variety of Commercial Off-the-Shelf (COTS) products; e.g., operating systems, DataBase Management Systems (DBMSs), Graphical, Integrated Business Package, Networking, communications products, etc. Common Software products are supported by a robust, modular, and integrated suite of Program Support Environment hardware/software to help a program or system developer in the implementation of their respective system. Additionally, the common software program develops and integrates common support and applications software for reuse by Department of Defense (DOD) agencies. The development of these products is consistent with the U. S. Army's Software Reuse Policy and the DOD "Software Reuse Vision and Strategy" and in accordance with the Defense Information Infrastructure Common Operating Environment (DII COE) architecture. The common software products are being integrated into the DII COE. The Product Manager also represents the Army as the agent for the Defense Information Systems Agency (DISA) in developing components of the DII COE to include message processing, alerts and data access.

COMMON OPERATING ENVIRONMENT (COE) - The DII COE emphasizes both software reuse and interoperability, using a "plug and play" open architecture designed around a client/server model. The COE architectural concept provides the capability to leverage a mature, proven, field tested software based for a wide variety of applications. This is based upon state-of-the-art software technology and standards. The COE and associated common software applications are supported by the CHS computer platform for use by all Army Battle Command Systems.

COMMON APPLICATIONS (CA) - Develop, test and integrate CA based upon a client/server architecture using Open Systems Foundation Distributed Computing Environment (DCE). These products were developed in accordance with the U. S. Army Technical Architecture, the Army Software Reuse Policy and the DOD Software Reuse Vision and Strategy.

TRANSPORTATION CHARACTERISTICS / LIMITATIONS: N/A

HISTORICAL BACKGROUND:

Nov 90 Program provisionally established.
Oct 92 CASS Release 0.4 delivery.

REQUIREMENTS DOCUMENT: N/A

TYPE CLASSIFICATION: N/A

RELEASEABLE TO SECURITY ASSISTANCE CUSTOMERS: No

SYNOPSIS: THE COMMON SOFTWARE PROGRAM INTEGRATES A WIDE VARIETY OF DII COE COMPATIBLE AND COMPLIANT PRODUCTS AND FOCUSES ON VALIDATING THE IMPLEMENTATION OF USER REQUIREMENTS. THE PROGRAM CONSISTS OF TWO MAJOR SOFTWARE REUSE INITIATIVES THAT WILL IMPROVE INTEROPERABILITY, HELP ENSURE CONSISTENCY OF OPERATIONS ACROSS THE BATTLEFIELD AND RESULT IN ACQUISITION STREAMLINING AND MAINTENANCE COST SAVINGS.

PM, ATCCS

MANEUVER CONTROL SYSTEM (MCS)

PROJECT MANAGER: COL Stanley C. Leja, DSN 992-4041
 COMM 732/532-4041
 FAX: DSN 992-6388 COMM: 732/532-6388
 E-Mail: leja@doim6.monmouth.army.mil

ACQUISITION CATEGORY: ID
ACQUISITION PHASE: MS II Eng/Manufacturing Dev

PE & LINE #: 273740.D484 SSN: BA-9320
 273740.D2HT BA-9710
 BS-9710

DESCRIPTION: MCS software products provide the heart of the Army Battle Command System (ABCS). MCS is a tactical information and computer network utilizing a client-server architecture with a distributed database to automate the command and control process. Field commanders and staffs are provided the capability to receive, access and process information, rapidly disseminate decisions and orders, and react inside the enemy's decision cycle. MCS computers operate at Corps through maneuver battalion. MCS provides the analysis tools to allow tactical planners the ability to shift and concentrate combat power in conjunction with other friendly forces. Tactical battlefield information which can be readily accessed and graphically displayed include friendly and enemy unit activity on an electronic map background, unit task organization (using standard symbology), and unit readiness status. MCS interfaces to standard Army tactical communications (secure/non-secure, wire and radio) such as the Mobile Subscriber Equipment (MSE) and the Combat Net Radio Systems. It interoperates with other Army, joint and combined C2 systems. MCS software runs on the Army's CHS. The primary components of MCS are the software applications which directly support the commanders and staff. MCS reuses the DII Common Operating Environment and is compliant with the Army Technical Architecture (ATA) and Joint Technical Architecture (JTA).

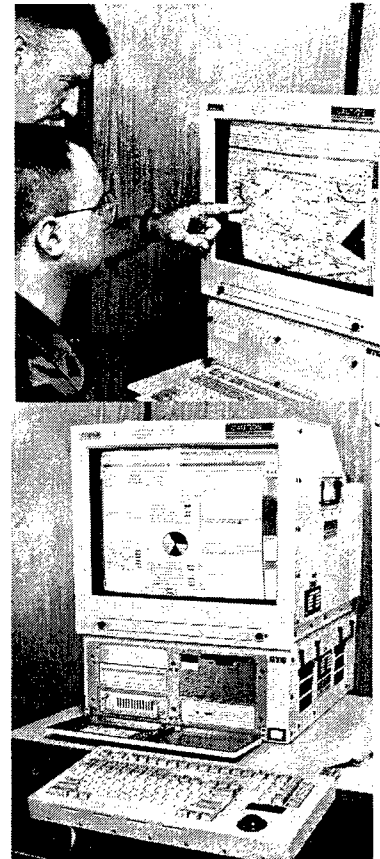

TRANSPORTATION CHARACTERISTICS / LIMITATIONS: Computer Set, Digital AN/TYQ-45A(V2); H: 43.80, W: 66.75, L: 77.0, Wt. 231 lbs.

HISTORICAL BACKGROUND:

- Late 1980's MCS V10 fielded on TCP&AC.
- Feb 93 Rebaselined Program to be on Common Software foundation.
- Aug 94 Integrated Interoperability Demo at Ft. Hood.
- Sep 96 Block IV contract awarded.
- Mar 97 MCS Version 12.01 used in TF XXI.
- May 97 Successful operational assessment using MCS TF XXI software.

REQUIREMENTS DOCUMENT: ORD Nov 95.

TYPE CLASSIFICATION: TCP, AN/UYQ-43(V)1 and AC, AN/UYQ(V)2 type classification Standard, at IPR, Jun 86. Transitioned to CECOM 1QFY93. AN/TYQ-45 to be type classified standard after MSIII Decision.

RELEASEABLE TO SECURITY ASSISTANCE CUSTOMERS: Yes

EVENT SCHEDULE	FISCAL YEAR																							
	97				98				99				00				01				02			
	1	2	3	4	1	2	3	4	1	2	3	4	1	2	3	4	1	2	3	4	1	2	3	4
V. 12.01 LUT	1																							
V. 12.01 IOTE						3																		
V. 12.01 MS III DAB										1														
V. 12.1 OA/OT										2														
V. 12.2 OA/OT											2													
V. 12.3 OA/OT															2									

SYNOPSIS: MCS IS THE HEART OF THE ARMY BATTLE COMMAND SYSTEM (ABCS) AND DIGITIZES BATTLE COMMAND FUNCTIONS FOR THE MANEUVER COMMANDER AND HIS STAFFS INSIDE CORPS TO BATTALION TACTICAL OPERATIONS CENTERS.

PM, ATCCS

STANDARD INTEGRATED COMMAND POST SYSTEM (SICPS)

PROJECT MANAGER: COL Stanley C. Leja.
DSN 992-4041
COMM 732/532-4041

PRODUCT MANAGER: Vacant
DSN 992-0380
COMM 732/532-0380

ACQUISITION CATEGORY: III
ACQUISITION PHASE: III

PE & LINE #: BZ9962 (OPA)

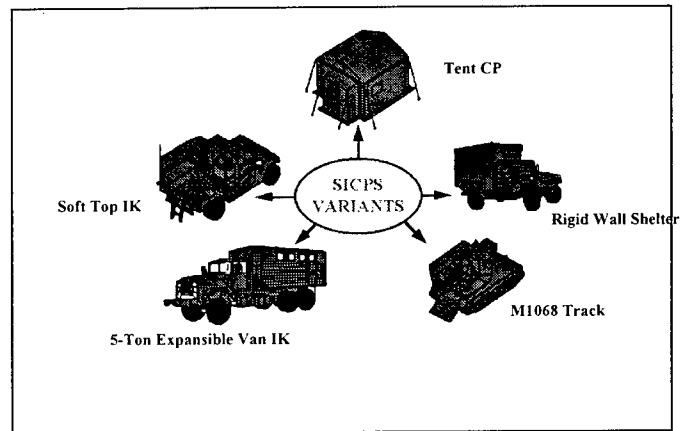

DESCRIPTION: The SICPS provides the Army Battle Command System (ABCS) nodal Project Managers with a family of standard hardware command post (CP) facilities to house ABCS across all Battlefield Functional Areas (BFAs). Variants of the SICPS consist of a Tent CP, a Rigid Wall Shelter (RWS) CP, a Track Vehicle CP (M1068), a 5-Ton Expansive Van CP and a Soft Top CP. These platforms provide power, environmental control, mounting hardware, lights, and grounding kits. When populated with common hardware/software and communications equipment, these systems provide the capability to operate a survivable and mobile CP.

TENT CP - The tent consists of a three-piece lightweight aluminum frame (11ft X 11ft) with interchangeable fabric sidewalls, any of which can be removed for attaching two or more tents together. Fielded with two work tables, mapboards and a fluorescent light set, the Tent CP can be attached to any of the other SICPS variants, except the 5-Ton Expansive Van CP, by replacing one sidewall with an interface boot wall.

RWS CP - The RWS is lightweight, transportable, protected against electromagnetic/environmental effects as well as from chemical and biological agents, and mounts on a Heavy High Mobility Multipurpose Wheeled Vehicle (HMMWV). It provides equipment racks, workspace for two workstations and operators as well as a mounted swivel chair for operation on the move.

5-TON CP - The 5-Ton is an installation kit that is installed in an expandable van and provides four movable workstation racks and workspace for four operators. It consists of a power and signal entrance box, AC/DC power distribution boxes, DC power supply, two map boards, Quick Erect Antenna Mast (QEAM), four antenna mounts, internal lighting and wiring, blackout provision, two communications racks, patch panel rack, cable ducts, LAN group, fiber optic group, Surface Wire Grounding System (SWGS), two vehicle boarding ladders, and a storage container.

SOFT TOP CP - The Soft Top is an installation kit that is installed on the back of a HMMWV. It provides equipment racks and workspace for two workstations and operators. All kit components are attached to the vehicle using hardware provided with the kit. It is comprised of standard electrical and mechanical components to include a blackout cargo cover longer, Power Control Module, Communications Entry Panel, Workstation Data Module, power distribution/extension boxes, adjustable metal equipment racks, two table assemblies, two chairs, wiring harnesses, cables, internal lighting system, blackout provision, antenna support base, QEAM, floor plate, SWGS, vehicle boarding ladder and a storage drawer.

M1068 CP - The M1068 is a modified 577 track vehicle. It provides equipment racks and workspace for two workstations and operators. It consists of a 5kw on-board generator, intercom system, QEAM, six antenna mounts, internal lighting and wiring, signal panel, power distribution panel, SWGS, and storage provisions.

TRANSPORTATION CHARACTERISTICS / LIMITATIONS: N/A

HISTORICAL BACKGROUND:

Aug 91 . Awarded Ten CP contract.
Sep 91 . Awarded RWS V1 contract.
Jun 92 . Awarded Track CP contract.
Jun 95 . Awarded Soft-Top CP contract.
Aug 96 . Awarded RWS V4 contract.
May 97 . Awarded 5-ton CP contract.

REQUIREMENTS DOCUMENT: Basic SICPS ROC, Jul 87. Each platform has an annex to basic ROC.

TYPE CLASSIFICATION: Tent TC Standard; RWS V1 TC Standard; RWS V4 TC Generic; Track TC Standard; Soft-Top TC Standard; 5-Ton TC LP.

RELEASEABLE TO SECURITY ASSISTANCE CUSTOMERS: Yes

SYNOPSIS: THE SICPS PROVIDES STANDARD PLATFORMS, TECHNICAL ASSISTANCE AND COMMON LOGISTICS SUPPORT. IT IS DESIGNED FOR QUICK EMBLACEMENT AND DISPLACEMENT ON THE BATTLEFIELD. ALSO, THE COMMONALITY OF THE SICPS DESIGN DIMINISHES THE ENEMY'S ABILITY TO IDENTIFY THE TACTICAL UNIT TYPE.

PD, CNCMS

PM, CNCMS

COUNTERNARCOTICS COMMAND AND MANAGEMENT SYSTEM (CNCMS)

PROJECT DIRECTOR: LTC J.P. Kimmel,
 DSN 235-8115
 COMM 703/275-8115
 FAX: 703/275-8116
 E-Mail: jkimmel@asaspmo.belvoir.army.mil

ACQUISITION CATEGORY: III
ACQUISITION PHASE: MS III Production/Deployment

PE & LINE #:

DESCRIPTION: The Counternarcotics Command and Management System (CNCMS) is the U.S. Southern Command (USSouthCom) Commander-in-Chief's principal command and control system supporting the Command's primary missions of nation building and counterdrug operations, providing secure voice, imagery and data connectivity between the National Capital Region, USSouthCom Headquarters and Embassy Country Teams executing counterdrug operations throughout Latin America and the Caribbean. The CNCMS is interoperable with the Defense Information Systems Agency's Anti-Drug Network (ADNET) and the Drug Enforcement Administration's MERLIN system.

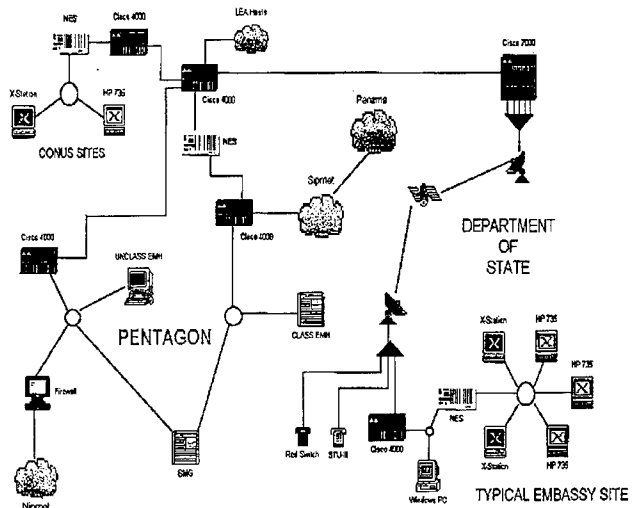

TRANSPORTATION CHARACTERISTICS / LIMITATIONS: Strategic fixed secure communications and ADP capability. Tactical man-portable secure communications and ADP capability also provided.

HISTORICAL BACKGROUND:

- May 90 ROC 1-90 approved by Joint Staff.
- Dec 90 First prototype site installation.
- Sep 91 System implementation transferred to PM CNCMS.
- Sep 91 Joint Staff J6 directed transition to Open System Architecture.
- Sep 94 System fully transitioned to OSA.
- Dec 95 Connectivity to the SIPRNET established.
- Aug 96 Implemented Multi-Level Information Security Architecture.
- Oct 96 Achieved COE runtime compliance level 5 (Minimal COE).
- Aug 97 Began fielding NT based systems.

REQUIREMENTS DOCUMENT: USCINCSOUTH RS 1-90 approved May 90.

TYPE CLASSIFICATION: Secret.

RELEASEABLE TO SECURITY ASSISTANCE CUSTOMERS: Yes

EVENT SCHEDULE	FISCAL YEAR	97				98				99				00				01				02			
		QTR				QTR				QTR				QTR				QTR				QTR			
Software Build 5.0		1																							
3 Site Installations		3																							
8 Installations in support of SouthCom HQ's relocation		4																							
30 Caribbean Site Installations		4																							
Software Build 6.0						2																			
Program Transition						4																			

SYNOPSIS: CNCMS IS A SECRET VOICE AND DATA C3I SYSTEM SUPPORTING US SOUTHERN COMMAND AND CERTAIN DESIGNATED FEDERAL DRUG LAW ENFORCEMENT AGENCIES.

PM, FATDS

PM, FATDS

ADVANCED FIELD ARTILLERY TACTICAL DATA SYSTEM (AFATDS)

PROJECT OFFICER: LTC William Drummond,
 DSN 987-3328
 COMM 732/427-3328
 FAX: 732/542-3322
 E-Mail: drummond@doim6.monmouth.army.mil

ACQUISITION CATEGORY: IC
ACQUISITION PHASE: MS III Production

PE & LINE #: 1B423.726D322

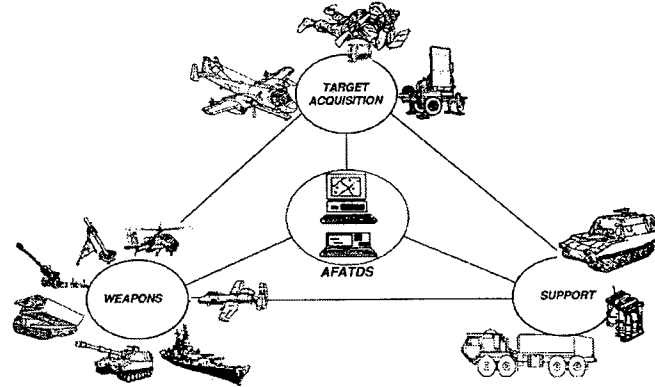

DESCRIPTION: The Advanced Field Artillery Tactical Data System (AFATDS) is a multi-service (Army and Marine Corps) digitized and integrated fire support battlefield management and decision support system which satisfies the fire support requirements of the Army operations doctrine. AFATDS provides integrated, automated support for the planning, coordination and control of all fire support assets (artillery, mortars, close air support, Multi Launch Rocket System, naval gunfire, attack helicopter and offensive electronic warfare) execution of counterfire interdiction and suppression of enemy targets. AFATDS will function from battery through echelons above Corps as the Fire Support node of the Army Tactical Command and Control System (ATCCS) and the Army Battle Command System (ABCS) utilizing the Common Operating Environment (COE) architecture. AFATDS is designed to overcome the vulnerability, limited functionality, central processing and training limitations of present artillery battalion, brigade, division and corps fire direction systems. AFATDS will take advantage of advancing software technology, graphics, decision aids, and embedded training to expand the Fire Support functions. As the Fire Support node of the ABCS, AFATDS will provide advanced software automation assistance to the Fire Support elements and will interface with all subsystems subordinate to AFATDS and other nodes of ABCS via the standard communications media available to the force. AFATDS will provide 27 fire support functions, grouped in five Fire Support operational needs (Fire Support Execution, Fire Support Planning, Movement Control, Field Artillery Mission Support and Field Artillery Fire Direction Operations). AFATDS will interface/interoperate via standard communications media with all functional control elements of existing and future Army Fire Support Systems, other ABCS Battlefield Functional Area (BFA) Systems, other services employing Fire Support Joint Interoperability Tactical Command and Control Systems message standards and Allied Forces using NATO Fire Support Standards. AFATDS also provides proven fire control for Air Force and Naval assets as well as Army and Marine ground forces. The Air Force capability is met by integration with the Contingency Theater Air Planning System (CTAPS) and the Navy requirement is met via integration with the Naval Joint Maritime Combat Information System (JMCIS).

TRANSPORTATION CHARACTERISTICS / LIMITATIONS: AFATDS may be transported in the following configurations: M1068 Command Post; SICPS Rigid Wall Shelter; 5 ton Expandible van; SICPS soft top.

HISTORICAL BACKGROUND:

- | | | | |
|--------|--|--------|--|
| Apr 90 | Full Scale Development - Version 1 contract award. | Jul 96 | Blue Flag Exercise. |
| Oct 92 | Version 2 Option Exercised. | Sep 96 | Southwest Asia Activities. |
| Feb 94 | FDTE I completed. | Dec 96 | A96 Materiel Release. |
| Jun 95 | FDTE II (735) completed. | Jan 97 | A96 Initial Operational Capability (IOC). |
| Sep 95 | IOTE Completed. | Apr 97 | A99 Version Q.1 Option Exercised. |
| Nov 95 | Type Classified Standard. | Aug 97 | A97 Technical Test Readiness Review (TTRR) CHS I/II. |
| Dec 95 | ASARC III Production Decision. | | |
| May 96 | Combined Joint Task Force Exercise (CJTFFEX). | | |
| May 96 | Joint Warrior Interoperability Demo (JWID 96). | | |

REQUIREMENTS DOCUMENT: AFATDS revised ORD, 28 Sep 93, AFATDS TEMP dated 3 Aug 95.

TYPE CLASSIFICATION:

RELEASEABLE TO SECURITY ASSISTANCE CUSTOMERS: Yes

EVENT SCHEDULE	FISCAL YEAR QTR	97			98			99			00			01			02				
		1	2	3	4	1	2	3	4	1	2	3	4	1	2	3	4	1	2	3	4
Field AFATDS 96 Software		2																			
Field AFATDS 97 Software						2															
Field AFATDS 98 Software								2													
Field AFATDS 99 Software									2												
Field AFATDS 00 Software													2								

SYNOPSIS: AFATDS WILL BROADEN & MODERNIZE THE US ARMY FIRE SUPPORT COMMAND, CONTROL & COORDINATION (FSC3) SYSTEM.

PM, FATDS

FIRE SUPPORT ADA CONVERSION (FSAC)

PROJECT LEADER: Jim Cafiero,
DSN 992-5226
COMM 732/532-5226
FAX: 732/427-3322
E-Mail: cafiero@doim6.monmouth.army.mil

ACQUISITION CATEGORY: III
ACQUISITION PHASE: MS III Production/Deployment

PE & LINE: B78400

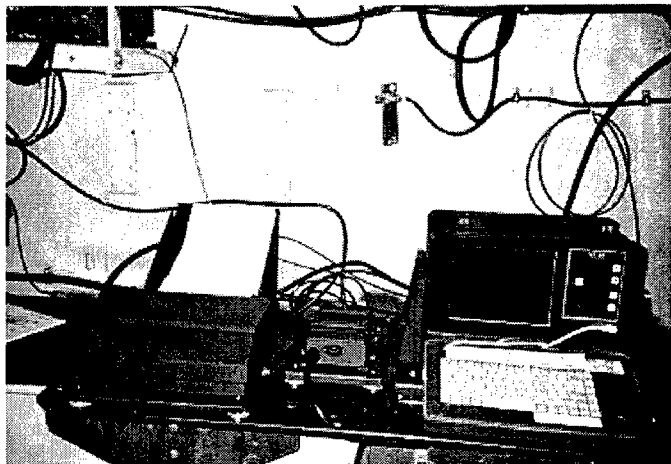

DESCRIPTION: The Fire Support Ada Conversion Program replaced the aging Field Artillery fire direction Battery Computer Units (BCUs) with modern Army Tactical Command and Control System (ATCCS) Lightweight Computer Units (LCUs) (known as the AN/GYK-37(V)1). The BCU is used in the Battery Computer System (BCS) for cannon-equipped artillery batteries and the Fire Direction System (FDS) for Multiple Launch Rocket Systems (MLRS) units. The existing software, written in Symbolic Interpreter Routine, was rewritten in the DoD standard Ada language. Initial fieldings of the BCS and FDS were deployed with an emulator version software and were upgraded with the Ada versions in FY94. The FSAC systems will be upgraded with Package 11 software and 1.2 Gb hard disk drives in FY99.

TRANSPORTATION CHARACTERISTICS / LIMITATIONS: None.

HISTORICAL BACKGROUND:

<u>MLRS</u>	<u>BCS</u>	
Feb 89	Feb 90	Program Start.
Aug 90	Jul 91	Critical Design Review.
Oct 91	Jan 92	Formal Qualification Test.
Mar 92	---	IOT&E.
Jul 92	Jul 92	Production Decision.
Jan 93	Nov 92	FUE.
	Jul 94	FUE BCS ADA.
	Dec 94	Completed BCS ADA IOTE (PKG 10).
	Apr 95	Funding authority given to use FSAC funding line for LFED program.

REQUIREMENTS DOCUMENT: ROC approved 12 Oct 90 (as part of Battery computer Unit ADA Conversion).

TYPE CLASSIFICATION: Jul 92.

RELEASEABLE TO SECURITY ASSISTANCE CUSTOMERS: Yes

<u>EVENT SCHEDULE</u>	<u>FISCAL YEAR</u>		97	98	99	00	01	02
	<u>QTR</u>		1 2 3 4	1 2 3 4	1 2 3 4	1 2 3 4	1 2 3 4	1 2 3 4
BCS ADA IOTE (Pkg 11)				2				
FDS ADA IOTE (Pkg 11)				2				
BCS ADA (Pkg 11) FUE					2			
FDS ADA (Pkg 11) FUE					2			

SYNOPSIS: FSAC WAS ESTABLISHED TO PROVIDE FOCAL POINTS FOR THE MANAGEMENT OF BCS AND MLRS FDS.

PM, FATDS

FORWARD ENTRY DEVICE (FED)

PROJECT LEADER: Jeff Weiss,
DSN 987-3365
COMM 732/427-3365
FAX: 732/427-3322
E-Mail: weiss@doim6.monmouth.army.mil

ACQUISITION CATEGORY: III
ACQUISITION PHASE: MSIII Production/Deployment

PE & LINE #: BZ9851



DESCRIPTION: The Forward Entry Device (FED) is used in the Heavy Divisions by the Forward Observer (FO), Field Artillery (FA) Battery Commanders and Fire Support Team (FIST) personnel. The current FED consists of Forward Observer Command and Control (FOCC) and Meteorological Survey (MET) software on a SHTU which enables the user to plan, control, and execute fire support operations at maneuver platoon, company battalion, and brigade levels. The FED was transitioned to CECOM for level II management in Feb 94. In order to support the new digital messages in MIL-STD-188-220, CECOM planned to upgrade the SHTU based FED. Failure to upgrade the device would have rendered it obsolete in FY99 when the fire support package 11 is fielded. The SHTU replacement, the Handheld Terminal Unit (HTU), is the same hardware that will be used for the Lightweight Forward Entry Device (LFED). The HTU is a militarized handheld device procured from the Common Hardware/Software II contract. During the transition of the FED, the LFED had remained under PM FATDS management control. The FED and LFED will be fielded with FOCC software and upgraded with the Forward Operating System (FOS) software when available. Since the FED will utilize the same hardware (HTU) and software (FOS) as the LFED, the programs will be combined into one program. Therefore, In Oct 96 ODCSOPS reassigned the FED program from CECOM to PM FATDS. The FED replacement ensures continued Heavy Division Digital Communications to call for fire support utilizing the Forward Operating System (FOS) software.

TRANSPORTATION CHARACTERISTICS / LIMITATIONS: None.

HISTORICAL BACKGROUND:

Sep 93 Annex G, AFATDS ORD.
Feb 94 FED transitioned to CECOM.
Oct 96 ODCSOPS reassigned FED program to PM FATDS to be combined with the existing LFED program.

REQUIREMENTS DOCUMENT: AFATDS ORD.

TYPE CLASSIFICATION:

RELEASEABLE TO SECURITY ASSISTANCE CUSTOMERS: Yes

<u>EVENT SCHEDULE</u>	<u>FISCAL YEAR</u>		97	98	99	00	01	02
	<u>QTR</u>		1 2 3 4	1 2 3 4	1 2 3 4	1 2 3 4	1 2 3 4	1 2 3 4
IOT&E Pkg 11				2				
FUE Pkg 11					2			

SYNOPSIS: THE FED IS A HANDHELD TERMINAL UNIT HOSTING THE FORWARD OBSERVER SOFTWARE FOR USE BY THE HEAVY DIVISIONS.

PM, FATDS

**INITIAL FIRE SUPPORT AUTOMATED SYSTEM
(IFSAS)**

PRODUCT LEADER: Jim Cafiero,
DSN 992-5226
COMM 732/532-5226
FAX: 732/427-3322
E-Mail: cafiero@doim6.monmouth.army.mil

ACQUISITION CATEGORY: III
ACQUISITION PHASE: MS III Production/Deployment

PE & LINE #: B78100

DESCRIPTION: The IFSAS is designed to provide limited automation of Fire Support Command and Control at battalion nodes and above. The system gives commanders the ability to perform automated fire support planning and execution prior to the arrival of the AFATDS. The system utilizes the ATCCS CHS LCU and has been fielded to both active and NG/Reserve units to provide early automation capabilities.

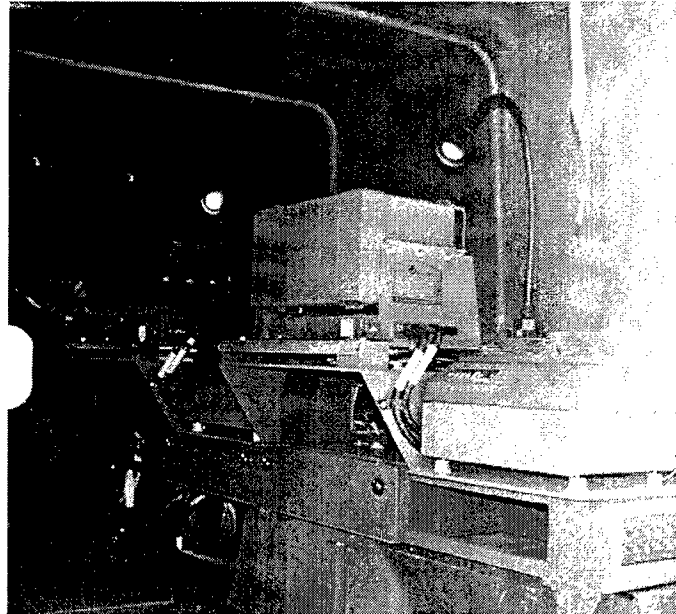

TRANSPORTATION CHARACTERISTICS / LIMITATIONS: None.

HISTORICAL BACKGROUND:

Aug 91 Program Approval.
Dec 92-Jan 93 System comparison contractor selection.
Mar 93-May 93 Pkg 10 Operational Test.
Jul 93 Milestone III Approval.
Aug 93 FUE NG.

REQUIREMENTS DOCUMENT: DCSOPS msg, Jan 93, IFSAS Requirements Determination.

TYPE CLASSIFICATION: MS III Approval - 12 Jul 93, Type Class - Jul 93.

RELEASEABLE TO SECURITY ASSISTANCE CUSTOMERS: No

<u>EVENT SCHEDULE</u>	<u>FISCAL YEAR</u>						
	97	98	99	00	01	02	
	1 2 3 4	1 2 3 4	1 2 3 4	1 2 3 4	1 2 3 4	1 2 3 4	
IFSAS Pkg 11 IOT&E		2					
First Unit Equipped (FUE) with Pkg 11 Software			2				

SYNOPSIS: IFSAS PROVIDES AN INITIAL MODERN CAPABILITY TO BOTH THE ACTIVE ARMY (AA) AND NATIONAL GUARD (NG) FORCES.

PM, FATDS

LIGHTWEIGHT FORWARD ENTRY DEVICE (LFED)

PROJECT LEADER: Jeff Weiss.
DSN 992-3365
COMM 732/427-3365
FAX: 732/427-3322
E-Mail: weiss@doim6.monmouth.army.mil

ACQUISITION CATEGORY: III
ACQUISITION PHASE: Production/Deployment

PE & LINE #: B78400



DESCRIPTION: The LFED is used by Forward Observers to compare, edit, transmit, receive, store, display messages and process the data used to conduct Fire Support Operations. It is a militarized handheld device utilizing the handheld terminal unit on the Common Hardware/Software II contract. The LFED and Forward Entry Device (FED) Program will be combined under one funding line in the near future.

TRANSPORTATION CHARACTERISTICS / LIMITATIONS: None.

HISTORICAL BACKGROUND:

Sep 93 Annex G, AFATDS ORD.
Apr 95 Funding authority to use FSAC funding line.

REQUIREMENTS DOCUMENT: AFATDS ORD

TYPE CLASSIFICATION:

RELEASEABLE TO SECURITY ASSISTANCE CUSTOMERS: Yes

<u>EVENT SCHEDULE</u>	<u>FISCAL YEAR</u>																							
	97				98				99				00				01				02			
	<u>QTR</u>				<u>QTR</u>				<u>QTR</u>				<u>QTR</u>				<u>QTR</u>				<u>QTR</u>			
FUE Pkg 10	2-----				-----3																			
IOT&E Pkg 11					2																			
FUE Pkg 11									2															

SYNOPSIS: THE LFED IS A HANDHELD TERMINAL UNIT HOSTING THE FORWARD OBSERVER SOFTWARE FOR USE BY THE LIGHT INFANTRY DIVISIONS.

PM, INTEL FUSION

PM, INTELLIGENCE FUSION

PROJECT MANAGER: COL Lawrence G. J. Arrol
DSN: 235-8110
COMM: 703/275-8110
FAX: DSN 235-8251
E-Mail: larrol@asaspmo.belvoir.army.mil

DESCRIPTION: The Project Manager Intelligence Fusion family of products offers automated intelligence support systems designed to serve intelligence operators and Joint Warfighters across the spectrum of conflict. Additionally, Intelligence Fusion products support decision makers at theater and above, Joint Task Force, corps, division, separate brigade, armored cavalry regiment, ranger regiment, special forces group, aviation brigade, and maneuver brigade/battalion and all use Intelligence Fusion systems.

The Intelligence Fusion Project is an umbrella program that provides the services with no means to focus and synchronize several of the diverse intelligence development efforts into as many common elements as possible, thus conserving resources. It does this through the integration of the following Military Intelligence (MI) functions: Intelligence Preparation of the Battlefield (IPB), collection management, all source and single source intelligence analysis and fusion, imagery management, target development, asset technical control, battle damage assessment, weather effects, counter intelligence/human intelligence (CI/HUMINT), and force protection. These functions are then translated into the following Products: All Source Analysis System (ASAS), CI/HUMINT Management System (CHIMS), Integrated Meteorological System (IMETS), Single Source Processor-SIGINT (SSP-S), and Joint Collection Management Tools (JCMT). Intelligence systems interoperability between national agencies, other services, Allied, combined, coalition forces, and the Army is a primary concern of the Intelligence Fusion Office. The Modern Information Data Base (MIDB), Imagery Product Library (IPL), Defense Counter-Intelligence Support System (DCISS) products as well as Joint Maritime Combat Information System (JMCIS) and Combat Information System (CIS) are interoperability targets.

The PM provides overall direction and guidance for the development, testing, acquisition, product improvement, rapid prototyping, and fielding of assigned programs. Each of the assigned programs share a common acquisition and support strategy that conserves resources while allowing for continuous growth through technology insertion at reduced risk. The PM Intelligence Fusion performs as the Army's centralized manager for assigned programs and reports directly to the Program Executive Officer Command, Control, and Communications Systems.

SYNOPSIS: CENTRALIZED MANAGEMENT FACILITIES SOFTWARE REUSE, SHARING FUNCTIONALITIES, TECHNOLOGY INSERTION, AND AFFORDS CONTINUOUS GROWTH WITH LOW RISK AND REDUCED COSTS.

PM, INTELLIGENCE FUSION

ALL SOURCE ANALYSIS SYSTEM (ASAS)

PROJECT MANAGER: LTC Gregory Fritz,
 DSN 235-8110
 COMM 703/275-8110
 FAX: DSN 235-8251
 E-Mail: fritzg@asaspmo.belvoir.army.mil

ACQUISITION CATEGORY: I (C)
ACQUISITION PHASE: MS II Eng/Manufacturing Dev

PE & LINE #: RDTE 64321.B19 ASAS Evolutionary Acq
 OPA K28801 ASAS-Modules (TIARA)

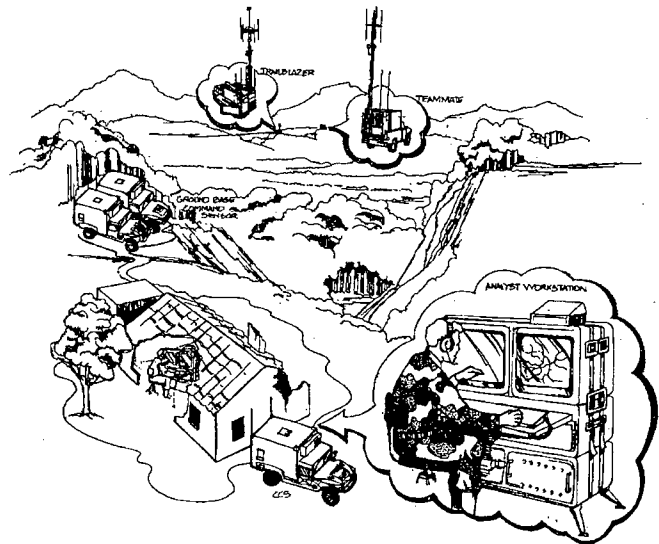

DESCRIPTION: ASAS is the Intelligence and Electronic Warfare subsystem of the Army Battle Command System (ABCS) and will provide all source intelligence fusion to gain a timely and comprehensive understanding of enemy deployments, capabilities, and potential courses of action. With this knowledge, combat leaders will be able to view the battlefield and more effectively conduct the land battle. ASAS is a tactically-deployable ADP system providing a capability which will be used to receive and correlate data from strategic and tactical intelligence sensors/sources; produce ground battle situation displays, rapidly disseminate intelligence information; provide target nominations, help manage organic IEW assets, and assist in providing operations security support. ASAS is theater independent and designed to operate in peace-time, contingency, crisis, and low and high-intensity wartime environments. ASAS Block II strategy maximizes the use of Government Furnished Equipment; government and commercial Non-Developmental Item software; use of proven Office of Secretary of Defense and ACCS Command, Control, Communications and Intelligence software; incremental deliveries; and continuous user test and evaluation opportunities. This strategy provides early user capabilities and streamlines acquisition. ASAS-Extended is a directed acquisition based on a module approach using a mix of commercial and rugged NDI equipment that rounds out the active and reserve forces with a common intelligence fusion system earlier than originally planned.

TRANSPORTATION CHARACTERISTICS / LIMITATIONS:

HISTORICAL BACKGROUND:

- Oct 92 IOT&E for ASAS Block I.
- Jul 93 ASARC Milestone III for ASAS Block I.
- Aug 93 ASAS Block I FUE.
- Oct 93 DAB Milestone II for ASAS Block II.
- Oct 93 ASAS Block II EMD Contract Award.

REQUIREMENTS DOCUMENT: ROC was approved Jun 86; Phased ROC validated by JROC 21 Nov 91. ORD approved by HQDA, DCSOPS on 3 Aug 93. ORD (Change 2) approved 28 Jun 96. ORD Change 3 in staffing July 1997.

TYPE CLASSIFICATION: Limited Procurement, Block I, 4QFY93.

As a result of a schedule breach under ASAS Block II, a draft APB was submitted 4QFY96. A Deviation Report has already been submitted. Milestones will change when the APB has been approved. We anticipate approval during 1QFY97.

RELEASEABLE TO SECURITY ASSISTANCE CUSTOMERS: Yes

<u>EVENT SCHEDULE</u>	<u>FISCAL YEAR</u>	97	98	99	00	01	02
		1 2 3 4	1 2 3 4	1 2 3 4	1 2 3 4	1 2 3 4	1 2 3 4
Operational Evaluation Single Source		3					
Division XXI			1				
Operational Evaluation Analysis Control Element				3			
Block II Milestone III					3		

SYNOPSIS: ASAS PROVIDES ALL SOURCE CORRELATED INTELLIGENCE NOT ONLY TO COMMANDERS AT DIVISION, CORPS AND ECHELONS ABOVE CORPS BUT ALSO TO WARFIGHTER AT THE LOWEST LEVEL.

PM, INTELLIGENCE FUSION

CI/HUMINT MANAGEMENT SYSTEMS (CHIMS)

PRODUCT DIRECTOR: LTC Al Garcia, DSN 235-8159
 COMM 703/275-8159
 FAX: DSN 235-8251
 E-Mail: agarcia@asaspmo.belvoir.army.mil

ACQUISITION CATEGORY: III
ACQUISITION PHASE: MS III Production/Deployment

PE & LINE #: RDTE: 64321.DB41 OPA: BK5275



DESCRIPTION: CHIMS is the CI/HUMINT component of the Intelligence and Electronic Warfare (IEW) sub-element of the Army Battle Command System (ABCS). It is a counter intelligence and human intelligence automation system that meets Army tactical CI/HUMINT information collection, investigation, interrogation, operation, document exploitation, and force protection automation requirements. The architecture is built from three sub-elements. The first tier tactical component to a three tiered automation support architecture for tactical CI/HUMINT operations is the CI/HUMINT Automated Tool Set (CHATS). CHATS (pictured above) operates at the Counter Intelligence Team/Interrogation Prisoner of War (IPW) Team level. It provides CI and IPW teams the capability to collect, manage, receive, store and export text, electronic data, and digital imagery information. It is a man portable, commercial-off-the-shelf (COTS) and Government-Furnished-Equipment (GFE) system enclosed in cases that conform to airline carry-on baggage standards. The other two major components to the CHIMS architecture are the Counter Intelligence Operations/Interrogation Facility Workstation (OPS/IF WS) for DS/GS MI unit command and control which provides functional interfaces to the All Source Analysis System, and the CI Single-Source Processors (CI SSP) which will operate within the ASAS Analysis and Control Element (ACE). The standard workstation hardware configuration for the CI SSP and the OPS/IF WS will consist of baseline Common Hardware and Software (CHS) components.

TRANSPORTATION CHARACTERISTICS / LIMITATIONS: CHATS is a man portable, commercial-off-the-shelf (COTS) and Government-Furnished-Equipment (GFE) system enclosed in cases that conform to airline carry-on baggage standards.

HISTORICAL BACKGROUND:

Oct 96 Product office established.
 May 97 Milestone III (Phase I) Decision Review Approved.

REQUIREMENTS DOCUMENT: Change 3 to ASAS ORD in staffing July 1997.

TYPE CLASSIFICATION: Generic, May 1997; Standard 4QFY97.

RELEASEABLE TO SECURITY ASSISTANCE CUSTOMERS: Yes

EVENT SCHEDULE	FISCAL YEAR		97		98		99		00		01		02	
	QTR		1	2	3	4	1	2	3	4	1	2	3	4
Milestone III (Phase II) Acquisition Decision			4											
First Unit Equipped (FUE) CHATS			4											
Prototype OPS/IF Workstation					4									
First Unit Equipped (FUE) OPS/IF Workstation							1							
Complete Fielding to Active Force and Selected Reserve Force Units							1	-----	4					

SYNOPSIS: CHIMS PROVIDES AUTOMATION SUPPORT FOR ARMY TACTICAL COUNTER INTELLIGENCE AND HUMAN INTELLIGENCE (CI/HUMINT) INFORMATION COLLECTION, INVESTIGATION, INTERROGATION, OPERATION, DOCUMENT EXPLOITATION, AND FORCE PROTECTION AUTOMATION REQUIREMENTS FROM BATTALION TO EAC LEVELS.

PM, INTELLIGENCE FUSION

**INTEGRATED METEOROLOGICAL SYSTEM
(IMETS), AN/TMQ-40**

PROJECT DIRECTOR: Mr. Marvin Dubbin,
DSN 258-1984
COMM 505/678-1984
E-Mail: mdubbin@arl.mil

ACQUISITION CATEGORY: III
ACQUISITION PHASE: MS III Production/Deployment

PE & LINE #: RDTE: 64726.D85; OPA: BW0021

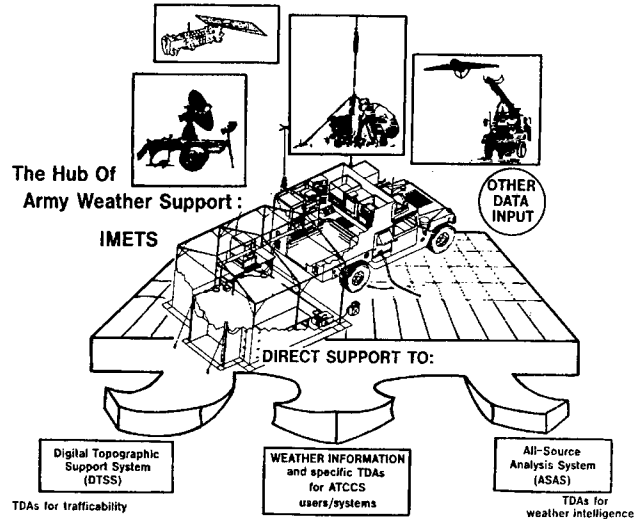

DESCRIPTION: IMETS is predominantly a Non-Developmental Item (NDI) that provides automation and communications support to USAF Weather Teams assigned to Army G2/G3 sections at echelons Brigade through EAC. IMETS receives, processes, and collates forecasts, observations, and climatological data to produce weather forecasts and timely and accurate products to meet Commanders' requirements. IMETS produces, displays and disseminates, over Army ATCCS, weather forecasts and tactical decision aids that compare the impact of current, projected, or hypothesized weather conditions on friendly and enemy capabilities. IMETS workstations are ATCCS Common Hardware and are interoperable with ASAS, DTSS and other ATCCS BFAs over tactical and area communications.

TRANSPORTATION CHARACTERISTICS / LIMITATIONS: Standard Integrated Command Post System (SICPS) mounted on a Heavy Highly Mobile Multipurpose Wheeled Vehicle (H-HMMWV). Length 206.5 inches, Width 89 inches, Height 120 inches, Weight 10,001 pounds, Square Footage 120 sq. ft. Limitations: None.

HISTORICAL BACKGROUND:

Feb 92	Milestone I/II approved.
Sep-Nov 93	EUTE.
Dec 93	Milestone III LRIP.
Jul-Sep 94	IOTE.
Oct 94	Block I Initial Operational Test and Evaluation.
Dec 94	Block I Milestone III Production/Deployment Decision.
Feb 97	Block II Follow-On Test and Evaluation.
Apr 97	Block II Milestone III Production/Fielding Decision.

REQUIREMENTS DOCUMENT: 0&0 approved Dec 86, ROC approved Mar 91; Change 1 approved Jul 92.

TYPE CLASSIFICATION: Block I Standard, Dec 94; Block II Standard, Feb 97.

RELEASEABLE TO SECURITY ASSISTANCE CUSTOMERS: Yes

EVENT SCHEDULE	FISCAL YEAR															
	97		98		99		00		01		02					
	QTR															
	1	2	3	4	1	2	3	4	1	2	3	4	1	2	3	4
IMETS Block II Integration	1	-----	4													
IMETS Block II Fielding			3	----	-----	4										
IMETS Block III Integration					1	-----	----	2								
IMETS Block III Fielding									3	----	-----	4				

SYNOPSIS: IMETS IS A TACTICAL AUTOMATED WEATHER DATA SYSTEM RECEIVING, PROCESSING, AND DISSEMINATING INFORMATION TO PROVIDE TIMELY WEATHER ENVIRONMENTAL EFFECTS, FORECASTS AND DECISION AIDS.

PM, INTELLIGENCE FUSION

JOINT COLLECTION MANAGEMENT TOOLS

PROJECT MANAGER: LTC Charles R. Ball,
 DSN 235-8134
 COMM: 703/275-8134
 FAX: DSN 235-8251
 E-Mail: crball@asaspmo.belvoir.army.mil

ACQUISITION CATEGORY: III
ACQUISITION PHASE: MS III Production/Deployment

PE & LINE #: O&MA: 411327.00 Technical
 Reconnaissance and Surveillance;
 RDTE: 371359.381 (In FY98, the PE for
 RDTE will change to 371359.892).

DESCRIPTION: JCMT is the DOD Intelligence Information System (DODIIS) migration system for all-source collection management. Its baseline is derived from the Army's Collection Management Support Tools (CMST). As the migration system, it will incorporate functionality from Defense Intelligence Agency's (DIA's) Collection Requirements Management Application (CRMA), the Air Force's Collection Requirements Management System (CRMS), the Operational Support Office's (OSO) UNIX-based National Exercise Support Terminal (UNEST), and USSOUTHCOM's Intelligence Support Processing Tool (ISPT). JCMT Version 0.0 has been defined as CMST Version 4.0. JCMT is the standard software product that will be used by national, theater, and tactical organizations of all services. JCMT will be delivered to tactical users as part of a service intelligence system, i.e., All Source Analysis System (ASAS) for the Army, Theater Battle Management Core System (TBMCS) for the Air Force, and Joint Maritime Command Information System (JMCIS) for the Navy and Marine Corps. JCMT provides tools for gathering, organizing, and tracking intelligence collection requirements for all intelligence disciplines. If existing products are not available, a collection manager can query JCMT's various databases and platform/sensor models for data about collection asset capabilities and availabilities. JCMT also supports the collection manager to develop collection plans and generate tasking and request messages.

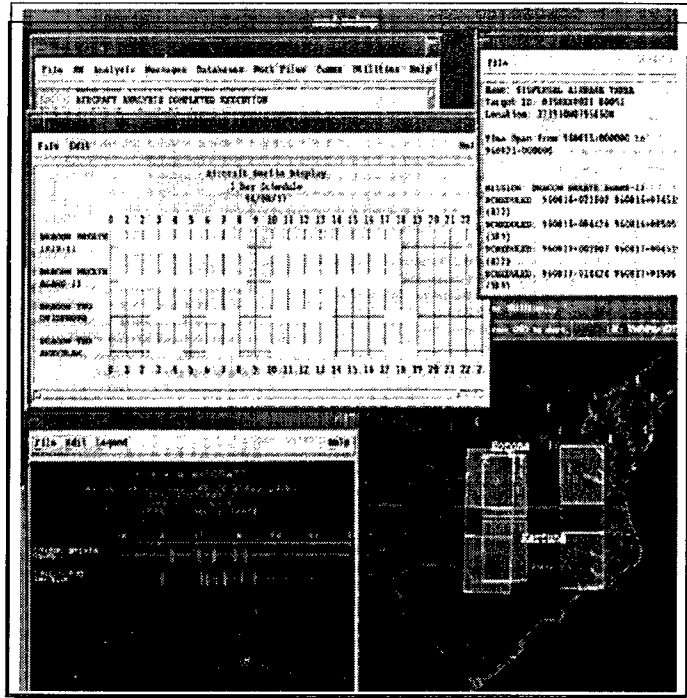

TRANSPORTATION CHARACTERISTICS / LIMITATIONS: Not applicable. JCMT is a software-only product.

HISTORICAL BACKGROUND:

- Jan 94 Military Intelligence Board (MID) approved the creation of the JCMT program.
- Oct 94 ASD (C3I) approved ISB recommendation that JCMT become the DOD migration system for all-source collection management.
- Feb 95 DIA-sponsored, EUCOM-hosted evaluation of legacy system functionality establishes initial requirements.
- May 96 Formal In-Process Review.

REQUIREMENTS DOCUMENT: The current list of 87 functional requirements to be added to the JCMT baseline was approved by the Collection Requirements Management Board (CRMB) on 19 July 1995 and baselined by its subordinate Functional Control Board Working Group (FCBWG) on 2 February 1996. Other requirements, in addition to the above, are outlined in a DIA message (081200Z May 96). These requirements were identified as "CRMA Deltas", or functions that CRMA currently performs that are not yet in JCMT. These other requirements are the focus of JCMT Capabilities Package 1 (CP1), scheduled for initial delivery in December 1997. An Operational Requirements Document has been prepared, but has not been approved by the Joint Requirements Oversight Council (JROC).

TYPE CLASSIFICATION: Not applicable.

RELEASEABLE TO SECURITY ASSISTANCE CUSTOMERS: No

EVENT SCHEDULE	FISCAL YEAR	97	98	99	00	01	02
		1 2 3 4	1 2 3 4	1 2 3 4	1 2 3 4	1 2 3 4	1 2 3 4
Capability Package 1 (CP1) Delivery (Initial Oper Cap)			1				
Capability Package 1.1 (CP1.1) Delivery			2				
Capability Package 1.2 (CP1.2) Delivery			4				
Capability Package 2 (CP2) Delivery (Full Oper Cap)				2			

SYNOPSIS: JCMT PROVIDES TOOLS FOR DOD COLLECTION MANAGERS AT ALL ECHELONS AND IN ALL SERVICES AND JOINT ORGANIZATIONS TO PROCESS COLLECTION REQUIREMENTS, FORMULATE AND MONITOR COLLECTION STRATEGIES, AND PREPARE COLLECTION TASKS AND REQUESTS.

PM, MILSATCOM

PM, Milsatcom

**AN/FRC-181(V)1 and AN/TRC-194(V)1, (V)2,
MILSTAR GROUND COMMAND POST
(GNDCP) TERMINALS**

PROJECT MANAGER: COL Michael Mazzucchi,
DSN 992-9767
COMM 908/532-9767
FAX: 908/532-1977
E-Mail: mazzuch@doim6.monmouth.army.mil

ACQUISITION CATEGORY: III
ACQUISITION PHASE: MS IV Operations/Support

PE & LINE #: SSN: BC4001

DESCRIPTION: The Milstar program is a multi-service satellite communications system (consisting of satellites and terminals) which will operate with Extremely High Frequency/Ultra High Frequency (EHF/UHF) uplinks and Super High Frequency (SHF)/UHF downlinks. The terminal segment will provide: worldwide; two-way; anti-jam; survivable; secure voice; teletype; and data communications enabling the National Command Authority (NCA) to command and control strategic and tactical forces through all levels of conflict and crisis. Milstar system must be operational and serviceable in a severe warfare environment, (e.g. nuclear, biological, chemical and electronic).

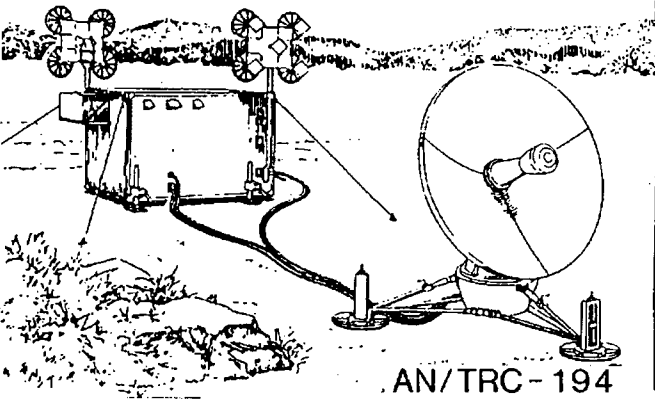
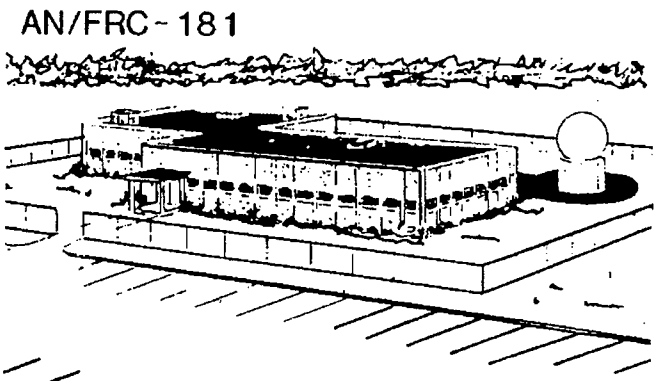

AN/FRC-181(V)1 is a GNDCP fixed terminal housed in an operational center and installed at CINC and Special User locations. At some sites, the terminal replaces the AN/GSC-40.
AN/TRC-194(V)1,2 is a GNDCP transportable terminal housed in a S-280 shelter, transported by two 5-ton vehicles and uses twin 30Kw generators with trailers. PM Milstar will integrate the GNDCPs into the Army force structure.

TRANSPORTATION CHARACTERISTICS / LIMITATIONS: None.

HISTORICAL BACKGROUND:

- | | | | |
|--------|---|--------|---|
| Feb 89 | Army assigns PM SCOTT as Level I SICA Manager for 16 JCS Validated Terminals. | Oct 92 | Milstar Program DAB. |
| Dec 89 | AF Low Rate Initial Production (LRIP) award Raytheon/Rockwell. | May 93 | Core Buyout Raytheon/Rockwell. |
| Jan 91 | Milstar Restructuring Plan approved. | Feb 95 | Fort McPherson initial turnover. |
| | | Oct 96 | Re-evaluation of requirements for a quantity of 7 terminals to be integrated into the Army force structure. |

REQUIREMENTS DOCUMENT: JORD, Oct 92.

TYPE CLASSIFICATION: USAF to type classify.

RELEASEABLE TO SECURITY ASSISTANCE CUSTOMERS: No

EVENT SCHEDULE	FISCAL YEAR		97		98		99		00		01		02	
	QTR		1	2	3	4	1	2	3	4	1	2	3	4
Final Turnover of Belvoir Terminals (2)			2											
Final Turnover Two Terminals to VIAHINGEN, GE			4											
Final Terminal to Ritchie			4											
Final Terminal to Shape Belgium							1							

SYNOPSIS: MILSTAR EHF-UHF GROUND COMMAND POST TERMINALS PROVIDE FIXED/SEMI-FIXED CAPABILITIES FOR NET CONTROL AND VOICE, TELETYPE AND DATA COMMUNICATIONS IN AN EXTREMELY HOSTILE ENVIRONMENT.

PM, Milsatcom

AN/PSC-5, "SPITFIRE" UHF DAMA TERMINAL

PRODUCT MANAGER: LTC Kevin M. Dietrick,
DSN 992-9645 x 4535 . COMM 732/532-9645 x 4535
FAX: DSN 992-3463
E-Mail: dietrick@doim6.monmouth.army.mil

PROJECT LEADER: Italo Villacis,
DSN 992-9645 x 4541 . COMM 732/532-9645 x 4541
FAX: DSN 992-3463
E-Mail: villacis@doim6.monmouth.army.mil

ACQUISITION CATEGORY: III
ACQUISITION PHASE: III

PE & LINE #: SSN: K77200

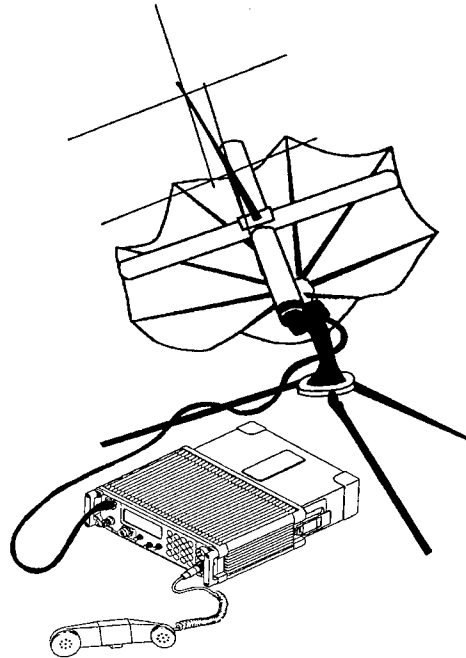

DESCRIPTION: The AN/PSC-5 "SPITFIRE" Manpack UHF SATCOM DAMA Terminal replaces the existing inventory of Single Channel UHF SATCOM radios. It contains embedded Communications Security (COMSEC) and Demand Assigned Multiple Access (DAMA). "SPITFIRE" provides elements of the Special Operations Forces (SOF), and other designated units of the Army, Air Force, Navy, and Marine Corps with small, lightweight terminals for half-duplex, secure, data and digital voice communications through ultra high frequency (UHF) satellites. In addition to the satellite relay communications mode, the "SPITFIRE" is capable of communicating line-of-sight (LOS). "SPITFIRE" employs burst transmission to provide shared use of 5 and 25 kilohertz (kHz) channels on existing and planned satellite transponders. In addition, it has the capability to access the satellite channels using DAMA techniques. "SPITFIRE" uses the Fleet Satellite (FLTSAT), commercial Leased Satellite (LEASAT) and UHF Follow-On satellite systems. In addition, the "SPITFIRE" system features extended frequency range from 30 MHz to 400 MHz. "SPITFIRE" major components consist of R/T with embedded COMSEC and DAMA, battery box, satellite antenna, LOS antenna and handset.

TRANSPORTATION CHARACTERISTICS / LIMITATIONS: Manpack.

HISTORICAL BACKGROUND:

- Aug 88 AMUT O&O Plan approved by TRADOC.
- Apr 91 DA directed procurement.
- Oct 92 Solicitation issued for AN/PSC-5 Competitive FFP contract.
- Feb 93 DA directed procurement amended. Phase II was incorporated into Phase I.
- Jan 94 Production contract awarded.

REQUIREMENTS DOCUMENT: DA Directed Procurement Apr 91.

TYPE CLASSIFICATION: Type Classified Standard approximately 3Q98.

RELEASEABLE TO SECURITY ASSISTANCE CUSTOMERS: Yes (within NSA COMSEC guidelines).

EVENT SCHEDULE	FISCAL YEAR																			
	97		98		99		00		01		02									
	1	2	3	4	1	2	3	4	1	2	3	4	1	2	3	4	1	2	3	4
FUE/IOC			4																	

SYNOPSIS: THE AN/PSC-5 SPITFIRE WILL PROVIDE ELEMENTS OF SOF & OTHER DESIGNATED UNITS OF THE ARMY, AF, NAVY, & MARINE CORPS WITH SMALL, LIGHTWEIGHT TERMINALS FOR SECURE DATA & DIGITAL VOICE COMMUNICATIONS THROUGH UHF SATELLITES.

PM, Milsatcom

FLYAWAY TRI-BAND SATELLITE TERMINAL (FTSAT) AN/USC-60

PROJECT MANAGER: COL Michael R. Mazzucchi,
DSN 992-9767, X 4001 COMM 732/532-9767, X 4001
FAX: 732/542-1065
E-Mail: mazzucch@doim6.monmouth.army.mil

PRODUCT MANAGER: LTC William D. Beatty,
DSN 992-2737 COMM 732/532-2737
FAX: 992-1293 COMM 732/532-1293
E-Mail: beattyw@doim6.monmouth.army.mil

ACQUISITION CATEGORY: IV
ACQUISITION PHASE: III

PE & LINE #: Customer

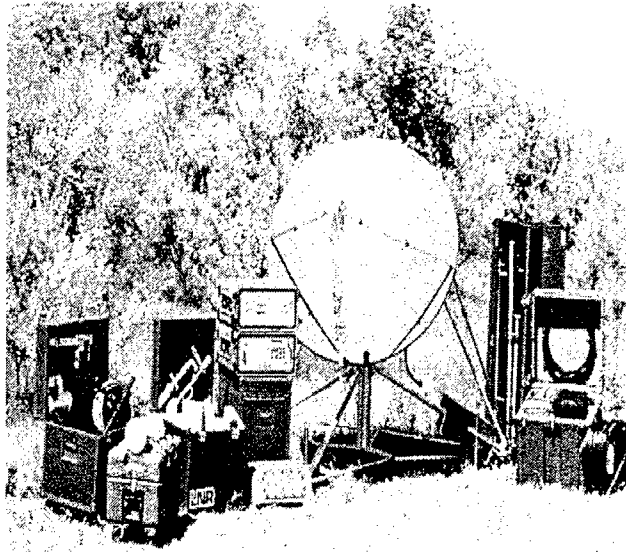

DESCRIPTION: The Flyaway Triband Satellite Terminal (FTSAT) is a Commercial Off the Shelf (COTS) Non-Development Item (NDI) transit case packaged satellite communications terminal. The FTSAT are primarily used by the Defense Intelligence Agency to support their requirements for a Joint Deployable Intelligence Support Systems (JDISS). The FTSAT will operate worldwide in the X, Ku, and C band with DSCS III, NATO III/IV, INTELSAT, EUTELSAT, PANAMSAT and DOMSAT. The terminal modem will interoperate with the GMF MCIS (AN/TSC-85/93/94/100) and the DSCS Gateway modems. The transit cases/packages will be man-portable with each case not to exceed 90 lbs in total weight. The MTBCMA will be greater than 250 hours with a Mean-Time Between Critical Failure of 5000 hours to ensure a 90% confidence level during a 60 day, 24 hour operating period per day.

TRANSPORTATION CHARACTERISTICS / LIMITATIONS: Man-portable.

HISTORICAL BACKGROUND:

FY94 PM SATCOM received request to procure FTSAT.
FY95 FFP Contract award from the Defense Intelligence Agency (DIA) to LNR Communications.

REQUIREMENTS DOCUMENT: N/A

TYPE CLASSIFICATION: N/A

RELEASEABLE TO SECURITY ASSISTANCE CUSTOMERS: Yes

<u>EVENT SCHEDULE</u>	<u>FISCAL YEAR</u>																							
	97		98		99		00		01		02													
	1	2	3	4	1	2	3	4	1	2	3	4	1	2	3	4	1	2	3	4	1	2	3	4
Delivery						2																		

SYNOPSIS: FTSAT WILL PROVIDE X, KU, AND C BAND SATELLITE COMMUNICATIONS IN A MAN-PORTABLE (NTE 90 LBS.) CONFIGURATION.

PM, Milsatcom

GLOBAL BROADCAST SERVICE (GBS)

PROJECT MANAGER: COL Michael Mazzucchi,
 DSN 992-9767
 COMM 732/532-9767
 FAX: 732/532-1977
 E-Mail: mazzuch@doim6.monmouth.army.mil

ACQUISITION CATEGORY: ID
 ACQUISITION PHASE: Production

PE & LINE #: BC4120

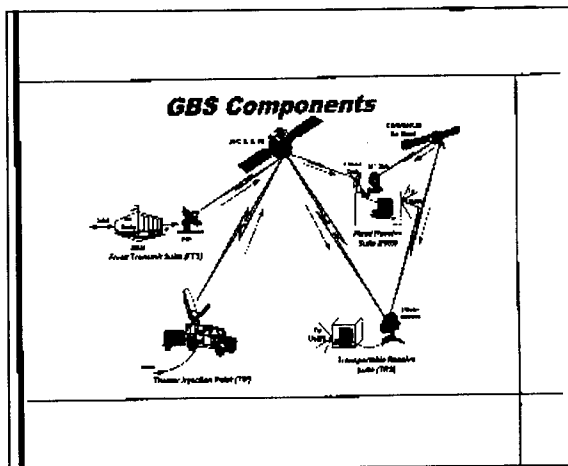

DESCRIPTION: The Global Broadcast Service was designated as a joint program on 27 Mar 96, by direction of the Under Secretary of Defense for Acquisition. The Air Force is the executive agent of this multi-service program. Global Broadcast Service will provide Joint Tactical Operations high speed, multimedia communications and information for deployed, on the move, or garrisoned forces. GBS will take advantage of new technology and information transfer systems to support modern warfare. The Global Broadcast Service will augment and interface with other communications systems and provide a continuous, high-speed, one-way flow of multimegabit video and data products. GBS will operate as a system of broadcast satellites under the Navy's UHF Follow-On (UFO) satellites program. The GBS JPO designated the Army to manage the terminal portion of the contract. This includes three fixed Primary Injection Point (PIP) terminals which will uplink information to the space segment. 1200 fixed, transportable, Ship Borne and Sub Surface receive suites and 3 Theater Injection Points (TIP) transmit vital CINC/CJTF/component directed in-theater information to the space segment.

TRANSPORTATION CHARACTERISTICS / LIMITATIONS: PIP is fixed; Transportable Receive Suite (TRS) is a two person lift - 42lb Transit Case; TIPs - Military Vehicle Mounted. C130 roll on/roll off.

HISTORICAL BACKGROUND:

- Aug 95 Mission Needs Statement.
- Jan 96 Concept of Operations Developed.
- Mar 96 Joint Space Management Board Acquisition Decision Memorandum.
- May 97 RFP to Industry.
- Jun 97 Proposals Received.

REQUIREMENTS DOCUMENT: Joint ORD validated 7 Apr 97.

TYPE CLASSIFICATION: N/A

RELEASEABLE TO SECURITY ASSISTANCE CUSTOMERS: Yes

EVENT SCHEDULE	FISCAL YEAR		97		98		99		00		01		02	
	QTR		1	2	3	4	1	2	3	4	1	2	3	4
Release GBS Solicitations			3											
GBS Contract Award					1									
Terminal Delivery					4	1	3	2		4			3	
Exercise Theater Injection Point Option					2			1		1				

SYNOPSIS: GBS PROVIDES HIGH SPEED, HIGH THROUGHPUT BROADCAST AND SIMPLEX DATA DISSEMINATION TO SMALL RECEIVE TERMINALS.

PM, Milsatcom

LIGHTWEIGHT HIGH GAIN X-BAND ANTENNA (LHGXA)

PROJECT MANAGER: COL Michael R. Mazzucchi,
DSN 992-9767 X 4001 COMM 732/532-9767 X 4001
FAX: 732/542-1065 DSN 992-1065
E-Mail: millera@doim6.monmouth.army.mil

PRODUCT MANAGER: LTC William D. Beatty,
DSN 992-2737 COMM 732/532-2737
FAX: 732/532-1293 DSN 992-1293
E-Mail: beatty@doim6.monmouth.army.mil

ACQUISITION CATEGORY: IV
ACQUISITION PHASE: III

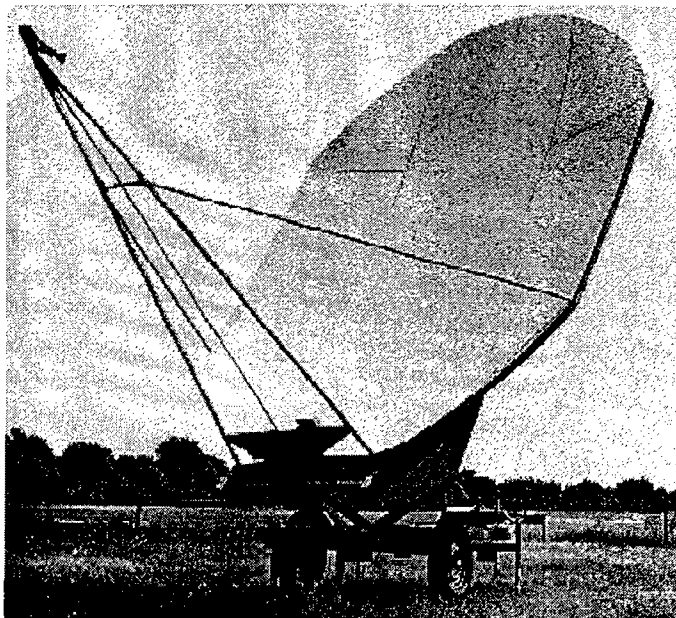

PE & LINE #: BB8417

DESCRIPTION: The LHGXA is an X Band only antenna that has a 16' reflector and is capable of the performance of a Quick Reaction Satellite Antenna (QRSAs) and designed to work with GMF terminals. Antennas are built onto a trailer configuration, not mobilizers, and will be towable by HMMWVs to 5T trucks (M939) and also can be air (C130 and rotary wing aircraft) as well as rail transportable. Basic contract is for 3 antennas with options for up to 58 more.

TRANSPORTATION CHARACTERISTICS / LIMITATIONS: C130 roll on/off.

HISTORICAL BACKGROUND:

Sep 95 Contract Award.

REQUIREMENTS DOCUMENT: O&O Plan, 1986.

TYPE CLASSIFICATION: N/A

RELEASEABLE TO SECURITY ASSISTANCE CUSTOMERS: Yes

<u>EVENT SCHEDULE</u>	<u>FISCAL YEAR</u>						
	97	98	99	00	01	02	
	1 2 3 4	1 2 3 4	1 2 3 4	1 2 3 4	1 2 3 4	1 2 3 4	
Contract Awards	4						
Deliveries		2					

SYNOPSIS: THE LHGXA 16FT SATCOM ANTENNA, C130 ROLL ON/OFF, RAIL, SLING-LOADABLE ANTENNAS, AUGMENT THE ARMY'S GMF TACSAT TERMINALS BY PROVIDING EQUAL OR BETTER PERFORMANCE THAN THE QRSA.

PM, Milsatcom

LIGHT MULTIBAND SATELLITE TERMINAL (LMST)

PROJECT MANAGER: COL Michael R. Mazzucchi,
DSN 992-9767 X 4001 COMM 732/532-9767 X 4001
FAX: 732/542-1065
E-Mail: mazzuch@doim6.monmouth.army.mil

PRODUCT MANAGER: LTC William D. Beatty,
DSN 992-2737 COMM 732/532-2737
FAX: 732/532-1293 DSN 992-1293
E-Mail: beatty@doim6.monmouth.army.mil

ACQUISITION CATEGORY: IV
ACQUISITION PHASE: III

PE & LINE #: Customer



Transit Case Configuration

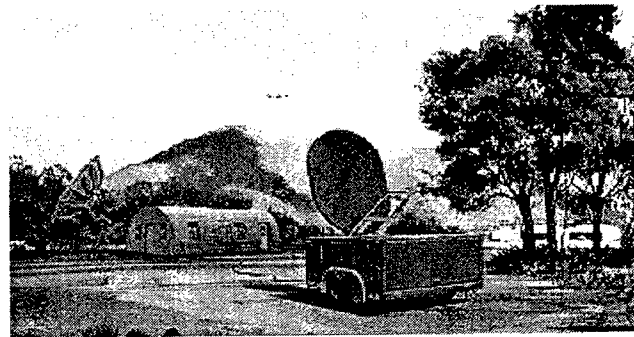

Trailer Configuration

DESCRIPTION: The LMST is a Tri-Band Super High Frequency Terminal. The terminal is contained on a single trailer or in transit case enclosures and shall operate over C, X, and Ku-Bands. The terminal shall operate worldwide with any spacecraft of the Defense Satellite Communications System (DSCS) II, DSCS III, North Atlantic Treaty Organizations (NATO) III, NATO IV, International Telecommunications Satellite Organization (INTELSAT), European Telecommunications Satellite Organization (EUTELSAT), Pan American Satellite Organization (PANAMSAT), and Domestic Satellite Organization (DOMSAT). The LMST terminal will interoperate with Ground Mobile Forces (GMF) AN/TSC-85/93/94/100 terminals and DSCS Gateways. Each terminal shall consist of the following major groups of equipment: Receiver Group, Transmitter group, Antenna group, Baseband group, Power group, Trailer group, and Auxiliary equipment group.

TRANSPORTATION CHARACTERISTICS / LIMITATIONS: LMST will provide Roll-on/Roll-off capability for transport on C-130, C-141, C-17, and C-5 type military aircraft. LMST Trailer configuration weight 6500 lbs and transit case configuration weight 3200 lbs.

HISTORICAL BACKGROUND:

- Jul 93 Contract Award - two prototypes.
- Jul 95 Contract Award - production.
- Jul 97 Operational Test.

REQUIREMENTS DOCUMENT: Theater Deployable Communications MNS - 27 Aug 93; Theater Deployable Communications ORD - 9 Feb 95; Acquisition Plan Document - 13 Jun 94.

TYPE CLASSIFICATION:

RELEASEABLE TO SECURITY ASSISTANCE CUSTOMERS: Yes

EVENT SCHEDULE	FISCAL YEAR	97	98	99	00	01	02
		QTR	1 2 3 4	1 2 3 4	1 2 3 4	1 2 3 4	1 2 3 4
Option Award		4	3				

SYNOPSIS: THE LMST PROGRAM WILL PROVIDE TRAILER AND TRANSIT CASE CONFIGURATIONS OF A TRI-BAND SUPER HIGH FREQUENCY (SHF) TERMINAL AND ASSOCIATED SUPPORT EQUIPMENT. THE TERMINAL SHALL BE CONFIGURED TO OPERATE IN THE SHF C, X, AND KU BANDS.

PM, Milsatcom

**LIGHTWEIGHT SATELLITE TERMINAL
UPGRADE (LST8000 (V)T)
(JCSE TRI-BAND TERMINAL UPGRADE)**

PROJECT MANAGER: COL Michael R. Mazzucchi,
DSN 992-9767 X 4001 COMM 732/532-9767 X 4001
FAX: 732/542-1065
E-Mail: mazzucch@doim6.monmouth.army.mil

PRODUCT MANAGER: LTC William D. Beatty,
DSN 992-2737 COMM 732/532-2737
FAX: 732/532-1293 DSN 992-1293
E-Mail: beatty@doim6.monmouth.army.mil

ACQUISITION CATEGORY: IV
ACQUISITION PHASE: III

PE & LINE #: Customer.

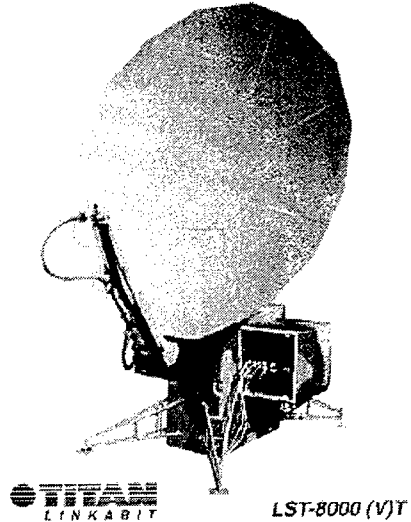

DESCRIPTION: The Titan Linkabit LST-8000(v)T is a portable/transit case (720 lbs and 27 cu. ft.) Tri-Band terminal that will give the user the capability of communicating over commercial satellites in the C and Ku bands as well as accessing the military DCSC satellites in X-band. Some major features of the LST-8000(V)T are:

- o Secure SHF communications at C, Ku and X bands.
- o Automatic satellite tracking.
- o Data rates up to 512 Kbs in C-band, 1.544 Mbs (T-1) in X-band and -9.4 Mbs (E-2) in Ku.
- o Packs into two man transit cases.
- o Highly transportable.
- o Remote operation.
- o Compatible with multiple PBX, vocoder, faxes and analog or digital devices.

TRANSPORTATION CHARACTERISTICS / LIMITATIONS: Portable, two man transit cases.

HISTORICAL BACKGROUND:

Jun 95 Contract award.
Apr 97 First system to be delivered.

REQUIREMENTS DOCUMENT: N/A

TYPE CLASSIFICATION: N/A

RELEASEABLE TO SECURITY ASSISTANCE CUSTOMERS: Yes

<u>EVENT SCHEDULE</u>	FISCAL YEAR	97	98	99	00	01	02
		1 2 3 4	1 2 3 4	1 2 3 4	1 2 3 4	1 2 3 4	1 2 3 4
Deliveries		3	1				

SYNOPSIS: THE LST-8000(V)T IS A PORTABLE TRI-BAND SYSTEM THAT WILL GIVE THE USERS THE CAPABILITY TO ACCESS WORLD WIDE COMMERCIAL SATELLITES AS A BACK UP MODE OF COMMUNICATING IN THE EVENT THAT THE MILITARY X-BAND SATELLITES ARE OVER SUBSCRIBED.

PM, Milsatcom

**SECURE MOBILE ANTI-JAM RELIABLE
TACTICAL TERMINAL (SMART-T)**

PROJECT OFFICER: COL Michael Mazzucchi,
DSN 992-9767 X4001
COMM 732/532-9767 X4001
E-Mail: mazzucch@doim6.monmouth.army.mil

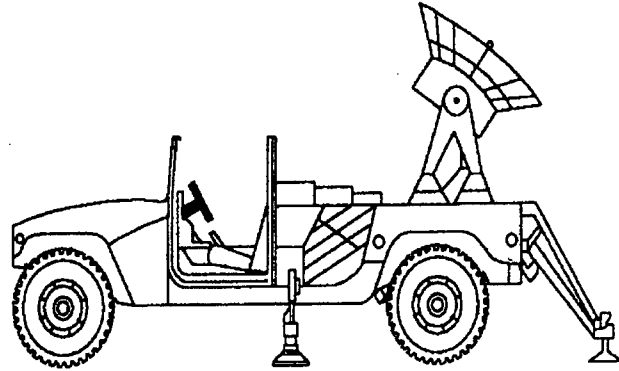

ACQUISITION CATEGORY: IC
ACQUISITION PHASE: MS II Eng/Manufacturing Dev

PE & LINE #: FY93 and Prior: 33142.455
FY94 and Beyond: 33142.D386/D2PT
SSN: BC4002
BS9702

DESCRIPTION: The SMART-T terminal will provide tactical users with secure, survivable, anti-jam, low probability of intercept and detection satellite communications in a High Mobility Multi-Purpose Wheeled Vehicle (HMMWV) configuration. This equipment will communicate/process data and voice communications at both low and medium EHF data rates. SMART-T will provide a range extension capability to MSE supporting Airland Operations. SMART-T provides a satellite interface to permit uninterrupted communications as our advancing forces move beyond the line-of-sight capability of MSE.

TRANSPORTATION CHARACTERISTICS / LIMITATIONS: None.

HISTORICAL BACKGROUND:

- Oct 90 Congressional direction to restructure Milstar.
- May 92 ASARC (Milestone II) approved.
- Nov 92 Dual development contracts awarded to Raytheon Co., Marlborough, MA & Rockwell International, Richardson, TX.
- Jan 96 Low Rate Initial Production (LRIP) Decision Review.
- Feb 96 Low Rate Initial Production (LRIP) contract with Full Rate Production (FRP) options awarded to Raytheon Company, Marlborough, MA.
- Dec 96 LRIP option awarded.

REQUIREMENTS DOCUMENT: Army Milstar Advanced Satellite Terminals (MAST) Operational Req'ments Document, Mar 92.

TYPE CLASSIFICATION: Type classified LRIP in FY96; Type Classification standard to be accomplished prior to MSIII Decision in FY99.

RELEASEABLE TO SECURITY ASSISTANCE CUSTOMERS: No

EVENT SCHEDULE	FISCAL YEAR															
	97		98		99		00		01		02					
	1	2	3	4	1	2	3	4	1	2	3	4	1	2	3	4
Conduct MST-6000 (Ground test prior to Sat Launch)					1-2											
Conduct First Article Test					1-2											
Conduct Initial Operational Test and Evaluation						3-4										
Milestone III Decision/Exercise 1st FSP Option								1								
Conduct MST-8000 (MDR on-orbit Sat Test)								3-4								
Conduct Follow-on Test & Evaluation								4	1							

SYNOPSIS: SMART-T PROVIDES USERS WITH SECURE, SURVIVABLE, ANTI-JAM, LOW PROBABILITY OF INTERCEPT AND DETECTION SATELLITE COMMUNICATIONS IN A HMMWV CONFIGURATION.

PM, Milsatcom

**SINGLE CHANNEL ANTI-JAM MANPORTABLE
TERMINAL (SCAMP) - BLOCK I**

PROJECT OFFICER: COL Michael Mazzucchi,
DSN 992-9767
COMM 732/532-9767
E-Mail: mazzucch@doim6.monmouth.army.mil

ACQUISITION CATEGORY: III
ACQUISITION PHASE: MS III Production/Deployment

PE & LINE #: FY93 and Prior: 33142.455
FY94 and Beyond: 33142.386
SSN: BC4003

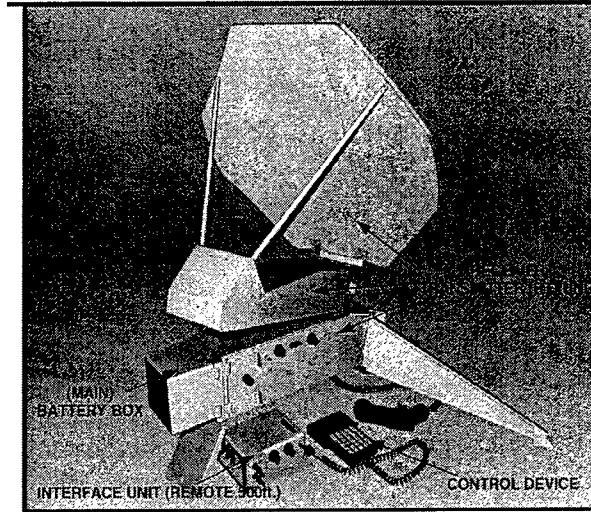

DESCRIPTION: **BLOCK I:** PM MILSTAR (Army) is responsible for development, acquisition, testing, product improvement and fielding of the Joint Service Extremely High Frequency (EHF) Milstar Program ground terminals segment. The Single Channel Anti-jam ManPortable (SCAMP) Terminal provides direct support to the tactical warfighter with secure anti-jam protection, lower probability of intercept and lower probability of detection. SCAMP is compatible with the Milstar waveform and interoperable with other terminals using the Milstar network. Block I is a 37 lb., single channel, Low Data Rate, user owned and operated terminal with a setup/teardown time of less than ten minutes. SCAMP - Block I has embedded COMSEC/TRANSEC and provides EMP protection with a Bio/Chemical protected case. Block I provides range extension interfacing with the Area Common User System (ACUS) and Combat Net Radio (CNR). The SCAMP terminal will be procured in a two block approach. Block I provides an interim manportable single channel, full duplex (half duplex for voice) satellite capability using today's technologies. Additional features on the production terminal include three black ports which require external encryption baseboard devices. The Block I program awarded a FFP Production contract in February 1996 for a quantity of 312. An option exists in FY98 for an additional Army quantity of 200. In Aug 97, the production contract was modified to procure 2 terminals for INSCOM.

TRANSPORTATION CHARACTERISTICS / LIMITATIONS: None.

HISTORICAL BACKGROUND:

- Nov 94 Advanced Planning Briefing to Industry held at Ft. Monmouth, NJ.
- Nov 94 AAE Acquisition Decision Memo (ADM) approved Full Scale Production (FSP).
- Apr 95 Redesignation of Block I to ACAT III by DAE.
- Feb 96 Firm Fixed Price (FFP) production contract awarded to Rockwell, Richardson, TX.

REQUIREMENTS DOCUMENT: Army Milstar Advanced Satellite Terminals (MAST) Operational Req'ments Document, Mar 92.

TYPE CLASSIFICATION: Apr 98 standard.

RELEASEABLE TO SECURITY ASSISTANCE CUSTOMERS: No

EVENT SCHEDULE	FISCAL YEAR															
	97		98		99		00		01		02					
	1	2	3	4	1	2	3	4	1	2	3	4	1	2	3	4
FRP Contract Option 1 Exercised	1															
FRP Contract Option 2					2											
FOT&E					2											
First Production Delivery					2											
IOC									1							

SYNOPSIS: SCAMP TERMINAL PROVIDES WORLDWIDE, ANTI-JAM LOW PROBABILITY OF INTERCEPT AND DETECTION, ASSURED VOICE AND DATA COMMUNICATIONS FOR SMALL UNITS THAT REQUIRE RANGE EXTENSION FOR C3.

PM, Milsatcom

**SINGLE CHANNEL ANTI-JAM MANPORTABLE
TERMINAL (SCAMP BLOCK II)**

PROJECT MANAGER: COL Michael Mazzucchi,
DSN 992-9767 X4001
COMM 732/532-9767 X4001
E-Mail: mazzucch@doim6.monmouth.army.mil

ACQUISITION CATEGORY: IC
ACQUISITION PHASE: MS I Demo/Validation

PE & LINE #: 0603856.D389

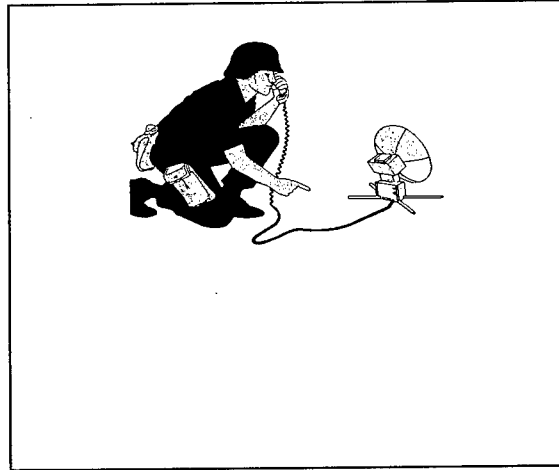

DESCRIPTION: The SCAMP BLOCK II program will provide a manportable 12-15 pound terminal to the tactical soldier. It will transmit and receive low rate data and voice in selectable point-to-point or broadcast modes. It will transmit in the EHF band and receive in the SHF band, and have a paging capability. Engineering Feasibility Efforts (EFE) approved at May 92 ASARC began in FY96 on packaging concepts; developing lightweight structures, composite drive motors, lightweight composite antenna petals; integrate mechanical prototype; develop paging system prototypes and perform digitalization studies. A prototype demonstration validation award is planned for 2QFY99. Production is planned for FY03.

TRANSPORTATION CHARACTERISTICS / LIMITATIONS: None.

HISTORICAL BACKGROUND:

May 92 ASARC Approved Engineering Feasibility Efforts (EFE).
Nov 94 Blk I MSIII Decision re-approved Block II EFE start in FY96.

REQUIREMENTS DOCUMENT: Army Milstar Advanced Satellite Terminals (MAST) Operational Req'ments Document, Mar 92.

TYPE CLASSIFICATION:

RELEASEABLE TO SECURITY ASSISTANCE CUSTOMERS: No

<u>EVENT SCHEDULE</u>	FISCAL YEAR	97	98	99	00	01	02
		1 2 3 4	1 2 3 4	1 2 3 4	1 2 3 4	1 2 3 4	1 2 3 4
Engineering Feasibility Efforts (EFE)		1-----	-----	-----4			
Prototype Demonstration/Validation				2-----4			
Milestone II/III Decision				4			
Award EMD Contract					2		

SYNOPSIS: SCAMP BLOCK II TERMINAL WILL PROVIDE 12-15 LB. MANPORTABLE, SECURE, ANTI-JAM COMMUNICATIONS, PAGING CAPABILITY TO THE TACTICAL SOLDIER.

PM, Milsatcom

**SPECIAL OPERATIONS FORCES TACTICAL
ASSURED CONNECTIVITY SYSTEM (SOFTACS)
TRI-BAND TERMINAL - AN/TSC-156(V)1**

PROJECT MANAGER: COL Michael R. Mazzucchi,
DSN 992-9767 X 4001 COMM 732/532-9767 X 4001
FAX: 732/542-1065 DSN 992-1065
E-Mail: mazzucch@doim6.monmouth.army.mil

PRODUCT MANAGER: LTC William D. Beatty,
DSN 992-2737 COMM 732/532-2737
FAX: 732/532-1293 DSN 992-1293
E-Mail: beatty@doim6.monmouth.army.mil

ACQUISITION CATEGORY: III
ACQUISITION PHASE: III

PE & LINE #: Customer

DESCRIPTION: SOFTACS provides assured connectivity between the Joint Special Operations Task Force (JSOTF) major subordinate commands, their major subordinate units, and other commands, as directed, in support of SOF missions. SOFTACS will be provided to units of the Army SOF (ARSOF) and Navy SOF (NAVSOF) component organizations. SOFTACS provides communications through the means of multiband, multichannel Super High Frequency (SHF) Satellite Communications (SATCOM) terminals; tropo-satellite support radio (TSSR) systems; digital circuit switches; remote trunking systems (RTS); tactical local area network (LAN) equipment; and message gateway servers.



TRANSPORTATION CHARACTERISTICS / LIMITATIONS: Heavy HMMWV Mounted with C-130 Roll on/Roll off capability.

HISTORICAL BACKGROUND:

Mar 94 Milestone 0 Decision.
May 95 Milestone I Decision.
Jan 96 Milestone II Decision.
Aug 96 Contract Award.

REQUIREMENTS DOCUMENT: SOFTACS ORD, 13 Oct 95.

TYPE CLASSIFICATION: Standard. 1Q99.

RELEASEABLE TO SECURITY ASSISTANCE CUSTOMERS: Yes (within NSA COMSEC guidelines).

<u>EVENT SCHEDULE</u>	<u>FISCAL YEAR</u>		97	98	99	00	01	02
	<u>QTR</u>		1 2 3 4	1 2 3 4	1 2 3 4	1 2 3 4	1 2 3 4	1 2 3 4
LRIP Phase					-1			
IOT&E				4	-1			
FUE					1			

SYNOPSIS: SOFTACS WILL PROVIDE THE SOF COMMUNITY WITH A SHF TRI-BAND CAPABILITY WHICH WILL OPERATE OVER COMMERCIAL AND MILITARY SHF SATELLITES.

PM, Milsatcom

**SUPER HIGH FREQUENCY (SHF) TRI-BAND
ADVANCED RANGE EXTENSION TERMINAL
(STAR-T) AN/TSC-156(V)3**

PROJECT MANAGER: COL Michael R. Mazzucchi,
DSN 992-2737 COMM 732/532-9767 X 4001
FAX: 732/542-1065 DSN 992-1065
E-Mail: mazzucch@doim6.monmouth.army.mil

PRODUCT MANAGER: LTC William D. Beatty,
DSN 992-2737 COMM 732/532-2737
FAX: 732/532-1293 DSN 992-1293
E-Mail: beatty@doim6.monmouth.army.mil

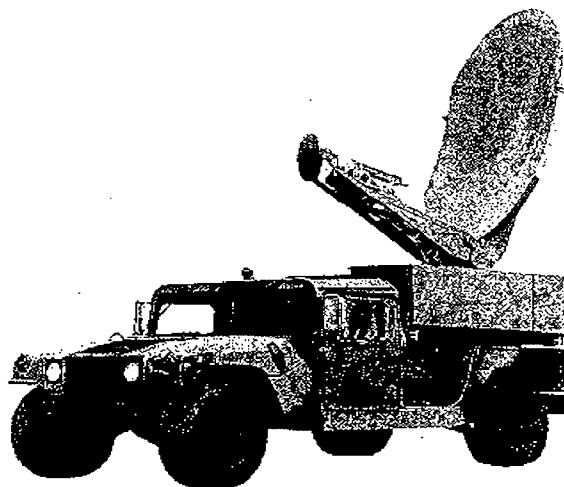

ACQUISITION CATEGORY: III
ACQUISITION PHASE: III

PE & LINE #: SSN: BA9350

DESCRIPTION: Super High Frequency (SHF) Tri-Band Advanced Range Extension Terminal (STAR-T) is a Heavy High Mobility Multi-purpose Wheeled Vehicle (HMMWV) mounted, multi-channel Tactical Satellite Terminal (TACSAT). It has a tri-band capacity in the SHF band and will operate over commercial and military SHF satellites. Selected terminals will also have an integrated switch that will interface with both commercial and joint military switching systems. The STAR-T has strong joint service applicability and potential for cooperative investment to replace current SHF multi-channel TACSAT terminals and some switching systems.

TRANSPORTATION CHARACTERISTICS / LIMITATIONS: Heavy HMMWV Mounted with C-130 Roll-on/Roll-off capability.

HISTORICAL BACKGROUND:

Aug 96 Contract Award (SOFTACS).
Dec 96 Milestone I-III A Decision.
Feb 97 Option contract award (STAR-T).

REQUIREMENTS DOCUMENT: MNS, May 94. ORD, Jan 96.

TYPE CLASSIFICATION: Standard, 1QFY00.

RELEASEABLE TO SECURITY ASSISTANCE CUSTOMERS: Yes (within NSA COMSEC guidelines).

<u>EVENT SCHEDULE</u>	<u>FISCAL YEAR</u>	97	98	99	00	01	02
		1 2 3 4	1 2 3 4	1 2 3 4	1 2 3 4	1 2 3 4	1 2 3 4
Contract Award		2					
LRIP Phase		2	-----	-----1			
IOT&E			4--	--1			
FUE					1		

SYNOPSIS: THE STAR-T PROGRAM WILL PROVIDE A TRI-BAND SUPER HIGH FREQUENCY TERMINAL AND ASSOCIATED SUPPORT EQUIPMENT.

PM, STCCS

PM, STCCS

COMBAT SERVICE SUPPORT CONTROL SYSTEM (CSSCS)

PRODUCT MANAGER: LTC Peter S. Janker,
DSN 656-5312
COMM 703/806-5312

ACQUISITION CATEGORY: ACAT IC
ACQUISITION PHASE: MS III Production/Deployment
PE & LINE #: 643805.D091

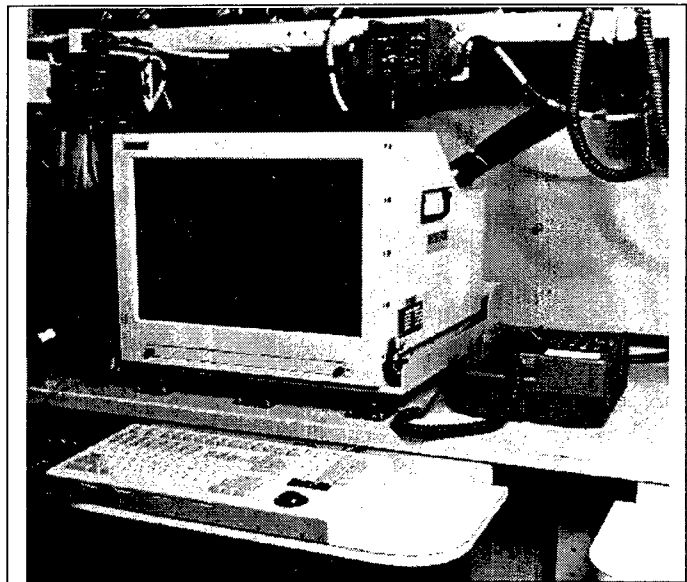

DESCRIPTION: The CSSCS is a computer software system designed to assist commanders and their staffs in the planning and execution of logistics operations. CSS commanders and staffs are currently participating in the force-level planning and decision making processes through a manual effort of gathering, correlating, and analyzing volumes of technical data from the existing Standard Army Management Information Systems (STAMIS). The CSSCS can extract summary information from the CSS STAMIS, accept input from other elements of the CSS community, and exchange information with other automated systems to evaluate CSS information with respect to the force-level commanders tactical courses of actions. The CSSCS is the combat service support component of the Army Battle Command System (ABCS). The CSSCS will be organic to CSS units and headquarters staffs within the maneuver brigades, separate brigades, armored cavalry regiments, Divisions, Corps, and Echelons Above Corps (EAC). The CSSCS will be comprised of computer units procured through the Project Manager Common Hardware/Software (PM CHS), Common Operating Environment (COE) Software and CSSCS-unique software. The CSSCS will be housed, as applicable, in the family of Standardized Integrated Command Post Systems (SICPS) provided by PM CHS.

TRANSPORTATION CHARACTERISTICS / LIMITATIONS: None.

HISTORICAL BACKGROUND:

- Apr 87 PM CSSCS established.
- Dec 90 Milestone I/II ASARC.
- Feb 91 Contract Award Version 3/4 SW; OSD C3I Committe Review.
- Oct 92 Completed Early User Test and Experimentation at Fort Hood, TX.
- Nov 93 Completed Limited User Test at Fort Hood, TX.
- Sep 94 Completed Initial Operational Test and Evaluation at Fort Hood, TX.
- Apr 95 LRIP Decision.
- Nov 96 Completed IOT&E-II at Fort Hood, TX.
- Mar 97 Milestone III ASARC.

REQUIREMENTS DOCUMENT: ORD approved April 1997.

TYPE CLASSIFICATION: April 1997.

RELEASEABLE TO SECURITY ASSISTANCE CUSTOMERS: Yes

EVENT SCHEDULE	FISCAL YEAR											
	97		98		99		00		01		02	
	1	2	3	4	1	2	3	4	1	2	3	4
Begin Version 5 Development					1							
ASARC III (FSP)	2											
FUE			1									
IOC					2							

SYNOPSIS: CSSCS WILL PROVIDE TIMELY CSS SITUATIONAL AWARENESS AND FORCE PROJECTION INFORMATION TO COMMANDERS AND THEIR STAFFS.

PM, STCCS

STANDARD THEATER ARMY COMMAND AND CONTROL SYSTEM (STACCS)

ACTG PROJECT MGR: Mr. Dan Gann,
DSN 987-2020
COMM 732/427-2020

ACQUISITION CATEGORY: IAC
ACQUISITION PHASE: MS III Production/Deployment

PE & Line #: 373150.C86 BA8250

DESCRIPTION: The Army Global Command and Control System (AGCCS) was initiated by the Directorate of Information Systems for C4 (DISC4) in mid 1993 to consolidate the development in certain Strategic & Theater programs in the

Army and to provide an implementation of the Army extensions to the Global Command and Control System (GCCS). AGCCS is a system development, integration, and maintenance effort initially consolidating existing projects: The Army WWMCCS Information System (AWIS), Standard Theatre Army Command and Control System (STACCS), and Combat Service Support Control System at Echelons Above Corps (CSSCS-EAC). In Oct 95, DISC4 directed that the Theater Automated Information C2 System (TACCIMS) be transitioned into AGCCS. AGCCS provides a source of technical support and services in fielding a seamless C2 structure for the EAC Army. This includes integration of the AGCCS core platform, reuse of functional capability as implemented in software modules currently existing in the AWIS, STACCS, CSSCS-EAC and TACCIMS maintenance of the existing systems, and development of new functional capabilities. A key part of the AGCCS development will be migration from current system support infrastructures to the DII single Common Operating Environment WWMCCS shutdown is key to AGCCS migration.

TRANSPORTATION CHARACTERISTICS / LIMITATIONS: Ruggedized hardware designed to be transportable in transit cases for semi-fixed operations. Commercial hardware (CHS-II) installed in fixed theater and headquarters locations.

HISTORICAL BACKGROUND:

- Nov 93 PM AWIS tasked to provide direct support to PM GCCS and to lead the Army GCCS effort.
- Jun 94 Initial AGCCS demonstration conducted.
- Jun 94 AGCCS contract RFP released.
- Jul 94 Merger of AWIS/STACCS.
- Oct 94 MAISRC IPR.
- Dec 94 Contract Award.
- Oct 95 TACCIMS added.
- Sep 96 WWMCCS Shutoff/AGCCS CPI IOC.

REQUIREMENTS DOCUMENT: The AGCCS System Specification, dated 21 April 94, consolidated requirements for the AWIS, CSSCS, and STACCS Projects.

TYPE CLASSIFICATION:

RELEASEABLE TO SECURITY ASSISTANCE CUSTOMERS: No

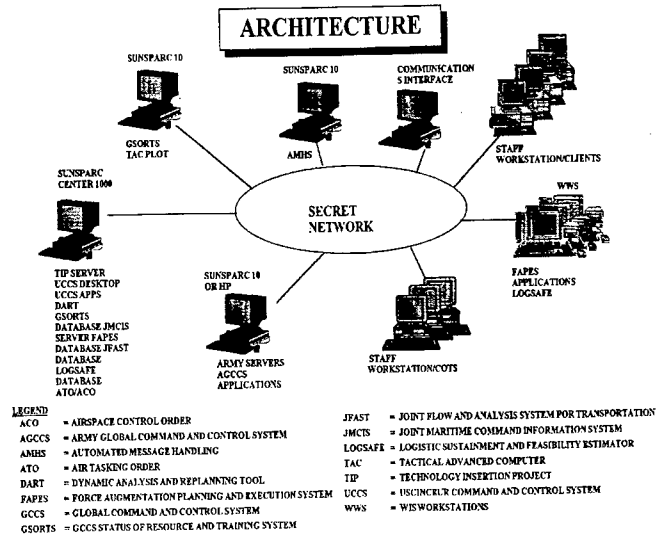

EVENT SCHEDULE	FISCAL YEAR	97	98	99	00	01	02
		1 2 3 4	1 2 3 4	1 2 3 4	1 2 3 4	1 2 3 4	1 2 3 4
Hardware Fielding							
Delivery 2		1-----4					
Delivery 3			1-----4				
Delivery 4				1-----4			

SYNOPSIS: AGCCS ALSO SUPPORTS THE INFORMATION COLLECTION, PROCESSING, DISTRIBUTION, DISPLAY SYSTEMS AND SOFTWARE APPLICATIONS FOR THE GCCS.

PM, TRCS

PM, TRCS

AN/TSQ-129, POSITION LOCATION REPORTING SYSTEM (PLRS)

PRODUCT MANAGER: Lt Col. J.J. Spegele (USMC)
DSN 987-2852
COMM 732/427-2852
FAX: 732/532-2321
E-Mail: spegele@doim6.monmouth.army.mil

ACQUISITION CATEGORY III
ACQUISITION PHASE: Fielded

PE & LINE #:

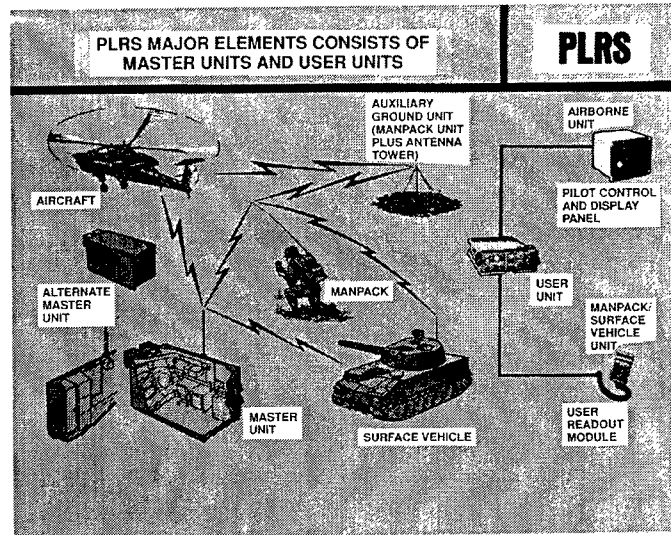

DESCRIPTION: The PLRS is a Command and Control aide that provides automatic, real-time position reporting in a division's area of responsibility. The system employs a Master Station and an Alternate Master Station for 100% backup to insure system survivability and continuity of operations during displacements. The Air Transportable Master Station provides computer controlled network management and continuously updates the position of deployed User Units in manpack, vehicle and airborne configurations. PLRS direct support maintenance will be aided through the use of special TMDE - the PLRS Test Set. PLRS equipped units can obtain their own position, range and bearing relative to other units or locations. PLRS equipped units also can establish aircraft corridor guidance and provide an alarm when entering a pre-designated restricted area such as a minefield, and provides a free format abbreviated data message from other users. The system is crypto-secure and is highly resistant to jamming. The network, under Master Station management automatically utilizes surface airborne User Units as integral relays to achieve over-the-horizon transmission and to overcome close-in terrain obstructions to line-of-site communications.

HISTORICAL BACKGROUND: PLRS is a USMC program managed by PM, TRCS.

Aug 76-Aug 80	Full Scale Development Contract.
Jul 82	ASARC/MSARC III approved PLRS for production.
Jul 83-Jul 86	Multi-year production contract award to HAC.
Sep 87	First Unit Equipped.
Oct 88	Fielding to MC completed.
May 90	PLRS Follow-On Buy for USMC and Navy awarded.
May 92	PLRS/EPLRS Control Station Downsize Contract Award to Unisys Corporation.
Mar 94	PLRS Navy Buy and PCE Phase 2A Awards.

REQUIREMENTS DOCUMENT: Joint Service Operational Requirement (JSOR) approved 1976; JSOR update May 83. USMC Required Operational Capability (ROC) for PLRS improvement program, 11 Jan 91.

TYPE CLASSIFICATION: Standard A as of 1 Sep 82 ASARC-III. To date 98% of NSNs have been received. All development line items numbers (ZLIN) have been converted to standard line item numbers.

RELEASEABLE TO SECURITY ASSISTANCE CUSTOMERS: Yes

SYNOPSIS: PLRS PROVIDES TIMELY AND ACCURATE THREE DIMENSIONAL POSITIONING, LOCATION, AND REPORTING INFORMATION IN SUPPORT OF TACTICAL COMMANDERS.

PM, TRCS

ENHANCED POSITION LOCATION REPORTING SYSTEM (EPLRS)

PRODUCT MANAGER: LTC John Weinzettle,
 DSN 992-3660
 COMM 732/532-3660
 FAX: 732/532-2321
 E-Mail: weinzett@doim6.monmouth.army.mil

ACQUISITION CATEGORY: II
ACQUISITION PHASE: III
PE & LINE #: 63713.D370 BU1400

DESCRIPTION: EPLRS provides secure, jam-resistant, near real-time data communications support for the five Battlefield Functional Areas of the Army Tactical Command and Control System (ATCCS) and provides a data backbone for Situational Awareness and Tactical Internet operations for Force XXI activities and Army Warfare Experiments. EPLRS is a Time Division Multiple Access System using a frequency hopping, spread spectrum waveform in the UHF band. It incorporates internal COMSEC devices of the Thornton family and has an Over The Air Rekeying (OTAR) capability. EPLRS will use both the Army Data Distribution System version of the X.25 CCITT and MIL-STD-1553B protocols to interface with ATCCS and selected weapons and command and control systems. Additionally, EPLRS provides battlefield situational awareness to both the user and to their higher headquarters. This information greatly enhances the command and control of tactical units by providing commanders with the location of friendly units, a dynamic representation of the Forward Line of Troops and abbreviated SITREPs for conditions and identification of adjacent equipped units. The major components of EPLRS are the downsized Net Control Station-EPLRS (NCS-(D)), EPLRS Radio Set with its user input/output devices. A typical army division will have four NCS-E(D)s and 600-700 EPLRS Radio Sets. EPLRS deploys as a total system with NCS-Es controlling communities of EPLRS radio sets. EPLRS Radio Sets originate, relay and receive messages.

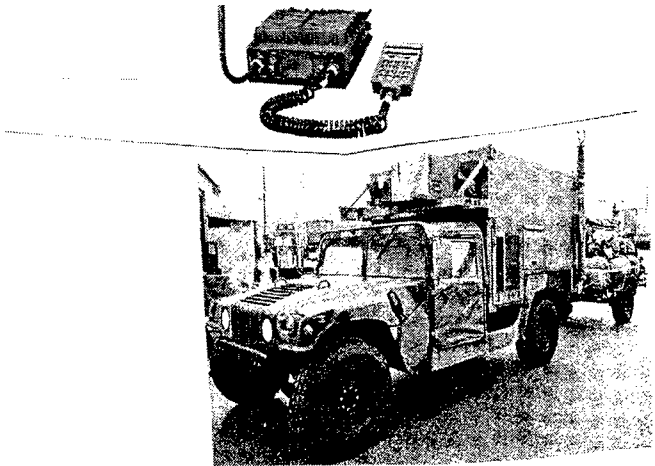

TRANSPORTATION CHARACTERISTICS/LIMITATIONS: NCS-E (D) 8.5'x7'x6', 4400lbs. EPLRS Radio Set 14.7"x10.5"x 5.1", 28lbs.

HISTORICAL BACKGROUND: EPLRS concept is a Preplanned Product Improvement (P3I) to the USA/USMC PLRS program. Technology insertions will be incorporated as part of the P3I process.

- Sep 78 System definition contract award to HAC.
- Jan 90 P3I Phase C (LRIP) contract awarded to HAC.
- May 94 VHSIC Contract awarded to HAC.
- Jan 95 Initial fielding to 1st Cav.
- Jun 95 Initial fielding to 24 ID (31D).
- Feb 96 Complete fielding (Phase II) to 1st CAV.
- Aug 96 Phase I IOT&E complete.
- Dec 96 Phase II IOT&E complete.
- Feb 97 MIII Decision Review.
- Sep 97 Full Rate Production contract award to HAC.

REQUIREMENT DOCUMENTS: PLRS/JTIDS Hybrid (EPLRS and JTIDS) Letter of Agreement approved Jun 82; ORD approved Nov 95; O&O revised Oct 86.

TYPE CLASSIFICATION: Currently Limited Procurement, standard anticipated for fielding.

RELEASEABLE TO SECURITY ASSISTANCE CUSTOMERS: No

EVENT SCHEDULE	FISCAL YEAR		97	98	99	00	01	02
	QTR		1 2 3 4	1 2 3 4	1 2 3 4	1 2 3 4	1 2 3 4	1 2 3 4
OT Phase II			1					
MIII Decision Review			2					
Full Rate Production Award			4					

SYNOPSIS: EPLRS PROVIDES POSITION LOCATION NAVIGATION AND SECURE JAM-RESISTANT COMMUNICATIONS SUPPORT FOR THE FIVE BFAs OF ATCCS.

PM, TRCS

JOINT TACTICAL INFORMATION DISTRIBUTION SYSTEM (JTIDS)

PROJECT MANAGER: LTC Patrick Short,
DSN 987-4362
COMM 732/427-4362
E-Mail: short@doim6.monmouth.army.mil

ACQUISITION CATEGORY: ID
ACQUISITION PHASE: FRP MS III Production

PE & LINE #: 63713.D385 BU150

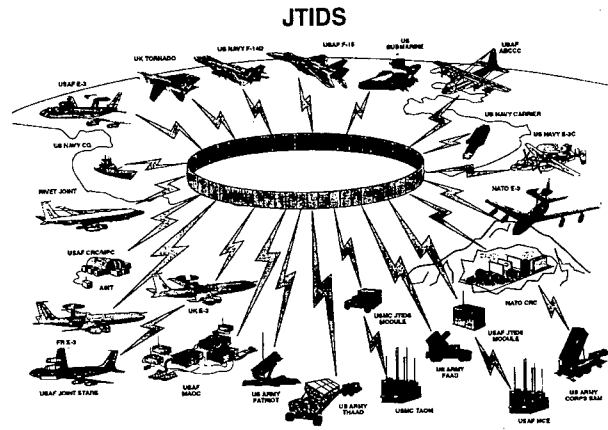

DESCRIPTION: The Joint Tactical Information Distribution System (JTIDS)/Multifunctional Information Distribution System (MIDS), LINK-16 program is a joint/international program representing all services and allied force requirements with the purpose of complying with the ASD/C3I policy establishing Link-16 as the DOD primary tactical datalink for C2I and to acquire a digital information system for tactical interoperability and situation awareness. Currently, the Army utilizes the JTIDS and MIDS terminals to provide Link-16 capability in Air Defense platforms to control air and missile defense weapon engagement operations. The Air Defense platforms include: Forward Area Air Defense Command Control Intelligence (FAADC2I); PATRIOT; Theater High Altitude Air Defense (THAAD); Medium Extended Air Defense (MEADS); Joint Tactical Ground Station (JTAGS) and Army Air Defense Brigade/Theater Missile Defense, Tactical Operational Center (ADA Bde/TMD TOC). The total contractual requirement is 80 Class 2M and 88 MIDS terminals with 2 FMS Class 2M terminals. A contract for 37 Class 2M terminals was awarded on 26 March 1996, a FRP contract for 45 CL2M Terminals (FY97 34, FY98 11) was awarded 3 Jun 97, and the remaining terminals will be procured through FY02. The Class 2M terminal interfaces with ACCS CHS and the JTIDS Terminal Controller (JTC) using the ADDS Interface (ADDISI) version of X.25 CCITT protocol. The Army will procure and field a minimum number of JTIDS Class 2M terminals to satisfy the Army's immediate Link-16 requirement. When the MIDS (LVT(2)) has demonstrated it can meet the Army's operational requirements, the Army will transition from the JTIDS Class 2M to the more affordable MIDS (LVT(2)) in FY99.

TRANSPORTATION CHARACTERISTICS / LIMITATIONS: Weight: 83 lbs., Size: 21x13x25 (1.25 cubic foot); Frequency Band (MHZ): 960-1215.

HISTORICAL BACKGROUND: PM TRCS with USAF Joint Program Office (JPO) is responsible for the management of the Class 2M terminals. PM TRCS with Navy Joint/International Program Office (IPO) is responsible for the management of the MIDS LVT (2) terminals.

- Jun 94 Award of 16 Class 2M terminals for THAAD and CORPS SAM (BMDO).
- Sep 94 Award of 4 Class 2M terminals for Patriot.
- Dec 94 Limited User Test successfully completed.
- Mar 95 Defense Acquisition Board (DAB) approved for 37 LRIP Class 2M terminals.
- Aug 95 Award Army MIDS Variant (LVT(2)) EMD Phase.
- Mar 96 LRIP Contract award for 37 JTIDS terminals.
- Apr-Sep 96 JTIDS Development Test/RAM completed.
- Oct-Nov 96 JTIDS Operational Test/Multiservice Test completed.

REQUIREMENTS DOCUMENT: JTIDS ORD approved Sep 93/JTIDS ORD updated 15 Jul 96.

TYPE CLASSIFICATION: JTIDS Class 2M FRP DAB Decision scheduled for 18 Mar 97.

RELEASEABLE TO SECURITY ASSISTANCE CUSTOMERS: Yes

EVENT SCHEDULE	FISCAL YEAR	QTR				
		97	98	99	00	01
		1 2 3 4	1 2 3 4	1 2 3 4	1 2 3 4	1 2 3 4
Development/Multiservice Test/Operational Test (Apr-Nov 96)		-1				
Milestone IIIB (Class 2M) (Mar 97)		2				
Production Award (Mar 97)		1-3				
Low Rate Initial Production Delivery (Jan 98)			1			
Production Delivery (Feb 99)				2		

SYNOPSIS: JTIDS PROVIDES (AS A MAJOR COMPONENT OF THE ARMY DATA DISTRIBUTION SYSTEM) HIGH CAPACITY SECURE, JAM-RESISTANT DIGITAL DATA COMMUNICATION. MULTISERVICE, NATO INTEROPERABILITY AND SITUATIONAL AWARENESS.

PM, TRCS

SINGLE CHANNEL GROUND and AIRBORNE RADIO SYSTEM (SINGGARS)

PROJECT OFFICERS:

GROUND: Dominic Satili, DSN 992-2521
 COMM 732/532-2521
 E-Mail: satilid@doim6.monmouth.army.mil

AIRBORNE: Thomas Keapproth, DSN 987-3025
 COMM 732/427-3025
 E-Mail: keapprotht@doim6.monmouth.army.mil

ACQUISITION CATEGORY: IC
ACQUISITION PHASE: MS III Production/Deployment

PE & LINE #: IT463746.D555; IT464751.D282;
 ITY64805.D282

SSN: B00500; J30500; BA9102
 BS9722

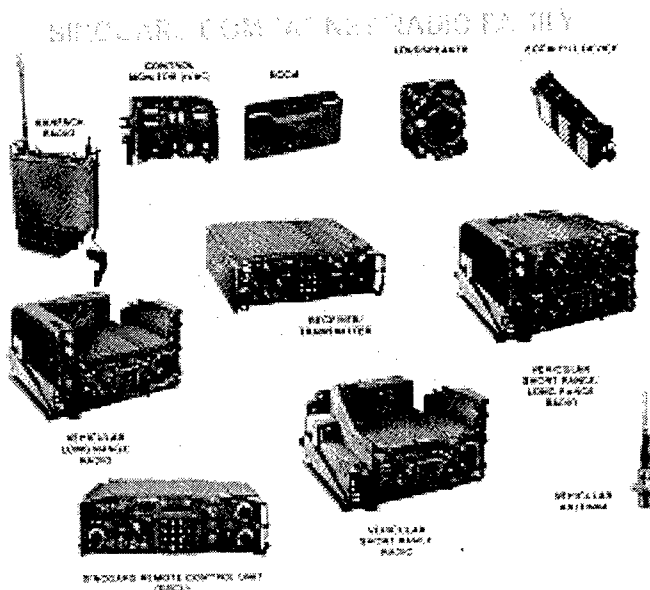

DESCRIPTION: SINGGARS is a new family of VHF-FM combat net radios which provides the primary means of command and control for Infantry, Armor and Artillery Units. SINGGARS is designed on a modular basis to achieve maximum commonality among the various ground and airborne system configurations. A common Receiver Transmitter (RT) is used in the manpack and all vehicular configurations. SINGGARS family of radios has the capability to transmit and receive voice, tactical data and record traffic messages and is consistent with NATO interoperability requirements. The system operates on any of the 2320 channels between 30-88 megahertz and is designed to survive in a nuclear environment. COMSEC for the basic radio is provided by use of the VINSON device. An Integrated COMSEC (ICOM) version of the SINGGARS is currently in production. SINGGARS is operable in a hostile environment through use of Electronic Counter Countermeasure (ECCM). SINGGARS replaces the current standard manpack and vehicular radios, AN/PRC-77 and AN/VRC-12 family, respectively. An airborne version of the SINGGARS radio is in production and will replace the currently standard aircraft radios, AN/ARC-114 and AN/ARC-131.

TRANSPORTATION CHARACTERISTICS / LIMITATIONS: None.

HISTORICAL BACKGROUND:

- Dec 83 Initial Ground contract award to ITT.
- May 85 Initial Airborne contract award to ITT.
- Jul 88 Initial Ground contract awarded to General Dynamics.
- Apr 89 Milestone IIIB (ITT); Non-ICOM full-rate production.
- Dec 90 Milestone IIIB ITT full rate (ICOM)/General Dynamics low rate; IOC (1st Division Equipped).
- Mar 91 Ground General Dynamics Option 1 Award.
- Mar 92 Ground and Airborne ITT award (PY 6/7). (GD alignment).
- Aug 93 Ground General Dynamics Full Rate Production approved.
- Apr 94 ITT/GD Competitive awards - Ground Radio.
- May 94 Follow-on Sole Source to ITT - Airborne Radio with options in FY95, FY96 and FY97.
- Mar 95 ITT/GD Competitive awards - Ground Radio.
- Apr 96 ITT/GD Competitive awards - Ground Radio.
- Apr 97 ITT Competitive Down-Select-Ground Radio.

REQUIREMENTS DOCUMENT: ROC approved 19 Dec 74, updated 10 Jan 75; Joint Operational Requirement approved 26 Mar 76, and updated 2 Mar 93.

TYPE CLASSIFICATION: Non-ICOM, Standard A, 21 Sep 83; Airborne full rate production, 14 Dec 90; ITT ICOM Ground full rate production, 14 Dec 90, GD ICOM Ground Full Rate production, 18 Aug 93.

RELEASEABLE TO SECURITY ASSISTANCE CUSTOMERS: Yes

EVENT SCHEDULE	FISCAL YEAR											
	97		98		99	00	01					
	1	2	3	4	1	2	3	4	1	2	3	4
PY 12 Production Award (Ground SINGGARS) ASIP					2							

SYNOPSIS: SINGGARS PROVIDES VHF-FM (30-88 MEGAHERTZ) COMBAT NET RADIO COMMUNICATION WITH ECCM CAPABILITY (FREQUENCY HOPPING) AND DIGITAL DATA CAPABILITY (DATA RATE ADAPTER).

PM, TRCS

**TD-1456/VRC, FREQUENCY HOPPING
MULTIPLEXER (FHMUX)**

PROJECT OFFICER: Mr. Doug Antisell,
DSN 987-3027
COMM 732/427-3027

ACQUISITION CATEGORY: III
ACQUISITION PHASE: MS III Production

PE & LINE #: 644805 DEV LIN: Z28333

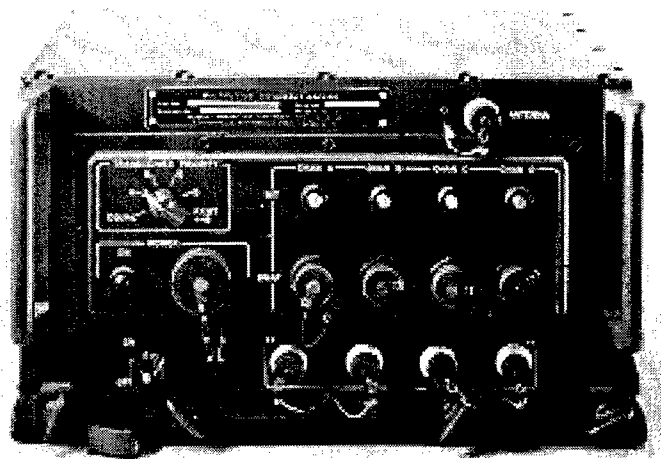

DESCRIPTION: Tactical C3 vehicles frequently support installations of four SINCGARS radios and four whip antennas. The multiple antennas readily identify the vehicle as a C3 platform and invite enemy firepower. FHMUX will mask tactical C3 functions by reducing the vehicle's antenna visual signature. The FHMUX will allow up to four SINCGARS radios, in frequency hopping or fixed frequency modes of operation, to use a single high power broadband antenna. The FHMUX will replace the manually tuned, fixed-frequency TD-1289 multiplexer currently in the Army inventory. Additional benefits of the FHMUX are a reduction of antenna setup and teardown times, and a well defined radio frequency isolation between radios to mitigate cosite interference.

TRANSPORTATION CHARACTERISTICS / LIMITATIONS: Weight: Less than 75lbs., Size: 1 cu ft; Enhanced Co Site 40 dB @ 5% Freq Sep.

HISTORICAL BACKGROUND:

- Jul 87 O&O Plan approved.
- Sep 89 FSD contract awarded to Xetron.
- Aug 94 TT Completed.
- Nov 94 OT Completed.
- Feb 95 PPQT Contract awarded to XETRON.
- Apr 96 Production Contract awarded to XETRON.
- Dec 96 Option 1 Contract awarded to XETRON.
- Jul 97 Start of production acceptance testing.

REQUIREMENTS DOCUMENT: ROC approved, May 91.

TYPE CLASSIFICATION:

RELEASEABLE TO SECURITY ASSISTANCE CUSTOMERS: Yes

<u>EVENT SCHEDULE</u>	<u>FISCAL YEAR</u>				
	97	98	99	00	01
	1 2 3 4	1 2 3 4	1 2 3 4	1 2 3 4	1 2 3 4
Option 1 Contract Award	1				
Initial Production Delivery		1			
Option 1 Delivery		3			

SYNOPSIS: FHMUX WILL EXTEND A MULTIPLEXING CAPABILITY TO SINCGARS FREQUENCY HOPPING RADIOS AND WILL REDUCE COSITE INTERFERENCE.

PM, WIN-T

PM, WIN-T

AN/TRC-138A, B & C, RADIO REPEATER SETS

PROJECT OFFICER: Ms. Noreen Polo,
DSN 992-3525
COMM 732/532-3525

ACQUISITION CATEGORY: III
ACQUISITION PHASE: MS III Production/Deployment

PE & LINE #:

DESCRIPTION: The AN/TRC-138A (fullsize), AN/TRC-138B (downsize), and AN/TRC-138C (HMDA) Radio Repeater Sets provide facilities terminating multi-channel radio and cable groups. The Radio Repeater Sets utilize three AN/GRC-222

radios, one AN/VRC-46 or AN/VRC-90 radio, and portions of the Digital Group Multiplexer (DGM) family of equipment. The DGM equipment which is being utilized is as follows: TD-1237(P)/H, MD-1026(P), Order Wire Control Unit C-10717/TRC, and MD-1024. The AN/GRC-222 also provides Short Range Wide Band Radio (SRWBR) for transmitting multiplexed groups from the radio park "Top-of-the-Hill" to the switching node "Bottom-of-the-Hill". It has the capability to terminate up to three systems and may be used for radio repeater, terminal, or SRWBR applications. The radio operates in the frequency range of 4.4 to 5.0 gigahertz. In the SRWBR mode it has a data rate of up to 18.72 megabits per second with a range of five miles. In the radio repeater mode it has a data rate of 4.608 megabits with a range of 25 miles. The AN/TRC-138A is mounted in an S-280C shelter and the AN/TRC-138B version is mounted in an S-749 shelter. The AN/TRC-138C is mounted in an S-805/G shelter and is transported on a M1113 Expanded Capacity HMMWV. A second M1113 transports the antenna pallet with the AB-1373, 30 meter antenna masts. The AN/TRC-138C also includes a cargo trailer for transport of ancillary items. 10 Kw power is supplied by an on-board APU or a towed PU-798.



TRANSPORTATION CHARACTERISTICS / LIMITATIONS: AN/TRC-138A and AN/TRC-138B roll-on/roll-off for C-5 only. AN/TRC-138C roll-on/roll-off capable for C-130, C-141, C5 aircraft.

HISTORICAL BACKGROUND:

1980 DT/OT-II.
1982 Army initiated production effort with TOAD.
Feb 84 TOAD First Article Tests (mechanical and electrical) completed.
Oct 87 FOT&E completed. New production contract awarded to Laguna Industries.
Jul 89 Production contract (downsize) awarded to Laguna Industries.
Mar 93 HMDA Variant Version Re-Packing Effort Initiated/Contract Modified.
Aug 94 HMDA Follow-on production contract awarded.

REQUIREMENTS DOCUMENT: HQDA Letter Requirement, 19 Mar 76.

TYPE CLASSIFICATION: Standard A approved Jul 81. Updated by Material Status Record change May 90.

RELEASEABLE TO SECURITY ASSISTANCE CUSTOMERS: Yes

SYNOPSIS: AN/TRC-138A & AN/TRC-138B RADIO REPEATER SETS PROVIDE FACILITIES FOR TERMINATING MULTICHANNEL RADIO/CABLE GROUPS FROM THE RADIO PARK "TOP-OF-THE-HILL" TO THE SWITCHING NODE "BOTTOM-OF-THE-HILL" FOR ECHELONS ABOVE CORPS SIGNAL UNITS.

PM, WIN-T

AN/TRC-173()

PROJECT OFFICER: Ms. Noreen Polo,
DSN 992-3525
COMM 732/532-3525

ACQUISITION CATEGORY: III
ACQUISITION PHASE: MS III Production/Deployment

PE & LINE #:

DESCRIPTION: The 173 (Fullsize), 173A (Downsize) and 173B (HMDA) is used as an extension terminal at major nodes to provide up to 36 channels of digital trunk communications. AN/TRC-173() contains two complete communication systems housed in a shelter facility. The AN/TRC-173() is composed of two AN/GRC-103(V)4 radio sets, one AN/VRC-46 or AN/VRC-90, and portions of the Digital Group Multiplexer (DGM) family of equipment. The DGM equipment, which is being utilized, is as follows: MD-1026(P)/G, MD-1023(P)/G, MD-1065/G, TD-1234(P)/TTC, MD-1025/G, TD-1236/G and Orderwire Control Unit C-10716/TRC. COMSEC equipment, which includes the KY-57 VINSON, KG-94 Trunk Encryption Device and KY-68 DSVT is also included as part of the assemblage. Each of the two communication systems in the AN/TRC-173() is capable of full duplex operation (simultaneous send and receive). Under normal operating conditions, one system in the AN/TRC-173() assemblage remains in standby condition in the event of malfunction. AN/GRC-103(V)4, Radio Set is used for operation in Line-of-Sight applications and has a frequency range of 1350 to 1850 megahertz with a transmission range of approximately 30 miles. The High Mobility DGM Assemblage (HMDA) 173B utilizes the S-805/G shelter mounted on the M1113 Expanded Capacity HMMWV. A second M1113 transports the AB-1373 30 meter antenna masts. A cargo trailer is provided for transport of ancillary items. 10 Kw power is supplied by an on-board APU or a towed PU-798.



AN / TRC - 173 / A

TRANSPORTATION CHARACTERISTICS / LIMITATIONS: AN/TRC-173 and AN/TRC-173A roll-on/roll-off for C-5 only. AN/TRC-173B roll-on/roll-off capability for C-130, C-141, C5 aircraft.

HISTORICAL BACKGROUND:

1980 DT/OT-II.
1982 Army initiated production efforts with TOAD.
Feb 84 TOAD First Article Tests (mechanical, electrical) completed.
Aug 85 Production contract awarded to Laguna Industries Incorporated.
Oct 87 FOT&E completed; Awarded FY88 Production Option to Laguna Industries.
Jul 89 Awarded downsized Production contract to Laguna Industries.
Mar 93 HMDA contract initiated.
Aug 94 HMDA follow-on production contract awarded.

REQUIREMENTS DOCUMENT: HQDA Letter Requirement, 19 Mar 76.

TYPE CLASSIFICATION: Standard A approved Jul 81; Updated by Materiel Status Record change May 90.

RELEASEABLE TO SECURITY ASSISTANCE CUSTOMERS: Yes

SYNOPSIS: AN/TRC-173() IS USED AS AN EXTENSION TERMINAL AT MAJOR NODES AND CONTAINS TWO LINE-OF-SIGHT TRANSMISSION SYSTEMS FOR ECHELONS ABOVE CORPS SIGNAL UNITS.

PM, WIN-T

AN/TRC-174(), RADIO REPEATER SET

PROJECT OFFICER: Ms. Noreen Polo,
DSN 992-3525
COMM 732/532-3525

ACQUISITION CATEGORY: III
ACQUISITION PHASE: MS III Production/Deployment

PE & LINE #:

DESCRIPTION: The -174 (Fullsize), -174A (Downsize) and -174B (HMDA) is used as an extension repeater at major nodes to provide up to 36 channels of digital trunk communications. AN/TRC-174() contains 3 complete communications systems housed in Shelter Facility. The AN/TRC-174() is composed of three AN/GRC-103(V)4 radio sets, one AN/VRC-46 or AN/VRC-90 radio, and portions of the Digital Group Multiplexer (DGM) family of equipment. The DGM equipment which is being utilized is as follows: MD-1026(P)/G, MD-1023(P)/G, MD-1065/G and Orderwire Control Unit C-10716/TRC. COMSEC equipment which includes the KY-57 VINSON and KY-68 DSVT is also included as part of the assemblage. Each of the three communication systems in the AN/TRC-174() is capable of full duplex operation (simultaneous send and receive). Under normal operating conditions, one system in the AN/TRC-174() assemblage remains in standby condition in the event of malfunction. Radio set AN/GRC-103(V)4 is used for operation in Line-of-Sight applications and has a frequency range of 1350 to 1850 megahertz with a transmission range of approximately 30 miles. The High Mobility DGM Assemblage (HMDA) -174B utilizes the S-805/G shelter mounted on the M1113 Expanded Capacity HMMWV. A second M1113 transports the AB-1373 30-meter antenna mast. A cargo trailer is provided for transport of ancillary items. 10 Kw power is supplied by an on-board APU or a towed PU-798.



TRANSPORTATION CHARACTERISTICS/LIMITATIONS: AN/TRC-174 and AN/TRC-174A roll-on/roll-off for C-5 only. AN/TRC-174B roll-on/roll-off capability for C-130, C-141, C-5 aircraft.

HISTORICAL BACKGROUND:

1980 DT/OT-II.
1982 Army initiated production efforts with TOAD.
Feb 84 TOAD First Article Tests (mechanical, electrical) complete.
Aug 85 Production contract awarded to Laguna Industries Incorporated.
Oct 87 FOT&E Completed; FY88 Production option awarded to Laguna Industries.
Aug 89 Downsized Production contract awarded to Laguna Industries.
Mar 93 HMDA Version Re-Packing Effort Initiated/Contract Modified.
Aug 94 HMDA Follow-on production contract awarded.

REQUIREMENTS DOCUMENT: HQDA Letter Requirement, 19 Mar 76.

TYPE CLASSIFICATION: Standard A approved Jul 81 IPR; Updated by Material Status Record change May 90.

RELEASEABLE TO SECURITY ASSISTANCE CUSTOMERS: Yes

SYNOPSIS: AN/TRC-174() IS USED AS AN EXTENSION REPEATER AT MAJOR NODES AND CONTAINS THREE LINE-OF-SIGHT TRANSMISSION SYSTEMS FOR ECHELONS ABOVE CORPS SIGNAL UNITS.

PM, WIN-T

AN/TRC-175()

PROJECT OFFICER: Ms. Noreen Polo,
DSN 992-3525
COMM 732/532-3525

ACQUISITION CATEGORY: III
ACQUISITION PHASE: MS III Production/Deployment

PE & LINE #:

DESCRIPTION: The AN/TRC-175(Fullsize), 175A (Downsize), and 175B (HMDA) are used at major switching nodes to transmit/receive trunk groups with the associated radio park. AN/TRC-175() contains two complete communication systems housed in a shelter facility. AN/TRC-175() is composed of two AN/GRC-222 radio sets, one AN/VRC-46 or AN/VRC-90 radio, and portions of the DGM family of equipment. The DGM equipment which is being utilized is as follows: MD-1026(P)/G, MD-1024/G, TD-1237(P)/G and Orderwire Control Unit C-10717/TRC. COMSEC equipment which includes the KY-57 VINSON and KY-68 DSVT is also included as part of the assemblage. Each of the two communication systems in the AN/TRC-175() is capable of full duplex operation (simultaneous send and receive). Radio Set AN/GRC-222 is used as a radio link to the AN/TRC-138A/138B located at the radio park and has a frequency range of 4.4 to 5.0 gigahertz with a transmission range of approximately five miles for the 18.72 megabits per second data rate and 25 miles for the 9.36 megabits per second data rate. The High Mobility DGM Assemblage (HMDA) - 175B utilizes an S-805/G shelter mounted on an M1113 Expanded Capacity HMMWV. A second M1113 transports the AB-1373 30-meter antenna mast. A cargo trailer is provided for transport of ancillary items. 10 Kw power is supplied by an on-board APU or a towed PU-798.

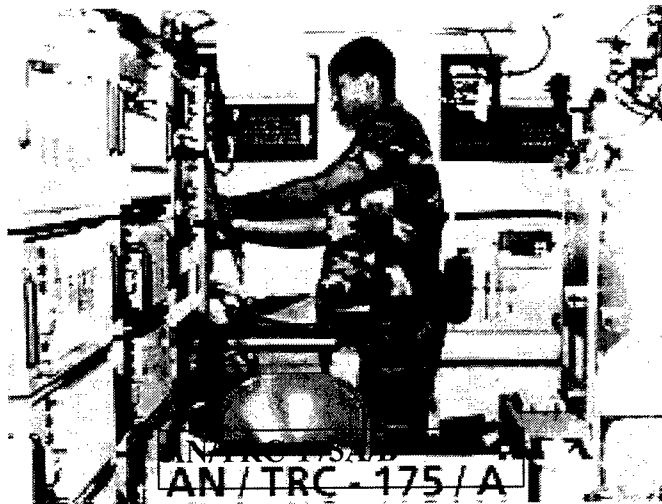

TRANSPORTATION CHARACTERISTICS / LIMITATIONS: AN/TRC-175 and AN/TRC-175A roll-on/roll-off for C-5 only.
AN/TRC-175B roll-on/roll-off capability for C-130, C-141, C-5 aircraft.

HISTORICAL BACKGROUND:

1980 DT/OT-II.
1982 Army initiated production efforts with TOAD.
Feb 84 TOAD First Article Tests (mechanical, electrical) completed.
Aug 85 Production contract awarded to Laguna Industries.
Oct 87 FOT&E completed; FY88 Production option awarded to Laguna Industries.
Jul 89 Downsized Production contract awarded to Laguna Industries.
Mar 93 HMDA Variant Version Re-Packing Effort Initiated/Contract Modified.
Aug 94 HMDA follow-on production contract awarded.

REQUIREMENTS DOCUMENT: HQDA Letter Requirement, 19 Mar 76.

TYPE CLASSIFICATION: Standard A approved Jul 81; Updated by Material Status Record change May 90.

RELEASEABLE TO SECURITY ASSISTANCE CUSTOMERS: Yes

SYNOPSIS: AN/TRC-175() IS A BOTTOM-OF-THE-HILL RADIO TERMINAL UTILIZED AT RADIO PARK TO TRANSMIT/RECEIVE TRUNK GROUPS AND CONTAINS TWO LINE-OF-SIGHT TRANSMISSION SYSTEMS FOR ECHELONS ABOVE CORPS SIGNAL UNITS.

PM, WIN-T

**AN/TTC-39, AN/TTC-39A, AN/TTC-39D,
CIRCUIT SWITCH**

PROJECT OFFICERS: William Blair and Lenzy Kelley,
DSN 992-8078
COMM 732/532-8078

ACQUISITION CATEGORY: III
ACQUISITION PHASE: MS IV Operations/Support

PE & LINE #: 1X428010.D107



DESCRIPTION: The AN/TTC-39A Circuit Switch is a 744 line mobile, automatic, modular, electronic telephone switch which operates under the control of a central processor. It is configured in a single shelter with integral COMSEC and multiplex equipment. The minimum essential control functions for the AN/TSQ-111 have been inherently designed into the electronics. The AN/TTC-39A is compatible with and interface to the Defense Communications System, NATO Integrated Communication System, Allied Organic Combat Communications System and the tactical communication systems of the services. AN/TTC-39D is an all digital configuration providing service for 708 terminations. It provides flood search routing capability using the MSE routing subsystem, interface capability for the MSE Radio Access Unit (RAU), and analog capability using the Digital Line Termination Unit (DLTU). A Joint Service effort to transport the functions of the Routing Subsystem to the switch central processor has been completed. This new capability provides a common software package for the AN/TTC-39D, AN/TTC-39AV ¾, MSE AN/TTC-46, AN/TTC-47, AN/TTC-51, DS, CDS, and SMU.

TRANSPORTATION CHARACTERISTICS / LIMITATIONS: 39A and 39D are housed in S-280 shelters (625 cu ft). No transportation limitations.

HISTORICAL BACKGROUND:

- Sep 89 AN/TTC-39D Production option award (23 kits).
- Sep 90 AN/TTC-39D Production option award (11 kits).
- Feb 92 AN/TTC-39D Production option award (12 kits).
- Apr 93 Fielding of First AN/TTC-39D with packet switching.
- Jul 93 NRE for 390 routing improvements awarded.
- Sep 95 Initial Circuit Switch Routing Tests user test.
- Apr 96 CSR TEP Program stoppage.
- Jun 96 CSR TEP Program restart.
- Sep 96 Joint User Switch Test.
- Jan 97 Last AN/TTC-39D fielded to Panama.
- Aug 97 Final CSR AN/TTC-39D Retrofit.

REQUIREMENTS DOCUMENT:

TYPE CLASSIFICATION: ASARC-III, Jun 80, Standard.

RELEASEABLE TO SECURITY ASSISTANCE CUSTOMERS: Yes

<u>EVENT SCHEDULE</u>	<u>FISCAL YEAR</u>		97	98	99	00	01	02
	<u>QTR</u>		1 2 3 4	1 2 3 4	1 2 3 4	1 2 3 4	1 2 3 4	1 2 3 4
Routing Improvements/GTE Production			-----4					
DIT/JUSE Routing Improvement			4					
ESOP Upgrades initiated			1					

SYNOPSIS: AN/TTC-39 IS A MOBILE, AUTOMATIC, MODULAR ELECTRONIC CIRCUIT SWITCH UNDER PROCESSOR CONTROL WITH INTEGRAL COMSEC AND MULTIPLEX EQUIPMENT. AN/TTC-39A PRODUCTION IMPROVEMENT ADDS NODAL CONTROL CAPABILITY TO THE CIRCUIT SWITCH. AN/TTC-39D PRODUCT IMPROVEMENT ADDS MSE FLOOD SEARCH CAPABILITY TO THE CIRCUIT SWITCH.

PM, WIN-T

**AN/TYQ-30(V)1, (V)2, and AN/TYQ-31,
COMMUNICATION SYSTEM CONTROL
ELEMENT (CSCE)**

PROJECT OFFICER: Mr. Luis Antomattei,
DSN 992-1733
COMM 732/532-1733

ACQUISITION CATEGORY: III
ACQUISITION PHASE: MS IV Operations/Support

PE & LINE #: 1X428010.D107

DESCRIPTION: The CSCE is the principal element of the system management and control hierarchy for the tactical switched network in Echelons Above Corps (EAC). CSCE is a heirarchical system that includes the following three components: AN/TYQ-30(V)1 used by Signal Brigades; AN/TYQ-30(V)2 used by Signal Battalions; AN/TYQ-31 used by Signal Companies. It will exercise near real-time control over the allocation and use of resources within its assigned portion of the deployed tactical communications network. CSCE is an evolutionary program. The software is segmented into discrete and demonstrable "phases". The hardware is an NDI procurement. Software incorporates "off-the-shelf" software (e.g., VMS, ORACLE, PASSPORT, GRAPHICS) and new software written in HOL. Hardware is Microvax based with Government Furnished Equipment (e.g., DSVTs, DSDIs, DGM).

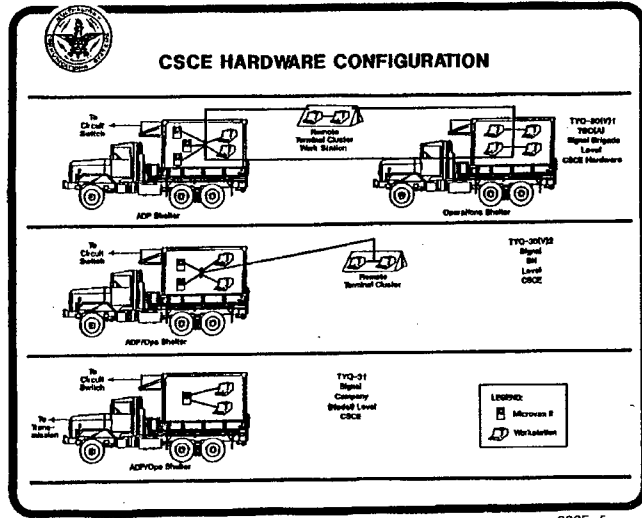

TRANSPORTATION CHARACTERISTICS / LIMITATIONS: Shelters have to be removed from truck for air transport on C-130 and C-141 aircraft.

Problem Item(s) Model Lin	Operational Length / Width / Height (inches)	Maximum Reduced (For Shipping) L / W / H / In	Shipping Weight (Lbs)	Operational Weight (Lbs)	Operational Volume (Cu Ft)	Reduced (shipping volume) (Cu Ft)
S-280 shelter TYQ-30 (V)1, (V)2, TYQ-31	191.6 / 87 / 86.7	191.6 / 87 / 86.7	6,633.8 / 6,533 / 6107	6,433.8 / 6,333 / 5,907	836.4	836.4
S-713 shelter OPS	211.6 / 87 / 89.3	211.6 / 87 / 89.3	5,807.3	5,601.3	951.4	951.4
M923A2 5 ton Truck	310.5 / 121 / 121	310.5 / 97.4 / 93.9	20,930	20,930	2,630.8	1,643.4
PU-406 Generator Set on 2 1/2 Ton M200A1 trailer chassis	185.88 / 95.5 / 87.0	166.38 / 95.5 / 87.0	6,380	6,380	893.74	799.98
S-280 shelter M923A2 truck	310.5 / 121 / 145.0			27,563.8	3,152.6	
S-713 shelter M923A2 truck	310.5 / 121 / 147.6			26,737.3	3,209.1	
S-280 shelter M923A2 truck towing PU-406	476.88 / 121 / 145.0			33,943.8	4,841.9	
S-713 shelter M923A2 truck towing PU-406	476.88 / 121 / 147.6			33,117.3	4,928.8	

HISTORICAL BACKGROUND:

Feb 83	Air Force transfers program to Army.	Mar 92	Fielding to ISC.
Feb 87	Production contract restarted, all protests denied.	Feb 93	Fielding to EUSA.
Sep 87	Awarded Follow-On Software Development contract to GTE.	Mar 94	Fielding INMS Version 2.3
Aug 90	User Test conducted.	Oct 95	Fielding INMS Version 2.4
Feb 92	Fielding to Germany completed.	Mar 96	All fielding completed.

REQUIREMENTS DOCUMENT: Joint Service Operational Requirement (JSOR) Jul 1994. (SM 393-74).

TYPE CLASSIFICATION: Standard approved Nov 90, Special IPR.

RELEASEABLE TO SECURITY ASSISTANCE CUSTOMERS: Yes

EVENT SCHEDULE	FISCAL YEAR	97	98	99	00	01	02
		1 2 3 4	1 2 3 4	1 2 3 4	1 2 3 4	1 2 3 4	1 2 3 4
INMS Testing Version 2.5		2					
Hardware Transition to CECOM		2					

SYNOPSIS: CSCE IS USED TO AUTOMATE CONTROL OF THE TRI-SERVICE TACTICAL COMMUNICATION SYSTEM (TRI-TAC), A COMPLEX NETWORK COMMUNICATION EQUIPMENT AND SOFTWARE. THE CSCE ENHANCES THE ARMY'S ABILITY TO COMMUNICATE ACROSS A WIDELY DISPERSED AND DISTRIBUTED BATTLEFIELD AND TO ESTABLISH AN EFFECTIVE AND INTEGRATED COMMUNICATION NETWORK.

PM, WIN-T

ARMY KEY MANAGEMENT SYSTEM (AKMS)

PROJECT OFFICER: Mr. John Skrletts,
 DSN 992-5988
 COMM 732/532-5988
 FAX: 732/532-5485
 E-Mail: skrletts@doim6.monmouth.army.mil

ACQUISITION CATEGORY: III
ACQUISITION PHASE: MS II / III EMD/Production

PE & LINE #: 0303140A.D501

DESCRIPTION: AKMS is the combination of several programs to integrate all functions of COMSEC key management and frequency management into one system. These systems were formally known as Revised Battlefield Electronic CEOI System (RBECS), Automated COMSEC Management And Engineering System (ACMES), and Army Electronic Generation and Distribution System (AEGADS). The combined system is designed to meet the critical requirement to decentralize and automate the processes required to generate and distribute data required by communications systems. Data includes COMSEC Keys, EP fill and CEOI. It will be more responsive to rapidly changing and highly mobile battlefield conditions as an integral system used with SINCGARS, MSE, EAC COMMS, JTIDS, EPLRS and other systems. The AKMS system is composed of workstation, a Common Tier 3 (CT3) on the Data Transfer Device (DTD). Local COMSEC Management Software (LCMS), Revised Battlefield Electronics CEOI software, and COMSEC net planning software. The workstation software is hosted on the Lightweight Computer Unit (LCU) and includes the Key Processor (KOK-22) and a printer as peripherals. The CT3 is a tri-service unique application software hosted on the NSA developed Data Transfer Device (AN/CYZ-10). AKMS will eliminate the use of paper CEOIs and hard copy key and will provide greater flexibility and security to user units. It will be used by all combat, combat support, combat service support units.

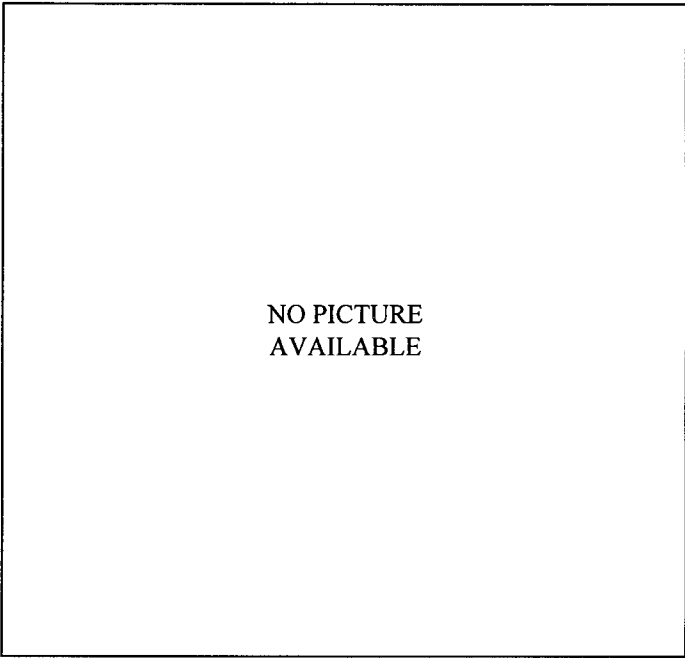

TRANSPORTATION CHARACTERISTICS / LIMITATIONS: None.

HISTORICAL BACKGROUND:

- May 91 ACMES and Battlefield Electronics CEOI System (BECS) programs combined.
- Dec 91 ACMES program transitioned to PM MSCS.
- Apr 93 ACMES Phase I milestone IIIb accomplished.
- Apr 93 ACMES and AEGADS programs consolidated.
- Jun 93 ACMES Phase I fielding started.

REQUIREMENTS DOCUMENT:

TYPE CLASSIFICATION: Standard, Apr 93.

RELEASEABLE TO SECURITY ASSISTANCE CUSTOMERS: Yes

<u>EVENT SCHEDULE</u>	FISCAL YEAR QTR	97	98	99	00	01	02
		1 2 3 4	1 2 3 4	1 2 3 4	1 2 3 4	1 2 3 4	1 2 3 4
AKMS Phase I Fielding		-----4					
IOT&E Phase II		4					
Phase II Fielding			4--	-----4			
Milestone III Phase II			2				
Phase II IOC				2			

SYNOPSIS: AKMS IS THE COMBINATION OF SEVERAL PROGRAMS TO INTEGRATE ALL FUNCTIONS OF COMSEC KEY MANAGEMENT AND FREQUENCY MANAGEMENT INTO ONE SYSTEM.

PM, WIN-T

ASYNCHRONOUS TRANSFER MODE (ATM)

PROJECT OFFICER: Joanne Powell,
DSN 992-6021
COMM 732/532-6021
FAX: DSN 992-2654

ACQUISITION CATEGORY: III
ACQUISITION PHASE: MS III Production/Deployment

PE & LINE #: BB1610 & BB1611

DESCRIPTION: As part of the Tactical Switching Modernization Program, a new switching technology known as ATM will be incorporated into tactical circuit switches. The ATM upgrade will provide for expanded data capacity and tactical video. The tactical circuit switches to be upgraded include most of the AN/TTC-39 A/D and Mobile Subscriber Equipment (MSE) families of switches.

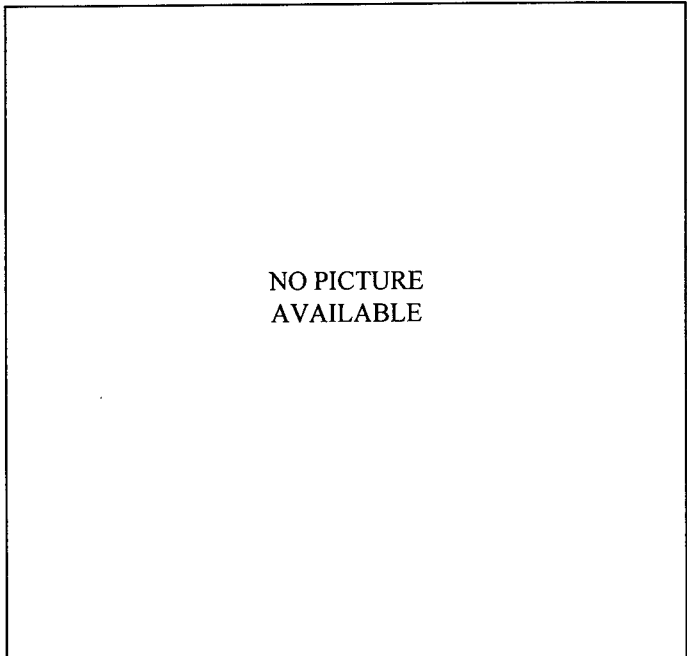

TRANSPORTATION CHARACTERISTICS / LIMITATIONS: None due to ATM.

HISTORICAL BACKGROUND:

Oct 96 Awarded contract to GTE Government Systems Corporation for Non-Recurring Engineering (NRE) and division "Slice" production on a not-to-exceed basis which was negotiated and definitized by 31 Jul 97.

REQUIREMENTS DOCUMENT: US Army Warfighter Information Network (WIN) Implementation Plan and Army Common User System Modernization Plan (ACUS MP).

TYPE CLASSIFICATION: All switches involved are type classified standard.

RELEASEABLE TO SECURITY ASSISTANCE CUSTOMERS: Yes

<u>EVENT SCHEDULE</u>	<u>FISCAL YEAR</u>		97	98	99	00	01	02
	<u>QTR</u>		1 2 3 4	1 2 3 4	1 2 3 4	1 2 3 4	1 2 3 4	1 2 3 4
NRE/Division Slice	1-----				1			
Follow-on Production				3----				

SYNOPSIS: ATM REPRESENTS NEW SWITCHING TECHNOLOGY FOR TACTICAL CIRCUIT SWITCHES.

PM, WIN-T

DOWN SIZED CSCE (D/S COMM SYSTEMS CONTROL ELEMENT) (ISYSCON-EAC)



PROJECT OFFICER: Mr. Mike Hromoko,
DSN 992-3473
COMM 732/532-3474

Mr. Luis Antomattei,

DSN 992-1733
COMM 732/532-1733



ACQUISITION CATEGORY: III
ACQUISITION PHASE: II



PE & LINE #: See related ISYSCON Program (BX0007)

DESCRIPTION: The ISYSCON (EAC) is the principal element of the system management and control hierarchy for the tactical switched network in Echelons Above Corps (EAC). It provides fully integrated network management capability with common hardware and software baseline at all echelons. The ISYSCON (EAC) is a hierarchical system that includes Signal Brigades, Signal Battalions, and Signal Company levels. It will exercise near real-time control over the allocation and use of resources within its assigned portion of the deployed tactical communications network. The D/CSCE effort consists of the fabrication of facilities. These facilities will be equipped with ADP and other associated equipment to upgrade to make it an ISYSCON (EAC) System.

TRANSPORTATION CHARACTERISTICS / LIMITATIONS: The D/CSCE configuration consists of an S-250 shelter mounted on a HMMWV*(M-1097) with a trailer mounted PU-798 generator. There are no limitations with this configuration.

HISTORICAL BACKGROUND:

Aug 94 Contract award for development and First Article Testing of 3 FAT systems.
Oct 95 Contract award for ISYSCON (EAC) Requirements.

REQUIREMENTS DOCUMENT:

TYPE CLASSIFICATION:

RELEASEABLE TO SECURITY ASSISTANCE CUSTOMERS: Yes

<u>EVENT SCHEDULE</u>	<u>FISCAL YEAR</u>		97	98	99	00	01	02
	<u>QTR</u>		1 2 3 4	1 2 3 4	1 2 3 4	1 2 3 4	1 2 3 4	1 2 3 4
Production Contract Award				1				
First Article testing of 3 Prototype Systems				3				
First Unit Equipped					4			

SYNOPSIS: D/CSCE IS USED TO AUTOMATE CONTROL OF THE TRI-SERVICE TACTICAL COMMUNICATION SYSTEM (TRI-TAC). A COMPLEX NETWORK COMMUNICATION EQUIPMENT AND SOFTWARE. THE CSCE ENHANCES THE ARMY'S ABILITY TO COMMUNICATE ACROSS A WIDELY DISPERSED AND DISTRIBUTED BATTLEFIELD AND TO ESTABLISH AN EFFECTIVE AND INTEGRATED COMMUNICATION NETWORK.

PM, WIN-T

**DIGITAL GROUP MULTIPLEXER ANTENNA
MAST PROGRAM (DAMP)**

PROJECT OFFICER: Mr. Jorge Tersy,
DSN 992-9651
COMM 732/532-9651

ACQUISITION CATEGORY: III
ACQUISITION PHASE: MS III Production/Deployment

PE & LINE #:

DESCRIPTION: AB-1373/TRC is a 30 meter antenna mast with an electronic antenna positioner used to support the AN/TRC-138A, B, C, AN/TRC-173(), AN/TRC-174(), and AN/TRC-175(), DGM Assemblages. In the full-sized version, the mast is transported in a pallet mounted on a M-1061A1 trailer with two MEP-003A generators. In the downsized version, the same pallet is mounted on the back of a 5-ton truck with the downsized S-749 DGM shelter and an MJQ-18 Power unit is towed. In the High Mobility DGM Assemblage (HMDA) version, a new antenna pallet was designed for the M1113 Expanded Capacity Vehicle. The 174 and 138 assemblages use three AB-1373s and the 173 and 175 use two AB-1373s.

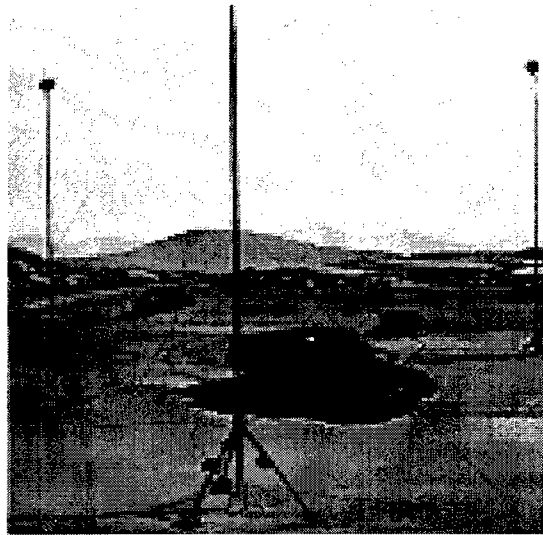

TRANSPORTATION CHARACTERISTICS / LIMITATIONS: None.

HISTORICAL BACKGROUND:

Jul 86 Signal Center General Officer Meeting decided the AB-1309/TRC Antenna Mast would no longer be fielded with DGM assemblages but instead as an auxiliary mast system. The DGM Assemblage Mast Program will provide an objective antenna mast system for DGM assemblages.
Dec 88 DA direction to proceed with 30M Mast Procurement.
Feb 90 Contract (basic) awarded.
May 91 FAT completed.
Jul 92 First Unit Equipped (FUE). Conditional Release to Korea.
Jul 93 Full Materiel Release.

REQUIREMENTS DOCUMENT: DGM JSOR, Dec 74.

TYPE CLASSIFICATION: Standard (DGM) approved Aug 81; Updated by Materiel Status Record Change 1991.

RELEASEABLE TO SECURITY ASSISTANCE CUSTOMERS: Yes

SYNOPSIS: DAMP PROVIDES ANTENNA MASTS IN SUPPORT OF THE DGM ASSEMBLAGES.

PM, WIN-T

INTEGRATED SYSTEMS CONTROL (ISYSCON)

PROJECT OFFICER: John J. Nunziato,
DSN 992-1253
COMM 732/532-1253

ACQUISITION CATEGORY: III
ACQUISITION PHASE: MS II Eng/Manufacturing Dev

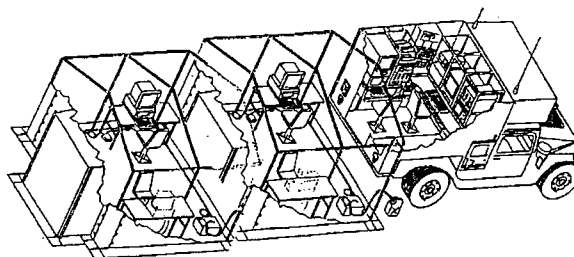

PE & LINE #: 248010 D107; BX0007 (See also related programs for DS/CSCE and NMT modernization).

DESCRIPTION: The ISYSCON provides an automated, theatre-wide system that Signal Units will use to manage multiple tactical communications systems in support of battlefield operations. The ISYSCON facility will provide an automated, integrated method for managing the tactical communications networks and interface with each battlefield functional area in the Army Tactical Command and Control system (ATCCS) architecture. A change to the requirements document has added planning and management of MILSATCOM resources. The ISYSCON has been selected as the communications network planning and management system for joint task force use. The spectrum management software has been designated as part of the migration system for DOD use. An ISYSCON node consists of a shelter on a HMMWV and two extension tents, two server and four client workstations, and peripherals. An ISYSCON node can support up to 20 remote terminals distributed by the S3 to various signal officers. (Each ISYSCON node will be provided with 10 remote terminals).

TRANSPORTATION CHARACTERISTICS / LIMITATIONS: HMMWV mounted with roll-on/roll-off capability. No limitations.

HISTORICAL BACKGROUND:

- Nov 90 ROC approved.
- Jun 91 PM, JTACS assigned management responsibility.
- Nov 91 Acquisition Plan approved; Milestone I/II IPR.
- Sep 92 EMD Contract Award.
- Dec 92 Protest resolved.
- Nov 93 ISYSCON selected for Joint Task Force use as a Joint Communications Planning/Management System.
- May 94 ROC Amended.
- Nov 94 User Functional Description.
- May 95 LRIP Decision.
- Nov 95 System specification SS-2756500.

REQUIREMENTS DOCUMENT: ROC signed 19 Dec 90; Change dated 12 May 94, Sig Ctr reprioritizing of ISYSCON dated 12 Mar 97.

TYPE CLASSIFICATION: (Generic) Dec 94.

RELEASEABLE TO SECURITY ASSISTANCE CUSTOMERS: Yes

<u>EVENT SCHEDULE</u>	<u>FISCAL YEAR</u>																							
	97				98				99				00				01				02			
	QTR				1 2 3 4				1 2 3 4				1 2 3 4				1 2 3 4				1 2 3 4			
PI & DPR	1																							
PI FUE	2																							
P2 DPR	3																							
P3 DPR					3																			
PI Plus IOT&E					2																			
P2 FOT&E									2															

SYNOPSIS: THE ISYSCON WILL PROVIDE THE SIGNAL COMMAND & STAFF WITH AN INTEGRATED AUTOMATED PLANNING & CONTROL CAPABILITY TO ASSIST IN MANAGING COMMUNICATION SYSTEMS IN SUPPORT OF COMBAT FORCES, WEAPONS SYSTEMS, & BATTLEFIELD AUTOMATED SYSTEMS. IT WILL FUNCTION AS THE BATTLEFIELD SIGNAL MANAGEMENT SYSTEM AT DIVISION THROUGH THEATER/ECHELONS OR IN SUPPORT OF INDEPENDENT TASK FORCE OPERATIONS.

MOBILE SUBSCRIBER EQUIPMENT (MSE)

PROJECT OFFICER: William Benson,
DSN 992-5514
COMM 732/532-5514

ACQUISITION CATEGORY: III
ACQUISITION PHASE: MS III Production/Deployment

PE & LINE #: SSN: BB1610 & BB1611

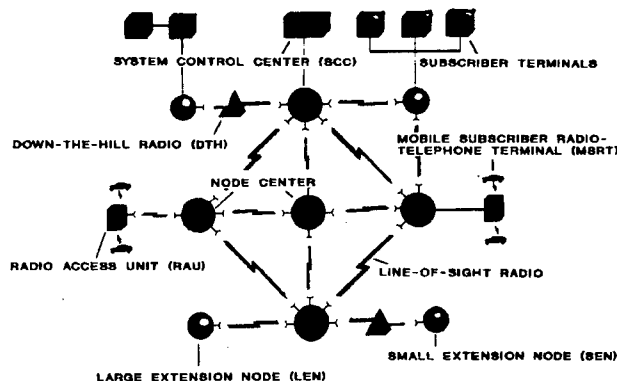

DESCRIPTION: The MSE system provides the tactical force with increased mobility and a discrete address capability to the user. The functions of switching, radio trunking, communications security and system control are integrated into one composite system, which replaces the existing command and area communications system in both the division and corps areas of operation. The MSE system provides users with a means of communicating throughout the battlefield, regardless of location, in either a static or mobile situation. The system significantly reduces the need to install wire and cable when establishing command posts. It provides telephone-like, full-duplex operation for massed or dispersed command posts. The MSE system consists of five major hardware functional elements: subscriber terminals; multiple subscriber access; wire subscriber access; area coverage; and system control. The Circuit Switch Routing Improvement and ESOP/Global upgrades provide increased Joint interoperability, reliability, seamless operation and improved soldier-machine interface.

TRANSPORTATION CHARACTERISTICS / LIMITATIONS: None.

HISTORICAL BACKGROUND:

- | | | | |
|--------|---|--------|---|
| Oct 79 | Joint Operational Requirement approved. | Nov 89 | TEMP approved. |
| Nov 83 | Under Secretary of the Army directed MSE be procured using a non-developmental acquisition approach. | Oct 90 | 1st MSE equipped III Corps deployed to SWA Theater of Operations; Dual LKG contract modification award. |
| | Battlefield Communications Review determined MSE will be deployed throughout the Corps and Divisions of Army. | May 83 | Acquisition Plan approved. Sep 83 |
| Dec 85 | Contract award (basic); Contract award (1st option). | Nov 90 | LCCP and ADI contract modifications award; VECP consolidated fielding contract modification award. |
| Feb 88 | FUE completed. | Dec 91 | MSE GOSC Review (Signal Architecture Review). |
| Oct 88 | FOTE completed. | Jul 93 | Negotiated GTE Global Settlement. |
| | | Nov 93 | Fieldings Completed. |
| | | May 94 | ESOP upgrade NRE TEP awarded. |
| | | Nov 95 | CSR TEP retrofit initiated. |
| | | Feb 97 | ESOP fieldings initiated. |

REQUIREMENTS DOCUMENT: MSE Operational Capability document approved by HQDA, 24 May 84.

TYPE CLASSIFICATION: Standard, Nov 85.

RELEASEABLE TO SECURITY ASSISTANCE CUSTOMERS: Yes

EVENT SCHEDULE	FISCAL YEAR							
	97				98	99	00	01
	QTR				1 2 3 4	1 2 3 4	1 2 3 4	1 2 3 4
ESOP/Global*	1							
Auto Combat Net Radio Interface*	2							
ESOP/Global option for Reserve Component Awarded	4							
NMT					2			
Tactical T1/E1*					2			

* Enhancement to MSE.

SYNOPSIS: MSE SYSTEM INTEGRATES THE FUNCTIONS OF THE USER TERMINAL EQUIPMENT, SWITCHING, RADIO TRANSMISSION, COMMUNICATIONS SECURITY & CONTROL INTO ONE COMPOSITE COMMUNICATIONS SYSTEM. WHEN FIELDIED, MSE REPLACED THE EXISTING SWITCHING COMMUNICATIONS SYSTEMS IN THE CORPS & DIVISION AREAS.

PM, WIN-T

NETWORK ENCRYPTION SYSTEM (NES)

PROJECT MANAGER: Mr. Thomas Crowe,
DSN 992-9355
COMM 732/532-9355

ACQUISITION CATEGORY: III
ACQUISITION PHASE: MS III Production/Deployment

PE & LINE #:

DESCRIPTION: The NES is an in-line encryption system. The NES is being fielded to allow SBU STAMIS users to use the Tactical Packet Network (TPN) as a transmission media. The NES will prevent interaction between STAMIS users and TPN subscribers. The NES is being fielded as an interim step until a single network capable of Multi-Level Security (MLS) can be implemented.

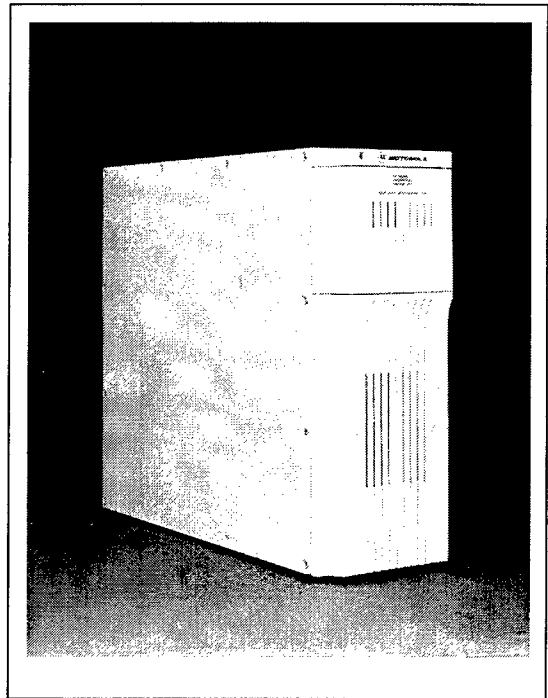

TRANSPORTATION CHARACTERISTICS / LIMITATIONS: The NES is rack mounted in a transit case.

HISTORICAL BACKGROUND:

Mar 96 DA Memorandum authorizing procurement.
Oct 96 MWO Release.
Nov 96 Fielding to 35th SIG BDE.

REQUIREMENTS DOCUMENT: DA Memorandum 28 Mar 96, Limited Procurement of NES Device.

TYPE CLASSIFICATION: Limited Procurement Urgent. Will be changed to Standard as of 1QFY98.

RELEASEABLE TO SECURITY ASSISTANCE CUSTOMERS: Yes

<u>EVENT SCHEDULE</u>	<u>FISCAL YEAR</u>						
	97	98	99	00	01	02	
	1 2 3 4	1 2 3 4	1 2 3 4	1 2 3 4	1 2 3 4	1 2 3 4	
NES Fieldings							

SYNOPSIS: NES ALLOWS SBU SUBSCRIBERS USE OF THE TPN BY ELECTRONIC SEPARATION FROM OTHER TPN SUBSCRIBERS.

PM, WIN-T

NETWORK MANAGEMENT TOOL (NMT)

PROJECT OFFICER: Mr. Joseph Schannen,
DSN 992-3110
COMM 732/532-3110
FAX: 732/532-5485
E-Mail: schannen@doim6.monmouth.army.mil

ACQUISITION CATEGORY:
ACQUISITION PHASE: MS III

PE & LINE #: See related ISYSCON Program (BX0007)

DESCRIPTION: The Network Management Tool (NMT) will provide the network management capability for the MSE network. The NMT will provide: network planning and engineering; battlefield spectrum management; network monitoring and control; equipment configuration and monitoring; and Signal Command and Control. The NMT replaces the System Control Center-2 (SCC-2) and the Network Planning Terminal (NPT) in the MSE network. The NMT will in turn be replaced by the ISYSCON, the objective network management system for the Army Common User System (ACUS). The NMT consists of a subset of the Common Hardware (CHS-2) and the software used in the ISYSCON.

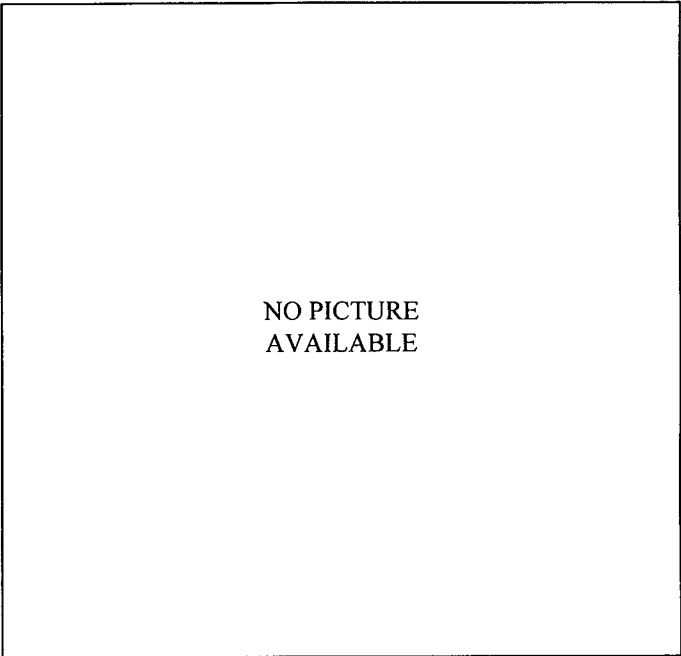

TRANSPORTATION CHARACTERISTICS / LIMITATIONS: S-250E Shelter on HHMWV. Full MSE mobility.

HISTORICAL BACKGROUND:

Dec 94 ECP700C2 Approved to upgrade SCC-2 to NMT.

REQUIREMENTS DOCUMENT:

TYPE CLASSIFICATION:

RELEASEABLE TO SECURITY ASSISTANCE CUSTOMERS: Yes

<u>EVENT SCHEDULE</u>	FISCAL YEAR	97	98	99	00	01	02
		QTR	1 2 3 4	1 2 3 4	1 2 3 4	1 2 3 4	1 2 3 4
PDT Assur. Test & Eval (PATE) Completed			1				
First Unit Equipped - Ft. Hood			2				

SYNOPSIS: THE NMT WILL BE THE NETWORK MANAGEMENT SYSTEM FOR THE MSE NETWORK. IT WILL BE BASED ON THE ISYSCON ARCHITECTURE AND WILL BE REPLACED BY ISYSCON.

PM, WIN-T

COMPACT DIGITAL SWITCH (ON-422)

PROJECT OFFICER: Mr. Ronald Testa,
DSN 987-3492
COMM 732/532-3492

ACQUISITION CATEGORY: III
ACQUISITION PHASE: Production/Operation/Support

PE & LINE #:

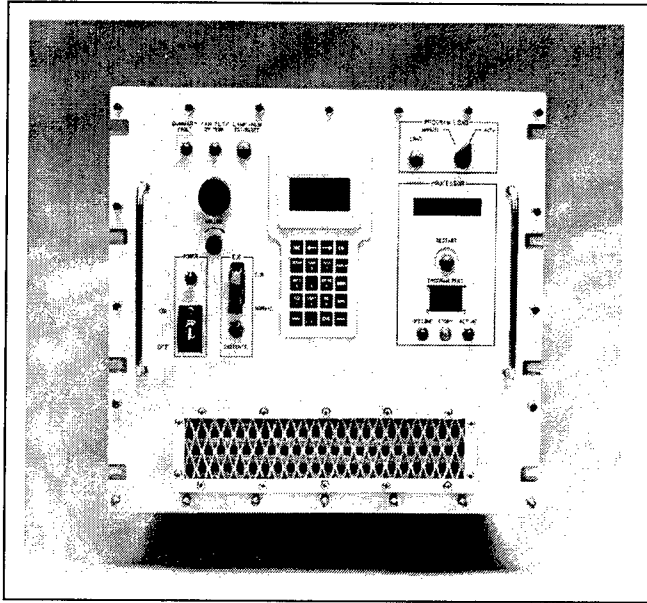

DESCRIPTION: The ON-422 is a 708 line circuit switch that provides switching multiplexing and COMSEC capability in a small and lightweight chassis assembly. Coupled with ancillary items, including a call service position, line termination unit, and rubidium timing standard, all operational features performed by the larger AN/TTC-39D are achievable. Enhancements include T1 and E1 commercial interfaces. VTC function is supported via a high speed MUX capability.

TRANSPORTATION CHARACTERISTICS / LIMITATIONS: The CDS is currently delivered for shelter or rack mounting in a mobile or fixed environment.

HISTORICAL BACKGROUND:

- Jul 93 Initial contract awarded for production.
- Apr 94 Initial fielding of equipment.
- Mar 97 Award of follow-on production contract.

REQUIREMENTS DOCUMENT:

TYPE CLASSIFICATION:

RELEASEABLE TO SECURITY ASSISTANCE CUSTOMERS: Yes

<u>EVENT SCHEDULE</u>	FISCAL YEAR	97	98	99	00	01	02
		QTR	1 2 3 4	1 2 3 4	1 2 3 4	1 2 3 4	1 2 3 4
Follow on contract		2-----	-----	-----	-----		

SYNOPSIS: A 708 LINE CIRCUIT SWITCH THAT PROVIDES A COMPACT UNIT FOR INSTALLATION AS A SUBSYSTEM IN COMM ASSEMBLIES.

PM, WIN-T

SWITCH MULTIPLEX UNIT (SMU)

PROJECT MANAGER: Mr. George Brick,
DSN 992-9275
COMM 732/532-9275

ACQUISITION CATEGORY:
ACQUISITION PHASE:
Production/Operation/Support

PE & LINE #:

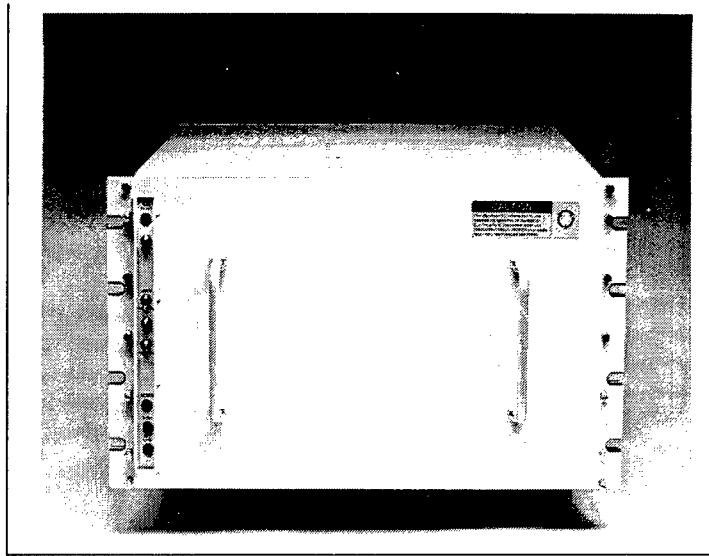

DESCRIPTION: The SMU is a 708 line circuit switch that combines the capabilities of the Compact Digital Switch (ON-422), Line Termination Unit (CV-4180) an anatomic timing standard source in a single chassis. The SMU will perform the features of the AN/TTC-39D. Enhancements include TI or EI commercial interfaces. VTC function is supported via a high speed MUX capability.

TRANSPORTATION CHARACTERISTICS / LIMITATIONS: The SMU is currently delivered for shelter or rack mounting in a mobile or fixed environment.

HISTORICAL BACKGROUND:

Apr 95 Initial contract awarded for production.
Mar 97 Award of follow-on production contract.

REQUIREMENTS DOCUMENT:

TYPE CLASSIFICATION:

RELEASEABLE TO SECURITY ASSISTANCE CUSTOMERS: Yes

<u>EVENT SCHEDULE</u>	<u>FISCAL YEAR</u>						
	97	98	99	00	01	02	
	1 2 3 4	1 2 3 4	1 2 3 4	1 2 3 4	1 2 3 4	1 2 3 4	
Follow on contract	2-----	-----	-----	-----	-----	-----	

SYNOPSIS: A 708 LINE CIRCUIT SWITCH THAT PROVIDES A COMPACT UNIT FOR INSTALLATION AS A SUBSYSTEM IN COMM ASSEMBLIES FOR WHICH WEIGHT AND SPACE ARE CRITICAL PARAMETERS.

PM, WIN-T

WARFIGHTER INFORMATION NETWORK (WIN) - TERRESTRIAL TRANSPORT (TT)

PROJECT OFFICER: Mr. John Geist,
 DSN 992-5987
 COMM 732/532-5987

ACQUISITION CATEGORY: Currently ACAT III (as of 5 DEC 96); current funding and scope of the WIN(T) program meets that of an ACAT I Program IAW DoD 5000.2-R part 1, 1.3.1 and is currently in Pre-ACAT1 status.

ACQUISITION PHASE: III – Production & Deployment

PE & LINE #:

Division Set -----	BB1600	Secure Terminal Equipment (STE) -----	BB1600
Switch Modernization -----	BB1600	Radio Access Unit (RAU) Range Extension ---	BB1600
Fiber Optics -----	BB1600	Airborne Repeater -----	BB1600
Radio Modernization -----	BB1600	WIN Spares -----	BB1600
Personal Communications System (PCS) ---	BB1600	Tactical Internet (TI) Manager -----	BB1600
Wireless Local Area Network (LAN) -----	BB1600	Training Device Upgrade -----	BB1600
Battlefield Video Teleconference (BVTC) -	BB1600	Defense Message System (DMS) in switches --	None
		DMS management functions -----	None

DESCRIPTION: The Warfighter Information Network (WIN) is a total system architecture that supports the requirements of the Digitized Force XXI. WIN is the architecture that will seamlessly link our diverse information resources into a network our warfighters can use on the 21st century's digitized battlefield. The components of the terrestrial portion of WIN are: (a) The Division Slice is the engineering effort to prove out the institutional upgrade of the legacy area common user system (ACUS) switches with Asynchronous Transfer Mode (ATM). (b) The Switch Modernization process/fields this capability throughout the Army. (c) Fiber Optic cable is a replacement for coaxial cable. (d) The Radio Modernization provides the increased transmission links between switches to move voice, data, video, collaborative planning, etc. on the digitized battlefield. (e) Personnel Communications Services (PCS) provides wireless voice to the Tactical Operations Center (TOC). (f) Wireless Local Area Network (LAN) provides wireless data connectivity to the Tactical Packet Network (TPN) and/or ATM network for applications requiring increased mobility and dispersion. (g) Battlefield Video Teleconferencing (BVTC) provides a standard video capability on the battlefield. (h) Secure Terminal Equipment (STE) is the replacement for the wireline KY-68. (i) Radio Access Unit (RAU) Range Extension increases the range for the current mobile telephone. (j) Airborne Repeater a part of PCS is a communications package for the fixed-wing unmanned airborne vehicle (UAV). (k) Tactical Internet Manager provides wide area network (WAN) management and services for the brigade and below portion of the tactical internet. (l) Defense Message System (DMS) extension into the tactical area. Also included are spares to support all upgrades and associated upgrades to the Training Devices.

TRANSPORTATION CHARACTERISTICS / LIMITATIONS:

HISTORICAL BACKGROUND: N/A

REQUIREMENTS DOCUMENT: Area Common User System Modernization Plan (ACUS-MP), signed March 1996 by US Army Signal Center and April 1996 by PEO-C3S

TYPE CLASSIFICATION:

RELEASEABLE TO SECURITY ASSISTANCE CUSTOMERS: Yes

<u>EVENT SCHEDULE</u>	<u>FISCAL YEAR</u>																			
	97				98				99				00				01			
	1	2	3	4	1	2	3	4	1	2	3	4	1	2	3	4	1	2	3	4
Division Slice	1-----				-----				--1											
Switch Mod					3-----				-----				-----				-----			
BVTC					TBD															
Radio Mod					3-----				-----				-----				-----			
WLAN					TBD															
RAU Range Ext					3-----				-----				-----				-----			
Fiber Optics					TBD															
TI Manager					3-----				-----				-----				-----			
Training Development Upgrade	-----4								1-----				-----4							

SYNOPSIS: THE WARFIGHTER INFORMATION NETWORK (WIN) IS A TOTAL SYSTEM ARCHITECTURE THAT SUPPORTS THE REQUIREMENTS OF THE DIGITIZED FORCE XXI.

PD, CTIS

PD, CTIS

**DIGITAL TOPOGRAPHIC SUPPORT SYSTEM
(DTSS) AN/TYQ-48**

PROJECT DIRECTOR: David Thacker,
DSN 328-6876
COMM 703/428-6876

ACQUISITION CATEGORY: III
ACQUISITION PHASE: MS III Production, Fielding/
Deployment, and Operational Support

PE & LINE #: 654716.D579

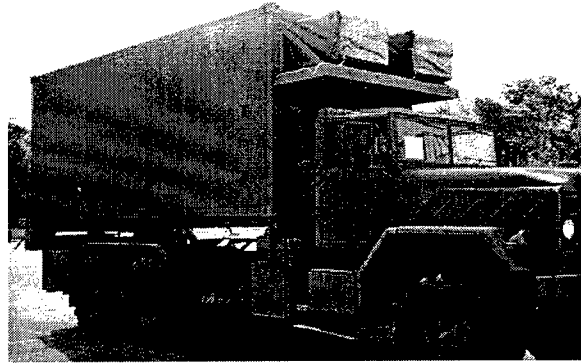

DESCRIPTION: The DTSS is a tactical, computer-based system which will provide automated assistance to the Army's terrain analysis function. It will have the capability to receive, reformat, create, store, retrieve, update, manipulate, and densify digital terrain data to produce terrain analysis products which contribute to the Intelligence Preparation of the Battlefield and support other tactical systems with digital terrain data and products. The DTSS consists of two terrain analysis workstations with associated equipment, housed in an S-280 shelter and mounted on an M-927 5-ton truck. The DTSS development will include a P3I program for the incorporation of technological improvements and interoperability with other PEO C3S systems. Included as a P3I is the requirement to exploit imagery. Part of imagery exploitation includes the development of a multispectral image processor (MSIP) which provides an image mapmaking capability. The DTSS program office was tasked with the mission to issue the DTSS-MSIP, as an interim measure, to Army topographic units. Delivery of the DTSS-MSIP's was completed in Jun 95. The development of an upgrade to incorporate the advanced reproduction (Low volume, large format, full color) capabilities of the Quick Response Multicolor Printer (QRMP) was completed in FY96. This upgrade includes incorporation of an ISO 20' shelter on a 5-ton vehicle and will replace existing DTSS systems. The upgraded system is referred to as the DTSS/QRMP-Heavy (H).

TRANSPORTATION CHARACTERISTICS / LIMITATIONS: C5/C141 Airlift Transportable.

HISTORICAL BACKGROUND:

- Apr 93 Milestone III decision, for DTSS.
- Jul 93 First LRIP Unit Delivered.
- Jun 94 DTSS FUE.
- Jun 94 Milestone III decision, for DTSS-MSIP.
- Jun 95 Complete Delivery of DTSS-MSIP's.
- Nov 95 Complete Delivery of DTSS LRIP units.
- Apr 96 Complete DTSS-MSIP Enhancements.
- Jul 96 Award DTSS/QRMP-H Production.

REQUIREMENTS DOCUMENT: DTSS ROC approved Oct 86, US Army TRADOC. DTSS/QRMP ORD Approved 20 Dec 94.

TYPE CLASSIFICATION: Standard, Apr 93.

RELEASEABLE TO SECURITY ASSISTANCE CUSTOMERS: No

<u>EVENT SCHEDULE</u>	<u>FISCAL YEAR</u>						
	97	98	99	00	01	02	
	1 2 3 4	1 2 3 4	1 2 3 4	1 2 3 4	1 2 3 4	1 2 3 4	
DTSS Upgrade	2-----	-----3					

SYNOPSIS: DTSS IS A TACTICAL, COMPUTER-BASED TERRAIN ANALYSIS SYSTEM WHICH WILL ENABLE THE TERRAIN ANALYST TO SUPPORT THE BATTLEFIELD COMMANDER WITHIN THE COMMANDER'S DECISION CYCLE.

PD, CTIS

**DIGITAL TOPOGRAPHIC SUPPORT SYSTEM/
QUICK RESPONSE MULTICOLOR PRINTER
(DTSS/QRMP) AN/TYQ-67(V)1**

PROJECT DIRECTOR: David E. Thacker,
DSN 328-6876
COMM 703/428-6876

ACQUISITION CATEGORY: III
ACQUISITION PHASE: MS II Eng/Manufacturing Dev

PE & LINE #: 654716.D579

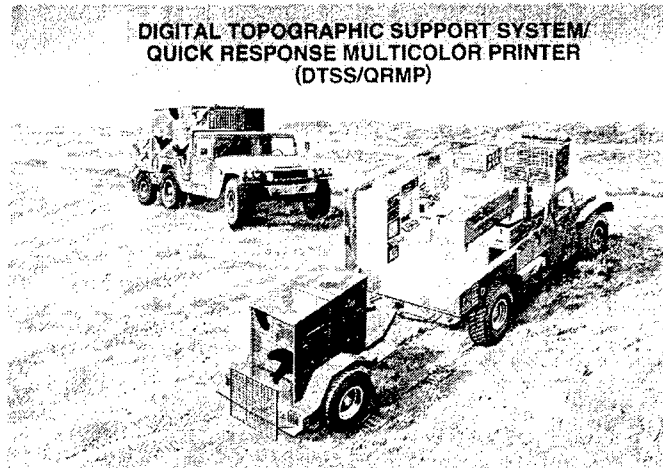

DESCRIPTION: The DTSS/QRMP is a tactically mobile computer-based system which will provide automated assistance to the Army's terrain analysis function. Combining the functionalities of the DTSS and QRMP into a downsized configuration will provide the commander with an automated process for Intelligence Preparation of the Battlefield, Terrain Visualization and analysis, and input to the Common Operating picture. The DTSS/QRMP will be a standard, automated, tactical combat support system capable of receiving, (re)formatting, creating, manipulating, merging, updating, storing, and retrieving digital topographic data, then reproducing this data into hardcopy topographic products. The DTSS/QRMP will accept topographic and multispectral imagery data from the National Imagery Mapping Agency (NIMA) standard digital data bases and from other sources. The system will be integrated into a Lightweight Multipurpose Shelter (LMS) mounted on the High Mobility Multipurpose Wheeled Vehicle (HMMWV). The DTSS/QRMP will be supported by environmental control units, generators, and communication equipment that are part of the standard Army inventory. A heavy (5-ton, ISO20 Foot Shelter) variant of the DTSS/QRMP will be provided as an upgrade to the original DTSS units.

TRANSPORTATION CHARACTERISTICS / LIMITATIONS: Has C-130 roll-on/roll-off capability. Requires one C-130 airlift per shelter/trailer for a total of two lifts for 100% capability.

HISTORICAL BACKGROUND:

Jan 93 SE&I Contract Award (Basic).

REQUIREMENTS DOCUMENT: DTSS/QRMP ORD, approved 20 Dec 94.

TYPE CLASSIFICATION: Standard, proposed.

RELEASEABLE TO SECURITY ASSISTANCE CUSTOMERS: No

EVENT SCHEDULE	FISCAL YEAR QTR	97	98	99	00	01	02
		1 2 3 4	1 2 3 4	1 2 3 4	1 2 3 4	1 2 3 4	1 2 3 4
Prototype Development		--1					
Combined DT/OT		2-----4					
Milestone III			1				
Production				1-----	-----	-----	-----

SYNOPSIS: DTSS/QRMP IS A TACTICAL, COMPUTER-BASED TERRAIN ANALYSIS AND LOW VOLUME REPRODUCTION SYSTEM WHICH WILL ENABLE THE TERRAIN ANALYST TO SUPPORT THE BATTLEFIELD COMMANDER WITHIN HIS DECISION CYCLE.

PEO IEW & S

PM, COMBAT ID

PM, COMBAT ID

BATTLEFIELD COMBAT IDENTIFICATION SYSTEM (BCIS)

PRODUCT MANAGER: LTC John Mahony,
DSN 987-5324
COMM 732/427-5324

ACQUISITION CATEGORY: II
ACQUISITION PHASE: MS II Eng/Manufacturing Dev

PE & LINE #: 64817 / D482

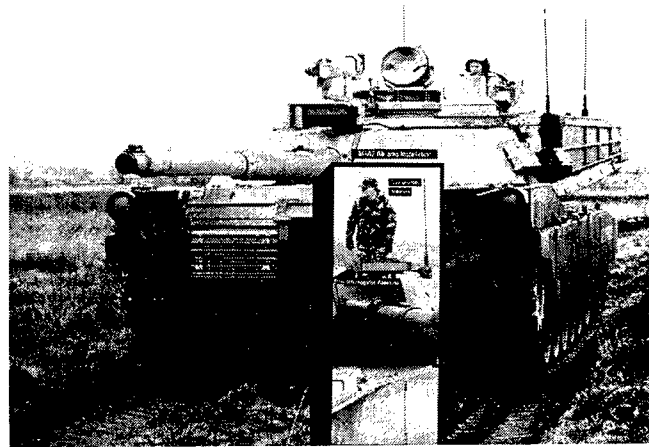

DESCRIPTION: The Battlefield Combat Identification System (BCIS) is an all-weather, day/night, millimeter wave, Low Probability of Intercept/Low Probability of Detection (LPI/LPD), digitally encrypted question and answer system that provides positive identification of friendly platforms out to 5.5 km (clear weather). BCIS was developed to minimize fratricide while maximizing combat effectiveness given the rapidly changing and intense tactical situations. BCIS provides positive identification of friendly platforms to aid the gunner or commander to make a rapid shoot/don't shoot decision at the point of engagement. BCIS also provides short range (out to 1 km, in clear weather), LPI/LPD situational awareness messages at the platoon level. Any situational awareness data received by BCIS will be sent to the Applique for integration with other position sources to form the full situation database.

TRANSPORTATION CHARACTERISTICS / LIMITATIONS: BCIS is a horizontal technology integration subsystem designed for application on selected warfighting platforms. The major BCIS components are the Communications LRU, Transponder Antenna, Display Interface LRU and the Interrogator Antenna. In total these weigh 18.9 lbs and occupy 560 cubic inches.

HISTORICAL BACKGROUND:

Jan 93 RFP Release.
Jul 93 MS II Decision Review.
Aug 93 Contract Award.
Jan 95 First Unit Delivered.

REQUIREMENTS DOCUMENT: CAPSTONE O&O Plan, 15 Jan 91. Joint MNS, Mar 92. ORD 14 Apr 93.

TYPE CLASSIFICATION: N/A

RELEASEABLE TO SECURITY ASSISTANCE CUSTOMERS: Yes

<u>EVENT SCHEDULE</u>	<u>FISCAL YEAR</u>											
	97		98		99		00		01		02	
	1	2	3	4	1	2	3	4	1	2	3	4
TF XXI Participation		2										
International Demo			3									
IOT						2						
MS III							4					

SYNOPSIS: BCIS IS A FAMILY OF ACTIVE TECHNOLOGY SOLUTIONS TO ELIMINATE BATTLEFIELD FRATRICIDE.

PM, COMBAT ID

**COMBAT IDENTIFICATION (CID) ADVANCED
CONCEPT TECHNOLOGY DEMONSTRATION
(ACTD)**

PRODUCT MANAGER: LTC John Mahony,
DSN 987-5324
COMM 732/427-5324
FAX: DSN 987-5962
E-Mail: mahony@doim6.monmouth.army.mil

ACQUISITION CATEGORY: N/A
ACQUISITION PHASE: Demo/Val

PE & LINE #: 62120/AH15 (Army)
63772/D281 (Army)
63750D (OSD)

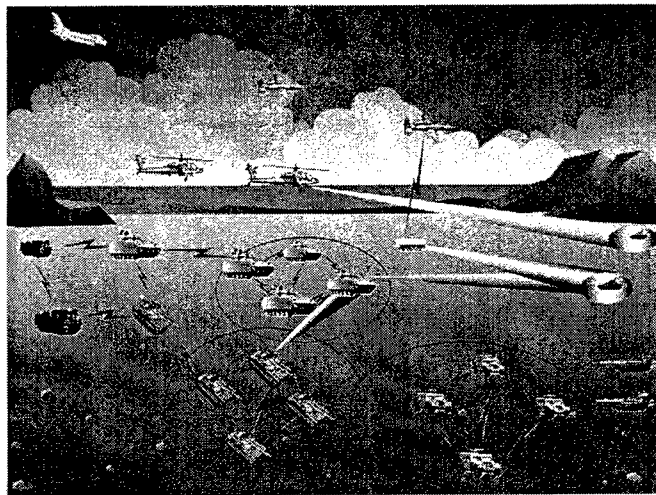

DESCRIPTION: No single CID system is associated with this phase of the CID ACTD. Instead, this ACTD investigates various technology concepts that show promise of reducing fratricide and increasing combat effectiveness. The CID ACTD is a jointly sponsored effort to demonstrate technology concepts to satisfy the critical mission need for an integrated air-to-ground and ground-to-ground CID capability. The CID ACTD includes assessment of "leave behind" systems for combat capabilities, as well as the assessment of alternative technologies. The CID ACTD will take advantage of service programs in target identification and situational awareness: for example, the Battlefield Combat Identification System (BCIS), Battlefield Digitization program, and the Single Channel Ground and Air Radio System (SINCGARS). One of the key evaluation venues was the Army Task Force XXI Army Warfighting Experiment (AWE).

TRANSPORTATION CHARACTERISTICS / LIMITATIONS:

Combat ID is a Horizontal Technology Integration program which will ultimately lead to systems that will be mounted on and become an integral part of the preponderance of ground and air tactical combat platforms to include helicopters and fixed-wing aircraft.

HISTORICAL BACKGROUND:

- Aug 92 Acquisition Decision Memorandum.
- Dec 92 Army Science Board Study.
- Apr 93 Combat Identification Operational Requirements Document.
- Aug 93 TRADOC Operational Concept.
- Jun 94 CID ACTD Proposal accepted by JROC.
- Nov 94 Vice Chairman, JCS Request for CID ACTD.

REQUIREMENTS DOCUMENT: CID ORD 14 Apr 93.

TYPE CLASSIFICATION: N/A

RELEASEABLE TO SECURITY ASSISTANCE CUSTOMERS: Yes

EVENT SCHEDULE	FISCAL YEAR											
	97		98		99		00		01		02	
	1	2	3	4	1	2	3	4	1	2	3	4
Complete HW/SW Development & Integration	-----4											
Task Force XXI at NTC	2											
CID Exercise (CIDEX)			1									
Virtual Integration Experiment (VIE)			1									
Leave-Behind Evaluation			1-----	-----4								

SYNOPSIS: CID ACTD INVESTIGATES VARIOUS TECHNOLOGY CONCEPTS THAT SHOW PROMISE OF REDUCING FRATRICIDE AND INCREASING COMBAT EFFECTIVENESS.

PM, COMBAT ID

COMBAT IDENTIFICATION DISMOUNTED SOLDIER (CIDDS)

PRODUCT MANAGER:

FAX: DSN 987-5270 COMM 732/427-5270

ACQUISITION CATEGORY: III

ACQUISITION PHASE: MS I/II

PE & LINE #: 64817/902

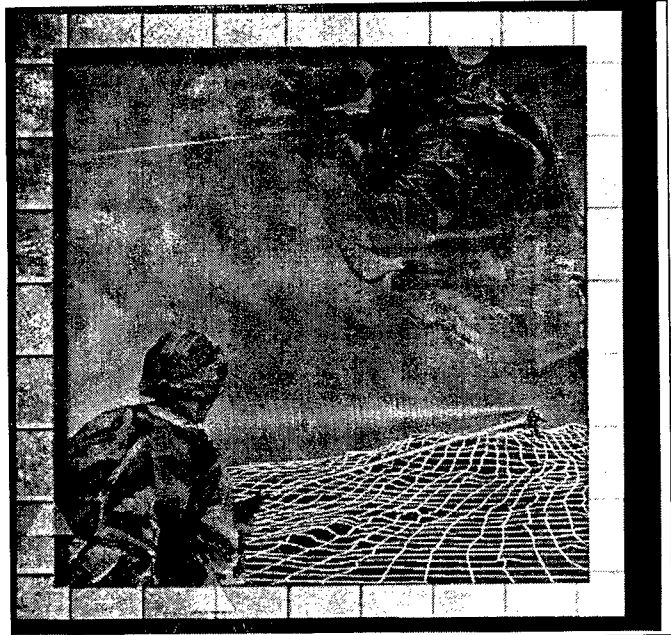

DESCRIPTION: The Combat Identification System for the Dismounted Soldier (CIDDS) is a lightweight, affordable, and supportable friend identification system. The system must include: combat identification, night target pointing capabilities, and interoperate with the Army's Tactical Engagement Simulation (TES) system. In addition, the stand alone CIDDS capability, being developed under this effort, will be interoperable with the Land Warrior (LW) embedded CIDDS capability, being developed under the Force XXI LW Science and Technology Program. The CIDDS will be integrated into the current soldier's Load Bearing Vest and the future Modular Body Armor/Load Carrying Equipment.

TRANSPORTATION CHARACTERISTICS / LIMITATIONS: The CIDDS will be capable of being employed and carried by the Individual Soldier. While he may be transported by aircraft, parachute, water craft, and/or wheeled/tracked vehicle, most stress and virtually all usage will occur at the hands of the soldier while afoot.

HISTORICAL BACKGROUND:

Apr 97 MS I/II Decision.
 May 97 Solicitation Released.
 Jul 97 Contract Award.

REQUIREMENTS DOCUMENT: Joint MNS 26 Mar 92, ORD Jun 97.

TYPE CLASSIFICATION: N/A

RELEASEABLE TO SECURITY ASSISTANCE CUSTOMERS: Yes

<u>EVENT SCHEDULE</u>	<u>FISCAL YEAR</u> QTR	97				98				99				00				01				02			
		1	2	3	4	1	2	3	4	1	2	3	4	1	2	3	4	1	2	3	4				
Contract Award					4																				
Preliminary Design Review (PDR)							1																		
Critical Design Review (CDR)							2																		
PQT-C								4																	
PQT-G									1																
IOT									2																
Milestone III											4														

SYNOPSIS: CIDDS IS AN ACTIVE TECHNOLOGY SOLUTION TO ELIMINATE SOLDIER-TO-SOLDIER FRATRICIDE.

PM, JSTARS

PM, JSTARS/JTT

**COMMANDERS TACTICAL TERMINAL (CTT)
JOINT TACTICAL TERMINAL/COMMON
INTEGRATED BROADCAST SERVICE-MODULE
(JTT/CIBS-M)**

PRODUCT MANAGER: LTC S. Kostek,
DSN 987-5059
COMM 732/427-5059
FAX: 732/427-5120
E-Mail: kosteks@doim6.monmouth.army.mil

ACQUISITION CATEGORY: III
ACQUISITION PHASE: Low Rate Initial
Production

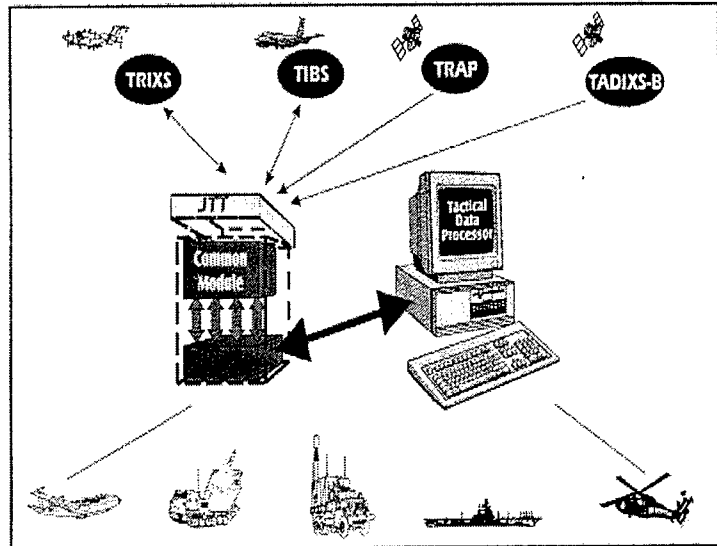

DESCRIPTION: The Joint Tactical Terminals (JTT) and the Commander's Tactical Terminal (CTT) provide the joint war-fighter with near-real-time tactical intelligence and targeting information. The terminals supply the critical data link to battle managers, intelligence centers, air defense, fire support and aviation nodes across all services. The terminals allow Army, Air Force, Navy and Marine Corps users to exploit Integrated Broadcast Service (IBS) networks: Tactical Reconnaissance Intelligence eXchange Service (TRIXS), Tactical Information Broadcast Service (TIBS), Tactical Related Applications (TRAP), and Tactical Data Information eXchange System-B (TADIXS-B). JTT and CTT receive all IBS networks and transmit in TRIXS or TIBS. The CTT and other terminals are migrating to a single JTT family of equipment with insertion of CIBS-M modules.

CTT has 3 terminal configurations: CTT1, CTT2, and CTT3. CTT1 has one full-duplex channel for transmit and receive in TRIXS. CTT2 has two channels for receive in TRIXS, TIBS, TDDS and TADIXS-B. CTT3 has three channels for receive in TRIXS, TIBS, TDDS and TADIXS-B, and 1 channel for transmit in TRIXS and TIBS. JTT has eight channels for receive in TRIXS, TIBS, TDDS and TADIXS-B, and 1 channel for transmit in TRIXS and TIBS. JTT is also Demand Assign Multiple Access (DAMA) capable. The JTT will provide interoperability with future IBS networks. JTT comprises of Common IBS modules (CIBS-M). JTT terminals will be connected to host systems and stand-alone configurations may also be provided. CIBS-M modules may be integrated directly into systems other than JTT terminals on a module-by-module basis.

TRANSPORTATION CHARACTERISTICS / LIMITATIONS: The JTT and CTT are integrated into other weapon systems and are transported with the host system/platform. The equipment will be mounted in fixed and rotary wing aircraft, surface ships, and fixed or mobile ground platforms and vehicles.

HISTORICAL BACKGROUND:

- Jun 83 JSOR approved - Updated Apr 92.
- May 88 Multi Service Test and Evaluation.
- Mar 93 Limited User Test.
- Oct 95 Integrated Broadcast Service Plan Approved.
- Dec 95 CTT3 Production Award.
- Jun 97 CTT3 Production Award (Urgent).
- Aug 97 CTT3 Delivery Begins.
- Sep 97 JTT/CIBS-M competitive LRIP Contract Awarded.

REQUIREMENTS DOCUMENT: ORD for JTT and CIBS-M approved 13 Sep 96.

TYPE CLASSIFICATION: N/A.

RELEASEABLE TO SECURITY ASSISTANCE CUSTOMERS: Yes (Releaseable to UK, Canada, Australia and New Zealand).

EVENT SCHEDULE	FISCAL YEAR															
	97		98		99		00		01		02					
	QTR		QTR		QTR		QTR		QTR		QTR					
	1	2	3	4	1	2	3	4	1	2	3	4	1	2	3	4
CTT 3 Fielding																
JTT/CIBS-M Fielding																

SYNOPSIS: JTT IS A SECURE INTELLIGENCE REPORTING DEVICE.

PM, JSTARS/JTT

**JOINT STARS GROUND STATION MODULE (GSM)
COMMON GROUND STATION (CGS)**

PRODUCT MANAGER: R. Schaefer.
DSN 987-5174
COMM 732/427-5174
FAX: 732/427-5120
Email: sfac-iew-js@doim6.monmouth.army.mil

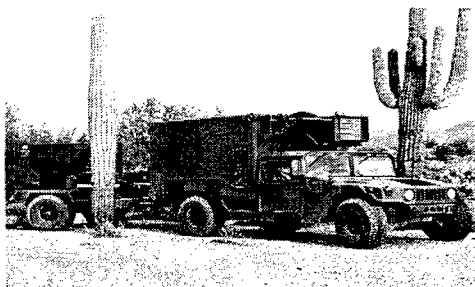

ACQUISITION CATEGORY: ID
ACQUISITION PHASE: MS II LRIP

PE & LINE #: 64770.D202 BA1080



DESCRIPTION: The Joint Surveillance Target Attack Radar System (Joint STARS) Ground Station Module (GSM) is a Mobile Multisensor Imagery Intelligence (IMINT) tactical data processing and evaluation center. The GSM is a subcomponent of a joint Army/Air Force program whose other major component is the E-8 airborne platform. The Joint STARS system is designed to detect, locate and track moving and stationary ground equipment targets located beyond the Forward Line of Troops (FLOT). The GSM processes data from the Joint STARS aircraft Commanders Tactical Terminals (CTT), Joint Tactical Terminal (JTT), and Unmanned Aerial Vehicles (UAV) and disseminates intelligence, battle management and targeting data to Army Command, Control, Communications and Intelligence (C3I) nodes via LAN, wire or radio. This enables integrated battle management, surveillance, targeting and interdiction plans to be developed/executed using near real-time data. Two separate GSM configurations exist. The Medium GSM (MGSM) is housed in a Standard S280 shelter and mounted on a 5-ton truck. A lightweight, rapidly deployable variant, the Light GSM (LGSM) is housed in a Lightweight Multipurpose Shelter (LMS) and mounted on a High Mobility Multipurpose Wheeled Vehicle (HMMWV). The MGSM and LGSM have completed Engineering and Manufacturing Development (EMD), and are currently in Low Rate Initial Production (LRIP). The follow-on GSM, also known as the Common Ground Station (CGS), is the next generation Intelligence and Electronic Warfare (IEW) system. Leveraging off the GSM open architecture the CGS will incorporate secondary Imagery Dissemination (SIDs) and other sensor data providing tactical commanders a comprehensive and common view of the battlefield to aid in battle management, intelligence, and targeting operations. The CGS is also currently in LRIP, with the initial CGS fielding scheduled for FY98. A series of Pre-Planned Product Improvement (P3I) are scheduled to add additional sensor interfaces and data correlation processing capabilities to the CGS.

TRANSPORTATION CHARACTERISTICS / LIMITATIONS: The MGSM is C-17, C-141, and C5 transportable and is sling loadable via CH-47D. The LGSM and CGS are transportable like the MGSM and additionally are drive on C-130 transportable and can be sling loaded by a CH-53E.

HISTORICAL BACKGROUND:

May 82 USDRE directed joint program combining AF's PAVE MOVER and Army's SOTAS programs.
Nov 90 GSMs fielded to Operation Desert Storm.
Sep 93 MGSM LRIP contract awarded.
Jul 95 LGSM LRIP contract awarded.
Dec 95 CGS LRIP contract awarded.
Dec 95 LGSM/MGSMs fielded to Operation Joint Endeavor.

REQUIREMENTS DOCUMENT: ROC approved Apr 86; JSOR approved Nov 92; Revised ROC approved Nov 92.

TYPE CLASSIFICATION: All GSMs currently designated Limited Procurement. TC Standard (Milestone III Scheduled 3Q98).

RELEASEABLE TO SECURITY ASSISTANCE CUSTOMERS: Yes/No

EVENT SCHEDULE	FISCAL YEAR	97		98		99		00		01		02	
		1	2	3	4	1	2	3	4	1	2	3	4
MGSM: Fielding			2										
LGSM: LRIP					3								
Fielding EMD/LRIP			4		3								
CGS: Production													
FUE					3								
Fielding					2								

SYNOPSIS: JOINT STARS GSM AND CGS ARE MOBILE, MULTISENSOR IMINT TACTICAL DATA PROCESSING AND EVALUATION CENTERS.

PM, NV/RSTA

PM, NV/RSTA

AN/AVS-6, AVIATION NIGHT VISION IMAGING SYSTEM (ANVIS)

PROJECT LEADER: Dan Hosek,
DSN 654-3130
COMM 703/704-3130
FAX: 703/704-3449
E-Mail: dhosek@nvl.army.mil

ACQUISITION CATEGORY: III
ACQUISITION PHASE: MS III Production/Deployment

PE & LINE #: SSN: K35601
NSN: 5855-01-138-4749 AN/AVS-6(V)1
AN/AVS-6(V)1A

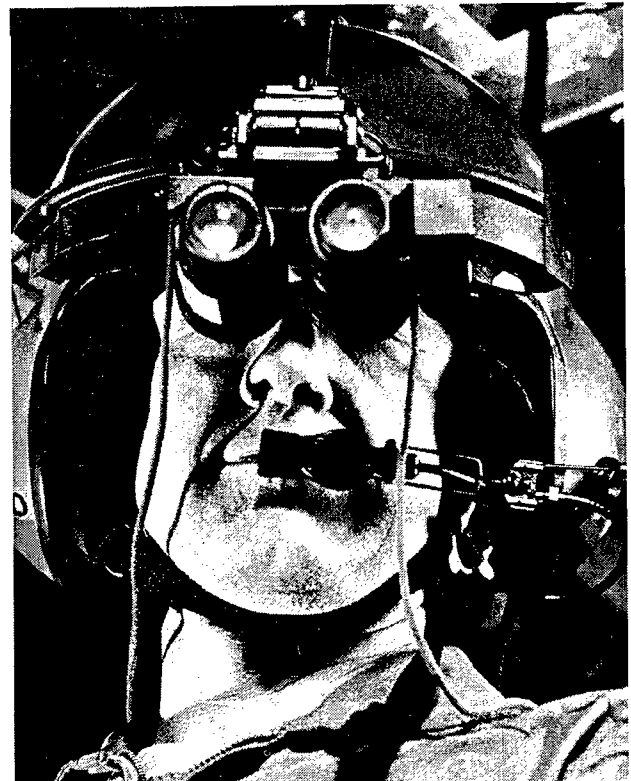

DESCRIPTION: The ANVIS is a lightweight, high performance passive third generation image intensifier system used by helicopter pilots during night flights, including Nap-of-the-Earth (NOE) missions. ANVIS is designed to recognize terrain obstacles at an altitude of 200 feet and below, at a maximum speed of 150 knots, and at light levels down to overcast starlight. The system mounts on an SPH-4 helmet using a mount assembly that replaces the normal visor. When not in use, the binocular assembly can be flipped up and/or easily removed from the helmet if necessary. ANVIS consists of a binocular system with each monocular unit composed of an objective lens assembly, an 18mm (MX-10160 or MX-10160A) third generation image intensifier tube assembly, and an eyepiece assembly. Fielding is two per attack helicopter (AH-1 only), three per utility helicopter, four per cargo helicopter (CH-47) and two per scout helicopter.

TRANSPORTATION CHARACTERISTICS / LIMITATIONS: Shipping/storage case including contents. 15" x 15" x 8",
Weight = 5 lbs. No special transportation requirements.

HISTORICAL BACKGROUND:

3QFY89 Accelerated production authorized, funding increased \$7M in FY90 and FY91.
Feb 90 100% phase-in of improved fiber optics to correct distortion problem.
Mar 90 OMNIBUS II Contracts awarded to ITT (6022 units) and EOS (formerly Varian, 4019 units).
Nov 92 OMNIBUS III Contracts awarded to ITT (600) and Litton (400).
Dec 93 First delivery under OMNIBUS III Contracts.

REQUIREMENTS DOCUMENT: Night Vision System for Army Aircraft - Approved 3 Jan 75.

TYPE CLASSIFICATION: Standard approved Sep 82.

RELEASEABLE TO SECURITY ASSISTANCE CUSTOMERS: Yes, but release limited by 3rd Generation I2 acquisition policy.

<u>EVENT SCHEDULE</u>	FISCAL YEAR	97	98	99	00	01	02
		1 2 3 4	1 2 3 4	1 2 3 4	1 2 3 4	1 2 3 4	1 2 3 4
OMNIBUS IV Deliveries		2-----4					
OMNIBUS V Award (Scheduled)			2				

SYNOPSIS: ANVIS IS A LIGHTWEIGHT, HIGH PERFORMANCE PASSIVE THIRD GENERATION IMAGE INTENSIFIER SYSTEM USED BY HELICOPTER PILOTS DURING NIGHT FLIGHTS.

PM, NV/RSTA

AN/AVS-7, AVIATION NIGHT VISION IMAGING SYSTEM/HEADS UP DISPLAY (ANVIS/HUD)

PROJECT LEADER: Mr. Kevin Mayes,
 DSN 654-3118
 COMM 703/704-3118
 FAX: 703/704-3449
 E-Mail: kmayes@nvl.army.mil

ACQUISITION CATEGORY: III
ACQUISITION PHASE: MS III Production/Deployment

PE & LINE #: SSN: K35601
 NSN: 5855-01-350-0349

DESCRIPTION: The Heads Up Display is a modification to the AN/AVS-6, Aviators Night Vision Imaging System. It will collect and display critical flight information from aircraft sensors and convert this information into visual imagery. This system will allow continuous heads-up flight by the pilot while reducing the pilots need to look inward at the flight instrument panel.

TRANSPORTATION CHARACTERISTICS / LIMITATIONS:
 B-Kit boxed (2 cubic ft), weight 20 lbs. A-Kit boxed (2 cubic ft), weight 20 lbs.

HISTORICAL BACKGROUND:

- Sep 91 NDI Category B, contract award.
- 3Q94 CH-47 FOT&E Testing Completed.
- 3Q94 J&A approved for new aircraft type (CH53).
- 4Q94 Funded Program Year Three Basic and Options.

REQUIREMENTS DOCUMENT: Feb 91 update to Night Vision ROC.

TYPE CLASSIFICATION: Standard for Blackhawk, 1QFY95.

RELEASEABLE TO SECURITY ASSISTANCE CUSTOMERS: Yes



Photo Depicts HUD attached to an AN/AVS-6 Aviators Night Vision Imaging System

<u>EVENT SCHEDULE</u>	<u>FISCAL YEAR</u>											
	97		98		99		00		01		02	
	1	2	3	4	1	2	3	4	1	2	3	4
UH-60 Production/Install												
CH-47 Production/Install												
FUE CH-47	1											
Flight Data Recorder	1			4								
DU EMI Retrofit	1							3				
Advanced ANVIS HUD	1											1
MH-60K A/B kit testing complete					1							
MH-47E A/B kit testing complete					1							
Installation												
Transition												4

SYNOPSIS: ANVIS/HUD IS A MODIFICATION TO THE AVIATORS NIGHT VISION IMAGING SYSTEM AN/AVS-6 WHICH PROVIDES CONTINUOUS HEADS-UP FLIGHT BY THE PILOT.

PM, NV/RSTA

AN/PAS-13, THERMAL WEAPON SIGHT (TWS)

PROJECT LEADER: Mr. Tom Becker,
DSN 654-1255
COMM 703/704-1255
FAX: 703/704-3449
E-Mail: tbecker@nvl.army.mil



ACQUISITION CATEGORY: III
ACQUISITION PHASE: MS II LP

PE & LINE #: 64710.DL70 SSN: K22900

DESCRIPTION: The TWS is a family of low cost, light-weight, manportable infrared imaging devices of medium to high resolution to be used for surveillance fire control of individual and crew served weapons during both daylight and darkness. TWS will operate in adverse weather and battlefield scenarios containing light foliage, smoke, dust and camouflage. TWS will provide early warning, enhance the security of defensive positions, and facilitate offensive operations. TWS replaces AN/PVS-4 and AN/TVS-5 weapon sights. Fielding is five per infantry squad, infantry and other select units.

TRANSPORTATION CHARACTERISTICS / LIMITATIONS: None.

HISTORICAL BACKGROUND:

- 1981 Advanced Development contracts were awarded to Hughes Aircraft Company (HA) and Rockwell International (RI).
- 1983 Night Imaging Thermal Equipment (NITE) Letter of Agreement for TWS.
- 1986 RI terminated.
- 1987 Four Advanced Development units delivered; DT/OT I initiated and completed.
- 1989 Acquisition Plan approved; O&O Plan encompassing TWS and Short Range Thermal Sight (SRTS) capabilities approved; SRTS/TWS thermal technologies successfully demonstrated in Panama under full jungle canopy per SOUTHCOM request.
- 1990 Engineering and Manufacturing Development (EMD) contract awarded to Hughes Aircraft Company.
- 1995 LRIP contract awarded to Hughes Aircraft Company.
- 1997 Bridge contract awarded to Hughes Aircraft company to bridge the one year gap to Thermal Omnibus Full and Open Competition.

REQUIREMENTS DOCUMENT: ORD, 1994. Update, 1997.

TYPE CLASSIFICATION: Low Rate Production (LRP) schedule for 2QFY95 @ LRIP IPR.

RELEASEABLE TO SECURITY ASSISTANCE CUSTOMERS: Yes

<u>EVENT SCHEDULE</u>	<u>FISCAL YEAR</u> QTR	97			98			99			00			01			02			03		
		1	2	3	4	1	2	3	4	1	2	3	4	1	2	3	4	1	2	3	4	
LP Deliveries		1-----			-----3																	
FUE		4																				
MS III					1																	
Production Contract Award (OMNI I)					2																	
Bridge IPT					2--3																	
Bridge Deliveries					3---	-----3																
Production IPT (OMNI I)									3													
Production Deliveries (OMNI I)									3---	-----2												
Production Contract Award (OMNI II)													2									
Production IPT (OMNI II)																	3					
Production Deliveries (OMNI II)																	3---	-----				

SYNOPSIS: TWS IS A FAMILY OF LOW COST, LIGHTWEIGHT, INFRARED IMAGING DEVICES OF MEDIUM TO HIGH RESOLUTION. THEY ARE USED FOR FIRE CONTROL OF INDIVIDUAL AND CREW SERVED WEAPONS DURING BOTH DAYLIGHT AND DARKNESS.

PM, NV/RSTA

AN/PVS-7D, NIGHT VISION GOGGLES

PROJECT LEADER: Dan Hosek,
 DSN 654-3130
 COMM 703/704-3130
 FAX: 703/704-3449
 E-Mail: dhosek@nvl.army.mil

ACQUISITION CATEGORY: III
ACQUISITION PHASE: MS III Production/Deployment

PE & LINE #: SSN: K36400
 NSN: 5855-01-228-0939 (A)
 5855-01-228-0937 (B)
 5855-01-422-5413 (D)



DESCRIPTION: The AN/PVS-7D is a lightweight, high performance passive third generation image intensifier system. The goggle assembly is a headmounted or helmet mounted, self-contained night vision system containing one biocular unit. This biocular consists of an objective lens assembly, an image intensifier tube, a housing assembly, and a biocular eyepiece assembly. The assembly incorporates an infrared (IR) light source which provides illumination to permit close-in-viewing. Fielding is five per infantry squad/battalion and 75 per Infantry company. The AN/PVS-7D is a single tube Image Intensifier system which replaces the earlier AN/PVS-5 binocular second generation image intensifier goggle. All AN/PVS-7D systems are being delivered with third generation tubes (MX-10130D).

TRANSPORTATION CHARACTERISTICS / LIMITATIONS: Weight = 680 g.

HISTORICAL BACKGROUND:

- Dec 85 Five year multi-year production contracts awarded to IIT/Varo Joint Venture (AN/PVS-7B) and Litton (AN/PVS-7A).
- Feb 88 Initial fielding to 7th ID Ft. Hood.
- Feb 89 Life Cycle Cost Study indicated no preference for AN/PVS-7A over the AN/PVS-7B.
- Mar 90 Three-year Production contract awarded to IIT and EOS.
- Nov 92 Five year multi-year production contracts awarded to IIT and Litton.
- Dec 93 First delivery under OMNIBUS III Contracts.
- Sep 96 First delivery under OMNIBUS IV Contract.

REQUIREMENTS DOCUMENT: TRADOC ACN 36829, 21 Jan 82.

TYPE CLASSIFICATION: Standard approved Feb 88.

RELEASEABLE TO SECURITY ASSISTANCE CUSTOMERS: Yes, but release limited by 3rd Generation I² acquisition policy.

<u>EVENT SCHEDULE</u>	<u>FISCAL YEAR</u>											
	97		98		99		00		01		02	
	1	2	3	4	1	2	3	4	1	2	3	4
OMNIBUS III Production								4				
OMNIBUS IV Production									2			
OMNIBUS V Award				2								
OMNIBUS V Production					4					4		

SYNOPSIS: AN/PVS-7D IS A HEADMOUNTED SELF CONTAINED NIGHT VISION GOGGLE FOR CLOSE-UP VIEWING BY THE INDIVIDUAL SOLDIER TO PERFORM TASKS AT NIGHT.

PM, NV/RSTA

AN/PVS-10, SNIPER NIGHT SIGHT (SNS)



PROJECT LEADER: Mr. Jack Lillie,
DSN 654-3059
COMM 703/704-3059
FAX: 703/704-3449
E-Mail: jlillie@nvl.army.mil

ACQUISITION CATEGORY: III
ACQUISITION PHASE: MS III Production/Deployment

PE & LINE: SSN: K41500
NSN: 5855-01-410-8979

DESCRIPTION: The Night Vision Sniperscope is an integrated day/night sight for the M24 Sniper Rifle. The Sniperscope provides the sniper the capability to acquire and engage targets during low and high ambient light conditions. For night operation, the Sniperscope utilizes third generation image intensification technology. For day use, the Sniperscope is a direct view system. It mounts to the existing rail of the M24 and uses the same mil-dot reticle as the existing Leupold day scope. The magnification for day and night operation is 8.5X. The system's maximum weight is 4.90 pounds. It includes a day/night selector switch, and adjustments for output brightness and reticle illumination.

TRANSPORTATION CHARACTERISTICS / LIMITATIONS: Shipping/storage case including contents: 16" x 10" x 6", 7 lbs.
No special transportation requirements.

HISTORICAL BACKGROUND:

FY92 SEP Program Managed by PM Small Arms.
Sep 92 Production Management Transitioned to PM, NV/RSTA.
Aug 93 SNS Requirements Finalized by USAIS.
Nov 93 RFP Issued.
Apr 94 Milestone I/III (TC Generic) IPR Approved.
Apr 94 Contract Award to VARO, Inc. (now Litton).

REQUIREMENTS DOCUMENT: Aug 93 - Changes to M24 SWS Letter Requirement (1986).

TYPE CLASSIFICATION: Generic (Apr 94), Standard (Apr 96).

RELEASEABLE TO SECURITY ASSISTANCE CUSTOMERS: Yes, but release limited by 3rd Generation I² acquisition policy.

<u>EVENT SCHEDULE</u>	FISCAL YEAR	97	98	99	00	01	02
		QTR	1 2 3 4	1 2 3 4	1 2 3 4	1 2 3 4	1 2 3 4
IPT			1				
Deliveries			1----- 4				

SYNOPSIS: THE SNIPER NIGHT SIGHT (SNS) IS AN INTEGRATED DAY/NIGHT SIGHT FOR THE M24 SNIPER RIFLE.

PM, NV/RSTA

AN/PVS-14, MONOCULAR NIGHT VISION DEVICE (MNVD)

PROJECT MANAGER: Dan Hosek,
DSN 654-3130
COMM 703/704-3130
FAX: 654-3449
COMM: 703/704-3449
E-Mail: mccormic@nvl.army.mil

ACQUISITION CATEGORY: III
ACQUISITION PHASE: Production

PE & LINE #: SSN: K36400

DESCRIPTION: The MNVD provides leaders of combat infantry units with a lightweight night vision device. The MNVD is used in observation and command and control missions. It may be used by the soldier in several modes: hand held, head mounted, helmet mounted or affixed and boresighted to a rifle with aiming light. For longer range observation missions, a 3x magnifier is provided. The MNVD uses 3rd Gen I2 technology and is capable down to overcast starlight.



TRANSPORTATION CHARACTERISTICS / LIMITATIONS: None.

HISTORICAL BACKGROUND:

Nov 95 Milestone I/III.

REQUIREMENTS DOCUMENT: ORD, 1993.

TYPE CLASSIFICATION: Standard.

RELEASEABLE TO SECURITY ASSISTANCE CUSTOMERS: Yes, but release limited by 3rd Generation I² acquisition policy.

EVENT SCHEDULE	FISCAL YEAR QTR	97				98				99				00				01				02			
		1	2	3	4	1	2	3	4	1	2	3	4	1	2	3	4	1	2	3	4				
Deliveries		3																			4				
TC Standard		4																							
Material Release						1																			
FUE						1																			
OMNIBUS V Award						2																			
OMNIBUS V Deliveries						4																			4

SYNOPSIS: THE MNVD WILL PROVIDE LEADERS OF COMBAT INFANTRY UNITS WITH A LIGHTWEIGHT NIGHT VISION DEVICE WHICH IS USED IN OBSERVATION AND COMMAND AND CONTROL MISSIONS.

PM, NV/RSTA

AN/PLQ-8 TARGET LOCATION AND OBSERVATION SYSTEM (TLOS)

PROJECT LEADER: Mr. Kevin Hunt,
DSN 654-1151
COMM 703/704-1151
FAX: DSN 654-3449
COMM 703/704-3449
E-Mail: khunt@nvl.army.mil

ACQUISITION CATEGORY: III
ACQUISITION PHASE: Production

PE & LINE #: KA3500 K38400

DESCRIPTION: The TLOS allows the individual soldier to find threat optical and electro-optical surveillance devices located on tanks, scouts, snipers, etc. Location of these potential targets will enhance the effectiveness for U.S. forces. TLOS also has capability to provide covert illumination for fire direction, improved night vision sighting and landing zone marking. Enhanced TLOS will include rangefinding, precise target location, and digital battlefield capability.

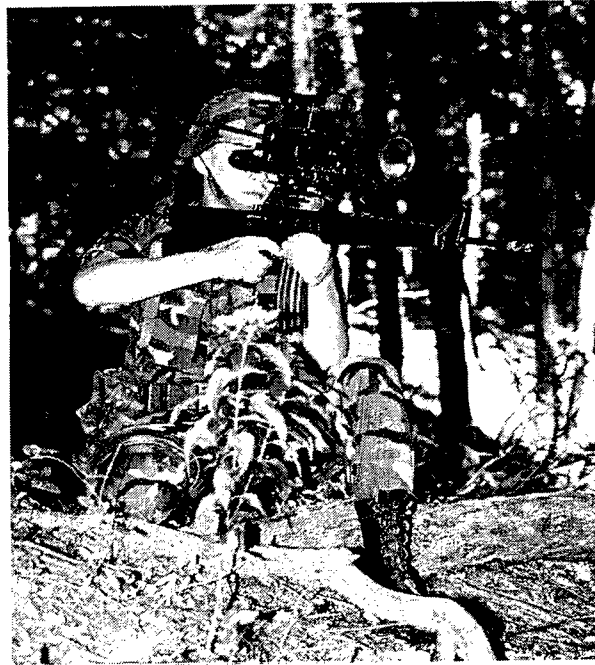

TRANSPORTATION CHARACTERISTICS / LIMITATIONS: Weapon mounted, Manportable.

HISTORICAL BACKGROUND:

- 1991 Program initiated as part of Laser Countermeasures System (LCMS).
- Aug 95 LCMS Production Contract Awarded.
- Dec 95 TLOS program restructured by OSD.
- Mar 96 Contract mod for production of TLOS.

REQUIREMENTS DOCUMENT: Required Operational Capability (ROC) 12 Sep 91.

TYPE CLASSIFICATION: Standard 2QFY98.

RELEASEABLE TO SECURITY ASSISTANCE CUSTOMERS: No

<u>EVENT SCHEDULE</u>	<u>FISCAL YEAR</u>		97	98	99	00	01	02
	<u>QTR</u>		1 2 3 4	1 2 3 4	1 2 3 4	1 2 3 4	1 2 3 4	1 2 3 4
IPT/FAT			2-----	--1				
Follow on DT/OT			4---	--1				
Production Deliveries				2----	4			
FUE				2				
Production Deliveries of ETLOS					3-----			

SYNOPSIS: TLOS IS AN ACTIVE/PASSIVE, DAY/NIGHT SIGHT TO PROVIDE THE SOLDIER CAPABILITY TO LOCATE THREAT OPTICS.

PM, NV/RSTA

AN/VAS-5, DRIVER'S VISION ENHANCER (DVE)

PROJECT LEADER: Mr. Joseph A. Brooks, Jr.
DSN 654-1251
COMM 703/704-1251
FAX: 703/704-3449
E-Mail: brooks@nvl.army.mil

ACQUISITION CATEGORY: III
ACQUISITION PHASE: SIPR Limited Procurement

PE & LINE #: 64710DL70 SSN: K31300
NSN: 5855-01-394-7125 (W)

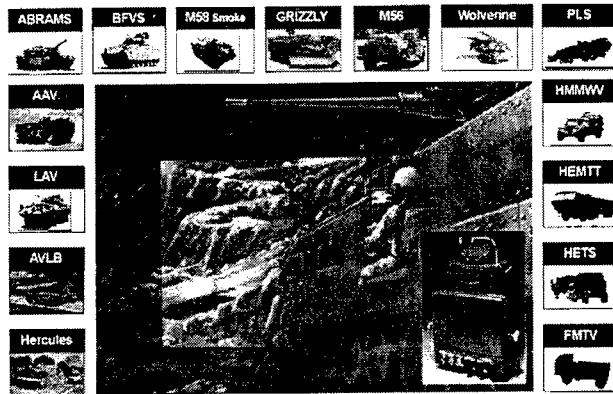

DESCRIPTION: DVE is a passive thermal imaging system which provides drivers of combat and wheeled vehicles GO VS NOGO mobility in all ambient light levels and in the presence of natural and man-made obscurants. Operations must continue in all light levels, weather, and battlefield obscurant conditions (smoke, fog, dust). Thermal driving devices were shown to enhance operational capabilities during Operation Desert Storm and subsequent Advanced Warfighting Experiments.

TRANSPORTATION CHARACTERISTICS / LIMITATIONS: None.

HISTORICAL BACKGROUND:

- Jul 93 Tactical Wheeled Vehicle (TWV) ORD Approval.
- Jul 93 Milestone I/II.
- Aug 93 NDI Contracts Awarded.
- Jan 94 Combat Vehicle Configuration Contract Award.
- Apr 94 USA-USMC MOU Signed.
- Jun-Aug 94 Engineering Models delivered.
- Aug 95 Limited Procurements (LP) Special In-Process Review.
- Aug 95 LP Contract awarded to Texas Instruments.
- Oct 95 Designated Army HTI Program
- Mar 97 LP Bridge awarded to Texas Instruments.
- 3QFY97 FUE.

REQUIREMENTS DOCUMENT: Tactical Wheeled Vehicle (TWV) ORD Approved 18 Jul 93. Vehicle ORDs: M1A2, BFVS, AGS I FLIR ORD. M58 Smoke Vehicle Urgent Operational Requirements TWV-DVE Task Force Eng - Jun 96.

TYPE CLASSIFICATION: LP 4QFY95 (At SIPR) STD 1QFY97 (At MS III).

RELEASEABLE TO SECURITY ASSISTANCE CUSTOMERS: Yes

EVENT SCHEDULE	FISCAL YEAR	97		98		99		00		01		02	
		QTR	1	2	3	4	1	2	3	4	1	2	3
LP Phase					4								
MS III		1											
Full Production			3										

SYNOPSIS: DVE IS A PASSIVE THERMAL IMAGING SYSTEM FOR DRIVERS OF COMBAT AND TACTICAL WHEELED VEHICLES. IT ALLOWS CONTINUED OPERATIONS DAY OR NIGHT AND IN THE PRESENCE OF NATURAL AND MAN-MADE OBSCURANTS (SMOKE, FOG, DUST).

PM, NV/RSTA

**HORIZONTAL TECHNOLOGY INTEGRATION
SECOND GENERATION FLIR (HTI SGF)**

PRODUCT MANAGER: LTC Curtis McCoy,
DSN 654-1192
COMM 703/704-1192
FAX: DSN 654-3192
E-Mail: cmccoy@nvl.army.mil

ACQUISITION CATEGORY: II
ACQUISITION PHASE: MS III LRIP

PE & LINE: 0604710A SSN: K30400

**Horizontal Technology Integration
2nd Generation FLIR
Ground Systems**

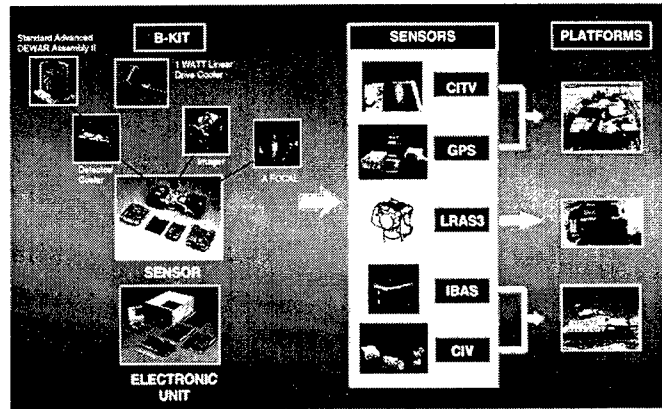

DESCRIPTION: The Horizontal Technology Integration of a Second Gen FLIR (HTI SGF) will enable the Army to insert a common second generation thermal sensor into its highest priority battlefield platforms (the M2A3 Bradley Fighting Vehicle System, the M1A2 Abrams and Long Range Advanced Scout Surveillance System (LRAS3)). The HTI SGF program will concurrently develop an "A" kit, which is specific to each candidate vehicle, and includes the integration and installation, and the "B" kit, which includes the common Forward Looking Infrared (FLIR) sensor.

In the future, this HTI SGF Common FLIR may be used in other ground platforms, or even fixed and rotary wing aircraft.

TRANSPORTATION CHARACTERISTICS / LIMITATIONS: None.

HISTORICAL BACKGROUND:

- 3 Feb 93 Second HTI DA Task Force Established.
- 3 Jul 94 EMD Contract Awarded.
- 7 Jul 94 MSII ASARC Completed.
- 7 Jun 95 CDR completed.
- 20 Dec 96 LRIP Approval.
- 7 Apr 97 LRIP Contracts Awarded.

REQUIREMENTS DOCUMENT: Improved FLIR ORD dtd 9 Dec 93.

TYPE CLASSIFICATION:

RELEASEABLE TO SECURITY ASSISTANCE CUSTOMERS: Yes

EVENT SCHEDULE	FISCAL YEAR		97	98	99	00	01	02
	QTR		1 2 3 4	1 2 3 4	1 2 3 4	1 2 3 4	1 2 3 4	1 2 3 4
DA IPR for "B" Kit LRIP Decision			1					
M/S III Decision				3				
FUE						2		

SYNOPSIS: SECOND GEN FLIR WILL UPGRADE M1A2, M2A3, TO DOUBLE THE ID RANGE AND INCREASE TARGET RECOGNITION RANGES BY 94%.

PM, NV/RSTA

LIGHTWEIGHT LASER DESIGNATOR RANGEFINDER (LLDR)

PROJECT LEADER: William Thodos,
DSN 654-1202
COMM 703/704-1202
FAX: 703/704-3449
E-Mail: bthodos@nvl.army.mil

ACQUISITION CATEGORY: III
ACQUISITION PHASE: Engineering & Manufacturing Development (EMD)

PE & LINE #: 654710.DL70



DESCRIPTION: LLDR is a man-portable, modular target location/target designation system whose major components are a Target Locator Module, a Target Designation Module, and a tripod. The Target Location Module contains an integrated day/night thermal sight, an eyesafe laser rangefinder, azimuth/compass vertical angle measurement, Global Positioning System, and automated digital target data export capability. The Target Designation Module contains a laser which will designate targets at up to 5 kilometers for all DoD/NATO laser guided munitions. The LLDR will weigh less than thirty-five pounds and can be easily transported by a two-man team. Since it is modular, the target location capability can be operated without the Target Designation Module. Boresight verification and operator assurance of accurate target designation will be accomplished through the ability of the target location optics to "see" the laser designation spot. LLDR is a Warfighting Rapid Acquisition Program (WRAP) initiative, and will use WRAP funding to accelerate initial deployment and accomplish vehicle integration efforts.

TRANSPORTATION CHARACTERISTICS / LIMITATIONS: The system is comprised of modules weighing less than 15 pounds which can be transported by a two-man team. The system will also be able to be used in a vehicle-mounted configuration on the BFIST and Laser Strike (HMMWV) vehicles.

HISTORICAL BACKGROUND:

- Jul 92 Market Survey.
- Feb 94 ORD Approval.
- Sep 95 Advanced Demonstrator system contract award.
- Sep 96 Design trade study awards (3).
- Jul 97 EMD Contract award.

REQUIREMENTS DOCUMENT: ORD approved Feb 94. Urgency of Need Statement signed in January 1997.

TYPE CLASSIFICATION:

RELEASEABLE TO SECURITY ASSISTANCE CUSTOMERS: TBD

<u>EVENT SCHEDULE</u>	<u>FISCAL YEAR</u>											
	97		98		99		00		01		02	
	1	2	3	4	1	2	3	4	1	2	3	4
Design trade study complete	1											
EMD Solicitation	2											
EMD Award	3											
Production Award								2				

SYNOPSIS: LLDR IS A MANPORTABLE LASER TARGET DESIGNATOR, RANGEFINDER AND LOCATOR WITH DAY/NIGHT CAPABILITY.

PM, NV/RSTA

Lightweight Video Reconnaissance System

LIGHTWEIGHT VIDEO RECONNAISSANCE SYSTEM (LVRS) AN/PVH - (1 & 2)

PROJECT LEADER: Jaime Gonzalez,
 DSN 654-3466
 COMM 703/704-3466
 FAX: 703/704-3449
 E-Mail: gonzalez@nvl.army.mil

ACQUISITION CATEGORY: III
ACQUISITION PHASE: I/III Production

PE & LINE #: SSN: K30800

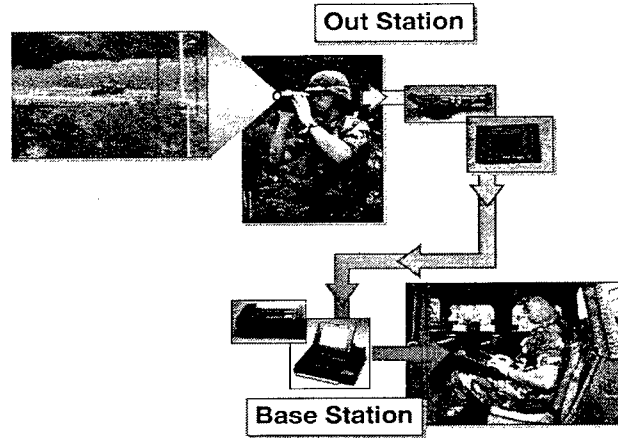

DESCRIPTION: The LVRS consists of a manportable Out Station AN/PVH-1 and a vehicle mounted Base Station AN/PVH-2. The Out Station is used by surveillance or reconnaissance teams to capture, compress and transmit still frame images over SINCGARS military radios to the Base Station located at a higher echelon. Base Stations will have the capability to exchange still frame images with other Base Stations. The Out Station consists of the following components: high resolution video day/night camera incorporating an image intensifier tube for nighttime operations; out station computer used to capture, annotate, and compress images. Image compression is performed using either NITFS 2.0 standard format (JPEG) or a higher performance wavelet algorithm. The protocol is TACO2 with Forward Error Correction (FEC) to assure error free transmission. The Base Station consists of a ruggedized workstation capable of image reception, decompression, image processing, printing, compression, and re-transmission over SINCGARS.

TRANSPORTATION CHARACTERISTICS / LIMITATIONS: Out Station - Transit Case 6" x 24" x 36", 25 lbs. Base Station - Transit Cases (2) 6" x 24" x 36", 25 lbs; 12" x 24" 50lbs.

HISTORICAL BACKGROUND:

- Dec 92 SEP Program began.
- Nov 94 Management transferred to PM-NV/RSTA from PM-Soldier.
- Apr 95 Milestone I/III Decision - TC Generic.
- Sep 95 Contract Award to TI.

REQUIREMENTS DOCUMENT: Simplified ORD dated 23 Dec 92.

TYPE CLASSIFICATION: Standard Approved.

RELEASEABLE TO SECURITY ASSISTANCE CUSTOMERS: No

EVENT SCHEDULE	FISCAL YEAR															
	97		98		99		00		01		02					
	QTR		QTR		QTR		QTR		QTR		QTR					
	1	2	3	4	1	2	3	4	1	2	3	4	1	2	3	4
IPT Retest	1															
Milestone III - TC Standard		4														
FUE					1											

SYNOPSIS: LVRS CONSISTS OF A MANPORTABLE OUT STATION (AN/PVH-1) AND A VEHICLE MOUNTED BASE STATION (AN/PVH-2). THE OUT STATION IS USED BY SURVEILLANCE OR RECONNAISSANCE TEAMS TO CAPTURE, COMPRESS, AND TRANSMIT STILL FRAME IMAGES OVER MILITARY RADIOS TO THE BASE STATION LOCATED AT A HIGHER ECHELON.

PM, FLIR

**LONG RANGE ADVANCED SCOUT
SURVEILLANCE SYSTEM (LRAS3)**

PROJECT LEADER: Darryl Phillips,
DSN 654-3049
Assistant Product Manager: Major Mark A. Conley,
DSN 654-1941
COMM 703/704-3049/1941
FAX: 703/704-1461
E-Mail: dphillip@nvl.army.mil or mconley@nvl.army.mil

ACQUISITION CATEGORY: III
ACQUISITION PHASE: MS II Engineering and
Manufacturing Development

PE & LINE #: TBD SSN: TBD NSN: TBD

DESCRIPTION: The LRAS3 will provide the scout with a long-range reconnaissance and surveillance sensor system to operate in both mounted and manportable configurations. The LRAS3 will provide real-time acquisition, target detection, recognition, and location information to the cavalry scout while permitting 24 hour target acquisition capabilities. It provides long-range target detection and far target location at standoff ranges which are beyond the effective range of enemy direct fire weapons. The LRAS3 will provide imagery for the scout to quickly detect, recognize, and report targets of military interest.



TRANSPORTATION CHARACTERISTICS / LIMITATIONS: The total system weight excluding the tripod, battery pack, and auxillary equipment weight shall weigh no more than 120 pounds.

HISTORICAL BACKGROUND:

Jul 97 MS I/II Approved.

REQUIREMENTS DOCUMENT: Approved 2 Jun 94.

TYPE CLASSIFICATION: Standard 1Q01

RELEASEABLE TO SECURITY ASSISTANCE CUSTOMERS: No

<u>EVENT SCHEDULE</u>	<u>FISCAL YEAR</u>															
	97		98		99		00		01		02					
	1	2	3	4	1	2	3	4	1	2	3	4	1	2	3	4
Contractor Development Testing					4											
IOT&E									3							
MS III/TC									1							
Production Contract Award									1							
FUE											3					

SYNOPSIS: THE LRAS3 IS A MOUNTED/ MANPORTABLE LONG-RANGE SURVEILLANCE DEVICE. THE LRAS3 IS INTENDED FOR USE IN THE RECONNAISSANCE OF TERRAIN AND SURVEILLANCE OF TARGETS OF TACTICAL INTEREST.

PM, NV/RSTA

SAR TARGET RECOGNITION AND LOCATION SYSTEM (STARLOS)

PRODUCT MANAGER: Robert F. Golden,
DSN 987-5816
COMM 732/427-5816
E-Mail: golden@doim6.monmouth.army.mil

ACQUISITION CATEGORY:
ACQUISITION PHASE: MS I Demo/Validation

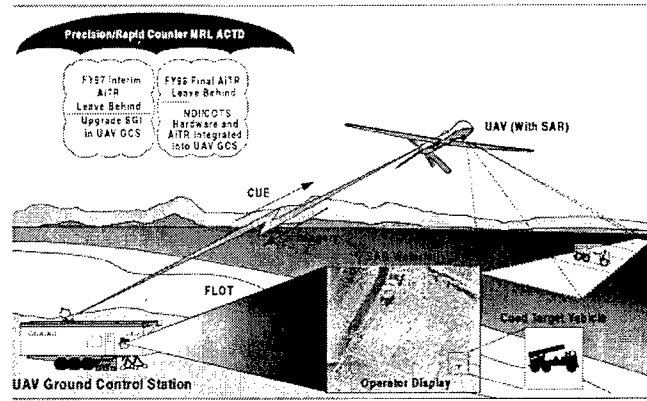

PE & LINE: 0603012.DC24, 0603238.D182/D546

DESCRIPTION: The STARLOS advanced technology demonstration program seeks to locate and identify high value targets from an aerial platform such as an Unmanned Aerial Vehicle (UAV). The targets are located with a Synthetic Aperture Radar (SAR) and identified with an Aided Target Recognition (ATR) system. In all, this system provides precise, timely targeting information on high value targets. STARLOS is also a major component in the Joint Precision Strike/Rapid Counter MRL ACTD.

TRANSPORTATION CHARACTERISTICS / LIMITATIONS: None.

HISTORICAL BACKGROUND: STARLOS was a Special Access Program that has been shifted into the secret collateral world. It is an Advanced Technology Demonstration (ATD) program managed by PM TESAR. The program has become a major component of the Joint Precision Strike Demonstration (JPSD) program for the Precision/Rapid Counter Multiple Rocket Launcher ACTD. The program delivers an interim AiTR solution in FY97 and a final AiTR solution in FY98 for the installation into the MAE UAV Ground Control Station as one of the JPSD CMRL ACTD leave behinds.

REQUIREMENTS DOCUMENT: Airborne Automatic Target Recognition System, approved USAIS, 12 Nov 93.

TYPE CLASSIFICATION:

RELEASEABLE TO SECURITY ASSISTANCE CUSTOMERS: No

EVENT SCHEDULE	FISCAL YEAR		97	98	99	00	01	02
	QTR		1 2 3 4	1 2 3 4	1 2 3 4	1 2 3 4	1 2 3 4	1 2 3 4
Award Contracts for Final AiTR Leave Behind			3					
JPSD's FY97 Interim AiTR Leave Behind Demonstration			4					
MSTB data collection				1				
JPSD's FY98 Final AiTR Leave Behind Demonstration				4				
Final technical/logistic support for Leave Behind					3			

SYNOPSIS: STARLOS WILL PROVIDE REAL-TIME SAR AiTR CAPABILITIES. THESE CAPABILITIES WILL ASSIST/ENHANCE COLLECTION MANAGERS' EFFECTIVENESS AND WILL ALLOW TIMELY AND ACCURATE ENGAGEMENT OF HIGH PAYOFF/VALUE TARGETS.

PM, NV/RSTA

TACTICAL ENHANCED SYNTHETIC APERTURE RADAR (TESAR)

PRODUCT MANAGER: Robert F. Golden
 DSN 987-5816
 COMM 732/427-5816
 E-Mail: golden@doim6.monmouth.army.mil

ACQUISITION CATEGORY: III
ACQUISITION PHASE: MS II PRV

PE & LINE:

DESCRIPTION: TESAR is a synthetic aperture radar (SAR) with .3 meter resolution. It operates under most weather conditions to produce clear, near real time continuous strip map imagery. TESAR serves as a payload for the Medium Altitude Endurance (MAE) Unmanned Aerial Vehicle (UAV) Advanced Concept Technology Demonstration (ACTD). Under the ACTD, ten SAR units will be produced and integrated into the Predator UAV. Three ground control station units are included as adjuncts to the Predator ground control station. SAR components include; processor assembly, antenna, and a receiver/transmitter assembly. The SAR system is now entering its Production Rate Verification (PRV) phase.

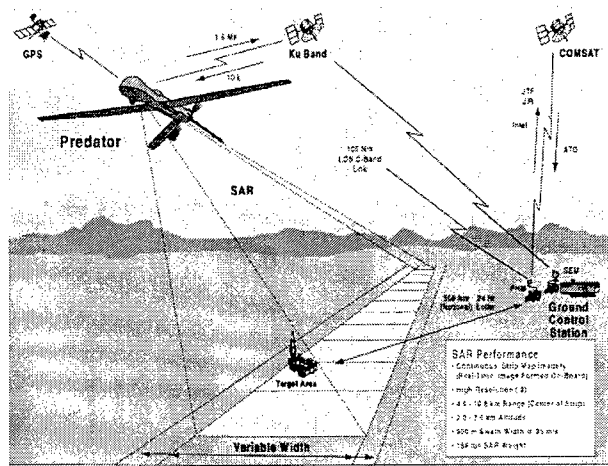

TRANSPORTATION CHARACTERISTICS / LIMITATIONS: None.

HISTORICAL BACKGROUND:

- 30 Nov 93 DA and PEO Cruise Missiles designated PM-TESAR with the management of the development and integration responsibility of the synthetic aperture radar sensor into a medium altitude endurance (MAE) unmanned aerial vehicle (UAV).
- 9 Mar 94 Contract Awarded.
- 9 Aug 94 Accomplished PDR & CDR within 5 months of award.
- 31 Jan 95 Initiated build of 1st unit SAR and GCS.
- Mar 96 Predator system deployed to Operation Joint Endeavor.
- May 97 Contract modification awarded for 9 SAR, 1 GCS and spares.

REQUIREMENTS DOCUMENT: Statement of Urgency signed by the Under Secretary of Defense for Research and Development, John M. Deutch, 12 Jul 93.

TYPE CLASSIFICATION:

RELEASEABLE TO SECURITY ASSISTANCE CUSTOMERS: No

EVENT SCHEDULE	FISCAL YEAR		97		98		99		00		01		02	
	QTR		1	2	3	4	1	2	3	4	1	2	3	4
Decision to proceed to PRV			2											
Awarded contract mod for 9 SAR			3											
Demonstrate MTI, Spotlight, variable swath capabilities			4											
Award contract for FY97 PRV			4											

SYNOPSIS: THE PROGRAM IS DESIGNED TO QUICKLY SATISFY THE MILITARY NEED OF LONG DWELL COVERAGE AND RECONNAISSANCE OF SMALL MOBILE OR FIXED TARGETS. IT WILL ALSO DEVELOP CONCEPTS OF OPERATION FOR ENDURANCE UAV'S.

PM, SENTINEL

PRODUCT MANAGER, SENTINEL

SENTINEL

PRODUCT MANAGER: LTC Tim R. McKaig,
 DSN 788-1673
 COMM 205/722-1673
 FAX: DSN 788-1675
 E-Mail: mckaigt@iew.redstone.army.mil

ACQUISITION CATEGORY: IC
ACQUISITION PHASE: MS III Production & Deployment

PE & LINE #: 64820.DE10 SSN: WK5053
 NSN: 1430-01-369-9984

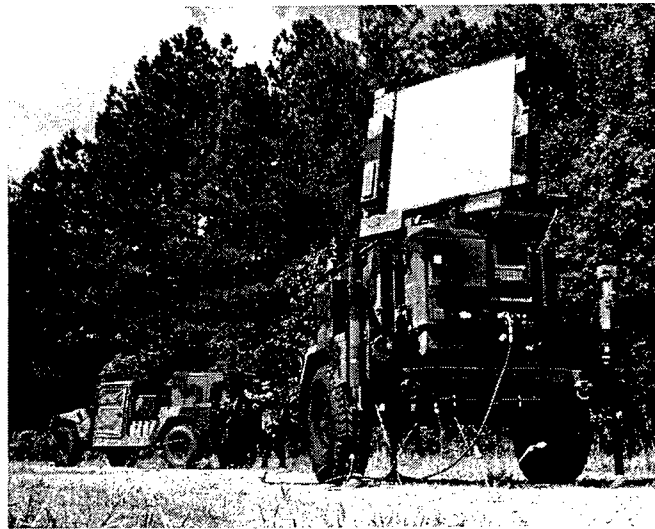

DESCRIPTION: The Sentinel system is the key air surveillance and target acquisition/tracking sensor for short-range air defense (SHORAD) weapons in the division and corps sectors. The system consists of a state-of-the-art three-dimensional battlefield radar which uses modern phased-array antenna technology, a prime mover with a tactical quiet generator and radios, identification friend or foe (IFF) and interfaces to the forward area air defense (FAAD) command and control (C2) network. The Sentinel is accurate, quick-reacting and acquires targets sufficiently beyond the forward line of own troops (FLOT) to reduce SHORAD weapon reaction time and allow engagement at optimum ranges. The radar's integrated IFF helps prevent fratricide and electronic countermeasures-resistant performance supports Army air defense across the full spectrum of conflict.

TRANSPORTATION CHARACTERISTICS / LIMITATIONS: Transported by rail, C-130, UH-60. Length: 26 ft., Width: 8.4 ft., Weight: 12,845 lbs.

HISTORICAL BACKGROUND:

- 1986 JRMB approved Milestone Decision Review II/IIIA.
- Feb 92 Pre Production contract award.
- Jul 94 Long Lead Item Contract Award.
- Jan 95 LRIP contract award.
- Apr 95 Milestone III ADM signed.
- Jun 97 First Unit Equipped.

REQUIREMENTS DOCUMENT: FAAD GBS ORD, 26 Jun 95.

TYPE CLASSIFICATION: Standard, 24 Apr 95.

RELEASEABLE TO SECURITY ASSISTANCE CUSTOMERS: Yes

<u>EVENT SCHEDULE</u>	<u>FISCAL YEAR</u>													
	97		98		99		00		01		02		03	
	QTR		QTR		QTR		QTR		QTR		QTR		QTR	
Task Force XXI	---	2												
LRIP Production	---	3												
Full Rate Production														3
FUE Production Units		3												
Production Verification Test	1	---	4											
P3I							1	---						

SYNOPSIS: SENTINEL IS AN NDI SYSTEM CAPABLE OF PROVIDING SEARCH AND TRACK FUNCTIONS AGAINST FIXED AND ROTARY WING AIRCRAFT.

PM, SW

PM, SW

ADVANCED QUICKFIX (AQF)

PRODUCT MANAGER: LTC Darrell Davis,
DSN 987-1479
COMM 732/427-1479
FAX: 732/427-5822
E-Mail: davis@doim6.monmouth.army.mil



ACQUISITION CATEGORY: III
ACQUISITION PHASE: II - Eng/Manufacturing Dev

PE & LINE #: 0604270/DL12, AB3000

DESCRIPTION: Advanced QUICKFIX (AQF) provides Division and ACR commanders with an organic capability to listen to, locate for hard-kill targeting or order-of-battle resolution, or render ineffective through jamming opposition command and control and fire control nets and identify and locate counter/mortar, counter/battery, ground surveillance and other radar emissions. Configured in a BLACKHAWK Helicopter, it provides the line of sight (LOS) extension necessary to provide for location accuracies sufficient for "Steel on Target" requirements, as well as for extension of C2 Jamming LOS.

TRANSPORTATION CHARACTERISTICS / LIMITATIONS: Self Transportable.

HISTORICAL BACKGROUND:

- Sep 91 AQF integration contract awarded.
- Nov 92 Conducted Critical Design Review (CDR).
- Sep 95 Customer test.
- Nov 95 Contract award of LRIP production (3 systems).

REQUIREMENTS DOCUMENT: AQF ORD, Oct 92.

TYPE CLASSIFICATION: Low Rate Initial Production, Nov 95.

RELEASEABLE TO SECURITY ASSISTANCE CUSTOMERS: No

<u>EVENT SCHEDULE</u>	<u>FISCAL YEAR</u>															
	97		98		99		00		01		02		03			
	<u>QTR</u>															
	1	2	3	4	1	2	3	4	1	2	3	4	1	2	3	4
IOT&E								X								
MS III								X								
Award Full Scale Production Contract									X							

SYNOPSIS: AQF IS A HELIBORNE ELECTRONIC ATTACK, SIGNALS INTELLIGENCE, AND EMITTER TARGETING SYSTEM.

PM, SW

AIRBORNE RECONNAISSANCE LOW (ARL)

PRODUCT MANAGER: LTC Bruce Jette,
DSN 987-5211
COMM 732/427-5211
FAX: 732/427-5822
E-Mail: jette@doim6.monmouth.army.mil

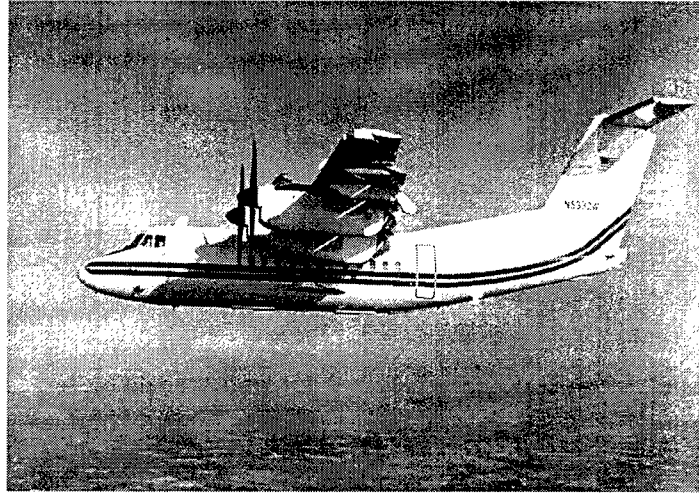

ACQUISITION CATEGORY: III
ACQUISITION PHASE: III - Production/Deployment

PE & LINE #: 35150. A11500

DESCRIPTION: ARL is a multifunction, day/night, all weather reconnaissance intelligence asset developed and fielded by the Army in support of an urgent requirement for a low profile intelligence aircraft. ARL is a modified DHC-7 fixed wing aircraft with a core SIGINT and IMINT mission payload controlled and operated via onboard open architecture, multifunction workstations. The SIGINT subsystem has a HF/VHF/UHF intercept and direction finding (DF) capable Electronic Support Measures (ESM) system. The IMINT subsystem is equipped with infrared line scanner (IRLS), forward looking infrared (FLIR), daylight imaging system (DIS) and a multimode cueing radar and Synthetic Aperture Radar (SAR). The ARL system has been developed to accommodate diverse mission requirements through the implementation of an open architecture, modular, reconfigurable mission sensors. The core complement of sensors may be augmented with low-light level TV (LLTV), MTI, multi-spectral camera, acoustic range extension system, precision targeting subsystem, and remote configuration using a direct air-to-satellite datalink.

Three interim capable ARL systems were fielded to the 204th MIBN(LI), Howard AFB, Panama to support SOUTHCOM requirements. These fielded systems are in two different configurations; two for performing signals intelligence (SIGINT) missions (ARL-C) and one for performing imagery intelligence (IMINT) missions (ARL-I). Three ARL-M, multiple mission (IMINT and SIGINT) capable systems, with the addition of an MTI/SAR have been fielded to Korea to perform the I and W mission of the retiring Mohawk (OV-ID). Two additional ARL-M are currently scheduled to be completed in FY99. All interim capable systems will then be converted to the multiple mission capable ARL-M configuration.

TRANSPORTATION CHARACTERISTICS / LIMITATIONS: Self Transportable/Self Sustainable.

HISTORICAL BACKGROUND:

- May 90 JCS validated Grisly Hunter and ARDF Requirements.
- Nov 90 Congress mandated combining of Grisly Hunter and ARDF into a single program called Airborne Reconnaissance Low.
- Apr 91 ARL-C and ARL-I Contracts Awarded.
- Apr 93 Delivery of first ARL production system.
- Jul 93 MSIII Decision for Production of 9 ARL-M.
- Sep 93 Multifunction option exercised.
- Jun 94 Successful CDR/IPR.
- Jun 95 MDS designation RD-7B approved.
- Nov 95 MTI/SAR program start.
- Jan 96 MTI/SAR CDR.
- Sep 96 Delivery fielding of first 2 ARL-M systems.
- Oct 97 Delivery fielding of third ARL-M system.

REQUIREMENTS DOCUMENT: Grisly Hunter Revised SON approved Mar 90. ARDF SON approved Apr 90. USARPAC SON dated Apr 94.

TYPE CLASSIFICATION: LPU approved May 90; TC Standard expected Jun 96.

RELEASEABLE TO SECURITY ASSISTANCE CUSTOMERS: No

<u>EVENT SCHEDULE</u>	<u>FISCAL YEAR</u>		97	98	99	00	01	02
	<u>QTR</u>		1 2 3 4	1 2 3 4	1 2 3 4	1 2 3 4	1 2 3 4	1 2 3 4
System 7.8 FOC			1-----	-----	---X			

SYNOPSIS: ARL IS A MULTIFUNCTION, DAY/NIGHT, ALL WEATHER RECONNAISSANCE INTELLIGENCE ASSET DEVELOPED AND FIELDIED BY THE ARMY IN SUPPORT OF AN URGENT REQUIREMENT FOR A LOW PROFILE INTELLIGENCE AIRCRAFT.

PM, SW

**AN/MLQ-38, GROUND BASED COMMON
SENSOR HEAVY (GBCS-H)**

PRODUCT MANAGER: LTC Darrell R. Davis,
DSN 987-1479
COMM 732/427-1479
FAX 732/427-5822
E-Mail davisd@doim6.monmouth.army.mil

ACQUISITION CATEGORY: III
ACQUISITION PHASE: II - Eng/Manufacturing Dev

PE & LINE #: 0604270/DL12 and 0305885, BZ7326

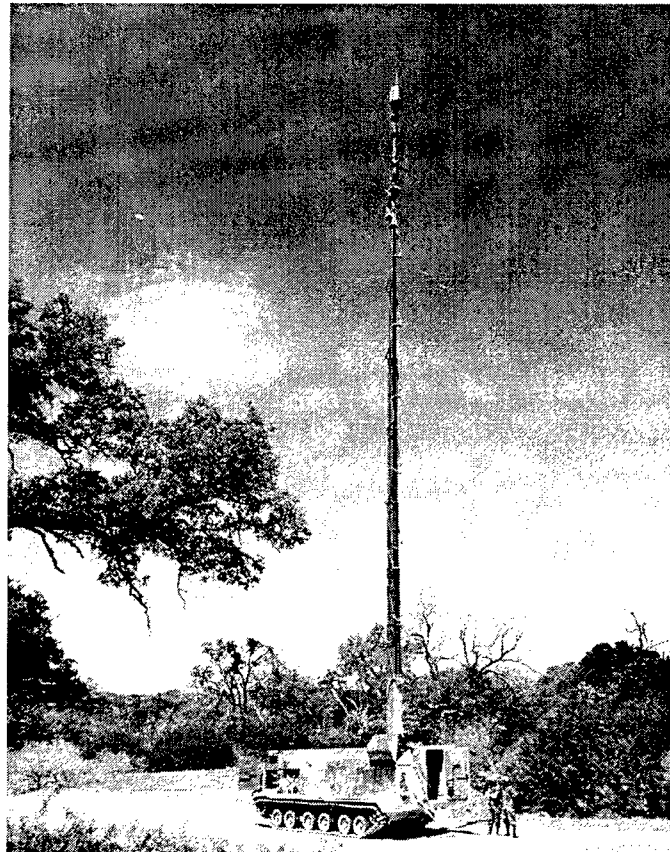

DESCRIPTION: GBCS-H provides commanders of Armored and Mechanized Infantry Divisions with an organic capability to listen to, locate for hard-kill targeting or order-of-battle resolution, or render ineffective through jamming opposition command and control and fire control nets and identify and locate counter/mortar, counter/battery and ground surveillance radar emissions. The system is specifically designed to ensure transportability, prime mover maintainability, and over terrain mobility equal to or greater than supported units, while at the same time exploiting or eliminating - at the supported Commander's discretion - the latest, most modern types of hostile modulations and transmission techniques at the key time and place on the battlefield. GBCS-H is the Army's only on-the-move, on-the-ground, all weather, all terrain, self-contained, fully integrated, 24-hour-a-day signals intelligence and electronic warfare asset.

TRANSPORTATION CHARACTERISTICS / LIMITATIONS: Transportable up to 40,000 feet above sea level and by rail, highway, and water means with system degradation. Roll-on, roll-off capability for C-5.

HISTORICAL BACKGROUND:

- Sep 91 GBCS-H integration contract awarded.
- Nov 92 Conducted Critical Design Review (CDR).
- Sep 95 Participated in AQF Customer Test.
- Jun 96 R&D models fielded to Task Force XXI.

REQUIREMENTS DOCUMENT: IEW GBCS ROC, Oct 90.

TYPE CLASSIFICATION: Standard, Sep 98.

RELEASEABLE TO SECURITY ASSISTANCE CUSTOMERS: No

EVENT SCHEDULE	FISCAL YEAR																							
	97				98				99				00				01				02			
	1	2	3	4	1	2	3	4	1	2	3	4	1	2	3	4	1	2	3	4	1	2	3	4
IOT&E											X													
Milestone III											X													
Award Production Contract													X											

SYNOPSIS: GBCS-H IS A HIGHLY SURVIVABLE, HIGH CAPACITY, ELECTRONIC ATTACK, SIGNALS INTELLIGENCE AND EMITTER TARGETING SYSTEM.

PM, SW

**AN/MLQ-39, GROUND BASED COMMON
SENSOR LIGHT (GBCS-L)**

PRODUCT MGR: LTC Darrell R. Davis,
DSN 987-1479
COMM 732/427-1479
FAX 732/427-5822
E-Mail davisd@doim6.monmouth.army.mil

ACQUISITION CATEGORY: III
ACQUISITION PHASE: II - Eng/Manufacturing Dev

PE & LINE #: 0604270/DL12 and 0305885, BZ7326

DESCRIPTION: GBCS-L provides Commanders of Light, Airborne, and Air Assault Divisions with an organic capability to listen to, locate for hard-kill targeting or order-of-battle resolution, or render ineffective through jamming opposition command and control and fire control nets and identify and locate counter/mortar, counter/battery and ground surveillance radar emissions. The system is specifically designed to ensure transportability, prime mover maintainability, and over terrain mobility equal to or greater than supported units, while at the same time exploiting or eliminating - at the supported Commander's discretion - the latest, most modern types of hostile modulations and transmission techniques at the key time and place on the battlefield.



TRANSPORTATION CHARACTERISTICS / LIMITATIONS: Transportable up to 40,000 feet above sea level and by rail, highway, and water means with system degradation. Must have roll-on, roll-off capability for C-130. Must be transportable by sling-loading by CH-47 or large helicopters.

HISTORICAL BACKGROUND:

- Sep 91 GBCS-L integration contract awarded.
- Nov 92 Conducted Critical Design Review (CDR).
- Jul 94 Customer Test.
- Sep 95 Participated in AQF Customer Test.
- Jun 96 R&D models fielded to Task Force XXI.

REQUIREMENTS DOCUMENT: IEW GBCS ROC, Oct 90.

TYPE CLASSIFICATION: GBCS-L Operational Needs Statement System LPU approved Oct 90. GBCS-L Standard, Sep 96.

RELEASEABLE TO SECURITY ASSISTANCE CUSTOMERS: No

EVENT SCHEDULE	FISCAL YEAR		97		98		99		00		01		02	
	QTR		1	2	3	4	1	2	3	4	1	2	3	4
Award 3rd Year LP			X											
IOT&E						X								
Milestone III						X								
Fielding							X							

SYNOPSIS: GBCS-L IS A RAPID DEPLOYABLE ELECTRONIC ATTACK, SIGNALS INTELLIGENCE, AND EMITTER TARGETING SYSTEM.

PM, SW

**AN/USD-9C, GUARDRAIL/COMMON SENSOR
(GR/CS)**

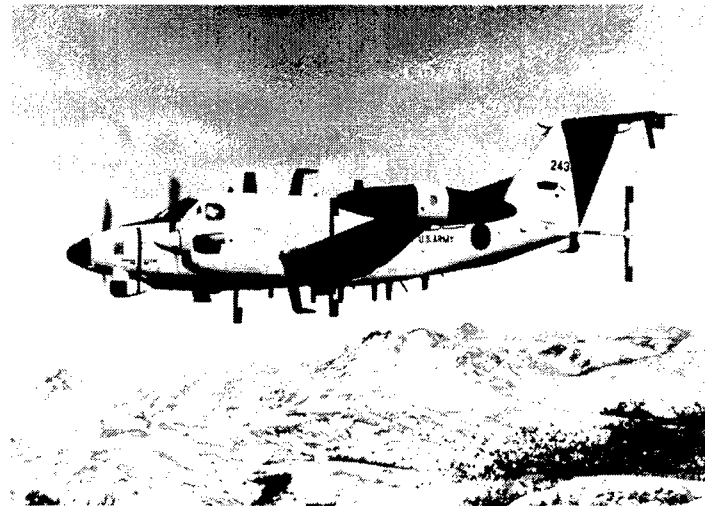

PRODUCT MANAGER: LTC Bruce Jette,
DSN 987-5211
COMM 732/427-5211
FAX: 732/427-5822
E-Mail: jette@doim6.monmouth.army.mil

ACQUISITION CATEGORY: II
ACQUISITION PHASE: III/IV - Prod/Deploy/Ops/Spt

PE & LINE #: A02005 & AZ2000

DESCRIPTION: The GR/CS is a Corps Level Airborne Signal Intelligence (SIGINT) collection/location system. GR/CS integrates the Improved GUARDRAIL V (IGR V), Communication High Accuracy Airborne Location System (CHAALS), and the Advanced QUICKLOOK (AQL) into the same SIGINT platform. One GR/CS system is authorized per Aerial Exploitation Battalion (AEB) in the MI Brigade at each Corps. Each system consists nominally of twelve aircraft which normally fly operational missions in sets of three. GR/CS provides near real-time SIGINT and targeting information to Tactical Commanders throughout the corps area with emphasis on Deep Battle and Follow-on Forces Attack support. The airborne elements are integrated into the RC-12K/N/P/Q aircraft. Ground processing is conducted in the Integrated Processing Facility (IPF). Interoperable Data Links (IDL) provide microwave connectivity between the airborne elements and the IPF. Reporting is accomplished via Commander's Tactical Terminals (CTT). Key features include integrated COMINT and ELINT reporting, enhanced signal classification and recognition, fast Direction Finding (DF), precision emitter location, and an advanced integrated aircraft cockpit. Preplanned product improvements include frequency extension, computer assisted on-line sensor management, upgraded data links and the capability to exploit a wider range of signals.

TRANSPORTATION CHARACTERISTICS / LIMITATIONS: The system can be transported by air, land, or ship.

HISTORICAL BACKGROUND:

Jun 84 Contract awarded for GR/CS Systems 3 and 4.
Dec 88 GR/CS (minus) System 3 fielded to Korea.
Jun 89 AC-12K Production award (System 1).
Aug/Sept 90 GR/CS Systems 1 and 2 IPF and ARF Production contracts awarded.
Aug 91 GR/CS System 4 fielded to USAREUR.
Apr 94 GR/CS FY94-99 Program and Acquisition Plan approved by HQDA.
Aug 94 GR/CS System 1 Fielded to FORSCOM.
Aug 94 GRE Contract Award.

REQUIREMENTS DOCUMENT: ROC, 1 Oct 84, updated Nov 85 and revised in Apr 92.

TYPE CLASSIFICATION: GR/CS System #1 type classified LP.

RELEASEABLE TO SECURITY ASSISTANCE CUSTOMERS: No

EVENT SCHEDULE	FISCAL YEAR	97	98	99	00	01	02
		1 2 3 4	1 2 3 4	1 2 3 4	1 2 3 4	1 2 3 4	1 2 3 4
System 2 Fielding	QTR			X			

SYNOPSIS: GR/CS IS A CORPS LEVEL AIRBORNE SIGINT COLLECTION/LOCATION SYSTEM.

PM, SW

COMMON MODULAR ELINT SYSTEM (CMES)

PRODUCT MANAGER: LTC Darrell R. Davis,
DSN 987-1479
COMM 732/427-1479
FAX: 732/427-5822
E-Mail: davisd@doim6.monmouth.army.mil

ACQUISITION CATEGORY: III
ACQUISITION PHASE: II - Eng/Manufacturing Dev

PE & LINE: 0604270/DL12. 0305885, BZ7326, AB3000.

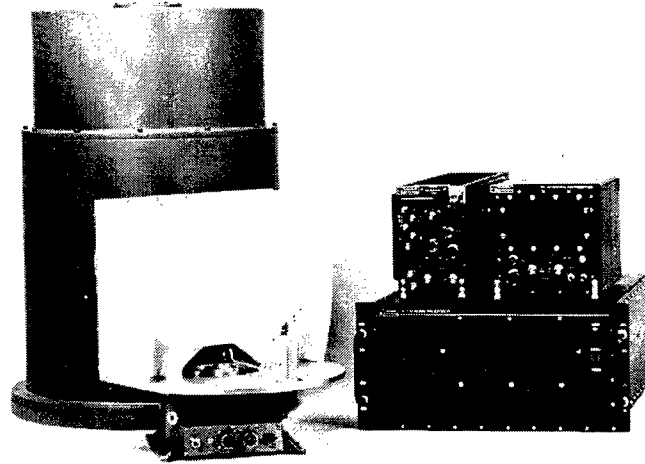

DESCRIPTION: The CMES ELINT Electronic Support Measures (ESM) sensor provides search, intercept, DF, precision location and analysis of the primary noncommunication (radar) battlefield threat emitters. It enhances the Division Commander's ability to out maneuver and kill the enemy by locating High Value Targets (HVTs) such as radars at critical points in the battle. It provides precise emitter locations with targeting accuracy.

TRANSPORTATION CHARACTERISTICS / LIMITATIONS: Not Applicable. This is a subsystem to be transported in accordance with the transportation of the system in which they reside.

HISTORICAL BACKGROUND: CMES is composed of NDI modules that are used on other DOD platforms.

REQUIREMENTS DOCUMENT: IEW GBCS ROC dated 18 Oct 90.

TYPE CLASSIFICATION: Standard, Sep 96.

RELEASEABLE TO SECURITY ASSISTANCE CUSTOMERS: No

<u>EVENT SCHEDULE</u>	FISCAL YEAR QTR	97	98	99	00	01	02
		1 2 3 4	1 2 3 4	1 2 3 4	1 2 3	1 2 3 4	1 2 3 4
LPULRP		-----X					
Full Scale Production		X-----					

SYNOPSIS: CMES IS AN ELINT ESM SENSOR SUBSYSTEM.

PM, SW

**COMMUNICATIONS HIGH ACCURACY
LOCATION SUBSYSTEM EXPLOITABLE
(CHALS-X)**

PRODUCT MANAGER: LTC Darrell Davis,
DSN 987-1479
COMM 732/427-1479
FAX: 732/427-5822
E-Mail: davidd@doim6.monmouth.army.mil

ACQUISITION CATEGORY: III
ACQUISITION PHASE: II - Eng/Manufacturing Dev

PE & LINE: 0604270/DL12, 0305885.
BZ7326, AZ2000, AB3000.

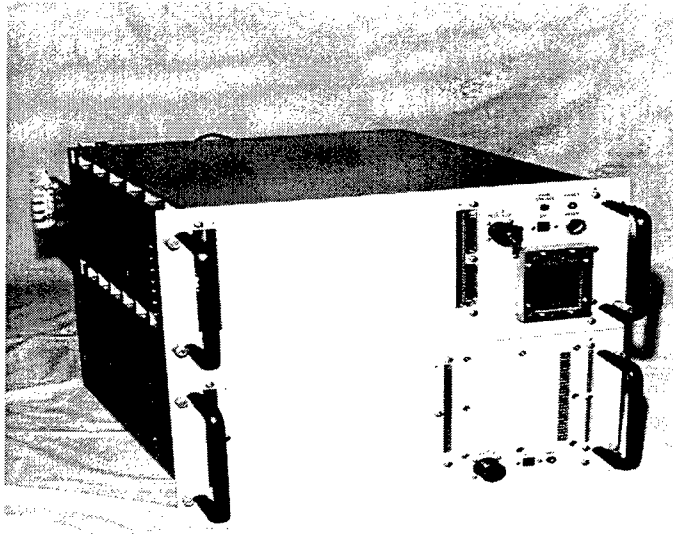

DESCRIPTION: The CHALS-X and X(M) systems provide the targeting capability required to support the Division Commander's requirement to locate and kill the enemy by providing for precise location of High Value Targets (HVTs). Airborne systems mixed with ground based systems will be capable of precisely locating enemy weapon systems and units (regardless of whether the enemy uses conventional or modern radios) producing target locations sufficiently accurate for first round fire for effect by organic artillery. CHALS-X and X(M) is a continuation of the project which developed the precision location subsystem (CHAALS) currently in GUARDRAIL Common Sensor (GR/CS) systems 1, 3 and 4. It utilizes Time-Difference-Of-Arrival/Differential Doppler (TDOA/DD) techniques and incorporates advances in electronics state of the art and distributed processing; increases frequency range, adds LPI radios to the target set, and decreases size/weight/power requirements of processing subsystems (3 racks of computer equipment now reduced to one box which fits into a standard ATR rack).

TRANSPORTATION CHARACTERISTICS / LIMITATIONS: Not Applicable. This is a subsystem to be transported in accordance with the transportation of the system in which they reside.

HISTORICAL BACKGROUND: The continued evolution of Target Accuracy Geolocation capability using TDOA/DD is a technology advantage over any other country and has been restricted from release to foreign countries.

REQUIREMENTS DOCUMENT: JSOR GR/CS dated 23 May 84. ROI GBCS dtd Oct 90.

TYPE CLASSIFICATION: Standard, Sep 96.

RELEASEABLE TO SECURITY ASSISTANCE CUSTOMERS: No

EVENT SCHEDULE	FISCAL YEAR	97		98		99		00		01		02					
		QTR				1	2	3	4	1	2	3	4	1	2	3	4
IOT&E CHALS-X					X												
Full Scale Production. CHALS-X(M)						X	-----	-----	-----	-----	-----	-----	-----				

SYNOPSIS: CHALS-X IS A PRECISION LOCATION SYSTEM.

PM, SW

TACJAM-A

PRODUCT MANAGER: LTC Darrell R. Davis,
DSN 987-1479
COMM 732/427-1479
FAX: 732/427-5822
E-Mail: davisd@doim6.monmouth.army.mil

ACQUISITION CATEGORY: III
ACQUISITION PHASE: II - Eng/Manufacturing Dev

PE & LINE: 0604270 / DL12. BZ7326, AB3000

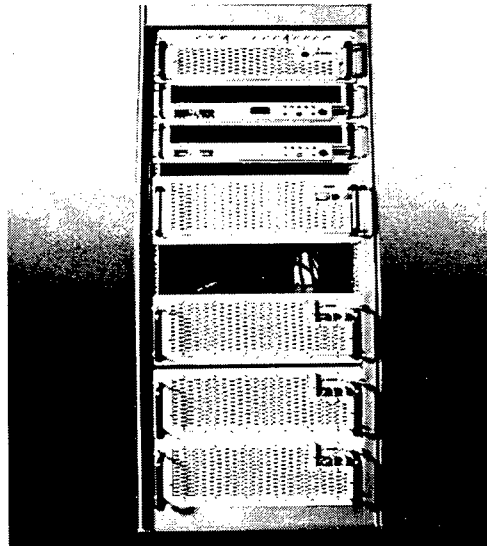

DESCRIPTION: The TACJAM-A system will enhance the Division Commander's ability to out maneuver and kill the enemy by isolating and suppressing enemy fire control and command and control (C2) nets at critical points in the battle; provide electromagnetic overwatch of the threat C2 communications inclusive of both conventional and modern modulations; freeze the enemy in place by jamming C2; and eliminate enemy counterfire by locating High Value Targets (HVTs) for targeting. TACJAM-A consists of state-of-the-art modular and scaleable Electronic Support Measure (ESM) and Electronic Countermeasure (ECM) subsystems configured for use on a variety of air and ground prime movers (tracked, wheeled, airborne and heliborne). As such the TACJAM-A systems are foremost examples of a horizontally integrated system that is here today and is in the right system for Electronic Support, Communications Intelligence, or Electronic Attack in the next conflict.

TRANSPORTATION CHARACTERISTICS / LIMITATIONS: Not Applicable. This is a subsystem to be transported in accordance with the transportation of the system in which they reside.

HISTORICAL BACKGROUND:

- Mar 87 Contract awarded for ESM.
- Jan 93 Prototype Deliveries made (2 ea) (ESM).
- Jul 93 Start E&MD Delivery (ESM).
- Jan 94 Restart ECM effort.
- Jan 95 LPU award of TACJAM-A ESM.
- Nov 95 LRIP ID/IQ Award ESM.

REQUIREMENTS DOCUMENT: GBCS-ROC 18 Oct 90. AQF-ORD Oct 92.

TYPE CLASSIFICATION: Standard, Oct 96.

RELEASEABLE TO SECURITY ASSISTANCE CUSTOMERS: No

EVENT SCHEDULE	FISCAL YEAR	97	98	99	00	01	02
		1 2 3 4	1 2 3 4	1 2 3 4	1 2 3 4	1 2 3 4	1 2 3 4
LPULRP (ESM)	QTR	-----X					
Full Scale Production			X-----			-----X	

SYNOPSIS: TACJAM-A IS AN ELECTRONIC SUPPORT MEASURES (ESM) AND ELECTRONIC COUNTERMEASURES (ECM) SUBSYSTEM PROVIDED AS GFE TO THE IEWCS SYSTEMS.

PO, JPSD

PO, JPSD

RAPID TERRAIN VISUALIZATION ADVANCED CONCEPT TECHNOLOGY DEMONSTRATION

PROJECT MANAGER: Mr. Chris Moscoso,
 DSN 654-1966
 COMM 703/704-1966
 FAX: 703/704-2138
 E-Mail: cmoscoso@nvl.army.mil

ACQUISITION CATEGORY: N/A
ACQUISITION PHASE: N/A

PE & LINE #: 0603734A/DT12

DESCRIPTION: The RTV-ACTD will demonstrate the capabilities required to provide level V elevation data, feature data, and imagery to the warfighter. The RTV-ACTD objective is to integrate and demonstrate key enabling technologies to satisfy Army requirements for rapid production of digital topographic data over a 90 x 90 kilometer area in 72 hours. These requirements are developed and refined by the U.S. Army Training and Doctrine Command (TRADOC) Technology Program Integration Office (TPIO) for Terrain Data at Fort Leonard Wood, MO. The focus of the RTV-ACTD will be on source collection, data generation and transformation of digital topographic data. The ACTD will leverage technologies being developed by other government agencies and industry. These technologies will be integrated in the Joint Precision Strike Demonstration (JPSD) Integration and Evaluation Center (IEC) and analyzed to determine their effectiveness. The IEC facilitates rapid technology integration, and collection of detailed metrics on the performance and cost to produce and use various resolution and fidelity terrain databases. The ACTD will provide a testbed capability to the user to ensure continual feedback on the military value of capabilities. Selected capabilities, whose maturity has been demonstrated in the IEC, will be transitioned to the user testbed for evaluation. The RTV-ACTD will participate in XVIII Abn Corps warfighter exercises and demonstrations to quantify the operational effectiveness of terrain visualization technologies and develop concepts of operations (CONOPS). An objective capability will be delivered to the using unit as leave behind in the year 2000.

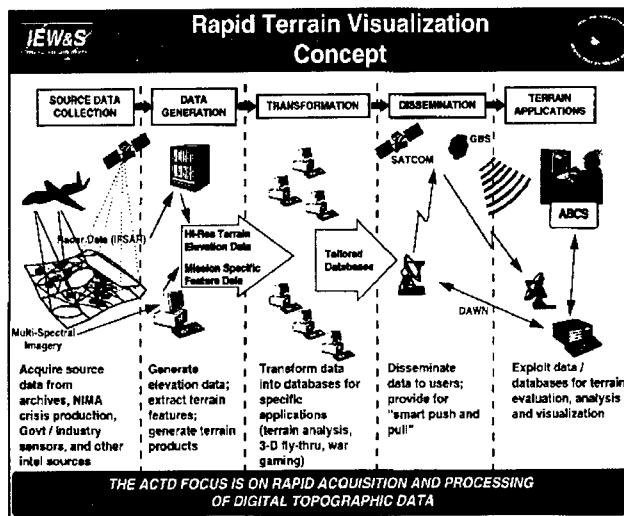

TRANSPORTATION CHARACTERISTICS / LIMITATIONS: N/A

HISTORICAL BACKGROUND:

3 May 95 The DCSINT of the US Army briefed CSA on Battlefield Visualization.
 Jun 95 DASA-R&T directed JPSD-PO to develop a concept for Rapid Battlefield Visualization ACTD.
 1996 JPSD-PO provided pre-ACTD support to the XVIII Airborne Corps and helped establish user testbed.
 Oct 96 RBV-ACTD officially started.

REQUIREMENTS DOCUMENT: ROC not required: Program is ACTD.

TYPE CLASSIFICATION: N/A

RELEASEABLE TO SECURITY ASSISTANCE CUSTOMERS: No

EVENT SCHEDULE	FISCAL YEAR	QTR																			
		97				98				99				00				01			
		1	2	3	4	1	2	3	4	1	2	3	4	1	2	3	4	1	2	3	4
Baseline capability w/surrogate workstations at XVIII Abn Corps		1																			
United Endeavor Phase III		1																			
Support the 525th MI Bde at TF XXI		2																			
Obtain RTV-ACTD Management Plan Approval			4																		
Functional Capability Demonstration 1 at JPSD IEC			4																		
Transition baseline capability to EXFOR for DIV XXI AWE				1																	
Div XXI AWE				1																	
XVIII Airborne Corps Warfighter Exercise (WFX)				3																	
Div WFX				4																	
Functional Capability Demonstration 2 at JPSD IEC				4																	
Initiate upgrade to XVIII Corps capabilities					1																
XVIII Corps WFX					3																
Div WFX					4																
Functional Capability Demonstration 3 at JPSD IEC					4																
Objective Capability established at XVIII Airborne Corps					4																
XVIII Abn Corps WFX													3								
Functional Capability Demonstration 4 at JPSD IEC																	4				
Provide leave-behind support to user														1	2	3	4	1	2	3	4

SYNOPSIS: THE RTV ACTD WILL DEMONSTRATE THE CAPABILITIES REQUIRED TO RAPIDLY PROCESS AND EXPLOIT TERRAIN DATA ENABLING THE WARFIGHTER TO MORE REALISTICALLY VISUALIZE THE BATTLEFIELD.

PEO STAMIS

PEO STAMIS

ARMY DISTANCE LEARNING PROGRAM (ADLP)

PRODUCT MANAGER: Mr. Gary Winkler,
DSN 680-5553
COMM 757/727-5553
FAX DSN 680-5941

ACQUISITION CATEGORY: 1AM
ACQUISITION PHASE: CE/PDRR

PE & LINE #:

DESCRIPTION: Deliver standardized individual training, selected collective training, and self development training to soldiers and units at the right place and right time through the application of multiple technologies.

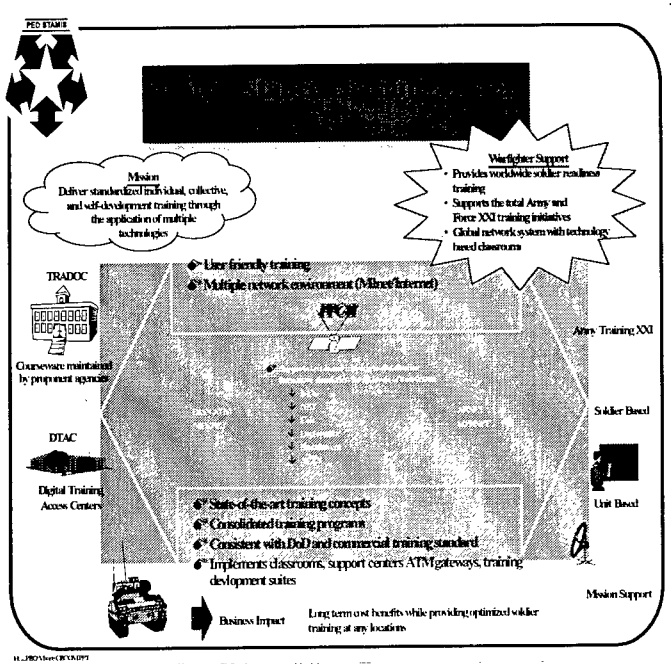

PEO STAMIS

DEFENSE MESSAGE SYSTEM-ARMY (DMS-A)

PRODUCT MANAGER: COL Robert Raiford
 DSN 992-7913
 COMM 732/532-7913

ACQUISITION CATEGORY:
ACQUISITION PHASE: EMD/PF/DOS

PE & LINE #:

DESCRIPTION: Responsible for total Army DMS solution (seamless writer-to-reader, strategic through tactical) serving in excess of 200 worldwide locations including OSD, Joint Staff, CINCs and MACOMS.

The DMS consists of all hardware, software, procedures, standards, facilities and personnel used to exchange messages electronically between organizations and individuals in the DoD. The current systems providing this capability are AUTODIN and E-mail, including messaging and mail capabilities interfaces for allied and commercial systems.

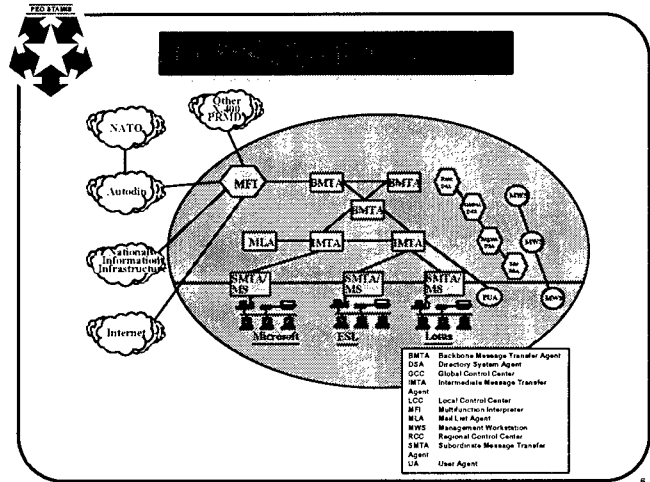

PEO STAMIS

**JOINT COMPUTER-AIDED ACQUISITION
AND LOGISTICS SUPPORT (JCALS)**

PROJECT MANAGER: Mr. Robert Doto,
DSN 992-0400
COMM 732/532-0400

ACQUISITION CATEGORY: ACAT IAM
ACQUISITION PHASE: EMD/PF/DOS

PE & LINE #:

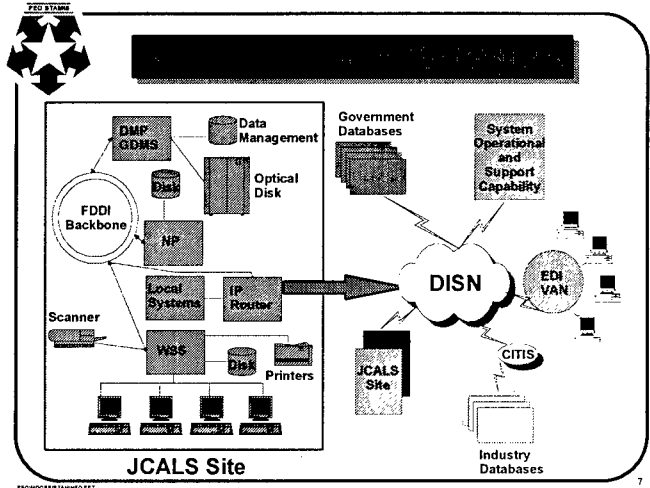

DESCRIPTION: The purpose of the JCALS system program effort is to specify, acquire, implement, and field a Computer-aided Acquisition and Logistic Support (CALs) architecture and its interfaces to supporting systems. The JCALS system will satisfy a Joint Services/Defense Logistics Agency (DLA) need for integrated digital technical information/information management in support of weapon system acquisition and logistics life cycle management. The basis of this need is the requirement to rapidly increase capabilities to receive, distribute, and use logistic technical information in digital form.

PEO STAMIS

**JOINT RECRUITING INFORMATION
SUPPORT SYSTEM (JRISS)**

PROJECT MANAGER: COL Jerry M. Henderson,
DSN 464-7413
COMM 502/626-1101/1102

ACQUISITION CATEGORY: IAM
ACQUISITION PHASE: EMD/PF/DOS

PE & LINE #:

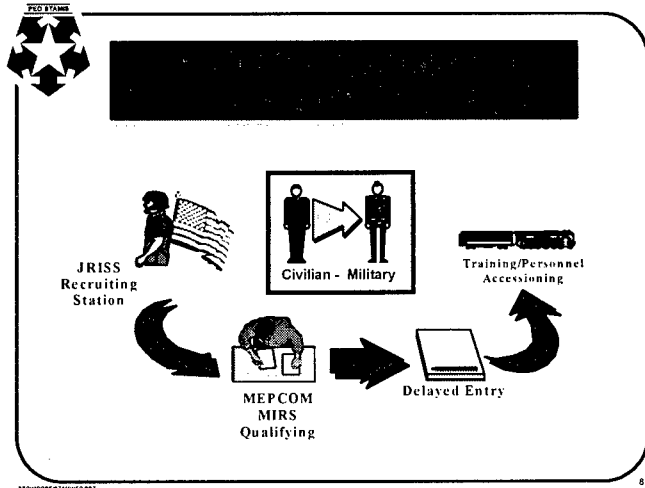

DESCRIPTION: JRISS will provide automation support to field production recruiters, their immediate supervisors, mid and upper level managers and specified recruiting HQs. This support will be provided to all twelve Armed Service Components. JRISS will provide an electronic interface with the United States Military Entrance Processing Command (USMEPCOM) Integrated Resource Systems (MIRS) and individual Service training and personnel systems.

PEO STAMIS

SUSTAINING BASE AUTOMATION (SBA)

PRODUCT MANAGER: Ms. Roxanne C. Austin
 DSN 656-0500
 COMM 703/806-0500

ACQUISITION CATEGORY:
ACQUISITION PHASE: MS

PE & LINE #:

DESCRIPTION: The mission of PM SBA is to serve as a force multiplier in the information war by centrally managing the planning, designing, developing, acquiring and installing of supportable highly complex management information systems and infrastructure for the Warfighter in peace, mobilization, force projection, split-based operations and redeployment.

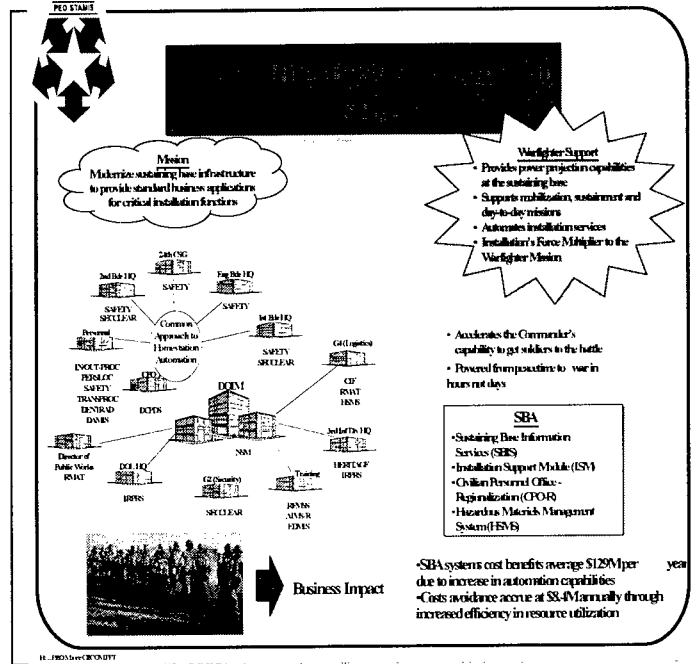

The following are the SBA Projects:

Defense Civilian Personnel Data System-Modernization (Civilian Personnel Office-Regionalization) (CPO-R). The Department of the Army civilian (DAC) workforce is absolutely essential to successful power projection of the Army force. Among many other roles, it operates the power projection installations and sustains the combat force when deployed. OPM SBA is acquiring information technology in support of regional personnel offices and also providing state-of-the-art information technology to these centers when required.

Hazardous Substance Management System (HSMS). In direct support of the Army objective of totally integrating environmental stewardship into installation operations. This migration Corporation Information Management (CIM) system has been designated by Office, Secretary of Defense (OSD) to provide all DoD installations with the automated capability for cradle-to-grave control and visibility, from initial procurement/requisitioning through hazardous waste disposal, of hazardous substances while on installations.

Military Entrance Processing Command (MEPCOM) Integrated Resource System (MIRS). OPM SBA has acquired information technology infrastructure to enhance the processing of new recruits into the Army and the other services. MIRS is a joint system operated by the U.S. MEPCOM at over 60 military entrance processing stations nationwide.

PEO STAMIS

**STANDARD INSTALLATION/DIVISION
PERSONNEL SYSTEM -3 (SIDPERS-3)**

PRODUCT MANAGER: LTC Jenna Noble,
DSN 656-4232
COMM 703/806-4232

ACQUISITION CATEGORY: 1AM
ACQUISITION PHASE: PFDOS

PE & LINE #:

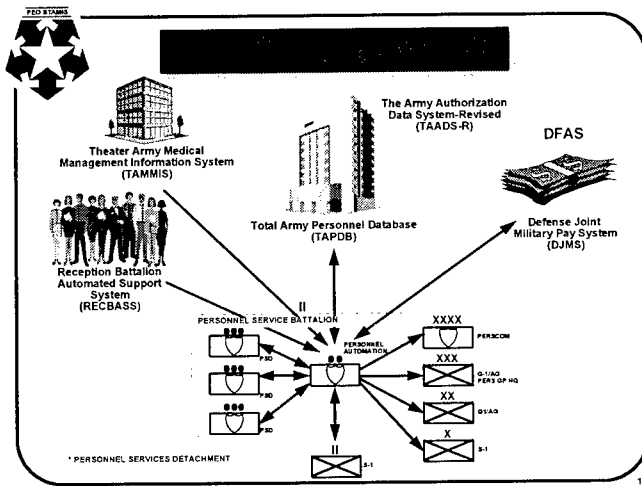

DESCRIPTION: SIDPERS-3 is an automated military personnel system that directly supports the Army's warfighting ability by providing commanders at all echelons from the field to the HQ with necessary personnel information to make accurate decisions and effectively manage personnel assets. The system will serve the Active Army in peacetime and the Total Army during war and mobilization. The system will replace the current system that was fielded in 1972 with modern NDI hardware, a relational database management system structure and the ability to update personnel records from the top to the bottom of the system every 24 hours.

SIDPERS-3 uses NDI hardware to support standardized software that operates in an Open Systems Environment. It will be fielded to 54 sites around the Army. Quantities of equipment procured are dependent on the specific configuration of the site.

PEO STAMIS

**TRANSPORTATION COORDINATOR -
AUTOMATED INFORMATION FOR MOVEMENT
SYSTEMS II (TC-AIMS-II)**

PROJECT MANAGER: Mr. Stanford Polonsky,
COMM 703/275-9300

ACQUISITION CATEGORY: 1AM
ACQUISITION PHASE: CE/PDRR

PE & LINE #:

DESCRIPTION: TC-AIMS-II supports the warfighter in the planning and execution of the deployment, sustainment, and redeployment of forces during peace and war.

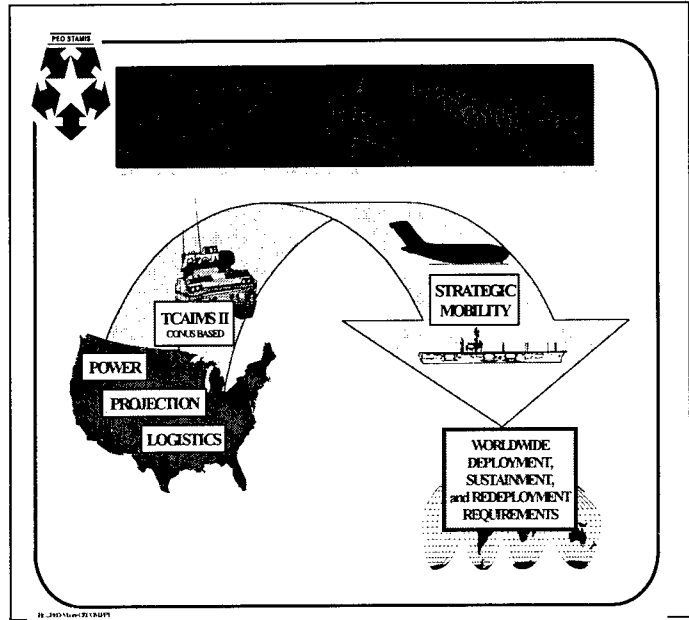

TC-AIMS-II is a toolbox of functionalities that facilitates the movement of personnel, equipment, and supplies during peace and war, and provides visibility of those assets from home station to the conflict and back.

PEO STAMIS

INTEGRATED LOGISTICS SYSTEMS (ILOGS)

PROJECT MANAGER: Mr. Peter O. Johnson,
 COMM 804/734-7665
 DSN 687-7665

ACQUISITION CATEGORY:
ACQUISITION PHASE:

PE & LINE #:

DESCRIPTION: ILOGS provides the oversight for the following systems: DAMMS-R, ICS3, SAAS, SAMS, SARSS and ULLS/SPBS-R that follow this page.

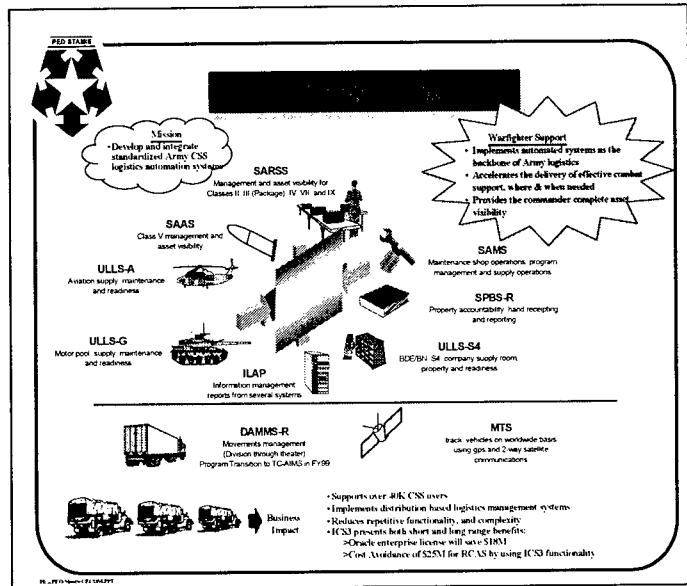

PEO STAMIS

**DA MOVEMENTS MANAGEMENT SYSTEM-
REDESIGN (DAMMS-R)**

PROJECT MANAGER: Mr. Herbert Andresen (Acting),
DSN 687-6047
COMM 804/734-6047
FAX 804/734-7553

ACQUISITION CATEGORY: ACAT III
ACQUISITION PHASE: PFDOS

PE & LINE #:

DESCRIPTION:

DAMMS-R provides centralized information management to support movements management, transportation operations, and common user transport asset control functions within any theater of operation.

The functional requirements of the DAMMS-R system are grouped into seven major subsystems or modules. They are the shipment management module (SMM), the movement control team operations subsystem (MCT), the mode operations subsystem, the highway regulations module, the convoy planning module, the theater addressing subsystem (TAS), and the operational movements programming module. DAMMS-R operates on non-developmental item (NDI) computers available through standard requirements contracts. The system architecture provides a local area network (LAN) in organizations that require more than one DAMMS-R computer.

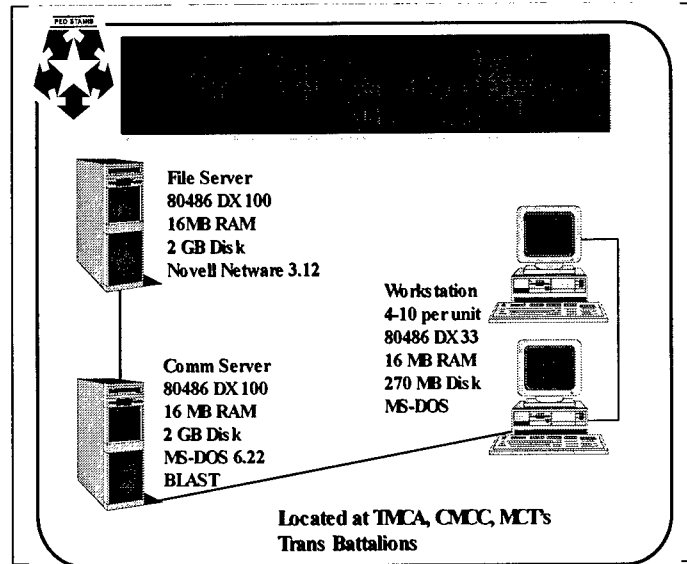

PEO STAMIS

INTEGRATED COMBAT SERVICE SUPPORT SYSTEM (ICS3)

PRODUCT MANAGER: LTC Joseph Brito
DSN 687-7688
COMM 804/734-7688

ACQUISITION CATEGORY: TBD
ACQUISITION PHASE: PDRR/EMD

PE & LINE #:

DESCRIPTION: ICS3 will be the business automation enabler for the total Army Combat Service Support (CSS) mission area and will constitute the Army portion of the Global Combat Support System (GCSS). ICS3 will consolidate the CSS functions of manning, arming, fixing, fueling, moving and sustaining soldiers and their systems into one seamless application.

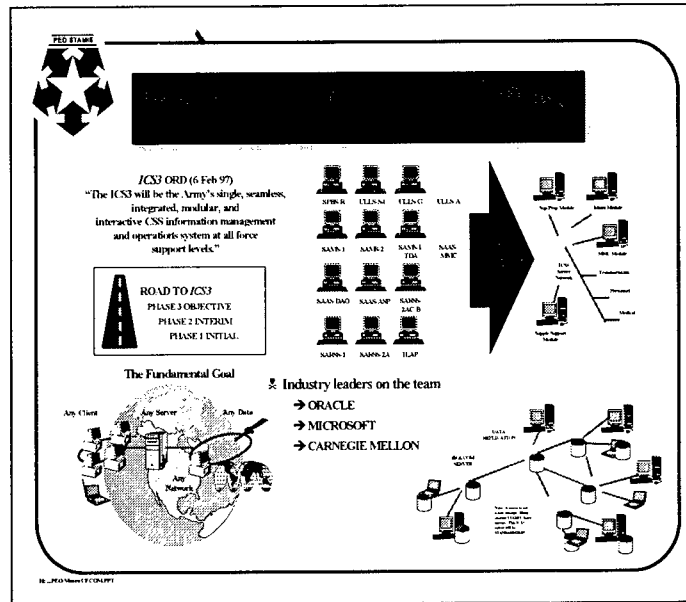

PEO STAMIS

**STANDARD ARMY AMMUNITION SYSTEM
(SAAS)**

PRODUCT MANAGER: Mr. Gary Schuller,
DSN 687-7686
COMM 804/734-7686

ACQUISITION CATEGORY: ACAT III
ACQUISITION PHASE: PFDOS

PE & LINE #:

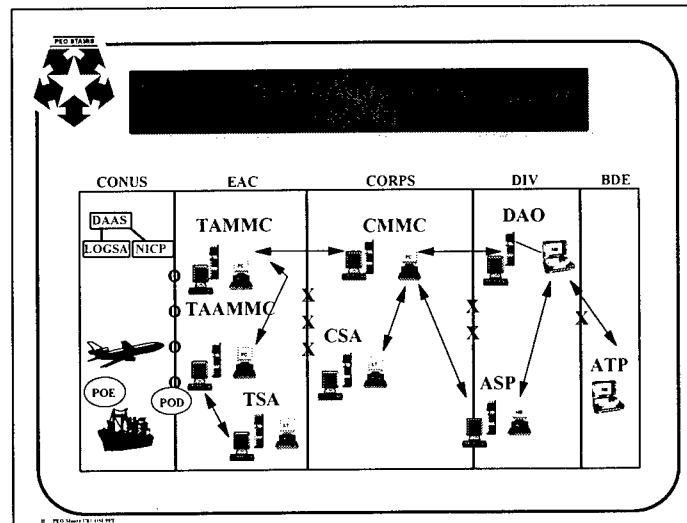

DESCRIPTION: SAAS program provides information management systems supporting ammunition management functions on the battlefield and in OCONUS MACOMS. Current development effort modernizes systems fielded in the mid to late 80's and provides improvements/functionality as identified during operations Desert Shield and Desert Storm. New system design accommodates the force projection Army.

SAAS-1/3 automates ammunition management functions in the Army Corps and Theater materiel management centers. (Fielded). SAAS-4 automates the receipt, storage, and issuing operations at Army operated ammunition supply points. (Fielded). SAAS-DAO - automates the ammunition operations within the division ammunition office. (Fielded). SAAS-MOD - merges the fielded SAAS baselines into a single Open System compliant application. "Modular" design allows selection of functions to support level of employment. (Development). Will operate on a variety of platforms from "laptops" to mini-computers operating LANS with PC class workstations.

PEO STAMIS

STANDARD ARMY MAINTENANCE SYSTEM (SAMS)

PRODUCT MANAGER: LTC Joseph Brito,
DSN 687-7688
COMM 804/734-7688

ACQUISITION CATEGORY: 1AC
ACQUISITION PHASE: PF/DOS

PE & LINE #:

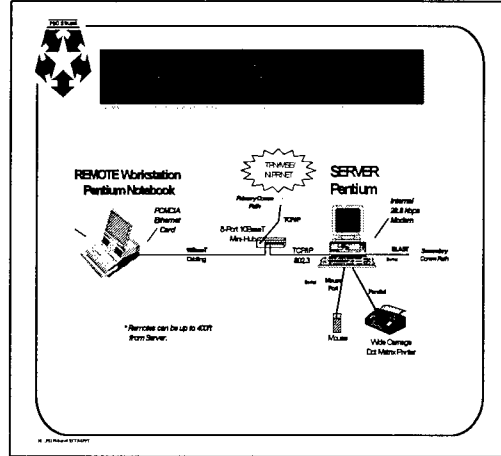

DESCRIPTION: SAMS provides information management to supporting maintenance operations at the Direct Support, General Support, and Installation activities (both TOE and TDA units). Two current development efforts are under way.

SAM-I/TDA automates installation maintenance operations, man-hour utilization, and shop supply functions. (Development). Will operate on mini-computers managing a multi-user LAN. SAMS-1 and SAMS-2 automates direct and general support maintenance operations, shop supply functions, readiness reporting, and man-hour utilization in the TOE Army. (Fielded). STANDARD MAINTENANCE SYSTEM 1 & 2 (SMS) merges the functions of the above baselines into Open System compliant applications. (Under Development).

PEO STAMIS

**STANDARD ARMY RETAIL SUPPLY SYSTEM
(SARSS)**

PRODUCT MANAGER: LTC Ricky Daniels,
DSN 687-7683
COMM 804/734-7683

ACQUISITION CATEGORY: 1AM
ACQUISITION PHASE: PF/DOS

PE & LINE #:

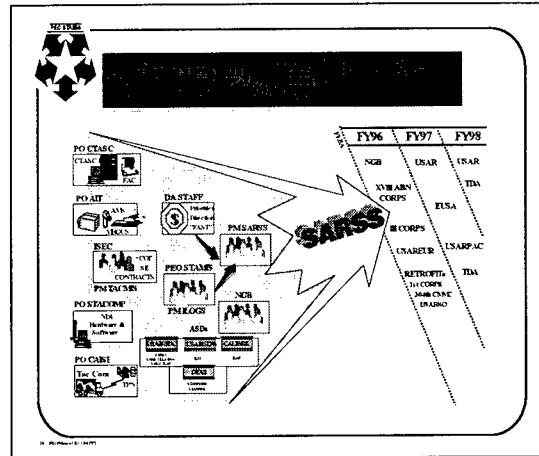

DESCRIPTION: SARSS will provide automated stock record accounting and supply management for Classes II, III (package), IV, VII, and IX (less COMSEC and Mags Supply) within the theater of operations and CONUS. SARSS is comprised of interrelated sub-systems: SARSS-1, SARSS 2A, and SARSS 2B.

SARSS-1 performs time sensitive activities of receiving, storing, and issuing at the Supply Support Activity or storage site and operates currently on non-developmental item (NDI) COTS hardware. SARSS-2A executes supply management functions such as resource allocations, excess disposition, and redistribution. It operates on the NDI hardware platform at the Materiel Management Center (MMC) level of the Division and Separate Brigades and coexists on the CTASC-II hardware platform with SARSS-2B at the Corps Support Command MMC (CMMC), Theater Army Commands, Theater Army Support Commands, and installations. SARSS-2B executes less time sensitive functions such as document history maintenance, catalog maintenance, and requirements determination at the Materiel Management Centers of Corps Support Commands (CMMC), Theater Army Area Commands (TAMMC), and CONUS installations.

PEO STAMIS

UNIT LEVEL LOGISTICS SYSTEM (ULLS)

PRODUCT MANAGER: Mr. Nicholas Flaim,
DSN 687-7689
COMM 804/734-7689

ACQUISITION CATEGORY: 1AM
ACQUISITION PHASE: PFDOS

PE & LINE #:

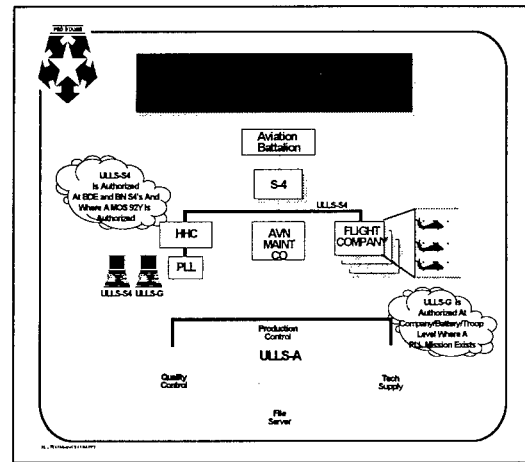

DESCRIPTION: ULLS is a standard, automated, logistics system for unit Prescribed Load List (PLL) and maintenance management operations. Repair parts supply functions, maintenance management operations, aircraft records, and historical data are automated to improve accuracy and timeliness.

PEO STAMIS

TACTICAL MANAGEMENT INFORMATION SYSTEMS (TACMIS)

PROJECT MANAGER: Mr. Robert A. Ragans (Acting),
 DSN 656-8666
 COMM 703/806-8666

ACQUISITION CATEGORY: IV
ACQUISITION PHASE: N/A

PE & LINE #:

DESCRIPTION: TACMIS is responsible for development, acquisition, testing, integration logistics support, production and fielding of tactical/non-tactical management information to include both hardware and supporting software to the active and reserve Army, Department of Defense activities and foreign military agencies under the Project Officer's direct control, and ensures resources are managed within current regulations and policies. Provides oversight for the systems that follow: AIT, CAISI, CTASC, PERMS and STACOMP.

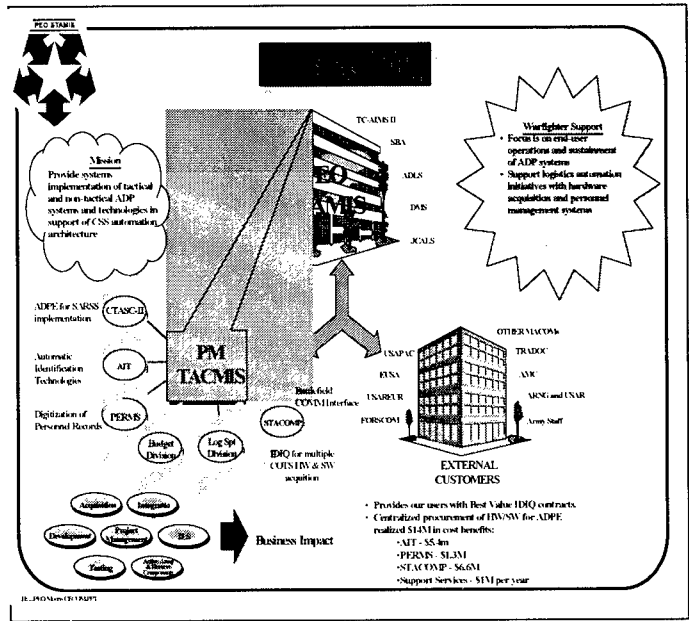

PEO STAMIS

AUTOMATED IDENTIFICATION TECHNOLOGY (AIT)

PROJECT MANAGER: Ms. Susan Vickers
DSN 656-8110
COMM 703/806-4110
FAX: 703-806-4103

ACQUISITION CATEGORY: N/A
ACQUISITION PHASE: N/A

PE & LINE #:

DESCRIPTION: AIT develops and implements all plans and activities for DoD-Wide acquisition, Army and other Federal agency implementations of Automatic Identification Technologies and Radio Frequency Identification. AIT manages a contract vehicle to provide commercial hardware peripherals used to automate data collection, making possible a number of initiatives to increase productivity and operational efficiency throughout Department of Defense (DoD).

TRANSPORTATION CHARACTERISTICS / LIMITATIONS: N/A

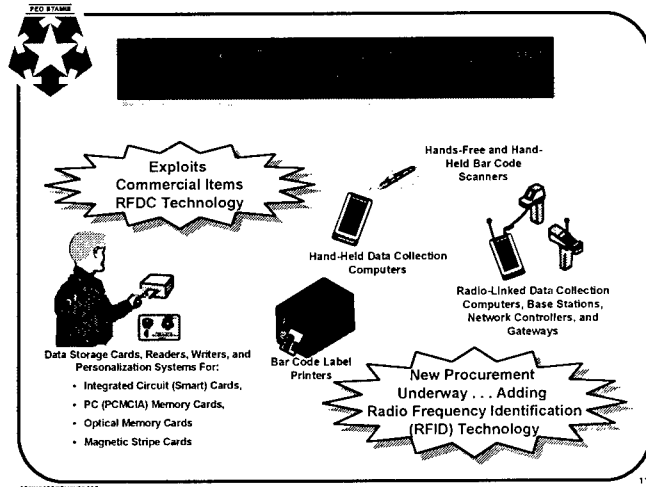

PEO STAMIS

**CORPS THEATRE ADP SERVICE CENTER,
PHASE II (CTASC II)**

PROJECT OFFICER: LTC Allen Forte,
DSN 656-3887
COMM 703/806-3887
FAX: 703/806-3903

ACQUISITION CATEGORY: ACAT IV
ACQUISITION PHASE: PFDOS

PE & LINE #:

DESCRIPTION: CTASC-II is an Army Automated Information System (AIS) employed at Corps and Echelons above Corps levels to provide ADP processing support for Combat Service Support (CSS) logistical support agencies.

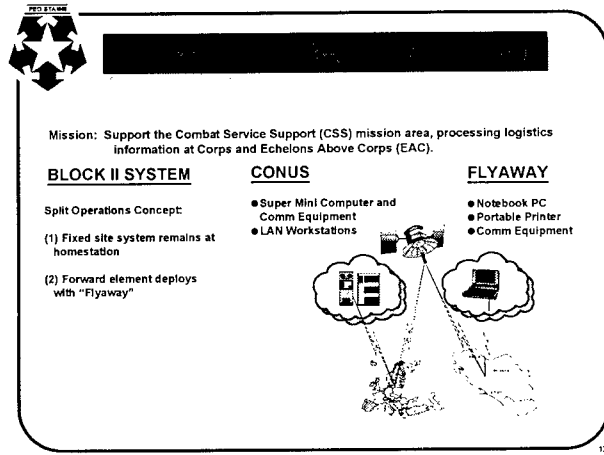

PEO STAMIS

PERSONNEL ELECTRONIC RECORD MANAGEMENT SYSTEM (PERMS)

PRODUCT MANAGER: Edgar Lewin (Acting),
DSN 656-3259/4259
COMM 703/806-3259/4259

ACQUISITION CATEGORY: 1AC
ACQUISITION PHASE: PFDOS

PE & LINE #:

DESCRIPTION: PERMS directly supports the Army's military personnel records management mission in war, mobilization and peace as required by Title 10, US Code (Armed Forces) and Title 44, US Code (Records Management by Federal Agencies). PERMS will provide an automated system for record keeping functions at four headquarters level Army Personnel Record Management Centers.

PERMS will replace the current military personnel paper and microfiche record keeping architecture with commercially available optical digital imagery (ODI) technology to enhance record quality and optimize record storage and retrieval operations. The system will consist of hardware, software, and telecommunications to process digital images. PERMS sites are: the US Army Reserve Personnel Center (ARPERCEN), the Management Support Division (MSD) and Enlisted Records and Evaluation Center (EREC) within the US Total Army Personnel Command (PERSCOM) and the National Guard Bureau (NGB).

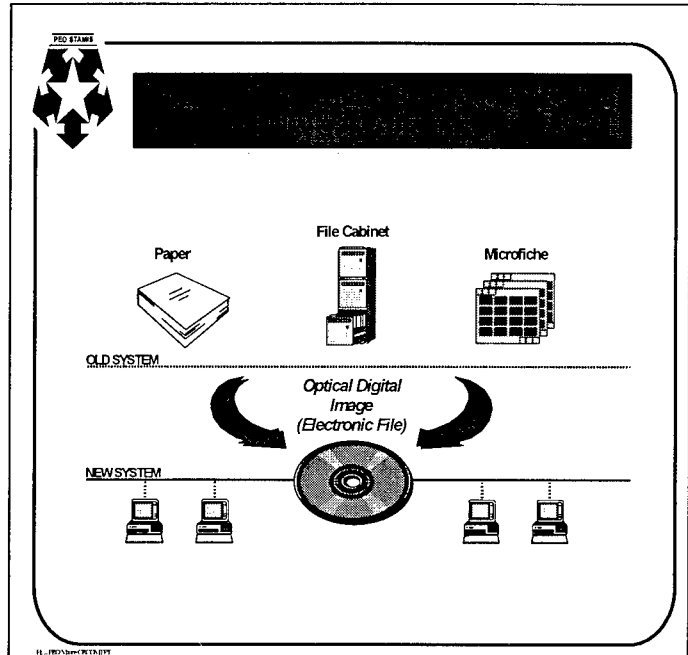

PEO STAMIS

STAMIS TACTICAL COMPUTERS (STACOMP)

PRODUCT OFFICER: Mr. Robert Bradley,
DSN 656-3956
COMM 703/806-3956
FAX: DSN 656-4103

ACQUISITION CATEGORY: N/A
ACQUISITION PHASE: N/A

PE & LINE #:

DESCRIPTION: STACOMP systems support the Standard Army Management Information Systems (STAMIS) tactical and selected sustaining base hardware communications and non-applications software requirements for the Army to include Logistics (Transportation, supply and maintenance), medical and personnel. STACOMP is designed to provide follow-on systems in support of expanding CSS mission requirements. STACOMP supports the following PEO STAMIS systems: SARSS, SAAS, SAMS, DAMMS-R and ULLS/SPBS-R.

STACOMP is an evolution of the TACCS/TACCS-E which provided ruggedized systems to support Combat Service Support (CSS) missions from Division to Battalion. The STACOMP is Commercial Off-the-Shelf (COTS) computer configurations ranging from notebooks to fully integrated and networked servers and desktop computers. STACOMP systems are transportable and user friendly.

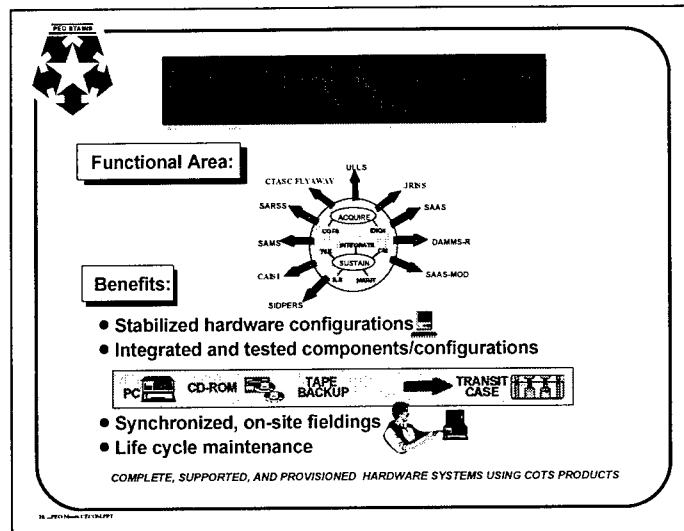

CECOM

LRC

CCS AVIONICS

CCS/AVIONICS

AN/ARC-164(V), HAVE QUICK II (HQ II)

PROJECT OFFICER: Mr. Bob Mansfield,
 DSN 992-3800
 COMM 732/532-3800
 FAX: DSN 992-5800
 E-Mail: mansfiel@doim6.monmouth.army.mil

ACQUISITION CATEGORY: IV
ACQUISITION PHASE: MS IV Operations/Support

PE & LINE #: R13541

DESCRIPTION: The HAVE QUICK II radio set provides a 7,000 channel UHF tunable receiver; an auxiliary guard receiver (nominally 243.000 megahertz) and 10-watt carrier transmitter for normal AM voice and Anti-Jam (AJ) Frequency Hopping communication mode. HAVE QUICK II radio set provides additional AJ improvements and features from the original HAVE QUICK radio.

TRANSPORTATION CHARACTERISTICS / LIMITATIONS: 12.82 lbs.

HISTORICAL BACKGROUND:

- Mar 82 JCS directs all services to use HQ II for Electronic Counter-Countermeasure (ECCM) for UHF band.
- Feb 90 Materiel Change for HQ II implementation approved by CG, CECOM.
- Jun 92 First Army HQ I to HQ II modification kit applied.
- Jul 95 Army Ground Radio AN/GRC-240 fielded.

REQUIREMENTS DOCUMENT: O&O Plan for Army Aviation UHF Radios, Nov 91. CARDS # 0522P; Technical manual TM 11-5821-356-23; Fort Monmouth Training Video PAN NO. A0348-VTC-97-0053

TYPE CLASSIFICATION: Standard A approved 1987. Panel (RT-1518C/ARC-164), remote (RT-1504, C-11721, MT-4708), and MIL-STD-1553B (RT-1614) versions.

AN/ARC-164 MOD KITS to convert older radios up to three standard types.

NOMENCLATURE	P/N	NSN	HARDWARE	DESCRIPTION	MWO #
MK-2804/ARC-164	743967-806	1680-01-413-1871	RT-1518 TO RT-1518C	red to anvis/fill port	MWO-11-5821-356-23-5
MK-2805/ARC-164	744279-801	1680-01-400-3211	C-11721 & RT-1518 TO C-9682 () RT-1518C	anvis remote & red panel to red remote & anvis panel	MWO-11-5821-356-23-2
MK-2806/ARC-164	744287-801	1680-01-406-3717	RT-1504 or -1518() & C-11721 TO RT-1518C	rt & control to anvis panel	MWO-11-5821-356-23-4
MK-2807/ARC-164	743941-801	1680-01-406-2328	RT-1504 or -1518() TO RT-1614	rt to mil-std-1553b	MWO-11-5821-356-23-3
MK-2808/ARC-164	741527-801	1680-01-406-3716	RT-1167C TO RT-1518	hqi to hqi	MWO-11-5821-356-23-1

RELEASEABLE TO SECURITY ASSISTANCE CUSTOMERS: Per HQII/IIA security classification guide dated 1 Jun 90 Hanscom Air Force Base, MA. Distribution authorized to Department of Defense and US DoD contractors only (Critical Technology) (28 Feb 95). Other requests shall be referred to SAF/IAD 1010 Air Force Pentagon Washington, DC 20330-1010.

EVENT SCHEDULE	FISCAL YEAR											
	97		98		99		00		01		02	
	QTR		QTR		QTR		QTR		QTR		QTR	
Training	-----4											
Modification Kits (upgrade)	-----		---2									

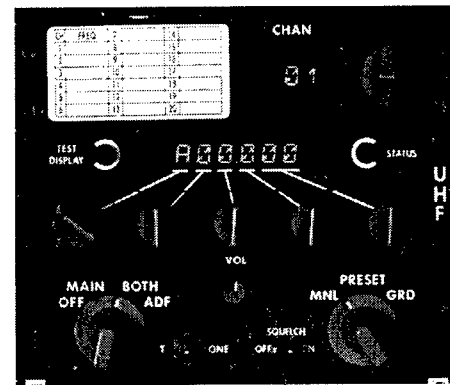

RT-1518C

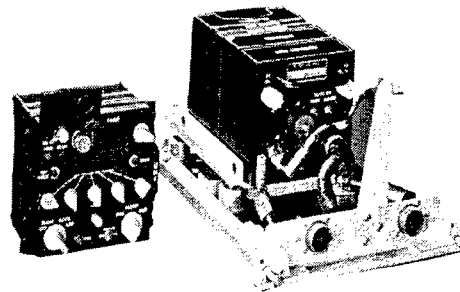

C-11721

RT-1504 IN MT-4708

SYNOPSIS: HQ II PROVIDES THE ARMY THE ABILITY TO COMMUNICATE WITH THE AIR FORCE, NAVY, AND NATO IN UHF-AM MODE. THE COMMUNICATIONS BAND FOR TACTICAL AIR OPERATIONS.

CCS/AVIONICS

AN/ARC-220(V) AND AN/VRC-100(V) HIGH FREQUENCY RADIO

PROJECT MANAGER (PM AEC Field Office): James Mueller,
 DSN 992-2320
 COMM 732/532-2320
 FAX: DSN 992-4441
 E-Mail: muellerj@doim6.monmouth.army.mil

ACQUISITION CATEGORY: III
ACQUISITION PHASE: III Production

PE & LINE #: PE 64420 Project: C97

DESCRIPTION: The AN/ARC-220(V) High Frequency Radio will provide secure and nonsecure voice and data communications at Non Line Of Sight (NLOS) distances with Automatic Link Establishment (ALE) and Electronic Countermeasures (ECCM) capabilities in the 2.000-29.999 Mhz frequency range. The AN/ARC-220(V) and its ground version, the AN/VRC-100(V) will replace the AN/ARC-199(V) and AN/VRC-86(V) respectively. Secure communications will be achieved through the use of the KY-100 Crypto Set. The AN/ARC-220(V)1 consists of three line replaceable units; a Receiver-Transmitter (RT), a Power Amplifier Coupler (PAC), and Control Display Unit (CDU). The AN/ARC-220(V)2 is for bussed (1553) aircraft and consists of just the RT and PAC. The AN/VRC-100(V)1 consists of the three LRU's housed in a metal casing along with a power supply and speaker. The AN/VRC-100(V)2 is the AN/VRC-100(V)1 mounted on a HMMWV along with associated brackets and antennas. The AN/VRC-100(V)3 is for Echelons Above Corps and consists of the AN/VRC-100(V)1 with the AS-3791/G Broadband Antenna.

TRANSPORTATION CHARACTERISTICS / LIMITATIONS: AN/VRC-100(V)1 Data: Length - 23.00 inches, Width - 22.87 inches, Height - 8.75 inches, Weight - 88 pounds. No transport limitations.

HISTORICAL BACKGROUND:

26 Feb 94 NOE COMM ORD Approved.
 28 Jul 94 Milestone I/II In Process Review Approval.
 8 Aug 94 EMD/Production Contract Awarded to Rockwell Collins.
 30 Sep 96 Limited Production Authorized.
 1 Oct 96 First Production option awarded.

REQUIREMENTS DOCUMENT: NOE COMM Operational Requirement (26 Feb 94).

TYPE CLASSIFICATION: Limited Procurement (LP) approved on 30 Sep 96.

RELEASEABLE TO SECURITY ASSISTANCE CUSTOMERS: Yes, but only in the V3 or V4 version.

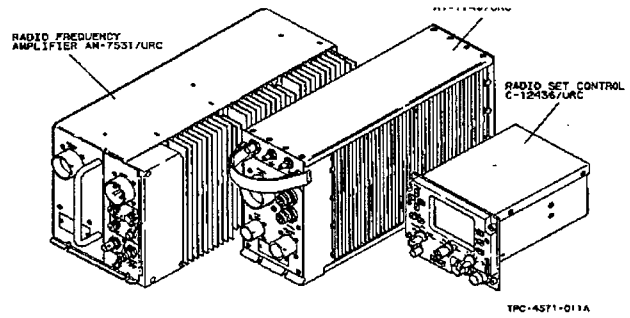
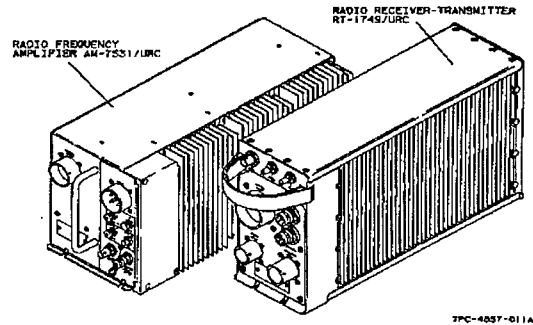

Figure 1-0. Radio Set AN/ARC-220(V)1



7PC-4057-011A

EVENT SCHEDULE	FISCAL YEAR	QTR																							
		97				98				99				00				01				02			
IOT&E		3																							
Milestone III IPR						1																			
Second Production Option Award						1																			
FUED (USASOC)						1																			
Worldwide Fieldings						1								4											

SYNOPSIS: THE AN/ARC-220(V) AND AN/VRC-100(V) HF RADIOS PROVIDE SECURE AND NON SECURE VOICE AND DATA COMMUNICATIONS WITH ALE AND ECCM AT NON LINE OF SIGHT DISTANCES.

CCS/AVIONICS

AN/ASC-15B/C, COMMUNICATIONS CENTRAL - CONSOLE

PROJECT LEADER: Mr. James MacElderry,
DSN 992-4605
COMM 732/532-4605

ACQUISITION CATEGORY: N/A
ACQUISITION PHASE: MS III Production/Deployment

LIN & BLIN #: C59313 AA0710

DESCRIPTION: The AN/ASC-15B/C console functions as an airborne or ground command post providing tactical voice/data communications in both secure and nonsecure modes. AN/ASC-15B/C is interfaced with the aircraft or ground auxiliary equipment to function as a secure/nonsecure automatic retransmission station and satellite communications command post and to provide channel scanning, intercommunication facilities for up to ten users and communication management for up to four operators. AN/ASC-15B/C provides AM and FM communications in the applicable HF, VHF, and UHF frequency ranges and provides NATO and Tri-Service interoperability during all types of military operations.

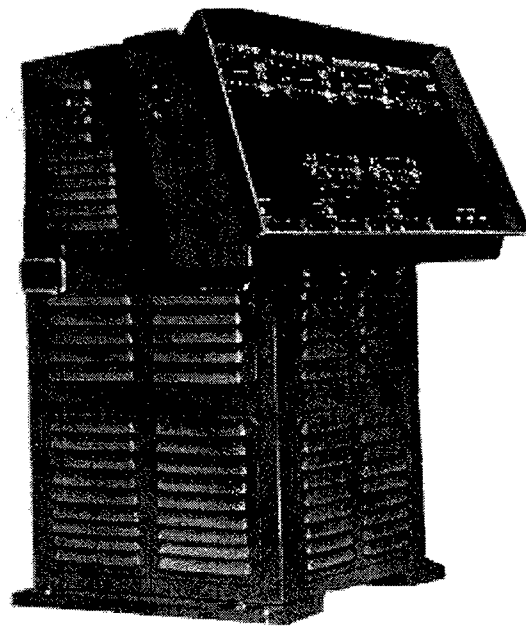

TRANSPORTATION CHARACTERISTICS / LIMITATIONS: Total Volume - 178 = cubic ft, Weight = 1658 lbs.

HISTORICAL BACKGROUND:

Jul 87 Air Worthiness Qualification.
Jul 87-Sep 87 User Testing.
Aug 87-Sep 88 Contract Modifications for an additional 26 systems (total 34 systems).
Sep 90-Jan 91 Unpriced contract awards for 10 systems to support Desert Storm.
Jun 92 Contract award - four systems.
Sep 92 Contract award - seven systems.

REQUIREMENTS DOCUMENT: ROC, March 1991.

TYPE CLASSIFICATION: Limited Production - Urgent approved.

RELEASEABLE TO SECURITY ASSISTANCE CUSTOMERS: Yes, but only to countries authorized to receive Have Quick II.

SYNOPSIS: AN/ASC-15B/C PROVIDES BATTEFIELD COMMANDERS WITH THE C2 CAPABILITY FOR JOINT SERVICE OPERATIONS TO DIRECTLY CONTROL AND INFLUENCE THE BATTLE.

CCS/AVIONICS

AN/ASN-128B DOPPLER/GPS NAVIGATION SET

PROJECT MANAGER: Kim Dahabsu,
 DSN 992-3168
 COMM 732/532-3168
 FAX: DSN 992-4441
 E-Mail: dahabsu@doim6.monmouth.army.mil

ACQUISITION CATEGORY: III
ACQUISITION PHASE: Production/Deployment

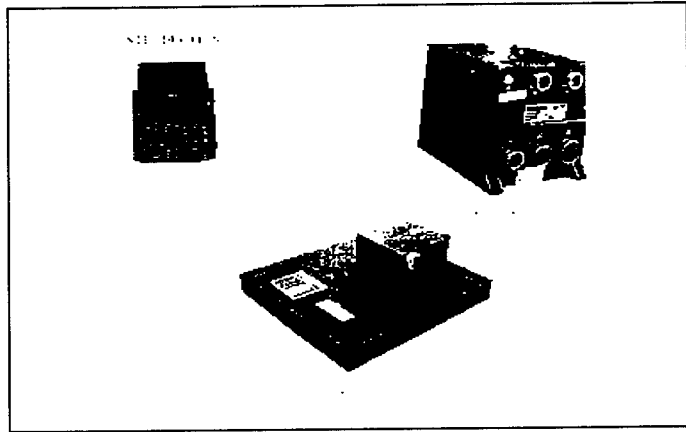

PE & LINE #:

DESCRIPTION: The AN/ASN-128B Doppler/GPS Navigation Set is an avionics system modified from an AN/ASN-128 Lightweight Doppler Navigation Set with the addition of an embedded Global Positioning System (GPS) receiver module. The system consists of three components: the CV-3338A Signal Data Converter (SDC), CP-1252C Computer Display Unit (CDU) and RT-1193 Receiver Transmitter Antenna. The system will be installed into UH-60 A/L Black Hawk and CH-47D Chinook aircraft. The system provides continuous velocity, position and steering information to the pilot. It provides distance, bearing and time to a selected destination as well as track angle error and distance off course to assist with navigation. The Doppler and GPS work in synergy; the GPS accurately initializes and automatically updates Doppler present position. During the retrofit process AN/ASN-128 systems are removed from the aircraft at OLR sites and replaced with AN/ASN-128B delivered directly from the contractor. The RTA is not modified, therefore, not removed from the aircraft.

TRANSPORTATION CHARACTERISTICS / LIMITATIONS: CDU, 7lbs, 6.5"x5.75"x6.0"; SDC, 13.5lbs, 9.6"x7.6"x7.8"; RTA, 10.5lbs, 14.6"x13.5"x1.95".

HISTORICAL BACKGROUND:

- Mar 93 GEC-Marconi contracted to deliver System Specification.
- Jul 93 GEC-Marconi contracted to deliver three prototype systems.
- Jul 95 GEC-Marconi contracted to deliver 1693 systems over five years.
- Mar 97 Contract modified to accelerate program and increase FY98 deliveries.
- Jun 97 Contract modified to incorporate GPS GRAM ECP.

REQUIREMENTS DOCUMENT: N/A

TYPE CLASSIFICATION: N/A

RELEASEABLE TO SECURITY ASSISTANCE CUSTOMERS: No

<u>EVENT SCHEDULE</u>	<u>FISCAL YEAR</u>											
	97		98		99		00		01		02	
	QTR		1 2 3 4		1 2 3 4		1 2 3 4		1 2 3 4		1 2 3 4	
Production Phase									-2			

SYNOPSIS: THE AN/ASN-128B IS AN AN/ASN-128 INCORPORATED WITH GPS CAPABILITY.

CCS/AVIONICS

AN/AYD-1 PERSONNEL LOCATOR SYSTEM

PROJECT LEADER: Mr. James MacElderry,
DSN 992-4605
COMM 732/532-4605

ACQUISITION CATEGORY: IV
ACQUISITION PHASE: IV - Operations and Support

PE & LINE #:

DESCRIPTION: The AN/AYD-1 Personnel Locator System (PLS) consists of the PRC-112 Radio (Motorola), ARS-6 Personnel Locator (Cubic Corp.) and KY-913 Program Loader (Motorola). The ARS-6 sends out interrogation bursts during combat search and rescue missions looking for PRC-112 radios. If the frequency and ID code of the ARS-6 burst is correct, the PRC-112 sends back a 0.4 second reply to the ARS-6 that provides range and steering information to the pilot. The PRC-112 uses unencrypted voice, beacon and transponder modes but there is also a PRC-112A used by the black world that has built-in COMSEC.

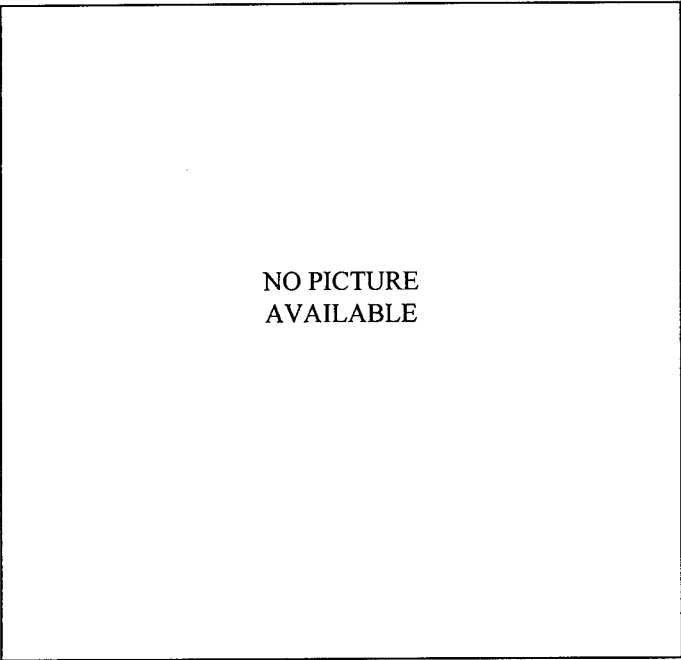

TRANSPORTATION CHARACTERISTICS / LIMITATIONS: Receiver/Transmitter - L: 12.48" W: 7.59" H: 7.8" Wgt: 21.75 lbs.
Control Display unit - L: 4.0" W: 5.75" H: 3.0" W: 2.87 lbs. Remote Display Unit - L: 1.5" w: 3.0" H: 1.87" W: .57 lbs.
Mounting Base - L: 15.75" W: 7.92" H: 1.73" W: 2.1 lbs. Antenna Switching Unit - L: 7.6" W: 1.28" H: 5.6" W: 1.38 lbs.

HISTORICAL BACKGROUND:

REQUIREMENTS DOCUMENT: USAF ROC for PRC-112 dated 1969. US Army ROC for ARS-6 dated 1981.

TYPE CLASSIFICATION: AN/PRC-112 and AN/ARS-6 T/C STD in 1989.

RELEASEABLE TO SECURITY ASSISTANCE CUSTOMERS: Yes

SYNOPSIS: DOWNED PILOT RESCUE RADIO SYSTEM.

CCS/AVIONICS

**AN/FSC-92, AIR TRAFFIC CONTROL
COMMUNICATIONS SWITCHING SYSTEM
(ATCCSS)**

PROJECT MANAGER: Mr. Norman Horstman,
DSN 992-4175
COMM 732/532-4175

PRODUCT MANAGER: PM ATC, DSN 693-2003

ACQUISITION CATEGORY: IV
ACQUISITION PHASE: MS IV Operations/Support

PE & LINE #:

DESCRIPTION: The Air Traffic Control Communications Switching System AN/FSC-92(V) is a distributed micro-processor controlled system which integrates radio, intercom, and landline (telephone) communications. The primary purpose of the system is to establish air traffic control communications in those facilities where it is installed. The system consists of a select number of operator consoles and rackmounted central (switching/line termination) equipment.

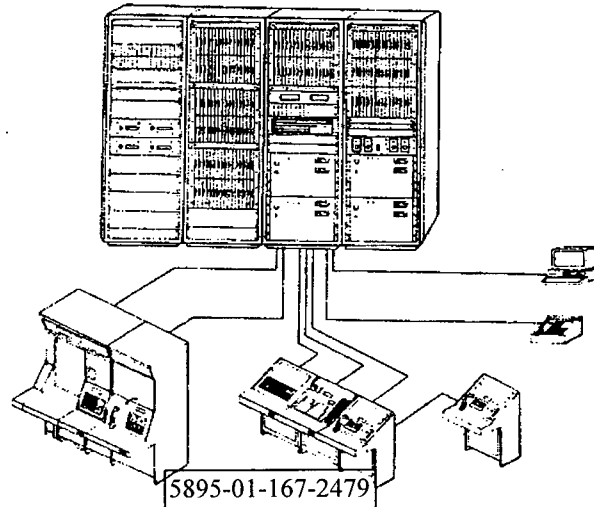

The radiophone feature provides the required interfaces to establish radio communications between the operators and pilots in aircraft. The intercom provides indirect access two-way audio communications between the operator consoles. The landline communications enable local operators to talk to operators at remote locations via the telephone. The system also features point-to-point access buttons which provide immediate operator-to-operator communications.

TRANSPORTATION CHARACTERISTICS / LIMITATIONS: LTSA 31.14 x 80" Consoles 24 x 40.

HISTORICAL BACKGROUND:

- Dec 81 Contract award, Denro Labs, Inc., Qty 45.
- Feb 85 First Installation at Libby Army Airfield, Fort Huachuca, AZ.
- Sep 92 AN/FSC-92 transitioned to SMD for Program Management.
- Feb 94 Installation began at Illesheim Army Airfield, Germany.
- Sep 94 Quality Assurance and Testing completed at Illesheim Army Airfield, Germany.
- FY95 EPROM Support for the AN/FSC-92 will be provided through Denro.

REQUIREMENTS DOCUMENT:

TYPE CLASSIFICATION: STDLCC-A, LIN A27874, dated May 85.

RELEASEABLE TO SECURITY ASSISTANCE CUSTOMERS: No

SYNOPSIS: THE AN/FSC-92 PROVIDES RADIO, INTERCOM AND FLIGHT FOLLOWING CAPABILITIES BETWEEN OPERATORS AND PILOTS IN AIRCRAFT.

CCS/AVIONICS

AN/GRC-240, HAVE QUICK II (HQ II) UHF-AM RADIO SET

PROJECT OFFICER: Mr. Laurence Rubel, DSN 992-2991
 COMM 732/532-2991
 FAX: 732/532-6278
 E-Mail: rubel@doim6.monmouth.army.mil

ACQUISITION CATEGORY: III
ACQUISITION PHASE: MS IV Operations/Support

PE & LINE:

DESCRIPTION: The AN/GRC-240 is a vehicle mounted Have Quick (HQ) II radio system providing anti-jam Electronic Counter-Counter Measures (ECCM) UHF-AM voice communications. The radio can operate on single channel "normal" mode or in the frequency hopping ECCM "active" mode. Transmitting output power is selectable at 2, 10 or 30 watts. All US services have HQ capability. The AN/GRC-240 is tunable in 25 KHz steps in the UHF band (225.000 MHz to 399.975 MHz), equating to 7000 UHF channels. The application of the VHF/UHF Antenna Relay MWO permits VHF-AM communications (116.000 MHz to 149.975 MHz, 1360 VHF channels). VHF operation is limited to single channel non-HQ communications. The operator can simultaneously monitor guard frequency 243.000 MHz while operating single channel or HQ mode. Applications requiring improved PLGR satellite reception, PLGR Remote Antenna MWO is available. The UHF frequency hopping ability does not make the radio set secure. Secure VHF and UHF communications is accomplished via the interfacing with COMSEC Equipment KY-57. Mounting hardware and all interconnecting cabling for operation with the KY-57, including power cable for HYP-57, are provided as components of Installation Kit MK-2827/GRC-240. The method by which the radio set frequency hops within the UHF band is determined by a multi-digit code referred to as Word of Day (WOD). In combination with Time of Day (TOD) and a valid Net number, the WOD determines the timing, duration and sequence of frequency changes. The radio set can be programmed with up to a maximum of six WODs, each having a unique date tag. The operator inputting an operational date enables an individual WOD. The radio set will automatically switch to the next daily WOD at 0000Z (if programmed). The radio set permits ground-to-air command and control capability to Army division and corps level aviation brigades and special operation forces. The missions identified for this radio are: Close, rear and deep operations; air assault/security; counter-mobility; command and control; medical evacuation; air attack and offensive air combat. The primary installation platforms are HMMWVs and Command Communication Vehicles.

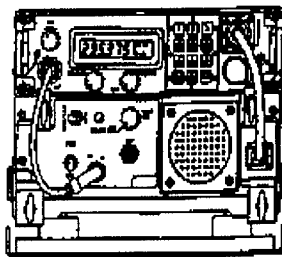

RADIO SET AN/VRC-83(V)3

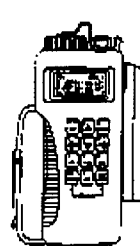

PLGR AN/PSN-11(V)1



COMPONENTS (LRUs) OF THE AN/GRC-240:

ITEM	P/N	CAGE	NSN	PICA
Radio Set AN/VRC-83	7078123-805	37695	5820-01-291-5415	AF
PLGR AN/PSN-11 (V)1	822-0077-002/ 822-0077-103	13499	5825-01-374-6643 /5825-01-395-3513	AF
VHF/UHF Antenna AS-3588/GRC-206	626489-1	37695	5895-01-110-1051	AF
Installation Kit MK-2827/GRC-240	A3210473	20309	5895-01-408-5166	ARMY

RELATED MWOs:

PLGR Remote Antenna	11-5820-1148-13-01	Permits the remote mounting of PLGR AS-4.333/V Antenna
VHF/UHF Antenna Relay	11-5820-1148-13-02	Permits the AN/GRC-240 to operate in the VHF and UHF bands

TRANSPORTATION CHARACTERISTICS / LIMITATIONS: 3.6" L x 2.8" H x 2.5' D; 247 lbs./No Limitations.

HISTORICAL BACKGROUND:

- Mar 82 JCS directs all services to use HQII for Electronic Counter-Countermeasure (ECCM) for UHF band.
- Feb 90 Materiel Change for HQII implementation approved by CG, CECOM.
- Oct 94 Proto-type ground system available for test.
- Jul 96 PM-AEC begins worldwide Total Package Fieldings to Aviation Brigades per Army Aviation Restructuring Initiative.
- Oct 97 Level I (PM-AEC) to Level III (CECOM) management transition.

REQUIREMENTS DOCUMENT: O&O Plan for Army Aviation UHF Radios, Nov 91, CARDS No. 0522P.

TYPE CLASSIFICATION: Standard A approved 1989 by Air Force. NDI to the Army.

RELEASEABLE TO SECURITY ASSISTANCE CUSTOMERS: Per Have Quick II/IIA Security Classification Guide 1 Jun 90 Hanscom Air Force Base, MA. Distribution authorized to Defense and US DoD contractors only (Critical Technology) (28 Feb 95). Other requests shall be referred to SAF/IAD 1010 Air Force Pentagon, Washington, DC 20330-1010.

EVENT SCHEDULE	FISCAL YEAR		97	98	99	00	01	02
	QTR		1 2 3 4	1 2 3 4	1 2 3 4	1 2 3 4	1 2 3 4	1 2 3 4
PM-AEC Completes Fielding			-----4					
Level I (PM-AEC) to Level III (CECOM) Transition			-----4					

SYNOPSIS: HQ II PROVIDES THE ARMY THE ABILITY TO COMMUNICATE SINGLE CHANNEL AND ANTI-JAM WITH ALL US SERVICES AND NATO IN THE UHF-AM BAND, THE COMMUNICATIONS BAND FOR TACTICAL AIR OPERATIONS.

CCS/AVIONICS

TACFIRE
PIP

SINGLE SHELTER DIVARTY



AN/GSG-10, TACFIRE

PROJECT OFFICER: Mr. Charles Bennett,
DSN 992-4241
COMM 732/532-4241

ACQUISITION CATEGORY: IV
ACQUISITION PHASE: MS IV Operations/Support

PE & LINE #: F55750 (CORPS DIVARTY)
F55818 (DIVISION DIVARTY)
F83626 (BATTALION)

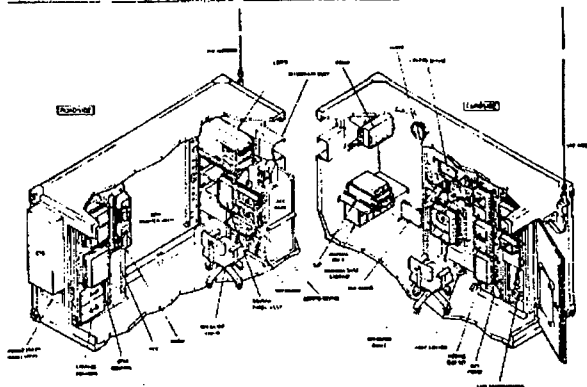

DESCRIPTION: TACFIRE is composed of computers and remote devices linked by digital communications using existing radio and wire communications equipment. TACFIRE automates selected field artillery command and control functions to provide efficient management of fire support resources.

TRANSPORTATION CHARACTERISTICS / LIMITATIONS: Can be transported by regular modes of motor and rail service. Compatible for loading by air in C130, C141, C124, C133, and C5A aircraft.

HISTORICAL BACKGROUND: The last TACFIRE fielding was completed in 1987. Installations of the two major modifications (Upgraded Counterfire Equipment and CP-1822) were completed in 1990. The TACFIRE/MSE interface device is currently being fielded. Replacement of TACFIRE by IFSAS began 2Q94.

REQUIREMENTS DOCUMENT: QMR, Mar 66.

TYPE CLASSIFICATION: Standard approved Oct 78.

RELEASEABLE TO SECURITY ASSISTANCE CUSTOMERS: No

EVENT SCHEDULE	FISCAL YEAR	97	98	99	00	01	02
		QTR	1 2 3 4	1 2 3 4	1 2 3 4	1 2 3 4	1 2 3 4
IFSAS Begin Replacing TACFIRE		---2					

SYNOPSIS: TACFIRE AUTOMATES SELECTED FIELD ARTILLERY COMMAND AND CONTROL FUNCTIONS TO PROVIDE EFFICIENT MANAGEMENT OF FIRE SUPPORT RESOURCES.

CCS/AVIONICS

AN/GYK-29, BATTERY COMPUTER SYSTEM (BCS)

ITEM MANGER: Mr. Robert Saia,
 DSN 992-4080
 COMM 732/532-4080

ACQUISITION CATEGORY: IV
ACQUISITION PHASE:

PE & LINE #: C40499, D31557, D31625, D31693

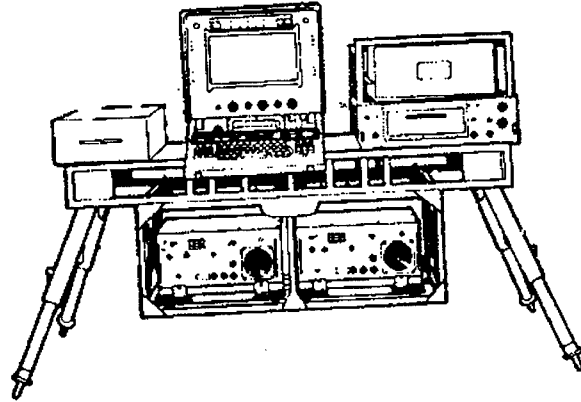

DESCRIPTION: The BCS is a small, on-line, militarized computer system used by the Army's cannon batteries, Multiple Launch Rocket System (MLRS) and LANCE. BCS increases field artillery mission effectiveness by providing two-way digital communications between TACFIRE and the battery, and by enabling accurate and rapid individual piece firing data computations. BCS consists of two main components; the OL-200A Battery Computer Unit (BCU) LIN C40499 and the OD-144(V)1,2,3 Gun Direction Unit (GDU) LINs D31557, D31625, D31693. All active Army and national Guard units have been fielded IFSAS (Interim Fire-Support Automated System AN/GYK-37, Lightweight Computer Unit). The OL200 C40499 is in the process of being type classified obsolete, replaced by LCU, pending the Replacement System LCU assignment of a Standard Lin. Only remaining units using OL200 are FMS Cases Taiwan, Italy. Therefore, the AN/GYK-29 is a Terminal System. All versions of the OD-144 to remain in the field.

TRANSPORTATION CHARACTERISTICS / LIMITATIONS:

HISTORICAL BACKGROUND:

1QFY88 Transition to Systems Management Directorate
 2QFY93 Transition to DMM.

REQUIREMENTS DOCUMENT: ROC, Oct 75.

TYPE CLASSIFICATION: Standard approved Sep 79.

RELEASEABLE TO SECURITY ASSISTANCE CUSTOMERS: Yes

<u>EVENT SCHEDULE</u>	<u>FISCAL YEAR</u>		97	98	998	00	01	02
	<u>QTR</u>		1 2 3 4	1 2 3 4	1 2 3 4	1 2 3 4	1 2 3 4	1 2 3 4
Displacement of OL-200								

SYNOPSIS: BCS IS A SMALL, ON-LINE, MILITARIZED COMPUTER SYSTEM USED BY THE ARMY'S CANNON BATTERIES, MULTIPLE LAUNCH ROCKET SYSTEM AND LANCE.

CCS/AVIONICS

**AN/MYQ-4A, DECENTRALIZED AUTOMATED
SERVICE SUPPORT SYSTEM
(DIVISION/CORPS) DAS-3 (D/C)**

PROJECT OFFICER: Mr. Tyrone Ingram,
DSN 992-0392
COMM 732/532-0392

ACQUISITION CATEGORY: IV
ACQUISITION PHASE: MS IV Operations/Support

PE & LINE #: D 78325

DESCRIPTION: The DAS-3 (D/C) was designed to enhance the DAS-3 (AN/MYQ-4). The systems are similar, but the AN/MYQ-4A has the following distinguishing changes: additional ADP devices, communications interface section, and provisions for a modular collective protection equipment unit. DAS-3 (D/C) is composed of a data processing center housed in a 35 foot, 10-ton semi-trailer van (XM971), an administrative center housed in a 5-ton expansible van, and a dual generator mobile power plant. DAS-3 (D/C) is composed of the following subsystems: ADP Subsystem, AC Power Subsystem, Environmental Subsystem, Communications Subsystem, Remote Subsystem, semi-trailer van unit, expansible van, and power plant. Majority of DAS-3's have been displaced by the DS4 Desktop computer. Only remaining STAMIS supported by the DAS3 is SAAS.



TRANSPORTATION CHARACTERISTICS / LIMITATIONS: System housed in 35 10-ton semi-trailer plus 15-ton van plus mobile generator.

HISTORICAL BACKGROUND:

- Apr 84 Initial Operational Capability.
- Oct 84 Honeywell "BOA" under investigation due to suspected overpricing for spare parts.
- Oct 87 Transition of DAS-3(D/C) from TACMIS to Logistics Support Center, ISEC (renamed ISMA), Ft Monmouth.
- Sep 90 Service and Maintenance contract awarded to ICT.
- Dec 91 Transition of DAS-3 from ISMA to CECOM.
- Mar 93 DAS-3 displacement by DS4 Desktop computer.

REQUIREMENTS DOCUMENT: ROC, Sep 82; ROC revised DAS-3 ROC, 22 Sep 83.

TYPE CLASSIFICATION: Standard approved 27 Aug 84.

RELEASEABLE TO SECURITY ASSISTANCE CUSTOMERS: Yes

SYNOPSIS: DAS-3 (D/C). AN/MYQ-4A ENHANCES THE DAS-3, AN/MYQ-4 BY PROVIDING ADDITIONAL ADP DEVICES.

CCS/AVIONICS

AN/TSW-7A, AIR TRAFFIC CONTROL CENTRAL (ATCC)

PROJECT MANAGER: Mr. Tim Messer,
DSN 992-2729
COMM 732/532-2729

ACQUISITION CATEGORY:
ACQUISITION PHASE:

PE & LINE #: A27624 SSN: P454010

DESCRIPTION: The AN/TSW-7A is a mobile Air Traffic Control facility that can be deployed to tactical air fields for visual control of airborne and ground flight operations. This facility consists of a communications shelter and an ancillary equipment pallet. The communications shelter contains HF/UHF/VHF communications equipment and can accommodate up to three air traffic controllers at one time. Ancillary environmental control and power generating equipment contained on the pallet assembly provides the self-contained capability for operation of this system. Transport of the communications shelter and pallet assembly is accomplished via two each 2-1/2 ton trucks which permits tactical deployment of this facility.

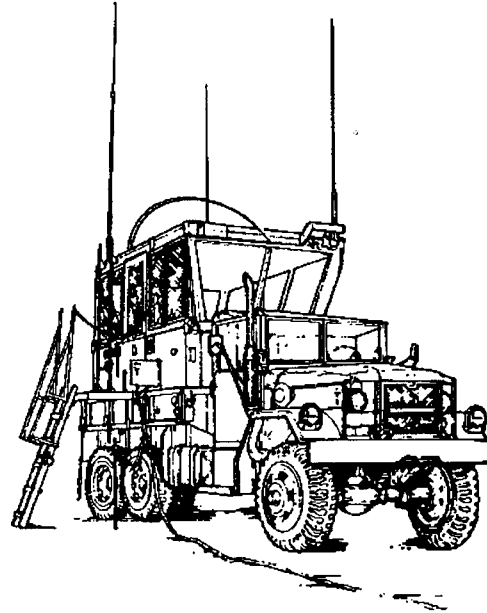

TRANSPORTATION CHARACTERISTICS / LIMITATIONS:

HISTORICAL BACKGROUND:

Sep 79 Production contract award for 22 systems.
Jun 82 First Unit Equipped.
Nov 84 System transition from AVRADA to CECOM.
Jun 86 Six additional systems procured by active Army.
May 88 ECPs approved for communications equipment upgrade.
Dec 89 Initial fielding of upgraded communications equipment.
Dec 95 Transitioned to Level III.

REQUIREMENTS DOCUMENT: Statement of Need prepared by USAISC in Nov 78 to modify an existing Air Force system for Army use.

TYPE CLASSIFICATION: Standard approved Oct 80.

RELEASEABLE TO SECURITY ASSISTANCE CUSTOMERS: No

SYNOPSIS: AN/TSW-7A AIR TRAFFIC CONTROL CENTRAL IS A TRANSPORTABLE FACILITY THAT CAN BE DEPLOYED AT TACTICAL AIR STRIPS FOR AIRBORNE AND GROUND CONTROL OF AIRCRAFT.

CCS/AVIONICS

AN/USM-410, ELECTRONIC QUALITY ASSURANCE TEST EQUIPMENT (EQUATE)

PROJECT OFFICER: Mr. Ralph Moser,
DSN 992-1603
COMM 732/532-1603

ACQUISITION CATEGORY: IV
ACQUISITION PHASE: MS IV Operations/Support

PE & LINE #: T61973. R09696

DESCRIPTION: The AN/USM-410 is a stand-alone, computer controlled Automatic Test system capable of providing diagnostic, analog, digital and hybrid test and repair capability at GS and depot levels to numerous weapons systems (e.g., MI, BFVS, IEW systems, FIREFINDER). AN/USM-410(V)2 is the primary testing resource in the AN/MSM-105(V)1 field, transportable, electronic test and repair system. AN/USM-410(V)4 was developed for use within the Electronic Equipment Test Facility (EETF), providing Aviation Intermediate Maintenance (AVIM) support to the APACHE Attack Helicopter. Non-tactical versions of the AN/USM-410 are used in depot and contractor facilities for production and repair.

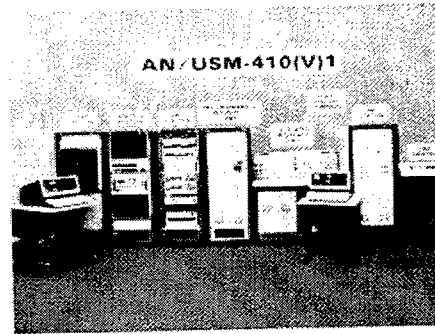

OBJECTIVE ATE SUPPORT SYSTEM

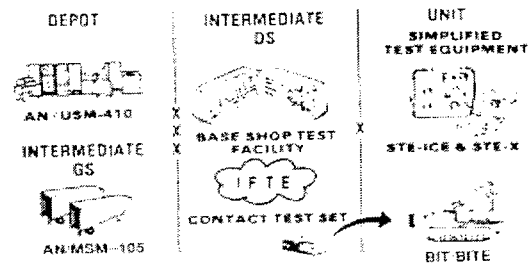

TRANSPORTATION CHARACTERISTICS / LIMITATIONS: C-5
Transportable only; 2 Each 35' SEMITRLRS. W = VAN 8', H = 12', Cu 3,636 23,000 lbs x 2 = 46,000 lbs.

HISTORICAL BACKGROUND:

- Aug 78 Type Classified Limited Procurement authorization for 41 MSM-105s by Special IPR (SIPR).
- Dec 79 AN/MSM-105 designated by DARCOM to fulfill GS/Depot Automatic Test Equipment (ATE) requirement.
- Mar 80 Letter IPR authorized 17 more AN/MSM-105s.
- Jun 83 Initial Operational Capability (USAREUR).
- Jul 91 EETF Type Classified.
- Jul 92 ECP-185 Materiel Release Approved.
- Jan 93 ECP 185 Field Retrofit for EETF Complete.
- Sep 94 Delivery of APACHE AN/USM-410A(V)4 Systems to Foreign Military Sales Complete (Israel, Egypt, Saudia Arabia, UAE and Greece).
- Aug 96 Printer Interface Adapter Available to field.

REQUIREMENTS DOCUMENT: Required Operational Capability, 22 Feb 80.

TYPE CLASSIFICATION: Standard approved May 82 for the AN/USM-410(V)1 and AN/USM-410(V)3; Limited Procurement for the AN/USM-410(V)2, OQ-290(V)1/MSM, and OA-8991/MSM approved May 82. The AN/USM-465A Digital Card Tester Type Classified Standard Jan 93.

RELEASEABLE TO SECURITY ASSISTANCE CUSTOMERS: Yes

EVENT SCHEDULE	FISCAL YEAR															
	97		98		99		00		01		02					
	1	2	3	4	1	2	3	4	1	2	3	4	1	2	3	4
Fielding of overhauled EETF to Ft. Bragg	3															

SYNOPSIS: AN/USM-410 IS A GENERAL PURPOSE FAMILY OF COMPUTER CONTROLLED ATE USED FOR TEST, DIAGNOSIS AND REPAIR OF ELECTRONIC LINE REPLACEABLE UNIT, SHOP REPLACEABLE UNIT, AND PRINTED CIRCUIT BOARDS CONTAINED IN NUMEROUS WEAPONS SYSTEMS.

CCS/AVIONICS

AN/UYQ-43(V)1, TACTICAL COMPUTER
PROCESSOR (TCP) - NDI
AN/UYQ-43(V)2, ANALYST CONSOLE (AC)

MANEUVER CONTROL SYSTEM (MCS)

PROJECT OFFICER: Ms. Judi Smock,
DSN 992-2808
COMM 732/532-2808
FAX DSN 992-6278

ACQUISITION CATEGORY: IV
ACQUISITION PHASE: MS IV Operations/Support

PE & LINE #: SSN: BA-9300

DESCRIPTION: The MCS is a collection of computer equipment which supports operations planning and control at one of the five nodal points (Maneuver Control) of the Army Tactical Command and Control System (ATCCS). It is designed to assist the commander and his staff by providing information on his own forces, enemy forces and the battlefield characteristics. MCS provides this battlefield information by collecting, processing, and displaying data generated within the air/land combat environment. Using the features of this system the commander can improve the timeliness of his decisions and allocation of his resources.

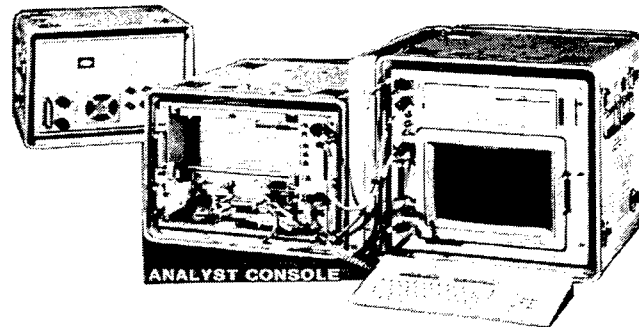
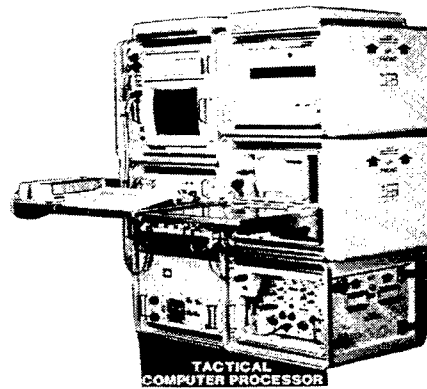

The MCS currently consists of Tactical Computer Processors and Analyst Consoles. The Tactical Computer Processor, AN/UYQ-43(V)1, is a micro-processor based portable system which provides automated assistance to the maneuver commanders. The Analyst Console, AN/UYQ-43(V)2, is a micro-processor based intelligent terminal, connected to the TCP via Local Network, which provides multiple workstations within a nodal configuration. MCS takes advantage of commercial state-of-the-art technology by more readily fielding the commercial hardware NDI.

TRANSPORTATION CHARACTERISTICS / LIMITATIONS: None.

HISTORICAL BACKGROUND:

Jun 87 Awarded NDI contract.
Jul 87 Awarded system engineering and integration contract (MCS); Full production (TCT).
Oct 87 Awarded MCS software contract.
Jul 90 Last unit produced.
Oct 92 Last unit fielded.
Jan 95 Transitioned to Level III Management - DMM.

REQUIREMENTS DOCUMENT: O&O Plan (TCT & NDI) and ROC approved (TCT & NDI) Jul 82; ROC update Jun 88.

TYPE CLASSIFICATION: TCP, AN/UYQ-43(V)1 and AC, AN/UYQ-43(V)2 Type Classified Standard, at IPR, Jun 86.

RELEASEABLE TO SECURITY ASSISTANCE CUSTOMERS: No

SYNOPSIS: MCS IS AN AUTOMATED COMMAND AND CONTROL SYSTEM.

CCS/AVIONICS

CORPS/THEATER ADP SERVICE CENTER I (CTASC-I)

PROJECT MANAGER: Ms. R. LaMacchia
DSN 992-0389
COMM 732/532-0389
FAX 992-4211
COMM 732/532-4211

ACQUISITION CATEGORY: IV
ACQUISITION PHASE: MS IV Operations/Support

PE & LINE #: Z25526, Z62937, Z38296, Z41595, Z50481

DESCRIPTION: The CTASC-I is a mobile Automatic Data Processing (ADP) system supporting Combat Service Support applications at Corps and Theater levels. CTASC I support Standard Army Management Information systems automating personnel, financial and logistics management functions. CTASC-I is composed of a self-contained complex of three semi-trailer vans housing the central processing unit, mass storage units and tape library facilities. The system is also fielded with a maintenance van and two 100 kilowatt generators.

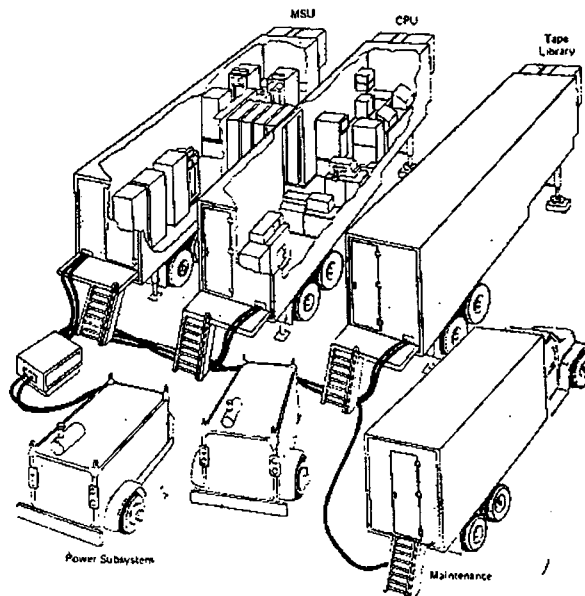

TRANSPORTATION CHARACTERISTICS / LIMITATIONS:

Vehicle Physical Data	Length	Width	Height	Weight (lbs)
CPU Van	466.0"	98.0"	141.0"	(est) 25,850
MSU Van	466.0"	98.0"	141.0"	25,254
Tape Library Van	466.0"	98.0"	141.0"	20,990
M109 Van	263.0"	99.0"	130.0"	22,930
PU 495P/G Engine Generator	188.0"	96.0"	82.0"	10,470

HISTORICAL BACKGROUND:

Feb 80 O&O Approved.
May 80 HQDA Procurement Decision Memorandum.
Nov 82 Contract awarded to IBM for seven systems.
Sep 83 First Unit Equipped.

REQUIREMENTS DOCUMENT: DA directed Procurement.

TYPE CLASSIFICATION: Limited Procurement-Urgent approved Jun 82.

RELEASEABLE TO SECURITY ASSISTANCE CUSTOMERS: No

SYNOPSIS: CTASC-I IS A MOBILE ADP SYSTEM SUPPORTING COMBAT SERVICE SUPPORT APPLICATIONS AT CORPS AND THEATER LEVELS.

CCS/AVIONICS

**CORPS/THEATER ADP SERVICE CENTER-II
(CTASC-II)**

PROJECT OFFICER: Ms. R. LaMacchia,
DSN 992-0389
COMM 732/532-0389
FAX: 992-4211

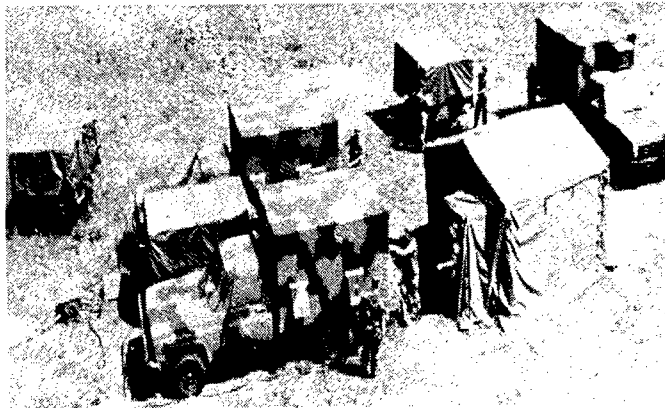

ACQUISITION CATEGORY:
ACQUISITION PHASE:

PE & LINE #: Z81820

DESCRIPTION: The CTASC-II system provides the Army with transportable ADP information systems employed by major subordinate commands at corps and theater levels. CTASC-II Block I provides and processes medical Standard Army Management Information System (STAMIS) software at corps and echelons above corps (EAC). It is organic to the Materiel Management Center (MMC); Theater Medical Materiel Management Center in the Medical Command (MEDCOM); and, the Medical Supply Optical and Maintenance Battalion (MEDSOM). It also exchanges information with other information systems. CTASC-II consists of commercial off-the-shelf computers and communications equipment housed in rigid-wall shelters transported by three Commercial Utility Cargo Vehicles (CUCVs).

TRANSPORTATION CHARACTERISTICS / LIMITATIONS:

HISTORICAL BACKGROUND:

PHASE I - PROOF OF PRINCIPLE:

3QFY87 DA Milestone 0.
2-4QFY87 Prototype Development - mock-up.
1-3QFY88 Prototype Development - sheltered system.
3QFY88 Technical Feasibility Test 1.
4QFY88 Early User Test & Evaluation; DA Major Army Information System Review Council (MAISRC) Milestone I/II.

PHASE II - PRE-PRODUCTION PROVE-OUT:

4Q88-2Q89 Technical Feasibility Test 2.
1QFY90 Pre-Production Prove-Out Testing.
3QFY90 First Unit Equipped - Block I Hardware.
4QFY90 Maintainability Demonstration; TAMMIS Milestone III; Limited Production TAMMIS/ODS.
4QFY91 Exec. Software Acceptance Test; Physical Config. Audit on Tech. Data.
1-2QFY92 SARSS Software Acceptance Test (post-ODS).

REQUIREMENTS DOCUMENT: O&O, 19 Dec 89; ROC, 6 Feb 91.

TYPE CLASSIFICATION: N/A

RELEASEABLE TO SECURITY ASSISTANCE CUSTOMERS: No

SYNOPSIS: CTASC-II SYSTEM PROVIDES THE ARMY WITH TRANSPORTABLE ADP INFORMATION SYSTEMS TO BE EMPLOYED BY MAJOR SUBORDINATE COMMANDS AT CORPS AND THEATER LEVELS.

CCS/AVIONICS

FORWARD ENTRY DEVICE (FED)

PROJECT OFFICER: Joan McDonald,
 DSN 992-0391
 COMM 732/532-0391

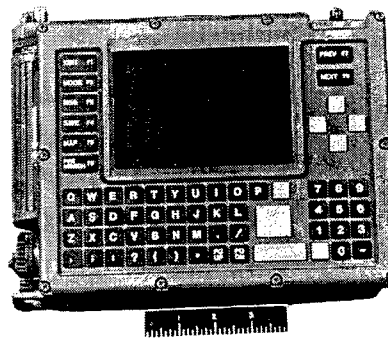

ACQUISITION CATEGORY: IV
ACQUISITION PHASE: MS III Production/Deployment

PE & LINE #: 5213

DESCRIPTION: The Forward Entry Device (FED) is a battlefield automation system with specific application in fire support within the Army Tactical Command and Control System (ATCCS). The FED is a remote data-entry device that provides digital message processing and data storage in the conduct and planning of fire support operations at maneuver platoon, company, battalion and brigade levels. The FED uses the Simplified Handheld Terminal Unit (SHTU), a CHS1 item, and special fire support software applications. The FED has evolved into a mature system through three software versions: Forward Observer/Fire Support Team (FO/FIST), Forward Observer Command and Control (FOCC) and Meteorological Survey (MSR). FED FUE was in Jun 92. Fielding to all Light Infantry Divisions has been completed, however, due to size and weight considerations the FED was not fielded to the Forward Observer and the Aerial Observer. The availability of a lightweight FED (LFED) to meet this requirement is being explored. FED fielding is complete. A requirement to comply with MIL-STD-188-220 requires additional software development and an upgrade to the current FED configuration. This FED Upgrade Program is managed by PM FATDS, PEO C3S.

TRANSPORTATION CHARACTERISTICS / LIMITATIONS: Dimensions are 10.75" x 7.75" x 2.5". Weight: 6.84 lbs. System is transportable within the High Mobility Multi-Purpose Wheeled Vehicle (HMMWV), Fire Support Team Vehicle (FISTV), SUSV and by foot soldiers in its carrying case.

HISTORICAL BACKGROUND:

- Mar 91 Milestone III approval; Production buy awarded.
- Jun 92 FUE FED with FO/FIST software.
- Aug 92 FOCC IOT&E; Full Materiel Release Approval.
- May 93 FOCC Full Materiel Release.
- Jun 93 FOCC FUE.
- Mar 94 MSR Materiel Release; MSR FUE.
- Jul 94 Materiel Change Approval.
- Oct 96 Transfer of FED Upgrade to PM FATDS.

REQUIREMENTS DOCUMENT: Quantitative Materiel Requirement - TACFIRE, 1966; Army Tactical Command and Control Systems Annex (H/W), 1986; Draft Annex E to ATCCS Fire Support ORD for AFATDS, 1993.

TYPE CLASSIFICATION: Standard, Mar 91.

RELEASEABLE TO SECURITY ASSISTANCE CUSTOMERS: No

<u>EVENT SCHEDULE</u>	FISCAL YEAR	97	98	99	00	01	02
		1 2 3 4	1 2 3 4	1 2 3 4	1 2 3 4	1 2 3 4	1 2 3 4
Maintenance Concept Change to DS/GS Level			3				

SYNOPSIS: FED WILL BE EMPLOYED TO COMPOSE, EDIT, TRANSMIT, RECEIVE, STORE AND DISPLAY MESSAGES USED IN THE EXECUTION AND PLANNING OF FIRE SUPPORT OPERATIONS AT MANEUVER PLATOON, COMPANY, BATTALION AND BRIGADE LEVELS.

CCS/AVIONICS

LARGE-SCALE TACTICAL DOCUMENT COPIER

PROJECT MANAGER: Mr. David E. Mount,
DSN 992-0390
COMM 732/532-0390

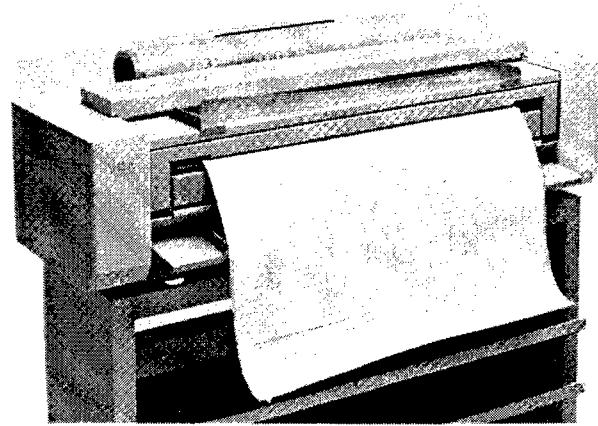

ACQUISITION CATEGORY: IV
ACQUISITION PHASE: MS IV Operations/Support

PE & LINE #:

DESCRIPTION: The Large-Scale Tactical Document Copier program was initiated as a result of direction from the Battle Command Integration Program General Officer Steering Committee to field a non-developmental item (NDI) copier capable of reproducing large documents up to 36 inches in width. This copier reproduces large documents such as battle maps and mission overlays which are required to coordinate battlefield activities. A ruggedized case is provided to transport the copier and associated support items for field deployment. This item has been approved for Common Table of Allowance (CTA) distribution.

TRANSPORTATION CHARACTERISTICS / LIMITATIONS: 55 x 19 x 13.5 (in.), Weight = 180 lbs.

HISTORICAL BACKGROUND:

- Jan 88 III Corps identified a need for a tactical large-scale copier.
- Apr 88 CACDA tasked SIGCEN to identify NDI copier to meet mission needs.
- Aug 90 General Officer Steering Committee directs expeditious completion of copier testing and fielding activities.
- Mar 91 CECOM TAC completes testing on Xerox copier.
- Feb 92 Program management responsibilities transferred to SMD to direct copier acquisition and fielding activities.
- Jun 92 Contracts awarded for copier and associated support components.

REQUIREMENTS DOCUMENT: General Office Steering Committee Directs 2510 copier for fielding Aug 90.

TYPE CLASSIFICATION:

RELEASEABLE TO SECURITY ASSISTANCE CUSTOMERS: Yes

SYNOPSIS: THE LARGE-SCALE TACTICAL DOCUMENT COPIER IS A COMMERCIAL COPIER CAPABLE OF BEING DEPLOYED TO REPRODUCE BATTLE MAPS AND MISSION OVERLAYS.

CCS/AVIONICS

LIGHTWEIGHT TACTICAL FIRE DIRECTION SYSTEM (LTACFIRE)

PROJECT OFFICER: Mr. Robert Saia,
DSN 992-4126
COMM 732/532-4126

ACQUISITION CATEGORY: IV
ACQUISITION PHASE: MS IV Operations/Support

PE & LINE #: 5212

DESCRIPTION: The LTACFIRE is designed to provide a light-weight transportable and user friendly automated fire support system, for use within the light infantry divisions (LID). A prototype system was fielded to the 9th Infantry Division at Ft Lewis, WA in 1985 under the experimental test bed concept. Fielding to the seven LIDs began in Sep 90 and was completed Jan 92.

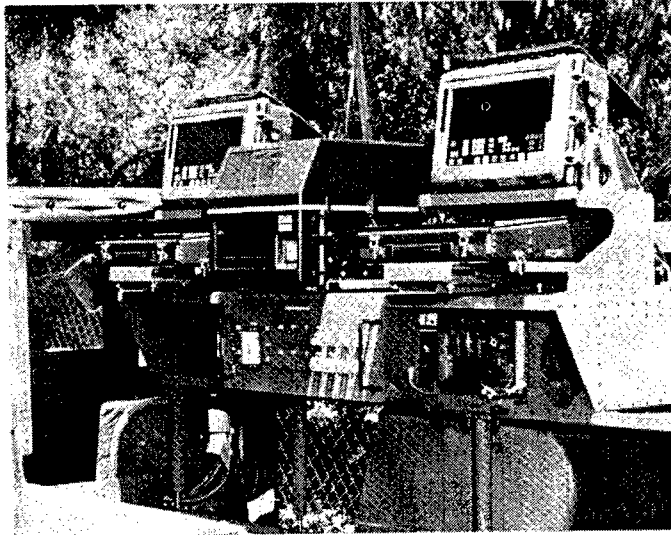

LTACFIRE provides the Division Artillery (DIVARTY) of the light division a fully automated means to plan, control and execute fires of field artillery and mortars. Computer terminals are located at artillery battalion, DIVARTY, and Division Fire Support Element and Brigade FSE nodes. Communications between nodes and with a variety of interfacing devices is accomplished via communications means already available to the light infantry division. LTACFIRE functions are used to automate the manual techniques that were used in the light infantry's artillery battalions and DIVARTY. These include non-nuclear fire planning; tactical fire control; ammunition and fire unit data; meteorological data, artillery target intelligence and support/geometry information.

TRANSPORTATION CHARACTERISTICS / LIMITATIONS: Capable of Worldwide Transport by Air, Ship, Rail, Ground and Military Transport to Include LVAD and EAT.

HISTORICAL BACKGROUND:

Oct 82 Quick Reaction Program, QRP-2-32.
Dec 87 Congress mandated obligation of FY86 OPA funds for procurement of LTACFIRE for the Light Divisions;
Mar 88 Letter contract awarded to Litton Data Systems.
Sep 90 FUE.
Feb 92 Last unit equipped.

REQUIREMENTS DOCUMENT: QRP-2-32, Dec 87, HQDA directed that FY86 funds be used to procure LTACFIRE for seven light divisions.

TYPE CLASSIFICATION: Type Classification requirement waived.

RELEASEABLE TO SECURITY ASSISTANCE CUSTOMERS: Yes

SYNOPSIS: LTACFIRE IS DESIGNED TO PROVIDE A LIGHTWEIGHT TRANSPORTABLE AND USER FRIENDLY AUTOMATED FIRE SUPPORT SYSTEM FOR USE WITHIN THE LIGHT INFANTRY DIVISION.

CCS/AVIONICS

TACTICAL ARMY COMBAT SERVICE SUPPORT COMPUTER SYSTEM (TACCS)

PROJECT LEADER Mr. David E. Mount,
DSN 992-0390
COMM 732/532-0390

ACQUISITION CATEGORY: IV
ACQUISITION PHASE: MS IV Operations/Support

PE & LINE #: C72396, C72626, C08565, C72876

DESCRIPTION: The TACCS is an off-the-shelf ruggedized, two-man transportable computer and software system to be used on the battlefield at Company level and above. The basic TACCS will include a central processing unit, random access mass storage, printer, visual display, keyboard entry device, communications interface, and the capability to both archive the mass storage and electronically transfer data between work stations. The system is operated by military personnel of various grades and ADP skill levels and by functional people with no computer programmer training. It provides support to personnel, supply, maintenance, medical, ammunition, and transportation functional areas. TACCS will interface with DAS-3, TCS, and TCT.

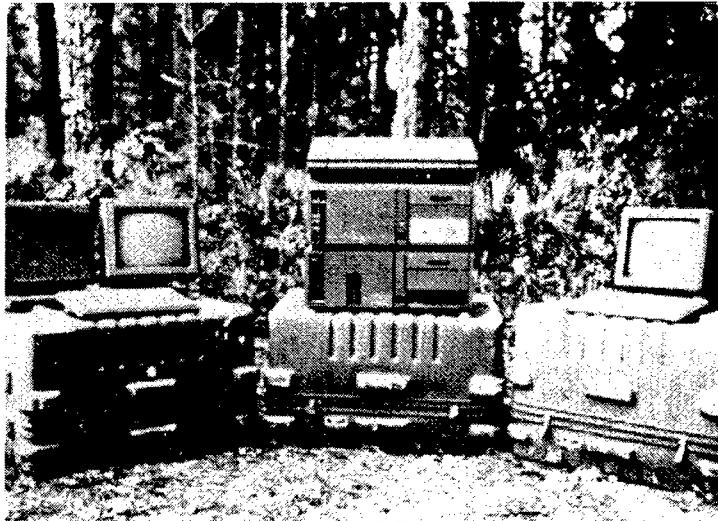

TRANSPORTATION CHARACTERISTICS / LIMITATIONS: H 22" x W 36" x D 28"; 130 lbs.

HISTORICAL BACKGROUND:

Sep 84 Production contract award.
May 85 First Unit Equipped; First Article Test began.
Jul 90 ECP approved by DA to upgrade the system processor and software (TACCS-E).
Jan 91 Completed delivery of basic TACCS Box under existing contract.
Mar 91 Full Materiel Release granted to TACCS Program; Fielding of TACCS-E retrofit began.
Oct 92 TACCS program transitioned from PM TACMIS to CECOM.
Jun 94 TACCS Repair Program Transitioned from contractor support to Depot Organic Program at Tobyhanna Army Depot.

REQUIREMENTS DOCUMENT: USA TRADOC ACN ROC, 82.

TYPE CLASSIFICATION: Limited Production, with full production decision by MAISRC approved Oct 86. Standard approved Nov 90.

RELEASEABLE TO SECURITY ASSISTANCE CUSTOMERS: No

SYNOPSIS: TACCS IS A TRANSPORTABLE COMPUTER AND SOFTWARE SYSTEM PROVIDING SUPPORT TO THE PERSONNEL, SUPPLY, MAINTENANCE, MEDICAL, AMMUNITION AND TRANSPORTATION FUNCTIONAL AREAS. TACCS-E IS A MODIFIED/UPDATED VERSION OF THE TACCS WHICH UTILIZES THE INTEL 80386 PROCESSOR AND BTOS 2 FOR AN OPERATING SYSTEM.

CCS/AVIONICS

**INTERFACE UNIT, AUTOMATIC DATA
PROCESSING, CA-67A/U
TACTICAL TERMINAL ADAPTER (TTA)**

PROJECT MANAGER: Mr. A. White,
DSN 992-4334
COMM 732/532-4334

ACQUISITION CATEGORY: IV
ACQUISITION PHASE: MS III Production/Deployment

PE & LINE #:

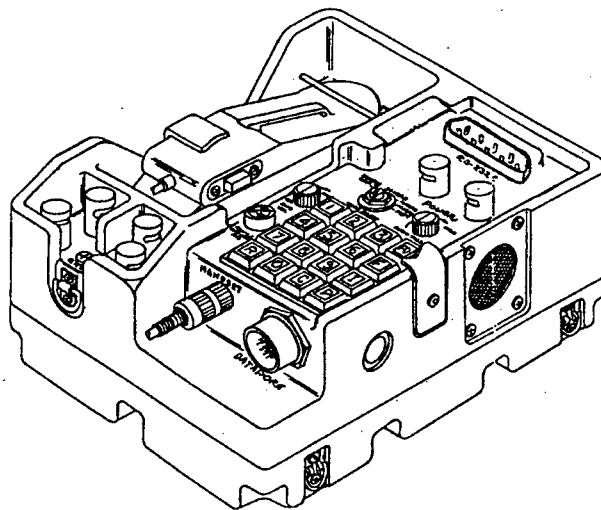

DESCRIPTION: The TTA is an interface device which enables any Personal Computer (PC) with the DOS operating system and an RS-232C port to transmit/receive data over the Mobile Subscriber Equipment (MSE) circuit-switch (voice) or packet switching (data) networks. The TTA emulates the functionality of a Digital Non-Secure Voice Terminal (DNVT) in order to transmit/receive data over the MSE circuit switch network. The ability of the TTA to transmit/receive data over the MSE packet network is achieved through the incorporation of X.25 communications protocol software. The TTA is available in both a ruggedized & non-ruggedized version and is authorized for Army-wide distribution via Common Table of Allowance (CTA) 50-909.

TRANSPORTATION CHARACTERISTICS / LIMITATIONS: None.

HISTORICAL BACKGROUND:

- Jun 92 Sole Source Procurement of 1100 TTAs from Star Dynamic Corporation.
- Jan 93 SMD assumes Program Management from PM, TACMIS.
- Feb 93 SMD issues user survey for identification of TTA requirements.
- Apr 93 HQDA approves TTA for inclusion into Common Table of Allowances (CTA) 50-909.
- May 94 Contract awarded for ruggedized TTA.
- Mar 95 FAT completed.
- Apr 95 FA test report accepted.
- Jul 95 Production deliveries begin.
- Apr 96 Test specification (A3209302) Revised.
- Apr 97 Test specification (A3209302 REVA) Revised to Rev B.

REQUIREMENTS DOCUMENT: N/A

TYPE CLASSIFICATION: N/A

RELEASEABLE TO SECURITY ASSISTANCE CUSTOMERS: No

SYNOPSIS: THE TTA PROVIDES THE CAPABILITY TO INTERFACE PERSONAL COMPUTERS TO THE MOBILE SUBSCRIBER EQUIPMENT IN ORDER TO TRANSMIT/RECEIVE DATA.

CCSLA

**THIS SECTION IS
NOT AVAILABLE**

COMMUNICATIONS

COMMUNICATIONS DIRECTORATE

AB-1309/TRC MAST

PROJECT OFFICER: Mr. Philip Sapienza,
DSN 992-8319
COMM 732/532-8319
FAX: DSN 987-1757
COMM 732/427-0757
E-Mail: sapienza@doim6.monmouth.army.mil

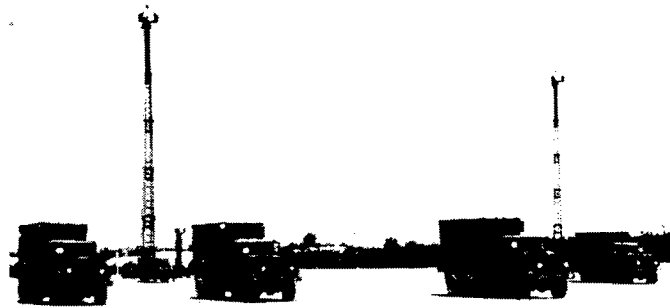

ACQUISITION CATEGORY: IV
ACQUISITION PHASE: IV Operations/Support

PE & LINE #:

DESCRIPTION: The AB-1309/TRC Mast is a highly mobile, 120-foot collapsible tower which can support up to 3 AS-1425 antennas. The mast telescopes down to a height of 23 feet and is lowered to the horizontal position for transit. It is mounted on a tandem axle trailer which also carries two MEP-003A ten kilowatt diesel generators. AB-1309/TRC and ancillary hardware are towed by a 5-ton truck that transports a Digital Group Multiplexer (DGM) Shelter Assembly. This mobile configuration unit is eight feet wide, eight feet high and 30 feet long. AB-1309/TRC has aircraft transportability certification.

TRANSPORTATION CHARACTERISTICS / LIMITATIONS:

HISTORICAL BACKGROUND:

- 1981 Testing (DT/OT) of Digital Transmission Assemblages identified the need for: rapid antenna deployment and recovery; a height of 34 meters; C-130 transportability; and Modular Collective Protection Equipment (MCPE).
- o AB-1309 was designed to satisfy these requirements.
- 1986 The user community determined that the AB-1309 was not suitable as the primary antenna mast system for DGM assemblages and was replaced by the DAMP.
- o The AB-1309 was designated an ancillary antenna system to be deployed with each signal battalion at echelons above corps.

REQUIREMENTS DOCUMENT: MSG, HQDA, SAIS-PPS, 2019172 Aug 87, subject: AB-1309 requirement.

TYPE CLASSIFICATION: Limited Production, Urgent.

RELEASEABLE TO SECURITY ASSISTANCE CUSTOMERS: Yes

SYNOPSIS: AB-1309/TRC MAST IS A HIGHLY MOBILE, COLLAPSIBLE TOWER WHICH CAN SUPPORT UP TO THREE AS-1425 ANTENNAS AND PROVIDES DGM SYSTEM POWER AND ANCILLARY ITEM TRANSPORT.

COMMUNICATIONS DIRECTORATE

**AB-1386/U, QUICK ERECT ANTENNA MAST
(QEAM)**

PROJECT OFFICER: Mr. Mario Ambrosio,
DSN 987-4097
COMM 732/427-4097

ACQUISITION CATEGORY: III
ACQUISITION PHASE: MS III Production/Deployment

PE & LINE #:

DESCRIPTION: The QEAM is designed to accommodate the AS-3166/GRC, AS-4292, AS-4225, A30045068 VHF antennas and a wide range of other antennas in other frequency bands. The system is man transportable weighing less than 100 lbs. The largest item weighs less than 42 lbs. The QEAM can be erected in winds up to 25 MPH, operate in winds of 60 MPH, and survive in winds of 80 MPH; in field mount configuration or installed on HMMWV, M-577, and M1068.

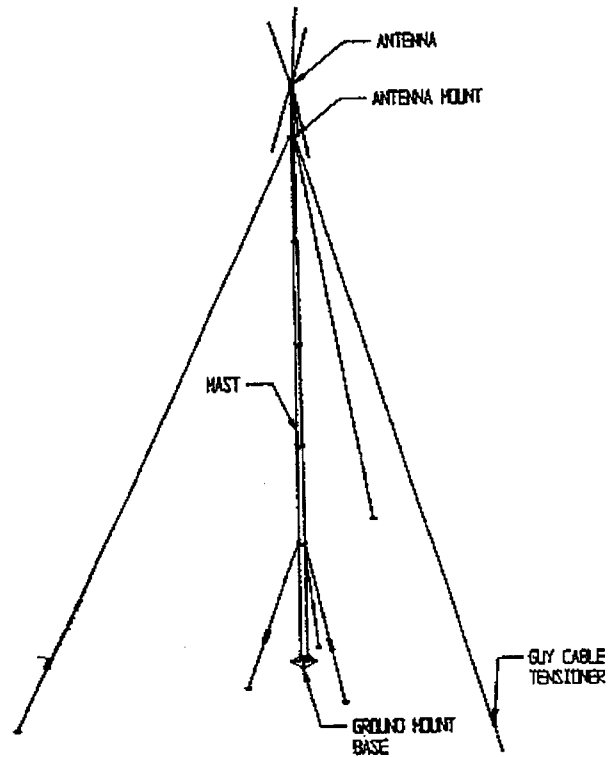

TRANSPORTATION CHARACTERISTICS / LIMITATIONS: N/A.

HISTORICAL BACKGROUND:

- Apr 92 Acquisition Plan Approved.
- Jun 92 Solicitation Released.
- Feb 93 Contract Awarded.
- Mar 93 First Option Awarded.

REQUIREMENTS DOCUMENT: Operational & Organizational Plan, Jun 87; Required Operational Capability, Aug 89.

TYPE CLASSIFICATION: Generic, May 92; Standard, Feb 98.

RELEASEABLE TO SECURITY ASSISTANCE CUSTOMERS: Yes

EVENT SCHEDULE	FISCAL YEAR	97	98	99	00	01	02
		1 2 3 4	1 2 3 4	1 2 3 4	1 2 3 4	1 2 3 4	1 2 3 4
Limited User Test (LUT)	QTR	4	1				

SYNOPSIS: THE QEAM IS DESIGNED TO ACCOMMODATE THE AS-3166/GRC, AS-4292, AS-4225, A30045068 VHF ANTENNAS AND A WIDE RANGE OF OTHER ANTENNAS IN OTHER FREQUENCY BANDS.

COMMUNICATIONS DIRECTORATE

AN/GRC-193, IMPROVED HIGH FREQUENCY RADIO SET

PROJECT OFFICER: Ms. Gloria Richardson,
DSN 992-9196
COMM 732/532-9196
FAX 992-4971
EMAIL richardson@doim6.monmouth.army.mil

ACQUISITION CATEGORY: IV
ACQUISITION PHASE: MS IV Operations/Support

PE & LINE #: H35404 SSN: BB1600

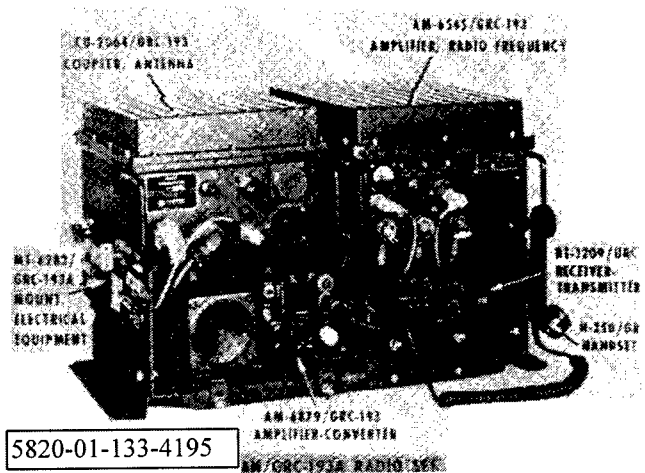

DESCRIPTION: The AN/GRC-193 vehicular radio set provides secure voice and data C3 capability for tactical units in compatible AM, SSB, CW, and DATA modes at medium-to-high power (100-400 watts). AN/GRC-193 was produced in three configurations: AN/GRC-193; AN/GRC-193A; and AN/GRC-193B. The radios are secured with the KY-65 (voice) or KG-84 (data) and feature automatic antenna tuning. Frequency range is 2-30 megahertz providing 280,000 channels in 100 hertz increments. Other features include build-in-test capabilities, reflect power protection, and remote operation by wireline up to two kilometers. The radio interfaces with the AN/VIC-1 Vehicle Intercom System and is compatible with the AN/UGC-74 at 300 words per minute operated for voice and MOS 31K for teletype. AN/GRC-193B has all the above features with the addition of the short term anti-jam (STAJ) frequency hopping capability.

TRANSPORTATION CHARACTERISTICS / LIMITATIONS: No Limitations; Approx. 175 lbs to include installation kit, 16 x 24 x 16" (L x W x H).

HISTORICAL BACKGROUND:

Jul 81 USA Program Objective Memorandum established.
Dec 81 Non-Developmental Item decision approved.
May 85 Follow-On Evaluation.
Sep 85 FY85 Production contract award.
Nov 85 Official transfer of program responsibility to PM, SINCGARS.
Dec 86 First Unit Equipped.
Aug 94 Fielding of STAJ AN/GRC-193 B completed.

REQUIREMENTS DOCUMENT: ROC DA approved 30 Nov 81.

TYPE CLASSIFICATION: Standard A approved Jun 83; BOIP approved 22 Oct 86.

RELEASEABLE TO SECURITY ASSISTANCE CUSTOMERS: Yes - AN/GRC-193(A)
No - AN/GRC-193(B)

SYNOPSIS: AN/GRC-193 IS A MEDIUM TO HIGH POWER VEHICULAR RADIO SET TO PROVIDE SECURE VOICE (KY-65) DATA C3 IN THE COMPATIBLE AM, SSB, CW, AND DATA MODES WITH AUTOMATIC ANTENNA TUNING AND 280,000 CHANNELS IN 100 HERTZ INCREMENTS.

COMMUNICATIONS DIRECTORATE

AN/GRC-213, IMPROVED HIGH FREQUENCY RADIO SET

PROJECT OFFICER: Ms. Gloria Richardson,
DSN 992-9196
COMM 732/532-9196
FAX 992-4971
EMAIL richardson@doim6.monmouth.army.mil

ACQUISITION CATEGORY: IV
ACQUISITION PHASE: MS IV Operations/Support

PE & LINE #: R30895 SSN: BB1802

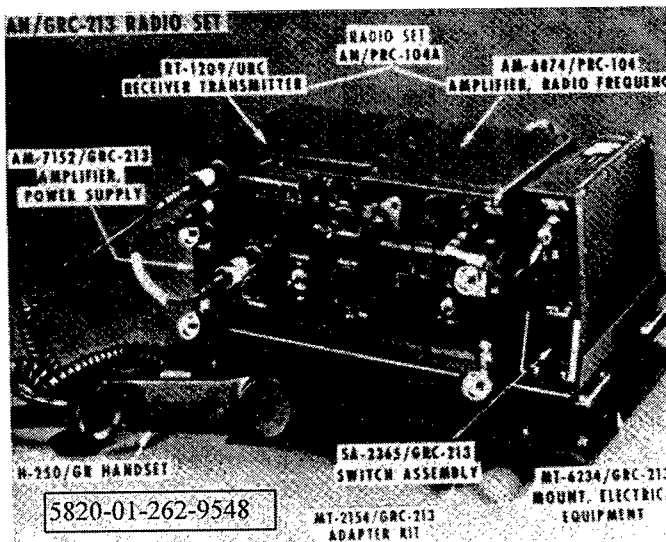

DESCRIPTION: The AN/GRC-213, Improved High Frequency Radio Set (IHFR) provides a vehicular mounting capability as well as rapid removal for manpack only operations. It is a Low Power (20 watt) Manpack/Vehicular radio set composed of an AN/PRC-104A Manpack radio with all the necessary ancillary items. AN/GRC-213 will provide secure voice and data communications when used with the KY-65 voice, KY-84 data or future COMSEC equipments. in the SSB, compatible AM, CW and DATA modes. AN/GRC-213 is user operated and about as complex to use as the current family of VHF/FM radios. The radio features include automatic antenna tuning, 2-30 megahertz frequency range with 280,000 channels in 100 hertz increments, built in test features and receive squelch. The radio interfaces with the vehicular intercom system AN/VIC-1 and provides FM retransmission capability. All IHFR radios will provide secure voice communications with KY-65 or future COMSEC equipment.

TRANSPORTATION CHARACTERISTICS / LIMITATIONS: No Limitations; Approx. 140 lbs to include installation kit.
10 x 22 x 15" (L x W x H).

HISTORICAL BACKGROUND:

Jul 81 USA Program Objective Memorandum established.
Dec 81 Non-Developmental Item decision approved.
May 85 Follow-On-Evaluation.
Nov 85 Official transfer of program responsibility to PM, SINCGARS.
Dec 86 First Unit Equipped.
Aug 94 Fielding of STAJ AN/GRC-213A completed.

REQUIREMENTS DOCUMENT: ROC DA approved. 30 Nov 81.

TYPE CLASSIFICATION: BOIP approved, 22 Oct 86, Standard A.

RELEASEABLE TO SECURITY ASSISTANCE CUSTOMERS: Yes - AN/GRC-213()
No - AN/GRC-213(A)

SYNOPSIS: AN/GRC-213. IHFR SET IS A LOW POWER MANPACK/VEHICULAR MOUNTED RADIO SET TO PROVIDE SECURE VOICE (KY-65) AND DATA C3 (KY-84). IT HAS AUTOMATIC ANTENNA TUNING, 280,000 CHANNELS IN 100 HERTZ INCREMENTS AND RETRANSMISSION CAPABILITY.

COMMUNICATIONS DIRECTORATE

AN/GRC-222, RADIO SET/AMOW

PROJECT OFFICER: Peter Kozak,
DSN 987-7248
COMM 732/427-7248

ACQUISITION CATEGORY: III
ACQUISITION PHASE: MS III/IV Prod/Deploy/Op/Spt

PE & LINE #:

DESCRIPTION: The AN/GRC-222, Radio Set provides the Army with High Capacity Line-of-Sight (HI-CAP-LOS) and Short Range Wide Band Radio (SRWBR) capabilities while operating in the 4.4 to 5.0 gigahertz frequency range. These radios are deployed in the AN/TRC-175(), Radio Terminal Assemblage located in the switching node at the "Bottom-of-the-Hill" and AN/TRC-138A/B/C, Repeater Assemblage located in the radio park at the "Top-of-the-Hill". The HI-CAP-LOS radio mode accommodates one group in the ATACS or TRI-TAC hierarchies of up to 144 channels at a group rate of 1024, 1152, 1536, 2048, 2304, 4096, or 4608 kilobits per second. The SRWBR mode of operation accommodates groups in the TRI-TAC hierarchy of up to 576 channels at master group rates of 9.36 or 18.72 megabits per second. The SRWBR is used to provide the link between a multichannel switching node and transmission facilities or "Top-of-the-Hill". The Amplitude Modulated Orderwire (AMOW) radio modification provides significant operational enhancement by facilitating link acquisition and set up

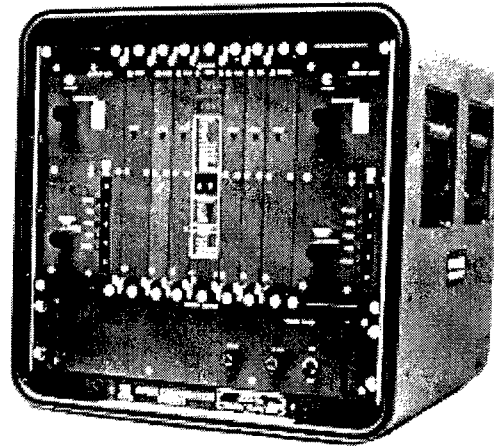

TRANSPORTATION CHARACTERISTICS / LIMITATIONS: See AN/TRC-175() and AN/TRC-138A/B/C ASSE.

HISTORICAL BACKGROUND:

Mar 85 Coordinated decision with Signal Center to replace AN/GRC-144(V)3 radio with NDI AN/GRC-222 radio.
Sep 86 Contract awarded to Aydin Corporation for 733 radios.
Dec 88 FAT completed.
Apr 90 Final Logistics Support Concept (FLSC).
Aug 92 Peculiar Support Equipment (PSE) award.
Jan 94 Baseline Radio established for Retrofit/Field Swapout Program.
Jul 94 Level III Drawings (Aperture Cards) delivered.
Mar 95 Peculiar Support Equipment (PSE) delivered.
Dec95 Production deliveries completed.

REQUIREMENTS DOCUMENT: HQDA Letter Requirement for DGM Assemblages. 19 Mar 76.

TYPE CLASSIFICATION: IPR, Jul 81, STD A for end items AN/TRC-138A/175.

RELEASEABLE TO SECURITY ASSISTANCE CUSTOMERS: Yes

SYNOPSIS: AN/GRC-222. OPERATING IN THE 4.4 TO 5.0 GIGAHERTZ FREQUENCY RANGE PROVIDES THE ARMY WITH HI-CAP-LOS AND SRWBR CAPABILITIES AT ECHELONS ABOVE CORPS (EAC).

COMMUNICATIONS DIRECTORATE

**AN/PRC-104, IMPROVED HIGH FREQUENCY
RADIO SET**

PROJECT OFFICER: Ms. Gloria Richardson,
DSN 992-9196
COMM 732/544-9196
FAX 992-4971
EMAIL richardson@doim6.monmouth.army.mil

ACQUISITION CATEGORY: IV
ACQUISITION PHASE: MS IV Operations/Support

PE & LINE #: R55200 SSN: BG1801

DESCRIPTION: The low power (20 watt) Improved High Frequency Radio Set (IHFR), AN/PRC-104 provides single sideband command and control communications for tactical units in the compatible AM, SSB, CW and Data modes. AN/PRC-104 is user operated and is about as complex to use as the current family of VHF FM radios. The radio utilizes either a non-rechargeable BA-5590 Lithium battery or a rechargeable BB-590 NICAD battery. The radio features automatic antenna tuning, operates in the 2-30 MHz frequency range, maximum bandwidth 3 KHz, 280,000 channels in 100 Hz increments, and built-in test features. All IHFR radios will provide secure voice communications with KY-65 or future COMSEC equipment. AN/PRC-104B has all above features with addition of STAJ frequency hopping capability.

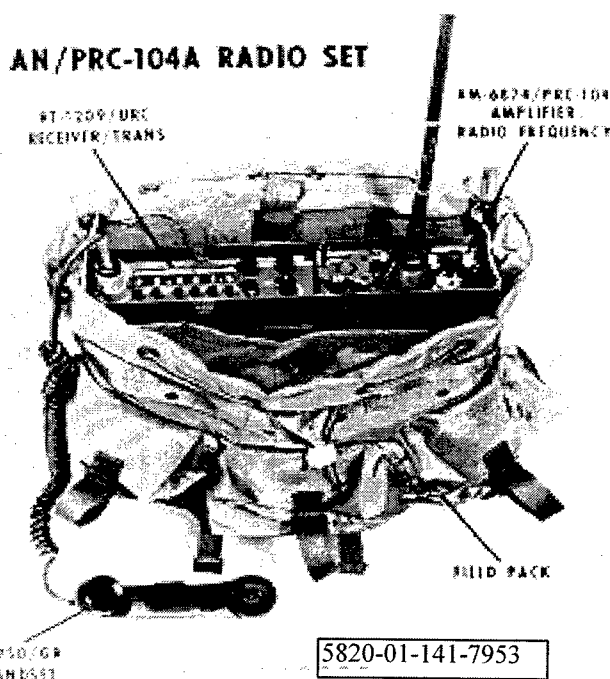

TRANSPORTATION CHARACTERISTICS / LIMITATIONS: Approx. 28 lbs, 8 x 13 x 3" (L x W x H).

HISTORICAL BACKGROUND:

- Jul 81 USA Program Objective Memorandum established.
- Dec 81 Non-Developmental Item decision approved.
- Mar 82 BOIP/QQPRI approved.
- Jun 85 Follow-On Evaluation.
- Nov 85 Official transfer of program responsibility to PM, SINCGARS; Materiel Release.
- Mar 87 First Unit Equipped.
- Aug 94 Fielding of STAJ AN/PRC-104B completed.

REQUIREMENTS DOCUMENT: ROC, 30 Nov 81.

TYPE CLASSIFICATION: Standard A approved Jun 83.

RELEASEABLE TO SECURITY ASSISTANCE CUSTOMERS: Yes - AN/PRC-104(A)
No - AN/PRC-104(B)

SYNOPSIS: AN/PRC-104 IS A LOW POWER, IMPROVED HIGH FREQUENCY RADIO SET TO PROVIDE SINGLE SIDEBAND COMMAND AND CONTROL COMMUNICATIONS FOR TACTICAL UNITS IN THE COMPATIBLE AM, SSB, CW AND DATA MODES.

COMMUNICATIONS DIRECTORATE

AN/PRC-126, RADIO SET

ITEM LEADER: Ms. Rosemary Hicks,
DSN 992-9189
COMM 732/532-9189
FAX: DSN 992-4971
EMAIL: hicks@doim6.monmouth.army.mil

ACQUISITION CATEGORY: IV
ACQUISITION PHASE: MS IV Operations/Support

PE & LINE #: R55336

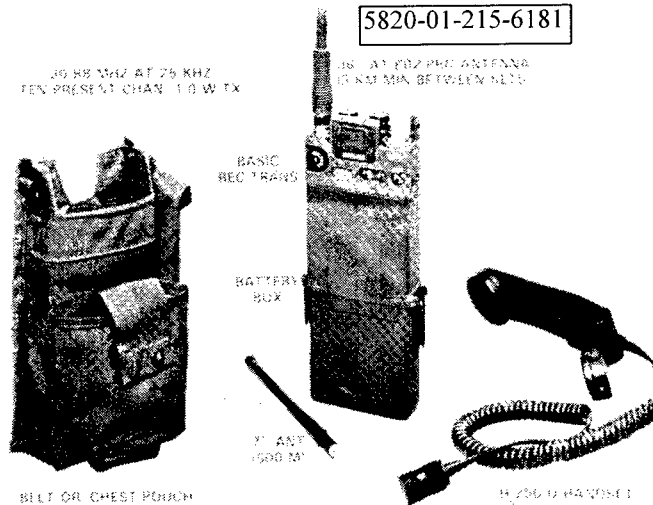

DESCRIPTION: The AN/PRC-126 is a short range, handheld tactical radio for use primarily at the squad/platoon level. AN/PRC-126 is a lightweight, militarized transceiver providing two-way, voice-communications. The radio covers the frequency range of 30-87.975 megahertz. Its nominal range for reliable communications over rolling, slightly wooded terrain is 3,000 meters. The radio is capable of interoperating with the AN/VRC-12, AN/PRC-77, and SINGGARS families of radios in the fixed frequency mode. AN/PRC-126 enables small unit leaders to adequately control the activities of subordinate elements in carrying out the unit's mission. AN/PRC-126 is required for the Infantry, Rangers and Special Forces.

TRANSPORTATION CHARACTERISTICS / LIMITATIONS: Size (including battery case) 10" L x 3.8" W x 1.5" D;
Weight (including battery) 2.6 lbs.

HISTORICAL BACKGROUND:

May 85 VCSA decision to take NDI approach to replace the AN/PRC-68.
Jul 86 First Production contract awarded to Magnavox.
Sep 89 Phase I fielding completed.
May 93 Phase II fielding completed.

REQUIREMENTS DOCUMENT: ROC, 3 Oct 85; Card Reference Number 0851.

TYPE CLASSIFICATION: Standard A approved 30 Jul 86.

RELEASEABLE TO SECURITY ASSISTANCE CUSTOMERS: Yes

SYNOPSIS: AN/PRC-126 RADIO SET IS A HAND-HELD RECEIVER TRANSMITTER THAT PROVIDES SHORT-RANGE, GROUND-TO-GROUND VOICE COMMUNICATION IN THE 30 MEGAHERTZ TO 80 MEGAHERTZ BAND.

COMMUNICATIONS DIRECTORATE

AN/PRC-127, RADIO SET

PROJECT OFFICER: Carol Magee,
DSN 992-9187
COMM 732/532-9187
FAX: 992-4909
E-Mail: mageec@doim6.monmouth.army.mil

ACQUISITION CATEGORY: IV
ACQUISITION PHASE: III Production & Deployment

PE & LINE #: N17818



DESCRIPTION: The AN/PRC-127 is a short range, hand-held, non-militarized radio for use primarily by support troops. AN/PRC-127 is a small, lightweight, Very High Frequency (VHF) radio capable of providing two-way voice communications at ranges up to three kilometers. It covers at minimum, the frequency range of 136-160 megahertz. AN/PRC-127 will be employed at the lowest echelon of command to control squad and teamsized elements of Combat Service and Combat Service Support units whose mission requires the use of a radio for control of supply areas, construction areas, convoys, base defense and dismounted rear battle operations. Radio set includes Receiver/Transmitter, Antenna, Speaker/Microphone, Nickel Cadmium Battery Packs, Battery Charger, Non-Rechargeable Battery Cell Holder, and nylon case holders.

TRANSPORTATION CHARACTERISTICS / LIMITATIONS: Size: 2.5" x 1.5" x 7.8"; Weight: 25 oz.

HISTORICAL BACKGROUND:

May 85 VCSA decision on NDI approach to replace AN/PRC-68 radio.
Feb 88 Sole Source Contract awarded to Bendix/King.
Nov 92 Bendix/King repair contract for RT-1594/PRC-127.
Apr 96 Buy contract amended for additional quantity of 7,640 for RT 1594.
Aug 96 New contract awarded DAAB07-96-D-C015 for 10,500 for new AN/PRC-127A.
Aug 96 Same as above, except the new radio channel spacing will be smaller; +-2.5 kHz versus old radio +-5 KHz.

REQUIREMENTS DOCUMENT: ROC, 7 Jan 87.

TYPE CLASSIFICATION: Standard approved 29 Jan 88.

RELEASEABLE TO SECURITY ASSISTANCE CUSTOMERS: Yes

SYNOPSIS: AN/PRC-127 NON-HARDENED SMALL UNIT RADIO IS A COMPACT, LIGHTWEIGHT, HAND-HELD TRANSCIVER. IT IS CAPABLE OF PROVIDING SMALL UNIT LEVEL COMMUNICATIONS OVER DIVERSE TERRAIN UNDER A WIDE RANGE OF CLIMATIC CONDITIONS.

COMMUNICATIONS DIRECTORATE

5820-01-145-4943

**AN/PSC-3 and AN/VSC-7, SINGLE CHANNEL
ULTRA HIGH FREQUENCY (UHF)
SATELLITE COMMUNICATIONS TACTICAL
TERMINALS**

PRODUCT MANAGER: Mr. Gordon Lyon,
DSN 992-9167
COMM 732/532-9167
FAX: DSN 992-4909
COMM 732/532-4909
E-Mail: lyong@doim6.monmouth.army.mil

PROJECT LEADER: Mr. George Grob,
DSN 992-9159
COMM 732/532-9159

ACQUISITION CATEGORY: ACAT IV
ACQUISITION PHASE: IV

PE & LINE #: SSN: K77200

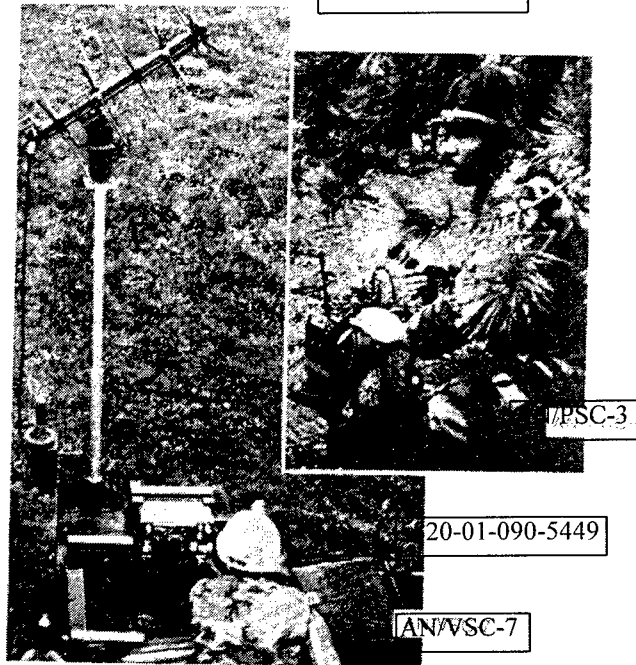

DESCRIPTION: The AN/PSC-3 is a man-portable Satellite Communications Tactical Terminal. The AN/VSC-7 is a vehicular mounted version of the AN/PSC-3 with the following additional hardware: Applique, Shock Mount/Rack Mount Trays, High Gain Antenna, Antenna Mast, and Hand Set. These terminals provide a satellite communications capability primarily for Special Operations Forces and Army Ranger Units for use in forward areas or behind enemy lines. AN/PSC-3 is a rugged, lightweight portable device capable of being paged while in motion, providing positive visual and audible indications to the operator. It weighs less than 35 pounds including the RT-1402A/G, the medium gain antenna, low gain (whip) antenna, the handset H-250/U, and battery box with batteries. AN/VSC-7 will serve as the Net Control Station for up to 15 AN/PSC-3 Terminals.

TRANSPORTATION CHARACTERISTICS / LIMITATIONS:

PSC-3: L-24", H-10", W-16", Wt 21 pounds.

HISTORICAL BACKGROUND:

May 79 DEVA IPR.
Sep 81 First Production contract award.
Aug 86 Final Production contract award.
Dec 90 New power amplifier approved by PM, SATCOM; All fieldings halted due to Operation Desert Shield.
Apr 91 Last unit AN/PSC-3 delivered.
Apr 94 Transitioned to Level III Management - DMM.

REQUIREMENTS DOCUMENT: TACSATCOM QMR approved Nov 71.

TYPE CLASSIFICATION: Standard approved Aug 86.

RELEASEABLE TO SECURITY ASSISTANCE CUSTOMERS: Yes* (*May be some restrictions on who can get these, also scheduling air time will be a problem).

SYNOPSIS: AN/PSC-3 AND AN/VSC-7 ARE SINGLE CHANNEL UHF SATELLITE COMMUNICATIONS TACTICAL TERMINALS.

COMMUNICATIONS DIRECTORATE

**AN/TRC-170(V)2 and (V)3, TROPOSCATTER
RADIO TERMINAL (TROPO)**

PROJECT LEADER: Mr. Nick Petouses,
DSN 992-8326
COMM 732/532-8326

ACQUISITION CATEGORY: III
ACQUISITION PHASE: MS III Production/Deployment

PE & LINE #:

DESCRIPTION: The AN/TRC-170(V)2 & AN/TRC-170(V)3 are air and ground transportable troposcatter radio terminals. The terminals provide secure digital long haul trunking between major nodes of ACUS communication networks and interface with other ACUS systems such as assemblages of Digital Group Multiplexer (DGM) equipment or various switching facilities. The terminals may be used in stand-alone applications as transmission links not associated with switching facilities. The terminals provide for the transmission and reception of digital voice and digital data over a nominal 150 mile path for the (V)2 radio and a nominal 100 mile path for the (V)3 radio by means of troposcatter. Line-of-Sight propagation may also be used in the 4.4 gigahertz to 5.0 gigahertz frequency range. The terminals provide for trunk group communications at switch selectable bit rates from 128 to 4608 kilobits per second in addition to orderwire traffic.

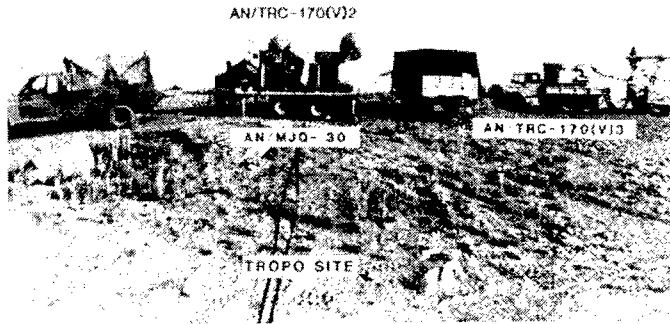

COMPOSED OF:

- (V)2 M923 5-ton truck carries S-280 shelter towing M1061E1 5-ton trailer with two 30 kilowatt power units.
M35A2 2-1/2-ton truck carries antennas on Low Profile Pallet towing M105A2 1/2-ton trailer with HFR radio.
- (V)3 M1097 (Heavy HMMWV) carries S-250 shelter towing M116A2 3/4 ton trailer with Quick Reaction Antenna (QRA).
M1097 carries 10KW power unit and HF radio towing PU-753/M 10KW power unit.

USED WITH: ACUS systems.

REPLACES: AN/TRC-132, 132A, 112, 121 and 80.

TRANSPORTATION CHARACTERISTICS / LIMITATIONS: None.

HISTORICAL BACKGROUND: Air Force is the lead service for this program.

- Jun 76 Air Force Research and Development contract.
- Aug 80 DT&E/IOT&E.
- Dec 86 Completed FOT&E.
- May 87 Competitive contract awarded.
- Sep 87 First Unit Equipped.
- Aug 92 Fifth Materiel Release.
- Mar 93 Start (V)3 Retrofit Program.
- Mar 97 Complete (V)3 Retrofit Program.

REQUIREMENTS DOCUMENT: JOR SM 86-75, 10 Feb 75.

TYPE CLASSIFICATION: Limited production approved Jan 83; Standard approved 27 May 85.

RELEASEABLE TO SECURITY ASSISTANCE CUSTOMERS: No

SYNOPSIS: TROPO PROVIDES SECURE TRANSMISSION AND RECEPTION OF TACTICAL MULTI-CHANNEL DIGITAL VOICE AND DATA BY MEANS OF TROPO MODE OF PROPAGATION IN THE 4.4 TO 5.0 GIGAHERTZ FREQUENCY BAND.

COMMUNICATIONS DIRECTORATE

5895-01-284-8305

AN/TSC-85B

**AN/TSC-85B and AN/TSC-93B, TACTICAL
SATELLITE COMMUNICATIONS TERMINALS**

PROJECT LEADER: Mr. Edward Harris,
DSN 992-8791
COMM 732/532-8791

PRODUCT MANAGER: Mr. Dennis Coviello,
DSN 992-8089
COMM 732/532-8089

ACQUISITION CATEGORY:
ACQUISITION PHASE:

PE & LINE #: SSN: BB8417

DESCRIPTION: The AN/TSC-85B and AN/TSC-93B are Super High Frequency (SHF) systems which provides reliable multichannel capacity satellite communications with an anti-jam capability. Both terminals operate with an eight foot diameter antenna through the Defense Satellite Communications System (DSCS) satellite network. AN/TSC-93B provides a capacity of 24 channels that can operate in a point to point mode or as a non-nodal terminal in a nodal network. AN/TSC-85B provides a capacity of 48 channels that can also operate in a point to point mode or as a nodal terminal in a nodal network. The Baseband Improvement Modification (BIM) is a directed program change by Joint Chiefs of Staff (JCS) to the Army Ground Mobile Forces (GMF) SHF program. This change increases and improves satellite efficiency and interoperability modes between Army (AN/TSC-85B, AN/TSC-93B) and Air Force (AN/TSC-100A, AN/TSC-94A) terminals. The terminals use spacecraft resources more efficiently while improving network management and control.



AN/TSC-85B terminal with Quick React Antenna (OE-361)



TRANSPORTATION CHARACTERISTICS / LIMITATIONS:

HISTORICAL BACKGROUND:

Jun 76 LRIP contract awarded to RCA Corporation (AN/TSC-85, AN/TSC-93).
Feb 79 Full Scale Production approved.
Sep 79 Production contract awarded to Harris Corporation.
Apr-Nov 85 First production unit delivered; First Article Test; First Unit Equipped; Initial Operational Capability.
Sep 86 BIM awarded (AN/TSC-85B, AN/TSC-93B).
Jul 92 BIM Complete.
May 94 HQDA Decision not to field AJCM.
Aug 94 Transition to Level III Management.

REQUIREMENTS DOCUMENT: TACSATCOM Qualitative Materiel Requirement approved 12 Nov 71.

TYPE CLASSIFICATION: LRIP terminals approved Apr 77; Standard approved Jul 85.

RELEASEABLE TO SECURITY ASSISTANCE CUSTOMERS: Yes* (*May be some restrictions on who can get these, also scheduling air time will be a problem).

SYNOPSIS: AN/TSC-85B AND AN/TSC-93B ARE SHF SYSTEM WHICH PROVIDES MULTICHANNEL CAPACITY SATELLITE COMMUNICATION WITH AN ANTI-JAM CAPABILITY.

COMMUNICATIONS DIRECTORATE

AN/TSC-94A and AN/TSC-100A, MULTICHANNEL SUPER HIGH FREQUENCY SATELLITE COMMUNICATIONS TERMINALS

PROJECT LEADER: Mr. Edward Harris,
DSN 992-8791
COMM 732/532-8791

PRODUCT MANAGER: Mr. Dennis Coviello,
DSN 992-8089
COMM 732/532-8089

ACQUISITION CATEGORY:
ACQUISITION PHASE:

PE & LINE #: 739017Q2 (Air Force Equipment)



DESCRIPTION: The AN/TSC-94A and AN/TSC-100A, Ground Mobile Forces (GMF) multichannel Super High Frequency (SHF) Satellite Communications Terminals are shelter mounted. The terminals are full duplex trunking, and are utilized by the Air Force to provide subscriber voice channels or TRI-TAC groups. Both terminals provide a high order of component commonality, redundancy, and Built-In-Test-Equipment (BITE). In a stressed environment, both have the capability to operate with an Anti-Jam Control Modem (AJCM). AN/TSC-100A is capable of operating simultaneously with up to four AN/TSC-94A nodal terminals in a mesh or hub spoke mode. Both terminals use an 8 foot antenna or a 20 foot Quick Reaction Satellite Antenna (QRSAs). Both terminals interoperate with the GMF AN/TSC-85B and AN/TSC-93B terminals.

TRANSPORTATION CHARACTERISTICS / LIMITATIONS: AN/TSC-94A transported by two M-35 (two and one-half ton) trucks. AN/TSC-100A transported by two M-923 trucks.

HISTORICAL BACKGROUND:

Apr 82 Production contract award.
Feb 86 First Article Test completed; First production deliveries.
May 86 Air Force Follow-on Operational Test and Evaluation (FOT&E) completed; Deliveries stopped due to FOT&E findings.
Oct 86 Deliveries resumed, problem corrected.
Dec 89 Last terminal delivered.
Sep 91 Engineering Change Proposal (ECP) awarded to General Electric Corporation (GE) to fabricate AJCM installation kits.
Jan 95 Transitioned to Level III Management - DMM.

REQUIREMENTS DOCUMENT:

TYPE CLASSIFICATION: Not applicable as the Air Force is the only user.

RELEASEABLE TO SECURITY ASSISTANCE CUSTOMERS: Yes* (*May be some restrictions on who can get these, also scheduling air time will be a problem).

SYNOPSIS: AN/TSC-94A AND AN/TSC-100A ARE MULTICHANNEL SHF SATELLITE TERMINALS USED BY THE AIR FORCE TO PROVIDE SUBSCRIBER VOICE CHANNELS OR TRI-TAC GROUPS.

COMMUNICATIONS DIRECTORATE

AN/TSC-128, LONG RANGE SURVEILLANCE UNIT - BASE RADIO STATION (LRSU-BRS)

PROJECT MANAGER: Ms. Gloria Richardson,
DSN 992-9196
COMM 732/532-9196
FAX 992-4971
EMAIL richardson@doim6.monmouth.army.mil

ACQUISITION CATEGORY:

ACQUISITION PHASE:

PE & LINE #:

DESCRIPTION: The AN/TSC-128 Long Range Surveillance Unit Base Radio Station (LRSU-BRS) is a communications system providing LRSU's the ability to pass Human Intelligence (HUMINT) and Command and Control (C2) information between LRSU teams and their headquarters. Current documentation on the system is being updated/corrected to allow the system to be designated as a major item for accounting purposes. However, the system will only be procurable as an Installation Kit (IK) from CECOM along with additional equipment (shelters, radios, teletypes) already in the possession of the gaining units.

TRANSPORTATION CHARACTERISTICS / LIMITATIONS:

HISTORICAL BACKGROUND:

Aug 89 Start of interim program under SOF Control.
Oct 89 HQDA authorizes AN/TSC-128 interim use.
Mar 90 First prototype installed at Fort Benning, GA.
Jan 91 First production kits fielded to USAREUR.
Apr 91 Program control transferred to RDEC.
Apr 93 Program control transferred to SMD.
Jun 94 Program control transferred to DMM.

REQUIREMENTS DOCUMENT: Limited Procurement - Urgent.

TYPE CLASSIFICATION: Limited Procurement - Approved Jan 90 HQDA.

RELEASEABLE TO SECURITY ASSISTANCE CUSTOMERS: No

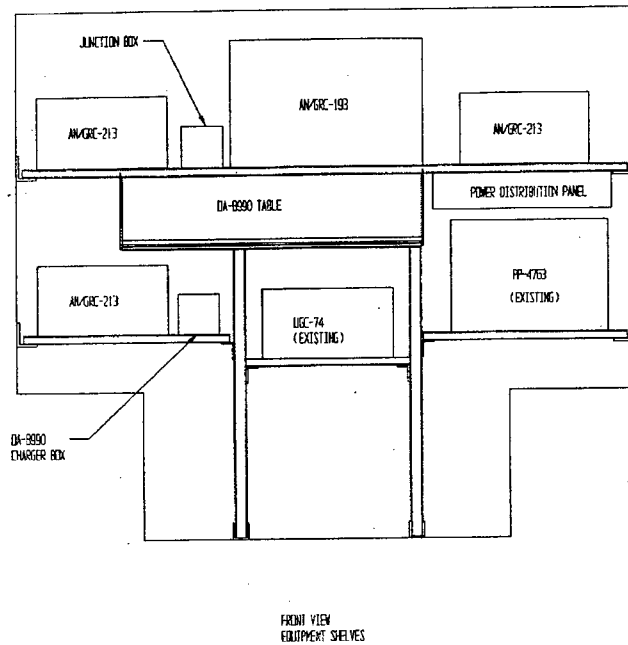

SYNOPSIS: AN/TSC-128 IS A COMMUNICATIONS SYSTEM WITH THE ABILITY TO PASS HUMAN INTELLIGENCE AND COMMAND AND CONTROL INFORMATION BETWEEN LRSU TEAMS AND HQ.

COMMUNICATIONS DIRECTORATE

AN/TTC-41(V), CENTRAL OFFICE, TELEPHONE, AUTOMATIC

ITEM MANAGER: Michael Grieb,
DSN 987-4583
COMM 732/427-4583
FAX: DSN 992-9135
COMM 732/532-9135
E-Mail: alsman@doim6.monmouth.army.mil

ACQUISITION CATEGORY: N/A
ACQUISITION PHASE: IV

PE & LINE #: 738017-P1

DESCRIPTION: The AN/TTC-41(V) is an air or vehicular transportable system used to provide rapid automatic switching to tactical units in area-type communications system. It provides cordless service to 2-wire common battery signaling (CBS) lines; 20 hertz ringdown (RD) lines or trunks; common battery dial pulse or dual tone multi-frequency (DTMF) lines; 4-wire tone signaling trunks; 4-wire DTMF confirmation, tone burst, and converter trunks; 4-wire single frequency signaling AUTOVON access; automatic tandem, and five levels of precedence and preemption. Depending on the number of SB-3614(V)A/TT Switchboards in the AN/TTC-41(V) shelter, the system can provide from 30 to 120 lines of service. AN/TTC-41(V) replaces the AN/MTC-3, AN/MTC-7, and AN/TTC-23. Materiel Change program (MC 1-90-07-0015) provides an arctic heater to the AN/TTC-41(V) shelter for those systems operating in arctic weather.

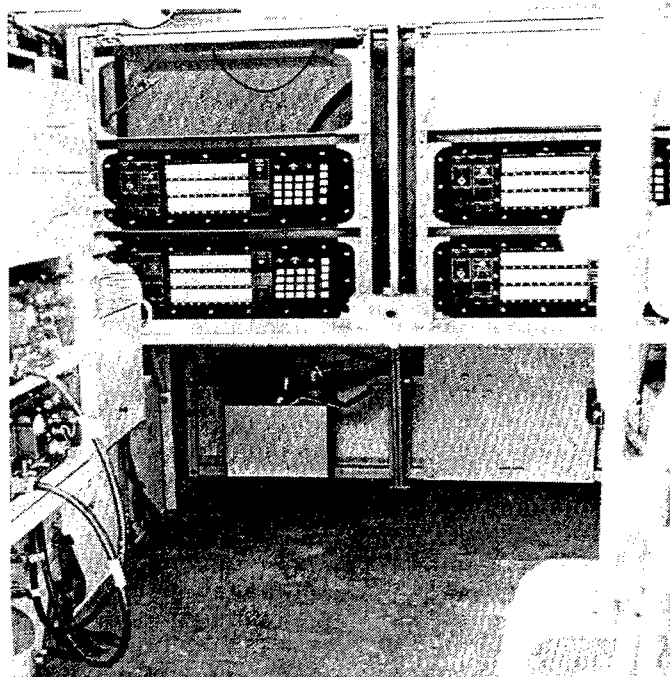

TRANSPORTATION CHARACTERISTICS / LIMITATIONS:

HISTORICAL BACKGROUND:

Sep 76	Production contract awarded to SAAD.
Jul 77	Prototype Testing.
Jun 90	Arctic heater Materiel Change approved by CCB/SLRB.
Aug 90	Arctic heater Materiel Change applied to units fielded in arctic weather.
May 90-Sep 93	Systems being fielded under the Battlefield Communication Review Program (BCR).

REQUIREMENTS DOCUMENT: Qualitative Materiel Requirement approved Feb 72, amended Jan 73.

TYPE CLASSIFICATION: AN/TTC-41(V)1 to (V)4, Standard, Jul 77. AN/TTC-41(V)5 to (V)7, Limited Production, Mar 78.

RELEASEABLE TO SECURITY ASSISTANCE CUSTOMERS: Yes

SYNOPSIS: AN/TTC-41(V) PROVIDES RAPID AUTOMATIC SWITCHING TO TACTICAL UNITS IN AN AREA-TYPE COMMUNICATION SYSTEM.

COMMUNICATIONS DIRECTORATE

AN/UGC-144, COMMUNICATIONS TERMINAL

PROJECT OFFICER: Mr. Joseph Donato,
DSN 987-3864
COMM 732/427-3864

ACQUISITION CATEGORY: IV
ACQUISITION PHASE: MS IV Operations/Support

PE & LINE #: 1X428010.A1905028



DESCRIPTION: The AN/UGC-144 is a formal record traffic communications terminal capable of storing, editing, displaying, transmitting, receiving and printing record traffic in the R (General Service) and Y (Intelligence) communities at all echelons of a tactical communications system. The equipment is user owned and operated.

TRANSPORTATION CHARACTERISTICS / LIMITATIONS: Two Man Lift. 69 lbs (32 KG)

HISTORICAL BACKGROUND:

Jun 90 1st fielding.
Jul 90 Materiel Release.
Oct 90 VECP Auxiliary Storage Cassette approved.
Apr 92 Final Logistics Support Concept (FLSC) on contract.
May 93 Transitioned to Level II Management.
Oct 93 Software Version 2.2 Released.
Dec 93 Organic depot level maintenance began at Tobyhanna Army Depot.

REQUIREMENTS DOCUMENT: NDI ROC approved by HQDA Jul 86.

TYPE CLASSIFICATION: Standard approved Oct 86.

RELEASEABLE TO SECURITY ASSISTANCE CUSTOMERS: Yes

SYNOPSIS: AN/UGC-144 COMMUNICATIONS TERMINAL IS A MODERN COMMUNICATIONS TERMINAL EMPLOYING SOLID STATE ELECTRONICS AND MICROPROCESSOR CONTROL OF FUNCTIONS.

COMMUNICATIONS DIRECTORATE

5895-01-252-7359

AN/USC-43(V)2, ADVANCED NARROWBAND
DIGITAL VOICE TERMINAL (ANDVT)
TACTICAL TERMINAL

ITEM MANGER: Ms. Debra Telsner,
DSN 992-8327
COMM 732/532-8327
FAX: DSN 992-1757
COMM 732/532-1757
E-Mail: telsner@doim6.monmouth.army.mil

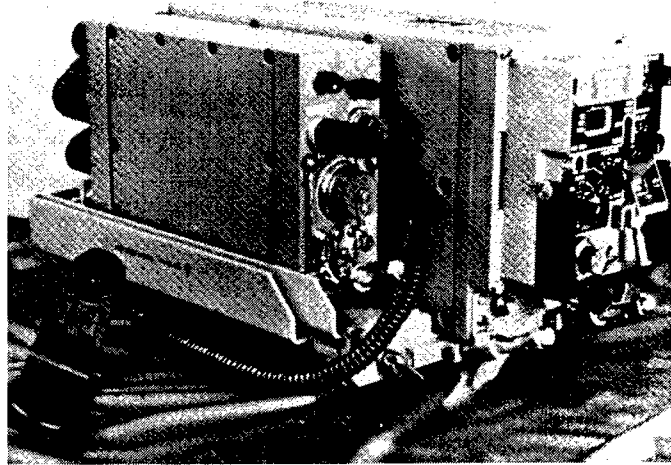

ACQUISITION CATEGORY:
ACQUISITION PHASE:

PE & LINE #: 5211.605042

DESCRIPTION: The ANDVT provides a narrowband, secure voice capability for tactical and strategic echelons. It is used in a variety of locations ranging from fixed plant to vehicles. ANDVT Tactical Terminal (TACTERM) provides fixed and mobile forces with the capability of secure voice or data transmission via High Frequency (HF), Very High Frequency (VHF), Ultra High Frequency (UHF) radio satellite systems, wireline, or Net Radio Interfaces (NRI). ANDVT is a TRI-TAC item of equipment and meets the interoperability requirements of STANAGs 4197, 4198 and 4291. ANDVT TACTERM in its standard configuration consists of two equipments: A Basic Terminal Unit, CV-3591, (P)/U, and a COMSEC Module, KYV-5/TSEC, hereafter referred to as the BTU and CM respectively. A third equipment, the Interface Unit, J-3953 (includes cables and field mount) is used only when the ANDVT TACTERM directly replaces a KY-65 or for wireline applications. In other configurations, the BTU/CM assembly will directly replace a KY-75.

TRANSPORTATION CHARACTERISTICS / LIMITATIONS:

HISTORICAL BACKGROUND:

Dec 85 Letter contract award.
Feb 87 MIPR to Navy - 1987 funds.
Apr 88 FAT completed.
May 90 Materiel Fielding Plan (MFP).
Aug 90 Interim conditional/fielding release approved by AMC.
Jul 92 HQDA authorization for units to retain units.

REQUIREMENTS DOCUMENT: JOR SM-869-76 validated, Oct 76.

TYPE CLASSIFICATION: Correspondence IPR, 17 Oct 85; Standard.

RELEASEABLE TO SECURITY ASSISTANCE CUSTOMERS: No

SYNOPSIS: ANDVT TACTICAL TERMINAL WILL PROVIDE FIXED AND MOBILE FORCES WITH THE CAPABILITY OF SECURE VOICE OR DATA TRANSMISSION VIA HIGH FREQUENCY, VERY HIGH FREQUENCY (VHF) ULTRA HIGH FREQUENCY (UHF) RADIO SATELLITE SYSTEMS, WIRELINE, OR NET RADIO INTERFACES.

COMMUNICATIONS DIRECTORATE

5815-01-187-7844

**AN/UXC-7, LIGHTWEIGHT DIGITAL
FACSIMILE (LDF)**

ITEM MANAGER: Mr. Ralph Handy,
DSN 992-8331
COMM 732/532-8331
FAX: DSN 992-5079
COMM 732/532-5079
E-Mail: handy@doim6.monmouth.army.mil

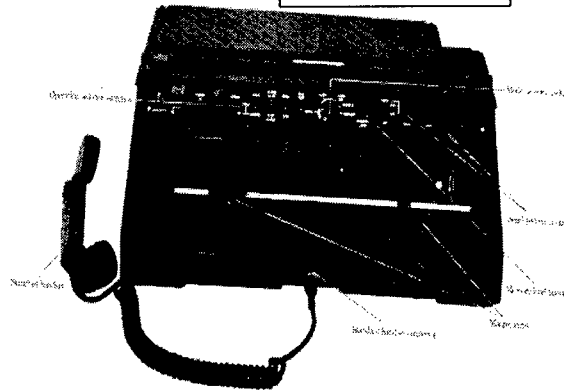

ACQUISITION CATEGORY:
ACQUISITION PHASE:

PE & LINE #: L67964

DESCRIPTION: The AN/UXC-7 is a non-developmental program and provides facsimile graphic/narrative traffic capability over digital switched voice and data networks, combat net radios, and supplements the Single Subscriber Terminal and/ or communications centers at maneuver elements from battalion through echelons above corps. LDF is capable of operating over voice bandwidth channels having error rates up to 1 in 1000. It is also capable of operating over tactical cable/wire systems through direct wireline interface and tactical switching systems. LDF is capable of operating both with and without approved COMSEC appliques in all of the above configurations. NATO interoperability conforming to STANAG 5000 is provided. The 55 pound LDF is capable of transmitting/receiving handwritten/typewritten copy, sketches, and overlays up to 8 1/2" by 14" in black and white format. The required on-the-air time is less than 15 seconds at 16 kilobytes per second for an average 8 1/2" by 11" typewritten page.

TRANSPORTATION CHARACTERISTICS / LIMITATIONS:

HISTORICAL BACKGROUND:

Mar 85 Protest resolved; Production contract awarded to Magnavox Advanced Products and System Company.
May 86 First Article Test completed/secure lighting modification implemented.
Jul 89 Army deliveries completed.
Jun 91 Contract Modification for out-of-warranty depot level repair.
Jul 91 Full Materiel Release.
Jun 92 Management Transition to Level III Management for PM MSCS.

REQUIREMENTS DOCUMENT: Joint Operational Requirement MJCS-26-84, 17 Feb 84.

TYPE CLASSIFICATION: Standard approved 12 Sep 84.

RELEASEABLE TO SECURITY ASSISTANCE CUSTOMERS: Yes

SYNOPSIS: AN/UXC-7 IS A TERMINAL FOR TRANSMISSION/RECEPTION OF FACSIMILE GRAPHIC/NARRATE TRAFFIC OVER DIGITAL SWITCHED VOICE AND DATA NETWORKS, AND COMBAT NET RADIOS, AND SUPPLEMENTS THE SINGLE SUBSCRIBER TERMINAL AND/OR COMMUNICATIONS CENTERS.

COMMUNICATIONS DIRECTORATE

MK-2488/G, INSTALLATION KIT

PROJECT LEADER: Ms. Gloria Richardson,
DSN 992-9196
COMM 732/532-9196
FAX 992-4971
EMAIL: richardson@doim6.monmouth.army.mil

ACQUISITION CATEGORY:
ACQUISITION PHASE:

PE & LINE #: A1-6E50621G04; A1-7E50671G02

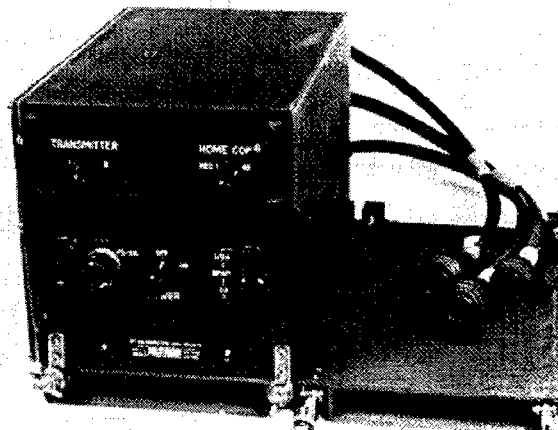

DESCRIPTION: The MK-2488/G Installation Kit is used to maintain electrical capability between older, high-level segnal Teletypewriters (TTYs)/modems and newer, low-level signal security equipment. The Installation Kit consists of an inter-connecting box, cables and mounts installed in various Army TTY-Radio Communication Assemblages. Kit permits replacement of Telecommunications Security (TSEC)/KW-7 by the KG-84 in assemblages with high level signal TTY and modems (TH-5/22, MD-522, TT-4/76/98).

TRANSPORTATION CHARACTERISTICS / LIMITATIONS:

HISTORICAL BACKGROUND:

- 1986 Competitive contract award to Sechan Electronics for 2,412 Production Units; Contract Option exercised for 1,001 additional Production Units from Sechan Electronics.
- 1987 110 Medley Kits installed at Signal Center Ft. Gordon, GA.
- 1988 Sechan production deliveries begin; 82nd and 101st AB issued kits; Korea issued kits.
- 1989 Kit installation began in USAREUR, FORSCOM, Korea.
- 1990 All deliveries completed.

REQUIREMENTS DOCUMENT:

TYPE CLASSIFICATION: Not applicable as units become part of assemblage after kit installation.

RELEASEABLE TO SECURITY ASSISTANCE CUSTOMERS: No

SYNOPSIS: MK-2488/G INSTALLATION KIT IS USED TO MAINTAIN ELECTRICAL COMPATIBILITY BETWEEN OLDER, HIGH-LEVEL SEGRAL TTY/MODEMS AND NEWER, LOW-LEVEL SIGNAL SECURITY EQUIPMENT.

COMMUNICATIONS DIRECTORATE

OG-174/VRC, AMPLIFIER POWER SUPPLY

PROJECT MANAGER: Ms. Deborah Branwell,
DSN 992-9149
COMM 732/532-9149

ACQUISITION CATEGORY: IV
ACQUISITION PHASE: MS IV Operations/Support

PE & LINE #: A53491

DESCRIPTION: The OG-174/VRC Amplifier Power Supply Group is a vehicle applique that permits the installation of an AN/PRC-68A into Self-Propelled Howitzers (M109 and M110) & M577 Command Tracked Vehicles. When the AN/PRC-68A Radio is mounted in this manner, it will provide short range (less than 3KM) vehicle communications. OG-174/VRC also provides an interface for operation with the AM-1780/VRC Amplifier for intercommunication within the vehicle and the AN/GYK-29 Battery Computer System for communication between firing batteries. OG-174/VRC consists of: Amplifier/ Power Supply (vehicle applique); Antenna Coupler; Portable Antenna; Antenna Cable Assembly; and Interface Cable Assembly.

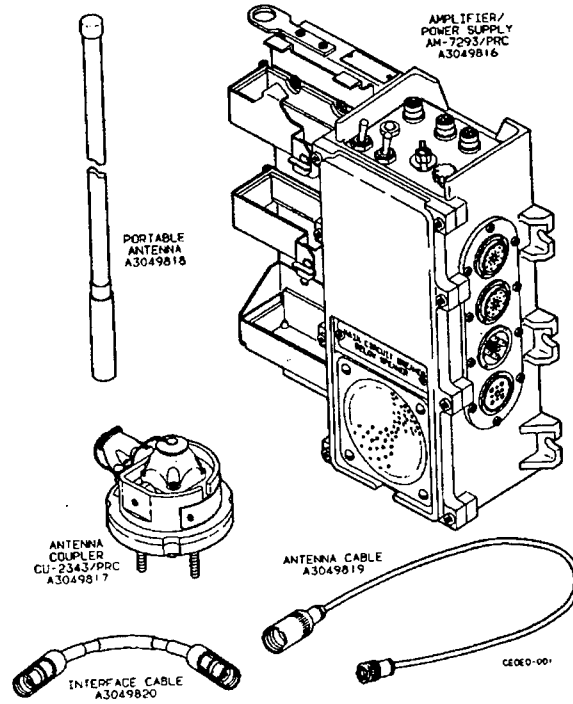

TRANSPORTATION CHARACTERISTICS / LIMITATIONS:

Size: 12.4" L x 11.3" W x 3.9" D; Weight: 13 lbs.

HISTORICAL BACKGROUND:

Sep 84 Contract Award.
Nov 86 Production Qualification Test/First Article Test.
Apr 90 First Unit Equipped.
May 90 Initial Operational Capability.

REQUIREMENTS DOCUMENT: ROC, Apr 79.

TYPE CLASSIFICATION: Limited Procurement approved Dec 82; Extension approved Dec 86; Standard approved Jul 89.

RELEASEABLE TO SECURITY ASSISTANCE CUSTOMERS: No

SYNOPSIS: OG-174/VRC CONSISTS OF AN AMPLIFIER/POWER SUPPLY (VEHICLED APPLIQUE), ANTENNA COUPLER, PORTABLE ANTENNA, ANTENNA AMPLIFIER ASSEMBLY AND INTERFACE CABLE ASSEMBLY.

COMMUNICATIONS DIRECTORATE

SB-3614(V)A/TT, SWITCHBOARD

ITEM MANAGER: Michael Grieb,
DSN 987-4583
COMM 732/427-4583
FAX: DSN 992-9135
COMM 732/532-9135
E-Mail: alsman@doim6.monmouth.army.mil

ACQUISITION CATEGORY: N/A
ACQUISITION PHASE: IV

PE & LINE #: 738017.P1

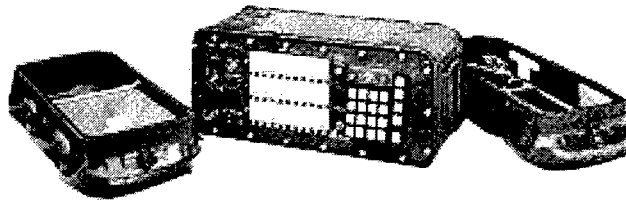

FIGURE 1. SB-3614(V)A/TT SWITCHBOARD

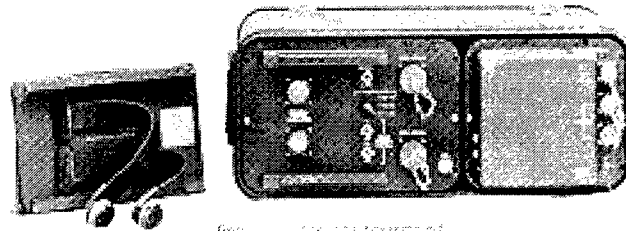

FIGURE 2. SB-3614(V)A/TT SWITCHBOARD

DESCRIPTION: Two Product Improvement Programs (PIPs) were applied to the SB-3614 following its last production in Apr 79. The first PIP (1-81-07-0021) incorporated Dual Central Office Interface and Software Changes adding the capability to interface with civilian dial central offices and included software changes to correct/modify some functional features of the switchboard. These changes were made through the addition of a DCO card and a Programmable Read Only Memory card for each switchboard. The second PIP (1-83-07-0084) was to add a Tandem AUTOVON Capability (changing the system nomenclature to SB-3614A). The Tandem feature allows the SB-3614A subscriber to reach a destination caller by merely dialing the destination subscriber's appropriate seven to ten digit number. The other user services being provided by this PIP are: automatically primary/alternate trunk routing; TRI-TAC numbering plan capability; five levels of precedence; subscriber initiated conferencing; manual/automatic data base entry and dial central office interface. The Marine Corps are the Primary Inventory Control Activity for the SB-3614A switchboard.

TRANSPORTATION CHARACTERISTICS / LIMITATIONS:

HISTORICAL BACKGROUND:

Sep 83 DCO contract award.
Mar 84 Tandem AUTOVON Development contract award.
Sep 85 Tandem AUTOVON Production contract award.
Sep 86 DCO kits distributed and applied.
Jun 87-Apr 90 Tandem AUTOVON Modification Work Order (MWO) applied to units in Germany, CONUS and Korea.
May 90-Sep 93 System fielded as part of the AN/TTC-41(V) under the Battlefield Communication Review (BCR).

REQUIREMENTS DOCUMENT: Qualitative Materiel Requirement, 1972; amended, 31 January 1973.

TYPE CLASSIFICATION: Standard A approved.

RELEASEABLE TO SECURITY ASSISTANCE CUSTOMERS: Yes

SYNOPSIS: SB-3614(V)A/TT IS A 30-TERMINAL AUTOMATIC SWITCHBOARD WHICH PROVIDES RAPID CORDLESS SERVICE.

COMMUNICATIONS DIRECTORATE

FIBER OPTICS TRANSMISSION SYSTEM (FOTS)

PROJECT OFFICER: Mr. Robert Vella,
DSN 992-4607
COMM 732/532-4607
E-Mail: vella@doim6.monmouth.army.mil

ACQUISITION CATEGORY: III
ACQUISITION PHASE: MS III Production/Deployment

PE & LINE #:

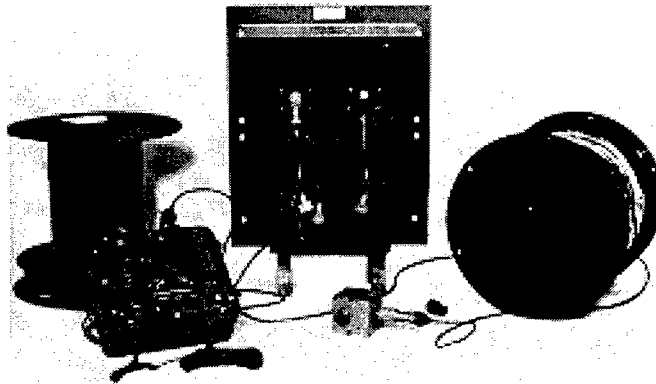

DESCRIPTION: The FOTS is designed to be a replacement for the CX-11230 Coaxial Cable. FOTS is composed of the following equipments: Fiber Optic Modem (FOM); Field Test Set (FTS); Fiber Optic Cable Assembly (FOCA), and Cable Repair Kit (CRK). It also includes a "mud box", which has not yet been procured. The FOM is mounted on the shelter entrance panel and converts the electrical signal to an optical signal for transmission down the FOCA. The FTS is utilized to troubleshoot the cable system. The CRK permits repair and retermination of the FOCA in a sheltered environment. The FOCA is a two fiber cable assembly and is provided in 300 meter and one kilometer lengths. The FOCA is the standard tactical two fiber cable assembly used by all services. The performance requirement for the FOTS is eight kilometers without repeaters.

TRANSPORTATION CHARACTERISTICS / LIMITATIONS: None.

HISTORICAL BACKGROUND:

Feb 79 Special In-Process Review for entry into Full Scale Engineering Development.
Jul 86 DT-II/OT-II completed.
Jul 90 First Article Test (FAT) approved AT&T (FOCA).
Aug 91 FAT approved, FiberCom, Incorporated (FOM & FTS).
Apr 92 Interoperability testing with Marine Corps IAW JTC3ATIS9109C.
Jul 92 Limited User Assessment Test, Ft. Gordon, GA.
Mar 93 FOTS System Test, 63rd Sig BN, Ft. Gordon, GA.

REQUIREMENTS DOCUMENT: ROC approved Nov 81.

TYPE CLASSIFICATION: Standard approved Aug 87.

RELEASEABLE TO SECURITY ASSISTANCE CUSTOMERS: Yes

SYNOPSIS: FOTS IS A REPLACEMENT FOR CX-11230 TWIN COAXIAL CABLE AND OFFERS INCREASED BANDWIDTH, DECREASED DIAMETER AND WEIGHT, INCREASED FLEXIBILITY, ELECTROMAGNETIC PULSE/RADIO FREQUENCY INTERFERENCE (EMP/RFI) IMMUNITY AND LOWER COST.

COMMUNICATIONS DIRECTORATE

REGENCY NET (RN) SYSTEM

PROJECT LEADER Mr. Don Matthews,
DSN 992-9153
COMM 732/532-9153

ACQUISITION CATEGORY: IV
ACQUISITION PHASE: MS IV Operations/Support

PE & LINE #: BB-8422

DESCRIPTION: The RN System is a Tri-Service program. An NDI acquisition to provide USCINCEUR with an independent, agile, survivable, fully supportable HF C3 system with secure data and voice communications, capable of operating in a wartime environment. The AN/TRC-179(V)1 Force Terminal is the primary element of the RN architecture, housed in an S-711 [TRC-179(V)] shelter. Additional major items include the AN/TRC-179(V)3, Split-Site; the AN/GRC-215 Team Terminal; and the PU-794(G) Generator Set.

Regency Net Survivable HF



TRANSPORTATION CHARACTERISTICS / LIMITATIONS:

L = 181, W = 96, H = 87 (inches), Weight = 8,200 lbs.

HISTORICAL BACKGROUND:

May 79 ASDC3I assigned Army as lead service.
May 87 Competitive solicitation awarded to Magnavox Corp.
Dec 91 Decision from DISC4 to PEO COMM.
Apr 92 Conditional Materiel Release approved.
Jun 92 Deployment of RN to CINCEUR initiated.
Sep 92 RN project transitioned to USACECOM.
Aug 95 RN transition from Level II to Level III management.

REQUIREMENTS DOCUMENT: Baseline Requirements Document Validated by JCS - Apr 83.

TYPE CLASSIFICATION: Standard approved 13 Apr 93.

RELEASEABLE TO SECURITY ASSISTANCE CUSTOMERS: No

SYNOPSIS: REGENCY NET HAS REPLACED THE CEMETARY NET SYSTEMS IN EUROPE.

COMMUNICATIONS DIRECTORATE

**VEHICULAR INTERCOMMUNICATIONS SYSTEM
(VIS) AN/VIC-3(V)**

PROJECT OFFICERS: Charlie Penta, Chief VIS SPO
DSN 992-5273
COMM 732/532-5273
EMAIL: penta@doim6.monmouth.army.mil

PROJECT LEADER: Greg Phillips, VIS SPO
DSN 987-2421
COMM 732/427-2421
EMAIL: phillips@doim6.monmouth.army.mil

ACQUISITION CATEGORY: IV
ACQUISITION PHASE: MS III Production/Deployment

PE & LINE #: The AN/VIC-3 does not have a PE of its own. Instead, each of the vehicle programs provide individual fundings for the systems they require.

DESCRIPTION: The VIS is an intercom and radio access communications system, primarily for crew members of combat vehicles. It consists of a Master Control Station (MCS), Full Function Crew Station (FFCS), Monitor Only Station (MOS), Radio Interface Terminal (RIT), Active Noise Reduction (ANR) headsets, and power signal cables. The MCS allows for programming of radios to crew members, radio listening silence, connection to field phone or other vehicle, and connection to two combat radios. An FFCS provides volume adjustment and radio selection whereas an MOS only provides volume adjustment. The RIT is used for applications where three to six radio capability is required. The ANR headsets are provided in a helmet liner with a noise canceling microphone. The ANR earcups will phase cancel noise that penetrates the earcups seal, thereby providing improved noise reduction and hearing protection. Programs which have included VIS equipment in their production or upgrades are vehicles such as Abrams tanks (M1A1/M1A2), Bradley Fighting Vehicles (M2, M3), M577 Command Post, M109A6 Paladins, and Standardized Integrated Command Post System (SICPS). Other vehicles are introducing the VIS as their requirements are clarified. VIS is procured as a Non-Developmental Item.

TRANSPORTATION CHARACTERISTICS / LIMITATIONS: None.

HISTORICAL BACKGROUND:

- Oct 88 \$10M OPA-2 appropriated for VIS.
- Jan 91 SPR decision to procure VIS.
- Sep 92 Contract award.
- Nov 94 Commence First Article Test.
- Jan 96 First Unit Equipped.
- Nov 96 First Article Test Report approved.

REQUIREMENTS DOCUMENT: Required Operational Capability, Jul 86; Amended Apr 96.

TYPE CLASSIFICATION: Generic approved Sep 91; Standard scheduled for Sep 97.

RELEASEABLE TO SECURITY ASSISTANCE CUSTOMERS: Yes

EVENT SCHEDULE	FISCAL YEAR QTR	97				98				99				00				01				02			
		1	2	3	4	1	2	3	4	1	2	3	4	1	2	3	4	1	2	3	4				
Product Improvement (PI) CVC Headset ECP approval		4																							
Type Classification Standard		4																							
Full Materiel Release		4																							
Wireless VIS ECP evaluation						1																			
PI CVC Headset production							4																		
Wireless VIS production (if approved)										1															

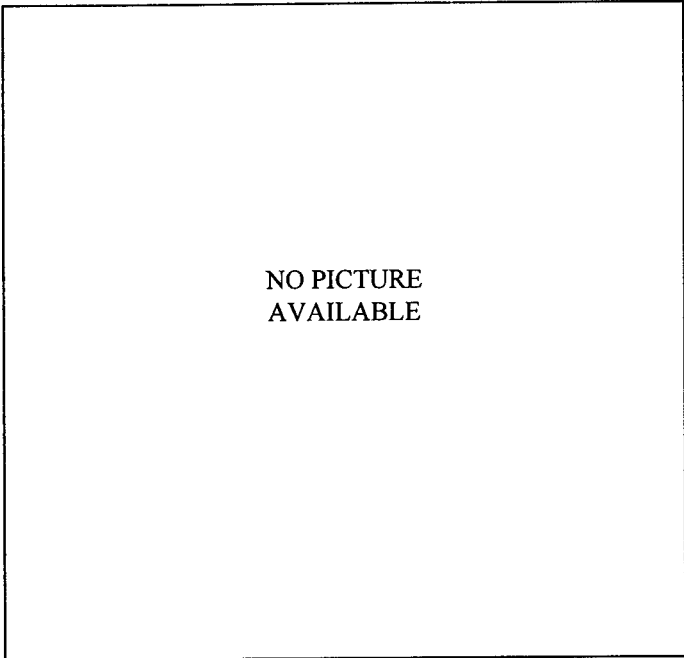

SYNOPSIS: VIS IS AN INTERCOM AND RADIO ACCESS COMMUNICATIONS SYSTEM FOR CREW MEMBERS OF COMBAT VEHICLES.

IEWS

IEWS DIRECTORATE

AN/GRQ-27 and AN/GRQ-27(V)2, GOLDWING

PROJECT OFFICER: Mr. Fidel Amengual,
DSN 987-1038
COMM 732/427-1038

ACQUISITION CATEGORY: IV
ACQUISITION PHASE: MS IV Operations/Support

PE & LINE #: (V2) C60433 / (V1) C90651
SSN: W5990000GCH

DESCRIPTION: GOLDWING provides dedicated IEW communications capability required by Air Force weather teams supporting tactical Army operations. GOLDWING is a low density, secure data communications system employing HF FSK packet radio in the 1.6 to 30 megahertz frequency band. It operates at speeds up to 1200 baud and is designed to support meteorological operations. GOLDWING is a FORSCOM NDI procurement. It is scheduled to officially replace RATT rigs on Air Force weather team modified Tables of Organization and Equipment in the FY92/93 timeframe.

GOLDWING SYSTEM II AN/GRQ-27(V)2 augments the capabilities of the current (V)1 system to include support for automatic weather bulletin processing, automatic weather watch, reception of weather data.

TRANSPORTATION CHARACTERISTICS / LIMITATIONS: Truck Mounted-Shelter.

HISTORIC BACKGROUND:

- FY87 Purchase of initial GOLDWING IEW communication system.
- FY88 Interface of GOLDWING and UAWS; Purchase of WRAASE Satellite Receiver Systems.
- Sep 88 Issued 50 systems to the First Weather Squadron, Fort Gillem with spare and communications technical manuals.
- FY89 Merger of Air Force Quick Reaction and Army GOLDWING Programs.
- Sep 94 System Transitioned from FORSCOM (Level I) to CECOM (Level III).

REQUIREMENTS DOCUMENT: Awaiting O&O approval.

TYPE CLASSIFICATION: Standard B planned.

RELEASEABLE TO SECURITY ASSISTANCE CUSTOMERS: Yes

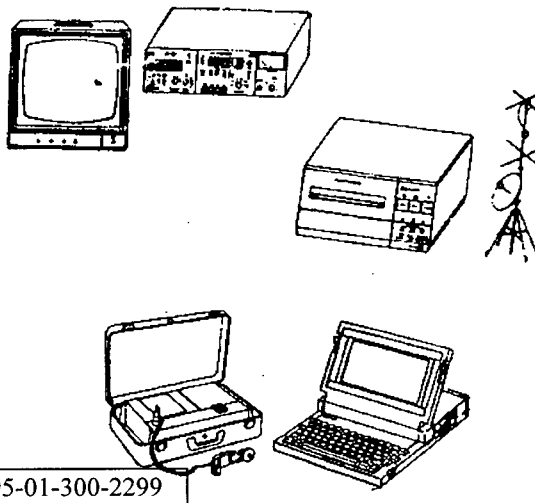

SYNOPSIS: GOLDWING PROVIDES DEDICATED COMMUNICATIONS CAPABILITY REQUIRED BY AIR FORCE WEATHER TEAMS SUPPORTING TACTICAL ARMY OPERATIONS.

IEWS DIRECTORATE

AN/PAQ-4C, INFRARED AIMING LIGHT

PROJECT LEADERS: Ms. Kathleen A. Sporer,
DSN 992-5272
COMM 732/532-5272

Mr. Ronald K. Gibson,

DSN 992-8236
COMM 732/532-8236

ACQUISITION CATEGORY: IV
ACQUISITION PHASE: MS IV Operations/Support

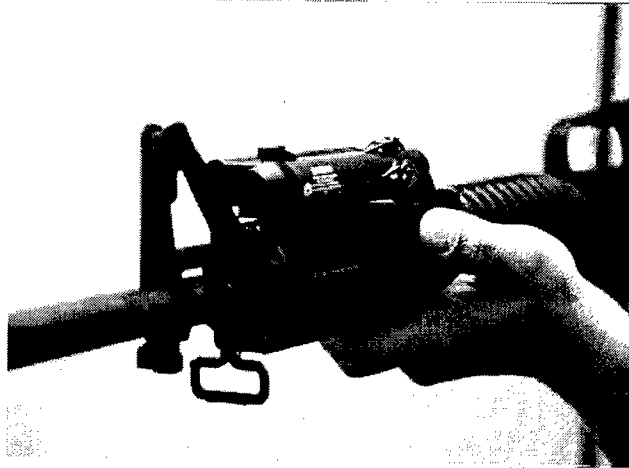

PE & LINE #: SSN: 5855-01-398-4315
LIN: A34938

DESCRIPTION: The AN/PAQ-4C is an infrared aiming light which is attached to the M16 (A1, A2) Rifle, M60 Machine Gun, M2 Machine Gun, M249 SAW, M4 Rifle. AN/PAQ-4C sends out an invisible light beam along the Line-of-Sight. Visible only with night vision goggles, the projected spot of light appears at the exact point where the weapon is aimed. The fired round impacts in the center of the spot of light on the target when properly boresighted. Fielding is two per infantry squad.

TRANSPORTATION CHARACTERISTICS / LIMITATIONS: 5.5" x 2.5" x 1.2", 8" x 12" x 10" (Transit Case).

HISTORICAL BACKGROUND:

- 1979 First Production contract award awarded to Ni-Tech for 1156 units (\$625 each). (AN/PAQ-4).
- 1982 First Unit Equipped; Units sent to SOF.
- Feb 89 SOUTHCOM requested units for mission req'mts; Prod'n contract awarded to Insight Tech. for 10,800 units (AN/PAQ-4A).
- Mar 92 Production awarded to Insight Technology (multi-year buy out). (AN/PAQ-4B)
- Dec 94 Fielding started on the AN/PAQ-4B.
- Jan 95 Fielding started on the AN/PAQ-4C.
- Nov 95 Contract for 29,000 (Army, Marine Corp) awarded to Insight Technology, Inc.
- Jan 96 Contract for 11,700 Marine Corp AN/PAQ-4c's & 7000 Retrofit kits awarded to Insight Technology, Inc.
- Jun 97 Awarded option for 19,000 AN/PAQ-4C.
- Jun 97 Awarded option for 13,400 Retrofit Kits.
- FY98 New Procurement.

REQUIREMENTS DOCUMENT:

Letter Requirement (TRADOC).

TYPE CLASSIFICATION:

Standard (1992)

RELEASEABLE TO SECURITY ASSISTANCE CUSTOMERS: Yes

<u>EVENT SCHEDULE</u>	<u>FISCAL YEAR</u>	97	98	99	00	01	02
		1 2 3 4	1 2 3 4	1 2 3 4	1 2 3 4	1 2 3 4	1 2 3 4
Fielding				4			

SYNOPSIS: THE AN/PAQ-4C IS AN INFRARED AIMING LIGHT ATTACHED TO THE M16 (A1 & A2) RIFLE, M60 MACHINE GUN, M2, M4 MACHINE GUN, M249 SAW THAT SENDS AN INVISIBLE STEADY LIGHT BEAM ALONG THE LINE-OF-SIGHT.

IEWS DIRECTORATE

AN/PEQ-2A INFRARED ILLUMINATOR

PROJECT MANAGERS: Kathleen A. Sporer,
DSN 992-5271
COMM 732/532-5271

Mr. Ronald K. Gibson,

DSN 992-8236
COMM 732/532-8236
FAX: 992-1645
E-Mail: sporer@doim6.monmouth.army.mil

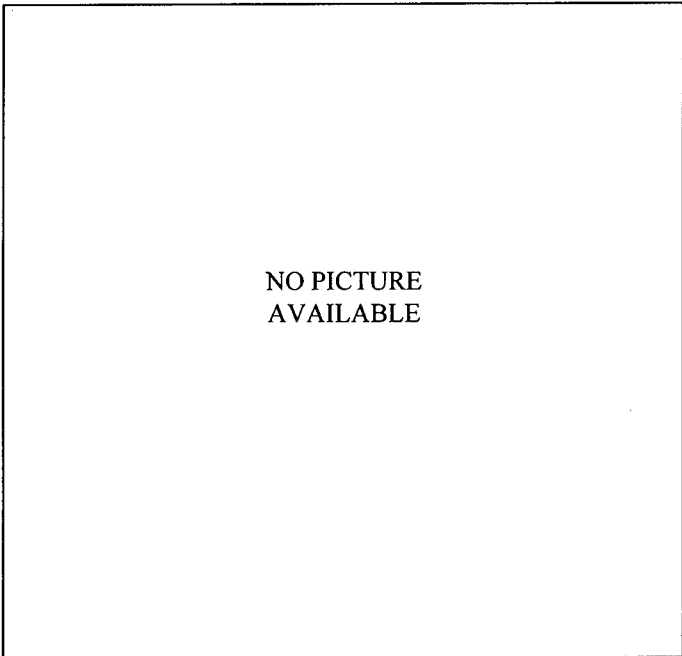

ACQUISITION CATEGORY: IV
ACQUISITION PHASE: MS III

PE & LINE #: NNS 5855-01-447-8992
SSN: W2280000GSG
ZLIN Z52717

DESCRIPTION: The AN/PEQ-2A is for use with Night Vision devices and can be used as either a handheld illuminator/pointer or can be weapon mounted with included brackets and accessory mounts. In weapon mounted mode, the AN/PEQ-2A can be used to accurately direct fire as well as illuminate and designate targets. The AN/PEQ-2A is fully waterproof and can be taken down to extended depths without risk of leakage.

TRANSPORTATION CHARACTERISTICS / LIMITATIONS: 6.4" X 2.8" x 1.2"; 8 x 5.5 x 2.5 (soft carrying case)

HISTORICAL BACKGROUND:

1997 First production contract awarded by an option on an existing Navy contract for 5,100 units. 3,400 are for the Army and 1,700 are for the Marine Corps.
1Q98 First Unit Equipped. Units sent to SOF.
3Q98 Contract for follow-on units

REQUIREMENTS DOCUMENT: ORD signed 22 Jul 97.

TYPE CLASSIFICATION: Gen (1997); Standard (1998).

RELEASEABLE TO SECURITY ASSISTANCE CUSTOMERS: Yes

<u>EVENT SCHEDULE</u>	<u>FISCAL YEAR</u>		97	98	99	00	01	02
	<u>QTR</u>		1 2 3 4	1 2 3 4	1 2 3 4	1 2 3 4	1 2 3 4	1 2 3 4
Contract Award			4					
Fieldings				3				
Follow-on contract				3				

SYNOPSIS: THE AN/PEQ-2A IS FOR USE WITH NIGHT VISION DEVICES AS EITHER A HANDHELD ILLUMINATOR/POINTER OR WEAPON MOUNTED.

IEWS DIRECTORATE

AN/PPS-5B, RADAR SET

ITEM MANAGER: Dorothy Lavoie,
 DSN 992-1568
 COMM 732/532-1568
 FAX DSN 992-9905

ENGINEER: Malek Haddad,
 DSN 992-5105
 COMM 732/532-5105
 FAX DSN 992-9903

ACQUISITION CATEGORY:
ACQUISITION PHASE:

PE & LINE #: C40499, D31557, D31625, D31693

DESCRIPTION: A lightweight, man-portable, ground-to-ground surveillance radar set for use by units such as infantry and tank battalions. The radar is capable of detecting and locating moving personnel and vehicles, day or night under virtually all weather conditions. The radar has a maximum display range of 10,000 meters and targets can be displayed both aurally and visually. Built for durability, the AN/PPS-5B Radar is rugged enough to withstand rough field handling. When packed in its watertight container, it can be parachute dropped and undergo repeated submersion. Increased operational flexibility is afforded when the unit is mounted in a jeep. The system includes everything necessary for operation including 24 VDE external power converter, carrying harnesses, tripod, an adapter for vehicle mounting, four (4) rechargeable batteries (BB-622) and a fifty (50) foot cable for remote operations.

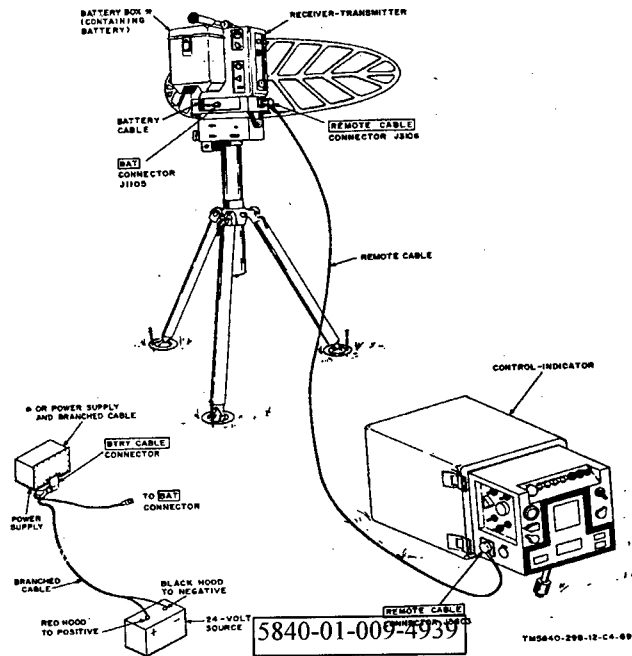

NOTE: The CECOM Supply and Maintenance Bulletin Vol 20, no. 2 Summer 94 provides information for swapping unserviceable AN/PPS-5(A,B) Radars for serviceable ones. Repair is the only source of supply. As soon as one is down, order one through swap out. In order to swap out a radar, the serial number and turn-in document number must be furnished to the Item Manager.

TRANSPORTATION CHARACTERISTICS / LIMITATIONS:

HISTORICAL BACKGROUND:

- Mar 75 Sole Source to Eaton Corp. - AN/PPS-5A Radar.
- May 78 Sole Source to Eaton Corp. - AN/PPS-5B Radar FMS Customer.
- Sep 78 Sole Source to Eaton Corp. - AN/PPS-5B Radar.
- Oct 89 Sole Source to Telephonics Corp. - AN/PPS-5B Radar FMS Customer.
- Apr 94 US Government agreed to accept units built with no-cost warranty against EMI Failures.
- Jul 94 Portugal accepted warranty and contract was modified P00053.

REQUIREMENTS DOCUMENT:

TYPE CLASSIFICATION: Type classified Standard "A" on 3 Jun 78.

RELEASEABLE TO SECURITY ASSISTANCE CUSTOMERS: Yes

EVENT SCHEDULE	FISCAL YEAR		97	98	99	00	01	02
	QTR		1 2 3 4	1 2 3 4	1 2 3 4	1 2 3 4	1 2 3 4	1 2 3 4
Repair of 50 Radars			4	4	4	4	4	4

SYNOPSIS: A LIGHTWEIGHT, MAN-PORTABLE SURVEILLANCE RADAR SET FOR USE BY UNITS SUCH AS INFANTRY AND TANK BATTALIONS.

IEWS DIRECTORATE

AN/PPX-30, INTERROGATOR SET

PROJECT OFFICER: Mr. Dave Seliga,
DSN 987-5297
COMM 732/427-5297

ACQUISITION CATEGORY: IV
ACQUISITION PHASE: MS IV Operations/Support

PE & LINE #: J98501 SSN: C1960000LST

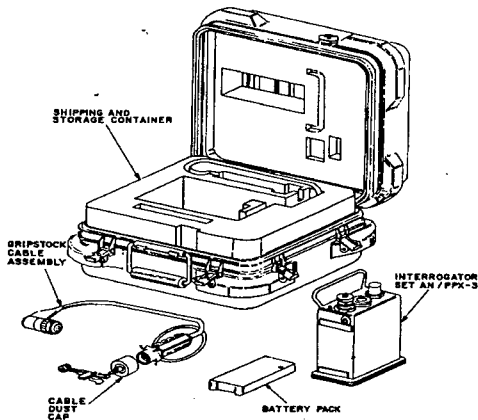

DESCRIPTION: Man portable, ground to air IFF interrogator. Transmits a coded interrogation and receives and processes coded replies. Capable of mode 4 operation compatible with transponders in Mark X (Mode III) and Mark XII (Mode IV) systems. It is worn as a belt pack connected to weapon by plug in cable.

TRANSPORTATION CHARACTERISTICS / LIMITATIONS: None.

HISTORICAL BACKGROUND:

Jan 93 Transitioned from Level III to Level II.
Oct 96 Transitioned to IEWS Dir., CMBTID/RADAR Division.

REQUIREMENTS DOCUMENT:

TYPE CLASSIFICATION: Standard A approved Sep 82.

RELEASEABLE TO SECURITY ASSISTANCE CUSTOMERS: Yes

<u>EVENT SCHEDULE</u>	<u>FISCAL YEAR</u>		97	98	99	00	01	02
	<u>QTR</u>		1 2 3 4	1 2 3 4	1 2 3 4	1 2 3 4	1 2 3 4	1 2 3 4
Awarded competitive A2 Diplexer Module Contract			1					

SYNOPSIS: AN/PPX-3 IS AN INTERROGATOR FRIEND OR FOE (IFF) SYSTEM.

IEWS DIRECTORATE

AN/PRD-11, MINI-FIX

5825-01-188-3435

ITEM MANAGER: Christopher DeLoatch,
DSN 992-9966
COMM 732/532-9966

ACQUISITION CATEGORY:
ACQUISITION PHASE:

PE & LINE #: R36561 SSN: W2340000GWD

DESCRIPTION: The MINI-FIX is a man-portable direction finding system. It is composed of a man-portable vehicular radio receiver and direction finder (DF) processor system, signal monitor, DF processor (the controlling unit in the DF system), and DF antenna. MINI-FIX can be easily transported and maintained in the field, while providing highly accurate intercept and Line-of-Bearing (LOB) information. This system was initially provided to Communications Electronics Warfare Intelligence (CEWI) units via the Intelligence and Security Command (INSCOM) program as an NDI training system.

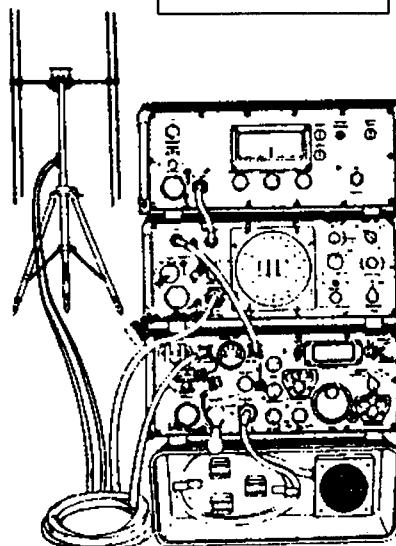

TRANSPORTATION CHARACTERISTICS / LIMITATIONS:

HISTORIC BACKGROUND:

- Dec 79 Purchased by FORSCOM for readiness training. A total of 75 original systems were purchased without ILS.
- Jul 84 CECOM tasked by DA to support FORSCOM in developing ILS.
- Aug 86 Fielding of all ILS by on-site delivery team commenced to Korea Nov 86 and Panama Dec 86.
- Aug 87 Full organic support to all FORSCOM and OCONUS activities.
- Mar 89 System upgraded to include battery charger, high frequency capability, up-converter CV4090.
- Aug 93 Transitioned from FORSCOM (Level I) to CECOM, DMM (Level III).

REQUIREMENTS DOCUMENT: HQDA message authorized procurement, 231742Z Nov 83.

TYPE CLASSIFICATION: Limited Procurement-Urgent approved Jan 89.

RELEASEABLE TO SECURITY ASSISTANCE CUSTOMERS: Yes

SYNOPSIS: MINI-FIX IS A MAN-PORTABLE DIRECTION FINDING SYSTEM.

IEWS DIRECTORATE

AN/PRD-12, LIGHTWEIGHT MANTRANSPORTABLE RADIO DIRECTION FINDER SYSTEM (LMRDFS)

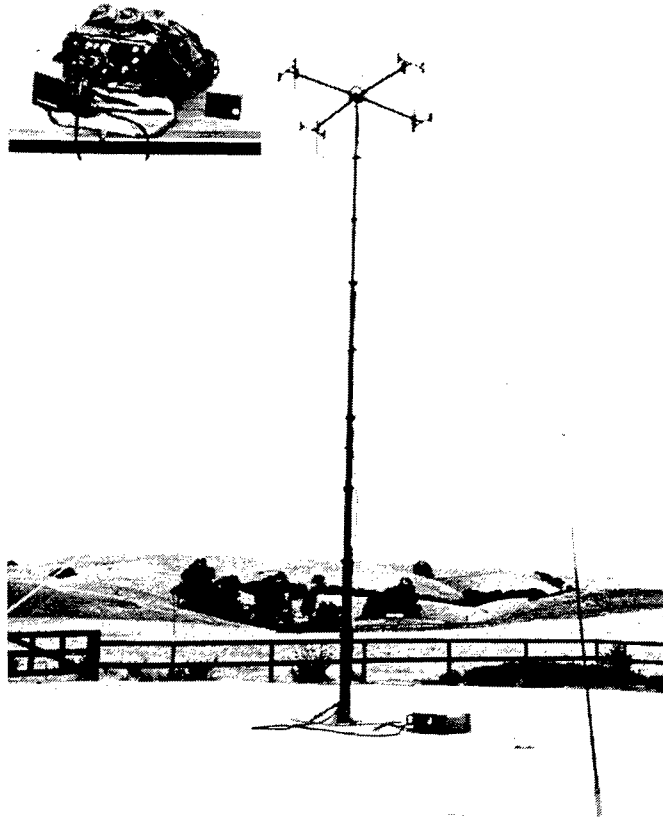

PRODUCT MANAGER: Mr. Enrique Dijamco,
 DSN 992-3440
 COMM 732/532-3440
 FAX 732/532-5079
 E-Mail dijamco@doim6.monmouth.army.mil

ACQUISITION CATEGORY: III
ACQUISITION PHASE: III - Production, Fielding/Deployment, and Operational Support

PE & LINE:

DESCRIPTION: The LMRDFS is a mantransportable ground based communications intercept, processing, and direction finding system. It consists of a receiver/processor and antenna subsystems that can be deployed by two personnel. There are six AN/PRD-12 systems per Light Division and twelve systems per USASOC Special Forces. A total of 110 systems are being procured for FORSCOM/USASOC and TRADOC. Ninety-nine additional systems are being procured for the TEAMMATE HF frequency extension materiel change. The system searches for, intercepts, and provides for direction finding locations of enemy HF/VHF/UHF communications emitters. The AN/PRD-12 will interoperate with the TEAMMATE system via communications links in the direction finding mode. In addition, the PRD-12 has been procured for use in the Marine Corps Top Hunter System.

The AN/PRD-12 will interoperate with the TEAMMATE system via communications links in the direction finding mode. In addition, the PRD-12 has been procured for use in the Marine Corps Top Hunter System.

TRANSPORTATION CHARACTERISTICS / LIMITATIONS: Mantransportable, No Limitations.

HISTORICAL BACKGROUND:

- Dec 87 Contract awarded.
- Jun 89 System Confidence Demonstration.
- Aug 90 Completed testing at Fort Huachuca.
- Nov 90 Contract Modifications awarded to demonstrate frequency extension.
- Apr 93 Initiate System Fieldings.
- Nov 95 Initiate Low Profile Antenna (LPA) upgrade.

REQUIREMENTS DOCUMENT: QRC-59 approved by AEWIC, Jun 86 .

TYPE CLASSIFICATION: LPU based on QRC-59.

RELEASEABLE TO SECURITY ASSISTANCE CUSTOMERS: No

EVENT SCHEDULE	FISCAL YEAR		97	98	99	00	01	02
	QTR		1 2 3 4	1 2 3 4	1 2 3 4	1 2 3 4	1 2 3 4	1 2 3 4
Transition to Readiness			2					
CDU Redesign			-----4					
Field LPA				-----4				

SYNOPSIS: LMRDFS IS A MANTRANSPORTABLE GROUND BASED COMMUNICATIONS INTERCEPT, PROCESSING, AND DIRECTION FINDING SYSTEM.

IEWS DIRECTORATE

AN/PVS-4, NIGHT VISION SIGHT, INDIVIDUAL SERVED WEAPON

PROJECT LEADER: Ms. Alihah Lewis,
DSN 987-1008
COMM 732/427-1008

ACQUISITION CATEGORY: IV
ACQUISITION PHASE: MS III Production/Deployment

PE & LINE #: SSN: K41500

DESCRIPTION: The AN/PVS-4 provides passive sighting and viewing of targets using third generation image intensifier techniques. When mounted on individual weapons, the scope will provide the capability for delivery of accurately aimed fire during hours of darkness. The system is easily installed and removed from the weapon using suitably designed brackets which require no modification to the weapon. A protective objective daylight cover provides the capability for daylight boresighting of the weapon. AN/PVS-4 is primarily designed for use with the M14, M16 Rifles, M60 Machine Gun, M249 Squad Automatic Weapon, M72A1 Rocket Launcher, M203 Grenade Launcher, M240B machine gun, and M4 Rifle. The system is supplied with a suitable shipping case which protects the system. The sight can be used in the hand-held mode for night surveillance. Fielding is two per infantry squad.



TRANSPORTATION CHARACTERISTICS / LIMITATIONS: None.

HISTORICAL BACKGROUND:

- 1976 First Production contract awarded for 47,074 units.
- 1978 First Unit Equipped.
- 1985-89 Total of 16,927 devices produced and deployed to Army units.
- 1990-92 OMNIBUS II award of 24,046 devices for deployment to Army units.
- 4QFY92 Transition management from PEO IEW, PM NVEO to CECOM, SMD.
- Aug 95 Transitioned management from CECOM SMD to CECOM DMM Level III.
- Jun 97 Update to 3rd generation tube and Picatinny rail grabber kit.

REQUIREMENTS DOCUMENT:

TYPE CLASSIFICATION: Standard approved FY77.

RELEASEABLE TO SECURITY ASSISTANCE CUSTOMERS: Yes

SYNOPSIS: AN/PVS-4 PROVIDES PASSIVE SIGHTING AND VIEWING OF TARGETS DURING HOURS OF DARKNESS USING SECOND GENERATION IMAGE INTENSIFIER TECHNIQUES.

IEWS DIRECTORATE

AN/PVS-5A, 5B, 5C, NIGHT VISION GOGGLES

PROJECT MANAGER: Barbara Skinner,
DSN 992-3918
COMM 732/532-3918

ACQUISITION CATEGORY: IV
ACQUISITION PHASE: MS III Production/Deployment

PE & LINE #: SSN: K35101



DESCRIPTION: The AN/PVS-5(), Night Vision Goggles is a second generation head mounted image intensification device which permits the individual soldier to perform a wide variety of tasks at night. These tasks include walking, operating vehicles, surveillance, map reading, maintenance, first aid operations, and engaging enemy targets with direct rifle fire when used in conjunction with the AN/PAQ-4 aiming light. The AN/PVS-5() is binocular and thus utilizes two MX-9916, 18mm image intensifying tubes.

TRANSPORTATION CHARACTERISTICS / LIMITATIONS:

HISTORICAL BACKGROUND:

Prior 85 Total of 33,138 devices produced and deployed to Army Units.
1985 Total of 17,489 devices produced and deployed to Army Units and other services.
4Q92 Transition management from PEO IEW, PM NVEO to CECOM, SMD.
4Q95 Transition management from CECOM, SMD to CECOM, DMM.

REQUIREMENTS DOCUMENT:

TYPE CLASSIFICATION: Standard approved 1975.

RELEASEABLE TO SECURITY ASSISTANCE CUSTOMERS: Yes

SYNOPSIS: AN/PVS-5 () PROVIDES THE INDIVIDUAL SOLDIER TO PERFORM A WIDE VARIETY OF TASKS AT NIGHT USING SECOND GENERATION IMAGE INTENSIFIER TECHNIQUES.

IEWS DIRECTORATE

AN/TLQ-17A(V), TRAFFICJAM

PROJECT LEADER: Mr. William Campbell,
DSN 992-3124
COMM 732/532-3124

ACQUISITION CATEGORY: IV
ACQUISITION PHASE: V

PE & LINE #: BA6101

DESCRIPTION: TRAFFICJAM is a tactical communications jammer. The original system (AN/TLQ-17A(V)1) was configured using two M151 Jeeps and two M416 Towed Trailers. When the Jeeps became obsolete, the AN/TLQ-17A(V)1 was re-configured to a (V)3 which housed the electronics in an S-250 shelter, and used a commercial utility cargo vehicle (CUCV). When the Highly Mobile Multipurpose Wheeled Vehicle (HMMWV) was approved for use by the Army, the CUCV was replaced by the HMMWV. The AN/TLQ-17A(V)2 is the configuration of TRAFFICJAM that is used on the AN/ALQ-151(V)2 (QUICKFIX). The AN/TLQ-17A(V)4 (SANDCRAB) is the designation for the long range COMMINT and Jamming System. SANDCRAB employs the AN/TLQ-17A(V)3 and an OE-317 Antenna System.

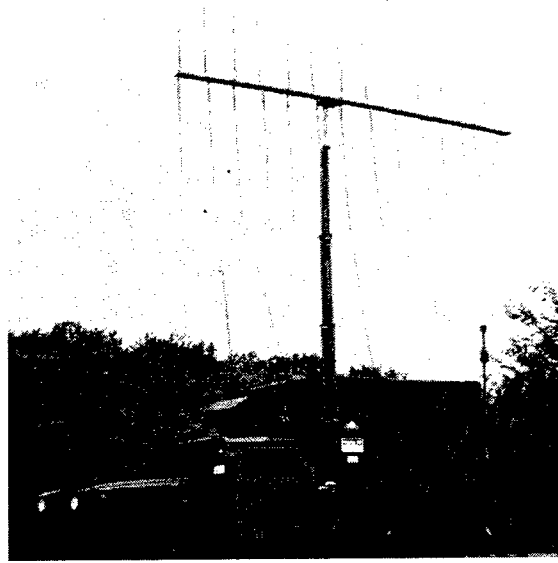

TRANSPORTATION CHARACTERISTICS / LIMITATIONS:

HISTORICAL BACKGROUND:

Mar 85 PIP 1-85-07-0491 approved.
Apr 85 AR 70-15 waived.
Oct 88 First AN/TLQ-17A(V)3 (Commercial Utility Cargo Vehicle (CUCV) Version) fielding.
May 89 CUCV Version fielding completed.
FY90-92 HMMWV fielding completed. System was deployed to Operation Desert Storm.
Jun 92 Management transition from PM SW to IMMC.
Sep 95 Full Materiel Release.
FY95 Materiel Transfer to USAR.

REQUIREMENTS DOCUMENT: PIP 1-85-07-0491.

TYPE CLASSIFICATION: Standard approved Jul 88.

RELEASEABLE TO SECURITY ASSISTANCE CUSTOMERS: Yes

FIELDDED SYSTEMS: 66

SYNOPSIS: TRAFFICJAM IS A TACTICAL GROUND BASED AND AIRBORNE COMMUNICATIONS JAMMER.

IIEWS DIRECTORATE

**AHFEWS
AN/TLQ-33 Equipment**

**AN/TLQ-33, COUNTERMEASURES SET,
ARMY HIGH FREQUENCY ELECTRONIC
WARFARE SYSTEM (AHFEWS)**

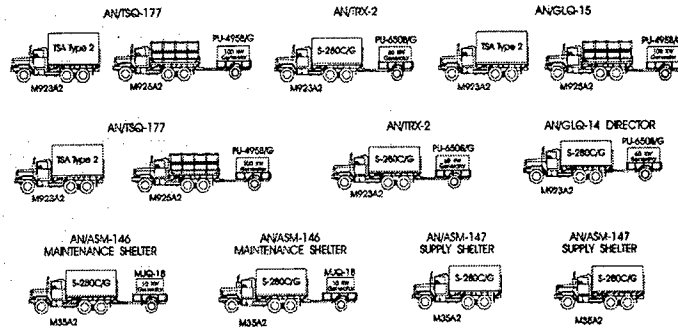

MANAGER: Mr. David Blouin,
DSN 987-1035
COMM 732/427-1035
FAX: 732/427-2961
E-Mail: blouin@doim6.monmouth.army.mil

ACQUISITION CATEGORY: III
ACQUISITION PHASE: IV - Operations & Support

PE & LINE:

DESCRIPTION: AHFEWS is a ground-based high frequency (HF) electronic warfare system consisting of four subsystems: the AN/TSQ-177 Communications Control Set; the AN/TRX-2 Target Recognition System, Non-Cooperative; AN/GLQ-15 Transmitter, Countermeasures and, the AN/GLQ-14, Transmitting Set, Countermeasures. AHFEWS is a one of a kind electronic warfare system fielded and assigned to the 201st MI Battalion of the 513th MI Brigade. The AN/TLQ-33 consists of a mix of shelter sets mounted on 5-ton trucks with support equipment. AHFEWS is designed to perform electronic support for target detection and acquisition of threat HF emitters and executing electronic attack against those emitters. AHFEWS is a stand-alone electronic warfare with secure organic communications for command and control and secure voice communications to a theatre TCAE or J2/3 EW targeting cell of a CINC of U&S Commands or Joint Task Force Commander.

TRANSPORTATION CHARACTERISTICS / LIMITATIONS: AHFEWS may be transported by seallift or airlift (C-141, C-5, or C-17 aircraft). To airlift the entire system will require 6 C-5 missions, however, as few as one C-141 missions is required to transport an AN/TSQ-177 and AN/TRX-2 with all required support equipment. AHFEWS is not to be moved by rail or by helicopter. Road speed is limited to 44 MPH on improved and secondary roads.

HISTORICAL BACKGROUND: By direction of the DA DCSOPS and VCSA in May 1992, AHFEWS was to be built from the residual assets of a terminated SAP to satisfy an outstanding EAC HF electronic warfare requirements identified by the CINCs for EUCOM, CENTCOM, SOUTHCOM, SOCOM, and USFK.

REQUIREMENTS DOCUMENT: AHFEWS ORD, Oct 93.

TYPE CLASSIFICATION: Limited Procurement (Urgent).

RELEASEABLE TO SECURITY ASSISTANCE CUSTOMERS: No

SYNOPSIS: AHFEWS IS AN EAC HF ELECTRONIC WARFARE SYSTEM CAPABLE OF PERFORMING BOTH ELECTRONIC SUPPORT AND ELECTRONIC ATTACK.

IEWS DIRECTORATE

AN/TMQ-31, METEOROLOGICAL DATA SYSTEM (MDS)

PROJECT OFFICER: Mr. Edwin Rivera,
DSN 992-5894
COMM 732/532-5894

ACQUISITION CATEGORY: IV
ACQUISITION PHASE: MS IV Operations/Support

PE & LINE #: M04941 SSN: K27800

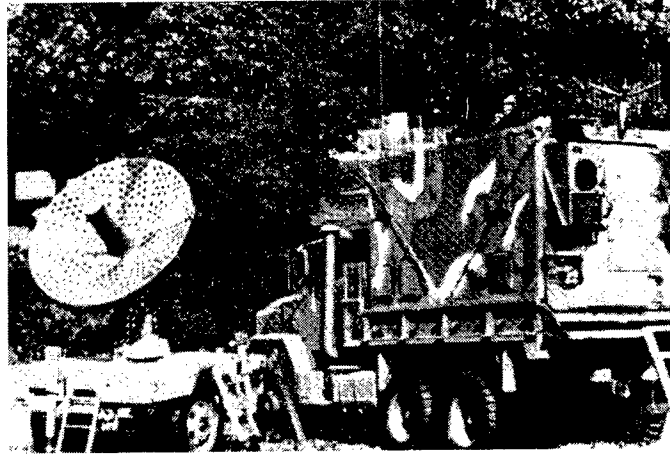

DESCRIPTION: The MDS is a mobile, automated meteorological data acquisition and processing system. This is a stand-alone system that collects meteorological data for artillery fire support. Two MDS's are used to support each Division Artillery Headquarters Battery and one MDS supports each separate Brigade. MDS automatically tracks a balloon-borne meteorological radiosonde as it ascends the atmosphere; receives the telemetered signals of temperature, relative humidity, pressure, and navigation data; measures elevation and azimuth angles to the radiosondes; automatically converts and processes the data; and computes meteorological data for immediate transmission to the user via wire or radio. Two modes of operation are provided: Radio Direction Finding (RDF) mode at 1680 megahertz and NAVAID mode at 400 megahertz.

TRANSPORTATION CHARACTERISTICS / LIMITATIONS: No Transportability Restraints; Approx. 10,000 lbs Mission Equipment, 1750 cubic ft, (L x W x H) 160 x 87 x 83".

HISTORICAL BACKGROUND:

- Aug 84 Production contract award (55 units).
- May 88 Full Release.
- May 93 VECF Kits installation completed.
- Jan 92 Completed fieldings to Army and Marine Corps.
- Oct 92 Transition management from PEO IEW, PM EW/RSTA to CECOM, SMD.
- Jun 95 Management by LRC Sensors Team.
- FY96-97 Redistribute MDS Systems to National Guard.

REQUIREMENTS DOCUMENT: ROC Jun 79, CARDS 0449.

TYPE CLASSIFICATION: Standard approved Sep 83.

RELEASEABLE TO SECURITY ASSISTANCE CUSTOMERS: No - the MDS is going to be phased out in FY99.

<u>EVENT SCHEDULE</u>	FISCAL YEAR	97		98		99		00		01			
		1	2	3	4	1	2	3	4	1	2	3	4
Redistribute to National Guard					4								

SYNOPSIS: AN/TMQ-31 IS A MOBILE, VERSATILE, AUTOMATED METEOROLOGICAL DATA ACQUISITION AND PROCESSING SYSTEM.

IEWS DIRECTORATE

AN/TMQ-38, METEOROLOGICAL MEASURING SET (MMS)

PRODUCT LEADER: Mr. Jose Florido,
DSN 987-5420
COMM 732/427-5420

ACQUISITION CATEGORY: IV
ACQUISITION PHASE: MS IV Operations/Support

PE & LINE #: M36293

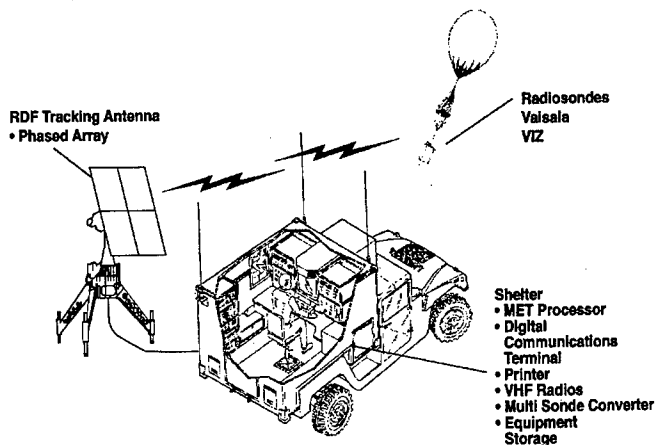

DESCRIPTION: The AN/TMQ-38 Meteorological Measuring Set (MMS) is a transportable group of components for tracking meteorological balloon observations, measuring the atmospheric parameters of temperature, barometric pressure, relative humidity, wind velocity and direction from the earth's surface to extended altitudes.

TRANSPORTATION CHARACTERISTICS / LIMITATIONS: Shelter mounted and transported on HMMWV.

HISTORICAL BACKGROUND:

2QFY90 Contract Award.
FY91 Build FAT Systems.
2QFY92 Test Systems.
1QFY93 Field Systems.
FY96-97 Redistribute six (6) systems to National Guard.

REQUIREMENTS DOCUMENT:

TYPE CLASSIFICATION: Standard.

RELEASEABLE TO SECURITY ASSISTANCE CUSTOMERS: No - the AN/TMQ-38 is expected to be phased out in FY99.

SYNOPSIS: THE MMS IS A TRANSPORTABLE GROUP OF COMPONENTS FOR TRACKING METEOROLOGICAL BALLOON OBSERVATIONS.

IEWS DIRECTORATE

AN/TMQ-41, METEOROLOGICAL MEASURING SET (MMS)

PRODUCT LEADER: Mr. Al Halil,
DSN 992-6816
COMM 732/532-6816

ACQUISITION CATEGORY: IV
ACQUISITION PHASE: MS IV Operations/Support

PE & LINE #: M35941 SSN: K27800

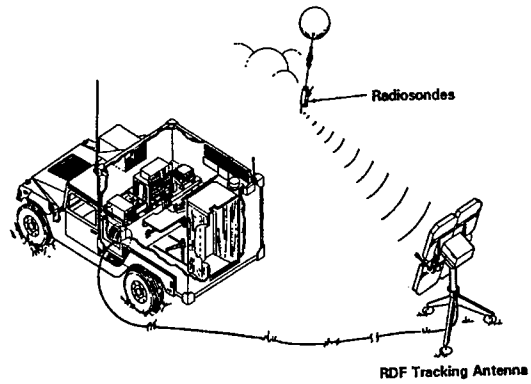

DESCRIPTION: The MMS is an upper air meteorological data collection, processing and dissemination system. The system consists of a radiosonde carried aloft by a balloon and a ground terminal. The system is shelter mounted and transported on a HMMWV. Additional capabilities include multiple radiosonde capability and a Lightweight Computer Unit for future expansion capability. One MMS will be deployed per light division, and two per heavy division. The MMS will provide meteorological data to field artillery units. The system provides pressure, relative humidity, temperature, wind speed and direction measurements to an altitude of 30 kilometers above the earth's surface. The ground terminal automatically acquires and tracks the radiosonde using NAVAID and Radio Direction Finding (RDF) techniques. In the NAVAID mode, the system is capable of using LORAN or any combination of VLF/OMEGA transmissions to determine the radiosonde's position. The ground system will receive telemetered temperature, pressure, humidity, and NAVAID or azimuth and elevation data from the radiosonde depending on the mode of operation. The system reports in standard formats for automated processing at the using units. The system is a replacement for the Meteorological Data System, AN/TMQ-31 which is fielded to the heavy divisions.

TRANSPORTATION CHARACTERISTICS / LIMITATIONS: Mounted and transported on Heavy HMMWV. No transportability restraints. Weight 3,048 lbs. Mission Equipment: 423 cubic ft, (L x W x H) 130 x 84 x 67".

HISTORICAL BACKGROUND:

- Aug 88 ROC Approved.
- Nov 92 Contract Award for 6 FAT Systems.
- Feb 93 Contract Award for 16 Option Systems.
- Dec 93 Contract Award for 18 Option Systems.
- May 94 FAT Completed.
- Jul 94 IOT&E Completed.
- Aug 95 TC Standard.
- Sep 95 Materiel Release.
- Nov 95 FUE.

REQUIREMENTS DOCUMENT: ROC Approved Aug 88.

TYPE CLASSIFICATION: Generic Approved Sep 88; Standard Aug 95.

RELEASEABLE TO SECURITY ASSISTANCE CUSTOMERS: Yes

EVENT SCHEDULE	FISCAL YEAR					
	97	98	99	00	01	02
	1 2 3 4	1 2 3 4	1 2 3 4	1 2 3 4	1 2 3 4	1 2 3 4
	QTR					
Field Systems	-----	-1				

SYNOPSIS: THE MMS IS AN UPPER AIR METEOROLOGICAL DATA COLLECTION, PROCESSING AND DISSEMINATION SYSTEM.

IEWS DIRECTORATE

AN/TMQ-42, HYDROGEN GENERATOR (HG)

PROJECT OFFICER: Mr. Al Halil,
 DSN 992-6816
 COMM 732/532-6816

ACQUISITION CATEGORY:
ACQUISITION PHASE:

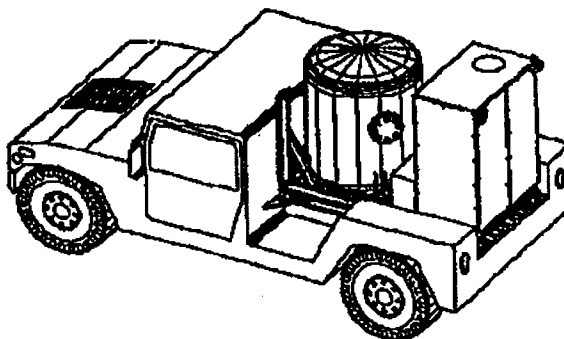

PE & LINE: Z40669 SSN: K27800

DESCRIPTION: The HG is a mobile tactical Hydrogen Generating system used to rapidly inflate meteorological balloons in support of the Field Artillery. The HG is transported on a High Mobility Multipurpose Wheeled Vehicle (HMMWV). Hydrogen is produced by decomposing a mixture of methanol and distilled water in the presence of a catalyst and heat. It is a replacement for the AN/TMQ-3 Hydrogen Generator.

TRANSPORTATION CHARACTERISTICS / LIMITATIONS: No limitations when system purged of hydrogen gas. Weight approx. 2,300 lbs. Mission Equipment, 125 cubic ft, (L x W x H) 84 x 60 x 44".

HISTORICAL BACKGROUND:

- Nov 86 O&O Plan Approved.
- May 90 ROC Approved.
- Mar 94 IPR III TC Generic.
- Apr 94 Contract Award.
- Apr 96 IOT&E Completed.

REQUIREMENTS DOCUMENT: ROC Approved May 1990.

TYPE CLASSIFICATION: Generic Approved Mar 1994.

RELEASEABLE TO SECURITY ASSISTANCE CUSTOMERS: No

<u>EVENT SCHEDULE</u>	<u>FISCAL YEAR</u>							
	97				98			
	1	2	3	4	1	2	3	4
	<u>QTR</u>							
Build Option Systems				2				
TC STD				2				
Field Systems			4				4	

SYNOPSIS: THE HG IS A MOBILE TACTICAL HYDROGEN GENERATING SYSTEM USED TO RAPIDLY INFLATE METEOROLOGICAL BALLOONS IN SUPPORT OF THE FIELD ARTILLERY.

IEWS DIRECTORATE

AN/TRQ-32A(V)2 TEAMMATE

PROJECT MANAGER: Mr. Dave Andreoni,
 DSN 992-9964
 COMM 732/532-9964

ACQUISITION CATEGORY: IV

ACQUISITION PHASE: Operations and Support

PE & LINE #: 112119



DESCRIPTION: The AN/TRQ-32A(V)2 is a High Frequency/Very High Frequency/Ultra High Frequency signal collection and direction-finding system. The system prime mover will be the M1097 Heavy High Mobility Multipurpose Wheeled Vehicle (Heavy HMMWV). The system is housed in an S-250 shelter mounted on the M1097. The AN/TRQ-32A(V)2 is comprised of these subsystems: Electrical Environmental System (EES), Antenna Subsystem, Receiving Subsystem, Direction Finding (DF) Subsystem, Communication Subsystem, Datalink Subsystem, Audio/Record Subsystem, a detachable Lightweight Manportable Radio Direction Finding Set (LMRDFS, AN/PRD-12), and a data link repeater (AN/TSQ-175 Tiger).

TRANSPORTATION CHARACTERISTICS / LIMITATIONS: Shelter: H 70.5 in., L 129.0 in., W 79.4 in., Volume 356 cu ft.
 HHMMWV: H 69.0 in., L 180.0 in.

HISTORICAL BACKGROUND:

- 1988 Initial fieldings of "Production" Version AN/TRQ-32(V)2 worldwide.
- 1994 Follow-on fieldings of upgraded "Production" Version AN/TRQ-32A(V)2.

REQUIREMENTS DOCUMENT:

TYPE CLASSIFICATION: LP June 1995 extended 1 year.

RELEASEABLE TO SECURITY ASSISTANCE CUSTOMERS: No

EVENT SCHEDULE	FISCAL YEAR QTR	97		98		99		00		01		02	
		1	2	3	4	1	2	3	4	1	2	3	4
EES Kit upgrade				1		2							
Swapout of GRID "OT" Terminal (some systems)		2		2									
Replacement of SWA Design (Design thru fielding)		2			4								
Installation of signal limiter circuit				1-2									

SYNOPSIS: HIGH FREQUENCY/VERY HIGH FREQUENCY/ULTRA HIGH FREQUENCY SIGNAL COLLECTION AND DIRECTION FINDING SYSTEM.

IEWS DIRECTORATE

5820-01-160-4684

AN/TRQ-37, TACFIX

PROJECT OFFICER: Glen Van Syckle,
DSN 992-9967
COMM 732/532-9967

ACQUISITION CATEGORY: IV
ACQUISITION PHASE: MS IV Operations/Support

PE & LINE #: LIN R38883

DESCRIPTION: TACFIX is a shelter mounted direction finder system. It is used by Communications Electronics Warfare Intelligence (CEWI) units. This equipment is designed with two direction finder (DF) receivers, a quick erecting DF antenna/mast assembly, and a DF processor. TACFIX provides Line-of-Bearing data only and must be manually controlled to provide true DF.

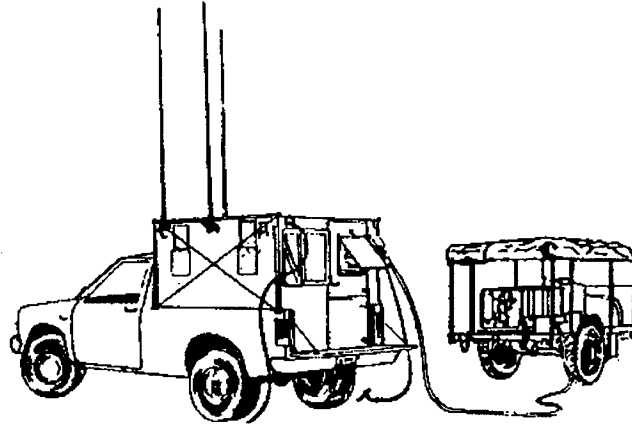

TRANSPORTATION CHARACTERISTICS / LIMITATIONS: Truck Mounted-Shelter.

HISTORICAL BACKGROUND:

- Sep 79 Purchased by FORSCOM for readiness training. A total of 35 original systems were purchased without life-cycle ILS.
- Jan 84 CECOM tasked by DA to support FORSCOM by developing ILS.
- Jun 86 Spare and repair parts in place.
- Sep 87 Antenna design change to install in shelter.
- Apr 89 Procurement data package submitted to upgrade system capabilities.
- Jun 89 Full depot support established at TOAD.
- Feb 94 System transitioned from FORSCOM (Level I) to CECOM (Level II).

REQUIREMENTS DOCUMENT: HQDA message authorized procurement 231742Z Nov 83.

TYPE CLASSIFICATION: Standard approved Dec 89.

RELEASEABLE TO SECURITY ASSISTANCE CUSTOMERS: Yes

SYNOPSIS: TACFIX IS A SHELTER MOUNTED DIRECTION FINDER SYSTEM.

IEWS DIRECTORATE

**AN/TRS-2(V), PLATOON EARLY WARNING
SYSTEM (PEWS)**

PROJECT OFFICER: Mr. Leopold Maddalena,
DSN 992-9359
COMM 732/532-9359

ACQUISITION CATEGORY: IV
ACQUISITION PHASE: MS IV Operations/Support

PE & LINE #: P06148

DESCRIPTION: An operational AN/TRS-2(V) consists of ten detector anti-intrusion devices, two radio receivers, two interface wire links and other accessories packaged in two carrying bags. The system will operate in a variety of different types of terrain and under extreme temperature and climatic conditions with a very low false alarm rate.

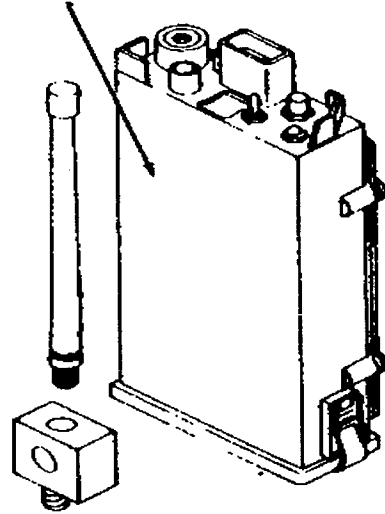

TRANSPORTATION CHARACTERISTICS / LIMITATIONS: System packed in two bags. Each bag - Length 18", Width 6", Height 6.6", Weight 11 lbs.

HISTORICAL BACKGROUND:

Apr 76 Milestone Decision Review.
Jul 78 Contract award.
Sep 80 Test.
Dec 80 First Unit Equipped.
Mar 81 Initial Operational Capability.
Sep 92 Transition.

REQUIREMENTS DOCUMENT: Initial ROC approved, 26 Nov 62; Final ROC approved, 19 Oct 72.

TYPE CLASSIFICATION: Standard A approved Apr 78.

RELEASEABLE TO SECURITY ASSISTANCE CUSTOMERS: No

SYNOPSIS: AN/TRS-2(V) IS AN OPERATIONAL SYSTEM CONSISTING OF TEN DETECTORS, TWO RADIO RECEIVERS, TWO INTERFACE WIRE LINKS AND OTHER ACCESSORIES PACKAGED IN TWO CARRYING BAGS.

IEWS DIRECTORATE

AN/TSQ-138, TRAILBLAZER

PROJECT LEADER: Mrs. Kathleen Morgan,
 DSN 987-6406
 COMM 732/427-6406
 FAX: 732/427-6016

ACQUISITION CATEGORY: III
ACQUISITION PHASE: MS IV Production/Deployment
 (Applies to Materiel Change)
 Basic system is in Phase V

PE & LINE #: 3.58.85 (TCP) SSN: BZ9751

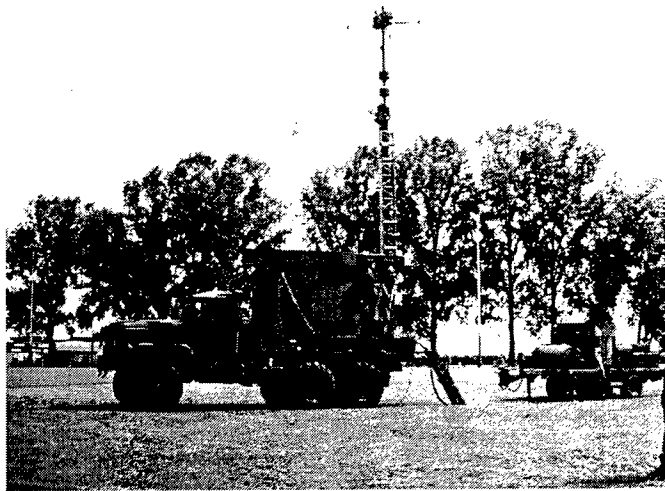

DESCRIPTION: TRAILBLAZER is a high capacity ground based communications intercept, processing, and direction finding system. It is mounted in a shelter carried on a M923A2 5-Ton Vehicle which tows a 30 Kw generator. AAO is for five TRAILBLAZER systems assigned to each Heavy Division. A total of 68 systems were procured. The system is used to search for, intercept, record, identify, locate (VHF/UHF 20-90 Mhz Range) and report on radio signals in the HF/VHF/UHF frequency ranges. The system operates in a netted configuration and interoperates with the airborne QUICKFIX system and the AN/TRQ-32A TEAMMATE system for direction finding. Recently completed materiel changes include addition of: an enhanced self location capability; a digital temporary storage recorder; and network radio protocol upgrade providing improved connectivity with TCAC, ASAS, and other Intelligence and Electronic Warfare Systems. The current materiel change program is designed to maintain operational capability pending the fielding of the Ground Based Common Sensor Heavy (GBCS-H).

TRANSPORTATION CHARACTERISTICS / LIMITATIONS C130 / C141 / C5 Transportable (Shelter removed from carrier).

HISTORICAL BACKGROUND:

- Jul 85 AN/TSQ-138 Production contract awarded.
- Apr 88 TRAILBLAZER/QUICKFIX interoperability demonstration.
- Aug 88 FUE AN/TSQ-138.
- Sep 90 Fielding completed; Materiel Change Program Initiated.
- Mar 93 Transition to IMMC.
- Aug 94 Fielding completed of materiel change program.
- May 95 Transition to IMMC.

REQUIREMENTS DOCUMENT: TRAILBLAZER ROC, Jun 84.

TYPE CLASSIFICATION: TRAILBLAZER, Standard, Sep 90.

RELEASEABLE TO SECURITY ASSISTANCE CUSTOMERS: Yes - V12; No - V20

<u>EVENT SCHEDULE</u>	<u>FISCAL YEAR</u>		97	98	99	00	01	02
	<u>QTR</u>		1 2 3 4	1 2 3 4	1 2 3 4	1 2 3 4	1 2 3 4	1 2 3 4
Interference cancellation MOD Production				4				
Fielding			4	4				
TSU//Mast/DC Master Switch/ECPS/Upgrade			1	3				

SYNOPSIS: TRAILBLAZER IS A HIGH CAPACITY GROUND BASED COMMUNICATIONS INTERCEPT, PROCESSING, AND DIRECTION FINDING SYSTEM.

IEWS DIRECTORATE

AN/TSQ-152, TRACKWOLF

PROJECT MANAGER: Mr. Roy Weaver,
DSN 987-1025
COMM 732/427-1025
FAX 732/427-6016
E-Mail weaverr@doim6.monmouth.army.mil

ACQUISITION CATEGORY: III
ACQUISITION PHASE: MS IV Operations & Support

PE & LINE #: SSN: BZ9750



DESCRIPTION: TRACKWOLF is a mobile, ground based High Frequency (HF) skywave communications intercept and direction finding system. It consists of a Direction Finding Subsystem (DFS) and a Collection and Processing Subsystem (CPS). TRACKWOLF is an Echelons Above Corps asset assigned to MI Battalions. To meet original SIGINT requirements, a contract was awarded for one TRACKWOLF system with four additional systems identified as options. Because the first system was not delivered until FY92, two options were never exercised. Due to "Revised" Congressional direction in FY92/93 concerning the need for a rapidly deployable system, the remaining contract was canceled and a new procurement action started. This "New" system required a design that could be either mounted on Heavy High Mobility Multipurpose Wheeled Vehicles (HMMWVs) or mounted in man-portable transit cases (the later requirements is presently designed as Enhanced TRACKWOLF (AN/TSQ-199)). The system capabilities include automated direction finding using single station location technology coupled with collection, processing, analysis and reporting functions. TRACKWOLF replaces the obsolete Operational Unit Transportable Systems (OUTS) which utilizes tube technology and does not possess the necessary mobility to be deployed on today's battlefield. TRACKWOLF DFS consists of AN/TRD-27 Direction Finding/Single Station Location Shelters and AN/TRQ-41 HF Sounder/Communications Shelters each carried on standard 5-ton trucks and 3 outstations, each consisting of one AN/TRD-27 and one AN/TRQ-41. The CPS consists of eight (8) AN/TRR-36 Communications/Signal Search Shelters, two (2) AN/TSY-1 Collection/Processing Shelters, and two (2) AN/TSX-1 Analysis Shelters also mounted on standard Army 5-ton trucks. The system will interoperate with EAC Intelligence/Electronic Warfare Analysis systems including TOPGALLANT/SSP-S/ASAS. A large portion of the mission equipment procured was Non-Developmental Item modules controlled by software developed by NSA for strategic sites.

TRANSPORTATION CHARACTERISTICS / LIMITATIONS: System prime mover is 5 ton truck. Can be transported by air, land, rail or ship.

HISTORICAL BACKGROUND:

Sep 88 Contract Award.
May 89 Critical Design Review conducted.
4QFY91 IOT&E.
1QFY93 FUE.
3QFY95 Transition to Level II.

REQUIREMENTS DOCUMENT: QRC-60, Nov 86.

TYPE CLASSIFICATION: Limited Procurement Urgent approved Nov 86.

RELEASEABLE TO SECURITY ASSISTANCE CUSTOMERS: No

SYNOPSIS: TRACKWOLF IS A MOBILE GROUND BASED HF SKYWAVE COMMUNICATIONS INTERCEPT AND DFS EMPLOYED AT ECHELONS ABOVE CORPS.

IEWS DIRECTORATE

AN/TSQ-199, ENHANCED TRACKWOLF (ET)

PRODUCT MGR: Mr. Roy F. Weaver,
 DSN 987-1025
 COMM 732/427-1025
 FAX: 732/427-2961
 E-Mail: weaver@doim6.monmouth.army.mil

ACQUISITION CATEGORY: III
ACQUISITION PHASE: III - Production/Deployment

PE & LINE #: V18200

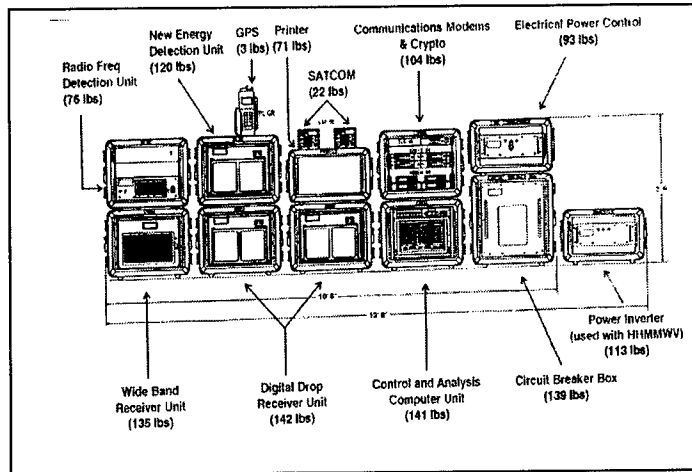

DESCRIPTION: Enhanced TRACKWOLF (ET) is an Echelon Above Corps (EAC) ground based, man-transportable transit case High Frequency direction finding and intercept system. The program was directed by Congress in FY93 as a result of Desert Shield/Desert Storm, during which the current TRACKWOLF system proved too large and cumbersome for rapid deployment. In addition to transportability advantages from the current TRACKWOLF system, ET will incorporate several capabilities that will allow intercept of the most modern modulations. The system consists of six stations, each with nine positions each configured as 1 DF, 2 Management/Analysis, and 6 Collection functions. Set-up/tear-down times are less than four hours and each site uses less than 4000 watts. The architecture is designed to be an integration of proven technologies, with extensive use of non-developmental hardware and software. Additional satellite capability will be added in FY98.

TRANSPORTATION CHARACTERISTICS / LIMITATIONS: Transit Case Configuration; Man Transportable.

HISTORICAL BACKGROUND: ET is an evolutionary step from the TRACKWOLF program, with greater transportability, capability, and operational flexibility. Contract awarded March 94.

REQUIREMENTS DOCUMENT: ORD, dated 13 April 93.

TYPE CLASSIFICATION: Limited Procurement Urgent (LPU).

RELEASEABLE TO SECURITY ASSISTANCE CUSTOMERS: No

EVENT SCHEDULE	FISCAL YEAR	97	98	99	00	01	02
		1 2 3 4	1 2 3 4	1 2 3 4	1 2 3 4	1 2 3 4	1 2 3 4
Production initial and additional stations	QTR	-----3					
Customer Test		1					
FUE		2					
FAT		3					
Delivery (Split system)		4					

SYNOPSIS: THE ENHANCED TRACKWOLF IS AN ECHELON ABOVE CORPUS, GROUND BASED, HF DIRECTION FINDING AND INTERCEPT SYSTEM.

IEWS DIRECTORATE

AN/TVS-5, CREW SERVED WEAPON SIGHT

PROJECT OFFICER: Nilsa Torres,
DSN 992-4795
COMM 732/532-4795

ACQUISITION CATEGORY: IV
ACQUISITION PHASE: MS III Production/Deployment

PE & LINE #: SSN: K3850



DESCRIPTION: The AN/TVS-5 provides sighting and viewing of targets using a second generation image intensifier tube. When mounted on crew served weapons, the scope will provide the capability for delivery of accurately aimed fire during hours of darkness. AN/TVS-5 is primarily designed for use with the M2 and M60 Machine Gun and the 106mm Recoilless Rifle. The system is supplied with a suitable shipping case which protects the system. The sight can be used in the handheld mode for night surveillance by individual soldiers, commanders and reconnaissance elements. Fielding to Army units is complete. The Army is no longer procuring the second generation AN/TVS-5 weapon sight. Supplement/replacement system is the AN/PAS-13, Thermal Weapon Sight (TWS). However, we will continue to procure this device in support of other requirements, predominantly the Marine Corps and FMS.

TRANSPORTATION CHARACTERISTICS / LIMITATIONS: None.

HISTORICAL BACKGROUND:

1976 First Production contract award.
1978 First Unit Equipped.
1985-89 OMNIBUS Multi-year contract in effect for Marine Corps requirements (856 units).
1987-90 MINIBUS Multi-year contract in effect for other DOD requirements.
Feb 1991 Contract award for Operation Desert Storm requirements (2138 units).
Sep 92 Transition from PM, NVEO to CECOM Level II Management.
Dec 95 Transition from CECOM SMD Level II to CECOM DMM Level III.

REQUIREMENTS DOCUMENT:

TYPE CLASSIFICATION: Standard approved FY77.

RELEASEABLE TO SECURITY ASSISTANCE CUSTOMERS: Yes

SYNOPSIS: AN/TVS-5 PROVIDES SIGHTING AND VIEWING USING SECOND GENERATION IMAGE INTENSIFIER TECHNIQUES AND PROVIDES THE CAPABILITY OF ACCURATELY AIMED FIRE DURING HOURS OF DARKNESS.

IEWS DIRECTORATE

AN/ULQ-19(V), SIGNAL JAMMER RACJAM

PROJECT OFFICER: Ms. Barbara Haggerty,
DSN 992-9513
COMM 732/532-9513

ACQUISITION CATEGORY: IV
ACQUISITION PHASE: MS IV Operations/Support

PE & LINE #: LIN Z63802 (RACJAM)
LIN H43290 (HACJ)

DESCRIPTION: AN/ULQ-19(V) RACJAM is a fully automatic, mobile, responsive Very High Frequency (VHF) jammer capable of automatically detecting and jamming signal activity on any one of 16 pre-selected target channels. The system can be programmed to scan several frequencies and while disrupting non-friendly transmissions. AN/ULQ-19(V)3 HAC-J is the helicopter borne version of the jammer.

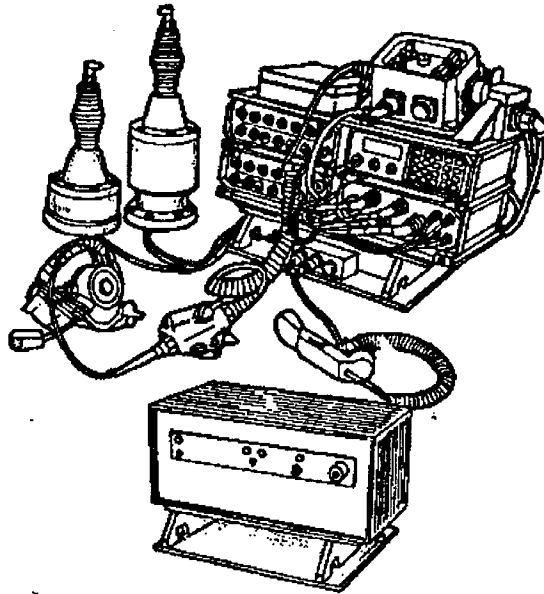

TRANSPORTATION CHARACTERISTICS / LIMITATIONS: V3-Helicopter Mounted, V1/V2-Truck Mounted-Shelter.

HISTORICAL BACKGROUND:

Dec 83 Purchased by FORSCOM for readiness training, total of 20 original systems purchased without life cycle support.
Jan 84 CECOM tasked by DA to support FORSCOM by developing ILS.
Sep 84 ILS management team established.
Mar 86 Spare and repair parts list submitted to contractor for price quotes.
Mar 90 Contract for Heliborne Applique Communications-Jammer (HAC-J) established.
Aug 94 System Transitioned from FORSCOM (Level I) to CECOM (Level III).

REQUIREMENTS DOCUMENT: DA message 032045Z Jan 84.

TYPE CLASSIFICATION: LCC Standard B.

RELEASEABLE TO SECURITY ASSISTANCE CUSTOMERS: Yes

SYNOPSIS: AN/ULQ-19 RACJAM IS A FULLY AUTOMATIC, MOBILE, RESPONSIVE VHF JAMMER CAPABLE OF AUTOMATICALLY DETECTING AND JAMMING SIGNAL ACTIVITY ON ANY 1 OF 16 PRE-SELECTED TARGET CHANNELS.

IEWS DIRECTORATE

AN/USD-9A, IMPROVED GUARDRAIL V (IGR V)

PRODUCT MANAGER: Mr. Charles Scarpino,
DSN 987-5571
COMM 732/427-5571

ACQUISITION CATEGORY: IV
ACQUISITION PHASE: MS IV Operations/Support

PE & LINE #: SSN: AZ2100

DESCRIPTION: The IGR V is an airborne Communications Intelligence (COMINT) collection/location system. AN/USD-9A consists of airborne collection platforms (RC-12D), AN/TSQ-105(V)4 Information Processing Facility (IPF), AN/TSC-116 Improved Commanders Tactical Terminal (ICTT), AN/ARW-83(V)5 Airborne Relay Facility (ARF), AN/AMR-163(V)4 Auxiliary Ground Equipment (AGE) and an Interoperable Data Link (IDL). Current major upgrade is to provide satellite remote capability for both IGRV and insertion into GUARDRAIL/Common Sensor.

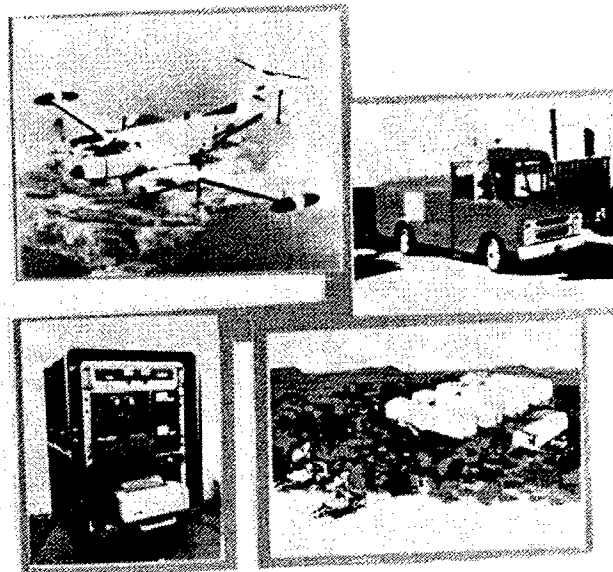

TRANSPORTATION CHARACTERISTICS / LIMITATIONS:

HISTORICAL BACKGROUND:

- Sep 81 Contract award.
- Dec 84 Materiel Release; System 1 fielded to V Corps.
- Dec 85 System 2 fielded to VII Corps.
- Jul 93 System 1 fielded to III Corps.

REQUIREMENTS DOCUMENT: Materiel change to GUARDRAIL; ROC approved, 1979.

TYPE CLASSIFICATION: Standard A, Aug 94.

RELEASEABLE TO SECURITY ASSISTANCE CUSTOMERS: No

SYNOPSIS: IGR V IS AN AIRBORNE COMINT COLLECTION/LOCATION SYSTEM.

IEWS DIRECTORATE

AN/VVS-2, DRIVERS VIEWER

PROJECT OFFICER: Mr. Joseph Hussey,
DSN 987-1009
COMM 732/427-1009

ACQUISITION CATEGORY: IV
ACQUISITION PHASE: MS III Production/Deployment

PE & LINE #: (Stock Funded)

DESCRIPTION: The Drivers Viewer enables a closed hatched vehicle to be driven under night conditions without active illumination. The area viewed is presented as a green image display. It is lightweight enough to be installed from within the vehicle and can be manually rotated from between 30° to 45° depending on the vehicle in which it is to be mounted. Drivers Viewer is presently being installed in the Bradley, M1 and M60 Tanks. Future plans also include purchase of AN/VVS-2 for M113 and M109 vehicles. Fielding is one per tracked vehicle. This system will be replaced or supplemented in the M1A2 and M2/M3 vehicles by the Drivers Thermal Viewer.

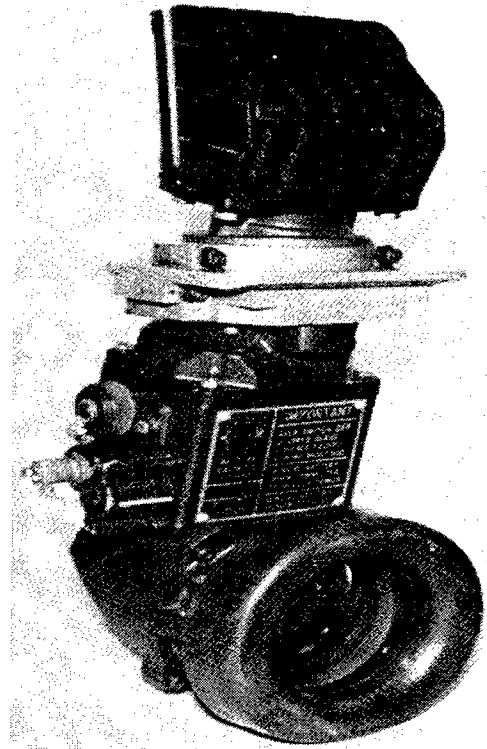

TRANSPORTATION CHARACTERISTICS / LIMITATIONS: None.

HISTORICAL BACKGROUND:

- 1976 NVEOC first Production contract award.
- 1978 First Unit Equipped.
- 1985-89 Five-year OMNIBUS I contract awarded ITT/Varo.
- 1990-92 Three-year OMNIBUS II contract awarded to IMO/VARO.
- Aug 92 Transition from PM, NVEO to CECOM Level II Management.
- Aug 95 Transitioned from CECOM SMD to CECOM DMM Level III.

REQUIREMENTS DOCUMENT:

TYPE CLASSIFICATION: Standard approved FY77.

RELEASEABLE TO SECURITY ASSISTANCE CUSTOMERS: Yes

SYNOPSIS: AN/VVS-2 ENABLES A CLOSED HATCHED VEHICLE TO BE DRIVEN UNDER DARK NIGHT AND STARLIGHT CONDITIONS WITHOUT ACTIVE ILLUMINATION.

IEWS DIRECTORATE

EH-60A, QUICKFIX

PROJECT LEADER: Mr. Mike White,
DSN 992-9909
COMM 732/532-9909

ACQUISITION CATEGORY: IV
ACQUISITION PHASE: II

PE & LINE #: 6.47.20.DK12 SSN: AB3000



DESCRIPTION: The AN/ALQ-151 (V)2 Special Purpose Electronic Countermeasure System, QUICKFIX, is a Heliborne Electronic Warfare system. The AN/ALQ-151 (V)2 Special Purpose Electronic Countermeasure System incorporates the EH-60A Helicopter, AN/TLQ-17A (V)2 Jammer, Electronic Countermeasure (ECM) group, Electronic Support Measure (ESM) equipment for active ECM, Airborne Radio Direction Finder (ARDF) data processing and a suite of Aircraft Survivability Equipment (ASE). Voice and data link communications between other airborne QUICKFIX systems and select ground systems are provided via secure communications. A total of 66 systems were procured. QUICKFIX Systems NET with each other and interop with TRAILBLAZER in a NETTED configuration for DF purposes. Material changes include fielding of software to permit QUICKFIX to interop with TEAMMATE which has connectivity with Technical Control and Analysis Center (TCAC) and ASAS. This will dramatically improve performance in Light Divisions and Armored Cavalry Regiments. Further system improvements will evolve select AN/ALQ-151 (V)2 QUICKFIX Systems into the Advanced QUICKFIX (AQF).

TRANSPORTATION CHARACTERISTICS / LIMITATIONS: Ferry flight when practicable. A maximum of six QUICKFIX systems can be transported by C-5A with minimum disassembly requirements. A maximum of two QUICKFIX systems can be transported by C-141B with relatively extensive disassembly and adjustments.

HISTORICAL BACKGROUND:

- Apr 83 EH-60A Prototype delivered. (PIP) Upgrade.
- Sep 84 Production contract award.
- Feb 88 First Unit Equipped.
- Apr 88 TRAILBLAZER/QUICKFIX/TEAMMATE Interoperability Demonstration.
- Mar 90 Product completed.
- Mar 93 Transition to Level II Management.

REQUIREMENTS DOCUMENT: ROC, May 84.

TYPE CLASSIFICATION: Standard approved Nov 77.

RELEASEABLE TO SECURITY ASSISTANCE CUSTOMERS: No

SYNOPSIS: QUICKFIX IS A TACTICAL HELIBORNE COMMUNICATIONS, INTERCEPT, DIRECTION FINDING, AND JAMMING SYSTEM.

IEWS DIRECTORATE

IMPROVED-REMOTELY MONITORED BATTLE-FIELD SENSOR SYSTEM (I-REMBASS)

PROJECT MANAGER: MAJ Ferdinand Raguindin,
DSN 992-6757
COMM 732/532-6757

ACQUISITION CATEGORY: III
ACQUISITION PHASE: MS III Production/Deployment

PE & LINE #: 23751.D475 SSN: BP1002

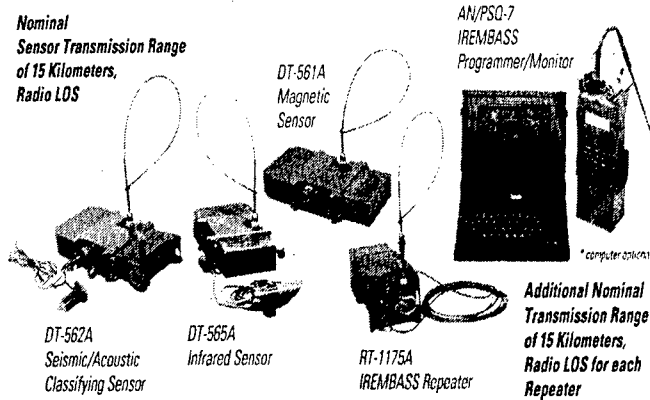

DESCRIPTION: The I-REMBASS is an all weather, day/night, passive, ground-based unattended sensor system. It is a downsized derivative of the fielded REMBASS systems. I-REMBASS consists of three types of sensors (passive IR, magnetic, and seismic-acoustic), the hand-held Monitor Programmer (AN/PSQ-7) and a small, lightweight radio repeater, RT-1175A/GSQ. I-REMBASS is fielded to the Special Operations Forces (SOF) for ground surveillance in deep penetration/denied area operations, in Low Intensity Conflict (LIC), and for surveillance of hostile activity behind enemy lines. Also, it is fielded to the RTSI for counterdrug operations. It detects moving targets and classifies them as personnel, wheeled vehicles or tracked vehicles. The system transmits real time reports on activity within the sensor's detection radius. The I-REMBASS utilizes either lithium or alkaline batteries and has a graphics software package in Ada for graphics display on an MS-DOS based lap top computer.

TRANSPORTATION CHARACTERISTICS / LIMITATIONS: 6' L x 6' W x 6' H (1 Set).

HISTORICAL BACKGROUND:

- May 92 Type Classified - Standard.
- Jun 92 Production Contract Award.
- Feb 93 Emergency Fielding.
- Aug 93 Final Buy-Out Award.
- Apr 95 Fielding to SOF completed.

REQUIREMENTS DOCUMENT: ROC approved Nov 86.

TYPE CLASSIFICATION: Standard approved 3QFY92.

RELEASEABLE TO SECURITY ASSISTANCE CUSTOMERS: Yes

EVENT SCHEDULE	FISCAL YEAR					
	97	98	99	00	01	02
	1 2 3 4	1 2 3 4	1 2 3 4	1 2 3 4	1 2 3 4	1 2 3 4
Competitive Production Award	4					

SYNOPSIS: I-REMBASS IS AN ALL WEATHER, DAY/NIGHT, PASSIVE, GROUND-BASED UNATTENDED SENSOR SYSTEM.

IEWS DIRECTORATE

NIGHT VISION INFRARED COMMON MODULES

SUBJECT OFFICER: Mr. Joe Lopresti,
DSN 992-8821
COMM 732/532-8821

ACQUISITION CATEGORY: IV
ACQUISITION PHASE: MS III Production/Deployment

PE & LINE #: Stock Funded

DESCRIPTION: The Night Vision Common Modules form the basic building blocks for many of the Army's Far Infrared Night Vision Systems such as the AH-64 Apache; Target Acquisition Designation Sight/Pilots Night Vision Sensor (TADS/PNVIS); M1 Abrams, Thermal Imaging System (TIS); M60A3, Tank Thermal Sight (TTS); Bradley Fighting Vehicle, Integrated Sight Unit (ISU); and the Manportable Common Thermal Night Sights (MCTNS). There are currently close to 40 different Common Modules fielded which fall into one of the following four major categories: Mechanical, Optical, Signal Conversion, and Electrical. The common modules are procured with Stock Funds Depot Repairable and are removed/replaced at Direct Support level. Configuration management is maintained by CECOM Night Vision/Electronic Sensors Directorate. Most of the technical data packages are fully competitive with some prequalification requirements for certain modules due to the state of the art technology.

COMMON MODULES

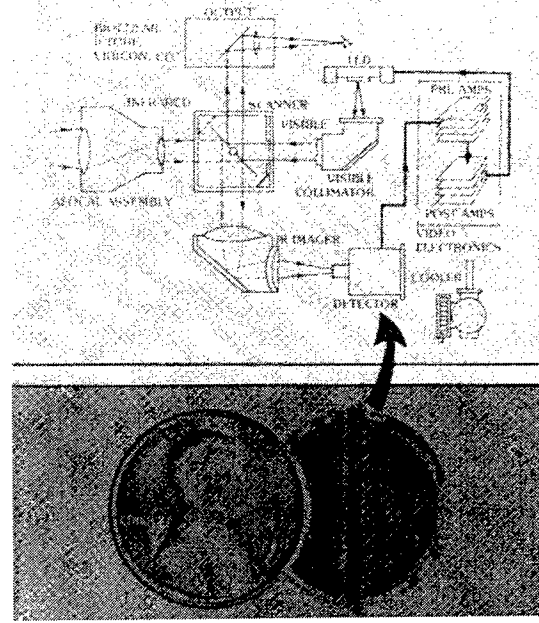

TRANSPORTATION CHARACTERISTICS / LIMITATIONS: None.

HISTORICAL BACKGROUND:

- 1974 Joint Logistics Commanders agree upon a Tri-Service policy of using Common Modules for Forward Looking Infrared (FLIR) development.
- 1976 DT-591/UA Detector/Dewar accepted as a Common Module.
- 1978 First Unit Equipped DT-591, DT-617, DT-594.
- 1984 Initiation of Optical Improvement Program by CECOM Night Vision and Electro-Optics Directorate.
- 1989 Night Vision and Electro-Optics Directorate approves First Article Test for Optically Improved Detector/Dewars.

REQUIREMENTS DOCUMENT: Required Operational Capability established at End Item Application/System.

TYPE CLASSIFICATION: Each Common Module has been Type Classified Standard.

RELEASEABLE TO SECURITY ASSISTANCE CUSTOMERS: No

EVENT SCHEDULE	FISCAL YEAR	97		98		99		00		01		02					
		QTR				1	2	3	4	1	2	3	4	1	2	3	4
Multiyear contract DAAB07-97-D-G033					2												
Multiyear contract DAAB07-97-D-G034					2												

SYNOPSIS: NIGHT VISION COMMON MODULES FORM THE BASIC BUILDING BLOCKS FOR MANY OF THE ARMY'S FAR INFRARED NIGHT VISION SYSTEMS.

RDEC

C2SID

C2SID

ADVANCED CONCEPTS TECHNOLOGIES II (ACT II) SATELLITE MOVEMENT TRACKING SYSTEMS (MTS) & RADIO FREQUENCY (RF) SENSOR TAGGED CONTAINERS/VEHICLES

PROJECT MANAGER: William Canfield,
 DSN 992-6419
 COMM 732/532-6419
 FAX: 732/427-3645
 E-Mail: canfield@doim6.monmouth.army.mil

ACQUISITION CATEGORY: IV
ACQUISITION PHASE: I

PE & LINE #: N/A

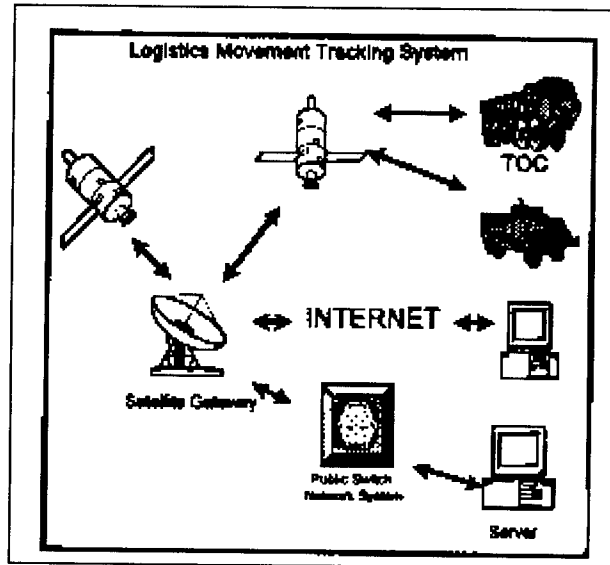

DESCRIPTION: The MTS system is primarily used for logistics tactical communications and real-time tracking of assets. The period of time from the transmission of a message and its reception by the end destination shall be between 3 and 5 seconds. The employed Commercial-Off-The-Shelf (COTS) technology shall provide improved management of the distribution channels, operations and overall efficiency of logistics management. The Contractor, Mobile Datacom, shall install communications equipment on government furnished Palletized Loading System (PLS) or Heavy Expandable Mobile Transport Truck (HEMTT) vehicles and on containers to be loaded onto these vehicles. The vehicles will be equipped with an MTS-Mobile Terminal, consisting of an integrated satellite mobile data terminal, RF tag interrogator, and ruggedized computer. Additionally, the MTS will be interfaced to the SAEJ1708 data bus which will permit vehicle engine data to be transmitted over the satellite. Information like the vehicle engine status or the contents of the RF Tagged containers shall be quickly displayed to enhance the Warfighters' understanding of his/her immediate situation. This improves situational awareness by vehicle operators.

TRANSPORTATION CHARACTERISTICS / LIMITATIONS: N/A

HISTORICAL BACKGROUND:

- 1995 CASCOM began fielding MTS to demonstrate the tactical utility of satellite based messaging and position reporting systems. It involved PLS vehicles with two-way mobile data terminals that had embedded Global Positioning System (GPS).
- 1997 ACT II CECOM contract provides MTS enhancements by (1) interfacing the MTS to the PLS engine computers, (2) replacing current dedicated QWERTY keyboards with a ruggedized computer, (3) incorporation of an RF Tag sensor for asset tracking, and (4) incorporation of a map display in every vehicle that not only shows the location of that vehicle, but also displays other MTS equipped vehicles.

REQUIREMENTS DOCUMENT: N/A

TYPE CLASSIFICATION: N/A

RELEASEABLE TO SECURITY ASSISTANCE CUSTOMERS: Yes

EVENT SCHEDULE	FISCAL YEAR		97		98		99		00		01		02	
	QTR		1	2	3	4	1	2	3	4	1	2	3	4
Contract Award			2											
HW/SW Demo					1									
Contract completion					2									

SYNOPSIS: THE MTS WILL ENHANCE LOGISTIC COMMAND, CONTROL, COMMUNICATIONS, AND INTELLIGENCE AUTOMATION TO THE WARFIGHTER VIA SATELLITE AND THE WORLD WIDE WEB (WWW).

C2SID

**CECOM/C2SID SUPPORT TO SOLDIER SYSTEMS
COMMAND (SSCOM), PROJECT MANAGER,
SOLDIER**

INDIVIDUAL SOLDIER'S COMPUTER/RADIO

PROJECT MANAGER: Douglas Wong,
DSN 987-3578
COMM 732/427-3578
FAX: 732/427-3645
E-Mail: wongdc@doim6.monmouth.army.mil

ACQUISITION CATEGORY: II
ACQUISITION PHASE: II

PE & LINE #: N/A

DESCRIPTION: CECOM supports the Soldier System Command with technical support and subject matter expertise to the Land Warrior (LW) project, which is managed by PM Soldier. The Land Warrior system is a weapons system with the capability for command, control and communications for the individual soldier. Land Warrior (LW) is an integrated, modular soldier system. It is designed to significantly enhance the soldier's ability to engage and defeat enemy targets while minimizing friendly casualties. All aspects of the soldier's ensemble have been designed to enhance lethality, survivability, command and control, mobility, and sustainment capabilities of individual soldiers and infantry units. The Land Warrior system consists of six subsystems: Weapons, Software Computer/Radio, Integrated Helmet Assembly, Protective Clothing and Individual Equipment and Wiring Harness. The Computer/Radio Subsystem (CRS), supported by C2SID, is a critical component to the integration and control of the other subsystems. Other CECOM organizations that technically support the PM Soldiers are : S&TCD, NVESD and the LRC.

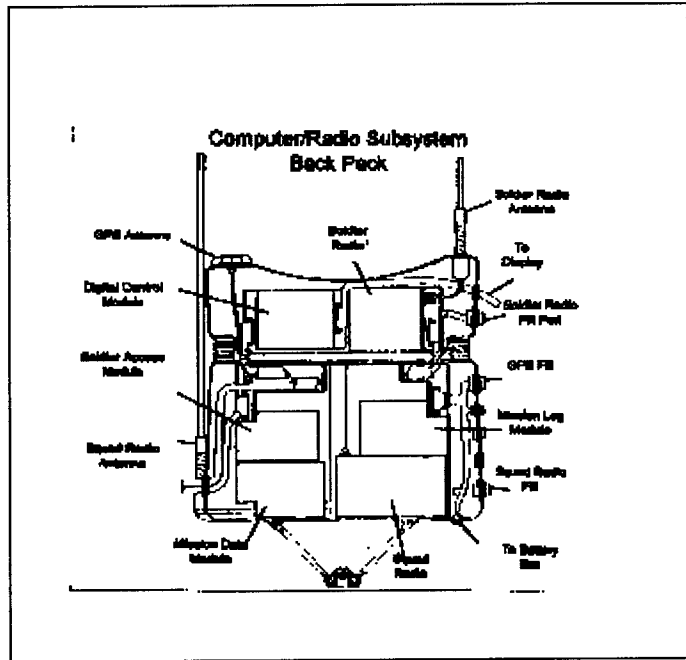

TRANSPORTATION CHARACTERISTICS / LIMITATIONS: Man-portable.

HISTORICAL BACKGROUND: C2SID support to Land Warrior Program

- 3Q94 Land Warrior Operational Requirements Document.
- 1Q95 Land Warrior RFP prepared/proposals evaluated.
- 2Q96 Land Warrior EMD Contract awarded.
- 3Q96 SW Systems Design Review.
- 1Q97 Early Operational Experiments.
- 2Q97 Hardware Preliminary Design Review.
- 3Q97 Software Preliminary Design Review.
- 4Q97 Land Warrior Critical Design Review.

REQUIREMENTS DOCUMENT: System is designed in response to user requirements established in approved Operational Requirements Document (ORD) for Land Warrior, 13 Apr 94.

TYPE CLASSIFICATION: N/A

RELEASEABLE TO SECURITY ASSISTANCE CUSTOMERS: No

EVENT SCHEDULE	FISCAL YEAR QTR	97				98				99				00				01				02			
		1	2	3	4	1	2	3	4	1	2	3	4	1	2	3	4	1	2	3	4				
Land Warrior Critical Design Review		4																							
Test Window (FDT&E, IOT&E)						1-----2																			
LRIP Decision										2															
Milestone III Full Production Decision														1											
First Unit Equipped														4											
Full Production Contract Award																		2							

SYNOPSIS: THE LAND WARRIOR SYSTEM WILL EXTEND AUTOMATED COMMAND, CONTROL, COMMUNICATIONS, AND INTELLIGENCE TO THE INDIVIDUAL SOLDIERS AT THE SQUAD LEVEL VIA A PORTABLE, MISSION-CONFIGURABLE, AND INTEGRATED COMPUTER/RADIO SUBSYSTEM.

C2SID

**BATTLE COMMANDERS WORKSTATION
SPEECH RECOGNITION TECHNOLOGY**

PROJECT MANAGER: Mr. Lockwood Reed,
DSN 995-2559
COMM 732/544-2559

ACQUISITION CATEGORY:
ACQUISITION PHASE: I Demo/Validation

PE & LINE #: A779 AV2534A

DESCRIPTION: Provide the user with a revolutionary synthesis of technologies which enable battlefield decision and interaction via voice with near human like understanding. Key technologies include: Speaker Independent, variable speech rate, noise robust speech recognition, Natural Language Processing, and Domain Specific/World Knowledge database processing.

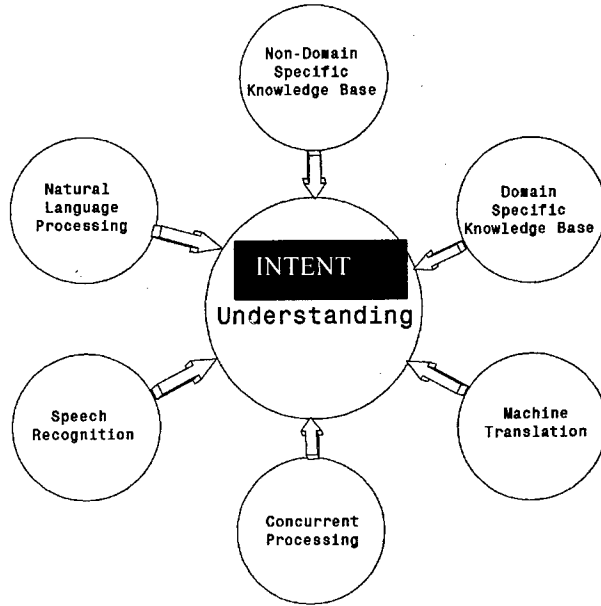

TRANSPORTATION CHARACTERISTICS / LIMITATIONS: N/A

REQUIREMENTS DOCUMENT: N/A

TYPE CLASSIFICATION: N/A

RELEASEABLE TO SECURITY ASSISTANCE CUSTOMERS: No

<u>EVENT SCHEDULE</u>	<u>FISCAL YEAR</u>															
	97		98		99		00		01		02					
	1	2	3	4	1	2	3	4	1	2	3	4				
	<u>QTR</u>															
Program Development					2											
Battlefield Visualization Phase I					2											
Applique Phase I					1											

SYNOPSIS: DEVELOP MULTIMODAL COMMAND UNDERSTANDING TO FACILITATE ACCESS OF C2 BATTLEFIELD INFORMATION.

C2SID

BATTLESPACE C2 DECISION AIDS (BCD)

PROJECT MANAGER: Dr. Israel Mayk,
DSN 987-4996
COMM 732/427-4996

ACQUISITION CATEGORY:
ACQUISITION PHASE:

PE & LINE: 62782 A779 AVC2PT

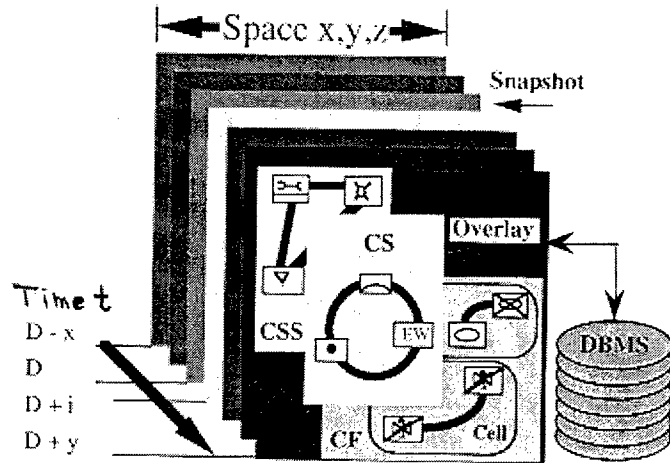

DESCRIPTION: BCD is a low-cost C2 development tool to test and evaluate existing and evolving Task Force XXI (TF XXI) and Army After Next (AAN) C2 decision-aids within a current or futuristic network-centric Joint Vision 2010 scenario. Under this effort, we demonstrate a scenario generator, animator and driver coupled to operational requirements analyses tools, a wargame and operational C2 Systems. The input to the scenario generator will include battlefield events from any feasible source. The output from the scenario driver will include operational messages and GPS positions. The particular wargame and C2 system interfaces are defined by the customer. Currently the C2 systems include the MCS and Applique software participating in the Battlefield Interoperability Program. An interface to the Eagle combat simulator will be developed in FY98. An interface to WARSIM2000 will be developed in the future. Horizontal collaborative planning between two battlefield functional areas will be demonstrated under dynamic conditions created by the wargame. The effectiveness of all technology demonstrations will be measured against established baselines.

TRANSPORTATION CHARACTERISTICS / LIMITATIONS: N/A

REQUIREMENTS DOCUMENT: N/A

TYPE CLASSIFICATION: N/A

RELEASEABLE TO SECURITY ASSISTANCE CUSTOMERS: Yes

SYNOPSIS: BCD IS A LOW-COST C2 DEVELOPMENT TOOL TO TEST AND EVALUATE EXISTING AND EVOLVING TASK FORCE XXI AND ARMY AFTER NEXT C2 DECISION-AIDS WITHIN A CURRENT OR FUTURISTIC NETWORK-CENTRIC JOINT VISION 2010 SCENARIO.

C2SID

BATTLESPACE COMMAND AND CONTROL (BC2)

PROJECT MANAGER: Allen Ponsini,
FAX: 732/532-0788
E-Mail: ponsini@doim6.monmouth.army.mil

ACQUISITION CATEGORY:
ACQUISITION PHASE: MS

PE & LINE #: 63772 D101

DESCRIPTION: The objective of the BC2-ATD is to develop, evolve and demonstrate, through simulation and experimentation with the user, technical solutions leading to a demonstrable (C2/BV) prototype that provides software tools supporting Consistent Battlespace Understanding; Forecasting, Planning and Resource Allocation; and Integrated Force Management for the Army Commander and Staff. These capabilities will be integrated into a C4I Systems Architecture at Battalion through Division that is interoperable with Corps/Joint/Allied assets.

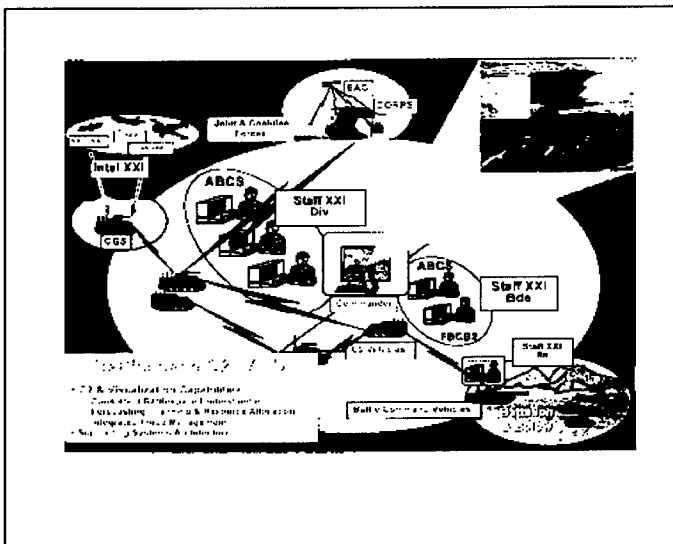

TRANSPORTATION CHARACTERISTICS / LIMITATIONS: None.

HISTORICAL BACKGROUND:

- Nov 96 Signed MOA with PM OPTADS supporting software module transition to MCS.
- Dec 96 Unified Endeavor with 18th ABC.
- Feb 97 Establish BC2 Oversight Integrated Process Team.
- Mar 97 TF XXI.

REQUIREMENTS DOCUMENT: None.

TYPE CLASSIFICATION: None.

RELEASEABLE TO SECURITY ASSISTANCE CUSTOMERS: Yes

EVENT SCHEDULE	FISCAL YEAR		97		98		99		00		01		02	
	QTR		1	2	3	4	1	2	3	4	1	2	3	4
Program Start			1											
Signed MOA with OPTADS			1											
TF XXI			2											
DIV XXI					1									
Software Transition to MCS					3				1					

SYNOPSIS: THE BC2-ATD IS CURRENTLY ON TRACK AS PLANNED AND IS ADDRESSING SOME OF THE ARMY'S PRIORITIZED C2/BV REQUIREMENTS.

C2SID

BATTLESPACE COMMANDER'S WORK STATION

PROJECT MANAGER: Dr. V.L. Rebbapragada,
 DSN 987-4029
 COMM 732/427-4029

ACQUISITION CATEGORY:
ACQUISITION PHASE:

PE & LINE: 62782 A779 AV2534

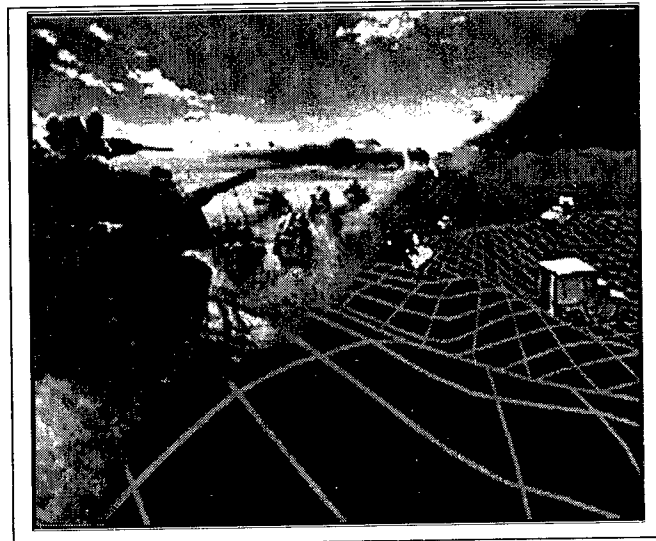

DESCRIPTION: The Battlespace Commander's Work Station (BCW), combined with "Battlespace C2 Decision Aides" and "Speech Recognition Technology" combine to form the 6.2 Battle Planning STO#IV.G.06. BCW will integrate emerging technologies to demonstrate concepts which significantly enhance battlespace awareness and enable commanders and their staffs to electronically interface to the battlespace in an effective and intuitive manner. Technologies developed/integrated include: computer/graphics hardware and software to support real-time 3D rendering of information; hardware and algorithms to facilitate natural human/machine interfaces [natural language (NL), touch and gestures, large screen displays and voice control]; and software to implement battle views, route planning, definition of force structure, and overlay of control measures. BCW is a technology feed to: Force XXI and follow-on Division and Corps AWE's, XVIII Airborne Corps AWE's, Battlespace Command and Control ATD, Rapid Battlefield Visualization ACTD, and the following Information Systems and Technology (IST) Defense Technology Objectives (DTO's) - Consistent Battlespace Understanding; Forecasting, Planning and Resource Allocation; and Integrated Force Management.

TRANSPORTATION CHARACTERISTICS / LIMITATIONS: N/A

HISTORICAL BACKGROUND:

REQUIREMENTS DOCUMENT: N/A

TYPE CLASSIFICATION: Battlefield Visualization Requirement TRADOC PAM 525-70, Master Plan.

RELEASEABLE TO SECURITY ASSISTANCE CUSTOMERS: Yes

EVENT SCHEDULE	FISCAL YEAR					
	97	98	99	00	01	02
QTR	1 2 3 4	1 2 3 4	1 2 3 4	1 2 3 4	1 2 3 4	1 2 3 4
Exploratory Development Planning, Decision Aids, Integration						4

SYNOPSIS: THE FOCUS IS ON THE COMMANDERS INTERFACE TO THE BATTLESPACE AND THE EMBEDDED SOFTWARE TOOLS WHICH ALLOW THE COMMANDER AND HIS STAFF TO COLLABORATE ELECTRONICALLY TO PLAN, REHEARSE, EXECUTE, AND MONITOR THE BATTLE IN A RAPID AND EFFECTIVE MANNER.

C2SID

DIFFERENTIAL GPS (DGPS) TECHNOLOGY

PROJECT MANAGER: Mr. Stephen P. Ahrens,
DSN 987-3894
COMM 732/427-3894

ACQUISITION CATEGORY: N/A
ACQUISITION PHASE: I Demo/Validation

PE & LINE: 62782 A779

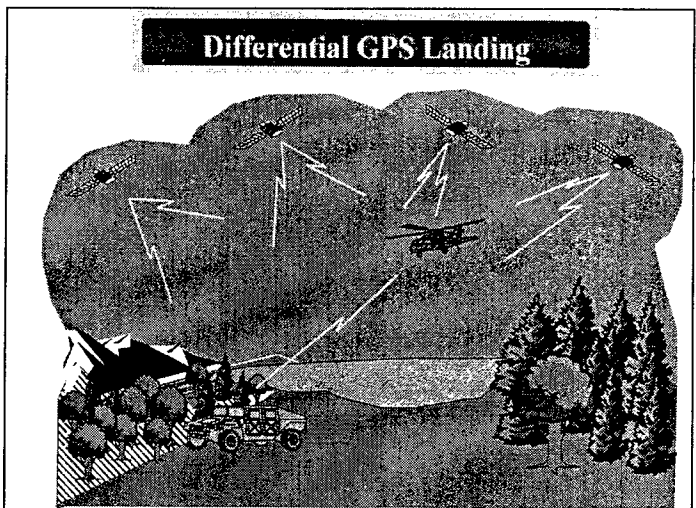

DESCRIPTION: The Differential GPS Technology effort is being pursued to determine if Differential GPS techniques can be applied to precision approach and landings in tactical environments. C2SID is developing a Database of Precision Approach data. The data will be based on multiple sensors, GPS Y code, and the use of both L1 and L2 frequencies. The data will allow C2SID to evaluate the effects of temporary outages caused by interference/jamming, obstructions, and the effects of multipath/skin effect. The Database can then be used to determine how multi-sensor aiding will increase performance, robustness, and continuity of function, and how integrity schemes will increase the level of safety during a precision approach.

TRANSPORTATION CHARACTERISTICS / LIMITATIONS: None

HISTORICAL BACKGROUND: The Army has long had a need for a precision approach capability during day/night all weather operations in a tactical environment. This need is particularly important at Brigade and other forward landing zones where other systems can not be deployed because of their size and weight.

REQUIREMENTS DOCUMENT: Joint Mission Needs Statement for Precision Approach and Landing Capability. STO III.E.08 Navigation Technology Integration into Digitized Battlefield.

TYPE CLASSIFICATION: None

RELEASEABLE TO SECURITY ASSISTANCE CUSTOMERS: No

EVENT SCHEDULE	FISCAL YEAR		98	99	00	01	01	02
	QTR		1 2 3 4	1 2 3 4	1 2 3 4	1 2 3 4	1 2 3 4	1 2 3 4
Conduct Differential GPS flight test			1--2					
Develop multiple-sensor Kalman filters			3--4					
Evaluate multipath/skin effect data				1--2				
Conduct blockage/jamming flight test				2--3				
Complete multi-sensor matrix/D Base				3--4				

SYNOPSIS: THE DIFFERENTIAL GPS TECHNOLOGY EFFORT WILL DETERMINE IF DGPS TECHNIQUES CAN BE APPLIED TO PRECISION APPROACH AND LANDINGS DURING DAY/NIGHT ALL WEATHER OPERATIONS AT REMOTE TACTICAL LANDING ZONES.

C2SID

NAVIGATION TECHNOLOGY

PROJECT LEADER: Mr. Paul M. Olson,
 DSN 987-3912
 COMM 732/427-3912

ACQUISITION CATEGORY: N/A
ACQUISITION PHASE: MS I Demonstrate/Validation

PE & LINE: PE 62782 A779 AV 2031/2031A

DESCRIPTION: The purpose of this program is to develop robust navigation technology and system concepts to lessen reliance on external navigation aids such as GPS. The approach will employ self-contained, RF and electro-optic sensors for correlation to terrain and feature databases in an architecture which supports soldier, ground and airborne platforms. Advantage will be taken of new visionic concepts and imagery databases. Highly robust navigation information correlated with sensor and database technology is required to support Command and Control (C2) functions, including Information Warfare, Situation Awareness, C2 on the Move and unattended Precision Approach & Landing. Development of a correlation scheme combining available navigation, video, imagery and terrain data will provide a cohesive and consistent picture of the battlefield to the commander and the individual soldier. Enhancement of GPS user capabilities will continue with the application of advanced filter, low power clock and antenna technologies. Development/evaluation of Low Probability of Intercept (LPI) Navigation Sensors (Doppler & RAD ALT) will be conducted.

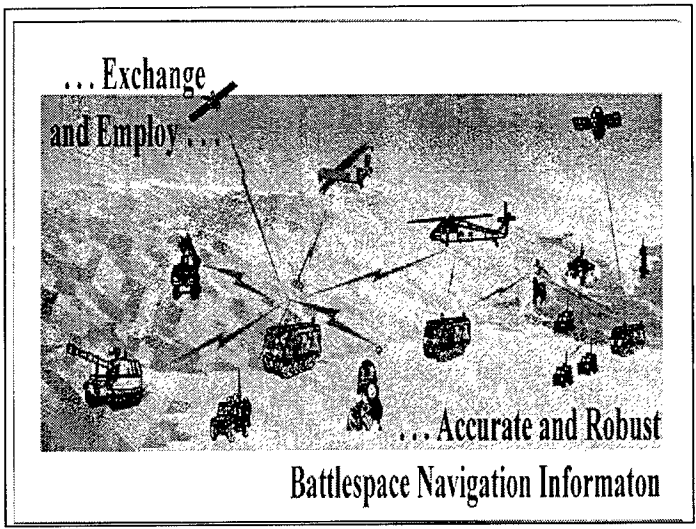

TRANSPORTATION CHARACTERISTICS / LIMITATIONS: None.

HISTORICAL BACKGROUND: Continually evolving program striving to meet advanced requirements for precision navigation and positioning.

REQUIREMENTS DOCUMENT: STO III. E.08; Navigation Technology Integration for the Digitized Battlefield.

TYPE CLASSIFICATION: N/A.

RELEASEABLE TO SECURITY ASSISTANCE CUSTOMERS: Yes

EVENT SCHEDULE	FISCAL YEAR	98		99		00		01		02		03	
		1	2	3	4	1	2	3	4	1	2	3	4
	QTR	1	2	3	4	1	2	3	4	1	2	3	4
STO III.E.08 Demonstration		-----	3										
Computer Simulation		-----	3										
System Definition		-----		----	2								
Post Processed Data Demo						1							
System Config/HW Demos						2-----	-----	-----	-----	-----	-----	-----	-----3

SYNOPSIS: APPLY ADVANCED SENSOR AND INTEGRATION TECHNOLOGY TO IMPROVE NAVIGATION SYSTEM ACCURACY BY ONE ORDER OF MAGNITUDE IN ALL ENVIRONMENTS. IN A PROPERLY REGISTERED DIGITAL MAP DATABASE.

C2SID

**RAPID FORCE PROJECTION INITIATIVE
COMMAND & CONTROL (RFPI-C2)**

PROJECT MANAGER: Ms. Gayle Grant,
DSN 987-3928
COMM 732/427-3928

ACQUISITION CATEGORY: N/A
ACQUISITION PHASE: MS I Demo/Validation

PE & LINE: 63772 D101

DESCRIPTION: The Rapid Force Projection Initiative will demonstrate Enhanced Capabilities which address the strategy of Close Combat Light with respect to the rapidly deployable force. The C2 portion of this program will demonstrate the integration of rapid force projection remote scout and sensor reconnaissance information into the Battlespace C2 concept, providing commanders with the ability to integrate data into the overall battlefield picture, set target priorities, determine target weapon pairings, and perform target handover to non line-of-sight, air attack, or close weapon systems. Demonstrations will encompass the data links required to transport targeting data from remote sensors to a central point, and the ability to redistribute the correlated targeting data to a decision point and to various weapon platforms which would bring fire on given targets. Various transmission technologies will be investigated: wide band data links, packet techniques, bandwidth compression, and alternate frequency bands.

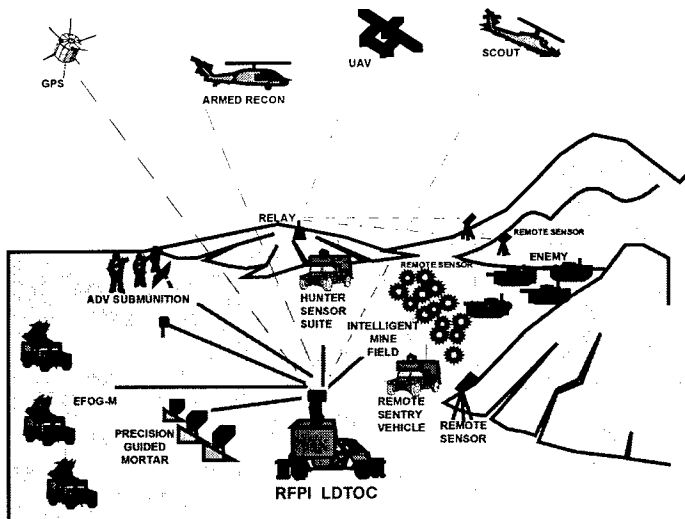

APPROACH: The RFPI C2 Technical Demonstration will deliver a Light Digital TOC Simulator (LDTOC SIM), a Light Digital TOC (LDTOC) and the appropriate C2 enhancement and communications processing software. The initial build of the LDTOC SIM will be used during the DBBL BLWE to be held at Ft. Benning during the 1st Qtr of 1997. The LDTOC SIM with improvements made as a result of the BLWE will be used as the blueprint for the LDTOC. After a 4th Qtr 1997 Proof-of-Principle exercise in which both the LDTOC SIM and the LDTOC will participate, both systems will participate in the RFPI Advanced Concept Technical Demonstration (ACTD), a 3rd Qtr 1998 full field exercise involving XVIII Abn. Corps units. Following the ACTD the LDTOC SIM will remain at DBBL while the LDTOC will be refurbished and remain with the exercise unit to function as that unit's go-to-war TOC for a two year evaluation period, ending FY00.

TRANSPORTATION CHARACTERISTICS / LIMITATIONS: RFPI LDTOC is air transportable (C130, C141, C5A) and sling loadable.

REQUIREMENTS DOCUMENT: STO 111.H.05 Rapid Force Projection Initiative (RFPI) C2 for thrust 5.

TYPE CLASSIFICATION: N/A.

RELEASEABLE TO SECURITY ASSISTANCE CUSTOMERS: No

<u>EVENT SCHEDULE</u>	FISCAL YEAR	97	98	99	00	01	02
		1 2 3 4	1 2 3 4	1 2 3 4	1 2 3 4	1 2 3 4	1 2 3 4
Battle Lab Warfighting Experiment (BLWE)		2					
Virtual Rehearsal		4					
Proof of Principle			1				
Advanced Concept Technical Demonstration (ACTD)			4				
Refurbishment Period			4--	-----3			
Residual Leave Behind Period				3-----	-----3		

SYNOPSIS: RAPIDLY DEPLOYABLE COMMAND & CONTROL SYSTEM FOR CLOSE COMBAT LIGHT FORCES DURING EARLY ENTRY AND SUSTAINED OPERATIONS.

C2SID

SOLDIER INDIVIDUAL POWER

PROJECT MANAGER: Mr. Richard Jacobs,
DSN 654-2637
COMM 703/704-2637

ACQUISITION CATEGORY: Non-Major
ACQUISITION PHASE: Concept Exploration

PE & LINE #: 62705 H11

DESCRIPTION: This program is directed at demonstrating small PEM Fuel Cell Power Sources in the range of 50-150 Watts. These demonstrations will take place in FY96 and FY98 under Science and Technology Objective (STO) IVJ.04, "Soldier Individual Power". Fuel Cell Power sources offer silent, efficient, lightweight power for applications in personnel power, sensors, battery charging, communications equipment and other similar system. Fuel Cells work by electrochemical reaction in which the energy of a fuel and an oxidant are transformed into DC current.

TRANSPORTATION CHARACTERISTICS / LIMITATIONS:
Unknown

HISTORICAL BACKGROUND:

- FY94 Revised STO due to funding loss.
- FY95 Contract Award for FY96 Demonstration.
- FY96 Technical Demonstration.

REQUIREMENTS DOCUMENT: Draft Mission Needs Statement for "Soldier Power System".

TYPE CLASSIFICATION: N/A

RELEASEABLE TO SECURITY ASSISTANCE CUSTOMERS: No

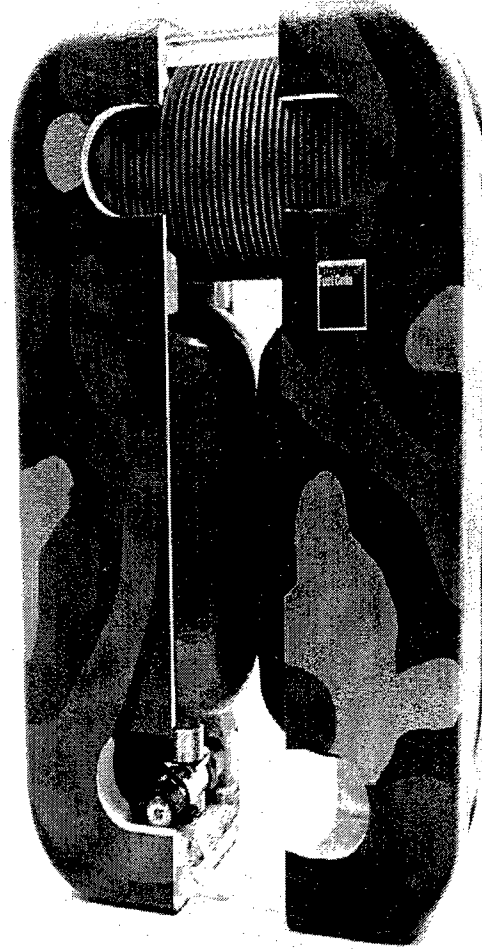

<u>EVENT SCHEDULE</u>	<u>FISCAL YEAR</u> QTR	97	98	99	00	01	02
		1 2 3 4	1 2 3 4	1 2 3 4	1 2 3 4	1 2 3 4	1 2 3 4
Contract Award		2					
Individual Power Technical Demonstration			4				

SYNOPSIS: DEMONSTRATE SMALL PEM FUEL CELL POWER SOURCES FOR VARIOUS MILITARY APPLICATIONS UNDER STO IVJ.04, "SOLDIER INDIVIDUAL POWER".

C2SID

TACTICAL ELECTRIC POWER

PROJECT MANAGER: Ms. Selma Nawrocki Matthews,
DSN 654-3377

ACQUISITION CATEGORY: 6.2
ACQUISITION PHASE: MSO

PE & LINE #: 0602705A AH11 (Formerly AH20)

DESCRIPTION: The Tactical Electric Power (Man Portable Generator) program is a Technology Base funded project which develops and demonstrates efficient, signature suppressed,

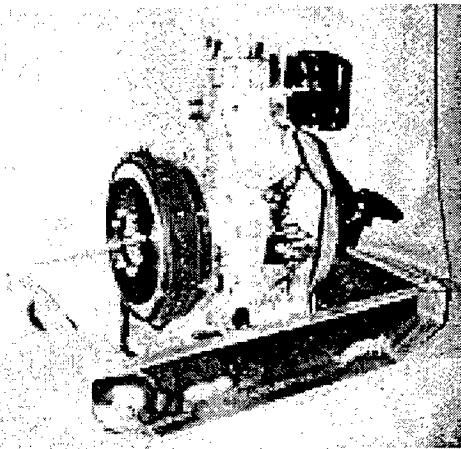

electronically controlled diesel engine driven generator sets small and light enough to be man portable/man handleable (500 W @ 30lb. - 3.0 kW @ 150 lb. And capable of meeting the operational and performance requirements of the 21st Century battlefield). The engines of these power units will be required to produce between 1 and 7 horsepower and to start and operate on logistically available fuel (JP-8 and DF-2). Engines (1-3 hp) and Permanent Magnet (PM) alternators (1 kW, 28 Vdc) have been developed and demonstrated ('95 STO). These FY95 results were leveraged into the FY97 phase of this STO. Additional development and integration (FY97 STO) of state of the art commercial high speed diesel engines, PM alternators, and high frequency power electronics will result in a lighter, more reliable 150 pound (dry weight) signature suppressed, electronically controlled 3 kW, 120 Vac diesel engine driven generator set that can survive in hostile, extreme environments. Advances in Power Technology allow for increased energy and power density and conversion efficiency (high speed engines with modified combustion schemes, high speed permanent magnet alternators, power electronics) and for increased efficiency and mechanical/structural integrity (lightweight construction techniques). Emphasis is placed on logistic fuels, quiet operations, improved mission effectiveness, and enhanced near term readiness. The Man Portable Generators may be used by light forces, including Special Operation Forces, world wide for tactical power uses and by USMC, Joint Project Office for ground support of Unmanned Aerial Vehicles, and NSA. They can also be used in "other than combat" mission scenarios and "quality of life" applications such as maintenance power supply, portable hand tools, battery charging, jump starting vehicles, electrical lighting, tactical operations centers disaster relief operations, communications, remote sensors, and robotic movers.

TRANSPORTATION CHARACTERISTICS / LIMITATIONS: One or two man portable depending on power rating.

HISTORICAL BACKGROUND:

- 1993/4 Developed JP-8 fuel burning, spark ignition engine prototypes (0.7 and 3.0 hp).
- 1994 Developed permanent magnet lightweight alternators (1 kW, 28 Vdc).
- 1995 Demonstrated a 13 lbs, 500 Watt engine driven generator set prototype.
Demonstrated middle distillate fuel conditioning, ignition, and combustion enhancing technologies in modified lightweight 3.0 hp engines suitable for integration with high speed permanent magnet alternators rated at 1 kW at 28 Vdc.
- 1996 Developed a 3 kW, 28 Vdc PM alternator weighing 18 pounds (74% decrease in weight, System Efficiency=94%).
Demonstrated R&D mule (3 hp lightweight spark ignited engines and 1 kW, 28 Vdc PM alternators) components.

REQUIREMENTS DOCUMENT: None.

TYPE CLASSIFICATION: None.

RELEASEABLE TO SECURITY ASSISTANCE CUSTOMERS: Yes

EVENT SCHEDULE	FISCAL YEAR QTR	97		98		99		00		01		02	
		1	2	3	4	1	2	3	4	1	2	3	4
Update Design 3 kW Generator Set		1-2											
Conduct Component/Subsystem Tests		1-2											
Fabricate Prototype		1-3											
Perform Noise/IR Testing		3-4											
Perform Durability Testing		3-4											
Demonstrate FY97 STO		4											

SYNOPSIS: THE TACTICAL ELECTRIC POWER WILL DEMONSTRATE GENERATOR SETS SMALL AND LIGHT ENOUGH TO BE MAN PORTABLE AND MAN HANDLEABLE.

C2SID

VEHICLE IN-LINE GENERATOR

PROJECT MANAGER: Mr. Lee Anderson,
DSN 654-3370
COMM 703/704-3370

ACQUISITION CATEGORY: 6.2
ACQUISITION PHASE: MSO

PE & LINE #: Small Business Innovative Research Topic
A95-084

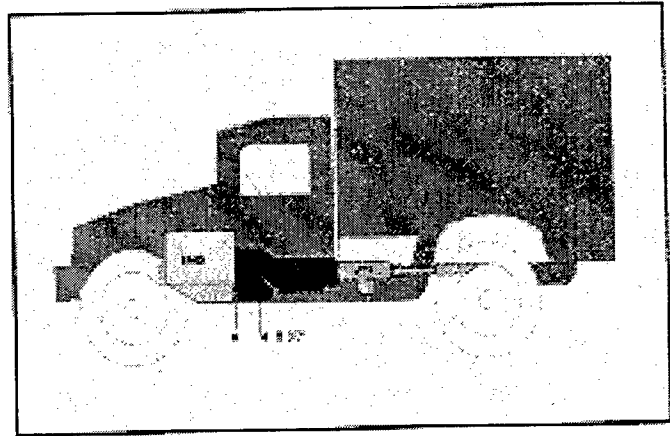

DESCRIPTION: The Vehicle In-Line Generator Program is an innovative R&D effort intended to demonstrate a 10 kW, 3 phase, AC alternator mounted in the drive train of a tactical vehicle between the engine and transmission. This configuration provides the vehicle with the ability to produce electric power without interfering with its primary mission of transporting cargo, personnel or tactical systems. By using the vehicle's engine as the prime mover for power, along with locating the alternator in the drive train, the electrical generating system becomes virtually invisible to the routine operation of the vehicle.

A Vehicle In-Line Generator dedicated to a tactical system can provide the electrical power necessary to meet the mission requirements without the need for a towed power unit. Diesel Engine Driven (DED) Generator Sets provide very reliable electric power for many military systems, however, many of today's tactical systems are designed for rapid deployment and high mobility and are configured on the High Mobility Multipurpose Wheeled Vehicle (HMMWV). The HMMWV is a light tactical vehicle, therefore, these systems often push the vehicle to its weight limit. This makes the HMMWV a prime candidate for this new and innovative technology.

Many of the present HMMWV mounted systems are either equipped with an auxiliary power unit (APU), weighing over 400 pounds, or tow a trailer mounted DED power unit weighing over 4,000 pounds. These options not only increase system weight, they also occupy precious space and/or dramatically increase system size. The Vehicle In-Line Generator concept decreases system size and weight and therefore improves mobility, and speeds the deployment of tactical systems.

TRANSPORTATION CHARACTERISTICS / LIMITATIONS:

HISTORICAL BACKGROUND:

- 1992 Developed and demonstrated the Vehicle In-Line Generator concept in a 2-1/2 ton military cargo truck.
- 1993 Initiation of a program to develop and prove the technology in a High Mobility Multipurpose Wheeled Vehicle (HMMWV).

REQUIREMENTS DOCUMENT: N/A

TYPE CLASSIFICATION: N/A

RELEASEABLE TO SECURITY ASSISTANCE CUSTOMERS: Yes

<u>EVENT SCHEDULE</u>	<u>FISCAL YEAR</u> QTR	97				98				99				00				01				02			
		1	2	3	4	1	2	3	4	1	2	3	4	1	2	3	4	1	2	3	4	1	2	3	4
Phase II Contract Award		3																							
Phase II Contract		3----				-----				--1															
System Integration						3----				--1															
System Evaluation						3----				--1															
System Delivery										1															

SYNOPSIS: DEVELOP THE CAPABILITY FOR IN-LINE GENERATORS TO BE USED AS A PRIMARY SOURCE OF ELECTRICAL POWER IN TACTICAL SITUATIONS.

I2WD

**THIS SECTION IS
NOT AVAILABLE**

NVESD

NVESD

ADVANCED ELECTRONIC WARFARE (EW) SENSORS

PROJECT MANAGER: Ray Irwin,
 DSN 987-2493
 COMM 732/427-2493
 E-Mail: rirwin@nvl.army.mil

ACQUISITION CATEGORY:
ACQUISITION PHASE: MS

PE & LINE #: 62270/A442

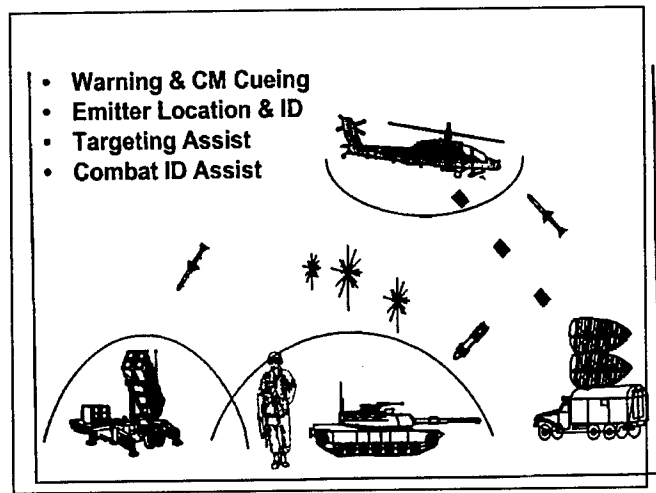

DESCRIPTION: This project will develop HTI capable multi-spectral missile, laser and radar warning sensors with precision angle of arrival, primarily to control and direct countermeasures, but with capability for enhanced situational awareness, target cueing, and combat ID assist.

TRANSPORTATION CHARACTERISTICS / LIMITATIONS:

HISTORICAL BACKGROUND:

REQUIREMENTS DOCUMENT:

TYPE CLASSIFICATION:

EVENT SCHEDULE	FISCAL YEAR				FISCAL YEAR				FISCAL YEAR				FISCAL YEAR				FISCAL YEAR			
	QTR				QTR				QTR				QTR				QTR			
	1	2	3	4	1	2	3	4	1	2	3	4	1	2	3	4	1	2	3	4
Develop LO Multi Octave antennas								1-----4												
Precision Emitter ID Geolocation targeting								1-----4												
Detection algorithms											2-----4									
Air/Ground Prototype detector											3-----1									
Multi-spectral Integration and Test											4-----4									

SYNOPSIS: PROVIDE HTI CAPABLE MULTI-SPECTRAL MISSILE, LASER AND RADAR WARNING SENSORS FOR ENHANCED SITUATION AWARENESS, TARGET CUEING, AND COMBAT ID ASSIST.

NVESD

ADVANCED EOIR COUNTERMEASURES

PROJECT MANAGER: Dr. Joe O'Connell,
 DSN 987-4870
 COMM 732/427-4870
 FAX: DSN 987-3225
 E-Mail: oconnell@nvl.army.mil

ACQUISITION CATEGORY: N/A
ACQUISITION PHASE: 0

PE & LINE #: 62270/A442

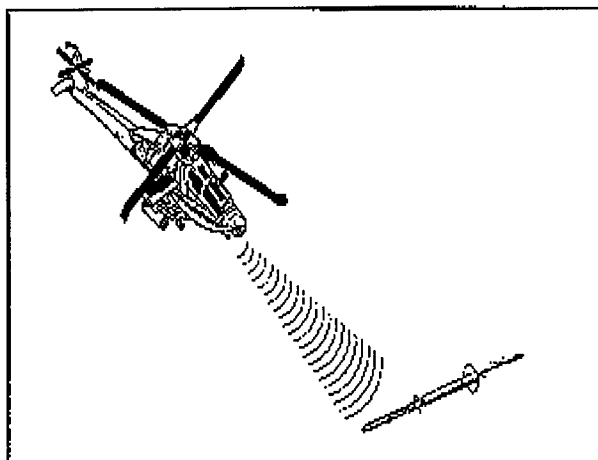

DESCRIPTION: This program will develop multifunction countermeasures to protect Army aircraft and ground vehicles from advanced EO/IR guided missiles and smart munitions. Technology development will focus on key components such as sources/optics, pointing/tracking devices, missile plume and laser sensors and include jamming techniques against passive homing and beam rider missiles.

TRANSPORTATION CHARACTERISTICS / LIMITATIONS:

HISTORICAL BACKGROUND:

REQUIREMENTS DOCUMENT:

TYPE CLASSIFICATION:

<u>EVENT SCHEDULE</u>	<u>FISCAL YEAR</u>																							
	97				98				99				00				01				02			
	1	2	3	4	1	2	3	4	1	2	3	4	1	2	3	4	1	2	3	4	1	2	3	4
Diode Laser								4																
Imaging Seeker CM				4																				
IR Missile Analysis I				3																				
IR Missile Analysis II				3				4																

SYNOPSIS: DEVELOP MULTI-FUNCTION COUNTERMEASURES TO PROTECT AIRCRAFT AND GROUND VEHICLES FROM ADVANCED EO/IR GUIDED MISSILES AND SMART MUNITIONS.

NVESD

ADVANCED FOCAL PLANE ARRAY

PROJECT MANAGER: Stuart Horn,
 DSN 654-2025
 COMM 703/704-2025
 FAX: DSN 654-1705
 E-Mail: shorn@nvl.army.mil

ACQUISITION CATEGORY: N/A
ACQUISITION PHASE: 0

PE & LINE #: 62709/DH95

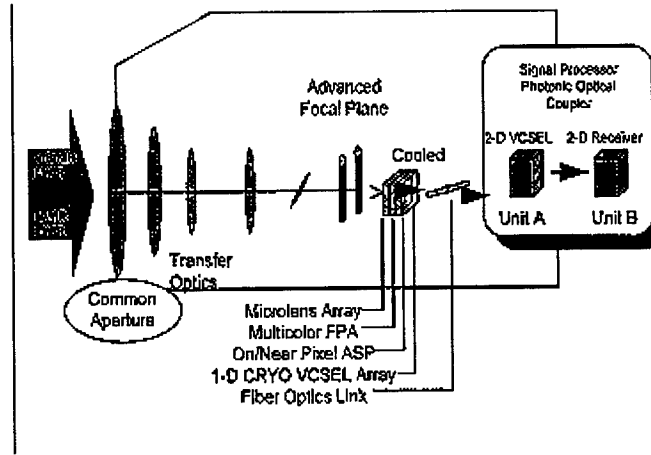

DESCRIPTION: This program will develop an advanced generation of IR imaging sensors which use large staring FPAs which allow smart temporal and multi-spectral signal processing. Technology will be developed to provide TV quality imagers in the 3-5 micron and 8-12 micron bands including practical non-uniformity correction.

TRANSPORTATION CHARACTERISTICS / LIMITATIONS:

HISTORICAL BACKGROUND:

REQUIREMENTS DOCUMENT:

TYPE CLASSIFICATION:

EVENT SCHEDULE	FISCAL YEAR QTR	97	98	99	00	01	02
		1 2 3 4	1 2 3 4	1 2 3 4	1 2 3 4	1 2 3 4	1 2 3 4
Modeling and Analysis		1-----	-----	---2			
Multi-spectral sensing		1-----	-----	-----	---4		
Demonstration large FPA			4--	-----	-----	--1	

SYNOPSIS: DEVELOP LARGE STARING FPAs IN BOTH MULTI-SPECTRAL AND HYPER-SPECTRAL ARCHITECTURES WITH SMART ROICs AND WEAPONS FEEDBACK CONTROL TO OPTIMIZE TARGET ACQUISITIONS.

NVESD

ADVANCED HELICOPTER PILOTAGE (AHP) TD

PROJECT MANAGER: Mr. Trang Bui,
DSN 654-1369
COMM 703/704-1369
E-Mail: tbui@nvl.army.mil

ACQUISITION CATEGORY: N/A
ACQUISITION PHASE: MS 0 Concept Explor./Definition

PE & LINE: PE 63710 / DK86

**Turret Mounted 2nd Gen FLIR
12 Camera
Phase 1 FOV
30 x 50**

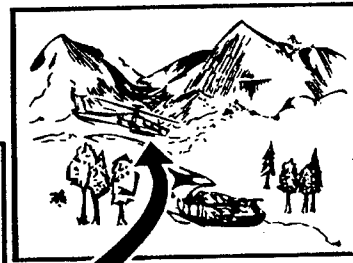
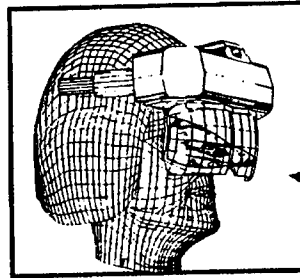

**High Resolution HMD
Phase 2 FOV
40 x 80**

DESCRIPTION: AHP will develop and demonstrate advanced night vision pilotage sensors and Helmet Mounted Display (HMD) technology for night/adverse weather helicopter pilotage. AHP Phase I will develop second Generation FLIR, and a HDTV Image Intensified Camera with a wide field of view, and improves signal processing. Phase II will demonstrate robust night vision technology to provide a significant reduction in pilot cognitive and physical work load.

TRANSPORTATION CHARACTERISTICS / LIMITATIONS: None.

HISTORICAL BACKGROUND:

REQUIREMENTS DOCUMENT: N/A

TYPE CLASSIFICATION: N/A

EVENT SCHEDULE	FISCAL YEAR QTR	97	98	99	00	01	02
		1 2 3 4	1 2 3 4	1 2 3 4	1 2 3 4	1 2 3 4	1 2 3 4
Flight Demo		-----3					
Phase II HMD		-----4					
AHP Phase II			-----2				

SYNOPSIS: NIGHT PILOTAGE SENSORS AND HELMET MOUNTED DISPLAYS WHICH INCREASE BATTLEFIELD COMPREHENSION DURING THE DAY, NIGHT, AND IN ADVERSE WEATHER HELICOPTER TERRAIN FLIGHT.

NVESD

ADVANCED MINE DETECTION SENSORS

PROJECT MANAGER: Robert Barnard,
 DSN 654-1066
 COMM 703/704-1066
 FAX: DSN 654-1041
 COMM: 703/704/1041

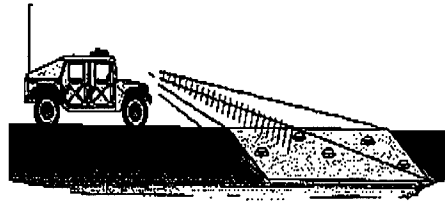

ACQUISITION CATEGORY: N/A
ACQUISITION PHASE: 0

PE & LINE #: 62712/AH24

DESCRIPTION: This program will evaluate enhancements to forward looking radar and integrate this technology fusion for testing against anti-tank and anti-personnel mines. Advanced FLIR and SLR technologies will be evaluated for increased stand off detection. This program will demonstrate multi-sensor ability to detect mines remotely at 5-20 Km/hr.

TRANSPORTATION CHARACTERISTICS / LIMITATIONS:

HISTORICAL BACKGROUND:

REQUIREMENTS DOCUMENT:

TYPE CLASSIFICATION:

<u>EVENT SCHEDULE</u>	FISCAL YEAR QTR	97				98				99				00				01				02			
		1	2	3	4	1	2	3	4	1	2	3	4	1	2	3	4	1	2	3	4	1	2	3	4
Passive MMW studies		1							4																
Sensor Fusion (I)			4										4												
Sensor Fusion (II)												4													4
UWB Radar						1																			4
Acoustic/Seismic										1															4
Integration and Demonstration																		1							4

SYNOPSIS: EXPLORE SENSOR PROCESSING AND FUSION TECHNIQUES TO IMPROVE MINE DETECTION CAPABILITIES FOR APPLICATION TO VEHICLE MOUNTED AND HAND-HELD MINE DETECTION SYSTEMS.

NVESD

ADVANCED OPTICS AND DISPLAY APPLICATIONS

PROJECT MANAGER: William Markey,
 DSN 654-1306
 COMM 703/704-1306
 FAX: DSN 654-1387
 E-Mail: wmarkey@nvl.army.mil

ACQUISITION CATEGORY: N/A
ACQUISITION PHASE: 0

PE & LINE #: 62709/DH95

DESCRIPTION: Develop and demonstrate a family of optics, sensors and display technologies for future head mounted high resolution display/sensor systems.

TRANSPORTATION CHARACTERISTICS / LIMITATIONS:

HISTORICAL BACKGROUND:

REQUIREMENTS DOCUMENT:

TYPE CLASSIFICATION:

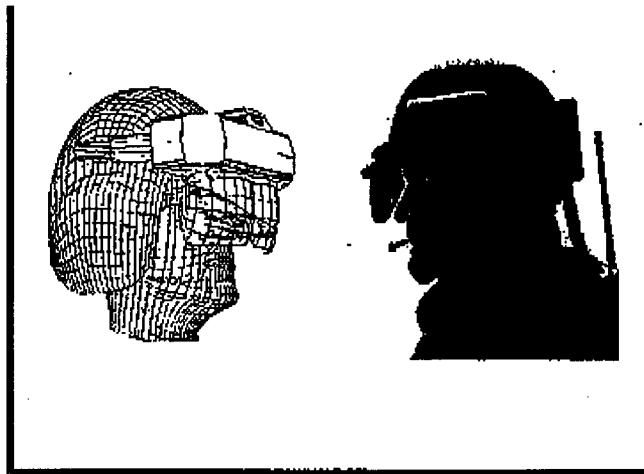

EVENT SCHEDULE	FISCAL YEAR QTR	97	98	99	00	01	02
		1 2 3 4	1 2 3 4	1 2 3 4	1 2 3 4	1 2 3 4	1 2 3 4
AI2 display		-1					
Modeling		-2					
Display evaluation		-4					
Sensor evaluation		-4					
Optics		-4					

SYNOPSIS: DEVELOP COMMON MODULE OPTICS, DISPLAYS, AND SENSORS FOR HELMET MOUNTED VISION SYSTEMS APPLICABLE TO INFANTRY, ARMOR AND AVIATION.

NVESD

ADVANCED RF COUNTERMEASURES

PROJECT MANAGER: Ray Irwin,
 DSN 987-4589
 COMM 732/427-4589
 FAX: DSN 987-3225

ACQUISITION CATEGORY: N/A
ACQUISITION PHASE: Concept Exploration & Definition

PE & LINE #: 62270/A442

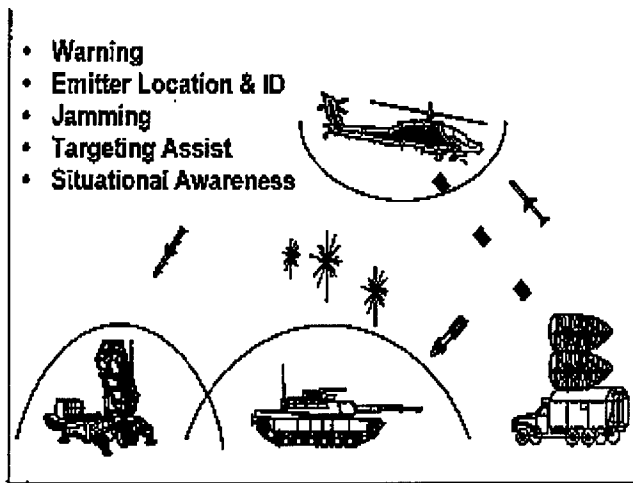

DESCRIPTION: Advanced RF CM will demonstrate jamming techniques against single and multi-spectral top attack smart munitions. This program will also demonstrate RF sensors and ECM modulators with the capability to locate, deceive, and jam monopulse and phased array radars from UHF through millimeter wave.

TRANSPORTATION CHARACTERISTICS / LIMITATIONS:

HISTORICAL BACKGROUND:

REQUIREMENTS DOCUMENT:

TYPE CLASSIFICATION:

EVENT SCHEDULE	FISCAL YEAR		97		98		99		00		01		02	
	QTR		1	2	3	4	1	2	3	4	1	2	3	4
SIL Enhancements														
Monopulse ECM														
Phased Array ECM														
Precision Geolocation			1											
Multi-spectral sensor			1											
Fiber optic remote antenna					1									

SYNOPSIS: MULTI-FUNCTIONAL SURVIVABILITY EQUIPMENT THAT CAN PERFORM WARNING SITUATIONAL AWARENESS, COUNTERMEASURES, TARGETING AND COMBAT ID ASSIST FOR AIRCRAFT, GROUND VEHICLES, AND DISMOUNTED SOLDIER.

NVESD

ADVANCED SIGNATURE MANAGEMENT & DECEPTION

PROJECT MANAGER: Dr. Grayson Walker,
 DSN 654-2594
 COMM 703/704-2594
 FAX: DSN 654-2467
 E-Mail: gwalker@nvl.army.mil



Desert

Woodland

**Winter
(Snow)**

ACQUISITION CATEGORY: N/A
ACQUISITION PHASE: 0

PE & LINE #: 62712/AH35

DESCRIPTION: The Advanced Signature Management and Deception program will demonstrate technologies that enable development of signature management and deception systems which deny acquisition of friendly force assets from threat sensors. Demonstrations will be supported by signature characterizations and modelling and simulation. These signature management and deception systems will provide mobile and semi-mobile assets with low cost, low operational burden survivability upgrades.

TRANSPORTATION CHARACTERISTICS / LIMITATIONS:

HISTORICAL BACKGROUND:

REQUIREMENTS DOCUMENT:

TYPE CLASSIFICATION:

<u>EVENT SCHEDULE</u>	FISCAL YEAR	97		98		99		00		01		02	
		QTR	1	2	3	4	1	2	3	4	1	2	3
Modelling and Simulation				1	-----	-----	-----	-----	-----	-----	4		
Develop IR coatings				1	-----	-----	4						
Feasibility study				1	-----	-----	4						
Develop hybrid system				1	-----	-----	-----	4					
Develop multi-spectral system								1	-----	-----	-----		

SYNOPSIS: DEVELOP SIGNATURE MANAGEMENT AND DECEPTION SYSTEM WHICH WILL DENY ACQUISITION OF FRIENDLY FORCE ASSETS FROM THREAT SENSORS.

NVESD

AERIAL SCOUT SENSORS INTEGRATION (ASSI)

PROJECT MANAGER: Mr. Jim Matheny,
 DSN 654-1256
 COMM 703/704-1256
 E-Mail: jmatheny@nvl.army.mil

ACQUISITION CATEGORY: N/A
ACQUISITION PHASE: MS 0 Concept Explor./Definition

PE & LINE: PE 63710 / DK86

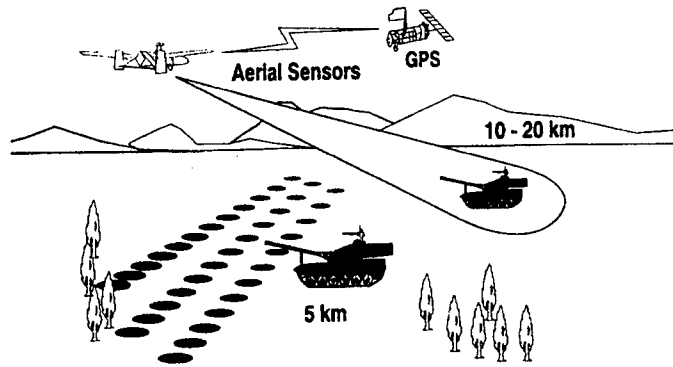

DESCRIPTION: ASSI will demonstrate utility of using airborne sensors to augment ground-based scouts by application of advanced over-the-hill battlefield reconnaissance, surveillance, targeting, and battle damage assessment techniques. Optimal data compression, automatic target detection/location procession, data link and work station interface techniques will be investigated.

TRANSPORTATION CHARACTERISTICS / LIMITATIONS: None.

HISTORICAL BACKGROUND: With the recent shift in US defense posture away from the threat of a once-dominant superpower entity toward multi-faceted threats scattered throughout the globe, the focus of future combat operation must change accordingly. The new emphasis on lighter, but more vulnerable, combat vehicles with greater tactical mobility has created the necessity of being able to engage the enemy's heavy armor before the opposition can engage our lighter forces.

REQUIREMENTS DOCUMENT: N/A

TYPE CLASSIFICATION: N/A

<u>EVENT SCHEDULE</u>	<u>FISCAL YEAR</u> QTR	97	98	99	00	01	02
		1 2 3 4	1 2 3 4	1 2 3 4	1 2 3 4	1 2 3 4	1 2 3 4
Image Collection		--1					
Sensor/Support Equip Acquisition		---2					
Equipment Integration		1-----	--1				
ASSI Demo			1--2				
RFPI ACTD			3--4				

SYNOPSIS: PROVIDES TOP-DOWN AND EXTENDED LONG-RANGE TARGET DETECTION, IDENTIFICATION, AND LOCATION.

NVESD

AIR/LAND ENHANCED RECONNAISSANCE AND TARGETING (ALERT) ATD

PROJECT MANAGER: Richard A. Wright,
E-Mail: wright@nvl.army.mil

ACQUISITION CATEGORY:
ACQUISITION PHASE: MS

PE & LINE #: 63710/DK86

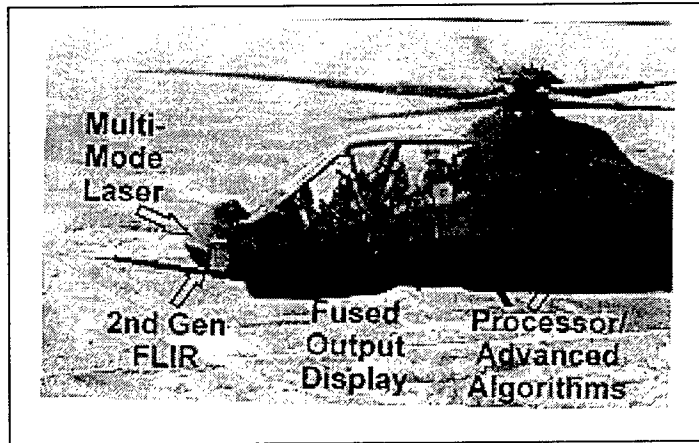

DESCRIPTION: The ALERT ATD will demonstrate on-the-move, automatic aided target acquisition and enhanced identification via the use of a second generation FLIR/Multi-function laser sensor suite for application to future aviation and, secondarily, ground assets, which do not have radar.

TRANSPORTATION CHARACTERISTICS / LIMITATIONS:

HISTORICAL BACKGROUND:

REQUIREMENTS DOCUMENT:

TYPE CLASSIFICATION:

<u>EVENT SCHEDULE</u>	<u>FISCAL YEAR</u>				<u>FISCAL YEAR</u>				<u>FISCAL YEAR</u>				<u>FISCAL YEAR</u>				<u>FISCAL YEAR</u>			
	<u>QTR</u>				<u>QTR</u>				<u>QTR</u>				<u>QTR</u>				<u>QTR</u>			
	1	2	3	4	1	2	3	4	1	2	3	4	1	2	3	4	1	2	3	4
Algorithm Database	1-----												-----3							
Algorithm Development					2-----								-----4							
Comanche Dual Mode Laser					4---				-----2											
Profile ID Laser					2-----								-----3							
UH-60 Integration					3---								-----3							
UH-60 Demonstrations					4				4				4							
Comanche MED Demo													1-----4							

SYNOPSIS: DEMONSTRATE ON-THE-MOVE, AIDED TARGET ACQUISITION AND IDENTIFICATION USING 2ND GENERATION FLIR AND MULTI-FUNCTION LASER.

NVESD

ARMY ATR EVALUATION

PROJECT MANAGER: Lynda Graceffo,
 DSN 654-1745
 COMM 703/704-1745
 FAX: DSN 654-1705
 E-Mail: graceffo@nvl.army.mil

ACQUISITION CATEGORY: N/A
 ACQUISITION PHASE: 0

PE & LINE #: 62709/DH95

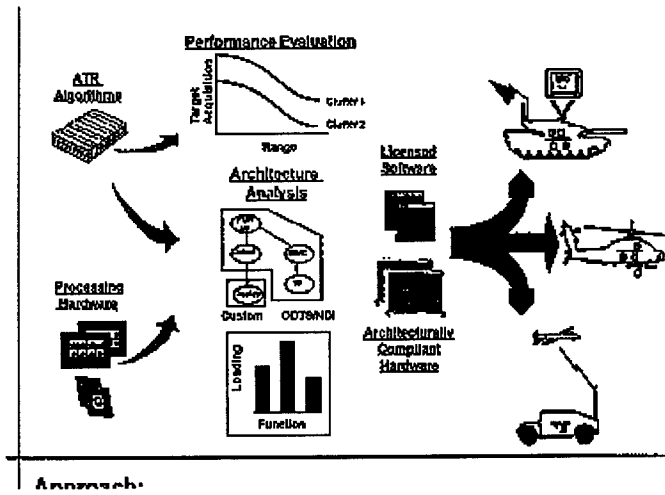

DESCRIPTION: This program provides the baseline evaluation of algorithms developed by industry/academia/government against established data sets to insure functional performance of ATRs.

TRANSPORTATION CHARACTERISTICS / LIMITATIONS:

HISTORICAL BACKGROUND:

REQUIREMENTS DOCUMENT:

TYPE CLASSIFICATION:

EVENT SCHEDULE	FISCAL YEAR		97		98		99		00		01		02	
	QTR		1	2	3	4	1	2	3	4	1	2	3	4
Open architecture concept and validation										4				
FLIR/Human ATR Performance				2										
SAR/ATR Performance										2				
Multi-sensor ATR performance				4						4				
Process Partitioning						2				4				

SYNOPSIS: PROVIDE BASELINE EVALUATIONS AND ANALYSES OF ALGORITHMS AND PROCESSING HARDWARE DEVELOPED BY INDUSTRY/ACADEMIA/GOVERNMENT.

NVESD

HUNTER SENSOR SUITE ATD

PROJECT MANAGER: Mr. Michael St. Peter,
 DSN 654-1231
 COMM 703/704-1231
 E-Mail: mstpeter@nvl.army.mil

ACQUISITION CATEGORY: N/A
ACQUISITION PHASE: MS 0 Concept Explor./Definition

PE & LINE: PE 63710 / DK70 / D440

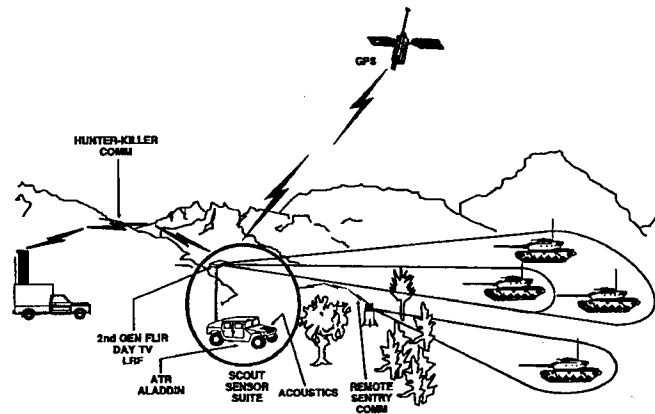

DESCRIPTION: Hunter Sensor Suite ATD will demonstrate a low observable advanced Long range Sensor Suite with ATR, image compression, and secure communications to provide multiple target acquisition and precision targeting hand-off integrated on stealthy hunter vehicles operating both stationary and on-the-move. This ATD will combine 2nd generation thermal imaging, day TV, eye safe laser rangefinder and embedded aided target recognition technology coupled with the capability of performing image compression/transfer operations.

TRANSPORTATION CHARACTERISTICS / LIMITATIONS: None.

REQUIREMENTS DOCUMENT: N/A

TYPE CLASSIFICATION: N/A

EVENT SCHEDULE	FISCAL YEAR	97		98		99		00		01		02	
		1	2	3	4	1	2	3	4	1	2	3	4
Modeling and Simulation	QTR	1	-----	2									
AWE's		2											
RFPI		2	-----	1									
User Training				2									
RFPI ACTD				4									

SYNOPSIS: PROVIDES LONG RANGE TARGET ACQUISITION AS WELL AS INCREASE SEE-FIRST/SHOOT-FIRST CAPABILITIES.

NVESD

INTEGRATED COUNTERMEASURES

PROJECT MANAGER: Ray Irwin,
 DSN 987-2493
 COMM 732/427-2493
 E-Mail: rirwin@nvl.army.mil

ACQUISITION CATEGORY: N/A
ACQUISITION PHASE:

PE & LINE #: 63270/DK16

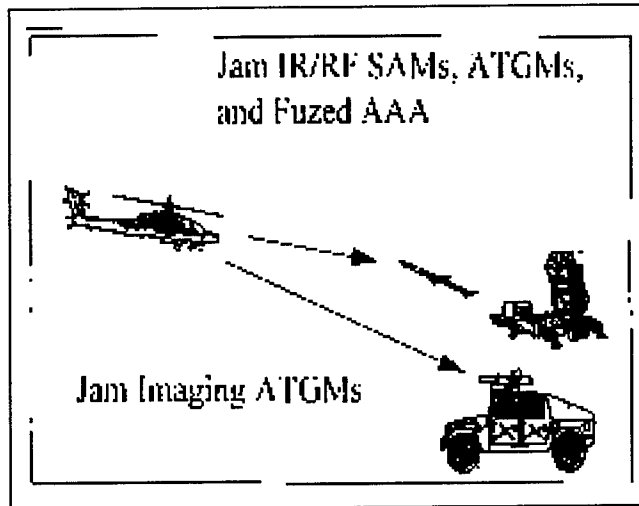

DESCRIPTION: Develop and demonstrate an integrated multi-spectral RF and IR countermeasures capability that will provide Army aviation full spectrum protection to counter air defense systems.

TRANSPORTATION CHARACTERISTICS / LIMITATIONS:

HISTORICAL BACKGROUND:

REQUIREMENTS DOCUMENT:

TYPE CLASSIFICATION:

<u>EVENT SCHEDULE</u>	<u>FISCAL YEAR</u>		97		98		99		00		01		02	
			1	2	3	4	1	2	3	4	1	2	3	4
Upgrade SIL Digital SAMS							1			3				
DIS testing with Battle Labs							2			4				
Integration of Countermeasures							2				2			
Develop and test SAM/AAA CM							3				2			
Field Test CM											2	3		
Transition to EMD											4			
Transition to CAGES Demo test											4		2	

SYNOPSIS: DEVELOP AND DEMONSTRATE AN INTEGRATED MULTI-SPECTRAL RF AND IR COUNTERMEASURES CAPABILITY FOR FULL SPECTRUM PROTECTION FOR ARMY AVIATION.

NVESD

INTEGRATED SENSOR MODELING AND SIMULATION

PROJECT MANAGER: Luanne Obert,
 DSN 654-1754
 COMM 703/704-1754
 FAX: DSN 654-1753
 E-Mail: lobert@nvl.army.mil

ACQUISITION CATEGORY: N/A
ACQUISITION PHASE: 0

PE & LINE #: 62709/DH95

- Sensor/ATR Evaluation
- Distributed Operational Simulations
- Assessment of New Weapon Concepts
- Virtual Prototyping



- High Resolution Synthetic Images
- Multispectral 3D Target Models and Backgrounds

Search and Target Acquisition Training

- Interactive 3-D Multimedia
- Schoolroom, Embedded Trainers and DIS
- Motivation Based On Learning Theory
- Interaction With All Users For Design

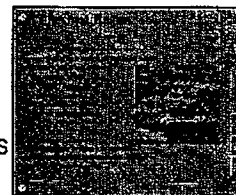

DESCRIPTION: This program will advance the state-of-the-art in synergistic modeling and prototyping capabilities to permit end to end predictive modeling and hardware tradeoffs for performance evaluation of new technologies in a virtual environment. Develop high resolution three dimensional target background and clutter databases which scale from infantry to airborne applications. Features will include realistic portrayal of advanced sensors such as 3rd generation FLIR, acoustics and radars, fused sensors, low observables and mine targets.

TRANSPORTATION CHARACTERISTICS / LIMITATIONS:

HISTORICAL BACKGROUND:

REQUIREMENTS DOCUMENT:

TYPE CLASSIFICATION:

<u>EVENT SCHEDULE</u>	<u>FISCAL YEAR</u> QTR	97				98				99				00				01				02			
		1	2	3	4	1	2	3	4	1	2	3	4	1	2	3	4	1	2	3	4				
Modeling and Analysis						1	-----	-----	-----	-----	-----	-----	-----	-----	-----	-----	-----	-----	-----	-----	-----	-----	-----	-----	-----
Multi Spectral Imagery						3	-----	-----	-----	-----	-----	-----	-----	-----	-----	-----	-----	-----	-----	-----	-----	-----	-----	-----	-----
MMW and SAR Simulation						3	-----	-----	-----	-----	-----	-----	-----	-----	-----	-----	-----	-----	-----	-----	-----	-----	-----	-----	-----
Simulation Enhancements														4	---	-----	-----	-----	-----	-----	-----	-----	-----	-----	-----

SYNOPSIS: DEVELOP STATE-OF-THE-ART SYNERGISTIC MODELING AND PROTOTYPING CAPABILITIES WHICH PERMIT END TO END PREDICTIVE MODELING AND HARDWARE TRADE OFFS FOR PERFORMANCE EVALUATION IN A VIRTUAL ENVIRONMENT.

NVESD

INTEGRATED SENSORS & TARGETING

PROJECT MANAGER: Steve Oshel,
 DSN 987-3225
 COMM 732/427-3225
 E-Mail: soshel@nvl.army.mil

ACQUISITION CATEGORY: N/A
ACQUISITION PHASE:

PE & LINE #: 63270/DK16

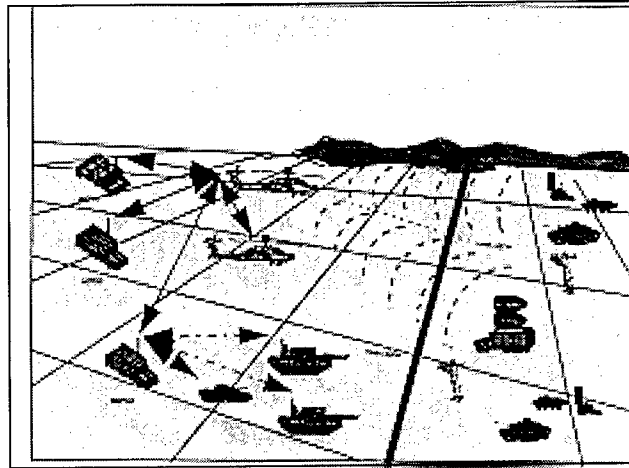

DESCRIPTION: Demonstrate HTI RF, missile and laser warning upgrades that provide precision hostile situation awareness, target acquisition and geolocation plus combat ID assist for active emitters.

TRANSPORTATION CHARACTERISTICS / LIMITATIONS:

HISTORICAL BACKGROUND:

REQUIREMENTS DOCUMENT:

TYPE CLASSIFICATION:

<u>EVENT SCHEDULE</u>	<u>FISCAL YEAR</u>												
	97		98		99		00		01		02		
	1	2	3	4	1	2	3	4	1	2	3	4	
<u>QTR</u>													
Upgrade SIL					1-----							4	
Determine Comm Link BW					2-----							3	
Develop & Integrate sensors					4-----							4	
Target Damage Assess. Alg.					1-----							-1	
Install on Aircraft and Ground Vehicles										4-----		2	
Field Test & Final Report												2-----	4
Transition to EMD													4

SYNOPSIS: DEMONSTRATE HTI RF, MISSILE AND LASER WARNING UPGRADES THAT PROVIDE HOSTILE SITUATION AWARENESS, TARGET ACQUISITION, GEOLOCATION AND COMBAT ID ASSIST.

NVESD

**LIGHTWEIGHT, AIRBORNE, MULTISPECTRAL,
COUNTERMINE DETECTION SYSTEM**

PROJECT MANAGER: Robert Barnard,
DSN 654-1066
COMM 703/704-1066
FAX: DSN 654-1040

ACQUISITION CATEGORY: N/A
ACQUISITION PHASE: 0

PE & LINE #: 62712/AH24 and 63606/D608

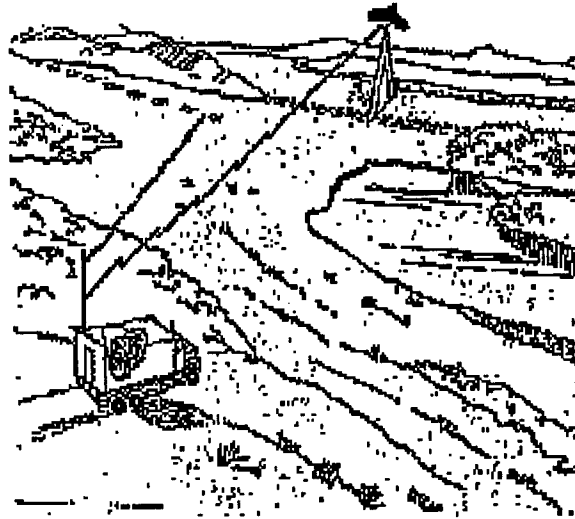

DESCRIPTION: This program will explore concepts and technologies to support a lightweight airborne mine detection capability for limited area, limited corridor route reconnaissance and detection of nuisance mines along roads. A variety of technologies will be investigated such as 3-5 micron FPAs (staring), multi-spectral/hyperspectral, passive polarization, active sources, and electronic stabilization for tactical UAVs.

TRANSPORTATION CHARACTERISTICS / LIMITATIONS:

HISTORICAL BACKGROUND:

REQUIREMENTS DOCUMENT:

TYPE CLASSIFICATION:

<u>EVENT SCHEDULE</u>	FISCAL YEAR QTR	97				98				99				00				01				02			
		1	2	3	4	1	2	3	4	1	2	3	4	1	2	3	4	1	2	3	4				
Modeling & Simulation						1	-----	-----	-----	-----	-----	-----	-----	-----	-----	-----	-----								
Component Development							4	-----	-----	-----	-----	-----	-----												
Mods to Detection Algorithms										1	-----	-----	-----												
Integration														1	-----	-----	-----	-----	-----	-----	-----				
Demonstration																				3	-----				

SYNOPSIS: DEVELOP A LIGHTWEIGHT AIRBORNE, STAND OFF MINE DETECTION CAPABILITY FOR LIMITED AREA, LIMITED CORRIDOR ROUTE RECONNAISSANCE, AND DETECTION OF NUISANCE ROAD MINES, DEPLOYED ON TACTICAL UAV.

NVESD

LOW COST EO/IR COUNTERMEASURES

PROJECT MANAGER: Dr. Joe O'Connell
DSN 992-5570
COMM 732/532-5570
E-Mail: joconnel@nvl.army.mil

ACQUISITION CATEGORY: N/A
ACQUISITION PHASE:

PE & LINE #: 62770/A442

DESCRIPTION: Development of active/passive devices to protect aircraft and ground vehicles with conventional and suppressed signatures from EO/IR guided threats.

TRANSPORTATION CHARACTERISTICS / LIMITATIONS:

HISTORICAL BACKGROUND:

Will build upon current STO, Advanced EO/IR Countermeasures.

REQUIREMENTS DOCUMENT:

TYPE CLASSIFICATION:

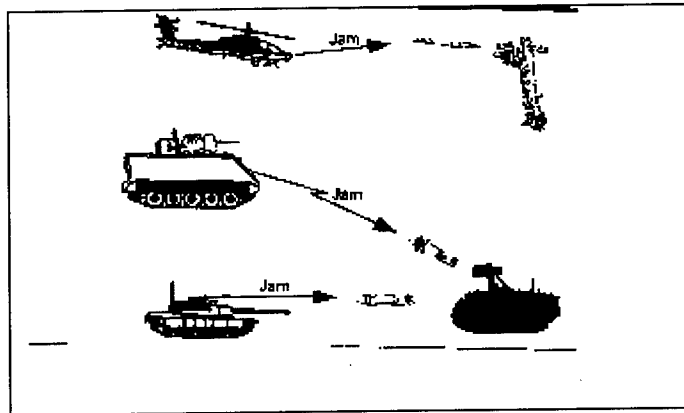

EVENT SCHEDULE	FISCAL YEAR											
	97		98		99		00		01		02	
	1	2	3	4	1	2	3	4	1	2	3	4
IRCM Jamming Effects, Test and Simulation					1							4
On/Off Board Jamming Techniques					1							4
Non Mechanical Laser Steering					1							1
Multi-band IR/UV CM Laser						4						4
Field Test & Transition												3-4

SYNOPSIS: DEVELOP ACTIVE/PASSIVE DEVICES TO PROTECT AIR AND GROUND VEHICLES WITH SUPPRESSED SIGNATURES FROM EO/IR GUIDED THREATS.

NVESD

**AN/PVS-6, MINI EYESAFE LASER INFRARED
OBSERVATION SET (MELIOS)**

PROJECT LEADER: Mr. Richard Renairi,
DSN 654-1204
COMM 703/704-1204
FAX: 703/704-3449
E-Mail: rrenairi@nvl.army.mil

ACQUISITION CATEGORY: III
ACQUISITION PHASE: MS III Production/Deployment

PE & LINE #: 644710.DL70 SSN: B53800
NSN: 5860-01-350-8551



DESCRIPTION: The MELIOS will provide the individual soldier with accurate range azimuth and vertical angle determination to provide target acquisition data for direct and indirect weapons systems in eyesafe mode. MELIOS will replace the AN/GVS-5 Laser Infrared Observation Set. AN/GVS-5 is not eyesafe. MELIOS is designed for ranges out to ten kilometers with plus or minus five meter accuracy. It operates in the eyesafe wavelength region allowing maximum use by units in training and tactical exercises. A compass/vertical angle measurement (C/VAM) capability has been added to MELIOS in addition to the range capability. MELIOS will increase first round hit probabilities during battlefield engagements, expedite target acquisition and provide accurate ranges for Ground-to-Air Defense. It will enhance the effective conduct of reconnaissance, surveillance and terrain navigation. It will be carried in a small, water resistant padded pouch that is attachable to the soldier's web gear. Fielding is one per infantry squad, other distribution to combat, SOF and combat support units to be determined.

TRANSPORTATION CHARACTERISTICS / LIMITATIONS: Carry Case: 6" x 12" x 14", 6 lbs. Shipping Case: 13 lbs.

HISTORICAL BACKGROUND:

- Sep 83 Two Cost Plus Fixed Fee contracts awarded.
- Sep 88 Development Production Prove-Out contract award.
- Jul 91 OT-II successfully completed; Efforts to insert compass/vertical angle measurement restarted.
- Dec 92 Milestone III approval.
- Apr 94 MELIOS FUE.
- Apr 95 C/VAM qualified.

REQUIREMENTS DOCUMENT: ROC, Feb 87.

TYPE CLASSIFICATION: Standard approved 4QFY94.

<u>EVENT SCHEDULE</u>	<u>FISCAL YEAR</u>						
	97	98	99	00	01	02	
	1 2 3 4	1 2 3 4	1 2 3 4	1 2 3 4	1 2 3 4	1 2 3 4	
Production/Deliveries		3					
Transition	4						

SYNOPSIS: MELIOS IS DESIGNED TO MEET ALL RANGING REQUIREMENTS OF THE INFANTRY AND SELECTED REQUIREMENTS OF OTHER BRANCHES AND SERVICES OUT TO RANGES OF 10KM WITH PLUS OR MINUS 5M ACCURACY.

NVESD

MICRO EYESAFE SOLID STATE LASER SOURCES

PROJECT MANAGER: Ward Trussell
DSN 654-1752
E-Mail: ctrussel@nvl.army.mil

ACQUISITION CATEGORY:
ACQUISITION PHASE:

PE & LINE #:

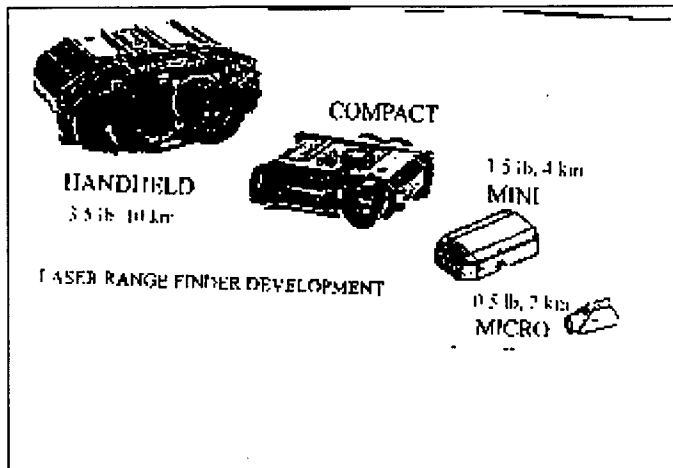

DESCRIPTION: Develop micro low cost laser devices that will complement larger multi-function lasers in the areas of weapons ranging, lightweight mid IR/FAR IR sources for IRCM and laser radar for munitions.

TRANSPORTATION CHARACTERISTICS / LIMITATIONS:

HISTORICAL BACKGROUND:

REQUIREMENTS DOCUMENT:

TYPE CLASSIFICATION:

<u>EVENT SCHEDULE</u>	<u>FISCAL YEAR</u>		97	98	99	00	01	02
	<u>QTR</u>		1 2 3 4	1 2 3 4	1 2 3 4	1 2 3 4	1 2 3 4	1 2 3 4
Develop compact DPSS laser					1-----	-----1		
High peak power laser diodes					3-----	-----3		
Build prototype systems						1-----	-----2	
Demo micro rangefinding systems								1-----4

SYNOPSIS: DEVELOP LOW COST MICRO LASER DEVICES/SOURCES FOR WEAPONS RANGING, LIGHTWEIGHT MID IR/FAR IR SOURCES FOR IRCM AND LASER RADAR FOR MUNITIONS.

NVESD

MINE HUNTER/KILLER

PROJECT MANAGER: Ricky Stanfield,
 DSN 654-2452
 COMM 703/704-2452
 FAX: DSN 654-2467
 E-Mail: stanfiel@nvl.army.mil

ACQUISITION CATEGORY: N/A
ACQUISITION PHASE: 0

PE & LINE #: 62786/AH20 Mil
 62712/AH24 and 63606/D608

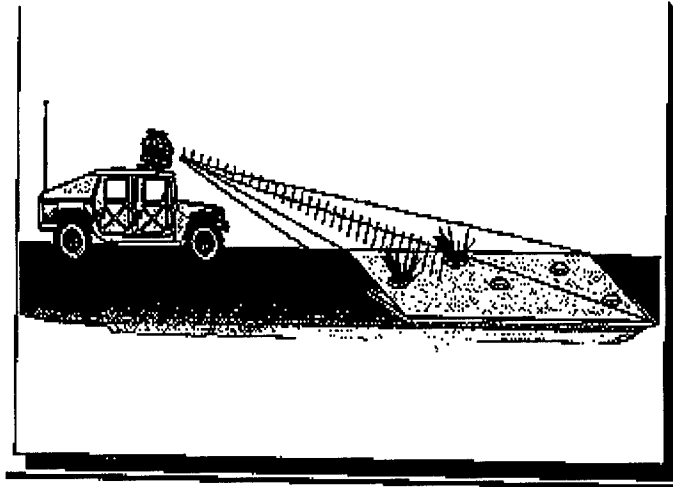

DESCRIPTION: The Mine Hunter/Killer program will demonstrate an infrared detection scheme on a combat vehicle. Explosive neutralization technologies will be tested and evaluated. Enhanced mine detection sensors will be integrated onto a surrogate platform and mine detection and neutralization will be demonstrated.

TRANSPORTATION CHARACTERISTICS / LIMITATIONS:

HISTORICAL BACKGROUND:

REQUIREMENTS DOCUMENT:

TYPE CLASSIFICATION:

<u>EVENT SCHEDULE</u>	<u>FISCAL YEAR</u>											
	97		98		99		00		01		02	
	1	2	3	4	1	2	3	4	1	2	3	4
Modeling and Analysis									1			
Detection Enhancements									2			
Neutralization Technologies									2			
System Integration					3					3		
Demonstration										3-4		

SYNOPSIS: DEVELOP AN INTEGRATED SYSTEM CONCEPT FOR AUTONOMOUS DETECTION AND DESTRUCTION OF MINES AT MANEUVER SPEEDS.

NVESD

MULTI-FUNCTION STARING SENSOR SUITE ATD

PROJECT MANAGER: Paul Laster,
DSN 654-3492
COMM 703/704-3492
FAX: DSN 654-1111
E-Mail: plaster@nvl.army.mil

ACQUISITION CATEGORY: N/A
ACQUISITION PHASE: 0

PE & LINE #: 63710/DK70

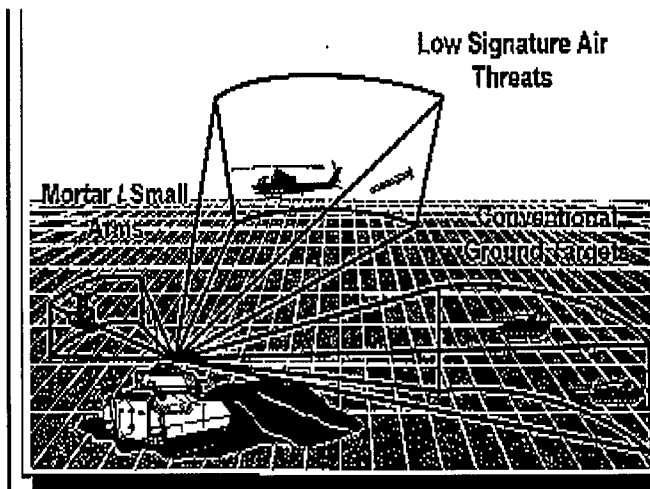

DESCRIPTION: This program will demonstrate a modular reconfigurable sensor suite that integrates staring infrared arrays, multi-function laser, and acoustic arrays. This sensor suite will provide ground vehicles and amphibious assault vehicles with a compact affordable sensor suite for long range target ID, monitor/sniper fire location, and air defense.

TRANSPORTATION CHARACTERISTICS / LIMITATIONS:

HISTORICAL BACKGROUND:

REQUIREMENTS DOCUMENT:

TYPE CLASSIFICATION:

<u>EVENT SCHEDULE</u>	<u>FISCAL YEAR</u>		97	98	99	00	01	02
	<u>QTR</u>		1 2 3 4	1 2 3 4	1 2 3 4	1 2 3 4	1 2 3 4	1 2 3 4
Modular Backplane				3-----4				
Staring FLIR				3-----		---2		
Laser/Acoustics					1-----	---2		
Sensor Integration						1-----	---2	
Demonstration							3--4	

SYNOPSIS: DEMONSTRATE A COMPACT AFFORDABLE, MULTI-FUNCTION MORTAR/SNIPER FIRE LOCATION, LOW OBSERVABLE DETECTION, NON-COOPERATIVE TARGET ID, AND AIR DEFENSE SENSOR SUITE.

NVESD

MULTI-MISSION/COMMON MODULAR UAV SENSORS

PROJECT MANAGER: John Cervini,
 DSN 987-4228
 COMM 732/427-4228
 FAX: DSN 987-3225
 E-Mail: jcervini@nvl.army.mil

ACQUISITION CATEGORY: N/A
ACQUISITION PHASE: 0

PE & LINE #: 63772/D243 & 63710/DK86

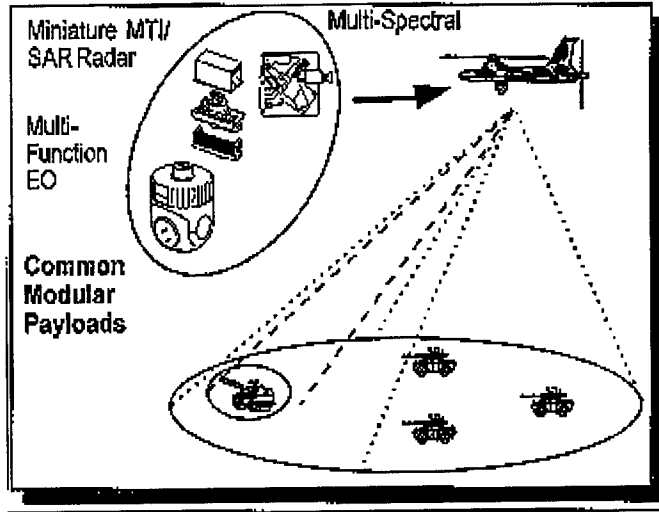

DESCRIPTION: This program will demonstrate low cost EO/IR-multi-spectral lightweight MTI Radar/SAR payloads for tactical UAVs. The EO payload will leverage high efficiency 3-5 micron staring arrays.

TRANSPORTATION CHARACTERISTICS / LIMITATIONS:

HISTORICAL BACKGROUND:

REQUIREMENTS DOCUMENT:

TYPE CLASSIFICATION:

EVENT SCHEDULE	FISCAL YEAR											
	97		98		99		00		01		02	
	1	2	3	4	1	2	3	4	1	2	3	4
	QTR											
Requirements Definition	1-----				--1							
Payload Design					1---3							
Fabrication					2-----		4					
Testing							4--		--1			
Integration							4--		-----		2	
Demonstrations									3-4			

SYNOPSIS: DEMONSTRATE LOW COST LIGHTWEIGHT COMMON MODULAR EO/IR MTI RADAR/SAR AND MULTI-SPECTRAL PAYLOADS FOR TACTICAL UAVs TO PROVIDE ENHANCED RECONNAISSANCE, SURVEILLANCE, BATTLE DAMAGE ASSESSMENT, AND TARGETING.

NVESD

MULTISPECTRAL COUNTERMEASURES ATD

PROJECT MANAGER: Mr. Bud Carbonaro,
 DSN 987-2676
 COMM 732/427-2676
 FAX: 732/532-5570
 E-Mail: acarbona@nvl.army.mil

ACQUISITION CATEGORY: N/A
ACQUISITION PHASE: MS I Demonstration & Validation

PE & LINE #: 63270/DK16

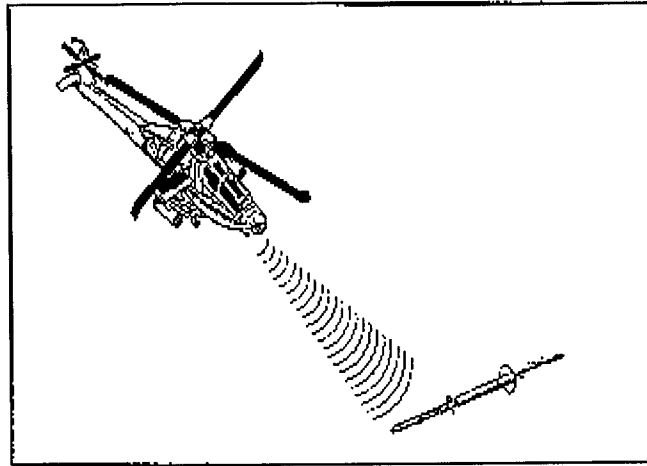

DESCRIPTION: This project will demonstrate advancements in laser technology, energy transmission, and jamming techniques for an all laser solution to IRCM and as a P3I to the Advanced Threat Countermeasures System (ATIRCM). These improvements will provide the capability to counter both present and future imaging focal plane array and non-imaging type missiles. A tuneable, multiline laser with a fiber optic transmission line, and advanced jamming algorithms will be live fire tested using the ATIRCM test bed.

TRANSPORTATION CHARACTERISTICS / LIMITATIONS: None.

HISTORICAL BACKGROUND: None.

REQUIREMENTS DOCUMENT: N/A

TYPE CLASSIFICATION: N/A

<u>EVENT SCHEDULE</u>	<u>FISCAL YEAR</u> QTR	97		98		99		00		01		02	
		1	2	3	4	1	2	3	4	1	2	3	4
Evaluate Fiber optic cable option					3								
Evaluate IRCM techniques with Laser						1							
Determine CM techniques vs Imaging missiles								2					
Integrate with ATIRCM			4					2					
Lab tests					3			2					
Live Fire Test								2					
Final Report								4					

SYNOPSIS: WILL DEMONSTRATE IMPROVEMENTS TO PRESENT IRCM SYSTEMS TO PROVIDE AN ALL LASER APPROACH AND DEMONSTRATE CM VS IMAGING TYPE SYSTEMS.

NVESD

MULTI WAVELENGTH MULTI FUNCTION LASER

PROJECT MANAGER: Ward Trussell,
 DSN 654-1355
 COMM 703/704-1355
 FAX: DSN 654-1752
 E-Mail: ctrussel@nvl.army.mil

ACQUISITION CATEGORY: N/A
ACQUISITION PHASE: 0

PE & LINE #: 62709/DH95

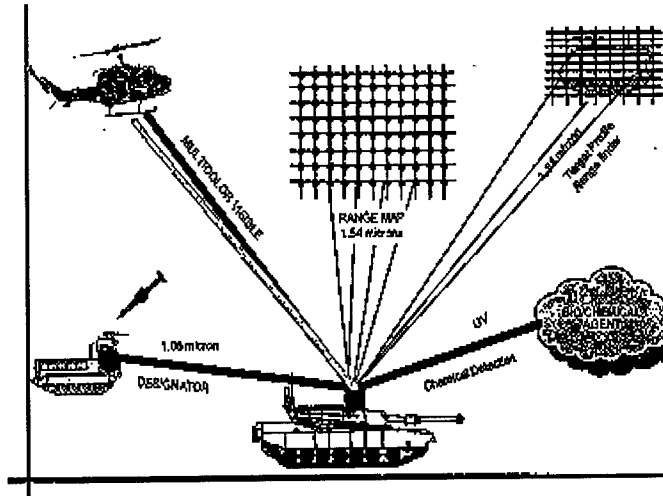

DESCRIPTION: Develop and demonstrate high efficiency compact laser diode pumped wavelength diverse laser source in the .26-5 micron region. Develop system controller software for multi-functional applications.

TRANSPORTATION CHARACTERISTICS / LIMITATIONS:

HISTORICAL BACKGROUND:

REQUIREMENTS DOCUMENT:

TYPE CLASSIFICATION:

<u>EVENT SCHEDULE</u>	<u>FISCAL YEAR</u>		97	98	99	00	01	02
	<u>QTR</u>		1 2 3 4	1 2 3 4	1 2 3 4	1 2 3 4	1 2 3 4	1 2 3 4
Diode Pumped Laser Module			---2					
MFMW Breadboard			1-----	--1				
MFMW Module				1-----	---2			
HTI Concept Demo					2---4			

SYNOPSIS: DEVELOP AND DEMONSTRATE HIGH EFFICIENCY COMPACT LASER DIODE PUMPED WAVELENGTH DIVERSE LASER SOURCE IN .26-5 MICRON REGION FOR VARIOUS APPLICATIONS.

NVESD

SOLID STATE NEAR IR SENSORS

PROJECT MANAGER: William Markey,
 DSN 654-1306
 COMM 703/704-1306
 FAX: DSN 654-1387
 E-Mail: wmarkey@nvl.army.mil

ACQUISITION CATEGORY: N/A
 ACQUISITION PHASE: 0

PE & LINE #: 62709/DH95

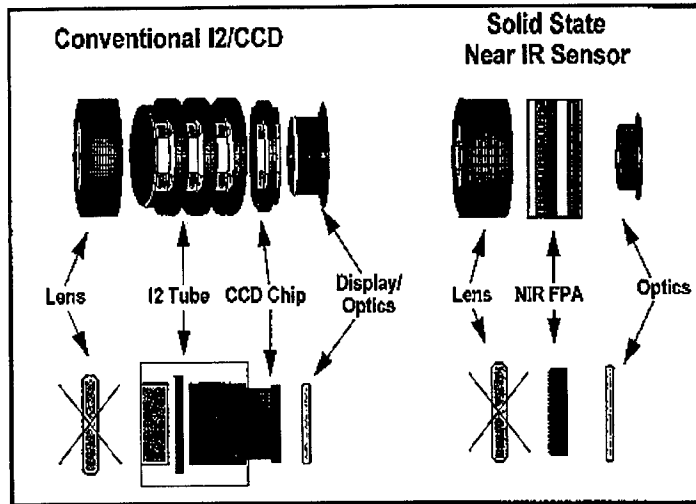

DESCRIPTION: This program will develop a low cost, lightweight, low light level, solid state sensor with smart readout chip. This technology will provide affordable high resolution for the 0.4-1.8 micron region. This system will be immune to bright light "flash outs" with no vacuum tube technology.

TRANSPORTATION CHARACTERISTICS / LIMITATIONS:

HISTORICAL BACKGROUND:

REQUIREMENTS DOCUMENT:

TYPE CLASSIFICATION:

EVENT SCHEDULE	FISCAL YEAR		97	98	99	00	01	02
	QTR		1 2 3 4	1 2 3 4	1 2 3 4	1 2 3 4	1 2 3 4	1 2 3 4
Data collection				1-----4				
Modeling				1-----	-----4			
IR camera development				1-----	-----4			
Large format IRFPA				1-----	-----4			
Demonstration/Integration							1-----4	

SYNOPSIS: DEVELOP LOW COST, LIGHT WEIGHT, LOW LIGHT LEVEL SENSOR THAT IS ALL SOLID STATE, IN THE 0.4-1.8 MICRON SPECTRAL REGION.

NVESD

TARGET ACQUISITION ATD

PROJECT OFFICER: Mr. Tim Watts,
 DSN 654-1356
 COMM 703/704-1356
 E-Mail: twatts@nvl.army.mil

ACQUISITION CATEGORY: N/A
ACQUISITION PHASE: MS 0 Concept Explor./Definition

PE & LINE: PE 63710 / DK87

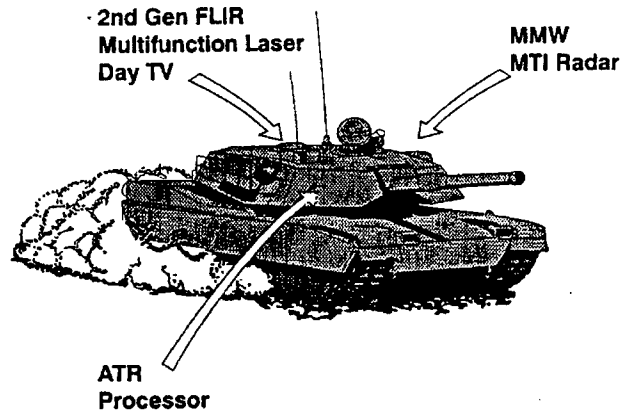

DESCRIPTION: Target Acquisition ATD will provide combat vehicles with improved long range target acquisition through the synergistic utilization of second generation FLIR, millimeter wave radar, and advanced aided target acquisition processing. These enhanced target acquisition capabilities will be coupled with combat identification technologies to significantly improve the Light Armored Combat vehicles lethality and survivability.

TRANSPORTATION CHARACTERISTICS / LIMITATIONS: None.

REQUIREMENTS DOCUMENT: N/A

TYPE CLASSIFICATION: N/A

<u>EVENT SCHEDULE</u>	<u>FISCAL YEAR</u>							
	97				98			
	1	2	3	4	1	2	3	4
	QTR				QTR			
Multifunction Laser MFLS cap	2							
ATD Hardware Evolution	1	-----	-----	4				
ATR Software Evolution	1	-----	---	2				
Abrams SEP Milestones	1	-----	-----	4				

SYNOPSIS: AN EXTENDED RANGE, MULTISENSOR TARGET ACQUISITION SUITE FOR FUTURE TANK, CAVALRY, AND SCOUT VEHICLES.

NVESD

**VEHICULAR MOUNTED MINE DETECTOR
ATD**

PROJECT MANAGER: Dr. Tom Broach,
DSN 654-1035
COMM 703/704-1035
E-Mail: tbroach@nvl.army.mil

ACQUISITION CATEGORY: N/A
ACQUISITION PHASE: MS 0 Concept
Explor./Definition

PE & LINE: PE 62786 / AH20 PE 63606 / D608

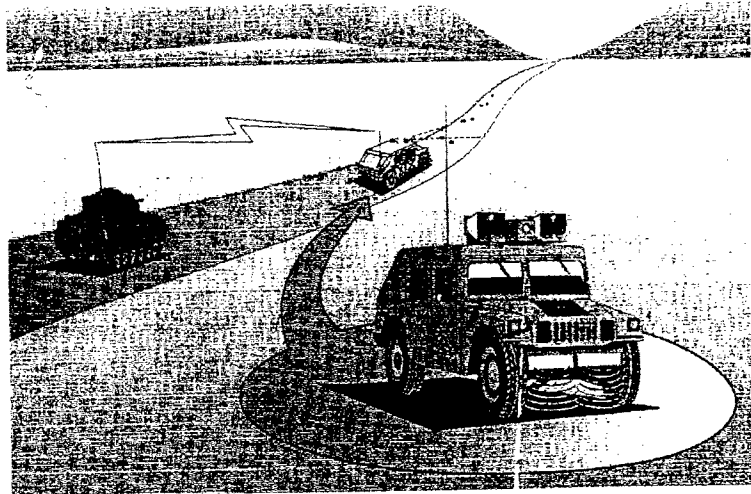

DESCRIPTION: The Vehicular Mounted Mine Detector ATD will develop mine detection technology to detect metallic and non-metallic mines both on and off roads at moderate speeds as well as enhance overall mobility and survivability for heavy and light forces. Detection performance improvement of 100 percent is expected when compared to the current metallic mine detector.

TRANSPORTATION CHARACTERISTICS / LIMITATIONS: None.

REQUIREMENTS DOCUMENT: N/A

TYPE CLASSIFICATION: N/A

<u>EVENT SCHEDULE</u>	<u>FISCAL YEAR</u>		97	98	99	00	01	02
	<u>QTR</u>		1 2 3 4	1 2 3 4	1 2 3 4	1 2 3 4	1 2 3 4	1 2 3 4
System Fabrication			1-----	----2				
Award ATD System Contract			1					
Demos			2					
Milestone I			4					

SYNOPSIS: VMMD WILL DETECT METALLIC AND NON-METALLIC MINES AT TACTICAL SPEEDS.

S&TCD

S&TCD

AIRBORNE RELAY

PROJECT MANAGER: Gerald T. Michael,
 DSN 987-2737
 COMM 732/427-2737
 E-Mail: michaelg@doim6.monmouth.army.mil

ACQUISITION CATEGORY:
ACQUISITION PHASE:

PE & LINE #:

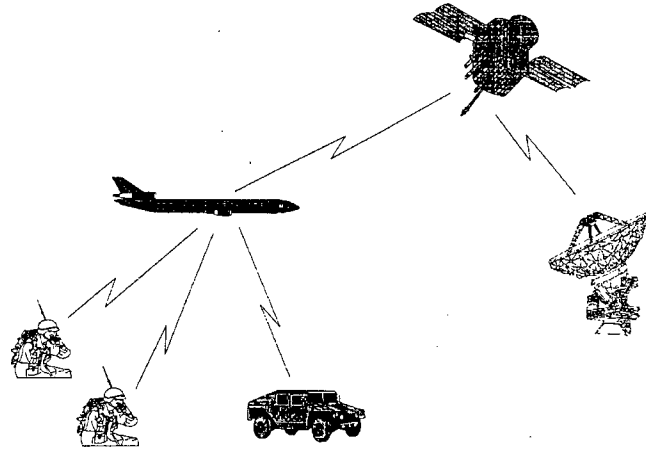

DESCRIPTION: The Airborne Relay project is developing a dual band relay consisting of a full duplex X-band capability supporting up to 45 Mbps and a simplex band broadcast at 1.5 Mbps. Additionally, Battlefield Broadcast receivers will be developed to support testing and demonstrations. The relay will be flown on a manned aircraft. The Airborne Relay program is a five year program, under the DBC ATD, which will culminate with JWID '99 demonstrations. This project has strong linkages to the Range Extension STO and DARPA's ACN ATD.

TRANSPORTATION CHARACTERISTICS / LIMITATIONS: Ground segment consists of RAPs and modified SATCOM Terminals. Objective broadcast terminal is the Handheld Multimedia terminal being developed under DARPA's Technology Reinvestment Program.

REQUIREMENTS DOCUMENT:

TYPE CLASSIFICATION:

RELEASEABLE TO SECURITY ASSISTANCE CUSTOMERS: Yes

<u>EVENT SCHEDULE</u>	<u>FISCAL YEAR</u>		97		98		99		00		01		02	
	QTR		1	2	3	4	1	2	3	4	1	2	3	4
First Payload			4											
Second Payload				2										
Test/Demo				2-3										
Broadcast Receiver Complete				2-3										
Demo on UAV				2										
Integrated RAP test					2-3									
JWID 99						4								

SYNOPSIS: DEVELOP HIGH CAPACITY AIRBORNE RELAY AND DEMONSTRATE THEIR UTILITY TO SUPPORT MOBILE TERRESTRIAL NETWORKS.

S&TCD

**AN/GSC-40, COMBINED GROUND COMMAND
POST TERMINAL**

PROJECT LEADER: Mr. Nathan Smith,
DSN 992-9210 x5633
COMM 732/532-9210 x5633

ACQUISITION CATEGORY:
ACQUISITION PHASE:

PE & LINE #: 738017Q2

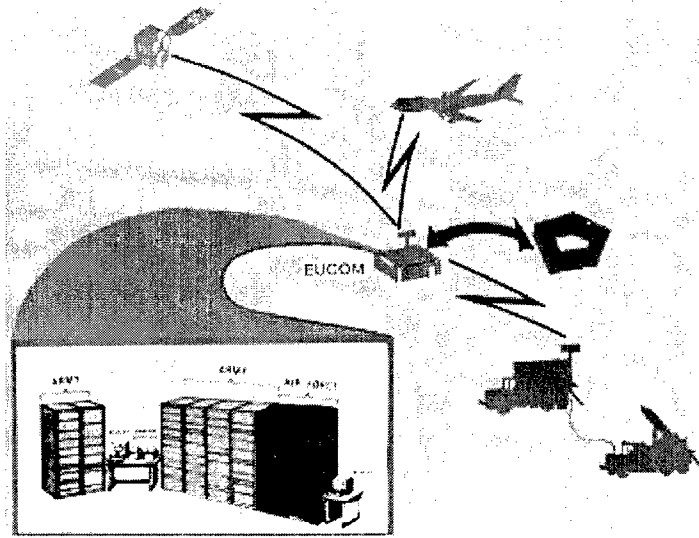

DESCRIPTION: The Ultra High Frequency (UHF) Special Communication System (SCS) ground segment consists of two satellite communications terminals: AN/GSC-40 Combined Ground Command Post Terminal; and AN/MSC-64 Force Terminal. AN/GSC-40 is a non-transportable rack configuration designed for installation into fixed command centers. It operates the SCS Force Terminal nets using from one to three AFSATCOM (5khz) channels depending on the number of AN/MSC-64s in the net. The system has limited antijam (AJ) capability and on-line encryption.

TRANSPORTATION CHARACTERISTICS / LIMITATIONS:

HISTORICAL BACKGROUND:

- Sep 80 Production MOU signed with Naval Ocean Systems Center (NOSC).
- Mar 81 Army directed to provide for two terminals to communicate simultaneously through two satellites (dual satellite access).
- Apr 81 First Article Test completed.
- Apr 83 First Unit Equipped (Europe).
- May 87 Initial Operational Capability (IOC) for first seven terminals.
- Sep 89 Firm requirements received to install SCTR in AN/GSC-40.
- 1Q94 USN, AN/GSC-40 taken out of operation. Location: London, England.
- 3Q94 U.S. Army, AN/GSC-40 taken out of operation. Location: Heidelberg, Germany.
 - o AN/GSC-40 terminals at these locations are no longer required.
- 1Q95 CINCPAC AN/GSC-40 taken out of operation. Location: Camp Smith, Hawaii.
- 2Q95 AF AN/GSC-40 taken out of operation. Location: Keesler AFB, Alabama.
 - o AN/GSC-40 terminals at these locations no longer required.

REQUIREMENTS DOCUMENT: ROC, Jan 77.

TYPE CLASSIFICATION: Standard approved May 83.

RELEASEABLE TO SECURITY ASSISTANCE CUSTOMERS: No

SYNOPSIS: AN/GSC-40 IS A SATELLITE COMMUNICATIONS CONTROL TERMINAL FOR THE UHF SPECIAL COMMUNICATION SYSTEM WHICH HAS LIMITED ANTI-JAM CAPABILITY AND ON-LINE ENCRYPTION. THE AN/GSC-40 IS THE COMMAND POST TERMINAL FOR NETWORKS MADE UP OF AN/MSC-64s AND AN/GSC-40s.

S&TCD

TSCTR - Components

AN/GSR-42, SINGLE CHANNEL
TRANSPONDER RECEIVING SET (SCTRS)

PROJECT LEADER: Mr. Nathan Smith,
DSN 992-9210 x5633
COMM 732/532-9210 x5633

ACQUISITION CATEGORY: IV
ACQUISITION PHASE:

PE & LINE #: MC



SHF Antenna
Subsystem

Demodulator and
Access Controller

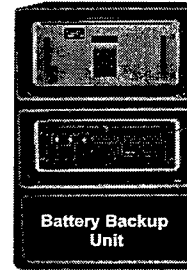

Printer

Power Control
Unit

KI-36

Battery Backup
Unit

DESCRIPTION: The SCTRS is a Product Improvement to the AN/MS-64 and AN/GSC-40 Ultra High Frequency (UHF) Satellite Communications Terminals that will permit reception of Emergency Action Messages (EAMs) in the Super High Frequency (SHF) Band. The SCTRS consists of a 3-foot parabolic antenna, demodulator and printer. It is a special purpose receiver. The SCTRS receives from the Single Channel Transponder on DSCS III Satellites. The SCTRS electronics shall be incorporated into transit cases for stand alone operation and mobility. This terminal is referred to as the Transportable Single Channel Transponder Receiver (TSCTR). The TSCTR will be used with a manpack UHF radio. 42 TSCTR terminals have been produced.

TRANSPORTATION CHARACTERISTICS / LIMITATIONS:

HISTORICAL BACKGROUND:

Feb 87	NDI contract award to MA/COM Government Systems, Incorporated.
Mar 89	Awarded printer Engineering Change Proposal.
Nov 90	Transitioned to Level II Management.
Sep 91	First Article Test complete.
Jul 92	Fielding commenced.
Jul 92-May 95	Fielded 27 SCTRS terminals to Europe and 2 terminals to Ft. Monmouth and 7 terminals to Ft. Gordon.
1Q94	Award ECP to modify SCTRS firmware to receiver Joint Staff formatted messages.
4Q94	Perform First Article Test on message format firmware modification.
3Q94	Joint Staff requests support from DA for TSCTR program.
4Q94	US Secretary of Defense offers TSCTR to NATO for rationalization.
1Q95	DA funds for TSCTR program.
3Q95	Award contract for transit cases and power supplies for TSCTR.
4Q95	Field new message format firmware.
4Q96	TSCTR passes EMP testing.

REQUIREMENTS DOCUMENT: ROC, Aug 74.

TYPE CLASSIFICATION: Standard approved Jun 77.

RELEASEABLE TO SECURITY ASSISTANCE CUSTOMERS: Yes

SYNOPSIS: SCTRS RECEIVE EAMs FROM THE SINGLE CHANNEL TRANSPONDER ON DSCS III SATELLITES.

S&TCD

**AN/MSC-64, SINGLE CHANNEL UHF SPECIAL
COMMUNICATIONS SYSTEM - FORCE
TERMINAL**

PROJECT LEADER: Mr. Nathan Smith,
DSN 992-9210 x5633
COMM 732/532-9210 x5633

ACQUISITION CATEGORY:
ACQUISITION PHASE:

PE & LINE #: 331.42 & E7090



DESCRIPTION: The AN/MSC-64 is an Ultra High Frequency (UHF) Satellite Communication System which receives Emergency Action Messages (EAMs) transmitted from the AN/GSC-40. There are three versions: AN/MSC-64(V)1 (Mobile Command Post); AN/MSC-64(V)2; and AN/MSC-64(V)3 (devanized). Secure record traffic communication is provided by all terminal types. The system makes use of satellites under AFSATCOM and Navy Fleet Satellite programs.

TRANSPORTATION CHARACTERISTICS / LIMITATIONS:

HISTORICAL BACKGROUND:

Jan 74 NDI decision.
Sep 78 Production contract awarded for AN/MSC-64 (all deliveries).
Feb 81 Initial Operational Capacity/First Unit Equipped (IOC/FUE).
Jan 86 Last operational terminals released to users.
Feb 87 Production contract for SCTR PIP was awarded to MA/COM Government Systems, Incorporated.
Sep 89 Firm requirement received to install SCTR in AN/MSC-64(V).
4Q94 Ft. Gordon discontinued training for AN/MSC-64(V).
4Q94 USAFE began training for AN/MSC-64(V).

REQUIREMENTS DOCUMENT: Original ROC 8-74.

TYPE CLASSIFICATION: Standard approved Jun 77.

RELEASEABLE TO SECURITY ASSISTANCE CUSTOMERS: No

SYNOPSIS: AN/MSC-64 IS A UHF SATELLITE COMMUNICATIONS SYSTEM WHICH RECEIVES EAMs TRANSMITTED FROM THE AN/GSC-40.

S&TCD

AN/USC-28(V), SATELLITE COMMUNICATIONS SET

PROJECT LEADER: Mr. Robert Yee,
 DSN 992-9783 x5437
 COMM 732/532-9783 x5437
 FAX: 732/542-4212
 E-Mail: yeer@doim6.monmouth.army.mil

ACQUISITION CATEGORY:
ACQUISITION PHASE:

PE & LINE #: BA8300

DESCRIPTION: The AN/USC-28(V) (Ground) is an advanced spread spectrum modulation system which operates with Defense Satellite Communications System (DSCS) satellite communications terminals to provide jamming resistant SATCOM network control and digital user communications. AN/USC-28(V) can be configured to accommodate up to 15 user data channels. The equipment interfaces with the Digital Communications Satellite Subsystem (DCSS) in fixed terminals and is also installed in the transportable AN/GSC-49(V) terminals. A special airborne version of the AN/USC-28(V) is installed in the Super High Frequency (SHF) terminal aboard the National Airborne Operations Center, the E-4B. The equipment interoperates with the Navy shipboard OM-55 Spread Spectrum equipment. The AN/USC-28(V), by virtue of the jamming protection it affords, insures the military utility of the DSCS. The AN/USC-28(V) modem was modified to mitigate the scintillation effects which would be caused by high altitude nuclear blast. The modification has backward capability so that the AN/USC-28(V) can operate in the normal mode or in the mitigated mode.

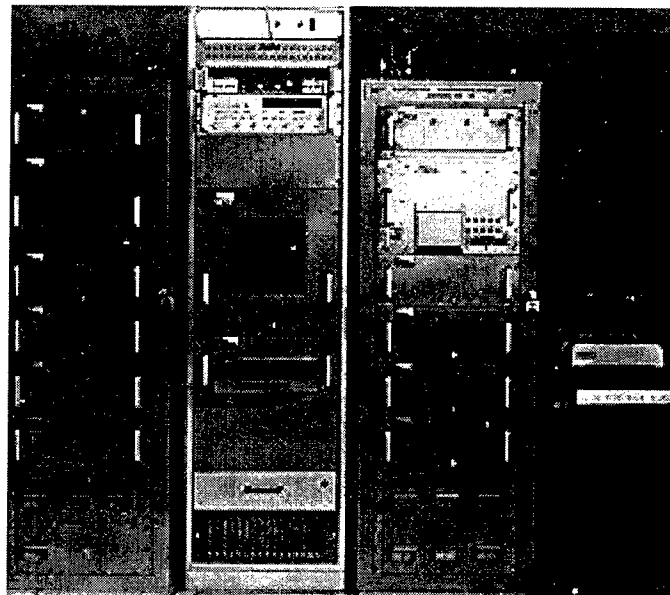

TRANSPORTATION CHARACTERISTICS / LIMITATIONS:

HISTORICAL BACKGROUND:

- Jun 78 IPR/Type Classification approval.
- Sep 78 First Production contract award.
- Nov 81 First Unit Equipped.
- Apr 82 Initial Operational Capability.
- Feb 87 Mitigation modification contract award.
- Nov 90 Transitioned to Level II Management.

REQUIREMENTS DOCUMENT: DSCS Program Plan as approved by Assistant Secretary of Defense.

TYPE CLASSIFICATION: Standard approved Jun 78.

RELEASEABLE TO SECURITY ASSISTANCE CUSTOMERS: Yes

<u>EVENT SCHEDULE</u>	FISCAL YEAR		97		98		99		00		01		02	
	QTR		1	2	3	4	1	2	3	4	1	2	3	4
Product Contract			-1											
Mitigation Conferencing Modification			-1											
Computer Modification									-1					

SYNOPSIS: AN/USC-28(V) PROVIDES AN ELECTRONIC COUNTER COUNTER MEASURE (ECCM) CAPABILITY FOR STRATEGIC SATCOM SYSTEMS.

S&TCD

**CX-13295/G, TACTICAL FIBER OPTIC CABLE
ASSEMBLY (TFOCA) and ANCILLARY ITEMS**

PROJECT OFFICER: Ms. Azza Meshal,
DSN 987-4034
COMM 732/427-4034
FAX: DSN 987-3267
COMM: 732/427-3267
E-Mail: meshal@doim6.monmouth.army.mil

ACQUISITION CATEGORY:
ACQUISITION PHASE:

PE & LINE #: CUSTOMER

DESCRIPTION: The TFOCA is used as a component of ground tactical fiber optic communications systems. These cable assemblies and ancillary items can be effectively utilized in deploying ground tactical field communications systems which are lightweight, small in size, and support dispersed operations due to extended non-repeatable transmission lengths. A completed cable assembly on a lightweight RC-453/G type reel consists of a specified length (up to 1 kilometer) of 6mm outer diameter cable containing two tightly-buffered, radiation hard, 50/125 micrometers multimode fibers terminated with duplex hermaphroditic biconic connectors. The connector is rugged, field installable, waterproof, and resistant to the stringent environment typical of tactical military applications. The cable assembly is rated and tested for operation at temperatures ranging from -55°C to +85°C. Cable assemblies are made in several lengths to meet various deployment configurations. They are easy to install, use no adhesives, and have excellent stability with temperature variations. The TFOCA has been designated as the Tactical Standard by the Joint Commanders Group for Communications-Electronics. Companion connector components were developed as part of the ancillary items. Cable assembly adaptors and repair kits are available as are cables and connectors for shelter modem installations.



TRANSPORTATION CHARACTERISTICS / LIMITATIONS:

HISTORICAL BACKGROUND:

Aug 84 TFOCA R&D contract awarded to AT&T.
Jan 86 TFOCA adopted by DOD as the standard for all ground tactical applications.
Mar 89 Production contract awarded to AT&T by PM, MSCS.
May 90 First Article Test successfully completed.
Oct 90 Proposal for requirements contract received.
Mar 92 TFOCA requirements contract award to AT&T Technologies.
Nov 95 TFOCA requirements contract extension award to AT&T Technologies.
Dec 97 Contract over.

REQUIREMENTS DOCUMENT: Not applicable as TFOCA is a component.

TYPE CLASSIFICATION: Standard approved 1989.

RELEASEABLE TO SECURITY ASSISTANCE CUSTOMERS: Yes

SYNOPSIS: TFOCA IS UTILIZED AS A COMPONENT OF GROUND TACTICAL FIBER OPTIC COMMUNICATIONS SYSTEMS.

S&TCD

**DIGITAL BATTLEFIELD COMMUNICATIONS
ATD**

PROJECT MANAGER: Mr. Gary Blohm,
DSN 987-4277
COMM 732/427-4277

Mr. T. Brutofsky,
DSN 987-2183
COMM 732/427-2183

ACQUISITION CATEGORY: RDT&E
ACQUISITION PHASE: 6.3

PE & LINE #: 63006 / D257
63006 / D247
62782 / AH92

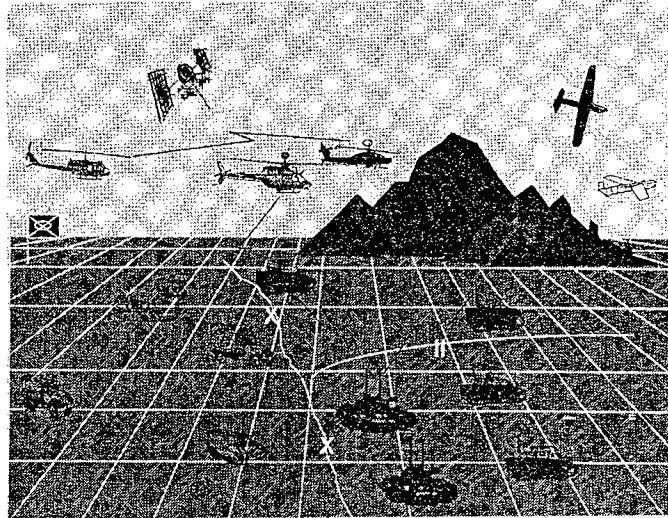

DESCRIPTION: This ATD will exploit emerging commercial communications technologies to support multimedia communications in a highly mobile dynamic battlefield environment. It will supplement and in some cases replace, "legacy" military communications systems which are unable to keep pace with the rapidly increasing demand for communications bandwidth and global coverage in support of Digitized Battlefield and split-based operations. It will evolve an integrated communications infrastructure which utilizes commercial protocols and standards to achieve global interoperability. Beginning in FY95 NDI wideband data radios will be evaluated and procured for testing in Task Force XXI. By FY96 commercial ATM technology will be integrated into actual tactical communications networks to provide "bandwidth on demand" to support multimedia information requirements. BCBL(G) will be supported in the DBC ATM experimentation through DS-3 connection to other service labs from FY96-99. In FY96 and 97 this program will demonstrate Direct Broadcast Satellite technology in support of JWID 96 and TF XXI AWE FY97. In FY97 Multi-Level Security requirements will be addressed by the insertion of TEED hardware into TF XXI. Wideband HF technology will be evaluated, tested in the CECOM DIL and inserted into the tactical internet. Leveraging from supporting 6.2 technology base programs, low profile SATCOM antenna technology products for both military (UHF, SHF) and commercial (C, Ku, X) SATCOM OTM from tactical vehicles, will be demonstrated in FY96 and 97. By FY99 an integrated phased array antenna will be demonstrated for the RAP. Work will continue on a full sized phased array antenna to address multibeam satellite and terrestrial high data rate communications on the move throughout FY99. Commercial terrestrial PCS will be demonstrated in FY97 and 98, respectively, to exploit commercial CDMA technology for WINPOC access. In order to extend ATM services to forward tactical units, a Radio Access Point (RAP) will be prototyped and tested in FY98. The RAP utilizes a high capacity on-the-move trunk radio to feed a variety of mobile subscriber services. By FY98, both manned and unmanned aerial platforms will be fitted with wideband relay packages to support OTM tactical operations, supporting bandwidths of up to 15 Mbps. This effort will be coordinated with, and executed in conjunction with DARO. Applicable products found to be acceptable through our commercial communications technology laboratory (C2TL) program, and evaluated jointly with TRADOC Battlelabs, will be inserted into the DBC program. This ATD will conclude in FY99 with the insertion of appropriate technology products in JWID 99 in support of high capacity digitized communications and split-based operations.

TRANSPORTATION CHARACTERISTICS / LIMITATIONS:

HISTORICAL BACKGROUND:

Apr 94 ATD Briefed to ASTWG.
Sep 94 ATD TDP issued.
Sep 95 ATD TDP Approved.

REQUIREMENTS DOCUMENT: N/A

TYPE CLASSIFICATION: N/A

RELEASEABLE TO SECURITY ASSISTANCE CUSTOMERS: Yes

<u>EVENT SCHEDULE</u>	<u>FISCAL YEAR</u>		97	98	99	00	01	02
	<u>QTR</u>		1 2 3 4	1 2 3 4	1 2 3 4	1 2 3 4	1 2 3 4	1 2 3 4
Phase I			-----4					
Phase II			4-----		-----4			
Phase III					4-----		-----4	

SYNOPSIS: ATD TO DEMONSTRATE CAPABILITY FOR SECURE, ROBUST, SEAMLESS, DIGITAL, MULTIMEDIA, INFORMATION TRANSPORT CAPABILITY FOR ARMY TACTICAL USER.

S&TCD

**DIGITAL COMMUNICATIONS SATELLITE
SUBSYSTEM (DCSS)**

PROJECT LEADER: Ms. Cathy Young,
DSN 992-9783
COMM 732/532-9783
FAX: 732/532-0852
E-Mail: dcss@cecom3.monmouth.army.mil

ACQUISITION CATEGORY: IV
ACQUISITION PHASE: MS III Production/Deployment

PE & LINE #: BB8501



DESCRIPTION: The DCSS encompasses the modulation, multiplex, coding and processing equipment necessary to assemble various types of user data into a digital form suitable for transmission over a Satellite Link, in both the protected and unprotected modes. The protected mode employs spread spectrum multiple access techniques utilizing the AN/USC-28 Modem. The unprotected mode employs frequency division multiple access techniques utilizing the OM-73 Modem. In the unprotected mode, the DCSS can feed the AN/FSC-78, AN/GSC-52, or AN/GSC-39 Terminal with up to 90 megabits of user data. DCSS is deployed as part of the Defense Satellite Communications System (DSCS) and essentially provides a unique wide band digital transmission capability. DCSS is required at each Earth Terminal Complex with the DSCS Network in either a building or a van configuration, and its modular design permits unique configurations to meet each DSCS site's specific communication requirement. The DCSS also provides the primary means of interoperable communications providing Tactical Field Commanders global connectivity with each other and with strategic commanders, CINC's and the Pentagon via the Standardized Tactical Entry Point (STEP) and the Multiplexer Integration and DCSS Automation System (MIDAS) Programs.

TRANSPORTATION CHARACTERISTICS / LIMITATIONS: Variable.

HISTORICAL BACKGROUND:

- 1977 U.S. Army Satellite Communication agency (USASATCOMA), as the Executive Agent for the Defense Communication Agency, ships the first DCSS consisting of 15 unique racks and equipment to Sunnyvale (Onizuka), CA.
- 1985 DCSS becomes all digital.
- 1989 USASATCOMA reorganized into PM SATCOM and Space Systems Directorate (SSD).
- 1989 DCSS Program Management transitions to Space Systems Directorate.
- 1993 SSD joins with C3 Systems Directorate to form Space & Terrestrial Communications Directorate.
- 1997 Total investment to date: \$387M.

REQUIREMENTS DOCUMENT: DISA DSCS FY98-03 Program Plan.

TYPE CLASSIFICATION: N/A

RELEASEABLE TO SECURITY ASSISTANCE CUSTOMERS: Yes

SYNOPSIS: DCSS PROVIDES DIGITAL EQUIPMENT CAPABILITIES FOR DSCS TERMINAL SITES.

S&TCD

DIRECT BROADCAST SATELLITE (DBS)

PROJECT MANAGER: Ivan Velinov,
DSN 987-2738
COMM 732/427-2738

ACQUISITION CATEGORY: II
ACQUISITION PHASE: MS II Demo/Validation

PE & LINE: D247 Development
D257

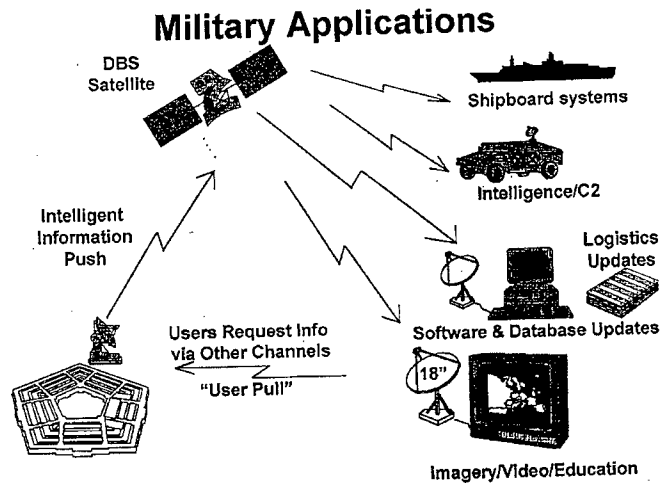

DESCRIPTION: Develop and demonstrate military applications of commercially available technology in the broadcasting of imagery, data, and other information via Direct Broadcast Satellite (DBS) system. DBS is a new commercial technology utilizing high power satellites to transmit digital signals to small (18 inch), inexpensive receivers. Compression techniques enable data rates sufficient to transmit motion video, databases, and other digital information. Program evolves to provide an in-theater capability using airborne relays to reduce dependence on commercial satellites, as well as development of a mobile uplink system.

TRANSPORTATION CHARACTERISTICS / LIMITATIONS: Uplink is a fixed-site on trailer-transportable earth station. Downlink is shipped disassembled, in two-transit cases approximately 26x55x11 inches and 80 pounds each.

REQUIREMENTS DOCUMENT: CONOPS, JORD.

TYPE CLASSIFICATION:

RELEASEABLE TO SECURITY ASSISTANCE CUSTOMERS: Yes

EVENT SCHEDULE	FISCAL YEAR				FISCAL YEAR				FISCAL YEAR				FISCAL YEAR				FISCAL YEAR			
	QTR				QTR				QTR				QTR				QTR			
TF XXI preparation	-1																			
TF XXI	2																			
GBS receive capability Demo on a mobile ground platform					2															

SYNOPSIS: DBS IS A NEW COMMERCIAL TECHNOLOGY UTILIZING HIGH POWER SATELLITES TO TRANSMIT DIGITAL SIGNALS TO SMALL (18 INCH), INEXPENSIVE RECEIVERS.

S&TCD

INTEGRATED PHOTONIC SUBSYSTEMS (IPS)



Integrated Photonic Subsystems

PROJECT MANAGER: Mr. Louis Coryell,
 DSN 987-3640
 COMM 732/427-3640
 FAX 732/427-3267
 E-Mail coryell@doim6.monmouth.army.mil

PROJECT ENGINEER: Mr. James Wright,
 DSN 987-2819
 COMM 732/427-2819
 FAX: 732/427-3267
 E-Mail: wright@doim6.monmouth.army.mil

ACQUISITION CATEGORY: N/A
ACQUISITION PHASE: MS 0 Concept Explor/Definition

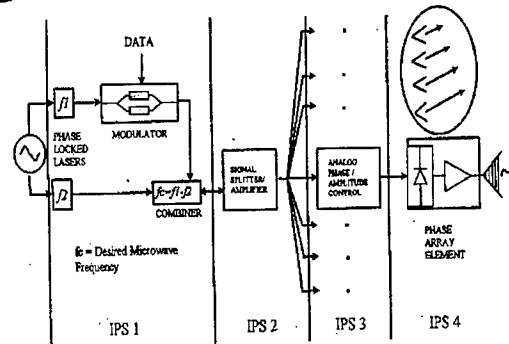

PE & LINE #: 62782.AH92
 63306.D247

DESCRIPTION: This effort will develop Integrated Photonic Subsystems (IPS) for the carrier generation, modulation, signal distribution and beamforming for control of phased array antennas which will be a required part of future tactical on-the-move communication and radar systems. A frequency independent approach is being followed. This will allow IPS use in a number of on-the-move applications both SATCOM and terrestrial communications (6-58 Ghz). Multiple beams and adaptive arrays will be supported. IPS development will lead to an Optically Controlled Phased Array Antenna installed in the Radio Access point CS-250 shelter or Standard Integrated Command Post and used for transmission through one or two airborne relays.

TRANSPORTATION CHARACTERISTICS / LIMITATIONS: IPS will be installed in standard shelter.

HISTORICAL BACKGROUND:

- Jun 93 Revised STO briefed to Battle Lab representatives.
- Mar 94 Contract awarded to GEC-Marconi Materials Corporation.
- Sep 94 Contract awarded to Boeing Defense & Space Group.
- Aug 95 Contract awarded to GEC-Marconi Materials Corporation.
- Jan 96 ILIR work on photonic T/R Module initiated.
- Mar 97 IPS proposed as Dual Use Application Program (DUAP).

REQUIREMENTS DOCUMENT: Science and Technology Objective (STO) IV.G.01; Integrated Photonic Subsystems.

TYPE CLASSIFICATION: N/A; Effort will result in subsystem which will be incorporated into a number of systems.

RELEASEABLE TO SECURITY ASSISTANCE CUSTOMERS: No

EVENT SCHEDULE	FISCAL YEAR											
	97		98		99		00		01		02	
	QTR		QTR		QTR		QTR		QTR		QTR	
	1	2	3	4	1	2	3	4	1	2	3	4
Transition to System Prototypes				4								
Optical Phased Locked Loop Development							4					
256 element single panel development					1							2
DUAP Program					1							1
Field DEMO JWID 00												3-4

SYNOPSIS: INTEGRATED PHOTONIC SUBSYSTEMS WILL CONTROL THE BEAMFORMING / SHAPING NETWORKS FOR FUTURE TACTICAL COMM-ON-THE-MOVE SYSTEMS.

S&TCD

PCS FOR THE SOLDIER

PROJECT MANAGER: Perry Hugo,
 DSN 987-2295
 COMM 732/427-2295
 FAX: 732/427-2150
 E-Mail: hugo@doim6.monmouth.army.mil

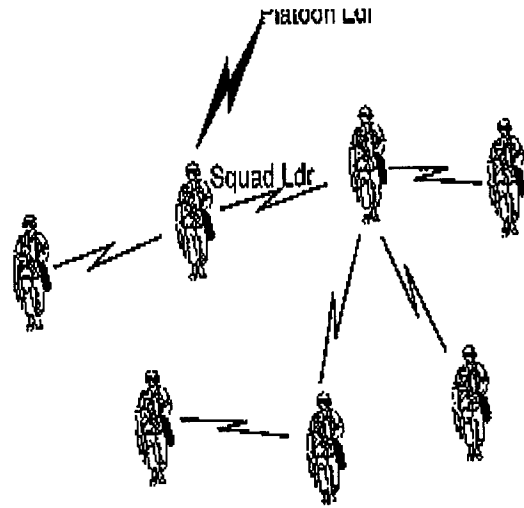

ACQUISITION CATEGORY: NA
ACQUISITION PHASE: 0

PE & LINE #: 0602782, Project: AH92, Task AH9205,
 Work Package H920003

DESCRIPTION: Adaptation and exploration of applying emerging commercial PCS products to provide communications for the dismounted infantry. This program also includes exploration of technologies developed by DARPA under the GloMo and Small Unit Operations (SUO) programs and the application of these technologies to dismounted infantry communications. The overall objective of this program is to develop the next generation soldier radio and transition technology to the Land Warrior acquisition program.

TRANSPORTATION CHARACTERISTICS / LIMITATIONS: Form and fit of current land warrior soldier radio.

HISTORICAL BACKGROUND:

- 1Q97 Project initiated and programmatically restructured to leverage DARPA SUO Program.
- 1Q97 Coordination with US Army TRADOC DBBL and Land Warrior acquisition program.
- 3Q97 Eight (8) DARPA SUO communications enabling technology development contracts awarded.
- 4Q97 Established laboratory testbed environment and initiated DARPA GloMo Program technology test and evaluation.

REQUIREMENTS DOCUMENT: Land Warrior System Specification, A3246133 (baseline).

TYPE CLASSIFICATION: N/A

RELEASEABLE TO SECURITY ASSISTANCE CUSTOMERS: Yes

EVENT SCHEDULE	FISCAL YEAR QTR	97				98				99				00				01				02			
		1	2	3	4	1	2	3	4	1	2	3	4	1	2	3	4	1	2	3	4				
DARPA SUO SAS Source Selection		2-3																							
Contract Award (study phase)						1																			
DARPA SUO SAS Communications enabling tech dev		3				3				3															
DARPA GloMo technology development		3				3				3				3											
Commercial Technology Assessment						2-4																			
Peer to Peer demo						4				-1															
Protocol Development						4				-4															
Integrated Testing														2-4											
Land Warrior Insertion														3-4											

S&TCD

TRI-BAND SATCOM SUBSYSTEM (TSS)

PROJECT MANAGER: Mr. John Deewall,
 DSN 992-9783 x5468
 COMM 732/532-9783 x5468

ACQUISITION CATEGORY: N/A
ACQUISITION PHASE: N/A

PE & LINE #:

DESCRIPTION: The TSS (System 1) is a tri-band SATCOM subsystem designed for use with the Army TENCAP MIES System. This terminal permits operation on military or commercial satellites in the C, X and Ku bands utilizing a single tri-band feed. The terminal consists of a 20 foot ISO shelter and a trailer mounted 20 foot diameter antenna subsystem which are transportable by C-130, C-141, or C-5 aircraft. The TSS provides a full duplex circuit capable of operating up to 256 KBPS and a receive-only circuit up to 6.2 Mbps. System 2 is comprised of a Tactical Mission Vehicle and AEG. Part of the TMW houses the System 1 OEG equipment that has been reracked/restacked to fit into a smaller area. The AEG for Systems 1 and 2 will be identical.



TSS Shelter and Antenna

TRANSPORTATION CHARACTERISTICS / LIMITATIONS: C-130, C-141 or C-5.

HISTORICAL BACKGROUND:

- May 91 MOA between CECOM S&TCD and customer.
- May 92 SPEC and SOW developed.
- Aug 93 RFP released.
- 3QFY94 Contract award.
- 4Q94 PDR First System.
- 1Q95 CDR.
- 4Q95 Original spec and SOW revised for System 2.
- 4Q95 Option for System 2 exercised.
- 1Q96 System Deployed.
- Certification Testing First System.
- 1Q96 Delivery/Acceptance First System.
- 2Q96 Delta PDR - System 2.
- 3Q96 Delta CDR - System 2.
- 4Q97 Acceptance testing System 2.
- 4Q97 Certification testing System 2.

REQUIREMENTS DOCUMENT: N/A

TYPE CLASSIFICATION: N/A

RELEASEABLE TO SECURITY ASSISTANCE CUSTOMERS: No

EVENT SCHEDULE - System #2	FISCAL YEAR QTR	97	98	99	00	01	02
		1 2 3 4	1 2 3 4	1 2 3 4	1 2 3 4	1 2 3 4	1 2 3 4
Certification		4					
Delivery		4					

SYNOPSIS: TSS IS A MULTI-BAND SATCOM TERMINAL BUILT TO PROVIDE ASSURED ACCESS TO SUPPORT INTEL DISSEMINATION.

S&TCD

UHF SATCOM-ON-THE-MOVE

UHF SATCOM-ON-THE-MOVE ANTENNA

PROJECT MANAGER: Mr. Bill Wong,
 DSN 992-9210 x5609
 COMM 732/532-9210 x5609

ACQUISITION CATEGORY:
ACQUISITION PHASE:

PE & LINE:

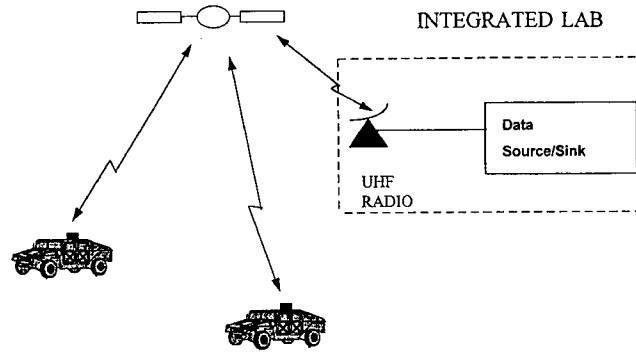

DESCRIPTION: This program will evaluate commercial-off-the-shelf UHF antennas to support SATCOM-On-The-Move (SOTM). The antenna will be robust and low profile in order to survive the operational scenario encountered by military vehicles while on-the-move and to minimize target identification by the enemy. Antenna gain will be chosen to optimally trade-off user communications capabilities and the antenna size. The antenna will support satellite tracking while mounted on a moving vehicle.

TRANSPORTATION CHARACTERISTICS / LIMITATIONS: Vehicle mounted (e.g. HMMWV).

HISTORICAL BACKGROUND:

FY93 Mechanically steered yagi antenna (3' profile) used to demonstrate UHF SOTM capability. Although this antenna was fielded in small quantities, its high profile is not well suited for typical operational environments.

REQUIREMENTS DOCUMENT: N/A

TYPE CLASSIFICATION:

RELEASEABLE TO SECURITY ASSISTANCE CUSTOMERS: Yes

EVENT SCHEDULE	FISCAL YEAR QTR	97	98	99	00	01	02
		1 2 3 4	1 2 3 4	1 2 3 4	1 2 3 4	1 2 3 4	1 2 3 4
Procurement of Antennas		-----3					
Test Evaluation		3--4					
Develop functional specification		4--	--1				
Prepare Acquisition Requirements Package			1--2				

SYNOPSIS: THIS PROGRAM WILL DEVELOP PROTOTYPE, LOW PROFILE, HIGH GAIN UHF ANTENNAS TO SUPPORT SATCOM-ON-THE-MOVE.

SEC

SEC

ARMY INTEROPERABILITY NETWORK (AIN)

PROJECT OFFICER: Mr. Ted Dzik,
DSN 992-1780
COMM 732/532-1780

ACQUISITION CATEGORY: IV
ACQUISITION PHASE: MS III Production/Deployment
PE & LINE #: 64805 097



DESCRIPTION: Develop, operate and apply the AIN, a unique nationwide distributed networked communications capability to meet life-cycle (technology/experimentation, development, AWEs/ACTDs, PPSS and joint certification) test support requirements for integration and interoperability of Army systems/software through distributed remote connection ("virtual relocation") of actual C4IEWs systems, labs/testbeds, field/test sites, developers facilities and Battle Labs. The AIN provides the broad support to affordable continuous sustainment and modernization of our equipment/systems. AIN's ability to rapidly engineer support solutions that replicate battlefield configurations by interconnecting actual fielded systems is instrumental in creating the environments needed to identify, recreate and resolve interoperability problems. The AIN is operational and successfully serving a growing customer base.

TRANSPORTATION CHARACTERISTICS / LIMITATIONS: A rapid deployment capability, in the form of Transportable Remote Site System and LOS Link, exists for short-term urgent requirements.

HISTORICAL BACKGROUND:

Apr 91	AIN Central Control operations began. First customer Test support using T1 (1.544Mbps) communications.	FY93	Supported 400 test-days, 17 sites, and established remote LAN, remote MSRT and dial-in capabilities.
Jul 91	MSE X.25 Protocol testing capability established.	FY94	Supported 1000 test-days, 23 sites, and established VC capability.
Sep 91	Transportable Remote Site System developed.	FY95	Supported 2500 test-days, 36 sites, and established ATM capability.
Nov 91	Block 0 Remote Sites (7) installed. TACSAT interface established.	FY96	Supported 5700 test-days, 40 sites, and established remote SINGARS interface and ISDN capabilities.
FY92	Supported 150 test days, 14 sites, and MSE interface Capability.	FY97	Supported 8800 test-days, 46 sites, and established 188-220/VMF test, KIV7 and GPS capabilities.

REQUIREMENTS DOCUMENT: HQ AMC approved ACCS CMIT Plan, Jun 86. System Engineering Implementation Plan, Feb 84. JINTACCS Management Plan, Mar 86. ATCCS TEMP (Revision 1), Jan 88. AIN O&O Plan, Apr 90. AIN SOR, Dec 90.

TYPE CLASSIFICATION:

RELEASEABLE TO SECURITY ASSISTANCE CUSTOMERS: No

<u>EVENT SCHEDULE</u>	<u>FISCAL YEAR</u> QTR	97	98	99	00	01	02
		1 2 3	1 2 3	1 2 3	1 2 3	1 2 3	1 2 3
Demonstrated wireless quick reaction link		1					
Established Pentagon Simulation Center site		1					
Established CTSF, Ft Hood site		1					
Task Force XXI AWE support		1 2					
Force XXI DAWE AWE support		2 3 4	1				
Support ULCHI FOCUS LENS Exercise		3					
Support Joint Certification Tests		1-----	-----	-----	-----	-----	-----4
Support VMF/188-220 protocol testing		1-----	-----	-----	-----	-----	-----4
Support approx 10,000 test-days/year (Force XXI)		1-----	-----	-----	-----	-----	-----4
Install new network sites IAW customer requirements		1-----	-----	-----	-----	-----	-----4

SYNOPSIS: AIN PROVIDES THE TOOLS TO EFFECTIVELY CLOSE THE GAP BETWEEN THE DEVELOPER, TESTER, TRAINER, AND IMPLEMENTOR OF ARMY C4IEWs SYSTEMS AND THE METHODOLOGY FOR CREATING AND MAINTAINING INTEROPERABILITY AMONG THEM.

SEC

VARIABLE MESSAGE FORMAT (VMF) TEST TOOL (VTT) & MIL-STD-188-220 PROTOCOL TEST TOOL (PTT)

PROJECT OFFICER: Mr. Ted Dzik,
DSN 992-1780
COMM 732-532-1780

ACQUISITION CATEGORY: IV
ACQUISITION PHASE: MS II Engineering Development
PE & LINE #: 64805 D097

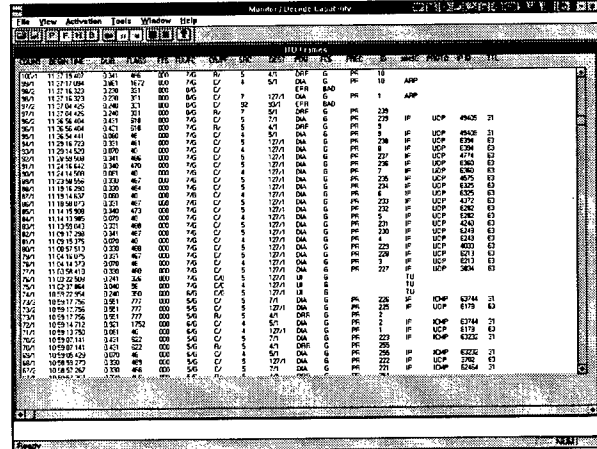

DESCRIPTION: Develop, evolve and apply the VMF & MIL-STD-188-220 Test Tools (VTT/PTT), providing the capability to validate architectural integrity, improve system interoperability, verify/certify correct system implementation, and sustain fielded systems in compliance with the standards/protocols of the Joint/Army Technical Architectures. These tools are a unique capability that provide the only available testers for VMF standards and 188-220 protocols, without which it would be impossible to test, validate and certify the information interchanged in the battlefield. Army/Joint interoperable VMF/188-220 system implementations, with reduced operational failures on the battlefield.

TRANSPORTATION CHARACTERISTICS/LIMITATIONS: Designed to run on typical Pentium/NT PCs, it is also hosted on similar class portable computers to readily deploy to user/developer/field sites.

HISTORICAL BACKGROUND:

- Mar 96 Developed initial VTT capability.
- Aug 96 Developed initial PTT Monitor/Decode capability.
- Jul 97 JITC Validation testing of VTT.
- FY97 Supported VMF/188-200 testing for Task Force XXI.

REQUIREMENTS DOCUMENT: JTA/JTA-A component standards support. Task Force XXI AWE.

TYPE CLASSIFICATION:

RELEASABLE TO SECURITY ASSISTANCE CUSTOMERS: Yes

EVENT SCHEDULE	FISCAL YEAR	QTR																												
		97				98				99				00				01				02								
Develop VTT Build 2		1	-----	-----	-----	-----	2	-----	-----	-----	-----																			
Develop VTT Build 3																														
Develop VTT Build 4																														
Develop VTT Build 5																														
Develop PTT Monitor/Decode v2		1	-----	-----	-----	-----	2	-----	-----	-----	-----																			
Develop PTT Conformance Tester v1		1	-----	-----	-----	-----	1	-----	-----	-----	-----																			
Develop PTT Conformance Tester v2																														
Develop PTT Network Analyzer v1																														
Develop PTT Network Analyzer v2																														
Support VMF message certification		1	-----	-----	-----	-----																								
Support 188-220 protocol certification		1	-----	-----	-----	-----																								

SYNOPSIS: THE VTT & PTT PROVIDE THE CAPABILITY TO TEST/CERTIFY VMF & MIL-STD-188-220 IMPLEMENTATIONS, WITHOUT WHICH IT WOULD BE IMPRACTICAL TO ENSURE INTEROPERABLE INFORMATION INTERCHANGED ON THE BATTLEFIELD.

SEC

VARIABLE MESSAGE FORMAT (VMF) & MIL-STD-188-220 STANDARDS

PROJECT OFFICER: Mr. Ted Dzik,
DSN 992-1780
COMM 732/532-1780

ACQUISITION CATEGORY: IV
ACQUISITION PHASE: MS II Engineering Development

PE & LINE #: 64805 D097

DESCRIPTION: Develop, evolve and configuration manage the suite of message standards and communications protocols to meet the Army's Force XXI battlefield digitization requirements for seamless connectivity and horizontal integration. Provides two key elements of the Army/Joint Technical Architectures -- the Variable Message Format (VMF) TIDP and the MIL-STD-188-220A protocol standard. Provides critical elements of the Joint/Army Technical Architectures to assure interoperable C4IEWS systems. Minimizes inconsistent interpretation of battlefield information by the warfighter. Integration with commercial Internet protocols. Responsive process to support C4IEWS systems implementation. Supports successful Force XXI AWEs.

TRANSPORTATION CHARACTERISTICS/LIMITATIONS:

HISTORICAL BACKGROUND:

- Mar 94 Initial VMF 15 message set for TF XXI.
- Nov 94 Army 188-220 () developed.
- Jan 95 Approved TF XXI VMF TIDP (Nov 94-41 messages).
- Apr 95 RFC 1770 developed for Selective Directed Broadcast.
- Jul 95 Joint 188-220A & 2045-47001 developed and approved.
- FY96 188-220 evolution to support implementers and TF XXI AWE.
- Mar 97 VMF/188-220 demonstrated in TF XXI AWE.
- Jul 97 188-220B version drafted, incorporating all changes leading up to TF XXI.

REQUIREMENTS DOCUMENT: JTA/JTA-A component standards. Army Science Board directive. Task Force XXI AWE.

TYPE CLASSIFICATION:

RELEASABLE TO SECURITY ASSISTANCE CUSTOMERS: No

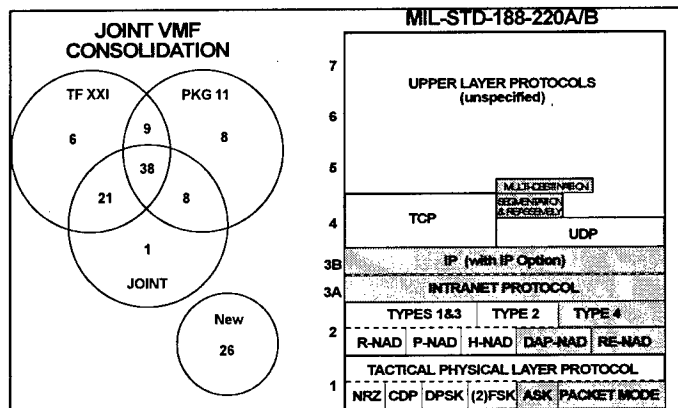

EVENT SCHEDULE	FISCAL YEAR	97	98	99	00	01	02
		1 2 3 4	1 2 3 4	1 2 3 4	1 2 3 4	1 2 3 4	1 2 3 4
Joint CNR WG Meetings	QTR	1 2 3 4	1 2 3 4	1 2 3 4	1 2 3 4	1 2 3 4	1 2 3 4
Joint VMF SG Meetings		1 2 3 4	1 2 3 4	1 2 3 4	1 2 3 4	1 2 3 4	1 2 3 4
TFXXI & DAWE demonstrations of standards		2	1				
Joint approval of 188-220B & 47001B			2				
Joint approval of all currently identified VMF messages			2				
Support VMF message test, changes & implementation		1-----	-----	-----	-----	-----	-----4
Support 188-220 testing, changes & implementation		1-----	-----	-----	-----	-----	-----4

SYNOPSIS: MESSAGE STANDARDS AND COMMUNICATIONS PROTOCOLS TO MEET THE ARMY'S FORCE XXI BATTLEFIELD DIGITIZATION REQUIREMENTS FOR SEAMLESS CONNECTIVITY AND HORIZONTAL INTEGRATION, PROVIDING TWO KEY ELEMENTS OF THE TECHNICAL ARCHITECTURES TO ASSURE INTEROPERABLE SYSTEMS AND MINIMIZES INCONSISTENT INTERPRETATION OF BATTLEFIELD INFORMATION BY THE WARFIGHTER.

SMC

SYSTEMS MANAGEMENT CENTER (SMC)

BASE SUPPORT TRUNKED RADIO SYSTEMS (BSTRS) PROGRAM

PROGRAM MANAGER: Martin R. Wall,
 DSN 987-6754
 COMM 732/427-6754
 FAX: 732/427-6751 DSN 987-6751
 E-Mail: bstrs@isma8.monmouth.army.mil

ACQUISITION CATEGORY: IV
ACQUISITION PHASE: III

PE & LINE #: N/A

DESCRIPTION: The Base Support Trunked Radio System (BSTRS) contract, DAAB07-96-D-L510, awarded on March 18, 1996 to Motorola, Inc. is a competitively awarded 5 year (base year & 4 options years) Indefinite Delivery/Indefinite Quantity (ID/IQ) contractual vehicle providing state-of-the-art, digital, commercial-off-the-shelf (COTS) base stations, mobile (vehicle mounted) and handheld radios, site surveys, design, integration, installation, testing, training, maintenance and technical data. The contract is open to DoD and any U.S. federal organization in CONUS (including Hawaii & Alaska) to enhance, upgrade or migrate an existing analog system to a digital trunked environment. A subsequent Task Order to contract DAAB07-92-Z-B056 providing site preparation work was awarded on October 1, 1996 to Raytheon E-Systems, through the Special Operations Forces Support Activity (SOFSA), located at the Lexington Army Bluegrass Army Depot, Government-Contractor (GOCO) facility.

TRANSPORTATION CHARACTERISTICS / LIMITATIONS: Fixed Plant Configuration.

HISTORICAL BACKGROUND:

Jul 94 Draft Solicitation.
 Apr 95 Released Solicitation.
 Jul 95 Begin Source Selection.
 Mar 96 Awarded BSTRS Contract to Motorola, Inc.
 Oct 96 Awarded Task Order to Raytheon E-Systems through SOFSA.
 Mar 97 Awarded first option.

REQUIREMENTS DOCUMENT: Draft Information Systems Mission Order (ISMO), B94R00607, Jun 94. HQ ISC Mission Need Statement (MNS) for BSTRS, 15 Apr 94. HQ ISC Operational Requirements Document (ORD), 15 Apr 94.

TYPE CLASSIFICATION: N/A

RELEASEABLE TO SECURITY ASSISTANCE CUSTOMERS: Yes

EVENT SCHEDULE	FISCAL YEAR QTR	97	98	99	00	01	02
		1 2 3 4	1 2 3 4	1 2 3 4	1 2 3 4	1 2 3 4	1 2 3 4
Contract Base Year		---2					
Option Year # 1		2-----	---2				
Option Year # 2			---2-----	---2			
Option Year # 3				2-----	---2		
Option Year # 4					2-----	---2	

SYNOPSIS: THE BSTRS AND RAYTHEON E-SYSTEMS (THROUGH SOFSA) CONTRACTS PROVIDE A TOTAL TURNKEY SOLUTION TO BUYING, LEASING OR LEASING WITH AN OPTION TO BUY TRUNKED RADIO SYSTEMS.

SYSTEMS MANAGEMENT CENTER (SMC)

LONG TERM LIFE CYCLE SUPPORT (LTLCS) for NORTEL, LUCENT Technologies and AGCS Electronic Digital Switching Systems

PROJECT MANAGER: Eric Swenson,
DSN 992-7976
COMM 732/532-7976
FAX 732/532-8499

ACQUISITION CATEGORY: III
ACQUISITION PHASE: IV Operations/Support

PE & LINE: N/A

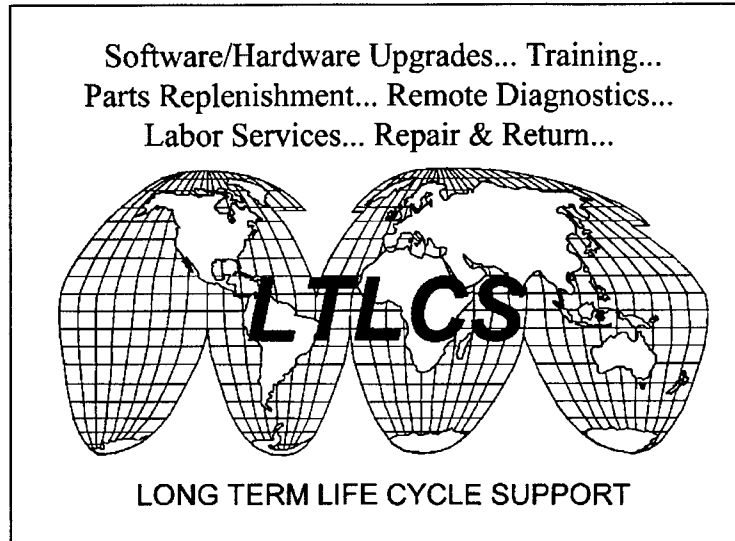

DESCRIPTION: LTLCS provides life cycle support to its customers by providing a contract vehicle from which customers (post, camp, station, installation, MACOM) can order the support services they need to manage, maintain, operate, and/or upgrade/enhance their telephone switching and network management systems. LTLCS support includes depot level maintenance (repair/return services), field service support, emergency technical assistance, remote diagnostics, publications updates, software upgrades, hardware upgrades, spares replenishment, training, engineering support and report generation. Northern Telecom, Inc. (NORTEL), AG Communication Systems (AGCS) and Lucent Technologies manufactured Electronic Digital Switch Systems include proprietary peripherals, Automatic Centralized Operations and Maintenance (ACOM) Systems, Telephone, Digital Conference Switching Systems (DCSS) ISDN applications and features and Emergency Action Consoles (EAC).

TRANSPORTATION CHARACTERISTICS / LIMITATIONS: N/A

HISTORICAL BACKGROUND:

Jun 92 NORTEL contract awarded.
Nov 93 AT&T/AGCS contract awarded.
Jul 96 Nortel Contract awarded.
May 97 AGCS contract awarded.
Jun 97 Nortel contract expired (1992-1997).

REQUIREMENTS DOCUMENT: MACOM Telephone Modernization Program, ISMO B83FUS408; Korea Telephone Upgrade, ISMO B82FKS398; Japan Telephone Upgrade, ISMO B85FJA419.

TYPE CLASSIFICATION: N/A

RELEASEABLE TO SECURITY ASSISTANCE CUSTOMERS: No

EVENT SCHEDULE	FISCAL YEAR QTR	97	98	99	00	01	02
		1 2 3 4	1 2 3 4	1 2 3 4	1 2 3 4	1 2 3 4	1 2 3 4
AGCS Contract - Award		3					
Lucent Contract - Award		4	1				

SYNOPSIS: THE LTLCS CONTRACTS PROVIDE SUPPORT AND SERVICES FOR THE INSTALLED BASE OF NORTEL, AGCS AND LUCENT ELECTRONIC DIGITAL TELEPHONE SWITCHING SYSTEMS.

PM, SCP

SYSTEMS MANAGEMENT CENTER (SMC)

PM, SMALL COMPUTER PROGRAM (SCP)

PRODUCT MANAGER: LTC Mary Fuller,
 DSN 987-6791
 COMM 732/427-6791
 FAX: 732/532-5185
 E-Mail: asqm-scp@isma8.monmouth.army.mil

ACQUISITION CATEGORY: III / IV
ACQUISITION PHASE: Various / All

PE & LINE: N/A

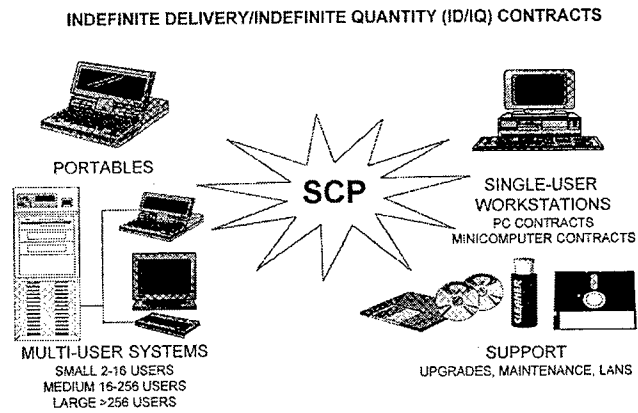

DESCRIPTION: The Product Manager, Small Computer Program provides a source of small and medium size computers (Hardware, Software, Networking, and Infrastructure support services) for the Army Power Projection Base, Strategic and Theater Tactical users. The Product Manager leads or participates in Army, Joint Service and Government Wide Agency ID/IQ Contracts and Blanket Purchase Agreements to support Army users, DOIMS and Program Managers. The Army's Small Computer Program provides a source of quality IMA products which can be procured by any Army activity in a timely and efficient manner to support the Army's Information Technology. SCP provides customer support in the form of: Standards-based ID/IQ contract and program management, ordering assistance and management, technical assistance, configuration management, and WWW home page. The SCP operates in a 1% fee-for-service environment.

TRANSPORTATION CHARACTERISTICS / LIMITATIONS: None

HISTORICAL BACKGROUND:

1985 SCP Office established.
 1985 - Present Customer orders exceed \$3.1B.

REQUIREMENTS DOCUMENT: ISMO # B95R00602

TYPE CLASSIFICATION: N/A

RELEASEABLE TO SECURITY ASSISTANCE CUSTOMERS: Yes

EVENT SCHEDULE	FISCAL YEAR QTR	97				98				99				00				01				02			
		1	2	3	4	1	2	3	4	1	2	3	4	1	2	3	4	1	2	3	4	1	2	3	4
Army Small Multiuser Computer-II Award									4																
Army Personal Computer-2 Award		1											1												
Army Portable Computer-2 Award		2											1												
Army Consolidated Enterprise Solutions Award			4										2												
Army Visual Information Products Award			4										2												
Microsoft Select Software Maintenance Award			4										2												
Army Enhanced Technology Award						1							2												

SYNOPSIS: THE SCP PROVIDES A SOURCE OF QUALITY IMA PRODUCTS WHICH CAN BE PROCURED BY THE ARMY, OTHER DEFENSE SERVICES, FEDERAL CIVIL AGENCIES, IN SUPPORT OF THE ARMY'S INFORMATION SYSTEMS TECHNICAL ARCHITECTURE AND THE DOD JOINT TECHNICAL ARCHITECTURE AS BASED ON THE COMMON OPERATING ENVIRONMENT OF THE DEFENSE INFORMATION INFRASTRUCTURE.

PM, DCASS

PM, DCASS

COMMON USER INSTALLATION TRANSPORT NETWORK (CUITN)

PRODUCT MANAGER: LTC R. Heuler,
 DSN 992-7912
 COMM 732/532-7912
 FAX: 732/532-7968
 DSN 992-7968
 E-Mail: heulerr@isma8.monmouth.army.mil

ACQUISITION CATEGORY: N/A
ACQUISITION PHASE: Fielding

PE & LINE #: BU4165

DESCRIPTION: CUITN is a PM, DDN managed program that provides an intelligent information infrastructure which supports high speed data transfer for P2C4I at Army posts, camps, and stations worldwide. It includes the hardware, software, and interfaces to both site internal and external data networks. The common user information infrastructure and backbone data networks implemented under this program provide the capability for connections to DPis, mainframes, E-Mail hosts, and essential P2C4I networks while providing access to gateways on the site and the DISN wide area network (WAN) external to the site. The intelligent information infrastructure provided by CUITN is supported by an intelligent, centralized, and automated capability to effect operations, administration, and maintenance thereof. CUITN implementations are open systems standards compliant and compatible with Army and DoD policies and standards for information infrastructure.

TRANSPORTATION CHARACTERISTICS / LIMITATIONS: N/A

HISTORICAL BACKGROUND:

- Dec 91 Information System Mission Order (ISMO) issued.
- 92-95 Fielded CUITN at Fort Bragg, NC, and Fort Hood, TX.
- 1995 Fielded CUITN at Fort Stewart, GA.
- 1996/97 Fielded CUITN at Fort Campbell, KY, Fort Lewis, WA, and Fort Bliss, TX.
- 1997 Fielding CUITN at Fort Drum, NY and Schofield Barracks, HI.

REQUIREMENTS DOCUMENT: ISMO B91A00585, Dec. 91.

TYPE CLASSIFICATION: N/A

RELEASEABLE TO SECURITY ASSISTANCE CUSTOMERS: Yes

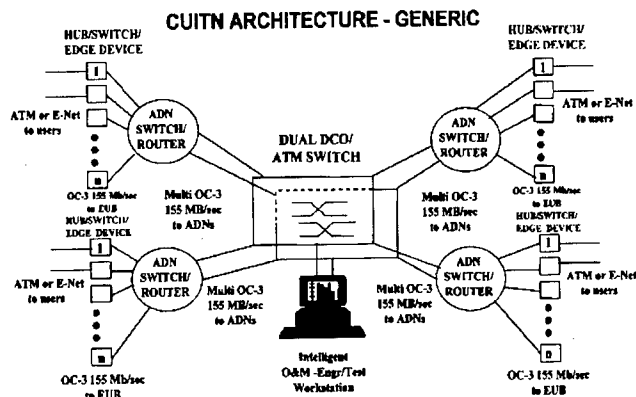

<u>EVENT SCHEDULE</u>	FISCAL YEAR		97	98	99	00	01	02
	QTR		1 2 3 4	1 2 3 4	1 2 3 4	1 2 3 4	1 2 3 4	1 2 3 4
Test			--1					
IOC at Stewart/Drum/Campbell			2					
New Surveys			-----2					
IOC at Lewis/Bliss			3					
Installation at Schofield/Drum			3-----	-----3				

SYNOPSIS: THE INTELLIGENT INFORMATION INFRASTRUCTURE THAT IS ENGINEERED, FURNISHED, INSTALLED, TESTED, AND PROVIDED TO THE WARFIGHTER UNDER THE CUITN EFFORT IS THE BEST AVAILABLE SOLUTION TO THE REQUIREMENT FOR INTEGRATED DATA TRANSPORT AND INFORMATION HANDLING AT SUSTAINING BASE POWER PROJECTION PLATFORMS IN TIMES OF PEACE AND WAR.

PM, DCASS

DIGITAL SWITCHED SYSTEMS MODERNIZATION PROGRAM (DSSMP)

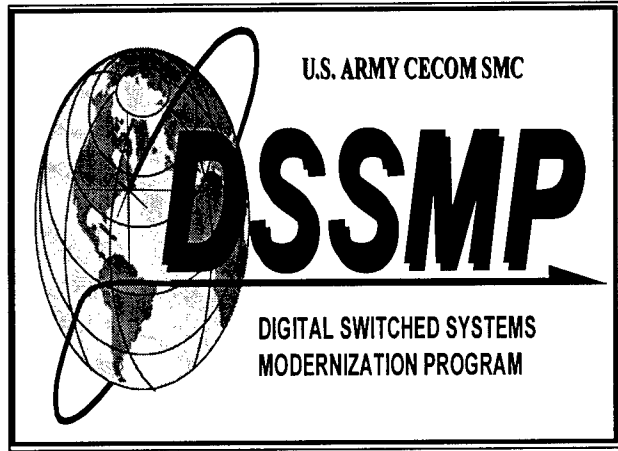

ASST PROJECT MANAGER: Eric Swenson,
 DSN 992-7976
 COMM 732/532-7976
 FAX DSN 992-9499
 COMM 732/532-8499

ACQUISITION CATEGORY: III
ACQUISITION PHASE: IV Operations/Support

PE & LINE #: N/A

DESCRIPTION: Nineteen (19) contracts were awarded to both large and small businesses on 30 June 1997. The DSSMP contracts will support all types of switches, to include but not be limited to switching systems manufactured by NORTEL, Lucent Technologies, Siemens and AG Communications Systems. The modernization contracts provide for installation, cutover, training, logistic support, as well as the capability to seamlessly integrate voice, data and transmission products into a single integrated telecommunicatios system. All of these solutions can be satisfied through either purchase, lease, lease with option to buy or Centrex service as specified in each delivery order. Having multiple contracts ensures that the government can obtain state-of-the-art tailored solutions for any type of switched systems at competitive prices throughout the life of the contracts. Once requirements are identified and funding is provided, all DSSMP contractors will be given a fair opportunity to compete for work within the scope of their contract. Once a contractor is selected, delivery orders will be issued on a firm fixed price basis.

TRANSPORTATION CHARACTERISTICS / LIMITATIONS: N/A

HISTORICAL BACKGROUND:

19 Apr 97 Solicitation Released.
 30 Jun 97 19 contracts awarded.

REQUIREMENTS DOCUMENT: Information Systems Mission Order (ISMO) 95RUS615, dated 7 Dec 95, Communications-Electronics Mission Order (CEMO) B85FJA419, dated 15 April 1985 and CDRUSAISC MSG, DTG 092030ZAUG94.

TYPE CLASSIFICATION: N/A

RELEASEABLE TO SECURITY ASSISTANCE CUSTOMERS: No

<u>EVENT SCHEDULE</u>	FISCAL YEAR QTR	97	98	99	00	01	02
		1 2 3 4	1 2 3 4	1 2 3 4	1 2 3 4	1 2 3 4	1 2 3 4
Solicitation Released		3					
DSSMP Contract awards		3					
Delivery Order #0001 to all Contractors		3					
Delivery Order #0002 to Harris Corp. (DMU Korea)		4					
Delivery Order #0002 to Halifax Corp. (Ft. Bragg, NC)		4					
Delivery Order #0002 to Bell Atlantic Corp. (Vint Hill Farms, VA)		4					

SYNOPSIS: THE DSSMP CONTRACTS WILL SUPPORT GLOBAL SWITCHED SYSTEM MODERNIZATION (NEW INSTALLATION, REUTILIZATION, UPGRADE, REPLACEMENT, CENTREX AND LEASE) REQUIREMENTS FOR THE ARMY AND WILL BE OPEN TO OTHER DOD AND FEDERAL AGENCIES.

PM, DCASS

MACOM TELEPHONE MODERNIZATION PROGRAM (MTMP)

ASST. PROJ. MGR: MAJ Demonia Dean,
 DSN 992-7911
 COMM 732/532-7911
 FAX: 732/532-3335
 E-Mail: deand@isma8.monmouth.army.mil

DESCRIPTION: The MTMP originated in 1982 as the CONUS Telephone Modernization Program (CTMP) with the objective of replacing nonsupportable, obsolete 1950's vintage, electro-mechanical switching systems at approximately 100 camps, posts & stations throughout CONUS. The primary objective of MTMP is to Engineer, Furnish, Install & Test (EFIT) and cutover a Commercial Off-The-Shelf (COTS) Integrated Services Digital Network (ISDN) telecommunications system. The scope of this effort includes removing existing systems, site preparation, EF&I digital switches, Outside Plant construction, installation of Telephone Management Systems (TMS), integration of Emergency Action Consoles (EACs), ensure compatibility with existing systems, provide training, initial logistical support & follow-on logistical support. The MTMP program is a complete turn key systems approach to an installation's telecommunications needs. CEMO # B83FUS408, 4 Mar 84, tasked the Project Manager, Defense Communications and Army Switched Systems (PM, DCASS) with implementing the program. Individual contracts for 5 of the most severely degraded systems were competitively awarded in FY83 during Phase I of the program. Subsequent analysis of the magnitude of the Army's requirements dictated that a coordinated, long range acquisition approach be utilized. MTMP was approved by the Under Secretary of the Army as a Stable Annual Investment for Renewal of Systems (STAIRS) program. As such, the program was to receive \$40-50 Million annually. It was planned that Phase II of the program would contract for upgrades of the remaining MTMP Priority List sites & provide them with an initial operating capability with the funds available. After sites received their initial upgrade, they could then be revisited in the outyears during Phase III to provide system expansion/augmentation & technology insertion as evolving requirements dictate. Severe funding decrements forced an extension of the schedule. The schedule for initial upgrades has been extended 7 years & will continue through FY01. Due to changes in site priority, mission and BRAC impacts, it is anticipated that certain sites will be revisited for Phase III expansion and augmentation before some sites receive their initial Phase II upgrade.

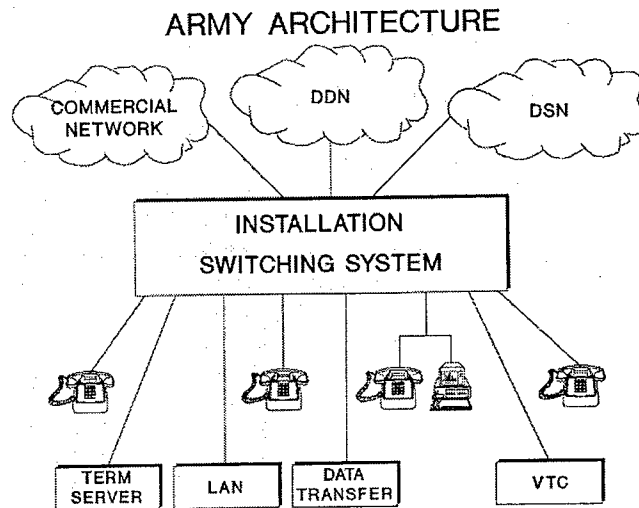

HISTORICAL BACKGROUND: The CTMP 83, 84 & 85 sites have been upgraded to digital voice switches. CTMP 86 & 87 sites are providing integrated voice and data capability and are upgradeable to ISDN. The MTMP IDIQ/T&M ten year contract was awarded 30 Sep 91 and is providing fully capable ISDN switches.
 CTMP Program Status: (CTMP 83, 84, 85, 86, 87 Contracts) 53 Sites Cutover / 53 Sites Accepted
 MTMP Program Status: (MTMP IDIQ/T&M Contract)
 35 Sites on contract / 30 Sites Cutover (incl. expansions) / 27 Sites Accepted.

REQUIREMENTS DOCUMENT: USACC CEMO 138FWSH08 dated 4 Mar 83.

RELEASEABLE TO SECURITY ASSISTANCE CUSTOMERS: No

MTMP GENERIC IMPLEMENTATION SCHEDULE	MONTHS																			
	1	2	3	4	5	6	7	8	9	10	11	12	13	14	15	16	17	18	19	20
Delivery Order	Δ																			
Site Survey Report		Δ	Δ																	
Drawings: 60%				Δ																
" 95%					Δ															
" 100%						Δ														
Site Prep						Δ	=====	Δ												
Outside Cable Const.						Δ	=====	Δ												
Switch Inst.								Δ	=====	Δ										
Data Base Gathering, Verf										Δ	=====	Δ								
Testing: Phase I												Δ	==	Δ						
" Phase II														Δ	=	Δ				
" Phase III																	Δ	=	Δ	
Cutover																				Δ

SYNOPSIS: THE MTMP PROGRAM IS A COMPLETE TURN KEY SYSTEMS APPROACH TO AN INSTALLATION'S TELECOMMUNICATIONS NEEDS.

PM, DCASS

Outside Cable Rehabilitation Contract

OUTSIDE CABLE REHABILITATION PROGRAM (OSCAR)

PROGRAM MANAGER: Mr. Craig Powderly (Acting),
 DSN 992-7996
 COMM 732/532-7996
 FAX 732/427-6659
 E-Mail: powderlc@isma8.monmouth.army.mil

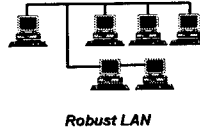
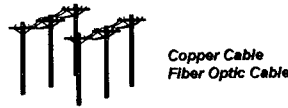

ACQUISITION CATEGORY: IV
ACQUISITION PHASE: III

PE & LINE #: MU2Z

DESCRIPTION: The Outside Cable Rehabilitation (OSCAR) Program provides for the repair, rehabilitation and upgrade of Army installations outside cable distribution plants. It is a comprehensive program for implementing installation connectivity at posts, camps, and stations in CONUS, Alaska, Hawaii, Puerto Rico and Panama. The OSCAR contract (DAEA32-96-D-0001) was awarded on 14 February, 1996 to GTE, Government Systems. The ID/IQ firm fixed price contract is a vehicle for acquiring cable, associated cable hardware, networking equipment, electronic components and logistics support for installation, by the contractor at Army sites or other DoD organizations.

TRANSPORTATION CHARACTERISTICS / LIMITATIONS: N/A

HISTORICAL BACKGROUND:

- Aug 93 Information System Mission Order (ISMO) issued.
- Feb 95 Released OSCAR RFP.
- May 95 Received Proposals.
- Feb 96 Awarded OSCAR contract.
- May 96 GTE initiated first implementation efforts at Ft. Stewart, GA.

REQUIREMENTS DOCUMENT: HQ ISC Information System Mission Order (ISMO), B94R08599, Aug 93.

TYPE CLASSIFICATION: N/A

RELEASEABLE TO SECURITY ASSISTANCE CUSTOMERS: No

EVENT SCHEDULE	FISCAL YEAR QTR	97				98				99				00				01				02			
		1	2	3	4	1	2	3	4	1	2	3	4	1	2	3	4	1	2	3	4				
Ft. Hood, TX - Implementation						1																			
Ft. Stewart, GA - Implementation						1																			
Ft. Campbell, KY - Implementation									2																
Ft. Bliss, TX - Implementation									1																
Ft. Lewis, WA - Implementation									1																
Ft. Drum, NY - Implementation		1							3																
Schofield Barracks, HI - Implementation Phase I		2							1																
Schofield Barracks, HI - Implementation Phase II									2																

SYNOPSIS: THE OSCAR PROGRAM PROVIDES THE CONTRACTUAL VEHICLE FOR DOD SITES IN THE UNITED STATES, PUERTO RICO AND PANAMA TO MODERNIZE THEIR INFORMATION SYSTEM INFRASTRUCTURE WITH STATE-OF-THE-ART COMMERCIAL-OFF-THE-SHELF (COTS) EQUIPMENT.

PM, DCATS

PM, DCATS

**AN/FGQ-13, SMART MULTI-CIRCUIT
TERMINAL (SMCT)**

PROJECT MANAGER: Mr. Harvey Slovin,
DSN 992-7920
COMM 732/532-7920

ACQUISITION CATEGORY: III
ACQUISITION PHASE: MS IV Operation/Support

PE & LINE #: BB8509

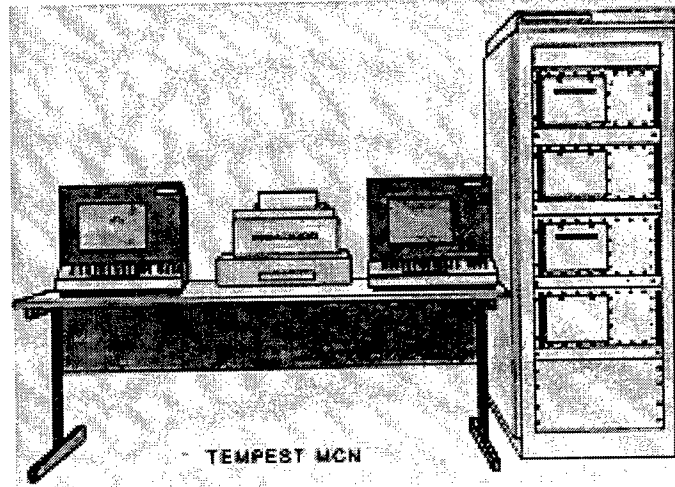

DESCRIPTION: The SMCT is an automated system which provides consolidation of the numerous control/coordination teletype requirements of the Terrestrial Critical Control Circuit (TCCC) through termination of each circuit on a display keyboard terminal and printer. It provides reliable time tagged communications with message routing capabilities in a clear or encrypted environment. SMCT is composed of two Central Processing Units, two Mass Memory (Disks), two Keyboards, four Video Display Units, and Printer.

TRANSPORTATION CHARACTERISTICS / LIMITATIONS: None.

HISTORICAL BACKGROUND:

- May 85 Implementation strategy of SMCT. Members were DA, AMC and SATCOM. Recommendation was for DA to direct SATCOMA to MIPR \$6.3M to DCA with AMC concurrence.
- Jun 85 AMC Msg 261900ZJUN85 directed SATCOM to MIPR \$6.3M to DCA for procurement of SMCT.
- Jul 85 ED contract awarded by DCA.
- Feb 86 ED contract awarded by DCA for additional models.
- Sep 87 Production contract awarded by DCA for fifteen SMCT II.
- Aug 90 Fielding Completed.

REQUIREMENTS DOCUMENT: DSCS Program Plan FY86-90.

TYPE CLASSIFICATION: 1985 Standanrd.

SYNOPSIS: SMCT IS A MICROPROCESSOR BASED SYSTEM USED TO PROVIDE FULL DUPLEX SECURE RESERVED COMMUNICATIONS BETWEEN ALL DEFENSE SATELLITE COMMUNICATIONS SYSTEM (DSCS) CONTROL FACILITIES.

PM, DCATS

**AN/FSC-78/79, HEAVY TERMINAL and
AN/GSC-39(V)2, MEDIUM TERMINAL (HT/MT)
MODERNIZATION PROGRAM**

PRODUCT MANAGER: Mr. Harvey Slovin,
DSN 992-7920
COMM 732/532-7920

PRODUCT MANAGER: Mr. Daniel M. Domogala,
DSN 992-9728 x 5819
COMM 732/532-9728 x 5819

ACQUISITION CATEGORY: III
ACQUISITION PHASE: MS III Production/Deployment

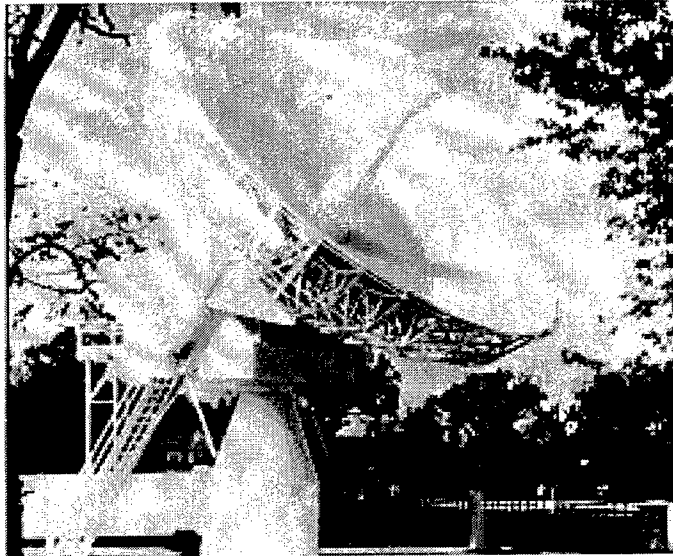

PE & LINE #: SSN: BB8416

DESCRIPTION: The AN/FSC-78 and AN/FSC-79 Heavy Terminals (HTs) and AN/GSC-39(V)2 Medium Terminals (MTs) have operated as part of the Defense Satellite Communications Systems (DSCS) satellite network since the mid-1970s and have surpassed their design life of 15 years. The modernization effort will provide for the upgrade of aging electronics in the HTs and MTs so that all DSCS Super High Frequency (SHF) strategic earth terminals will use common electronics and logistics support. It encompasses the equipment from the antenna interface to the communications and control subsystem interfaces. The result will extend the life of the terminals for another 15 years, increase readiness, reduce training and logistics support, conserve energy and improve maintainability.

TRANSPORTATION CHARACTERISTICS / LIMITATIONS: None.

HISTORICAL BACKGROUND:

Jun 89 DSCS Program Plan FY91-95 established requirement for the HT/MT Modernization DOD Tri-Service Program.
Jan 91 Milestone III IPR approval to proceed with procurement and application of the materiel change.
Mar 92 Production contract award to procure HTs.

REQUIREMENTS DOCUMENT: DSCS Program Plan FY91-95.

TYPE CLASSIFICATION: AN/FSC-78B(V) May 1997 Standard. AN/GSC-39B May 1997 Standard.

RELEASEABLE TO SECURITY ASSISTANCE CUSTOMERS: No

SYNOPSIS: HT/MT MOD KITS WILL PROVIDE FOR THE UPGRADE OF AGING ELECTRONICS IN THE HEAVY TERMINALS/MEDIUM TERMINALS SO THAT ALL DSCS SHF STRATEGIC EARTH TERMINALS WILL USE COMMON ELECTRONICS AND LOGISTICS SUPPORT.

PM, DCATS

**AN/FSC-91, SATELLITE CONFIGURATION
CONTROL ELEMENT (SCCE)**

PROJECT MANAGER: Mr. Harvey Slovin,
DSN 992-7920
COMM 732/532-7920

ACQUISITION CATEGORY:
ACQUISITION PHASE: IV

PE & LINE #: BB8509

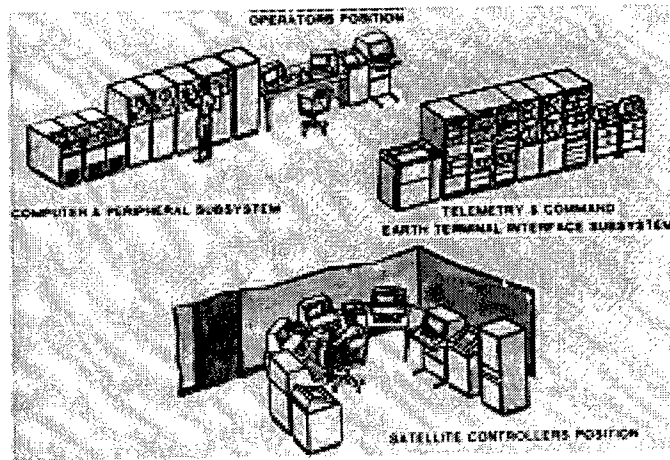

DESCRIPTION: The primary function of SCCE is to provide operational command and control of the Defense Satellite Communications System III (DSCS III) satellites to satisfy real-time user requirements. It is capable of jammer detection, location and mulling. Using the telemetry tracking and command channel, the SCCEs generate commands and command sequences which reconfigures DSCS III satellite channels and antenna beam allocations, and control COMSEC equipment. SCCEs will be linked with the DSCS III satellites by existing satellite earth terminals via an "SCCE - Earth Terminal interface."

TRANSPORTATION CHARACTERISTICS / LIMITATIONS: None.

HISTORICAL BACKGROUND:

Sep 82	First Production contract awarded for Serial Number (SN) 4 and 5.
Sep 83	Production contract awarded for SN 6 and 7.
Dec 83	Option exercised for SN 8 and 9.
Dec 84-May 92	SN 4-9 were fielded. (Fielding completed)
Jul 95	Computer upgrades for SCCE.

REQUIREMENTS DOCUMENT: Defense Satellite Communications System Program Plan as approved by Assistant Secretary of Defense (C31).

TYPE CLASSIFICATION: Limited production, Mar 82.

SYNOPSIS: SCCE PROVIDES OPERATIONAL COMMAND AND CONTROL OF DSCS III SATELLITES TO SATISFY REAL-TIME USER REQUIREMENTS.

PM, DCATS

AN/FSC-96 and AN/GSC-51, DEFENSE SATELLITE COMMUNICATIONS SYSTEM FREQUENCY DIVISION MULTIPLE ACCESS CONTROL SUBSYSTEM (DFCS)

PROJECT MANAGER: Mr. Harvey Slovin,
DSN 992-7920
COMM 732/532-7920

ACQUISITION CATEGORY: III
ACQUISITION PHASE: MS IV Operations/Support

PE & LINE #: E7086

DESCRIPTION: The DFCS controls transmit power of Defense Satellite Communications System (DSCS) carriers and monitors earth terminal and satellite network status and performance. The Network Terminal, AN/GSC-51 is installed in strategic satellite communications terminals. The satellite network data collected from these stations is transmitted via a Satellite Control Circuit to one of two Network Control Terminals (AN/FSC-96 or NCTs). Power Control Commands are calculated and transmitted to the Network Terminals for adjustment of Carrier Transmit Power. The Satellite Links within the DSCS are normally operated with a link margin of at least six decibels to accommodate uncontrollable signal transmission fades. The DFCS automatically detects and compensates for these transmission fades allowing the link margins to be reduced. This reduction in link margin allows channel capacity of the spacecraft to be significantly increased.

TRANSPORTATION CHARACTERISTICS / LIMITATIONS: None.

HISTORICAL BACKGROUND:

- Aug 85 Production contract award.
- Jul 87 DFCS deliveries began.
- May 88 DFCS installations at strategic locations began.
- May 93 Materiel release.

REQUIREMENTS DOCUMENT: DSCS FY85-89 Program Plan, Mar 83.

TYPE CLASSIFICATION: Standard approved Feb 84.

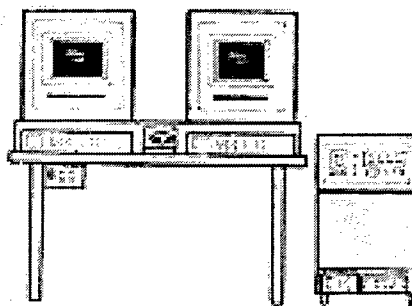

<u>EVENT SCHEDULE</u>	FISCAL YEAR		97	98	99	00	01	02
	QTR		1 2 3 4	1 2 3 4	1 2 3 4	1 2 3 4	1 2 3 4	1 2 3 4
Installation				1 2 4		2		

SYNOPSIS: DFCS IS A GROUND BASED SUBSYSTEM USED WITH EARTH TERMINAL EQUIPMENT FOR CONTROLLING TRANSMIT POWER OF DSCS CARRIERS AND FOR MONITORING EARTH STATION AND SATELLITE NETWORK STATUS AND PERFORMANCE.

PM, DCATS

**AN/FYQ-110 and AN/FSQ-142,
DSCS OPERATIONAL SUPPORT SYSTEM /
DSCS AUTOMATIC SPECTRUM ANALYZER
(DOSS/DASA)**

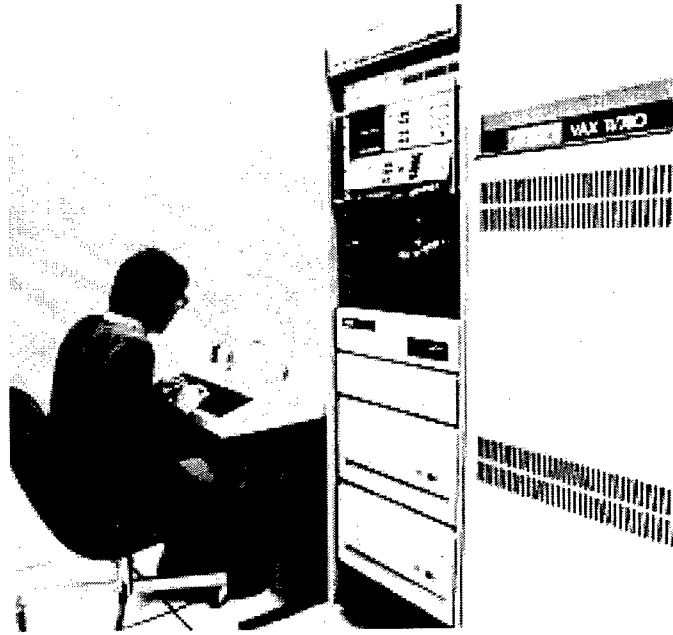

PROJECT MANAGER: Mr. Harvey Slovin,
DSN 992-7920
COMM 732/532-7920

ACQUISITION CATEGORY:
ACQUISITION PHASE: MS IV Operations/Support

PE & LINE #: BB509

DESCRIPTION: The DOSS provides computational support for the SATCOM Network Controller (and up to seven remote operators) to calculate Defense Satellite Communications System (DSCS) reconfiguration parameters in response to changing user requirements, changing network status, or changing environmental conditions. Contained within the DOSS is the Resource Allocation Software (RAS) consisting of the computer software which provides algorithms to support DOSS reconfiguration capabilities. The DASA is designed for operation connected directly to the DOSS or in a stand-alone mode, should this be required. The DASA provides control and data processing for an automatic spectrum analysis capability. DASA software accepts signal monitoring data from the Hewlett-Packard 8566B Spectrum Analyzer, computes various signal parameters based upon the current operational traffic configuration in the DOSS data base, and compares the measured values with the expected values generated by the DOSS Computer.

TRANSPORTATION CHARACTERISTICS / LIMITATIONS: None.

HISTORICAL BACKGROUND:

- Feb 79 Award for DOSS/DASA 1 and 2.
- May 84 Award for DOSS/DASA 3 and 4.
- Aug 84 Award for upgrade to existing DOSS/DASA systems.
- Mar 87 DOSS/DASA 5 and 6 definitized (\$9M).
- Sep 88 Awarded contract for DOSS/DASA 7 through 12.
- Feb 92 Awarded contract to retrofit DOSS/DASA VAX 8250 computer.
- May 93 Installed last 8250 upgrade.
- Apr 94 Awarded DIMS Material Change Contract.
- May 97 ALPHA upgrade fieldings completed.

REQUIREMENTS DOCUMENT: DSCS Program Plan FY86-90 approved Mar 84.

TYPE CLASSIFICATION: Standard approved Oct 87.

EVENT SCHEDULE	FISCAL YEAR															
	97	98	99	00	01	02										
	QTR		QTR		QTR		QTR									
	1	2	3	4	1	2	3	4	1	2	3	4	1	2	3	4
DIMS ECP	-----3															

SYNOPSIS: DOSS PROVIDES COMPUTATIONAL SUPPORT FOR THE SATCOM NETWORK CONTROLLER TO CALCULATE DSCS RECONFIGURATION PARAMETERS. DASA PROVIDES CONTROL AND DATA PROCESSING FOR AN AUTOMATIC SPECTRUM ANALYSIS CAPABILITY INTEGRATED WITHIN THE DOSS.

PM, DCATS

**AN/GSC-49(V)1, (V)2, and (V)3, JAM
RESISTANT SECURE COMMUNICATIONS
(JRSC) TERMINALS**

PROJECT MANAGER: Mr. Harvey Slovin,
DSN 992-7920
COMM 732/532-7920

PRODUCT MANAGER: Mr. Daniel M. Domogala,
DSN 992-9728 x 5819
COMM 732/532-9728 x 5819

ACQUISITION CATEGORY: III
ACQUISITION PHASE: MS III Production/Deployment

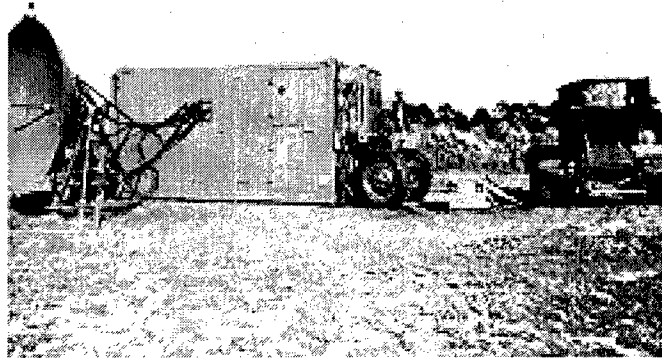

PE & LINE #: BA8300

DESCRIPTION: JRSC is an add-on to the Defense Satellite Communications System (DSCS) resulting from the Secretary of Defense requirement to improve Worldwide Military Communication Command and Control Systems (WWMCCS) capability of jam resistant secure communications via satellite. JRSC consists of Super High Frequency (SHF) Satellite Terminals packaged to satisfy JRSC peculiar requirements.

TRANSPORTATION CHARACTERISTICS / LIMITATIONS: Shelter without mobilizers: L = 244.5", W = 96", H = 96", Weight = 13,885.5 lbs; Shelter with mobilizers: L = 306", W = 96", H = 114", Weight = 18,635.5 lbs.

HISTORICAL BACKGROUND:

- Sep 80 Production contract award.
- Mar 84 First Unit Equipped.
- Jun 84 Initial Operational Capability.
- Dec 86 Last two terminals delivered.
- Nov 95 Upgrade Installation began.

REQUIREMENTS DOCUMENT: DSCS Program Plan - FY91-95.

TYPE CLASSIFICATION: Standard approved Aug 80.

RELEASEABLE TO SECURITY ASSISTANCE CUSTOMERS: No

<u>EVENT SCHEDULE</u>	<u>FISCAL YEAR</u>		97	98	99	00	01	02
	<u>QTR</u>		1 2 3 4	1 2 3 4	1 2 3 4	1 2 3 4	1 2 3 4	1 2 3 4
Contractor Installations			-----	-----4				

SYNOPSIS: JRSC PROVIDES JAM RESISTANT, SECURE COMMUNICATIONS ADD-ON FOR WWMCCS.

PM, DCATS

**AN/GSC-52(V), STATE-OF-THE-ART MEDIUM
TERMINAL (SAMT)**

PROJECT MANAGER: Mr. Harvey Slovin,
DSN 992-7920
COMM 732/532-7920

PRODUCT MANAGER: Mr. Daniel M. Domogala,
DSN 992-9728 x 5819
COMM 732/532-9728 x 5819

ACQUISITION CATEGORY: III
ACQUISITION PHASE: MS IV Operations/Support

PE & LINE #: BB8416

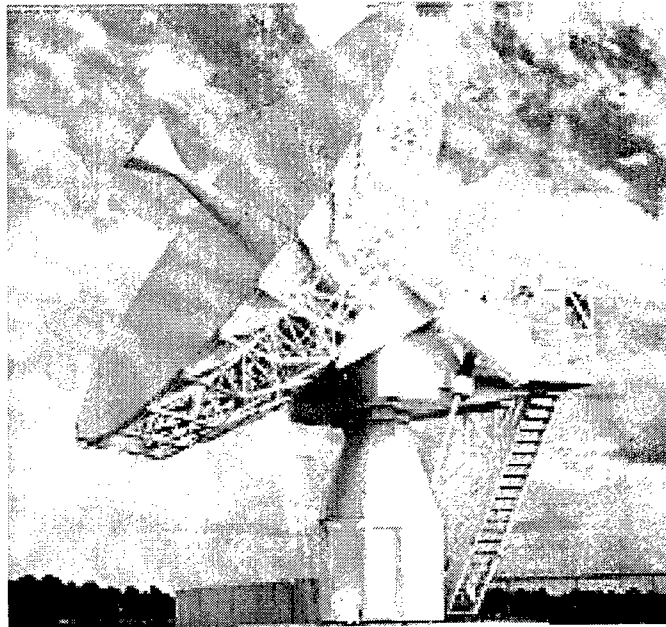

DESCRIPTION: SAMT is a high-capacity, medium sized Super High Frequency (SHF) Satellite Communications Terminal designed to operate in the DSCS satellite network. The terminals will be operated by the various services under the operational control of Defense Satellite Communications System (DISA). This new system is characterized by computer aided fault isolation, hierarchial control (remote console and external control possible) and automatic equipment switch-over to redundant equipment with High-Altitude Electromagnetic Pulse (HEMP) protection in vans or fixed site buildings. SAMT includes a 38 foot OE-371/G antenna.

TRANSPORTATION CHARACTERISTICS / LIMITATIONS: SAMT is transportable by air, land, and sea. Weight of AN/GSC-52(V2) Vanized Operations Group is 37,174 lbs. Dimension of Van is 8' x 36'.

HISTORICAL BACKGROUND:

- Jan 81 DSCS FY83-87 Program Plan approved by an Assistant Secretary of Defense (ASD) memorandum.
- Sep 82 Production contract awarded.
- Dec 85 First Unit Equipped.
- Jul 86 MOA signed by USAISEC and USASATCOMA for installation of system numbers 10 - 39.
- Dec 86 Initial Operational Capability.
- Nov 88 Production phase completed; Thirty-six terminals are installed and operational. three terminals remain in storage to be deployed at a future date.

REQUIREMENTS DOCUMENT: Defense Information Systems Agency (DISA). Defense Satellite Communications System (DSCS) Program Plan FY93-98.

TYPE CLASSIFICATION: Standard approved Aug 82.

EVENT SCHEDULE	FISCAL YEAR		97	98	99	00	01	02
	QTR		1 2 3 4	1 2 3 4	1 2 3 4	1 2 3 4	1 2 3 4	1 2 3 4
Product Improvements:								
Beason Tracking System			-----3					
Cesium Standard Upgrade			--1					
GSC-52 Modernization				2-----				

SYNOPSIS: SAMT IS A HIGH-CAPACITY MEDIUM SIZED SHF SATCOM TERMINAL TO OPERATE IN THE DSCS NETWORK.

PM, DCATS

**AN/TSQ-172, CONTINGENCY SATELLITE
CONFIGURATION CONTROL ELEMENT
(CSCCE)**

PROJECT OFFICER: Mr. Harvey Slovin,
DSN 992-7920
COMM 732/532-7920

ACQUISITION CATEGORY: III
ACQUISITION PHASE: MS IV Operation/Support

PE & LINE #: BB8509

DESCRIPTION: The CSCCE is the portion of the Contingency DSCS Operations Control System (CDOCS) that is responsible for Command, Control, Telemetry processing, and status monitoring for anyone of three designated DSCS III Satellites during a crisis or contingency environment. The major functions of the CSCCE are to monitor and assess overall satellite performance, to detect satellite anomalies, to execute housekeeping operations. ORBIT determination and ephemeris generation, plan/execute stationkeeping, configuration control of the DSCS III Communications payload, and uplink jammer detection and location.

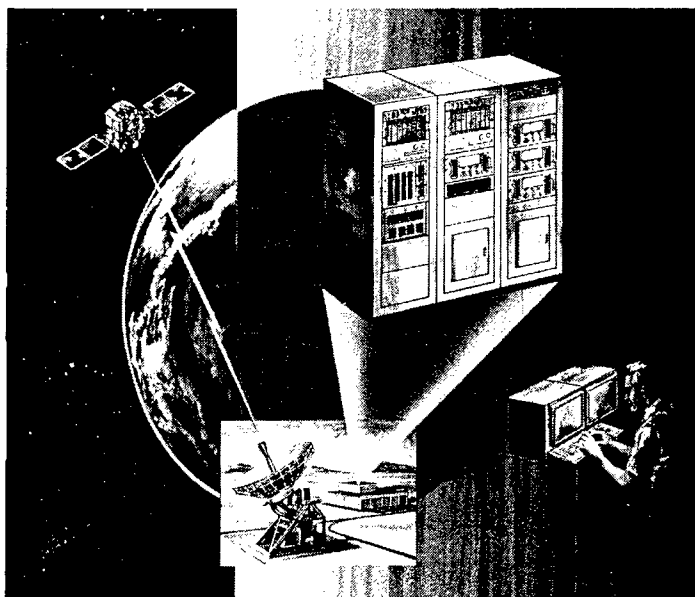

TRANSPORTATION CHARACTERISTICS / LIMITATIONS: None.

HISTORICAL BACKGROUND:

Dec 88 Contract Award.
Apr 90 Software Critical Design Review (CDR).
Dec 90 Hardware Critical Design Review (CDR).
Dec 91 First Article Test (FAT).
Aug 92-Sep 93 Fielding.

REQUIREMENTS DOCUMENT: DSCS Program Plan FY88-92.

TYPE CLASSIFICATION: Limited Production, Urgent 30 Apr 87.

SYNOPSIS: CSCCE IS THE PORTION OF THE CONTINGENCY DSCS OPERATIONS CONTROL SYSTEM (CDOCS) THAT IS RESPONSIBLE FOR COMMAND, CONTROL, TELEMETRY PROCESSING, AND STATUS MONITORING FOR ANY ONE OF THREE DESIGNATED DSCS III SATELLITES DURING A CRISIS OR CONTINGENCY ENVIRONMENT.

PM, DCATS

**DEFENSE SATELLITE COMMUNICATIONS
SYSTEM ELECTRONIC COUNTER COUNTER-
MEASURES CONTROL SUBSYSTEM (DECS)**

PROJECT MANAGER: Mr. Harvey Slovin,
DSN 992-7920
COMM 732/532-7920

ACQUISITION CATEGORY: III
ACQUISITION PHASE: MS IV Operations/Support

PE & LINE #: BB8509

DESCRIPTION: The Defense Satellite Communications System (DSCS) Electronic Counter Counter Measure (ECCM) Control Subsystem (DECS) will provide automated control of the AN/USC-28 ECCM network to allow the most effective and efficient communications. This will ease the workload of the already overburdened network controllers and network terminal operators by performing line power monitoring and automated polling responses at the NTs. In addition, DECS will allow the ECCM network to operate in a stressed environment by alerting the network controller to the presence of a jammer or violator, analyzing the stress, and executing the proper network reconfiguration needed to null the effects of the stress.

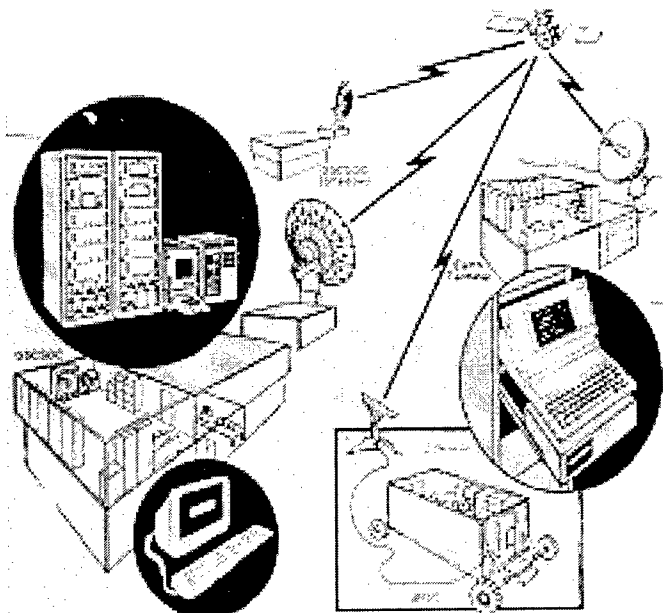

TRANSPORTATION CHARACTERISTICS / LIMITATIONS: None.

HISTORICAL BACKGROUND:

- Apr 86 Modified NDI acquisition approved (Milestone III).
- Jun 87 DCA directed specification change.
- Sep 87 DECS production award.
- Oct 92 Materiel release.
- Nov 92 Fielding began.
- Jul 94 Fielding completed.

REQUIREMENTS DOCUMENT: DSCS Program Plan.

TYPE CLASSIFICATION: Standard approved Apr 86.

SYNOPSIS: DECS PROVIDES AUTOMATED CONTROL OF THE ECCM NETWORK IN THE DSCS.

PM, DCATS

RBATSON

PROJECT MANAGER: Mr. Harvey Slovin,
 DSN 992-7920
 COMM 732/532-7920
 E-Mail: slovinh@isma8.monmouth.army.mil

ACQUISITION CATEGORY: III
ACQUISITION PHASE:

PE & LINE #: 0303142A D253

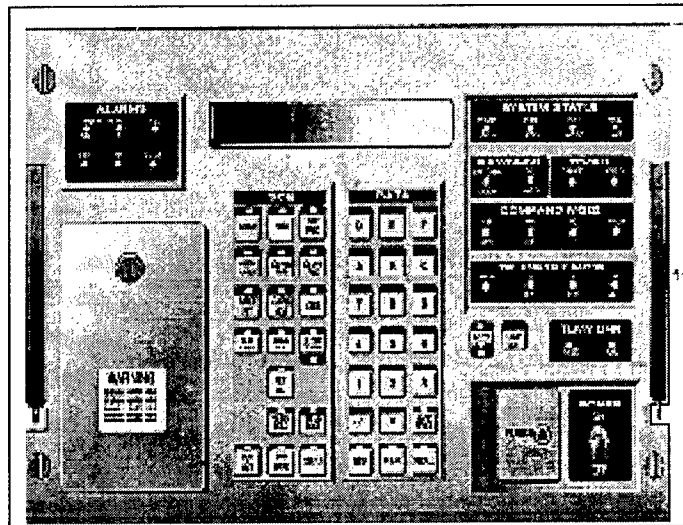

DESCRIPTION: The Replacement BATSON (RBATSON) Ground Operating Equipment (GOE) is a system that replaces the BATSON II which is the Communications Security (COMSEC) equipment in the Satellite Configuration Control Element (SCCE). The purpose of the COMSEC equipment is to provide cryptographic protection of the command and telemetry signals between the SCCEs and the Defense Satellite Communications System (DSCS) III satellite.

TRANSPORTATION CHARACTERISTICS / LIMITATIONS: None.

HISTORICAL BACKGROUND:

19 Dec 96 Basic Contract Award.

REQUIREMENTS DOCUMENT: Operational Requirements Document (ORD), 1 April 1995.

TYPE CLASSIFICATION:

<u>EVENT SCHEDULE</u>	FISCAL YEAR QTR	97	98	99	00	01	02
		1 2 3 4	1 2 3 4	1 2 3 4	1 2 3 4	1 2 3 4	1 2 3 4
Basic Contract		1					
Options 1 - 2 Awards			1	1			
Testing				1			
Installations					4		1

SYNOPSIS:

PM, DCATS

REPLACEMENT SATELLITE CONFIGURATION CONTROL ELEMENT (RSCCE)

PROJECT MANAGER: Mr. Harvey Slovin,
DSN 992-7920
COMM 732/532-7920

ACQUISITION CATEGORY III
ACQUISITION PHASE: MS I/II Demo/Val / EMD

PE & LINE: 0303142A D253

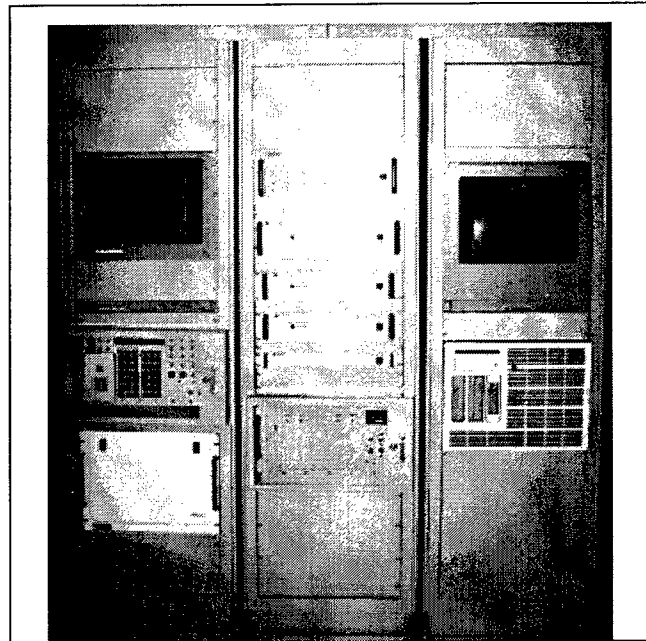

DESCRIPTION: The RSCCE will replace the Satellite Configuration Control Element (SCCE), which has a limited project life remaining with components becoming increasingly difficult to procure as failures increase. The RSCCE will utilize state of the art technology to provide operational control and monitoring of telemetry data from DSCS III satellites. This permits the DSCS Operations Control System (DOCS) to control the satellite platform and communications payload. The RSCCE will be functionally similar to the Contingency Satellite Configuration Control Element (CSCCE), which is comprised of three ruggedized hardware racks configured in a mobile van. The RSCCE is not required to be ruggedized and will be installed in fixed site DSCS Operation Centers (DSCSOC's) at worldwide locations. The RSCCE will include a Computer and Peripheral Subsystem (CPS) and a Telemetry and Command Subsystem (TCS). The RSCCE will be linked with the DSCS III satellites via existing satellite earth terminals through the Radio Frequency Interface System (RFIS).

TRANSPORTATION CHARACTERISTICS / LIMITATIONS: Fixed Site.

HISTORICAL BACKGROUND:

- 12 May 94 Acquisition Strategy Approved.
- 12 Jul 94 CECOM Acquisition Board.
- 15 Sep 94 Acquisition Decision Memorandum Approved Milestone I/II.
- Apr 95 NDI Contract Award.
- 12 Sep 95 Preliminary Implementation Review.
- 22 Jan 96 Critical Implementation Review.

REQUIREMENTS DOCUMENT: DSCS Program Plan.

TYPE CLASSIFICATION: Standard, Jan 98.

<u>EVENT SCHEDULE</u>	<u>FISCAL YEAR</u>											
	97		98		99		00		01		02	
	1	2	3	4	1	2	3	4	1	2	3	4
NDI Adaptation Phase				3								
Milestone III Decision				2								
Option 1-2-3 Awards				2			2					
Installations/Fieldings								4			2	

SYNOPSIS: THE RSCCE PROVIDES OPERATIONAL COMMAND & CONTROL OF THE DSCS III SATELLITE PLATFORM AND COMMUNICATIONS PAYLOAD.

PM DCATS

UNIVERSAL MODEM (UM)

PROJECT MANAGER: Mr. Harvey Slovin,
 DSN 992-7920
 COMM 732/532-7920

ASST PRODUCT MANAGER: LTC Michael Sidwell,
 DSN 992-9727 x 6828 COMM 732/532-9727 x 6828

ACQUISITION CATEGORY: III
ACQUISITION PHASE: Production

PE & LINE: BA8300

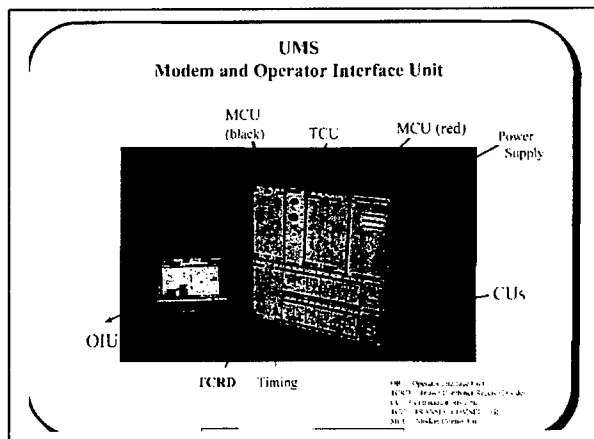

DESCRIPTION: The Universal Modem System (UMS), which includes a family of modems and a System Planning Computer (SPC) will provide survivable, Anti-Jam (AJ), Anti-Scintillation (AS), Low Probability of Exploitation (LPE), interoperable, Super High Frequency (SHF), command and control connectivity for military forces during all phases of conflict. The UMS will provide a means for strategic and tactical forces under the command of the United States (US), United Kingdom (UK), France, or North Atlantic Treaty Organization (NATO) to have interoperable secure voice and digital data satellite communications under worst case jamming and nuclear scintillation while using non processing transponders of the Defense Satellite Communications System (DSCS) II and III, NATO III and IV, SKYNET 4, and TELECOM 2 satellite systems. The Universal Modem will be configurable for installing at fixed sites, land mobile, ship based, and airborne terminals.

TRANSPORTATION CHARACTERISTICS / LIMITATIONS: None.

HISTORICAL BACKGROUND:

- Jun 89 Transferred from Air Force to Army.
- Oct 90 IPR.
- Mar 91 Contract Development Award.
- Jan 94 MCEB Guidance to build to "Commercial" standards.
- Jan 95 Revised MROC incorporating MCEB direction.
- Oct 96 Milestone III Decision/ADM signed.
- Feb 97 Contract awarded to Rockwell Collins, Inc.

REQUIREMENTS DOCUMENT: Defense Satellite Communications System (DSCS) Program Plan, Multi-Service Required Operational Capability (MROC) (dated January 1995).

TYPE CLASSIFICATION: N/A

EVENT SCHEDULE	FISCAL YEAR	97		98		99		00		01		02	
		QTR	1	2	3	4	1	2	3	4	1	2	3
Production Contract Award			2										
Performance Demo				2									
FAT						4		--1					
Technical Testing										2--3			
FOTE										3--4			
Fielding										4--			

SYNOPSIS: THE UNIVERSAL MODEM SYSTEM HAS BEEN DESIGNED FOR USE WITH US, UK AND NATO SHF SATELLITE SYSTEMS TO PROVIDE INTEROPERABILITY.

PM, FIREFINDER

PM, FIREFINDER

FIREFINDER SYSTEMS/PROGRAMS

PRODUCT MANAGER: LTC Thomas M. Cole,
DSN 987-5618
COMM 732/427-5618

PE & SSN #: BZ7325 - FIREFINDER, ELECTRONICS UPGRADE, ENHANCED FIREFINDER, ATG
MOBILITY IMPROVEMENT.

654270/DL18, VA8000 SHORTSTOP
644823/DL85, BA5100 FIREFINDER Block II

DESCRIPTION: FIREFINDER is comprised of the AN/TPQ-36 and AN/TPQ-37 Mortar and Artillery Locating Radars. The AN/TPQ-36 are fielded to both the Army and Marine Corps. These radars are organic to separate infantry and armor brigades, to the Target Acquisition Battery (TAB) at Division Artillery (Div Arty), and/or Corps Field Artillery Detachments. FIREFINDER radars are currently operational and are used in all military operations to include Operation Desert Shield/Storm and the Sustaining Force (SFOR) in Bosnia.

HISTORICAL BACKGROUND: Fielding and deployment of the AN/TPQ-36 and AN/TPQ-37 Radars is complete. Operational use and sustainment of fielded FIREFINDER continues.

PRODUCT IMPROVEMENTS TO FIREFINDER SYSTEMS: Several Materiel Changes/Product Improvements are in process.

AN/TPQ-36 MATERIEL CHANGES (MC):

AN/TPQ-36(V)8 Electronics Upgrade. This MC will improve the Operations Control Group (OCG), now called the Operations Central (OC), through the installation of state-of-the-art electronics including Common Hardware/Software (CHS) Lightweight Computer Unit Version 2 (LCU V2) equipment in the Lightweight Multipurpose Shelter (LMS). The upgrade is an open architecture design and will allow FIREFINDER to communicate on the digitized battlefield. The OC will also incorporate an Environmental Control Unit (ECU) and a Gas Particulate Filter Unit (GPFU). Major subsystems of the OC include an Operator Control Station (OCS), a Control/Display Terminal (CDT) and a radar processor. The OCS will serve as the man-machine interface and is a modern windows type display. Using the CDT, the operator will be able to control system operations from a site up to 100 meters remote from the shelter. The radar processor will perform all systems processing functions not assigned to the OCS. It will be reprogrammable and reconfigurable to maximize system performance under varying target and operating environment conditions. The new OCG will enhance the man-machine interfaces and electronics environment by providing 50 percent more interior space and improved environmental control. A full scale production contract was awarded in Aug 96 after a successful MS III Decision in Jun 96.

AN/TPQ-37 MATERIEL CHANGES (MC):

1. Antenna Transceiver Group (ATG) Mobility Improvement. This MC will improve the mobility of the AN/TPQ-37(V) ATG in sand, mud, and soft earth by applying a tracked suspension system to the M-1048 trailer. This will reduce ground contact pressure and drawbar pull force, and eliminate tire wear problems.
2. Enhanced FIREFINDER Block I. This MC upgrades mechanical deficiencies, incorporates improvements in the software, reduces the number of false locations, improves the reliability of the transmitter, increases the organic capability of C-130/C-141 transportability, and improves the survivability against ARMS. The software improvements will be provided to Ft. Sill Software Engineering Directorate for incorporation and testing in the Version 11 update to the FIREFINDER system software. Two reproduction survivability suites developed during Enhanced FIREFINDER Block I will be put into contingency storage.
3. FIREFINDER Block II. The FIREFINDER Block II program will improve performance of the AN/TPQ-37 by replacing the Antenna Transceiver Group (ATG). This is in response to the approved MNS for the Advanced FIREFINDER System and an approved ORD dated Sep 96. The new ATG will double the detection ranges of all targets, add a Tactical Ballistic Missile detection capability, increase the target throughput tenfold, increase mobility and transportability by C-130, and decrease the crew requirements from twelve (12) to nine (9). The program will leverage off the funded AN/TPQ-36(V)8 Electronics Upgrade program which will provide a common man-machine interface.

PM, FIREFINDER

**AN/TPQ-36, FIREFINDER MORTAR LOCATING
RADAR**

PRODUCT MANAGER: LTC Thomas M. Cole,
DSN 987-5618
COMM 732/427-5618

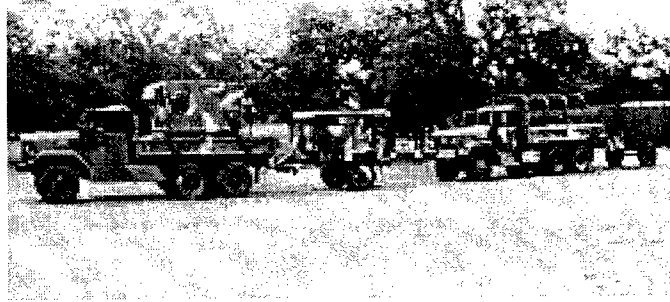

ACQUISITION CATEGORY: III
ACQUISITION PHASE: MS IV Operations/Support

PE & LINE #: SSN: BZ7325

DESCRIPTION: AN/TPQ-36 locates both enemy mortar and artillery weapons systems. It is composed of: Operations Control Group (OCG) mounted on an M-35 2-1/2 ton Truck; Antenna Transceiver Group mounted on an M-103 series Trailer; and, the AN/MJQ-25 power unit (two MEP-112s, 10 kilowatt, 400 hertz, diesel generators) mounted on an M-103 1-1/2 ton Trailer. Three AN/TPQ-36 radars are assigned to a division Target Acquisition Battery and are normally complemented by two AN/TPQ-37 Artillery Locating Radars. AN/TPQ-36 is a highly mobile phased-array radar which automatically and accurately locates mortars, artillery and short range rocket launchers. Materiel changes to increase mobility, decrease emplacement/displacement time, and incorporate electronics upgrades are in progress.

TRANSPORTATION CHARACTERISTICS / LIMITATIONS: No transportation issues exist for these systems.

HISTORICAL BACKGROUND:

Nov 71 Materiel need statement for Mortar Locating Radar by HQ DA.
Oct 73 Contract to HAC for five Engineering Development Models (EDMs).
Dec 77 Full Scale Production (FSP) approved; Materiel Needs Statement revalidated by HQ DA.
Dec 80 First Delivery; Conditional acceptance.
Jul 86 Production Complete (for U.S. Forces).
4QFY90 AN/TPQ-36 used to support Operation Desert Shield/Storm.

REQUIREMENTS DOCUMENT: Materiel Needs Statement with changes, 25 Oct 77.

TYPE CLASSIFICATION: Standard approved Oct 79.

RELEASEABLE TO SECURITY ASSISTANCE CUSTOMERS: Yes

SYNOPSIS: FIREFINDER AN/TPQ-36 IS A MORTAR AND ARTILLERY LOCATING RADAR.

PM, FIREFINDER

AN/TPQ-36, FIREFINDER MORTAR LOCATING RADAR, ELECTRONICS UPGRADE

PRODUCT MANAGER: LTC Thomas M. Cole,
 DSN 987-5618
 COMM 732/427-5618

ACQUISITION CATEGORY: III
ACQUISITION PHASE: MS III Production/Deployment

PE & LINE #: SSN: BZ7325 Modification Of In-Service Equipment (TACSURV)

DESCRIPTION: The AN/TPQ-36(V)8 Electronics Upgrade will improve the Operations Control Group (OCG) through the installation of state-of-the-art electronics and Common Hardware/Software (CHS) in the Lightweight Multipurpose Shelter (LMS). The upgrade is an open architecture design and will allow FIREFINDER to communicate on the digitized battlefield. The Operations Central (OC) (previously the OCG) will be mounted on an M1097 "Heavy" HMMWV which will tow the Antenna-Transceiver Group (ATG) on a modified M116A2E1 trailer. A second M1097 HMMWV will carry a palletized MEP-112A generator and will tow an M116A2E1 cargo trailer. A HMMWV reconnaissance vehicle (M998 or M1038) will tow a second ("back up") MEP-112A generator mounted on an M116A2E1 trailer. Major subsystems of the OC include an Operator Control Station (OCS), a Control/Display Terminal (CDT), radar processor, and shelter. The OCS will serve as the man-machine interface and is a modern windows type display. The CDT will allow the operator to command and control system operation from a remote site up to 100 meters from the shelter. The radar processor will perform all system processing functions not assigned to the OCS and will be programmable and reconfigurable to maximize system performance under varying target and operating environmental conditions. The LMS will enhance the man-machine interface and electronics environment by providing 50 percent more interior space.

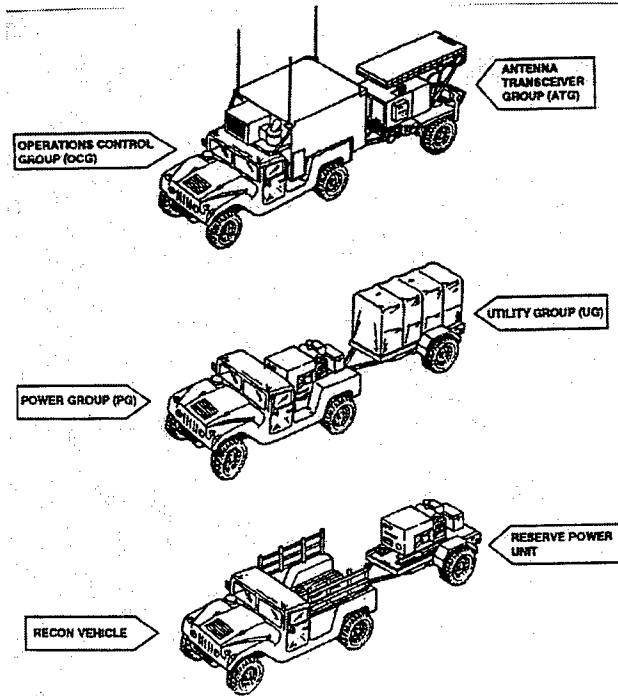

TRANSPORTATION CHARACTERISTICS / LIMITATIONS: Installed on HMMWV's, Roll-on/off C130 A/C UH-60 Transportable.

HISTORICAL BACKGROUND:

- Apr 92 AAE approved program initiation.
- Dec 92 LRIP Contract award.
- Jun 96 MS III Approved.
- Aug 96 Production contract award.

REQUIREMENTS DOCUMENT: Materiel Change 1-90-07-0016; Letter Requirement (TRADOC) USAFAS, ATSF-TSM-TA dated 13 Apr 92.

TYPE CLASSIFICATION: Standard, 2QFY96

RELEASEABLE TO SECURITY ASSISTANCE CUSTOMERS: Yes

EVENT SCHEDULE	FISCAL YEAR	97	98	99	00	01	02
		1 2 3 4	1 2 3 4	1 2 3 4	1 2 3 4	1 2 3 4	1 2 3 4
Production	QTR		3				
Production Acceptance Testing			1				
Initial Operational Capability (IOC)			3				

SYNOPSIS: AN/TPQ-36(V)8 FIREFINDER UPGRADE IS A MORTAR AND ARTILLERY LOCATING RADAR.

PM, FIREFINDER

**AN/TPQ-37, FIREFINDER ARTILLERY
LOCATING RADAR**

PRODUCT MANAGER: LTC Thomas M. Cole,
DSN 987-5618
COMM 732/427-5618

ACQUISITION CATEGORY: III
ACQUISITION PHASE: MS IV Operations/Support

PE & LINE #: SSN: BZ7325

DESCRIPTION: The AN/TPQ-37 is a mobile Phased Array Artillery Locating Radar System. The operations shelter is identical to that used with the AN/TPQ-36(V)5 and consists of an Operations Control Group mounted on an M-35 series Truck, and the MEP-115A, 60 kilowatt, 400 hertz Generator Set mounted on a 5-ton Truck. This truck also tows the Antenna Transceiver Group consisting of the Phased Array Antenna, Transmitter, Receiver and associated electronics mounted on the M-1048 Trailer, a 6-ton four wheel flatbed Cargo Trailer. Two AN/TPQ-37s are assigned to the Target Acquisition Battery of each division and employed with the AN/TPQ-36. The AN/TPQ-37 is larger than the AN/TPQ-36 and its target acquisition range is greater. The system uses a combination of radar techniques and computer controlled functions to detect and accurately locate enemy artillery and rocket weapons to permit rapid engagement with counterfire.

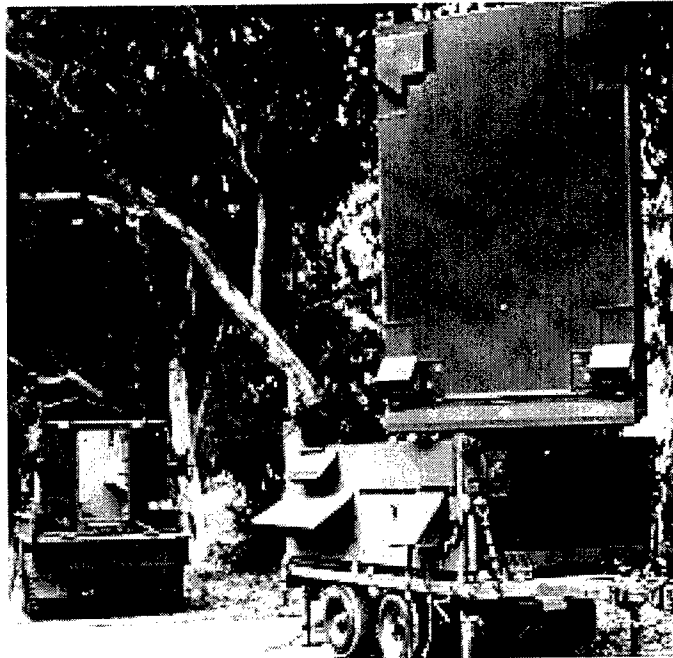

TRANSPORTATION CHARACTERISTICS / LIMITATIONS: No transportability issues exist.

HISTORICAL BACKGROUND:

Jun 72 DA approved Materiel Need Statement; contract Research and Development award.
Dec 76 Low Rate contract award.
May 81 Full Scale Production contract award.
Feb 83 Initial Operational Capability (IOC) complete, Europe.
Feb 86 Production complete for Army.
Apr 92 Last U.S. fielding.

REQUIREMENTS DOCUMENT: Mission Need Statement, 1 Jun 78.

TYPE CLASSIFICATION: Standard approved 18 Feb 81.

RELEASEABLE TO SECURITY ASSISTANCE CUSTOMERS: Yes

SYNOPSIS: AN/TPQ-37 IS A MOBILE PHASED ARRAY ARTILLERY LOCATING RADAR SYSTEM.

PM, FIREFINDER

AN/TPQ-37(V), ATG MOBILITY IMPROVEMENT PROGRAM

PRODUCT MANAGER: LTC Thomas M. Cole,
DSN 987-5618
COMM 732/427-5618

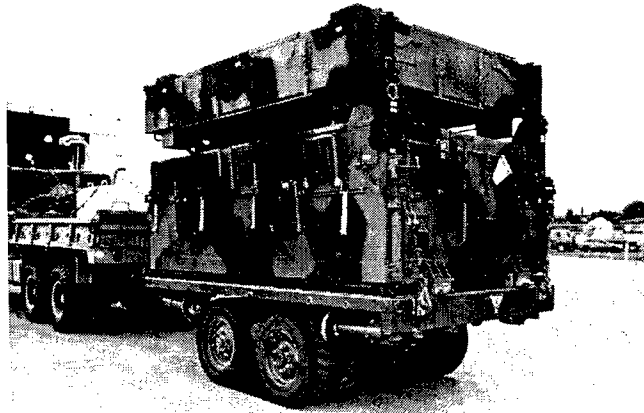

ACQUISITION CATEGORY: III
ACQUISITION PHASE: MS III Production/Deployment

PE & LINE #:

DESCRIPTION: This Mobility Improvement Program was initiated in response to mobility problems encountered in Operations Desert Shield/Storm. These problems included difficulty in moving the trailer through sand and improper tracking of the trailer behind the prime mover. This MC adapts a variant of M-200 trailer Tracked Suspension System (TSS) to the M1048 trailer which carries the Antenna Transceiver Group (ATG) of the AN/TPQ-37. In the pre-production phase two (2) TSS test kits were installed and tested on the M1048 trailer. (The primary components of the TSS modification kit are a walking beam suspension and reinforced rubber belts which wrap around the dual idler tires of the trailer). Testing demonstrated that TSS application provided a wider foot print for the M-1048 trailer which improved trailer mobility in off-road use and did not degrade performance on paved surfaces at highway speeds. Improvements using the TSS include: increased trafficability/mobility through soft dirt, mud and sand; better side-slope capability, less horse power required by the prime mover towing the trailer and better ride stability.

TRANSPORTATION CHARACTERISTICS / LIMITATIONS: The ATG Mobility Improvement will not change Transportation Characteristics of the End Item Radar.

HISTORICAL BACKGROUND:

- Mar 91 After Action Report, Saudi, 16-28 Feb 93, CMDNT, USAFAS, Fort Sill, OK.
- Jan-Feb 92 MOA and SOW with PM TRAILERS.
- May 92 Materiel Change approved.
- Oct 92 Materiel Change (Revised to include production) Approved.
- Apr 94 MS III Approval.
- Jul 94 Award of Production Contract.
- Mar 96 First Unit Equipped.

REQUIREMENTS DOCUMENT: MC #1-92-07-0001

TYPE CLASSIFICATION: N/A

RELEASEABLE TO SECURITY ASSISTANCE CUSTOMERS: Yes

<u>EVENT SCHEDULE</u>	FISCAL YEAR	97	98	99	00	01	02
		1 2 3 4	1 2 3 4	1 2 3 4	1 2 3 4	1 2 3 4	1 2 3 4
Fielding			--1				

SYNOPSIS: AN/TPQ-37(V) ATG MOBILITY IMPROVEMENT PROGRAM IMPROVES TRAILER MOBILITY IN OFF-ROAD USE AND DOES NOT DEGRADE PERFORMANCE ON PAVED SURFACES AT HIGHWAY SPEEDS.

PM, FIREFINDER

**AN/TPQ-37(V), ENHANCED FIREFINDER
BLOCK I**

PRODUCT MANAGER: LTC Thomas M. Cole,
DSN 987-5618
COMM 732/427-5618

ACQUISITION CATEGORY: III
ACQUISITION PHASE: MS III Production/Deployment

PE & LINE #: BZ7325

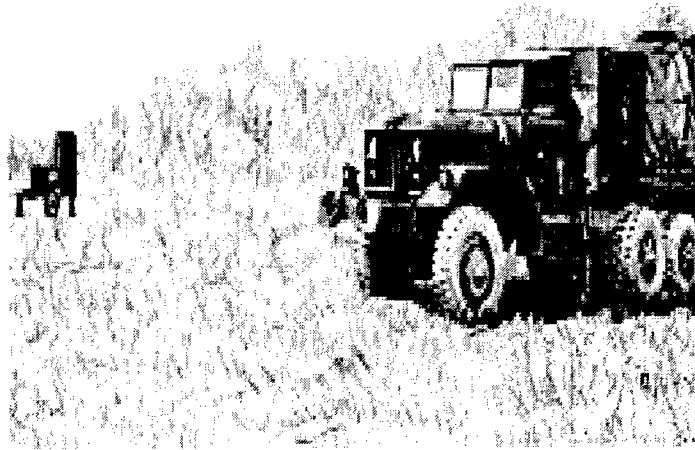

DESCRIPTION: This Block I Materiel Change incorporates mechanical upgrades to improve Reliability, Availability and Maintainability (RAM), it improves transportability, mobility, survivability and commonality with the AN/TPQ-36. Software improvements include reduced false locations and incorporation of a long range mode. Special features include a new, improved cooler, C-130 transportability kit, MAPS-Self survey, and a separate tape for Long Range Missile Detection Software. The system will be strategically deployable and operable at all levels of conflict.

TRANSPORTATION CHARACTERISTICS / LIMITATIONS: The FIREFINDER Block I is Ground Mobile Equipment with C-130 Roll on/Roll off Transportability for Rapid Deployment.

HISTORICAL BACKGROUND:

- Oct 92 Initial requirements defined.
- Feb 93 Block I Materiel change approved.
- Mar 93 Preproduction contract award.
- Jul 93 Critical design review.
- Apr 94 Testing Completed.
- Jun 94 Production Decision.
- Jun 94 Production Award.
- Mar 96 First Unit Equipped.

REQUIREMENTS DOCUMENT: Draft O&O Plan, Mar 91; Initial Block I EFF Conference, Oct 92; Materiel Requirements Letter, 6 Aug 93.

TYPE CLASSIFICATION: Standard.

RELEASEABLE TO SECURITY ASSISTANCE CUSTOMERS: Yes

<u>EVENT SCHEDULE</u>	FISCAL YEAR	97	98	99	00	01	02
		1 2 3 4	1 2 3 4	1 2 3 4	1 2 3 4	1 2 3 4	1 2 3 4
Fielding			1				

SYNOPSIS: NEW IMPROVED COOLING SYSTEM, LONG-RANGE SOFTWARE TAPE, MAPS SITE SURVEY, C-130 TRANSPORTABILITY KIT.

PM, FIREFINDER

FIREFINDER BLOCK II

PROJECT MANAGER: LTC Thomas M. Cole,
DSN 987-5618
COMM 732/427-5618

ACQUISITION CATEGORY: III
ACQUISITION PHASE: MS II
Engineering/Manufacturing Development

PE & LINE #: RDTE 64823 / DL85, OPA BA5100

DESCRIPTION: The FIREFINDER BLOCK II program will upgrade the Antenna Transmitter Group (ATG) of the AN/TPQ-37 Radar. This upgrade will double the range performance, improve the target throughput, mobility, transportability and survivability. The FIREFINDER BLOCK II will be capable of missile detection at maximum ranges of 150-300KM depending on the target radar cross section and will be capable of C-130 Roll-on/Roll-off transportability for rapid deployment. Crew size will be reduced. The program will also leverage off the AN/TPQ-36(V)8 Electronics Upgrade program by providing the same man-machine interface. The BLOCK II system will also be capable of simultaneous transmission of target launch point location information to theater missile defense assets such as JSTARS, UAV's, and active defense systems.

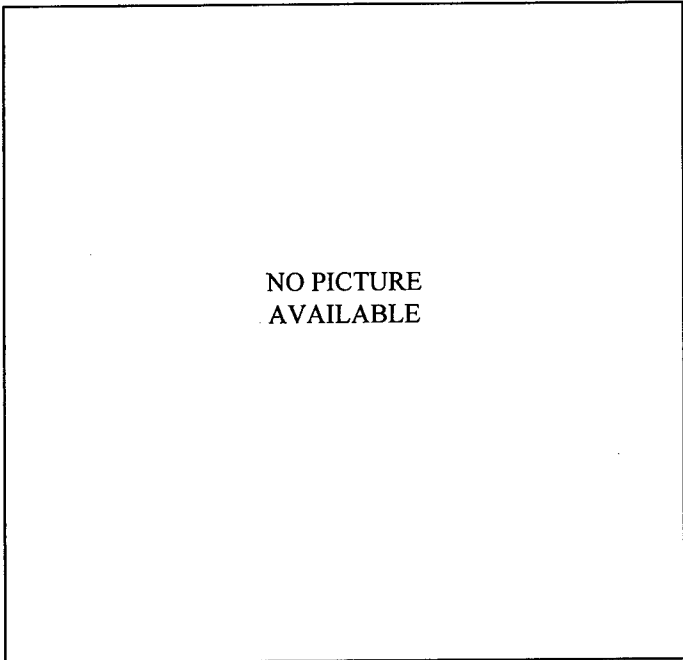

TRANSPORTATION CHARACTERISTICS / LIMITATIONS: The FIREFINDER BLOCK II system will be a ground mobile equipment with C-130 Roll on/Roll off transportability for rapid deployment.

HISTORICAL BACKGROUND:

REQUIREMENTS DOCUMENT: 4 Aug 93 - Mission Need Statement.
17 Aug 95 - ORD Approved Hqs, TRADOC.
25 Sep 96- ORD Approved HQDA.

TYPE CLASSIFICATION: TBD.

RELEASEABLE TO SECURITY ASSISTANCE CUSTOMERS: No

<u>EVENT SCHEDULE</u>	<u>FISCAL YEAR</u> QTR	97	98	99	00	01	02
		1 2 3 4	1 2 3 4	1 2 3 4	1 2 3 4	1 2 3 4	1 2 3 4
Obtain Milestone II Approval		4					
Release Solicitation			1				
Conduct Source Selection Evaluation			1-2				
Contract Award (EMD Qty 3)			2				
Development			2			3	

SYNOPSIS: UPGRADE THE AN/TPQ-37 ANTENNA TRANSMITTER GROUP TO INCREASE SYSTEM PERFORMANCE TO ADDRESS CURRENT THREAT IN A HIGHLY MOBILE, TRANSPORTABLE AND SURVIVABLE SYSTEM.

PM, FIREFINDER

SHORTSTOP

PROJECT MANAGER: LTC Thomas M. Cole,
DSN 987-5618
COMM 732/427-5618

ACQUISITION CATEGORY: III
ACQUISITION PHASE: MS II Demo/Validation

PE & LINE #: 64270 DL18

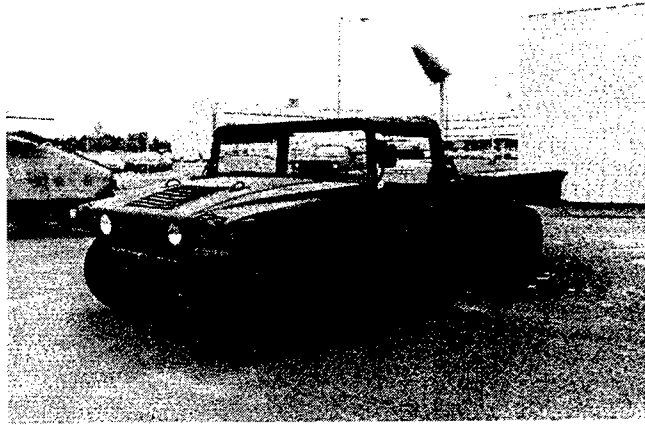

DESCRIPTION: The AN/VLQ-9 "SHORTSTOP" is a mobile, electronic countermeasure system designed to protect personnel and high value targets from the most predominant of indirect fire threats without operator intervention. The AN/VLQ-9 (LPU) is a vehicular version of SHORTSTOP and is mounted on either a HMMWV (M-998, M-1037, or M-1097) or a tracked M113A2 carrier. The AN/VLQ-9 was developed and built in response to Operation Desert Storm Quick Reaction Capability (QRC). Based on USAIS requirements "SHORTSTOP" will be militarized and reduced in size and weight for manpacked portability. Special features of the militarized, light weight SHORTSTOP will include Autonomous Operation, Contiguous Coverage, BIT/BITE and an Omni-Directional Antenna. Ten of the AN/VLQ-9 version and fourteen AN/VLQ-10 version, modified for a multiband OMNI-Directional Capability, are currently in contingency storage.

TRANSPORTATION CHARACTERISTICS / LIMITATIONS: Heavy 90 lbs. unit; Held in a contingency storage.

HISTORICAL BACKGROUND:

Nov 90 CINC CENTCOM QRC Statement of Need.
Feb 91 Limited Procurement Contract Award (LPU) for the AN/VLQ-9.
Aug 91 Limited Live Fire Test.
Aug 92 Full Live Fire Test.
May 93 Contract awarded for Risk Reduction Efforts, Multi-Band Upgrade AN/VLQ-10 and Omni-Directional coverage.

REQUIREMENTS DOCUMENT: Nov 90, CINC CENTCOM Mission Need Statement, Jun 94, ORD approved, U.S. Army Infantry School Fort Benning, Georgia.

TYPE CLASSIFICATION: TBD.

RELEASEABLE TO SECURITY ASSISTANCE CUSTOMERS: No

SYNOPSIS: SHORTSTOP IS A MOBILE. ELECTRONIC COUNTERMEASURE SYSTEM DESIGNED TO PROTECT PERSONNEL AND HIGH VALUE TARGETS FROM THE MOST PREDOMINANT OF INDIRECT FIRE THREATS WITHOUT OPERATOR INTERVENTION. THE AN/VLQ-9 IS THE SINGLE BAND SYSTEM AND THE AN/VLQ-10 IS THE MULTI-BAND SYSTEM.

PM, FIREFINDER

SHORTSTOP ELECTRONIC PROTECTION SYSTEM (SEPS)

PROJECT MANAGER: LTC Thomas M. Cole,
DSN 987-5618
COMM 732/427-5618

ACQUISITION CATEGORY: III
ACQUISITION PHASE: MS II Eng/Manufacturing Dev

PE & LINE: RDTE 64270/DL18
OPA VA8000

DESCRIPTION: The SHORTSTOP is an Electronic Protection System (SEPS) designed to counter artillery and mortar proximity fuzes. The SEPS will be an electronic counter-measures system composed of a core Receiver/Transmitter and sufficient additional components to allow it to be configured in three distinct versions: Manpack; Stand-alone; and Vehicular. The SEPS EMD will provide for increased capability with lower weight and size than the systems predecessor, the AN/VLQ-9 Countermeasures Set.

TRANSPORTATION CHARACTERISTICS / LIMITATIONS: The SHORTSTOP Manpack weight shall not exceed 25 lbs. The weight of vehicle mount or standalone configuration shall not exceed 50 lbs.

HISTORICAL BACKGROUND:

Jun 94 MS II Approval.
Jul 94 EMD Contract Award.

REQUIREMENTS DOCUMENT: June 94, Approved ORD, US Army Infantry School, Fort Benning, Georgia.

TYPE CLASSIFICATION: TBD.

RELEASEABLE TO SECURITY ASSISTANCE CUSTOMERS: No

Operational Concept

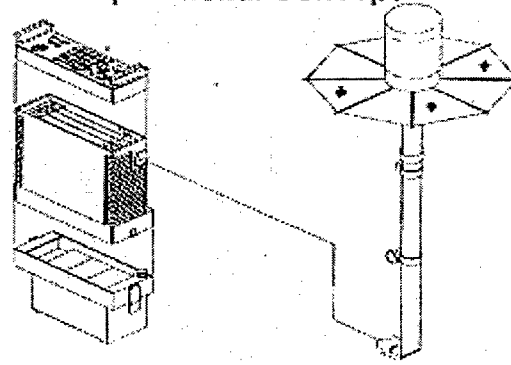

EVENT SCHEDULE	FISCAL YEAR		97		98		99		00		01		02	
	QTR		1	2	3	4	1	2	3	4	1	2	3	4
PPQT Contractor Test			2-3											
PPQT Government Test			3											
Limited User Test (LUT)			4											
Award Production Contract					1									
Production					1-----		-----3							
First Unit Equipped							2							

SYNOPSIS: SHORTSTOP IS A MOBILE, ELECTRONIC COUNTERMEASURE SYSTEM DESIGNED TO PROTECT PERSONNEL AND HIGH VALUE TARGETS FROM THE MOST PREDOMINANT OF INDIRECT FIRE THREATS WITHOUT OPERATOR INTERVENTION. THE AN/VLQ-9 IS THE SINGLE BAND SYSTEM AND THE AN/VLQ-10 IS THE MULTI-BAND SYSTEM.

PM, GPS

PM, GPS

GLOBAL POSITIONING SYSTEM (GPS)

PRODUCT MANAGER: LTC J. Lofgren,
DSN 992-6301
COMM 732/532-6301

ACQUISITION CATEGORY: IC
ACQUISITION PHASE: MS III Production/Deployment

PE & LINE #: 0604778A.D168 SSN: K47800

DESCRIPTION: The GPS is a space based radio positioning/navigation (POS/NAV) system that provides extremely accurate, three dimensional, common grid position, velocity and time of day information to users anywhere on or near the earth. The system consists of space, control, and user equipment segments. The USAF Space Command manages the operational satellites and ground control facilities. The user segment consists of those equipments that receive the satellite signals and compute position and time of day for the user. The GPS User Equipment (UE) family consists of different receivers meeting the needs that range from the foot soldier to high performance military aircraft. The basic UE capability is the determination and display of position and time data; most receivers do additional navigational calculations such as waypoint/target range and azimuth. Greater host vehicle dynamics and the need for interfaces to other navigation, communication or control systems may require enhanced capabilities. The USAF is the executive service. Army PM GPS provides personnel to man the Joint Program Office; coordinate Army user requirements; perform Army planning, programming and budgeting; and plan and implement Army logistics and deployment for Army UE.

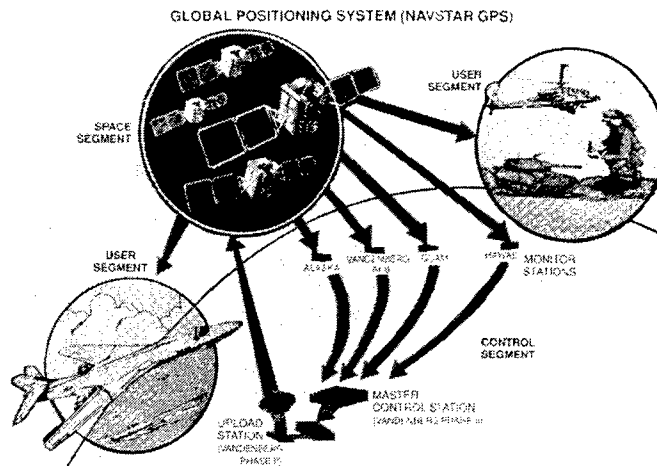

TRANSPORTATION CHARACTERISTICS / LIMITATIONS: PLGR < 3 Lbs (w/Prime Battery Installed); < 90 Cubic In.;
MAGR - 15 lbs, 2 LRUs. SAGR 3-1/2 lbs., 91 cubic inches. CUGR 6lbs 5.75 "Wx3.5" Hx12" D

HISTORICAL BACKGROUND:

- Jul 79 Full scale competitive contract awards to Rockwell/Collins and Magnavox.
- Dec 91 Restructure Army UE program to give priority to Ground Users; 1 & 2-Channel Receivers procurement projects cancelled.
- Jan 92 MS III DAB approved Full Rate Production of 5-Channel Air and Sea UE.
- Feb 92 USAF PEO approves Precision Lightweight GPS Receiver (PLGR) acquisition strategy; PLGR draft Letter Request for technical proposal and bid samples released.
- Dec 92 PEO Comm IPR for PLGR-MSIII Decision and TC Standard.
- Sep 96 PEO Letter IPR for CUGR.

REQUIREMENTS DOCUMENTS: NAVSTAR GPS Army UE ROC approved by HQDA 22 Mar 79; ASARC IIIA approved, baseline Revised ROC to include PLGR and MAGR approved 15 Apr 91. Draft ORD being staffed to include DAGR requirements.

TYPE CLASSIFICATION: MILSPEC Limited Production-Urgent/Limited Production-Test (LPU/LPT) approved Feb 87; SLGR Limited Production-Urgent approved Aug 90; PLGR Standard approved Jan 94; Standard approved for 1, 2 & 5 Channel Army UE Dec 91; MAGR LRP approved Jan 92. CUGR Standard approved Sep 96.

RELEASEABLE TO SECURITY ASSISTANCE CUSTOMERS: No

EVENT SCHEDULE	FISCAL YEAR QTR	97		98		99		00		01		02	
		1	2	3	4	1	2	3	4	1	2	3	4
PLGR Prod. Deliveries					3								
Option 4 (PLGR)		3											
Last option (MAGR)		3											
MAGR Follow-On Contract Award						1							
DAGR RFP							4						
DAGR Contract award								2					

SYNOPSIS: GPS PROVIDES EXTREMELY ACCURATE THREE DIMENSIONAL POSITION AND VELOCITY INFORMATION TO COMPATIBLY EQUIPPED USERS ANYWHERE ON OR NEAR THE EARTH.

PM, MEP

PM, MOBILE ELECTRIC POWER

DEPLOYABLE POWER GENERATION AND DISTRIBUTION SYSTEM (DPGDS)

PROJECT MANAGER:

FAX: DSN 656-7004 COMM 703/806-7004

E-Mail: PMMEP@EROLS.COM

ACQUISITION CATEGORY: III

ACQUISITION PHASE: I

PE & LINE #: OPA3 RJC9 TAC ELEC PWR

SSN: M56400

DESCRIPTION: TBD.

TRANSPORTATION CHARACTERISTICS / LIMITATIONS:

TBD.

HISTORICAL BACKGROUND:

PM-MEP has taken the initiative to join with the Air force to begin formal multi-service coordination in an effort to define service requirements and structure a joint acquisition program. The Air Force System Command (ASC-VX), the Air combat Command (ACC), the USA Training and Doctrine Command (TRADOC), the US Army Prime Power Battalion (249th Engr Bn) and PM-MEP are collaborating to modernize and replace the Air Forces' Bare Base (Harvest Eagle/Falcon) and the Army's Prime Power Battalion (249th Engr Bn). This initiative will acquire, using predominantly commercial components, new generator sets and power distribution systems, to replace the aging and difficult to maintain assets. The Deployable Power Generation and Distribution System (DPGDS) will select up to two contractors to demonstrate a systems approach solution to the USAF/USA needs. After down select, the successful offeror will provide test/evaluation samples to conduct both production qualification/first article tests and operational tests. The generator sets, after satisfactory completion of testing, will be established as a DoD MEP standard.

REQUIREMENTS DOCUMENT: Joint ORD.

TYPE CLASSIFICATION: TBD.

RELEASEABLE TO SECURITY ASSISTANCE CUSTOMERS: Yes/No

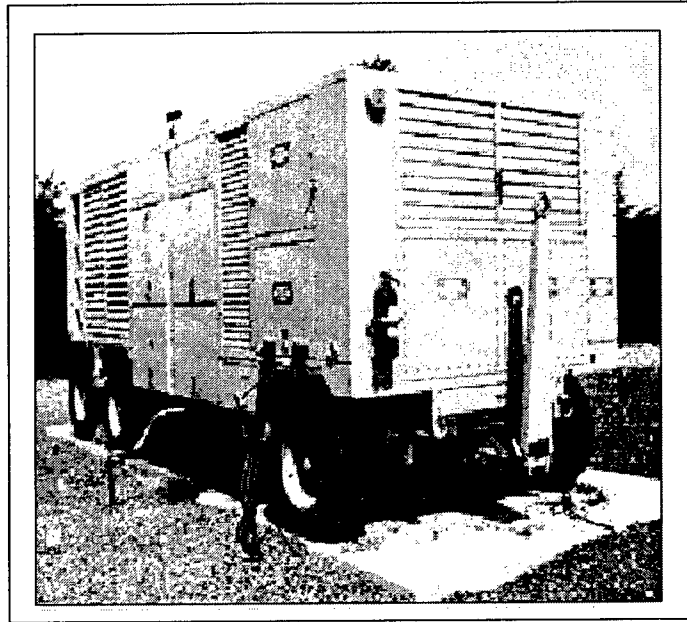

<u>EVENT SCHEDULE</u>	FISCAL YEAR	97	98	99	00	01	02
		1 2 3 4	1 2 3 4	1 2 3 4	1 2 3 4	1 2 3 4	1 2 3 4
TBD							

SYNOPSIS:

PM, MOBILE ELECTRIC POWER

MILITARY TACTICAL GENERATOR SET (2kW)

PROJECT MANAGER:

FAX: DSN 656-7004 COMM 703/806-7004

E-Mail: PMMEP@EROLS.COM

ACQUISITION CATEGORY: III

ACQUISITION PHASE: III

PE & LINE #: OPA3 RJC9 TAC ELEC PWR

SSN: M59300, M59400

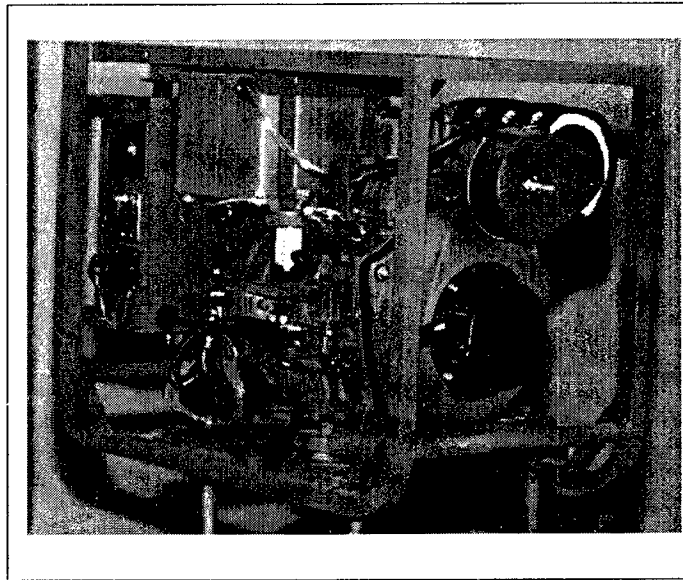

DESCRIPTION: The 2kW MTG is a NBC survivable, class 2C utility AC/DA power generator that operates on JP-8/Diesel fuel. It is transportable by marine/air/rail with a footprint not greater than current MIL-STD 1.5kW set and is 4 soldier portable. The set has solderless connections, emergency shutdown for low fuel/low oil, adjustable voltage and frequency, short duration overload capacity, hour meter and volt meter, is supportable by standard TMDE with PMCS in 20 minutes, and can be operated by soldiers in MOPP and Arctic gear.

TRANSPORTATION CHARACTERISTICS / LIMITATIONS:

29.5 x 16 x 21.8 (LxWxH), 158 lbs wet weight, 4 Soldier Portable.

HISTORICAL BACKGROUND:

In 1992, PM-MEP developed and staffed a new LT3kW Purchase Description (PD), but the effort was halted due to lack of Research and Development funding. In 1993, PM-MEP began an investigation of Canadian national Defense Ministry's effort to procure a diesel drive 2kW Military Tactical Generator (MTG) for the Canadian Armed Forces. This investigation revealed that the specification for the Canadian 2kW MTG was very similar to the U.S. specification. A Foreign Comparative Testing (FCT), Candidate Nomination Proposal (CNP) to test the Canadian 2kW generator set against the U.S. specification was developed and submitted to the Office of the Secretary of Defense (OSD). This proposal was accepted and funded by OSD with testing beginning in 1994. The favorable results of this testing resulted in the decision by PM-MEP to procure this generator system for the 2nd Generation DoD family LT3kW replacement program. To meet urgent Rapid Deployment/Contingency Force requirements, 650 sets were procured in early FY96 with delivery/fielding in late CY96. With technical data obtained through the FCT, a competitive procurement was developed to procure additional 2kW sets with deliveries beginning in 1997.

REQUIREMENTS DOCUMENT: ORD Approved Mar 95.

TYPE CLASSIFICATION: TC Generic Approved Jan 96.

RELEASEABLE TO SECURITY ASSISTANCE CUSTOMERS: Yes/No

EVENT SCHEDULE	FISCAL YEAR QTR	97	98	99	00	01	02
		1 2 3 4	1 2 3 4	1 2 3 4	1 2 3 4	1 2 3 4	1 2 3 4
LPU Fielded		1					
FUE			1				
Final Delivery							2

SYNOPSIS:

PM, MOBILE ELECTRIC POWER

TACTICAL QUIET GENERATOR SETS (3Kw)

PROJECT MANAGER:

FAX: DSN 656-7004 COMM 703/806-7004

E-Mail: PMMEP@EROLS.COM

ACQUISITION CATEGORY: III

ACQUISITION PHASE: III

PE & LINE #: OPA3 RJC9 TAC ELEC PWR
 SSN: M58100, M53600, M50600,
 M54800

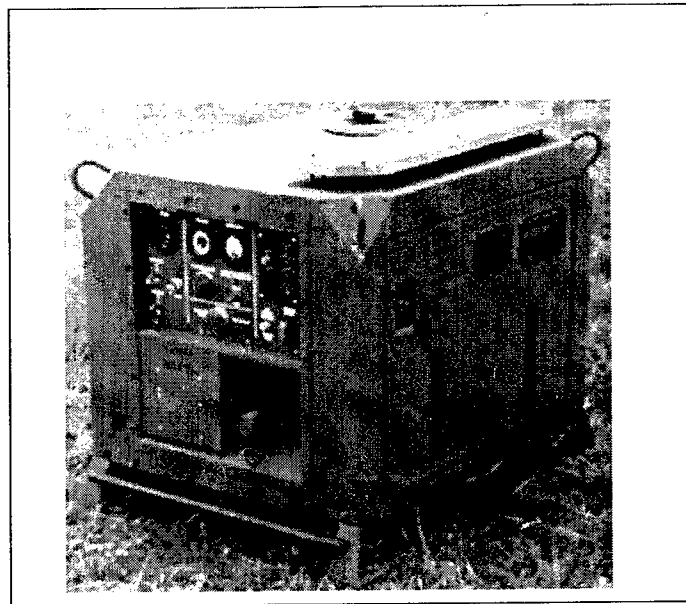

DESCRIPTION: These 3kW TQGs are being procured in both 60 and 400 Hz versions and are skid or trailer-mounted to meet tactical user requirements. Trailer mounted sets are Power Units (PU) - (one TQG per trailer), and Power Plants (PP) - (two TQGs per trailer).

TRANSPORTATION CHARACTERISTICS / LIMITATIONS:

TBD.

HISTORICAL BACKGROUND:

The current, aging fleet of MIL-STD gasoline engine driven and diesel engine driven 3kW generator sets is rapidly becoming logistically unsupportable and therefore a force readiness issue. There is an urgent operational requirements to replace these generator sets with a modernized, Tactical Quiet Generator (TQG) possessing the same desirable characteristics as other sets in the TQG family. With the march 1995 termination of the 1989 contract due to repeated First Article Test (FAT) failures, a restart 3kW TQG program was immediately initiated. The program acquisition strategy calls for multiple contractors to develop prototype generator sets during Phase I Development. A downselect will identify the contractor capable of providing the best value 3kW TQG to proceed into Phase II Development. A Low Rate Initial Production (LRIP) option will allow earlier fielding to Rapid Deployment/Contingency units. Production will begin in FY99. PM-MEP is committed to accelerating this program wherever possible to provide tactical forces the best 3kW TQG possible to meet their urgent operational requirements.

REQUIREMENTS DOCUMENT: Required Operational Capability (ROC) was revised in Jun 95.

TYPE CLASSIFICATION: TBD.

RELEASEABLE TO SECURITY ASSISTANCE CUSTOMERS: Yes/No

<u>EVENT SCHEDULE</u>	<u>FISCAL YEAR</u>		97		98		99		00		01		02	
			1	2	3	4	1	2	3	4	1	2	3	4
	<u>QTR</u>													
Competitive Shoot Off	1	3												
Award P2A & LRIP			1											
PQT LRIP Delivery				4										
LRIP FUE					1									
Award P3 Production					2									
1st Production delivery						1								
Final Delivery													2	

SYNOPSIS:

PM, MOBILE ELECTRIC POWER

TACTICAL QUIET GENERATOR SETS (5-60Kw)

PROJECT MANAGER:

FAX: DSN 656-7004 COMM 703/806-7004

E-Mail: PMMEP@EROLS.COM

ACQUISITION CATEGORY: III

ACQUISITION PHASE: III

PE & LINE #: OPA3 RJC9 TAC ELEC PWR

SSN: M50000, M50100, M50900, M51000,
M51100, M51800, M51900, M52000,
M52300, M52600, M52900, M53100,
M53200, M53400, M53500, M54100,
M54300, M54900, M56500, M57000,
M59500, M66200, R59000, R59100, R62700

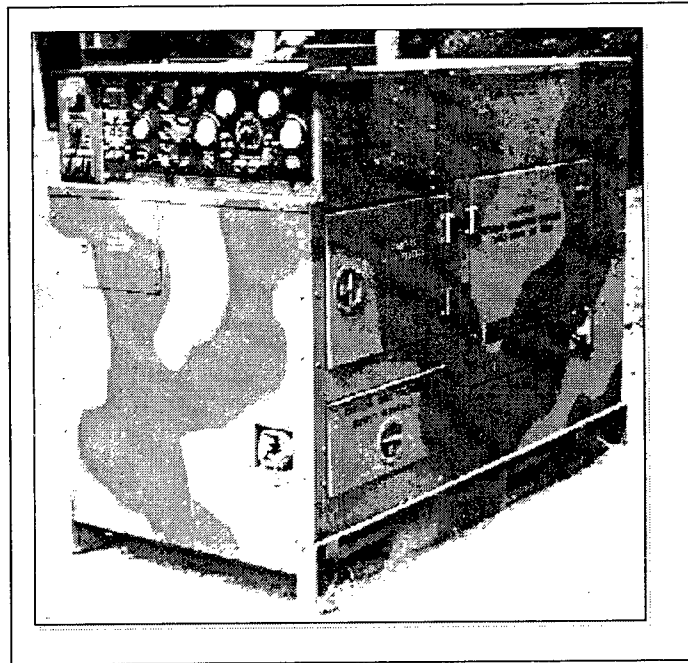

DESCRIPTION: The TQG design and construction philosophy was geared to the needs of a futuristic, modern, mobile DoD Total Force. These TQGs are being procured in 5kW, 10kW, 15kW, 30kW and 60kW sizes in both 60 and 400 Hz versions and are skid or trailer-mounted to meet tactical user requirements. Trailer mounted sets are Power Units (PU) and Power Plants (PP).

TRANSPORTATION CHARACTERISTICS / LIMITATIONS:

5kW - 50x31x36 (LxWxH), 911 lbs.
10kW - 61x31x36 (LxWxH), 1220 lbs.
15kW - 69x35x54 (LxWxH), 2238 lbs.
30kW - 79x35x54 (LxWxH), 3015 lbs.
60kW - 86x35x58 (LxWxH), 4153 lbs.

HISTORICAL BACKGROUND:

Approval for the implementation of an Army In-Process-Review (IPR) was granted in February 1988. The IPR authorities approved the initiation of a 5kW through 60kW program. Solicitations were released for full and open competition, which resulted in contract awards to Libby Corp in August, 1988. The 5kW through 60kW TQG sets were initially fielded in December 1993.

REQUIREMENTS DOCUMENT: Commercial Generator Set and Assemblages ROC (CGSA), approved Feb 88.

TYPE CLASSIFICATION: Standard.

RELEASEABLE TO SECURITY ASSISTANCE CUSTOMERS: Yes/No

<u>EVENT SCHEDULE</u>	<u>FISCAL YEAR</u> QTR	97		98		99		00		01		02	
		1	2	3	4	1	2	3	4	1	2	3	4
5 - 60kW:													
First Delivery			2										
Final Delivery								4					
5, 10, 15kW Rebuy:													
Award			3										
First Delivery				3									
30/60kW Re-Engine:													
FAT				3									
First Delivery								4					
FUE								4					

SYNOPSIS:

PM, MOBILE ELECTRIC POWER

UTILITY GENERATOR SETS (100-200kW)

PROJECT MANAGER:

FAX: DSN 656-7004 COMM 703/806-7004

E-Mail: PMMEP@EROLS.COM

ACQUISITION CATEGORY: III

ACQUISITION PHASE: I

PE & LINE #: OPA3 RJC9 TAC ELEC PWR
SSN: M50400, M54400

DESCRIPTION: TBD

TRANSPORTATION CHARACTERISTICS / LIMITATIONS:

TBD

HISTORICAL BACKGROUND:

The current 100-200kW sets that are in the field must be upgraded to a newer Tactical Quiet Generator Family 100-200kW generator. This will allow for easier maintainability, lower operational costs, and a more prepared and effective battlefield, which will operate using diesel fuel only.

REQUIREMENTS DOCUMENT: Commercial Generator Set and Assemblages (CGSA), approved Feb 88. (100kW only).

TYPE CLASSIFICATION: TBD.

RELEASEABLE TO SECURITY ASSISTANCE CUSTOMERS: Yes/No

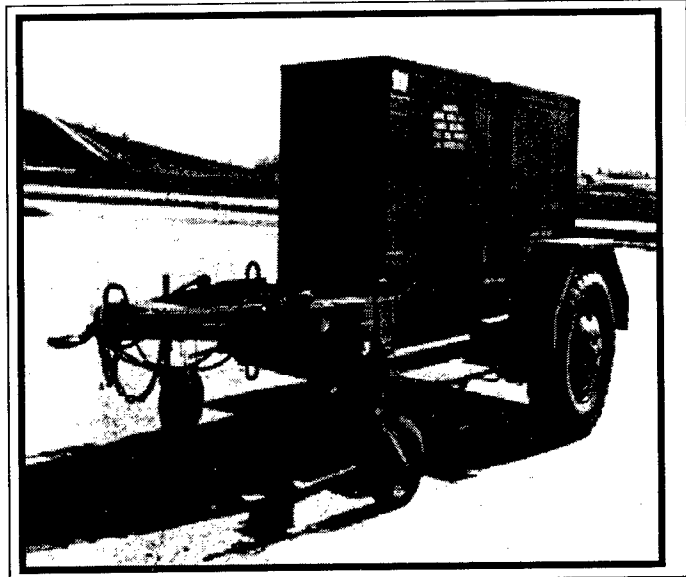

<u>EVENT SCHEDULE</u>	<u>FISCAL YEAR</u>		97	98	99	00	01	02
	<u>QTR</u>		1 2 3 4	1 2 3 4	1 2 3 4	1 2 3 4	1 2 3 4	1 2 3 4
TBD								

SYNOPSIS:

APPENDICES

ALPHABETICAL INDEX BY ACRONYM

ACRONYM	PAGE	ACRONYM	PAGE
AC	19-13	DSSMP	30-2
ADA BDE TOC	1-5	DTSS	11-1
ADLP	18-1	DTSS/QRMP	11-2
ADSI	1-6	DVE	14-8
AFATDS	5-1	EFF	32-6
AHFWS	22-11	EPLRS	9-2
AHP	25-4	EQUATE	19-12
AIN	27-1	ET	22-21
AIT	18-16	FAADC2	1-10
AKMS	10-7	FED	5-3, 19-16
ALERT	25-10	FHMUX	9-5
AMDPCS	1-3	FIREFINDER	32-1
AMDWS	1-4	FOTS	21-21
ANDVT	21-16	FSAC	5-2
ANVIS	14-1	FTSAT	7-3
ANNEX C	1-7	GBCS-H	16-3
ANVIS/HUD	14-2	GBCS-L	16-4
AQF	16-1	GBS	7-4
ARL	16-2	GNDCP	7-1
ASAS	6-2	GOLDWING	22-1
ASSI	25-9	GPS	33-1
ATCC	19-11	GR/CS	16-5
ATCCSS	19-6	HG	22-15
ATM	10-8	HQ II	19-1
BCIS	12-1	HT/MT	31-2
BCS	19-9	HTI/SGF	14-9
BC2	23-5	HUNTER	25-12
BSTRS	28-1	IAL	22-2
C2V MMS	3-1	ICS3	18-10
CHALS-X	16-7	IFSAS	5-4
CHIMS	6-3	IGRV	22-24
CHS	3-2	ILOGS	18-8
CID	12-2	IMETS	6-4
CIDS	12-3	IPS	26-10
CINC TMD	1-9	I-REMBASS	22-27
CMES	16-6	ISYSCON	10-11
CNCMS	4-1	JCALs	18-3
CSCCE	31-8	JCMT	6-5
CSCE	10-6	JRISS	18-4
CSSCS	8-1	JRSC	31-6
CTASC-I	19-14	JSTARS	13-2
CTASC-II	18-17, 19-15	JTIDS	9-3
CUITN	30-1	JTT	13-1
DAMMS-R	18-9	LDF	21-17
DAMP	10-10	LFED	5-5
DAS-3 (D/C)	19-10	LHGXA	7-5
DBC	26-7	LLDR	14-10
DBS	26-9	LMRDFS	22-7
DCSS	26-8	LMST	7-6
DECS	31-9	LRAS3	14-12
DFCS	31-4	LRSU-BRS	21-13
DGPS	23-7	LST8000 (V) T	7-7
DMS-A	18-2	LTACFIRE	19-18
DOSS/DASA	31-5	LT LCS	28-2
DPGDS	34-1	LUCKY MAIN	1-12

ALPHABETICAL INDEX BY ACRONYM

ACRONYM	PAGE	ACRONYM	PAGE
LVRS	14-11	TCP-NDI	19-13
MAST	21-1	TEAMMATE	22-16
MCS	3-4, 19-13	TESAR	14-14
MDS	22-12	TF/DIV XXI TOC	1-13
MELIOS	25-18	TFOCA	26-6
MINIFIX	22-6	TLOS	14-7
MMS	22-13, 14	TRACKWOLF	22-20
MNVD	14-6	TRAFFICJAM	22-10
MSE	10-12	TRAILBLAZER	22-19
MTMP	30-3	TROPO	21-10
NES	10-13	TSS	26-12
NMT	10-14	TTA	19-20
OSCAR	30-4	TWS	14-3
PERMS	18-18	ULLS	18-14
PEWS	22-18	UM	31-12
PLRS	9-1	VIS	21-23
QEAM	21-2	WIN-TT	10-17
QUICKFIX	22-26		
RBATSON	31-10		
RFPI-C2	23-9		
RN	21-22		
RSCCE	31-11		
SAAS	18-11		
SAMS	18-12		
SAMT	31-7		
SARSS	18-13		
SBA	18-5		
SCAMP BLOCK I	7-9		
SCAMP BLOCK II	7-10		
SCCE	31-3		
SCP	29-1		
SCTRS	26-3		
SENTINEL	15-1		
SEPS	32-9		
SHORTSTOP	32-8		
SICPS	3-5		
SIDPERS-3	18-6		
SINGARS	9-4		
SMART-T	7-8		
SMCT	31-1		
SMU	10-16		
SNS	14-5		
SOFTACS	7-11		
SPITFIRE	7-2		
STACCS	8-2		
STACOMP	18-19		
STARLOS	14-13		
STAR-T	7-12		
TACCS	19-19		
TACFIRE	19-8		
TACFIX	22-17		
TACJAM-A	16-8		
TACMIS	18-15		
TC-AIMS-II	18-7		

SYSTEM/EQUIPMENT INDEX BY NOMENCLATURE

NOMENCLATURE	PAGE	NOMENCLATURE	PAGE
AB-1309/TRC	21-1	AN/PVS-6	25-18
AB-1386/U	21-2	AN/PVS-7D	14-4
AN/ARC-164 (V)	19-1	AN/PVS-10	14-5
AN/ARC-220 (V)	19-2	AN/PVS-14	14-6
AN/ASC-15B	19-3	AN/TLQ-17A (V)	22-10
AN/ASN-128B	19-4	AN/TLQ-33	22-11
AN/AVS-6	14-1	AN/TMQ-31	22-12
AN/AVS-7	14-2	AN/TMQ-38	22-13
AN/AYD-1	19-5	AN/TMQ-40	6-4
AN/FGQ-13	31-1	AN/TMQ-41	22-14
AN/FRC-181 (V) 1	7-1	AN/TMQ-42	22-15
AN/FSC-78	31-2	AN/TPQ-36	32-2
AN/FSC-79	31-2	AN/TPQ-37	32-4
AN/FSC-91	31-3	AN/TPQ-37 (V) ATG	32-5
AN/FSC-92	19-6	AN/TPQ-37 (V) EFF	32-6
AN/FSC-96	31-4	AN/TRC-138A	10-1
AN/FSQ-142	31-5	AN/TRC-138B	10-1
AN/FYQ-110	31-5	AN/TRC-138C	10-1
AN/GRC-193	21-3	AN/TRC-170 (V) 2	21-10
AN/GRC-213	21-4	AN/TRC-170 (V) 3	21-10
AN/GRC-222	21-5	AN/TRC-173 ()	10-2
AN/GRC-240	19-7	AN/TRC-174 ()	10-3
AN/GRQ-27	22-1	AN/TRC-175 ()	10-4
AN/GRQ-27 (V) 2	22-1	AN/TRC-194 (V) 1, (V) 2	7-1
AN/GSC-40	26-2	AN/TRQ-32A (V) 2	22-16
AN/GSC-49 (V) 1, 2, 3	31-6	AN/TRQ-37	22-17
AN/GSC-51	31-4	AN/TRS-2 (V)	22-18
AN/GSC-52 (V)	31-7	AN/TSC-85B	21-11
AN/GSG-10	19-8	AN/TSC-93B	21-11
AN/GSR-42	26-3	AN/TSC-94A	21-12
AN/GYK-29	19-9	AN/TSC-100A	21-12
AN/MLQ-38	16-3	AN/TSC-128	21-13
AN/MLQ-39	16-4	AN/TSC-156 (V) 1	7-11
AN/MSQ-64	26-4	AN/TSC-156 (V) 3	7-12
AN/MYQ-4A	19-10	AN/TSQ-73	1-1
AN/PAQ-4C	22-2	AN/TSQ-129	9-1
AN/PAS-13	14-3	AN/TSQ-138	22-19
AN/PEQ-2A	22-3	AN/TSQ-152	22-20
AN/PLQ-8	14-7	AN/TSQ-172	31-8
AN/PPS-5B	22-4	AN/TSQ-199	22-21
AN/PPX-3	22-5	AN/TSW-7A	19-11
AN/PRC-104	21-6	AN/TTC-39	10-5
AN/PRC-126	21-7	AN/TTC-39A	10-5
AN/PRC-127	21-8	AN/TTC-39D	10-5
AN/PRD-11	22-6	AN/TTC-41 (V)	21-14
AN/PRD-12	22-7	AN/TVS-5	22-22
AN/PSC-3	21-9	AN/TYQ-30 (V) 1	10-6
AN/PSC-5	7-2	AN/TYQ-30 (V) 2	10-6
AN/PVH - (1 & 2)	14-11	AN/TYQ-31	10-6
AN/PVS-4	22-8	AN/TYQ-48	11-1
AN/PVS-5A, 5B, 5C	22-9	AN/TYQ-67 (V) 1	11-2

SYSTEM/EQUIPMENT INDEX BY NOMENCLATURE

NOMENCLATURE	PAGE	NOMENCLATURE	PAGE
AN/UGC-144	21-15		
AN/ULQ-19V	22-23		
AN/USC-28 (V)	26-5		
AN/USC-43 (V) 2	21-16		
AN/USC-60	7-3		
AN/USD-9A	22-24		
AN/USD-9C	16-5		
AN/USM-410	19-12		
AN/UXC-7	21-17		
AN/UYQ-43 (V) 1	19-13		
AN/UYQ-43 (V) 2	19-13		
AN/VAS-5	14-8		
AN/VIC-3 (V)	21-23		
AN/VRC-100 (V)	19-2		
AN/VSC-7	21-9		
AN/VVS-2	22-25		
CA-67A/U	19-20		
CX-13295/G	26-6		
EH-60A	22-26		
MK-2488/G	21-18		
OG-174/VRC	21-19		
ON-422	10-15		
SB-3614 (V) A/TT	21-20		
TD-1456/VRC	9-5		

ALPHABETICAL INDEX BY SYSTEM/EQUIPMENT NAME

SYSTEM/EQUIPMENT	PAGE
ADVANCED CONCEPTS TECHNOLOGIES II SATELLITE MOVEMENT TRACKING SYS	23-1
ADVANCED ELECTRONIC WARFARE SENSORS	25-1
ADV NARROWBAND DIGITAL VOICE TERMINAL (ANDVT) TACTICAL TERMINAL	21-16
ADVANCED EOIR COUNTERMEASURES	25-2
ADVANCED FIELD ARTILLERY TACTICAL DATA SYSTEM (AFATDS)	5-1
ADVANCED FOCAL PLANE ARRAY	25-3
ADVANCED HELICOPTER PILOTAGE (AHP) TD	25-4
ADVANCED MINE DETECTION SENSORS	25-5
ADVANCED OPTICS AND DISPLAY APPLICATIONS	25-6
ADVANCED QUICKFIX (AQF)	16-1
ADVANCED RF COUNTERMEASURES	25-7
ADVANCED SIGNATURE MANAGEMENT AND DECEPTION	25-8
AERIAL SCOUT SENSORS INTEGRATION (ASSI)	25-9
AIR AND MISSILE DEFENSE COMMAND/FORCE PROJECTION TOC	1-2
AIR AND MISSILE DEFENSE PLANNING & CONTROL SYSTEM	1-3
AIR AND MISSILE DEFENSE WORKSTATION	1-4
AIR DEFENSE ARTILLERY BRIGADE TACTICAL OPERATIONS CENTER	1-5
AIR DEFENSE SYSTEMS INTEGRATOR (ADSI)	1-6
AIR/LAND ENHANCED RECONNAISSANCE & TARGETING (ALERT) ATD	25-10
AIR TRAFFIC CONTROL CENTRAL (ATCC) AN/TSW-7A	19-11
AIR TRAFFIC CONTROL COMMUNICATIONS SWITCHING SYSTEM (ATCCSS)AN/FSC-92	19-6
AIRBORNE RECONNAISSANCE LOW (ARL)	16-2
AIRBORNE RELAY	26-1
ALL SOURCE ANALYSIS SYSTEM (ASAS)	6-2
AMPLIFIER POWER SUPPLY: OG-174/VRC	21-19
ANALYST CONSOLE (AC) MANEUVER CONTROL SYSTEM (MCS)	19-13
ANNEX C EXTENDED AIR DEFENSE COMMON INTEROPERABILITY PROGRAM	1-7
APPLIQUE PROGRAM	2-1
ARMY ATR EVALUATION	25-11
ARMY DISTANCE LEARNING PROGRAM	18-1
ARMY HIGH FREQUENCY ELECTRONIC WARFARE SYSTEM (AHFEWS), AN/TLQ-33	22-11
ARMY INTEROPERABILITY NETWORK (AIN)	27-1
ARMY KEY MANAGEMENT SYSTEM (AKMS)	10-7
ARMY TACTICAL OPERATIONS CENTERS (TOC)	1-8
ASYNCHRONOUS TRANSFER MODE (ATM)	10-8
ATG MOBILITY IMPROVEMENT PROGRAM, AN/TPQ-37V	32-5
AUTOMATED IDENTIFICATION TECHNOLOGY (AIT)	18-16
AVIATION NIGHT VISION IMAGING SYSTEM (ANVIS), AN/AVS-6	14-1
AVIATION NIGHT VISION IMAGING SYSTEM/HEADS UP DISPLAY (ANVIS/HUD)	14-2
BASE SUPPORT TRUNKED RADIO SYSTEM (BSTRS)	28-1
BATTERY COMPUTER SYSTEM (BCS): AN/GYK-29	19-9
BATTLE COMMANDERS WORKSTATION - SPEECH RECOGNITION TECHNOLOGY	23-3
BATTLEFIELD COMBAT IDENTIFICATION SYSTEM (BCIS)	12-1
BATTLESPACE C2 DECISION AIDS	23-4
BATTLESPACE COMMAND AND CONTROL (BC2)	23-5
BATTLESPACE COMMANDER'S WORK STATION	23-6
CECOM/C2SID SUPPORT TO SSCOM, PM, SOLDIER	23-2
CENTRAL OFFICE, TELEPHONE, AUTOMATIC, AN/TTC-41V	21-14
CI/HUMINT MANAGEMENT SYSTEM (CHIMS)	6-3
COMMANDER IN CHIEF THEATER MISSILE DEFENSE (CINC TMD)	1-9
CIRCUIT SWITCH: AN/TTC-39, 39A, 39D	10-5
COMBAT IDENTIFICATION ADVANCED TECHNOLOGY DEMONSTRATION	12-2
COMBAT IDENTIFICATION DISMOUNTED SOLDIER	12-3
COMBAT SERVICE SUPPORT CONTROL SYSTEM (CSSCS)	8-1
COMBINED GROUND COMMAND POST TERMINAL, AN/GSC-40	26-2
COMMAND AND CONTROL VEHICLE (C2V) MISSION MODULE SYSTEM (MMS)	3-1
COMMON HARDWARE SYSTEMS (CHS)	3-2
COMMON MODULAR ELINT SYSTEM (CMES)	16-6
COMMON SOFTWARE SYSTEMS	3-3

ALPHABETICAL INDEX BY SYSTEM/EQUIPMENT NAME

SYSTEM/EQUIPMENT	PAGE
COMMON USER INSTALLATION TRANSPORT NETWORK (CUITN)	30-1
COMMUNICATION SYSTEM CONTROL ELEMENT (CSCE), AN/TYQ-30V1,V2, TYQ-31	10-6
COMMUNICATIONS CENTRAL - CONSOLE, AN/ASC-15B	19-3
COMMUNICATIONS HIGH ACCURACY LOCATION SUBSYSTEM EXPLOITABLE (CHALS-X)	16-7
COMMUNICATIONS TERMINAL: AN/UGC-144	21-15
COMPACT DIGITAL SWITCH (ON-422)	10-15
CONTINGENCY SATELLITE CONFIGURATION CONTROL ELEMENT (CSCCE), AN/TSQ-172	31-8
CORPS/THEATER ADP SERVICE CENTER I (CTASC-I)	19-14
CORPS/THEATER ADP SERVICE CENTER II (CTASC-II)	18-17,19-15
COUNTERNARCOTICS COMMAND & MANAGEMENT SYSTEM (CNCMS)	4-1
CREW SERVED WEAPON SIGHT, AN/TVS-5	22-22
DA MOVEMENTS MANAGEMENT SYSTEM-REDESIGN (DAMMS-R)	18-9
DECENTRALIZED AUTOMATED SERVICE SUPPORT SYSTEM (DIVISION/CORPS) (DAS-3)	19-10
DEFENSE MESSAGE SYSTEM-ARMY (DMS-A)	18-2
DEF SATCOM SYS ELEC COUNTER COUNTERMEASURES CONTROL SUBSYSTEM (DECS)	31-9
DEFENSE SATCOM SYS FREQ DIV MULTI ACCESS CONTROL SUBSYSTEM, Fsc-96, Gsc-51	31-4
DEPLOYABLE POWER GENERATION & DISTRIBUTION SYSTEM (DPGDS)	34-1
DIFFERENTIAL GPS (DGPS) TECHNOLOGY	23-7
DIGITAL BATTLEFIELD COMMUNICATIONS (DBC)	26-7
DIGITAL COMMUNICATIONS SATELLITE SUBSYSTEM (DCSS)	26-8
DIGITAL GROUP MULTIPLEXER ANTENNA MAST PROGRAM (DAMP)	10-10
DIGITAL SWITCHED SYSTEMS MODERNIZATION PROGRAM (DSSMP)	30-2
DIGITAL TOPOGRAPHIC SUPPORT SYS/QUICK RESPONSE MULTICOLOR PRINTER	11-2
DIGITAL TOPOGRAPHIC SUPPORT SYSTEM (DTSS)	11-1
DIRECT BROADCAST SATELLITE (DBS)	26-9
DOPPLER GPS, AN/ASN-128B	19-4
DOWN SIZED CSCE (D/S COMM SYSTEMS CONTROL ELEMENT)	10-9
DRIVER'S VIEWER, AN/VVS-2	22-25
DRIVER'S VISION ENHANCER (DVE), AN/VAS-5	14-8
DSCS OPER SPT SYS/DSCS AUTO SPECTRUM ANALYZER (DOSS/DASA) FYQ-110, FSQ-142	31-5
ELECTRONIC QUALITY ASSURANCE TEST EQUIPMENT (EQUATE), AN/USM-410	19-12
ENHANCED FIREFINDER BLOCK I, AN/TPQ-37V	32-6
ENHANCED POSITION LOCATION REPORTING SYSTEM (EPLRS)	9-2
ENHANCED TRACKWOLF (ET), AN/TSQ-199	22-21
FIBER OPTICS TRANSMISSION SYSTEM (FOTS)	21-21
FIRE SUPPORT ADA CONVERSION (FSAC)	5-2
FIREFINDER ARTILLERY LOCATING RADAR, AN/TPQ-37	32-4
FIREFINDER MORTAR LOCATING RADAR, AN/TPQ-36	32-2
FIREFINDER MORTAR LOCATING RADAR, ELECTRONICS UPGRADE, AN/TPQ-36	32-3
FIREFINDER BLOCK II	32-7
FIREFINDER SYSTEMS	32-1
FLYAWAY TRI-BAND SATELLITE TERMINAL (FTSAT)	7-3
FORWARD AREA AIR DEFENSE, COMMAND AND CONTROL (FAADC2)	1-10
FORWARD ENTRY DEVICE (FED)	5-3,19-16
FREQUENCY HOPPING MULTIPLEXER (FHMUX), TD-1456/VRC	9-5
GLOBAL BROADCAST SERVICE (GBS)	7-4
GLOBAL POSITIONING SYSTEM (GPS)	33-1
GOLDWING, AN/GRQ-27	22-1
GROUND BASED COMMON SENSOR HEAVY (GBCS-H), AN/MLQ-38	16-3
GROUND BASED COMMON SENSOR LIGHT (GBCS-L), AN/MLQ-39	16-4
GUARDRAIL/COMMON SENSOR (GR/CS), AN/USD-9C	16-5
HAVE QUICK II (HQ II), AN/ARC-164V	19-1
HAVE QUICK II (HQ II) GROUND RADIO, AN/GRC-240	19-7
HEAVY TERMINAL & MEDIUM TERMINAL (HT/MT) MODERNIZATION PROGRAM	31-2
HIGH FREQUENCY RADIO (AN/ARC 220 AND VRC 100)	19-2
HORIZONTAL TECHNOLOGY INTEGRATION SECOND GENERATION FLIR (HTI SGF)	14-9
HUNTER SENSOR SUITE ATD	25-12
HYDROGEN GENERATOR (HG) (AN/TMQ-42)	22-15

ALPHABETICAL INDEX BY SYSTEM/EQUIPMENT NAME

SYSTEM/EQUIPMENT	PAGE
III CORPS ARTILLERY ASSAULT COMMAND POST/MAIN COMMAND POST (MCP)	1-11
IMPROVED GUARDRAIL V (IGRV) (AN/USD-9A)	22-24
IMPROVED HIGH FREQUENCY RADIO SET: AN/GRC-213	21-4
IMPROVED HIGH FREQUENCY RADIO SET: AN/PRC-104	21-6
IMPROVED HIGH FREQUENCY RADIO SET: AN/GRC-193	21-3
IMPROVED-REMOTELY MONITORED BATTLEFIELD SENSOR SYSTEM (I-REMBASS)	22-27
INDIVIDUAL SERVED WEAPON SIGHT (AN/PVS-4)	22-8
INFRARED AIMING LIGHT (AN/PAQ-4C)	22-2
INFRARED ILLUMINATOR (AN/PEQ-2A)	22-3
INITIAL FIRE SUPPORT AUTOMATED SYSTEM (IFSAS)	5-4
INSTALLATION KIT: MK-2488/G	21-18
INTEGRATED COMBAT SERVICE SUPPORT SYSTEM (IC3S)	18-10
INTEGRATED COUNTERMEASURES	25-13
INTEGRATED LOGISTICS SYSTEMS (ILOGS)	18-8
INTEGRATED METEOROLOGICAL SYSTEM (IMETS) (AN/TMQ-40)	6-4
INTEGRATED PHOTONIC SUBSYSTEMS (IPS)	26-10
INTEGRATED SENSORS & TARGETING	25-15
INTEGRATED SENSOR MODELING AND SIMULATION	25-14
INTEGRATED SYSTEMS CONTROL (ISYSCON)	10-11
INTERFACE UNIT, AUTOMATIC DATA PROCESSING, CA-67A/U	19-20
INTERROGATOR SET: AN/PPX-3	22-5
JAM RESISTANT SECURE COMMUNICATIONS (JRSC) TERMINALS, AN/GSC-49 (V) 1, 2, 3	31-6
JOINT COLLECTION MANAGEMENT TOOLS (JCMT)	6-5
JOINT COMPUTER AIDED ACQUISITION AND LOGISTICS SUPPORT (JCALs)	18-3
JOINT RECRUITING INFORMATION SUPPORT SYSTEM (JRISS)	18-4
JOINT STARS GROUND STATION MODULE / COMMON GROUND STATION	13-2
JOINT TACTICAL INFORMATION DISTRIBUTION SYSTEM (JTIDS)	9-3
JOINT TACTICAL TERMINAL (JTT)	13-1
LARGE-SCALE TACTICAL DOCUMENT COPIER	19-17
LIGHT MULTIBAND SATELLITE TERMINAL (LMST)	7-6
LIGHTWEIGHT DIGITAL FACSIMILE (LDF) (AN/UXC-7)	21-17
LIGHTWEIGHT FORWARD ENTRY DEVICE (LFED)	5-5
LIGHTWEIGHT HIGH GAIN X-BAND ANTENNA (LHGXA)	7-5
LIGHTWEIGHT LASER DESIGNATOR RANGE FINDER (LLDR)	14-10
LIGHTWEIGHT MANTRANSPORTABLE RADIO DIRECTION FINDER SYSTEM (LMRDFS)	22-7
LIGHTWEIGHT SATELLITE TERMINAL UPGRADE (LST8000 (V)T)	7-7
LIGHTWEIGHT TACTICAL FIRE DIRECTION SYSTEM (LTACFIRE)	19-18
LIGHTWEIGHT VIDEO RECONNAISSANCE SYSTEM (LVRS)	14-11
LIGHTWEIGHT, AIRBORNE, MULTISPECTRAL, COUNTERMINE DETECTION SYSTEM	25-16
LONG RANGE SURVEILLANCE UNIT-BASE RADIO STATION (LRSU-BRS), AN/TSC-128	21-13
LONG RANGE ADVANCED SCOUT SURVEILLANCE (LRAS3)	14-12
LONG TERM LIFE CYCLE SUPPORT (LTLCS)	28-2
LOW COST EO/IR COUNTERMEASURES	25-17
MACOM TELEPHONE MODERNIZATION PROGRAM (MTMP)	30-3
MANEUVER CONTROL SYSTEM (MCS)	3-4
MANEUVER CONTROL SYSTEM (MCS): TCP/AC	19-13
MAST (AB-1309/TRC)	21-1
METEOROLOGICAL DATA SYSTEM (MDS): AN/TMQ-31	22-12
METEOROLOGICAL MEASURING SET (MMS): AN/TMQ-38	22-13
METEOROLOGICAL MEASURING SET (MMS): AN/TMQ-41	22-14
MICRO EYESAFE SOLID STATE LASER SOURCES	25-19
MILITARY TACTICAL GENERATOR SET	34-2
MILSTAR GROUND COMMAND POST (GNDCP) TERMINALS, AN-FRC-181V1, TRC-194V1, 2	7-1
MINE HUNTER/KILLER	25-20
MINI EYESAFE LASER INFRARED OBSERVATION SET (MELIOS) (AN/PVS-6)	25-18
MINI-FIX (AN/PRD-11)	22-6
MOBILE SUBSCRIBER EQUIPMENT (MSE)	10-12
MODIFICATION TO INTEGRATE PATRIOT, HAWK, KSA WEAPON SYSTEMS (AN/TSQ-73)	1-1
MONOCULAR NIGHT VISION DEVICE (MNVD) (AN/PVS-14)	14-6

ALPHABETICAL INDEX BY SYSTEM/EQUIPMENT NAME

SYSTEM/EQUIPMENT	PAGE
MULTI-FUNCTION STARING SENSOR SUITE ATD	25-21
MULTI-MISSION/COMMON MODULAR UAV SENSORS	25-22
MULTI-WAVELENGTH MULTI-FUNCTION LASER	25-24
MULTICHANNEL SUPER HIGH FREQUENCY SATCOM TERMINALS (AN/TSC-94A, 100A)	21-12
MULTISPECTRAL COUNTERMEASURES ATD	25-23
NAVIGATION TECHNOLOGY	23-8
NETWORK ENCRYPTION SYSTEMS (NES)	10-13
NETWORK MANAGEMENT TOOL (NMT)	10-14
NIGHT VISION GOGGLES (AN/PVS-7D)	14-4
NIGHT VISION GOGGLES (AN/PVS-5A, 5B, 5C)	22-9
NIGHT VISION INFRARED COMMON MODULES	22-28
OUTSIDE CABLE REHABILITATION PROGRAM (OSCAR)	30-4
PCS FOR THE SOLDIER	26-11
PERSONNEL ELECTRONIC RECORD MANAGEMENT SYSTEM (PERMS)	18-18
PERSONNEL LOCATOR SYSTEM (AN/AYD-1)	19-5
PLATOON EARLY WARNING SYSTEM (PEWS) (AN/TRS-2V)	22-18
POSITION LOCATION REPORTING SYSTEM (PLRS) (AN/TSQ-129)	9-1
PRECISION/RAPID COUNTER-MRL ACTD	17-1
QUICK ERECT ANTENNA MAST (QEAM) (AB-1386/U)	21-2
QUICKFIX (EH-60A)	22-26
RADAR SET: AN/PPS-5B	22-4
RADIO REPEATER SET: AN/TRC-138A, 138B, 138C	10-1
RADIO REPEATER SET: AN/TRC-174	10-3
RADIO SET: AN/GRC-222	21-5
RADIO SET: AN/PRC-126	21-7
RADIO SET: AN/PRC-127	21-8
RAPID BATTLEFIELD VISUALIZATION ACTD	17-2
RAPID FORCE PROJECTION INITIATIVE COMMAND & CONTROL (RFPI-C2)	23-9
RBATSON	31-10
REGENCY NET (RN) SYSTEM	21-22
REPLACEMENT SATELLITE CONFIGURATION CONTROL ELEMENT (RSCCE)	31-11
SAR TARGET RECOGNITION & LOCATION SYSTEM (STARLOS)	14-13
SATELLITE COMMUNICATIONS SET (AN/USC-28V)	26-5
SATELLITE CONFIGURATION CONTROL ELEMENT (SCCE) (AN/FSC-91)	31-3
SECURE MOBILE ANTI-JAM RELIABLE TACTICAL TERMINAL (SMART-T)	7-8
SENTINEL	15-1
SHORTSTOP	32-8
SHORTSTOP ELECTRONIC PROTECTION SYSTEM (SEPS)	32-9
SIGNAL JAMMER RACJAM (AN/ULQ-19V)	22-23
SINGLE CHANNEL ANTI-JAM MANPORTABLE TERMINAL (SCAMP)	7-9
SINGLE CHANNEL ANTI-JAM MANPORTABLE TERMINAL (SCAMP BLOCK II)	7-10
SINGLE CHANNEL GROUND AND AIRBORNE RADIO SYSTEM (SINGGARS)	9-4
SINGLE CHANNEL TRANSPONDER RECEIVING SET (SCTRS) (AN/GSR-42)	26-3
SINGLE CHANNEL UHF SATCOM TACTICAL TERMINALS (AN/PSC-3, VSC-7)	21-9
SINGLE CHANNEL UHF SPECIAL COMM SYSTEM-FORCE TERMINAL (AN/MSC-64)	26-4
SMALL COMPUTER PROGRAM (SCP)	29-1
SMART MULTI-CIRCUIT TERMINAL (SMCT) (AN/FGQ-13)	31-1
SNIPER NIGHT SIGHT (AN/PVS-10)	14-5
SOLDIER INDIVIDUAL POWER	23-10
SOLID STATE NEAR IR SENSORS	25-25
SPECIAL OPERATIONS FORCES TACTICAL ASSURED CONNECTIVITY SYSTEM	7-11
SPITFIRE ULTRA HIGH FREQUENCY DAMA TERMINAL, AN/PSC-5	7-2
STAMIS TACTICAL COMPUTERS (STACOMP)	18-19
STANDARD ARMY AMMUNITION SYSTEM (SAAS)	18-11
STANDARD ARMY MAINTENANCE SYSTEM (SAMS)	18-12
STANDARD ARMY RETAIL SUPPLY SYSTEM (SARSS)	18-13
STANDARD INSTALLATION/DIVISION PERSONNEL SYSTEM-3 (SIDPERS-3)	18-6
STANDARD INTEGRATED COMMAND POST SYSTEM (SICPS)	3-5

ALPHABETICAL INDEX BY SYSTEM/EQUIPMENT NAME

SYSTEM/EQUIPMENT	PAGE
STANDARD THEATER ARMY COMMAND AND CONTROL SYSTEM (STACCS)	8-2
STATE-OF-THE-ART MEDIUM TERMINAL (SAMT), AN/GSC-52 (V)	31-7
SUPER HIGH FREQUENCY TRI-BAND ADVANCED RANGE EXT TERM (STAR-T)	7-12
SUSTAINING BASE AUTOMATION	18-5
SWITCHBOARD: SB-3614 (V) A/TT	21-20
SWITCH MULTIPLEX UNIT (SMU)	10-16
TACFIRE (AN/GSG-10)	19-8
TACFIX (AN/TRQ-37)	22-17
TACJAM-A	16-8
TACTICAL ARMY COMBAT SERVICE SUPPORT COMPUTER SYSTEM (TACCS)	19-19
TACTICAL COMPUTER PROCESSOR (TCP) - NDI (AN/UYQ-43V1, V2)	19-13
TACTICAL ELECTRIC POWER	23-11
TACTICAL ENHANCED SYNTHETIC APERTURE RADAR (TESAR)	14-14
TACTICAL FIBER OPTIC CABLE ASSEMBLY (TFOCA) & ANCILLARY ITEMS (CX-13295/G)	26-6
TACTICAL MANAGEMENT INFORMATION SYSTEMS (TACMIS)	18-15
TACTICAL QUIET GENERATOR SETS (3KW)	34-3
TACTICAL QUIET GENERATOR SETS (5-60KW)	34-4
TACTICAL SATELLITE COMMUNICATIONS TERMINALS (AN/TSC-85B/93B)	21-11
TACTICAL TERMINAL ADAPTER (TTA)	19-20
TARGET ACQUISITION ATD	25-26
TARGET LOCATION & OBSERVATIONS SYSTEM (TLOS) (AN/PLQ-8)	14-7
TASK FORCE/DIVISION XXI TACTICAL OPERATIONS CENTERS (TF/DIV XXI TOC)	1-13
TEAMMATE (AN/TRQ-32A (V) 2)	22-16
THERMAL WEAPON SIGHT (TWS) (AN/PAS-13)	14-3
TRACKWOLF (AN/TSQ-152)	22-20
TRAFFICJAM (AN/TLQ-17A (V))	22-10
TRAILBLAZER (AN/TSQ-138)	22-19
TRANSPORTATION COORDINATOR - AUTOMATED INFO FOR MOVEMENT SYSTEMS II	18-7
TRI-BAND SATCOM SUBSYSTEM (TSS)	26-12
TROPOSCATTER RADIO TERMINAL (TROPO) (AN/TRC-170V2, V3)	21-10
UNIT LEVEL LOGISTICS SYSTEM (ULLS)	18-14
UNIVERSAL MODEM (UM)	31-12
US 3RD ARMY "LUCKY MAIN" TACTICAL OPERATIONS CENTER	1-12
UTILITY GENERATOR SETS (100-200KW)	34-5
VARIABLE MESSAGE FORMAT (VMF) & MIL-STD-188-220 STANDARDS	27-3
VARIABLE MSG FORMAT (VMF) TEST TOOL & MIL-STD-188-220 PROTOCOL TEST TOOL (PTT)	27-2
VEHICLE IN-LINE GENERATOR	23-12
VEHICULAR INTERCOM SYSTEM (VIS)	21-23
VEHICULAR MOUNTED MINE DETECTOR ATD	25-27
WARFIGHTER INFORMATION NETWORK (WIN) - TERRESTRIAL TRANSPORT (TT)	10-17