



**US Army Corps
of Engineers**

Waterways Experiment
Station

Technical Report ITL-97-7
December 1997

Earthquake Engineering Research Program

Accuracy of Response of Single-Degree-of-Freedom Systems to Ground Motion

by *Robert M. Ebeling, WES*
Russell A. Green, U.S. Defense Nuclear Facilities Safety Board
Samuel E. French, University of Tennessee at Martin

DTIC QUALITY INSPECTED 3

Approved For Public Release; Distribution Is Unlimited

19980210 084

DTIC QUALITY INSPECTED 3

Prepared for Headquarters, U.S. Army Corps of Engineers

The contents of this report are not to be used for advertising, publication, or promotional purposes. Citation of trade names does not constitute an official endorsement or approval of the use of such commercial products.

The findings of this report are not to be construed as an official Department of the Army position, unless so designated by other authorized documents.



PRINTED ON RECYCLED PAPER

Accuracy of Response of Single-Degree-of-Freedom Systems to Ground Motion

by Robert M. Ebeling

U.S. Army Corps of Engineers
Waterways Experiment Station
3909 Halls Ferry Road
Vicksburg, MS 39180-6199

Russell A. Green

U.S. Defense Nuclear Facilities Safety Board
625 Indiana Avenue, NW, Suite 700
Washington, DC 20004

Samuel E. French

University of Tennessee at Martin
Martin, TN 38237

Final report

Approved for public release; distribution is unlimited

DTIC QUALITY INSPECTED 3

Prepared for U.S. Army Corps of Engineers
Washington, DC 20314-1000

Under Work Unit 33011



**US Army Corps
of Engineers**
Waterways Experiment
Station

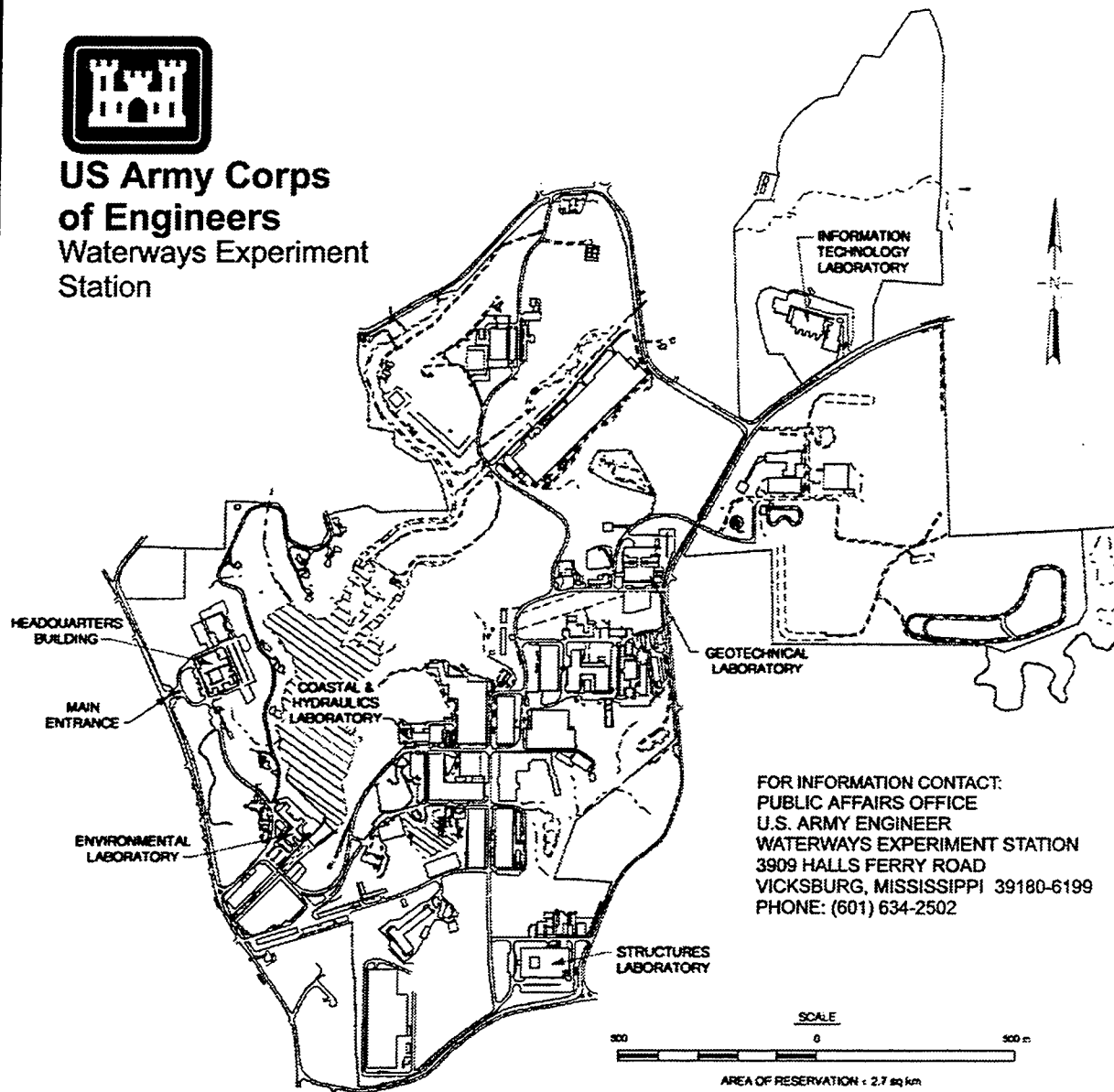

FOR INFORMATION CONTACT:
PUBLIC AFFAIRS OFFICE
U.S. ARMY ENGINEER
WATERWAYS EXPERIMENT STATION
3909 HALLS FERRY ROAD
VICKSBURG, MISSISSIPPI 39180-6199
PHONE: (601) 634-2502

Waterways Experiment Station Cataloging-in-Publication Data

Ebeling, Robert M., 1954-

Accuracy of response of single-degree-of-freedom systems to ground motion / by Robert M. Ebeling, Russell A. Green, Samuel E. French ; prepared for U.S. Army Corps of Engineers.

89 p. : ill. ; 28 cm. -- (Technical report ; ITL-97-7)

Includes bibliographic references.

1. Structural dynamics. 2. Time-domain analysis. 3. Hydraulic structures -- Testing. I. Green, Russell A. II. French, Samuel E., 1930- III. United States. Army. Corps of Engineers. IV. U.S. Army Engineer Waterways Experiment Station. V. Information Technology Laboratory (U.S. Army Engineer Waterways Experiment Station) VI. Title. VII. Series: Technical report (U.S. Army Engineer Waterways Experiment Station) ; ITL-97-7.

TA7 W34 no.ITL-97-7

Contents

Preface	vii
1—Accuracy of Response of Single-Degree-of-Freedom Systems to Ground Motion	1
1.0 Introduction	1
1.1 Six Methods Used to Compute Time Domain Responses	2
1.2 Direct Integration Methods	2
1.3 Difference Between Implicit and Explicit Numerical Methods	3
1.4 Questions of the Accuracy of All Six Step-by-Step Methods and the Stability of Numerical Integration and Numerical Differentiation Methods	4
1.5 Contents	4
2—Six Numerical Step-by-Step Procedures of Analysis of the Equation of Motion for an SDOF System	6
2.0 Introduction	6
2.1 Equation of Motion for SDOF System	7
2.2 Newmark β Method	11
2.3 Wilson θ Method	14
2.4 Central Difference Method	18
2.5 Duhamel's Integral	19
2.6 Piecewise Exact Method	22
2.7 4 th Order Runge-Kutta Method	24
3—Stability of Numerical Integration and Numerical Differentiation Methods	27
3.0 Introduction	27
3.1 Stability Criteria for Two Implicit Numerical Integration Methods	29
3.2 Stability Criteria for an Explicit Numerical Integration Method	30
3.3 Stability Criteria for a Numerical Differentiation Method	30
3.3.1 MDOF systems	30
3.4 Conclusions	31
4—Accuracy of Six Numerical Step-by-Step Procedures of Analysis of the Equation of Motion for SDOF Systems	32

4.0	Introduction	32
4.1	Error in Free Vibration Response of SDOF Systems	33
4.1.1	MDOF systems	34
4.1.2	Current guidance for assigning the time-step Δt to be used in earthquake engineering dynamic structural response analysis	36
4.2	Error in Response of SDOF Systems to Ground Motion	37
4.2.1	SDOF systems	37
4.2.2	Time-step Δt	38
4.2.3	Ground motion	38
4.2.4	Frequency of ground motion relative to frequency of SDOF systems	38
4.2.5	Time-histories of 432 step-by-step response analyses	40
4.2.6	Results from 12 of the 432 error studies	40
4.2.7	Summary of numerical results from all 432 error studies	47
4.2.8	Accuracy of numerical step-by-step procedures as a function of time-step Δt and frequency contained within the ground motion	52
4.3	Conclusions	62
5	—Results and Conclusions	64
5.0	Introduction	64
5.1	Stability Requirements for the Four Numerical Methods Used for Response Analysis	65
5.2	Accuracy of Response of SDOF Systems to Ground Motion	66
5.3	Baseline Correction of Ground Motion	69
5.4	Observations Made Regarding Response Analysis of Semidiscrete MDOF System Models	69
5.4.1	Stability requirements	70
5.4.2	Accuracy of response	71
5.4.3	Numerical damping of high-frequency response	72
5.4.4	Nonlinear analysis	73
	References	74
	Appendix A: Exact Solution to SDOF System Sine Wave Base Excitation	A1
	Appendix B: Fourier Series	B1
	SF 298	

List of Figures

Figure 1.	Dynamic response of two damped SDOF systems	8
-----------	---	---

Figure 2.	Forces acting on linear SDOF system at time t , external force $P(t)$ applied	9
Figure 3.	Inertial force acting opposite to the acceleration of mass m at time t , external force $P(t)$ applied	10
Figure 4.	Equivalent dynamic SDOF system problems	11
Figure 5.	Example of response for an undamped SDOF system in free vibration	28
Figure 6.	Errors in free vibration response of SDOF systems for α -methods, optimal collocation schemes, and Houbolt, Newark, Park, and Wilson methods	35
Figure 7.	Equivalent dynamic SDOF system problems	39
Figure 8.	Response spectra of two SDOF systems with 5 percent damping for three harmonic forcing functions	41
Figure 9.	SDOF system ($T_o = 0.25$ sec) response time-histories ($\Delta t = 0.01$ sec) computed using Wilson $\theta = 1.38$ for a sinusoidal forcing function of period $T_g = 0.05$ sec	42
Figure 10.	SDOF system ($T_o = 0.25$) response time-histories ($\Delta t = 0.01$ sec) computed using Wilson $\theta = 1.38$ for a sinusoidal forcing function of period $T_g = 0.25$ sec	43
Figure 11.	SDOF system ($T_o = 0.25$ sec) response time-histories ($\Delta t = 0.01$ sec) computed using Wilson $\theta = 1.38$ for a sinusoidal forcing function of period $T_g = 1.00$ sec	44
Figure 12.	Error in relative displacements computed using Wilson $\theta = 1.38$ for an SDOF system ($T_o = 0.25$ sec) with a sinusoidal forcing function of period $T_g = 0.05$ sec and $\Delta t = 0.01$ sec	46
Figure 13.	Percentile errors in maximum relative displacements (peak or valley value) for SDOF system of $T_o = 0.25$ sec	54
Figure 14.	Percentile errors in maximum relative velocity (peak or valley value) for SDOF system of $T_o = 0.25$ sec	55
Figure 15.	Percentile errors in maximum relative acceleration (peak or valley value) for SDOF system of $T_o = 0.25$ sec	56
Figure 16.	Percentile errors in maximum total acceleration (peak or valley value) for SDOF system of $T_o = 0.25$ sec	57
Figure 17.	Percentile errors in maximum relative displacements (peak or valley value) for SDOF system of $T_o = 0.5$ sec	58
Figure 18.	Percentile errors in maximum relative velocity (peak or valley value) for SDOF system of $T_o = 0.5$ sec	59

Figure 19.	Percentile errors in maximum relative acceleration (peak or valley value) for SDOF system of $T_o = 0.5$ sec	60
Figure 20.	Percentile errors in maximum total acceleration (peak or valley value) for SDOF system of $T_o = 0.5$ sec	61

List of Tables

Table 1.	Percentile Errors in Relative Displacement (Rel. D), Relative Velocity (Rel. V), Relative Acceleration (Rel. A), and Total Acceleration (Total A) for SDOF System of $T_o = 0.25$ sec and $\Delta t = 0.02$ sec	48
Table 2.	Percentile Errors in Relative Displacement (Rel. D), Relative Velocity (Rel. V), Relative Acceleration (Rel. A), and Total Acceleration (Total A) for SDOF System of $T_o = 0.5$ sec and $\Delta t = 0.02$ sec	49
Table 3.	Percentile Errors in Relative Displacement (Rel. D), Relative Velocity (Rel. V), Relative Acceleration (Rel. A), and Total Acceleration (Total A) for SDOF System of $T_o = 0.25$ sec and $\Delta t = 0.01$ sec	50
Table 4.	Percentile Errors in Relative Displacement (Rel. D), Relative Velocity (Rel. V), Relative Acceleration (Rel. A), and Total Acceleration (Total A) for SDOF System of $T_o = 0.5$ sec and $\Delta t = 0.01$ sec	51
Table 5.	Percentile Errors in Relative Displacement (Rel. D), Relative Velocity (Rel. V), Relative Acceleration (Rel. A) and Total Acceleration (Total A) for SDOF System of $T_o = 0.25$ sec and $\Delta t = 0.005$ sec	52
Table 6.	Percentile Errors in Relative Displacement (Rel. D), Relative Velocity (Rel. V), Relative Acceleration (Rel. A), and Total Acceleration (Total A) for SDOF System of $T_o = 0.5$ sec and $\Delta t = 0.005$ sec	53

Preface

The work described herein summarizes the results of an investigation of accuracy of response of Single-Degree-of-Freedom (SDOF) Systems to harmonic forced vibration using six linear multistep methods of analysis. Funding for the research and for preparation of this report was provided by the Earthquake Engineering (EQEN) Research Program sponsored by Headquarters, U.S. Army Corps of Engineers (HQUSACE). The research was performed under the EQEN Research Program Work Unit No. 33011, "Time Domain Solutions for Nonlinear Problems of Concrete Dams." Dr. Robert M. Ebeling, Information Technology Laboratory (ITL), U.S. Army Engineer Waterways Experiment Station (WES), and Mr. Tommy Bevins, Structures Laboratory (SL), WES, are the Principal Investigators for this work unit. Dr. Reed L. Mosher, SL, is the EQEN Laboratory Manager; Dr. Mary Ellen Hynes, Geotechnical Laboratory, WES, is the EQEN Laboratory Manager; and Dr. Robert Hall, SL, is the manager of the EQEN structural aspects. The HQUSACE area coordinator is Mr. Donald Dressler, while Mr. Lucian Guthrie is the Technical Monitor.

The work was performed at WES by Dr. Ebeling, by Mr. Russell A. Green of the U.S. Defense Nuclear Facilities Safety Board, and by Dr. Samuel French of the University of Tennessee at Martin. The report was written and prepared by Dr. Ebeling and Mr. Green under the direct supervision of Mr. H. Wayne Jones, Chief, Computer Aided Engineering Division, ITL, and Dr. N. Radhakrishnan, Director, ITL. Mr. John Hendricks, ITL, provided invaluable assistance in processing the results of the computer analyses and preparing the figures for the report.

At the time of publication of this report, Director of WES was Dr. Robert W. Whalin. Commander was COL Robin R. Cababa, EN.

The contents of this report are not to be used for advertising, publication, or promotional purposes. Citation of trade names does not constitute an official endorsement or approval of the use of such commercial products.

1 Accuracy of Response of Single-Degree-of-Freedom Systems to Ground Motion

1.0 Introduction

This report summarizes the results of an assessment of the accuracy of response of six numerical step-by-step procedures used in computational structural dynamics. The six algorithms used in this study are representative of the different types of numerical procedures used to compute the dynamic structural response to a time-dependent loading history. The time-dependent loading envisioned in this research is that of the *motion of the ground* below a discrete structural model and is expressed in terms of a ground acceleration time-history. The dynamic structural response for each structural model used in this study is characterized by the computed response time-histories of accelerations, velocities, and displacements.

All structural models used in this study are linear, single-degree-of-freedom (SDOF) systems. The natural (undamped) periods T_o of these SDOF systems are selected based on consideration of the important modal periods of hydraulic structures such as gravity dams, arch dams, gravity lock walls, U-frame locks, and intake towers. The forcing functions used in this study are single frequency harmonics. The use of a single frequency facilitated the evaluation of the accuracy of the computed responses solved for at regular time increments during ground motion.

The time increments Δt used in the analyses are 0.02, 0.01, and 0.005 seconds. These values are typical of the Δt used in discretizing earthquake acceleration time-histories (e.g., Hudson 1979) recorded in the field on strong motion accelerographs (shown in Figure 6.1.1 in Chopra 1995).

1.1 Six Methods Used to Compute Time Domain Responses

The six algorithms included in this study are the Newmark β method (with values of constants γ and β corresponding to the linear acceleration method), the Wilson θ method, the Central Difference Method, the 4th Order Runge-Kutta method, Duhamel's integral solved in a piecewise exact fashion, and the Piecewise Exact Method applied directly. All of these algorithms were used in their discretized forms (i.e., the loading and response histories were divided into a sequence of time intervals); thus, they are characterized as step-by-step procedures.

The six algorithms used can be categorized into two main groups, depending on their general approach to satisfying the differential equation of motion. The first group includes Duhamel's integral solved in a piecewise exact fashion and the Piecewise Exact Method applied directly. These two methods formulate exact solutions to the equation of motion for assumed forms of the time-dependent forcing functions (i.e., the loading is approximated by a series of straight lines between the time-steps). The second group includes Newmark β method, Wilson θ method, Central Difference Method, and 4th Order Runge-Kutta Method. These methods are referred to as *numerical methods* because they approximately satisfy the equation of motion during each time-step for the given loading. The Newmark β , Wilson θ , and 4th Order Runge-Kutta methods use *numerical integration* to step through the analysis of the time response problem, where the Central Difference Method uses *numerical differentiation*.

1.2 Direct Integration Methods

The linear acceleration method, Wilson's θ method, and the 4th Order Runge-Kutta method are examples of direct integration methods. The term "direct" means that prior to numerical integration, there is no transformation of the equations into a different form, such as is done in a frequency domain analysis. Integration methods are discrete in that the response values are solved for at regular increments in time during ground motion, which are separated by a time increment Δt .

Direct integration methods are based on two concepts. First, the equation of motion for the structural model is satisfied at discrete points in time (i.e., t , $t + \Delta t$, $t + 2\Delta t$, ...) during ground motion. Second, the forms of the variation in displacement, velocity, and acceleration responses within each time interval Δt are assumed.

1.3 Difference Between Implicit and Explicit Numerical Methods

Numerical methods such as direct integration methods are classified as either explicit or implicit integration methods. Chopra (1995), Subbaraj and Dokainish (1989a,b), Bathe (1982), and Bathe and Wilson (1976) distinguish between the two numerical methods as follows. The *explicit integration method* solves for the unknown values of displacement $x_{t+\Delta t}$, velocity $\dot{x}_{t+\Delta t}$, and acceleration $\ddot{x}_{t+\Delta t}$, at each new time $t + \Delta t$ using the equation of motion for the structural model at time t , with the unknown values for x_t , \dot{x}_t , and \ddot{x}_t at time t as the initial conditions. The *implicit integration method* solves for the unknown values of $x_{t+\Delta t}$, $\dot{x}_{t+\Delta t}$, and $\ddot{x}_{t+\Delta t}$ at each new time $t + \Delta t$ using the equation of motion at time $t + \Delta t$. For multiple-degree-of-freedom (MDOF) systems, implicit schemes require the solution of a set of *simultaneous* linear equations, whereas explicit schemes involve the solution of a set of linear equations, each of which involves a single unknown. Thus, the explicit integration method does not require a factorization of the coefficient matrix in the step-by-step solution of the equations of motion for the semidiscrete MDOF structural system model. The coefficient matrix is a combination of the stiffness, mass, and damping matrices of the MDOF model.

Along with others, Subbaraj and Dokainish (1989a,b) noted that implicit algorithms are most effective for structural dynamics problems (in which the response is controlled by a relatively small number of low-frequency modes), while explicit algorithms are very efficient for wave propagation problems (in which the contribution of intermediate- and high-frequency structural modes to the response is important). Accordingly, of the two types of numerical methods, implicit algorithms are more popular in earthquake engineering problems because of the larger time-step that may be used in the analysis.

However, implicit procedures involve considerable computational effort at each time-step compared with explicit methods for MDOF semidiscrete models since the coefficient matrices must be formulated, stored, and manipulated using matrix solution procedures. Therefore, in blast type problems where a small time-step is required to capture the structural response of large-scale models involving hundreds to thousands of degrees of freedom, implicit methods are computationally impractical, and explicit methods are the preferred type of algorithm.

Two explicit algorithms, the Central Difference Method and the 4th Order Runge-Kutta method, are included in this study. The original 1959 linear acceleration method version of the Newmark β family of numerical methods and Wilson's θ method are classified as implicit methods (Newark 1959). In general, implicit integration methods are frequently used by the structural dynamics/earthquake engineering community to solve for the response of semidiscrete MDOF structural models to earthquake excitation.

1.4 Questions of the Accuracy of All Six Step-by-Step Methods and the Stability of Numerical Integration and Numerical Differentiation Methods

The selection of the size of the time-step Δt to be used in the step-by-step calculation of the dynamic response of the SDOF (and of MDOF semidiscrete structural models) is restricted by stability and/or accuracy considerations for the six algorithms included in this study. The primary requirement of a numerical algorithm is that the computed response converge to the exact response as $\Delta t \rightarrow 0$ (Hughes 1987). However, the number of computations increases as the time-step Δt is made smaller in a dynamic analysis, an important issue for response analysis of semidiscrete MDOF structural system models.

In addition to accuracy considerations, stability requirements must also be considered during the selection of the time-step Δt to be used in a step-by-step response analysis either by the three numerical integration methods or by the numerical differentiation method. Stability criterion is expressed in terms of a *maximum allowable* size for the time-step, $\Delta t_{critical}$. The value for $\Delta t_{critical}$ differs among the four numerical algorithms.

No stability criteria (expressed in terms of a limiting time-step value) are needed for Duhamel's integral solved in a piecewise exact fashion and the Piecewise Exact Method applied directly. This is because these two methods formulate exact solutions to the equation of motion for assumed forms of the time-dependent forcing functions. There is only a question of the accuracy of the assumed form for the forcing function for the size time-step Δt being used in the analysis. In general, larger time-steps are likely to make the assumed form for the forcing function less valid.

1.5 Contents

Chapter 2 outlines the six algorithms used in this study to compute the response of an SDOF structural system. The stability criteria for the three numerical integration methods and for the numerical differentiation method are given in Chapter 3. These stability criteria are reviewed and their relevance to structural dynamics/earthquake engineering problems is discussed. Also, a numerical assessment of the largest time-step $\Delta t_{critical}$ that can be used in the response analysis is given. Conclusions are made concerning the stability criteria for the SDOF systems subjected to ground motion with Δt equal to 0.02, 0.01 and 0.005 seconds. A brief discussion and example application of stability criteria for semidiscrete MDOF structural system models are also included.

Using damped SDOF system models with natural periods assigned based on consideration of the modal periods of hydraulic structures providing significant

response contribution, an evaluation is made of the accuracy of the computed response values solved for at regular time increments during ground motion. All SDOF systems are assigned 5 percent damping. The results of this extensive series of numerical evaluations are summarized in Chapter 4. The results show the correlation of the accuracy of the six numerical step-by-step procedures, the harmonic characteristics of the ground motion, and the time-step Δt value (0.02, 0.01 or 0.005 seconds) used in the analysis. Also included is numerical assessment of the accuracy of the algorithms for computing the dynamic response of SDOF models in *free vibration*.

Chapter 5 summarizes the results of this study of the accuracy of six numerical step-by-step procedures used to compute the dynamic response of SDOF models with 5 percent damping. A brief discussion of the response analysis of semidiscrete MDOF structural system models to ground motion using numerical step-by-step procedures is also included.

Appendix A gives the exact solution to a SDOF system subjected to a sine wave base excitation.

Appendix B gives the Fourier series representation for a periodic function and the response of an SDOF system to a periodic force represented by a Fourier series. This algorithm is in the same category of algorithms as Duhamel's integral solved in a piecewise exact fashion and the Piecewise Exact Method applied directly in that it is an exact solution to an approximation of the actual loading.

2 Six Numerical Step-by-Step Procedures of Analysis of the Equation of Motion for an SDOF System

2.0 Introduction

This chapter outlines six numerical procedures for solving the dynamic response of SDOF models by solution of the dynamic equilibrium equation at closely spaced, discrete time intervals throughout the time of shaking. A base acceleration is used for the time-dependent loading. The dynamic response of each SDOF system used is characterized by the computed response time-histories of accelerations, velocities, and displacements. The next section begins with a summary of the equation of motion for an SDOF system model subjected to a base acceleration (e.g., ground motion).

The six algorithms included in this study are the Newmark β method (with values of constants γ and β corresponding to the linear acceleration method), the Wilson θ method, the Central Difference Method, the 4th Order Runge-Kutta method, Duhamel's integral solved in a piecewise exact fashion, and the Piecewise Exact Method applied directly. All of the algorithms were used in their discretized forms (i.e., the loading and response histories were divided into a sequence of time intervals); thus, they are characterized as step-by-step procedures.

These six algorithms can be categorized into two main groups, depending on their general approach to satisfying the differential equation of motion. The first group includes Duhamel's integral solved in a piecewise exact fashion and the Piecewise Exact Method applied directly. These two methods formulate exact solutions to the equation of motion for *assumed forms* of the time-dependent forcing functions (i.e., the loading is approximated by a series of straight lines between the time-steps). This group is easily identified by the fact that the total response consists of two parts: a transient (or free vibration) response contribution and the steady-state response (or particular solution to the specified form of the loading).

The second group of algorithms includes the Newmark β method, Wilson θ method, Central Difference Method, and 4th Order Runge-Kutta method. These methods are referred to as *numerical methods* because they approximately satisfy the equation of motion during each time-step for the *given* loading. The Newmark β , Wilson θ , and 4th Order Runge-Kutta methods use *numerical integration* to step through the analysis of the time response problem, where the Central Difference Method uses *numerical differentiation*.

2.1 Equation of Motion for SDOF System

Consider the case shown in Figure 1a of an idealized SDOF system subjected to a time-varying forcing function $P(t)$. At time equal to t , the SDOF system displaces a distance $x(t)$ from its at-rest position due to the applied force of $P(t)$, as shown in Figure 2. For a linear SDOF system acted on by an externally applied dynamic force $P(t)$, the equilibrium criterion (e.g., Chopra 1981 or Ebeling 1992) dictates that

$$f_i(t) + f_c(t) + f_k(t) = P(t) \quad (1)$$

where

$f_i(t)$ = inertial force

$f_c(t)$ = damping force

$f_k(t)$ = elastic resisting force

$P(t)$ = externally applied dynamic force

The inertia, damping, and elastic forces are related to the response quantities of the SDOF system through the following expressions:

$$f_i(t) = m\ddot{x}(t) , f_c(t) = c\dot{x}(t) , \text{ and } f_k(t) = kx(t) \quad (2)$$

where

m = mass of the SDOF system

$\ddot{x}(t)$ = relative acceleration of the mass

c = damping coefficient of the SDOF system

$\dot{x}(t)$ = relative velocity of the mass

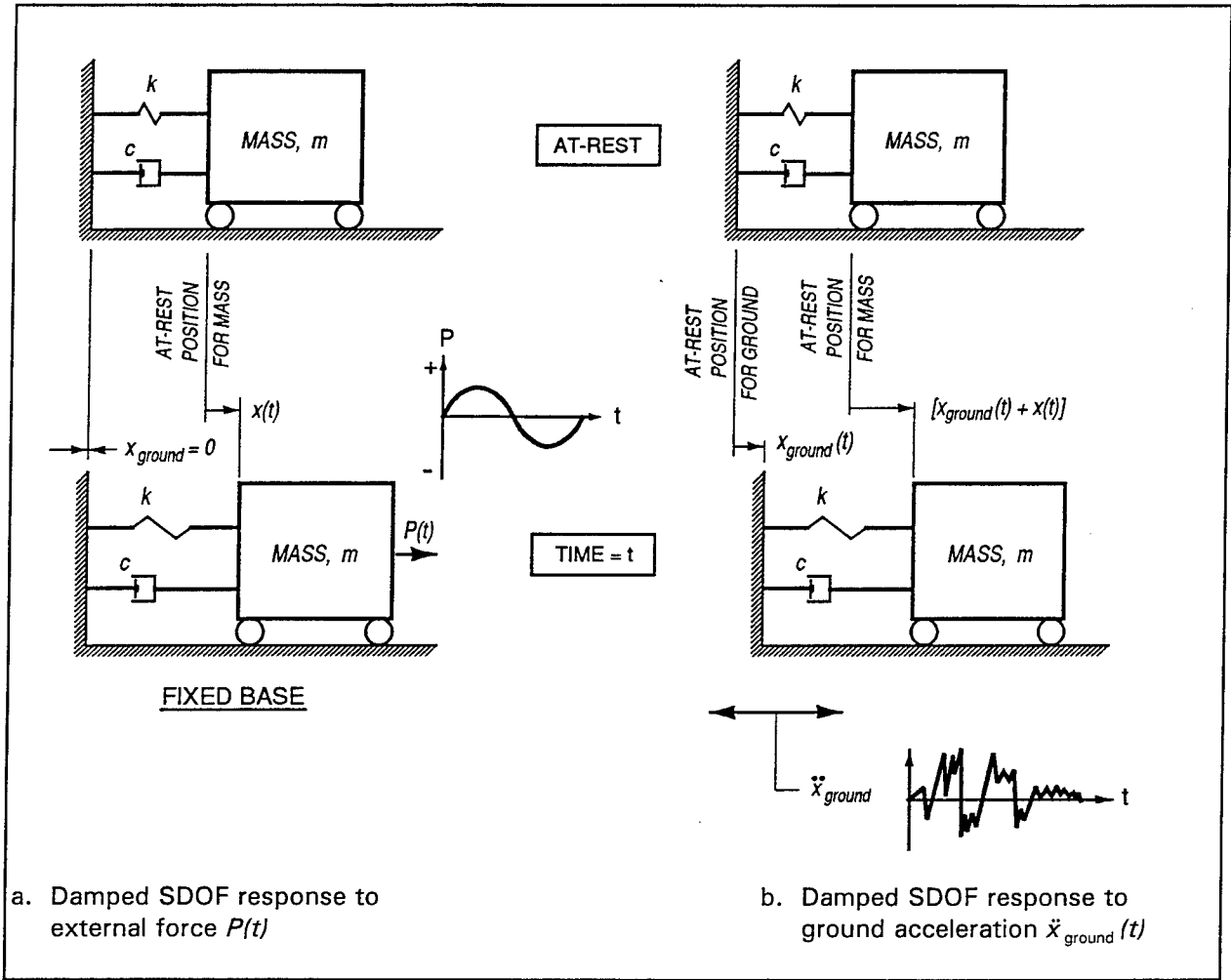

Figure 1. Dynamic response of two damped SDOF systems (Ebeling 1992)

k = stiffness of the SDOF system

$x(t)$ = relative displacement of the mass

Figure 3 shows that inertial force f_i acts opposite to the acceleration of mass m at time t .

Substituting the expressions given in Equation 2 into Equation 1 results in the equation of motion for an SDOF system:

$$m\ddot{x}(t) + c\dot{x}(t) + kx(t) = P(t) \quad (3)$$

For earthquake analyses, the dynamic loading is represented by

$$P(t) = -m\ddot{x}_{ground}(t) \quad (4)$$

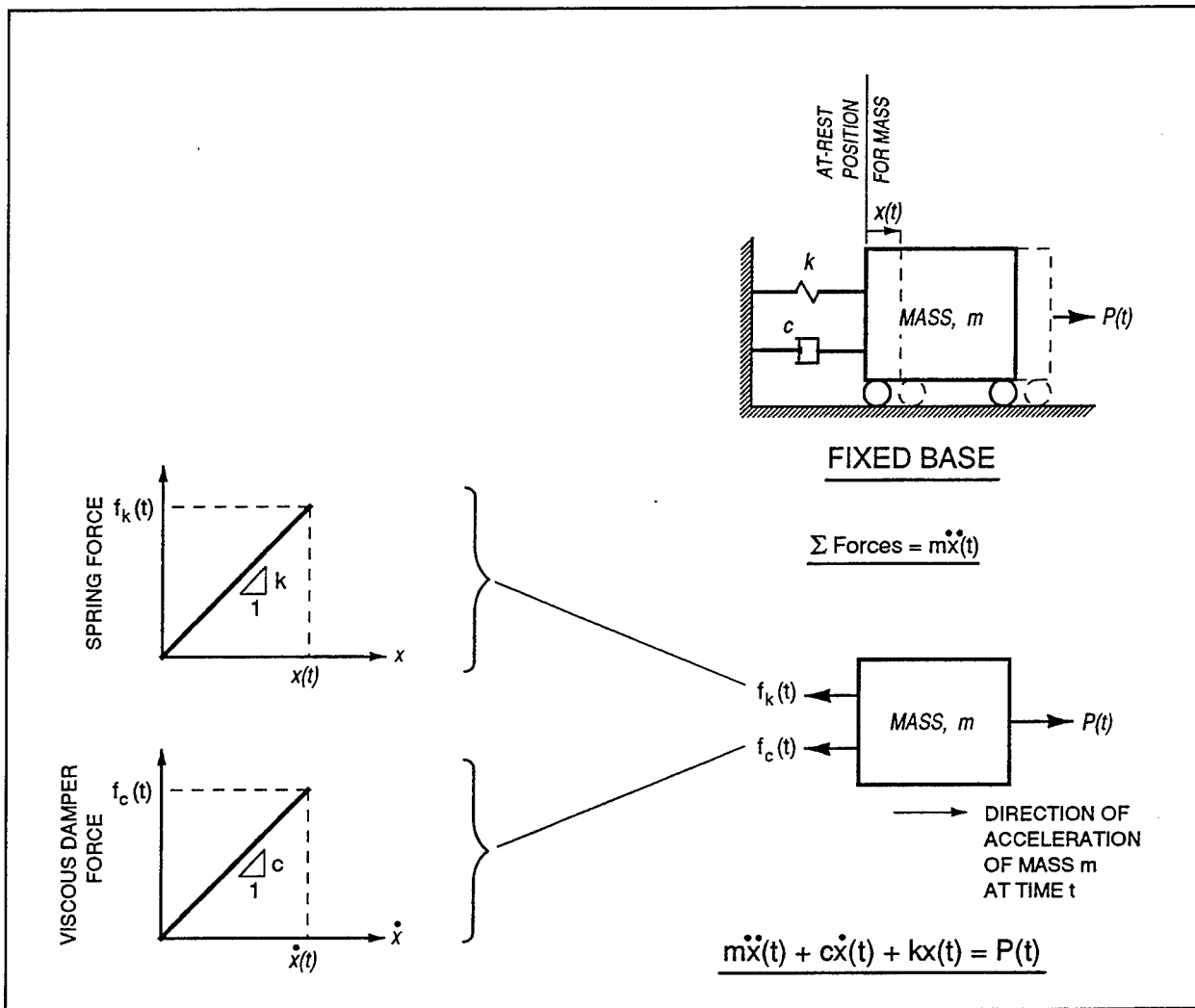

Figure 2. Forces acting on linear SDOF system at time t , external force $P(t)$ applied (Ebeling 1992)

where $\ddot{x}_{\text{ground}}(t)$ is the ground acceleration applied to the base of the SDOF system, and thus the equation of motion becomes

$$m\ddot{x}(t) + c\dot{x}(t) + kx(t) = -m\ddot{x}_{\text{ground}}(t) \quad (5)$$

Figure 4 depicts these equivalent dynamic SDOF system problems. In alternate form, the equation of motion may be written

$$\ddot{x}(t) + 2\beta\omega\dot{x}(t) + \omega^2x(t) = -\ddot{x}_{\text{ground}}(t) \quad (6)$$

where

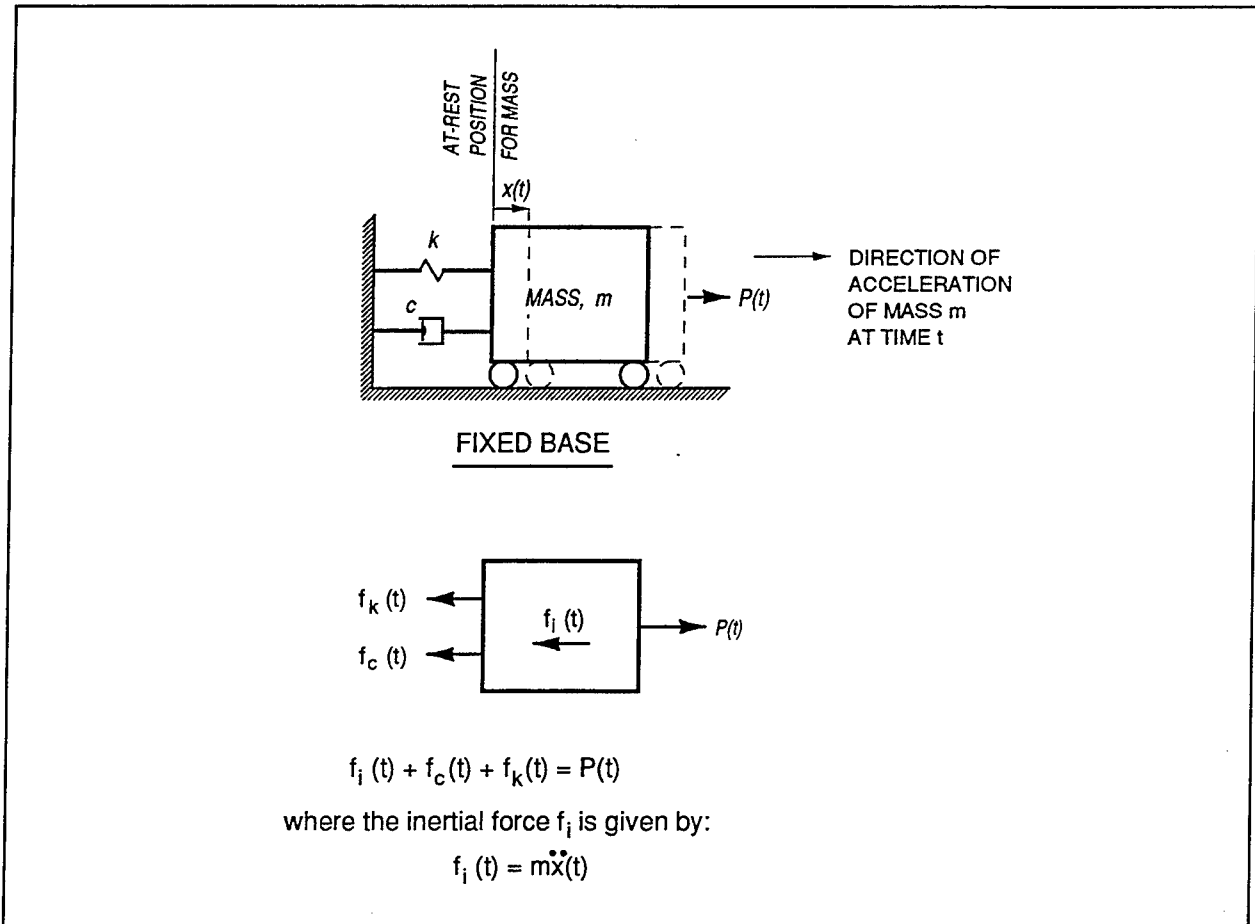

Figure 3. Inertial force acting opposite to the acceleration of mass m at time t , external force $P(t)$ applied (Ebeling 1992)

$$\beta = \text{damping ratio} = c/(2m\omega)$$

$$\omega = \text{circular frequency} = \sqrt{k/m}$$

$$c = 2m\omega\beta$$

and

$$T_o = \frac{2\pi}{\omega} = 2\pi\sqrt{\frac{m}{k}} \quad (7)$$

In earthquake analyses, parameters of interest are relative displacement, relative velocity, and total acceleration. The total acceleration, $\ddot{x}_{\text{total}}(t)$, is simply the sum of the relative acceleration plus the ground acceleration

$$\begin{aligned} \ddot{x}_{\text{total}}(t) &= \ddot{x}_{\text{ground}}(t) + \ddot{x}(t) \\ &= -\{2\beta\omega\dot{x}(t) + \omega^2x(t)\} \end{aligned} \quad (8)$$

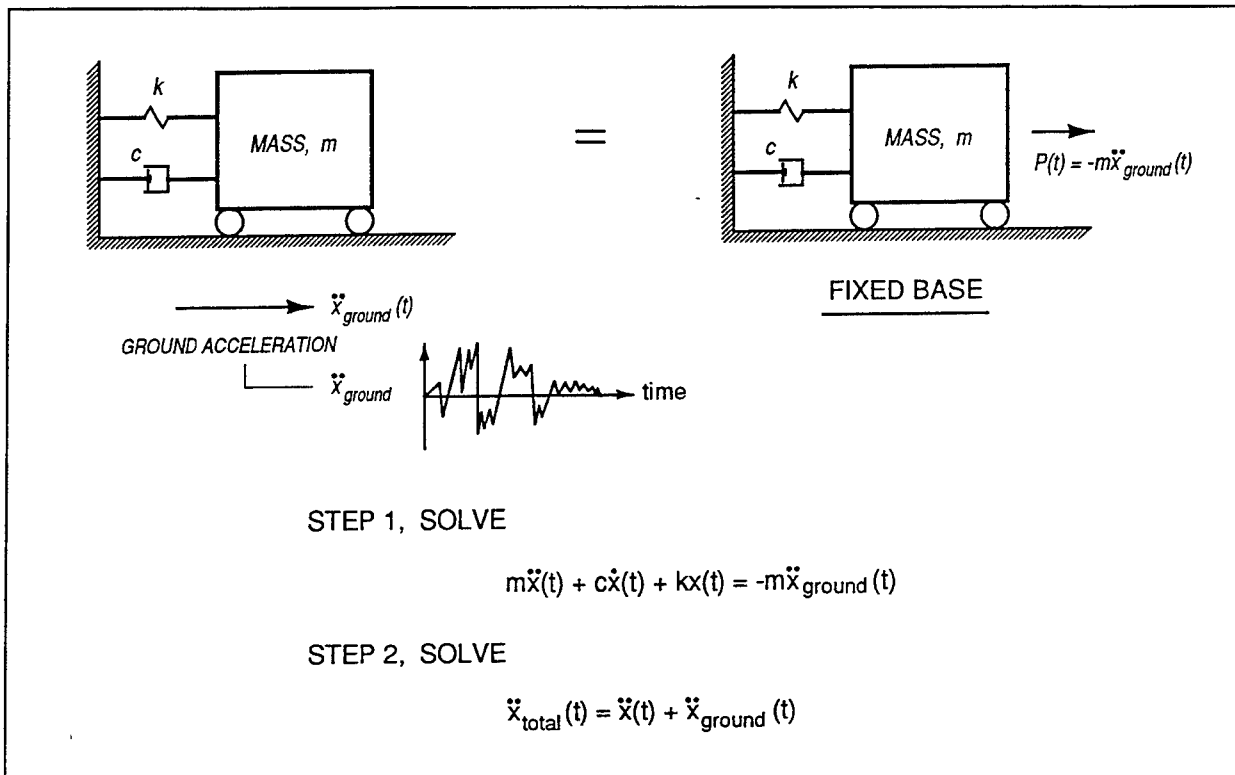

Figure 4. Equivalent dynamic SDOF system problems (Ebeling 1992)

For computer analyses, the discretized form of these equations is needed and may be represented by the following notation:

$$x_i = x(t_i), \dot{x}_i = \dot{x}(t_i), \ddot{x}_i = \ddot{x}(t_i), \ddot{x}_{ground\ i} = \ddot{x}_{ground}(t_i), \text{ and } \ddot{x}_{total\ i} = \ddot{x}_{total}(t_i) \quad (9)$$

where

$$t_i = i \Delta t, \Delta t = t_{i+1} - t_i \quad (10)$$

and $i = \text{integer}$.

2.2 Newmark β Method

The Newmark β method is based on the following equations (e.g., Chopra 1995):

$$\dot{x}_{i+1} = \dot{x}_i + [(1 - \gamma)\Delta t] \ddot{x}_i + (\gamma\Delta t) \ddot{x}_{i+1} \quad (11)$$

and

$$x_{i+1} = x_i + (\Delta t)\dot{x}_i + [(0.5 - \beta)\Delta t^2]\ddot{x}_i + (\beta\Delta t^2)\ddot{x}_{i+1} \quad (12)$$

where the parameters¹ β and γ define the variation of response acceleration over the time-step and control the stability and accuracy of the method. Typically, γ is set equal to 1/2, which corresponds to zero artificial damping, and β is set to a value between 1/6 and 1/4. In the analyses performed in this report $\gamma = 1/2$ and $\beta = 1/6$ were used, which corresponds to a linear variation of response acceleration over the time-step (i.e., the linear acceleration method). The original 1959 version of the Newmark- β family of numerical methods required iteration to implement Equations 11 and 12. However, a modification can be made to avoid iterations. This modified formulation is described in this section.

Equations 14 and 15 result from using the following definitions:

$$\begin{aligned} \Delta x_i &\equiv x_{i+1} - x_i, \quad \Delta \dot{x}_i \equiv \dot{x}_{i+1} - \dot{x}_i, \\ \Delta \ddot{x}_i &\equiv \ddot{x}_{i+1} - \ddot{x}_i, \quad \text{and} \quad \Delta P_i \equiv P_{i+1} - P_i \end{aligned} \quad (13)$$

into which Equations 11 and 12 are substituted.

$$\Delta \dot{x}_i = \Delta t \ddot{x}_i + \gamma \Delta t \Delta \ddot{x}_i \quad (14)$$

$$\Delta x_i = \Delta t \dot{x}_i + \frac{\Delta t^2}{2} \ddot{x}_i + \beta \Delta t^2 \Delta \ddot{x}_i \quad (15)$$

Solving Equation 15 for $\Delta \ddot{x}_i$

$$\Rightarrow \Delta \ddot{x}_i = \frac{1}{\beta \Delta t^2} \Delta x_i - \frac{1}{\beta \Delta t} \dot{x}_i - \frac{1}{2\beta} \ddot{x}_i \quad (16)$$

and then substituting into the last term of Equation 14 gives

$$\Delta \dot{x}_i = \frac{\gamma}{\beta \Delta t} \Delta x_i - \frac{\gamma}{\beta} \dot{x}_i + \Delta t \left(1 - \frac{\gamma}{2\beta} \right) \ddot{x}_i \quad (17)$$

The incremental equation of motion (Equation 18) can be derived from Equation 3 and Equation 13:

$$m \Delta \ddot{x}_i + c \Delta \dot{x}_i + k \Delta x_i = \Delta P_i \quad (18)$$

¹ Note that in Equation 12 and all subsequent equations in this section, the variable β describes how the acceleration response of the SDOF system varies over the time-step and does not refer to the damping ratio, represented by β in the other sections of this report.

Substituting Equations 16 and 17 into the incremental equation of motion gives

$$\begin{aligned} \left(k + c \frac{\gamma}{\beta \Delta t} + m \frac{1}{\beta \Delta t^2} \right) \Delta x_i = \Delta P_i + \left(\frac{1}{\beta \Delta t} m + \frac{\gamma}{\beta} c \right) \dot{x}_i \\ + \left[\frac{1}{2\beta} m + \Delta t \left(\frac{\gamma}{2\beta} - 1 \right) c \right] \ddot{x}_i \end{aligned} \quad (19)$$

Equation 19 can be rewritten as

$$\bar{k} \Delta x_i = \Delta \bar{P}_i \quad (20)$$

where \bar{k} is referred to as the “effective” stiffness

$$\bar{k} = k + c \frac{\gamma}{\beta \Delta t} + m \frac{1}{\beta \Delta t^2} \quad (21)$$

and $\Delta \bar{P}_i$ is referred to as the “effective” incremental force

$$\Delta \bar{P}_i = \Delta P_i + \left(\frac{1}{\beta \Delta t} m + \frac{\gamma}{\beta} c \right) \dot{x}_i + \left[\frac{1}{2\beta} m + \Delta t \left(\frac{\gamma}{2\beta} - 1 \right) c \right] \ddot{x}_i \quad (22)$$

Accordingly, the incremental change in displacement Δx_i from t_i to t_{i+1} may be determined by rearranging Equation 20 and from knowledge of the velocity and acceleration at t_i

$$\Rightarrow \Delta x_i = \frac{\Delta \bar{P}_i}{\bar{k}} \quad (23)$$

Once Δx_i is determined, the incremental change in velocity $\Delta \dot{x}_i$ and acceleration $\Delta \ddot{x}_i$ from t_i to t_{i+1} may be computed using Equations 17 and 16, respectively. Rearranging Equation 13 and substituting in the values for $\Delta \dot{x}_i$ and $\Delta \ddot{x}_i$, the response velocity and acceleration at t_{i+1} can be established.

$$\Rightarrow \dot{x}_{i+1} = \dot{x}_i + \Delta \dot{x}_i \quad \text{and} \quad \ddot{x}_{i+1} = \ddot{x}_i + \Delta \ddot{x}_i \quad (24)$$

There are different types of numerical methods in the Newmark β family depending on the values assigned to β and γ (Hughes and Belytschko 1983; Hughes 1987; Subbaraj and Dokainish 1989b; and Chopra 1995). When the constant β is set equal to 1/2 and the constant γ is set equal to 1/6, this particular variation of

the Newmark β family of numerical methods is referred to as the linear acceleration method. The linear acceleration method is used in the numerical studies to be reported on in subsequent chapters.

2.3 Wilson θ Method

Although the Newmark β method is versatile and accurate, when used with β and γ values that correspond to the linear acceleration method, the method is only conditionally stable, i.e., a time-step Δt shorter than some stability limit must be used to ensure that the solutions are bounded¹ (e.g., Paz 1991 or Chopra 1995). (This potential for instability is inherent in the linear acceleration method and not an artifact of the Newmark β method's formulation.) However, an unconditionally stable form of the linear acceleration method is the Wilson θ method; for $\theta \geq 1.37$, the solution is bounded regardless of the size of the time-step. The modification that Wilson introduced is based on the assumption that the response acceleration varies linearly over an extended time interval from t to $t + \theta\Delta t$, where $\theta > 1.0$. Note that for $\theta = 1.0$, the Wilson θ method is the same as the Newmark β method when $\beta = 1/6$ and $\gamma = 1/2$.

Writing the equilibrium criteria for an SDOF system at t_i and $t_i + \theta\Delta t$, Equation 3 becomes

$$f_i(t_i) + f_c(t_i) + f_k(t_i) = P(t_i) \quad (25)$$

and

$$f_i(t_i + \theta\Delta t) + f_c(t_i + \theta\Delta t) + f_k(t_i + \theta\Delta t) = P(t_i + \theta\Delta t) \quad (26)$$

Subtracting Equation 25 from Equation 26 gives

$$\hat{\Delta}f_i + \hat{\Delta}f_c + \hat{\Delta}f_k = \hat{\Delta}P \quad (27)$$

where

$$\hat{\Delta}f_i = f_i(t_i + \theta\Delta t) - f_i(t_i), \text{ etc.} \quad (28)$$

¹ The stability limit for the linear acceleration method is $\Delta t < \Delta t_{\text{critical}}$, with $\Delta t_{\text{critical}} = 0.551(T_o)$. For the analyses of SDOF systems performed in this report, stability requirements are easily satisfied as will be demonstrated in Chapter 3. However, for the higher modes of vibration in MDOF systems or high-frequency SDOF systems, stability may be an issue.

Accordingly, the *extended* incremental form of Equation 29 may be written as

$$\hat{\Delta}f_i = m \hat{\Delta}\ddot{x} , \quad \hat{\Delta}f_c = c \hat{\Delta}\dot{x} , \quad \text{and} \quad \hat{\Delta}f_k = k \hat{\Delta}x \quad (29)$$

where

$$\hat{\Delta}x_i = x(t_i + \theta\Delta t) - x(t_i) , \quad \text{etc.} \quad (30)$$

and the *extended* incremental form of the equation of motion becomes

$$m \hat{\Delta}\ddot{x}_i + c \hat{\Delta}\dot{x}_i + k \hat{\Delta}x_i = \hat{\Delta}P_i \quad (31)$$

Assuming that the response acceleration varies linearly over an extended time interval from t to $t + \theta\Delta t$,

$$\ddot{x}(t) = \ddot{x}_i + \frac{\hat{\Delta}\ddot{x}_i}{\theta\Delta t} (t - t_i) \quad \text{for} \quad t_i \leq t \leq t_i + \theta\Delta t \quad (32)$$

the response velocity and displacement are given by:

$$\dot{x}(t) = \dot{x}_i + \ddot{x}_i(t - t_i) + \frac{1}{2} \frac{\hat{\Delta}\ddot{x}_i}{\theta\Delta t} (t - t_i)^2 \quad (33)$$

and

$$x(t) = x_i + \dot{x}_i(t - t_i) + \frac{1}{2} \ddot{x}_i(t - t_i)^2 + \frac{1}{6} \frac{\hat{\Delta}\ddot{x}_i}{\theta\Delta t} (t - t_i)^3 \quad (34)$$

Evaluating the response velocity (i.e., Equation 33) at t_i and $t_i + \theta\Delta t$ results in

$$\dot{x}(t_i) = \dot{x}_i \quad (35)$$

and

$$\dot{x}(t_i + \theta\Delta t) = \dot{x}_i + \ddot{x}_i\theta\Delta t + \frac{1}{2} \hat{\Delta}\ddot{x}_i \quad (36)$$

The *extended* incremental response velocity may be obtained by subtracting Equation 35 from Equation 36:

$$\hat{\Delta}\dot{x}_i = \ddot{x}_i\theta\Delta t + \frac{1}{2}\hat{\Delta}\ddot{x}_i\theta\Delta t \quad (37)$$

In a similar fashion, the *extended* incremental response displacement is determined to be

$$\hat{\Delta}x = \dot{x}_i\theta\Delta t + \frac{1}{2}\ddot{x}_i(\theta\Delta t)^2 + \frac{1}{6}\hat{\Delta}\ddot{x}_i(\theta\Delta t)^2 \quad (38)$$

Solving Equation 38 for the *extended* incremental response acceleration,

$$\Rightarrow \hat{\Delta}\ddot{x}_i = \frac{6}{(\theta\Delta t)^2}\hat{\Delta}x_i - \frac{6}{(\theta\Delta t)}\dot{x}_i - 3\ddot{x}_i \quad (39)$$

and then substituting this expression into the last term of Equation 37 gives

$$\hat{\Delta}\dot{x}_i = \frac{3}{\theta\Delta t}\hat{\Delta}x_i - 3\dot{x}_i - \frac{\theta\Delta t}{2}\ddot{x}_i \quad (40)$$

Substituting Equations 39 and 40 into the *extended* incremental equation of motion (i.e., Equation 31) gives

$$\begin{aligned} \left(k + \frac{6}{\theta\Delta t}m + \frac{3}{\theta\Delta t}c\right)\hat{\Delta}x_i &= \hat{\Delta}P_i \\ &+ m\left(\frac{6}{\theta\Delta t}\dot{x}_i + 3\ddot{x}_i\right) + c\left(3\dot{x}_i + \frac{\theta\Delta t}{2}\ddot{x}_i\right) \end{aligned} \quad (41)$$

Equation 41 can be rewritten as

$$\bar{k}\hat{\Delta}x_i = \hat{\Delta}\bar{P}_i \quad (42)$$

where \bar{k} is again referred to as the “effective” stiffness but defined as

$$\bar{k} = k + \frac{6}{\theta \Delta t} m + \frac{3}{\theta \Delta t} c \quad (43)$$

and $\Delta \bar{P}_i$ is again referred to as the “effective” incremental force but defined as

$$\hat{\Delta \bar{P}}_i = \hat{\Delta P}_i + m \left(\frac{6}{\theta \Delta t} \dot{x}_i + 3\ddot{x}_i \right) + c \left(3\dot{x}_i + \frac{\theta \Delta t}{2} \ddot{x}_i \right) \quad (44)$$

Accordingly, the incremental change in displacement $\hat{\Delta x}_i$ from t_i to $t_i + \theta \Delta t$ may be determined by rearranging Equation 42 and from knowledge of the velocity and acceleration at t_i .

$$\rightarrow \hat{\Delta x}_i = \frac{\hat{\Delta \bar{P}}_i}{\bar{k}_i} \quad (45)$$

Once the *extended* incremental change in displacement is known, Equation 39 may be used to compute the *extended* incremental change in acceleration. The incremental change in acceleration is related to the *extended* incremental change in acceleration through Equation 46:

$$\Delta \ddot{x}_i = \frac{\hat{\Delta \ddot{x}}_i}{\theta} \quad (46)$$

The remaining response quantities of interest may be computed by the following expressions:

$$\Delta \dot{x}_i = \dot{x}_i \Delta t + \frac{1}{2} \Delta \ddot{x}_i \Delta t \quad (47)$$

$$\Delta x_i = \dot{x}_i \Delta t + \frac{1}{2} \ddot{x}_i \Delta t^2 + \frac{1}{6} \Delta \ddot{x}_i \Delta t^2 \quad (48)$$

$$x_{i+1} = x_i + \Delta x_i \quad (49)$$

$$\dot{x}_{i+1} = \dot{x}_i + \Delta \dot{x}_i \quad (50)$$

and

$$\ddot{x}_{i+1} = \frac{1}{m} (P_{i+1} - c\dot{x}_{i+1} - kx_{i+1}) \quad (51)$$

2.4 Central Difference Method

The Central Difference Method is based on the finite difference approximation of the time derivatives of displacement, i.e., velocity and acceleration (e.g., Chopra 1995). The central difference expressions for velocity and acceleration at time t_i are:

$$\dot{x}_i = \frac{x_{i+1} - x_{i-1}}{2\Delta t}$$

and (52)

$$\ddot{x}_i = \frac{x_{i+1} - 2x_i + x_{i-1}}{\Delta t^2}$$

where at $t_i = 0$, the initial response quantities x_0 and \dot{x}_0 are assumed known¹ and x_{-1} is given by

$$x_{-1} = x_0 - \Delta t \dot{x}_0 + \frac{\Delta t^2}{2} \ddot{x}_0 \quad (53)$$

When the expressions in Equation 52 are substituted in Equation 3, the discretized equation of motion may be written:

$$m \frac{x_{i+1} - 2x_i + x_{i-1}}{\Delta t^2} + c \frac{x_{i+1} - x_{i-1}}{2\Delta t} + kx_i = P_i \quad (54)$$

or alternately,

$$\left(\frac{m}{\Delta t^2} + \frac{c}{2\Delta t} \right) x_{i+1} = P_i - \left(\frac{m}{\Delta t^2} - \frac{c}{2\Delta t} \right) x_{i-1} - \left(k - \frac{2m}{\Delta t^2} \right) x_i \quad (55)$$

As with the formulations of the Newmark β and Wilson θ methods, the equation of motion can be represented in an analogous form to Hooke's law:

$$\bar{k} x_{i+1} = \bar{P}_i \quad (56)$$

¹ The initial value for relative acceleration (\ddot{x}_0) may be determined by substituting the known values of x_0 and \dot{x}_0 into the equation of motion.

where \bar{k} , again the “effective” stiffness, is written as

$$\bar{k} = \frac{m}{\Delta t^2} + \frac{c}{2\Delta t} \quad (57)$$

and \bar{P}_i , again the “effective” force, is written as

$$\bar{P}_i = P_i - \left(\frac{m}{\Delta t^2} - \frac{c}{2\Delta t} \right) x_{i-1} - \left(k - \frac{2m}{\Delta t^2} \right) x_i \quad (58)$$

Solving Equation 56 for relative displacement,

$$\Rightarrow x_{i+1} = \frac{\bar{P}_i}{\bar{k}} \quad (59)$$

Because the Central Difference Method is based on the finite difference approximation of the time derivatives of displacement, the determination of relative velocity and acceleration lags the determination of relative displacement by Δt (i.e., x_{i+1} is needed to compute \dot{x}_i and \ddot{x}_i). However, once x_{i+1} is known, \dot{x}_i and \ddot{x}_i may be computed using the expressions in Equation 52:

$$\dot{x}_i = \frac{x_{i+1} - x_{i-1}}{2\Delta t} \quad \text{and} \quad \ddot{x}_i = \frac{x_{i+1} - 2x_i + x_{i-1}}{\Delta t^2} \quad (52 \text{ bis})$$

2.5 Duhamel's Integral

Duhamel's integral method, solved in a piecewise exact fashion, idealizes the forcing function as a succession of short-duration impulses, with each short-duration impulse being followed by a free vibration response (e.g., Paz 1985; Ebeling 1992; or Clough and Penzien 1993). Superposition is used to combine each of the short-duration impulse/free vibration responses with the total response for the structural model. For a continuous forcing function, $P(t)$ is divided into a series of pulses of duration $d\tau$. The change in velocity of the SDOF system due to the impulsive load may be determined from Newton's law of motion:

$$m \frac{d\dot{x}}{d\tau} = P(\tau) \quad (60)$$

or

$$d\dot{x} = \frac{P(\tau) d\tau}{m} \quad (61)$$

where $P(\tau) d\tau$ is the impulse, and $d\dot{x}$ is the incremental velocity. This incremental velocity may be considered to be an initial velocity of the SDOF system at time τ .

The solution to the equation of motion for free vibration is

$$x(t) = e^{-\beta\omega t} \left[x_0 \cos(\omega_D t) + \frac{\dot{x}_0 + x_0 \beta \omega}{\omega_D} \sin(\omega_D t) \right] \quad (62)$$

where

$$\omega_D = \omega \sqrt{1 - \beta^2} \quad (63)$$

Substituting Equation 61 for \dot{x}_0 in the second term of Equation 62 and assuming $x_0 = 0$ results in

$$dx(t) = e^{-\beta\omega(t-\tau)} \frac{P(\tau) d\tau}{m\omega_D} \sin \omega_D(t-\tau) \quad (64)$$

The total relative displacement can be determined by summing the differential responses, given by Equation 64, over the entire loading interval:

$$x(t) = \frac{1}{m\omega_D} \int_0^t P(\tau) e^{-\beta\omega(t-\tau)} \sin \omega_D(t-\tau) d\tau \quad (65)$$

Using the trigonometric identity:

$$\sin \omega(t-\tau) = \sin \omega t \cos \omega \tau - \cos \omega t \sin \omega \tau \quad (66)$$

Equation 65 may be written

$$x(t) = \frac{e^{-\beta\omega t}}{m\omega_D} \left[A_D(t) \sin \omega_D t - B_D(t) \cos \omega_D t \right] \quad (67)$$

where

$$A_D(t) = \int_0^t P(\tau) e^{\beta\omega\tau} \cos \omega_D \tau \, d\tau$$

and

$$B_D(t) = \int_0^t P(\tau) e^{\beta\omega\tau} \sin \omega_D \tau \, d\tau$$

The expressions in Equation 68 can be solved by several techniques. For this study, the loading function $P(\tau)$ is assumed to be piecewise linear and an exact solution formulated.

$$P(\tau) = P(t_{i-1}) + \frac{\Delta P_i}{\Delta t} (\tau - t_{i-1}) \quad \text{for } t_{i-1} \leq \tau \leq t_i \quad (69)$$

where

$$\Delta P_i = P(t_i) - P(t_{i-1}) \quad (70)$$

When Equation 69 is substituted into the expressions of Equation 68 and the intermediate variables I_1 , I_2 , I_3 , and I_4 given in Equation 71 are used, Equation 72 represents an exact solution.

$$I_1 = \int_{t_{i-1}}^{t_i} e^{\beta\omega\tau} \cos \omega_D \tau \, d\tau = \frac{e^{\beta\omega\tau}}{(\beta\omega)^2 + \omega_D^2} (\beta\omega \cos \omega_D \tau + \omega_D \sin \omega_D \tau) \Big|_{t_{i-1}}^{t_i}$$

$$I_2 = \int_{t_{i-1}}^{t_i} e^{\beta\omega\tau} \sin \omega_D \tau \, d\tau = \frac{e^{\beta\omega\tau}}{(\beta\omega)^2 + \omega_D^2} (\beta\omega \sin \omega_D \tau - \omega_D \cos \omega_D \tau) \Big|_{t_{i-1}}^{t_i} \quad (71)$$

$$I_3 = \int_{t_{i-1}}^{t_i} \tau e^{\beta\omega\tau} \sin \omega_D \tau \, d\tau = \left[\tau - \frac{\beta\omega}{(\beta\omega)^2 + \omega_D^2} \right] I_2' + \frac{\omega_D}{(\beta\omega_D)^2 + \omega_D^2} I_1' \Big|_{t_{i-1}}^{t_i}$$

$$I_4 = \int_{t_{i-1}}^{t_i} \tau e^{\beta\omega\tau} \cos \omega_D \tau \, d\tau = \left[\tau - \frac{\beta\omega}{(\beta\omega)^2 + \omega_D^2} \right] I_1' + \frac{\omega_D}{(\beta\omega_D)^2 + \omega_D^2} I_2' \Big|_{t_{i-1}}^{t_i}$$

where I'_1 and I'_2 are the integrals for I_1 and I_2 before their evaluation at the limits. By introducing the following relationships

$$A_D(t_i) = A_D(t_{i-1}) + \left[P(t_{i-1}) - t_{i-1} \frac{\Delta P_i}{\Delta t} \right] I_1 + \frac{\Delta P_i}{\Delta t} I_4 \quad (72)$$

$$B_D(t_i) = B_D(t_{i-1}) + \left[P(t_{i-1}) - t_{i-1} \frac{\Delta P_i}{\Delta t} \right] I_2 + \frac{\Delta P_i}{\Delta t} I_3$$

the relative displacement, velocity, and acceleration may be determined using Equations 73, 74, and 75, respectively.

$$x_i = \frac{e^{-\beta \omega t_i}}{m \omega_D} \left[A_D(t_i) \sin \omega_D t_i - B_D(t_i) \cos \omega_D t_i \right] \quad (73)$$

$$\begin{aligned} \dot{x}_i = \frac{e^{-\beta \omega t_i}}{m \omega_D} \left\{ \left[\omega_D B_D(t_i) - \beta \omega A_D(t_i) \right] \sin \omega_D t_i \right. \\ \left. + \left[\omega_D A_D(t_i) + \beta \omega B_D(t_i) \right] \cos \omega_D t_i \right\} \quad (74) \end{aligned}$$

$$\ddot{x}_i = \frac{1}{m} (P_i - c \dot{x}_i - k x_i) \quad (75)$$

2.6 Piecewise Exact Method

The Piecewise Exact Method is similar to the way Duhamel's integral was solved in the previous section: the forcing function is assumed to vary linearly in a piecewise fashion and based on this assumption, an exact solution is determined (Nigam and Jennings 1968 and summarized in Appendix A of Gupta 1992). However, the Piecewise Exact Method is a direct formulation and does not require the loading to be divided into a series of impulses, as was done in the formulation of Duhamel's integral.

Assuming the dynamic loading varies in a piecewise linear fashion:

$$P(t) = P(t_i) + \frac{\Delta P_i}{\Delta t} (t - t_i) \quad \text{for} \quad t_i \leq t \leq t_{i+1} \quad (76)$$

where

$$\Delta P_i = P_{i+1} - P_i \quad (77)$$

The relative displacement and velocity may be determined by

$$X_{i+1} = AX_i + B\ddot{X}_{\text{ground } i} \quad (78)$$

where

$$X_i = \begin{Bmatrix} x_i \\ \dot{x}_i \end{Bmatrix} \quad \ddot{X}_{\text{ground } i} = -\frac{1}{m} \begin{Bmatrix} P_i \\ P_{i+1} \end{Bmatrix} \quad (79)$$

and

$$A = \begin{bmatrix} a_{11} & a_{12} \\ a_{21} & a_{22} \end{bmatrix} \quad B = \begin{bmatrix} b_{11} & b_{12} \\ b_{21} & b_{22} \end{bmatrix} \quad (80)$$

The elements of the matrices A and B are given by the expressions in Equations 81 and 82, respectively:

$$\begin{aligned} a_{11} &= e^{-\beta\omega\Delta t} \left(\frac{\omega\beta}{\omega_D} \sin \omega_D \Delta t + \cos \omega_D \Delta t \right) \\ a_{12} &= \frac{e^{-\beta\omega\Delta t}}{\omega_D} \sin \omega_D \Delta t \\ a_{21} &= -\frac{\omega^2 e^{-\beta\omega\Delta t}}{\omega_D} \sin \omega_D \Delta t \\ a_{22} &= e^{-\beta\omega\Delta t} \left(\cos \omega_D \Delta t - \frac{\omega\beta}{\omega_D} \sin \omega_D \Delta t \right) \end{aligned} \quad (81)$$

and

$$\begin{aligned}
b_{11} &= e^{-\beta\omega\Delta t} \left[\left(\frac{2\beta^2 - 1}{\omega^2\Delta t} + \frac{\beta}{\omega} \right) \frac{\sin \omega_D \Delta t}{\omega_D} + \left(\frac{2\beta}{\omega^3\Delta t} + 1 \right) \cos \omega_D \Delta t \right] - \frac{2\beta}{\omega^3\Delta t} \\
b_{12} &= -e^{-\beta\omega\Delta t} \left[\left(\frac{2\beta^2 - 1}{\omega^2\Delta t} \right) \frac{\sin \omega_D \Delta t}{\omega_D} + \frac{2\beta}{\omega^3\Delta t} \cos \omega_D \Delta t \right] - \frac{1}{\omega^2} - \frac{2\beta}{\omega^3\Delta t} \\
b_{21} &= e^{-\beta\omega\Delta t} \left[\left(\frac{2\beta^2 - 1}{\omega^2\Delta t} + \frac{\beta}{\omega} \right) \left(\cos \omega_D \Delta t - \frac{\omega\beta}{\omega_D} \sin \omega_D \Delta t \right) \right. \\
&\quad \left. - \left(\frac{2\beta}{\omega^3\Delta t} + \frac{1}{\omega^2} \right) (\omega_D \sin \omega_D \Delta t + \beta\omega \cos \omega_D \Delta t) \right] + \frac{1}{\omega^2\Delta t} \\
b_{22} &= -e^{-\beta\omega\Delta t} \left[\frac{2\beta^2 - 1}{\omega^2\Delta t} \left(\cos \omega_D \Delta t - \frac{\omega\beta}{\omega_D} \sin \omega_D \Delta t \right) \right. \\
&\quad \left. - \frac{2\beta}{\omega^3\Delta t} (\omega_D \sin \omega_D \Delta t + \beta\omega \cos \omega_D \Delta t) \right] - \frac{1}{\omega^2\Delta t}
\end{aligned} \tag{82}$$

Once the relative displacement and velocity have been determined, the relative acceleration may be computed by

$$\ddot{x}_{i+1} = \frac{1}{m} (P_{i+1} - c\dot{x}_{i+1} - kx_{i+1}) \tag{83}$$

2.7 4th Order Runge-Kutta Method

In the application of the 4th Order Runge-Kutta method, the equation of motion is first reduced to two first-order differential equations (Thomson 1993). Writing the equation of motion as

$$\ddot{x}(t) = \frac{1}{m} [P(t) - kx(t) - c\dot{x}(t)] = F(x, \dot{x}, t) \tag{84}$$

this second-order differential equation may be written as two first-order equations:

$$\begin{aligned} \dot{x}(t) &= y(t) \\ \dot{y}(t) &= F(x, y, t) \end{aligned} \quad (85)$$

Both x_{i+1} and y_{i+1} can be expressed in terms of the Taylor series:

$$\begin{aligned} x(t_{i+1}) &= x(t_i) + \left(\frac{dx}{dt} \right)_{t_i} \Delta t + \left(\frac{d^2x}{dt^2} \right)_{t_i} \frac{\Delta t^2}{2} + \dots \\ y(t_{i+1}) &= y(t_i) + \left(\frac{dy}{dt} \right)_{t_i} \Delta t + \left(\frac{d^2y}{dt^2} \right)_{t_i} \frac{\Delta t^2}{2} + \dots \end{aligned} \quad (86)$$

Ignoring the higher order derivatives, and replacing the first derivative by an "average" slope, the expressions in Equation 86 may be written:

$$\begin{aligned} x(t_{i+1}) &= x(t_i) + \left(\frac{dx}{dt} \right)_{avg} \Delta t \\ y(t_{i+1}) &= y(t_i) + \left(\frac{dy}{dt} \right)_{avg} \Delta t \end{aligned} \quad (87)$$

where, if Simpson's rule were used, the "average" slope would be defined as

$$\left(\frac{dy}{dt} \right)_{avg} = \frac{1}{6} \left[\left(\frac{dy}{dt} \right)_{t_i} + 4 \left(\frac{dy}{dt} \right)_{t_i+h/2} + \left(\frac{dy}{dt} \right)_{t_i+h} \right] \quad (88)$$

In the Runge-Kutta formulation, the "average" slope is very similar to that of the Simpson's rule, except that the center term of Equation 88 is split into two terms and four values of t , x , y , and F are computed for each point i as follows:

t	x	$y = \dot{x}$	$\dot{y} = \ddot{x}$
$T_1 = t_i$	$X_1 = x_i$	$Y_1 = y_i$	$F_1 = F(T_1, X_1, Y_1)$
$T_2 = t_i + h/2$	$X_2 = x_i + Y_1 h/2$	$Y_2 = y_i + F_1 h/2$	$F_2 = F(T_2, X_2, Y_2)$
$T_3 = t_i + h/2$	$X_3 = x_i + Y_2 h/2$	$Y_3 = y_i + F_2 h/2$	$F_3 = F(T_3, X_3, Y_3)$
$T_4 = t_i + h$	$X_4 = x_i + Y_3 h$	$Y_4 = y_i + F_3 h$	$F_4 = F(T_4, X_4, Y_4)$

These quantities are then used in the following recurrence equations:

$$x_{i+1} = x_i + \frac{\Delta t}{6} (Y_1 + 2Y_2 + 2Y_3 + Y_4) \quad (89)$$

$$\dot{x}_{i+1} = y_{i+1} = y_i + \frac{\Delta t}{6} (F_1 + 2F_2 + 2F_3 + F_4)$$

where it is recognized that the four values of Y divided by 6 represent an “average” slope dx/dt and the four values of F divided by 6 represent an “average” slope dy/dt . Once the values of the expressions in Equation 89 are determined, the relative acceleration at time t_{i+1} may be computed:

$$\ddot{x}_{i+1} = \frac{1}{m} (P_{i+1} - kx_{i+1} - c\dot{x}_{i+1}) \quad (90)$$

3 Stability of Numerical Integration and Numerical Differentiation Methods

3.0 Introduction

The stability criteria for the three numerical integration methods and for the numerical differentiation method used in the step-by-step response analysis of the SDOF systems analyzed in this study are given in this chapter. Recall that the numerical integration methods included in this study are (a) the linear acceleration method of the Newmark β family of numerical methods, (b) the Wilson θ method, and (c) the 4th Order Runge-Kutta method. The numerical differentiation method used is the Central Difference Method. The stability criterion for each of these four algorithms is established by the values assigned to the constants that are used in the algorithm and the terms associated with the structural model.

The stability condition requirements for numerical methods are categorized as either unconditional or conditional. A numerical method is unconditionally stable if the numerical solution for any initial value problem does not artificially grow without bound for any time-step Δt , especially if the time-step is large (Bathe and Wilson 1976; Bathe 1982; Hughes and Belytshko 1983; Hughes 1987; and Chopra 1995). The method is conditionally stable if the previous statement is true only for those cases in which the time-step Δt is less than some critical time-step $\Delta t_{critical}$. Figure 5 shows the attributes of a stable response, computed using $\Delta t < \Delta t_{critical}$, and the attributes of an unstable response, computed using $\Delta t > \Delta t_{critical}$ for the same *undamped* SDOF system in *free vibration*.

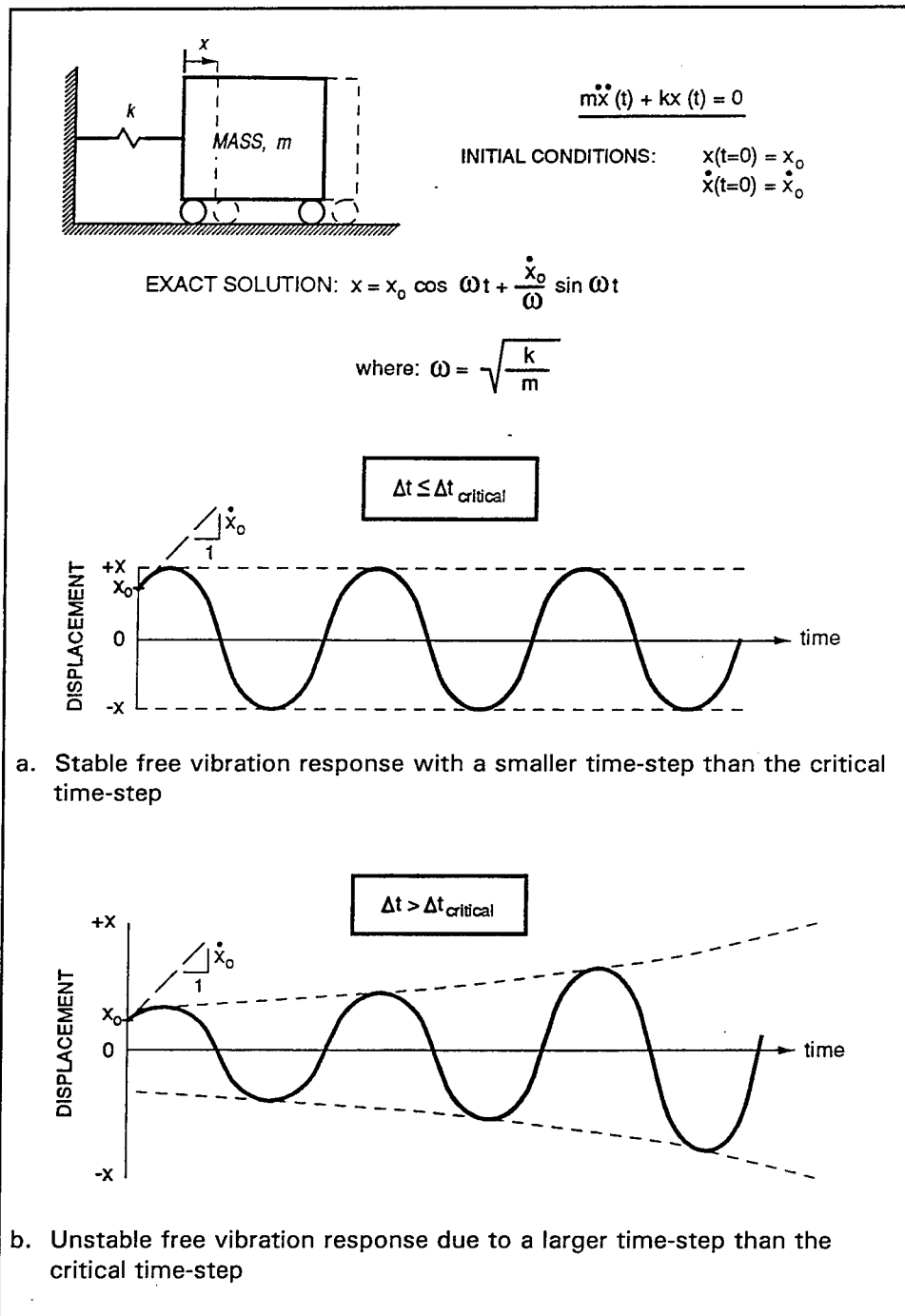

Figure 5. Example of response for an undamped SDOF system in free vibration (Ebeling 1992)

3.1 Stability Criteria for Two Implicit Numerical Integration Methods

The linear acceleration method of the Newmark β family of numerical methods is conditionally stable. The critical time-step is defined as

$$\Delta t_{critical} = \frac{1}{\pi \sqrt{2}} \frac{1}{\sqrt{\gamma - 2\beta}} T_o \quad (91)$$

and recall that T_o equals the natural (undamped) period of the SDOF system (Hughes and Belytshko 1983; Hughes 1987; Subbaraj and Dokainish 1989b; and Chopra 1995). With γ equal to 1/2 and β equal to 1/6 for the linear acceleration method, $\Delta t_{critical}$ becomes

$$\Delta t_{critical} = 0.551 T_o \quad (92)$$

Thus, the stability criterion for a SDOF system dictates that

$$\Delta t \leq \Delta t_{critical} \quad (93)$$

Equation 92 indicates that when the linear acceleration method is applied to the response analysis of SDOF systems for either free vibration or forced vibration analysis, the analysis requires *two time-steps per natural vibration period* of the structure to satisfy stability criteria. For the case of T_o equal to 0.5 sec, $\Delta t_{critical}$ becomes 0.276 sec, and with T_o equal to 0.25 sec, $\Delta t_{critical}$ reduces to 0.138 sec. Since all SDOF systems used in this study are assigned T_o equal to 0.5 sec or 0.25 sec and are subjected to ground motion with Δt set equal to either 0.02, 0.01, or 0.005 sec, it is concluded that the numerical computations using the linear acceleration method are stable. The results of these forced vibration analyses will be discussed in Chapter 4.

The Wilson θ method is unconditionally stable when the value assigned to the constant θ is greater than 1.366. A value of θ equal to 1.38 is used in this study. Thus, no restraints (such as a $\Delta t_{critical}$ value) are placed on the time-step Δt used in the analyses from the viewpoint of numerical stability considerations.

3.2 Stability Criteria for an Explicit Numerical Integration Method

The 4th Order Runge-Kutta method is an unconditionally stable explicit numerical integration method (Thomson 1993 or Subbaraj and Dokainish 1989b). Therefore, no restraints (such as a $\Delta t_{critical}$ value) are placed on time-step Δt used in the analyses from the viewpoint of numerical stability considerations.

3.3 Stability Criteria for a Numerical Differentiation Method

The Central Difference Method is a conditionally stable explicit numerical differentiation method. The critical time-step is defined as

$$\Delta t_{critical} = \frac{1}{\pi} T_o \quad (94)$$

(Bathe and Wilson 1976; Bathe 1982; Hughes and Belytshko 1983; Hughes 1987; Subbaraj and Dokainish 1989b; Clough and Penzien 1993; and Chopra 1995). Equation 94 indicates that when the Central Difference Method is applied to the response analysis of SDOF systems for either free vibration or forced vibration analysis, the analysis requires *three time-steps per natural vibration period* of the structure to satisfy stability criteria. For the case of T_o equal to 0.5 sec, $\Delta t_{critical}$ becomes 0.159 sec, and with T_o equal to 0.25 sec, $\Delta t_{critical}$ reduces to 0.08 sec. Since the SDOF systems used in this study (with T_o equal to 0.5 sec or 0.25 sec) are subjected to ground motion with Δt set equal to either 0.02, 0.01, or 0.005 sec, it is concluded that the numerical computations using the Central Difference Method are stable.

3.3.1 MDOF systems

Stability conditions must be satisfied for each mode in the MDOF system model, even if the response in the higher modes is insignificant (Hughes 1987, page 493; or Chopra 1995, page 575). Accordingly, stability criteria, expressed in terms of the limiting time-step $\Delta t_{critical}$ for conditionally stable algorithms, are more restrictive for MDOF systems than for SDOF systems. Hughes (1987, pages 540-542) shows a numerical exercise to establish the time-step Δt value to be used in a "transient analysis of an undamped multidegree-of-freedom structure ... for which engineering insight reveals that the response will be primarily in the first six modes. Engineering accuracy dictates that relative period error and amplitude decay (per cycle) be no more than 5 percent for any of the first six modes." (A discussion of the issues related to the accuracy of the numerical step-by-step procedures is postponed until Chapter 4.) However, this example shows

that the time-step needed to satisfy the stability requirement of the Central Difference Method is so small that there is no need to worry about accuracy criteria. This is because the maximum time-step is computed using Equation 94 with T_o replaced by the minimum period (i.e., the maximum frequency) of either the modes for the MDOF model or the individual elements modeling the structure (depending on the formulation used to solve the equation of motion of the MDOF system model). The maximum time-step allowed for several unconditionally stable, numerical step-by-step procedures that may be used for the response analysis are also computed in this exercise. The results of Hughes' example highlights the fact that unconditionally stable algorithms need be concerned only with the issue of accuracy, and a significantly larger time-step Δt may be used in the MDOF system response analysis being considered, compared to $\Delta t_{critical}$ for the Central Difference Method. Lastly, Chopra (1995, page 170) observes that in the analysis of semidiscrete MDOF system models it is often necessary to use unconditionally stable methods. Hughes (1987, page 536) notes that the use of unconditionally stable methods is particularly important in complicated structural models containing slender members exhibiting bending effects.

3.4 Conclusions

In summary, the following conclusions are made regarding the stability requirements of the numerical methods used in this study:

- a. The Wilson θ method with θ equal to 1.38 and the 4th Order Runge-Kutta method are unconditionally stable with no requirements made on the time-step Δt used in the analyses.
- b. The linear acceleration method, of the Newmark β family, and the Central Difference Method are conditionally stable. However, since the SDOF systems used in this research are subjected to ground motion with Δt set equal to either 0.02, 0.01, or 0.005 sec, it is concluded that the computations using these two numerical methods are stable.

Additionally, the following observation is made: in most earthquake engineering/dynamic structural response analyses, a time-step Δt equal to either 0.02, 0.01, or 0.005 sec is commonly used to define the ground motion acceleration time-history. In general, stability will not be an issue for the computed results when either the linear acceleration method or the Central Difference Method is used for SDOF systems with T_o ranging from 0.25 to 0.5 sec. The time-step Δt used to accurately define the ground motion will be much smaller than the $\Delta t_{critical}$ value for either of these numerical methods. The accuracy of six numerical step-by-step procedures will be discussed in detail in Chapter 4.

4 Accuracy of Six Numerical Step-by-Step Procedures of Analysis of the Equation of Motion for SDOF Systems

4.0 Introduction

In general, the accuracy of a numerical algorithm is associated with the rate of convergence of the computed response with the exact response as $\Delta t \rightarrow 0$ (Hughes 1987). The six algorithms included in this study are the Newmark β method (with values of constants γ and β corresponding to the linear acceleration method), the Wilson θ method, the Central Difference Method, the 4th Order Runge-Kutta method, Duhamel's integral solved in a piecewise exact fashion, and the Piecewise Exact Method applied directly. Specific details regarding the equations used in each of the six numerical step-by-step procedures are given in Chapter 2.

Much of the *current guidance* for selecting the time-step Δt used in computing the dynamic response of SDOF and MDOF models to ground motion is based on studies of the accuracy of numerical methods for computing *free vibration* response of undamped SDOF systems. The information from the free vibration studies is often combined with useful but *qualitative* reference to the frequency characteristics of the forcing function. The time-step Δt criterion is often expressed as a fraction of the natural (undamped) period of the SDOF system for a specified level of accuracy. Section 4.1 gives a brief review of published numerical assessments of the accuracy of several numerical algorithms for different time-step Δt values used to compute the free vibration response of undamped SDOF models. Current guidance on the factors to be considered when choosing the value of Δt to be used in response analysis of structures to earthquake shaking is also included.

Using *damped* SDOF system models with natural periods assigned based on consideration of the important modal periods of hydraulic structures, an evaluation

is made in this study of the accuracy of the computed response values solved for at regular time increments during ground motion. Recall from Section 2.1 that a ground acceleration applied at the base of an SDOF system is equivalent to a fixed-base SDOF system with the forcing function applied directly to the mass. Section 4.2 summarizes the results from an extensive series of numerical computations used to evaluate the accuracy of the six numerical step-by-step procedures used in this study. Time-step Δt values of 0.02, 0.01, and 0.005 sec are used in the response analysis of SDOF systems subjected to base accelerations with different frequency characteristics. The dynamic response for each damped SDOF structural model used in this study ($\beta = 0.05$) is characterized by the computed response time-histories of accelerations, velocities, and displacements. These results, combined with computations made using closed form solutions, allow for the development of *quantitative* guidance as to how the *accuracy* of the six numerical step-by-step procedures is affected by both the *time-step* Δt and the *frequency characteristics of the ground motion*.

4.1 Error in Free Vibration Response of SDOF Systems

The accuracy of a numerical step-by-step procedure is usually characterized using the computed results from *free vibration* response analyses of undamped SDOF systems compared with the results from a closed form (exact) solution to the equation of motion. This section briefly reviews select results from a commonly cited numerical assessment of the accuracy of numerical algorithms for different time-step Δt values used to compute the dynamic response of SDOF structural models in *free vibration*. The figures used to quantify the accuracy of numerical step-by-step procedures and the application example cited are taken from Hughes (1987).

Error is inherent in any numerical solution of the equation of motion (Chopra 1995, page 170). A common method used to gain insight into the magnitude of error for a numerical step-by-step procedure is to quantify the difference in computed displacements with the exact displacements for an undamped SDOF system in free vibration. The undamped SDOF system is set in motion by an initial displacement x_o and an initial velocity \dot{x}_o at time $t = 0$ sec. The exact solution for displacement x of the undamped SDOF system with time t for this boundary value problem is given in Figure 5. This equation for x is obtained using standard solution procedures for linear differential equations, such as the method of undetermined coefficients (e.g., Section 2.12 in Kreyszig 1972). The response described by this equation and shown in Figure 5a is cyclic with a constant maximum amplitude

$$|x(t)|_{\max} = \sqrt{x_o^2 + \left(\frac{\dot{x}_o}{\omega}\right)^2} \quad (95)$$

and constant circular frequency ω ($(k/m)^{1/2}$ radian). Recall from basic structural dynamics that an undamped SDOF system responds at its natural (undamped) period T_o , equal to $2\pi/\omega$ sec (Ebeling 1992). Thus the response is said to be periodic with each complete response cycle occurring over a constant interval in time equal to T_o sec. These attributes of a periodic response and the same maximum displacement amplitude in each cycle facilitate the assessment of the error in the displacements computed using a numerical step-by-step procedure of analysis.

Figure 6 (Hughes 1987) summarizes the results of error assessments made using several different numerical step-by-step procedures to solve for the displacement x of undamped SDOF systems in *free vibration* for a wide range in time-step Δt values. The abscissa of Figures 6a and 6b is the ratio of Δt divided by T_o , the natural (undamped) period of the SDOF system. Two definitions of error are possible for the free vibration problem: (a) amplitude decay, designated as *AD*, and (b) period elongation, designated as *PE*. These two types of errors are shown in the idealized schematic in the center, upper diagram in Figure 6 for one complete cycle of displacement x . Since the SDOF system is undamped, any amplitude decay *AD* in displacement x (per cycle) computed using a numerical step-by-step procedure will be a measure of the error in computed response. This error measurement is sometimes reported as “algorithmic damping” since the actual response for the SDOF system is undamped with no amplitude decay per cycle. Amplitude decay is converted to algorithmic damping using the equation given in the center, upper schematic. The second type of error possible is referred to as period elongation and measures the extension in the time increment it takes to complete each cycle of harmonic response.

The data in Figure 6 show that for the free vibration problem of an SDOF system with a constant natural period T_o , the magnitude of one or both error measurements usually increases with the time-step Δt . (Refer to Hughes (1987, Section 9.3) for details regarding the numerical step-by-step procedures identified in this figure.) Conversely, Figure 6 shows that for a specified time-step Δt , the magnitude of one or both error measurements is greater for short-period SDOF systems than for long-period SDOF systems. In summary, this figure shows the errors associated with a given numerical procedure to be a function of (a) the time-step Δt used in the analysis and (b) the natural (undamped) period T_o . Similar error plots are given in Chopra (1995, Figure 5.5.2 on page 173) and in Bathe and Wilson (1976, Figure 9.3 on page 357).

4.1.1 MDOF systems

The data given in Figure 6 may also be used to establish the largest time-step Δt for a specified level of accuracy in response analysis of semidiscrete MDOF system models. Hughes (1987, pages 540-542) gives a numerical exercise to establish the time-step Δt value to be used in a “transient analysis of an undamped multidegree-of-freedom structure ... for which engineering insight reveals that the

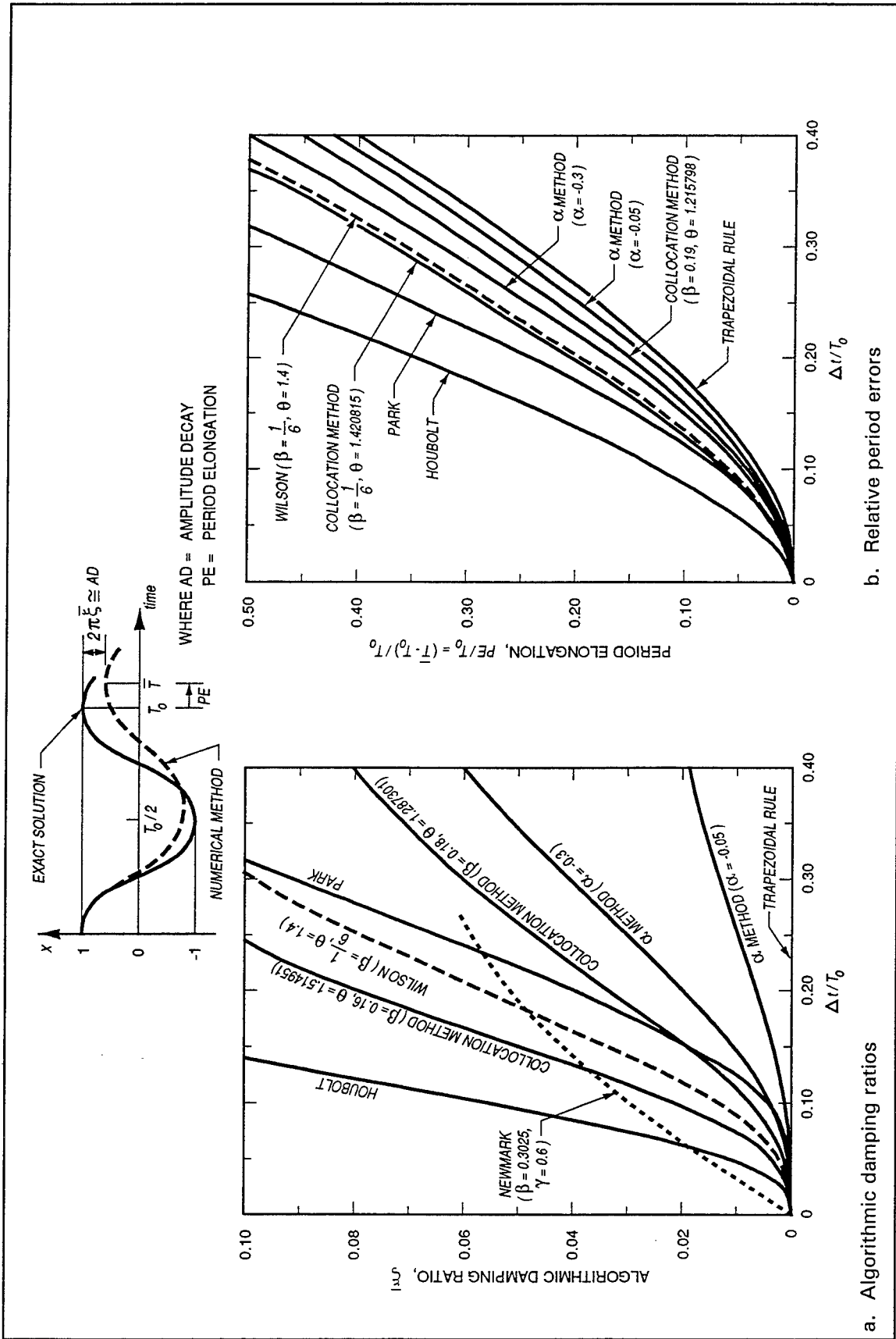

Figure 6. Errors in free vibration response of SDOF systems for α -methods, optimal collocation schemes, and Houbolt, Newmark, Park, and Wilson methods (Courtesy of Hughes 1987)

response will be primarily in the first six modes. Engineering accuracy dictates that relative period error and amplitude decay (per cycle) be no more than 5 percent for any of the first six modes.” The corresponding value of algorithmic damping ratio is computed to be $0.05/2\pi$, equal to 0.008. This exercise uses the Figure 6 data to establish the Δt values to be used in each of the numerical step-by-step procedures identified in this figure. From modal analysis of the MDOF system, it is established that the natural period for the sixth mode, T_6 , is equal to one-tenth (1/10) the natural period of the first mode, T_1 (thus, $T_1 = 10T_6$). Hughes’ exercise shows that when unconditionally stable algorithms, such as the Wilson θ method, are used to compute the response of MDOF system models, the 5 percent error criterion for amplitude decay AD and period elongation PE establishes two limiting values for the ratio ($\Delta t/T_6$). For this example, Figure 6 shows that both limiting values of the ratio ($\Delta t/T_6$) are equal to 0.08. Note that because this is an MDOF system problem, the natural period T_1 in the denominator of the abscissa of Figures 6a and 6b is replaced by T_6 , the highest frequency of engineering significance contributing to system response in this analysis. Thus the value of the largest time-step Δt that can be used in the response analysis using the Wilson θ method is equal to $0.08T_6$ ($0.008T_1$). Additionally, if the time-step criteria for AD and PE differ, the smallest value for the ratio ($\Delta t/T_6$) is used to establish the largest time-step Δt since the 5 percent maximum error criteria must be satisfied in terms of both AD and PE .

4.1.2 Current guidance for assigning the time-step Δt to be used in earthquake engineering dynamic structural response analysis

Much of the *current guidance* for selecting the time-step Δt used in computing the dynamic response of SDOF and MDOF models to ground motion makes use of Figure 6 type data from *free vibration* response analyses of undamped SDOF systems. This information is often combined with useful but *qualitative* reference to the frequency characteristics of the forcing function. For example, after going through an exercise of evaluating the accuracy of numerical algorithms, Chopra (1995, pages 172 and 568) concluded that his Figure 5.5.2 data (comparable to the Figure 6 data) suggest that a time-step Δt equal to $0.1T_N$ would give reasonably accurate results. (T_N is the natural period in seconds of the N th mode of the MDOF system model *with significant response contribution*.) This same guidance is also given by Bathe and Wilson (1976, pages 351-352), Clough and Penzien (1993, pages 128-129), and Paz (1991, page 155), with the caveat of when “the loading history is simple.” Chopra (1995, pages 172-173) concludes his discussion of computational error with the observations that “... the time step should be short enough to keep the distortion of the excitation function to a minimum. A very fine time step is necessary to describe numerically the highly irregular earthquake ground acceleration recorded during earthquakes; typically, $\Delta t = 0.02$ seconds is chosen and this dictates a maximum time step for computing the response of a structure to earthquake excitation.” Gupta (1992, page 155) recommends that “the time step used in the response computations is selected as the smaller of the digitized interval of the earthquake accelerogram or some fraction of the period of free vibration, for example $T/10$.”

In summary, Paz (1991, page 155), Gupta (1992, page 155), Clough and Penzien (1993, pages 128-129), and Chopra (1995, pages 172-173) all recognize that the assignment of time-step Δt in response analysis to forced vibration should consider the following factors: (a) the natural period of the structure; (b) the rate of variation of the loading function; and (c) the complexity of the stiffness and damping functions. However, no error summary similar to Figure 6 for the forced vibration of damped SDOF systems in which ground motion is represented by an acceleration time-history is given in the books on structural dynamics by Bathe and Wilson (1976), Hughes (1987), Paz (1991), Gupta (1992), Clough and Penzien (1993), and Chopra (1995).

4.2 Error in Response of SDOF Systems to Ground Motion

This section summarizes the results of an assessment of the accuracy of response of six numerical step-by-step procedures used in computational structural dynamics. The six algorithms used in this study are representative of the different types of numerical procedures used to compute the dynamic structural response to a time-dependent loading. The time-dependent loading envisioned in this research is that of the *motion of the ground* below a discrete structural model and is expressed in terms of a ground acceleration time-history. The dynamic structural response for each structural model used in this study is characterized by the computed response time-histories of accelerations, velocities, and displacements.

The six algorithms included in this study are the Newmark β method (with values of constants γ and β corresponding to the linear acceleration method), the Wilson θ method, the Central Difference Method, the 4th Order Runge-Kutta method, Duhamel's integral solved in a piecewise exact fashion, and the Piecewise Exact Method applied directly. Specific details regarding the equations used in each of these numerical step-by-step procedures are given in Chapter 2. Recall from Section 2.1 that a ground acceleration applied at the base of a SDOF system is equivalent to a fixed-base SDOF system with the forcing function applied directly to the mass.

These numerical results, combined with computations made using closed form solutions, allow for the development of *quantitative* guidance as to how the *accuracy* of the six numerical step-by-step procedures are affected by both the *time-step* Δt and the *frequency characteristics of the ground motion*.

4.2.1 SDOF systems

All structural models used in this numerical study are linear, SDOF systems with a damping ratio set equal to 5 percent ($\beta = 0.05$). Two SDOF systems are used in this numerical study: $T_o = 0.25$ sec (frequency $f_o = 4$ Hz) and $T_o = 0.5$ sec

($f_o = 2$ Hz). Recall from structural dynamics that frequency f_o (cycles/sec or Hz) is equal to the inverse of T_o (e.g., Ebeling 1992). The natural (undamped) periods and damping ratio of the SDOF systems used in this numerical study were based on dynamic response analyses procedures used to model and analyze various types of hydraulic structures, such as gravity dams, arch dams, gravity lock walls, U-frame locks, and intake towers. The shortest period (highest frequency) of engineering significance contributing to system response for these hydraulic structures was also taken into consideration when selecting the range in T_o values.

4.2.2 Time-step Δt

The time increments, Δt , used in this numerical study are 0.02, 0.01, and 0.005 sec. These values are typical of the Δt used in discretizing earthquake acceleration time-histories recorded in the field on strong motion accelerographs (e.g., Hudson 1979).

4.2.3 Ground motion

The ground motion forcing functions used in this numerical study are single-frequency harmonics. The use of a single frequency facilitated the evaluation of the accuracy of the computed response values solved for at regular time increments during ground motion. Figure 7 shows the three ground acceleration time-histories used. All three ground motions contain twenty cycles of sinusoidal acceleration with peak ground acceleration of 1 g. The three acceleration time-histories are distinguished from one another by the time interval required to complete *each cycle* of sinusoidal acceleration, designated as T_g . The values of T_g are 0.05, 0.25, and 1.0 sec. Accordingly, the corresponding durations of ground motion are 1, 5, and 20 sec, respectively.

The three ground motions shown in Figure 7, with T_g equal to 0.05, 0.25, and 1 sec, possess cyclic frequencies f_g of 20 Hz, 4 Hz and 1 Hz, respectively. These frequencies are often contained within acceleration time-histories that have been recorded in the field on strong motion accelerographs during numerous earthquakes and are often encountered in earthquake engineering dynamic response analysis of structures. It has also been the experience of the authors to encounter this range of frequencies in the earthquake engineering dynamic structural response analysis of hydraulic structures.

4.2.4 Frequency of ground motion relative to frequency of SDOF systems

Basic structural dynamics demonstrates that the magnitude of the frequency f_g , or, equivalently, period T_g , of the forcing function relative to the magnitude of the natural frequency f_o , or period T_o , of the SDOF system impacts the magnitude of dynamic structural response. A response spectrum is a convenient plot for

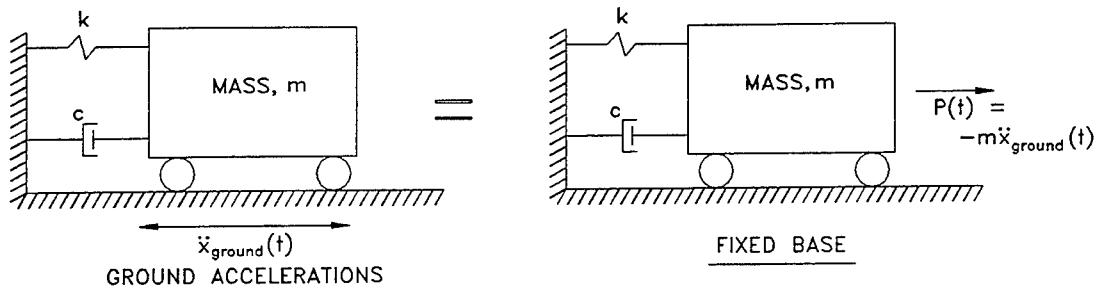

with

$$\ddot{x}_{ground}(t) = A_{max} * \sin\left(\frac{2\pi t}{T_g}\right)$$

and

$$A_{max} = 1g$$

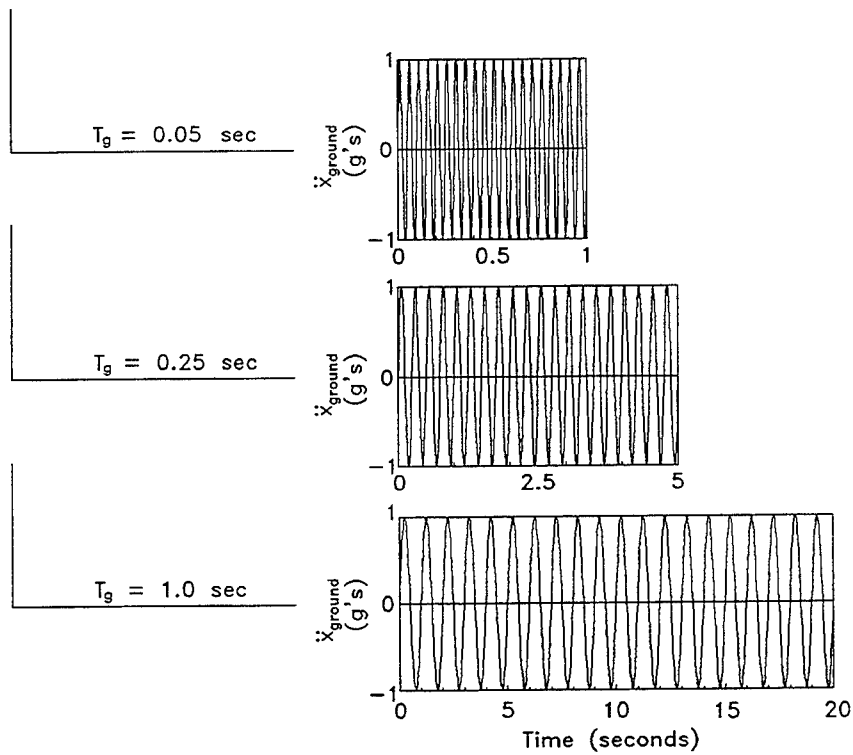

STEP 1. SOLVE

$$m\ddot{x}_{ground}(t) + c\dot{x}(t) + kx(t) = -m\ddot{x}_{ground}(t)$$

STEP 2. SOLVE

$$\ddot{x}_{total}(t) = \ddot{x}(t) + \ddot{x}_{ground}(t)$$

Figure 7. Equivalent dynamic SDOF system problems

characterizing these interrelationships (Ebeling 1992). The response spectra shown in Figure 8, with $\beta = 0.05$, shows the relationship of the frequency content for each of the three acceleration time-histories *relative* to the natural frequency of the two SDOF systems. The three ground motions used in this study possess frequencies that are larger, equal to, and less than the natural frequency of the two SDOF systems. Thus, three important combinations for the frequency content of the ground motion relative to the natural frequency of the SDOF system are included in this investigation. SDOF system responses, plotted in Figure 8 in terms of pseudo-acceleration S_A normalized by the peak ground acceleration A_{\max} of 1 g, demonstrate that the frequency content for the three ground motions shown in Figure 7 are sufficiently close to the natural frequencies to excite the SDOF systems and thus induce a dynamic response. (Refer to Table 2 in Ebeling 1992 for the definition of S_A and for additional details regarding response spectra.)

4.2.5 Time-histories of 432 step-by-step response analyses

The dynamic response for each SDOF model used in this study was characterized by the computed response time-histories of relative displacements, relative velocities, relative accelerations, and total accelerations. With three time-steps ($\Delta t = 0.02, 0.01$ and 0.005 sec) three ground motions ($T_g = 0.05, 0.25$ and 1 sec), a total of 432 response time-histories were computed for the two damped SDOF systems using the six numerical step-by-step procedures. Additionally, the exact response quantities were generated for each SDOF system for each time-step and each ground motion using the closed form solution given in Appendix A. All calculations were made using two computer programs developed for use in this study. Each of the computed response time-histories was stored on disc in 432 separate files. Each file contained up to 4,000 response values (and corresponding time t values), depending on the time-step Δt value used in the analysis and the duration of the ground motion used to excite the damped SDOF system.

4.2.6 Results from 12 of the 432 error studies

In this numerical study, the key variables thought to impact the accuracy of the results of the six numerical step-by-step procedures were (a) the time-step Δt , (b) the frequency content of the ground motion (characterized by T_g), (c) the value of T_g relative to the value of T_o , and (d) the natural period T_o of the SDOF system. The evaluation of the 432 response time-histories started with a comparison with their corresponding exact solution. These initial 432 comparison plots helped to identify which variables contribute to the inaccuracy in computed results and the extent of their contribution. Only 12 of these 432 comparison figures are included in this report due to space limitations. However, the time-histories that are included in this report, and discussed in the following paragraphs, demonstrate how information was extracted and used in this extensive numerical study.

Figures 9, 10, and 11 each show the four response time-histories of an SDOF system with T_o equal to 0.25 sec and β equal to 0.05. These response

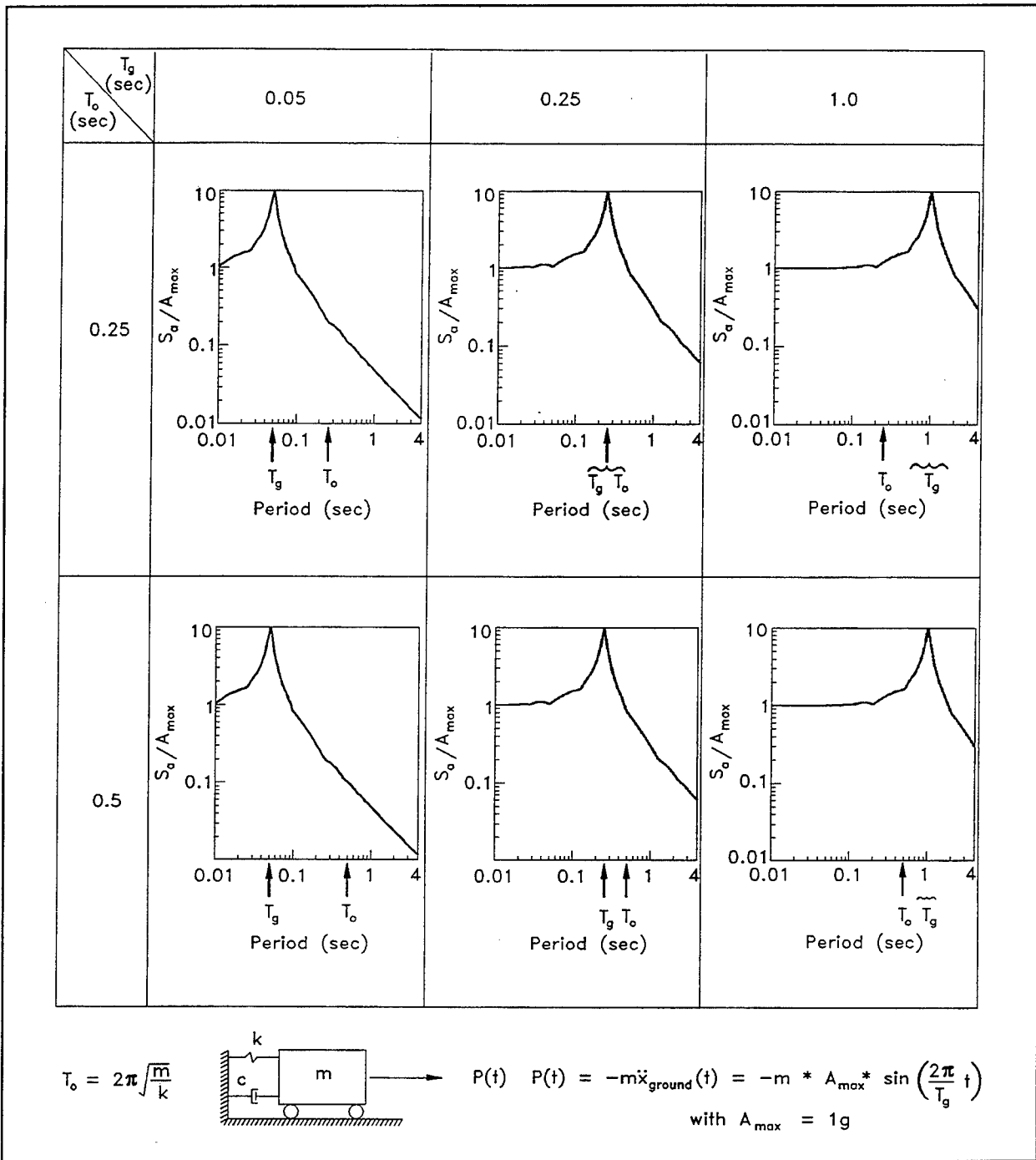

Figure 8. Response spectra of two SDOF systems with 5 percent damping for three harmonic forcing functions

time-histories were computed using both the Wilson θ method ($\theta = 1.38$ and a time-step Δt equal to 0.01 sec) and the exact solution (Appendix A). The response analyses differ among the three figures by the frequency assigned to the ground motion, with T_g set equal to 0.05 sec (20 Hz), 0.25 sec (4 Hz), and 1 sec (1 Hz),

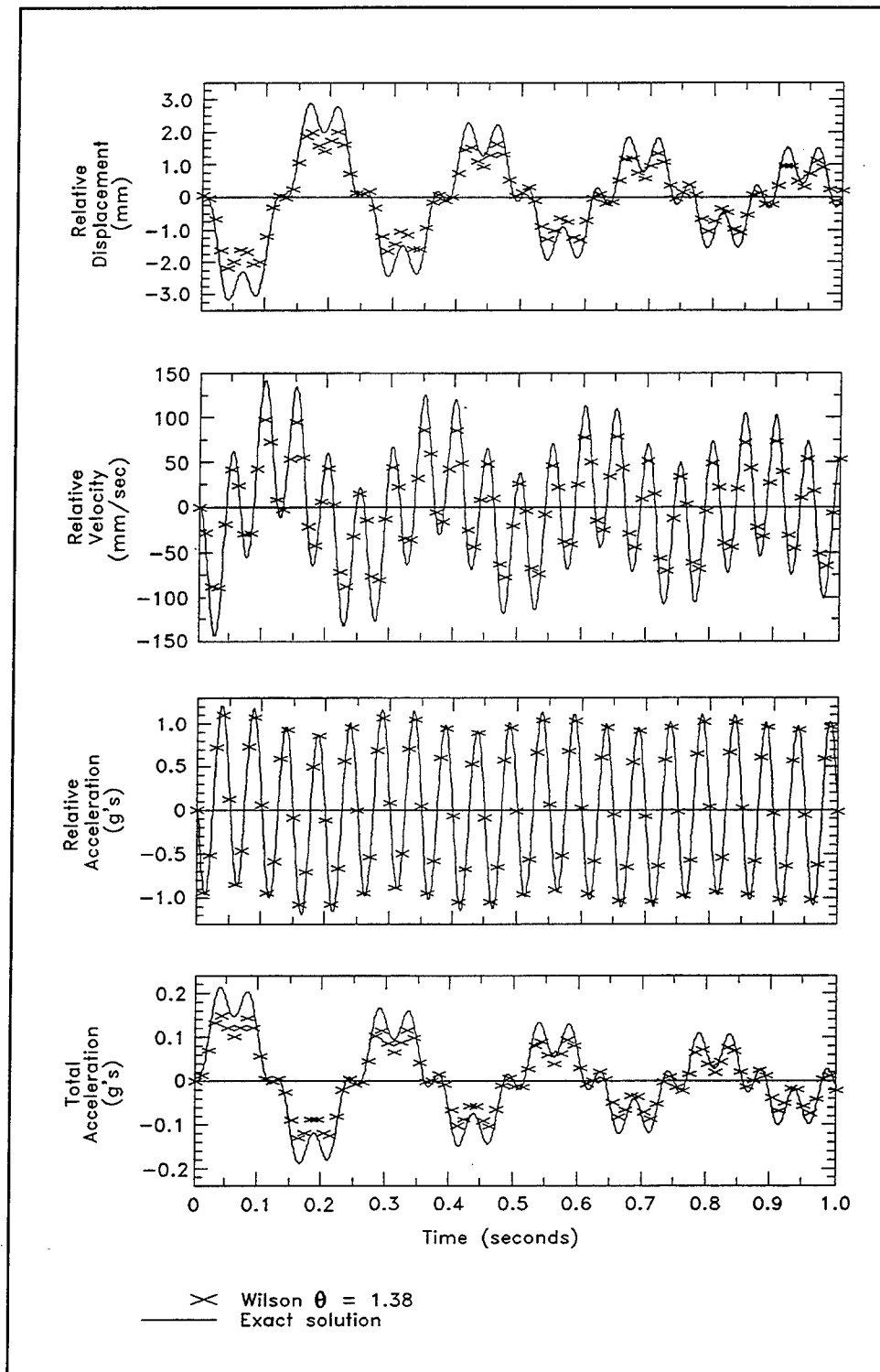

Figure 9. SDOF system ($T_o = 0.25$ sec) response time-histories ($\Delta t = 0.01$ sec) computed using Wilson $\theta = 1.38$ for a sinusoidal forcing function of period $T_g = 0.05$ sec

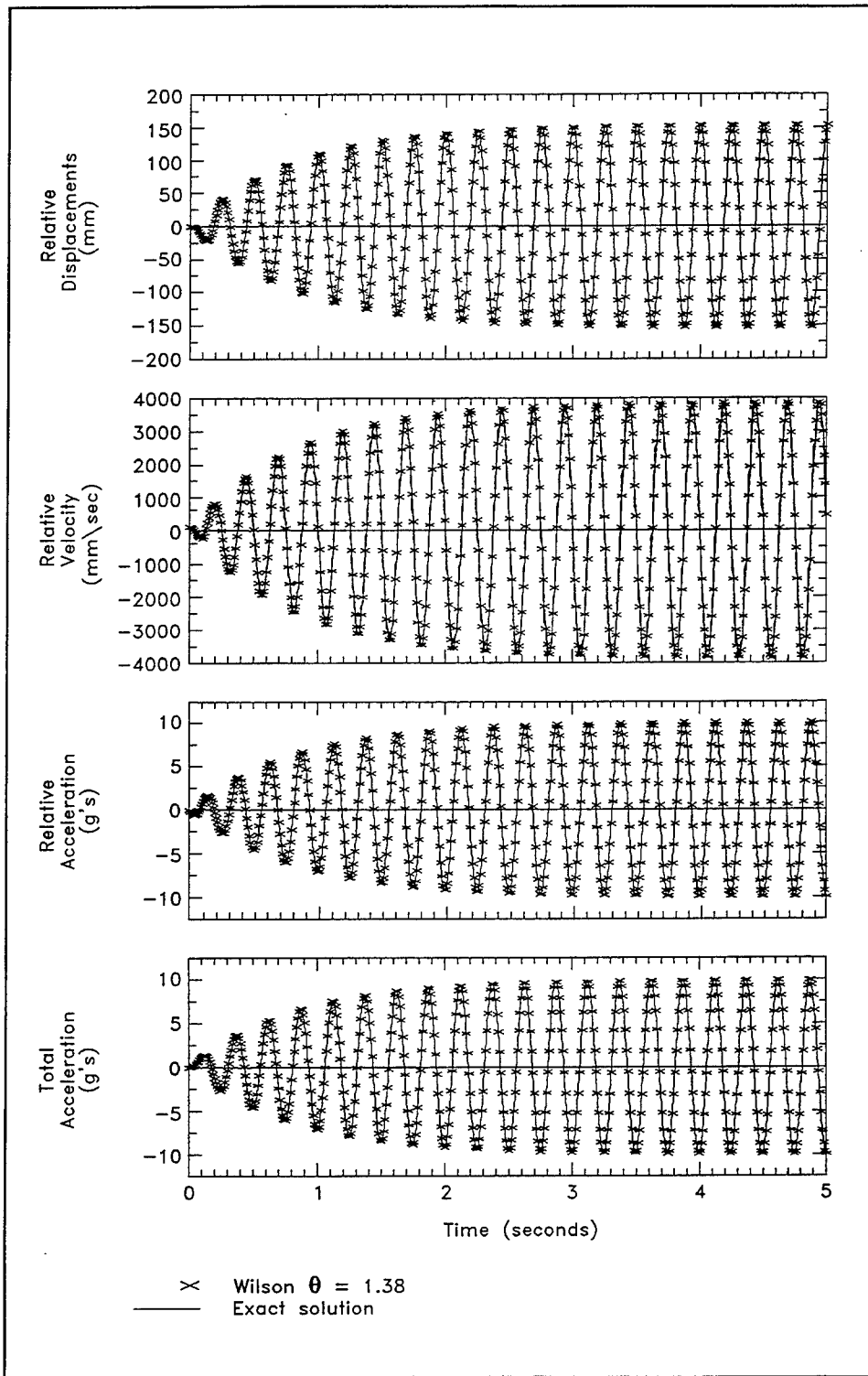

Figure 10. SDOF system ($T_o = 0.25$ sec) response time-histories ($\Delta t = 0.01$ sec) computed using Wilson $\theta = 1.38$ for a sinusoidal forcing function of period $T_g = 0.25$ sec

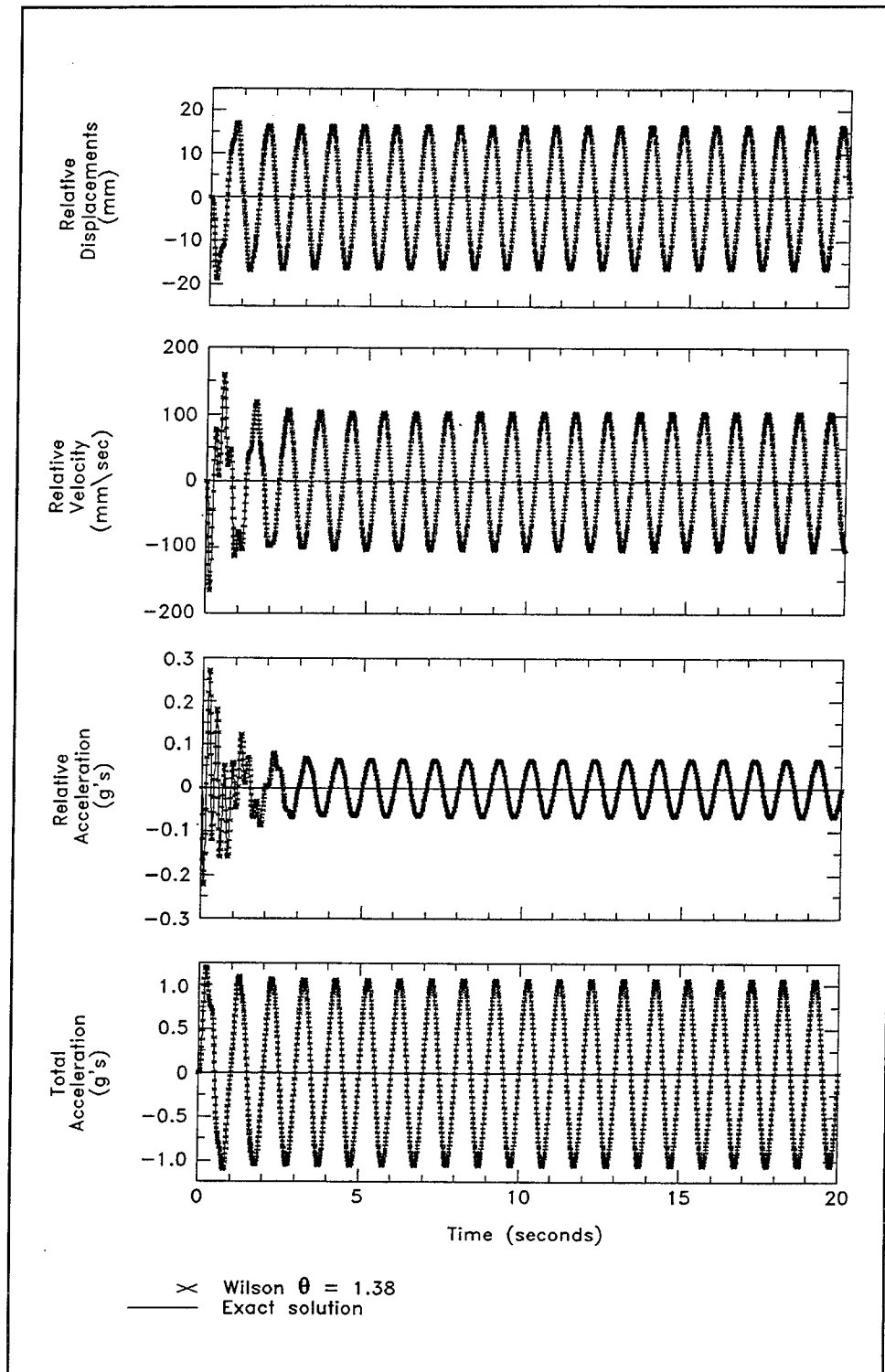

Figure 11. SDOF system ($T_o = 0.25$ sec) response time-histories ($\Delta t = 0.01$ sec) computed using Wilson $\theta = 1.38$ for a sinusoidal forcing function of period $T_g = 1.00$ sec

respectively. Visual comparison of the computed results for each response quantity in the three figures shows a dramatic variation in SDOF response. The rise in amplitude and frequency of wave form for the plots of relative displacement shows the most dramatic variation. Recall that these SDOF system responses are all driven by sinusoidal ground motions with 1-g maximum amplitude (Figure 7). This dramatic variation in response demonstrates the impact that the frequency content for the ground motion relative to the natural frequency of the SDOF system has on the dynamic response. These results also demonstrate the diversity of the numerical tests being conducted, even though the forcing functions shown in Figure 7 bear a strong resemblance to one another.

Further visual examination of Figures 9, 10, and 11 shows a larger error in Figure 9 than in the other two figures. Since the frequency of the ground motion is varied among the three groups of response analyses shown in Figures 9, 10, and 11, the authors conclude that the frequency content of the ground motion affects the accuracy of all four response parameters when using the Wilson θ method. A more detailed examination of the results in Figure 9 shows that the accuracy differs among the four response quantities. For example, the relative acceleration response data are more accurate than the relative velocity response data.

Because these results are all computed using forced vibration analyses of damped SDOF systems, the definitions of numerical errors used in free vibration response analysis of undamped SDOF systems (and described in Section 4.1) are not appropriate. A new definition of numerical error in the computed response data is needed. Recognizing that the results from time-history analysis of linear structural systems subjected to earthquake excitation are usually concerned with the extreme values in computed results, an error definition is made accordingly (Figure 12). The upper plot in this figure is the same relative displacement time-history data shown in Figure 9. The time-history of 100 response values ($100 = \text{duration of ground motion}/\Delta t$) computed using the Wilson θ method and the response values computed using the exact method are searched numerically for "peaks and valleys." This is accomplished using a third computer program that searches through the response time-history data looking for a reverse in sign in a pair of slopes for three adjacent data points, with the first slope computed using a pair of response values at times $(t_i - \Delta t)$ and t_i and the next slope computed using response values at time t_i and $(t_i + \Delta t)$. The error in the computed response values, relative displacement in this figure, is then computed for each peak and each valley in the data. Lastly, only those peaks and valleys with significant amplitude, say greater than 10 percent of the absolute value of the largest response value, are recorded. An example error calculation is made for the first "peak" relative displacement response value and identified as such in the insert to the right in Figure 12. This insert shows that the first peak relative displacement value occurs at 0.06 sec, while the first peak computed using the exact solution occurs at 0.064 sec. The difference in time for the two peaks attests to the high frequency of the response compared to coarse time-step used in this Wilson θ method response analysis (i.e., $\Delta t = 0.01$ sec). The computed error is approximately 29 percent. This error point and 23 others are plotted versus time of occurrence (0.06 sec for the first peak) in the figure located immediately below the relative displacement

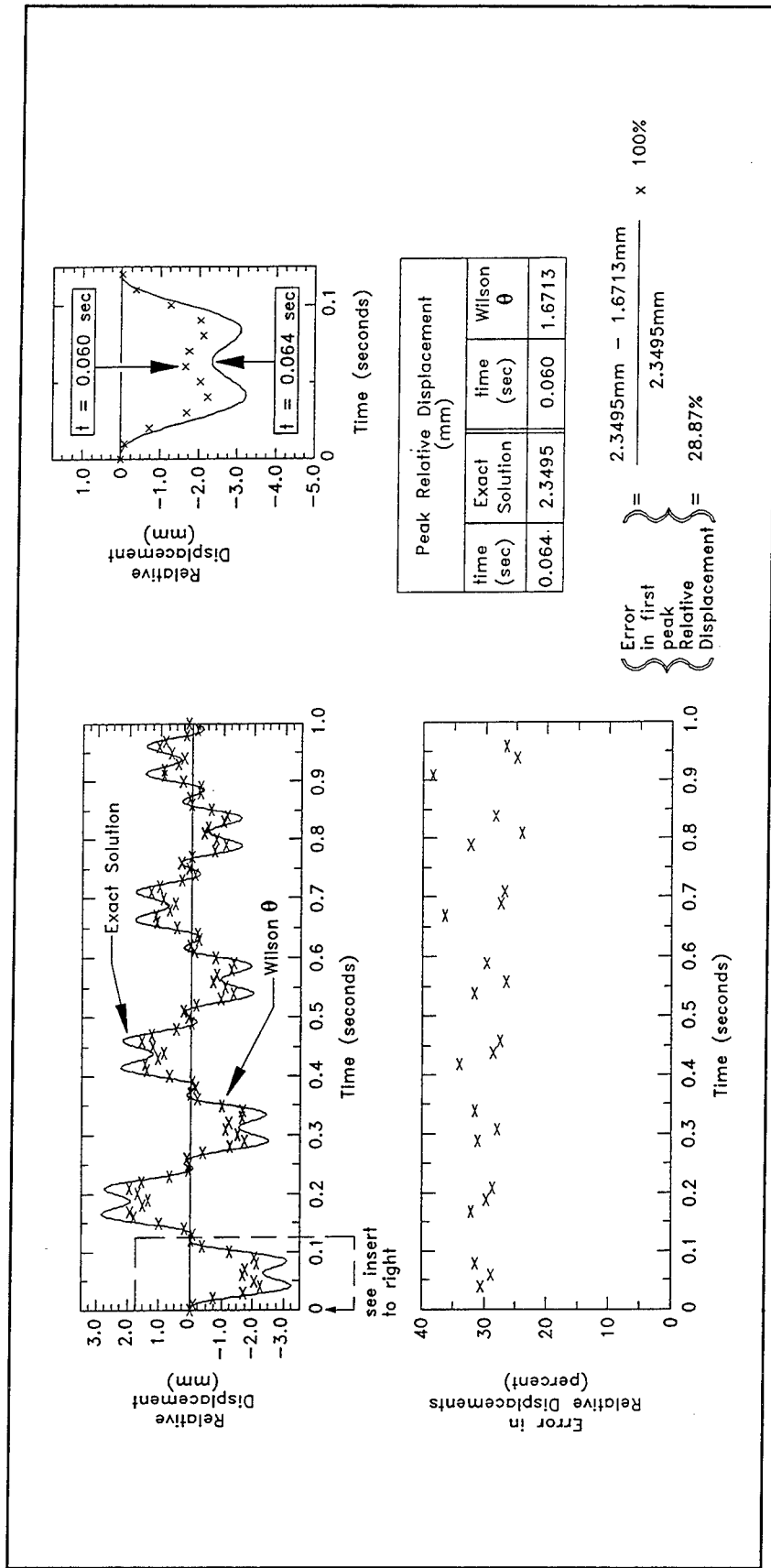

Figure 12. Error in relative displacements computed using Wilson $\theta = 1.38$ for an SDOF system ($T_g = 0.25$ sec) with a sinusoidal forcing function of period $T_g = 0.05$ sec and $\Delta t = 0.01$ sec

response time-history. This figure shows that the error in peaks and valleys of relative displacement ranges in value from a low of 24.1 percent to a high of 38.4 percent throughout the duration of shaking. The maximum relative displacement for the exact solution occurs at 0.042 sec and has a value of -3.225 mm. The maximum relative displacement computed by the Wilson θ method occurs at 0.04 sec and has a value of -2.239 mm. This corresponds to a 30.6 percent error in maximum response computed by the numerical procedure, occurring at the first "valley" in the response time-history (Figure 12).

4.2.7 Summary of numerical results from all 432 error studies

An error evaluation similar to that described in Section 4.2.6 was made for the remaining 431 response time-histories. These error evaluations were performed on all four response variables: relative displacement, relative velocity, relative acceleration, and total acceleration. The resulting 432 time-history error plots were reviewed by the authors. The range in error for all significant peaks and valleys of a given response parameter throughout the duration of shaking was tabulated, along with the error in the *maximum* response parameter value. The results of these extensive error evaluations are summarized in Tables 1 through 6 for relative displacement (designated Rel. D), relative velocity (Rel. V), relative acceleration (Rel. A), and total acceleration (Total A).

The six algorithms are designated in Tables 1 through 6 as follows: DHM for Duhamel's integral solved in a piecewise exact fashion; NMK for the Newmark β method with values of constants γ and β corresponding to the linear acceleration method; PWM for the Piecewise Exact Method applied directly; WIL for the Wilson θ method ($\theta = 1.38$); CDF for the Central Difference Method; and RGK for the 4th Order Runge-Kutta method. Each table shares a common value for the time-step Δt used in the numerical analyses. The coarsest time-step ($\Delta t = 0.02$ sec) is used in the numerical analyses reported in Tables 1 and 2. The intermediate time-step (0.01 sec) is used in the numerical analyses reported in Tables 3 and 4. The finest time-step (0.005 sec) is used in the numerical analyses reported in Tables 5 and 6. Each of the three ground motions shown in Figure 7 is distinguished in the tables by their T_g value (i.e. 0.05, 0.25, and 1 sec).

Table 1 summarizes the errors computed with Δt equal to 0.02 sec and T_g equal to 0.25 sec. The results are presented in three main groups and are distinguished by the ground motions used in the analyses. Recall that the frequency of the ground motion is reflected by the T_g value (and that the ground motion frequency $f_g = 1/T_g$).

The results given in Table 1 demonstrate that the accuracy of all six numerical algorithms depends on the frequency content of the ground motion, with all other variables held constant. The magnitudes of error for all four response parameters increase as the frequency of the ground motion increases. Using a time-step Δt equal to 0.02 sec for an SDOF system with T_g equal to 0.25 sec is acceptable for

Table 1
Percentile Errors in Relative Displacement (Rel. D), Relative Velocity (Rel. V),
Relative Acceleration (Rel. A), and Total Acceleration (Total A) for SDOF System of
 $T_o = 0.25$ sec and $\Delta t = 0.02$ sec

T_g , sec	$\frac{\Delta t}{T_g}$	Parameter	Error in Maximum Response (Range in Errors for Peak and Valley Values)					
			DHM	NMK	PWM	WIL	CDF	RGK
0.05	0.4	Rel. D	54 (50 to 79)	54 (52 to 66)	54 (50 to 66)	77 (70 to 81)	30 (40 to 90)	54 (53 to 65)
		Rel. V	61 (58 to 87)	62 (60 to 85)	61 (58 to 86)	64 (22 to 80)	100 (0 to 119)	61 (58 to 85)
		Rel. A	14 (3 to 45)	14 (2 to 44)	14 (2 to 45)	17 (15 to 46)	9 (1 to 41)	14 (2 to 43)
		Total A	54 (52 to 66)	55 (50 to 67)	54 (52 to 66)	72 (38 to 89)	25 (7 to 91)	55 (50 to 66)
0.25	0.08	Rel. D	5.3 (2.2 to 5.3)	2.2 (1.3 to 5.1)	5.3 (2.2 to 5.3)	9.9 (3.8 to 9.9)	1.9 (0.1 to 2.9)	5.4 (2.4 to 5.5)
		Rel. V	3.9 (2.2 to 4.3)	3.1 (1.6 to 4.7)	3.9 (2.2 to 4.3)	11.1 (4.5 to 11.1)	4.8 (1 to 4.8)	4.4 (2.2 to 4.4)
		Rel. A	5.1 (1.9 to 5.1)	0.2 (0 to 3.1)	2.9 (1.9 to 5.1)	5.6 (0.3 to 5.6)	3.1 (3.1 to 9)	5.1 (2 to 5.1)
		Total A	4.5 (2.1 to 4.6)	2 (1.3 to 4.2)	2.6 (2.1 to 5)	10.3 (3.9 to 10.3)	6.3 (4 to 7.5)	4.7 (2.2 to 5.1)
1.0	0.02	Rel. D	0	0	0	0	0	0
		Rel. V	0	0	0	0	0	0
		Rel. A	0	0	0	0	0	0
		Total A	0	0	0	0	0	0

Note: DHM = Duhamel's integral solved in a piecewise exact fashion.
 NMK = Newark β method.
 PWM = Piecewise Exact Method.
 WIL = Wilson θ method.
 CDF = Central Difference Method.
 RGK = 4th Order Runge-Kutta Method.

long-period ground motion ($T_g = 1$ sec, $f_g = 1$ Hz). However, for high-frequency ground motion ($T_g = 0.05$ sec, $f_g = 20$ Hz) a smaller Δt is required. The results given in Table 2 also support this same conclusion. Table 2 differs from Table 1 by the value of T_o used, increased from 0.25 sec to 0.5 sec.

Table 3 differs from Table 1 in the value of Δt used, reduced to 0.01 sec from 0.02 sec. These results show that the reduction in the time-step Δt to 0.01 sec remarkably improves the accuracy of all six numerical methods. However, inaccuracies are still present in the response values for all six procedures for the

Table 2
Percentile Errors in Relative Displacement (Rel. D), Relative Velocity (Rel. V),
Relative Acceleration (Rel. A), and Total Acceleration (Total A) for SDOF System of
 $T_o = 0.5$ sec and $\Delta t = 0.02$ sec

$T_{g'} / \text{sec}$	$\frac{\Delta t}{T_g}$	Parameter	Error in Maximum Response (Range in Errors for Peak and Valley Values)					
			DHM	NMK	PWM	WIL	CDF	RGK
0.05	0.4	Rel. D	57 (53.4 to 68.8)	57.1 (55.7 to 72.4)	57 (55.5 to 65.4)	77.3 (74.4 to 84.7)	46.5 (19.5 to 89.3)	57.1 (53.5 to 65.3)
		Rel. V	73.9 (59.1 to 81.8)	74.3 (59.4 to 93)	73.9 (59.2 to 93.5)	55.2 (2.2 to 104)	74 (45.4 to 130)	73.9 (59.2 to 93.5)
		Rel. A	9.7 (0.7 to 43)	9.7 (0.7 to 42.9)	9.7 (0.6 to 43)	11 (1.1 to 44.4)	8.3 (0.3 to 42.4)	9.7 (0.6 to 43)
		Total A	60.8 (50.8 to 70.7)	60.7 (51.7 to 74.4)	60.8 (50.8 to 70.7)	73.4 (60.5 to 91.6)	45.3 (16.4 to 77.1)	60.8 (50.8 to 64.8)
0.25	0.08	Rel. D	2.5 (2.1 to 7.7)	2.8 (0 to 7.0)	2.5 (2.2 to 7.7)	6.4 (4.1 to 25.5)	0.1 (0.1 to 9.2)	2.5 (2.1 to 7.4)
		Rel. V	2.9 (2.2 to 4.2)	3.5 (1.2 to 5.3)	2.9 (2.2 to 3.7)	7.6 (3.5 to 10.2)	2.2 (0.3 to 4.8)	2.9 (2.2 to 4.2)
		Rel. A	1.7 (0 to 3.5)	2.1 (0 to 3.8)	1.7 (0 to 3.4)	3.8 (0.2 to 5)	2.2 (0.4 to 4.3)	1.7 (0.2 to 3.5)
		Total A	2.2 (2 to 5.2)	2.4 (0.6 to 3.7)	2.2 (2.1 to 5.4)	5.9 (1.4 to 18.3)	4.4 (3.4 to 8.3)	2.2 (2 to 5.4)
1.0	0.02	Rel. D	0	0	0	0	0	0
		Rel. V	0	0	0	0	0	0
		Rel. A	0	0	0	0	0	0
		Total A	0	0	0	0	0	0

Note: DHM = Duhamel's integral solved in a piecewise exact fashion.
 NMK = Newark β method.
 PWM = Piecewise Exact Method.
 WIL = Wilson θ method.
 CDF = Central Difference Method.
 RGK = 4th Order Runge-Kutta Method.

high-frequency ground motion ($T_g = 0.05$ sec, $f_g = 20$ Hz). The results given in Table 4 also support this conclusion. Table 4 differs from Table 3 by the value of T_o used, increased from 0.25 sec to 0.5 sec.

Table 5 differs from Table 3 in the value of Δt used, reduced to 0.005 sec from 0.01 sec. These results show that a reduction in the time-step Δt to 0.005 sec eliminates all errors for the six numerical methods in all but the high-frequency ground motion compared with those given in Table 3. Small numerical inaccuracies are still present in the results for all six numerical step-by-step procedures for the high-frequency ground motion ($T_g = 0.05$ sec, $f_g = 20$ Hz). The results

Table 3
Percentile Errors in Relative Displacement (Rel. D), Relative Velocity (Rel. V),
Relative Acceleration (Rel. A), and Total Acceleration (Total A) for SDOF System of
 $T_o = 0.25$ sec and $\Delta t = 0.01$ sec

T_g , sec	$\frac{\Delta t}{T_g}$	Parameter	Error in Maximum Response (Range in Errors for Peak and Valley Values)					
			DHM	NMK	PWM	WIL	CDF	RGK
0.05	0.2	Rel. D	14.8 (5.3 to 18)	14.8 (5 to 20.8)	13.5 (6.2 to 19.1)	30.6 (24.1 to 38.4)	7.3 (7.3 to 21.6)	13.5 (12.7 to 18.8)
		Rel. V	13.7 (13.6 to 25.8)	19.6 (14.1 to 27.2)	19.1 (13.6 to 29.3)	37.5 (28.4 to 37.5)	18.8 (11.6 to 42.3)	19.1 (13.7 to 28.5)
		Rel. A	6.6 (3.1 to 7.5)	6.65 (3.1 to 7.5)	6.6 (3.1 to 7.5)	9.3 (0 to 9.3)	3.5 (0.9 to 4.5)	6.6 (3 to 7.5)
		Total A	14.7 (8 to 22.5)	14.9 (3.1 to 21.1)	14.7 (8 to 17.8)	30.2 (25.3 to 30.9)	2.7 (2.1 to 33.7)	14.7 (13.3 to 17.8)
0.25	0.04	Rel. D	0	0	0	0	0	0
		Rel. V	0	0	0	0	0	0
		Rel. A	0	0	0	0	0	0
		Total A	0	0	0	0	0	0
1.0	0.01	Rel. D	0	0	0	0	0	0
		Rel. V	0	0	0	0	0	0
		Rel. A	0	0	0	0	0	0
		Total A	0	0	0	0	0	0

Note: DHM = Duhamel's integral solved in a piecewise exact fashion.
 NMK = Newark β method.
 PWM = Piecewise Exact Method.
 WIL = Wilson θ method.
 CDF = Central Difference Method.
 RGK = 4th Order Runge-Kutta Method.

given in Table 6 also support this same conclusion. Table 6 differs from Table 5 by the value of T_o used, increased from 0.25 sec to 0.5 sec.

The results given in Tables 1 through 6 show that of the six numerical step-by-step procedures, the Wilson θ method is the least accurate and the Central Difference Method is the most accurate. However, the differences in the accuracy of the computed results among the six numerical step-by-step procedures for the SDOF systems are minor compared to the significance of Δt and T_g .

The impact of the change in natural period T_o from 0.25 sec to 0.5 sec for the damped SDOF systems on the accuracy of the six numerical step-by-step procedures is minor. Comparison of the results given in Tables 1 and 2 with T_g equal to 0.25 sec shows the value of T_g relative to the value of T_o has the most impact on

Table 4
Percentile Errors in Relative Displacement (Rel. D), Relative Velocity (Rel. V),
Relative Acceleration (Rel. A), and Total Acceleration (Total A) for SDOF System of
 $T_o = 0.5$ sec and $\Delta t = 0.01$ sec

T_g , sec	$\frac{\Delta t}{T_g}$	Parameter	Error in Maximum Response (Range in Errors for Peak and Valley Values)					
			DHM	NMK	PWM	WIL	CDF	RGK
0.05	0.2	Rel. D	14.6 (12.6 to 16.3)	14.6 (10.6 to 16.1)	14.6 (12.6 to 15.6)	30.4 (28 to 31.9)	11.9 (4.8 to 22.4)	14.6 (12.6 to 15.6)
		Rel. V	13.6 (13.6 to 27.3)	13.7 (13.5 to 52.6)	13.6 (13.6 to 37.7)	30.1 (29.3 to 50.7)	13.5 (13.3 to 25.5)	13.6 (13.6 to 52.5)
		Rel. A	6 (3.8 to 6)	6 (3.8 to 6)	6 (3.8 to 6)	7.3 (2.2 to 7.3)	4.8 (3 to 4.8)	6 (3.8 to 6)
		Total A	13.4 (8.6 to 17.9)	13.5 (7.3 to 16.3)	13.4 (8.6 to 15.1)	29.6 (27.8 to 32.1)	9.5 (0.7 to 39.2)	13.4 (8.6 to 17.9)
0.25	0.04	Rel. D	0	0	0	0	0	0
		Rel. V	0	0	0	0	0	0
		Rel. A	0	0	0	0	0	0
		Total A	0	0	0	0	0	0
1.0	0.01	Rel. D	0	0	0	0	0	0
		Rel. V	0	0	0	0	0	0
		Rel. A	0	0	0	0	0	0
		Total A	0	0	0	0	0	0

Note: DHM = Duhamel's integral solved in a piecewise exact fashion.
 NMK = Newark β method.
 PWM = Piecewise Exact Method.
 WIL = Wilson θ method.
 CDF = Central Difference Method.
 RGK = 4th Order Runge-Kutta Method.

accuracy of computed results when T_g and T_o are close to the same value. However, its influence is secondary compared to the influence of Δt and T_g .

In summary, for damped ($\beta = 0.05$) SDOF systems, the results presented in Tables 1 through 6 clearly demonstrate that the accuracy of all six numerical step-by-step procedures depends primarily on (a) the value of the time-step Δt used in the response analysis and (b) the frequency content contained within the ground motion. The computed values of relative acceleration are slightly more accurate than the computed values of relative displacement, relative velocity, and total acceleration.

Table 5 Percentile Errors in Relative Displacement (Rel. D), Relative Velocity (Rel. V), Relative Acceleration (Rel. A), and Total Acceleration (Total A) for SDOF System of $T_o = 0.25$ sec and $\Delta t = 0.005$ sec								
T_g , sec	$\frac{\Delta t}{T_g}$	Parameter	Error in Maximum Response (Range in Errors for Peak and Valley Values)					
			DHM	NMK	PWM	WIL	CDF	RGK
0.05	0.1	Rel. D	3.6 (0.5 to 3.9)	3.9 (0.3 to 3.9)	3.6 (0.5 to 3.9)	8.8 (0.7 to 8.9)	2 (0.3 to 6.5)	3.6 (0.4 to 3.8)
		Rel. V	3.5 (3.4 to 5.9)	3.7 (3.5 to 5)	3.5 (3.4 to 5.9)	9.0 (8 to 10.6)	3.9 (3.2 to 5.9)	4 (3.5 to 5.9)
		Rel. A	4.7 (3.5 to 4.8)	4.7 (3.7 to 5.1)	4.7 (3.6 to 5)	5.7 (3.4 to 5.7)	3.4 (2.2 to 3.6)	4.7 (3.6 to 5)
		Total A	4 (0 to 4)	4.1 (0.7 to 4.1)	4 (0 to 6.2)	9.2 (0 to 9.2)	3.5 (0.7 to 11)	4 (0 to 8.9)
0.25	0.02	Rel. D	0	0	0	0	0	0
		Rel. V	0	0	0	0	0	0
		Rel. A	0	0	0	0	0	0
		Total A	0	0	0	0	0	0
1.0	0.005	Rel. D	0	0	0	0	0	0
		Rel. V	0	0	0	0	0	0
		Rel. A	0	0	0	0	0	0
		Total A	0	0	0	0	0	0

Note: DHM = Duhamel's integral solved in a piecewise exact fashion.
 NMK = Newmark β method.
 PWM = Piecewise Exact Method.
 WIL = Wilson θ method.
 CDF = Central Difference Method.
 RGK = 4th Order Runge-Kutta Method.

4.2.8 Accuracy of numerical step-by-step procedures as a function of time-step Δt and frequency contained within the ground motion

The data contained in Tables 1 through 6 show that the accuracy of the six numerical step-by-step procedures depends on the value of the time-step Δt and the frequency of the ground motion. This subsection describes two groups of error plots for each of the four response parameters, given as functions of the variables Δt and T_g . Select data from these tables, specifically, the error corresponding to the *maximum* responses, are reordered as a function of the ratio of Δt divided by T_g in an attempt to present this information in a more useable form. The first group, Figures 13 through 16, reports the errors in relative displacement, relative velocity, relative acceleration, and total acceleration, respectively, for T_o equal to 0.25 sec. The second group, Figures 17 through 20, reports the errors in the four response parameters for T_o equal to 0.5 sec.

Table 6

Percentile Errors in Relative Displacement (Rel. D), Relative Velocity (Rel. V), Relative Acceleration (Rel. A), and Total Acceleration (Total A) for SDOF System of $T_o = 0.5$ sec and $\Delta t = 0.005$ sec

T_g , sec	$\frac{\Delta t}{T_g}$	Parameter	Error in Maximum Response (Range in Errors for Peak and Valley Values)					
			DHM	NMK	PWM	WIL	CDF	RGK
0.05	0.1	Rel. D	3.5 (1.5 to 5)	3.5 (0.9 to 5.5)	3.5 (2.5 to 5.1)	8.6 (7.5 to 9.5)	2.8 (2.7 to 5.8)	3.5 (3 to 4.3)
		Rel. V	3.4 (3.4 to 4)	3.4 (3.4 to 4.1)	3.4 (3.4 to 4)	8.5 (8.3 to 9.4)	3.4 (3.3 to 4.1)	3.4 (3.4 to 4.1)
		Rel. A	4.6 (4.3 to 4.9)	4.4 (4.3 to 4.9)	4.4 (4.3 to 4.9)	4.9 (4.1 to 5.1)	3.9 (3.8 to 4.4)	4.4 (4.3 to 4.9)
		Total A	3.3 (0.8 to 5.6)	3.3 (0.7 to 5.2)	3.3 (2.5 to 5.6)	8.4 (7.5 to 9.1)	0.1 (0 to 13)	3.3 (2.6 to 5.6)
0.25	0.02	Rel. D	0	0	0	0	0	0
		Rel. V	0	0	0	0	0	0
		Rel. A	0	0	0	0	0	0
		Total A	0	0	0	0	0	0
1.0	0.005	Rel. D	0	0	0	0	0	0
		Rel. V	0	0	0	0	0	0
		Rel. A	0	0	0	0	0	0
		Total A	0	0	0	0	0	0

Note: DHM = Duhamel's integral solved in a piecewise exact fashion.
 NMK = Newark β method.
 PWM = Piecewise Exact Method.
 WIL = Wilson Θ method.
 CDF = Central Difference Method.
 RGK = 4th Order Runge-Kutta Method.

These two groups of data, Figures 13 through 16 and Figures 17 through 20, demonstrate that the accuracy of the four response parameters computed using all six numerical step-by-step procedures clearly depends on the ratio of Δt divided by T_g . Thus, the impact of the two most important parameters on the accuracy of the computed results can be characterized in terms of a single variable. Additionally, the trends in the data are similar for each pair of companion figures, given the same response variable is being considered (e.g., for Rel. D in Figures 13 and 17; Rel. V in Figures 14 and 18; Rel. A in Figures 15 and 19; and Total A in Figures 16 and 20). These eight figures show that the error in all response parameters increases with increasing values of the ratio $\Delta t/T_g$. The error in maximum responses for the four response parameters ranges in value from a low of 2.8 percent to a high of 31.4 percent with the ratio $\Delta t/T_g$ equal to 0.2. However, reducing the ratio $\Delta t/T_g$ from 0.2 to 0.1 reduces the error in maximum response for all four response parameters to less than 10 percent.

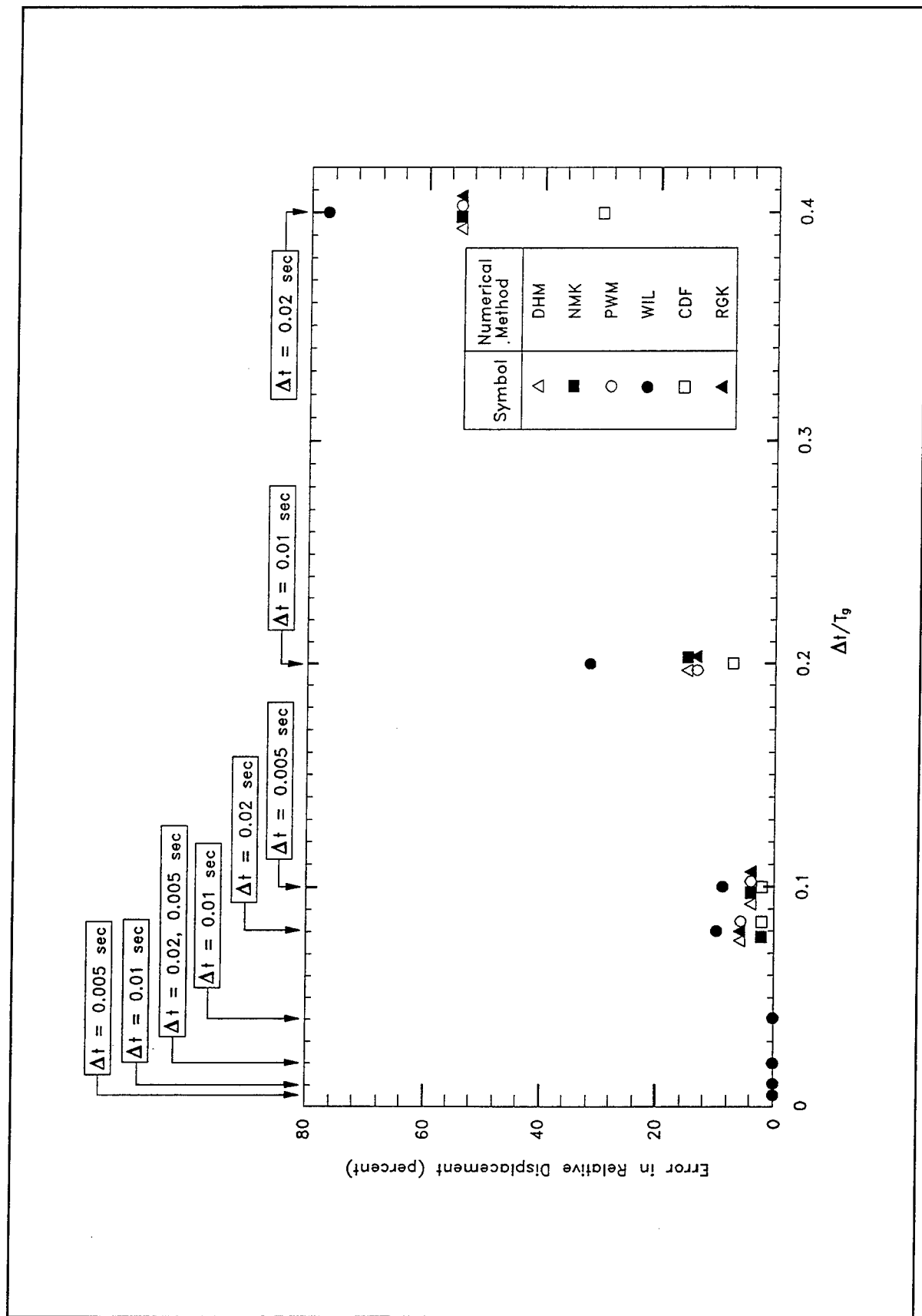

Figure 13. Percentile errors in maximum relative displacements (peak or valley value) for SDOF system of $T_0 = 0.25$ sec

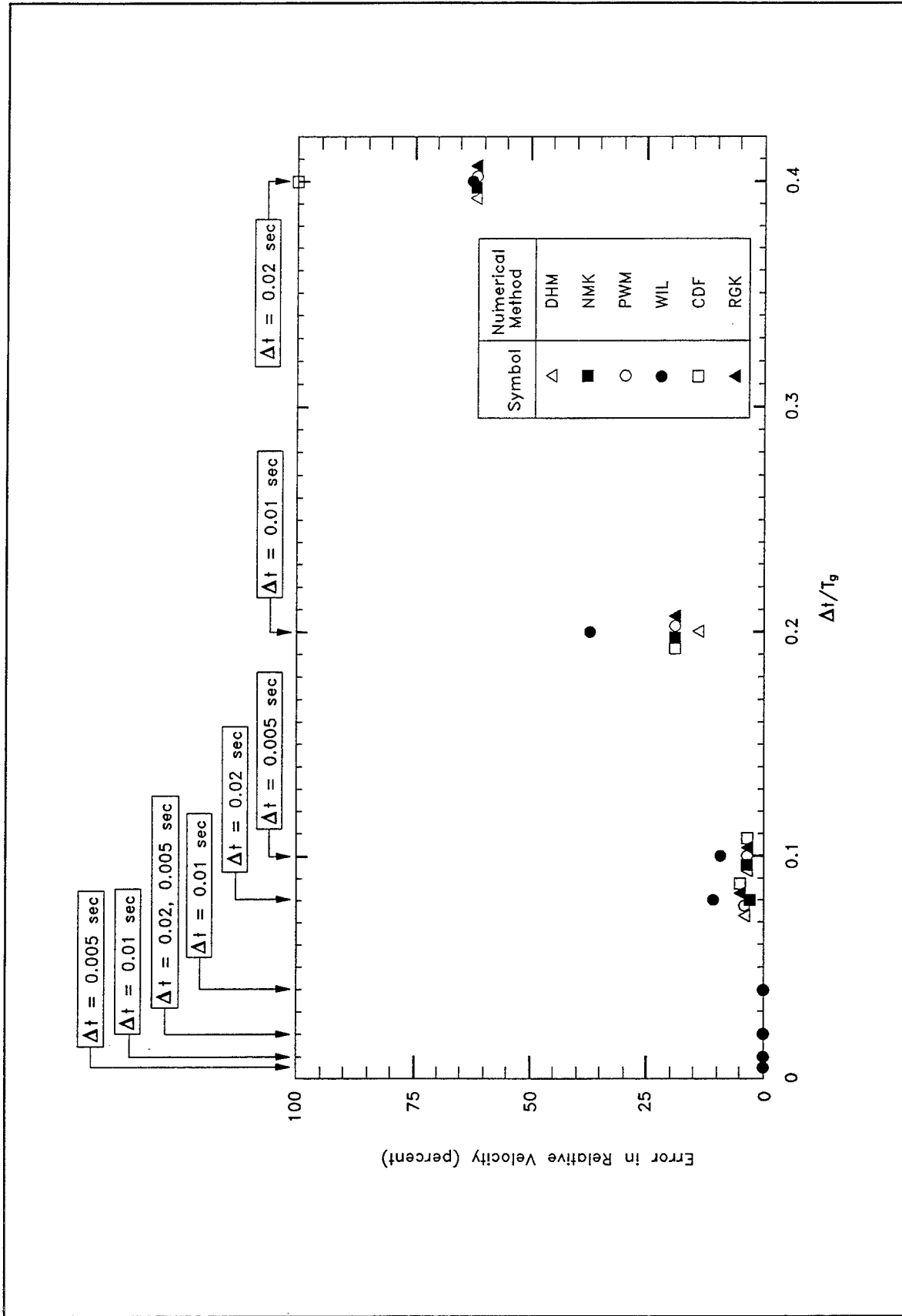

Figure 14. Percentile errors in maximum relative velocity (peak or valley value) for SDOF system of $T_0 = 0.25$ sec

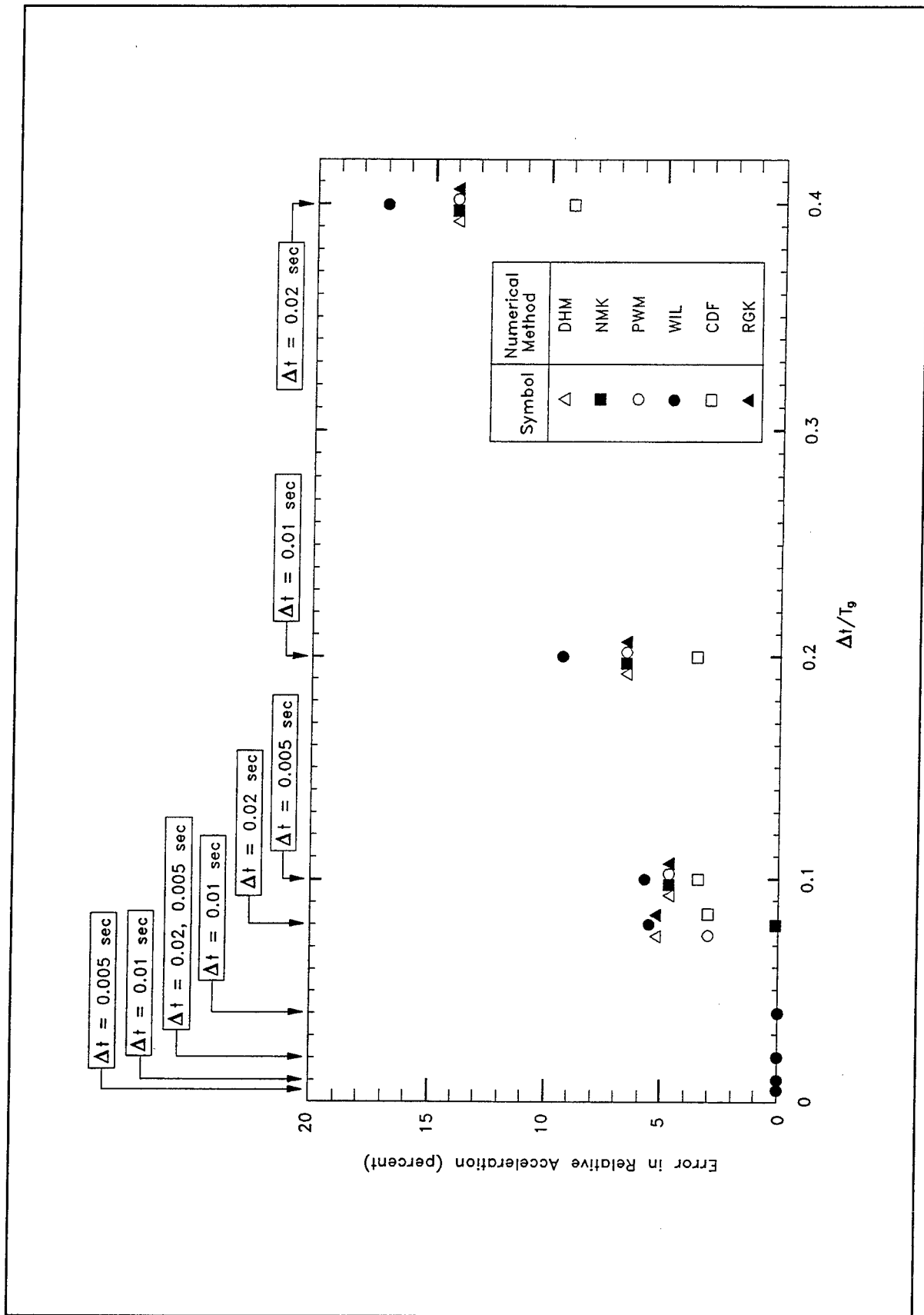

Figure 15. Percentile errors in maximum relative acceleration (peak or valley value) for SDOF system of $T_0 = 0.25$ sec

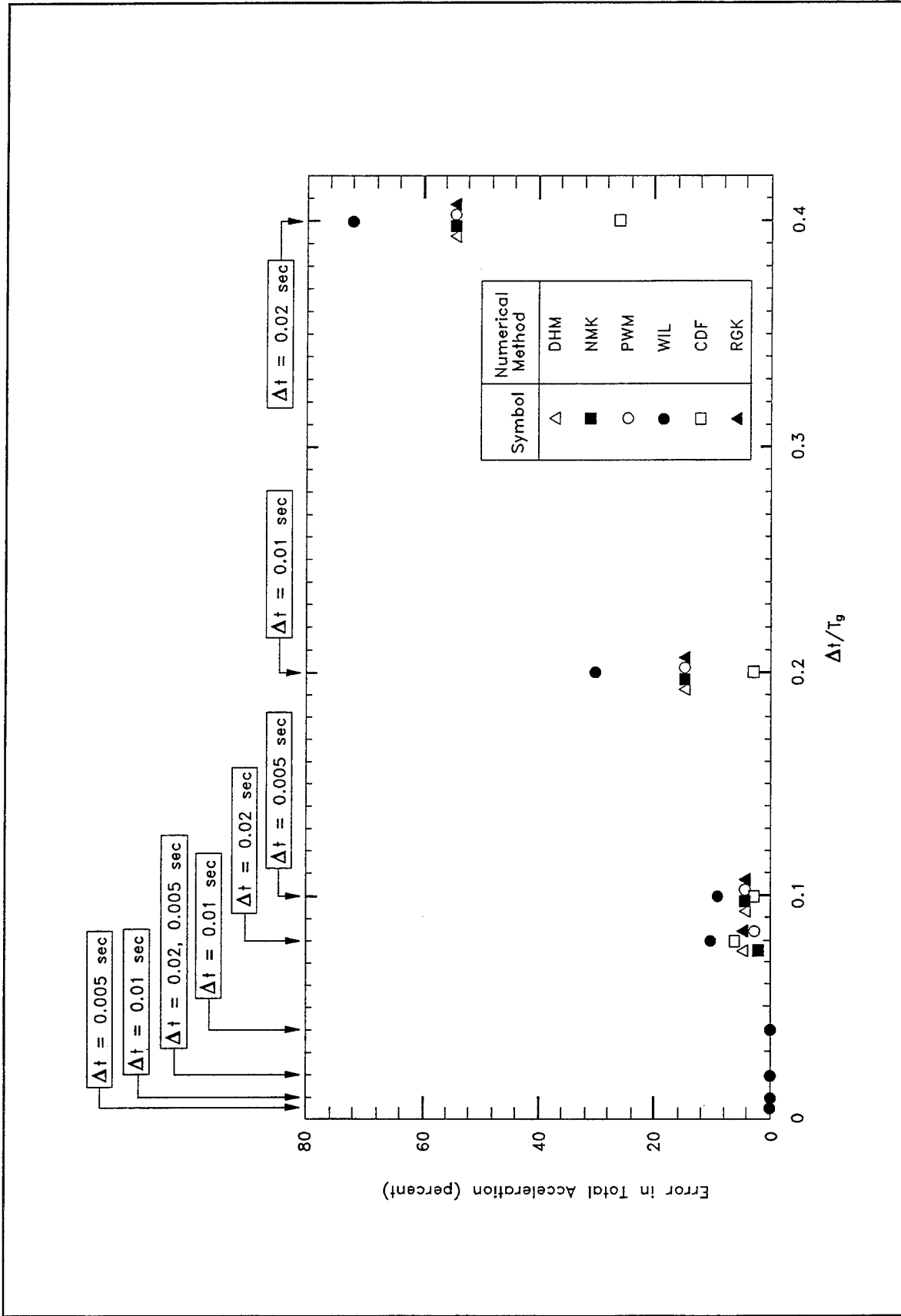

Figure 16. Percentile errors in maximum total acceleration (peak or valley value) for SDOF system of $T_0 = 0.25$ sec

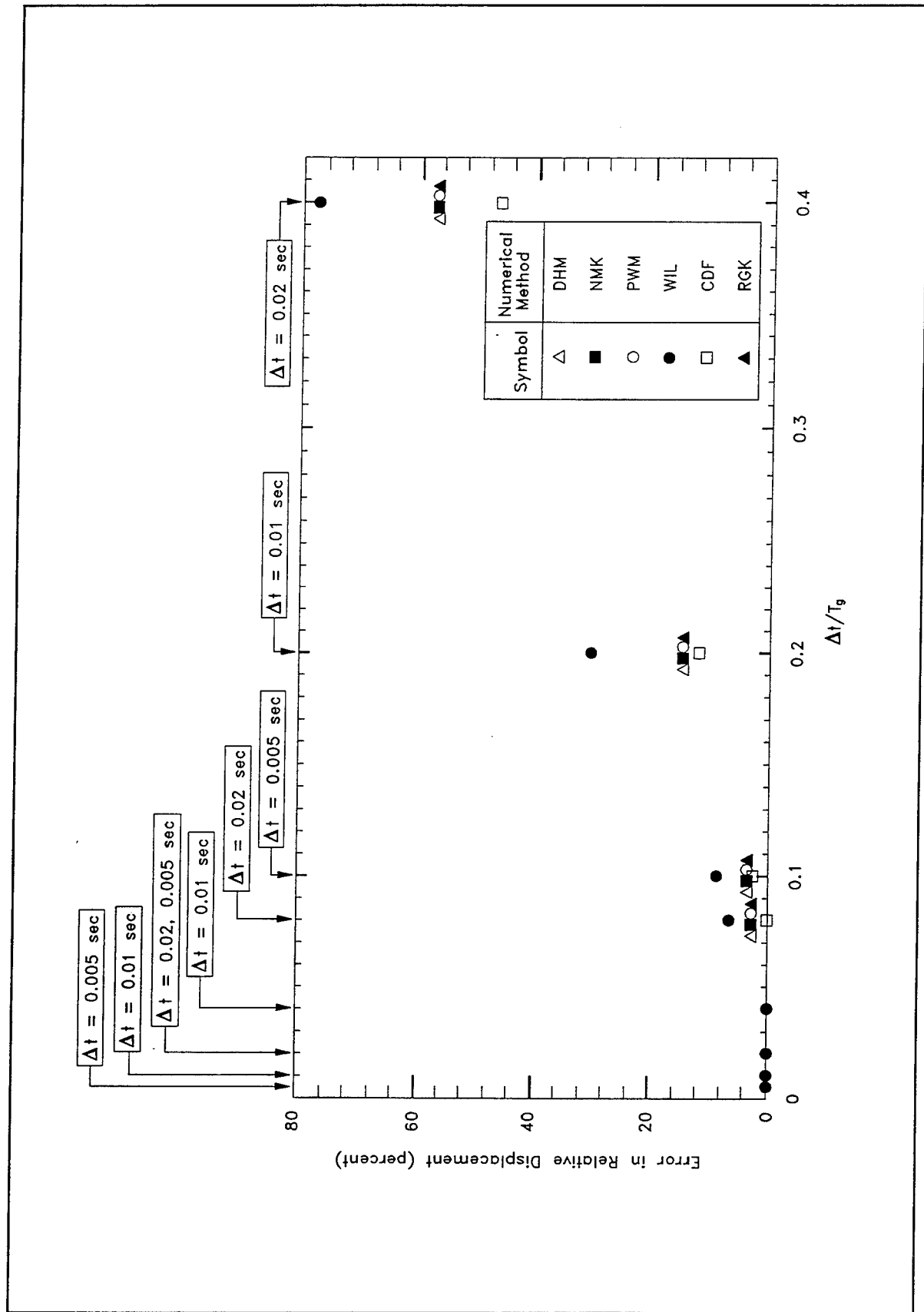

Figure 17. Percentile errors in maximum relative displacements (peak or valley value) for SDOF system of $T_0 = 0.5$ sec

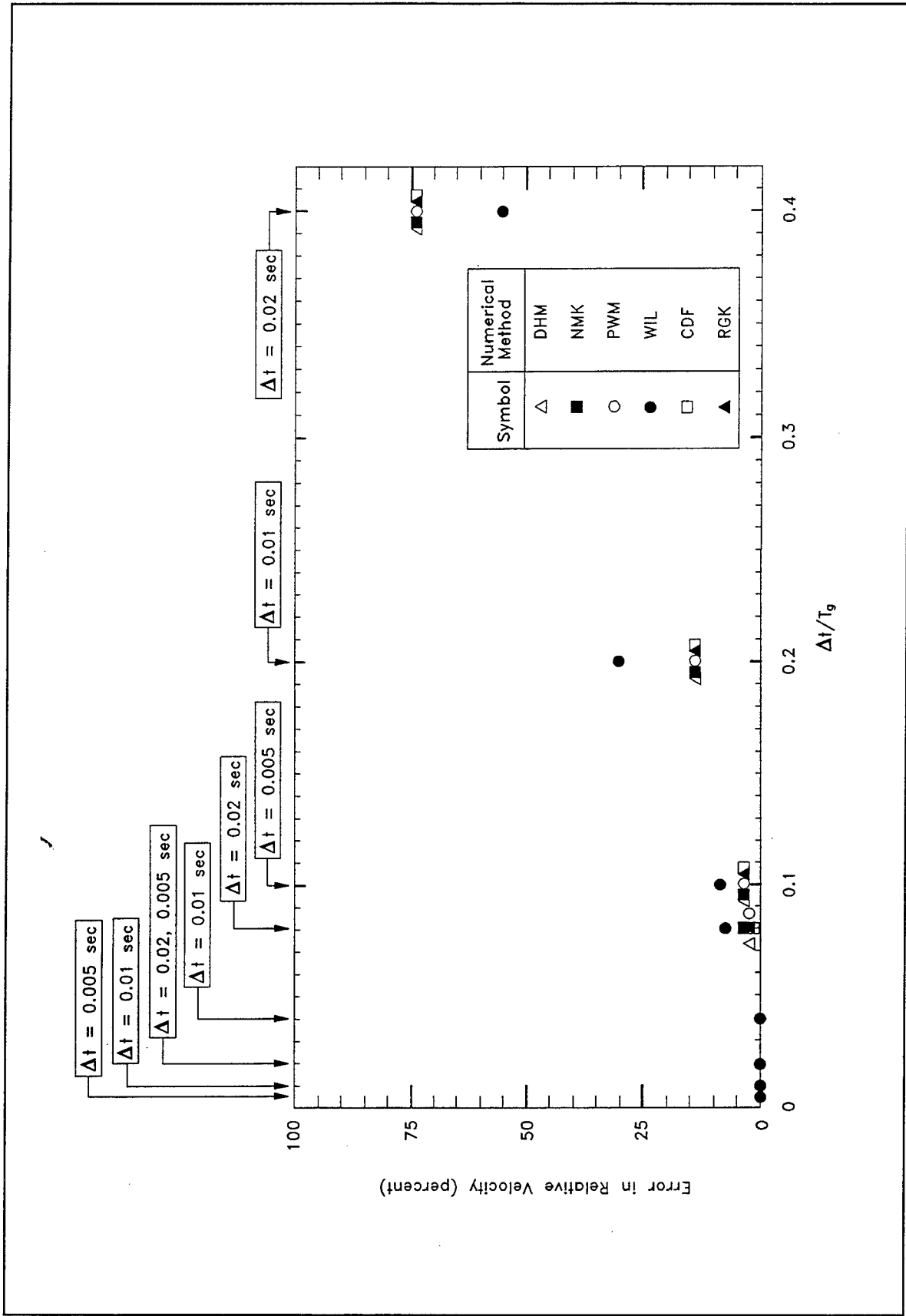

Figure 18. Percentile errors in maximum relative velocity (peak or valley value) for SDOF system of $T_o = 0.5$ sec

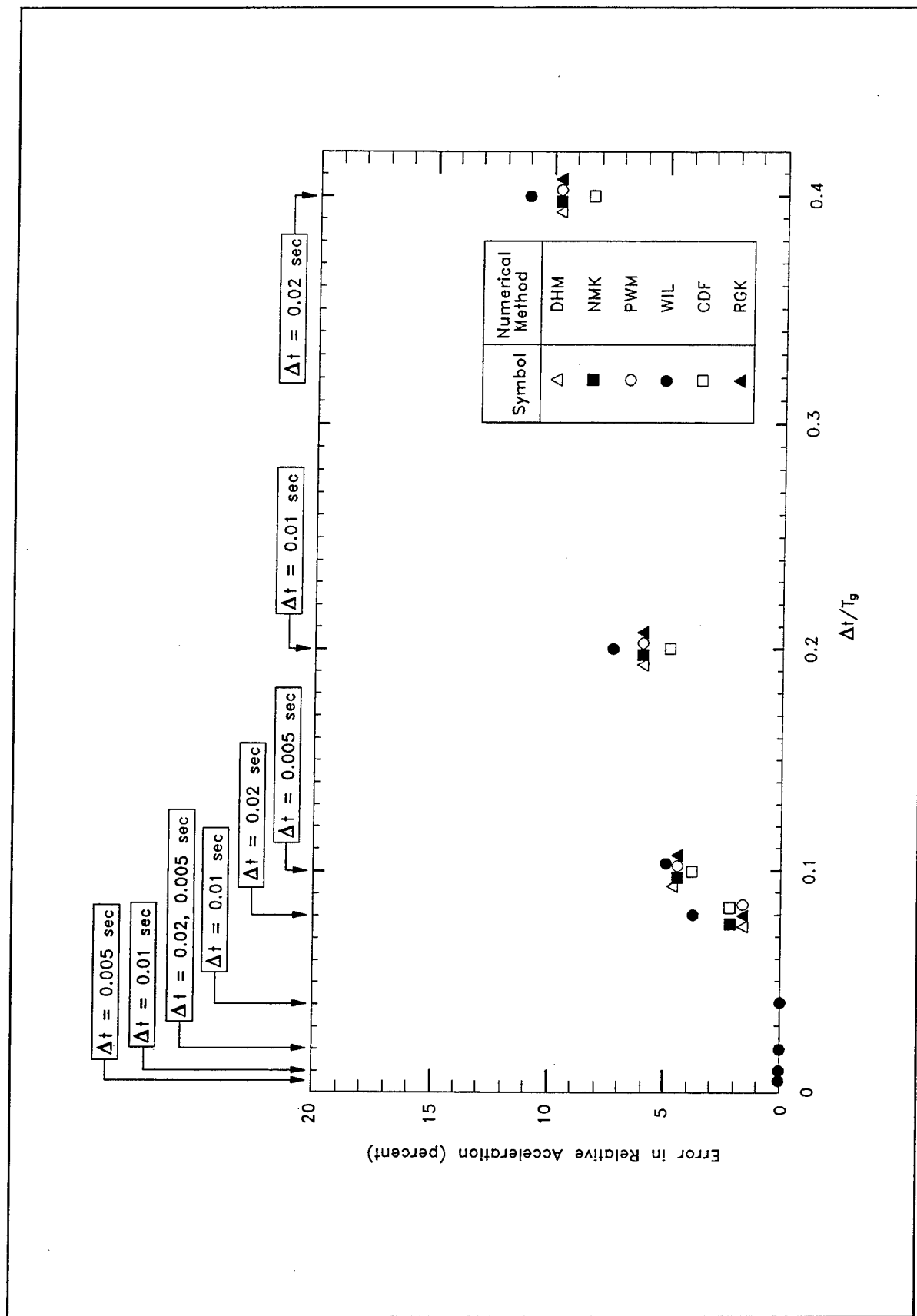

Figure 19. Percentile errors in maximum relative acceleration (peak or valley value) for SDOF system of $T_0 = 0.5$ sec

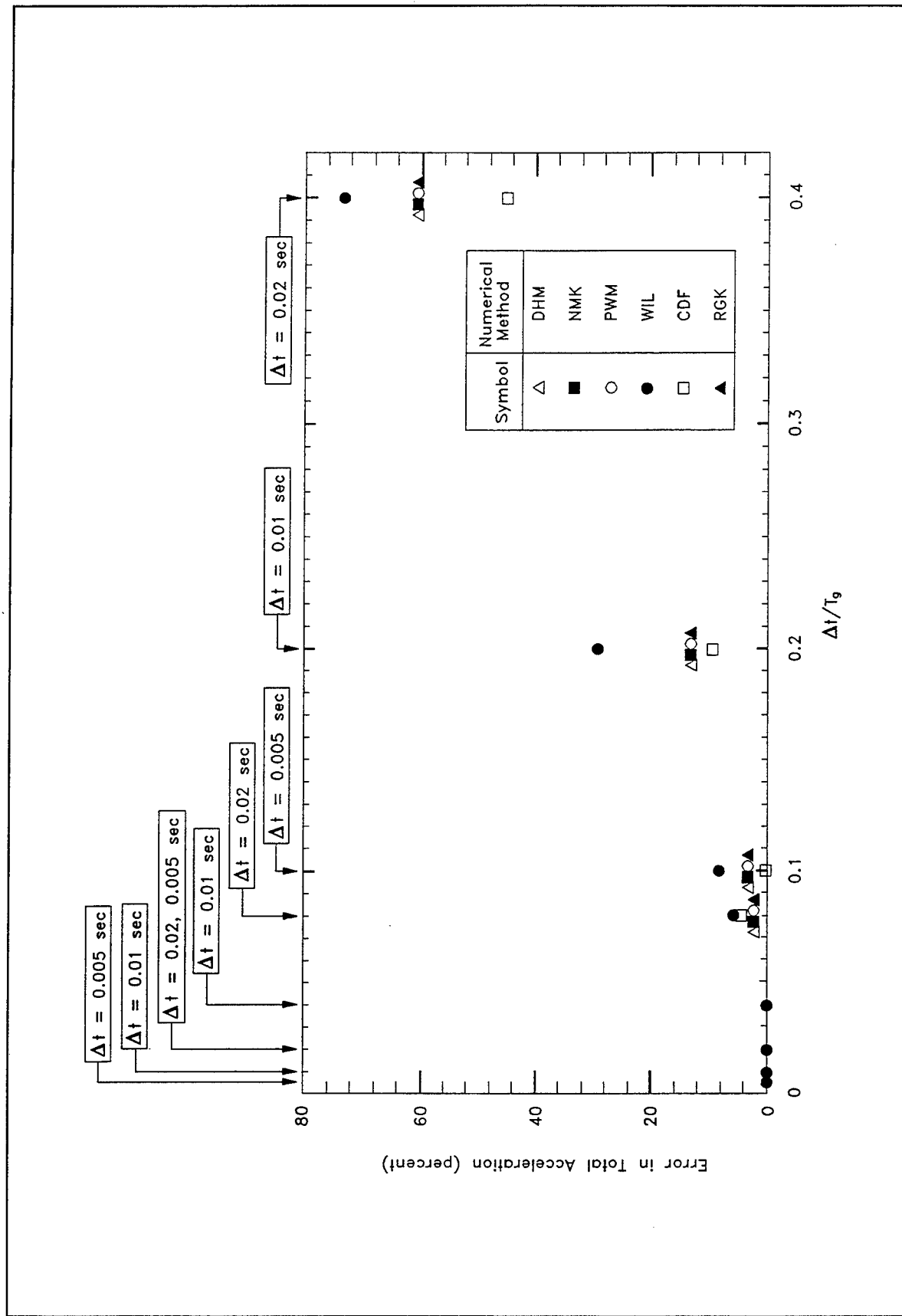

Figure 20. Percentile errors in maximum total acceleration (peak or valley value) for SDOF system of $T_0 = 0.5$ sec

4.3 Conclusions

The accuracy of six numerical step-by-step procedures of analysis of the equation of motion for SDOF system models is discussed in this chapter. *Current guidance* for the selection of the time-step Δt is based on studies of the accuracy of numerical methods using the computed results from *free vibration* response analyses of undamped SDOF systems combined, frequently, with useful but *qualitative* reference to the frequency characteristics of the forcing function. This time-step Δt criterion is expressed as a fraction of the natural (undamped) period of the SDOF system for a specified level of accuracy. The results of the numerical response calculations made in this study of the *forced vibration* response problem in which a ground acceleration is applied at the base of a damped SDOF system adds to this body of information.

Using damped SDOF system models with natural periods assigned based on consideration of the important modal periods of hydraulic structures ($T_o = 0.25$ and 0.5 sec), an extensive numerical evaluation is made of the accuracy of the computed response values solved at regular increments in time during ground motion. These error assessments are given for the four response variables of relative displacement, relative velocity, relative acceleration, and total acceleration. This assessment involved the evaluation of 432 response time-histories. The following conclusions are made regarding the factors affecting the accuracy of results computed using each of the six numerical step-by-step procedures in this study:

- a. The two variables shown to have the most influence on the accuracy of the computed results for the four response parameters are the time-step Δt and the frequency content of the ground motion (characterized by f_g or, equivalently, T_g).
- b. The accuracy in the computed results for the four response parameters increases as the value assigned to Δt decreases.
 - (1) A value of Δt equal to 0.02 sec for the damped SDOF systems analyzed would be acceptable for long-period ground motion ($T_g = 1$ sec, $f_g = 1$ Hz), but not acceptable for high-frequency ground motion ($T_g = 0.05$ sec, $f_g = 20$ Hz).
 - (2) A reduction in the time-step Δt from 0.02 sec to 0.01 sec remarkably improves the accuracy in computed response. However, inaccuracies are still present in the response values for all six numerical step-by-step procedures for the high-frequency ground motion ($T_g = 0.05$ sec, $f_g = 20$ Hz).
 - (3) A further reduction in the time-step Δt from 0.01 sec to 0.005 sec eliminates all errors for the six numerical methods in all but the high-frequency ground motion ($T_g = 0.05$ sec, $f_g = 20$ Hz). The range in

errors for peak and valley values and the error in maximum response for the four response parameters is less than 10 percent.

- c. The accuracy in the computed results for the four response parameters increases as the frequency content of the ground motion decreases (as $f_g \rightarrow 0$ or, equivalently, as $T_g \rightarrow \infty$).
- d. The accuracy in the computed results for the four response parameters is shown to correlate with the ratio $\Delta t/T_g$. Thus, the impact of the two most important parameters on the accuracy of the computed results can be characterized in terms of a single variable. The results show that accuracy considerations require the value for the ratio $\Delta t/T_g$ to be less than 0.2. A value of 0.1 for the ratio $\Delta t/T_g$ is shown to be sufficiently accurate for all six numerical step-by-step procedures.
- e. The value of T_g relative to the value of T_o has the most impact on accuracy of computed results when T_g and T_o are close to the same value. However, its influence is secondary compared with the influence of Δt and T_g .
- f. The computed values of relative acceleration are slightly more accurate than the computed values of relative displacement, relative velocity, and total acceleration.
- g. The results show that of the six numerical step-by-step procedures, the Wilson θ method is the least accurate and the Central Difference Method is the most accurate. An improvement in the accuracy of results computed using the Wilson θ method will be achieved if θ is set equal to 1.42, rather than the 1.38 value used in this study, according to Chopra (1995, page 581). However, the differences in the accuracy of the computed results among the six numerical step-by-step procedures for the SDOF systems are minor compared with the significance of Δt and T_g .

5 Results and Conclusions

5.0 Introduction

This report summarizes an assessment of the accuracy of six numerical step-by-step procedures used in computational structural dynamics. The six algorithms used in this study are representative of the different types of procedures used to compute the dynamic structural response to a time-dependent loading. The time-dependent loading envisioned in this research is that of the *motion of the ground* below a discrete structural model and is expressed in terms of a ground acceleration time-history. The dynamic structural response for each structural model used in this study is characterized by the computed response time-histories of accelerations, velocities, and displacements.

All structural models used in this study were linear, single-degree-of-freedom (SDOF) systems. The natural (undamped) periods T_o of these SDOF systems were selected based on consideration of the important modal periods of hydraulic structures such as gravity dams, arch dams, gravity lock walls, U-frame locks, and intake towers. Each of the forcing functions used in this study was single-frequency harmonics. The use of a single frequency facilitated the evaluation of the accuracy of the computed response values solved for at regular time increments during ground motion.

The time increments Δt used in this study were 0.02, 0.01, and 0.005 sec. These values are typical of the Δt used in discretizing earthquake acceleration time-histories recorded in the field on strong motion accelerographs.

The six algorithms included in this study were the Newmark β method (with values of constants γ and β corresponding to the linear acceleration method), the Wilson θ method, the Central Difference Method, the 4th Order Runge-Kutta method, Duhamel's integral solved in a piecewise exact fashion, and the Piecewise Exact Method applied directly. All of these algorithms were used in their discretized forms (i.e., the loading and response histories were divided into a sequence of time intervals); thus, they are characterized as step-by-step procedures.

The selection of the size of the time-step Δt to be used in the step-by-step calculation of the dynamic response of the SDOF (and of MDOF semidiscrete

structural models) is restricted by stability and/or accuracy considerations. The primary requirement of a numerical algorithm is that the computed response converge to the exact response as $\Delta t \rightarrow 0$ (Hughes 1987). However, the number of computations increases as the time-step Δt is made smaller in a dynamic analysis, an important issue for response analysis of semidiscrete MDOF structural system models.

In addition to accuracy considerations, stability requirements must also be considered during the selection of the time-step Δt to be used in a step-by-step response analysis by either of the three numerical integration methods or by the numerical differentiation method. Stability criterion is expressed in terms of a *maximum allowable* size for the time-step $\Delta t_{critical}$. The value for $\Delta t_{critical}$ differs among the four numerical algorithms.

No stability criterion (expressed in terms of a limiting time-step value) is needed for Duhamel's integral solved in a piecewise exact fashion and the Piecewise Exact Method applied directly. These two methods formulate exact solutions to the equation of motion for assumed forms of the time-dependent forcing functions. There is only a question of the accuracy of the assumed form for the forcing function for the size time-step Δt being used in the analysis. In general, larger time-steps are likely to make the assumed form for the forcing function less valid.

5.1 Stability Requirements for the Four Numerical Methods Used for Response Analysis

Stability requirements for *numerical methods* are expressed in terms of a limiting or critical time-step $\Delta t_{critical}$. The stability criteria for the three numerical integration methods and for the numerical differentiation method used in this study are evaluated in Chapter 3. The following conclusions are made regarding the stability requirements:

- a. The Wilson θ method with θ equal to 1.38 and the 4th Order Runge-Kutta method are unconditionally stable with no requirements made on the time-step Δt used in the analyses.
- b. The linear acceleration method, of the Newmark- β family, and the Central Difference Method are conditionally stable. However, since the SDOF systems used in this research are subjected to ground motion with Δt set equal to either 0.02, 0.01 or 0.005 sec, it is concluded that the computations using these two numerical methods are stable.

Additionally, the following observation is made: in most earthquake engineering/dynamic structural response analyses, a time-step Δt equal to either 0.02, 0.01, or 0.005 sec is commonly used to define the ground motion acceleration time-history. In general, stability will not be an issue for the computed results when using either the linear acceleration method or the Central Difference

Method for SDOF systems with T_o ranging from 0.25 sec to 0.5 sec. The time-step Δt used to accurately define the ground motion will be much smaller than the $\Delta t_{critical}$ value for either of these numerical methods.

5.2 Accuracy of Response of SDOF Systems to Ground Motion

A review is made in Section 4.1.2 of the *current guidance* for selecting the time-step Δt used in computing the dynamic response of SDOF and MDOF models to ground motion. Recall that a ground acceleration applied at the base of an SDOF system is equivalent to a fixed-base SDOF system with the forcing function applied to the mass. Current guidance is shown to be based on studies of the accuracy of numerical methods using the computed results from *free vibration* response analyses of undamped SDOF systems combined, frequently, with useful but *qualitative* reference to the frequency characteristics of the forcing function. This criterion is often expressed as a fraction of the natural (undamped) period of the SDOF system for a specified level of accuracy. The current guidance given by Chopra (1995), Gupta (1992), and the American Society of Civil Engineers (1986) Standard ASCE 4-86, on the factors to be considered in choosing the value of Δt is as follows:

- a. Chopra (1995, pages 172-173) concludes his discussion of computational error with the observations that "... the time step should be short enough to keep the distortion of the excitation function to a minimum. A very fine time step is necessary to describe numerically the highly irregular earthquake ground acceleration recorded during earthquakes; typically, $\Delta t = 0.02$ seconds is chosen and this dictates a maximum time step for computing the response of a structure to earthquake excitation."
- b. Gupta (1992, page 155) recommends that "the time step used in the response computations is selected as the smaller of the digitized interval of the earthquake accelerogram or some fraction of the period of free vibration, for example $T/10$."
- c. The ASCE 4-86 Standard (page 21) states that an acceptable rule for time-history response analysis is that the time-step Δt used be small enough such that the use of $1/2\Delta t$ does not change the response by more than 10 percent. For the commonly used numerical step-by-step procedures of Wilson θ and Newmark β , the maximum time-step size should be one-tenth ($1/10$) the shortest period of interest, and for the Piecewise Exact Method (or Nigam-Jennings Method) the maximum time-step size should be one-fifth ($1/5$) the shortest period of interest. Normally, the shortest period of interest need not be less than 0.03 sec (33 Hz for nuclear structures).

Paz (1991, page 155), Gupta (1992, page 155), Clough and Penzien (1993, pages 128-129), and Chopra (1995, pages 172-173) all recognize that the assignment of time-step Δt in response analysis to forced vibration should consider the following factors:

- a. The natural period of the structure.
- b. The rate of variation of the loading function.
- c. The complexity of the stiffness and damping functions.

Using damped SDOF system models ($\beta = 0.05$) with natural periods assigned based on consideration of the modal periods of hydraulic structures with significant response contribution ($T_o = 0.25$ and 0.5 sec), an extensive numerical evaluation is made of the accuracy of the computed response values solved for at regular increments in time during ground motion. The numerical results, given in Tables 1 through 6 and in Figures 13 through 20, show the interrelationship between the accuracy of the six numerical step-by-step procedures with the harmonic characteristics of the ground motion (using $T_g = 0.05$, 0.25 and 1 sec) and the time-step Δt value (0.02 , 0.01 or 0.005 sec) used in the analysis of each of the damped SDOF systems. These error assessments are given for the four response variables of relative displacement, relative velocity, relative acceleration, and total acceleration. The following conclusions are made regarding the accuracy of the six numerical step-by-step procedures used in this study:

- a. All six numerical step-by-step procedures provide accurate results for ground motion with a range in frequency f_g from 1 Hz to 20 Hz (or, equivalently, T_g from 0.05 sec to 1 sec) when a 0.005 -sec time-step is used in the numerical analysis.
- b. The accuracy of computed results diminishes with increasing time-step value used in the numerical step-by-step analysis.
- c. Numerical errors are observed when solving for the SDOF system response to high-frequency ground motion ($f_g = 20$ Hz or $T_g = 0.05$ sec) when the time-step Δt is increased from 0.005 sec to 0.01 sec in the numerical response analysis. No numerical errors are observed when solving for the SDOF system response to intermediate and low-frequency ground motions ($f_g = 4$ and 1 Hz or $T_g = 0.25$ and 1 sec) when the time-step Δt is set equal to 0.01 sec in the numerical analysis.
- d. Numerical errors are observed when solving for the SDOF system response to the entire spectrum of ground motion frequencies ($f_g = 20$ Hz or $T_g = 0.05$ sec, $f_g = 4$ Hz or $T_g = 0.25$ sec, and $f_g = 1$ Hz or $T_g = 1$ sec) when the time-step Δt is increased from 0.01 sec to 0.02 sec in the numerical analysis. The magnitudes of these errors increase as the frequency f_g contained within the ground motion increases. The magnitude of error for

some response parameters is likely to be unacceptable with Δt set equal to 0.02 sec in the response analysis.

- e. The accuracy in the computed results for the four response parameters increases as the frequency content of the ground motion decreases (as $f_g \rightarrow 0$ or, equivalently, as $T_g \rightarrow \infty$).
- f. The accuracy in the computed results for the four response parameters is shown to correlate with the ratio $\Delta t/T_g$. Thus, the impact of the two most important parameters on the accuracy of the computed results can be characterized in terms of a single variable. The results show that accuracy considerations require the value for the ratio $\Delta t/T_g$ to be less than 0.2. A value of 0.1 for the ratio $\Delta t/T_g$ is shown to be sufficiently accurate for all six numerical step-by-step procedures.
- g. The value of T_g relative to the value of T_o has the most impact on accuracy of computed results when T_g and T_o are close to the same value. However, its influence is secondary compared with the influence of Δt and T_g .
- h. The computed values of relative acceleration are slightly more accurate than the computed values of relative displacement, relative velocity, and total acceleration.
- i. The results show that of the six numerical step-by-step procedures, the Wilson θ method is the least accurate and the Central Difference Method is the most accurate. The accuracy of results computed using the Wilson θ method will be improved if θ is set equal to 1.42, rather than 1.38 used in this study, according to Chopra (1995, page 581). However, the differences in the accuracy of the computed results among the six numerical step-by-step procedures for the SDOF systems are minor compared with the significance of Δt and T_g .

The authors envision that the error summaries given in Tables 1 through 6 and in Figures 13 through 20 may be used to establish an acceptable time-step Δt value to be used in earthquake engineering dynamic response analyses of SDOF structures (with $\beta = 0.05$) using any one of the six numerical step-by-step procedures. The scenario may be as follows: Information regarding the frequencies contained within the acceleration time-history is made available (e.g., from response spectra or Fourier amplitude plots). For a predefined level of accuracy in response parameter(s) and given knowledge of the frequency characteristics of the ground motion (i.e., f_g or T_g), these tables and figures may be used to establish the minimum Δt value for accuracy considerations. The three possible outcomes are as follows:

- a. The minimum Δt value for accuracy considerations is smaller than the Δt value contained within this ground motion that was initially proposed for use in the structural response analysis. This situation will require replacement of the initial ground acceleration time-history (used to generate this

initial f_g, T_g information) with one that has been processed at this finer time-step so that numerical error(s) contained within the dynamic structural response analysis will be within acceptable levels.

- b. The minimum Δt value for accuracy considerations is much larger than the Δt value contained in this (initial) acceleration time-history. Considerations related to computational efficiency in the dynamic structural response analysis (i.e., engineering costs) may dictate that a coarser time-step be used in the response analysis. The time-step may be increased by first transferring the acceleration time-history signal to the frequency domain and then returning the signal back to the time domain but with a new, coarser time-step.
- c. The minimum Δt value for accuracy considerations is equal to the Δt value contained in the initially selected ground motion. The dynamic structural response analysis then proceeds using this ground motion.

5.3 Baseline Correction of Ground Motion

As a general rule to avoid inaccurate response predictions, the ground acceleration time-history used to represent earthquake excitation in the dynamic response analyses of linear SDOF and semidiscrete MDOF structural models shall be baseline corrected. Baseline correction is essential in the response analysis of nonlinear structural systems.

5.4 Observations Made Regarding Response Analysis of Semidiscrete MDOF System Models

Discussions in this report regarding the accuracy of computed response using six numerical step-by-step procedures have focused on the response analysis of SDOF systems. This section discusses some observations made regarding response analysis of semidiscrete MDOF system models.

In general, the numerical step-by-step procedures used in solving linear SDOF systems in this report are easily extended to deal with MDOF models by replacing the Chapter 2 scalar quantities by matrices. This type of formulation is a *direct solution of the equation of motion* (the matrix form of Equation 5 in Chapter 2). Thus, the solution for the time-history of response is performed directly by a numerical step-by-step algorithm dealing *simultaneously* with all degrees of freedom (DOF) in the response vector. However, for an MDOF model of a hydraulic structure, such as an arch dam, with a large number of DOF's, it is computationally advantageous to transform the equation of motion to modal coordinates before carrying out the time response analysis. The reason is that, in most cases, the significant response of the dam structure can be adequately described by the

few lowest vibration modes, and thus solution of the complete set of equations is avoided (Ghanaat 1993). For example, Engineer Manual (EM) 1110-2-2201 (Headquarters, U.S. Army Corps of Engineers, 1994, pages 7-12 and 7-13) states that for linear-elastic response, a sufficient number of modes should be included so that at least 90 percent of the total dynamic response is achieved. For large arch dams this usually involves all vibration modes with frequencies less than 10 Hz. Smaller arch dams, which are stiffer, may reach their 90 percent level of responses when all vibration modes under 20 Hz are considered.

This second type of formulation makes use of modal methods to transform the extensive number of equations of motion for the MDOF system model into *uncoupled modal equations for a much smaller series of SDOF equations of motion*. These transformed SDOF equations of motion are solved at each step in time (i.e., time t , $t + \Delta t$, $t + 2\Delta t$, etc.). *Superposition is used to combine responses* computed by each SDOF equation of motion in each mode, for the complete dynamic response of MDOF model at each increment in time. A change from the actual (i.e., finite element) coordinate basis is made to the basis of eigenvectors for the modal generalized equations in this formulation. Lastly, because superposition is employed in the analytical formulation, use of this procedure is restricted to *linear* MDOF models. Refer to Bathe and Wilson (1976), Clough and Penzien (1993), Ghanaat (1993), or Chopra (1995) for additional details regarding this formulation.

5.4.1 Stability requirements

The stability criterion for the linear acceleration method and the Central Difference Method, expressed in terms of a critical time-step $\Delta t_{critical}$, was shown not to be restrictive on the response analyses for the SDOF systems analyzed in Chapter 4. Recall that for the SDOF system with T_o equal to 0.25 sec, the smallest values of $\Delta t_{critical}$ are computed to be 0.138 sec for the linear acceleration method and 0.08 sec for the Central Difference Method. The time-steps Δt used in the SDOF response analyses are set equal to 0.02, 0.01, and 0.005 sec (Chapter 4).

The stability of a numerical method is a critical consideration in the analysis of MDOF semidiscrete structural models to earthquake excitation. Along with others, Chopra (1995, page 566) observes that conditionally stable procedures can be used effectively for analysis of *linear response* of large MDOF semidiscrete structural models by time history-modal response analysis. This flexibility is due to the fact that only those (lower) modes that contribute to the MDOF model response are typically used in the time-history response computations and, thus, control the assignment of the largest time-step Δt that can be used in the numerical analysis (Chopra 1995, pages 574-575, or Hughes 1987, page 493). Chopra (1995, page 575) observes that when using a direct solution of the equations of motion of a large, semidiscrete MDOF system model or when *all modes* are included in a time history-modal response analysis, the limiting time-step

associated with conditionally stable algorithms may be prohibitive. Unconditionally stable numerical methods are usually more advantageous for these response analyses.

5.4.2 Accuracy of response

All numerical step-by-step procedures used in solving linear MDOF system models must be cognizant of the issue of accuracy, whether the formulation used is a direct solution of the equation of motion (the matrix form of Equation 5 in Chapter 2) or when using time history-modal response analysis. This numerical investigation of the accuracy of response of SDOF systems to base excitation did not include MDOF system models. Additionally, it is recognized that there are many different types of MDOF system response analysis formulations and each is likely to have its own unique characteristics with regard to the issue of accuracy of computed response(s). Some of the factors contributing to these differences include not only the general solution formulation to the equation of motion for the MDOF system model, but also the finite element stiffness and mass formulations used in the model, as well as the method used to incorporate damping in the analysis. In the interim, and until the results from additional detailed numerical studies become available, the following approximation is suggested to answer the question: Is the time-step in which the ground acceleration time-history is discretized sufficiently small to provide for an adequate level of accuracy in the computed dynamic structural response(s) for the damped semidiscrete MDOF system model ($\beta = 0.05$)?

- a. Make an initial selection of a ground acceleration time-history for the project and make available information regarding the frequencies contained within the acceleration time-history.
- b. Develop a semidiscrete or discrete (finite element) model of the hydraulic structure and conduct a modal analysis to identify the first J modes with a *significant* contribution to system response for the MDOF model comprising N modes (with $J < N$). For many types of hydraulic structures the dynamic response is often dominated by the first few modes (i.e., $J \ll N$). A sufficient number of modes have been identified if the sum of the modal mass participation factors is greater than or equal to 90 percent. Alternatively, simplified procedures may be used to approximately compute these modal periods (when these procedures are available for the type of hydraulic structure being analyzed). Use of simplified procedures is entirely appropriate in this exercise to compute the natural periods of these J modes. For example, Fenves and Chopra (1986) describe a simplified procedure to compute the natural period of a concrete gravity dam section. Experience has shown that dynamic response of concrete gravity dams is dominated by first mode response ($J = 1$). A simplified procedure for computing the first two modal periods ($J = 2$) of intake towers (developed by the third and first authors of this report) is described in Appendix B of Engineer Circular 1110-2-285 (Headquarters, U.S. Army Corps of

Engineers, 1995). Experience has shown that dynamic response of intake towers is dominated by the first two modes.

- c. Given the frequency content of the ground motion f_g of interest and the Δt to which the acceleration time-history is discretized, use the error summaries given in Tables 1 through 6 and in Figures 13 through 20 to assess the accuracy of computed response(s) for each of the J modes. Since the data given are only for two natural periods (i.e., $T_o = 0.25$ sec and $T_o = 0.5$ sec), interpolation/extrapolation may be required.
- d. For hydraulic structures whose dynamic response is dominated by first mode response, the error computed in step 3 (c) is the approximation for the accuracy of computed response for the time-step Δt for which the ground acceleration time-history is discretized. An assessment of the adequacy of the error in computed response is then made. If deemed acceptable, step 3 is repeated for all other response parameters of interest. If any response parameter error is deemed unacceptable, another ground acceleration time-history possessing a finer time-step should be obtained. Recall that the time-step Δt for ground acceleration time-histories is usually equal to 0.02, 0.01, or 0.005 sec. The process should be repeated using this new acceleration time-history.
- e. For hydraulic structures whose response is dominated by contributions of more than one mode, the results from the following two simplified procedures should be considered: (1) approximate the total error in the specified response parameter as the largest of the response errors of the modes; or (2) approximate the total error as the weighted sum of the error of each mode. The value assigned to each weighting factor is intended to account for contribution of that mode to the total response. Values of the mass modal participation factors are expected to be useful data in this evaluation.

5.4.3 Numerical damping of high-frequency response

Numerical damping in a step-by-step analysis of a semidiscrete MDOF structural model is advantageous because it filters out response contributions from high-frequency modes that result from the numerical structural model idealization and not an actual property of the structure. Chopra (1995, page 576) observes that "Wilson's method provides for numerical damping in modes with period T_n such that $\Delta t/T_n \geq 1.0$; other methods are also available." Refer to Chopra (1995, pages 575-576) or to Hughes (1987, pages 498-499) for further details regarding this topic.

5.4.4 Nonlinear analysis

Classical modal analysis is not used for time-history response analysis of nonlinear structural systems because of coupling between modal equations (Chopra 1995, page 574). Unconditionally stable procedures are generally necessary for nonlinear response analysis of such systems (Chopra 1995, page 566).

References

- American Society of Civil Engineers. (1986 (Sep)). "Seismic analysis of safety-related nuclear structures" and "Commentary on standard for seismic analysis of safety related nuclear structures," ASCE 4-86, New York.
- Bathe, K. A. (1982). *Finite element procedures in engineering analysis*. Prentice-Hall, Englewood Cliffs, NJ.
- Bathe, K. A., and Wilson, E. W. (1976). *Numerical methods in finite element analysis*. Prentice-Hall, Englewood Cliffs, NJ.
- Chopra, A. K. (1981). *Dynamics of structures: A primer*. Earthquake Engineering Research Institute, Oakland, CA.
- Chopra, A. K. (1995). *Dynamics Of structures: Theory and applications to earthquake engineering*. Prentice-Hall, Englewood Cliffs, NJ.
- Clough, R.W., and Penzien, J. (1993). *Dynamics of structures*. 2nd ed., McGraw-Hill, New York.
- Ebeling, R. M. (1992). "Introduction to the computation of response spectrum for earthquake loading," Technical Report ITL-92-4, U.S. Army Engineer Waterways Experiment Station, Vicksburg, MS.
- Fenves, G., and Chopra, A. K. (1986 (Jun)). "Simplified analysis for earthquake resistant design of concrete gravity dams," Report No. UCB/EERC-85/10, Earthquake Engineering Research Center, University of California, Berkeley, CA.
- Ghanaat, Y. (1993). "Theoretical manual for analysis of arch dams," Technical Report ITL-93-1, U.S. Army Engineer Waterways Experiment Station, Vicksburg, MS.
- Gupta, A. K. (1992). *Response spectrum method in seismic analysis and design of structures*, CRC Press, Boca Raton, FL.

- Headquarters, U.S. Army Corps of Engineers. (1994 (31 May)). "Arch dam design," Engineer Manual No. 1110-2-2201, Washington, DC.
- Headquarters, U.S. Army Corps of Engineers. (1995 (30 Sep)). "Structural analysis and design of intake structures for outlet works," Engineer Circular No. 1110-2-285, Washington, DC. (Expires 30 Sep 1997).
- Hudson, D. E. (1979). "Reading and interpreting strong motion accelerograms," Monograph, Earthquake Engineering Research Institute, Oakland, CA.
- Hughes, T. J. R. (1987). *The linear finite element method, linear static and dynamic finite element analysis*. Prentice-Hall, Englewood Cliffs, NJ.
- Hughes, T. J. R., and Belytshko, T. (1983 (Dec)). "A precis of developments in computational methods for transient analysis," *Transactions of the ASME Journal of Applied Mechanics* 50, 1033-1041.
- Kreyszig, E. (1972). *Advanced engineering mathematics*. John Wiley and Sons, New York.
- Newmark, N. M. (1959). "A method of computation for structural dynamics," *Journal of the Engineering Mechanics Division, ASCE*, 85(EM3), 67-94.
- Nigam, N. C., and Jennings, P. C. (1968). "SPECEQ/UQ: Digital calculation of response spectra from strong-motion earthquake records," Earthquake Engineering Research Laboratory, California Institute of Technology, Pasadena, CA.
- Paz, M. (1985). *Structural dynamics, theory and computation*. 2nd Ed., Van Nostrand Reinhold, New York.
- Paz, M. (1991). *Structural dynamics, theory and computation*. 3rd Ed., Van Nostrand Reinhold, New York.
- Subbaraj, K., and Dokainish, M. A. (1989a). "A survey of direct time-integration methods in computational structural dynamics-I. Explicit methods, computers and structures," Pergamon Press (printed in Great Britain), 32(6), 1371-1386.
- Subbaraj, K., and Dokainish, M. A. (1989b). "A survey of direct time-integration methods in computational structural dynamics-II. Implicit methods, computers and structures," Pergamon Press (printed in Great Britain), 32(6), 1387-1401.
- Thomson, W. T. (1993). *Theory of vibration with applications*. 4th Ed., Prentice-Hall, Englewood Cliffs, NJ.

Appendix A

Exact Solution to SDOF System Sine Wave Base Excitation

The equation of motion for a single-degree-of-freedom system subjected to a base excitation is

$$\ddot{x}(t) + 2\beta\omega\dot{x}(t) + \omega^2x(t) = -\ddot{x}_{\text{ground}}(t) \quad (\text{A1})$$

where

$$\ddot{x}_{\text{ground}}(t) = pga \sin \bar{\omega}t \quad (\text{A2})$$

and pga is the peak ground acceleration or amplitude of sinusoidal base excitation. The solution to this differential equation is

$$x(t) = e^{-\beta\omega t} (A \cos \omega_D t + B \sin \omega_D t) - \frac{pga}{\omega^2} \left[\frac{(1 - r^2) \sin \bar{\omega}t - 2\beta r \cos \bar{\omega}t}{(1 - r^2)^2 + (2\beta r)^2} \right] \quad (\text{A3})$$

where

$$r = \frac{\bar{\omega}}{\omega}$$

and

$$\bar{\omega} = \frac{2\pi}{T_g}$$

(e.g., Clough and Penzien 1993). The values assigned to T_g and pga , the peak ground acceleration, in this study are reported in Figure 7, Chapter 4. Taking the time derivative of Equation A3 gives

$$\begin{aligned} \dot{x}(t) = & e^{-\beta\omega t} [(B\omega_D - A\omega\beta) \cos \omega_D t - (B\omega\beta + A\omega_D) \sin \omega_D t] \\ & - \frac{pga r}{\omega} \left[\frac{(1-r^2) \cos \bar{\omega} t + 2\beta r \sin \bar{\omega} t}{(r^2-1)^2 + (2\beta r)^2} \right] \end{aligned} \quad (A4)$$

The constants A and B can be determined by evaluating Equations A3 and A4 for the boundary conditions $x(t=0) = 0$, and $\dot{x}(t=0) = 0$:

$$A = \frac{pga}{\omega^2} \frac{2\beta r}{(1-r^2)^2 + (2\beta r)^2} \quad (A5)$$

and

$$B = \frac{1}{\omega_D} \left[A\omega\beta + \frac{pga r}{\omega} \frac{1-r^2}{(2\beta r)^2 + (r^2-1)^2} \right] \quad (A6)$$

The relative acceleration is determined by taking the time derivative of the relative velocity:

$$\begin{aligned} \ddot{x}(t) = & e^{-\beta\omega t} \left[\left(A\omega^2\beta^2 - 2B\omega_D\omega\beta - A\omega_D^2 \right) \cos \omega_D t \right. \\ & \left. + \left(B\omega^2\beta^2 + 2A\omega_D\omega\beta - B\omega_D^2 \right) \sin \omega_D t \right] \\ & + pga r^2 \left[\frac{(1-r^2) \sin \bar{\omega} t - 2\beta r \cos \bar{\omega} t}{(r^2-1)^2 + (2\beta r)^2} \right] \end{aligned} \quad (A7)$$

The total acceleration, $\ddot{x}_{total}(t)$, is simply the sum of the relative acceleration plus the ground acceleration

$$\begin{aligned} \ddot{x}_{total}(t) &= \ddot{x}_{ground}(t) + \ddot{x}(t) \\ &= -[2\beta\omega\dot{x}(t) + \omega^2 x(t)] \end{aligned} \quad (A8)$$

Appendix B

Fourier Series

Fourier showed that any periodic function may be expressed as the summation of an infinite number of sine and cosine terms (e.g., Paz 1985). Such a sum is known as a Fourier series:

$$P(t) = a_0 + a_1 \cos \bar{\omega}t + a_2 \cos 2\bar{\omega}t + \dots + a_n \cos n\bar{\omega}t + b_1 \sin \bar{\omega}t + b_2 \sin 2\bar{\omega}t + \dots + b_n \sin n\bar{\omega}t \quad (\text{B1})$$

or

$$P(t) = a_0 + \sum_{n=1}^{\infty} (a_n \cos n\bar{\omega}t + b_n \sin n\bar{\omega}t) \quad (\text{B2})$$

where $\bar{\omega} = 2\pi/T_g$ is the circular frequency, and T_g is the period of the base excitation. The evaluation of the coefficients a_0 , a_n , and b_n is given by

$$a_0 = \frac{1}{T_g} \int_{t_1}^{t_1+T_g} P(t) dt \quad (\text{B3})$$

$$a_n = \frac{2}{T_g} \int_{t_1}^{t_1+T_g} P(t) \cos n\bar{\omega}t dt \quad (\text{B4})$$

$$b_n = \frac{2}{T_g} \int_{t_1}^{t_1+T_g} P(t) \sin n\bar{\omega}t dt \quad (\text{B5})$$

where t_1 in the limits of the integrals may be any value of time, but is usually equal $-T_g/2$ or zero. The constant a_0 represents the average of the periodic function $P(t)$.

Representing the forcing function by a piecewise linear function, the Fourier coefficients are the summation of the integrals evaluated for each linear segment of the forcing function:

$$a_0 = \frac{1}{T_g} \sum_{i=1}^N \int_{t_{i-1}}^{t_i} P(t) dt \quad (\text{B6})$$

$$a_n = \frac{2}{T_g} \sum_{i=1}^N \int_{t_{i-1}}^{t_i} P(t) \cos n\bar{\omega}t dt \quad (\text{B7})$$

$$b_n = \frac{2}{T_g} \sum_{i=1}^N \int_{t_{i-1}}^{t_i} P(t) \sin n\bar{\omega}t dt \quad (\text{B8})$$

where N = the number of segments in the piecewise forcing function. The forcing function in any interval $t_{i-1} \leq t \leq t_i$ is expressed by

$$P(t) = P(t_{i-1}) + \frac{\Delta P_i}{\Delta t} (t - t_{i-1}) \quad (\text{B9})$$

where

$$\Delta P_i = P(t_i) - P(t_{i-1}) \quad (\text{B10})$$

Substituting Equation B9 into Equation B7 and performing the integration gives:

$$a_n = \frac{1}{T_g} \sum_{i=1}^N \left[\Delta t \frac{P(t_i) + P(t_{i-1})}{2} \right] \quad (\text{B11})$$

$$\begin{aligned}
a_n = & \frac{2}{T_g} \sum_{i=1}^N \left\{ \frac{1}{n\bar{\omega}} \left[P(t_{i-1}) - t_{i-1} \frac{\Delta P_i}{\Delta t} \right] (\sin n\bar{\omega}t_i - \sin n\bar{\omega}t_{i-1}) \right. \\
& + \frac{\Delta P_i}{n^2\bar{\omega}^2\Delta t} [(\cos n\bar{\omega}t_i - \cos n\bar{\omega}t_{i-1}) \\
& \left. + n\bar{\omega}(t_i \sin n\bar{\omega}t_i - t_{i-1} \sin n\bar{\omega}t_{i-1}) \right] \Big\}
\end{aligned} \tag{B12}$$

and

$$\begin{aligned}
b_n = & \frac{2}{T_g} \sum_{i=1}^N \left\{ \frac{1}{n\bar{\omega}} \left[P(t_{i-1}) - t_{i-1} \frac{\Delta P_i}{\Delta t} \right] (\cos n\bar{\omega}t_i - \cos n\bar{\omega}t_{i-1}) \right. \\
& + \frac{\Delta P_i}{n^2\bar{\omega}^2\Delta t} [(\sin n\bar{\omega}t_i - \sin n\bar{\omega}t_{i-1}) \\
& \left. + n\bar{\omega}(t_i \cos n\bar{\omega}t_i - t_{i-1} \cos n\bar{\omega}t_{i-1}) \right] \Big\}
\end{aligned} \tag{B13}$$

The response of the SDOF system to a periodic force represented by a Fourier series is the superposition of the response to each component of the series. When the transient is omitted, the total steady state response of a damped SDOF system may be expressed:

$$\begin{aligned}
x_i = & \frac{a_0}{k} + \frac{1}{k} \sum_{n=1}^{\infty} \left[\frac{a_n 2r_n \beta + b_n (1-r_n^2)}{(1-r_n^2)^2 + (2r_n \beta)^2} \sin n\bar{\omega}t_i \right. \\
& \left. + \frac{a_n (1-r_n^2) - b_n 2r_n \beta}{(1-r_n^2)^2 + (2r_n \beta)^2} \cos n\bar{\omega}t_i \right]
\end{aligned} \tag{B14}$$

$$\begin{aligned}
\dot{x}_i = & \frac{1}{k} \sum_{n=1}^{\infty} \left[\frac{a_n 2r_n \beta + b_n (1-r_n^2)}{(1-r_n^2)^2 + (2r_n \beta)^2} (n\bar{\omega}) \cos n\bar{\omega}t_i \right. \\
& \left. - \frac{a_n (1-r_n^2) - b_n 2r_n \beta}{(1-r_n^2)^2 + (2r_n \beta)^2} (n\bar{\omega}) \sin n\bar{\omega}t_i \right]
\end{aligned} \tag{B15}$$

and

$$\ddot{x}_i = \frac{1}{k} \sum_{n=1}^{\infty} \left[-\frac{a_n 2r_n \beta + b_n (1-r_n^2)}{(1-r_n^2)^2 + (2r_n \beta)^2} (n\bar{\omega})^2 \sin n\bar{\omega}t_i \right. \\ \left. - \frac{a_n (1-r_n^2) - b_n 2r_n \beta}{(1-r_n^2)^2 + (2r_n \beta)^2} (n\bar{\omega})^2 \cos n\bar{\omega}t_i \right] \quad (\text{B16})$$

where

$$r_n = \frac{n\bar{\omega}}{\omega}$$

REPORT DOCUMENTATION PAGE

Form Approved
OMB No. 0704-0188

Public reporting burden for this collection of information is estimated to average 1 hour per response, including the time for reviewing instructions, searching existing data sources, gathering and maintaining the data needed, and completing and reviewing the collection of information. Send comments regarding this burden estimate or any other aspect of this collection of information, including suggestions for reducing this burden, to Washington Headquarters Services, Directorate for Information Operations and Reports, 1215 Jefferson Davis Highway, Suite 1204, Arlington, VA 22202-4302, and to the Office of Management and Budget, Paperwork Reduction Project (0704-0188), Washington, DC 20503.

1. AGENCY USE ONLY (Leave blank)		2. REPORT DATE December 1997	3. REPORT TYPE AND DATES COVERED Final report	
4. TITLE AND SUBTITLE Accuracy of Response of Single-Degree-of-Freedom Systems to Ground Motion			5. FUNDING NUMBERS WU 33011	
6. AUTHOR(S) Robert M. Ebeling, Russell A. Green, Samuel E. French				
7. PERFORMING ORGANIZATION NAME(S) AND ADDRESS(ES) See reverse			8. PERFORMING ORGANIZATION REPORT NUMBER Technical Report ITL-97-7	
9. SPONSORING/MONITORING AGENCY NAME(S) AND ADDRESS(ES) U.S. Army Corps of Engineers Washington, DC 20314-1000			10. SPONSORING/MONITORING AGENCY REPORT NUMBER	
11. SUPPLEMENTARY NOTES Available from National Technical Information Service, 5285 Port Royal Road, Springfield, VA 22161.				
12a. DISTRIBUTION/AVAILABILITY STATEMENT Approved for public release; distribution is unlimited.			12b. DISTRIBUTION CODE	
13. ABSTRACT (Maximum 200 words) <p>This technical report summarizes an assessment of the accuracy of six numerical step-by-step procedures used in computational structural dynamics. The results provide quantitative guidance on how the accuracy of these procedures is affected by the time-step and the ground motion frequency characteristics.</p> <p>The six procedures evaluated in this study are representative of the different types of numerical algorithms used to compute the dynamic structural response to a time-dependent loading. The time-dependent loading is expressed in terms of a ground acceleration time-history. The dynamic structural response for each structural model is characterized by the computed response time-histories of accelerations, velocities, and displacements.</p> <p>Using single-degree-of-freedom (SDOF) models with natural periods assigned based on consideration of the important modal periods of hydraulic structures, an evaluation is made of the accuracy of the computed responses at regular time increments during ground shaking. A ground acceleration applied at the base of an SDOF system is equivalent to a fixed-base SDOF system with the forcing function applied to the mass. The results show a correlation between the accuracy of the six numerical step-by-step procedures with the time-step value and frequency characteristics of the ground motion used in the analyses. The six algorithms included in this study are the Newmark β method (with values</p> <p style="text-align: right;">(Continued)</p>				
14. SUBJECT TERMS Earthquake engineering Numerical methods Time domain dynamic analysis Hydraulic structures Structural dynamics			15. NUMBER OF PAGES 89	
			16. PRICE CODE	
17. SECURITY CLASSIFICATION OF REPORT Unclassified	18. SECURITY CLASSIFICATION OF THIS PAGE Unclassified	19. SECURITY CLASSIFICATION OF ABSTRACT	20. LIMITATION OF ABSTRACT	

7. (Concluded).

U.S. Army Engineer Waterways Experiment Station
3909 Halls Ferry Road
Vicksburg, MS 39180-6199

U.S. Defense Nuclear Facilities Safety Board
625 Indiana Avenue, NW, Suite 700
Washington, DC 20004

University of Tennessee at Martin
Martin, TN 38237

13. (Concluded).

of γ and β that correspond to the linear acceleration method), the Wilson θ Method, the Central Difference Method, the 4th-order Runge-Kutta method, Duhamel's integral solved in a piecewise exact fashion, and the piecewise exact method applied directly.

Much of the current guidance for selecting the time-step used in computing dynamic response to ground acceleration is based on studies of the accuracy of numerical methods for computing free vibration response of undamped SDOF systems. The information from the free vibration studies is often combined with useful, but *qualitative*, reference to the frequency characteristics of the forcing function. The time-step criteria for a specified level of accuracy are often expressed as a fraction of the natural (undamped) period of the SDOF system. This report *quantifies* how the accuracy of the six numerical step-by-step procedures is affected by the time-step and the ground motion frequency characteristics.