

AG
JK

New Text Document.txt

14 January 1998

This paper was downloaded from the Internet.

Distribution Statement A: Approved for public release;
distribution is unlimited.

POC: Air Force Space Command

DATE: 22 April 1996

19980121 082



AFSPCHOI

"Series Number"

10-1

**BY ORDER OF THE COMMANDER
AIR FORCE SPACE COMMAND**

22 April 1996

Operations

MISSION NEEDS AND OPERATIONAL REQUIREMENTS

GUIDANCE AND PROCESSES

This Air Force Space Command (AFSPC) Headquarters Operating Instruction (HOI) implements Air Force Policy Directive (AFPD) 10-6, Mission Needs and Operational Requirements Use Agreements, by providing guidance and procedures for developing and processing AFSPC mission needs and operational requirements. It defines and delineates responsibilities for developing and processing Mission Need Statements, Operational Requirements Documents, Cost and Operational Effectiveness Analysis, and North American Aerospace Defense Command Mission Need Statements, entrenches the Concept Action Group philosophy; empowers Command Leads; and specifies training for participants in the AFSPC requirements process. This HOI applies to HQ AFSPC.

SUMMARY OF REVISIONS

This revision aligns the instruction with AFPD10-6, AFI10-601, Mission Needs and Operational Requirements Guidance and Procedures, and the Department of Defense Instruction (DoDI) 5000 series; and incorporates policy and process changes resulting from headquarters reorganizations and the addition of a new requirements review council, the Air Force Requirements Oversight Council (AFROC).

1. The Requirements Process. Requirements Generation:

1.1. The operational requirements process provides AFSPC the means to identify operational deficiencies, to state operational needs, and to initiate the development of improvements to systems or equipment.

1.2. Mission requirements evolve from a strategy-to-task methodology. The Under Secretary of Defense for Acquisition and Technology [USD(A&T)], also known as the Defense Acquisition Executive (DAE), specifies mission areas that require development of new technologies and capabilities to meet mission deficiencies identified by the Services.

1.3. Each Service uses the Mission Area Assessment (MAA) to identify specific capabilities needed to attain specific strategic objectives in order to meet the President of the United States National Security Strategy (NSS), Secretary of Defense Defense Planning Guidance (DPG) and subsequent Chairman of the Joint Chiefs of Staff (CJCS) National Military Strategy (NMS). This process is called "Strategy-to-task." The Air Staff and the Major Command (MAJCOM) study

DTIC QUALITY INSPECTED 3

their assigned mission in the context of the respective MAJCOM Concept of Operations (CONOPS). From this assessment, the MAJCOMs list individual tasks they must complete in support of their mission and documents this in the MAA.

1.4. The Mission Needs Analysis (MNA) is conducted by the Command and focuses on the tasks identified by USAF and the MAJCOM in the Mission Area Assessment and capability of the Command to perform these tasks. This process is called "task-to-need." The MAA/MNA process identifies mission deficiencies or needs first expressed in broad, operational terms related directly to an assigned task, role, or mission that cannot be performed efficiently. Operating MAJCOMs will first assess nonmateriel solution to satisfy a mission area deficiency. These solutions may include changes in training, tactics, doctrine, and strategy. After considering all nonmateriel options, MAJCOMs then consider a materiel solutions and develop a Mission Need Statement (MNS). The command identifies, defines, and validates a specific operational need in a Mission Need Statement (MNS).

1.5. The MNS is the basic Department of Defense (DoD) document to record a deficiency requiring a materiel (new hardware or software) solution. It must be comprehensive enough to convey the concept, yet concise enough to describe the requirement in no more than five pages of text. The MNS provides AFSPC with the means to formally enter the USAF Program Objective Memorandum (POM) and Biennial Planning, Programming, and Budgeting System (BPPBS) process, request supporting data from the implementing commands, and ask for HQ USAF and all MAJCOM review and comment. Appropriate AFSPC MNSs are reviewed by the Air Force Requirements Oversight Council (AFROC), validated by the Joint Requirements Oversight Council (JROC), and approved by the Chief of Staff of the Air Force (CSAF).

1.6. Unified Commands and the Joint Staff state their operational requirements in a MNS for review and validation by the JROC. The MNS is a top-level basic need document, written by one or more commander-in-chief (CINC), to identify a warfighting mission need and/or deficiency. It is validated by the JROC, approved by the DAE or his military department counterpart and assigned to the appropriate service(s) for action. AFSPC, in its role as a component of United States Space Command/United States Strategic Command (USSPACECOM/USSTRATCOM), reviews all USSPACECOM/USSTRATCOM MNS prior to review and validation by the JROC. A USSPACECOM/USSTRATCOM MNS may be a capstone document which requires a subsequent MNS be developed by one or more of the component commands. If a component command is not required and the Air Force is selected as lead service, HQ USAF/XOR will issue the Program Management Directive (PMD) for Phase 0, Concept Exploration and Definition.

1.7. A North American Aerospace Defense Command (NORAD) MNS (N-MNS) is written to describe and validate NORAD operational needs. The binational process requires the direct involvement of the Canada -United States Military Cooperation Committee, the Joint Staff, Canadian Air Command, and the Air Staff. A validated N-MNS is considered coequal to an Air Force MNS and processed accordingly by the JROC.

1.8. Validated HQ USAF or MAJCOM MNS compete for funds in the AFSPC POM process (see SR 27-1, Air Force Space Command Programming System), the USAF POM, and eventually in the President's budget. Existence of a MNS does not ensure funding; however, the lack of a validated MNS will likely ensure no funding.

1.9. The modification and upgrade process is used to correct deficiencies, provide new or improved capabilities for existing weapon and support systems, reduce the cost of ownership, or remove capabilities which are no longer needed. "Modification" is a change to a system (whether for safety, to correct a deficiency, or to improve performance) that is still be produced. "Upgrade" is a change to a system (whether for safety, to correct a deficiency, or to improve performance) that is out of production. Modifications under \$10 million (current year \$) and temporary and approved safety modifications will use the AF Form 1067, Modification Proposal, in lieu of a MNS and Operational Requirements Document (ORD). Command, control, communications, computers (C4) systems acquired or modified under AFD 33-1 and costing less than \$5 million

will use the AF Form 3215, Communication/Computer Systems Requirement Document (CSRD) in lieu of a MNS.

1.10. If the operational need successfully competes for funds, HQ USAF/XOR issues a studies PMD to initiate concept exploration. This PMD which directs Phase 0 activities is referred to as the "concept studies" PMD. The concept studies PMD directs the operating command to lead the effort, identify, explore, and evaluate a specific number of potential alternative solutions, then prepare an extensive Cost and Operational Effectiveness Analysis (COEA) of each of the candidate solutions for Acquisition Category (ACAT) I level programs. The Milestone Decision Authority (MDA) may require a COEA for ACAT II, III, IV level programs or may require a less extensive, tailored, Cost Benefit Analysis (CBA). SAF/AQX issues the PMDs after successful conclusion of milestone I. These PMDs are used to change, transition, or terminate programs. PMDs are used to provide specific guidance to the implementing, supporting, and operating commands. The content of a PMD, including the required HQ USAF review and approval actions, is tailored to each individual program.

1.11.A CONOPS describes the approach to deploying, employing, and operating new or upgraded systems or capabilities which are being advocated to meet identified tasks or missions. It can address a single system or family of systems involving multiple systems, MAJCOMs or services. HQ AFSPC/DO is responsible for the development of mission area and system specific CONOPS discussing the deployment and operations of AFSPC systems. CONOPS development begins after the MNS is validated and approved. The CONOPS will be refined throughout the acquisition process.

1.12. Together the MNS, threat assessment, and the CONOPS form the basis of the COEA. The COEA is an analysis of the estimated costs and operational effectiveness of alternative materiel systems to meet a mission need and the associated program for acquiring, employing, deploying, and sustaining each alternative. The COEA allows the commander to compare possible solutions on the basis of the cost versus operational effectiveness. The COEA will be refined throughout the acquisition process.

1.13. Once a need is validated, funded for pre-Milestone I studies, a PMD is issued, and alternatives compared in a COEA, the program requirements are further defined in an Operational Requirements Document/Requirements Correlation Matrix (ORD/RCM). The ORD/RCM is a MAJCOM-generated requirements document. Its purpose is to amplify and refine operational and support needs as stated in a validated MNS and CONOPS. The ORD/RCM defines the requirements of the alternative which is the preferred solution emerging from the COEA. The ORD/RCM is distributed for review and comment per AFI 10-601, comments are resolved, the ORD/RCM is reviewed by AFROC and/or JROC for major programs, and is approved by the CSAF. Approval may be delegated by CSAF, as appropriate.

1.14. An Acquisition Program Baseline (APB) is the formal agreement between the implementing command and the MDA for each program. The APB governs the activities of the implementing command in the succeeding phase in which it is developed. The initial APB, called the "Concept APB", is developed by the Air Force Materiel Command (AFMC) cadre in Phase 0 for use in Phase 1. The operating MAJCOM coordinates on the APB before it is signed. The Policy and Process Office, DRR, processes all APBs coming through AFSPC. Process all APBs as described in paragraph 4.5.

1.15. Acquisition categories in which operational requirements are placed determine the level of decision authority. Relying on recommendations evolving through the Integrated Product Team (IPT) process, the decision authority, in turn, determines the specific documents needed at each milestone and the level of review for the documentation. For example, requirements placed in ACAT I are reviewed by the DAE; those in ACAT II, III, or IV, are reviewed by the Service Acquisition Executive (SAE), although the SAE may delegate decision authority to lower levels. There are four ACAT levels:

1.15.1. ACAT ID (Defense). \$300 million (FY90 dollars) Research Development Test & Evaluation (RDT&E) or \$1.8 billion (FY90 dollars) Procurement/Production (Office, Secretary of Defense (OSD) Approval).

1.15.2. ACAT IC (Component). \$300 million (FY90 dollars) RDT&E or \$1.8 billion (FY90 dollars) Procurement/Production (Service Approval).

1.15.3. ACAT II. \$115 million (FY90 dollars) RDT&E or \$540 million (FY90 dollars) Procurement/Production.

1.15.4. ACAT III. Less than above, but designated by the SAE.

1.15.5. ACAT IV. All other programs.

1.16. Refer to the Command Managers Guide (CMG) and AFI10-601 for more detailed information on the requirements process. Figure 1 provides a pictorial overview of the requirements process.

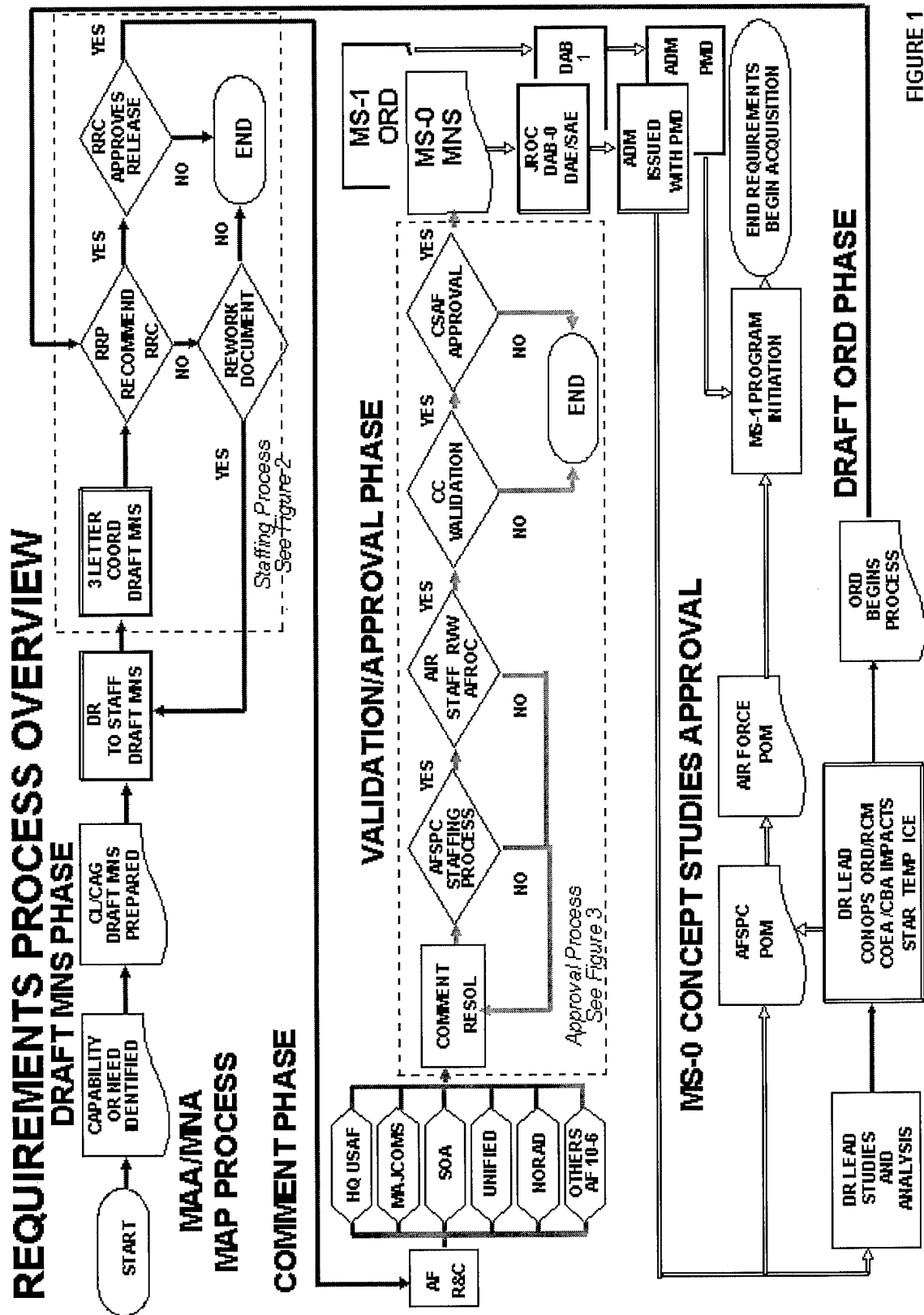

FIGURE 1

2. **Directorate Responsibilities.** In accordance with DoDI 5000 series and Air Force Supplement 1, DoDI 5000.2, AFPD 10-6, and AFI 10-601, operating commands are responsible for determining, documenting, coordinating and reviewing user requirements. AFSPC will submit

requirements documents for validation and approval; manage concept studies and COEA activities; coordinate efforts with implementing commands and agencies; and, when directed, brief requirements during AF Council deliberations, Summits, SAF/AQ Integrated Process Team meetings, AFROC, JROC, Defense Acquisition Board (DAB) Overarching Integrated Product Team (OIPT) meetings, and Defense Acquisition Board milestones.

2.1. HQ AFSPC Director of Plans (XP). XP is responsible for Mission Area Planning (MAP) and:

2.1.1. Reviews all requirements documents (MNSs, ORD/RCMs, COEAs, etc) and provides written comments when appropriate.

2.1.2. Conducts strategy-to-task (STT) and task-to-need (TTN) processes in accordance with AFSPC guidance to produce MAA, MNA, and MAP.

2.1.3. Ensures a Manpower Estimate Report (MER) and Integrated Manpower, Personnel, and Comprehensive Training and Safety (IMPACTS) document are developed.

2.1.4. Updates agreements, as required, with foreign countries.

2.1.5. Ensures visitor requests are processed for visits to foreign countries.

2.1.6. Reviews MNS, ORD/RCMs, and CONOPS for foreign involvement and releasability issues. Additionally, XP has command oversight for the development of applicable Delegation of Disclosure Authority Letters (DDLs).

2.1.7. Verifies that funding is programmed for approved requirements.

2.2. HQ AFSPC Director of Requirements (DR). HQ AFSPC/DR is responsible for developing and processing all appropriate AFSPC requirements documents (paragraphs 4.1.-4.3.) and:

2.2.1. Responsible for the development and management of the Command Management Program for operational requirements.

2.2.2. Will manage an operational requirements training program in the Policy and Process Office (DRR).

2.2.3. Will designate a Command Lead (CL) in writing at the conclusion of mission area planning activities and when AFSPC identifies a mission deficiency which requires a materiel decision.

2.2.4. HQ AFSPC/DR, as the command focal point for requirements documentation processes, is the execution agency for the Requirements Review Panel (RRP) and the Requirements Review Council (RRC), (see paragraphs 3.4. and 3.5.). In addition, HQ AFSPC/DR reviews and coordinates the approval process of requirements documents (MNS and ORD/RCM).

2.2.5. AFSPC/DR transfers responsibility to AFSPC/DO for those delivered systems that are the operational responsibility of AFSPC/DO.

2.3. HQ AFSPC Director of Operations (DO). HQ AFSPC/DO is responsible for the development of conceptual documents and the following:

2.3.1. Providing a Concept Action Group (CAG) member who will be responsible for the tasks listed in paragraphs 2.3.2 thru 2.3.6. This member supports and participates in all CAG activities.

2.3.2. Assessing current capabilities against the threat assessment to determine if non-materiel solutions will satisfy the need (i.e., change in training, doctrine, or tactics).

2.3.3. Developing employment concepts and tactics, mission planning requirements and weapon system capabilities and military characteristics to support the mission area.

2.3.4. Developing all CONOPS.

2.3.5. Reviewing all operational requirements documents and providing written guidance when appropriate.

2.3.6. Reviewing and approving AFSPC testing and evaluation policy, guidance and oversight to include the Test and Evaluation Master Plan (TEMP).

2.3.7. Assuming responsibility for those delivered systems that are the operational responsibility of HQ AFSPC/DO and designating a Program Element Monitor (PEM) in the appropriate area within AFSPC.

2.3.7.1. HQ AFSPC/DO certification is required before assignment as a HQ AFSPC/DO/PEM.

2.3.7.2. The HQ AFSPC PEM manages all modifications under \$10 million total costs (1990 dollars). Modifications over \$10 million will be referred by the PEM to HQ AFSPC/DR for documentation and approval in a MNS and initiation of Phase 0 activities.

2.3.7.3. Through the modifications ranking board, the PEM prioritizes all system modifications and will allocate future year procurement funds (3010, 3020, 3080) based on established priorities.

2.3.8. Determining requirements for Initial Operating Capability (IOC) and documenting these requirements in the ORD/RCM. The process for declaring IOC is defined in AFSPCI 10-2.

2.3.9. Ensuring training requirements are documented in the System Training Plan and through conduct of the Training Planning Teams.

2.4. HQ AFSPC Director of Financial Management and Comptroller (FM):

2.4.1. Provides a CAG member who will be responsible for the tasks listed in paragraphs 2.4.2. and

2.4.3. This member supports and participates in all CAG activities.

2.4.2. Is responsible for the coordination and development of cost estimates used in the COEA. This responsibility includes the acquisition and operating and support (O&S) costs estimates for the defined baseline and alternatives.

2.4.3 Is responsible for reviewing all operational requirements documents for FINANCIAL CONTENT and providing written guidance when appropriate.

2.5. HQ AFSPC Director of Intelligence (IN):

2.5.1. Provides a CAG member who will be responsible for the tasks listed in paragraphs 2.5.2. thru

2.5.5. This member supports and participates in all CAG activities, especially those related to COEAs.

2.5.2. Provides threat estimates and impacts on AFSPC operating systems or equipment. HQ AFSPC/ DR and HQ AFSPC/DO will consult with IN on recommendations for self protection suites on AFSPC systems, based on the nature of the threat. Estimates will include the projected threats at system IOC, as well as at system mid-life (IOC+10). The scope of the estimates will include ground, naval, and aerospace-based threats.

2.5.3. Reviews and provides inputs to the System Threat Assessment Report (STAR) - ACAT I/ System Threat Assessment (STA) - ACATs II-IV, and represents the command at threat steering groups related to the command system acquisition program.

2.5.4. Appoints an Intelligence Counterpart Officer (ICO) for selected major weapon systems. The ICO is appointed prior to MS-0, during need establishment, and provides input to the MNS. The ICO will actively participate in all HQ AFSPC/DO/DR/XP requirements discussions, and subsequent planning and programming actions. Responsibilities of the ICO include the formation of an Intelligence Support Working Group (ISWG) immediately after MS-0. The ISWG will assist the using command in building the Intelligence Support Plan (ISP). Once coordinated and approved by USAF/IN, the ISP forms the baseline for providing intelligence infrastructure support to a program throughout its life cycle.

2.5.5 Is responsible for reviewing all operational requirements documents and providing written guidance when appropriate.

2.6. HQ AFSPC Director of Logistics (LG):

2.6.1. Provides a CAG member who will be responsible for the tasks listed in paragraphs 2.6.2 thru

2.6.4. This member supports and participates in all CAG activities.

2.6.2. Provides the System Program Office's (SPO) with AFSPC logistics support requirements to field and maintain a weapon system. This support includes: maintenance concepts, maintenance support, test and support equipment, maintenance training, reliability, maintainability, and availability, technical data, supply support, manpower, configuration management, funding, testing, and acceptance.

2.6.3. Is the point of contact for Integrated Logistics Support Plan (ILSP), Logistics Support Analysis (LSA), and Master Plan (MP) documents involving new acquisition efforts.

2.6.4 Is responsible for reviewing all operational requirements documents and providing written guidance when appropriate.

2.6.5. Is responsible for the development of command logistics policy.

2.7. HQ AFSPC Directorate of The Civil Engineer (CE) Responsibilities.

2.7.1. Will provide a CAG member who will be responsible for the tasks listed in paragraphs 2.7.2 through 2.7.6. This member supports and participates in all CAG activities.

2.7.2. Is responsible for Military Construction (MILCON) and military construction feasibility statements.

2.7.3. Is responsible for all facility construction or modification requirements.

2.7.4. Is responsible for the Environmental Impact Analysis Process (EIAP).

2.7.5. Is responsible for environmental compliance and concerns to include the development of a Pollution Prevention Program (P3).

2.7.6. Is responsible for reviewing all operational requirements documents and providing written guidance when appropriate.

2.8. HQ AFSPC Director of Communications/Computer Systems (SC):

2.8.1. Will provide a CAG member who will be responsible for the tasks listed in paragraphs 2.8.2. through 2.8.11. The member of the CAG will participate in all CAG activities and will:
2.8.1.1. Provide to the CAG, life-cycle costs associated with communications and computer systems required to complete the COEA.

2.8.1.2. Provide to CAG members, communications and computer expertise required to complete the various documents required for each life-cycle phase, such as Manpower Estimate Reports, Integrated Logistics Support Plans, or Computer Resources Life Cycle Management Plan (CRLCMP).

2.8.2. Completes all documentation required to obtain communications and frequency support during pre milestone 0 and phases 0 through III. Coordinates documentation with the appropriate program management offices.

2.8.3. Ensures the systems integration, interoperability, and integrity of the Integrated Tactical Warning and Attack Assessment (ITW/AA) System comprised of the following mission areas: missile warning, communications, intelligence, space warning, space control, and air warning. This includes all dedicated and contributing systems. HQ AFSPC/SC performs the function of the Systems Level Integrator and Systems Level Engineer for the entire ITW/AA as directed by the USSPACECOM ITW/AA System Management Directive.

2.8.4. Ensures the integration, interoperability, and integrity of C⁴ systems supporting Satellite Control, Intercontinental Ballistic Missile (ICBM), Spacelift Range and AFSPC base-level infrastructure.

2.8.5. Directs the operation and maintenance of communications computer systems and assists in the development of CONOPS, mission area CONOPS, and deployment/employment for these systems.

2.8.6. Is responsible for the management of all resources supporting communications and computer systems. For HQ AFSPC/SC programs, HQ AFSPC/SC will appoint a PEM.

2.8.7. Identifies the communications and computer requirements required by the MNS, ORD/RCM, and the acquisition documents. Provide to other CAG members required communications and computer technical support. Provides membership to the Computer Resources Working Group (CRWG) when that working group is established by the SPO.

2.8.8. Develops and maintains the communications-computer architecture plans.

2.8.9. Identifies and maintains a list of communications and computer standards that will be applied across all systems.

2.8.10. Standardizes communications and computer maintenance concepts for all systems.

2.8.11. Is responsible for reviewing all operational requirements documents and providing written guidance when appropriate.

2.9. HQ AFSPC Director of Security (SP):

2.9.1. Will provide a CAG member who will be responsible for the tasks listed in paragraphs 2.9.2 through 2.9.6. This member supports and participates in all CAG activities.

2.9.2. Coordinates on security priority designation packages for AFSPC priority resources. Determines the requirements for priority resource protection.

2.9.3. Is responsible for providing physical, industrial, personnel, information and product security guidance over the life cycle of the system.

2.9.4. In the requirements process, HQ AFSPC/SP is the office of primary responsibility (OPR) for interface and coordination with Electronic Security Center (ESC) when acquiring new security systems.

2.9.5. Is responsible for reviewing all operational requirements documents, mission needs statements, and providing written guidance when appropriate.

2.9.6. Provides all security support requirements to deploy and employ weapons systems. Support includes security manpower, sensors (alarms), and other requirements.

2.10. HQ AFSPC Director of Safety (SE):

2.10.1. Will provide a CAG member who will be responsible for the tasks listed in paragraphs 2.10.2 through 2.10.5. This member supports and participates in all CAG activities.

2.10.2. Provides direction and recommendation for policy implementation of safety reporting.

2.10.3. Is the point of contact for all safety concerns.

2.10.4. Is responsible for reviewing all operational requirements documents and providing written guidance when appropriate.

2.10.5. Participates in the IMPACTS planning process.

2.11. AFSPC Space Warfare Center (SWC):

2.11.1. Provide support to the CL and HQ AFSPC/DR in the development of requirements.

2.11.2. Provide input into defining requirements with respect to providing space support to the warfighter.

2.11.3. Support CAG activities by matching Combat Air Forces (CAF) requirements with programs which may be able to accomplish the CAF requirement.

2.11.4. Provide guidance on warfighter requirements to AFSPC/DR and XP that helps shape future space systems.

2.12. Other HQ AFSPC Staff OPRs:

2.12.1. Provide support to the CL and HQ AFSPC/DR in their area of functional expertise. 2.12.2. Support CAG activities by developing sections of each requirements document as requested. Assist the document OPR in staff actions within their Directorate.

3. Other Organizational Responsibilities:

3.1. HQ AFSPC Policy and Process Office (DRR):

3.1.1. Is Command point of contact for policies, procedures and guidance for implementation of the DoDI 5000 series, AFI 10-601 and AF Supplement 1.

3.1.2. Logs in, assigns numbers, and maintains all requirements and related documents, including PMDs and APBs in HQ AFSPC for review, comment, coordination, approval, or validation.

3.1.3. Chairs the RRP.

3.1.4. Maintains a listing of all assigned command leads and CAGs.

3.1.5. Manages the operational requirements training program to include:

3.1.5.1. Identification of training sources.

3.1.5.2. Management of quotas.

3.1.5.3. Development of training curriculum.

3.1.5.4. Tracking of CL training and certification.

3.1.6. Submits a Command certification list of valid requirements semiannually to HQ USAF as required by AFI10-601.

3.1.7. Develops and maintains standard briefing formats for RRP, RRC, AFROC, and JROC briefings.

3.1.8. Provides guidance for internal coordination and review.

3.1.9. Is the single point of contact for distributing documents for USAF wide review and comment.

3.1.10. Maintains a library of all AFSPC MNSs and ORD/RCMs.

3.1.11. Will serve as the single Point of Contact (POC) for assigning OPRs for review and comment of externally generated requirements documents. Once assigned to the appropriate division, that division OPR is responsible for staffing and reconciling comments pertaining to the document. When OPR completes staffing, DRR will review prior to DR signing out package. Documents include MNSs, ORD/RCMs, N-MNS, PMDs and APBs.

3.1.12. Single operational requirements point of contact within HQ AFSPC for non-program specific liaison with outside agencies.

3.1.13. Other DR divisions are assigned appropriate external requirements documents to staff by DRR. Actions in the staffing process include issuing tasking letters, collecting comments, consolidating appropriate responses, obtaining coordination from the functional OPR of the response, and preparing the final product to complete the tasking. For APBs and MNS, this is typically a staff summary sheet and a letter for signature. For PMDs, N-MNS, and other MAJCOM MNS and ORD/RCMs, this is typically a letter to the agency requesting the review and/or coordination for signature at the appropriate level. Final packages are prepared for DR signature and processed through DRR.

3.2. HQ AFSPC/DR Command Lead (CL):

3.2.1. Is the Command focal point for the processing of requirements and related documents described in this HOI.

3.2.2. The Command Lead will be certified by AFSPC/DR upon completion of his/her core training. Substitution of training requirements may be granted by approval from HQ AFSPC/DR. Submit requests for substitution and waivers to HQ AFSPC/DR. In addition to mandatory training below, HQ AFSPC/DR may require optional training be accomplished, as required. Optional training, such as just-in-time training may be keyed to specific tasks to be performed, for example, COEA Study Director Training. The DR/CL will have the following mandatory training completed within 6 months of appointment:

3.2.2.1. SYS 111 Operational Requirements Process.

3.2.2.2. Command Management Seminar (CMS).

3.2.2.3. Space and Missile Basic Applications Course.

3.2.2.4. Ethics Seminar.
3.2.2.5. HQ AFSPC Action Officers Course.

3.2.2.6. POM School.

3.2.2.7. PEM School.

3.2.3. Upon assignment of a program, the CL will form a Concept Action Group (CAG) to fulfill the responsibilities of the Command. The CL, through effective use of the CAG, will conduct or oversee all activities leading to Milestone 0 (MS-0) and Milestone-I (MS-I) to include development of the MNS, ORD/RCM, and COEA; coordination of all other documentation required for the AF Council, SAF/AQ Integrated Process Team, AFROC, JROC, Summit or Defense Acquisition Board (DAB); and as directed by a Concept Studies PMD (see paragraph 1.10.) and follow-on PMDs. The CL:

3.2.3.1. Coordinates strategy for Phase 0, Concept Exploration and Definition, and a draft PMD, in preparation for MS-0.

3.2.3.2. Prepares initial documentation and advocacy to support the BPPBS and POM.

3.2.3.3. Directs the preparation of MS-1 requirements documentation.

3.2.3.4. Is the focal point to ensure the integration, interoperability, and standardization of Command operational requirements.

3.2.4. Working with the CAG prepares the MNS in accordance with (IAW) AFI 10-601 and staffed per procedures established by HQ AFSPC/DRR and this HOI. These procedures are outlined in paragraph 4.1. Is responsible for coordinating and processing MNS within AFSPC.

3.2.5. Working with the CAG prepares the COEAs and CBAs IAW AFI 10-601. Is responsible for coordinating and processing COEAs and CBAs within AFSPC per this instruction paragraph 4.3.

3.2.6. Is responsible for ensuring both the MNS and CONOPS are used as the foundation of the COEA.

3.2.7. Is responsible for coordinating and processing ORD/RCMs within AFSPC. The staffing procedures for an ORD/RCM are outlined in paragraph 4.2 of this HOI.

3.2.8. Is responsible for resolution of all comments on AFSPC generated documents and keeps a written record of all comments and resolutions. Maintains a copy of all comments, their resolution, and the revised document for DR or DRR review at each stage in the staffing process.

3.2.9. Reviews all requirements and acquisition documents to ensure each Directorate has comprehensively addressed both functional and technical integration, interoperability, and standardization aspects.

3.2.10. Maintains a program timeline checklist to help keep track of program status.

3.2.11. Schedules, prepares and presents all required prebriefs, RRP, RRC, AFROC, JROC, and Command briefings per HQ AFSPC/DRR guidance. Takes and distributes RRP and RRC minutes.

3.3. Concept Action Group (CAG). Is an action officer working-level group which contains sufficient functional area expertise to produce requirements documents; primarily the MNS, COEA, and ORD/RCM, as well as any other documentation required by the PMD. It is chaired by the CL.

3.3.1. The CAG also participates as necessary in the review of all other requirements documents as required in the PMD.

3.3.2. DR tasks each directorate to provide a representative for the CAG. Members are appointed by letter from their directorate and these letters are maintained by the CL. All appropriate areas of the staff should be represented and participate. Outside support (user, acquisition, training, testing, etc.) for CAG activities may also be required. The membership will change as the program works through the acquisition cycle.

3.3.2.1. During the formation of a CAG the CL will address the upcoming program activities (i.e. MNS development, ORD/RCM development, etc.) and corresponding training requirements needed by CAG members. This may include a review of training received by each member and determining which training would be value added in the performance of the CAG duties. The CL and individual CAG members will determine if job experience should take the place of any formal training. Some available training includes, but is not limited to:

3.3.2.1.1. Command Management Seminar.

3.3.2.1.2. Air Force Operational Requirements Process (SYS 111).

3.3.2.1.3. Space & Missile Basic Applications Course.

3.3.2.1.4. Quality Air Force Team Building.

3.3.2.1.5. Fundamentals of Systems Acquisition Management (ACQ 101).

3.3.2.1.6. COEA Orientation Training.

3.3.2.1.7. Just-in-Time Training (see paragraph 5.3).

3.3.2.1.8. POM School.

3.3.2.1.9. PEM School.

3.3.2.2. Directors should insure that their appointed CAG representatives have received the training required to perform their CAG duties. Each CAG member will have received or be scheduled for Command Management Seminar and Ethics training.

3.3.3. The CAG remains active until the system is operational. CAG members are encouraged to keep their chain of command informed of all activities.

3.3.4. If the CAG cannot arrive at a resolution of an issue during deliberations, the issue is documented then brought to the RRP or RRC for resolution.

3.4. Requirements Review Panel (RRP).

3.4.1. Functions as a division-level requirements reviewing body and as an advisory board to HQ AFSPC/DR. Approval by the RRP serves as formal division-level coordination for each requirements document briefed. A staff summary sheet (SSS) should be used for coordination in lieu of an RRP if no significant issues exist with requirements documentation. A determination is made by the CL.

3.4.2. Evaluates each requirement presented to it and makes a recommendation to the HQ AFSPC/DR as to the document's disposition. The RRP may recommend:

3.4.2.1. Proceeding to the next step in the approval process.

3.4.2.2. Resolving specific issues before the document proceeds.

3.4.2.3. Terminating the effort altogether.

3.4.2.4. Sending issues which cannot be resolved to the RRC for resolution.

3.4.3. DRR is the chair of the RRP. The OPR for conduct and scheduling of the RRP is the program CL's division. Members of the RRP are division chiefs. Attendees are expected to be able to speak for their division during deliberations and make appropriate recommendations. Determination of a working quorum is at the discretion of the chair. The CL is responsible for notifying the RRP members, when announcing the meeting, that absence from the meeting is implied as coordination of the document.

3.4.4. The office symbols listed below constitute the RRP and should be put on distribution for correspondence circulated for internal three letter review. The quantities indicated after the office symbols are provided to that agency for its directorate's distribution and coordination. Addressees are responsible for complete coordination within their respective directorate. Unless otherwise specified, each office receives one copy.

3.4.4.1. HQ AFSPC/DR, Directorate of Requirements.

3.4.4.2. HQ AFSPC/CEP, Programs Division.

3.4.4.3. HQ AFSPC/DRC, Space Control Division.

3.4.4.4. HQ AFSPC/DRF, Force Enhancement Division.

3.4.4.5. HQ AFSPC/DRM, Missile Systems Requirements Division.

3.4.4.6. HQ AFSPC/DRR, Policy and Process Office.

3.4.4.7. HQ AFSPC/DRS, Space Support Division.

3.4.4.8. HQ AFSPC/DOX, Operational Plans Division (5 copies).

3.4.4.9. HQ AFSPC/FMA, Financial Analysis Division.

3.4.4.10. HQ AFSPC/INX, Intel Plans and Policy Division.

3.4.4.11. HQ AFSPC/LGX, Logistics Plans Division (5 copies).

3.4.4.12. HQ AFSPC/SCM, Systems Management Division (5 copies).

3.4.4.13. HQ AFSPC/SEC, Space Safety Division.

3.4.4.14. HQ AFSPC/SPX, Plans and Programs Division.

3.4.4.15. HQ AFSPC/SWC/XRC, Programs and Resources Division.

3.4.4.16. HQ AFSPC/XPX, Plans Division (3 copies).

3.4.4.17. 14AF/DO, Fourteenth Air Force.

3.4.4.18. 20AF/DO, Twentieth Air Force.

3.5. Requirements Review Council (RRC). The RRC is a Directorate-level requirements review body. The RRC meets at the request of the chairperson or an RRC member to coordinate and discuss and resolve issues which cannot be resolved at a lower level. The RRC meets to review requirements documents before release for MAJCOM and Air Staff review and before validation or approval. A staff summary sheet should be used for coordination in lieu of an RRC if no

significant issues exist with requirements documentation after the RRP review. A determination is made by HQ AFSPC/DR.

3.5.1. The RRC may recommend:

3.5.1.1. Release of the document for AF-wide or AFROC review.

3.5.1.2. The Commander's validation or approval by the appropriate Air Force Decision Authority.

3.5.1.3. Approval by the Commander as appropriate. HQ AFSPC Commander (CC) or designated representative nominates AFSPC ACAT I MNSs and ORD/RCMs to HQ USAF/XOR for JROC validation and CSAF approval. HQ AFSPC/ CV validates AFSPC ACAT II, III, and IV MNSs and ORD/RCMs and sends them to HQ USAF/XOR for CSAF approval. 3.5.1.4. Continue in the processing cycle pursuant to incorporating specific guidance.

3.5.1.5. Terminating the effort. 3.5.2. The RRC is chaired by the Director of Requirements or his designated representative. RRC members are listed below. Determination of a working quorum is at the discretion of the Chair. If members are absent from the meeting the CL must walk the SSS thru the absent office(s) for coordination.

3.5.2.1. RRC members:

3.5.2.1.1. HQ AFSPC/DR, Director of Requirements.

3.5.2.1.2. HQ AFSPC/CE, The Civil Engineer.

3.5.2.1.3. HQ AFSPC/DO, Director Of Operations.

3.5.2.1.4. HQ AFSPC/FM, Director of Financial Management and Comptroller.

3.5.2.1.5. HQ AFSPC/IN, Director of Intelligence.

3.5.2.1.6. HQ AFSPC/LG, Director of Logistics.

3.5.2.1.7. HQ AFSPC/SC, Director Of Communications/Computer Systems.

3.5.2.1.8. HQ AFSPC/SP, Director of Security.

3.5.2.1.9. HQ AFSPC/XP, Director of Plans.

3.5.2.1.10. HQ USSPACECOM/J5, Director of Plans.

3.5.2.1.11. NORAD/J5, Director, NORAD Planning Staff.

3.5.2.1.12. Other directorates or organizations as requested by the Chair.

4. HQ AFSPC Requirements Documentation and Processing:

4.1. How to process a MNS. When all members of the CAG have coordinated on the MNS, it will be forwarded to the appropriate division for staffing (see figure 2). All comments received will be resolved by the CL and CAG. The CL updates the MNS as necessary and prepares a comment resolution sheet addressing disposition of every comment received. The MNS is refined until no significant issues remain, or until such time as issues must be resolved by a higher body.

4.1.1. The MNS is ready for the RRP at this time. The CL briefs the RRP. The CL normally schedules the RRP 2 weeks from finalization of the updated document and the comment resolution. The CL writes and distributes the minutes of the RRP. RRP invitees will be required to sign a staff summary sheet signifying division-level concurrence on the document.

4.1.2. Following a successful RRP, an RRC will be scheduled, or, at the discretion of HQ AFSPC/DR, a staff summary sheet for directorate coordination will be initiated.

4.1.2.1. If an RRC is to be held, the CL normally schedules it 2 weeks after a successful RRP or, if the MNS requirements change, no later than 2 weeks after the revised MNS is provided. The CL must pre-brief DRR and DR before the RRC meeting announcement is released. The RRC announcement contains the latest version of the MNS. The CL briefs the RRC. Approval of the MNS by the RRC constitutes Directorate coordination with no outstanding issues. The CL will prepare the minutes of the RRC.

4.1.2.2. If the MNS is uncontentious, the responsible division will prepare a SSS coordinated through HQ AFSPC/DRR, for HQ AFSPC/DR signature, asking for Directorate coordination and release for USAF review.

4.1.3. After the MNS is approved for release for USAF review, the CL prepares a distribution letter for HQ AFSPC/DR signature and distribution to the addressees listed in AFI 10-601 (see figure 3). MNSs ready for USAF wide review and comment will be coordinated through DRR. The CL will provide the document in electronic form to DRR for EMail distribution. DRR will distribute the MNSs by EMail where possible and by mail (paper copy) where EMail is not possible. (EMail distribution can be made up to SECRET level.) Replies to the review and comment will be returned to the CL for resolution.4.1.4. When comments from the USAF review are resolved, the comment originator is informed by the CL of comment disposition and resolved comments are maintained on file. If there are major changes (as determined by DR), the MNS will have to go through an RRP again. If the MNS successfully completes the RRP, it is ready for the final Command review. If there are no major changes to the MNS after the AF-wide review, the MNS proceeds directly to the final Command review and Air Staff reviews.

4.1.5. The responsible division will schedule an RRC in coordination with HQ AFSPC/DRR, or process a staff summary sheet package for coordination. When fully coordinated, HQ AFSPC/DR signs a nomination letter to HQ USAF/XOR requesting final Air Staff coordination.

4.1.5.1. The Air Staff will schedule an AFROC for final review of ACAT I and designated programs' MNSs. The AFROC assists the Deputy Chief of Staff (AF/XO), the Vice Chief of Staff of the Air Force (VCSAF), and the CSAF in their responsibilities to assess AF operational requirements (these requirements should be linked to the national military strategy). Another function of the AFROC is to oversee mission need determination and the requirements generation process. The AFROC performs mission need reviews and recommends CSAF approval prior to the start of the acquisition cycle. The AFROC specifically reviews the identified deficiency in the MNS, ensures that a nonmateriel solution is not feasible, ensures potential materiel solutions are explored in accordance with the DoD 5000.1 directed hierarchy, and that operational constraints are documented.

4.1.5.1.1. The Director of Operational Requirements (AF/XOR) chairs the AFROC. Membership in the AFROC consists of O-7/O-8 representatives from HQ AFMC, HQ AFOTEC, AF/PE, AF/TE, AF/LG, AF/IN, AF/XOM, SAF/AQ, SAF/FM, and the MAJCOM requirements principal whose requirement or need is under AFROC consideration. Normally HQ AFSPC/DR attends and the CL briefs the AFROC.

4.1.5.1.2. The briefing format for the AFROC is contained in the AFROC charter dated 5 Dec 94 and is essentially the same as the JROC format contained in the JROC Administrative Instruction (JROC 050-92, 6 Jul 92). These documents are maintained in HQ AFSPC/DRR.

4.1.5.1.3. After a successful AFROC, the MNS is ready for AFSPC/CC nomination for CSAF approval.

4.1.6. After HQ AFSPC/CC signature on the MNS transmittal letter, AFSPC action is complete, pending CSAF approval and a milestone decision by the appropriate acquisition executive.

4.1.7. Occasionally, a MNS out for comment or a validated MNS may need to be withdrawn. Such action requires RRC coordination and approval by the Commander. If such action is approved, the CL will send written notification to DRR for reflection in the semi-annual certification list submitted to HQ USAF/XOR.

4.2. How to Process ORD/RCMs:4.2.1. An ORD/RCM is required for all funded programs. ORD/RCMs are developed through the activities of the CAG, using the results of the COEA, the CONOPS, and other Phase 0 studies, e.g., IMPACTS comparability and Training System Requirements Analysis (TSRA).

4.2.2. Process ORD/RCMs basically the same as for MNS (see paragraph 4.1 and figure 2).

Following CAG preliminary actions, the document goes through division coordination until issues are resolved or ready to go to a higher authority for resolution.

4.2.3. The document then meets an Operational Requirements Review Board (ORRB). The intent of this review is to give DR and DDR an opportunity to review a program's detailed operational requirements and RCM prior to the program's RRP. Board membership should consist of as a minimum, DR, DDR, and the appropriate division chief.

4.2.4. The next step is RRP and RRC approval to release for MAJCOM and Air Staff review and comment (see figure 3). ORDs ready for USAF wide review and comment will be coordinated through DRR. The CL will provide the document in electronic form to DRR for EMail distribution. DRR will distribute the ORDs by EMail where possible and by mail (paper copy) where EMail is not possible. (EMail distribution can be made up to SECRET level.) When comment resolution is completed, another RRC or directorate coordination via staff summary sheet is accomplished and then the document is sent to HQ USAF/XORD for their final two letter coordination.

4.2.4.1. While at Air Staff the ORD/RCM will go through an AFROC. Normally HQ AFSPC/DR attends and the CL briefs the AFROC. The AFROC specifically checks to see that emerging performance objectives and thresholds adequately address the mission need. They also ensure quality articulation of the operational requirements in the ORD/RCM and validates the linkage to the MNS and COEA. The AFROC verifies thresholds, key performance parameters, and supporting justification.

4.2.5. After Air Staff coordination the document comes back to AFSPC for Commander signature on a nomination letter to HQ USAF/XO. This letter states that the requirements represent a MAJCOM position and requests approval at the appropriate level. 4.2.6. CL responsibility for staff actions on the ORD/RCM include: scheduling RRP/RRC pre-briefs and briefings to the RRP and RRC, reproduction, distribution, mailing, external review, comment resolution and AFROC/JROC briefings. All activities must be coordinated through HQ AFSPC/DRR.

4.3. How to Process COEAs and CBAs:

4.3.1. COEAs and CBAs are processed the same as MNSs and ORD/RCMs with the exception that the controlling organization is HQ USAF/XOM versus XOR. Before performing the analysis, the CAG will submit a COEA Resource Oversight Proposal to HQ USAF/XOM at the same time the MNS is submitted for approval. A study director (normally the CL) is appointed to oversee accomplishment of the COEA and report. When the COEA is approved, the final document will recommend the best cost and operationally effective alternative for the required system.

4.4. How to Process External MNS/ORD or N-MNS:

4.4.1. HQ AFSPC/DRR is the Command focal point for all N-MNSs and external MNS/ORDs and will assess these documents for AFSPC interest.

4.4.2. If these documents lack Command interest, HQ AFSPC/DRR will announce the document's existence to the RRP members and invite their review and comment of the file copy. HQ AFSPC/DRR will consolidate comments provided and respond to the originator prior to the suspended date.

4.4.3. For documents in which AFSPC takes an interest, HQ AFSPC/DRR will determine what mission area the requirement addresses and coordinate with the appropriate DR division to identify an action officer and establish a suspense. The action officer will be responsible for distribution of the document, solicitation of comment, comment consolidation, and preparation of the Command response. HQ AFSPC/DRR will review and sign out the Command response.

4.5. How to Process APBs and PMDs:

4.5.1. HQ AFSPC/DRR is the Command focal point for all APBs and PMDs.

4.5.2. Upon receipt, HQ AFSPC/DRR enters the document in the Command requirements database and sends it to the appropriate DR division for staffing. The assigned division will designate a POC that will be responsible for review and comment. The designated POC collects all comments and provides the proposed AFSPC response for directorate coordination. If necessary, a staff summary sheet is prepared requesting HQ AFSPC/DR signature on the attached AFSPC response to the originator.

4.5.3. Suspenses on APBs and PMDs are 5 working days and 10 working days, respectively, within the Command. Because of the very short suspense, APBs enter the review cycle at the directorate level. PMDs are coordinated at the three-letter level. Following coordination, the APBs and PMDs will be sent to the Command section for approval of a HQ AFSPC/DR response.

OPERATIONAL REQUIREMENTS STAFFING PROCESS (DRAFT MINS, ORD, COEA, et. al.)

PARTICIPANTS

DR (IMA) CEP DRC DRF DRM DRR
 DRS DOX FMA INX LGX SEC SCX
 SPX SWC/XR XPX 14AF/DO 20AF/DO

DR (IMA) CEP DRC DRF DRM DRR
 DRS DOX FMA INX LGX SEC SCX
 SPX SWC/XR XPX 14AF/DO 20AF/DO

CE DO FM IN LG SC
 XP DR USJ5 N/J5

DOCUMENTATION

Memorandum
 3 Letter Coord
 Transmits Draft
 2 Week Suspense
 1st Indorsement
 () Comments Attach
 () No Comment
 () Not Applicable

Draft

RRC Members
 SSS
 1 Week Suspense
 Sets Meeting
 Transmits Draft
 with Comment
 Resolution
 Recommendation Draft
 to RRC for Action

Draft

RRC Members
 SSS
 2 Week Suspense
 Sets Meeting
 Transmits Draft
 Includes Comment
 Resolution and
 RRP Coordination
 Recommendation Release
 for AF-Wide R&C

Draft

ACTIONS

Comment Resolution
 and New Draft
 As Required

RRP
 Pre-Brief
 to DRR

Comment Resolution
 and New Draft
 If Required

RRC
 Pre-Briefs
 to DRR
 and DR

AFSPC RRP Coord
 Approve DR Release
 for AF-Wide Review

Categorize Comments:
 Critical/Substantive/Admim
 Coordinate Resolution with
 Commentor

RRP Members Sign SSS

See Approval Process

AF
 R&C

FIGURE 2

OPERATIONAL REQUIREMENTS APPROVAL PROCESS

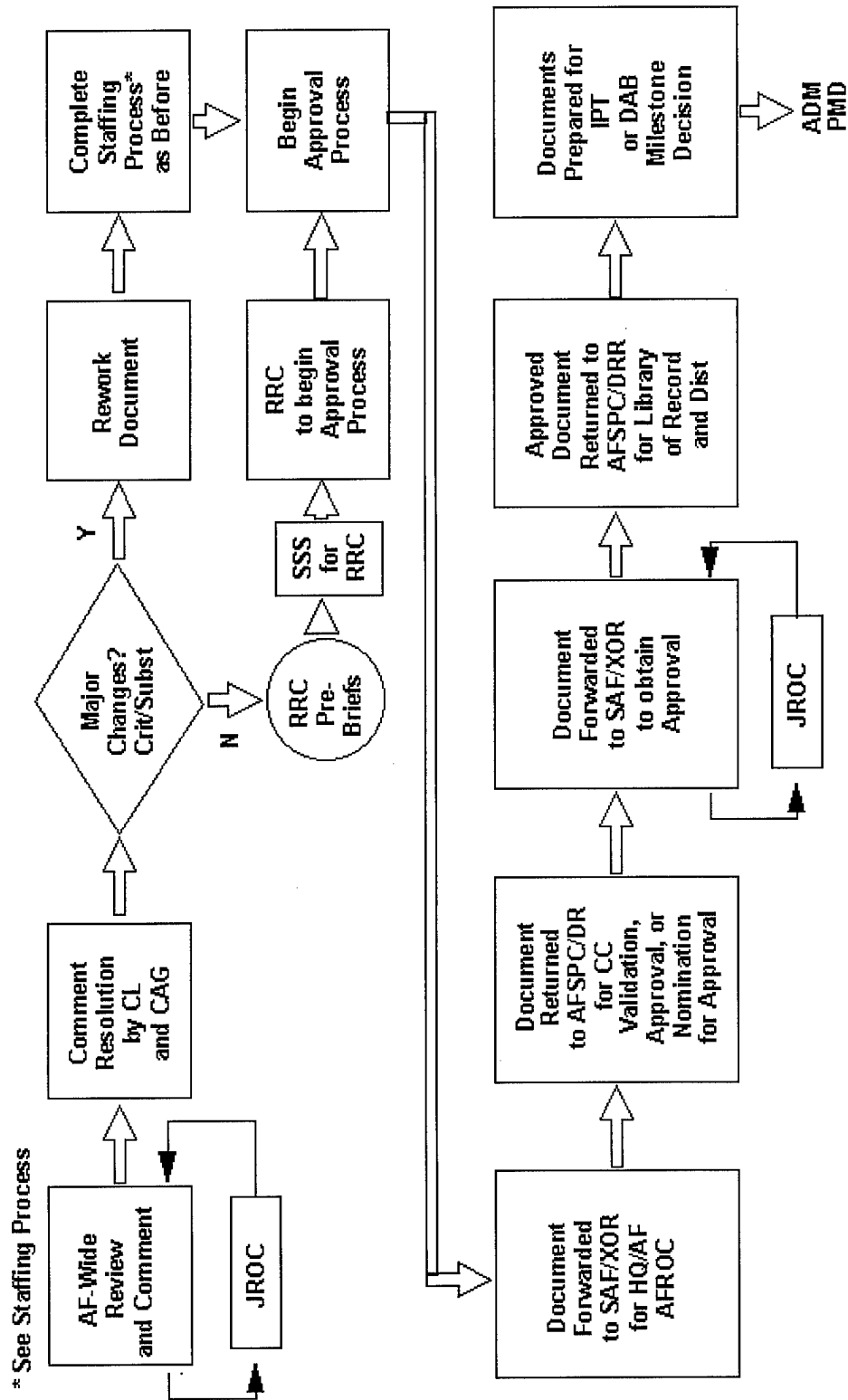

FIGURE 3

5. **Command Lead Authority and CAG Development.** This section describes the procedures for the Command Lead to form a CAG and execute the responsibilities assigned to AFSPC.

5.1. The CL has the authority to task members of the CAG to accomplish the responsibilities assigned to AFSPC in Phase 0 of the requirements and acquisition processes. The CL will ensure the operational user community, implementing command(s), and the AFSPC staff elements are adequately represented.

5.2. The CL will establish a schedule and ensure the CAG receives Quality AF Team Training. An objective of team training is to develop a charter for the CAG. The CAG Charter is a contract between HQ AFSPC/DR and the CAG.

5.2.1. Section one of the CAG charter, the situation statement, explains the reason the CAG was formed, by what authority, what the CAG is expected to accomplish, and how the CAG will accomplish it.

5.2.2. Section two of the CAG charter is comprised of guidelines, operating instructions, and administrative procedures necessary for CAG operation. Section two establishes the CAG code of conduct and decision making processes. It authorizes and sets procedures for developing schedules, agendas and publishing minutes of meetings.

5.2.3. Section three of the CAG charter contains the CAG composition. The CL determines CAG membership, and invites prospective participants by letter. See paragraph 3.3.

5.2.4. Once the CAG has written the charter and agreed to it, send the charter to the process owner (in most cases this will be the DR) for signature.

5.3. Additionally, the CL will evaluate the need for "Just-in-Time Training" throughout the CAG activities. This is in-depth, "how to" training on specific tasks such as developing a Request For Proposal (RFP), a COEA, or an ORD/RCM. It may also cover document reviews or analyses. Just-in-Time Training is available from many sources and HQ AFSPC/DRR can assist a CL in obtaining training.

6. Concept Studies, COEA and ORD/RCM Development:

6.1. At MS-0, the MDA will issue an Acquisition Decision Memorandum (ADM). An ADM documents program decisions made, and the exit criteria established, as a result of a milestone decision review.

6.2. The draft PMD issued by AF/XOR should direct the feasible concepts to be examined in the concept studies. These feasibility concepts should be the ones provided by AFSPC in a draft PMD provided pre MS-0. The draft PMD should also direct accomplishment of a COEA if required. The CAG will review and coordinate on the draft PMD when provided by HQ USAF/XOR. It is particularly important to understand the schedule contained in the PMD. The task of developing a Statement of Work (SOW) or RFP is time consuming. Time for advertising and award of a contract for concept studies must be considered. Typically, concept studies could extend from six months to over eighteen months. Additionally, within 30 days of CSAF approval of the MNS, the CAG must submit our AFSPC COEA Resource/Oversight Proposal (CROP) for potential ACAT I programs. A CROP submittal is also required for other than ACAT I programs if SAF/AQX or HQ USAF/XOM determine a COEA is necessary.

6.3. At the conclusion of concept studies the CAG should have a short list of most feasible and acceptable alternatives to be included in a COEA. During Concept Studies, the CAG determines a COEA Oversight Group (COG) review date in coordination with USAF/XOME and prepares a COEA study plan (if required). The COEA Study Plan must follow the guidelines in IMC to AFI 10-601 and provide the detailed method by which the COEA will be developed. As a minimum it will include the alternatives to be considered, resources required, and milestones. The draft COEA study plan will be forwarded to USAF/XOME approximately six weeks prior to the pre-arranged COG assessment date. After AFSPC/CC validates and the COG approves the study plan, XOM will release funds (if available) for the COEA effort. The COEA supports decision makers in

selecting the most cost-effective materiel alternative to satisfy a mission need. It compares alternative solutions on the basis of cost and operational effectiveness, documents the analytical rationale for choosing the preferred alternative, and justifies the need for starting or continuing an acquisition program. The COEA establishes the Measures of Effectiveness (MOE), explores the issues and alternatives, and determines the preferred alternative. The implementing command, HQ AFMC, and HQ Air Force Operational Test and Evaluation Center (AFOTEC) will assist in developing the MOEs.

6.3.1. The MS-I COEA (COEA I) will be based on the MNS and the CONOPS and will support the lead MAJCOM/CC's selection of the preferred alternative during acquisition Phase 0, Concept Exploration and Definition. It analyzes a broad range of alternative concepts to satisfy a mission need, e.g., manned aircraft, unmanned air vehicle, or space surveillance system.

6.3.2. The MS-II COEA (COEA II) analyzes and evaluates a range of specific hardware alternatives. In contrast to COEA I, it will be sufficiently detailed to help determine both a preferred hardware alternative and its military worth. For example, if COEA I determined that a manned bomber is the preferred alternative, COEA II would focus on a specific set of manned aircraft alternatives e.g., single-seat/single engine vs. dual-seat/twin engine.

6.3.3. COEA III (if required) analyzes factors that have changed since MS-II, based on engineering and testing.

6.4. Each alternative will include a narrative evaluation of operational effectiveness with measures of effectiveness, measures of performance, and costs for each system. The CAG will review the summaries and select the preferred alternative for review by the RRP/RRC and approval or nomination by AFSPC to the appropriate MDA for approval. This preferred alternative will be reflected in the final COEA document.

6.5. During Phase 0, a number of parallel activities are ongoing in several functional areas including training, testing, logistics, environmental, MILCON or other facility requirements, development of contract documentation, BPPBS, and many others. The CL must remain fully aware of all activities and the effects each has on the others. The CAG is the forum to bring all this information together with an awareness of each functional area. Disconnects and issues can be resolved in an open cooperative forum. Issues that are difficult to resolve can be investigated and brought to the highest level in a coordinated and cogent manner. It is imperative a CAG be formed and trained, and a charter be developed to set the standards for conducting business, making decisions, and documenting all activities.

6.6. The CL is responsible, as the AFSPC single point of contact for a program, for all aspects for the Phase 0 activities. All briefings and documentation required for program reviews, Summits, and milestone decisions are the responsibility of the CL and CAG to deliver. One of the most important aspects of these responsibilities is realistic scheduling of events and activities. A thorough understanding of the process is required. Even more important is an understanding of the activities described above (concept studies, COEA, ORD/RCM) and how long each activity takes including the lengthy administrative process to review, validate, and approve the final documents.

6.7. The CL is responsible to keep his/her Division Chief informed of actions taken to satisfy customer concerns. The sample Customer Feedback Questionnaire (Attachment 1) is provided for each CL and CAG to use as a guide in developing a similar product to be used as a means of assessing how well AFSPC interacts with key users of a particular program. A sample Customer Satisfaction Feedback Assessment (Attachment 2) describes the flow of the customer satisfaction process from identification of a problem through the recommended fix to ultimately improve relationships. The CL should also keep a record of comments and comment resolution throughout the development of the required documentation. A sample Comment Resolution Format is provided at Attachment 4 for each CL to use as a guide.

6.8. The CL is responsible to his/her Director for periodic program reviews of progress throughout

Phase 0 as well as post MS-1 activities.

7. AFSPC Responsibilities in the Acquisition Process, Post MS-I. This section describes the responsibilities of the CL and the CAG in the acquisition process post MS-I.7.1. At MS-I, the MDA will issue an ADM. SAF/AQ will issue a PMD to direct Phase 1, Demonstration and Validation. MS-I is program initiation.

7.2. If not already established the implementing command will establish a SPO and appoint a System Program Director (SPD). The Integrated Weapon System Management (IWSM) concept dictates the SPD will remain the single face to the operator throughout the system life cycle.

7.3. The draft PMD will be provided to HQ AFSPC/DRR by SAF/AQ for review, comment and coordination. HQ AFSPC/DRR will receive all draft PMDs, suspense the action, and forward to the appropriate DR division for division review and coordination (see paragraph 4.5.). The CL will be responsible for resolving all comments to the draft PMD. A final response to the draft PMD will be prepared by the CL, coordinated through the respective Division Chief and provided to HQ AFSPC/DRR for suspense control, obtaining appropriate signature and forwarding to SAF/AQ office of origin.

7.4. The final PMD will be forwarded from SAF/AQ through HQ AFSPC/DRR to the CL. This document will contain program direction to include all AFSPC responsibilities and actions through the current phase. SAF policy is that all PMDs are to be updated every two years to reflect changes in program direction and budget decisions.7.5. Typical responsibilities assigned to AFSPC, delegated to the CL, carried out by the CAG and included in a PMD include, but are not limited to:7.5.1. The CL is the AFSPC single interface to the implementing command(s) and the user(s) throughout the acquisition life cycle.

7.5.2. The CL staffs and coordinates all issues within AFSPC concerning the program.7.5.3. The CL is the prime AFSPC advocate for the program.7.5.4. The CL is responsible for communicating all aspects of the program to the Command directly, or indirectly through the CAG or IPT, and preparing all communications outside the command, staffing and coordinating as required.

7.5.5. The CL will keep the CAG informed and direct CAG efforts in an effective and efficient manner to discharge AFSPC responsibilities.

7.5.6. The CL will participate in or be cognizant of all activities to translate operational requirements from the ORD/RCM into an RFP, SOW, or specifications. This requires CL and CAG participation in technical meetings and review of technical documents.

7.5.7. The CL is responsible to ensure all AFSPC requirements documentation supporting program reviews, summits, and milestone decisions are completed and coordinated by AFSPC.

7.5.8. The CL is responsible to ensure MILCON in support of system acquisitions is properly planned, programmed, and budgeted for.

7.5.9. The CL is responsible to ensure the tenets of the EIAP are adhered to and followed including an environmental assessment and environmental impact statement, as required. HQ AFSPC/CE will provide a CAG member to execute the EIAP (Ref para 2.7.4).

7.5.10. The CL is responsible for obtaining validation and approval of new or changed operational requirements as the program matures through the life cycle.

7.5.11. The CL is responsible for identification of the need for modifications, upgrades, and follow-on programs, as are other participants in the process.

7.5.12. The CL is responsible for conducting and completing the AFMC customer satisfaction survey, when requested.

7.5.13. The CL is responsible for establishing, conducting and analyzing a customer survey with other users to establish the effectiveness of the AFSPC process to gather and validate user requirements.

7.5.14. The CL is responsible for keeping all CAG members informed of program progress including technical reviews, etc. The CL will schedule and conduct periodic reviews for HQ AFSPC/DR.

7.5.15. The CL must confirm the requiring/implementing command has the appropriate Delegation Procurement Authority (DPA) to accomplish the resulting acquisition of Federal Information Processing Systems (FIPS) resources as appropriate.

7.6. AFSPC responsibilities for ORD/RCM and COEA, including respective CONOPS, review and revision remain through the life cycle. The responsibility for program execution within budget, performance and schedule transfers to the SPD at MS-I. The IWSM process begins at MS-I and the CL supports IWSM through the CAG.

7.7. HQ AFSPC responsibilities for program advocacy through the POM and the BPPBS are assigned to the CL and coordinated through the CAG.

7.8. The CL will work with the PEM to ensure all planning, programming, and budgeting issues are addressed for the entire program.

7.9. When the system becomes operational, at a predetermined time or event, HQ AFSPC/DR will relieve the CL, in writing, of responsibility and transfer responsibility to an appropriate AFSPC Directorate, normally AFSPC/DO, for sustainment and operations advocacy and management.

H. MARSHAL WARD, Brigadier General, USAF
Director of Requirements

Attachments

1. AFSPC Customer Feedback Questionnaire
2. Customer Satisfaction Feedback Assessment
3. Acronym List
4. Comment Resolution Format

**AIR FORCE SPACE COMMAND
CUSTOMER FEEDBACK QUESTIONNAIRE**

5
Satisfied
3
Somewhat
Dissatisfied
4
Somewhat
Satisfied
6
Very
Satisfied
1
Very
Dissatisfied
2
Dissatisfied

INSTRUCTIONS: Please use the following scale to answer the following questions. Your honest feedback will help us determine how well we are meeting your Space Requirements.

1. Is your organization treated as a member of the team?

2. Have you been provided an opportunity to participate in all plans development?

3. Did your organization:

- a. review all Requirements Documents (RD)?
- b. comments get incorporated into the RD?

c. agree on the final RD?

4. Was adequate time provided to review the RD?

5. Were you involved in comment resolution of the RD?

6. Was your organization a part of program scheduling?

7. Were you provided information that was:

- a. Useful?
- b. Timely?

c. Consistent?

8. Have your Space Requirements been adequately met?

Please use the back side of this form to expand upon any ratings of 1, 2, or 3, or to provide additional information. Thank you for taking the time to complete this questionnaire.

CUSTOMER SATISFACTION FEEDBACK ASSESSMENT

DATE:

PROGRAM:

COMMAND LEAD:

CUSTOMER:

PROBLEM

CUSTOMER COMMENTS:

BACKGROUND:

PROPOSED ACTION:

STATUS:

DATE BRIEFED BRANCH CHIEF:

ACRONYM LIST

ACAT Acquisition Category
ADM Acquisition Decision Memorandum
AFI Air Force Instruction
AFMC Air Force Materiel Command
AFOTEC Air Force Operational Test and Evaluation Center
AFPD Air Force Policy Directive
AFROC Air Force Requirements Oversight Council
AFSPC Air Force Space Command
APB Acquisition Program Baseline
BPPBS Biennial Planning Programming Budgeting System
C4 Command, Control, Communications & Computers
CAG Concept Action Group
CBA Cost Benefit Analysis
CINC Commander in Chief
CJCS Chairman of the Joint Chiefs of Staff
CL Command Lead
CMS Command Management Seminar
CMG Command Managers Guide
COEA Cost Operational Effectiveness Analysis (see ICM to AFI 10-601 for more information)
COG COEA Oversight Group (see ICM for AFI 10-601 for more information)
CONOPS Concept of Operations
CRLCMP Computer Resources Life Cycle Management Plan
CROP COEA Resources/Oversight Proposal
CRWG Computer Resources Working Group
CSAF Chief of Staff, Air Force
CSRD Communications Computer Systems Requirement Document
DAB Defense Acquisition Board
DAE Defense Acquisition Executive
DDL Delegation of Disclosure Authority Letter
DoD Department of Defense
DoDI Department of Defense Instruction
DPA Delegation Procurement Authority
DPG Defense Planning Guidance
EIAP Environmental Impact Analysis Program
ESC Electronic Security Center
FIPS Federal Information Processing Systems
HOI Headquarters Operating Instruction
IAW In Accordance With
ICBM Intercontinental Ballistic Missile
ICO Intelligence Counterpart Officer
ILSP Integrated Logistics Support Program
IMPACTS Integrated Manpower Personnel and Comprehensive Training and Safety
IOC Initial Operating Capability
IPT Integrated Product Team
ISP Intelligence Support Plan
ISWG Intelligence Support Working Group
ITW/AA Integrated Tactical Warning and Attack Assessment
IWSM Integrated Weapon Systems Management
JROC Joint Requirements Review Council
LSA Logistics Support Analysis
MAA Mission Area Assessment
MAJCOM Major Command
MAP Mission Area Plan
MDA Milestone Decision Authority
MER Manpower Estimate Report
MILCON Military Construction

MNA Mission Need Analysis
MNS Mission Need Statement
MOE Measure of Effectiveness (see DoDI 5000.2 and ICM to AFI 10-601 for more information)
MP Master Plan
MS-I Milestone I
MS-II Milestone II
MS-0 Milestone 0
N-MNS NORAD Mission Need Statement
NMS National Military Strategy
NORAD North American Aerospace Defense Command
NSS National Security Strategy
OPR Office of Primary Responsibility
ORD Operational Requirements Document
ORRB Operational Requirements Review Board
O&S Operations and Support
OSD Office, Secretary of Defense
P3 Pollution Prevention Program
PEM Program Element Monitor
PMD Program Management Directive
POC Point of Contact
POM Program Objective Memorandum
RCM Requirements Correlation Matrix
RDT&E Research Development Test & Evaluation
RFP Request For Proposal
RRC Requirements Review Council
RRP Requirements Review Panel
SAE Service Acquisition Executive
SOW Statement of Work
SPD System Program Director
SPO System Program Office
SSS Staff Summary Sheet
STA System Threat Assessment
STAR System Threat Assessment Report
STT Strategy-to-Task (see AFI 10-601 for more information)
TEMP Test and Evaluation Master Plan
TSRA Training System Requirements Analysis
TTN Task-to-Need (see AFI 10-601 for more information)
TPIPT Technology Planning Integrated Product Team
TQM Total Quality Management
USD(A&T) Under Secretary Of Defense, Acquisition and Technology
USSPACECOM United States Space Command
USSTRATCOM United States Strategic Command
VCSAF Vice Chief of Staff of the Air Force
WSMP Weapon System Management Program

Comment Resolution Format

DOT	Page 5-3, para 5.3.1, 4th sentence. SUBSTANTIVE: Is the NORAD and USSPACECOM data that is entered into the information system simultaneously available for numerous warfighting CINCs?	ACCEPTED. Sentence is written to state that fact.
SCX	Page A-3, Table A-3. ADMINISTRATIVE: The table continues for three pages with no explanation of what the symbols (e.g. * and ^) mean until the final page (A-6). Recommend adding an explanation as a footnote on each page of the table. Rationale: Reduce confusion and clarify meaning of the symbols.	ACCEPTED. Appendix A has been modified.
NAVSP/N515	Page A-3, Table A-3. SUBSTANTIVE: It is recommended that C be added as an additional programming language in the current and near term environments.	PARTIALLY ACCEPTED. Table had been revised to only include the TAFIM rather than specific standards.
N/J5R	Appendix A. CRITICAL: Appendix A contains too much detail for an "Overview" volume. Suggest putting Appendix A in a more detailed section.	ACCEPTED. Appendix 3 has been rewritten based on revisions to Section 3.
SCX	Appendix E. ADMINISTRATIVE: Delete N/J5X from distribution list.	REJECTED. NORAD is the user of the system and N/J5X maintains copies of all their ORDs.

Critical - Critical comments will cause nonconcurrency with the document if comment is not satisfactorily resolved.

Substantive - Substantive comments are provided because sections in the document appear to be or are potentially unnecessary, incorrect, incomplete, misleading, confusing, or inconsistent with other sections.

Administrative - Administrative comments correct what appears to be typographical or grammatical errors.