

JPRS-UMA-92-026

15 JULY 1992



**FOREIGN
BROADCAST
INFORMATION
SERVICE**

JPRS Report

DISSEMINATION STATEMENT A

Approved for public release
Distribution Unlimited

Central Eurasia

Military Affairs

DTIC QUALITY INSPECTED 2

19980116 058

Central Eurasia

Military Affairs

JPRS-UMA-92-026

CONTENTS

15 July 1992

CIS/RUSSIAN MILITARY ISSUES

CIS/RUSSIA ARMED FORCES

Homeless Servicemen Protest in Moscow [KRASNAYA ZVEZDA 4 Jul]	1
Impending Disbanding of Helicopter Regiment [KRASNAYA ZVEZDA 9 Jul]	1

CIS: GROUND TROOPS

Problems in Subunit Fire Control Still Remain [VOYENNY VESTNIK No 5, May 91]	2
On Military Stratagem [VOYENNY VESTNIK No 6, Jun 91]	4
Reconnaissance Ambush Parties [VOYENNY VESTNIK No 6, Jun 91]	8
Support to Airborne Assault Landing [VOYENNY VESTNIK No 8, Aug 91]	11
In Maneuver Defense [VOYENNY VESTNIK No 8, Aug 91]	14
Design Features of BAZ-6953 Artillery Tractor [TEKHNIKA I VOORUZHENIYE No 3-4]	16

CIS: AIR, AIR DEFENSE FORCES

Uncertain Future Facing Aviation Division in Byelarus [KRASNAYA ZVEZDA 4 Jul]	17
---	----

CIS: NAVAL FORCES

Profile of Surface Effect Ship 'Zubr' [KRASNAYA ZVEZDA 18 Jun]	19
--	----

CIS: REAR SERVICES, SUPPORT ISSUES

Central Finance Directorate Chief Interviewed [KRASNAYA ZVEZDA 30 Jun]	20
Technical Problems With Disposal of Nuclear Warheads [NEZAVISIMAYA GAZETA 17 Jun]	22
Siberian MD Chief on Improving Social Protection [KRASNAYA ZVEZDA 7 Jul]	25
Problems of Reforming Russian Military Schools Examined [KRASNAYA ZVEZDA 8 Jul]	26
Aide on Plans for Army Participation in Harvest [KRASNAYA ZVEZDA 9 Jul]	28

STATE AND LOCAL MILITARY FORCES

INTERREGIONAL MILITARY ISSUES

Russian Munitions Seized by Kaitseliit [ROSSIYSKAYA GAZETA 27 Jun]	30
Impact on Servicemen of Estonian Currency Exchange [KRASNAYA ZVEZDA 2 Jul]	30
New 14th Army Commander Accuses Moldova of Massing for Attack [KOMSOMOLSKAYA PRAVDA 7 Jul]	31

UKRAINE

Kiev Officers' Union Protests Morozov Statements on Those Not Taking Oath [LITERATURNAYA UKRAYINA 18 Jun]	32
Cabinet Resolution Improving Servicemen's Allowances [NARODNAYA ARMIYA 23 Jun]	33
Ukrainian Language Military Laws Provided To Sailors [NARODNAYA ARMIYA 24 Jun]	33

BALTIC STATES

Statistics on Russian Troops Stationed in Lithuania [LITHUANIAN WEEKLY 12-18 Jun]	34
---	----

CAUCASIAN STATES

Creation Of Azerbaijani National Army Discussed [EDEBIYYAT GEZETI 1 May] 34

CENTRAL ASIAN STATES

Process of Forming Kazakh Armed Forces [KRASNAYA ZVEZDA 2 Jul] 36

Uzbek Defense Ministry Takes Over Newspaper 'Frunzevets' [KRASNAYA ZVEZDA 7 Jul] 38

Language Training for Uzbek Army Commanders Started [KRASNAYA ZVEZDA 9 Jul] 39

MOLDOVA

Reports, Interviews From Visit to 14th Army [KRASNAYA ZVEZDA 26 Jun] 39

Profile of Dniester Region Commandant Bergman [KRASNAYA ZVEZDA 7 Jul] 41

GENERAL ISSUES

DEFENSE INDUSTRY

Kuybyshev Military-Engineer Academy Offers Boring Equipment
[TEKHNIKA I VOORUZHENIYE No 3-4] 44

Scientific-Engineering Center Offers Consulting Services
[TEKHNIKA I VOORUZHENIYE No 3-4] 44

NPO 'Uran' Offers Underwater Towed Sensor for Sale
[TEKHNIKA I VOORUZHENIYE No 3-4] 44

Russian Cocom to be Established [KOMMERSANT No 24, 8-15 Jun] 45

Ryazan Defense Industry Workers Threaten "Civil Disobedience"
[SOVETSKAYA ROSSIYA 2 Jul] 45

DOCTRINAL ISSUES

Conference on Russia's Military Policy [KRASNAYA ZVEZDA 4 Jul] 46

MILITARY CONFLICT, FOREIGN MILITARY AFFAIRS

Development of Troop Command and Control [VOYENNY VESTNIK No 6, Jun 91] 46

U.S. Ballistic Missile Control Systems [TEKHNIKA I VOORUZHENIYE No 3-4] 49

Commentary on Suggestion for Permanent UN Armed Forces [KRASNAYA ZVEZDA 4 Jul] 53

SECURITY SERVICES

Ukrainian Border Guards: Rising Illegal Immigration From Asia
[NARODNAYA ARMIYA 24 Jun] 54

CIS/RUSSIA ARMED FORCES

Homeless Servicemen Protest in Moscow

92UM1210A Moscow KRASNAYA ZVEZDA in Russian
4 Jul 92 First edition p 1

[Report by Captain 3rd Rank Yu. Gladkevich: "The Servicemen Without Housing Are Not Asking for Anything: They Are Demanding"]

[Text] Demeaned by many years of being ignored by the fatherland, Russian officers, seagoing and shore-based warrant officers, who have served and continue to serve the fatherland honorably, do not intend to lower themselves to plead with the nation's leaders for the right to live like human beings. This, briefly, is how one could describe the mood of participants in a meeting of Moscow servicemen without housing held last Thursday in the Officers' Club of the Moscow Military District.

The Joint Committee of Moscow Servicemen invited the president of Russia, the chairman of the Supreme Soviet of the Russian Federation, the acting chairman of the government of Russia and officials of the Moscow soviet and the government of Moscow to participate in the meeting. None of the higher officials attended the meeting, however. Representatives from the office of Russian Federation Vice President A. Rutskoy, the government of Moscow and the capital's municipal housing department did in fact participate in the meeting, but they were unable to provide answers to the main questions on the agenda—and could not have done so due to their positions within these structures.

An army ceases to be an army when its backbone, the regular military personnel, are forced to put all their efforts into providing some kind of living conditions for their families. This was the spirit of what many participants had to say. A resolution approved at the meeting outlined some very rigid demands of the nation's leaders, including the demand that a state commercial program to provide servicemen with housing be worked out and published as rapidly as possible. It was decided to send the resolution to the president of Russia. If the demands of the servicemen without housing are not heeded, it is planned to hold a meeting to defend the servicemen's right to housing in September.

Impending Disbanding of Helicopter Regiment

92UM1234A Moscow KRASNAYA ZVEZDA in Russian
9 Jul 92 First edition p 2

[Article by KRASNAYA ZVEZDA correspondent Major S. Knyazkov: "The Last Flight Is Coming: How the Biography of the Tskhinval Helicopter Regiment Is Being Completed"]

[Text] The Separate Red-Banner Helicopter Regiment of the Transcaucasus Military District based in Tskhinval celebrated only its 15th anniversary on 13 May 1992, but already beginning in January the most contradictory

rumors had been making the rounds about the fate of the regiment: it would be pulled out or would not be pulled out of Tskhinval; the regiment was staying but, as in Afghanistan, each person would serve only two years in it; and finally, disbandment... Just try to think how to arrange your career. Add to this the missile-artillery and automatic weapon firings on the city, which did not let up day or night and in which the military pilots also often were on the receiving end...

Georgian National Guardsmen kept the grounds of the regimental headquarters, enlisted men's barracks and flight-technical personnel training buildings in their sights. The windows already were without glass and the walls preserved traces of bullet and rocket hits. I saw the stabilizing fins of a grenade fired against the barracks from the Georgian side from a shoulder-fired antitank grenade launcher on the desk of regimental commander Colonel Aleksey Vostrikov.

That is the life they live. It is no accident that the helicopter regiment's headquarters today represents a small fortified position. Sandbags at the traffic regulating point, duty officers with assault rifles (no more than 15 enlisted men remained in the regiment), and a small concrete pillbox next to the gate... True, airborne personnel had arrived here recently as reinforcements, and now the aviators felt more or less safe.

But the airfield, motor pool and regimental housing area could come under fire in addition to the headquarters. It was 6 km from the housing area to the airfield, and this route had to be driven through streets that could be covered by fire.

The hill before the headquarters entrance was especially dangerous. Vehicles moved with difficulty here, which meant they presented a tempting target both for Georgian and Ossetian boyeviks. A tragedy almost occurred on this hill literally just before my arrival in Tskhinval. A bus with women heading for work was fired on. This time, fortunately, they got by without victims or wounds... But Captain A. Kudin was unlucky. He was driving through the city in his personal vehicle. Unfortunately he was spotted by Ossetian fighters along the way and they literally riddled the vehicle from 15 meters despite the fact that the officer was in military uniform. Kudin himself was wounded in the hand...

And so it goes for the third year already. Gunfire and attempts on the regiment's weapons and equipment have become especially more frequent since the decision was made for the regiment's withdrawal from Tskhinval.

Major Yuriy Puchkov, deputy regimental commander for work with personnel, told me: "The Georgian National Guard tried to seize the regimental airfield on the eve of the third vehicle column's departure from Tskhinval to take out personal articles of servicemen and their families. In response the Ossetians declared that families of regimental officers and warrant officers would be taken hostage if the airfield was seized. Well, the South Ossetian Supreme Soviet then adopted a

resolution nationalizing the unit. True, this was immediately followed by a statement from Colonel Vostrikov that the regiment would respond with fire to any encroachments.

Later there was a meeting with Vostrikov himself.

Tskhinval is the Colonel's seventh duty station. He arrived here from the Transbaykal, where he served seven years in Nerchinsk. He was squadron commander and regimental chief of staff for a year. He is commanding the unit in Tskhinval for the second year...

"I experienced all forms of training," admits Vostrikov. "Nine grades in the village in Altay Kray. I had to cope with 10th and 11th grades already in night school, and simultaneously worked at the Barnaul Transmash Plant. Then came the DOSAAF Novosibirsk Air Training Center. I was called into the Army in the rank of junior lieutenant. Here I completed aviation school as an external student, and ten years later I finished the Aviation Academy by correspondence."

Vostrikov is 41.

"If nothing out of the ordinary takes place, the regiment will not be here in two weeks," says Aleksey Nikitich, sighing heavily. "I am sorry for the regiment: I am already tired of knocking on doors at all levels and asking that it be kept in the Russian Army."

The commander can be understood. The unit really is unique. It was activated in 1977 based on an air detachment, and already three years later departed for Afghanistan at full strength. The regiment was awarded the Order of Red Banner on 11 March 1981. In Afghanistan 305 unit servicemen were recognized with awards, among them 19 with the Order of Red Banner, 152 with the Order of Red Star, and 69 with the Order "For Service to the Motherland in the USSR Armed Forces" 3rd Class; 45 were awarded the "Distinguished Service" medal, 13 the "Valor" medal, and 7 the "Excellence in Military Service" medal 1st Class.

After nine years of war in Afghanistan, the regiment took part in mopping up in the aftermath of the accident at the Chernobyl Atomic Electric Power Station and in events in Nagorno-Karabakh, Baku, Yerevan, Nakhichevan and, finally, South Ossetia.

The years spent in this senseless war remain in memory a long while. During my TDY alone several regimental helicopters which took off for a mission into Western Georgia received bullet holes. They got by without losses then, but how, how to explain the preposterous death of a boy-lieutenant on 15 June: for some reason he jumped out on the move after the helicopter landed on the airfield and... ended up under the helicopter wheel. Instantaneous death!

But perhaps it is all a matter of the unbelievably nervous and moral tension of the pilots, when even the elementary feeling of self-preservation and danger disappears? On 17 June a regimental Mi-8 crashed near Rokskiy Pass

over the territory of North Ossetia. The helicopter had delivered wounded from Tskhinval. In Vladikavkaz the pilots took aboard physicians and drugs and took off in the reverse direction... Captain Oleg Zaytsev, a very experienced pilot who had gone through Afghanistan and Ethiopia, and his subordinates, lieutenants Maksim Kolesnik and Georgiy Mitrofanov, perished with the passengers.

After the first ten regimental pilots died in Afghanistan, a helicopter was placed on a pedestal in Tskhinval in their memory on the grounds of the unit housing area. But where is the monument to pilots to be placed who died already after Afghanistan?

And the pilots themselves can no longer bear it. After my TDY I learned that on 28 June one of the pilots, Captain Vasilii Nekrylov, took off in a helicopter without appropriate permission to fly off to Russia. He obviously realized the absurdity of his act in the air. After circling the field, Nekrylov came in for a landing. The helicopter's rotor blades somehow touched the ground at the last moment and... caught fire. The pilot ended up in the hospital. A criminal case has been brought against him.

The regiment is leaving... Insulted by its fate, having lost its comrades in arms on the soil of South Ossetia. Personal articles have been sent off to relatives. Many officers and warrant officers have assignment orders in their hands about where to go to continue service. Probably everything is already clear for Lieutenant Valeriy Garpinok and his wife Nadezhda: relatives are in Kharkov... The family of Officer Valeriy Kuznetsov, wife Nina and three-year-old Kiryusha, also is ready to travel to Ukraine. But there are officer families who have nowhere to go—no relatives—and what looms before them is to begin everything in their lives from scratch. And what is in these people's hearts is probably understandable...

After rebasing to Krasnodar, the regiment is to be disbanded. Soon the regiment will be gone. Alas, not just people are perishing today, but military units as well.

CIS: GROUND TROOPS

Problems in Subunit Fire Control Still Remain

914C1784A Moscow VOYENNY VESTNIK
in Russian No 5, May 91 pp 47-48

[Article by Candidate of Military Sciences, Colonel V. Lykov: "Problems Still Remain"]

[Text] The issues concerning fire control always have been a topic of discussion in the Armed Forces. The inadequate skills of some subunit commanders in this sphere have been noted in the appropriate documents and the need to correct the situation has been stressed. But no particular improvement has been sensed thus far.

It is true that recently weapons designers have noticeably increased the capabilities of combat vehicles. A number

of organizational measures have also been adopted. For example, each firing training exercise in subunits is ending with a rehearsal of training issues on fire control. However, on the whole the problem remains unresolved. And as before, say, after the combat firing stage, the umpires are counting up to 10 shell holes in some targets and none at all in others, even those that are right alongside the ones with holes in them.

Even during the Great Patriotic War it became obvious that the fire superiority over the enemy obtained due to precise command and control and the subsequent decisive attack are the guarantee of victory and this has been repeatedly confirmed in battle.

Fire power has been increased in the postwar period, the armor protection of combat vehicles has been improved, and their mobility and operational reliability has increased. At the same time, research has been conducted to improve fire control systems. Optical and later laser range finders have been developed to increase the accuracy of determining target coordinates. More reliable radio transmitters have been developed to transmit commands and signals.

Nevertheless, on the whole views on fire control have not changed. The primary recommendations thus far as before have been based on the lessons of the past war. While analyzing the experience of troop combat exercises, we can conclude that subunit fire control has been transformed into a problem issue which it is hardly possible to resolve using traditional methods. In fact, existing surveillance and sighting devices do not support effective target search and detection. Too many subscribers operate on the battalion commander's radio net. Platoon commanders access to the airwaves to assign fire missions to subordinates is threatened by the disruption of command and control throughout the battalion. It is also impossible to disregard enemy employment of electronic countermeasures. All of this attests to the fact that current fire control methods obviously lag behind the requirements of modern combined arms combat.

In this situation, the question is being increasingly raised on automating the primary processes of troop and fire command and control. Research indicates that, with the automation of target designation, for example, the attackers' probability of victory increases by 30-40 percent. So, a system has demonstrated good results in laboratories where control was exercised by an automatic tank weapons guidance system based on a laser beam reflected from an enemy target transmitted from the company fire control control panel (Fig. 1).

However, this has turned out to be clearly inadequate. Target search and detection issues, weapons type and ammunition selection, adjustment of fire and monitoring the expenditure of ammunition also await their solution. Moreover, dust and smoke conditions on the battlefield can in a number of cases become a unique obstacle for a laser beam. Fire control is also complicated

Figure 1.

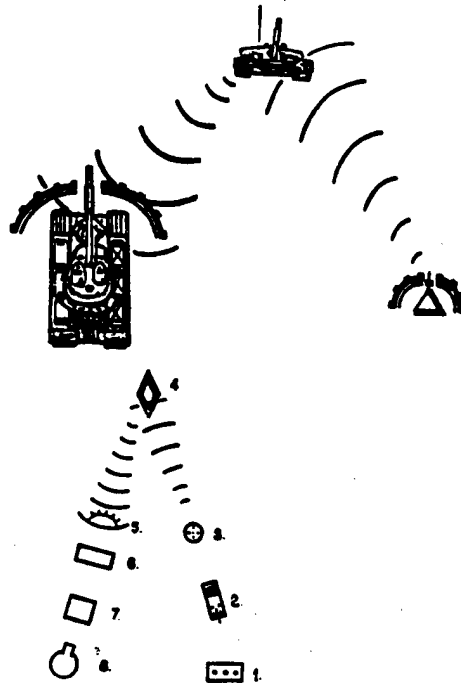

when there is no direct visibility between the control panel, the target and the combat vehicle.

Another direction of theoretical research is target designation using a ground navigation device (Fig. 2.). Single coordinate and direction in space systems are being installed for all crews. With the initiation of target designation, constant tracking occurs of changes in target position with regard to the selected calculation system. During the course of fire control, target coordinates are determined relative to the tank from which the command is issued. Target coordinates are calculated in the vehicles which receive the command. However, there are also problems here. And they are: large expenditures of time and significant errors during target orientation and the increase of errors in time. Furthermore, the issue of transmitting the fire control commands themselves has still not been totally resolved.

However, from our point of view, a third system (Fig. 3.), whose operating principle is approximately as follows, appears to be more promising. Initially, the relative positions of the command post and the firing tank are determined in two planes using a scanning laser beam. Then, information on target position arrives via an informational laser beam. This principle ensures high target designation accuracy for mobile and fixed targets that is not reduced in time.

But, unfortunately, for now we are compelled to only establish that further theoretical research and quite rare practical experiments of the matter of improving fire

Figure 2.

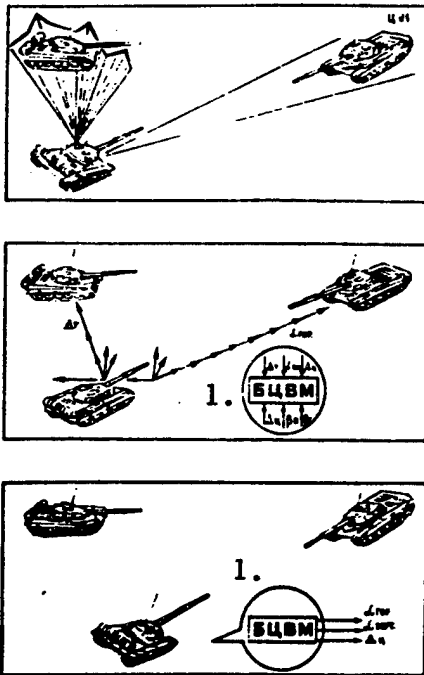

Key: 1. Onboard digital computer

control systems will not occur. In our view, it is long since time to conduct comprehensive complex research of the possibilities of automating all fire control elements. An optimal fire control effectiveness assessment methodology using automated systems is needed. Initially, research could be conducted in greater depth in a theoretical context and then practically as well. Indeed, this work has already begun and definite results have also been achieved, however, it is being conducted too slowly and it is obviously not finding proper support.

COPYRIGHT: "Voyenny vestnik", 1991.

On Military Stratagem

924C1787A Moscow VOYENNY VESTNIK
in Russian No 6, Jun 91 pp 48-53

[Article by Colonel V. Orlyanskiy: "On Military Stratagem"]

[Text] In all times, commanders have attempted to achieve victory with the smallest force and the "least blood" which required the high art of controlling sub-units in training and in battle. Perhaps the search for ways to achieve surprise, which largely promoted the successful completion of the combat mission, had the most important significance. Experience attests to the fact that skillful employment of a *military stratagem* yields the best results.

Even ancient military leaders, prior to battle, determined a so-called stratagem [stratagema] (or strategema) which expressed the mastery, resourcefulness and the art of deceiving the enemy. However, with time, due to the fact that a different meaning was imparted to the concept of "military stratagem", they began to use the corresponding term more rarely. A similar phrase is not encountered even in our modern encyclopedias or dictionaries.

In recent years, as a result of the development of military science, attempts have been made to more precisely formulate the essence of this concept, and to clarify the methods and techniques of military stratagem. Some authors present it as "the theory and practice of concealment and confusing the enemy".¹ In our opinion, this definition reveals the meaning of the term in one dimension by reducing it to primarily deceiving the enemy. Meanwhile, analysis of the primordial meanings of the words *cunning* [khitrost] and *deception* [obman], taken from various sources, permits us to discover not just their similarity but their substantial difference, too (See Table).

Figure 3.

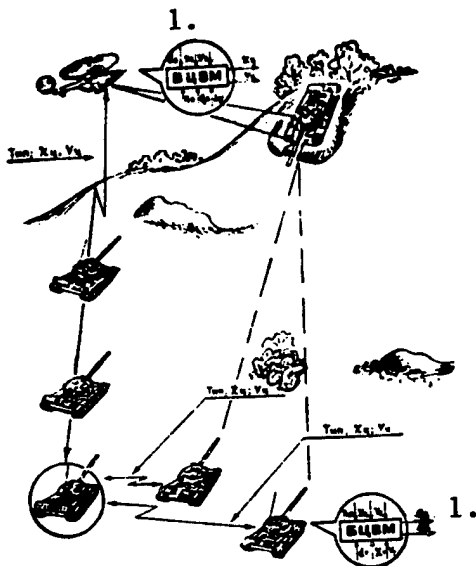

Key: 1. Onboard digital computer

Terms and Their Meanings

Khitryy	
skillful, intricate, ingenious, inventive ^{1,2} , clever ¹	
resourceful, moving along indirect, deceitful paths, ^{2,3}	
concealing your true intentions ³ .	
Khitrost	Obman
the attribute ³ (quality ¹) according to the meaning of the adjective "khitryy":	false notion of something, a delusion ⁴
craft, ability, art, trick ¹ , skill ^{1,3}	actions according to the meaning of the verb "obmanut" ³
intellectual dexterity, resourcefulness, subtlety and keenness of the ability to reason, ability to achieve one's goals, often through deception ¹ .	
Khitrit	Obmanut
to be clever, to think what is ingenious, cunning, skillful	to deliberately deceive someone, having stated an untruth or have resorted to some sort of guile ³
to be cunning, to deceive, to deliberately lead others to err ¹ .	

1. Dal, V.N., *Tolkovyy slovar zhivogo velikoruskogo yazyka* [Defining Dictionary of the Living Great Russian Language]—Vol 4, Moscow: Gozisdatsdat, 1935, pp 548-549.

2. *Tolkovyy slovar russkogo yazyka* [Defining Dictionary of the Russian Language]—Vol 4, Moscow: Gozisdatsdat, 1940, p 1147.

3. *Slovar russkogo yazyka* [Dictionary of the Russian Language]—Vol 2, Moscow: Rus. yaz., 1982, p 544, Vol 4, 1984, pp 599-600.

4. Ozhegov, S.I., *Slovar russkogo yazyka* [Dictionary of the Russian Language], Moscow: Rus. yaz., 1989, p 428.

It is obvious from this that the verbs *khitrit* [to be clever] and *obmanut* [to deceive] coincide in meaning in the sense of purposely (intentionally) leading someone into delusion (error). However, the word *khitrit* can also be used in the sense of to be subtle, to think ingeniously or skillfully which significantly expands the sphere of its use.

The meanings of the words *cunning* and *deception* also partially coincide. Thus, we understand the former to be first of all skill, art, and cleverness, and also the ability to attain an assigned goal. It can also be achieved through deception or by purposely leading someone astray. Hence it follows that deception is only a part of military stratagem.

This interpretation allows us to more concretely define this concept. In our view, it should include, on the one hand, skillful, clever, able actions to repel an attack or to defeat an enemy and, on the other hand, the choice and implementation of imaginative measures to deceive the enemy. Both components are interrelated, they complement each other, and they ultimately provide the opportunity to provide surprise in the employment of men and equipment and, at the same time, to create the conditions to carry out a staggering strike and the broad maneuver of fire and subunits.

Proceeding from what has been said, we can consider the following definition as the one that meets the most varied requirements: **military stratagem is the art of attaining surprise and creating favorable conditions for accomplishing missions with the least expenditure of men, equipment and time.** It goes without saying that all of this depends on the commander's (serviceman's) personality, first of all, on his ability to think creatively and ingeniously, to foresee the development of events, and to bring to fruition the planned methods and techniques of the combat employment of men and equipment and also measures to deceive the enemy.

The experience of the Great Patriotic War confirmed this. By way of illustration, various methods and techniques for bringing surprise pressure to bear against the enemy were used in an offensive. This was achieved, in particular, through attacks that were carried out against locations and at times when the enemy was not expecting them. Both their forces and their operating techniques varied. They were often selected along inaccessible axes, locations that were unsuitable for attacking troops (across ice, swampy areas, heavy underbrush, etc.). The Fascists did not expect attacks at night or at dawn and also in other limited visibility conditions (fog, rain, snowstorms and blizzards). In a number of cases, a shift to the attack without artillery preparation with tanks moving at maximum speed or, on the contrary, without the use of tanks, promoted success.

The troops often attacked after an unexpected maneuver along inaccessible terrain and emerged on the enemy flank or in the rear. Thus, in October 1944, the 126th Light Rifle Corps surmounted 70 kilometers of marsh and swamp that the Hitlerite command authorities had no doubt was impassible. Having completed a flanking movement, corps units cut off a road that was very important to the enemy, forcing him to retreat in panic, having abandoned his heavy weapons.

Great significance was imparted to skillful fire for effect against the enemy. In the process, they attempted to employ a variety of methods that allowed them to catch the Fascists unawares while inflicting the maximum losses on them. Artillery preparation for an attack, as a rule, was begun at a time that seemed to be most unsuitable, in the evening or just at the break of dawn, and also at night. They varied its duration and structure.

A combination of aircraft, artillery and combined-arms subunits were employed in order to achieve surprise. As a rule, they carried out preliminary airstrikes on the eve of the attack, during the day or at night. Artillery

preparation did not always precede battalion operations. It was also begun in the action of battle, sometimes even several hours after subunits went over to the attack, as it was, for example, during the capture of bridgeheads on the Visla River in January 1945. In a number of cases, great effect was achieved when powerful rocket artillery fire strikes were carried out not at the end (to which the enemy was already accustomed), but during the middle of the artillery preparation for the assault.

As combat practice attests, the most unexpected thing for the enemy was the imaginative operations of our troops in the depth of his force disposition. Say, tactical air assault landings, sending out advanced detachments, raiding parties and flanking detachments, and setting up ambushes, as a rule, simply stupefied the enemy. Their effectiveness was often increased thanks to the use of various military stratagem techniques, such as attacking a target at maximum speed with headlights blacked out or with switched on searchlights, camouflaging their equipment like the enemy's equipment and movement behind enemy columns, etc.

Even skillful small subunit actions provided appreciable results. Thus, the landing of a small (reinforced rifle company) tactical air assault at night in January 1942 gave the enemy the impression of the beginning of an encirclement and forced him to change the direction of his retreat. In the process, the Hitlerite formation fell under the blows of the 43rd Army which was attacking from another direction, and the enemy suffered significant losses.

The ability to tie down the enemy in sectors that were not being attacked largely promoted the attainment of success on the main axis in a number of cases. As a rule, the troops carried out a similar task on a wide front with a limited number of men and equipment. In order to convince the enemy of the reality of false intentions, various methods and techniques of military stratagem were widely used. That is a characteristic technique of battle.

In battle, a guards rifle battalion company received the task to tie down the enemy on the right flank at a nameless height. They managed to achieve the task thanks to the continuous aggressiveness of subunits which systematically conducted fire against the discovered targets from various directions, they simulated preparations of a start up position for an attack, reconnaissance organ operations, and prepared artillery fire positions. They accentuated the redeployment of men and equipment to make the false axis convincing. So, the feint shift to the attack, which was preceded by artillery preparation in front of the company's front, did not cause the slightest suspicion among the enemy that this was a deception. The attack on the other flank was totally unexpected for the enemy.

I want to note that the experience acquired during the war years does not contradict the definition of military stratagem that has been presented and permits us to establish the interrelationship of the methods, techniques and goals for its use in battle (See Diagram 1.).

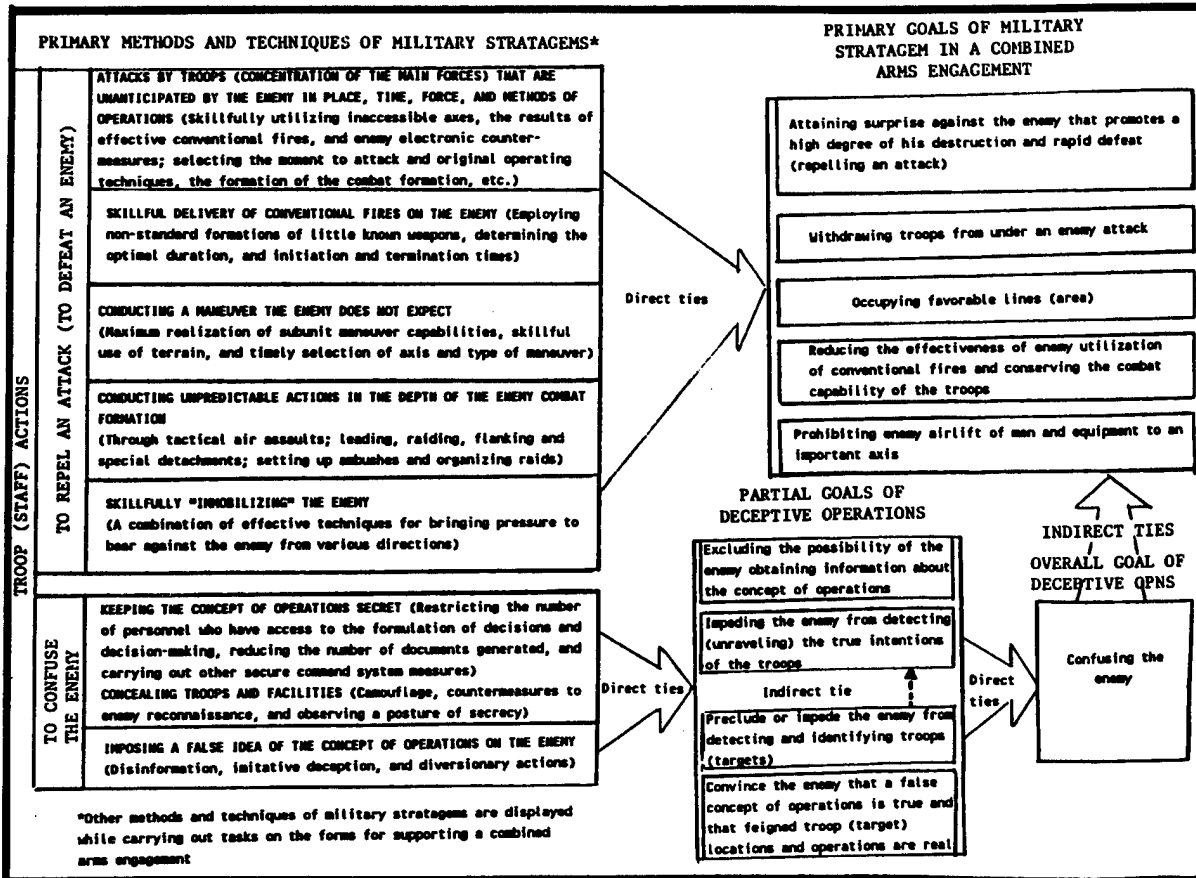

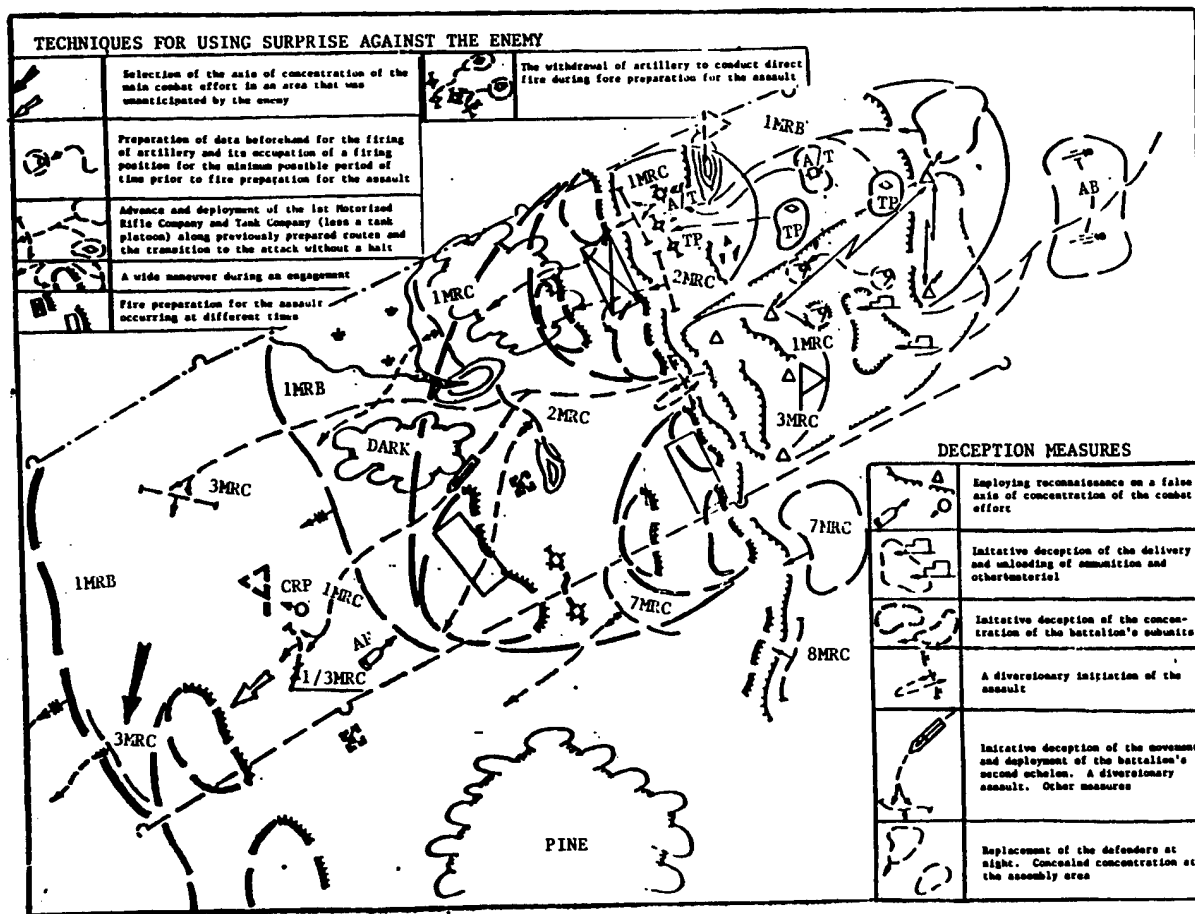

- Key:
1. MRC—Motorized Rifle Company
 2. MRB—Motorized Rifle Battalion
 3. AB—Artillery Battalion

4. CRP—Combat Reconnaissance Patrol
5. AF—Assault Force
6. A/T—ATGM [Antitank Guided Missile]
7. TP—Tank Platoon

From it, it is first of all obvious that the operations techniques of men and equipment to defeat the enemy (repel an attack) and the various forms of deceiving the enemy are interrelated. They complement each other and provide the capability to attain the main thing—surprise.

In a modern combined arms engagement, you cannot count on success without their comprehensive use. In the process, commanders must consider that the quality of combat equipment, reconnaissance systems, precision-guided weapons, and automated command and control systems permit the conduct of surprise attacks by troops and weapons in a matter of minutes and even seconds. And the technical systems that are in the inventories of subunits and units of the various services and branches of troops can be used for the realization of the most varied measures to deceive the enemy. Let's look at them as an example of a decision adopted by the commander of a motorized rifle

battalion in an offensive during the course of a single command and staff exercise (See Diagram 2).

1st Motorized Rifle Battalion's main efforts are being concentrated on an inaccessible axis where the enemy is not expecting aggressive operations. Gun crews calculate data beforehand for firing from guns and mortars but they occupy primary gun positions for the minimum possible period of time prior to initiating fire preparation for the assault. The enemy is destroyed with less intensity on the false axis of concentration of efforts. But on the real axis—they open fire with a small time delay (5-10 minutes) but it is conducted for a longer period of time and with greater density. The weapons that are allocated for direct fire, are stealthily concentrated at some distance from the forward edge of the battle area [FEBA] prior to initiation of fire preparation for the assault and, from the first salvo, rapidly advance and deploy at firing positions to conduct fire against targets that have escaped damage and against newly discovered targets.

First echelon companies shift to the offensive using various techniques: 2nd MRC [Motorized Rifle Company]—from a position of direct contact with the enemy, 1st MRC with a tank company (less a tank platoon)—from the move with an advance from the depth along a previously prepared route. With the seizure of the first trench, a broad maneuver of subunits is envisioned with the goal of emerging on the enemy's flank and rear. Part of the men and equipment tie the enemy down using fire from a halt on the axis not being attacked.

The battalion's second echelon begins to advance after 1st and 2nd MRC's have seized platoon defensive positions on the FEBA. While utilizing terrain folds to the maximum extent possible, 3rd Company conducts a maneuver on the right flank at high speed to attack enemy positions in the depth.

Steps are conducted to deceive the enemy. Specifically, during the night battalion subunits stealthily occupy a start point and maintain their previous level of activity. At the same time, radio discipline is violated in false areas of concentration of men and equipment to deceive the enemy. To do this, the brief appearance of combat and other equipment (with deliberately changed side numbers) on open sectors of terrain is permitted that confirms the buildup of subunits here.

Reconnaissance is increased on the false axis of concentration of the main efforts. The operations of reconnoitering groups and the delivery and unloading of ammunition and other materiel are imitated. And at the prescribed time, some of the forces feint going over to the attack. During the course of the engagement, up to a motorized rifle platoon advances from the secondary line to signify the entry into the engagement of the battalion's second echelon. These same men and equipment subsequently tie down the enemy with fire from a halt.

All battalion subunits participate in implementing measures to deceive the enemy. In the process, they utilize terrain protective and masking properties, individual and group protection systems, improvised materials, plant-manufactured mockups and those that they have made themselves, equipment movement imitating systems, thermal and infrared decoys, corner reflectors, etc.

Some of the men and equipment is attached to perform feints and other operations. For example, the advance and deployment of the battalion's second echelon are imitated by a motorized rifle platoon whose combat vehicles tow mockups of tanks and armored transport vehicles that have radar and thermal contrast.

They assume that the qualitative conduct of the proposed measures of military stratagem will promote the successful completion of the combat mission by the battalion.

We think that, with clarification of the concept of "military stratagem" and with the systemization of its

various methods and techniques, a combined arms commander's duty consists of filling it with specific content. In the process, all points of the concept of operations must be "permeated" with the aspiration to baffle the enemy, to place him in a dead end, and not reduced only to orders of deception measures in one of them. In our view, it is advisable to generally formulate them as a separate element of a decision and to completely reveal them in its other points.

From the Editorial Staff

The methods and techniques of achieving success in combat are quite varied. However, fundamental qualitative changes in the material base of armed combat are being advanced in a number of primary principles of combined arms combat—surprise and the employment of military stratagem. As a result, Colonel V. Orlyanskiy's attempts to reveal the mechanism for deceiving the enemy on the tactical level merit attention.

The magazine's editorial board hopes that Great Patriotic War participants, commanders and headquarters staff officers, professors of military academies and schools, and readers who have undergone combat tests in Afghanistan will supplement and deepen the author's thoughts and share their experience for attaining surprise in combat, mainly in tactical level subunits—the platoon, company, and battalion, especially while conducting a defensive engagement.

Footnotes

1. Lobov, B.N., "Voyennaya khitrost v istorii voyn" [Military Stratagem in the History of Wars], Moscow, Voenizdat, 1988, p. 27.

COPYRIGHT: "Voyenny vestnik", 1991.

Reconnaissance Ambush Parties

924C1786A Moscow VOYENNY VESTNIK
in Russian No 6, Jun 91 pp 55-57

[Article by Reserve Major S. Kasyanov, under the rubric: "Afghanistan: Combat Experience—in the Inventory": "Reconnaissance Ambush Parties"]

[Text] (The author served in the 40th Army in the positions of reconnaissance platoon and then company commander from August 1984 through October 1986)

Afghanistan, the 40th Army. On 23 September 1985, at 18:25 hours local time. A reconnaissance team, consisting of 14 men under the command of Senior Lieutenant A. Mikhalkov, was landed by helicopters in the rear area of a formation of "irreconcilables". The team began to stealthily advance to the designated area with the approach of darkness.

After covering approximately two kilometers, the patrols issue a signal: "There's a man on the path." The captured man turned out to be a bandit formation messenger. Totally stunned by his surprise capture, he reported the location of two enemy groups and agreed to lead one of them out onto the route of travel. The reconnaissance team members completed a march in the darkness and set up an ambush on a mountain road by 01:00 hours on 24 September.

And two trucks, that were traveling with their headlights extinguished, had already appeared at 01:30 hours. The soldiers killed 62 men with fire at pointblank range and with grenades and captured prisoners, 62 rifles, 50,000 rounds, and important documents. The intelligence information obtained by Sr Lt Mikhalkov's group turned out to be extremely valuable and permitted our commander to accurately plan and carry out subsequent combat operations.

Just what are reconnaissance ambush parties? According to the prescribed definition, they are organized, as a rule, to capture prisoners, documents, and models of enemy weapons and equipment. I will point out that the task of destroying the enemy inevitably accompanies them. In my opinion, their main distinction from fire ambushes consists of the need to conduct close combat, right up to hand-to-hand combat. If, let's assume, we must abandon the occupied position as soon as possible after an exchange of fire with the enemy in a fire ambush, on the contrary, reconnaissance team members decisively close.

While considering these specific features, subunits (motorized rifle, tank, parachute assault, ground assault, reconnaissance) that have been designated to set up reconnaissance ambushes need to be trained according to a special program. The experience of combat operations in the Republic of Afghanistan can render invaluable assistance here.

There ambushes were normally set up in the rear area of the opposing side, but sometimes also in its own troop formation. In modern combat, especially in the initial period of war while conducting a maneuvering defense, they can be placed on the flanks, in boundaries and gaps of defensive positions (defense areas) or in rear areas that are not occupied by troops.

It is difficult to select an ambush site. Here the main thing is favorable terrain conditions for cover, surveillance and conducting fire. In Afghanistan, they were most frequently located near the turns of roads and paths, exits from ravines, dry river beds, and at river crossings and bridges. The mountains promoted the concealment and surprise of operations, however, they were extreme impediments to maneuver and observation. Not more than 30-40 percent of the nearby terrain could be observed even from a successfully selected point.

A typical composition of an ambush—is a platoon, reinforced by several Kalashnikov machineguns, with an AGS-17 automatic grenade launcher or an NSV-12.7 heavy machinegun crew, and a combat engineer squad (team). One-two flamethrower crews have been attached to it in special cases. The reserve of ammunition and materiel they carry to assure autonomy of operations has been increased by a factor of 1.5-2 as compared to the normal reserve. For example, for rifles—two combat loads, grenades—three-four per person, the same number of RPG18 (RPG22) rocket-propelled grenades per platoon, a reserve of mines, radios of various types

for communications with the senior commander, aircraft, and within the subunit, water and dry rations for the entire period of the combat sortie [boyevoy vykhod].

The 40th Army headquarters had strict instructions with regard to ambush team strength, heavy weapons composition, and the ammunition reserve. Unfortunately, specific conditions were not seriously considered. Heavily weighed-down servicemen advanced slowly and tired very quickly.

The commander normally determined the place and time to set up the ambush, the procedures for fire destruction of the enemy and the explosion of mines, the sequence of operations during a clash with small or large bandit formations, the combat formation and the locations of the positions of teams (elements), the organization of security and reconnaissance, the march formation during the advance, actions during a surprise encounter with the enemy, measures to deceive the enemy, the size and time period for fortification of the positions and their camouflage.

Proper configuration of the battle formation was extremely important. Besides the teams listed in normative documents (attack, capture, and fire support), such independent elements as an armored group or mine subgroup were created in our unit. The role and place of the former has already been examined in articles¹ I will dwell on the latter in more detail. Its task was to blockade, using minefields, the proposed target of the attack and sometimes to also detonate mines to destroy the enemy. MON-50 [Antipersonnel Mine With Directional Fragmentation], OZM [Antipersonnel Fragmentation Mine], IMN [not found], and other models were used to do this.

The effect was significant when the mines were used with surprise and with imagination. For example, on the night of 13 November 1985, a 12-man reconnaissance team under the command of Lieutenant S. Machulin completed a march into an area of a planned ambush. The enemy observation post was destroyed during the advance and the route it was located near was mined.

At dawn, the team set up an ambush, killed 12 men, and captured a prisoner, documents, and weapons. The Mujaheddin showed us a camouflaged ammunition depot—it was also immediately mined. They once again organized an ambush alongside it. A total of 14 bandits were killed by mines set up by reconnaissance team members. The team, not without losses, was evacuated by helicopter.

About operations in an ambush. Advance to the location where the ambush is set up normally occurred by combined means: to the landing (dismount) area by helicopter (BMP [armored personnel vehicle], BTR [armored transport vehicle]), further—on foot. The distance from the destination totaled, as a rule, 10-12 kilometers. Otherwise, the enemy was able to quite confidently assume the location of the ambush.

They landed (dismounted), as a rule, 10-12 minutes before dusk. It was as if the subunit walked off into the night. Having completed the march under the cover of darkness, it regrouped at the base area. Final reconnaissance of the ambush set up area and the routes to advance to it were conducted during the course of the following day. Team, element, and fire support missions were made more precise and coordination was worked out. But sometimes they had to move to the designated area without occupying a base area.

The strictest blackout and sound masking procedures were observed during all movements. The march formation was structured while considering the specific conditions. Most often, they sent out forward and rear points, less frequently—side patrols. Having detected the enemy, they attempted to avoid an encounter with him and they entered an engagement only in an untenable situation.

Reconnaissance and security was especially painstakingly organized during the approach to the ambush location. The point patrols, which inspected the terrain while paying attention to the adjacent heights, rocks and other locations for concealment, moved out first. The advance guard moved after them, while continuing a more detailed inspection of the route and the adjacent area. Surveillance and local security were also organized in major forces.

When selecting an ambush location, they were normally guided by the principle—the least possible number of accessible approaches. It is best of all when there are

two—like an “entrance” and an “exit”. They mandatorily planned some sort of small path, a “black path” and sometimes more than one—for a concealed departure.

They deployed up to one third of the men and equipment at the entrance and exit, blocking the enemy. The remaining men and equipment were at a location selected to destroy the enemy at pointblank range and to capture prisoners.

Cases are known when the subunit commander did not create a killing zone but located the ambush along the Dushmani's route of travel. For example, this was done in canyons, ravines, and in river beds. They covered the entire column simultaneously when the signal grenades detonated. Steep slopes protected the soldiers from fragments and multiplied the killing power and psychological impact of the use of “pocket artillery”. Surprise close-range concentrated fire from all types of weapons completed the rout.

Frequently it subsequently turned out that many “souls” died with an assault rifle at full automatic or with an armed RPG grenade in their hands. We can explain why not a single shot rang out from their side only through the strong psychological shock caused by surprise and the ferocity of the attack.

This moment is the most advantageous to capture prisoners. A capture team rapidly closes with and disarms the enemy and inspects the dead in order to seize documents. An interpreter is absolutely necessary in an

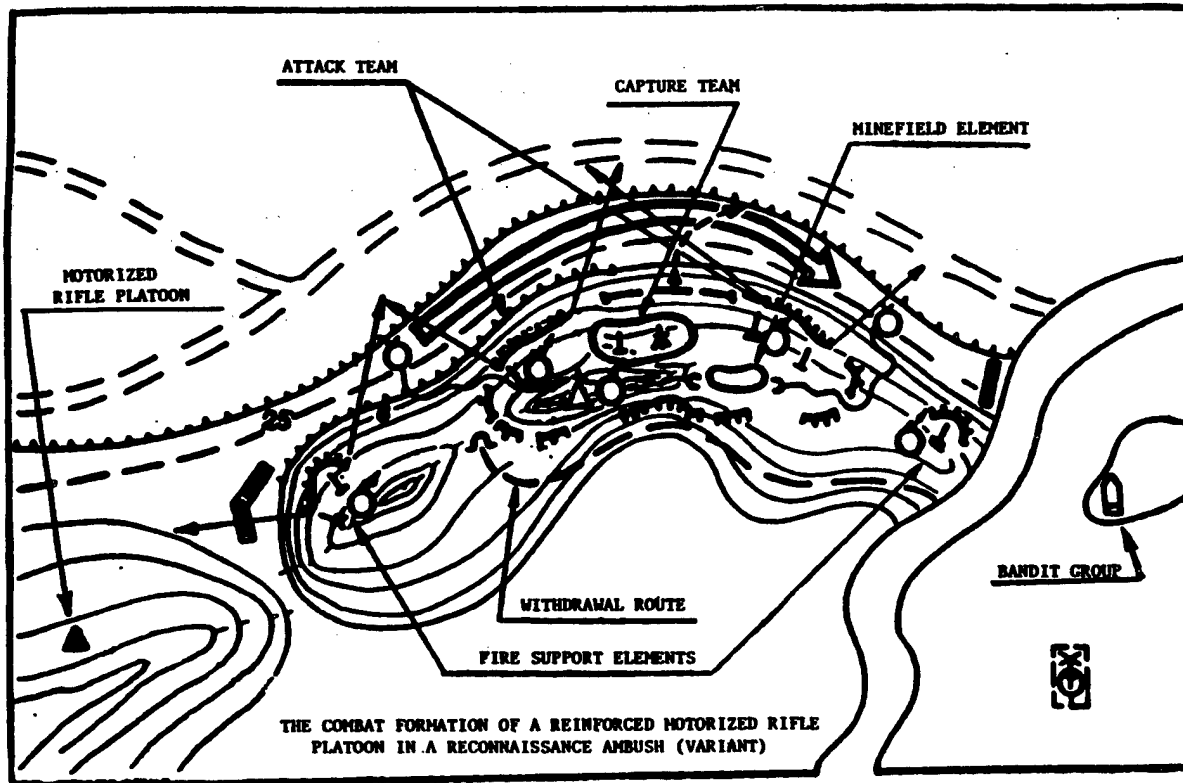

ambush because the first minutes and hours are the most valuable to "coax" information from prisoners.

A bit about the specific features of night ambushes. The location for them is selected before dark, positions and orientation points are planned beforehand, etc. The engagement itself is conducted at night. We used two of its varieties, so-called "dark" and "light". The essence of the former consists of the application of weapons exclusively with night sights and with silencers (PBS). Only the subunit commander fires cartridges with tracers for target designation. This type of ambush was used most frequently against small bands.

In "light" ambushes, the location where the killing zone is created was illuminated using various devices. All personnel fire tracers. Here the important thing is the proficiency of the reconnaissance team members who illuminate the killing zone location.

Yes, quite a few things are needed so that the ambush turns out to be successful: to deploy it in a concealed manner, to correctly determine the moment to open fire, and to anticipate enemy actions. Here each soldier's restraint, skill, and composure are important. But combat is combat. And the enemy, not sparing forces, is also striving for victory. It has occurred that an enemy that is superior in numbers has attempted to surround and destroy the reconnaissance team members.

Then the subunit has shifted to circular defense or has withdrawn from the engagement. In the first case, the teams (elements) have occupied previously designated positions at a prescribed signal. The helicopters and the armored transport vehicles were summoned at the same time. They destroyed the enemy using concentrated fire and prepared target designation for aircraft and sometimes for artillery at locations where the enemy has massed.

Disengagement and withdrawal were more rarely used. I see one of the reasons for this in the fact that, after an exhausting march it was difficult to count on a rapid break-off from the enemy, all the more so if the soldiers were "loaded down" based on the standards mentioned above.

At the same time, I understand that these are the specific features of Afghanistan: both its mountainous conditions and our superiority. In a struggle with a strong, well-equipped enemy (with his superiority), the only way to preserve the reconnaissance teams' forces is an immediate withdrawal.

The space in a magazine article does not permit me to dwell in detail on the other numerous nuances of the organization and conduct of reconnaissance ambushes. I hope that these bits of combat experience will become the support of officers and sergeants in training subunits.

FOOTNOTE

1. Kravchenko, A., "Gruppa v zasade", [A Team in an Ambush], VOYENNNYY VESTNIK, No 7, 1989.

Support to Airborne Assault Landing

92UM1073C Moscow VOYENNNYY VESTNIK
in Russian No 8, Aug 91 pp 62-64

[Article by Colonel M. Buzik, candidate of military sciences, under rubric "To Assist Artillerymen": "In Support of an Assault Landing"]

[Text] Among other missions, units and subunits of missile troops and artillery perform the mission of neutralizing enemy air defense in the penetration corridor of a tactical airborne assault force and on the flanks in support of the assault landing. To determine the scope of fire missions, it is necessary to determine the number of air defense weapons capable of engaging the helicopters carrying the assault force. If we assume they are distributed evenly in the enemy division defense zone, then the ratio of the number of air defense weapons capable of opposing an overflight by helicopters carrying the assault force to their total number will equal the ratio of the area of the potential engagement zone by some one weapon (we will denote it by the symbol "j" and will call it the involvement zone of the j-th weapon) to the total area of the division defense zone.

The involvement zone is characterized by width and depth. Depth is taken to mean the length of the assault force flight route over enemy territory. But calculations to determine the width of the involvement zone of air defense weapons are the most complicated. It depends on helicopter flight altitude, which will be from several meters to several kilometers depending on conditions.

The following relationship usually is used for calculations:

$$S_j^{inv} = 1.5\xi + J,$$

where S_j^{inv} is the width of the involvement zone of the j-th air defense weapon (km);

J is the width of the assault force penetration corridor (km);

ξ is maximum ground range calculated for an Improved Hawk battery (platoon) from the formula:

$$\xi = \sqrt{D_{fire}^2 \left(1 - \frac{V_r^{*2}}{V^2}\right) - H^2},$$

where D_{fire} is the range of battery fire (km) (defined as the maximum range of acquisition of helicopters by the AN/MPQ-51 target tracking and illuminating radar according to the relationship $D_{acq} = 95$ times square root of H (for cases where $D_{acq} < D_{max fire}$);

V_r^* is minimum radial speed at which helicopters approach the battery (km/min);

H is helicopter flight altitude (km).

For short-range surface-to-air guided missiles and AAA, maximum ground range is calculated from the formula:

$$\xi = \sqrt{D_{\text{fire}}^2 - H^2}$$

As applied to European conditions, calculations of the width of the involvement zone of unit air defense weapons under this methodology are given in the table.

Air defense weapons	Width of Involvement Zone (km)						Mean width of involvement zone
	Assault Force Flight Altitude (m)						
	30	150	1000	2000	3000	4000	
Improved Hawk	16	20	32	39	40	40	
Improved Chaparral	-	11	11	10.5	9.8	8.7	10
Vulcan	7.8	7.8	7.8	7.1	6	- *	8
Stinger	10.2	10.2	10.2	9.6	8.9	7.6	10
Gepard	7.8	7.8	7.8	7.1	6	- *	8

*Note. A dash signifies that involvement of this air defense weapon in engaging helicopters carrying an assault force is precluded or unlikely.

Data in the table indicate that the assault force flight altitude has a most substantial influence on width of the involvement zone of the Improved Hawk SAM system. Averaged values can be taken in calculations for other tactical air defense weapons.

Unfortunately, calculations according to this methodology do not consider the possibility of a maneuver of enemy air defense weapons in the course of battle. Meanwhile, in the opinion of foreign military specialists, in the course of battle a formation commander may concentrate them to cover individual important axes or installations and also move some of them forward (by battery or platoon) in compressed time periods for intercepting the most dangerous airborne targets from new directions.

Taking advantage of capabilities of future standardized airborne radar reconnaissance systems such as J-STARS, the enemy may not only detect the assault force at the moment of its takeoff, but also constantly track its flight. Results of calculations show that depending on the distance between the staging area for the airborne landing and the landing zone, the flight of an assault force will take 25-35 minutes at cruising speed (200 km/hr). Counting the time for determining the helicopters' flight direction, decisionmaking by the division commander, and assigning missions to air defense subunits for a maneuver to move up to positions, 15-25 minutes will remain.

An analysis of the maneuver characteristics of tactical air defense weapons shows that the Improved Hawk or Improved Chaparral SAM system will not manage to complete a maneuver to the penetration corridor in that time. The Stinger portable SAM system will be in combat formations of motorized infantry and tank companies. Consequently the most likely will be a maneuver

of Vulcan and Gepard self-propelled AAA mounts, which require 1-2 minutes for leaving old positions and setting up new positions.

Consequently, in determining the width of the involvement zone of these air defense weapons it is necessary to allow for its increase toward each flank by the amount of a possible maneuver to the assault force penetration corridor, i.e., the distance they cover in 10-20 minutes. It is fully understandable that this value will depend on the depth of the tactical assault force landing as well as on the condition of terrain and roads in the area occupied by the enemy, time of year, time of day and other factors.

We recommend using the chart shown to determine the width of the involvement zone and the number of self-propelled AAA mounts in it with consideration of their possible maneuver.

We will give one version of a calculation. Let us assume it is necessary to determine the width of the involvement zone and expected number of Vulcan self-propelled AAA platoons with consideration of the possibility of their maneuver to an assault force penetration corridor with a landing zone 120 km away from the staging area for the airborne landing (L). Terrain in the enemy disposition is moderately rough and the road network is poorly developed.

We draw a horizontal line from the point on the axis marked "120" until it intersects with the chart line for the Vulcan self-propelled AAA mount under roadless conditions. Dropping a perpendicular from the point of intersection to horizontal axes S_j^{inv} and N , we determine the width of the involvement zone of the Vulcan self-propelled AAA mount along the S_j^{inv} axis to be 18 km and along the N axis the expected number of Vulcan self-propelled AAA platoons is 7 (we round off only toward the larger side).

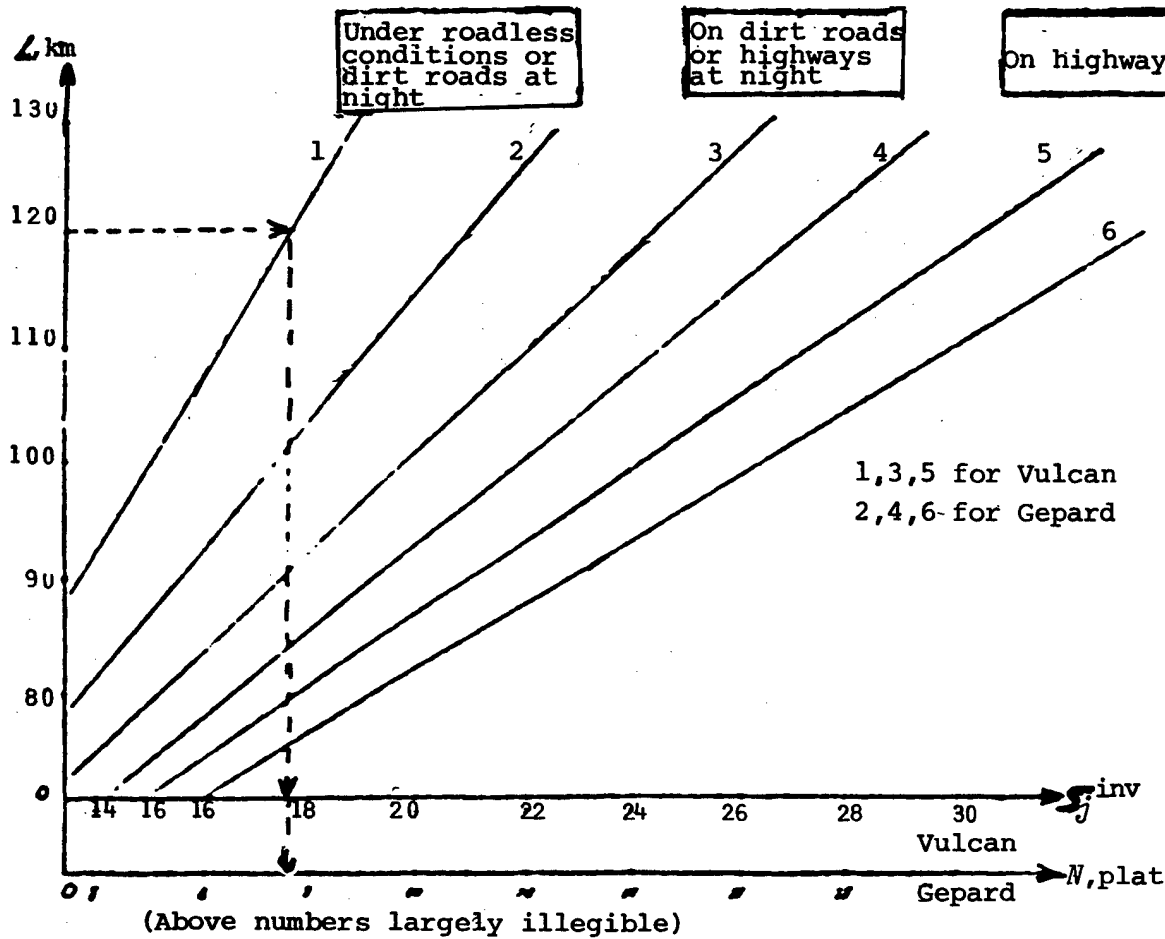

Use of this methodology by artillery staffs in engaging enemy air defense weapons in support of an overflight of a tactical airborne assault force will permit taking enemy opposition into account most fully and performing calculations in a minimum time.

The expected number of enemy air defense weapons to be engaged in support of the overflight of the tactical airborne assault force is given in the table.

Targets	Width of Involvement Zone, km	Expected Number of Targets in Involvement Zone				Distance From Front Line
		Mechanized Divisions (USA)		Motorized Infantry Divisions (FRG)		
		Not Counting Losses	Losses 20-30%	Not Counting Losses	Losses 20-30%	
Improved Hawk SAM batteries	40	3-4	2-3	2-3	1-2	15-20
Improved Chaparral SAM platoons	10	2	1-2	-	-	4-20
Vulcan SP AAA platoons	8	6-7	4-5	-	-	4-20
Gepard SP AAA platoons	8	-	-	8-9	5-6	5-25
Motorized infantry (tank) platoons at defensive positions	10*	Up to 24	Up to 17	Up to 18	Up to 12	Up to 20
Total		32-37	24-27	28-30	18-20	

*Note: Width of involvement zone determined based on Stinger (Fliegerfaust-2) portable SAM systems attached to motorized infantry (tank) subunits.

In Maneuver Defense

92UM1073B *Moscow VOYENNY VESTNIK*
in *Russian No 8, Aug 91 pp 60-62*

[Article by Colonel (Retired) I. Bernatskiy, candidate of military sciences, docent, and Major S. Antonenkov: "In a Mobile Defense"]

[Text] The artillery field manual does not specify precisely how artillery attached to first echelon battalions will operate when holding intermediate lines in the course of a mobile defense. The fact is, each intermediate line will be defended in turn by first and second echelon battalions. It would appear that the corresponding article of the manual is best supplemented by an explanation that artillery is not attached at each subsequent line, but is assigned to support battalions defending on a given line.

Multiple resubordination of artillery in the dynamics of battle as well as the specific nature of actions on the lines and in the course of maneuver dictate certain features in command and control of artillery. For example, studies have shown that in a mobile defense command and control of artillery fire and maneuver tends toward an increased degree of centralization. This stems from the nature of missions it performs. What is meant above all is giving fire support to first and second echelon battalions in turn as they defend each defensive line or position, supporting counterattacks by reserves, and covering the disengagement and withdrawal of battalions from one line to another. The need for maneuvering artillery fire because of a change in axes of enemy attack also arises more often than under ordinary conditions.

As we see, artillery will perform many fire engagement missions in support of a combined-arms unit within the entire defended area. Consequently, from this point of view as well it is not always advisable to attach it to someone in a mobile defense. In our view, it is better to assign artillery subunits to reinforce battalions successively defending the next lines or positions and to control their fire and especially their maneuver centrally.

One might ask whether or not the staff of a regimental artillery group is capable of coping with such a mission (if it is established under these conditions). It is impossible to respond unequivocally inasmuch as there are insufficient personnel and equipment presently available to the regimental chief of artillery for performing it. It is apropos to recall here that at one time the Military Artillery Academy imeni M. I. Kalinin studied the question of establishing permanent artillery command and control entities. Unfortunately it did not attract the attention of appropriate echelons. Obviously the time has come to return to this problem once more, substantiate their makeup and technical outfitting in the motorized rifle (tank) regiment once and for all, approve it in practice and introduce it to the troops. In our view the makeup of the regimental command and control entity should include a reconnaissance platoon and signal platoon with necessary equipment.

A periodic change of battalions defending intermediate lines complicates artillery's coordination with them and maintenance of continuous command and control of artillery in a mobile defense. To ensure continuity of command and control under those conditions it appears advisable to set up two command groups in the proposed entity which are approximately equivalent in makeup and tasks to be performed and which exercise command and control of all artillery alternately. Before this entity is included in the T/O&E of regiments, these groups can be formed by redistributing a portion of reconnaissance and communications equipment of supporting artillery battalions. Their approximate makeup is shown in the table.

	Number of Groups and Their Makeup	
	I	II
Personnel and Equipment		
Mobile reconnaissance post	1	1
Command and staff vehicle	1	1
Motor vehicle	1	1
Laser rangefinder	1	1
Periscopic artillery aiming circle (PAB-2A)	1	1
Portable radio	2	2
Wire communications equipment		
—TA-57 telephone set	2	2
—P-274M field cable	5 km	5 km

Now let us turn to the placement of command groups and their displacement in the course of battle. Experience has shown that it is probably most advisable to dispose one group at command and control facilities on the first line and the other at the second line simultaneously with the organization of defense here by first and second echelon battalions, and that it is best to displace by leapfrogging, i.e., to every other line. Just what are the advantages of this method over others?

First of all, there is no disturbance in continuity of command and control during displacements of one command and control facility to the next line as there is, for example, in the "successive" method.

Secondly, each command group is constantly with one and the same combined-arms subunit throughout the battle, which will ensure maintaining artillery's close, continuous interworking with them.

Thirdly, more time remains for each group to organize reconnaissance and fire control and to restore combat effectiveness at the next lines. Refer to the figure for possible methods of placement and displacement of command and control entities (facilities) in a mobile defense as well as certain time indicators.

It is quite obvious that the maneuver of artillery subunits and displacement of artillery command and control entities (facilities) must be tied in closely with operations of combined-arms subunits and with each other. As

Nature of Actions and Indicators		METHODS OF PLACEMENT AND DISPLACEMENT OF COMMAND GROUPS		
		I "SUCCESSIVE"	II "ALTERNATING"	III "LEAPFROGGING"
Conditions of Displacement		Entire makeup of command & control entity is on first line and displaces successively from line to line	Two command groups are initially at first line together, then they displace to each successive line in turn	Two command groups are disposed on different lines at beginning and during battle and displace by leapfrogging
Diagram of Displacement of Artillery Command Groups [ry-command group]				
Time & Sequence of the Functioning of Command Groups	1 Combat Work Displacement			
	2 Combat Work Displacement			
Period of Disruption of Command & Control Activity		030 - 100	NONE	NONE
Need for Establishing Coordination		ON EACH LINE (WITH A TIME SHORTAGE)	ON EACH LINE	ONLY BEFORE BEGINNING OF BATTLE
Time for Restoring Combat Effectiveness		NONE	145 - 150	205 - 210

noted earlier, this task can be done most effectively by the constant disposition of command groups together with battalions of corresponding echelons. Therefore, in addition to the usual questions, in organizing command and control of artillery in a mobile defense, the regimental chief of artillery determines the makeup of both command groups (personnel, supplies, transportation) and procedure for their initial placement and displacement as well as from which points and on which lines artillery fire and maneuver will be controlled, and by which groups. It is also necessary to indicate to the command groups specifically with whom to establish or maintain coordination at each line, the fire and maneuver control signals, and the procedure for establishing and maintaining communications with higher, subordinate and coordinating commanders and staffs.

In addition, it is advisable to inform each command group of the mission being performed by the senior commander's assets both on approaches to the regimental defensive area as well as ahead of each defensive line and on the flanks, targets to be engaged by massed, concentrated and barrage fire of division artillery, lines for remote mining of terrain and so on.

In connection with the fact that in preparing and conducting a mobile defense a need arises to plan not only

the maneuver of artillery subunits, but also the displacement of command and control entities (facilities) to each line, there will be a need to perform more calculations than under ordinary conditions and update them more frequently, often in extreme situations with an acute time shortage.

It is difficult to get by here without use of advanced automation equipment. Before it is widely introduced to the troops, it is advisable to have developed methodologies on artillery staffs for performing calculations on programmable microcalculators. In the general case they can include an algorithm, program, table for distribution of initial data in microcalculator memory registers, and operating instructions. A special need for their use arises in updating the planning for a maneuver of fire subunits, which is connected with the need to take into account a multitude of factors influencing artillerymen's readiness time at the next lines.

Experience confirms that developing such methodologies (operational-tactical tasks) requires no special knowledge or great inputs of time, but their use permits elevating the staff officer's work efficiency in performing calculations by an order of magnitude compared with using an electronic keyboard computer without a program.

In conclusion we will note that questions of command and control of artillery in a mobile defense unfortunately have not been sufficiently covered in our guidance documents. Considerations and recommendations expressed in this article unquestionably require a practical check in field training exercises and command and staff exercises. Wide involvement of military educational institutions, scientific research establishments, and commanders and staffs at all levels also is necessary in further developing these questions inasmuch as the success of troop operations in a modern defense, especially in case of an enemy surprise attack in the initial period of war, will depend on resolving them.

COPYRIGHT: "Voyenny vestnik", 1991.

Design Features of BAZ-6953 Artillery Tractor

92UM1204A Moscow *TEKHNIKA I VOORUZHENIYE* in Russian No 3-4, 92 pp 17-18

[Article by Lieutenant Colonels V. Aksenov and A. Korchmenyuk and Major A. Poskachey: "The BAZ-6953 Tractor: Design Features"]

[Text] The BAZ-6953 Truck Tractor, developed based on the BAZ-69501 chassis hardware, assemblies, and parts, was designed to tow artillery systems and trailers with a total weight of up to 15 t, and also to transport army cargoes weighing up to 10.5 t.

The BAZ-6953's power plant consists of two KamAZ-740.10 V-shaped, four-stroke, eight-cylinder diesel engines with a total output of 310 kilowatts (420 horsepower). They are installed behind the cab in the engine compartment. Their systems (lubrication, fuel and air supply, cooling, and exhaust gas discharge) are not interconnected which insures the tractor's mobility even when one of the engines breaks down.

Fuel tanks (each with a capacity of 300 liters) are located on both sides of the engine compartment. Thanks to the presence of two distribution valves, fuel can flow to the engines from either one or from both tanks simultaneously. A mechanical drive, which consists of a control pedal, manual control levers, and two shutdown levers, and also a transfer and draw regulating system are used to control the supply of fuel and to stop the engines. The latter ensure the synchronization of the rotation of the crankshafts. We need to remember that when they are rotating at 950-1,050 rpm⁻¹ or when the engines are operating at idle (600 rpm⁻¹), the difference in the tachometer readings should not exceed 50 rpm⁻¹.

The tractor's transmission was manufactured based on a side power distribution scheme. It consists of two linkages and the same number of gear boxes, transfer case reduction gears, transfer cases, eight final drives and wheel reduction gears, and a gimbal drive.

Dual disk clutches with peripheral location of pressure springs have a common hydraulic drive and two pneumatic-hydraulic amplifiers. Adjusting rods have been

used to ensure that they are turned on simultaneously. Synchronization is monitored through tachometer readings: when the tractor begins to move, when first gear is engaged, the difference in engine crankshaft rpm's should not exceed 200 rpm⁻¹.

KamAZ-14 model mechanical five-speed transmissions have been installed on the BAZ-6953 tractor. They are equipped with two miniature inertial synchronizers to ensure smooth shifting (other than into first gear). Shifting is accomplished using a remote mechanical drive.

The transfer case reduction gears (cylindrical, triple-shaft, unilinear with a gear ratio equal to one) permit the transfer of torque from the gear boxes to the transfer case reduction gears. A power take-off box is installed on the right transfer case reduction gear from which a drum-type winch is put into operation. The operating length of its cable is 60 meters and maximum pulling force is 117.6 kilo newtons (12 tons of force).

The interchangeable transfer cases (two-phase, triple-shaft, cylindrical reduction gears) are equipped with interlocking differentials which provide a link between the two forward and also the two rear wheels of one side. The control drive is electrical-pneumatic. Gear shifting is carried out using pneumatic switches and interlocking of the differential using pneumatic switches. Air is supplied to them from the tractor's pneumatic system using electromagnetic pneumatic valves (three of their switches are located in the vehicle cab).

Shifting gears in the transfer cases is carried out when the tractor is at a complete halt and the gear box is in neutral. They turn off the non-operating side when the tractor is moving on one engine. To do this, they place the switch of its transfer case into neutral. They disconnect the pipes of the pneumatic switch and the interlocking differential switch from the tractor's pneumatic system. They put the side that is operating into the lowest gear.

Side transmissions (a parking brake drum is attached to the flange of the fourth drive shaft) are used to transfer torque to the wheel reduction gears at an angle of 90° and to increase the tractor transmission's total ratio. They are made in the form of a pair of conical gears that have been installed in a cast housing made from a magnesium alloy. The straight-tooth cylindrical gears of the wheel reduction gears are located in a cast steel housing. The wheel reduction gears of one side are interchangeable (the first with the second, and the third with the fourth).

Torque is transmitted between transmission assemblies using cardan shafts and joints of unequal angular velocities. The fork-flange of the differential shafts is made along with the wheel reduction gear drive shaft. Therefore, when disassembling the latter, they first disassemble the cardan (Hooke's) joint.

The tractor's welded frame consists of two channeled-section longitudinal spars which are connected by 11 cross-members. Each has openings: four to install the

side transmissions and two for the steering gear, and also two openings for installing the casings of the pendulum levers. Two towing hooks with latches are attached to the forward section of the frame and there is a trailer coupling device attached to the rear.

The independent suspension of the wheels consists of arranged longitudinal-torsion bar springs, cushions, upper and lower collapsible levers of a directional device (they are joined by hinges with a suspension bracket and with a wheel support), and with parts of fixtures and hydraulic telescoping dual-action shock absorbers. The latter are designed to reduce oscillation that arises when the tractor moves. Furthermore, the cushion begins to work along with the torsion bar after the wheel is shifted more than 1/3 of its dynamic movement.

Wide VI-3 brand 1300-530-533 size pneumatic tires equipped with an air pressure regulating system have been installed on the tractor's disc-less dismountable wheels. They pump from 0.1 to 0.4 MPa [megapascal] (1-4 kilograms per cm²) into the tires, depending on road conditions.

Steering consists of an angular transmission, a steering mechanism, a drive and its hydraulic amplifier. The wheels of the first and second axles are steerable. The angular transmission is a conical reduction gear that permits the transfer of torque at an angle of 90° from the steering wheel to the screw-nut-rack-sector type steering mechanism. The mechanical drive consists of a system of tie rods and levers. There are two NSh 32U-2 pumps in the hydraulic amplifier that have been installed in the engine output selection boxes and are tied in to the main line of its hydraulic system. Dual-action hydraulic cylinders are used as actuating mechanisms.

Two shoe mechanisms that are installed on the wheel reduction gears and a pneumatic-hydraulic drive that has three independent circuits, are turned on to operate the braking system. The first circuit actuates the wheel brakes on the first and third axles, the second circuit actuates the wheel brakes on the second and fourth axles, and the third actuates the mechanism for the parking brake system. There is a brake control valve to turn on the tractor's and trailer's dual-drive pneumatic system and there is a control valve with the appropriate connector heads for the single-drive pneumatic system.

The tractor has 24-volt single-wire electrical equipment. Four 6ST-190TRN batteries have been installed in the vehicle. The temperature of the electrolyte for each pair is automatically regulated from -7°C to +12°C. The generator system consists of two G-288E alternating current generators with an output of 1 kilowatt each and RR390-B1 contact-transistor generator regulators. There are special nozzles for the headlights and taillights in the tractor's spare parts kit for operations in the blacked out headlight mode (in the process, the articulated vehicle sign needs to be turned off).

The four-seat two-door cab is made from fiberglass with interior panel heat insulation. The windshields (two

sheets of glass encased in plastic with a conductive coating on them) have electric heating. The driver's seat is equipped with a torsion cushion mechanism and with a hydraulic shock absorber. It can be adjusted in the longitudinal and vertical positions to ensure seating comfort.

The cab's heating system is connected to the right engine cooling system. It consists of a radiator, two fans, and supply and discharge pipes. The flow of heated air is regulated by a valve.

An FVUA-100N-24 filtration device with a capacity of 90-100 cubic meters per hour has been installed in the cab. The tractor's metal cargo bed is equipped with a folding rear seat and with benches installed along the sides.

COPYRIGHT: "Tekhnika i vooruzheniye", 1992

CIS: AIR, AIR DEFENSE FORCES

Uncertain Future Facing Aviation Division in Byelarus

92UM1213A Moscow KRASNAYA ZVEZDA in Russian
4 Jul 92 First edition p 3

[Article by Lieutenant-Colonel V. Rudenko, KRASNAYA ZVEZDA correspondent: "The Fate of a Division: Like That of People, It Is Not Always Easy"]

[Text] The 226th Ground-Attack Aviation Division, which subsequently became the First Guards Stalingrad, Order of Lenin, twice Red Banner, Orders of Suvorov and Kutuzov Aviation Division, underwent its combat christening in May of 1942. Only a few of those who fought in it from the time of its formation lived to celebrate the victory in '45.

The fame of the First Guards Division, flying Il-2s at that time, which the Germans nicknamed the "Black Death," resounded over all the fronts. At times the division suffered large losses in the fiery skies over Stalingrad, the Kuban, the Crimea and Byelarus, and its personnel were actually renewed several times during the war. Despite this, it arose from the ashes and pounded the hated enemy.

The frontline fighters did not think, of course, that five decades later the division's fate and its future would once again be at risk. They feel that the division is going through a period today which can only be compared with the fighting at Stalingrad. It endured then and became the First Guards Division. Will it endure today?

"Wherever you meet the personnel, they always ask 'What is to become of us? Under whose authority are we?'" says Major-General Aviation A. Boldyrev, division commander. "What can you say to them when no

official clarification has been received from the Commander-in-Chief of the CIS Combined Armed Forces, the Main Staff of the Air Forces or the Ministry of Defense of Byelarus.

In Byelarus no one calls the servicemen occupiers, constrains any of their rights or urges them to take the oath of loyalty to the Republic. The leadership of the CIS Combined Armed Forces and Russia's Ministry of Defense have, therefore, not worried about the division until recently. Many people assumed that it would become a part of a republic army and form the backbone of its air force....

This would have been the right thing to do. The division has been stationed in Byelarus for 48 of its 50 years, after all. It pounded the Germans in the "Minsk Cauldron," liberated Orsha, Grodno, Lida and other cities and communities in the republic. Twenty of the airmen were awarded the title Hero of the Soviet Union for courage and heroism demonstrated in those battles. The Division produced a total of seven two-time Heroes of the Soviet Union, 71 heroes of the Soviet Union and 23 full holders of the Order of Glory. The name of two-time Hero of the Soviet Union L. Beda became legendary in Byelarus. More than 40 streets are named in honor of division airmen in the republic alone.

S. Shushkevich, chairman of the Supreme Soviet of the Republic of Byelarus, wrote in the book of honored guests: "I wish the First Guards Aviation Division the preservation of its traditions and successes in peacetime. The Supreme Soviet and the government of the republic will find ways to maintain the military formations, of which any power could be proud."

Nonetheless, it has become known that only one regiment from the formation will be included in the republic army in the process of being formed. The fate of the others and of the division itself is still unknown.

It should be mentioned that Belarus took into its armed forces only units outfitted with the most modern equipment, with a well developed infrastructure and good facilities. In addition, the focus was frequently not on the interests of the people or concern for maintaining traditions but a desire to grab the best for themselves. All of the best things are now being removed even from units which are not a part of the republic army.

Captain M. Krysin, chief of a regimental objective control group, told me that an order had been received from the Ministry of Defense of Byelarus to turn over a new objective control system to one of the republic's aviation regiments.

Financing, fuel allocations and the assignment of recruits to units which are not a part of the republic army are being reduced by the day and will apparently be halted entirely in the near future.

Difficulties with the supply of fuel, oil and spare parts had to affect the fulfillment of flight training plans.

Although the division still managed to achieve one of the highest accruals of flight time in the air force, the intensity of the flight work has dropped markedly of late. It is no longer a matter of perfecting flight training but one of maintaining basic flying skills.

Alarm and concern about this were expressed by Marshal of Aviation I. Istygo, Hero of the Soviet Union, Colonel (retired) D. Kaprin, Major (retired) S. Apraksin, Jr Lieutenant (retired) F. Obukhov, full holder of the order of Glory, and other former frontline fighters who recently visited the Division. Unfortunately, their fears are not groundless.

Lieutenant-Colonel A. Golubev, senior division inspector, says that "the level of flight training for the personnel is the same today as before the war. There was no fuel then, either, there was not enough spare parts, the equipment was repaired.... In order to feel like a fighter a pilot must fly on a regular basis, but we get into the air once a week at best. Even then, what are the flights like? We must not deviate either to the right or to the left, as though we are carrying not bombs and missiles but bowls filled to the brim with borshch. When the squadron flies, it is always in 'skilled file,' aircraft after aircraft at intervals of two-three minutes. We penetrate air defenses in the same way. In a real situation all of the aircraft would be shot down. It is like making a hole in a wall, putting a cat on one side and a bunch of mice on the other and letting the mice go through one at a time. The veterans have told how they too flew in parade formation. If you fell out of the formation, you were punished, even to the point of being court-marshaled. And they suffered unjustifiable losses. Why repeat those errors?"

Lieutenant-Colonel Golubev is absolutely right when he says that we must not forget the bitter lessons of the last war and take the route of simplification. The commanders who arrange the flights according to the training level of the flight personnel are also right. And today, unfortunately, it does not allow for actively perfecting the complex kinds of training. Enough follies have been committed due to inadequate training and overconfidence.

The airmen can see no prospects. They live from day to day and do not know what awaits them tomorrow. They are, therefore, sometimes more concerned with personal matters than with service interests. At the Lida garrison alone 328 families are without housing. The number is around 1,000 for the entire division. Major I. Agapov, Captain A. Tkachenko, Sr Lieutenant A. Bogachev and many other pilots, navigators and aviation specialists in the division told sad stories about housing ordeals. Some of them, despairing of finding any kind of housing in town, are living in subsidiary premises right at the airfield or converting barns and garages into living quarters. One can assume that the situation will grow even worse following the withdrawal of yet another air regiment from Germany.

On 26 May the first stone in the construction of a post with 800 apartments was laid at Lida. It is being built by a Western company. Many of the aviators are pinning their hopes on this post. Whether they are justified will depend upon the fate of the division.

Housing, pensions.... All of this is unquestionably very important. When an individual is discharged, however, he gives up his beloved profession and parts with his dream. This is also a big problem, said Lieutenant-Colonel S. Buryakov, Captain N. Kachuk, Sr Lieutenant B. Pshenichnykh and other aviators.

"It is a shame to find yourself superfluous and unneeded after serving in the military 20-25 years," says Major Yu. Kovalchuk, a flight commander. "I still have confidence in the division's future, though. The division simply cannot be disbanded, putting the highly skilled specialists out onto the street. We do not have enough such formations for that."

"Disbanding the division would be the same kind of barbarism as the disbandment of the grenadier, hussar, Semenov and other regiments which were the elite of the Russian army back in '17," Colonel B. Shalukhin, division chief of staff, says. "Today we are discussing restoring them, while lightly giving up no-less deserving or renowned units and formations. Have we truly learned nothing except destruction and frenetic action"?

There have still been no official directives on the Division's disbandment. But nothing is known also about the division's fate. And so, the personnel worry that the current reorganization of the armed forces might prove more destructive for the division than even the Battle of Stalingrad.

Everyone is aware that during the period of reduction of the armed forces, it will not be possible to save many of the celebrated and famous units and formations. Many factors, some of them extremely important, have to be taken into account, however, in addition to their merits and traditions. One understands and accepts this with his brain. But still, still....

Incidentally: Right now a commission headed by Major-General of Aviation B. Stepanov is at work in the division. Much will depend upon its conclusions.

CIS: NAVAL FORCES

Profile of Surface Effect Ship 'Zubr'

*92UM1207A Moscow KRASNAYA ZVEZDA in Russian
18 Jun 92 First edition p 2*

[Article by Captain 3rd Rank V. Maryukha: "'Zubr', Son of 'Dzheyran'"]

[Text] The Zubr and Dzheyran surface effect ships that were produced by one of the design bureaus could be called "brothers" if there was not an enormous—an entire generation—difference between them.

When Zubr came out onto the pier area near Baltiysk for the first time, a seamen's rumor in an instant ascribed all of the conceivable and inconceivable achievements and shortcomings to the latest ship. There was more mistrust like in any new equipment. All the more so, this is understood if you consider that Zubr is a ship that is not a ship, an aircraft that is not an aircraft, and still the largest in the world in its class. Even the "omniscient" JANE'S reference book reports practically nothing about it.

We should be happy that there are still sectors where we are "ahead of everyone on the planet." And primary in the construction of SES—surface effect ships (or, as they still say, with the dynamic principle of support), native shipbuilders and sailors hold back these types of ships and boats from the moment they appear. Yes, they're just not convinced that we are not giving in to our own priorities here.

Just like with Dzheyran, Zubr's path from the first sketches to the first time it put to sea was long. They could work out far from all the parameters on models, therefore the lead model required numerous finishing touches that frightened the navy. But in 1988, three years later than planned, Zubr was still accepted into the Navy inventory. Four such assault ships received "residence passes" in the Baltic and three in the Black Sea Fleet. Of the four Zubrs that have been laid on the building slips at St. Petersburg, the navy will obviously receive another three—financing has been terminated for the last in the series. Nearly 42 million rubles have been saved in prices as of 1 January 1992. But what will the sum of the losses be if work in this direction is terminated?

But then again, as they told me at the Main Shipbuilding Directorate, it has been a long time since the Zubrs which the navy already has, sailed over the surface of the sea. First of all, shortcomings were discovered during the time of combat operation which place in doubt the 16-year service period set forth in the project. The plant is prepared to eliminate these shortcomings but everything once again is firmly fixed on the lack of resources. Secondly, there is neither fuel nor oil, and some components and spare parts kits are manufactured in Ukraine. And, thirdly, and this is perhaps the main thing, professionals must serve on these ships. Otherwise, the Zubr's fighting qualities will remain on paper.

In contrast to American and English SES's, designed in missile and commando versions, Zubr was not designed for speed runs toward foreign shores. Its primary purpose—is landing assault forces to support ground forces' combat operations on coastal flanks. That's why Almaz TsKMB [Central Maritime Design Bureau]—creator of the Dzheyrans and Zubrs—which has been driven onto a starvation diet by the lack of navy orders, is currently preparing to produce not combat ships but a surface effect steamship. I am confident that this ship is also needed and that it will find a buyer. But if the "son" of Dzheyran does not leave an "heir," what will the Russian navy be left with?

Technical specifications for the Zubr Class ship with the dynamic principle of support (surface effect ship):

1. Dimensions (in meters) along the metal hull:
length—57.3 width—25.6 height—21.9
2. Total displacement—550 tonnes.
3. Speed: maximum—63 knots (approximately 113 kilometers per hour), cruising speed—55 knots (approximately 100 kph)
4. The air cushion is created by four blowers and is maintained by a flexible skirt.
—Propulsion devices—three air fans.
—Power plant—three main gas-turbine engines.
5. Sailing range—300 miles (more than 550 km) (without cargo—1,000 miles)
6. Fuel reserve—56 tons
7. Autonomous operations—5 days (with an assault force—1 day)
8. Crew—31 men, including four officers and seven warrant officers
9. Armament:
missiles:
—Igla-M portable antiaircraft systems (4)
—unguided rockets
artillery:
—AK-630 artillery pieces—2
10. Assault force capacity:
—three tanks, or 10 armored transport vehicles, or 360 naval infantrymen.

CIS: REAR SERVICES, SUPPORT ISSUES

Central Finance Directorate Chief Interviewed

92UM1200A Moscow KRASNAYA ZVEZDA in Russian
30 Jun 92 First edition pp 1, 2

[Interview with Lieutenant-General Vasiliy Vasilyevich Vorobyev, chief of the Central Finance Directorate, by P. Altunin, KRASNAYA ZVEZDA correspondent; place and date not given: "The Priority Is on Social Problems"]

[Text] This is how Lieutenant-General V. Vorobyev, chief of the Central Finance Directorate defined the main task of his service in an interview with our correspondent.

[Altunin] Vasiliy Vasilyevich, a lot of water has flowed under the bridge since the last interview with you in our newspaper. At that time you talked about the serious problems in financing the troops and providing them with ready cash. Has anything changed in this context?

[Vorobyev] The situation remains complex. The continuing economic crisis with its inherent decline in

output volumes of products and services, inflation, and severance of economic ties limits the state's capabilities for material support of defense. In these conditions, the financial situation of the armed forces remains extremely complex. The military budget for the current year, as before, has not been approved. Financing of the troops and naval forces since the beginning of the year has been accomplished in a manner which has been used only during wartime—month by month.

There is a chronic shortage of funds allocated by the Russian government for maintaining the army and navy. The armed forces are experiencing serious problems in paying for food, clothing, and related gear. There is often nothing with which to pay for energy resources, communications services, and transportation services, that is, everything without which the life, activities, and combat readiness of the army are inconceivable.

We associate certain hopes for improving the financial situation of the armed forces with adoption of the military budget for 1992. The draft budget, on which parliamentary hearings were recently held, calls for a further reduction in military spending. In comparable prices, the reduction will be 10.1 percent compared to 1991. The planned volumes of defense appropriations until the end of the current year are based on a weighed analysis of the situation taking shape in the country and the army, a phased approach to cuts in the army, and the priority nature of the social problems of service members.

We understand the complexity of Russia's economic situation; therefore, we are asking for the army only the minimum necessary amounts, without which its normal functioning and implementation of social programs are impossible. A more major reduction in military spending, as some of our economists are proposing, can have negative consequences not only for the armed forces but also for the country as a whole.

[Altunin] You spoke of the priority nature of financing social programs compared to other military budget expenditures. What specifically is being done in this context?

[Vorobyev] As was already reported in the press, on 6 June of this year the Russian government adopted important and urgent decisions on increasing the pay and allowances of service members. They are being implemented in two phases.

On 1 June, the pay and allowances of service members, as well as the wages of workers in the budget sectors of the national economy, increased 1.8-fold. On 1 August, the existing pay for rank increases as follows: 1,000 rubles [R] for a warrant officer; R1,700 for a lieutenant; R2,300 for a major; and R2,700 for a colonel.

Taking into account the implementation of these decisions, the pay and allowances will increase 2.3- to 2.4-fold for officers, warrant officers, and extended-service military personnel and 1.8-fold for compulsory-service personnel. Thus, beginning 1 August 1992, a

platoon commander in the Ground Forces will receive up to R5,200, a company commander about R7,000, a regiment commander up to R9,800, and a division commander up to R12,000. We know these decisions are welcomed with enthusiasm in the military units.

[Altunin] Talking about military duty with officers of the Central Finance Directorate, associates of the editorial office heard a lot about how much you personally, Vasilii Vasilyevich, and many other officials had to exert efforts for these decisions finally to take place.

[Vorobyev] Yes, you are right, it was extremely difficult to get the decision on increasing pay and allowances adopted. The paradoxical nature of the situation was that the Supreme Soviet, its Commission on the Budget, Plans, Taxes, and Prices, and the government of the Russian Federation as a whole supported our proposals, profoundly understanding the essence of the problems and the troubles. But there were people in certain structures of administration who sincerely believed that if an officer of the armed forces receives pay for his labor at the level of an auxiliary subway worker, this is quite normal, and pay of R70 for the rank of an extended-service sergeant, R240 for a lieutenant after 4-5 years of training, and R360 for a colonel with 25 years of service is quite enough of an incentive for military service with all its rigors and to ensure that the Russian Army being created is manned with highly qualified and competent people.

Only thanks to joint efforts based on unified approaches to the problem were we able to find a solution acceptable to all. I would like to use this opportunity to express appreciation and gratitude to the president, the government, the Supreme Soviet of the Russian Federation, Minister of Defense General of the Army P.S. Grachev, Minister of Security of Russia V.P. Barannikov, Ministry of Finance V.V. Barchuk, and other leaders of the ministries and departments for understanding the needs of service members.

I respect your newspaper, but its pages sometimes contain inaccuracies and an unclear understanding of some of the issues being raised. In a number of the newspaper's articles, individual leaders, often having nothing to do with solving the problems of social protection of service members or who are incapable of solving them effectively, pass off as their own personal achievements the results of intensive labor of certain structures of the government and the Ministry of Defense. It is a shame that journalists do not consult the officials who are directly involved with these problems when preparing articles on this topic.

[Altunin] Unfortunately, that happens...

The editorial office has received many letters from service members from "hot spots" in which they complain about their deplorable existence and simply horrible social conditions.

[Vorobyev] Indeed, problems of providing additional social protection to service members serving in "hot spots" have worsened, since Russian service members and their families experience serious physical and moral burdens there and often suffer in the material context.

Today there are difficulties in manning military units located in the Transcaucasus, the Baltic region, and the Republic of Moldova. One of the reasons for this situation is social, since service members often are forced to leave their families behind in other regions, often in private housing. And those who have dared to take them with them constantly fear for their relatives. There are places where the safety of the personal property of service members is not ensured, particular during shipment.

In order to provide additional social protection for personnel serving in these areas, the Ministry of Defense together with the Ministry of Foreign Affairs and other interested departments have prepared the appropriate proposals, which are presently being considered by the government.

[Altunin] An analysis of letters to the editor indicate that the so-called "transportation" problem of service members has particularly worsened recently. This is associated with trips, scheduled leaves, and shipments of household goods during changes of assignment. Is anything being envisioned to overcome these difficulties?

[Vorobyev] Of course, there is an urgent need to take immediate decisions. At the current price for tickets, many officers and warrant officers servicing in remote areas of Russia cannot afford to travel with their family on leave, and during reassignments a considerable portion of the family budget goes towards paying for the shipment of personal items. Thus, it costs more than R20,000 to send a 5-ton container to Vladivostok, for example. Is this right? After all, service members do not choose their duty locations.

Appropriate proposals have been made in this regard by the Ministry of Defense and government of Russia. The issue of paying the full cost of sending containers with personal items from home to the station of departure has been resolved, since this has become an almost insoluble problem for an academy graduate even in Moscow.

[Altunin] Many of our readers are interested in the housing problem. What can you say about the financial aspects of solving it?

[Vorobyev] Financing the construction of housing for service members is a priority direction in the structure of capital investments of the armed forces. Not only is the percentage of expenditures for solving the housing problem in the total volume of spending for military construction increasing, but the absolute amount of these expenditures is also increasing.

Thus, last year nearly R3.5 billion were spend on building apartments and social and cultural facilities,

which was more than 60 percent of all appropriations allocated to the army and navy for capital construction, of which R2.6 went directly to construction of residential buildings. In 1992, already more than 75 percent of the budget appropriations allocated for capital construction in the armed forces is going to construction of housing and social and cultural facilities.

Additional steps are being taken to improve providing incentives for cooperative and individual housing construction. The currently existing free financial assistance to service members in the amount of 50 percent of the cost of cooperative housing or bank credit received for individual housing construction obviously is not solving the problem. At prices of R500,000 or more for a cooperative apartment, it is virtually impossible for a service member to come up with even half of that amount.

Considering that legislation is more progressive for workers of the national economy (by decision of labor collectives, financial assistance can be more than 50 percent, including full payment of housing), the Ministry of Defense has prepared proposals to the government of Russia on increasing the amount of free financial assistance to service members to 75 percent of the cost of cooperative housing or bank credit received for individual housing construction.

The new phase of economic reform and the next round of price increases begun this month will also require adjustments to be made in the near future to norms of monetary compensation to service members for housing rent. Otherwise this payment in the amount of R150-350 will lose its compensatory nature and cease to help service members without housing to solve the housing problem.

[Altunin] The difficulties of the initial phase of the transition to market relations are particularly difficult for the elderly and pensioners. What steps are being taken to provide social protection for veterans of the armed forces?

[Vorobyev] The recalculation of pensions granted earlier to blue- and white-collar workers and their families based on "current" wages beginning 1 May 1992 has made it possible to increase their incomes considerably. This resulted in a sharp change in the historically established correlation of the amounts of "civilian" and "military" pensions, which, in our opinion, cannot be considered normal. The pensions of individual military pensioners have even become considerably lower than those of blue- and white-collar workers laid off under similar conditions. In addition, increasing the pay and allowances of service members also resulted in a significant gap between the level of pensions of veterans discharged from military service and military pensions being granted for corresponding positions today.

In these conditions, proposals have been prepared for the government of Russia by the Ministry of Defense

together with other ministries and departments to eliminate these contradictions. Implementation of the proposals would make it possible to fully ensure social justice for more than 800,000 veteran service members residing on the territory of Russia, regardless of when they were discharged from military service. I should note that we are not yet finding the proper support in all economic bodies of the Russian Federation in resolving this matter, but we are confident that it will be resolved favorably in the near future.

Inasmuch as readers are also disturbed by the still-existing contradictions in pension legislation of the former USSR and Russian Federation, which affects the level of pensions of service members and, above all, invalids, war participants, soldier-internationalists, and their families, I want to report that this will be corrected with the passage of the corresponding legislative act of Russia on military pensions. The draft of this document is to be discussed in the republic's Supreme Soviet before 1 January 1993.

In conclusion, I would like to say that questions of social protection of service members are at the center of attention of the Ministry of Defense leadership. The draft concept of organizational development of the Armed Forces of Russia regards resolution of this problem as one of the chief goals of the military reform being conducted.

At the same time, much here depends on passage of base legislative acts determining the legal status of the armed forces and financing and material-technical support of their activities in the new economic and sociopolitical conditions.

As far as the Central Finance Directorate's direct involvement in preparing the appropriate normative documents on questions of social protection of service members is concerned, we attach and will always attach paramount importance to this work.

Technical Problems With Disposal of Nuclear Warheads

*92UM1170A Moscow NEZAVISIMAYA GAZETA
in Russian 17 Jun 92 p 2*

Article by Vladimir Belous: "Nuclear Warheads: What Do We Do? Good Intentions and Harsh Reality"]

[Text] The reduction of strategic nuclear weapons is among the issues being discussed at the Summit Meeting which is now taking place in Washington. The military-political aspects of this problem have been studied in adequate detail. Another of its important aspects—the purely technical—is considerably less well-known. Meanwhile, the most complex task from the technical standpoint has still not been totally resolved: the development of nuclear warhead destruction technology.

Disarmament

The breakup of the USSR and the formation of independent states on its wreckage, on the territory of which nuclear weapons are deployed, and some political leaders' claims to them has complicated the fulfillment of the obligations that the former USSR assumed. The complexity also consists of the fact that we must, in parallel and at practically one and the same time, conduct the reduction of strategic and tactical nuclear weapons on an unprecedented scale.

Turning to the history of nuclear disarmament, we need to note that there has been no such thing in the classical understanding of nuclear disarmament. The obligations of the parties, the nuclear weapons platform destruction procedures (missiles, aircraft and submarines), and the verification methods were entered in adequate detail in the treaties that have been concluded (including on INF [Intermediate-Range and Shorter-Range Missile Treaty] and START [Strategic Arms Reduction Talks]). At the same time, not a word is stated in the agreements about the elimination of nuclear warheads, and they contain no obligations whatsoever for their physical destruction.

Under this approach, the number of platforms and the warheads deployed on them which can come raining down on an enemy in one launch-sortie becomes the decisive criterion. The number of warheads located in warehouses is of secondary importance and so far has not been considered in the calculations. However, these assessments have increasingly come into contradiction with the tasks of genuine nuclear disarmament, especially when it was a question of the most numerous, miniaturized tactical nuclear weapons that are stored separately from their platforms.

Examination of the issue of the physical destruction of nuclear warheads and monitoring them would greatly complicate the process of the negotiations, which were progressing with difficulty even without that. After all, both sides are imparting special significance to the reduction of nuclear technology secrets, the specific features of the design of nuclear weapons and even the quantity of fissionable nuclear materials contained in each type of warhead.

George Bush's proposal on the elimination of tactical nuclear weapons was a surprise for many people. Earlier, in reply to repeated Soviet proposals to begin talks on this class of nuclear weapons, the American administration invariably repeated "no". What can explain this metamorphosis in the views of the American military-political leadership? While analyzing the international situation, many political scientists are arriving at the conclusion that if nuclear war breaks out in the next 10-20 years it will occur, not through the will of the politicians, but as a result of a lethal accident. Their fears have increased even more as a result of the breakup of the USSR and the attempt of some political leaders to obtain access to nuclear

weapons. The CIS's internal instability has become the main threat to nuclear security.

The dramatic events during the attempted coup d'etat in the USSR in August 1991 when, according to U.S. expert assessments, the role of the chance factor drastically increased, served as the immediate impetus for the U.S. President's announcement of his proposals. Therefore, the intention to secure the United States, to reduce the risk of the accidental outbreak of war, and also to ensure conditions for eliminating nuclear weapons on the territory of the former Soviet republics is the primary goal which permeates George Bush's announcement. In research that has been conducted at Harvard University, attention is directed to the great danger of tactical nuclear weapons "because such weapons are widely deployed and their detonation can be ensured even if you have comparatively insignificant technical skills".

The elimination of the Warsaw Treaty Organization, the revolutions in the countries of Eastern Europe, the unification of Germany, and the withdrawal of Soviet troops from Hungary and Czechoslovakia which created a fundamentally new situation in Europe also influenced the appearance of G. Bush's initiative with regard to tactical nuclear weapons. After conducting the reductions provided for in the Treaty on Conventional Weapons in Europe [CFE], the NATO-CIS correlation of forces will be 5.0:3.3 for the first time and could increase even more in favor of the West in the future.

The results of the Persian Gulf War, where the United States conducted full-scale testing of its latest weapons systems with conventional munitions which demonstrated high combat effectiveness, also did not play the last role.

However, these deep reductions give rise to the extremely complex problem of dismantling nuclear warheads and the utilization of weapons-grade fissionable materials exclusively for peaceful purposes. According to data from the Stockholm International Peace Research Institute (SIPRI), U.S. tactical nuclear forces number 7,922 platforms and 7,147 warheads. Similar forces of the former USSR are 13,759 platforms and 11,305 warheads. In the event the undertaken obligations are carried out, the following will remain in the inventory: the United States—1,300 aircraft and 1,800 aircraft bombs, Russia—2,560 aircraft and 3,100 bombs. Thus, Russia has to destroy nearly 8,000 weapons and the United States—5,500.

In the process, we need to consider that, in accordance with the START Treaty, the CIS countries and the United States must remove nearly 5,000 nuclear weapons from the inventory which, we hope, also will be eliminated.

The weapons destroyers will have to deal with devices with extremely high potential danger. There is a rule: if a man feels poorly or simply has not slept well—he doesn't go near a warhead. All of this is a legitimate reason for rejection and no one has the right to blame him for this.

According to expert assessments, the probability for a random accidental detonation of a nuclear weapon is $10^{-6}+10^{-7}$ per year. While considering the total number of them on CIS territory (nearly 30,000), this phenomenon could occur during the course of 30-300 years. Consequently, we have already stepped across the lower threshold of the danger range and must undertake decisive steps in order to significantly postpone it. The most realistic path is the reduction of the number of nuclear weapons with the strictest compliance with all safety regulations.

The experience of the nuclear states demonstrates that the dismantling of nuclear warheads must be conducted at those same plants where their assembly occurred. According to the assessments of prominent American Nuclear Physicist T. Taylor, a plant's daily production capacity for dismantling nuclear warheads will not exceed 6-8 warheads per day which is 1,500-2,000 per year. Consequently, the process of dismantling the warheads being removed from the inventory will take 10-12 years. The cost of transportation and dismantling in the process will total no less than \$2 billion.

The leadership of the former USSR had announced a quite strict schedule for destroying tactical nuclear weapons: Naval warheads—1995; anti-aircraft missile warheads—1996; nuclear mines—1998; and, nuclear warheads of tactical missiles and artillery shells—the year 2000.

In so doing, one other fundamental issue arises: what to do with the expensive fissionable nuclear materials? As we all know, highly-enriched uranium and plutonium are used in warheads. Highly-enriched uranium contains more than 90 percent of the isotope uranium-235 (it is a total of 0.7 percent in natural uranium). Plutonium is a man-made substance obtained from uranium-238 in special heavy water reactors.

According to the assessments of American experts, at the end of the 1980's, warheads in the USSR and in the United States contained nearly 100 tons of plutonium and 500 tons of uranium. The primary problem consists of the fact that the entire quantity of fissionable materials removed from the warheads should be used exclusively for peaceful purposes and should not be used, as it has been until now, in the development of new weapons. That leads to non-fulfillment of the requirement. We can illustrate this by the example of a Pershing-2 missile W-85 warhead that has been removed from the inventory in accordance with the INF Treaty. According to the assertions of Textron Defense Systems, the nuclear charge of this warhead can be used to equip a B-61 aircraft bomb. We need to assume that Soviet warheads are not an exception in this regard.

The task of utilizing weapons-grade uranium is comparatively simply solved by mixing it with natural uranium up to a 3-5 percent concentration. Fuel elements for AES [nuclear power plant] reactors is manufactured from the material obtained. According to the assessments of U.S.

experts, the cost of the uranium contained in half of the American nuclear warheads is nearly \$6 billion. Using the "mirror reflection" method which frequently assists Soviet experts due to our extreme secrecy, one can assume that the uranium contained in the warheads of the former USSR cost nearly the same amount.

Peaceful use of plutonium is a significantly more complex scientific-technical problem. One of the proposed ways to utilize it consists of mixing it with natural uranium to manufacture fuel elements. However, reactors of a special design, which to this day do not exist either in Russia or in the United States, are required to utilize this fuel.

The urgency of developing plutonium reactors is also explained by the fact that the continuous production of plutonium occurs in the operating process of industrial AESs. According to expert assessments, at the present time nearly 200 tonnes of plutonium has accumulated in the nonnuclear countries alone and the quantity of plutonium will reach 500 tonnes by the year 2000. Considering the situation that is developing, Japanese scientists have developed a design for plutonium reactors. Japan is already conducting the purchase of plutonium from various states which is causing a certain amount of alarm for the world community.

The problem of utilizing plutonium is also complicated by the fact that reactor plutonium may be utilized for the development of certain types of nuclear warheads. This makes the establishment of effective monitoring of all nuclear energy facilities by the International Atomic Energy Agency (IAEA) extremely urgent.

Opponents of the utilization of plutonium point out not only the complexity of its rational utilization but also its extremely high toxicity. According to their assertions, dispersing 1-2 grams of plutonium in a one square kilometer area makes this territory unsuitable for human habitation and the recultivation of the land will cost hundreds of millions. Therefore, a number of scientists propose mixing plutonium with nuclear reactor radioactive wastes which makes it unsuitable for future use with subsequent burial at special burial sites. However, besides the direct economic losses, we must consider that the half-life of plutonium is 24,000 years.

One other suggestion of specialists provides for the destruction of the warheads which contain plutonium using an explosion of a nuclear warhead in a special cavity made at a great depth. In this case, the destruction of the warheads will occur under the effect of high temperature and pressure and the partial fission of the plutonium and the subsequent vitrification of the entire radioactive mass by molten rock. There are also proposals on placing the plutonium into orbit beyond the Solar System using powerful rockets but they are not receiving any particular support for the time being.

Many scientists are leaning toward building special storage facilities to store plutonium under strict international control. At the same time, it is necessary to unite

the efforts of the scientists of the world's leading countries to develop economical and ecologically clean methods for its utilization and to develop highly reliable reactors that operate on plutonium. In the process, the prevention of the repeat military use of weapons-grade nuclear materials has practical significance only in the event that Russian and the United States, and the other nuclear countries after them, cease further industrial production of weapons-grade uranium and plutonium.

Siberian MD Chief on Improving Social Protection

*92UM1214A Moscow KRASNAYA ZVEZDA in Russian
7 Jul 92 First edition*

[Interview with Colonel-General V. Kopylov, commander of Siberian MD, by Captain A. Beklich, KRASNAYA ZVEZDA correspondent: "Siberia Pays Its Debts to the Military"]

[Text] Colonel-General V. Kopylov, commander of the Siberian MD, answers questions posed by our correspondent.

[Beklich] Viktor Andreyevich, we know that the administrations of Siberia's krays and oblasts have received for implementation the President of Russia's Decree On Measures to Increase Social Protection for Servicemen and Individuals Released From the Military Service. Have the Siberian servicemen felt the effect of this document?

[Kopylov] I would say this. The president's decree is being implemented in Siberia, although not as vigorously as we would like. Decisions have been adopted in Novosibirsk, Omsk and Kemerovo oblasts to reimburse servicemen for the cost of preschool facilities for their children. The Barnaul administration has extended to servicemen the right to air and rail tickets out of turn when going on leaves and temporary duty assignments. By decision of the city authorities the servicemen have been given priority status for the installation of telephones in their apartments. A social aid fund has been set up for servicemen in Kemerovo Oblast, and steps are being taken to find jobs for officers released into the reserve.

It was difficult to set up the system for implementing the decree locally, however. This was reflected—and is still being reflected—primarily in the fulfillment of the main point in the decree: the provision of the servicemen with housing and liquidation of the housing indebtedness.

[Beklich] Could you go into that in greater detail?

[Kopylov] As of right now the district is receiving around a quarter of what it is owed. I think that it will be difficult to liquidate the remainder of the indebtedness at the pace which has been set.

The situation is not bad in those krays and oblasts in which, even in the past, prior to the president's decree,

the administrations showed concern for the needs of the servicemen. The debt in shared housing construction has been completely wiped out in Tomsk and Kemerovo oblasts, for example. Incidentally, the latter is finding it possible to assign housing even to newly arrived officers. Altay Krai has liquidated more than 40% of its debt. I believe that Boris Nikolayevich Yeltsin's visit to Barnaul had something to do with this. The problem is being resolved fairly well in Krasnoyarsk Krai. In a number of cities in Novosibirsk Oblast, however, the number of apartments being allocated toward payment of the debt is very insignificant. Most of the 3,124 military families without housing are in three large areas; Omsk and Novosibirsk oblasts and Krasnoyarsk Krai. We are taking this fact into account and are not sitting idly by. We have our own, not unsuccessful housing construction effort underway in the district. All of the officers and warrant officers of a unit withdrawn from the Western Group of Forces were recently provided with apartments.

[Beklich] Everyone understands that the cities do not have unlimited possibilities. There was a reason why the decree issued by the president of Russia suggests another way out of the situation: the allocation of plots for the construction of individual homes.

[Kopylov] You know, it is a fairly simple matter when it comes to orchards and gardens. We allocate officers plots from our own land pool for the construction of dachas. Several hundred officers and warrant officers have already erected dacha-type structures. Others are using the land for raising gardens, and after the harvest they too will begin building dacha-type cabins. What the officers at the Omsk Garrison have done is a good example. They set up the Svetlyy dacha cooperative. mainly dacha-type cabins have been built on the plots. They built the cabins themselves, as a rule, but the units helped in whatever way they could.

I think that it is going to be extremely difficult for the officers to build cottages and homes, however. To the best of my knowledge, the cost of building a one-story cottage is more than one million rubles. An officer would have to work more than just a single decade to earn that kind of money. I doubt that the problem will be eliminated even if the serviceman takes out a loan and receives partial reimbursement. And so, the matter needs to be worked out.

From the editors: It is apparent from this article that where there is real concern for eliminating the military housing problem, possibilities are being found for liquidating the housing debt. In far from all areas of Russia, however, is the situation even as good as that in Siberia. What does this mean? Is it a disinclination to implement the president's decree, inefficiency on the part of local administrative bodies or the objective impossibility of paying off these debts in certain of Russia's krays and oblasts? This will be revealed in B. Yeltsin's scheduled meeting with the heads of those administrations.

For now it should be said that the situation with respect to those without apartments in the armed forces is worsening.

Problems of Reforming Russian Military Schools Examined

92UM1227A Moscow KRASNAYA ZVEZDA in Russian
8 Jul 92 First edition p 2

[Article by KRASNAYA ZVEZDA correspondent Major A. Yegorov in the column: "Military VUZ's in the Transition Period": "Are We Ready for Education Reform?"]

[Text] In the time when spring was about to turn into summer, the Novosibirsk Higher Military Political Combined Arms School was holding ceremonies celebrating its 25th year of existence. The holiday unfortunately came at a time when the Russian Minister of Defense signed an order calling for reorganizing the school into an engineering command type school. The news brought a sigh of relief to many officers, largely commanders and instructors of the military disciplines. Humanities instructors, who comprised the core of the Novosibirsk school, became quite disturbed, since that meant that they would have no future in that facility. The Cultural Department, which they had created as a way for the school to survive in the new environment, and the special courses—officer ethics, aesthetics, oratory—would of course be slated for elimination.

The school's chief, Colonel V. Kazakov, compared the forthcoming restructuring with refurbishing a pedagogical institute into a polytechnical institute. In this he generally has a point. For turning the Novosibirsk Combined Arms Political School, which possesses the same material base as a combined arms higher command school, into a combined arms command school, which would train non-specialist commanders—psychologist type teachers—would not be a particularly difficult task. Converting it into an engineer command educational institution involves major restructuring of the program, which would become one of fundamental instruction in mathematics, physics, theory of mechanics, and electronics, with the attendant requirement for millions of rubles to be spent for building a laboratory base, manufacturing facilities, and a complement of machine tools (with the price of the average machine tool running up to 0.5 million rubles), a practical skills section, etc. However, of cardinal importance to the Novosibirsk personnel would be the losses associated with the efforts devoted to the school's previous restructuring and the forced retirement of instructors who had been for many years the pride and joy of the VUZ.

The chief's view is that there is no need whatsoever for the platoon leader or company commander to possess any understanding of thermal imaging or, say, the principles involved in the shifting of gears in an infantry combat vehicle. This is of interest to a technician. The commander is supposed to manage: the BMP, platoon,

company. Therefore, what is required today is training a specialist possessing a wide range of knowledge, including teaching and psychology. What is not needed is a technocrat, a person who avoids contact with people, one who is at his best only in the midst of combat vehicles and often harbors a disregard for command responsibilities. Is this not understood in Moscow?

Colonel V. Kazakov's question could be rephrased: What is the principal advantage to closing a military psychologist school (which was the exact goal of the efforts made in the Novosibirsk Higher Military Political Combined Arms School)? Or: What does the school's restructuring as an engineering command school entail?

To seek an answer to the above questions, I paid a visit to the Special Department of the Novosibirsk State University.

While agreeing with the idea that the Army has a dire need for professional psychologists, P. Ryzhenkov, who is head of the Psychology Section, surprised me by stating that he is in favor of remaking the NHMPCAS [Novosibirsk Higher Military Political Combined Arms School] into a purely technical educational institution. It is P. Ryzhenkov's view that the level of instruction offered in the Military Pedagogy and Psychology Departments falls far below present standards. He claims that what is presented amounts to no more than scholastic exercises and formulas which are still permeated with ideology and are out of touch with the real world—even with psychology.

I heard virtually the same thing in Moscow during my visit to the Main VUZ Directorate of the Ministry of Defense. Yes, the Army does need psychologists, as attested to by the experience of other countries. However, the people who used to organize and continue to organize political schools are not psychologists. This is the view held by Major-General Yu. Goncharov, directorate deputy chief. He further feels that there are no real psychologists to be found among graduates of the Armed Forces Academy of Humanities, of its Military Pedagogical Department, in which plans call for concentrating in the near future the training of all practicing psychologists. The general said that it is planned to reform the department and overhaul the program so that graduates can satisfy the requirements.

In my view, the above measures will not suffice if the Armed Forces are to be supplied with the necessary number of psychologists, since specialists maintain that there should be one psychologist on duty in each battalion as a minimum. Nevertheless, I was given to understand in my conversation with Major General Goncharev that this is not the only concern with which the directorate is wrestling. The higher military school system is overloaded with other problems of much greater gravity and immediacy.

One of the most pressing problems involves the serious shortage of cadre in a number of military specialties

(amounting to more than 50 designations) caused by the division of the USSR and associated decimation of the unified system of VUZ's.

"Judge for yourself," said General Goncharov. "Of 162 schools and academies, 47 are now located beyond our borders. They include such splendid schools as the Military Engineering Radiotechnical Academy of the PVO imeni Govorov; the Kiev and Riga Higher Military Aviation Engineering Schools; the Minsk Higher Engineering Air Defense Missile School; the Kiev Higher Engineering Radiotechnical School of the PVO; the Kharkov Higher Military Engineering Command School of Missile Troops. These and other educational institutions were the pride of the Armed Forces. The disintegration of the Union deprived Russia of the opportunity of receiving replacements from the majority of aviation engineering schools (two schools remaining out of seven); from six artillery command schools (of which four remain); from six radio-electronic and radiotechnical type schools (of which four remain). Highly serious is the Navy school problem. Remaining in Ukraine are VUZ's that train unique nuclear munitions specialists. Russia presently has no schools of that kind. This means that they must be created. And this must be done at minimum outlay, utilizing the available training and material and technical base of schools related in structure or using schools that train the kind of specialist that is not in short supply. Military political schools may serve as an example."

Already undergoing restructuring is the Leningrad Higher Military Political School of the PVO, which is to become a PVO radio-electronic school, thus compensating for the loss of the Vilnius VUZ. The Military Command Academy of the PVO imeni Zhukov in Tver is taking on the function of training engineers along the lines of the Radiotechnical Academy of the PVO imeni Govorov, which has remained in Kharkov. The Novosibirsk NHMPCAS—the school we mentioned first in our conversation—is undergoing redesignation to train engineering command cadre for the motorized rifle troops and tactical reconnaissance troops.

The general said that another factor affecting the need for such radical changes in qualifications, other than shortage of engineering cadre, is associated with the recent decision made by the State Committee on Higher Schools and Technical Policy, whereby the Russian higher school is to adopt the multi-level system of education. Graduates are to be awarded the bachelor's and master's degrees. Certain adjustments will be made in the system, after which only engineering and engineering command schools are to be included. Command schools which offer a four-year course of study fall below international as well as Russian standards. (According to expert opinion, the engineering and general science instruction administered the cadets is deemed superficial.) The general stated that the only way to resolve this situation is to make a change to the five-year course of study, with the engineering command approach as a basis.

The above does appear to be reasonable. However, while I agreed with General Goncharov, it became clear to me that reformation of the higher school along the lines of the above measures involves more than that.

This being the case, what does the Main VUZ Directorate have in mind in the way of future military education?

General Goncharev revealed that dozens of highly interesting plans have been drawn up and hundreds of ideas analyzed, with the goal being the development of the higher military school. Included here for example is a proposal to enlarge the VUZ's, for the purpose of moving away from the old concept of a network of small schools in favor of building new and fairly large training centers with enrollment of 2,000 to 3,000 students. The underlying assumption is that school enlargement would afford the opportunity of making more effective use of capital outlays for developing the material base, thus providing the advantage of offering a higher level of instruction with its attendant professional training of cadets.

Another plan involves the construction of several very large centers (with enrollment as much as 5,000) offering a three-year course of study to supply officers to the Ground Forces. There would be no specialization. The cadets would receive a basic education, after which they would pursue professional studies in special educational centers, for armor, airborne, PVO, etc. Are these ideas not attractive? They are, but...

Are there funds available for this kind of project? Let us try to keep our feet firmly planted on the ground. On the same ground which has become so rutted with experiments. Is the country capable of taking on another burden? Something on the order of building new centers, to boot? Is the economy capable of establishing thousands of additional training slots in some schools, while eliminating the same number of slots in other schools, erecting barracks and other housing for hundreds of instructors and officer commanders, and setting up a laboratory and training base? Of course it is a pleasure to think up wonderful projects. To provide master's and bachelor's degrees and offer management specialist training. This is more easily said than done.

In the Main VUZ Directorate there is a consensus that the implementation of major plans is a matter for the future, for a later phase of education reform. For the present, it is necessary to make wise use of that which we already possess, moving ahead to eliminate superfluous schools and raise instruction to the command level, with the attendant conversions of schools to the five-year study basis. These measures are essential. Even they will cost a pretty penny: Conversion of all four-year VUZ's to the five-year basis means increasing the total employment by 20,000!

It would indeed be nice to have commanders who would be thoroughly skilled in handling both people and equipment. However, how are we to train this kind of specialist if we will have neither the methodology nor the capability of creating this methodology within the foreseeable future? Yes, one must feel sorry for energetic instructors who would be left with nothing to do. However, regardless of how one looks at the situation, it is impossible to make a practicing psychologist out of a party political worker without providing thorough retraining. This kind of instruction requires time, funds, and other resources. These are not available. In addition, there presently is a greater need for the engineer type specialist.

Pragmatism? Yes, pragmatism. But there is no alternative on the horizon.

Aide on Plans for Army Participation in Harvest

*92UM1232A Moscow KRASNAYA ZVEZDA in Russian
9 Jul 92 First edition p 1*

[Interview with Major-General S. Bogomolov, chief of staff for the direction of the motor-vehicle battalions of Russia's Ministry of Defense, by Colonel F. Semyanovskiy, KRASNAYA ZVEZDA correspondent, under the rubric "Harvest-92": "Military Trucks in the Grain Fields Once Again"]

[Text] A KRASNAYA ZVEZDA correspondent talks with Major-General S. Bogomolov, chief of staff for the direction of motor-vehicle battalions of Russia's Ministry of Defense.

[Semyanovskiy] Sergey Markovich, this year, for the first time, the motor-vehicle battalions are being assigned to participate in the harvest in accordance with a decree of the President of Russia, a government decree, an order from the Minister of Defense....

[Bogomolov] The main thing for us is the solid legal basis, which we hope will assure normal social protection for personnel of the "grain" subunits. I would mention one other important factor. An operational staff has been set up to be directly in charge of the harvest process in order to see that the harvest is conducted and the yield for 1992 is preserved. Its membership includes A. Ruts koy, V. Shumeyko and V. Khlystun. This staff, together with military structures, will coordinate operations of the 40 motor-vehicle battalions (20,000 vehicles) allocated for the purpose. They will be sent to 16 of Russia's kray and oblasts.

[Semyanovskiy] An decree, a statute, an order.... These documents contain a number of new provisions, which regulate the relations of local authorities, district command elements and farm leaders more rigidly. Could you comment on these?

[Bogomolov] Those in charge of the branches of Russia's armed forces are given greater independence at the organizational level. This is reflected first of all in the

fact that we will be concluding agreements and contracts with the administrations of the krays and oblasts and directly with the actual farm managers. In other words, while in past years the motor-vehicle subunits were dispatched by the military-administrative method, without precisely determining the situation in the regions, the distribution of personnel and equipment will now be scrupulously calculated. We hope that this will enable us to enhance labor productivity, eliminate unwarranted shifts of personnel and equipment and thoroughly to determine the economic feasibility of this or that decision.

In addition, a new system for organizing the production and financial activities of the motor-vehicle battalions and their relations with local authorities, mainly the farm managers, is being adopted. It should encourage them to analyze in detail their actual need for a specific number of motor-vehicle battalions consistent with the type of crop and transport volumes, as well as the opinions of the kolkhozes and sovkhozes. What did we have in the past? The head administrator would announce that two or three battalions should be allocated for an oblast or kray. This was the situation in Saratov, Vologda, Tambov and Orenburg oblasts, for example. The numbers would then turn out to be clearly overstated.

[Semyanovskiy] In the past the motor-vehicle battalions suffered financial losses, a fact reported more than once in KRASNAYA ZVEZDA.

[Bogomolov] I would add: not just financial but moral losses. Frankly, many local managers viewed the military drivers as a free work force. Here is bitter confirmation of that. Almost all of the battalions operated at a loss last year. Most of them were subsidized by the military department. Transport operations were greatly curtailed. Numerous stoppages occurred due to a shortage of fuel and lubricants. The work ultimately suffered as a result. Naturally, all of this affected earnings, the morale of the personnel and military discipline.

In our opinion, the new contract system will not only enable us to enhance profitability and effectiveness in the use of the motor-vehicle battalions but also force managers at all levels to establish financial responsibility for organizing the production operations of each motor-vehicle subunit.

[Semyanovskiy] What, specifically, is presently being done to see that the preparations and the harvest are conducted well?

[Bogomolov] This work has practically been completed in the forces. Meetings of officials of the districts and of those branches of the armed forces responsible for forming the motor-vehicle battalions have been held in the North Caucasus Military District. Selection of the personnel received special attention. The operational groups have been beefed up with experienced officers.

[Semyanovskiy] When will our specialists actually begin the work?

[Bogomolov] Unfortunately, there are some difficulties. Considerable ones at that. As of right now the battalion and company commanders have concluded fewer than 50% of the agreements out in the oblasts and rayons. A number of farms have curtailed their requisitions sharply, and some have refused our help entirely. This has happened in Voronezh, Samara, Saratov and Kursk oblasts and Altay Kray. There are many reasons; the

poor financial state of the farms, the high cost of equipment, fuel and lubricants, and so forth.

The first motor-vehicle subunits have already moved into the areas of the impending harvest, however: out of the Moscow Military District into Orlov and Lipetsk oblasts, for example, out of the Volga-Ural Military District into Samara and Orenburg oblasts, out of the Siberian Military District into Krasnoyarsk Kray and Novosibirsk Oblast....

INTERREGIONAL MILITARY ISSUES**Russian Munitions Seized by Kaitseleit**

92UM1220A Moscow ROSSIYSKAYA GAZETA
in Russian 27 Jun 92 p 7

[Article by Yuriy Stroganov in the "Serving Next Door" column: "Army Left to Mercy of Fate"]

[Text] A military train carrying munitions belonging to the Russian Army was stopped at night in Tartu. One of the freight cars was robbed.

"We lost 40 tonnes of projectiles," said Vice Admiral Yu. Belov, commander of the Tallinn Naval Base and chief of the Tallinn garrison, in commenting on the incident. "Where they were taken or how they will be used is something we do not know. If it had been a case of our having made an official transfer of munitions to the Estonian Ministry of Defense, then that would have been a different story. The train was stopped by members of Kaitseleit, which is an armed paramilitary organization supported by the authorities but of unknown subordination."

[Stroganov] Why was no resistance offered by the guard detail?

"What can a few armed soldiers do against hundreds of men armed with automatic rifles?" questioned Yuriy Pavlovich in answer to the question. "They would have simply shot them all. The shooting episode would be utilized in the campaign being waged against troops which come under the jurisdiction of Russia. Keep in mind that we are located on the soil of a foreign state, which in addition has passed a national property decree, which specifies that all our real estate, equipment, and armaments must become the property of Estonia."

"We offered to resolve the problem in a civilized manner, as it is being done in Eastern European countries. We received an answer: There has been no agreement here as there is there, and the troop presence here is unlawful and troop status that of occupiers. As a result, seizures of freight and property have become commonplace. Knowledge of the attack on our installation in Valga is widespread. Just the other day the naval yacht club—where 72 yachts were docked—was taken over. A truck carrying uniforms was stopped and the cargo stolen."

The alienation is deepening.

"A group of officers of our school has its future hanging in the balance," explained Colonel Sergey Porshnev, who at the Tallinn Higher Military-Political Construction School is deputy chief for work with personnel. "The school has virtually ceased functioning. However, we still have a new and excellent base worth about 330 million rubles, two installations. Their future is uncertain. There are no enlisted personnel there; officers themselves are keeping watch over the facilities."

The colonel himself has fallen into the same situation as many of his colleagues. Although he has lived his entire life in Tallinn, his family has no apartment, and his outlook is nothing short of abominable.

"Estonia has passed a decree embodying a quota, which specifies that a serviceman upon receiving a discharge into the reserve loses his entitlement to residence registration, and at that time is issued a passport valid for only one year, during which time he is to resolve his personal problems on his own," explained Vice Admiral Yu. Belov. "Finding somewhere to live after expiration of his permit is his worry. The municipal authorities do not wish to become involved in this. A survey we conducted indicates that about 1,200 families of officers would like to leave, but in Russia there is no place to which they can move. However, even if an officer does manage to find a way out and departs, we cannot reassign the apartment he vacated to another officer in accordance with previous practice, since the republic prohibits our placing anyone in the empty apartment."

The Tallinn garrison is still intact. However, the powerful political and social pressure being exerted is causing it to fall apart. It still officially comprises the naval base, a motorized rifle division, border troops detachment, and division staff of troop PVO [Air Defense]. However, it is not receiving any recruits as replacements; strength in some units has dropped to 17 percent. Combat readiness is deteriorating. The instruction schedule has taken a turn for the worse. Opportunities for using the training grounds are limited. Patrol service in the garrison is virtually nonexistent. On top of that, food provisioning is beset with difficulties: Estonia announced that as of 1 January it would no longer supply the foreign army with food provisions. Russian Army enlisted personnel are now forbidden to visit the city unless accompanied by commissioned officers. Military vehicles may not make a move without first obtaining permission.

"The situation being what it is, we must definitely resolve three major problems: setting—once and for all—specific time frames for withdrawal; determining our status; and deciding the property issue," said Yuriy Pavlovich. "This requires the personal intervention of the President of Russia."

Impact on Servicemen of Estonian Currency Exchange

92UM1209A Moscow KRASNAYA ZVEZDA in Russian
2 Jul 92 First edition p 2

[Article by Colonel V. Gavrilenko, Colonel M. Ziyem-insh, and Captain 2nd Rank V. Gromak: "Rubles No Longer Valid, Our Soldiers Still Lack Kroons"]

[Text] For three days, starting with 20 June through 22 June, from 9 o'clock in the morning until 10 at night, 66,000 authorized persons in Estonia exchanged their rubles for kroons. Everyone except servicemen could make the exchange.

Vice Admiral Yuriy Belov, commander of the naval base, had the following to say:

"Rubles could be exchanged for kroons in the Tallinn Naval Base only by women and children of servicemen registered in Estonia. Commissioned officers, warrant officers, conscripts, laborers, and civilian white collar personnel—everyone living aboard ship or in a dormitory—still have no kroons. We did attempt to have their rubles exchanged for kroons via field banks, but the government of Estonia does not recognize these banks. We requested the Russian government to incorporate field banks into the Bank of Russia as branches. The problem is under consideration. It is still not clear how military units are to deal with the particular Estonian institutions relative to payment for municipal services.

"Still up in the air is the question of disbursements for servicemen in the form of pay, leave payments, and temporary duty allowances; this issue was brought up some time ago and at all levels by the authorities of the Tallinn Naval Base in light of introduction of the Estonian monetary unit anticipated at that time."

Colonel Viktor Vodoliev, motorized rifle staff officer, stated the following:

"During the time of monetary reform, every resident of Estonia could exchange 1,500 rubles into kroons at the ratio of one to 10, that is, he would receive one kroon for every 10 rubles. Russian Army servicemen on duty on Estonian soil had to wait until literally the last hour to determine whether they were eligible to make the exchange. We were finally given the 'go-ahead.' This became possible after Estonian Prime Minister T. Vähi and Bank of Estonia President S. Kallas had made a trip to Moscow where they apparently arrived at an agreement with the Russian officials relative to setting up financial and economic arrangements to go into effect after the introduction of the Estonian monetary unit. This still left many questions unanswered, with the principal one being how the servicemen are to be financed in the future. The fact is that the abovementioned sum of 1,500 rubles as converted into kroons falls below the minimum pay for July. The latter, on the basis of the rate of exchange of the kroon as set by the Bank of Estonia, amounts to 2,000 rubles.

Colonel Vladimir Menshikov, financial service deputy chief of the NWGF [Northwestern Group of Forces], made his remarks:

"We have never seen any situation like the one faced by the Northwestern Group of forces: The Estonian kroon has been put into circulation; the Lithuanian litas is next; and the time is not far off when the Latvian lat will come into being. How are the military finance agencies to operate under these conditions? We are awaiting specific instructions on this score from the Central Finance Directorate. We are awaiting the receipt of guidance documents. As of the present, there is only one thing that is clear: The entire structure of the finance agencies must be overhauled. Even I—a member of the group of forces

finance service—cannot make an official trip to Estonia, simply because I cannot purchase a return ticket. I have no Estonian currency in my possession."

Lieutenant General Mikhail Bevz, NWGF chief of rear services, has this to say:

"What have the NWGF rear services done so far to soften the impact on the Russian servicemen by the republic's introducing its national monetary unit? Russian rubles continue to be the medium of exchange in all mess halls servicing restricted-entry military installations located on Estonian soil. All commissioned officers, warrant officers, and civilian personnel of military units will be able to use rubles to pay for food items made available under the usual supply system. Kindergartens sponsored by the medical service of the group of forces will also be able to pay in rubles for food items from military stocks."

We in addition telephoned the Central Finance Directorate. We were informed that the Ministry of Defense had dispatched a commission to the Baltics. Its mission includes the resolution of urgent problems created by introduction of the Estonian monetary unit. A complete resolution of the financial relations between Estonia and RF [Russian Federation] troops stationed on the republic's soil cannot be effected in the absence of a number of agreements to be made at the international level. Let us hope that these agreements can be effectuated in the near future.

The RIA has reported that the Bank of Estonia and the Central Bank of Russia have signed an agreement stipulating a procedure to be followed for performing transactions between the two states relative to the introduction of the Estonian kroon. These transactions will be carried out via a system of credit transfer to be set up in both banks and financed by Estonia in the amount of 50 million kroons and by Russia in the amount of 500 million rubles.

New 14th Army Commander Accuses Moldova of Massing for Attack

92UM1249A Moscow KOMSOMOLSKAYA PRAVDA in Russian 7 Jul 92 p 1

[Article by A. Khantsevich, KOMSOMOLSKAYA PRAVDA correspondent: "The General Speaks With a Soldier's Frankness"]

[Text] Chisinau—Major-General Aleksandr Lebed has commanded the 14th Army for slightly more than a week now. During his very first press conference in Tiraspol Lebed announced: "The army will retain its neutrality, but the neutrality will be of a different quality. It will be armed neutrality." This was enough for Chisinau to determine that it considered the new commander to be extremely unsatisfactory. Following the recently-held second briefing, the general was the object of a shower of complaints—some of them quite bold: "occupier," "henchman," "murderer"....

Just how did Aleksandr Lebed evoke such indignation? Quite recently, in August of last year, he came out resolutely in defense of the "White House" and democratic reforms in Russia. Perhaps he shocks people with his total disregard for diplomatic utterances. The general is accustomed to expressing himself in purely military terms. "The great power which I have the honor to represent has done enough traveling the circuit with hat in hand like goats after a carrot." But the army commander went even further: "After all that I have seen, learned and heard, I cannot regard legally elected President Snegur as a real president." According to Lebed, the current talks between Snegur and Yeltsin are nothing more than a bid for time to concentrate a powerful Moldovan offensive grouping on the approaches to the Dniester region. The general maintains that the army's military council possesses a vast amount of film, photographic and video material which he is prepared to make available to any commission, including an international commission. It shows, for example, that powerful artillery systems are being brought up to the Cosnita and Kochiyerskiy bridgeheads for shelling the cities of Tiraspol, Dubossary and Bendery; that 32 volunteer Romanian pilots have been transferred to an airfield near Beltsy to fly the MiG-29s based there.... Massive strikes with Uragans are planned against the Tiraspol airfield, the only one in the Dniester region, and against certain facilities and posts of the 69th Motorized Rifle Division....

General Lebed's conclusions are the following: "The shadow of fascism has fallen upon this bountiful land. I believe that the formerly united, enormous country should know this and recall what it took to break the back of fascism."

The army commander did not fail to affirm the fact that he was asserting all of this in his right mind. One must assume that Division General Ion Costas, Moldovan Minister of Defense, was also in his right mind when he spoke with journalists the following day. He refuted all of Lebed's accusations and added commentary on them. Moldovan President Mircea Snegur declared that "the provocational statements of General Lebed are nothing other than an attempt to provide the moral justification for a possible armed attack on the rest of our state, and actions designed to preserve the tensions.

UKRAINE

Kiev Officers' Union Protests Morozov Statements on Those Not Taking Oath

92UM1229A LITERATURA UKRAYINA
No 24, 18 Jun 92 p 1

["Ukraine in Danger": "Message From the Kiev Organization of the Ukrainian Officers' Union, Addressed to All Ukrainian Citizens"]

[Text] Russian has recently, finally, and aggressively set forth territorial claims on Ukraine. It is concentrating

troops redeployed from Germany, the Baltic republics, and Poland along a line bordering on our state. Throughout the southeastern oblasts of Ukraine and Crimea Russia has sent its leaders, government officials, and citizens (Rutskoy, Baburin, and Zhirinovskiy); they are spreading wild, anti-Ukrainian propaganda and openly advocating that the empire be revived. Unfortunately, neither the Ukrainian government nor the republic's law-enforcement agencies are reacting at all to these coordinated actions, which are aimed at disrupting the territorial integrity of our state.

As we know, many officers of Russian descent or background have not taken oaths of loyalty to the Ukrainian people and nation. The Ukrainian Minister of Defense has decided and determined that such persons be detailed by administrative orders to units of the Russian Federation's Armed Forces. For taking this action the esteemed Colonel-General K.P. Morozov was praised by a unanimous vote of those attending a plenum of the SOU [Ukrainian Officers' Union]. Soon, however, and obviously under pressure from certain government officials—and particularly from the mass media of Russia, as well as Radio Liberty—the minister clarified his order. The phrase "in accordance with the officers' wishes" appears in this clarification. But we know that almost none of them are willing or eager to leave Ukraine. And so let us ask you, our "elder brothers" the following question: In the future will you be serving in Ukraine without having taken an oath of loyalty to its people? After all now, our Armed Forces are not a legion of mercenaries. Only true and authentic Ukrainian patriots should serve in these forces.

We categorically reject and denounce the pressure exerted on the minister of defense, and we demand the most rapid possible discharge of those officers who have not taken the oath in line with the administrative orders of the Armed Forces of the former Soviet Union. After 10 June 1992 no oaths at all must be taken or accepted from them.

We also demand that full responsibility be placed on those officers who did take the oath but who—by their actions—are weakening military discipline, removing or wearing out equipment, armor or preparations, or are squandering them and taking them beyond the borders of our state.

We request that the minister of defense, when reducing the troop strength of our Armed Forces, categorically prohibit the relegation of Ukrainian Officers' Union members to reserve status: Such persons are true, authentic patriots of their Fatherland.

We appeal to the people on this matter which is such great importance for our Ukraine. The state's Armed Forces must exhibit diligence, bearing in mind that the nomenklatura which has remained within our government has certain ideas about inflicting a serious blow to our independence. Let's not allow any "Fifth Column" to penetrate Ukraine!

Glory to Ukraine!

[Signed] Executive Committee of the Ukrainian Officers' Union Kiev Organization

Cabinet Resolution Improving Servicemen's Allowances

*92UM1245A Kiev NARODNAYA ARMIYA in Russian
23 Jun 92 p 1*

[Ukrainian Cabinet of Ministers decree signed by Ukrainian First Vice Prime Minister K. Masik and Ukrainian Cabinet of Ministers Minister V. Pekhota, 16 June 1992, Kiev: "Ukrainian Cabinet of Ministers 16 June 1992, Decree No 332, Kiev, 'On Improving Pay for Servicemen of the Ukrainian Armed Forces'"]

[Text] The Ukrainian Cabinet of Ministers decrees:

1. That military commissariates at the residential location of servicemen who have been released from compulsory active military service and who, prior to being drafted, worked at enterprises, institutions and organizations, regardless of the form of ownership and management, will pay lump sum material grants in the amount of the average monthly wage which they received prior to being drafted but no less than the minimum wage stipulated by the law of Ukraine on the day of their release from military service.
2. To pay individual officers, army and naval warrant officers, and extended service military personnel, during their transfer to new duty locations, travel allowances in the amount of the monthly pay and, for each family member—50 percent of the monthly salary received by the serviceman. These servicemen are paid per diem in the established sums.
3. To establish field pay for servicemen, other than compulsory service military personnel, for each day of their stay outside the permanent location of their military units in the amount of 50 percent of the per diem standard.
4. For military formations to render assistance in conducting funerals and to compensate for material expenditures for services and the erection of memorials in the amount of 18 minimum salaries to families and parents of servicemen who died (were killed) during the period of their military service.
5. To Pay lump sum monetary compensation to the parents and adolescent (based on their status as of 1 January 1992) children of servicemen who died (were killed) or who are missing in action during the performance of military service, beginning from 1945 (except for servicemen who died, were killed or were missing in action during the Great Patriotic War) through 31 December 1990 (until the introduction of state mandatory personal servicemen's insurance) in the amount of 100 times the minimum salary at the time of payment of compensation.

A document certifying the fact of the loss (death) of a servicemen during the performance of military service is substantiation for payment of monetary compensation. In the event of the absence of such a document, the military commissariate takes steps to investigate the information to confirm the fact of the death of the servicemen while performing military service.

Begin payment of monetary compensation on 1 July 1992.

In 1992, conduct payment of monetary compensation to parents and adolescent children of servicemen who died (were killed) during the period 1945-1979 and, in 1993, to parents and adolescent children of children who died in 1980-1990.

Payment of monetary compensation is conducted by the military commissariates of various units at the residence location of the parents and adolescent children of the deceased (killed) servicemen.

Monetary compensation is not paid to parents and adolescent children of servicemen who died (were killed) as a result of a crime committed by them during the performance of military service.

6. Set forth Point 1 of Paragraph 5 of the 31 March 1992 Ukrainian Cabinet of Ministers Decree No 161 "On the Pay of Ukrainian Armed Forces Servicemen" using the following wording:

"To servicemen who have been released from compulsory active military service, a pay in the amount of two minimum salaries and, to the individuals listed from among children-orphan and children who have been left without the care of the parents—three minimum salaries."

7. The force of this decree extends to servicemen of the Border Troops and the Ukrainian National Guard, Civil Defense Troops, and of other military formations created by the Ukrainian Supreme Soviet and also servicemen who are performing military service in the ministries, departments, organizations, and institutions of Ukraine.

[Signed] K. Masik
First Vice Prime Minister of Ukraine

[Signed] V. Pekhota
Ukrainian Cabinet of Ministers Minister

Ukrainian Language Military Laws Provided To Sailors

*92UM1242A Kiev NARODNAYA ARMIYA in Russian
24 Jun 92 p 1*

[Article by Lieutenant-Colonel Vladimir Lartsev: "Will We Overcome the Information Blockade?"]

[Text] A ban on the transmission of Ukrainian television and radio coverage and on distribution of the Ukrainian

press in the Black Sea Fleet has been implemented based on Admiral I. Kasatonov's order and is one of the serious causes that is impeding the recruitment of sailors to our side.

"Sozidatel" [Creator], the Kiev Union for the Social Protection of Servicemen, Retirees and Their Family Members decided to make their modest contribution to overcoming the information blockade of Black Sea Fleet personnel. For 20,000 rubles they acquired 2,000 copies of collections of Ukrainian laws on military issues that have been published by the NARODNAYA ARMIYA newspaper editorial staff and have sent them to the Ukrainian Navy command authorities in Sevastopol for free distribution among fleet officers, warrant officers, petty officers and seamen.

The "Sozidatel" Union board of directors appeals to the leadership of the Union of Ukrainian Officers [SOU] to follow our example and thereby prove, not in words but in deeds, that SOU's goal is building the national armed forces.

BALTIC STATES

Statistics on Russian Troops Stationed in Lithuania

92UN1673D Vilnius LITHUANIAN WEEKLY
in English 12-18 Jun 92 p 1

[Unattributed Article: "Russian Troops in Figures"]

[Text] Russian military units are stationed on 68,000 hectares of Lithuanian territory, i.e. on 1.2 per cent of her area, Lithuanian officials report.

According to the military leadership of Russian North West Group, there were 34,582 servicemen and 1,436 students of higher military schools in Lithuania as of January 1, 1992. Among them: 7,302 officers, 3,619 warrant officers and 22,221 privates and sergeants.

On March 2 of this year, the Russian-declared official date for the beginning of army pull-out, 36 military vehicles carried 103 soldiers out of Lithuania. In March-April, only 253 servicemen left the Lithuanian soil. If the current withdrawal tempo prevails, the last Russian soldier will leave after 30 years.

At the end of May and the beginning of June, 1,500 new draftees have been brought to paratroopers' training units still stationed in Lithuania. Consequently, the initial military figures have not changed. There are large Russian garrisons in every big Lithuanian city.

The Lithuanian delegation has estimated that a damage amounting to \$146,147 billion has been inflicted on the Lithuanian state since 1940.

CAUCASIAN STATES

Creation Of Azerbaijani National Army Discussed

92US0556A Baku EDEBIYYAT GEZETI
in Azeri 1 May 92 pp 1-2

[Article by Huseyn Abbaszade: "Our National Army"]

[Text] An unnecessary fact for this discussion is that every independent state has its own national army. Now there is no country in the world, no matter whether it is large or small, which does not have its own armed forces. And then there is another truth that throughout history the militarily powerful country has always subordinated countries weak in defensive capability to itself, seized their lands, carried away their natural resources and impoverished their people.

As for our country's leaders, for a long time they did not wish to understand this truth. They made excuses and said that if we create our own army, then forces of the USSR Ministry of Defense would immediately withdraw from Azerbaijan, and we would remain alone with the Armenians. They are well armed. We would be unarmed and in serious condition. Our nation's leaders held a heated discussion on creating a national army in parliament. As for the armed Armenian brigands (essentially certain parts of the Armenian army), they penetrated Azerbaijan's territory, passed judgment on the peaceful population, destroyed and burned our towns and villages, and committed terrible atrocities.

I am sure that a reportage on one session of the republic Supreme Soviet is still in the minds of television viewers. In it, national representatives from the democratic bloc in our parliament demanded from the chairman of the Supreme Soviet who was conducting the meeting that he enter the question of establishing Azerbaijan's national army into the session's agenda. Deputies representing the communist bloc who were led by the president and slaves to his every whim, opposed this important question. This was a blow struck at the nation by its own "sons".

Whatever one believes, I cannot believe that the President, who opposed Azerbaijan's national army and who deferred to orders received from the Center at this session, understood what a great injury he had done to his own people on this dark day. Life has proved that all the woes which have fallen on our heads in recent years were the result of our republic leaders' obedience to the Central government for the sake of preserving their own interests and jobs.

In this session, which was a black page in the history of Azerbaijan's independence struggle, Bekhtiyar Vahabzade, a loyal son of our people, approached the microphone in an excited state; I remember well his sharp debate with those who opposed the establishment of an army (much of his speech remains on videotape). The fact that two military deputies—Lieutenant-General Valeh Bershady and Major-General Mustafa Nesirov—

opposed the creation of a national army was met among the people with justifiable dissatisfaction and protest. Even though common people might not understand it, the white-haired generals should have known that national armed forces were definitely necessary to go up against Armenia which had already created its own armed forces. At that time objective journalists from foreign countries had informed readers of the central press about the organized Armenian army that had been raised. In our republic instead of taking measures to counter this, we stuck our heads under a pillow and tried to believe that there was no need to be bothered, that the Soviet army, which stood tall as a mountain, would not leave us without help against the Armenians. And that there was no need to create our own army.

Shortly after seeing the reportage which had been presented on television about that session, I called up Bekhtiyar and expressed my gratitude for his courageous speech. I learned that many had called him before I did to express their agreement with him. Bekhtiyar had just returned from the session and, complaining from the heart, said: "Oh, brother, the fact that some good-for-nothing deputies are so indifferent to the fate of the people on this dark day burns me up. How someone can cheat himself and others is his own business, but in my world cheating the people is the greatest crime."

Three or four days had passed since the debate between the generals and the poet. I was sitting with Balash Azeroghlu in the Writers Union and we were reading an official document. General Akim Abasov, who had retired as deputy chairman of the republic Council for the Defense of Peace came in. I had known him for a long time. I introduced the guest to Balash. We informed the General about Anar [chairman of the Azerbaijan Writers Union]. Finding out that he was coming to the meeting, he looked indecisive.

"What do you want, Akim? Can I be of help to you?"

"No. I wanted to talk to Anar about Bekhtiyar Vahabzade."

Although I already knew the answer, I asked our guest: "Is it about the argument between Bekhtiyar and General Bershadly?"

Akim Abasov began to speak:

"If Anar does not take steps against Bekhtiyar Vahabzade about his actions, then we, a few war veterans, will issue a protest letter about the poet's conduct at parliament. This letter is already written."

Akim Abasov fell silent, and we said that we were in agreement with Bekhtiyar Vahabzade's speech. The fact that General Bershadly opposed the establishment of a national army had amazed us, to say the least. Most of the writers are of this opinion. I said to him that if the protest letter you mentioned is published in the press, its signatories will themselves do harm. The secretariat of the Writers Union would provide a sharp response to it

in the press. The old general, who did not expect that we would have such a negative reaction to this issue, fell silent again. "I will go and inform my comrades", he said. Then the three of us talked about the need for Azerbaijan to have its own national army under this tense wartime situation. In his conscience, General Akim Abasov understood our opinion.

In the high part of Karabakh the crimes of the underhanded Armenian brigands were exceeding the bounds, and death and bloodshed increased. The killers, receiving no opposition and remaining unpunished, grew more ambitious. The basic fault in all this was within ourselves.

Finally, at the strong demand of the Popular Front and national representatives from the democratic bloc, the president signed an order last November (although it was already too late) establishing a national army. This order inspired our brave sons—indefatigable defenders of the fatherland—who had been unarmed before a sly, well-supplied enemy for a long time. It created faith among the public. Some journalists, looking for an opportunity to serve the leadership, tentatively supported the president who had given the order to create the national army, and raised a commotion about it in the newspapers, radio and television. As for General Valeh Bershadly, he was appointed Minister of Defense.

And I was one of those who praised the establishment of the national army. I viewed with joy a photograph in KHALG GEZETI showing the military training of youth who had been called into the new army. I witnessed with a feeling of pride the soldiers of the national army, automatic rifles in their hands, swear an oath on the graves at the Boulevard of Martyrs of those who had been victims on the road to freedom, and watched them march off to the front. But all this was a dazzling facade. There was no army which defended the peace and honor of the people of Azerbaijan in this difficult situation, and no unified command was created. The national army existed only on paper. They had cheated the people of the republic. And not for the first time...

What goal were those who perpetrated this criminal game pursuing, to whom was it necessary? How correct was it to appoint General Valeh Bershadly, who had opposed the national army with such panache in the parliament?! There are many such complicated questions.

Those opposed to Azerbaijan's establishing its own national army are not only among us, they are also outside the republic. The strange thing is that these strange voices, inside and outside the republic, bore a striking resemblance to each other as if they had been united into an ensemble and were capably led by a single director.

Aviation Marshal Shaposhnikov, Commander in Chief of the Unified Armed Forces of the Commonwealth of Independent States, had stated his strong opposition to Azerbaijan's establishing its own national army in his

recent speeches and interviews. He often said that we can in no way permit this. How can one explain this? Is this not interference in the affairs of an independent state? The Marshal, on one hand loudly announcing that he will not permit Azerbaijan to create its own national army, on the other hand closes his eyes to the existence of an Armenian army which is armed to the teeth. And he provides every kind of help to Armenian armed forces which have begun a planned occupation of our republic. The participation of military units which had been passed to Russian control in criminal actions against the people of Azerbaijan together with Armenians is now known to the world public. The participation of the 366th motorized artillery division in the tragedy, the likes of which had never been seen, in Khojaly, is a fact that does not lie.

Other than this, those opposed to Azerbaijan, which is being exposed to hostile aggression, creating a national army for its own defense accepted a decree on establishing a million and a half strong army in Russia. Finally, Russia has enough military units under its authority. At a time when it is going through severe economic difficulties, why does it need a defense ministry? Without it, the CIS Unified Armed Forces General Command is still subordinate to Russia. In my opinion, this measure conveys a purely propagandistic character.

The Russian leadership and General Command of the CIS Armed Forces, along with impeding by every means Azerbaijan's creating its own national army, is taking care to supply the Armenian occupying army with highly specialized cadres. Bases training cadres for this army are in a number of places in the Transcaucasus. Official information on this has been issued by the Azerbaijan Ministry of Defense.

At the end of last year in an article on the Armenian-Azerbaijani conflict in *KOMSOMOLSKAYA PRAVDA* it was noted that all the soldiers on the naval infantry roster in a unit of the Black Sea Fleet were Armenian youths who had been drafted into the army from Nagorno-Karabakh. The question is why is it that way and who authorized it? Is it purely by chance, or are marines being trained for an Armenian army which has become rabid from its own depraved actions in the mountainous part of Karabakh. I wanted to add this to what I said above: the Commander of the Fleet of the CIS (the former USSR) is Fleet Admiral Vladimir Chernyavin, who until recently was a USSR Peoples Deputy from Lenkeran. And he was informed about the tragedy the Armenian army has committed in Nagorno-Karabakh. Even in meetings with his electorate he had promised that he would help the people of Azerbaijan in this matter. Is this Fleet Admiral V. Chernyavin's help to us?!

Now, at a time when Azerbaijan is marching along the road to complete independence again, Azerbaijan's sole hope, in distinction to other sectors, in the work of

establishing a national army for its own defense is itself. It must nourish the hope for honorable and talented youths.

It is clear that there is a great need for military cadres—experienced soldiers, junior commanders, officers—with various skills for a newly created national army taking its first steps forward. An organized army is a massive and complex organism. To build it up and run it is a complex job. Under any circumstances this mechanism must always have high fighting capability and readiness. Otherwise, what is the sense of maintaining armed forces? One of the important problems before the command of the Azerbaijani army is to open secondary and higher military schools for the training of professional commanders.

Fate has given Azerbaijan such a neighbor that it must be always vigilant and not be taken in by sweet promises. It is necessary to maintain a strong, organized army in order to repel the Armenian nationalists who dream of tearing off chunks of their neighbors' lands (Azerbaijan, Turkey, Georgia) and let them know their limits, and revive the forgotten traditions of our ancestors.

One of the sacred wishes in my life was that I would see our Azerbaijan have its own national army. Now, thank God, I did not die and it is my fate to see this joyous day. I also wished to see our tricolored flag fly over the close ranks of our national army.

I say with some satisfaction that when I heard recently that our army fought with courage against the bloody enemy on all fronts that my heart beat more rapidly. I believe in our army's brilliant victory in the campaign for justice and freedom. And I live with the belief that it will also be granted me by fate to see that happy day.

CENTRAL ASIAN STATES

Process of Forming Kazakh Armed Forces

92UM1208A Moscow KRASNAYA ZVEZDA in Russian 2 Jul 92 First edition p 2

[Article by KRASNAYA ZVEZDA correspondent Colonel A. Ladin in the column "National Armies: A View Inside": "In a 'Shanyrak' Tent: Outlining Kazakhstan's Armed Forces"]

[Text] Six weeks have passed since Nursultan Nazarbayev signed the decree creating the Armed Forces of the Republic of Kazakhstan. The 40th Separate Combined-Arms Army, the same one which saw action in Afghanistan, no longer is part of the Turkestan Military District, which is nearing its final days. The army is now part of the CIS OVS [Combined Armed Forces] as a component of the Armed Forces of Kazakhstan. There however are more changes than that. What events are presently in the making?

I intended to have my question answered firsthand. So I set out to visit Lieutenant-General Anatoliy Ryabtsev,

commander of the 40th Army, who is at the same time First Deputy Minister of the Republic. Incidentally, the General has been serving in this geographic area since 1989. His post until then was Yerevan, where he served as Deputy Commander of the 7th Army.

"There is no doubt about it; the creation of the Armed Forces is not something that can be accomplished all of a sudden. It is a long and difficult process," said Anatoliy Ryabtsev. "They are being formed along with organization of the National Army. This matter for the leaders is new, one that requires knowledge drawn from many fields. I can see how difficult this is for Kazakhstan's first military minister, Colonel-General Sagadat Nurmagambetov. In addition to being actively involved in military force generation in the Republic, he must maintain constant contact with his CIS OVS partners, and participate in writing and implementing the various agreements made with the Commonwealth countries."

From our notes: Kazakhstan in creating its own Army is attempting to build its defense on the basis of collective security. The Republic signed the Collective Security Agreement in Tashkent on 15 May, while on 25 May it signed with Russia the Treaty on Friendship, Cooperation, and Mutual Assistance. Moscow took on the obligation of assisting Alma Ata in the creation of its Armed Forces.

Having acquired its independence, Kazakhstan has no intention of cutting itself off and becoming isolated. The independent state's defense is being built on principles guiding the domestic and foreign policies of President Nursultan Nazarbayev. The principle task facing the Armed Forces is defense of the Republic's territorial integrity.

Yes, the President was quite explicit in position relative to defense matters. "Kazakhstan, the same as any other sovereign state," he stressed in his recently published work, 'The Strategy of Formation and Development of Kazakhstan as a Sovereign State,' considers the maintenance of its defensive capability to be one of the most important functions and a matter for all of its people, and, until an all-encompassing system of international security is created, will continue to pursue military construction in concert with other states intending to join us in constituting a defensive union." Lieutenant-General Ryabtsev explained that the authorities of the 40th Army do not intend to stand by idly as mere observers of events associated with the formation of the Republic's Armed Forces. A considerable military force has come under the jurisdiction of Kazakhstan. The presence of new models of weapons and combat materiel in every regiment provides a basis for according the force a fairly high evaluation and for speaking confidently of its capability to exhibit mobility and sufficient effectiveness.

From our notes: Of 104 deployed heavy missiles and their launchers, 70 [figure illegible] percent must be eliminated

in accordance with the CIS treaty and previously developed plans. Since the warranty period of these ICBMs will expire in the next two to three years, plans call for removing them from service and destroying them.]

Army authorities intend to proceed as early as this year, with the support and assistance of the Republic's Ministry of Defense, to improve the combat readiness of the large strategic formation as the most significant operational echelon of Kazakhstan's Armed Forces. What does this entail?

First, setting up command and control for military structures which will be incorporated into the 40th Army following the division of the Turkestan Military District and passing of a number of units from central control to the jurisdiction of Kazakhstan. Second, resolving problems associated with logistics. Third, strengthening and refining cooperation between Army units, the Air Force, and subunits of the PVO [Air Defense].

Extremely pressing is the problem of troop clothing. The Army is presently in a position to clothe the incoming spring conscripts. But what to do at a later time? There are no such stocks for the year 1993. The requirement is considerable: 45,000 sets of uniforms. The traditional deliveries from Russia, Ukraine, and Byelarus ceased this year. Even more problematic is the officer uniform situation. All persons in the Army would like to see the partnership ties reestablished; they hope to see effectuation of new intergovernmental agreements. A system of symbolic emblems has not yet been devised. It most likely will include elements of the new republic emblem: the "shanyrak" tent and the legendary "tulpar" winged horse.

I let the First Deputy Minister know of my interest in the "newness factor" relative to existing combat materiel. What if the immediate future sees a need to equip the Army with new weapons? Lieutenant General Ryabtsev told me his reasoning on this subject. A strong army cannot do without modern weapons. Nevertheless, one must take into account the economic realities standing before Kazakhstan, which only relatively recently acquired its independence. Keeping this in mind, it hardly pays to become for two years or so involved in replacing weapons and equipment of some superior designs. All the more since the tanks, BMPs, artillery, and other systems in Army service are of the latest generation. In addition, there are sufficient quantities of equipment formerly belonging to the group of forces.

From our notes: In accordance with the presidential Decree on the Creation of the Armed Forces of the Republic of Kazakhstan, all military units and large units, installations, depots, real and movable properties of the CIS OVS located on republic soil were transferred to the jurisdiction of the republic and made a part of the Armed Forces of Kazakhstan.

Nonetheless, on the agenda of modernization of Kazakhstan's Armed Forces is a search for sources of necessary combat materiel. It appears that the program is to

favor precision weapon acquisition and rapid mobility of the combat arms. However, this constitutes a task for the future. Kazakhstan's military is more concerned today with equipment that is in need of scheduled maintenance. As many as 1,000 items of equipment are normally dispatched annually to repair enterprises. However, not a single combat vehicle, not one artillery system, has been sent off to repair in the last six months. The fault lies with the nonexistence of repair contracts and the lack of repair funds. The republic is experiencing a difficult situation relative to repair enterprises qualified to repair weapons and military equipment. The sole exception is a plant that specializes in servicing armored personnel carriers and self-propelled equipment of a definite version. This is another case where it is necessary to effect agreements with Russia, Ukraine, and Byelarus.

Another problem is maintaining the strength of the Armed Forces in line with the requirements of defense sufficiency. I was told in the Ministry of Defense that the Army is even now undergoing reduction, that in two to three years the strength will amount to about 170,000 men. There will also be a reduction in the combat arms. I asked the question of whether there will arise a need to create additional command and control echelons in various areas, since the republic's size is so vast. The answer I received was that this would not be required in peacetime. Located previously on the territory of Kazakhstan was the Central Asian Military District. Remaining there are well-equipped command and control facilities and lines of communication. They assure reliable leadership for troops from more than one center.

However, the Ministry of Defense has sufficient work to do without the above. At work in the ministry are three commissions occupied with developing a concept of Armed Forces construction and a military doctrine. Under way is a call-up, and this means supervision and more supervision. Coming up is the summer training period, which brings on more concerns. The ministry's leadership intends for Kazakhstan's Armed Forces to become—in the shortest period of time and in deed not word—a powerful fighting component of the CIS OVS. To be taken on is the formidable task of setting up a well-structured system for combat training, and personnel education of a moral, psychological, and patriotic nature.

The abovementioned problems are being resolved successfully, even with the ongoing migration of commissioned, enlisted, and noncommissioned officer personnel. This is attributable to the fact that the military are not discriminated against whatsoever in Kazakhstan. Anyone wishing to serve in the republic's Armed Forces is free to do so, with no requirement for taking an oath of allegiance. By the same token, no pressure is applied to anyone expressing a desire to relocate to another duty station, to his native land. It is true—and the Ministry of Defense makes no secret of this—that some good specialists are being lost. The Army will be experiencing a cadre shortage for some time to come.

It should be mentioned here that some thinking is being done relative to training of military specialists. There is a possibility that new military schools and academies will be opened. The agreement made with Russia to train military cadre in its schools must suffice for the present. Under review is a program for selecting candidates for admittance to military schools and academies; there should be an increase in number of officers and warrant officers of Kazakh origin. Three percent of the officers currently serving in the 40th Army are of native origin. The ministry is proceeding on the assumption that no difficulties should be encountered in recruiting the necessary number of men who wish to devote their lives to serving in the republic's Army. Expectations are that there will be a rise in prestige of the service. Kazakhstan even now is striving to provide the Armed Forces with all its necessities. There will be improvement in conditions under which officers will be serving. There are loose ends that must be tied: There is a housing shortage and delays in disbursement of pay due to a shortage of cash, but these, it is believed here, are troubles of a temporary nature.

The formation of the Ministry of Defense has made it possible to resolve many problems simply and more quickly. Managerial skills are improving, and the ministry is establishing the essential working ties both within the republic and beyond its borders. Although not everything is amenable to rapid solution, it appears that the day is not far off when service in the Armed Forces will be both honorable and advantageous. I believe that there will be both contract service and an alternative version, in addition to the universal service arrangement.

It would be impossible to discuss here all the plans and problems. One of these ideas concerns involving the troops in working along with villagers to bring in the harvest. The people help the Army, so why not help the people in return?

Uzbek Defense Ministry Takes Over Newspaper 'Frunzevets'

*92UM1217A Moscow KRASNAYA ZVEZDA in Russian
7 Jul 92 First edition p 4*

[Announcement by Cadet B. Astafyev; "'Vatanparvar'—'Defender of the Fatherland'"]

[Text] Recently one of the oldest newspapers of the Armed Forces of the former USSR, FRUNZEVETS, changed its name. It became the central organ of the Ministry of Defense of the Republic of Uzbekistan and is now called VATANPARVAR, which is translated as "Defender of the Fatherland."

The creative team of the newspaper VANTANPARVAR, headed by Yu. Popov, intends to continue the good traditions and maintain its reputation as one of the most widely read newspapers in the republic. It will be published in two languages: Uzbek and Russian.

Language Training for Uzbek Army Commanders Started

92UM1233A Moscow KRASNAYA ZVEZDA in Russian
9 Jul 92 First edition p 3

[Item from Tashkent by Lieutenant-Colonel V. Astafyev: "In the Uzbek Army Commanders Have Begun Studying the State Language, and Enlisted Men Have Begun Studying Russian"]

[Text] The summer period has begun in an organized manner in the Army of Uzbekistan. Training differs little from past years, but there is one feature. In the first hour of a three-hour class in social-humanities training officers and warrant officers who have a poor knowledge of the state language have been mastering Uzbek so as to have better contact with subordinates, and first-term soldiers of the native nationality have been improving their knowledge of Russian in order to better understand their commanders.

Such classes now will be conducted constantly for the entire period of the Uzbek Army's transition to the state language, which according to specialists' forecasts will take five-six years. For now, over 70 percent of command positions are held by Russian-speaking commanders.

MOLDOVA

Reports, Interviews From Visit to 14th Army

92UM1197A Moscow KRASNAYA ZVEZDA in Russian
26 Jun 92 First edition p 2

[Report by Lt-Col S. Popov, KRASNAYA ZVEZDA correspondent: "The 14th: Strokes in the Portrait of an Army Which Finds Itself at the Center of Dramatic Events"]

[Text] Do not be surprised at the unusual wording "Strokes in the Portrait of an Army." I could have written another "political commentary" about the situation in which the Russian 14th Army finds itself in the Dniester region. To be honest, those were my intentions when I set out on the temporary duty assignment. I understood when I arrived, however, that this was neither the time nor the situation for methodically arranging opinions, assessments and conclusions, reinforcing it all with deliberate and impartial analysis. May the reader forgive me for a certain "dishevelment" and fragmentation of the text, but it seems to me that the most important thing today is to hear the voices, see the faces and feel the pain which the 14th Army, totally sapped by the political circus and having suffered considerable noncombat losses (and now, combat losses as well), but still strong, still loyal to its duty, has borne for the past several months....

The headquarters of the 14th Army immediately reminds one of the word "war." It was in films on war that I have seen sandbags like those blocking the windows of the KPP [main gate] and those on the floors of

the 14th Guards Army headquarters. Whom are they barricaded against? "Against everyone," answered the duty officer at the KPP, without going into detail. In general, the answer was correct. There have been thefts of military motor vehicles and even combat equipment. At the REB [maintenance and service base] at Parkany people broke into a depot and stole dozens of firearms. Who did this? Just try to find out. In the city there are hundreds of people in camouflage suits: guardsmen, Cossacks, members of militia, members of territorial rescue detachments. There are also just plain criminals. And there are terrorists infiltrated by the opposing sides. Just who...? Since that is not clear, then all-round defense is necessary. Against everyone.

The 14th has been on almost confined-to-barracks status for a long time. At headquarters itself 30% of the administrative officers go on daily duty armed with semiautomatic rifles. At night army special-purpose forces fire blanks wildly as they "practice repelling a possible attack on headquarters"....

Col Aleksandr Mikhaylovich Baranov, deputy army commander for personnel, now has yet another duty. He maintains communication with the mass media—more precisely, he is constantly attacked by the "media." He only has to go to Moscow for a couple of days, and Radio Liberty immediately gets into it. Everyone wants to know what is occurring around the 14th, "whom" the army supports, whether it is fighting on the side of the Dniester region, as Moldova maintains, and what is it up to in general. What can Baranov say? The army is not fighting but protecting itself and its people. Its situation even following its transfer to Russia's authority remains uncertain. There are guidelines and words from the politicians, to be sure. Protect the Russian people but do not become drawn into a conflict. If you are fired upon, fire back—but, once again, do not be drawn into.... Just try to combine all of this. The personnel have to be restrained from impulsive actions. And with respect to the 14th Army's withdrawal, the colonel is very concise: "The most we can take are the banner and the stamp. The city is literally taking the railroad tracks apart." One can boldly add: Up to 80% of the officers and warrant officers will stay with the city.

There is a call from Dubossary. The deputy commander informs Col Baranov that he cannot deliver the personnel for scheduled assemblies. If he does, he will be unable to post security. And security is a must. A grenade sailed into the unit's motor pool the previous evening, and it was just luck that there were no casualties. There is shooting every day....

Neither Baranov nor the other man on the phone could have known then that things would flare up in Bendery in a few days, that there would be dozens of grenades and hundreds of casualties. Assemblies would be out of the question.

It is drawing a very long bow to call the 14th an army in the operational-tactical sense of the term today. After

"the process became irreversible" on the right bank of the Dniester, its units left for Moldova with their equipment and weapons. And although they are still listed as an army, there is not even communication with them. So the only thing the 14th can count on at this level are those 150 officers who have not yet taken the oath to Moldova and are waiting for their fate to be decided.

The 14th is still called an army, however. Its main strength is the 59th Division. The division is commanded by Maj Gen Vladimir Mikhaylovich Kozhevnikov. This is what he had to say.

"I do not give interviews. When I am asked for an interview, I say: 'Tell me, where is Gen Uskhopchik today?' Where is Uskhopchik, who was shown on television and was written about? I have seen something of life. I was at Spitak and at the Zvartnots airfield—and not as a tourist, you know. Everything was clear there, however: who was against whom, who was for what, what one had to do. But here.... When there began to be casualties in Bendery, the division was simply blockaded. And it all began. Deputies would start to arrive in the early morning, followed by Guardsmen, followed by women and then veterans. They all wanted to know one thing: 'Whose side are you on? You live on our land. You have links to it. So protect it.... You can see that women and children are taking to the trenches. What about you?' It was during that time that our tanks appeared in the Dubossary area. But you probably know about that: how women 'turned them back'....

"I have heard a lot of different things about myself both here in this office and over there on the square, where pickets stood for days—and the 'traitor' was not the most powerful. Once they even told me to my face: 'We know, general, that you will be the first to run away. You do not even have your family here. I picked up the telephone, called my wife and told her we were coming over, that in 15 minutes we would be on our way there for a visit. 'We were only joking,' they said. What can I tell the deputies, the veterans and the women? A Russian flag hung on the wall behind me. I pointed to it and said that the army exists and functions according to orders.

"General Makashov came. He issued the cry: Everyone to the positions in Dubossary! The impression was that he is a patriot, and we are not. But these are totally different things: to call for someone to do something when you actually answer only for yourself, and to do so when you are responsible for hundreds of people, for hundreds of families. What did he do when he was district commander? Did he give the call?

"The officers are at the end of their rope. Do you think that it is an easy thing to see women on their knees before you? Some are departing for the national armies, some are just calling it quits, and some are staying here. I was recently visited by a warrant officer, a repairman with a golden touch, an 'Afghaner.' He joined the Guards. His fellow 'Afghaners' and friends are there, and it is clear

who is for whom. I cannot guarantee that under certain circumstances many people will not do the same."

Another officer and I were stopped on a street in Tiraspol by an elderly man. He gave his name as Maksim Frolovich Rubanov and said that he had been an artilleryman during the war. "Like demons, fellows, you have to fight like demons. I say that as an old soldier. Break through, encircle and.... Then everything will be all right. You tell whoever should know there, fellows, tell them you have to fight like demons...."

Relations between the army and the city are complicated and, most important, very unpredictable. They involve hope and misunderstanding, unforgettingness (the fact that weapons are shelling the Dniester area from the right bank of the Dniester, weapons left there by the 14th, for example, as though it left them there of its own free will), warmth and fridity. Maj Valeriy Vorokhov told me how, when the commander of the 14th sent an armored personnel carrier to guard a school in Bendery, he was practically worshiped not only by the residents of Bendery but by the entire surrounding area. But when the armored personnel carrier left 2 days later.... I would not like for anyone to hear the things said about the major.

I had a very candid discussion with an officer of the 14th, who asked that his name not be used. "I'm fed up with that entire policy. One lives here and does not know what will become of oneself and one's family tomorrow. What kind of military service is that—constantly to be waiting for something (for what, no one knows)? Where is the neutrality? The politicians have once again 'laid the army open.' Some of them lie, others cannot make a decision. Russia would just have to shrug, after all, and the shelling from the right bank would die down. Do you know what happened when tanks from the division showed up in Dubossary? Four hundred of the opponents scattered. They say that some of them are still being sought. They have been declared deserters...."

How is one to serve when one does not know what will become of him tomorrow? The father of Capt F. is a Russian, his mother is a Moldovan, his wife a Ukrainian. He only speaks Russian. He knows no other languages. His family is there on the right bank. None of his neighbors there knows where and whom he serves. And God forbid they should find out. Anything can happen today. He gets home once a week, twice at most. The captain carries a general passport in his pocket, which states that he is Moldovan. Why? The opponents in Moldova might not like one's looks.... Show me the court which would undertake to try this captain....

Then take Lt Col D. It is not enough that his family and his apartment are over there, practically in enemy territory. His daughter is seeing a young fellow. Things are moving toward a wedding. Then the young man receives his notice to report to Moldova's army. Are the son-in-law and the father-in-law going to shoot at one another, leaving the girl either fatherless or a widow?

What about the officers and warrant officers who have waited so long for apartments, and now, when they already have the authorizations in hand and several apartment buildings are almost finished, all of a sudden to be told that they might have to leave? And where are they to take the wives and children of the officers and warrant officers if the worse suddenly happens (it is a decent drive of only about 15 minutes from Bendery to Tiraspol for a combat infantry vehicle), when there are no relatives and no haven of their own?

The KPP of a combat engineer battalion at Parkany is guarded by a somewhat unusual detail made up of soldiers and... young civilian men with semiautomatic rifles over their shoulders. Civilians, because the battalion was placed under the authority of the Moldovan-Dniester Republic and for now—in order to avoid excesses, let us say—and until its status is “settled,” the Parkany rural soviet details a guard of 15 young men for the unit. While I was waiting for the battalion commander to be told of my arrival, a “soldier,” just a boy, asked me for a cigarette.

The battalion commander is Igor Vladimirovich Dudkevich. His deputy is Maj Valeriy Vorokhov. We talked. The officers—incidentally, both “Afghaners”—would each add to what the other had said and we had something like a monolog/duet.

“When we announced that we were being transferred to the command of the PMR [Moldovan-Dniester Republic], we were called traitors and betrayers at 14th Army headquarters. We feel that this, the Dniester area, is our homeland. We have no other, and we shall defend it. We were called traitors, but today, we have been told, there is no battalion like it in the Russian army. They have been disbanded.

“And how did the residents take the change? The army immediately ‘shut off all the faucets’: food, fuels and lubricants, and so forth. When they learned of this, the Parkany residents brought the soldiers baskets of bread, fruit.... We needed a pipe to replace one in the boiler room and we went to an enterprise for it. As soon as they learned that we were from Parkany, they received us out of turn and told us they would deliver the pipe.”

I later enquired about that battalion at the headquarters of the 14th. The mildest and most diplomatic assessment was this: “They turned out to have weak nerves.”

No matter how you look at it, you cannot avoid the fact that the 115th violated the oath and refused to carry out orders from superior commanders and chiefs. For an army it is the most terrible of dramas when its individual units and subunits begin operating on their own.... This fact is further proof of the extremes to which things have gone. It should alert everyone. Will the case of the 115th combat engineer battalion become a scenario which could happen with the entire 14th if events develop unfavorably and the situation in the Dniester region is further inflamed?

During the 10 days since my return from the Dniester region some harsh and terrible changes have taken place there and probably in the army itself. Now, as I read the summaries of combat operations from the Dniester region or watch television, my greatest fear is that I will hear a familiar name and the word “wounded” or “killed.” I frequently recall that young soldier from the combat engineer battalion at Parkany who asked me for a cigarette.

INCIDENTALLY:

The date of 22 July, which is closely linked in our minds with the tragic day the Great Patriotic War began, is doubly painful for many residents of Murmansk, especially the elderly, the veterans. On 22 July, the Murmansk television company Murman reported an act of vandalism during its program TV Inform: Novosti. On the 79-kilometer Murmansk-Pechenga road unknown people had degraded the fraternal grave of fightingmen of the 14th Army who died defending the Polar Region during the Great Patriotic War.

Viktor Kriklenko, leader of a search group, reported this to the procurator’s office of Kolskiy Rayon. It was through his efforts over a 4-year period that the monument was erected. The hooligans smashed slabs with the names of the soldiers buried in the fraternal grave—and there were more than 100—broke open the three-tiered brick structure beneath which the soldiers were buried and scattered the fragments.

An investigation is underway.

Profile of Dniester Region Commandant Bergman
92UM1215A Moscow KRASNAYA ZVEZDA in Russian
7 Jul 92 First edition pp 1,2

[Article by Colonel V. Zhitarenko, KRASNAYA ZVEZDA special correspondent: “Curfew”]

[Text] A curfew has been in effect in Tiraspol for several days now.

“Drop your weapons”!

The three looked in astonishment at the UAZ’s which had borne down upon them in an instant, brakes shrieking, and already formed a semicircle of soldiers from the commandant’s office, and at the colonel scrutinizing the detainees with a flashlight.

“Just who are you?” the only one not to lose his head asked, and even tried to grasp the handgrip of his machine gun more firmly. No order was given, but the breech mechanisms of a dozen automatic rifles clicked in unison, and it seemed that the weapons literally flew from the three to the pavement on their own.

“I am Colonel Bergman, commandant of the Dniester region. Your passes? Why are you in Tiraspol”?

"We are here to guard the school. Our battalion has been guarding it for a long time."

They were lying. As of the evening before all the guards in the city were being posted by the commandant's office. Just why were they lying? And what were they doing, armed, in the city at night? This would have to be cleared up. Had they simply left their combat posts for "a break and a good time" or was it something more serious?

Tiraspol is a city at the front, one might say. And not just because it is taking shelling from Bendery and Kitskany. Bursts of gunfire sometimes resound right there, in its streets. Marauders have announced their presence. There are only individual snipers, but they have instilled fear. Even the Tiraspol hospital was shelled. No damage was done, to be sure. Just try to find the scoundrel, though, when there are hundreds of people on the street in uniforms and parts of uniforms (they can even be seen in shorts), but bristling with weapons. They are all trying to give the impression that they have come straight out of combat. Some of them have papers. Some do not. But then, who is going to check? And especially, who is going to identify a deserter? Some of the residents have even caught scouts. They dragged one from the roof of a building, for example, where he was signaling with flares to Moldovan aircraft targeting the oil storage facility at Blizhniy Khutor. It is not the best thing to depend upon volunteers, however.

Colonel M. Bergman knew what he was getting into when he assumed the new post. He had been the military commandant at the Tiraspol garrison. Now he was commandant for the entire Dniester region. The President of the PMR [Dniester-Moldovan Republic] signed the order upon finally receiving the consent of the 14th Army: "We need to instill order among all those with weapons"! In order to establish that order, all of the formations are now under Bergman's command, including the militia and the Dniester Special-Purpose Battalion.

"Will that not be taken as army interference in local affairs?" I asked Mikhail Mikhaylovich. He shrugged his shoulders, indicating that it did not matter how some people would take it. The important thing was to permit people to live peacefully. I recalled a Bergman joke quoted by one of the warrant officers at the garrison: "Yes, the Moldovan-Jewish commandant's office is conducting a Russian expedition."

The Colonel was born here, educated here, and has served here since he was a Lieutenant. He seems to know everyone in Tiraspol. Seven generations of Bergmans rest in the local cemetery. His grandfather died in a Romanian concentration camp. His father escaped at the age of 17. His father's brother lost his wife and two sons in the Romanian occupation.

The Colonel is a Master of Sport in self-defense. This is not why athletes are chosen for the commandant's office, however. They simply need coolheaded and audacious

men. It is the nature of the service. Anything can happen. And it so happens that mostly Moldovans serve there. It is a good thing, though, that each of them is well acquainted with the city and knows the ethics and ways not just of the groups making up its population but in some cases even those of individual families.

It is the sixth day of the war in the Dniester region and the second since Bergman assumed his new post. We drove around the deserted streets of Tiraspol. So the curfew was being observed. Personnel manning posts set up at crossroads stopped even the commandant's vehicle with great caution. If you know the situation and watch carefully, you might see the barrel of a semiautomatic rifle or a machine gun, even a grenade launcher pointed at you from behind trees or bushes. It is not advisable to make abrupt movements. One has to understand the situation. The day before there had been cross-fire near these posts. A grenade was even tossed out from some crazy betezet [translation unknown].

As we approached the center of the city, two Rafiks rolled up even there, and twenty or so armed men emerged. "Why did you hold up our KamAZ?" they asked. "It is carrying ammunition. They need it desperately at the Kitskany staging area"! The commandant's people did not undertake to verify this and easily mollified the visitors. The KamAZ would be detained later, with a drunk driver, and it was necessary to telephone the position and ask for another driver. The ammunition had to be delivered.

Run-ins (thankfully, mainly verbal) between Cossacks and guardsmen and the commandant's service are an ordinary occurrence these days. Complaints even more so: "We are out there, on the front line, with the mines, and here you are, telling us 'Hands up!'!" One has to hear them out and persuade them. Even as Bergman was briefing the soldiers going on duty, one of them spat out the comment that this was not his business. The soldier was immediately relieved of his position by the chief of the MVD directorate for the Dniester region, who happened to be present. A soldier would prefer a bullet.

Near the hospital they apprehended some unknown person with a gas-operated gun and carrying some kind of papers from a cooperative. He was released, but without the gun. Three trucks without papers but hauling grain to a baked-goods combine were permitted to go on their way. But why had the head of the combine not provided them with passes? That would be looked into another day. Another vehicle from a guards formation came up. Not only the driver was drunk, but the vehicle commander as well. In the cab was a can of sour cream—some people live the good life even in a war. The commandant's office would have to look into it.

One of three radios in the commandant's vehicle, which was tuned to the militia frequency, suddenly came alive with the rapid-fire chatter. A suspicious individual had been stopped and asked for his papers. He had waved a grenade and disappeared into a courtyard. He was a tall,

thin man with black hair and dressed in a faded field uniform. Bergman tersely sent the message over the air: "Attention! Everyone to this sector." Another minute of furious travel?... Now there were six other patrol vehicles. The area was cordoned off. We soon spotted the tall, thin man in the faded uniform. Sr WO Aleksandr Tolgarenko yelled at him, ordered him to halt and fired a quick round. We ran up. I saw his angry face. The stranger's hands were over his head, but he was stealthily taking them down. The right hand grasped a grenade; the left the extracted pin.

I simply did not notice two men, Bergman himself and Sr WO Aleksandr Perederiy, immediately fall upon the right hand. A different reaction. The man, certainly not slighted when it came to strength, tried to free his right hand. Had he decided to blow himself up too? Bergman gave the order for the vehicles and the backup patrol members to pull back around 200 meters. Loudly mentioning the fact that "someone is just in the way," the vehicle commander very roughly shoved me behind a tree trunk.

"Negotiations" went on for 20 minutes or so as they tried to persuade Slava, the name he gave, to re-insert the pin into the grenade. They led him to a streetlight and left him alone under the barrels of semiautomatic rifles. He pretended to insert the pin, and then jumped over a fence.

"It's a good thing he moved away from the residence. There will be fewer casualties. That makes it easier," Bergman said with a sigh of relief.

By that time a special subunit had arrived at the scene in a BRDM [combat reconnaissance vehicle]. A sniper fired, the grenade exploded....

Marshal law is in effect in the city. The deaths of those like Slava are described simply as "neutralized."

Upon returning to Moscow I learned that a UN mission visiting Bendery had refused to go to Tiraspol because the Dniester people had recommended that it travel by armored personnel carriers. I thought to myself: Is there trouble in Tiraspol again? Has the commandant's service not been able to help?

I phoned the Dniester region. Nothing had changed, it seemed. Bendery was where things were hot, but the Moldovan side had brought in the mission by the Kaus-hany route, which was not being shelled. The mission did not even look at the center of Bendery, scorched by combat. It was suggested that Major-General A. Lebed, commander of the 14th Army, and G. Marukatse, chairman of the Supreme Council of the Dniester Republic come to police headquarters in order at least to give an account of everything. But is it not better to see things with one's own eyes? The combat equipment abandoned by the Moldovan side, the looted stores, the enterprises scorched by fires and the damage done to garrisons of the 14th Army? Strictly speaking, it would not have been overdoing things to provide a "back-up" of armored personnel carriers for an inspection, particularly in Bendery. Especially since the Moldovan side was shelling the city with mortars at that time. If the mission members had insisted on going without armor, however, who would have stopped them?

This is not a reproach to the UN representatives for failing to take a risk for the truth, however. They no doubt include some brave people. Ultimately, their mission was to facilitate a cease-fire, and this was hardly possible while sitting and waiting for the firing to cease on its own.

The trip took place three days later. As though to confirm the fact that the 14th Army was indeed guaranteeing safety.

An American journalist was wounded. I am told that this is the third or fourth casualty among my colleagues. War is war....

DEFENSE INDUSTRY

Kuybyshev Military-Engineer Academy Offers Boring Equipment

92UM1206C Moscow *TEKNIKA I VOORUZHENIYE* in Russian No 3-4, 92 p C3

[Military-Engineering Academy imeni V.V. Kuybyshev Advertisement: "Military-Engineering Academy imeni V.V. Kuybyshev"]

[Text] Military-Engineering Academy imeni V.V. Kuybyshev offers thermo-drilling equipment for boring bore holes in ice, frozen ground and hard rock while conducting engineering work.

The equipment functions off a truck and special vehicle engine exhaust gas discharge system. Experience has shown that the time for drilling bore holes in frozen and thawing ground while using the equipment is reduced by a factor of 1.5-2 in contrast to the mechanical boring technique.

Technical Specifications

Name of parameters	Thermodrilling instrument	
	Diesel	Gasoline
Technique of impacting the environment being destroyed	Thermal	
Weight, in kilograms	12	10
Bore hole diameter, in millimeters	100-110	80-90
Drilling depth, in meters	1.4	1.4
Drilling speed, in meters per hour:		
—uniform frozen ground	12-20	10-15
—rocky frozen ground	2.5-6	2-4
—rock	5-6.5	4-6

Address for inquiries: 11 Pokrovskiy Boulevard, Moscow, 109028.

COPYRIGHT: "Tekhnika i vooruzheniye", 1992

Scientific-Engineering Center Offers Consulting Services

92UM1206B Moscow *TEKNIKA I VOORUZHENIYE* in Russian No 3-4, 92 p 44

['Meandr' Scientific-Engineering Center Advertisement: "Information—Advertising—Technical Services of 'Meandr' Scientific-Engineering Center'"]

[Text] 'Meandr' Scientific-Engineering Center offers organizations and private individuals the solution to scientific-technical problems in the following areas:

- seismometry and seismology;
- ecology;
- general aerodynamics;
- mechanics of liquids and gases;
- mechanics of a deformed solid body;

—research of natural processes and phenomena;

—new processing technologies using the energy of explosions; and,

—exploitation of oil and gas deposits.

At your request, "Meandr" Center is ready to provide complete information about its processes and capabilities in the areas indicated.

The high quality and effectiveness of processes is guaranteed. Address: Post Office Box 16, 1- Bolshevo, Moscow Oblast, 141090. Telephones: (095) 515-54-12, 515-88-57, 515-78-95, 311-82-24. Fax/Modem (095) 515-95-59.

COPYRIGHT: "Tekhnika i vooruzheniye", 1992

NPO 'Uran' Offers Underwater Towed Sensor for Sale

92UM1206A Moscow *TEKNIKA I VOORUZHENIYE* in Russian No 3-4, 92 p 45

[NPO 'Uran' Advertisement: "NPO 'Uran'"]

[Text] NPO [Scientific Production Association] "Uran", jointly with The Physical-Technical Institute imeni A.F. Ioffe and "Fizintekh" MGP [translation unknown], are offering a towed unmanned underwater device for research of the water environment (NPA-EKO), that has been created within the framework of conversion based on our own original research.

NPA-EKO is designed to collect information that is needed to look for deposits of oil, gases, and other useful minerals, including metals, on the bottom of seas and oceans. It may be used for hydroacoustical and television photography of the sea bottom, to search for and study underwater objects, to detect anomalies of the Earth's magnetic field, and to measure background radiation.

It is distinguished from existing underwater devices by its capability to conduct uninterrupted searches for assigned ingredients of the water environment while being towed. It has a physical-chemical changes module that provides quantitative and qualitative analysis of components. The research program can be changed in the automatic mode which has not been achieved in any of the existing unmanned underwater devices. A similar module was used as part of an astrophysical device on space stations.

The commercial proposal of NPO "Uran", The Physical-Technical Institute imeni A.F. Ioffe and "Fizintekh"

MGP consists of the development, based on the customer's requirements, and the delivery of a manufactured model of the device, fulfillment of ordered research, organization of joint production and sale of NPA-EKO on the world market.

Our address: NPO "Uran", 24 B. Sampsoniyevskiy Prospect, St. Petersburg, 194175.

Telephone: 542-44-36, teletype 1213388 More [Sea].

COPYRIGHT: "Tekhnika i vooruzheniye", 1992

Russian Cocom to be Established

*92UM1240A Moscow KOMMERSANT in Russian
No 24, 8-15 June 92 p 12*

[Article by Aleksandr Safronov: "Russian COCOM Can't Exist in a Single Country Either"]

[Text] Russia, it seems, will soon get its own COCOM—a system of controls on exports of technologies and materials that can be used to produce weapons. The existence of such a system will enable Russia to join the international COCOM and to actively trade in technologies with the Western countries. However, in the opinion of specialists, effectively monitoring the export of "dangerous" materials and technologies from Russia is possible only with the participation of the other CIS states. Last week the Russian Federation Ministry of Economics completed the drafting of an agreement on coordinated actions by the CIS states and Georgia in the field of export controls.

Kommersant has learned that the Russian Ministry of Economics is drawing up lists of technologies, raw materials, and equipment whose export is prohibited. These lists are analogous to those of COCOM. The controls will affect technologies and materials that can be used to produce weapons of mass destruction, as well as dual-use defense technologies that can be used to produce delivery vehicles for such weapons. The lists are being drawn up in accordance with the Russian Federation presidential decrees "On Measures to Create a System of Export Controls in Russia," No 338, of March 11, 1992, and "On Controls on Exports From Russia of Nuclear Materials, Equipment, and Technologies," No 312, of March 27, 1992. In the third quarter of 1992, the lists are to be submitted to the Russian parliament for approval.

However, even if Russia sets up its own COCOM, the problem of export controls will not be solved completely: Customs controls along its borders with the other CIS states are lacking. According to officials of the Russian Federation Ministry of Foreign Affairs export controls directorate, in order to solve this problem, the Ministry of Economics, in conjunction with the Foreign Ministry, has drafted an agreement on coordinated efforts by Russia, the other CIS member states, and Georgia on

export control matters. It is envisioned that the participating states will implement a uniform policy in the sphere of technology exports and use common lists of restrictions.

Spokesmen for the Russian Federation Foreign Ministry reported that COCOM experts are prepared to assist the CIS states in setting up an export control system. To this end they have proposed the creation of a coordinating mechanism in which the CIS countries would participate (see KOMMERSANT, No 23, p. 22). As the COCOM experts see it, the "forum for cooperation on export controls" will help standardize the control systems being set up and establish controls on the possible reorientation of technologies for military purposes. The forum would actively enlist intelligence agencies in analyzing specific companies and entrepreneurs whose activities are at odds with COCOM.

The Russian Foreign Ministry spokesmen did not deny that Russia's joining the forum could lead to the cancellation of certain deals, but in their opinion, the benefits from possible subsequent admission to COCOM and access to advanced Western technologies would very much offset these losses. The Foreign Ministry spokesmen also said that Russia is prepared to provide guarantees that it will not use any Western technologies so obtained for military research and will see to it that they are not transferred to third countries.

The telephone number of the Russian Federation Ministry of Economics is (095) 292-39-04.

Ryazan Defense Industry Workers Threaten "Civil Disobedience"

*924A1513A SOVETSKAYA ROSSIYA in Russian
2 Jul 92 p 2*

[Article by V. Kolovov: "On the Eve of Bankruptcy"]

[Text] About a dozen of the largest enterprises of Ryazan sent their representatives to a meeting that was held on Ulitsa Svoboda [Freedom Street] under the windows of the House of the Soviets. As the leader said, the participants were those who are still managing to produce physical assets, frequently to the detriment of their plant. They came primarily from the collectives of the enterprises of the so-called defense complex that were forced to close between 1 June and 6 June, for two months for the present. But what should be done and how are they supposed to live when this time passes? This was the only question on the agenda of the meeting under the open sky.

The representatives of the labor collectives had the facts in hand to show the deep impasse into which their enterprises had been driven by the economic policy of the destructive government of Yeltsin and Gaydar. The introduction of prepayment for deliveries is the latest blow, after which it appears that domestic industry will finally give up the ghost. This, according to the speakers, will make the enterprises truly bankrupt.

At the meeting, a declaration was read to B. Yeltsin, R. Khasbulatov, and Ye. Gaydar and they nearly unanimously passed an addendum to it, in which the meeting supported the appeal of 500 enterprises of the country's defense and machine building complexes. The meeting demanded that the leadership of the Russian Federation take measures to overcome the critical situation in industry, the repeal of the decree on bankruptcy, and the stabilization of prices. Otherwise the labor collectives will be forced to take constitutional measures in defense of their rights even to the point of civil disobedience.

DOCTRINAL ISSUES

Conference on Russia's Military Policy

92UM1211A Moscow KRASNAYA ZVEZDA in Russian
4 Jul 92 First edition p 2

[Article by Major A. Yegorov, KRASNAYA ZVEZDA correspondent, under the rubric "A Conference in the Russian Academy of Sciences": "There Were More Declarations Than Recommendations"]

[Text] A two-day scientific and practical conference on the subject Russia's Military Policy and Securing the Society's Social Stability was held on 30 June and 1 July in the building of the Presidium of the Russian Academy of Sciences. It was arranged at the initiative of the Institute for Social and Political Research of the RAN [Russian Academy of Sciences], Moscow State University imeni M.V. Lomonosov, the Military for Democracy movement, the military department of the Political Science Association and the Association of Military Sociologists. Participating in the conference were representatives of a number of parties and public movements, the Gorbachev Foundation and commercial structures.

According to V. Serebryakov, vice president of the Political Science Association, who presented the report, the conference was conceived to supplement conferences of the Ministry of Defense of the Russian Federation recently held at the General Staff Military Academy. (KRASNAYA ZVEZDA reported in detail on one of them, on the subject Russia's Military Security, in the 2 June issue for this year). But while that was a view of the army from within, this forum represents society's perspective. The scientist feels that combining them will provide an opportunity to shape common approaches to the development of military policy, which has moved to the fore in our state.

The state's inaction in the military area has led to the development of duplicate structures capable of conducting and actually conducting large-scale combat operations. At one time M. Gorbachev proposed taking united action to disband them, but he did not initiate such action for fear of casualties. Thousands are dying today. Within the territory of the former Union there are 180 potential tension spots, at least a third of them in Russia. There are 30 million weapons in people's hands, the bulk of them at the disposal of 600 formations. Can the state be controlled in such a

situation, when we have not yet worked out the system of employing force? And just what should Russia do specifically with respect to the conflicts in Ossetia, Nagorno-Karabakh and Moldova?

Opening the conference, G. Osipov stated that the scientists and politicians assembled in the Academy of Sciences would find answers to these questions and work out specific recommendations for the state's leaders. Five round-table groups were set up at the conference for this purpose. They were headed by prominent scientists: Professor V. Kovalevskiy, doctors of sciences O. Belkov, O. Rzhnevskiy and V. Ivanov, and Candidate of Sciences Yu. Deryugin. No recommendations were arrived at, however, apparently because the scientists expressed diametrically opposite opinions during the debate which ensued. At any rate the journalists did not hear of any at the press conference. There were more than enough political declarations, however. One of the main ones was a demand that the public immediately set about forming a civilian Ministry of Defense.

If the purpose of the conference was to publicize precisely this idea, then the haste with which it was conducted is perfectly understandable. But is that any kind of constructive cooperation between "civilian" science and military scientists, and particularly the Ministry of Defense of Russia?

MILITARY CONFLICT, FOREIGN MILITARY AFFAIRS

Development of Troop Command and Control

924C1785A Moscow VOYENNY VESTNIK
in Russian No 6, Jun 91 pp 78-80

[Article by Candidate of Military Sciences Lieutenant Colonel V. Rubashkin: "Development of Troop Command and Control: Part 1. Global Automation"]

[Text] (Based on Foreign Press Articles)

Part 1. Global Automation

In accordance with the regulations of the U.S. Army and other NATO countries, troop command and control is viewed as a single process during which the activities of division-sized and smaller units and subunits are organized. A command and control system developed based on comprehensive automation is its material foundation.

The significance of automation for the combat potential of troop formations is continuously increasing. So, by 1995 a fourfold increase (from five to 20 percent) of the fraction of command and control systems is anticipated in the total capabilities of the U.S. Army. This logically ensues from the many years of research work on the development of national combat command and control systems in the NATO countries. (See the table).

Country	Designation	Purpose
United States	MCS	Automation of troop maneuver command and control
FRG [Federal Republic of Germany]	Geros	Automation of staff work
Great Britain	Bazel	Automation of combined arms subunit command and control

Various types of automated command and control systems were accepted into the inventory at the beginning of the 1980's. A new concept for their development was worked out based on the results of practical operation. In the U.S. Army, the principles of a hierarchy (with the observance of a subordination on various levels of command and control subsystems), integration (the organizational-technical and functional union of the most important components of the system), modularity (based on widely used commercial computers), and unity of software (the use of the ADA high-level language) were laid at the foundation of the future automated command and control system.

The United States, as the largest military power, is the head developer of the base systems for all NATO countries of ATCCS (Army Tactical Command and Control System) and SPADDS (Staff Planning and Decision Support System). At the same time, research is continuing in the sphere of surveying the possibilities of introducing 5th generation computers and elements of artificial intelligence into automated command and control systems.

American experts have substantiated the need for automated command and control systems through specific calculations. For example, a typical army corps consists of three-five combined arms divisions, corps artillery (approximately 20 battalions), an independent armored cavalry regiment, a brigade—army aviation, PVO [Air Defense], engineer, communications, intelligence and electronic warfare, and other division-sized and smaller units. A total of 3- 5 division headquarters, 30-45 brigade headquarters, and 130-210 battalions can be the subject of command and control within a corps. As for spatial scale, combat operations are conducted in a 50-120 kilometer strip at a combat formation depth of 90-120 kilometers. The destruction of the enemy is possible at a depth of up to 150 kilometers and monitoring him—at a depth of up to 300 kilometers. Planning time should not exceed 72 and 96 hours, respectively.

According to the assessments of American experts, staffs spend up to 75 percent of their time working out decisions on information and calculating work. Only about 30 percent of the incoming information, of which only 10 percent has practical value for making a decision, is used with conventional information processing at the headquarters of tactical elements.

So, the American command authorities have arrived at the conclusion that only a new generation automated command and control system is capable of increasing the effectiveness of command and control by a factor of 2.5-3 which is considered to be minimally necessary for the successful conduct of an air-land operation. Existing automated command and control system models do not totally meet these requirements and need to be improved. Therefore, the MCS [Maneuver Control System] troop maneuver automated command and control system is assessed as an intermediate variation during the shift to the future ATCCS system. Let's look at it in more detail (See Fig. 1).

According to the developers' design, it consists of five subsystems that are joined and functionally unified according to the Sigma Star principle: MCS troop maneuver; ASAS [All Source Analysis System] intelligence and electronic warfare; AFATDS [Army Field Artillery Target Detection System] (replaces Tacfire) field artillery; FAAD [Forward Area Air Defense] air defense, and CSSCS [Combat Services Support Control System] Rear Services Support.

The troop maneuver subsystem is the leading element and unites the efforts and uses the information of the other subsystems. In the process, the command and control cycle is reduced from 16 to 6 hours in an army corps and from 11 to 3.5 hours in a division. The frequency of complete information renewal is: 2-4 hours in a corps (at a depth of up to 300 kilometers), 60 minutes in a division (at a depth of up to 150 kilometers), and 30 minutes in a brigade (at a depth of up to 70 kilometers).

An important place is assigned to the intelligence and electronic warfare subsystem. It is called upon to become the primary supplier of comprehensive information on the enemy in front of the front and on the flanks. It is assumed that up to 4,000 formal reports per hour will be processed. ASAS will support J-STARS unified target reconnaissance system, the Quick Look Radio and SIGINT Reconnaissance System, and others.

The Army Data Distribution System (ADDS), Mobile Subscriber System (MSE), and SINCGARS single-channel UHF radio-communications system link ATCCS facilities.

They propose organizing all of the subsystems on the principle of typical modules, the foundation of which will be ordinary personal computers. They are based on commercial models that have been developed to provide transportability, protection, and expanded memory (up to 125 Megabytes). This permits the use of a single software package, rejects the development of special, expensive, military computers and substantially simplifies the training of personnel.

Figure 1.

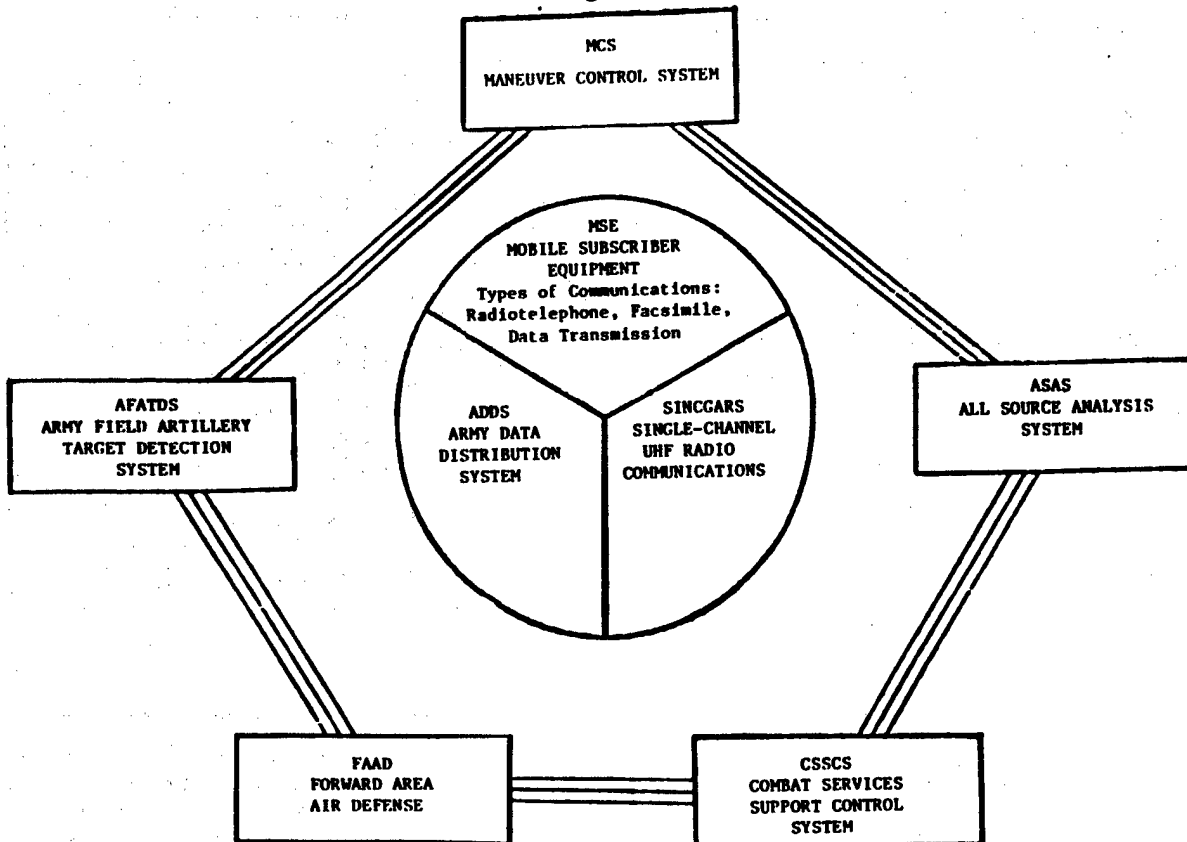

At the present time, such functions have been automated as situation tracking and making working maps; preparation, processing, and distribution of documents; depiction of data on displays; and, processing graphics information. The opportunity to input information using voice and to extract it using a voice synthesizer will appear with the introduction of fifth-generation computers. As a result, the time of its initial processing will be reduced by 60-70 percent (at a reading speed of 120-130 words per minute).

They propose realizing the concept set forth above in three stages (see Fig. 2). In the first (1990-1992), they plan to modernize the troop maneuver and field artillery automated command and control systems, introduce the Forward Area Air Defense automated command and control system and the new rear services support automated command and control system, and to partially deploy the intelligence and electronic warfare automated command and control system. In the second stage (1992-1996), shift to a fully-equipped, integrated automated command and control system in the Sigma Star diagram. In the third stage (1996-2000), they envision linking with the national automated command and control system and the further development of the modular principle of construction based on new commercial computers.

Summing up what has been said, we can formulate the principles of the U.S. Army command authorities global approach to the development of troop and weapons automated command and control: unification of various automated command and control subsystems into a single comprehensive automated command and control system with five primary spheres of tactical element combat operations (ATCCS); structural unification of all subsystems (comprehensive systems) of various levels (from a battalion to an army corps); adoption of the company (battery) level as the source for obtaining leading automated information; and the designation of the troop maneuver automated command and control system (a combined arms automated command and control system subsystem—the Author) as the foundation for ATCCS; integration of the intelligence and electronic warfare subsystems to increase the effectiveness of information support of all subsystems; and, modular construction of the various (various leveled) automated command and control systems. As for the equipment, the automated command and control systems will consist of the latest information processing systems (synthesized speech and elements of artificial intelligence). In the process, they are setting the task of maximally utilizing existing typical models of personal computers with their insignificant modernization.

So, while considering the reduction of ground forces combat components during the course of the realization

Figure 2.

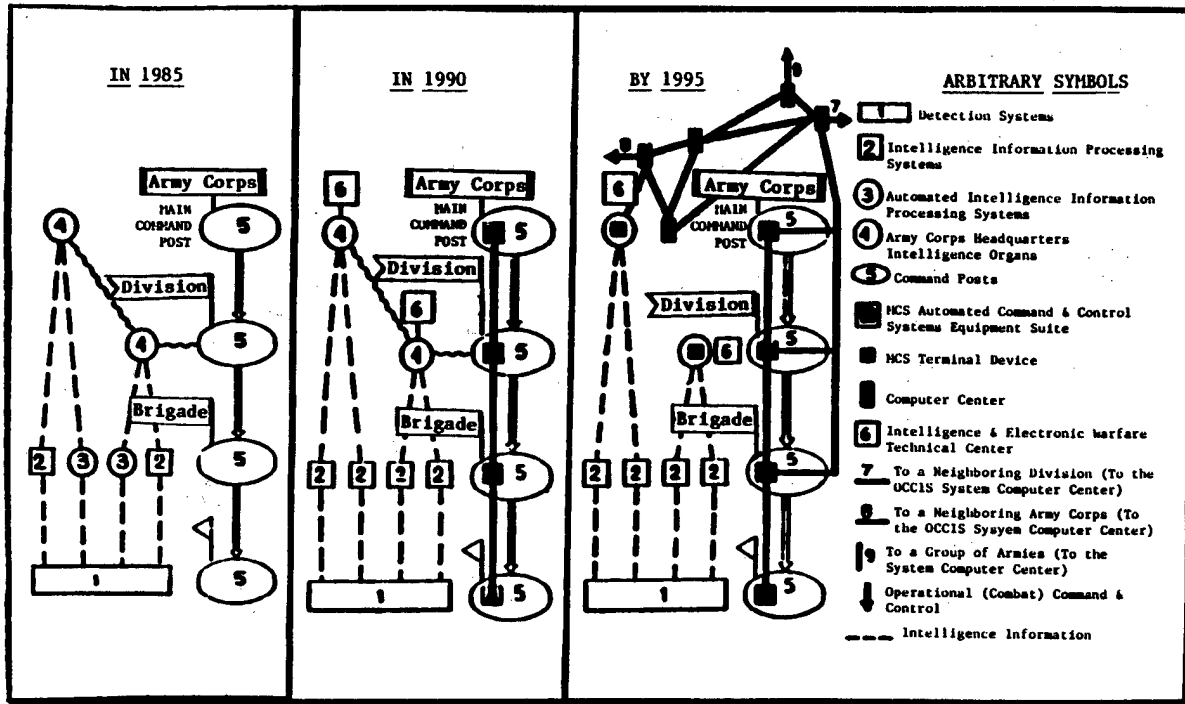

of the Paris Treaty [CFE] and their probable reduction, the U.S. and NATO army command authorities are attempting to preserve combined combat potential first of all through a drastic increase of command and control efficiency.

(To be continued)

COPYRIGHT: "Voyenny vestnik", 1991.

U.S. Ballistic Missile Control Systems

92UM1205A Moscow *TEKHNIKA I VOORUZHENIYE* in Russian No 3-4, 92 pp 36-38

[Article by Col A. Borisyuk, candidate of technical sciences: "U.S. Ballistic Missile Control Systems"]

[Text] Besides the basic task of providing flight control to ensure hitting the target with a desired degree of probability, control systems of U.S. ground-launched and sea-launched ballistic missiles also help to accomplish a number of individual tasks: exchanging information with external equipment on the technical condition of the missile systems and on the results of self-tests; automatic search for malfunctions in missile and launcher equipment; receipt of commands from combat command and control and communications equipment for target designation, calculation, formation, and input of the flight mission to missile; ensuring formation of battle formations; and guiding the warheads to the targets.

As one of the basic components of the system, rigid requirements are placed on the control system of strategic missiles for accuracy, weight, (in a number of cases cost,) and reliability, which must not be below the required level, taking into account the wide range of changes in the parameters characterizing the conditions of combat employment, including the kill mechanisms of a nuclear burst.

The MX missile system is the latest land-based intercontinental ballistic missile [ICBM] put into service in the United States. Its control system includes two basic functional systems: guidance and stabilization. It also has several auxiliary systems: power supply; thermostating; safety against unauthorized launch; protection and recovery of information under the effects of kill mechanisms of a nuclear burst.

The guidance system computes the missile's flight path, determines its position and speed, and generates control commands for thrust vector orientation of the propulsion unit and also one-time commands necessary for the functioning of all systems and devices in a specific sequence: for separation of the stages, release of the warhead nose cone, jettisoning decoy targets, and so forth.

The stabilization system ensures stable flight. The MX uses an effective direct guidance algorithm based on predicting the coordinates of the warhead impact points and adjusting the direction of thrust vector given the expected miss. Missile stabilization takes place relative

to the center of the masses according to angular parameters of pitch, yaw, and rotation. The auxiliary systems ensure normal functioning of the guidance and stabilization systems.

For multiple-element combat equipping, the required amount and direction of velocity vector at the moment of separation of the warheads are ensured by operation of the final stage of the MX—the MIRV stage. To jettison each unit, it moves sequentially to the separation points and orients itself. After separation from the stage, the units for increasing accuracy are spun by special micro-engines mounted on their bottoms.

Since there also may be intermediate non-powered portions of the flight in the MIRV, the engine of the MIRV stage is capable of accomplishing repeated "on-off" cycles. The warheads are equipped with a ballistic cap, a fuse with an arming device, and may be equipped with an antenna.

To simplify the design of actuators and increase the reliability of the control system, in the third stage of the MX missile the engine does not shut off until total burn-out. Hitting the target when firing at minimum ranges is achieved by the fact that the control system determines the invariant direction, movement which does not result in deviation of the warheads from the aiming points. The same algorithm is implemented on Trident missiles at the end of the boost phase.

The basic elements of the control system are: the command box system with electronic units, designed to measure the missile's velocity vector increment and determine its angular orientation; the onboard digital computer system, electronic actuator elements converting the digital codes at the output of the onboard computer into control signals that can be recognized by drives and pyrotechnic elements; actuator elements (propulsion unit drives, pyrotechnic elements); onboard batteries for supplying power to all electrical energy users in flight; the electrical power supply switching and distributing unit; the warhead coupler unit; cooling system reservoirs, pipelines, and fans.

The onboard digital computer system is a single-channel general-purpose digital computer with random information access and is structurally and algorithmically protected from special effects. It is made based on components of small- and medium-scale integration well assimilated by industry. It ensures implementation of all algorithms both in preparatory modes (calibration, adjustment of sensing elements of the command box system, flight mission input, testing equipment of the control system and related systems) and in flight (guidance, stabilization, issuing time commands to the pyrotechnic devices, performing self-tests, organizing control of the computational process).

A number of designs are implemented in the control system of the MX which were not used in earlier-generation missiles. In particular, the configuration of the MIRV stage has been improved, which has made it possible to reduce

Instrumentation Section of the Minuteman-3 Missile

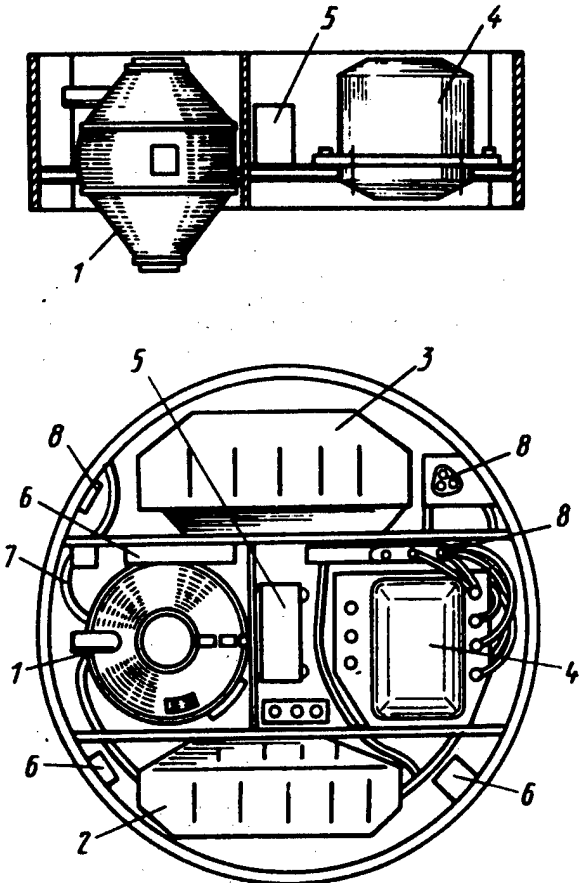

Key:

1. Gyrostabilized platform [GSP]
2. GSP electronics unit
3. Onboard digital computer system
4. Amplifier unit for actuators of control surface elements
5. Power supply battery
6. Sensors of kill mechanisms of nuclear burst
7. Cooling system pipeline
8. Cable straps and connectors

substantially the time for correcting malfunctions. In addition, it uses a command box system with a gimballess mount, and components of the system are calibrated continuously with an increased number of checked parameters. The equipment is liquid-cooled in flight.

The changes in the configuration of the MIRV stage lie in the fact that for the first time a large portion of the control system components, on which the reliability of the missile system basically is dependent, are combined in a replaceable module weighing about 200 kg. If necessary, it can be replaced through a hatch without disconnecting the warheads. Implementation of this idea became possible due to miniaturization of equipment

External View of Gyrostabilized Platform of Minuteman-3 Missile Control System

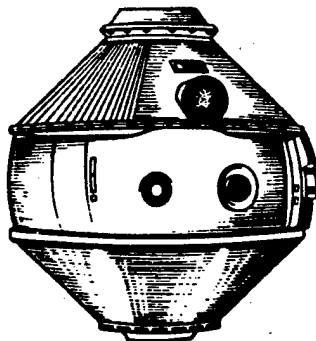

assemblies and high reliability of the component base, not requiring multiple redundancy.

The control systems of other American missiles do not differ much in size and are housed in cylindrical compartments. However, they do not provide for the possibility of replacing malfunctioning equipment in them. Thus, the instrumentation section of the Minuteman-3 is 0.76 meters long and 1.32 meters in diameter. Equipment performing simpler tasks compared to that of the MX missile weighs approximately 155 kg.

Missile Characteristics

Type of Missile	Type of Control System	Firing Accuracy (CEP), meters	Control System Reliability in Flight
Minuteman-2	Inertial	280	0.96
Minuteman-3	Inertial	220	0.98
Trident-1	Astroinertial	450	0.96
Trident-2	Astroinertial	130	0.96
MX	Inertial	90	0.98

The command box system of the MX missile is an inertial measuring unit based on a gimballess gyrostabilized platform. It is made in the shape of a sphere with floating mount, which ensures nearly isothermic conditions. The measuring unit is designed to operate at any orientation of the missile, since it has no limits on pumping angles. The liquid in which the stabilized platform floats effectively protects it from high-frequency shocks and vibratory loads. The suspended sphere with the inertial instruments and internal hydraulic system housed in it is made from a beryllium billet (more than 400 production operations are performed for these purposes). The structure has high strength and low weight. The floating sphere is located inside a stainless steel sphere which serves as its outer shell.

Near the center of the inner sphere is a turbopump which continuously feeds the liquid (19 liters/minute) to eight

couplings. Part of the liquid, passing through them and striking the outer shell, keeps the platform in a suspended state. The rest of the liquid is carried to six jet passages designed for attitude control of the platform.

The inner sphere is girdled by three bands which act as a position sensor stator. One of the bands lies on the equator, and the other two are at right angles to it, displaced 90 degrees to one another. Signals generated by the stator bands come off the rotor element of the sensor, made in the form of a band positioned on the equator of the inside of the casing. In flight, orientation of the casing corresponds to the actual spatial position of the missile.

Instrumentation Section with Removable Pod

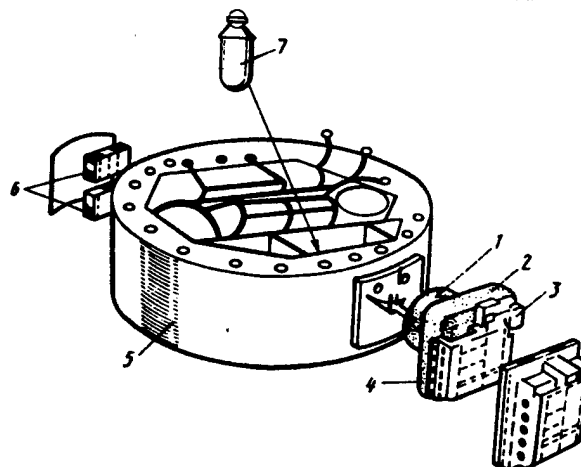

Key:

1. Command box system based on AIRS [expansion not given] gyrostabilized platform
2. Electrical power supply switching and distributing unit
3. Unit for removing safety and arming pyrotechnic devices
4. Onboard digital computer
5. Instrumentation section
6. Onboard batteries
7. Cooling unit

Mounted on the platform are three floated gyroscopes, which stabilize it, and three integrating accelerometers, which measure phantom velocity increment. The electrical connection between the inner and outer spheres is accomplished by means of special brushes.

Each of the six sensing elements mentioned above is housed in its own section of the sphere together with electronic circuits for primary information processing and local control and is covered by a removable cover. There are heat exchangers on the outer surface of the casing. The entire inertial-measuring unit is enclosed in an aluminum housing, which is mounted on a heavy-duty mounting ring. It weighs a total of about 50 kg.

Unlike the MX missile, the Minuteman control systems use a three-axis gimbal mount (32 kg), and the Trident missile uses a four-axis mount with spherical frames. Another specific feature of the command box system of submarine-launched Trident missiles is the presence of an astrocorrection circuit, which increases navigation accuracy and compensates for the effect of errors in determining initial data underwater.

U.S. Navy experts are considering two basic methods of increasing firing accuracy for Trident missiles with the astroinertial system: improving the system itself and using warhead homing algorithms in the terminal phase. To implement the first direction, it is planned to use in the optical system sensors on instruments with a charge connection or on instruments with an injected charge, as well as mechanical elements of third-generation gyroscopes and new types of accelerometers. Homing systems require stable external information sources and all-weather active-type homing sensors with a high degree of protection. American experts believe that terrain-contour matching guidance systems used on Pershing-type ballistic missiles and long-range cruise missiles ultimately may be modernized to such a degree that they will also be used for submarine-launched strategic missiles.

The onboard digital computer on the MX missile is the same as on the Minuteman-2 and Minuteman-3—a specialized single-processor general-purpose computer.

However, it possesses better characteristics. Its speed is 180,000 operations per second for a special mix of operations to be performed, including 32-bit fixed-point computations; 32-bit floating-point computations; and 48-bit increased-accuracy computations. It weighs 63 kg and occupies a volume of 85 liters.

The computer uses three types of memory: a 12,000-word read-only memory (on semiconductors), in which flight programs are recorded; a 16,000-word external memory (on magnetic cores) for ground computations, used when running test programs and also when calibrating and adjusting sensor elements of the command box system; a 4,000-word random-access memory (on cylindrical magnetic film). Half of the capacity of this memory is programmed, and the other half is used in flight as on-line memory.

In the onboard digital computer systems of control systems of Trident sea-launched missiles, guidance and stabilization computations are performed by separate units, that is, essentially two highly specialized computers are used. This makes it possible to reduce speed requirements on individual processor devices and simplify the operating system. In this case, however, the overall weight and reliability characteristics of the control system decline.

Output signals from the onboard computer of control systems are fed through matching devices to actuators

External View of AIRS Gyrostabilized Platform

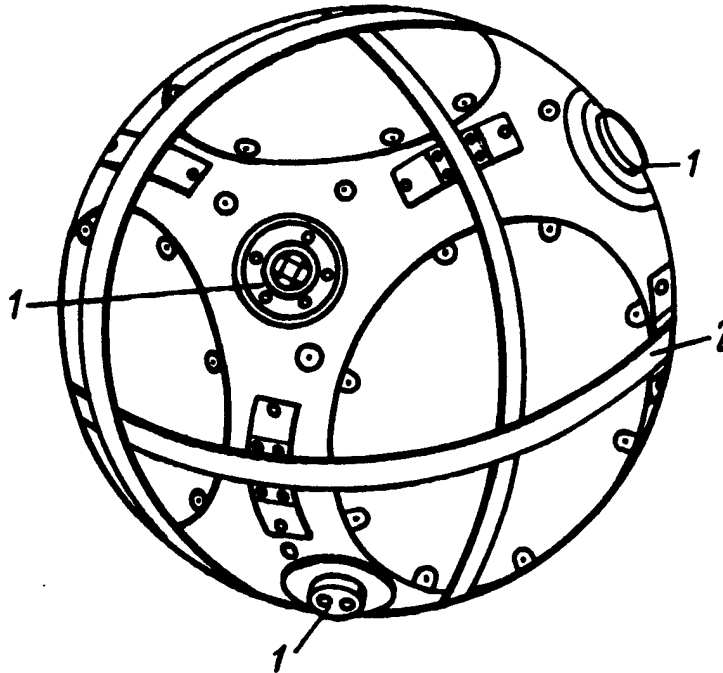

Key:

1. Units of hydraulic centering devices and current-collecting brushes
2. Band-type three-coordinate capacitance-type attitude sensor

controlling movement of the rotating nozzles (the deflection angle of the rotating nozzles of the MX missile does not exceed ± 6 degrees at an angular velocity of 40 degrees/second) or injecting freon into the supercritical part of the combustion chambers if the nozzles are stationary (second and third stages of the Minuteman-3 missile).

It should be noted that the control system designers of American intercontinental ballistic missiles virtually do not use large-scale and extra large-scale (LSI and ELSI) integrated circuits, preferring instead well-developed components of medium-scale integration. The most complex integrated circuits of the MX are the components of the 1,000-bit read-only memory storage unit which contain up to 1,800 gates on one crystal. The reason for this is believed to be the high cost of developing specialized LSI circuits and the complexity of adapting them when modifying and improving logic and schematic diagrams of individual devices of the control system. There are no plans in the future for widespread use of such circuits, since the new component base with an improved production technology must correspond to the increasing requirements for the equipment's resistance to the effects of gamma radiation, neutron flow, various types of X-radiation, and the like.

For protection from the destructive effects of super-hard X-radiation and gamma radiation, the gold conductors in the control systems of MX and Trident-2 missiles have been replaced with more resistant aluminum ones. The normal temperature conditions of operation of the electronic components in the structures of the instrumentation sections are ensured by protecting against convective and radiant heating caused by the escaping stream of gases during operation of the power plant of the last stage. On Trident missiles, cork sheets serve as heat protection for the brackets, electronic equipment, cables, connectors, and other components. Gaps between them in excess of 1.5 mm are filled with cork packing, and smaller gaps are filled with a special resin with cork crumbs.

COPYRIGHT: "Tekhnika i vooruzheniye", 1992

Commentary on Suggestion for Permanent UN Armed Forces

*92UM1212A Moscow KRASNAYA ZVEZDA in Russian
4 Jul 92 First edition p 2*

[Article by Aleksandr Golts, KRASNAYA ZVEZDA commentator, under the rubric "Subject of the Week": "A World Army for a World Government?"]

[Text] Peace is nothing other than a brief interval between wars. Sadly, this rather pessimistic maxim is being confirmed by the present state of affairs in the international arena. The global cold war had not even ended, when it was replaced by several very "hot" wars simultaneously in several parts of Europe. And if, during the years of confrontation, the world community learned after a fashion to avoid war between East and West, the

UN, CSCE [Conference on Security and Cooperation in Europe] and other international institutions have demonstrated complete helplessness in resolving national and ethnic conflicts.

It would not be correct to believe that the world community prefers to stand idly by, however. Various alternatives for responding to new challenges of the times were vigorously discussed this week as well. One option was described in a report by the Secretary General of the UN. In order to enhance its effectiveness in the prevention of conflicts, its peacekeeping activities and operations in support of peace, B. Ghali proposes the establishment of permanent UN armed forces under the Security Council. The UN members would allocate special contingents, out of which a multinational military grouping could be formed in a matter of hours and not several months, as is the case now. Preferably, these forces would be used in a preventive way, before the flames of conflict flare up. It is also proposed that special international military subunits be formed with the mission of restoring and maintaining peace in hot spots.

Although this is not directly stated, it follows from the report that the "UN permanent army" has to be vested with new prerogatives far broader than those possessed by the present "blue helmets." B. Ghali had a reason for stating in a NEWSWEEK interview that the availability of such forces would impart greater persuasiveness to pressure exerted by him upon individual countries: "When I say 'If you behave improperly, I shall be forced to do such and such,' the countries know that the action will take months. Everything would be different if they knew that I had at my disposal soldiers who could be deployed within 24 hours." B. Ghali feels that these forces could be used for repelling a military threat of a certain scale.

The fact that this idea is being considered is confirmed by the fact that Russia's Ministry of Foreign Affairs is actively working out a proposal for allocating a contingent to multinational forces of the CIS or the UN and the CSCE, which could act on a volunteer basis not only to separate hostile parties but also to establish peace in our own hot spots.

This idea is actually already being implemented—not yet in the CIS, to be sure, but in Yugoslavia. A number of states have stated openly that they are prepared to provide military cover for the delivery of humanitarian aid to Bosnia and Herzegovina. The Pentagon, for example, has announced its intentions to activate aircraft of the U.S. Air Force, both for delivering food and medicine to Sarajevo and to cover the operation. The U.S. Navy also has ships carrying Marines in the Adriatic Sea. It was announced that Navy aircraft and Marines could support such actions from the sea. At the same time a Pentagon representative persistently underscored the fact that such an operation is possible only as part of an international effort and under the aegis of the UN or some other international organization.

And so, the idea of establishing a "world army," which, to be frank, would assume the role of world policeman, appears to have fallen onto fertile soil. In fact, is the establishment of such a system perhaps not the only way to break the endless chain of conflicts in which parties at odds cannot reach an agreement?

Perhaps so, but I have to point out something else as well. There was a reason why the UN limited its military activities to maintaining peace. Other forms of intervention tried in the Congo and in Korea did not earn glory for those who operated there under the UN flag. The UN troops were essentially drawn into full-scale wars. Some people will take exception, saying that this occurred during the era of confrontation, when every regional conflict was a result of the opposition between East and West.

But then the disappearance of confrontation certainly did not result in the disappearance of national interests. Just look at how persistently certain nations are trying to participate in peacekeeping operations. We have the FRG and France jointly establishing an army corps whose most important missions are being called peacekeeping operations and humanitarian actions. Despite enormous opposition in the parliament, the Japanese government is literally pushing through a decision for the self-defense forces to take part in operations in support of peace.

While giving credit to these nations for their peacekeeping fervor, I would point out that it is not entirely selfless, to put it mildly. Everyone knows that the constitutions of the two nations forbid the use of national armed forces outside their borders. Participation in peacekeeping operations is a fine pretext for getting around this ban and at the same time enhancing their political status.

But why have we decided that other states will selflessly send their soldiers to engage in what are actually military operations? There can be no doubt that this will be done only if those powers whose viewpoint currently prevails in the Security Council are interested in operations to establish peace. Those which essentially claim to be peaceful governments.

At the same time there are no guarantees that the parties involved in the conflicts will not regard the international forces as aggressors. And the possibility is in no way ruled out that the deployment of UN peacekeeping forces will result not in pacification but in a further escalation of force.

During the meeting of the recently established Council on Russia's Foreign Policy I asked Ye. Ambartsumov, chairman of the Committee on International Affairs and Foreign Economic Relations of the Supreme Soviet of the Russian Federation, and V. Zhurkin, director of the Europe Institute of RAN [Russian Academy of Sciences], how they felt about the idea of forming international forces for the establishment of peace. The two

well-known political scientists agreed that if the establishment of such forces were possible, it should only be under a rigid UN mandate which would regulate their actions precisely. There are probably opposite opinions as well. It is also obvious that the idea must be worked out very seriously and should absolutely not be implemented immediately.

SECURITY SERVICES

Ukrainian Border Guards: Rising Illegal Immigration From Asia

92UM1243A Kiev NARODNAYA ARMIYA in Russian
24 Jun 92 p 1

[Ukrainian Border Guard official V.D. Bulin interviewed by Ukrainian Border Troops press service: "Ukraine Is No Revolving Door, Or How to Counter Illegal Immigration"]

[Text] The transparency of the "borders" between the CIS states is increasingly leading to tension on Ukraine's state border. In May alone, dozens of transgressors from the Asian region were detained on the Western border and at border-crossing points. And their numbers are growing with each passing day.

The Ukrainian Border Troops press service asked Colonel V.D. Bulin, deputy chief of staff and head of the border control directorate of the State Committee for Protecting the Ukrainian State Border, to respond to questions of interest regarding this important problem.

[Press service] Valeriy Dmitriyevich, as we know, the situation along Ukraine's state border has become sharply exacerbated of late in connection with illegal immigration by citizens of third countries. What has prompted this?

[Bulin] The fact is that Ukraine, by virtue of its geographic position, is one of the states lying on the path of illegal immigration by citizens of Southeast Asian states to the countries of Western Europe. The most active routes for this immigration are border-crossing points along the Ukrainian state border. In the past two years, the number of people trying to illegally cross the border has increased by 400 percent. And unfortunately, this trend is continuing.

Attempts to violate the border are most often made by citizens of Vietnam, Pakistan, Sri Lanka, and Mongolia. During the first five months of this year, only 12 percent of all the transgressors detained were citizens of the CIS, including Ukraine. The rest were mostly from Southeast Asia and Africa.

The aim of the illegal immigration is to search for better living conditions, a desire to earn freely convertible currency, and to evade liability for criminal offenses in their countries. And so they use Ukraine's territory as a transit point for subsequently making their way into European countries.

[Press service] On what sections are transgressors working especially hard to "test" the vigilance of our border troops?

[Bulin] This process is especially active on the borders with the Republic of Poland, the Czech and Sloval Federal Republic, and the Republics of Hungary and Romania. Sizable groups of Asian citizens are forming in Ukraine's western oblasts with the aim of crossing the border to the West at any price.

Here's just one incident.

Not very long ago, soldiers from one of the outposts of the Mukachevskiy border detachment detained a group of 28 individuals who were trying to illegally cross the Ukrainian-Hungarian border. The "guests" had arrived in Transcarpathian Oblast by train from Moscow, where they had gone as tourists from Sri Lanka. After conspiring with a Hungarian citizen who had volunteered to be their guide, they intended to make their way all the way to Italy.

Instances of this sort on our border are not rare. The number of Southeast Asia citizens detained along Ukrainian borders is steadily growing. After entering other Commonwealth states as tourists or after finishing work under a labor contract, many of the foreigners are unwilling to return to their native countries in the established procedure. They try to travel in hopes of successfully ending their journey somewhere in Germany, Austria, Italy, or Switzerland.

But Ukraine's territory is no revolving door. This is well understood not only by the border troops, but also by residents of the border regions. Incidentally, 20 percent of the aforementioned transgressors were detained with their help. Moreover, Ukraine maintains friendly relations with the adjacent countries, and their border services closely cooperate and help each other in detaining and returning border transgressors. So virtually no one has any chance of crossing the border with impunity.

[Press service] Nevertheless, are there some "well-wishers" who try to help the border transgressors carry out their criminal plans?

[Bulin] Experience shows that a large number of those who are detained try to cross the border using false documents. In the process, they often use the services of con men who claim to give them a 100 percent guarantee of their "creative work." take enormous sums of money from them, and then abandon their "patients" to the whims of fate. There are examples in which criminal

elements have gathered such travel enthusiasts into groups and taken them (again, for incredible amounts of money) to the border, where they are then stopped by the border authorities, their false documents are exposed, investigations are conducted, and they are sent back.

Transgressors often solicit help from local residents along wooded sections of the border. Unfortunately, it must be said that people not averse to making easy money are occasionally to be found among the latter as well. For example, such incidents have occurred in the border regions of Transcarpathian Oblast and in Lvov and Volyn Oblasts.

[Press service] What measures, in your opinion, have to be taken to stop the flow of illegal immigration across the Ukrainian state border?

[Bulin] First of all, it is essential to equip units of the border control service with more modern equipment. Without such equipment, it is very difficult to expose false and counterfeit documents. After all, it's no secret that criminal elements are now using laser technology in forging seals and transposing photographs.

It would also be helpful to train border control personnel on the basis of standardized programs and, when especially necessary, to enlist specialists from other countries in this training. It seems to me that this would greatly increase the reliability of border control.

Second, it is necessary to adopt a legal foundation for combating illegal immigration that would be uniform for all the European countries. Ukraine's laws in this regard are only now being drawn up, and we would like to take into account the experience of other states as we draft them.

Our neighbors have enacted stiffer penalties for violating borders and for aiding and abetting violators. Unfortunately, Ukrainian border troops do not yet have the right to take punitive action against even so-called "malicious" border transgressors, which is to say those who attempt to violate the border repeatedly, who try to block international railroads and incite others to do so, and who do not comply with the legitimate demands of border troops and customs officers.

Over the past year, the Ukrainian State Border Committee has repeatedly submitted proposals for legislation to deal with this issue. Unfortunately, they have not been accepted on the grounds that it is necessary to await the adoption of new codes on criminal and administrative liability for violating legal norms on the border.

NTIS
ATTN PROCESS 103
5285 PORT ROYAL RD
SPRINGFIELD VA

2

22161

This is a U.S. Government publication. Its contents in no way represent the policies, views, or attitudes of the U.S. Government. Users of this publication may cite FBIS or JPRS provided they do so in a manner clearly identifying them as the secondary source.

Foreign Broadcast Information Service (FBIS) and Joint Publications Research Service (JPRS) publications contain political, military, economic, environmental, and sociological news, commentary, and other information, as well as scientific and technical data and reports. All information has been obtained from foreign radio and television broadcasts, news agency transmissions, newspapers, books, and periodicals. Items generally are processed from the first or best available sources. It should not be inferred that they have been disseminated only in the medium, in the language, or to the area indicated. Items from foreign language sources are translated; those from English-language sources are transcribed. Except for excluding certain diacritics, FBIS renders personal names and place-names in accordance with the romanization systems approved for U.S. Government publications by the U.S. Board of Geographic Names.

Headlines, editorial reports, and material enclosed in brackets [] are supplied by FBIS/JPRS. Processing indicators such as [Text] or [Excerpts] in the first line of each item indicate how the information was processed from the original. Unfamiliar names rendered phonetically are enclosed in parentheses. Words or names preceded by a question mark and enclosed in parentheses were not clear from the original source but have been supplied as appropriate to the context. Other unattributed parenthetical notes within the body of an item originate with the source. Times within items are as given by the source. Passages in boldface or italics are as published.

SUBSCRIPTION/PROCUREMENT INFORMATION

The FBIS DAILY REPORT contains current news and information and is published Monday through Friday in eight volumes: China, East Europe, Central Eurasia, East Asia, Near East & South Asia, Sub-Saharan Africa, Latin America, and West Europe. Supplements to the DAILY REPORTs may also be available periodically and will be distributed to regular DAILY REPORT subscribers. JPRS publications, which include approximately 50 regional, worldwide, and topical reports, generally contain less time-sensitive information and are published periodically.

Current DAILY REPORTs and JPRS publications are listed in *Government Reports Announcements* issued semimonthly by the National Technical Information Service (NTIS), 5285 Port Royal Road, Springfield, Virginia 22161 and the *Monthly Catalog of U.S. Government Publications* issued by the Superintendent of Documents, U.S. Government Printing Office, Washington, D.C. 20402.

The public may subscribe to either hardcover or microfiche versions of the DAILY REPORTs and JPRS publications through NTIS at the above address or by calling (703) 487-4630. Subscription rates will be

provided by NTIS upon request. Subscriptions are available outside the United States from NTIS or appointed foreign dealers. New subscribers should expect a 30-day delay in receipt of the first issue.

U.S. Government offices may obtain subscriptions to the DAILY REPORTs or JPRS publications (hardcover or microfiche) at no charge through their sponsoring organizations. For additional information or assistance, call FBIS, (202) 338-6735, or write to P.O. Box 2604, Washington, D.C. 20013. Department of Defense consumers are required to submit requests through appropriate command validation channels to DIA, RTS-2C, Washington, D.C. 20301. (Telephone: (202) 373-3771, Autovon: 243-3771.)

Back issues or single copies of the DAILY REPORTs and JPRS publications are not available. Both the DAILY REPORTs and the JPRS publications are on file for public reference at the Library of Congress and at many Federal Depository Libraries. Reference copies may also be seen at many public and university libraries throughout the United States.