

ABSTRACT

Each year, the UNC-CH Operations Research Department invites community organizations to be involved as clients in the Operations Research Practice course. Interested organizations can volunteer to have a student work on an OR-type problem for them over the course of a semester. The OR Practice course instructor chooses interesting problems from among those submitted and assigns a client to each student.

TITLE:

Cost/Benefits Study on Implementing Mobile Data Terminals in Chapel Hill Transit's Paratransit Fleet

STUDENT:

2Lt Kelly Mirone
Department of Operations Research
University of North Carolina at Chapel Hill
Completed May 30, 1997

CLIENT:

Mr. Scott McClellan
Administrative Analyst
Chapel Hill Transit

SUMMARY:

To address the heavy dispatching workload and communications challenges in its paratransit operations, Chapel Hill Transit (CHT) requested that the Operations Research Department of the University of North Carolina at Chapel Hill conduct a study on the potential costs and benefits of adding mobile data terminals (MDT's) to CHT's current system. A new type of transportation technology, an MDT is a small computer terminal mounted in the vehicle that communicates directly with the dispatcher's central computer via a communications network.

This study addressed this issue. It:

- Evaluated current CHT paratransit operations from four perspectives: dispatcher, driver, customer, and data collection. This was accomplished by observation and quantitative analysis of dispatcher's booth activity; vehicle ride observation; discussion with dispatchers, drivers, and administrators; distribution of a driver survey; and analysis of a finite-source retrieval queueing model.
- Evaluated potential changes in operations due to MDT's from the same four perspectives.
- Researched what steps would be necessary to implement a mobile data system.
- Surveyed different MDT vendors to assess the benefits and costs of each product that was found to suit CHT's needs.
- Analyzed the anticipated costs of adding MDT's.

DTIC QUALITY INSPECTED 2

DISTRIBUTION STATEMENT A

Approved for public release;
Distribution Unlimited

19980109 082

ABSTRACT

Each year, the UNC-CH Operations Research Department invites community organizations to be involved as clients in the Operations Research Practice course. Interested organizations can volunteer to have a student work on an OR-type problem for them over the course of a semester. The OR Practice course instructor chooses interesting problems from among those submitted and assigns a client to each student.

TITLE:

Cost/Benefits Study on Implementing Mobile Data Terminals in Chapel Hill Transit's Paratransit Fleet

STUDENT:

2Lt Kelly Mirone
Department of Operations Research
University of North Carolina at Chapel Hill
Completed May 30, 1997

CLIENT:

Mr. Scott McClellan
Administrative Analyst
Chapel Hill Transit

SUMMARY:

To address the heavy dispatching workload and communications challenges in its paratransit operations, Chapel Hill Transit (CHT) requested that the Operations Research Department of the University of North Carolina at Chapel Hill conduct a study on the potential costs and benefits of adding mobile data terminals (MDT's) to CHT's current system. A new type of transportation technology, an MDT is a small computer terminal mounted in the vehicle that communicates directly with the dispatcher's central computer via a communications network.

This study addressed this issue. It:

- Evaluated current CHT paratransit operations from four perspectives: dispatcher, driver, customer, and data collection. This was accomplished by observation and quantitative analysis of dispatcher's booth activity; vehicle ride observation; discussion with dispatchers, drivers, and administrators; distribution of a driver survey; and analysis of a finite-source retrieval queueing model.
- Evaluated potential changes in operations due to MDT's from the same four perspectives.
- Researched what steps would be necessary to implement a mobile data system.
- Surveyed different MDT vendors to assess the benefits and costs of each product that was found to suit CHT's needs.
- Analyzed the anticipated costs of adding MDT's.

**COST/BENEFITS STUDY ON IMPLEMENTING
MOBILE DATA TERMINALS
IN CHAPEL HILL TRANSIT'S
PARATRANSIT FLEET**

KELLY MIRONE

**DEPARTMENT OF OPERATIONS RESEARCH
UNIVERSITY OF NORTH CAROLINA AT CHAPEL HILL
MAY 30, 1997**

Submitted as an expository paper in partial fulfillment of the requirements
of the degree of Master of Science.

EXECUTIVE SUMMARY

Chapel Hill Transit (CHT) provides various forms of public transportation for the Chapel Hill community. In addition to its broad spectrum of fixed-route bus services, CHT offers demand-responsive services, called "paratransit" services. They meet a wide range of special transportation needs, including service to locations not on any fixed route, travel during off-peak hours, and elderly and/or handicapped transportation. The small size of its paratransit operation allows CHT to accommodate customers as they call on a first-come first-served basis.

During peak times of day, both the level of customer calls and number of trips being accomplished are high. This creates considerable demand on the CHT dispatcher's time. She must answer customer phone calls, book future trips that are being requested, dispatch current trips to vehicles, record information regarding trip execution (i.e., arrival, departure, board, and alight times) for all CHT vehicles on the road, and maintain communication with drivers all at the same time. This excessive workload can affect length of customer phone calls, quality of real-time dispatching decisions, and on-time trip performance.

All dispatcher-driver communication currently occurs over one 450MHz UHF radio frequency. This band is also shared by bus drivers. The high volume of information transmitted and the frequent need to repeat messages can be both frustrating and time-consuming for drivers and dispatchers.

An ideal communications system would:

- Provide dispatchers with adequate time to make better dispatching decisions than the current system permits.
- Speed up effective communication between dispatchers and drivers, and reduce the error rate in communicating between them.
- Offer a higher level of customer service to callers requesting information or booking trips.
- Accommodate the transportation needs of passengers in a more timely manner.
- Generate accurate and informative reports using trip execution times and mileages.
- Provide these improvements at relatively low cost.

To address its dispatching workload and communications challenges, CHT requested that the Operations Research Department of the University of North Carolina at Chapel Hill conduct a study on the potential costs and benefits of adding mobile data terminals (MDT's) to CHT's current system. A new type of transportation technology, an MDT is a small computer terminal mounted in the vehicle that communicates directly with the dispatcher's central computer via a communications network.

This study addressed this issue. It:

- Evaluated current CHT paratransit operations from four perspectives: dispatcher, driver, customer, and data collection. This was accomplished by observation and quantitative analysis of dispatcher's booth activity; vehicle ride observation; discussion with dispatchers, drivers, and administrators; and distribution of a driver survey.
- Evaluated potential changes in operations due to MDT's from the same four perspectives.
- Researched what steps would be necessary to implement a mobile data system.
- Surveyed different MDT vendors to assess the benefits and costs of each product that was found to suit CHT's needs.
- Analyzed the anticipated costs of adding MDT's.

Major findings of this study are:

- Currently, the dispatcher spends an average of 19.4 minutes per hour on the phone or radio.
- *With MDT's, we estimate that this time would be reduced to 11.0 minutes (a 43% reduction).*
- Currently, the dispatcher manually enters all trip data, which is both time-consuming and prone to error in terms of recording trip performance time.
- *With MDT's, trip performance data would be automatically transmitted from vehicle to office, helping to eliminate recording errors and providing additional time for the dispatcher to perform additional tasks.*
- Currently, the use of voice radio causes frequent unsuccessful call attempts and necessitates message repetition.
- *With MDT's, information transfer would occur upon the driver's/dispatcher's first attempt to send trip data.*
- Currently, CHT does not have the means to collect information accurately on trip stop and start times, dwell times, and trip mileages.
- *MDT's would automatically provide a time and mileage stamp with every trip performance. Combined with their user-definable reporting capabilities, they would provide a more comprehensive reporting tool to CHT than it currently has.*
- Implementing MDT's would require acquiring an additional UHF radio channel. The license for a new frequency would cost under \$300.
- Implementing MDT's would require a contract with Trapeze Software Group to interface Minipass, its dispatching software which CHT already has, with the MDT software. This contract would include the interface itself, engineering, and training, and would cost approximately \$32,000 initially, followed by about \$2,000 annually.

- GMSI, Inc. and Mentor Engineering both offer MDT's that would meet CHT's needs. Mentor Engineering provides the more cost-effective option and has more experience in implementing mobile data systems in paratransit operations. The cost of the Mentor contract is about \$34,000 initially, along with an annual maintenance/upgrade cost of \$2,500.
- The costs to implement MDT's would total about \$66,500 initially, followed by about \$4,500 annually.

Based upon these findings, we recommend:

1. CHT should consider MDT's as a good option to improve current paratransit operations in these ways:
 - reduced dispatcher workload, allowing more time for better dispatching decisions and caller service
 - faster, clearer, and less error-prone driver/dispatcher communication
 - more on-time trips
 - trip time and mileage reporting capabilities
2. CHT should decide whether it will make a long-term commitment to using Minipass. If so, it will be in a position to begin the process of installing MDT's. If not, CHT will need to do further research to commit to another dispatching software package before installing an MDT system.

If CHT decides to implement MDT's, we also recommend:

1. CHT should pursue Mentor Engineering as the best vendor option for this system. Mr. Brent Freer, the sales representative we worked with during the study, is the point of contact. CHT should arrange for a visit and presentation from the company.
2. CHT should take early steps to gain the second radio frequency needed for the MDT system. Mr. Dyke Hostettler, State Frequency Coordinator for North Carolina, is the point of contact. It should also contact a radio consultant, possibly Mr. Larry Sparks, to consider the possibility of using his services to ensure an adequate radio system.
3. CHT should begin to work toward a contract with Trapeze Software Group for the MDT - Minipass interface. The point of contact is Mr. Dean Richardson. The contract should contain a commitment from Trapeze to staying until the interface is running smoothly, since CHT would be the first Minipass-MDT interface site.

EXECUTIVE SUMMARY	i
CHAPTER 1: OVERVIEW AND INTRODUCTION.....	1
1.1 PROJECT BACKGROUND	2
1.2 PROJECT OVERVIEW	3
1.3 REPORT OVERVIEW	5
CHAPTER 2: POTENTIAL EFFECTS OF MDT'S ON CURRENT PARATRANSIT OPERATIONS.....	6
2.1 DISPATCHER PERSPECTIVE.....	7
2.1.1 <i>Dispatcher Busy Time - Quantitative Analysis</i>	7
2.1.3 <i>Trip Data Entry</i>	11
2.1.4 <i>Repetitions and Multiple Call-Outs</i>	12
2.2 DRIVER PERSPECTIVE.....	13
2.2.1 <i>Multiple Attempts to Reach Dispatcher</i>	13
2.2.2 <i>Repetitions</i>	15
2.2.3 <i>Vacant Vehicles</i>	15
2.2.4 <i>Attitudes Toward MDT's</i>	16
2.3 REPORTING PERSPECTIVE.....	19
2.3.1 <i>Real-Time Credibility</i>	19
2.3.2 <i>Time and Mileage Stamping</i>	20
2.3.3 <i>Flexible Data Collection</i>	21
2.4 CUSTOMER PERSPECTIVE	22
2.5 SUMMARY	23
CHAPTER 3: MDT IMPLEMENTATION	24
3.1 INVESTIGATION OF MDT IMPLEMENTATION	25
3.2 ACTION 1: COMMUNICATIONS NETWORK ACQUISITION	26
3.2.1 <i>Four Options</i>	26
3.2.2 <i>Recommendations for Accomplishing Action 1</i>	27
3.3 ACTION 2: CONTRACT WITH TRAPEZE	28
3.3.1 <i>Three Issues</i>	28
3.3.2 <i>Contract Costs</i>	28
3.3.3 <i>Recommendations for Accomplishing Action 2:</i>	29
3.4 ACTION 3: CHOOSING AN MDT VENDOR.....	29
3.5 SUMMARY	30
CHAPTER 4: MDT VENDORS.....	31
4.1 HOW VENDORS WERE CONSIDERED	32
4.2 GMSI, INC.	32
4.2.1 <i>About the Company</i>	32
4.2.2 <i>Experience in Paratransit Operations</i>	32
4.2.3 <i>The Product</i>	33
4.2.4 <i>Paratransit Clients</i>	34
4.2.5 <i>Contract Costs</i>	36
4.3 MENTOR ENGINEERING	38
4.3.1 <i>About the Company</i>	38
4.3.2 <i>Experience in Paratransit Operations</i>	38
4.3.3 <i>The Product</i>	38
4.3.4 <i>Paratransit Clients</i>	39
4.3.5 <i>Contract Costs</i>	42
4.4 OTHER COMPANIES	44
4.5 SUMMARY OF FINDINGS	46

CHAPTER 5: RECOMMENDATIONS.....48

APPENDIX A: PHONE AND RADIO ACTIVITY RESULTS

APPENDIX B: CHT PARATRANSIT DRIVER SURVEY

APPENDIX C: MULTIPLE ATTEMPTS TO REACH DISPATCHER -- A CTMC MODEL

C.1 PROBLEM OVERVIEW

C.2 DATA COLLECTION AND PARAMETER ESTIMATES

C.3 SOLVING THE PROBLEM

C.4 SUMMARY OF RESULTS

APPENDIX D: CONTACTS

APPENDIX E: UHF FREQUENCY SEARCH RESULTS

APPENDIX F: MINIPASS/AVL LETTER

APPENDIX G: GMSI MDT FUNCTIONALITY

APPENDIX H: MENTOR CONTACT LIST

APPENDIX I: MENTOR MDT FUNCTIONALITY

APPENDIX J: MENTOR SYSTEM QUOTE

CHAPTER 1:
OVERVIEW AND INTRODUCTION

1.1 Project Background

Chapel Hill Transit (CHT) provides various forms of public transportation for the Chapel Hill community. In addition to its wide range of fixed-route bus services, CHT offers demand-responsive services. These special "paratransit" services meet a wide range of special transportation needs, including service to locations not on any fixed route, travel during off-peak hours, and elderly and/or handicapped transportation. The small size of its paratransit operation allows CHT to accommodate customers as they call on a first-come first-served basis. In addition to dispatching vehicles, the dispatcher takes customer phone calls and schedules trips. With this setup, the system has a great deal of flexibility, but it is also prone to becoming overloaded during peak hours.

All dispatcher-driver communication currently occurs over one radio frequency band. This band is also shared by bus drivers. The high volume of information transmitted and the frequent need to repeat poorly-understood messages often cause delays. Dispatchers spend a significant portion of their limited and valuable time talking over the radio.

Until December 1996, all trip information such as passenger name, pickup time and place, destination, and fare, was logged manually by the dispatcher. CHT has recently begun to use a computer-aided dispatch (CAD) software package called Minipass to record these data. The package has replaced hand-written logs and provides administrators with a helpful reporting tool. However, the dispatcher still has to spend time booking trips and entering trip data into the system.

In recent years, the transportation industry has begun to make use of mobile data technology to improve communications and operational efficiency. Both Winston-Salem and Charlotte have made the decision to implement mobile data systems in their paratransit systems. A principal component of these systems is the mobile data terminal (MDT). It is a small terminal mounted in the vehicle which communicates directly with the dispatcher's computer via some communications network.

Mr. Scott McClellan, CHT's administrative analyst, was concerned about the paratransit system's dispatching overload and communications issues. He recognized that identifying and overcoming these problems would increase customer service and employee satisfaction. He requested that the Operations Research Department of the University of North Carolina at Chapel Hill conduct a study on the potential costs and benefits of adding MDT's to CHT's current system.

1.2 Project Overview

This project involved observing current paratransit service and researching the potential effects of using MDT's in the context of CHT's operational environment. The costs associated with implementing this technology were also assessed.

The evaluation of current paratransit service was accomplished in several ways:

- Spending time in the dispatcher's booth, which included discussion with dispatchers, data collection on radio and phone call activity, and qualitative observation of operations.
- Analyzing radio and call data to estimate dispatcher busy time.
- Riding on paratransit vehicles.
- Conducting a driver survey which addressed issues that came up as a result of vehicle rides.
- Discussing desired reporting capabilities with Mr. McClellan.

The effects of MDT's on the system were predicted by considering observations made about current operations. Dispatcher busy time estimates from booth observations were modified to reflect the use of MDT's, and drivers were surveyed to gauge their response to the possibility of having them on their vehicles. In addition, several cities with systems already in place were contacted in order to learn what benefits and drawbacks they have experienced from using the technology.

Based on our study of current operations, data analysis, and surveys, the study concluded that adding MDT's to the system will benefit CHT by:

- Reducing the percentage of dispatcher's time on phone and radio
- Eliminating the need for dispatcher to manually enter trip data
- Eliminating delays due to message repetitions.
- Eliminating delays due to multiple call-outs by dispatcher
- Eliminating delays due to multiple attempts by driver to contact dispatcher
- Reducing incidence of vacant and idle vehicles
- Inducing positive driver reaction to MDT's
- Improving real-time credibility in reporting trip status to customers
- Enhancing reporting capabilities due to time and mileage stamping
- Improved customer service resulting from each of the above improvements (from the customer's booking phone call to her actual trip).

Additionally, the study involved investigation to discover what actions and costs would be involved in implementing MDT's. This was a multi-step process which included interviews with several people regarding communications network opportunities, MDT vendors, and contracting with Trapeze. One source of costs is the communications

network necessary to transmit data from the MDT to the central computer. Research revealed that CHT would be able to gain a second UHF frequency for an application fee of under \$300. Additionally, a contract with Trapeze will be required to purchase the MDT interface for Minipass and to pay for associated engineering and training. This cost was estimated to be about \$32,000.

Initial contact with several mobile data systems and transportation management companies indicated that two companies offered products that would meet CHT's needs. These needs were defined by the facts that Chapel Hill has a computer-aided dispatch (CAD) system, Trapeze Software's Minipass, already in place, and it has a small fleet.

Both GMSI, Inc. and Mentor Engineering offered a mobile data terminal with software that interfaces with Trapeze's CAD system. The two companies were compared in terms of company background, experience with paratransit systems, experience with Trapeze CAD interface, product specifications and functionality, client feedback, and system costs. Mentor gave an estimate of about \$34,000, while GMSI gave an estimate of about \$47,000. The major difference in price is due to the companies' differing estimates of engineering costs. Overall, the findings of this study indicate that Mentor is the better option for CHT because of its lower cost, experience with paratransit and Trapeze-interfaced systems, and favorable customer response.

In summary, this study finds that MDT's would be of significant benefit to CHT in improving the quality of paratransit operations. Both GMSI and Mentor offer MDT systems which are appropriate for the needs of CHT. This investigation points to Mentor as the better vendor option, and the estimated overall cost of this system would be about \$66,500.

1.3 Report Overview

This report is divided into five chapters. Chapter 2 details findings on the potential effects of MDT's on current operations. Section 2.1 considers these effects from the perspective of the driver. It includes results from the dispatcher "busy time" analysis, including incoming rate of phone and radio calls per hour, average duration of these calls, and percentage of time that the dispatcher is either on the phone or radio. In addition, it addresses trip data entry, radio call repetitions, and multiple call-outs.

Section 2.2 considers the issue from the driver's perspective. It addresses the problems of multiple driver attempts to reach the dispatcher, radio call repetitions, and standing by in vacant vehicles. Finally, it contains results of a driver survey indicating driver attitudes toward the prospect of using MDT's in their vehicles.

Section 2.3 considers the effects of MDT's from a reporting standpoint, including real-time credibility, time and mileage stamping, and flexibility in data collection. Section 2.4 discusses how findings in the previous sections will affect customer service.

Chapter 3 deals with MDT implementation. Implementation actions fall into three categories, which are presented in Section 3.1. Sections 3.2, 3.3, and 3.4 address choosing a communications network, establishing a Minipass-MDT interface contract with Trapeze, and choosing an MDT vendor, respectively. Recommendations for how to best accomplish these actions are summarized in Section 3.5.

Chapter 4 contains detailed results from our research of MDT vendors. GMSI, Inc. and Mentor Engineering are considered in Sections 4.2 and 4.3. Each section contains:

- Information about the company itself
- Information about the company's experience in providing mobile data systems to paratransit fleets
- Description of the company's product
- Comments and contact information from company clients who have MDT's installed on their paratransit fleets

Section 4.4 lists other vendors that were considered, but ruled out early in the process. Section 4.5 summarizes findings and makes a vendor recommendation based on this summary.

Chapter 5 contains a summary of our findings during the course of this project and, based on these findings, makes our recommendations to CHT.

CHAPTER 2:
POTENTIAL EFFECTS OF MDT'S ON
CURRENT PARATRANSIT OPERATIONS

2.1 Dispatcher Perspective

The dispatcher has several responsibilities. He must:

- Answer all demand-responsive customer phone calls. These calls may be requests to book trips up to two weeks in advance, cancel trips, or find out about the status of a trip. There are two customer phone lines for the dispatcher to monitor.
- Maintain communication with all paratransit vehicles en route. The dispatcher tells each driver his or her next destination(s), passenger(s), and where passenger(s) need to go. The driver radios the dispatcher every time she picks up or drops off a passenger and relays name, location, and type of fare paid. The radio is also used to give directions to unfamiliar addresses, confirm driver location, and deal with emergencies.
- Use Minipass dispatching software to accomplish trip-booking and dispatching.
- Dispatch trips. The dispatcher does not use Minipass to assign trips to vehicles ahead of time. Instead, she assigns these trips less than an hour in advance based on real-time activity. This requires both thought and time.

Juggling these responsibilities can be challenging during the busiest hours of the day, as subsequent subsections show. The following subsections deal with how current operations affect the dispatcher.

2.1.1 Dispatcher Busy Time - Quantitative Analysis

CHT initially expressed concern about the “sensory overload” faced by dispatchers on a daily basis. MDT’s might be able to significantly reduce this overload by reducing radio traffic and data entry time.

The primary quantitative analysis was aimed at trying to provide descriptive estimates of the current level of activity in the dispatcher’s booth and the potential change in activity level with the introduction of MDT’s. This was accomplished by estimating current values of:

1. Average rate of radio call occurrence
2. Average rate of phone call occurrence
3. Average radio call duration
4. Average phone call duration
5. Average dispatcher busy time (percentage of the time that the dispatcher is occupied, either by a radio or phone call.)

The projected dispatcher busy time with MDT’s in use was also calculated based upon the duration of current radio calls which would not be able to be handled by an MDT.

2.1.1.1 Data Collection

The goal in collecting data in the dispatcher's booth was to measure phone call activity, radio call activity, and the fraction of the time that these calls occupy the dispatcher. The assumption was that these averages were related to both hour of the day and day of the week. Since no data were available, the first decision was when to collect these data.

Monitoring of the dispatcher's booth occurred from 7:00 am to 5:00 pm on two consecutive Wednesdays. The basis for this was two-fold:

1. As an alternative to observing the system for every day of the week, the client suggested observation of the system on the busiest day of the week. Discussion with both the morning and afternoon dispatchers revealed that Wednesday is typically their busiest day.
2. Discussion with the dispatchers indicated that most of the phone call activity occurs between 8:00 am and 3:00 pm. Additionally, examination of the driver schedule (Figure 1) showed the most vehicles on the road between 9:30-10:15 am and 2:15-4:30 pm. We decided to observe between the hours of 7:00 am and 5:00 pm in order to capture the peak period(s) of operations.

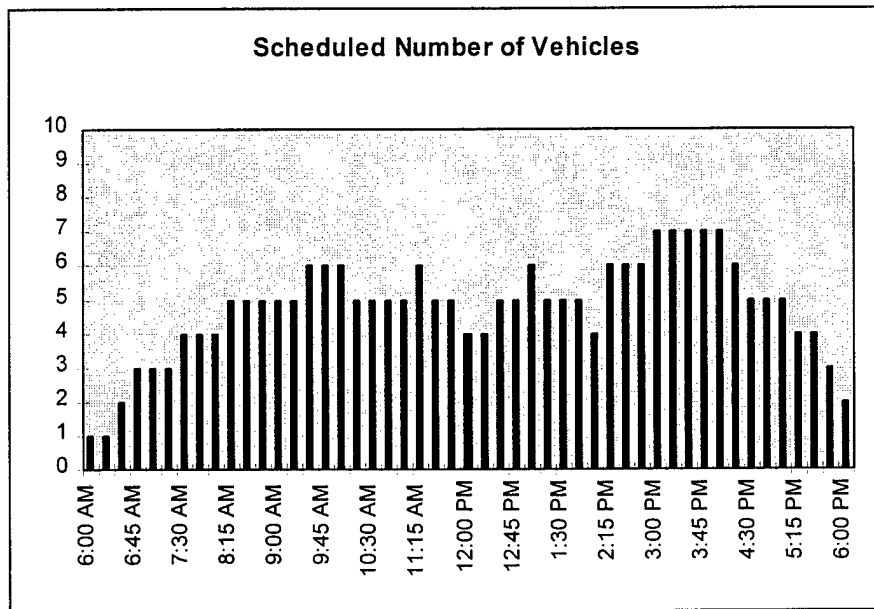

Figure 1

In the dispatcher's booth, data were collected as follows:

- The start and stop time of each call was measured.
- Phone calls that were put on hold were accounted for by recording the time placed on and off hold.
- Timing started when the phone was answered, not when it rang.
- One radio call was considered to be one incidence of information exchange between the driver and dispatcher. (In reality, this exchange may have required both the

dispatcher and driver to use the radio, but it makes sense to consider this as just one "call".)

- Once in a while, a start time or stop time was missed due to a high level of activity in the dispatcher's booth. Although the length of that particular call could not be captured, the call was still accounted for in order to get an accurate estimate of the rate of incoming calls.
- Radio calls that were conducted while the dispatcher was on the phone were marked as such in order to avoid double-counting time for the busy time estimate.

Radio calls which were not routine in the sense that they would not have been able to be transmitted by MDT (for example, asking for directions to an address) were marked as such in order to make predictions about the effects of MDT's on radio traffic.

Figures 2 and 3 show results of a compilation of the data. The raw data that were collected are not included in this report, but they can be made available to the client if desired.

2.1.1.2 Results

Hourly averages were determined for the number of incoming radio and phone calls and the durations of radio and phone calls. These averages can be found in Appendix A.

The call rate and duration averages were used to calculate the dispatcher's hourly average busy time according to the following formula, which accounts for the average hourly time spent on both the phone and radio, corrected for any "double-counting" of time the dispatcher spent on both simultaneously:

Hourly Average Busy Time =

$$\begin{aligned} & (Ave. \# \text{ Radio Calls} \times Ave. \text{ Radio Call Length}) \\ & + (Ave. \# \text{ Phone Calls} \times Ave. \text{ Phone Call Length}) \\ & - (\text{Total Time Spent on Radio and Phone Simultaneously}) \end{aligned}$$

Figure 2 lists the observed hourly and overall busy time averages. Note that the dispatcher spent over 20 minutes per hour during peak hours just on the phone and radio. This time reflects a great deal of switching back and forth between tasks, as well. Adding data entry and trip dispatching to the scenario reflects that there is, in fact, an overload on the dispatcher. The overall observed busy time was 19.4 minutes.

In order to estimate the effects of adding MDT's to the system, observed radio calls were identified to categorized as either MDT-transmittable or not MDT-transmittable. Hourly average percentages were calculated reflecting the proportion of radio traffic that would be alleviated with the addition of MDT's. These are listed in Figure 3. The overall estimated percentage of MDT-Transmittable Radio Traffic was 87%. This result is in agreement with an estimate found in Radio Resource magazine, which states "Once employees become familiar with using MDT's, voice traffic decreases by about 70-90 percent of previous use" (Vol. 9, No. 2; March 1995, p.41).

To calculate the effect on dispatcher busy time if MDT's were added to the system, this 87% estimate was used to modify the busy time formula as follows:

Hourly Average Busy Time =

$$(1-.87) \times (\text{Ave. \# Radio Calls} \times \text{Ave. Radio Call Length}) \\ + (\text{Ave. \# Phone Calls} \times \text{Ave. Phone Call Length}) \\ - (\text{Total Time Spent on Radio and Phone Simultaneously})$$

Figure 2 also includes these results. Note that MDT's would cut dispatcher busy time almost in half during peak hours. Based on this study's observations, MDT's are projected to reduce dispatcher phone and radio busy time by 43% overall.

Dispatcher Busy Time			
Time	No MDT's (Minutes)	With MDT's (Minutes)	Percent Reduction
7:00 AM	11.79	8.24	30%
8:00 AM	18.77	12.29	35%
9:00 AM	22.34	13.43	40%
10:00 AM	23.52	12.61	46%
11:00 AM	17.54	9.36	47%
12:00 PM	15.32	7.39	52%
1:00 PM	19.54	10.84	44%
2:00 PM	20.00	12.16	39%
3:00 PM	17.02	9.21	46%
4:00 PM	17.69	10.80	39%
Overall	19.41	11.02	43%

Figure 2

Mean Percentage of Radio Traffic that is MDT-Transmittable	
Hour	%
7:00-8:00 AM	91%
8:00-9:00 AM	82%
9:00-10:00 AM	93%
10:00-11:00 AM	72%
11:00 -12:00 PM	87%
12:00-1:00 PM	92%
1:00-2:00 PM	92%
2:00-3:00 PM	97%
3:00-4:00 PM	84%
4:00-5:00 PM	82%
Overall	87%

Figure 3

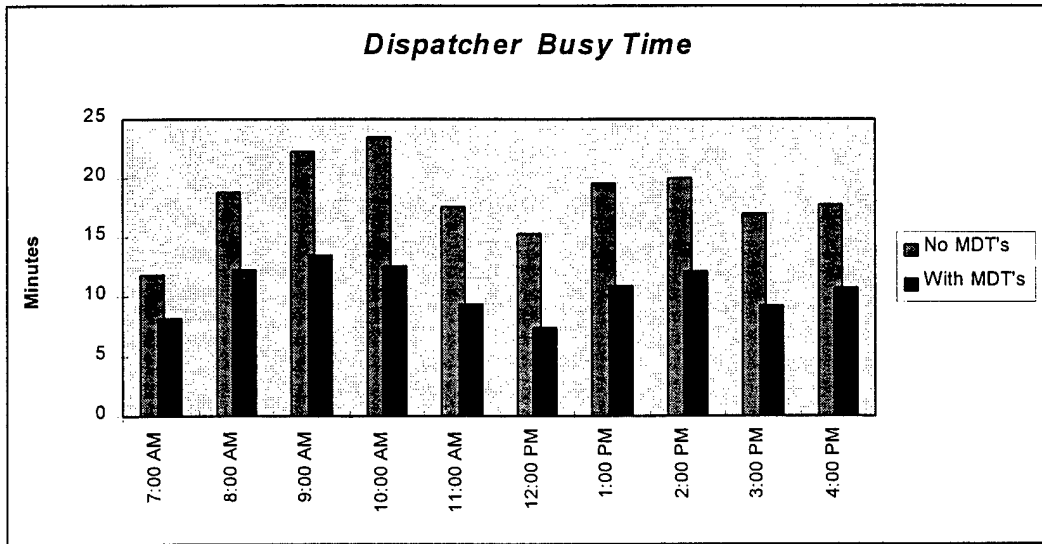

Figure 4 - Graph of Figure 2 Results

2.1.3 Trip Data Entry

Currently, when a driver picks up a customer, she calls the dispatcher to confirm that passenger "x" has been picked up at location "y". At that point, the dispatcher should note the time and mark that leg of the trip as having been completed. Upon arrival, the driver calls again to confirm passenger, location, and type of fare paid. The dispatcher enters this information again. The following aspects of this process were observed while in the dispatcher's booth:

- Marking the trip as "performed" requires scrolling to that trip followed by the keystroke <F2>. At this point, the computer time stamps the trip performance.
- Adding or changing any trip information, such as type of fare paid or arrival time, requires scrolling to that trip and opening another screen with the keystroke <P> to enter the appropriate information.
- During peak hours, it is not uncommon for the dispatcher to make a handwritten or mental note of the trip performance information. She enters it at a later time, which leaves room for error. She may have to estimate the time a trip performance occurred, or may forget altogether and have to call the driver to reconfirm the completion.

These observations show that trip data entry is time-consuming: the driver must first relay the message by voice, then the dispatcher often must make a handwritten/mental note before entering the data into the computer.

With MDT's, the driver would enter the trip performance into his terminal on the vehicle. The keystroke combination would be simple, as the MDT's we are considering have built-in function keys for standard operations such as arriving, departing, boarding, and alighting. This action on the part of the driver would replace both the radio call and the dispatcher data entry. It would

also alleviate the data entry delay, thereby providing a more accurate time stamp.

2.1.4 Repetitions and Multiple Call-Outs

Time in both the dispatcher's booth and on vans revealed that voice messages are often difficult to understand. In part, this is due to the nature of UHF radio communication. In addition, some areas of Chapel Hill have poor radio coverage, making messages especially difficult to decipher. Finally, sometimes more than one person is trying to relay information at once. All of these factors contribute to the frequent need for the dispatcher to repeat a message.

With MDT's, the dispatcher would assign trips to drivers in the Mini-PASS system. This information would be automatically sent to the MDT's, eliminating problem of repetitions on behalf of the dispatcher. It should be noted that successful data transmission is dependent on a reliable radio system. A system with poor coverage might require more than one attempt before data are transmitted successfully. Nevertheless, these repeated attempts would be made by the computer, not the dispatcher.

2.2 Driver Perspective

Vans were ridden for a total of seven hours on two different days between the hours of 8:00 am and 2:00 pm. Observations during this time showed:

- The drivers often had to radio more than once before receiving a response from the dispatcher.
- Repetition of the dispatcher's message was frequently requested.
- The vehicle was vacant and idle multiple times. At one point, a driver left his stop without knowing his next destination and had to turn the vehicle around upon receiving his next trip assignment.
- Calling the dispatcher to relay pick-up/drop-off information did not necessarily occur when the vehicle was stopped. This observation is mentioned in light of its effect on the accuracy of trip arrival and departure times.

Experiences on the van rides prompted the distribution of a survey to see how common these observations were among all drivers. The survey included a cover letter that gave a simple explanation of MDT's, questions about current operations, and questions about driver attitudes toward the idea of MDT's. It was distributed to all 16 drivers, and 13 surveys were returned. Appendix B contains the survey questionnaire and the compiled results.

The following subsections discuss the findings of this survey.

2.2.1 Multiple Attempts to Reach Dispatcher

The survey revealed that the driver often made more than one attempt to call the dispatcher before receiving response. A discussion with one of the dispatchers about why this was so showed that:

- Drivers can only hear the dispatcher, not the other drivers, from their radios. Because of this, they may be attempting to call in while unaware that another driver is talking.
- If the driver calls in while the dispatcher is talking, she will not be heard.
- Sometimes a driver may think that a conversation is finished based on what she hears from the dispatcher. She will then attempt to talk over the ongoing conversation and fail to be heard.
- If two drivers call in at the same time, both may not be heard.
- If a driver calls in during another radio or phone conversation, he may be heard, but the dispatcher may not be able to respond to him.

For these reasons, multiple call-outs are a "fact of life" in a voice radio communication system. They are a source of inefficiency, so it would be helpful to alleviate them.

Here are the responses to two driver survey questions regarding the number of call-in attempts required to reach a dispatcher:

1. I usually get a response the first time I call out to the dispatcher.

Disagree: 8 out of 13
Neutral: 1 out of 13
Agree: 4 out of 13.

The majority do not usually get a response the first time they call out to the dispatcher

2. How often do you have to call out to the dispatcher multiple times before getting a response?

50% of the time or more: 6 out of 13
25% of the time or more: 9 out of 13
Rarely: 4 out of 13

The majority make call outs 25% of the time or more.

In the section of the survey provided for comments, five drivers made reference to heavy radio traffic and/or difficulty reaching the dispatcher.

In addition to the driver survey, we developed a Continuous-Time Markov Chain model to determine the percentage of the time drivers reach the dispatcher on the first attempt. The results from this particular problem were not included in the client report because the model made several simplifying assumptions. Nevertheless, the problem is an interesting one, and it is outlined in Appendix C. Analysis of the CTMC model indicated that drivers reach the dispatcher upon first attempt less than 70% of the time. In other words, nearly one out of three calls to the dispatcher require multiple attempts in order to gain response.

These results confirm the original observation that multiple attempts to reach the dispatcher are a problem. A delay in reaching the dispatcher could cause:

- Delay in receiving next trip information
- Delay in trip execution (i.e., late arrivals)
- Inaccurate pick-up/drop-off time information
- Less attention devoted to the passenger while the driver is on the radio.

With MDT's, the issue of multiple call attempts would be eliminated. Drivers would send trip information by using a short keying sequence without having to wait for the acknowledgment of the dispatcher. Information about the driver's next trip would most likely already be on his screen, since those data are sent when the dispatcher assigns trips to vehicles. The driver would be able to leave the stop right away, increasing the likelihood of arriving to the next stop on time. Trip execution time stamps would be related to the time the driver entered the data, rather than to the time the data arrived. Finally, spending less time waiting for acknowledgment on the radio would give the driver more freedom to serve the customer.

2.2.2 Repetitions

The reasons for message repetitions were discussed in Section 2.1 from the dispatcher's perspective, and they also apply to the driver's perspective. The results from this survey question on this topic are:

How often do you have to repeat yourself or ask the dispatcher to repeat herself because a message was unclear?

50% of the time or more:	7 out of 13
25% of the time or more:	10 out of 13
Rarely:	3 out of 13

The majority of drivers have to repeat themselves 25% of the time or more.

Repetitions extend the average length of a radio call, which increases the busy time of the dispatcher and forces the driver to spend less time with the customer.

MDT's would eliminate the need for the driver to repeat messages, which would decrease dispatcher busy time and increase the amount of time available for the customer to spend with the passenger.

2.2.3 Vacant Vehicles

Van observation revealed that drivers usually knew their next destination when they reached a stop. For the most part, the dispatcher informed the driver of two or three trips at a time. However, from time to time, the driver had a vacant vehicle and had received no instruction on where to go next.

In this situation, a driver should attempt to call the dispatcher for his next trip. If he does so, he faces the multiple call-out issue. If he does not choose to call, the dispatcher will most likely be unaware of the driver's "vacant and idle" status. In both the vehicle and the dispatcher's booth, the study identified situations in which

- The idle driver called in, and the dispatcher was not aware of his status.
- The dispatcher called out to a driver who had not called in and discovered that her status was idle.

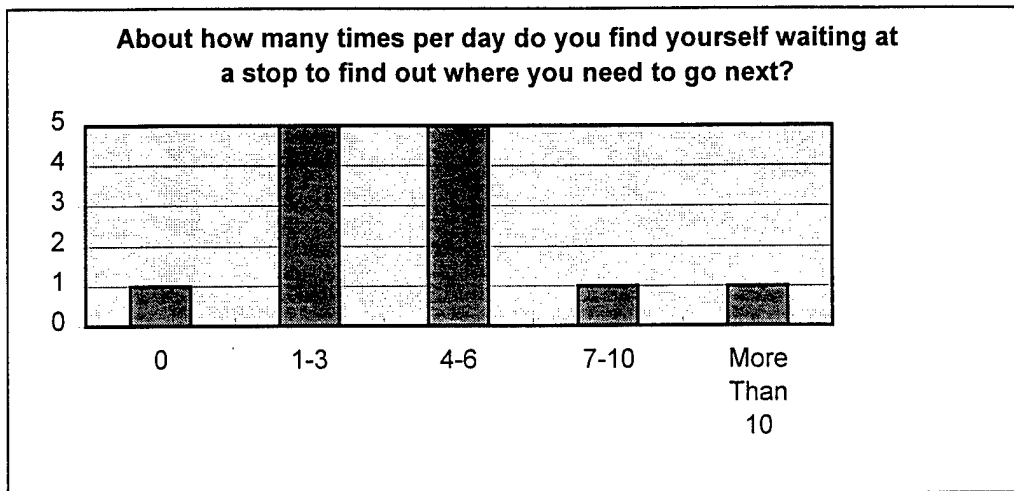

Figure 5

Figure 5 shows that the majority of drivers are idle and vacant between 1 and 6 times per day. Vacant and idle vehicles are of concern because they lead to lower average trips per hour and more late arrivals.

With MDT's in place, the driver would be aware of all trips that had been assigned to his vehicle up until that point. She would therefore be less likely to be at a stop waiting to find out where to go next. Of course, she would still have to wait if the dispatcher had not yet assigned any more trips to her vehicle.

During one van ride, the driver dropped off a customer at 1:31 pm. At 1:40 he attempted to call the dispatcher for his next trip. After receiving no response, he left his location. When the dispatcher called him at 1:44 with his next trip information, he had to turn around.

This situation prompted a driver survey question about the number of times they leave a stop under similar circumstances during the day. Twelve out of thirteen drivers indicated that they did sometimes leave a stop before knowing their next destination during the day. Among these, the indicated average number of occurrences per day was 3.2.

Leaving a stop without knowing her next destination can force the driver to turn around. This wastes time and resources. With MDT's, this could be avoided since drivers would almost always be aware of their next trip information.

2.2.4 Attitudes Toward MDT's

If CHT decides to implement an MDT system, it will be important to have the drivers' support, since they will be the MDT operators. The Minipass computer-aided dispatch system has only been in place since December of 1996, and both dispatchers and drivers are struggling to make the operational transition. In light of this, it is important for CHT

administrators to have an awareness of drivers' attitudes toward the idea of a mobile data system. A few questions in this survey sought to find out what drivers thought. Figures 6, 7, and 8 illustrate the results.

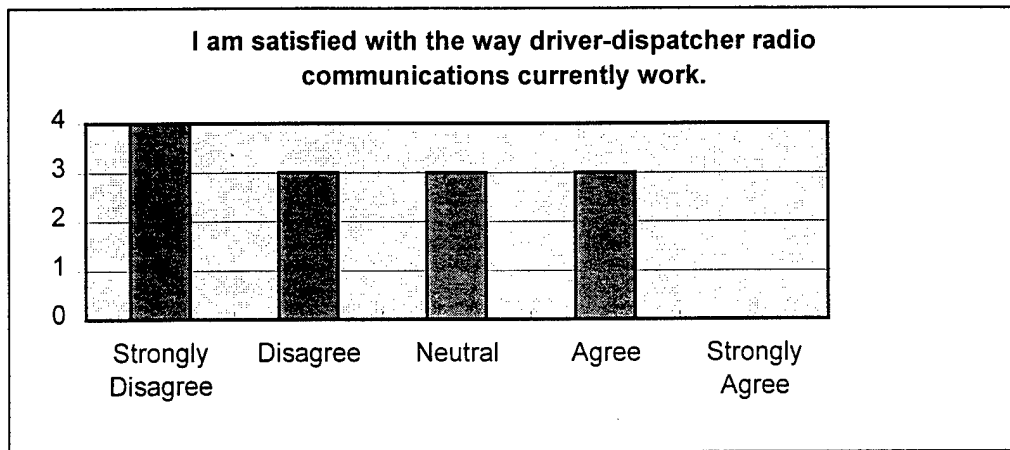

Figure 6

Figure 6 shows that 7 out of 13 people expressed some level of dissatisfaction with the current system. Results indicate that more are dissatisfied than satisfied; however, almost half are either neutral or satisfied. Although driver opinions are well-mixed on this issue, they lean more toward dissatisfaction with the way radio communications work now.

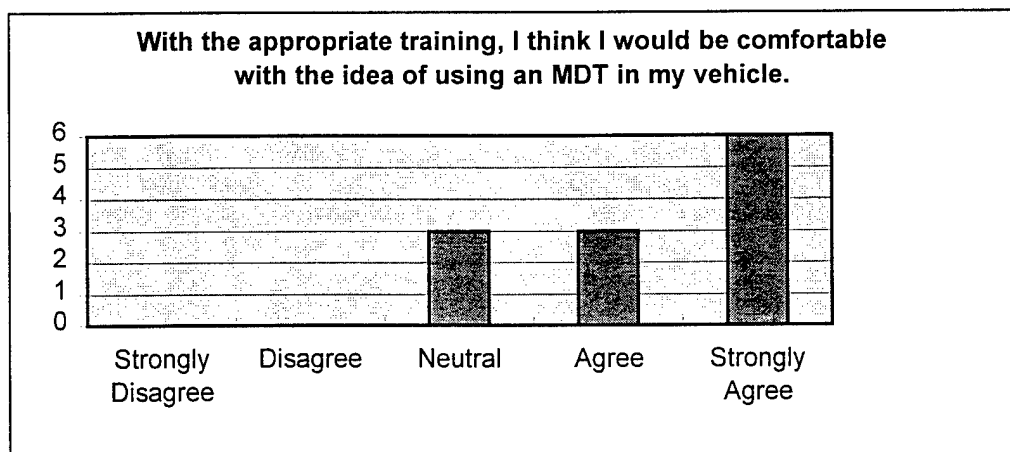

Figure 7

Figure 7 reveals that none of the drivers who responded thought that he would be uncomfortable with an MDT. Ten out of thirteen expressed some level of agreement with the statement.

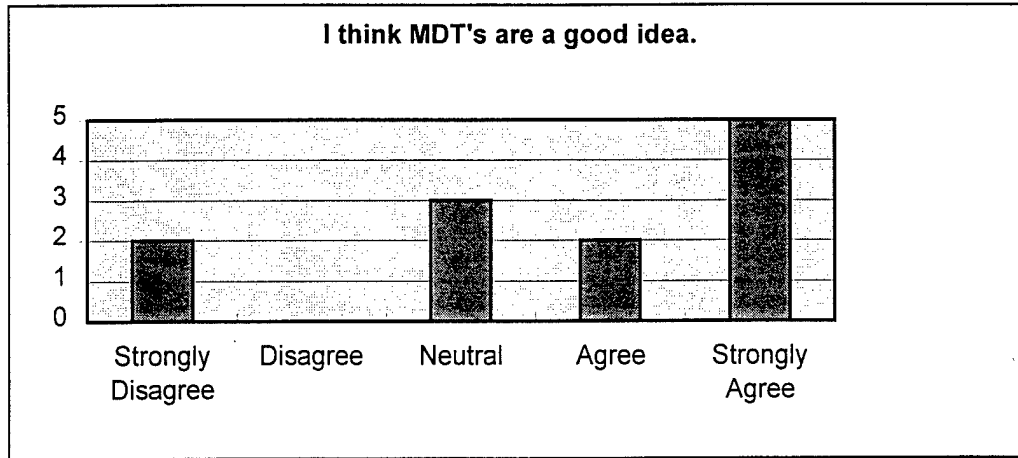

Figure 8

Figure 8 shows that this statement did not receive as much positive response from the drivers. Although 7 out of 13 still expressed their agreement with the notion of MDT's being a good idea, 2 drivers strongly disagreed. The management should be aware that these sentiments exist among some of the drivers.

In the course of this research, we spoke with representatives from several cities that have already installed similar systems. More detailed discussion of these conversations can be found in Chapter 3. Each of the cities we contacted indicated that its drivers had a favorable response to MDT's.

2.3 Reporting Perspective

City representatives we spoke with indicated that reporting capabilities were one of the most significant benefits they had experienced after acquiring MDT's. Reporting is important because it provides administrators with the tools to assess operations from several standpoints. These include cost-efficiency, customer service, and activity level.

Mr. McClellan mentioned that reporting average trip length, individual trip lengths, comparison of revenue miles vs. total miles, average trip time, individual trip times, dwell times, number of passengers per mile or hour, and on-time vs. late trip execution times were of interest to CHT. The following subsections explain how MDT's would aid in generating these reports.

2.3.1 Real-Time Credibility

If a no-show customer calls to find out why she was not picked up for her trip, the dispatcher currently explains that she was not there on her pick-up time, and that drivers are not to wait more than three minutes for a passenger.

With MDT's, the dispatcher could give the customer more specific information, such as "Mrs. Jones, our records show that van #707 arrived at 10:03 and departed at 10:06. This type of real-time reporting of trip data lends credibility to the dispatcher, allowing him to handle customer questions quickly and effectively.

2.3.2 Time and Mileage Stamping

At present, drop-offs and pick-ups are time-stamped by the Minipass CAD software when they are entered into the computer. However, this time is not an accurate representation of the actual trip execution time. The driver reports the trip by voice, and the dispatcher enters that trip completion at some point afterward. If it has been more than a few minutes, the dispatcher overrides the computer's time stamp and enters an estimated completion time. The dispatcher may have to ask the driver for an estimated completion time. Figure 9 gives a pictorial description of this process.

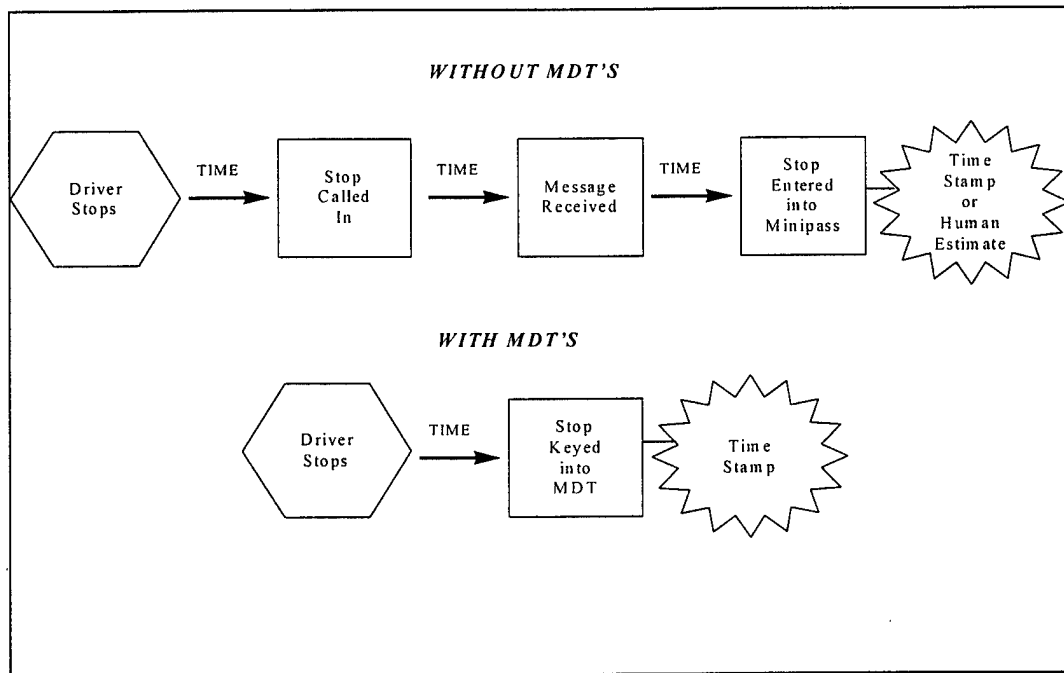

Figure 9 - Recording Trip Stop Times

This method does not provide reliable trip execution times for reporting purposes. CHT charges some customers based on time spent on the vehicle, which requires accurate trip completion time information. In addition, CHT has committed to limiting customer trips to 60 minutes when possible. Without an accurate method of tracking trip lengths, however, Chapel Hill does not have a way of measuring its performance in this area. With accurate trip length reports, CHT may even be able to commit to shorter trip lengths.

Since MDT's are accessible to the driver, they would be an excellent tool for accurate trip time information. When a driver sends a precanned message, the MDT automatically attaches the time to the other trip information. As Figure 9 demonstrates, an accurate time would only rely on the driver's prompt entry of the stop into the MDT. Time stamps on different messages such as "arrive" and

“board”, for example, would also allow for reports on dwell time (time spent at a stop before customer boards).

Mileage stamps also accompany any message that is sent by an MDT if odometer readers are included in the system. Odometer readers are a relatively inexpensive option available on both MDT's we investigated. Having an odometer reading at every stop would allow for reporting:

- Average trip length
- Average speed of the vehicle
- Total miles traveled by vehicle
- Passengers per mile.

There is currently no system in place to attempt to monitor the length of each trip. Having odometer readers on MDT's would add to CHT's reporting capabilities in this manner. It would also eliminate the need for drivers to call in their starting and ending mileage each day for the dispatchers to enter into the Minipass system manually.

2.3.3 Flexible Data Collection

MDT's have programmable function keys, and would be able to provide data collection capabilities for door cancellations, no-shows, boardings, alightings, and similar events indicated by the client. This flexibility would allow for the collection of information that would be of particular interest to CHT.

2.4 Customer Perspective

Preceding sections of Chapter 2 have provided a great deal of analysis and discussion of the possible impact of MDT's on CHT's operations. This has been approached from the dispatcher, driver, and reporting perspectives. Many of the potential gains can be viewed from another perspective – that of the customer.

Based on the findings, the customer will be affected in the following ways if MDT's are introduced:

1. Reduced dispatcher workload would provide more time for her to focus on making good choices for assignment of trips to vehicles. Better dispatching would result in more timely service.
2. Reduced radio traffic would lessen the need for dispatchers to answer radio calls while on the phone or put the customer on hold to converse with a driver. This would have the effect of shortening the time a customer stays on the phone. Shorter phone calls would also reduce the likelihood of receiving a busy signal when calling in.
3. MDT's would reduce the dispatcher's interaction with Minipass. She would only use it to dispatch and book trips. Again, this lessened dispatcher activity would allow for a more customer-oriented level of operations.
4. Reducing the time a driver must spend trying to relay a trip stop message translates into increasing his ability to focus on the customer.
5. MDT's would allow the driver to see her next trip without waiting for the dispatcher or having to turn around. This would provide more timely service for the customer.
6. Reporting that indicates average customer trip time will allow administrators to monitor performance more accurately. If customers are staying on vehicles for too long, this will be clear from trip time data, and CHT will be able to take steps to improve the situation.
7. Accurate trip time and mileage reporting will enable CHT to charge clients correctly for services rendered.

2.5 Summary

The findings included in this chapter indicate that MDT's will improve CHT's paratransit operations in a variety of ways. These include:

- Reducing the busy time of the dispatcher
- Reducing the time associated with dispatcher data entry
- Eliminating the current problems of radio call repetitions and multiple call-outs
- Eliminating the current problem of multiple driver attempts to reach the dispatcher
- Reducing the occurrence of vehicles being idle or vacant
- Improving real-time reporting credibility
- Improving reporting capabilities via time and mileage stamping
- Providing flexibility in data collection
- Improving service provided to customers calling dispatcher
- Improving service provided to passengers during their trips.

As this chapter has shown, the benefits associated with MDT's will provide good solutions to many of the problems currently observed in CHT's paratransit operations. These benefits should be weighed along with the costs explored in Chapters 3 and 4 in order for CHT to make a decision about adding this technology.

CHAPTER 3:
MDT IMPLEMENTATION

3.1 Investigation of MDT Implementation

In addition to investigating the effects of MDT's on current operations, the study included research concerning what steps CHT would need to take to implement MDT's. The information-gathering process involved interaction with many sources, including state transportation and telecommunications representatives, several sales representatives from Trapeze, and many MDT vendor representatives.

Ms. Debbie Collins, of the Institute for Transportation Research and Education (ITRE)'s Public Transportation Program, provided some initial contacts. She suggested contacting Mentor Engineering and GMSI, Inc. She also recommended talking to representatives of public transportation systems in Charlotte, NC, Winston-Salem, NC, Minneapolis, MN, and Lakeland, OH, due to their involvement with MDT's.

These initial calls led to many additional points of contact. Each conversation provided new facts about MDT implementation. An analysis of the compiled information gathered in these conversations indicated that adding an MDT system would require three actions for CHT:

- **Action 1: Acquire some type of communications network to transmit data**

Without an adequate communications network to transmit data from the vehicle to the dispatcher's computer, the MDT itself is useless. Clients, MDT vendors, and Trapeze representatives all stressed this point. A communications network must be able to handle all data transmitted from dispatcher to driver (or vice versa) efficiently if MDT's are to have a positive impact on operations.

- **Action 2: Negotiate a contract with Trapeze to interface Minipass with MDT's**

With MDT's, the dispatcher does not have to enter trip data because that information is transferred directly from the driver to the central computer. This requires communication between MDT software and the dispatching software. CHT would need to have a contract with Trapeze Software Group to handle the MDT-Minipass interface.

- **Action 3: Choose an MDT vendor and negotiate a contract with that company.**

Clearly, CHT needs to choose a company to provide its MDT's. This company should provide a high-quality product with adequate functionality at a low cost. It would also be appropriate to consider company size, background, location, and experience in paratransit operations.

Chapter 3 describes the details associated with each action. Appendix D contains phone numbers for contacts referred to in Chapters 3 and 4.

3.2 Action 1: Communications Network Acquisition

3.2.1 Four Options

Data are transmitted between MDT's and the dispatcher's central computer via a communications network. The MDT vendors that were considered have designed their products to interface with several different types of communications networks. In order to implement MDT's, CHT would need to have a reliable way of transmitting data. The four available options that we found are:

Option 1: Use current radio channel to transmit both voice and data.

CHT currently has one 450 MHz UHF radio channel, call sign KAG662, which is used for voice communication between dispatchers and fixed route and paratransit vehicles.

Although it would be possible to transmit both voice and data using KAG662, MDT vendor representatives did not recommend this approach. The reason for this recommendation was that the voice traffic generated by fixed-route vehicles, along with the small amount of paratransit voice traffic not alleviated by MDT's, would probably cause delays in data transmission.

Both Winston-Salem Transit Authority (Winston-Salem, NC) and Everett Transit (Everett, WA) confirmed this concern. Each had tried to use the same channel for voice and data, and each experienced significant transmission delays that negatively affected operations. Both were forced to seek other communications alternatives after their MDT systems were operational.

Option 2: Gain another UHF channel, and designate it to transmit data only.

Consultation with Mr. Dyke Hostettler, NC State Frequency Coordinator, confirmed that CHT would be able to acquire a second UHF channel. This would allow, CHT to use one channel for voice and the other for data in order to facilitate quick message transmission. Since the cost associated with this action is low compared with other alternatives, this would be of great benefit to CHT. Although UHF channels are limited, Mr. Hostettler conducted a frequency search which indicated that the frequency 452.7 MHz would be available to CHT. Appendix E contains the search information.

The cost associated with acquiring a second UHF channel would be minimal. According to Mr. Hostettler, a one-time FCC license fee would be under \$300. Mobile radio equipment could be used to switch from one channel to another. This would involve changing from hand-held to mobile radios in paratransit vehicles. Alternatively, CHT may prefer to have two radios in each vehicle in order to allow for continued data

transmission even while the voice channel is being used. Three comments on the driver survey also indicated that they like using hand-held units for voice radio.

Option 3: Use a state-supported 800 MHz mobile data trunked radio system.

A trunked radio system is large mobile data infrastructure which allows several subscribers to transmit large amounts of data very quickly. The system is managed by very fast switching equipment. This option would require CHT to purchase a \$2200 modem for each vehicle.

The trunked network is designed to send large and complex amounts of information, such as criminal records for the North Carolina State Highway Patrol. Mr. Hostettler, who is also the coordinator for this system, indicated that a second UHF channel would be more appropriate and cost-effective for CHT.

Option 4: Use cellular digital packet data (CDPD) technology.

CDPD allows data packets to be transmitted over idle portions of a cellular voice network. It could be provided by standard cellular providers. It would require a CDPD modem device for each vehicle, a host-end message router, and would involve monthly charges based on amount of data transmitted.

3.2.2 Recommendations for Accomplishing Action 1

Agreement among current clients, MDT vendors, and Trapeze indicates that attempting to put both voice and data on one channel would be unwise. The options of using a trunked radio system or CDPD are significantly more costly than simply acquiring a second UHF channel. Since a second channel is available, the recommended option is to acquire it and designate it specifically for data transmission.

If CHT decides to add MDT's, we recommend that it first acquire this channel. UHF frequencies are limited, and continued availability cannot be guaranteed.

A second radio channel could be accommodated by switching back and forth on current radios or by putting two radios on each vehicle. MDT vendors will usually conduct a radio evaluation to help the client decide how to configure radios in its vehicles. Mr. Dean Richardson, regional sales representative from Trapeze, also suggested that CHT consider inviting an independent radio consultant to evaluate the adequacy of its current system before MDT implementation. He suggested that this initial investment could save CHT in the long run. Mr. Richardson recommended Larry Sparks, of Sparcoms Corporation in Cincinnati, Ohio. Mr. Sparks is serving as the radio consultant for Winston-Salem Transit Authority.

3.3 Action 2: Contract with Trapeze

3.3.1 Three Issues

A contract with Trapeze is necessary to achieve the needed interface between Minipass and the MDT software. This contract would cover the license for the interface itself, engineering, and travel expenses. Three issues arise when considering this contract.

Issue 1: This contract requires CHT to use Minipass CAD software.

The cost to interface is about half of the total cost of adding MDT's, which implies that adding MDT's requires a financial commitment to the Minipass, as well. If CHT ever decides to change to new dispatching software, a new MDT interface contract would be required. CHT should recognize its long-run commitment to the use of Minipass if it decides to make an interface contract with Trapeze.

Issue 2: CHT would be the first system to interface MDT's with Minipass.

Several cities have interfaced MDT's with Pass, another CAD software package made by Trapeze. Since Minipass is essentially Pass with several options switched off, Mr. Don Christianson, MDT Project Manager for Trapeze, indicated that the Minipass-MDT interface engineering would be similar to that of Pass. Appendix F contains the details of this option.

On the other hand, Mr. Tom Juhnke of South West Metro Transit (Minneapolis, MN) indicated significant concern about CHT being the first to have this type of interface. South West Metro Tran was the first to have a Pass-MDT interface, and experienced a great deal of initial difficulty. He suggested that a contract with Trapeze include a commitment for an on-site representative for an extended period of time until the system is running smoothly.

Issue 3: A Minipass-MDT interface contract would rule out the possibility of Automated Vehicle Locator Technology.

Originally, CHT was interested in the possibility of including Global Positioning System/Automated Vehicle Locator technology in a mobile data system. However, Minipass does not allow for this, since it has no mapping capability. If CHT desires AVL capability, it should upgrade to Pass CAD software (or another comparable package) before pursuing an MDT interface contract.

3.3.2 Contract Costs

Mr. Robert Dukes, Vice President of Sales at Trapeze, provided a cost estimate of an MDT interface contract between CHT and Trapeze. The cost breakdown is listed here.

• Interface license fee:	\$10,000
• 20-23 days of in-house and on-site engineering:	\$17,000
• Airfare and travel expenses:	\$ 5,000
• After first year, annual maintenance fee:	\$ 2,000
Total initial cost:	\$32,000
Total annual maintenance cost:	\$ 2,000

3.3.3 Recommendations for Accomplishing Action 2:

CHT should maintain contact with Mr. Rob Dukes and Mr. Dean Richardson, Trapeze sales representative for North Carolina, to negotiate these costs. Additionally, CHT should consider the three issues presented in Section 3.3.1 before pursuing a contract with Trapeze.

3.4 Action 3: Choosing an MDT Vendor

The third part of implementing an MDT system is choosing the MDT vendor. Consideration must be given to the company background, location, and experience, as well as product functionality and costs. Costs are associated with:

1. MDT hardware – includes the unit itself, odometer reader, vehicle mount, cabling.
2. Host-End needs – includes system software, radio modem for host computer, and a PC where MDT software will be installed.
3. Engineering costs – includes on-site and in-house engineering and travel expenses.
4. Service agreements – includes initial warranty, extended warranty, and on-going maintenance and support.

Due to the amount of information and level of detail involved in making this decision, discussion of Action 3 is covered in a separate chapter. Chapter 4 investigates and compares MDT vendors, revealing that Mentor Engineering is the strongest choice for CHT. It includes detailed cost information, as well.

3.5 Summary

Chapter 3 determined three actions which CHT would need to take in order to add MDT's to its system. The recommendations for accomplishing each of these actions as discussed here are:

Action 1: Take early action to acquire a second UHF channel to be used only for data transmission. Consider using a radio consultant to help determine the best way to use radio equipment for these two channels in the vehicles.

Action 2: Negotiate an MDT Minipass interface contract with Trapeze with an understanding of the three issues presented in Section 3.2.1. Maintain contact with Mr. Rob Dukes and Mr. Dean Richardson to do this.

Action 3: Choose Mentor Engineering as the MDT vendor. More detailed recommendations for this action can be found in Chapter 4.

If Mentor were selected, the total initial cost of MDT implementation as described here would be about \$66,500, followed by costs of about \$4,500 per year for maintenance and upgrades. This estimate does not include radio consultant or additional radio hardware costs.

CHAPTER 4:
MDT VENDORS

4.1 How Vendors Were Considered

If CHT chooses to implement this mobile data system, it will need to choose an MDT vendor. This study investigated several transportation technology and mobile data communications companies. Information reflected here comes from multiple phone surveys of company sales representatives and client system representatives, along with product information and written correspondence.

In addition to the cost of the product, there were other factors which needed to be considered in choosing an MDT vendor. These included the company's background, its experience with mobile data communications in a paratransit context, and its experience working with Trapeze products. Clients who had systems similar to that of CHT were asked about their choice and their overall satisfaction with the product.

Sections 4.2 and 4.3 deal with GMSI and Mentor Engineering, two companies with products that would suit the needs of CHT. Each section addresses the company in terms of background, experience, product, and clients. Section 4.4 lists other companies which were considered. Section 4.5 summarizes reasons for the vendor recommendation offered here.

4.2 GMSI, Inc.

4.2.1 About the Company

GMSI, Inc. is a mobile data communications company and systems integrator. It has been installing systems for eighteen years, and has 55 sites established worldwide in Canada, the U.S., the U.K., Europe, Asia, Australia, and South America. Among these sites, there are 25,000 MDT's up and running. It has experience with systems in the taxi, courier, service, trucking, emergency service, transit, and paratransit industries. GMSI's parent company, Geotek, is a wireless communications service provider.

GMSI has sixty-five employees and six offices worldwide, the closest of which is Fort Myers, FL. The sales representative we worked with was Mr. Greg Davis.

4.2.2 Experience in Paratransit Operations

GMSI has a great deal of experience in the taxi industry, which has many parallels with the demand-responsive aspects of the paratransit industry. However, the company has only recently begun to implement systems for paratransit operations. It currently has five contracts with paratransit operations, two of which are up and running. These two are with Winston-Salem Transit Authority (Winston-Salem, NC) and the Potomac and Rapahonic Transit Commission (PRTC; near Washington, DC).

Since the system at the Winston-Salem Transit Authority was part of a test program, MDT's were placed on only three vehicles. They are interfaced with Trapeze's Pass CAD software. Winston-Salem has just signed a contract to put MDT's on the remainder of its vehicles.

At PRTC, MDT's are installed and working, but they are not currently being used. This is due to a delay in Trapeze's implementation of a new Windows-based CAD system.

Only three of GMSI's MDT's are currently operating in a paratransit context with Trapeze software interface. Several more are under contract, but it is clear that GMSI's primary experience is not in the paratransit industry.

4.2.3 The Product

The GMSI product for CHT to consider is the Paratransit Vehicle Information System (PVIS). PVIS provides integration with CAD software, MDT's, and the radio system. PVIS is a *multitasking* system – i.e., it can send different messages from the central computer to several vehicles at one time. Essentially, GMSI would provide a system that:

- Communicates with Minipass to gain dispatching information and update trip performance information
- Communicates with vehicle MDT's via radio to send upcoming trip information and to collect trip performance data
- Produces management reports.

GMSI's mobile data terminal is called MDT 4100 Series - Status II. The MDT's specifications are included on the following page. Appendix G includes a detailed description of the MDT requirements taken from a sample Request for Proposal from GMSI. Important aspects of the MDT are:

- The display and keypad are integrated into an L-shaped unit.
- The display is back lit, has full character-set capability including bold, underlined, double-height, and blinking characters, and has six forty-character lines.
- The keypad is back lit, has hard-coded (programmed by vendor) and soft-coded (menu-driven) keys, and a numeric keypad.
- The MDT is capable of collecting data associated with driver log-on, log-off, site arrival, site departure, rider boarding, rider alighting, rider call-out, rider no-show, door cancellation, and fares paid.
- The MDT sends data at 4800 baud, has a 32-bit processor, and has 128K of RAM.

4.2.4 Paratransit Clients

Both of GMSI's operational clients were surveyed. Although PRTC mentioned a sometimes slow reaction to customization issues and Winston-Salem has had trouble with the Pass-MDT interface, discussions revealed a generally positive reaction to the company and its product. The following page summarizes conversations with representatives from these two systems.

Figure 10 - Summary of Conversations with Two GMSI Clients

	Winston-Salem	PRTC
Contact	Suzanne Tellechea, 910-727-2648	Erik Marks, 703-643-0239
No. Paratransit Vehicles	3 with MDT's, 22 total	22 route-deviation vehicles
How long has system been in?	Have signed contract to add MDT's to rest of fleet 1 ½ years	MDT's have been functional since October, Whole system will be running in June
Why did you choose GMSI?	Were looking for a "whole package", including CAD software, Smart Cards, Automated Vehicle Locators, and MDT's. Responses to RFP's came in package form; they chose a response from On-Line (now Trapeze) for Pass CAD software and GMSI Smart Cards, AVL, and MDT's.	As part of an Intelligent Transportation Systems project, they had a team to put a "whole package" proposal together to federal government. One team member introduced team to GMSI, who introduced PRTC to Trapeze. No formal solicitation for MDT's was ever made.
Are you pleased with GMSI?	Yes, in general. There were some initial problems with odometer readers not working, but GMSI's responsiveness has been good.	Experience has been pretty good. GMSI has been slow at times to take action on customization issues, but it is improving.
What kind of contract do you have?	Primary contract is with Trapeze; subcontract is with GMSI.	Two separate contracts with GMSI and Trapeze, but Trapeze takes the lead as the "software coordinator". A technical management firm is overseeing the whole project
What benefits have you experienced from MDT's?	<ul style="list-style-type: none"> • Clerical savings (drivers were writing trip information.) • Drivers have been quite pleased. • Improved customer service and safety issues, since drivers can focus more on passenger. 	N/A - System isn't running yet.
What have been the drawbacks of MDT's?	<ul style="list-style-type: none"> • Problems interfacing – MDT's are not hard to fix if they go down, but it is hard to get the interface running again if it goes down. • Be careful about radio system – one channel couldn't handle both data and voice – had to rent space on a trunked radio system, which was slow. • Group drop-offs and pick-ups are time consuming, since each one takes a few seconds.. 	N/A

4.2.5 Contract Costs

Mr. Davis initially quoted system costs over the telephone. In order to confirm a correct estimate, costs were summarized in the following spreadsheet. This was then confirmed and edited by Mr. Davis, and he indicated that these reflected all costs that would be involved in a GMSI contract.

Total initial cost: \$47,170

Total additional annual cost: \$2,902

Figure 11 on the following page contains a breakdown of the system costs for GMSI's products. Costs are broken down into vehicle hardware, host-end needs, labor, initial service agreement, and annual service/maintenance costs.

GMSI MDT System Cost Breakdown for CHT		
Vehicle Hardware	Per Unit	Total
MDT Cost	\$1,200	\$9,600
Odometer Readers	\$100	\$800
MDT Mounts	\$35	\$280
Driver Manuals	\$4	\$80
Shipping and Duty		\$750
Total		\$11,510

Host-End Needs	
MDT Software	\$4,000
MDT Startup Program	\$560
Radio Modem for Host Computer	\$1,500
PC -- MDT Server	\$2,500
Total	\$6,060

Labor	Per Day	Total
In-House Engineering (20 Days)	\$500	\$10,000
On-Site Engineering (18 Days)	\$500	\$9,000
Travel/Living Expenses (18 Days)	\$350	\$6,300
Misc.		\$3,000
Total		\$28,300

Service Agreements	
1-yr. warranty	\$800
Modem for repairs	\$500
Buy 5% Overages	\$1,200
Total	\$1,300

Grand Total	\$47,170
--------------------	-----------------

Service Agreements - Annual	Per Unit	Total
MDT Maintenance	\$100	\$802
24-hr. Service		\$2,100
Yearly Service Total		\$2,902

Figure 11

4.3 Mentor Engineering

4.3.1 About the Company

Mentor Engineering is a Mobile Data Solutions company which has been implementing mobile data systems for eight years. It is smaller than GMSI, with only 20 employees and one office. It currently has installed over 50 systems worldwide in the U.S., Canada, and Mexico. Mentor has experience in the paratransit, oil/gas production, limousine, taxi, newspaper distribution, towing, rock quarry, utility, transit, and delivery vehicle industries.

Mentor is based in Calgary, Alberta, Canada. All sales, engineering, and warranty repair efforts are conducted from this office. We worked with Mr. Brent Freer, a sales representative there.

4.3.2 Experience in Paratransit Operations

Mentor currently has 9 paratransit operations up and running. It has contracts underway with 3 more. Of these, 5 have fewer than twenty vehicles and 8 are interfaced with Trapeze dispatching software. Contacts and system descriptions were provided by Mentor and are included in Appendix H.

Mentor's experience with paratransit operations is broad, considering the newness of the field. One of its clients, South West Metro Tran, has had MDT's on its 22-vehicle fleet for 2 years. This experience will be beneficial to CHT if it decides to work with this vendor.

4.3.3 The Product

Mentor's product is called the Express Plus Mobile Data System. Its primary feature is the Express Plus Mobile Data Terminal. It also includes XGate software, which:

- Communicates with Minipass to gain dispatching information and update trip performance information
- Communicates with vehicle MDT's via radio to send upcoming trip information and to collect trip performance data
- And produces management reports.

This product is quite comparable to GMSI's product. The Express Plus MDT has the following characteristics:

- The display and keypad are integrated into small rectangular unit.
- The display is transreflective (for bright sunlight viewing) and back lit, has full character-set capability, and has four forty-character lines.

- The membrane keypad has no moving parts, is back lit, has hard-coded (programmed by vendor) and soft-coded (menu-driven) keys, and a numeric keypad.
- The MDT has LED indicators for messages and to indicate radio channel quality.
- The MDT is capable of collecting data associated with driver log-on, log-off, site arrival, site departure, rider boarding, rider alighting, rider call-out, rider no-show, door cancellation, and fares paid.
- The MDT sends data at 1200 baud, has an 8-bit processor, and has 32K of RAM.

Mr. Freer indicated that the best feature of this MDT is its functional flexibility. Mentor is interested in provided a custom fit to CHT's MDT needs. For example, Mr. Freer said that engineers would be able to program the MDT to capture driver switches on the same run.

Appendix I contains technical specifications for the Express Plus System provided by Mentor.

4.3.4 Paratransit Clients

Discussions with some of Mentor's clients revealed an overall positive reaction to the company and its product. Three small paratransit systems, all with Pass dispatching software, were surveyed. Also, Charlotte, NC's system was contacted regarding its recent contract with Mentor.

The following pages summarize conversations with four of Mentor's client systems.

Figure 12 - Summary of Conversations with Four Mentor Clients (Part 1)

	Everett Transit - Everett, WA	Anoka Transit - Anoka, MN
Contact	George Baxter, (206) 259-8803	Tom Kineer, (612) 717-9447
No. Paratransit Vehicles	12	22 route-deviation vehicles
How long has system been in?	1 ½ years	MDT's have been functional since October; Whole system will be running in June.
Why did you choose Mentor?	Contracted with On-Line Data (now Trapeze), and Mentor was its subcontractor. On-Line Data won the contract primarily because its MDT vendor costs were significantly lower than other bidders.	SWMT (also in Minnesota) had chosen Mentor 1 year earlier; this was the basis of Anoka's choice.
Are you pleased with Mentor?	Yes; although ET doesn't deal directly with Mentor much, it has been very helpful in helping to resolve problems associated with transition from one type of network to another.	Yes - have had minimal MDT problems.
What kind of contract do you have?	Primary contract with Trapeze; sub-contract with Mentor.	Trapeze has primary contract; contact with Mentor has been minimal - 1 or 2 times.
What benefits have you experienced from MDT's?	Powerful reporting capabilities that were not available before, especially with such a small operation and staff. Drivers have been quite pleased, although they were apprehensive at first.	Able to locate drivers from one stop to the next; credible real-time reporting if a customer calls requesting trip information. Can switch trip assignments if needed. Most drivers feel good about MDT's. Dispatchers like being able to keep up with operations more easily. Less voice activity makes a quieter work environment for dispatcher & driver.
What have been the drawbacks of MDT's?	There has been trouble with group trip performances. They are slow, but Trapeze has been very helpful in working this out. Initially MDT's on shared voice radio frequency, but this was problematic; in process of changing to trunked system.	Some (1-2) drivers have found MDT to be a distraction. Sometimes the MDT's small screen can cause surprises if the driver doesn't scroll to see the next few trips periodically. Initial bug—hardware was getting overloaded. MDT's would sometimes shut down for no reason. Problem has been addressed.

Figure 13 - Summary of Conversations with Two Mentor Clients (Part 2)

	South West Metro Transit - Minneapolis, MN	Special Transportation Services - Charlotte, NC
Contact	Tom Juhnke, (612) 934-7928	Jeff McClellan, (704) 336 6103
No. Paratransit Vehicles	22	58
How long has system been in?	2 years	Not running yet
Why did you choose Mentor?	At the time SWMT was looking for a vendor, Mentor was the only one that offered an MDT that allowed for trip insertions and multiple trips on a screen.	Both Mentor and GMSI put in bids, and Mentor's was lower. Also, Mentor has a good track record for working with Trapeze.
Are you pleased with Mentor?	Yes, have had nothing but a great response from the company.	N/A system not yet installed or running.
What kind of contract do you have?	Mentor was contracted through Johnson Radio, who installed MDT's; SWMT has a separate contract with Trapeze.	Trapeze has primary contract; Mentor signed with Trapeze to make it in charge of procurement.
What benefits have you experienced from MDT's?	Real-time performance without radio chatter Just starting to see improvements; MDT's have been working better and better the longer SWMT has had them. Drivers love them.	N/A
What have been the drawbacks of MDT's?	Problems interfacing, since SWMT was the first to interface Pass with MDT's. Difficulties upgrading Pass software, had to make sure it would work with MDT's.	N/A

4.3.5 Contract Costs

Mentor provided a system quote that is included in Appendix J. In order to more easily compare this quote with GMSI's costs, the information was reorganized into a cost spreadsheet similar to that presented for GMSI in section 4.1.5. The total contract costs are significantly lower for Mentor than GMSI. The largest portion of this difference can be accounted for in engineering costs. Mentor will be able to implement the same system with about \$10,000 less in engineering costs.

Total initial cost: \$34,034

Total additional annual cost: \$2,495

Figure 14 on the following page contains a breakdown of the system costs for Mentor's products. Costs are broken down into vehicle hardware, host-end needs, labor, initial service agreement, and annual service/maintenance costs.

Mentor MDT System Cost Breakdown for CHT		
Vehicle Hardware	Per Unit	Total
MDT Cost	\$1,200	\$9,600
Odometer Readers	\$89	\$712
MDT Mounts	\$65	\$520
Cabling for MDT's	\$69	\$552
Total		\$11,384

Host-End Needs		
Xgate PC (Preconfigured)		\$3,950
Xgate Software License		\$1,400
2 Master Communications Controllers	\$1,895	\$3,790
MCC Install Kit		\$150
Total		\$9,290

Labor	Per Day	Total
On-site engineering (2 Weeks)		\$10,000
1-2 hrs. installation per vehicle	\$320	\$1,600
Total		\$11,600

Service Agreements	Per Unit	Total
5-year MDT Warranty	\$220	\$1,760
Total		\$1,760

Grand Total		\$34,034
--------------------	--	-----------------

Service Agreements - Annual	
XGate Maintenance	\$2,495
Yearly Service Total	\$2,495

Figure 14

4.4 Other Companies

The study considered other transportation management and mobile data companies. They are listed here.

1. IRD - Teleride, Inc.

- Division of International Road Dynamics, Inc.
- Sales Representative: Raymond Glenn

IRD Teleride is a Fleet Management and Transit Systems company. Its product, TransView 3.2, takes a “turnkey” approach to paratransit fleet management. It features CAD software, an automated voice answering system, MDT’s and Global Positioning System (GPS) capabilities. The system is Windows-NT based, and it relies upon CDPD communications. There are two up and running in Canada. Eight more contracts have been signed, two of which are in the U.S.

IRD’s MDT is only one aspect of its whole system. The MDT itself is simple – it has no numeric keypad, and no programmable function keys. Its hard-coded pick-up, drop-off, and no-show functions. The TransView brochure explains that the system is capable of interfacing with other MDT’s. Mentor’s Express Plus MDT is the only one of these mentioned in this context.

IRD’s primary product is not the MDT, but the company does seem to have a good turnkey product. This company would be a good option if CHT were starting from scratch. Since CHT already has CAD software and is looking for a high-quality MDT to augment this system, IRD is not a good choice.

2. Transportation Management Solutions, Inc.

- Subsidiary of Raytheon E-Systems, in Linthicum, MD
- Sales Representative: Mark Krueger

TMS is a large supplier and integrator of products for fleet management. Its product, Fleet-Trac, is marketed as a CAD/Automated Vehicle Location (AVL) system. (AVL uses global positioning technology to track the location of vehicles.) This system involves MDT’s, but TMS does not actually produce them. In fact, the company uses Mentor’s Express Plus MDT for this aspect of the system.

TMS does not offer an MDT product to be compared with the others presented here. Since CHT already has Minipass for its CAD system, the type of “whole package” product TMS offers is not what CHT needs.

3. Echelon Industries, Inc.

Initial contact with this systems integration company and conversation with its president indicated that development of a product appropriate for CHT would not be cost-effective. Echelon specializes in a turnkey data-collection system that costs about \$10,000 per vehicle for fleets over 100. Trying to adapt this system to a small fleet would not be cost-effective, and Echelon doesn't specialize in MDT's.

4. Navigational Data Systems, Inc.

Initial contact with this company indicated that although it produced MDT's, its product did not interface with Trapeze's Pass or Minipass CAD systems. It would not be cost-effective for NDS to develop this interface. The company did not indicate interest in working with CHT for this reason.

4.5 Summary of Findings

Chapter 4 has addressed the issue of choosing an MDT vendor. GMSI and Mentor were the two companies that emerged because they offered a product appropriate for CHT's needs. Here, the findings presented in Sections 4.1, 4.2, and 4.3 will be summarized in terms of positive and negative aspects of both companies. The summary table (Figure 15) can be found on the following page.

The table shows that GMSI has a bigger company with local representation. Its product transmits data and processes messages more quickly than Mentor's, but this benefit is not significant for a system as small as CHT's. Mentor outranks GMSI in cost and experience, and offers a product recognized by other transportation companies for its high quality and flexible functionality.

We recommend that CHT choose Mentor Engineering over GMSI, Inc. because of its cost, Mentor's paratransit experience, and client feedback.

Figure 15 - GMSI vs. Mentor

Aspect	GMSI, Inc.	Mentor Engineering	Better Option?
Location	Sales representative in Ft. Myers, FL; Engineers in Ontario, Canada	Based in Alberta, Canada	Either
Company Size	65 people; 6 locations	20 people, One location	GMSI
Experience with Paratransit Systems	Has little experience with paratransit systems and/or interfacing with Trapeze CAD software	Has 12 paratransit system contracts, with 9 currently running 8 of these are interfaced with Trapeze's Pass CAD software.	Mentor
MDT Capabilities	Sends data at 4800 baud Has 32-bit processor Has 128K of memory	Sends data at 1200 baud Has 8-bit processor Has 32K of memory	Either – (small fleet)
MDT Display Features	6-line, 40 character screen Flashing characters indicate message arrival	4-line, 40 character screen LED indicator lights signal message arrivals and radio quality	GMSI Mentor
Client Feedback	Winston-Salem: pleased overall; difficulties with Pass/MDT interface PRTC: pleased overall; sometimes slow in responsiveness to customization issues	SWMT: have not experienced a hardware failure; Mentor has been very responsive Anoka: have had minimal MDT problems Everett: Pleased with product; found Mentor to be helpful in solving problems	Mentor
Recognition by Other Companies		Chosen by TMS to be part of its Fleet-Trac system. Uniquely recognized by IRD as a good option for its TransView system	Mentor
Costs	Total initial cost: \$46,470 Total added annual cost: \$2,902	Total initial cost: \$34,034 Total added annual cost: \$2,495	Mentor

CHAPTER 5:
RECOMMENDATIONS

Based upon these findings, we recommend:

- 1) **CHT should consider MDT's as a good option to improve current paratransit operations in these ways:**
 - **reduced dispatcher workload, allowing more time for better dispatching decisions and caller service**
 - **faster, clearer, and less error-prone driver/dispatcher communication**
 - **more on-time trips**
 - **trip time and mileage reporting capabilities**

Investigation of the possibility of putting MDT's on CHT's paratransit system has shown that they have potential to improve operations in many ways. CHT should seriously consider adding MDT's to its fleet, especially if \$67,000 is a reasonable amount to spend and if it has committed to long-term use of Minipass or some other dispatching software.

- 2) **CHT should decide whether it will make a long-term commitment to using Minipass. If so, it will be in a position to begin the process of installing MDT's. If not, CHT will need to do further research to commit to another dispatching software package before installing an MDT system.**

Contracting to interface MDT's with scheduling software makes up about half of the total cost to install MDT's. This money will be well spent only if this interface is usable for the long term.

If CHT decides to implement MDT's, we also recommend:

- 1) **CHT should pursue Mentor Engineering as the best vendor option for this system. Mr. Brent Freer, the sales representative we worked with during the study, is the point of contact. CHT should arrange for a visit and presentation from the company.**

GMSI offers a high-quality product, but any gains over Mentor from its higher speed and larger memory would only be seen in large systems. Mentor has more paratransit experience, more experience working with Trapeze, and favorable response from its clients and other companies in the field. Combined with its significantly lower system cost, these reasons make Mentor a better choice for CHT.

- 2) **CHT should take early steps to gain the second radio frequency needed for the MDT system. Mr. Dyke Hostettler, State Frequency Coordinator for North Carolina, is the point of contact. It should also contact a radio consultant, possibly Mr. Larry Sparks, to consider the possibility of using his**

services to ensure an adequate radio system.

- 3) **CHT should begin to work toward a contract with Trapeze Software Group for the MDT - Minipass interface. The point of contact is Mr. Dean Richardson. The contract should contain a commitment from Trapeze to staying until the interface is running smoothly, since CHT would be the first Minipass-MDT interface site.**

APPENDIX A:
PHONE AND RADIO ACTIVITY RESULTS

Data collection for the dispatcher busy time analysis required monitoring rate of call arrivals and duration of calls for both the phone and the radio. Results for average call length and duration for phone and radio were compiled and are presented here.

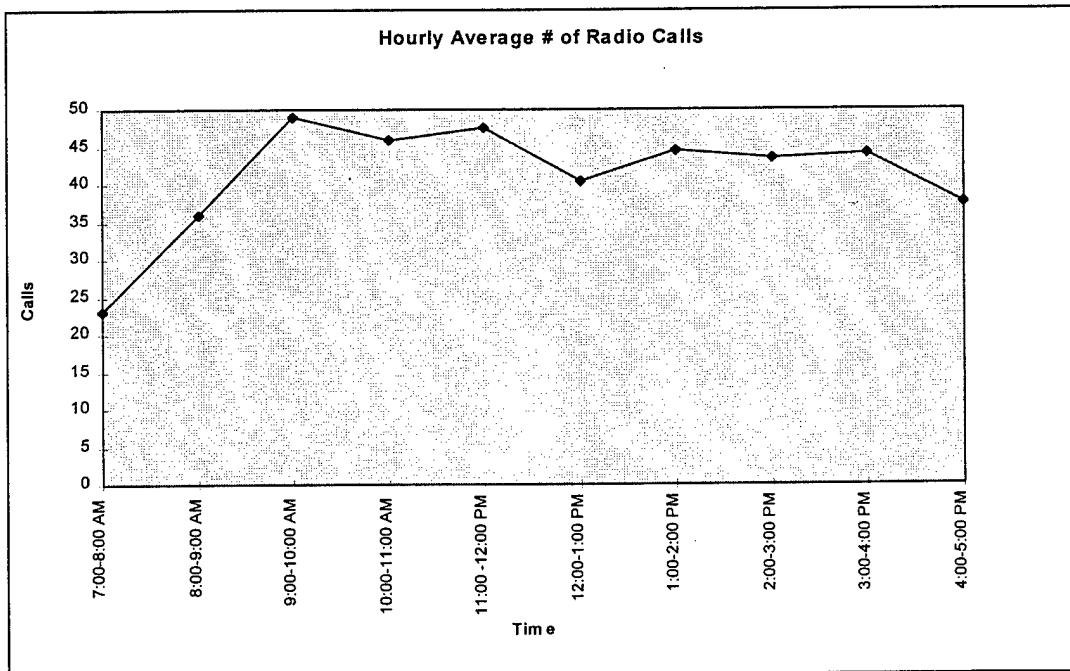
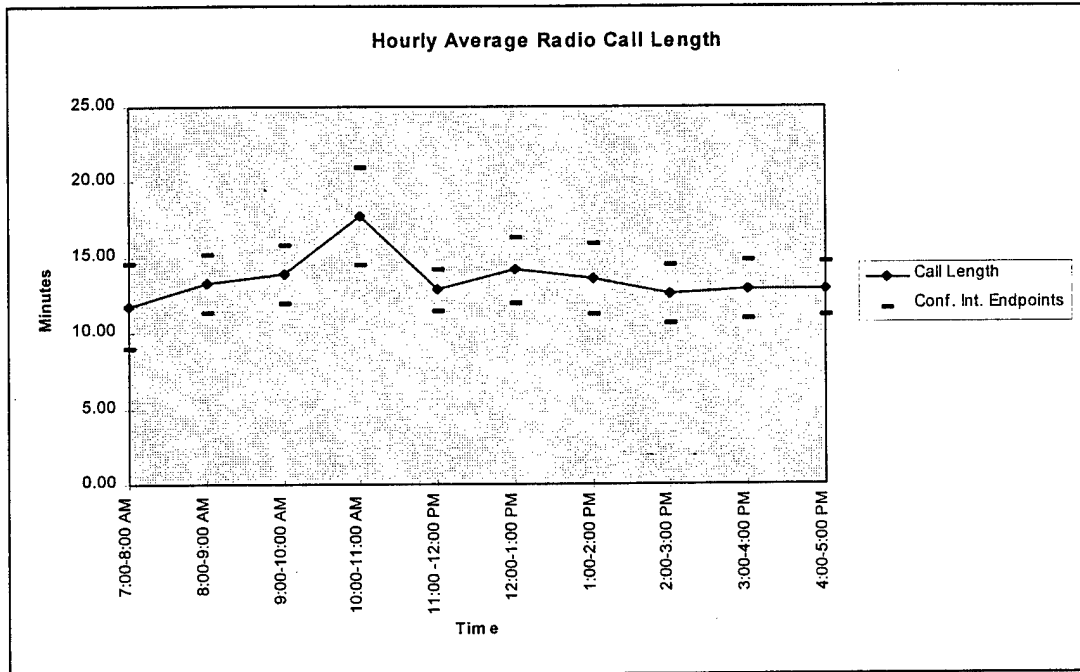

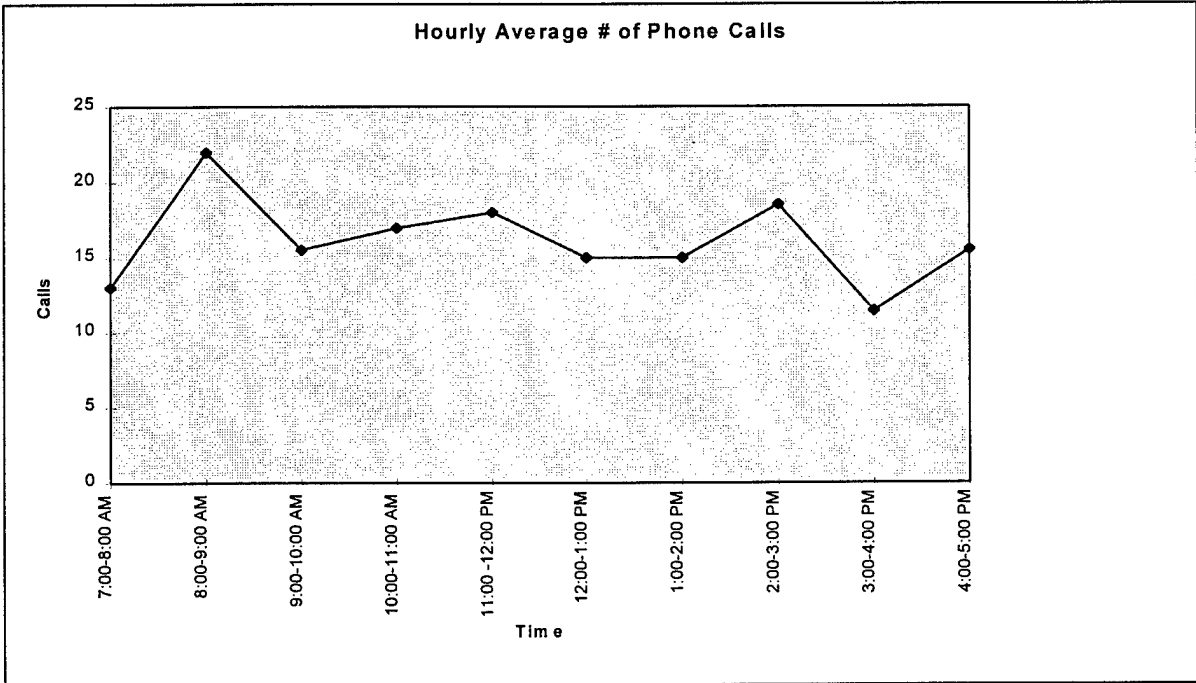
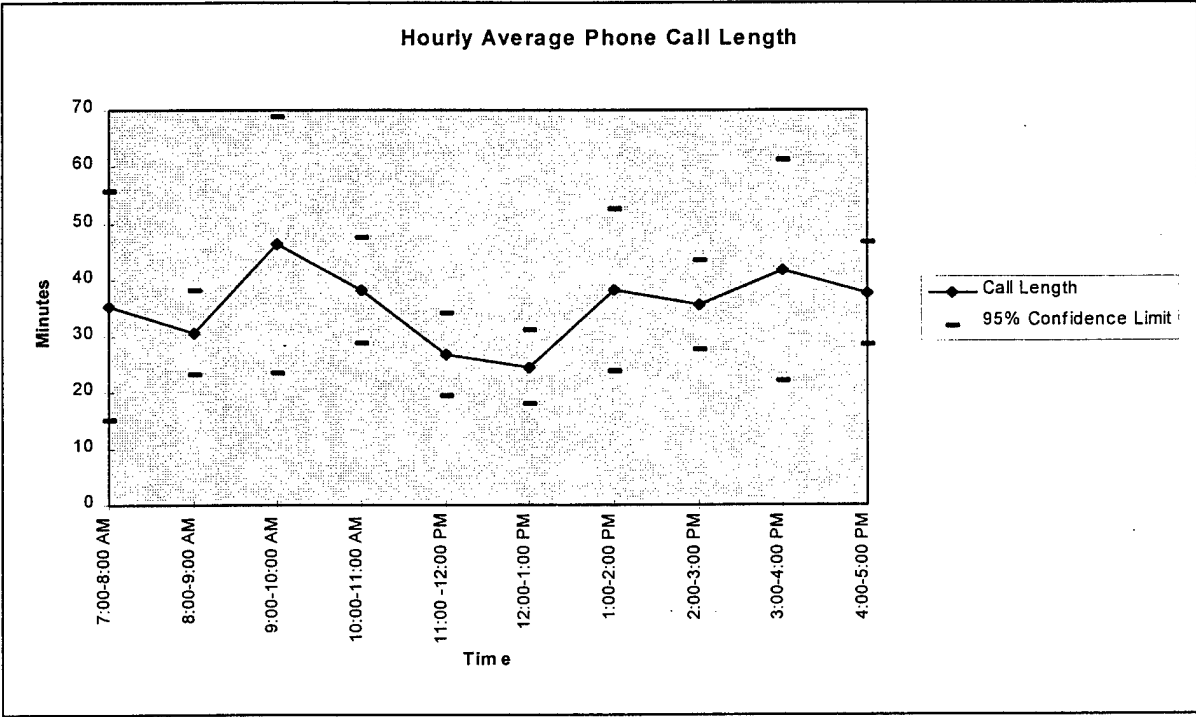

Results of Dispatcher Observation - Radio Calls							
Time	Mean Call Length (s)	Variance	Right 95% Confidence Limit	Left 95% Confidence Limit	Mean # Calls	Ave. Dev.	
7:00-8:00 AM	11.77	89.99	8.97	14.57	23	1.00	
8:00-9:00 AM	13.25	66.67	11.29	15.20	36	1.50	
9:00-10:00 AM	13.83	92.19	11.89	15.78	49	7.00	
10:00-11:00 AM	17.71	239.75	14.44	20.98	46	3.00	
11:00 -12:00 PM	12.82	46.86	11.43	14.21	48	0.50	
12:00-1:00 PM	14.13	84.72	11.99	16.27	41	4.50	
1:00-2:00 PM	13.57	107.55	11.26	15.89	45	18.50	
2:00-3:00 PM	12.57	79.95	10.62	14.52	44	10.50	
3:00-4:00 PM	12.88	75.04	10.95	14.80	44	2.50	
4:00-5:00 PM	12.89	62.04	11.09	14.70	38	5.50	
Overall	13.74	94.98	11.66	15.82	43	5.94	

Results of Dispatcher Observation - Phone Calls							
Time	Mean Call Length (s)	Variance	Right 95% Confidence Limit	Left 95% Confidence Limit	Mean # Calls	Ave. Dev.	
7:00-8:00 AM	35.34	2362.21	15.03	55.65	13	1.00	
8:00-9:00 AM	30.71	474.76	23.28	38.14	22	3.00	
9:00-10:00 AM	46.29	3443.31	23.74	68.85	16	6.50	
10:00-11:00 AM	38.26	752.11	28.90	47.62	17	1.00	
11:00 -12:00 PM	26.80	527.49	19.46	34.14	18	4.50	
12:00-1:00 PM	24.61	285.69	17.99	31.24	15	6.00	
1:00-2:00 PM	38.14	1447.41	23.79	52.49	15	3.00	
2:00-3:00 PM	35.60	564.44	27.61	43.58	19	2.50	
3:00-4:00 PM	41.67	1802.00	22.06	61.28	12	0.50	
4:00-5:00 PM	37.73	575.56	28.68	46.78	16	2.00	
Overall	35.54	1096.97	23.95	47.12	16	3.22	

APPENDIX B:
CHT PARATRANSIT DRIVER SURVEY

On a scale from 1 to 5, please indicate whether or not you agree with the following statements:

	Strongly Disagree	Disagree	Neutral	Agree	Strongly Agree
1. I am satisfied with the way driver-dispatcher radio communications currently work.	1	2	3	4	5
2. I usually get a response the first time I call out to the dispatcher.	4	3	3	3	
3. I find talking over the radio while driving to be a distraction.	1	2	3	4	5
4. With the appropriate training, I think I would be comfortable with the idea of using an MDT in my vehicle.	1	2	3	4	5
5. I think MDT's are a good idea.	1	2	3	4	5
	2		3	2	5

How much of the time do you have to call out to the dispatcher more than once before getting a response? (Circle one)

Never	Rarely	About 1/4 of the time	About 1/2 the time	More than 1/2 the time
	4	3	3	3

How often do you have repeat yourself or ask the dispatcher to repeat him/herself because a message was unclear? (Circle one)

Never	Rarely	About 1/4 of the time	About 1/2 the time	More than 1/2 the time
	3	3	4	3

About how many times per day do you find yourself waiting at a stop to find out where you need to go next? (Circle one)

0	1-3	4-6	7-10	More than 10
1	5	5	1	1

Do you ever leave a stop without knowing your next destination? Yes No

If yes, about how many times per day? _____ 1-2, 1-3, 2-3, 3, 3-4, 4, 4, 4-6, 20

What are the benefits of using the radio to communicate with the dispatcher?

Knowing where to go and who to pick up.

To find locations.

Directions may be needed.

Patron may have a question.

Roads may be blocked.

More people may need to ride.

Spur of the moment trips, it seems, could be handled more easily by an efficient radio system.

The radio is of no benefit to me because most of the time I can't get the dispatcher to answer. Also, a lot of times the drivers are talking on top of each other.

Emergencies! (What will MDT's provide for us?)

A voice for immediate response to varying (sometimes critical) situations that happen en route or at a point of pick up.

Responding to disabled vehicles and/or accidents.

Most times you can keep traffic flowing smoothly. I feel that MDT's would be more of a distraction. (too many buttons, placement in van, etc.) More cost-effective solution would be separate channels for fixed-route and EZ Rider.

Portability - if I get out of car to use bathroom, etc., I can easily carry radio with me.

Quick response - if I need assistance or dispatcher needs to make last-moment adjustments to schedule, radio seems quickest and easiest means.

Able to depart van and carry radio.

Help with details of unfamiliar pickups, the human touch.

What are the drawbacks of using the radio to communicate with the dispatcher?

Not being able to talk to the dispatcher when I need to.

May get a call while on turn or picking up.

A lot of radio traffic.

Clear (perhaps this person means unclear) communications between parties.

Driving and talking!

Radios do not have a stable place.

Too much radio traffic because we share frequency with driver 1's side. With good radio communication, we really run efficiently.

Mostly, the dispatcher not answering the radio.

Background interference, always hear the supervisors, fixed route dispatchers talking while EZ dispatcher is trying to give trip, and telephone ringing.

It all sounds very unprofessional on the airwaves. I've received numerous complaints about all the laughing, yelling, etc, when passengers hear this. Use of universal "10" codes would certainly help. Also, train dispatchers in "airwave etiquette", i.e., they fuss at drivers on the air, talk to us in a demeaning, sarcastic tone, or do not have a voice for radio communication at all (very muffled).

Difficulty getting through, understanding one another.

Tarheel Express needs to be on another channel. (also bus dispatcher)

Can't always tell when another driver is calling in.
Background noise.

What is your initial response to the idea of using an MDT in your vehicle?

I think it has potential, but I would think having radio backup would be advisable. Then again, I wonder if our radio system could be improved at a lot less expense.

I like the idea, mostly, but do have some reservations as stated in previous questions.

Would like to see it in operation before it's a permanent fixture here.

It's worth a try!

Very skeptical! I know nothing about MDT's but wonder where it would be mounted, how time-consuming to enter data, what happens when more than one driver enters data at the same

time, does it depend upon drop-offs and pick-ups being made in a certain order?

The change is welcomed.

O.K.

May be more effective and time consuming (Perhaps this person means less time consuming).

I think that this will be a good idea, if it won't take too much of the driver's time.

Bad idea.

Mild interest.

Please include any other comments you may have here:

MDT's may keep driver stationary - wouldn't be able to step out of van because waiting for next trip on computer screen.

If in danger, someone may not hear you.

I'd have to see what an MDT looks like and how it works to really give an opinion.

EZ Dispatcher should be two people in a sound proof room during peak hours.

Turn car shuttle over to fixed route dispatchers.

Weigh cost of equipment to another channel.

I'm not a raving Luddite but oftentimes greater technology leads to different problems rather than a blanket solution to problems.

**APPENDIX C:
MULTIPLE ATTEMPTS TO REACH
DISPATCHER -- A CTMC MODEL**

C.1 Problem Overview

In this model, we wanted to evaluate the percentage of the time that a driver receives response from the dispatcher upon his first attempt to relay a message. In other words, what is the probability that a driver attempting to relay a message will find the dispatcher to be free?

In order to answer this question, we modeled the activity of driver/dispatcher interaction as a Continuous Time Markov Chain (CTMC). In particular, this CTMC was based on a finite-source retrial queueing model, in which we make the following definitions and assumptions:

- **The state is defined by the dispatcher's availability, the number of drivers being served, and the number of drivers in "orbit".** An orbiting driver is one who made an initial attempt to receive service, but found the dispatcher busy, and is now retrying at a given rate. If the dispatcher is available (i.e., she is not occupied by the telephone or by fixed-route bus radio calls), then the current state is denoted by (**# in orbit, # being served**). If the server is unavailable while j customers are in orbit, the current state is denoted by U_j .
- **Any driver who does not receive dispatcher response on his first attempt to relay a message will automatically begin to orbit, retrying his call until he does receive a response.**
- **There are always five drivers on the road.** In actuality, the number of drivers fluctuates a little bit during the day, but the daily average is five vehicles.
- **When the dispatcher is on the telephone or using the radio to communicate with fixed-route vehicles, she will not respond to any incoming paratransit calls.** Observation showed that sometimes the dispatcher would respond to a radio call while on the phone, but this did not occur the majority of the time.
- **Upon entering a particular state, the system will remain in that state for a random, exponentially distributed amount of time.** This assumption allows for the "memoryless" property needed for a CTMC model: for any states X and Y in the system's state space, the probability that the system enters state Y from its current state X is dependent only upon the system's current state, and is independent of any of the system's previous states. In our model, we used observed dispatcher's booth activity to determine values for the rates at which the system moves between states. We assumed that these observed averages were parameters of exponential random variables.

A rate diagram of the model is on page C-3. The rate matrix is on page C-4. These two figures are followed by a discussion of parameters and how their values were determined.

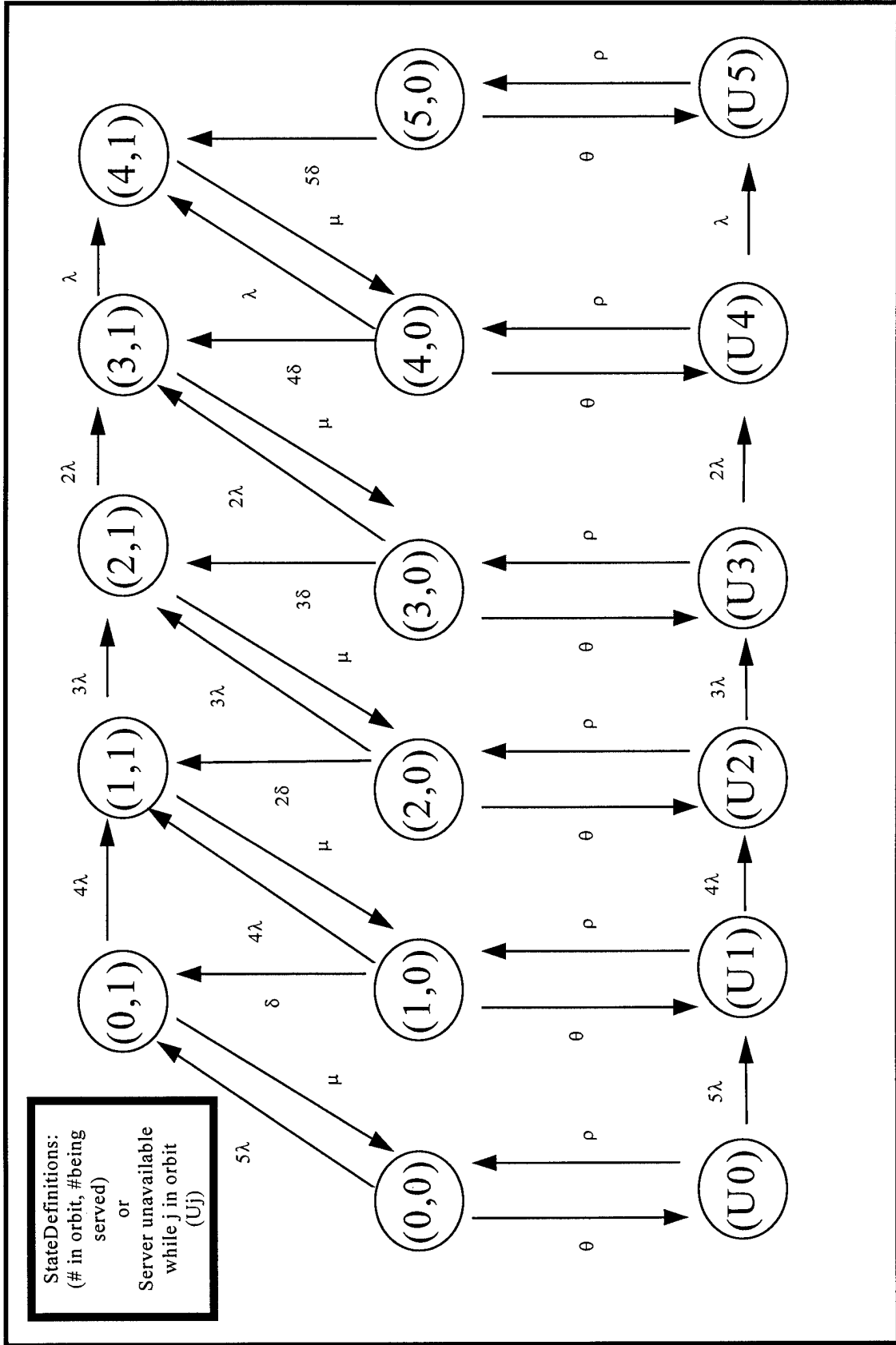

Figure C1 - Driver-Dispatcher Communication CTMC

	(0,0)	(1,0)	(2,0)	(3,0)	(4,0)	(5,0)	(0,1)	(1,1)	(2,1)	(3,1)	(4,1)	U0	U1	U2	U3	U4	U5
(0,0)	$-(5\lambda+\theta)$						5λ					θ					
(1,0)	$-(\delta+4\lambda+\theta)$						δ	4λ					θ				
(2,0)		$-(2\delta+3\lambda+\theta)$						2δ	3λ					θ			
(3,0)			$-(3\delta+2\lambda+\theta)$						3δ	2λ					θ		
(4,0)				$-(4\delta+\lambda+\theta)$						4δ	λ					θ	
(5,0)					$-(5\delta+\theta)$						5δ						θ
(0,1)	μ						$-\mu-4\lambda$	4λ									
(1,1)		μ						$-\mu-3\lambda$	3λ								
(2,1)			μ						$-\mu-2\lambda$	2λ							
(3,1)				μ						$-\mu-\lambda$	λ						
(4,1)					μ						$-\mu$						
U0	ρ											$-\rho-5\lambda$	5λ				
U1		ρ											$-\rho-4\lambda$	4λ			
U2			ρ											$-\rho-3\lambda$	3λ		
U3				ρ											$-\rho-2\lambda$	2λ	
U4					ρ											$-\rho-\lambda$	λ
U5						ρ											$-\rho$

Figure C2 - CTMC Rate Matrix

C.2 Data Collection and Parameter Estimates

The data used in this problem was the same data used for the dispatcher busy time analysis. In the dispatcher's booth, the number and duration of both incoming phone and radio calls was recorded. In addition, incoming radio calls from fixed-route vehicles were tracked. Although another individual in the dispatcher's booth actually answers these calls, they are important because they tie up the radio channel, forcing the dispatcher to become unavailable.

Each parameter was estimated for three different sets of data:

1. Activity between 9:00 and 10:00 am
2. Activity between 10:00 and 11:00 am
3. Activity over the whole 7:00 am - 5:00 pm observation period.

Since the dispatcher busy time analysis showed highest activity level during the 9-10:00 and 10-11:00 hours, we decided to run this model for each of those hours. We also wanted to see results for the whole observed day. The rest of this section will define each parameter and explain how it was computed.

The parameter λ is the rate at which any one vehicle generates first-attempt calls. It was not possible to observe λ , but the rate at which incoming calls reached the dispatcher, λ , was observed. The following equation relates λ and λ :

$$\lambda = 5\lambda(p(0,0) + p(U0)) + 4\lambda(p(0,1) + p(1,0) + p(U1)) + 3\lambda(p(2,0) + p(1,1) + p(U2)) \\ + 2\lambda(p(3,0) + p(2,1) + p(U3)) + \lambda(p(4,0) + p(3,1) + p(U5))$$

This formula comes from the fact that incoming calls are received at the same rate at which initial call attempts are generated. Furthermore, initial call attempts are generated at a rate proportional to the the number of vehicles which are not being served or in orbit. The formula conditions upon the state of the system to determine the rate at which initial call attempts are produced.

Since the steady-state probabilities are unknown, we needed to determine a way to approximate λ . We used the formula

$$\lambda = 5\lambda p_{free} + 4\lambda p_{busy},$$

where p_{free} is the fraction of time the dispatcher is not on the radio and $p_{busy} = 1 - p_{free}$. This approximation assumes that the probability that any vehicle is in orbit will be small. Our results are consistent with this assumption.

The parameter μ is the rate at which vehicle calls are serviced. It is equal to $3600/(\text{Average Observed Radio Call Length (s)})$.

The parameter δ is the rate at which a driver whose first message attempt did not receive response will retry to contact the dispatcher. This value was not actually observed. Three different values were used in each scenario; they corresponded to the driver waiting either 5, 10, or 15 seconds between retries. These values are appropriate choices, based on time spent on van rides.

The parameter θ is the rate at which the dispatcher becomes unavailable, either due to the arrival of a telephone call or fixed-route vehicle radio call. It was determined by summing the average number of incoming phone and fixed-route radio calls.

The parameter ρ is the rate at which the dispatcher goes from being unavailable to available. It is equal to

$$3600/(\text{Weighted Average of Observed Phone Call and Fixed-Route Radio Call Lengths (s)})$$

Figure C3 gives the estimates for each of the parameters:

	9:00-10:00 am (calls/hr.)	10:00-11:00 am (calls/hr.)	7:00 am-5:00 pm (calls/hr.)
λ	10.2	9.64	8.89
μ	260	203	262
δ	240/360/720	240/360/720	240/360/720
θ	26.7	27.7	26.7
ρ	106	122	131

Figure C3 - Parameter Estimates

C.3 Solving the Problem

Using these parameter values, we were able to find the steady-state probabilities that the system would be in each state. This problem was solved for nine different combinations of values (three scenarios, with three values of δ each). It was solved using the following equations:

$$\begin{aligned} \mathbf{pQ} &= \mathbf{0}; \\ \sum \mathbf{p} &= 1, \end{aligned}$$

where \mathbf{Q} is the CTMC's rate matrix, and \mathbf{p} is the vector of steady-state probabilities. The solutions to these equations was found by using Matlab, and they are shown in Figure C4.

Steady-State Probabilities

Based on Average Activity Level Between 7:00 am and 5:00 pm

	P(0,0)	P(1,0)	P(2,0)	P(3,0)	P(4,0)	P(5,0)	P(0,1)	P(1,1)	P(2,1)	P(3,1)	P(4,1)	P(0,2)	P(1,2)	P(2,2)	P(3,2)	P(4,2)	P(0,3)	P(1,3)	P(2,3)	P(3,3)	P(4,3)	P(0,4)	P(1,4)	P(2,4)	P(3,4)	P(4,4)	P(0,5)		
$\delta=240$	0.656	0.038	0.004	0	0	0	0.128	0.027	0.004	0	0	0.100	0.033	0.008	0.002	0	0.001	0.001	0.001	0.001	0	0	0.008	0.008	0.008	0.001	0.001	0	0
$\delta=360$	0.669	0.026	0.003	0	0	0	0.131	0.026	0.004	0	0	0.102	0.031	0.008	0.001	0	0.001	0.001	0.001	0.001	0	0	0.008	0.008	0.008	0.001	0.001	0	0
$\delta=720$	0.683	0.013	0.001	0	0	0	0.133	0.024	0.003	0	0	0.104	0.030	0.007	0.001	0	0.001	0.001	0.001	0.001	0	0	0.007	0.007	0.007	0.001	0.001	0	0

Based on Average Activity Level Between 9:00 and 10:00 am

	P(0,0)	P(1,0)	P(2,0)	P(3,0)	P(4,0)	P(5,0)	P(0,1)	P(1,1)	P(2,1)	P(3,1)	P(4,1)	P(0,2)	P(1,2)	P(2,2)	P(3,2)	P(4,2)	P(0,3)	P(1,3)	P(2,3)	P(3,3)	P(4,3)	P(0,4)	P(1,4)	P(2,4)	P(3,4)	P(4,4)	P(0,5)		
$\delta=240$	0.602	0.045	0.006	0.001	0	0	0.138	0.036	0.007	0.001	0	0.102	0.044	0.014	0.004	0	0.001	0.001	0.001	0.001	0	0	0.014	0.014	0.014	0.001	0.001	0	0
$\delta=360$	0.618	0.031	0.004	0.001	0	0	0.142	0.034	0.006	0.001	0	0.105	0.042	0.013	0.003	0	0.001	0.001	0.001	0.001	0	0	0.013	0.013	0.013	0.001	0.001	0	0
$\delta=720$	0.634	0.016	0.002	0	0	0	0.146	0.032	0.005	0.001	0	0.108	0.040	0.012	0.003	0	0.001	0.001	0.001	0.001	0	0	0.012	0.012	0.012	0.001	0.001	0	0

Based on Average Activity Level Between 10:00 and 11:00 am

	P(0,0)	P(1,0)	P(2,0)	P(3,0)	P(4,0)	P(5,0)	P(0,1)	P(1,1)	P(2,1)	P(3,1)	P(4,1)	P(0,2)	P(1,2)	P(2,2)	P(3,2)	P(4,2)	P(0,3)	P(1,3)	P(2,3)	P(3,3)	P(4,3)	P(0,4)	P(1,4)	P(2,4)	P(3,4)	P(4,4)	P(0,5)		
$\delta=240$	0.586	0.045	0.006	0.001	0	0	0.162	0.0462	0.009	0.001	0	0.095	0.036	0.010	0.002	0	0.001	0.001	0.001	0.001	0	0	0.010	0.010	0.010	0.002	0.002	0	0
$\delta=360$	0.601	0.031	0.004	0	0	0	0.166	0.044	0.008	0.001	0	0.098	0.035	0.010	0.002	0	0.001	0.001	0.001	0.001	0	0	0.010	0.010	0.010	0.002	0.002	0	0
$\delta=720$	0.618	0.016	0.002	0	0	0	0.171	0.0416	0.007	0.001	0	0.101	0.033	0.009	0.002	0	0.001	0.001	0.001	0.001	0	0	0.009	0.009	0.009	0.002	0.002	0	0

Figure C4 - Steady-State Probabilities

We expressed the probability that the driver has a successful first message attempt with this equation:

$$P\{\text{Driver Gets Through on First Try}\} = \frac{\text{(Rate of Message Arrival While Server is Free)}}{\text{(Total Arrival Rate)}}$$

In terms of steady-state probabilities, this can be written as:

$$P\{\text{Driver Gets Through on First Try}\} = \frac{[5p(0,0) + 4p(1,0) + 3p(2,0) + 2p(3,0) + p(4,0)]}{[5(p(0,0) + p(0,1) + p(U0)) + 4(p(1,0) + p(1,1) + p(U1)) + 3(p(2,0) + p(2,1) + p(U2)) + 2(p(3,0) + p(3,1) + p(U3)) + p(4,0) + p(4,1) + p(U4)]}$$

Figure C5 shows this probability for each of the nine versions of the problem:

Problem Version	P(Successful First Attempt)	P(Failed First Attempt)
7am-5pm, $\delta = 240$	0.708	0.292
7am-5pm, $\delta = 360$	0.708	0.292
7am-5pm, $\delta = 720$	0.707	0.293
9am-10am, $\delta = 240$	0.668	0.332
9am-10am, $\delta = 360$	0.668	0.332
9am-10am, $\delta = 720$	0.667	0.333
10am-11am, $\delta = 240$	0.651	0.349
10am-11am, $\delta = 360$	0.650	0.350
10am-11am, $\delta = 720$	0.649	0.351

Figure C5 - Problem Results

C.4 Summary of Results

The results of this model indicate that in peak hours, there is less than a 70% chance that the driver will reach the dispatcher on her first attempt to relay a message. This analysis confirms the driver survey results that multiple attempts to reach the dispatcher are a significant issue. It can also be noted that the value chosen for d doesn't significantly affect the problem's results, and that even the average daily activity observations indicate failed message attempts almost 30% of the time.

APPENDIX D:
CONTACTS

Company	Name	Phone Number
GMSI, Inc.	Greg Davis Senior Account Representative	(941) 481-9215
IRD-Teleride	Dana Aldercom Marketing Coordinator	(416) 408-9402
Mentor Engineering	Brent Freer Sales/Marketing	(403) 777-3764
NC State Highway Patrol	Dyke Hostettler NC Frequency Coordinator	(919) 662-4440
Sparcom Corporation	Larry Sparks Radio Consultant	(513) 761-7377
Transportation Management Solutions, Inc.	Mark Krueger Sales Manager, Eastern Region	(410) 850-7890, x4116
Trapeze Software Group	Mr. Dean Richardson Regional Sales Representative	(513) 474-7106

APPENDIX E:
UHF FREQUENCY SEARCH RESULTS

Kelly Mirone: Per phone call, LU frequency search from best to worst LU radio service... DKH

APCO APC, Inc.
Frequency Search Results
Short Form

Run Date: 04/03/97
Total Records Found: 15

Dist	TX Freq.	Latitude	Longitude	Callsign	Agency Name	ST	Cl	Svc	Power	ERP	Elev	AAT	Ant	Ht
97.73	452.70000	35- 2-58	78-52- 9	WPKH694	FAYETTEVILLE, CITY OF	NC	FXOT	PL	35.0					
55.62	452.72500	35-25-57	79-12-56	WPJT842	CAROLINA POWER AND LIGHT	NC	FXO	IW	5.0	50.0	149	97	53	
42.02	452.65000	35-32-59	79-10-21	WPJT842	CAROLINA POWER AND LIGHT	NC	FXO	IW	5.0	50.0	93	26	24	
40.58	452.42500	35-46-30	78-38-21	KNDL233	CAROLINA POWER & LIGHT	NC	FB2	IW	75.0	427.0	102		93	
38.56	452.82500	35-47-49	78-39- 9	WFP500	NORTH CAROLINA, STATE OF	NC	FX1	PS	45.0	90.0	101		23	
35.93	452.75000	35-35-32	79- 3- 0	WBYK588	CAROLINA POWER AND LIGHT	NC	FXO	IW	5.0	30.0	49		30	
34.00	452.32500	35-47-56	78-42-21	WGH675	NORTH CAROLINA, STATE OF	NC	FXO	PP	100.0	221.0	146		61	
32.81	452.47500	35-47-13	78-43-37	WYWQ765	W E MANGUM ENTERPRISES	NC	FB2	LJ	75.0	158.0	143		122	
22.30	452.62500	35-56-30	78-48-33	KGI916	CHF TRANSPORTATION INC	NC	FB2	LJ	75.0	422.0	131		91	
19.49	452.37500	36- 2-14	78-53-57	KCE487	DURHAM COUNTY HOSPITAL	NC	FX2	PS	75.0	250.0	122		46	
14.84	452.67500	36- 2-21	78-59-36	WNSA660	DURHAM, CITY OF	NC	FB2	LU	75.0	220.0	169		46	
2.15	452.85000	35-54-41	79- 4-41	WPBB860	CARRBORO, TOWN OF	NC	FB2	LV	25.0	75.0	143		43	
1.19	452.87500	35-54-17	79- 3-10	KNIW629	ORANGE, COUNTY OF	NC	FX	PS	45.0	225.0	149		43	
1.19	452.77500	35-54-17	79- 3-10	KNIW629	ORANGE, COUNTY OF	NC	FX	PS	45.0	225.0	149		43	
0.00	452.80000	35-54-55	79- 3-17	KAG662	CHAPEL HILL, TOWN OF	NC	MO	LU	75.0					

Frequency(s) Searched: 451.00000 to 453.00000000 Service: LU Sorted by: Dist From
 Distance Expressed as Km from Coordinates : 35-54-55 79- 3-17 State(s):

RADIO STATION LICENSE (reference only)

Licensee Name: CHAPEL HILL, TOWN OF
 Radio Service: LU Issue Date: 08/08/96
 Callsign: KAG662 Expire Date: 09/27/01
 Freq. Advisory #:
 Mobiles: Vehicular: 40 Portable: 5 Aircraft: Pagers:

TRANSPORTATION DEPT
 CHAPEL HILL, TOWN OF
 306 N COLUMBIA STREET
 CHAPEL HILL, NC 27514

TX Freq (MHz)	Class	Num	Emiss	Power	ERP	Elev	Ht to Tip	Latitude	Longitude
452.80000	MO	73	20K0F3E	75.0	0.0	0	0	35-54-55	79- 3-17
457.80000	MO	73	20K0F3E	75.0	0.0	0	0	35-54-55	79- 3-17
452.80000	FB	1	20K0F3E	75.0	0.0	0	43	35-54-55	79- 3-17

Aop : 136 EAST ROSEMARY ST
 CHAPEL HILL , NC ORANGE

Control Points:

Control Point Phone: 919-968-2755

Special Conditions:

APPENDIX F:
MINIPASS/AVL LETTER



Trapeze Software Group, Inc.

15880 N. Greenway Hayden Loop, Suite 200, Building A, Scottsdale, Arizona, U.S.A. 85260
Telephone (602) 627-8400, Fax (602) 627-8411

STATEMENT OF ACKNOWLEDGEMENT

Date: April 4, 1997
Project: Chapel Hill
Re: MDT Interface

Attention: Kelly Mirone

This statement of acknowledgement confirms that the MDT Interface is configurable with Trapeze MINIPASS; however, MINIPASS will not support AVL. There is no map capability or functionality for latitude or longitude coordinates.

Please forward any questions or comments you might have to my attention.

Regards,

Douglas J. Christensen
MDT Project Manager

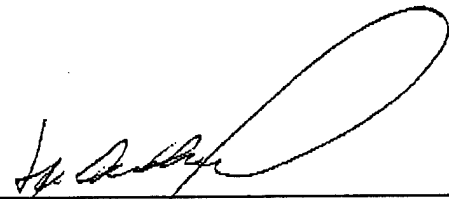
Victor Santillan
Product Manager

**APPENDIX G:
GMSI MDT FUNCTIONALITY**

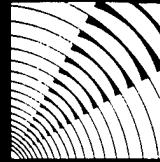

MDT 4100 Series - Status II

Mobile Data Terminal

Graphic Display

Downloaded
Forms Capability

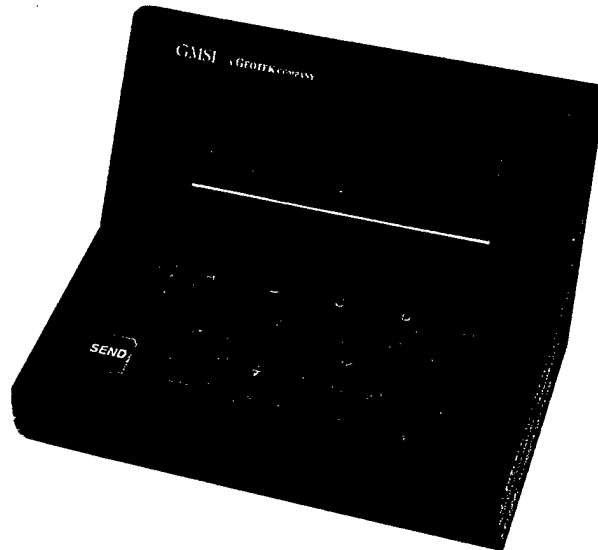

Flexible GPS
Reporting

Multiple
Communications
Networks

The MDT 4100 Series - Status *Mobile Data Terminal* (MDT) is a rugged in-vehicle terminal providing high speed data communications between dispatch center and fleet. Software is tailored to meet industry specific needs.

Software Applications:

- Taxi
- Fixed Route Transit
- Paratransit

Communications Networks Applications:

- Trunked radio systems
- Conventional full duplex channels
- Simplex channels
- Public data networks

Operation:

- Easy to learn and use
- Menu driven
- Large readable character display
- LED Backlit display and keypad
- Forms and status messages support
- Adjustable GPS reporting

Peripheral Support:

- Integrated odometer
- Emergency alarm
- Contactless smart card reader
- Magnetic card swipes

Setting The Standard In Computerized Mobile Data Communications Systems!

Specifications — Alpha/Status II & III

Offices

Physical	Item	Width	Height	Depth
Size (in/mm)	Integrated Display/Keypad - α/Status II	8/200	4.25/100	7/180
	Status III Keypad	2.9/74	3.88/98	1/25
	Status III Display	8.25/210	2.5/65	2/50
	MCU	7/180	1.5/40	5.25/133

Character Display Size Single Height - .15 in / 4 mm Double Height - .3 in / 8 mm

Power 13.8 Vdc nominal; full operation over 10 Vdc to 16 Vdc
Auxiliary Output 13.6 Vdc at 500Ma
30 Minute power off run timer

Current Consumption mA
MCU and Display/Keypad 500
GPS 350

CPU Motorola 68331, 32 microcontroller running at 16 Mhz

Memory 256 kbytes of reprogrammable memory (Flash ROM), expandable to 512 kbytes
128 kbytes of RAM, expandable to 512 kbytes

Programming The MCU application software and lists of forms and status messages can be upgraded through the programming port

Environmental

Temperature Operating: -22° to +140° Fahrenheit (-30° to +65° Celsius)
Storage: -50° to +160° Fahrenheit (-45° to +70° Celsius)

Mobile Environmental Testing SAE J 1455

Electromagnetic Compatibility CE Marking (Europe)

Network Operation Requirements

4115α
4113 Status II GSM (SMS), Geonet, MPT 1327 (Key), MPT 1327 (Mapp 27)

4125α
4123 Status II Conventional Channel, Simplex channel

4135α
4133 Status II E.F. Johnson trunking, Motorola trunking, EDAC's trunking

4122α
Status III Conventional Channel

GMSI, Inc.
275 Michael Cowpland Dr.
Kanata, Ontario
Canada K2M 2G2
Tel: (613) 599-5161
Fax: (613) 599-6425

GMSI, Inc.
10999 Metcalf
Overland Park, Kansas
USA 66210
Tel: (913) 451-3003
Fax: (913) 338-0997

GMSI, Inc.
2119 St. Mary's Street
Raleigh, North Carolina
USA 27608
Tel: (919) 420-7734
Fax: (919) 420-7736

GMSI, Inc.
33 Saddle Rock Road
West Greenwich, Rhode Island
USA 02817
Tel: (401) 397-8086
Fax: (401) 397-8514

GMSI, Inc.
3200 North Lake Shore Dr.
Suite 1501
Chicago, Illinois
USA 60657
Tel: (312) 929-3143
Fax: (312) 929-3144

GMSI, Inc.
18 The Crescent, Grants Hill
Ilford, Essex
England
IG2 6JF
Tel: (0) 181-554-0785
Fax: (0) 181-518-5987

GMSI, Inc.
c/o National Band Three
Wren House
Hedgerows Business Park
Colchester Park
Chelmsford, Essex
UK, CM2 5PF
Tel: (0) 171-396-3380
Fax: (0) 171-396-3377

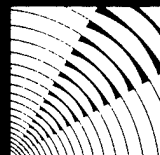

Section 7 - Mobile Data Terminal Requirements

7.1 Introduction

In this section ABC has listed the minimum MDT functionality that will be required of the successful vendor's MDCS.

7.2 MDT Functionality

1. At some future time ABC may desire to expand its MDT's functionality beyond its current requirements, therefore the successful vendor's MDT will have the capability to integrate and control devices such as card readers, GPS receivers, odometer readers, printers, vehicle sensors and mobile radios.
2. In order that ABC may integrate and control such devices as: card readers, GPS receivers, odometer readers, printers, vehicle sensors and mobile radios, the successful vendor's MDT will contain a minimum of 2 Mbytes of programmable memory (Flash ROM) and be expandable to 4 Mbytes.
3. The flash memory will be programmed by connecting a PC, running a configuration program, to one of the MDT serial ports.
4. In order that ABC may process the information collected and stored from such devices as: card readers, GPS receivers, odometer readers, printers, vehicle sensors and mobile radios, the successful vendor's MDT will contain a 32 bit processor.
5. Should the MDCS experience a communications failure, after ABC has downloaded the driver's manifest, the MDT will be capable of functioning independently of the MDCS base. This functionality will allow the driver to continue working from the manifest, thereby collecting and storing normal rider and trip data in the MDT. Once the data link between the MDCS base and MDT is restored, the MDT will prompt the driver to send the stored rider and trip data. In order for the MDT to be able to store an entire day's manifest and also be able to collect and store that day's rider and trip data it will contain a minimum of 128 Kbytes of RAM.
6. The MDT's transmission speed will be 3600 bits per second or faster.
8. MDT forms and prompts will be programmed from the MDCS computer via the radio link.
9. The MDT power will be controlled by the vehicle's run switch.
10. The MDT will be activated when the vehicle's run switch is turned on.
11. The MDT will be deactivated when the vehicle's run switch is turned off.

Mobile Data Terminal Requirements

12. ABC will have the option of having the vendor configure the MDT so that it will remain on and operational for a period of time, to be determined by ABC, after the vehicle's run switch has been turned off. This feature will allow ABC drivers to turn off the vehicle's engine and assist riders that are away from the vehicle while other riders remain on the vehicle, without losing trip information and collected data stored in the MDT.
13. The MDT will provide adequate filtering and protection to prevent interference from florescent lights and the vehicle's alternator.
14. The driver will be alerted of incoming messages by a buzzer. The buzzer will be located in the MDT and will be loud enough to be easily heard by the driver.
15. Using the keypad, the driver will acknowledge notification of incoming messages. Once the driver has acknowledged an incoming message it will be shown on the MDT display.
16. The driver will have twenty (20) seconds to acknowledge incoming messages. After twenty (20) seconds with no acknowledgment, the MDCS computer will transmit the message again. After a second and third attempt without acknowledgment, the MDCS computer will inform the communications supervisor of the driver's failure to acknowledge the message. The MDCS computer will store messages that have not been acknowledged.
17. ABC will have the option of configuring the MDCS computer so that it can specify the length of time the driver has to respond to incoming messages and the number of times the MDCS computer will transmit a message that has not been acknowledged.
18. Once the MDCS computer has re-established communications with the MDT, it will prompt the communications supervisor to transmit stored messages.
19. If the MDT fails to receive an acknowledgment from the MDCS computer after attempting to send a message it will prompt the driver to attempt to send the message again. After a second and third driver prompt and transmission attempt, without acknowledgment, the MDT will assume the vehicle is a poor radio coverage area and will prompt the driver to move the vehicle.
20. At any time after the driver has logged on to the system and received a trip manifest, the MDCS will update that manifest by inserting additional trips sent to it by the dispatch system computer. The driver will be alerted of a trip insertion message by the MDT buzzer. The driver will acknowledge receipt of the trip insertion by pressing the ACKN and SEND keys on the MDT keypad. The MDT will automatically insert additional trips in the order of their scheduled pick up or drop off times.
21. At any time after the driver has logged on to the system and received a trip manifest, the MDCS will update that manifest by canceling trips. The driver will be alerted of a trip cancellation message by the MDT buzzer. The driver will acknowledge receipt of the trip cancellation by pressing the ACKN and SEND keys on the MDT keypad. The MDCS will automatically delete the trip from the manifest and display "TRIP CANCELED" on the driver's display, where the deleted rider's address was originally shown.

7.2.1 MDT Display

1. The MDT will have a liquid crystal display screen.
2. The display will be back lit for night viewing.
3. The display screen will be capable of displaying a full ASCII character set with blinking, bold, and underlined characters.
4. The display screen will be capable of displaying both upper and lower case characters.
5. The display will show messages and trip assignments sent to the driver by the MDCS computer.
6. The display will have a minimum of six (6) lines, each containing a minimum of forty (40) characters.

7.2.2 MDT Keypad

1. The MDT keypad will allow drivers to communicate trip status updates and form messages to the dispatch center.
2. Each keypad button will be back lit for night viewing.
3. The MDT keypad will feature soft and hard coded function keys.
4. The hard coded keys will be fixed function keys programmed and labeled by the vendor and in conjunction with ABC.
5. The soft coded function keys will be menu driven and will change function depending on the menu context.
6. Initially the soft coded function keys will be programmed by the vendor and in conjunction with ABC.
7. The soft coded function keys will allow ABC to create or change the MDT's soft function keys at its discretion.
8. At a minimum, the MDT keypad will provide the following driver functions:
 - a) adjustment of the display contrast,
 - b) adjustment of the brightness of the display back light,
 - c) cancellation of an incorrect keypad sequence before sending information to the communications computer,
 - d) advancement of information displayed on the MDT display,
 - e) renewing the driver's manifest,
 - f) displaying driver messages,
 - g) displaying the manifest screen,
 - h) displaying an expanded manifest screen,

Mobile Data Terminal Requirements

- i) displaying a form screen,
- j) reporting the vehicle's arrival at a scheduled stop,
- k) reporting a scheduled rider has boarded the vehicle,
- l) reporting a scheduled rider has exited the vehicle,
- m) reporting the vehicle's departure from a scheduled stop,
- n) reporting that a rider is not at the pickup point (no show),
- o) reporting that a rider has canceled a trip at the pickup point (door cancellation),
- p) reporting that a rider has not come out to the vehicle and the driver wishes to give the supervisor the option of calling the rider (call out),
- q) requesting permission to speak to the supervisor on a voice channel,
- r) requesting priority permission to speak to the supervisor on a voice channel,
- s) signaling the supervisor of an emergency,
- t) acknowledgment of receipt of messages from the MDCS computer,
- u) transmission of canned coded messages,
- v) transmission of forms with numeric information, and
- w) completion of an MDT entry sequence that will send messages to the MDCS computer.

Section 8 - Driver Interface Requirements

8.1 Introduction

In this section ABC has listed the minimum driver interface functionality that will be required of the successful vendor's MDCS.

8.2 General Requirements

1. When the MDT is activated it will automatically conduct a self test to determine if it is functioning properly.
2. Once the MDT has passed its self test it will automatically display a driver log on form screen requesting the driver's identification number and the vehicle's odometer reading.
3. Drivers are to log on to the MDCS by entering their identification number and the vehicle's odometer reading into the MDT and then transmitting the information to the MDCS computer.
4. A successful log on will automatically indicate to the MDCS that the driver is available to receive and transmit messages.
5. The driver will be alerted of incoming messages by a buzzer located in the MDT.
6. Using the keypad, the driver will acknowledge incoming messages.
7. Once the driver has acknowledged an incoming message it will be shown on the MDT display.
8. ABC will have the option of downloading and storing up to one hundred (100) rider/trip stops in the MDT.
9. The driver will be able to scroll through the manifest.
10. All driver screens will display the current system time.
11. The system time will be depicted by a twenty-four (24) hour clock.
12. The system time will be set by the MDCS supervisor.

8.3 Driver Screens

The MDT will provide drivers with a Manifest Screen, Expanded Manifest Screen and Form Screens.

8.3.1 Manifest Screen

1. The Manifest Screen will provide drivers with an overview of their manifest.
2. It will display a minimum of six (6) lines of 40 characters each.
3. Additional trip message lines will be available by scrolling.
4. It will display a single line entry for each trip/stop.
5. All trips will be shown on the display in ascending order of scheduled stop times.
6. The current trip will be located at the top of the manifest.
7. When the driver completes the current trip, the MDCS will automatically delete it from the manifest.
8. The Manifest Screen will display multiple rider pick ups and drop offs from the same address.
9. At any time after the driver has logged on to the system and received a manifest, the MDT will update the manifest by inserting additional trips sent to it by the dispatch system. The MDT will insert jobs in the order of their scheduled pick up or drop off times.
10. At any time after the driver has logged on to the system and received a manifest, the MDT will update the manifest by deleting trips that have been canceled.
11. The driver will be able to access the Form Screens from the Manifest Screen by a single key stroke, using an MDT keypad key.
12. The driver will be able to access the Expanded Manifest Screen from the Manifest Screen by a single key stroke, using an MDT keypad key.
13. The following is an example of ABC's proposed Manifest Screen.

+	7:00	1010	Pine St.,	Seattle
-	7:30	2109	Steele St.,	Seattle
+	7:36	5155	James St.,	Seattle
+	7:45	2300	Reedy Creek Rd.,	Seattle
+	7:52	2119	ST. Mary's St.,	Seattle
-	8:00	2454	Pear Orchard Ln.,	Seattle

- a) A "+" to indicate a pick-up, or a "-" to indicate a drop off will be the first character on each line.

- b) After the "+" or "-" sign, the screen will show the scheduled stop time. If the driver has a scheduled stop time window, such as 6:30 a.m. to 7:00 a.m., the screen will display the latest time (7:00 a.m.) that the driver can arrive at the stop.
- c) After the stop time the line will show the stop address.

8.2.2 Expanded Manifest Screen

1. The Expanded Manifest Screen will provide the driver with detailed information about each stop.
2. The Expanded Manifest Screen will display a minimum of six (6) lines of 40 characters each.
3. Additional lines of trip information will be available by scrolling.
4. The driver will be able access the Manifest Screen from the Expanded Manifest Screen by a single key stroke, using an MDT keypad key.
5. The driver will be able to access the Form Screen from the Expanded Manifest Screen by a single key stroke, using the an MDT keypad key.
6. The following is an example of ABC's proposed Expanded Manifest Screen.

```
+ 7:00 1010 James St., Seattle  
Mary Logan   Fare $3.00   209618844  
01-Rider 01-Attend 00-Comp Trip # 011850  
Go to back entrance. Attendant must  
assist in loading rider. Attendant  
fare $3.00
```

- a) The first line of the Expanded Manifest Screen will display a "+" to indicate a pick up or a "-" to indicate a drop off, the scheduled stop time and the stop's street address.
- b) The second line will display the rider's name, fare amount and ABC customer number.
- c) The third line will display the number of riders, attendants and companions to be picked up or dropped off, and the dispatch system generated unique trip number.
- d) The forth, fifth and sixth lines will display additional information about the rider or stop, such as map-page and location references, special instructions or comments.

8.2.3 Form Screens

1. Form Screens will display a list of information requests to be filled in by the driver and transmitted to the MDCS computer.
2. The driver will be able to access the Form Screens from either the Manifest Screen or Expanded Manifest Screen by using an MDT keypad key.

Driver Interface Requirements

3. After the driver has used the MDT to record a rider's boarding, ABC will have the option of automatically displaying Form Screens to be filled in by the driver and transmitted to the MDCS computer, before the driver can return to any other screen.
4. If a Form Screen requires the vehicle's odometer reading, the MDT will automatically read and fill in odometer reading.
5. If the rider and trip numbers, number of riders, attendants and companions, and fare amounts and types were in the original trip message transmitted to the MDT, the MDT will automatically place that information in the appropriate Form Screen fields. The driver will be able to change information entered by the MDT.
6. The following are examples of ABC's proposed driver Form Screens.

Odometer [0012932]
Rider # [825184683]
Trip# [01420]
Riders [01]
Fare [\$3.00]
Rider Fare Type [01]

- a) Line one (1) will request the vehicle's odometer reading.
- b) Line two (2) will request the rider's identification number.
- c) Line three (3) will request the dispatch system generated trip number.
- d) Line four (4) will request the number of riders.
- e) Line five (5) will request the fare amount collected from the rider.
- f) Line six (6) will request the type of fare media used by the rider, i.e. cash, token, pass, transfer, etc.

Section 9 - Data Collection & Service Monitoring Requirements

9.1 Introduction

In this section ABC has listed the data collection and service monitoring features that will be required of the successful vendor's MDCS.

9.2 Real-Time Messaging

1. The successful vendor's MDCS will send, receive, and store all driver messages in real-time.
2. The time and date at which messages are transmitted and received will be recorded.
3. The identity of the individual transmitting a message and that of the individual acknowledging receipt of the message will be recorded.
4. Once the MDCS computer has transmitted a driver message and received an acknowledgment of receipt of the message, the message will be stored on the dispatch system computer.
5. Once the MDCS computer has acknowledged receipt of a driver message, the message will be stored on the dispatch system computer.

9.3 Coded Driver Messages

It is ABC's intent that drivers will use the MDT to transmit coded or canned messages to the MDCS computer. It is also ABC's intent that such activity will cause the MDT to automatically collect and transmit the following information:

1. message content,
2. driver identification number,
3. vehicle identification number,
4. time and date of transmission,
5. vehicle odometer reading, and
6. vehicle longitude and latitude.

9.4 Log On

It is ABC's intent that drivers will use the MDT to log on to the MDCS. It is also ABC's intent that the log on activity will cause the MDT to automatically collect and transmit the following information to the MDCS computer:

1. log on activity,
2. driver identification number,
3. time and date of transmission,
4. vehicle identification number,
5. odometer reading, and
6. vehicle longitude and latitude.

9.5 Log Off

It is ABC's intent that drivers will use the MDT to log off of the MDCS. It is also ABC's intent that this log off activity will cause the MDT to collect and transmit the following information to the MDCS computer:

1. log off activity,
2. driver identification number,
3. time and date of transmission,
4. vehicle identification number
5. odometer reading
6. vehicle longitude and latitude

9.6 Pick Up Site Arrival

It is ABC's intent that drivers will use the MDT to indicate that the vehicle has arrived at a scheduled pick up site. It is also ABC's intent that this MDT activity will collect and transmit the following information to the MDCS computer:

1. pick up site arrival,
2. rider identification number,
3. dispatch system generated trip number,
4. vehicle identification number,
5. time and date of transmission,
6. vehicle odometer reading, and
7. vehicle longitude and latitude.

9.7 Pick Up Site Departure

It is ABC's intent that drivers will use the MDT to indicate that the vehicle is departing a scheduled pick up site. It is also ABC's intent that this MDT activity will collect and transmit the following information to the MDCS computer:

1. pick up site departure,
2. rider identification number,
3. dispatch system generated trip number,
4. vehicle identification number,
5. time and date of transmission,
6. vehicle odometer reading, and
7. vehicle longitude and latitude.

9.8 Drop Off Site Arrival

It is ABC's intent that drivers will use the MDT to indicate that the vehicle has arrived at a scheduled drop off site. It is also ABC's intent that this MDT activity will collect and transmit the following information to the MDCS computer:

1. drop off site arrival,
2. rider identification number,
3. dispatch system generated trip number,
4. vehicle identification number,
5. time and date of transmission,
6. vehicle odometer reading, and
7. vehicle longitude and latitude.

9.9 Drop Off Site Departure

It is ABC's intent that drivers will use the MDT to indicate that the vehicle is departing a scheduled drop off site. It is also ABC's intent that this MDT activity will collect and transmit the following information to the MDCS computer:

1. drop off site departure,
2. rider identification number,
3. dispatch system generated trip number,
4. vehicle identification number,
5. time and date of transmission,
6. vehicle odometer reading, and
7. vehicle longitude and latitude.

9.10 Rider Boarding

It is ABC's intent that drivers will use the MDT to indicate that scheduled rider has boarded the vehicle. It is also ABC's intent that this MDT activity will collect and transmit the following information to the MDCS computer:

1. boarding activity,
2. rider identification number,
3. dispatch system generated trip number,
4. vehicle identification number,
5. time and date of transmission,
6. vehicle odometer reading, and
7. vehicle longitude and latitude.

9.11 Rider Alighting

It is ABC's intent that drivers will use the MDT to indicate that scheduled rider has alighted the vehicle. It is also ABC's intent that this MDT activity will collect and transmit the following information to the MDCS computer:

1. alighting activity,
2. rider identification number,
3. dispatch system generated trip number,
4. vehicle identification number,
5. time and date of transmission,
6. vehicle odometer reading, and
7. vehicle longitude and latitude.

9.12 Rider Call Out

It is ABC's intent that drivers will use the MDT to request a rider call out. It is also ABC's intent that this MDT activity will collect and transmit the following information to the MDCS computer:

1. call out request,
2. rider identification number,
3. dispatch system generated trip number,
4. vehicle identification number,
5. time and date of transmission,
6. vehicle odometer reading,
7. vehicle longitude and latitude, and
8. call out request approved or disapproved.

9.13 Rider No Show

It is ABC's intent that drivers will use the MDT to request permission to conduct a rider no show. It is also ABC's intent that this MDT activity will collect and transmit the following information to the MDCS computer:

1. no show request,
2. rider identification number,
3. dispatch system generated trip number,
4. vehicle identification number,
5. time and date of transmission,
6. vehicle odometer reading,
7. vehicle longitude and latitude, and
8. no show approved or disapproved.

9.14 Rider Door Cancellation

It is ABC's intent that drivers will use the MDT to indicate that a rider has canceled the trip at the pick up site. It is also ABC's intent that this MDT activity will collect and transmit the following information to the MDCS computer:

1. door cancellation,
2. rider identification number,
3. dispatch system generated trip number,
4. vehicle identification number,
5. time and date of transmission,
6. vehicle odometer reading, and
7. vehicle longitude and latitude.

9.14 Rider Fares

It is ABC's intent that drivers will use Form Screens to collect and transmit the following rider, attendant, and companion fare information: fare amount, fare type such as cash, pass, ticket, token, transfer, etc.

APPENDIX H:
MENTOR CONTACT LIST



CUSTOMER REFERENCES

Paratransit Systems

Since 1988, Mentor systems have successfully met small and large fleet dispatch requirements in ten major industries across North America and Internationally.

Sante Fe Ride

Contact: Rob McArthur
Ph. (505) 438-1463

System Description - We implemented 24 MDTs with ID card readers for passenger validation as well as integrated smart taxi meters to track individual taxi fare amounts.

South West Metro Transit

Contact: Tom Juhnke or Chuck Snyder
Ph. (612) 934-7928

System Description - This system is operating over a Johnson LTR radio system and has 22 MDTs (typically 14 vehicles are operational at one time).

Stanislaus County

Contact: Troy Holt
Ph. (209) 525-6552

System Description - 10 MDTs with GPS receivers and odometer monitoring operating over a conventional radio system on a community repeater.

Anoka Transit

Contact: Tim Kirchoff
Ph. (612) 477-7088

System Description - Anoka's 16 vehicle fleet was equipped with the Express MDT.

Sunvan - City of Albuquerque

Contact: Dan Hogan
Ph. (505) 764-6185

System Description - 45 MDTs with odometer tracking and GPS receivers in operation over an EDACS radio system. This system features a DGPS reference station at the dispatch office that delivers an accuracy of plus or minus eight meters.

Other Paratransit Projects

Everett Transit - Everett, WA - 11 vehicles
Bi-State Transit - Saint Louis, MO - 80 vehicles
Pierce County - Tacoma, WA - 88 vehicles
STS - Charlotte, NC - 63 vehicles

Other System References

Checker Cabs

Contact: Wayne Maki
Ph. (403) 299-4950

System Description - Checker Cabs operates a taxi fleet of 550 vehicles with our EXPRESS MDT and an in-house software system. This system is operating over conventional (VHF) radio.

Boston Coach Limousine (Fidelity Investments)

Contact: Doug Collette
Ph. (617) 563-6375

System Description - Boston Coach operates a black car style of service in the Boston area. Their fleet is over 135 vehicles in the Boston area and they are using an in-house dispatch software package. Radio backbone is the Johnson LTR radio system.

Petro Canada Inc. (Oil and Gas Exploration)

Contact: Walter Geist
Ph. (604) 785-4431

System Description - Petro Canada's field operators are using over 100 of Mentor's mobile data terminals to access information and receive alarms from gas compressor sites and MAN DOWN alarms.

CO-OP Taxi Line

Contact: Rita Curtiss / Connie Loeder
Ph. (403) 425-0954

System Description - CO-OP replaced their Gandalf MDTs with Mentor's EXPRESS MDT in their fleet of 480 vehicles.

AAA - Florida - Heathrow, FL

Contact: O.S. Brannon
Ph. (407) 444-4360

System Description - AAA Florida has installed Express MDTs in 200 of their contractor's tow trucks. The RAM network was chosen as the wireless link from the dispatch office to the trucks in the field because of it provided the best coverage and capacity available.

Alberta Motor Association (AMA) - Edmonton, AB

Contact: Alec Strap
Ph. (403) 430-5554

System Description - The Express MDT is installed in the Alberta Motor Association's fleet of 140 trucks in the cities of Calgary and Edmonton. The Express Gateway was integrated into the AMA's in-house software package and also a combined VHF and UHF radio system.

APPENDIX I:
MENTOR MDT FUNCTIONALITY

MENTOR
ENGINEERING

MOBILE DATA TERMINAL

TX CHAN

MSG

Engineering Mobile Data Solutions

F1

F2

F3

F4

1

2

3

4

5

6

7

8

9

CLEAR

0

ENTER

MORE

EXIT



EXPRESS Mobile Data Terminal

EXPRESS MDT Peripheral Equipment

For many systems, a mobile data terminal may be only part of the solution. To accommodate the addition of peripheral equipment for special functions or system upgrading, the EXPRESS MDT has multiple RS232 ports, a keyboard interface port and field programmable software. The following outlines some of the peripheral equipment which can be interfaced to the EXPRESS MDT:

GPS Receivers: Integrate GPS receivers into your system for Automatic Vehicle Location (AVL) tracking.

Mobile Keyboards: Mentor offers a keyboard for those applications requiring significant text entry.

Bar Code/Credit Card Readers: These devices simplify data collection.

Mobile Printers: Print out invoices, receipts or instructions.

Load Sensors: Record load information for applications such as cement delivery, trucking, or waste disposal.

Smart Taxi Meters: All fare and other meter information can be collected for various management control functions.

The flexibility of the EXPRESS MDT lets you start with a basic system and add functionality as required.

EXPRESS MDT Communications

The EXPRESS MDT has been designed by engineers experienced in both mobile radio and data communications, resulting in an MDT that is extremely versatile when it comes to interfacing to your radio equipment.

The EXPRESS MDT offers:

- A built-in packet radio modem, containing the intelligence and control circuitry required for interface to virtually any model or style of conventional or trunked radio.
- Built-in intelligence eliminates all redundant overhead in your data messages. Communications efficiency is far greater than found in dumb ASCII terminals.
- CRC16 error checking and message handshaking with automatic message retransmissions ensures accurate, error free communication.
- Channel busy monitoring allows for voice and data to share the same radio channel without interfering with each other.
- For use on alternative data networks, it has an RS232 port for interfacing to 3rd party equipment.

Mobtex Network Compatible

EXPRESS MDT Specifications

General:

- o 4 x 40 LCD display with back lighting
- o Sealed membrane keypad with back lighting
- o Rugged metal case
- o LED indicators for TX, Channel and Messages

Internal

- o Built-in Bell 202 FSK modem with automatic gain control (AGC) and automatic TX level
- o Motorola CMOS MC68HC11 microprocessor
- o 2 RS232 ports
- o 1 keyboard interface port (RJ11)
- o 2 definable inputs
- o 2 definable outputs
- o 64K Flash EPROM
- o 512 bytes EEPROM
- o 32K RAM
- o Internal 5 tone paging encoder (optional)

Size/Weight:

- o 9.25"W x 3.5"H X 1.75"D
- o 235mmW X 89mmH X 44mmD
- o 30 ounces / 750 grams

Temperature/Humidity

- o -40°F to +150°F / -40°C to +65°C
- o 0 - 95% non-condensing max

Power

- o 9 - 18 VDC
- o Complete transient protection

Your local authorized Dealer is:

Mentor Engineering, Inc.

#503, 609 - 14th Street N.W.
Calgary, AB, Canada T2N 2A1
Ph. (403) 283-6763
Fax (403) 283-6749

EXPRESS YOURSELF EXPRESS YOURSELF EXPRESS YOURSELF

Express Mobile Data System

Paratransit System Technical Specifications

Overview

Hardware

The MDT hardware should consist of a single enclosed unit so that it is easily installed in the vehicle. The unit should house a display, keypad, radio modem, and GPS receiver (if required).

The MDT should be compact. It should be no larger than 10"W by 3"H so that it is easily mounted and unobtrusive.

The MDT should feature a rugged aluminum enclosure.

The MDT should feature a membrane keypad with no moving parts to increase longevity.

The MDT should operate from -40°F to 150°F

The MDT display should have fully adjustable contrast so that the changes in temperature will not affect the driver's ability to read the display.

The MDT should have a 4 line by 40 transfective display with eight levels of backlighting so that the driver will be able to read the display under all lighting conditions.

The MDT should feature LED indicators that indicate the transmission of data, and receipt of messages.

Functional Overview

The system has to be able to transmit from the central dispatch to specific vehicles the following information :

- 1) Passenger name
- 2) Passenger pick-up address including: number, street, city, apartment/suite
- 3) Passenger drop-off address including: number, street, city, apartment/suite/doctor
- 4) Passenger special equipment information: wheelchair, walker, oxygen, etc.

- 5) Passenger's scheduled pick-up time
- 6) Passenger's destination appointment time
- 7) Total number of passengers
- 8) Canceled trip
- 9) Thomas brothers map page and location reference
- 10) Special text instructions or messages

MDT should sort jobs based on their priority and the driver's schedule so that the job on the top of the screen will always be the next for the driver to perform.

System should be able to insert additional trips into a group of trips that has already been sent to the MDT in a specific pick-up and drop-off order.

The MDT should automatically acknowledge the receipt of information from the dispatch office.

Each MDT must have a unique ID number and a method for grouping them that can be used to separate vehicle types (i.e. supervisor, wheelchair, non-smoking, etc.)

All messages (except broadcasts) should receive automatic acknowledgments from the receiving unit to verify a completed transmission. Should a transmission fail the message would be automatically retransmitted a programmable number of times. In the case of communications failure the driver must be notified that an error has occurred. In addition the MDT should have an LED light indicating channel quality.

MDT should store a minimum of eight structured forms or message formats

MDT should store received messages and give the driver both visual (message LED flashes) and audible (programmable beeping sequences) indication of a new message arrival. Priorities assigned to incoming messages allow the driver to see important messages immediately while less important messages can be stored for the driver to retrieve later.

The MDT should support free form text messaging for general information and personal messaging.

The ability of the dispatcher to send "Yes/No" or "Accept/Reject" messages means that the driver can be prompted to take a course of action.

The dispatcher should be able to be reassign jobs from one MDT to another, change job information, and delete jobs from the MDT in case of cancellation or reassignment.

MDT must be able to transmit data from a specific vehicle to the central dispatch and update corresponding information in the dispatch system such as:

- 1) Driver acknowledged receipt of pick-up
- 2) Time driver arrived at passenger pick-up
- 3) Time passenger picked-up
- 4) Time passenger arrived at destination
- 5) Time passenger dropped off
- 6) Trip odometer reading
- 7) Rider fare information
- 8) Total number of passengers
- 9) Confirmation of canceled trip initiated by dispatcher
- 10) Passenger no-show (to be verified by dispatcher)
- 11) Additional programmable messages

MDT must be capable of the following criteria:

- 1) Ability to sort rides on a numeric field
- 2) Host clearing of rides
- 3) Receive messages from the host
- 4) Transmit canned messages to the host
- 5) Send data in a preset format to the host

MDT Display

MDT will display trip information on both manifest view and expanded view display screens.

Manifest view consists of a single line entry for all the available trips with the current trip being highlighted. The driver should be able to view available trips not currently on the display by scrolling up or down

Expanded view allows the driver to view detailed information about any one trip. Pressing the function key that corresponds to a particular trip should enable the driver to see the expanded view of that trip.

MDT should be able to support peripheral devices such as:

- 1) AVL/GPS receivers
- 2) Card readers/bar code readers
- 3) Printers
- 4) Odometer loggers

Function Keys

The MDT should provide programmable function keys for:

- 1) Login
- 2) Arrival
- 3) Pick-up Made
- 4) Drop-off Made
- 5) No-show
- 6) Renew
- 7) Page-up
- 8) Page-down
- 9) Mail
- 10) Snd/Msg
- 11) Message Confirmed
- 12) Request to Talk
- 13) Available
- 14) Emergency
- 15) Breakdown
- 16) Clear to Garage

Function keys will automatically change depending on the information displayed on the screen thereby reducing driver keystrokes.

The MDT should display these functions in a vertical list on the MDT.

The MDT should have macros associated with its' function keys so that a number of functions can be performed with a minimum number of driver keystrokes.

Additional Features:

VIEW NEW function key - Should the driver receive multiple new messages and is not sure of what information is new. the VIEW NEW function key allows the driver to scroll through the new information in the order that it was received. New information could be any combination of general manifest information, personal messages etc.

Store and Forward - Should the data transmission fail, the MDT will wait a specified (programmable) time period and then automatically retry the message transmission. The original time stamp and odometer will be maintained.

Quick Keys - Function keys can be hard coated on to the MDT keypad overlay to provide easy access to common functions. Custom graphics can also be added to the MDT overlay.

Fare Structure Programmability - Mentor can customize the MDT data entry structure on fare codes to meet the specific requirements of the Paratransit operation. Our function keys can have macros programmed with them so when the driver pushes a PERFORM or FARE key, the driver can be prompted to enter in information particular to the individual requirements. The data entry can be either one level (e.g. driver only prompted to enter in one piece of information or multiple levels where the driver can enter in multiple pieces of information

ID Card Matching - When a passenger swipes their ID card, the MDT will match the incoming ID information to the appropriate trip on the MDT screen. Once the match is met, the MDT will send in a PERFORM function automatically.

Future Communication System - Should at anytime the radio frequencies of the contractors be refarmed by the FCC or for any reason the current communication systems be unavailable for use in the future, the MDT is fully compatible with alternative wireless data networks such as RAM Mobile Data, Ardis, CDPD, and GE EDACs.

APPENDIX J:
MENTOR SYSTEM QUOTE

D. Products

Express Plus Mobile Data Terminal (MDT)

Price includes a built-in radio modem, a basic mounting bracket, and a standard keypad overlay. An internal eight channel GPS receiver is optional.

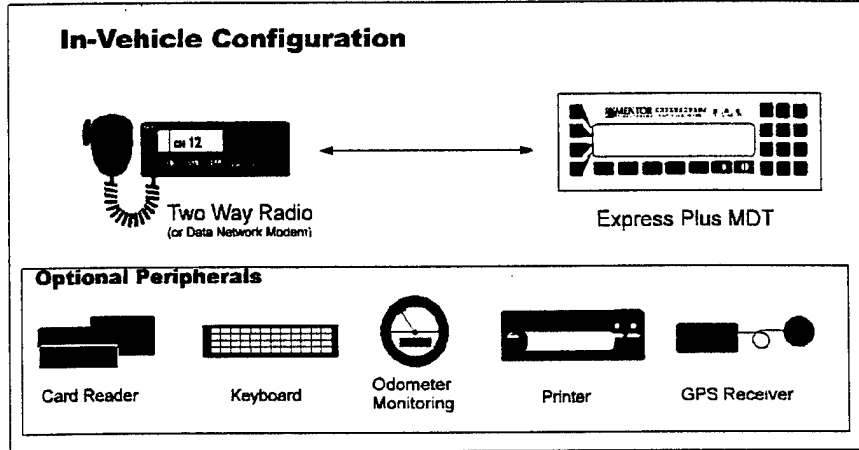

Express Plus Master Communications Controller (MCC)

The MCC provides the interface between the host computer and the base station radio equipment. The MCC must be located at the base station radio. If this base station is remote from the host software system, a dedicated land line connection is required. We typically use Motorola UDS V.3225 modems for this connection.

XGate Software License

XGate provides the link between the host software system and the Express Plus mobile data equipment. This software module resides on a PC that would be part of the PC network operating the dispatch/data collection application.

XGate will support multiple channels (up to 16) which can consist of MCCs or links to 3rd party data networks such as RAM/Ardis/CDPD/Satellite. This Gateway also provides a data logging feature for system diagnostics.

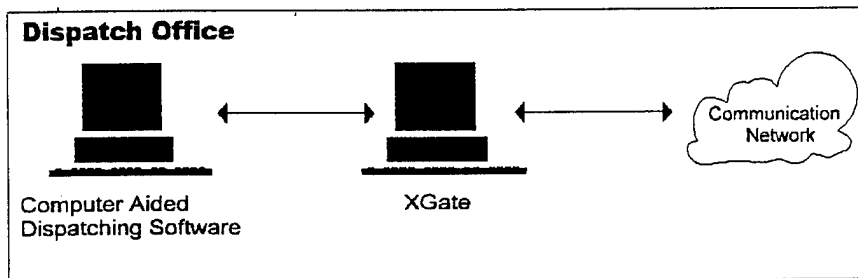

E. Communication System Summary

The communication system was not identified for the purposes of this proposal so all radio related engineering fees have been based on a conventional radio system with mobile radios that we have previously used for such a project.

F. Project Flow

This project will require a phased implementation as follows:

Radio System Evaluation Phase

Mentor Engineering will provide an on-site engineer for a period of one week to evaluate the coverage and capacity of the proposed communications system. The goal of this phase is to determine the suitability of the proposed radio system for data communications. The following items will be required of Chapel-Hill to facilitate this testing:

- A data group set-up on the radio system for the evaluation period.
- A vehicle, driver, and test route for coverage testing.
- Three spare mobile radios: initially sent to Mentor for interface testing and then provided to the communications provider for bench testing.

The system evaluation phase will consist of the following sequence of events:

- Mentor will provide the communications service provider with the appropriate installation guide for the mobile radios so that both preliminary setup and testing is completed before an engineer arrives on site. Radio interfaces to at least three mobiles will be completed by the communications provider prior to Mentor arriving on site.
- The first stage of the system evaluation is a coverage test. Mentor's project engineer will test the coverage of the radio system under normal operating conditions and plot the results geographically. If upon a review of the test results it is concluded that the radio system coverage is inadequate methods to improve the current system's coverage characteristics and/or other communications options will have to be investigated.
- The second stage of testing is a series of loading tests, conducted to gather channel capacity data. The engineer will configure the radio system as it will be configured for the system installation and then log the results of a series of tests using the 'auto-exercise' utility of Mentor's XGate software. Both of the mobile radios interfaced by the communications provider prior to the on-site visit would be required for this stage of the testing.

Once the performance of the radio system has been signed off as being satisfactory by Mentor, Trapeze, and Chapel-Hill, the project will proceed with the pilot phase.

Pilot Phase

The goal of the pilot phase of the project is to prove out the end-to-end operation of the system with a small group of vehicles. Mentor will provide an on-site engineer for a period of one week during the pilot phase. Chapel-Hill will again be required to supply a data group on the radio system during the pilot phase to facilitate testing.

The pilot phase will consist of the following sequence of events:

- Mentor will ship the communications provider five (5) complete sets of in-vehicle hardware including Express Plus MDTs pre-programmed with the appropriate firmware, cabling, and stands. The communications provider will install and test the equipment in five of Chapel-Hill's vehicles before Mentor staff arrives.
- Mentor will pre-configure the XGate PC and ship it to Chapel-Hill. Chapel-Hill will be responsible for providing space, power, and a network connection for the XGate PC. The XGate PC needs to be installed within fifty feet of the dispatch radio.
- Mentor's on-site staff will: establish communications on the radio system; bring the pilot vehicles on-line; perform XGate logging of data communications; prove out the operation of the mobile data system with the host MDT application running; evaluate the system performance; and deal with minor issues as they arise.

Once the end-to-end operation of the system has been proven to the satisfaction of Mentor, Trapeze, and Chapel-Hill and signed off on the next phase will proceed.

System Roll-out Phase

The goal of the system roll-out phase is to complete the implementation of the mobile data system. This phase consists of the following sequence of events:

- Mentor will ship the remaining in-vehicle hardware to the communications provider, who will then proceed with the remaining hardware installations.
- Mentor personnel will provide roll-out support while remaining units are brought on-line to monitor communications and deal with any issues that may arise.

Upon successful completion of system roll-out to all parties' satisfaction, and the elimination of any outstanding issues, a system sign-off will be circulated.

System Acceptance Phase

For a period of sixty (60) days following the system sign-off Mentor will provide engineering support for the system free of charge. This phone support is limited to the hours of 8:00 AM to 5:00 PM MST from Monday to Friday (excluding statutory holidays). This support does exclude any system modifications as defined in the "Ongoing Support" section of this document.

G. Mobile Data System Costs

All pricing quoted is in US dollars, does not include any applicable taxes, and is FOB Calgary.

Note: all radio shop support figures assume the city radio shop could be sub-contracted for \$320/day. Higher city rates and/or the use of a private radio shop would require adjustments to the Radio Shop Support fees listed herein.

Radio System Evaluation Phase

	ITEM	Unit Price	Quantity	Total
1	Engineering - On-site*	\$5,000	1	\$5,000
2	Radio Shop Support (Set-up, Training)	\$320/day	5	1,600
	Total			\$6,600

*Includes travel and living expenses.

Pilot / Roll-out Phase

	ITEM	Unit Price	Quantity	Total
1	Express Plus MDT	\$1,200	8	\$9,600
2	MDT Cabling	\$69	8	552
3	Express Plus MCC	\$1,895	2	3,790
4	MCC Install Kit	\$150	2	300
5	XGate Software License	\$1,400	1	1,400
7	XGate PC (pre-configured)	\$3,950	1	3,950
8	Engineering - On-site (per week)*	\$5,000	1	5,000
9	Engineering - Project Management	\$2,500	1	2,500
10	Radio Shop Support (Installation)	\$320/day	8	2,560
	Total			\$27,390

*Includes travel and living expenses.

Firmware Customization

Mentor Engineering will supply any customization to the MDT firmware at a rate of \$90/hr.

GPS Option

	ITEM	Unit Price	Quantity	Total
1	Internal 8 Channel GPS Receiver*	\$495	8	\$3960
2	Radio Shop Support-Installation	\$320/day	1	320
	Total			\$4,280

*Includes direct mount antenna and cabling. Internal receivers must be ordered at the same time as the MDTs.

Odometer Monitoring Option*

	ITEM	Unit Price	Quantity	Total
1	Odometer Transducer & Cabling	\$89	8	\$712
	Total			\$712

*Installation has not been included in this quote. Chapel-Hill's local vehicle maintenance provider would be the most qualified to complete this task. Mentor will provide support with regards to identifying the proper installation procedure.

Extended Warranty Fees

The Express MDT comes with a two (2) year warranty and the MCC a three (3) year warranty. The following extended warranty pricing covers MDT repair/replacement and return shipping. The extended warranty fee would be added to the base price of the MDT at the time of purchase.

Extended Warranty	Price
First 2 Years of Warranty	included
3 Years Total Warranty	\$72
4 Years Total Warranty	\$145
5 Years Total Warranty	\$220

On-going Support

This section outlines the various levels of ongoing support and services available from Mentor Engineering over the lifetime of the mobile data system.

Support Plans

Following the sixty day acceptance phase Mentor will provide XGate Maintenance and phone support to the customer under a yearly plan. The support plan includes XGate Maintenance, a yearly fee that provides the customer with an unlimited warranty on the XGate software package, as well as 50 hours of phone support.

Plan	Hours of Phone Support	Cost
XGate Maintenance	25 hrs./year	\$2,495/year

Each call will be subject to a 20 minute minimum charge. Mentor will track the amount of support time already used that calendar year and update Chapel-Hill upon request.

Mobile Data System Analysis

Mentor Engineering will also provide scheduled system analysis services to customers. These services include:

- analyzing the customer's communication logs
- presenting the customer with a graphical representation of the results
- providing a written summary of the results and any recommendations to increase system efficiency

Mentor will provide these system analysis services under any of the following plans:

Plan	Schedule	Cost
Level One	Upon Request	\$550
Level Two	Biannually	\$950/year
Level Three	Quarterly	\$1350/year

Note: These charges are based on the system operating over a single communications network. Additional communications networks would require a separate analysis to be done.

System Modifications

Mentor will supply system modifications to the customer on a per project basis. Modifications to the system should occur after the system has been running for a reasonable period of time and should take into account input from the vehicle operators. Mentor will quote the following services on a per project basis.

- changes to the communications network
- changes to the host software (dispatching application)
- CAPP file modifications

H. Options

Optional Equipment

Mentor can supply any of the following peripheral devices and equipment installation products:

Options*	Price/Unit
Trimble SVeeSix GPS Receiver (external)	\$600
Card Swipes - Magnetic	\$135
Mobile Printers	\$595
Pedestal Mount - telescopic + swivel adjust	\$95
Custom Overlays	\$950 + \$12/MDT

*Introduction of some optional peripherals may require MDT firmware customization.