

# NAVAL POSTGRADUATE SCHOOL MONTEREY, CALIFORNIA



19980102 175

## THESIS

**SPREADSHEET DECISION SUPPORT MODEL  
FOR TRAINING EXERCISE MATERIAL  
REQUIREMENTS PLANNING**

by

Arthur M. Tringali

June 1997

Principal Advisor:  
Associate Advisor:

Paul J. Fields  
Kevin R. Gue

Approved for public release; distribution is unlimited.

**DTIC QUALITY INSPECTED 2**

# REPORT DOCUMENTATION PAGE

Form Approved OMB No. 0704-0188

Public reporting burden for this collection of information is estimated to average 1 hour per response, including the time for reviewing instruction, searching existing data sources, gathering and maintaining the data needed, and completing and reviewing the collection of information. Send comments regarding this burden estimate or any other aspect of this collection of information, including suggestions for reducing this burden, to Washington Headquarters Services, Directorate for Information Operations and Reports, 1215 Jefferson Davis Highway, Suite 1204, Arlington, VA 22202-4302, and to the Office of Management and Budget, Paperwork Reduction Project (0704-0188) Washington DC 20503.

1. AGENCY USE ONLY <i>(Leave blank)</i>	2. REPORT DATE June 1997	3. REPORT TYPE AND DATES COVERED Master's Thesis	
4. TITLE AND SUBTITLE <b>SPREADSHEET DECISION SUPPORT MODEL FOR TRAINING EXERCISE MATERIAL REQUIREMENTS PLANNING</b>		5. FUNDING NUMBERS	
6. AUTHOR(S) Tringali, Arthur M.			
7. PERFORMING ORGANIZATION NAME(S) AND ADDRESS(ES) Naval Postgraduate School Monterey CA 93943-5000		8. PERFORMING ORGANIZATION REPORT NUMBER	
9. SPONSORING/MONITORING AGENCY NAME(S) AND ADDRESS(ES)		10. SPONSORING/MONITORING AGENCY REPORT NUMBER	
11. SUPPLEMENTARY NOTES The views expressed in this thesis are those of the author and do not reflect the official policy or position of the Department of Defense or the U.S. Government.			
12a. DISTRIBUTION/AVAILABILITY STATEMENT Approved for public release; distribution is unlimited.		12b. DISTRIBUTION CODE	
13. ABSTRACT <i>(maximum 200 words)</i> This thesis focuses on developing a spreadsheet decision support model that can be used by combat engineer platoon and company commanders in determining the material requirements and estimated costs associated with military training exercises. The model combines the business practice of Material Requirements Planning and the commercial spreadsheet software capabilities of Lotus 1-2-3 to calculate the requirements for food, consumable supplies, petroleum products, and major end items of equipment. The demand for these materials are directly dependent on the quantities of personnel and equipment items to participate in the training exercise. The model takes into consideration existing on-hand and on-order supplies and materials, and the anticipated effects of lead times in determining the net requirement and time period an item must be placed on order to ensure its availability for the training exercise. The capability of this model to enhance planning through what-if analysis and the investigation of variability and stochastic influence on the model is also explored. The add-in program Crystal Ball is used to simulate the effects of lead time variability on the model.			
14. SUBJECT TERMS Spreadsheet Decision Support Model, Training Exercise Material Requirements Planning		15. NUMBER OF PAGES 172	
		16. PRICE CODE	
17. SECURITY CLASSIFICATION OF REPORT Unclassified	18. SECURITY CLASSIFICATION OF THIS PAGE Unclassified	19. SECURITY CLASSIFICATION OF ABSTRACT Unclassified	20. LIMITATION OF ABSTRACT UL

NSN 7540-01-280-5500

Standard Form 298 (Rev. 2-89)  
Prescribed by ANSI Std. Z39-18 298-102



Approved for public release; distribution is unlimited.

**SPREADSHEET DECISION SUPPORT MODEL FOR TRAINING  
EXERCISE MATERIAL REQUIREMENTS PLANNING**

Arthur M. Tringali  
Major, United States Marine Corps  
B.S., Virginia Military Institute, 1984

Submitted in partial fulfillment  
of the requirements for the degree of

**MASTER OF SCIENCE IN MANAGEMENT**

from the

**NAVAL POSTGRADUATE SCHOOL**

**June 1997**

Author:

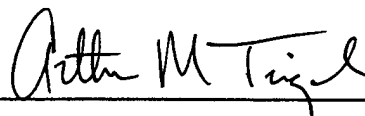

Arthur M. Tringali

Approved by:

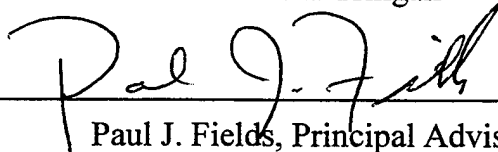

Paul J. Fields, Principal Advisor



Kevin R. Gue, Associate Advisor

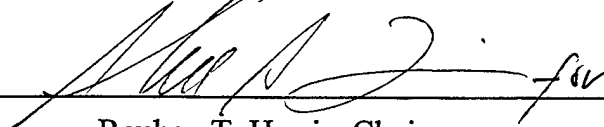

Reuben T. Harris, Chairman,  
Department of Systems Management



## ABSTRACT

This thesis focuses on developing a spreadsheet decision support model that can be used by combat engineer platoon and company commanders in determining the material requirements and estimated costs associated with military training exercises. The model combines the business practice of Material Requirements Planning and the commercial spreadsheet software capabilities of Lotus 1-2-3 to calculate the requirements for food, consumable supplies, petroleum products, and major end items of equipment. The demand for these materials are directly dependent on the quantities of personnel and equipment items to participate in the training exercise. The model takes into consideration existing on-hand and on-order supplies and materials, and the anticipated effects of lead times, in determining the net requirement and time period an item must be placed on order to ensure its availability for the training exercise. The capability of this model to enhance planning through what-if analysis and the investigation of variability and stochastic influence on the model is also explored. The add-in program Crystal Ball is used to simulate the effects of lead time variability on the model.



## TABLE OF CONTENTS

I.	INTRODUCTION .....	1
	A. BACKGROUND .....	1
	B. OBJECTIVE .....	3
	C. SCOPE, ASSUMPTIONS AND LIMITATIONS .....	5
	D. METHODOLOGY .....	6
	E. ORGANIZATION OF THE STUDY .....	7
II.	BACKGROUND INFORMATION .....	9
	A. SPREADSHEETS AS A DECISION SUPPORT TOOL .....	10
	1. Introduction .....	10
	2. Basic Functions .....	11
	3. Enhanced Capabilities .....	13
	B. MATERIAL REQUIREMENTS PLANNING .....	14
	1. Introduction .....	14
	2. Basic Objectives and Logic .....	15
	3. System Inputs .....	17
	4. System Outputs .....	19
III.	MODEL DEVELOPMENT .....	21



A.	THE PROBLEM .....	21
1.	Combat Engineer Battalion .....	22
2.	Exercise MRP Calculations Under the Manual Method ..	29
B.	THE MODEL .....	32
1.	System Requirements .....	33
2.	Scenario .....	33
3.	MRP Spreadsheet Templates .....	35
IV.	APPLICATION AND ANALYSIS .....	53
A.	APPLICATION .....	53
1.	Case Study .....	53
2.	Exercise MRP Calculations Under the Spreadsheet Decision Support Model .....	55
3.	MRP II and Material Costs .....	74
4.	Stochastic Influence on Lead Time Variability .....	74
C.	ANALYSIS .....	78
1.	Strengths .....	79
2.	Weaknesses .....	80
V.	SUMMARY, CONCLUSIONS AND RECOMMENDATIONS .....	81
A.	SUMMARY AND CONCLUSIONS .....	81
B.	RECOMMENDATIONS .....	82

APPENDIX A.	ENGINEER PLATOON PRODUCT STRUCTURE .....	83
APPENDIX B.	TEMPLATE FORMULAS .....	101
APPENDIX C.	CAX 8-93 TEMPLATES .....	131
APPENDIX D.	CRYSTAL BALL SUMMARY REPORTS .....	147
LIST OF REFERENCES	.....	153
INITIAL DISTRIBUTION LIST	.....	155



## LIST OF FIGURES

Figure 1	a). Spreadsheet Entries and b). As Actually Displayed (After Sounderpandian, 1989) .....	12
Figure 2.	Explosion of Bill of Materials (After Heizer and Render, 1993 and Orlicky, 1975) .....	16
Figure 3.	Combat Engineer Battalion Organization .....	22
Figure 4.	Bill of Material/Inventory Status Record (BOM/ISR) Template ..	37
Figure 5.	Training Exercise/Deployment Information (TE/DI) Template ...	38
Figure 6.	Class I: Subsistence Calculations Template .....	39
Figure 7.	Class III: Petroleum, Oils and Lubricants Calculations Template .....	40
Figure 8.	Part 101: Combat Engineer Platoon (reinforced). A typical upper level template for the final product (After Sounderpandian, 1989) .....	42
Figure 9.	Part 308: Machine Gun, 7.62mm, M60E3. A typical intermediate level part template. (After Sounderandian, 1989) .....	44
Figure 10.	Part 601: Cleaning, Lubricating, Presrvative. A typical lower level part template. (After Sounderpandian, 1989) .....	46
Figure 11.	Table of Organization Report .....	48
Figure 12.	Equipment Density List Report .....	49
Figure 13.	Bill of Consumable Materials Report .....	51
Figure 14.	Planned Orders Release Report .....	52
Figure 15.	CAX 8-93 Training Exercise/Deployment Information (TE/DI) Template .....	57

Figure 16.	CAX 8-93 Part 101: Combat Engineer Platoon (reinforced). Upper level template for take final product. (After Sounderpandian, 1989) .....	58
Figure 17.	CAX 8-93 Class I: Subsistence Calculations Template .....	59
Figure 18.	CAX 8-93 Part 502: Meal, Ready to Eat and Part 503: Hot Meals Bill of Materials/Inventory Status Record Template .....	60
Figure 19.	a). CAX 8-93 Part 502: Meals Ready to Eat Lower Level Template. (After Sounderpandian, 1989) .....	61
Figure 19.	b). CAX 8-93 Part 503: Hot Meals Lower Level Template. (After Sounderpandian, 1989) .....	62
Figure 20.	CAX 8-93 Part 410: Engineer Tape a). Bill of Materials/ Inventory Status Record Template. b). Lower Level Template. (After Sounderpandian, 1989) .....	64
Figure 21.	CAX 8-93 a). Petroleum, Oils and Lubricants Calculation Template, Bulk Fuel-Diesel. b). Part 511: Diesel Fuel Bill of Materials/Inventory Status Record .....	66
Figure 22.	CAX 8-93 a). Part 506: Antifreeze Bill of Material/Inven- tory Status Record. b). Petroleum, Oils and Lubricants Calculation Template, Packaged Petroleum Products .....	67
Figure 23.	CAX 8-93 Part 316: Tool Kit, Pioneer, Engineer Squad a). Bill of Materials/Inventory Status Record. b). Lower Level Template .....	69
Figure 24.	CAX 8-93 Table of Organization Report .....	70
Figure 25.	CAX 8-93 Equipment Density List Report .....	71
Figure 26.	CAX 8-93 Bill of Consumable Materials Report .....	72
Figure 27.	CAX 8-93 Planned Orders Release Report .....	73

Figure 28. CAX 8-93 Consumable Materials Cost Estimate Report ..... 75

Figure 29. CAX 8-93 Part 413: DET Cord Connectors a). Bill of  
Materials/Inventory Status Record Template. b). Lower  
Level Template. (After Sounderpandian, 1989) ..... 77



## I. INTRODUCTION

### A. BACKGROUND

The pressures of fiscal constraints and limited resources, combined with the demands of regional conflict, humanitarian support and other non-traditional "operations other than war" have created great challenges in supporting America's smaller, more highly mobile and technologically advanced forces. The second issuance of the Department of Defense (DoD) Logistics Strategic Plan within a year's time frame, while accounting for progress toward past goals and reflecting the changes in defense priorities, remains consistent with the previous philosophy of emphasizing logistics performance and flexibility, both now and in the future.

The greatest challenge faced by DoD logisticians in the 1990s is to reengineer the logistics system to support modern warfare and peacetime training requirements with precise and agile logistics response. In doing so, DoD and its components will need to break away from the old paradigm of "buying, holding, repairing and moving a massive logistics presence to prevent support failure," to embrace a new one that reliable, flexible, cost effective and prompt logistics support and services within a lean infrastructure. (Kaminski, 1995)

To achieve higher performance with fewer assets, targeted exactly to the point of need, DoD logistics managers must have timely and accurate information about the status of materials and other support assets. The logistics processes and planning tools they use will need to be more efficient than they currently are. Shorter lead times and better management information systems will be essential to improve customer confidence and to anticipate change and variability, rather than just reacting to it. Better and faster information will also be critical to shortening cycle times,



reducing risk to both DoD and its suppliers, optimizing expenditures and resources, and reducing investment in potentially obsolete inventories. (Kaminski, 1995)

DoD is moving towards this new paradigm through selective investments in technology, modernization of management information systems, training, process and product reengineering and employing the most successful commercial and government sources available. Since the Department's logistics system is part of the national industrial and logistics capability, rebalancing of public and private sector logistics methods is essential to ensure best value and better results are obtained for the scarce resources DoD expends. To achieve world class capabilities while reducing the cost of its logistics system, Defense Department officials are committed to fielding standardized and modern logistics business systems, and to implementing the most successful business practices available today.

The scope of adopting commercial business systems and practices includes Material Management, Distribution, Transportation, Maintenance, Medical Logistics, and Management Information Systems (MIS). DoD and its components plan to achieve optimal logistics decision-making capability by developing common processes and standardized definitions, and incorporating modern MIS, decision support and source data acquisition technology. The objective is to incrementally implement these business processes and technological improvements to baseline standard systems on a continual basis starting in Fiscal Year 1997. As with most strategic decisions, this is a long-term plan that will stretch well into the next century.

Congruent with the incorporation of successful business systems and practices are several short term "tactical decisions" and plans that can be implemented immediately on the operating unit level within the DoD. For example, scheduling, inventory management, quality control, and maintenance and reliability tactics contribute significantly to creating the competitive advantages enjoyed by commercial

organizations. These techniques can also be applied to assist the DoD logistician in analyzing the problems and making the decisions he faces everyday. This thesis examines how the implementation of one such business tactic will improve logistics decision making and planning on the unit level within DoD, specifically at the operational level of the Marine Corps combat engineer company and the engineer platoon.

## **B. OBJECTIVE**

U.S. Marine Corps combat engineer battalions, each consisting of three combat engineer companies of three engineer platoons, provide close combat engineer support to the Marine division and its infantry regiments and battalions. Within the framework of the Marine Air Ground Task Force, mutually supporting relationships are established between engineer companies and infantry regiments, and similarly between engineer platoons and infantry battalions. On any given day, engineer units can be planning for or conducting training exercises with their infantry counterparts. Potentially, the combat engineer battalion's engineer platoons can be pulled in nine separate directions to support the requirements of their respective infantry battalions. To ensure that scarce resources and limited finances are optimized, the combat engineer battalion must be able to plan the logistical requirements of these multiple exercise taskings in an efficient manner.

No two training exercises generate the same logistical requirements. However, there are many requirements that are common to all exercises. Based on the anticipated mission and exercise requirements, engineer units are task-organized and reinforced with additional personnel, vehicles and equipment. Dependent relationships exist between the number of personnel for an exercise and the types of vehicles and equipment and the consumable supplies and materials needed to support them.

A Bill of Materials (BOM) and associated costs are developed for each exercise from the unit's Table of Organization (T/O) and Equipment Density List (EDL). The BOM is used to assess the gross exercise material logistics requirements against any on-hand and on-order inventories to calculate the net exercise requirements to be placed on order. The procedure is time consuming, done manually with a calculator, and is based on rules of thumb and the personal experience of those individuals involved in the calculations. Additionally, the procedure must be done early enough in the planning process to account for the different lead times of materials. Moreover, this tedious procedure must be repeated to accommodate any changes in personnel or equipment prior to the exercise. Material Requirements Planning (MRP) is a successful business "tactic" based on the dependent demand relationship of components to a finished product. As a computer-based production and inventory planning and control system, MRP provides a potential solution to this dilemma.

The Marine Corps recently acquired a software package capable of handling the calculations involved in Material Requirements Planning. Lotus SmartSuite, including the spreadsheet program Lotus 1-2-3, is now the software standard for the Marine Corps. Unfortunately, its unique and powerful computing abilities are not always fully utilized. Spreadsheets, however, have significant capability allowing managers to develop user-friendly models, conduct simulation analysis, maintain data, and graphically represent results.

Utilizing the abilities of spreadsheets to implement MRP could provide the Marine logistician with a readily available tool to facilitate the planning of material requirements to support multiple exercise taskings. By automating this procedure, Bills of Materials and their cost estimates can be built in a more timely and efficient manner, ensuring material availability for exercises while potentially reducing

inventory levels and saving money. The merging of these two decision support tools, spreadsheets and MRP, into one integrated system is the objective of this research.

### **C. SCOPE, ASSUMPTIONS AND LIMITATIONS**

This thesis develops a spreadsheet model to assist combat engineer platoon and company commanders, and battalion S-4 logistics officers in the logistical planning involved with military training exercises. Emphasis is placed on establishing dependent demand relationships based on a projected Table of Organization for personnel and an Equipment Density List, and incorporating Material Requirements Planning techniques in the military planning process. This thesis also explores the capabilities of the model to enhance planning through what-if and sensitivity analysis of the stochastic influence of variability in material lead times.

Lotus 1-2-3 was selected for this study since it has already been adopted as the standard spreadsheet program of the Marine Corps. It offers a variety of functions, macro languages and extensive graphical capabilities. It is relatively easy to learn and offers programs to translate its code into other spreadsheet formats. Crystal Ball, an add-in package to Lotus 1-2-3, provides enhanced capabilities for conducting what-if and probabilistic sensitivity analysis and can be used in to explore the effects of lead time variability.

It is recognized that spreadsheet programming may not be the most efficient way to model this particular problem. Many specialized and custom developed MRP programs are available commercially, and in some cases would likely be superior to a simple spreadsheet program developed by an individual manager. However, the trade off is a considerable investment in time and costs associated with professional software development and implementation for computations that can be obtained almost as efficiently with an MRP-based spreadsheet program. In fact, spreadsheets offer some significant benefits over specialized software. Besides being less

expensive, spreadsheet programs require less of an investment in time. They are easier to develop and install, and take a shorter time to learn, use, and troubleshoot. Additionally, the spreadsheet program is more flexible than the professional software, making it easier to add, modify and delete features. Finally, Lotus 1-2-3 is readily accessible throughout the entire Marine Corps and can be found at all commands, bases and stations. The intent behind this research is to utilize those assets that are immediately available to the Marine logistics manager, and that can help him with the planning decisions that he confronts on a daily basis.

The problem analyzed in this thesis is one that has been personally experienced by the author on numerous occasions. It was selected to illustrate the overall value of merging current business practices, namely Material Requirements Planning, with the capabilities of spreadsheet programming, using Lotus 1-2-3, to support logistics decision making. Although this problem is narrowly defined and of a specific nature, the techniques applied in this research could be applicable to other scenarios.

#### **D. METHODOLOGY**

This research relies heavily on existing techniques and procedures associated with MRP and the implementation of spreadsheet programs. The model developed was adapted from those presented in existing literature. Additional data concerning the development and application of spreadsheets, decision support models, and the techniques involved with Materials Requirements Planning were found in texts and periodicals. The data necessary for determining the dependent demand relationships between the materials and personnel and equipment were collected from past military exercises and through interviews with combat engineer officers. Rules of thumb and heuristics were established for the relationships between items where dependent demand relationships were not apparent.

## **E. ORGANIZATION OF THE STUDY**

Chapter II discusses background information, the basis from which this model is developed. The unique capabilities that spreadsheets provide logistics managers and decision-makers, as well as the Material Requirements Planning techniques that can be used to develop the logistics requirements for military training exercises, are identified.

The decision support model is developed in Chapter III. Initially, the background of the problem is discussed, as well as the planning factors and considerations for determining the various classes of supplies and materials required of a reinforced combat engineer platoon supporting an infantry battalion. Then, using Lotus 1-2-3 and adapting MRP techniques to spreadsheet programming, a model is created that generates an exercise Bill of Materials, assesses gross requirements and on-hand and on-order quantities to calculate the net material requirements, and anticipates the effects of various lead times in placing those supplies and materials on order.

Chapter IV applies the model and analyzes its effectiveness in assisting the logistics manager and decision-maker. Advantages and disadvantages of the model, as compared with the traditional method of exercise material logistics planning are addressed. The ability of the model to support logistics planning and decision making in a stochastic environment, namely variation and uncertainty of lead times, is also explored.

Chapter V summarizes the findings of this study and provides concluding remarks on the strengths and limitations of the model and its overall relevance to the logistics decision maker.



## II. BACKGROUND INFORMATION

Logistics decision makers operate in complex environment created by a dynamic world, rapidly changing in an era of limited resources and constrained finances. In response, the field of logistics is evolving into a science with implications and applications reaching far beyond those traditionally associated with supporting military operations. Once concerned only with moving supplies and equipment, logisticians now decide what materials are required, what quantities are needed, when they will be needed, and how long it will take to acquire them. These and a variety of other decisions are necessary to ensure timely, effective operation and to keep down excess inventory costs, prevent waste, and efficiently utilize available resources. As a result, logisticians are looking for new tools and methods to assist them in making appropriate decisions. (Goeller, 1995)

Old methods, such as performing pencil and paper computations and relying on intuition and experience alone, are no longer sufficient to provide efficient solutions to the problems logistics managers now face. At the quickened pace of the world today, the time required for manual calculations could render a decision worthless, not to mention the increased potential for error involved with such calculations. Likewise, judgmental errors caused by intuitive experience-based decision making alone can greatly contribute to inappropriate logistics decisions being made (Goeller, 1995). Unfortunately, these older methods are the ones that are commonly used by Marine Corps combat engineer battalions to determine the material requirements for their training exercises. To overcome these potential sources of error, this work proposes the use of spreadsheet programming and Materials Requirements Planning (MRP) to assist the combat engineer and logistics decision maker.



## **A. SPREADSHEETS AS A DECISION SUPPORT TOOL**

### **1. Introduction**

Initially developed during the early days of the personal computer revolution, spreadsheet programs continue to be one of the most powerful and versatile computer applications produced. Based on the vertically and horizontally ruled accounting documents of the same name, spreadsheets were originally designed to automate the accountant's drudgery of manual calculations and transcribing numbers. By simplifying this process of calculating numbers along columns and rows, errors have been reduced and countless hours of work have been eliminated. As a result, spreadsheet programs quickly gained acceptance by accountants and financial managers. By applying the power of the computer to remove the drudgery of manual calculations, financial managers can analyze problems that were once prohibitively labor intensive. Spreadsheets provide a wide variety of applications and useful tools to support the financial manager in his decision making (Goeller, 1993).

The continual development and improvement of spreadsheets and the powerful personal computers on which they run have created an opportunity that is changing the way all managers conduct business and make decisions. Spreadsheets empower their users, allowing them to search for solutions to the problems they encounter every day. Managers no longer have to rely on others to provide the analytical tools necessary for effective decision making and problem solving (Plane, 1994). The ability to manage data, carry out vast quantities of calculations, develop models, conduct analysis, and graphically depict the results is within the grasp of all decision makers. These capabilities, present in current spreadsheets, extend far beyond those available only a few years ago (Vazsonyi, 1993).

Spreadsheets are the simplest, most user-friendly, yet powerful general purpose tool for conducting basic numerical analysis and working with mathematical models

(Vazsonyi, 1993). The result is that many more managers and decision makers have become more quantitatively proficient. As the logistics field continues to evolve as a science, logisticians will be able to exploit the basic functions and enhanced capabilities of the spreadsheet in support of logistics decision making.

## **2. Basic Functions**

The building blocks of spreadsheets are the vast array, literally thousands, of cells created by intersecting columns and rows. Individual cells derive their names from their corresponding columns and rows. For instance, the cell at the intersection of column D and row 5 would be referred to as D5, and so on. It is within these cells that the user can enter either text, a number, or a formula. By adjusting the widths of columns and heights of rows, the spreadsheets inherent format allows the manager to create huge databases to manage numbers and text. However, "it is the formulas behind the cells that make the spread sheet come alive" (Sounderpandian, 1989). They tell the computer to calculate the contents of cells or ranges of cells, and then display the result. The program allows the computer to do so automatically.

A spreadsheet displayed in Figure 1(a) contains all three types of entries: text such as "gross requirements" etc. have been entered in cells A1 through A5; the numbers 100, 70, and 10 have been entered in cells D1, C2, and C3 respectively; and the formulas "+C2+C3" and "+D1-D4" have been entered in cells D4 and D5. What the spreadsheet user actually sees in cells D4 and D5 are the results of the calculation of the formulas. These formulas tell the computer to add the contents of cells in one case and subtract the contents of cells in the other and then display the results as shown in Figure 1b. If the numbers in cells C2 and C3 are changed, for instance to 50 and 5, the formula will automatically recalculate and change the values of cell D4 to 55 and cell D5 to 45. (Sounderpandian, 1989)

a).	A	B	C	D
1	Gross Requirements			100
2	On Hand			70
3	On Back Order			10
4	Total Available			+C2+C3
5	Net Requirements			+D1-D4

b).	A	B	C	D
1	Gross Requirements			100
2	On Hand			70
3	On Back Order			10
4	Total Available			80
5	Net Requirements			20

**Figure 1. a). Spreadsheet Entries and b). As Actually Displayed (After Sounderpandian, 1989)**

By intentionally changing the values of cells the user can perform “What if...” analysis, a valuable and versatile characteristic of spreadsheet programs. For example, what if the values of the on-hand and on-order quantities change? What will be the effect and impact on the system? The user can analyze the system and display the results by simply changing the numbers in the appropriate cells. “What-if” analysis allows the user to change the system’s inputs or independent variables and study the effect on the outcomes or dependent variables.

In addition, advances in graphics allow users to illustrate the results of analyses by creating clear graphs and informative charts. As the saying goes “one picture is worth a thousand words”, so it is true for the various types of charts and maps the user can easily produce using spreadsheets. By giving the user a graphic image of what is going on, this function aids the user in analyzing complex relationships, in making decisions and in communicating the results to other decision makers.

Ninety percent of all spreadsheet operations involve opening the spreadsheet and making meaningful entries of text, numbers and formulas in the various cells. The remaining ten percent, the harder part, involves understanding the enhanced capabilities of the spreadsheet, learning shortcuts, knowing the many functions available, and developing an ability to construct models to solve problems (Sounderpandian, 1989).

### **3. Enhanced Capabilities**

The basic functions of spreadsheets allow the user to model simple mathematical problems. However, it is the enhanced capabilities and specialized functions that increase the flexibility of the spreadsheet. Built in formulas, linkable worksheets, and add-in programs offer the logistician the tools to evaluate complex situations and optimally solve problems that would otherwise be difficult to assess.

Spreadsheet programs, such as Lotus 1-2-3, have hundreds of built in functions to assist the user's analysis and problem solving. These include the traditional mathematical functions (e.g., logarithmic, exponential, factorial, trigonometric, and the normal, poisson, gamma, beta distributions), but also logical, command, data base, financial, text, lookup, random numbers and macro control functions as well. By storing the algorithms of the functions instead of actual numbers, computers rapidly calculate values and immediately react to changes in input values. Managers and engineers are now free from looking up numbers in tables and charts, an error prone process in itself. Built in formulas and functions have created new and unlimited opportunities for spreadsheet users, providing capabilities beyond those available to most individuals. (Vazsonyi, 1993)

To increase their versatility and extend their capabilities, current spreadsheet programs have multiple interrelated worksheets, each one a separate spreadsheet in itself. This collection of interlinked spreadsheet pages can be saved as a single file.

Linking speeds up calculations and keeps all the spreadsheets up-to-date, reflecting the latest changes to input variables. This capability is extremely useful for organizing the types of programs that require a large number of linked spreadsheets, such as Materials Requirements Planning. (Sounderpandian, 1994)

Finally, other computer applications are available that “add-in” to the spreadsheet to enhance its capabilities. Crystal Ball is one such program that facilitates the application of probability analysis to decision making with spreadsheets. Past spreadsheet analysis typically used values, without out any consideration as to the likelihood of other values occurring. Now, however, Crystal Ball allows the user to include probability distributions to describe input variables.

To run a probabilistic analysis, a spreadsheet of the item of interest is prepared. Assumptions about stochastic input variables are then defined by selecting the distribution and the parameters of that distribution. Dependent output variables are defined as forecast cells, and after the selected number of iterations are run, the simulation results can be analyzed and graphically displayed. By conducting sensitivity analysis on spreadsheet data, the quality of information is enhanced since the risk associated with a decision can be assessed. This can often lead to significantly different decisions being taken. (Sangster, 1994)

Programs involving complex branching logic can be difficult to implement, but fortunately for logisticians, Materials Requirements Planning does not involve complex logic and is readily implementable in spreadsheet programs. (Sounderpandian, 1989)

## **B. MATERIAL REQUIREMENTS PLANNING**

### **1. Introduction**

Material Requirements Planning is a computer-based production and inventory planning and control system employed primarily for items in which the final product consists of an assembly of component parts. (Taylor III, 1993) “The precise timing

of materials flows to meet production requirements is the principle behind materials requirements planning.” (Ballou, 1992) MRP has been successfully used in many manufacturing corporations since the early 1960s. Since that time MRP has experienced surges in popularity, brought on by advances in computer technology. During the 1970s, compact powerful mini-computers available at affordable prices and programs that mechanized the process brought MRP within the grasp of smaller businesses. (Pillifant, 1982) Continued technological advances in personal computers and spreadsheet programs have contributed to yet another resurgence in MRP popularity. Now, even the smallest firms, and firms that find commercial MRP packages too expensive, have a low cost do-it-yourself alternative; they can develop their own MRP system with current spreadsheet programs (Sounderpandian, 1989).

## **2. Basic Objectives and Logic**

The basic objective of MRP is to accurately determine material requirements over a certain demand period, allowing timely and correct purchasing action to be taken to ensure that the right materials are on hand exactly when required. All MRP systems are designed to ensure the availability of components and materials for timely assembly of the final product by coordinating manufacturing plans, delivery schedules, and purchasing activities. (Taylor III, 1993) The logistics of this can be very complex and difficult when the number of items involved is large. Automating this process offers benefits not possible with a manually calculated system. Lower inventory levels, reduced material shortages, less time spent expediting, increased productivity and improved product quality are potential results. These all contribute to significant savings and are attractive objectives in a resource constrained environment. Above all else, MRP has a basic logic that allows production activities to be proactively scheduled and effectively planned ahead. (Pillifant, 1982)

The basic logic of an MRP system is that a predetermined number of parts, supplies and materials go into an end product. That is, the demand pattern for these supplies and materials can be derived directly from end product demand. (Ballou, 1992) Dependent demand exists when the requirements for one component are dependent upon the demand for another. For instance, the demand for truck tires is directly dependent upon the number of finished trucks to be produced. "Exploding" the finished product breaks it down into its component parts and subassemblies, which in turn are further broken down until all materials making up the finished product are accounted for. Figure 2 shows how a product is exploded to reveal the requirements for each component. For each final product A produced, two units of

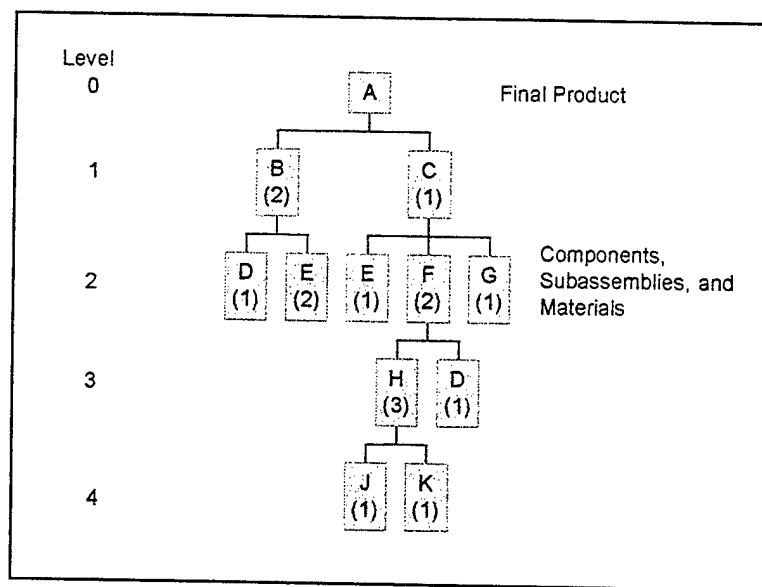

**Figure 2. Explosion of Bill of Materials (After Heizer and Render, 1993 and Orlicky, 1975)**

component B and one unit component C are required. Likewise, each unit of B requires one unit of D and two units of E. In similar fashion, all the supplies and materials required to produce product A can be identified. Therefore, once the

demand for a final product can be forecasted, the quantities for all the components of that item may be determined. (Heizer and Render, 1993) A schedule can be created by identifying when each component will be needed in the production process and the lead time necessary to receive that component. "By offsetting the request for parts, materials, and supplies by the lead time for them, the end product requirements can be met at the time they develop." (Ballou, 1992) In this way, an MRP system can determine exactly how much of and when each component should be ordered.

### **3. System Inputs**

To effectively plan when materials shall be required, exactly what those materials will be, and in what quantities, an MRP system requires three major inputs: a master production schedule, a bill of material, and an inventory status record.

#### ***a. Master Production Schedule***

The master production schedule outlines the production plans of the organization by specifying what products are to be made and when. It provides the basis from which the timing of material requirements are determined. The computerized MRP system combines the scheduled output in the master schedule with lead times to determine the individual time-phased requirements for components, subassemblies and materials. Exploding the master production schedule in this way influences the process of ordering material and issuing the material to the shop floor in a manner that ensures the timely completion of finished products. (Taylor III, 1993) The master production schedule answers the question of when materials are needed. However, it doesn't answer what all those materials will be. This answer is provided by the bill of material.

#### ***b. Bill of Material***

The bill of material is a level-by-level breakdown of all component, subassembly and raw material quantities required to make the products identified in



the master production schedule. It contains information on the components used in each product's construction, and the sequence in which they are assembled to make the final product. The BOM informs the MRP system about each item and identifies the quantity used in each application, its part number, and description. By combining the BOM with the Master Production schedule, gross material requirements can be determined simply by multiplying the number of end items by the quantities of components necessary to produce that end item. (Taylor III, 1993) For example, in Figure 2 if the demand for product A is 20 units, then 40 units of component B and 20 units of component C will be required. In turn, 40 units of component B will require 40 units of D and 80 units of E, and so on. In this fashion, the gross material requirements needed to support the desired output as identified in the master production schedule can be determined. However, "MRP systems meet their objectives by computing net requirements for each item, time phasing them, and determining their proper coverage...by correctly placed shop orders and purchase orders." (Orlicky, 1975) The information needed to convert gross requirements into net requirements is found in the inventory status record.

*c. Inventory Status Record*

Inventory status records contain the on-hand and on-order status for all items in inventory, plus information on lead times and order lot-sizes for all components. For the MRP system to work, good inventory management and accurate records are essential. To prevent overstocking and over ordering, the net material requirements are computed by subtracting the available inventory, those assets according to the inventory status record which are on-hand or on-order and not allocated to a particular job, from the gross requirements. The result is that only the correct quantities of materials needed to support the BOM according to the time frame established in the master production schedule are obtained.

#### 4. System Outputs

MRP provides answers to several basic logistics questions. It determines what to order, how much to order and when to order. Simply put, MRP is a method of achieving the age-old goal of logisticians: To get the right material to the right customer in the right quantity at the right time in the right condition. (Pillifant, 1982) To do so, net requirements are time phased to meet the completion dates contained in the master production schedule. (Taylor III, 1993) The timing of shop orders for components produced internally and purchase orders for those sourced from suppliers is determined by offsetting the order receipts by their lead time. In this manner, the right materials at the right quantities are produced at the right time.

The outputs of an MRP system can be customized to the needs of a particular organization. Many different user-defined reports can be generated by using the information contained in the files that comprise the MRP system. (Pillifant, 1982) Typically, the basic computer output of the MRP system is planned order releases in the form of purchase orders to vendors to match the needs of production operations. These releases indicate the timing and quantity of the orders. (Taylor III, 1993)

By augmenting the data from the MRP system, with other resource data, substantial applications and outputs beyond scheduling and inventory management can be achieved. Manufacturing Resource Planning (MRP II) is a newer term that is an extension of the basic principles of the standard MRP system. (Heizer and Render, 1993) MRP II is concerned with all resources consumed in the manufacture of the end item, not just with the material requirements in the process. For example, by augmenting MRP with material cost data the product costing function of the organization can be automated. The material costs of executing a production plan can be forecast with greater accuracy. MRP II includes other capabilities as well, expanding the concept of MRP to one of total resource planning. (Pillifant, 1982)



### **III. MODEL DEVELOPMENT**

When the demand for one item is directly related to the demand for another item a dependent relationship exists. For any given product, all component parts and materials required to make that product are dependent demand items. These items are listed in a bill of material (BOM). The required quantities of components are computed once the demand for the final product has been forecasted. For example, manufacturers derive the gross demand for dependent materials from the number of finished goods scheduled for production. The net requirements are determined after subtracting current inventories and on-order items. When the lead times to obtain dependent items are considered, time phasing and scheduling of material requirements can be achieved as well. By quantitatively modeling these dependent demand relationships, Materials Requirements Planning is being successfully used across a wide variety of commercial applications. In fact, wherever schedules for dependent demand items are known or can be established these techniques can and should be applied. (Heizer and Render, 1993)

#### **A. THE PROBLEM**

The United States Marine Corps uses dependent demand analysis on a regular basis. This is most apparent within the combat engineer battalion. Besides developing BOMs for the construction projects they undertake, combat engineers also use BOMs as part of their planning process to document the supplies and materials needed to support training exercises and deployments. In both cases, dependent demand analyses are used to compute the BOMs and plan the material requirements. Unfortunately, combat engineers only apply these techniques manually, forgoing an opportunity to duplicate within the Marine Corps the MRP successes experienced in private industry.

# 1. Combat Engineer Battalion

## a. Organizational Structure

The combat engineer battalion (CEB) is a separate battalion located within each of the Marine Corps' three active duty and one reserve divisions. It consists of a headquarters and service (H&S) company, an engineer support company, and three combat engineer companies as depicted in Figure 3. The H&S company provides the battalion with command and control functions, and communications support to subordinate elements of the battalion. The engineer support company has an equipment support platoon, a utilities platoon and a motor transport platoon that

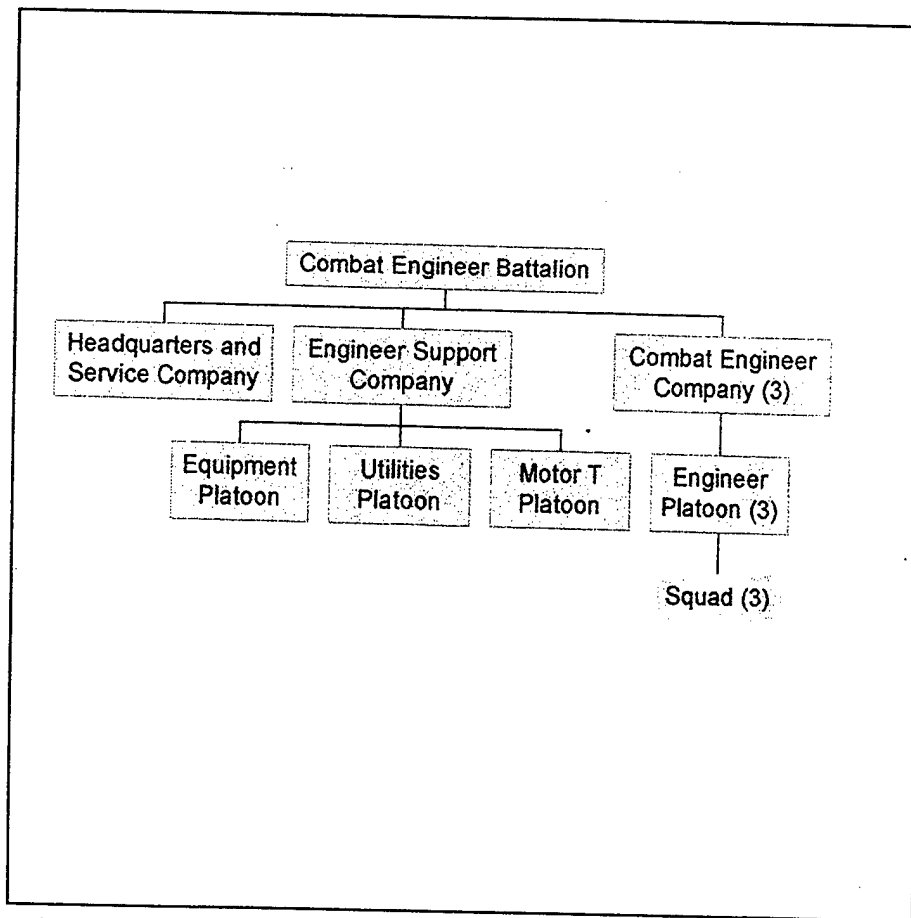

Figure 3. Combat Engineer Battalion Organization

provide personnel and equipment support to reinforce the three combat engineer companies. To perform its mission, each combat engineer company consists of three combat engineer platoons, which consist of three 11-man engineer squads.

*b. Mission and Employment*

The CEB's primary mission is to enhance the mobility, countermobility, and survivability of the Marine division through close combat engineer support. Likewise, the combat engineer company's mission is to provide that same support to meet the essential requirements of an infantry regiment and its associated elements during combat operations. The CEB and its engineer companies accomplish this mission by performing the following tasks: (Department of the Navy, 1992)CK REF

- Supporting intelligence collection by conducting engineer reconnaissance, and augmenting reconnaissance missions with requirements for engineer intelligence;
- Planning, organizing and coordinating assault breaching of nonexplosive and explosive obstacles;
- Employing assault bridge systems, conducting expedient repairs of existing bridges, and constructing expedient bridges;
- Providing temporary repairs to existing roads as well as constructing and maintaining combat roads and trails;
- Planning, organizing, and coordinating construction of nonexplosive and explosive obstacle systems, to include construction of obstacles requiring engineer equipment or skills, and
- Performing demolition missions beyond the ability of the supported unit.

To accomplish these tasks, the CEB normally employs one reinforced combat engineer company in direct support of an infantry regiment. This relationship requires the combat engineer company to give priority to the support required by the

infantry regiment, without having to be attached to or placed under the command of the infantry unit. This permits the engineer battalion to maintain efficient control of its subordinate units while maximizing the battalion's productivity, and also spares the infantry regiment the additional administrative and logistical burdens of supporting an attached unit. However, this requires the combat engineer battalion to plan and provide for the logistics requirements of its engineer companies. Since engineer companies only possess essential motor transport assets and basic hand-employable tool chests, sets and kits, they are usually reinforced with additional personnel and equipment as required by the mission. In turn, the engineer company must ensure the logistics requirements of its three reinforced combat engineer platoons are met, since they provide support to each of the regiment's three infantry battalions.

The reinforced platoon is the smallest combat engineer unit capable of conducting sustained operations. Engineer squads are not normally assigned to maneuver units, except for short duration under pressing circumstances. Therefore, the combat engineer company normally operates under the decentralized control of the platoon commanders while providing widely separated support to individual infantry battalions throughout the parent regiment's area of operations. This allows the engineer company commander to act as an advisor to the infantry regimental commander, to coordinate the entire engineer effort in his area, and to ensure that the engineer platoons have adequate supplies and materials to perform their mission. Considering the geographical area an infantry regiment and its battalions are responsible for, ensuring the right logistics support is provided at the right time and to the right location is no easy feat. Peace time training requirements do not make this task any easier to accomplish.

Marine units train in peacetime in the same manner in which they would be employed in war. As such, the combat engineer battalion establishes supporting

relationships between its companies and platoons and their respective infantry counterparts. Whenever an infantry regiment or battalion conducts a training exercise or goes on deployment, its supporting engineer company or platoon will be attached, accompanying the infantry unit for the duration of the exercise. The engineer company will most likely find its three platoons pulled in separate directions to support their infantry battalions. This creates a challenge for the company commander to conduct the planning and effectively manage the logistical requirements of his subordinate units. When examined at the engineer battalion level, three engineer companies and nine engineer platoons supporting a variety of training and exercise requirements further complicates this situation. To ensure that the engineer units are adequately supported with supplies and materials, combat engineers have been performing manual analyses that are similar to the MRP technique used in the private sector.

*c. Exercise Support*

Combat engineer units routinely deploy with and train alongside their infantry counterparts. Operational commitments are planned for and scheduled far in advance of their actual execution. The Marine Corps uses the Training Exercise Employment Plan (TEEP) to document these exercises and deployments 12 to 24 months ahead of time. The TEEP is the equivalent of a master production schedule. It tells exactly what is to be done, when it will be done, and which units are going to do it. Based on the TEEP and other factors such as the anticipated mission, the operating environment, and the time span of the exercise, the engineer battalion can plan for and determine what "final products" it needs to produce.

As missions vary, so do the characteristics of the operations involved in them. The personnel and equipment requirements for an exercise involving mechanized, highly mobile operations conducted in a desert environment differ



greatly from those required of a mostly foot-mobile mountain warfare exercise. Likewise, exercises conducted in extreme environmental conditions, such as cold-weather training, place added demands for personnel, equipment, materials and supplies. Finally, the time span of an exercise acts as a multiplier when determining what requirements are needed. Exercises of longer duration have greater material requirements than those lasting only a short time.

Reinforced combat engineer companies and platoons are task-organized with equipment and personnel, tailoring their capabilities to meet these anticipated requirements. In the MRP context, the engineer company in its sum total of materials, supplies, equipment and personnel can be viewed as one of the end items or final products that the CEB produces. The engineer platoon is one of the company's primary components, or it can be a separate product in itself. A Table of Organization (T/O) and Table of Equipment (T/E) respectively defines the unit's personnel and equipment capabilities, or the component parts and subassemblies required to make the final product. When combined with the consumable supplies and materials required to support the unit's personnel and equipment, this listing of parts can be likened to the bill of material used in MRP.

The T/O serves two functions. It describes the organization of the unit and provides an actual listing of the authorized personnel allocation. For each and every exercise, a T/O is specifically developed, reflecting the actual organization and personnel that are to participate. A typical combat engineer company is broken down into platoons, which in turn are broken down into squads and a heavy equipment/motor transport section. This continues all the way down until the numbers of Marines that make up the various occupational specialties within the unit are identified. From the number of platoons, squads, and individual Marines, the demand for many items of equipment and materials can be determined. For example, the

number of mine detectors, demolition sets, carpenter's chests, pioneer kits, and crew-served weapons required, will depend directly on the number of engineer squads participating. Likewise, the total number of Marines will determine requirements for Meals-Ready-to-Eat (MREs), hot meals, cleaning supplies, toilet paper, etc. Hot meal requirements then drive the quantities of paperware, napkins, and plastic utensils needed, as well. This process continues until all materials that make up the final product are identified.

The T/E is the other document that assists in identifying these items. The T/E identifies all the equipment a unit requires, the total of equipment which is both physically on hand and on requisition. The T/E is primarily an inclusive listing of all the major end items of equipment that are inherent to the unit.

Based on the T/E and any additional equipment reinforcement the unit receives, an Equipment Density List (EDL) is developed for each and every training exercise, reflecting the actual equipment to be used. Like the T/O, the EDL is also exploded into "subcomponents" and "subassemblies," which in turn drive the demand for supplies and materials. Equipment items like mine detectors, demolition sets, carpenter's chests, pioneer kits, and crew-served weapons produce requirements for supplies such as batteries, electrical tape, nails, screws, rope, weapons's lubricant, and bore patches. Likewise, within the engineer equipment and motor transport "subcomponents," specific quantities of heavy engineer equipment (such as bulldozers, backhoes, etc.) and motor transport vehicles derive the demand for items such as petroleum, oils, lubricants, rags, dry sweep, repair parts, etc. Therefore, in much the same manner as commercial MRP, combat engineer logistics managers use dependent demand analysis to determine the bill of material and supply requirements to support the personnel and equipment required for military training exercises.

The Marine Corps' definition of the BOM however, is inconsistent with that used in MRP applications. A BOM in the Marine Corps is defined as the consumable supplies and materials derived from the personnel and equipment requirements in the T/O and EDL. This represents only a small portion of the sum total of personnel, equipment, supplies, and materials required to produce the final product. However, when the BOM is combined with the T/O and EDL, these three documents comprise the bill of material that is analogous to that normally used in MRP. Together the T/O, EDL, and BOM reflect gross requirements; that is, the total quantity of component parts, subassemblies and materials comprised in a combat engineer company or platoon.

From the gross material requirements, combat engineers manually calculate net requirements, after taking on-hand inventory stocks and the scheduled delivery dates for incoming orders into consideration. Net requirements are the minimum quantities of supplies and materials to be placed on order. As in MRP, the accuracy of these calculations are directly tied to the accuracy of the supply records. Equally as important to knowing what to order, is knowing when to order, to ensure these items are available when they are needed. Only then can it be certain that the final product can be assembled and produced in a timely manner.

Engineer decision makers use administrative and logistics milestones and deadlines for the deployment or exercise to determine when materials should be assembled or sourced through the appropriate supply channels. Specific dates for mobile loading and embarkation, personnel and equipment inspections, and assembling all personnel and equipment together contribute to the calculation of lead times for these items. Lead times of supplies and materials placed on order are further evaluated, ensuring that orders are placed in a timely manner to avoid unnecessary waiting and missed training opportunities.

## **2. Exercise MRP Calculations Under the Manual Method**

The determination of material requirements for training exercises is based on a variety of elements: reference data, planning factors, heuristic rules of thumb, personal experience, and dependent demand relationships. Of the ten classes of supply, the following lend themselves to MRP and dependent demand analysis:

### ***a. Class I: Subsistence Calculations***

Class I supplies include those food items upon which the exercise force subsists. During training exercises, Marines are usually provided a combination of cold and hot meals. Packaged operational rations in the form MREs make up the cold meals. They are designed for feeding individual Marines when the tactical situation is unstable and cooking facilities cannot be used. MREs also allow Marine units to conduct training in the field and on various ranges away from the field mess or chowhall. During training exercises, Marines are customarily fed MREs for the noon meal each day during the training period and for all three meals each day during the actual field exercise. Hot meals in the form of "A" or "B" rations make up the other two daily meals (breakfast and dinner) during the pre-exercise and post-exercise training periods.

Dependent demand analyses are used for planning the requirements for hot meals and MREs. The T/O provides the information for determining the amount of food items needed by the unit. The time span of the training exercise is also used. Simple calculations, done manually with hand calculators, determine the demand for each type of ration. It is the product of number of personnel multiplied by the number of meals required per day multiplied by the number of days of the exercise. For example, a 100 man reinforced engineer company conducting a two week (14 day) training exercise, of which four days are a field exercise, generates the following demands:

- MREs: (100 Marines) (1 meal/day) (10 days) + (100 marines) (3 meals/day) (4 days) = 2200 MREs

- Hot meals: (100 Marines) (2 meals/day) (10 days) = 2000 hot meals

In similar fashion, quantities of paper plates, bowls and cups and plastic forks, knives, and spoons are derived from the number of hot meals. In this example, 2000 of each are required. If this engineer company is conducting its own exercise then it would source these items for itself. However, if the company is attached to an infantry unit for an exercise, then it would be required to provide this information by a required milestone date to ensure that adequate support is provided.

***b. Class II: Consumable Supplies Calculations***

Class II supply items consist of consumable components of organization tool sets and kits, as well as consumable administrative and housekeeping supplies and equipment. Items such as engineer tape in squad pioneer kits, screws within carpenter kits, electrical tape and detonating cord connectors in demolition kits, and chemical light sticks in minefield marking kits are regularly consumed during the course of training exercises. The quantities of these items that each kit requires are specified in SL-3 extract inventory sheets. By combining this information with information in the T/O and the T/E, total requirements for consumable supplies and components can be determined.

For example, if a combat engineer company is actually deploying with two of its three engineer platoons, according to the T/O only six engineer squads will be participating. Based on the T/E, each squad requires a squad pioneer kit, which in accordance with the SL-3 rates three rolls of engineer tape. In total, this company will require 18 rolls of engineer tape as it departs for the training exercise. If 13 are on-hand then a net requirement of five will be ordered in time to ensure delivery prior to the exercise.

Similarly, the requirements for other consumables that are components of the unit's chests, sets and kits are determined. Consumables also take the form of administrative and housekeeping supplies and equipment. By specifying what quantities are required per Marine, squad, or platoon, total quantities can be determined as demonstrated above.

*c. Class III: Petroleum, Oil, and Lubricants (POL) Calculations*

Class III supplies include petroleum fuels, lubricants, hydraulic and insulating oils, coolant and antifreeze compounds. Requirements are expressed in terms of bulk products for diesel fuel and gasoline, and packaged products for oils, greases, and antifreeze. The EDL provides the information on the amount of equipment in which fuel is required. Material requirements are determined by using additional planning factors: consumption rates expressed in terms of gallons per hour and usage rates of expected hours per day for each specific type of motor transportation vehicle or engineer equipment. Based on the number of days, bulk fuel requirements can easily be determined by taking the product of the number of a specific type of vehicles multiplied by gallons per hour multiplied by the number of hours per day. For example, if a company has deployed with 8 Highly Mobile Multi-purpose Wheeled Vehicles (HMMWV), and these vehicles use diesel fuel at the rate of 1.7 gal/hr, an average of 8 hr/day for the 14 day exercise, then the demand for diesel fuel would be:

$$(8 \text{ HMMWV})(1.7 \text{ gal/hr})(8\text{hr/day})(14 \text{ days}) = 1523.2 \text{ gallons of diesel fuel.}$$

Similar calculations are done for all the other vehicles and equipment, the results of which are combined to determine the total bulk fuel requirements for the exercise.

All motor transport and engineer equipment items to participate on the exercise are reviewed for scheduled maintenance actions. Depending on the maintenance action to be performed, an estimate for packaged POL products can be determined. This becomes a factor for longer duration exercises where maintenance actions cannot be deferred. The calculations are carried out in the same manner.

*d. Class VII: Major End Items Calculations*

Class VII supplies are the major end items of equipment (i.e., tanks, vehicles, weapons systems, etc.) that are ready for their intended use. The information in the T/E provides the unit's allowance for these particular items. By using the T/O to determine the specific numbers of platoons, squads, and individual marines participating in the exercise, with the information in the T/E, the requirements for Class VII supplies can be determined. For example, each engineer squad has an allowance of a squad pioneer kit, a demolition kit, and a mine detector. Therefore, if three squads deploy, three of each item will be required. Likewise, the number of platoons drives the numbers of similar items of equipment. By using these dependent relationships, a base quantity of Class VII supplies is established. By taking into consideration external factors such as mission and environment other items may be added or deleted to tailor the final product to the requirements specified in the TEEP.

**B. THE MODEL**

The idea of using spreadsheet programming for material requirements planning is not new. Procedures and techniques that have been successfully applied in commercial MRP applications have been adapted to match the developing capabilities of spreadsheet programs. In a paper on MRP spreadsheet implementation (Sounderpandian, 1989), a detailed example is offered to demonstrate the practicality of developing a low cost do-it-yourself alternative to commercial MRP packages that can be used by small business firms. The model presented in Sounderpandian's paper

is used in this research as the starting point for developing an MRP spreadsheet decision support model applicable to the Marine Corps combat engineering support problem.

### **1. System Requirements**

The spreadsheet software used in this model is Lotus 1-2-3 Release 5 for Windows, running on an IBM compatible personal computer (PC). As the standard spreadsheet application and computer configuration for the Marine Corps, both were chosen to facilitate the implementation of this research within the Fleet Marine Force. As a component of SmartSuite, Lotus 1-2-3 can be found at all commands, bases and stations. It is already familiar to many Marines, and is easy to learn for those who have not used it.

To conduct the probabilistic sensitivity analysis of lead time variability on the model, Crystal Ball version 3.0, an add-in program to either Lotus 1-2-3 or Microsoft Excel was used. By incorporating probability into the analysis the quality of the information is enhanced immensely Crystal Ball allows the decision maker to go beyond the basic single cell, discrete "what-if" analysis inherent in spreadsheet programs and allows for a "multiple cell probability based approach." Through simulation, stochastic variables or assumptions can be defined by selecting expected data values, choosing distributions and defining the parameters of the distributions. The dependent variables are defined as forecast cells. By selecting the number of iterations to run, the type of analysis, and the graphical outputs, Crystal Ball enables the decision maker to judge the influence and effect of each assumption on the forecasted variables. (Sangster, 1994)

### **2. Scenario**

As the smallest combat engineer unit capable of conducting sustained operations, the reinforced platoon is also the most likely to be tasked with supporting the



various training requirements within the Marine division. Accordingly, engineer platoons frequently deploy and participate in numerous military training exercises. This requires the combat engineer company commander to simultaneously plan for and manage multiple engineer platoon taskings. Conflicting demands and competition for limited resources in personnel, equipment, and supplies require efficient materials requirements planning and coordination.

The model was specifically developed to support the decision making ability of combat engineer company commander in managing the logistics requirements of his platoons in support of military training exercises. The model focuses on the reinforced engineer platoon as a final product in a MRP environment. The platoon's personnel, equipment, and supplies are treated as subassemblies and component parts of the final product. The dependent relationships that make up the product structure of the reinforced engineer platoon and its subcomponent parts are shown in Appendix A.

*a. Assumptions*

In support of the model scenario the following assumptions are made:

- When a combat engineer platoon is task-organized, it is reinforced with personnel, equipment and supplies, most of which are common to a majority of the training situations, missions, and environments likely to be encountered. These common materials are the focus of the MRP application in this model.
- Only the exact quantities of materials required to support the training exercise will be placed on order. This model will use a lot-for-lot, lot sizing technique to determine planned order release quantities which take any existing on-order and on-hand quantities into account.
- Acting as a Master Production Schedule, the TEEP sets deployment dates from which subsequent milestone events and deadlines are determined.

These will influence when material orders are processed to ensure delivery on the required date.

- To support MRP the company commander must have good inventory management and asset visibility. Supply inventory status sheets must be accessible, accurate, and up to date to include knowledge of on-order items and their appropriate lead times.
- Each reinforced platoon is produced as a unique final product tailored to a specific TEEP exercise requirement.
- A Bill of Material reflecting all equipment, materials and supplies is developed for each final product (platoon). All subcomponents and assemblies are treated as parts and identified with part numbers.

***b. Limitations***

This model addresses only those items most commonly used across the broadest spectrum of exercises, missions, and environmental considerations. Other items of concern, including special environmental equipment and other supply classes, are not addressed. These items would still require manual calculation of their material requirements.

"A workbook is a collection of spreadsheets, usually linked among themselves, which are bound together as a book and saved as a single file" (Sounderpandian, 1994). Since the CEB produces final products that are uniquely tailored and task-organized, only one specific customer requirement or TEEP line number is addressed per workbook. If a reinforced engineer company is required, it will be built upon the reinforced platoons as its main subcomponents.

**3. MRP Spreadsheet Templates**

Each spreadsheet is a separate worksheet, which can be thought of as a page within a workbook. When the workbook is open, all of the worksheets are active and automatically kept up to date when a new variable is specified. A workbook consist-

ing of six worksheets is used to organize this decision support model. Within the worksheets, there are numerous templates used to input specific variables and data into the model, and to display the results of the MRP calculations. Formulas for all the templates within the workbook are located in Appendix B.

*a. Input Templates*

(1) **Bill of Materials/Inventory Status (BOM/ISR) Template.** As illustrated in Figure 4, this template is divided into two major parts, the first of which calculates the gross requirements of the bill of materials. The first column identifies the component part number and name, and allows the user to input the specific dependent demand relationships to the parent part number. In some cases, as with the Class I Subsistence items and the Class III POL items, the spreadsheet automatically links the specific quantity from another template that has calculated the demand relationship quantity. The second and third columns respectively display the results of applying formulas that compute the subtotals per parent part number and the overall gross requirements for each subcomponent assembly or part.

The second part of the BOM/ISR template stores the inventory status data for each part number. This data includes the lead time required for sourcing the item, the on-hand quantities of any undedicated parts that can be applied to satisfy the requirements of this exercise.

(2) **Training Exercise/Deployment Information (TE/DI) Template.** This template is shown in Figure 5. Dates for the different periods of the training exercise are recorded in the top portion. Formulas automatically calculate the corresponding number of days for each period and display the results. This information is in turn linked to other templates which require a specific time period against which usage rates can be applied to determine the gross exercise requirements. The bottom portion of the template provides a location for recording milestone dates and

Bill of Materials/ Inventory Status Record					
Component Part No./ Part Name	Quantity/ Parent Part No./ Part Name	Sub Total	Gross Reqmt.	Lead Time	On Hand Quantity
101	Engineer Platoon		1	0	0
201	Platoon Headquarters				
	1 per 101 Engr Plt		1	0	0
202	Engineer Squad				
	3 per 101 Engr Plt		3	0	0
203	Engr Equip./Motor T Section				
	1 per 101 Engr Plt		1	1	0
301	Engr Officer/SNCO (1302/1371)				
	3 per 201 Plt Hqtrs		3	0	0
302	Can, Water				
	5 per 201 Plt Hqtrs		5	0	8
303	Combat Engineer (1371)				
	2 per 201 Plt Hqtrs	2			
	10 per 202 Engr Sqd	30			
			32	0	0
304	Night Vision Sight, AN/PVS-4				
	1 per 201 Plt Hqtrs		1	0	0
305	Night Vis. Goggles, AN/PVS-5A				
	2 per 201 Plt Hqtrs		2	0	0
306	Radio Operator (2531)				
	1 per 201 Plt Hqtrs		1	0	0
307	Radio Set, PRC-77				
	3 per 201 Plt Hqtrs	3			
	0 per 202 Engr Sqd	0			
			3	1	0

Figure 4. Bill of Material/Inventory Status Record (BOM/ISR) Template

<b>Training Exercise/Deployment Information</b>			
<u>Period Dates</u>	<u>From</u>	<u>To</u>	<u>No. Days</u>
Training Ex. Period	11/25/96	12/11/96	17
Advance Party	11/22/96	11/24/96	3
FEX	12/07/96	12/09/96	3
Rear Party	12/12/96	12/13/96	2
<u>Milestone Events</u>		<u>Date</u>	
Departure		11/25/96	
Mobile Load Equipment		10/05/96	
Tool Chests, Sets, Kits Inspect.		10/14/96	
HE/MT LTI		10/14/96	
Personnel Inspection		11/02/96	
All supplies received		11/23/96	
Equipment Attached		10/25/96	
Personnel Attached		11/24/96	
Submit T/O Strength		07/12/96	
Submit EDL		06/07/96	
Submit Class I Requirements		07/12/96	
Submit Class II Requirements		06/07/96	
Submit class III Requirements		06/07/96	

**Figure 5. Training Exercise/Deployment Information (TE/DI) Template**

deadlines associated with the training exercise or deployment. These are used as required delivery dates against which the lead times can be applied.

(3) **Class I: Subsistence Calculations Template.** This template, shown in Figure 6, allows the user to specify the combination of MREs and hot meals during the different periods of the training exercise. Based on the number of days in column one, formulas within columns three and four calculate the subtotal for each type of meal per each type of training day. The gross requirement per individual is totaled below each column and is linked to the BOM/ISR template to

identify the specific dependent demand relationship for these parts needed to determine their overall gross requirements.

<b>Class I: Subsistence Calculations per individual</b>					
Type Day	No. Days	Number of Meal per Day		Total MRE	Total Hot
		MRE	Hot Meals		
Travel to Exercise	0	0	0	0	0
Training Days	14	1	2	14	28
FEX first day	1	3	0	3	0
FEX days	1	3	0	3	0
FEX last day	1	2	1	2	1
Travel from Exercise	0	0	0	0	0
			Total	22	29

**Figure 6. Class I: Subsistence Calculations Template**

(4) **Class III: Petroleum, Oils and Lubricants Calculations Template.** Figure 7 shows that this template is divided into three parts: Bulk fuel-Diesel, Bulk fuel-Mogas, and Packaged Petroleum Products. The first two bulk fuel sections are arranged in a similar manner. The first two columns provide descriptive information about the equipment item. Column one provides the TAMCN and total exercise requirement for that item, while column two gives the nomenclature and the training period in which it to be used. Into the third column the user inputs the number of equipment items or vehicles that will be used during the training period. Column four contains the consumption rate planning factor expressed in

Class III: Petroleum, Oils and Lubricants Calculations							
Bulk Fuel - Diesel							
TAMCN	Nomenclature	# Vehicles	Gal/Hr	Hrs/Day	No. Days	Gallons	Total
B2460	Tractor, Full-Trk, Angle Blade, Case 1150E						
	Advance Party	0	4	0	3	0	
	Training Period	0	4	0	14	0	
Total	1	1	4	4	3	48	
	FEX	1	4	4	3	48	
	Rear Party	0	4	0	2	0	
	Total						48
B2462	Tractor, Full-Trk, Medium, D7G						
	Advance Party	0	6	0	3	0	
	Training Period	1	6	1	14	84	
Total	1	1	6	2	3	36	
	FEX	1	6	2	3	36	
	Rear Party	0	6	0	2	0	
	Total						120
B2482	Tractor, All Whl Dr, w/ Attach., SEE						
	Advance Party	0	4	0	3	0	
	Training Period	1	4	1	14	56	
Total	2	2	4	4	3	96	
	FEX	2	4	4	3	96	
	Rear Party	0	4	0	2	0	
	Total						152
B2567	Tractor, Rubber Tire, Artic. Str, TRAM						
	Advance Party	0	4	4	3	0	
	Training Period	1	4	1	14	56	
Total	1	1	4	2	3	24	
	FEX	1	4	2	3	24	
	Rear Party	0	4	4	2	0	
	Total						80
D0209	Power Unit, Front, 12.5-ton, MK48						
	Advance Party	0	16.66	3	3	0	
	Training Period	1	16.66	1	14	233.24	
Total	1	1	16.66	4	3	199.92	
	FEX	1	16.66	4	3	199.92	
	Rear Party	0	16.66	5	2	0	
	Total						433.16
D1059	Truck, Cargo, 5-ton, M923						
	Advance Party	0	11.5	3	3	0	
	Training Period	2	11.5	2	14	644	
Total	1	2	11.5	5	3	345	
	FEX	2	11.5	5	3	345	
	Rear Party	0	11.5	2	2	0	
	Total						989
D1072	Truck, Dump, 5-ton, M929						
	Advance Party	0	11.5	2	3	0	
	Training Period	1	11.5	1	14	161	
Total	1	1	11.5	3	3	103.5	
	FEX	1	11.5	3	3	103.5	
	Rear Party	0	11.5	2	2	0	
	Total						264.5
D1158	Truck, Utility, 1.25-ton, HMM/UV						
	Advance Party	0	1.7	2	3	0	
	Training Period	3	1.7	1	14	71.4	
Total	4	3	1.7	5	3	76.5	
	FEX	3	1.7	5	3	76.5	
	Rear Party	0	1.7	2	2	0	
	Total						147.9
Bulk Fuel - Mogas							
TAMCN	Nomenclature		Gal/Hr	Hrs/Day	No. Days	Gallons	Total
B1830	Saw, Chain, One-Man Portable						
	Advance Party	0	0.5	0	3	0	
	Training Period	0	0.5	0	14	0	
Total	3	3	0.5	2	3	13.5	
	FEX	3	0.5	2	3	13.5	
	Rear Party	0	0.5	0	2	0	
	Total						13.5
Packaged Petroleum Products							
NSN	Nomenclature	Unit Issue	Qty.	Req. Qty			
6810-00-249-9354	Electrolyte	GI	0	3			
6850-00-181-7929	Anti-Freeze	1-GI Bt	15	0			
6850-00-181-7933	Anti-Freeze	5-GL CN	3	3			
6850-00-181-7940	Anti-Freeze	55-GI Dr	0.272727	0			
9150-00-189-6727	Lube Oil, 10wt	1-Qt Cn	40	0			
9150-00-186-6668	Lube Oil, 10wt	5-GI Cn	2	2			
9150-00-191-2772	Lube Oil, 10wt	55-GI Dr	0.181818	0			
9150-00-186-6681	Lube Oil, 30wt	1-Qt Cn	40	0			
9150-00-188-9856	Lube Oil, 30wt	5-GI Cn	2	2			
9150-00-189-6729	Lube Oil, 30wt	55-GI Dr	0.181818	0			
9150-00-035-5392	Lube Oil, 90wt	1-Qt Cn	100	0			
9150-00-035-5393	Lube Oil, 90wt	5-GI Cn	5	5			
9150-00-035-5394	Lube Oil, 90wt	55 GI Dr	0.454545	0			
9150-00-190-0905	Grease, GAA	5.5-Lb Cn	1.692308	2			
9150-00-190-0907	Grease, GAA	35-Lb Cn	0.314286	0			
9150-01-053-6688	CLP	GI	0.445313	1			
9150-01-054-6453	CLP	Pt	3.5625	0			

Figure 7. Class III: Petroleum, Oils and Lubricants Calculations Template

gallons per hour. The next column allows the user to input an anticipated usage rate in hours per day for each of the designated training periods. The sixth column contains the results of formulas that calculate the number of days for each training period. Formulas within the last two columns respectively calculate the number of gallons required per each training period, and provide a net total for each type of equipment to be used. These quantities are linked to the BOM/ISR template where the gross bulk petroleum requirements are calculated.

The bottom portion of the template addresses the requirements for packaged petroleum products. The first three columns provide information about the particular products: National Stock Number (NSN), nomenclature, and the unit of issue. Based on the unit of issue, formulas in the next column pull in the gross requirements from the BOM/ISR template and determine the required quantity for each specific NSN of the product. The remaining column allows the logistics decision maker to decide which NSN and required quantity are the most economical, and input the result into the model.

*b. Upper Level Template*

Figure 8 shows the template for the final product, Part Number 101, combat engineer platoon (reinforced). The top portion is used to store the part name and number as well as the lot-for-lot order quantity and the lead time required to source and receive the part. Below that is the section which identifies the master production schedule data for the part. The outstanding exercise support requirement includes the customer, the customer order number (TEEP number), the quantity required, and the required date by which the product is due. The first two columns of this section are input by the user, while the third and fourth columns contain the formulas that pull the data from the appropriate input templates. Based on the required due date, formulas ensure that an entry is automatically made under the



Figure 8.

Part 101: Combat Engineer Platoon (reinforced). A typical upper level template for the final product (After Sounderpandian, 1989)

Part No: 101 Lot-for-Lot= 1  
 Part Name: COMBAT ENGINEER PLATOON (REIN) LT= 0 week(s)

Exercise Support Requirement:  
 Customer: IEEP No. 11/25/86  
 ZBnZ3Mar 96-007 Qty 1

Backlog	Week 1	2	3	4	5	6	7	8	9	10	11	12	Future
04-Nov	11-Nov	18-Nov	25-Nov	02-Dec	09-Dec	16-Dec	23-Dec	30-Dec	06-Jan	13-Jan	20-Jan	27-Jan	
0	0	0	0	0	0	0	0	0	0	0	0	0	0
0	0	0	0	0	0	0	0	0	0	0	0	0	0

Scheduled Return:  
 Qty 1 Due Date 12/1/86

04-Nov	11-Nov	18-Nov	25-Nov	02-Dec	09-Dec	16-Dec	23-Dec	30-Dec	06-Jan	13-Jan	20-Jan	27-Jan
0	0	0	0	0	0	0	0	0	0	0	0	0
0	0	0	0	0	0	0	0	0	0	0	0	0

On Hand 0  
 Planned Order Release 0

Remarks:

appropriate week in the right hand portion of the section. Likewise, these formulas also ensure that the Monday date of the current week will always appear under the Week 1 heading. In this manner the spreadsheet always remains current. The twelve columns to the right allow for twelve weeks or one quarter's visibility into the future.

The next portion of the template provides visibility of the planned receipt (return) of the final product upon the exercise's completion. Formulas in the first two columns automatically pull the information from the input templates, just as those in the remaining columns ensure that the dates are current and the appropriate quantity is entered. It is the next portion of the upper level template that actually identifies when the final product will be required on hand to ensure its availability in meeting its support requirements. A cell is provided to store the on-hand quantities of the engineer platoon which in almost all cases will be zero since the engineer platoons do not routinely keep a complete supply of all the component parts, and materials that they would require on-hand. The remaining columns in the on-hand row calculate the current balance of the final product. The next row in that section calculates planned order releases in accordance with the lead time and the required delivery date. It is this line of data that is in return linked to the second level parts templates in order to provide by-dates for the subassemblies and component parts. The final portion of the upper level template provides an area for the user to record any assumptions and detailed information concerning the exercise support requirement for Part Number 101.

*c. Intermediate Level Templates*

For intermediate level parts such as Part No. 308 in Figure 9 the template layout is similar to that of the upper level Part No. 101. The upper portion of the template displays pertinent information linked from the BOM/ISR: the Part No. and Part Name, the total Lot-for-Lot requirement as well as the anticipated lead time

Part No: 308 Lot-for-Lot= 2  
 Part Name: MACHINE GUN, 7.62MM, M60E3 LT= 0 week(s)

Exercise Support Requirements:		Week 1	2	3	4	5	6	7	8	9	10	11	12	Future
Backlog	Part No.	04-Nov	11-Nov	18-Nov	25-Nov	02-Dec	09-Dec	16-Dec	23-Dec	30-Dec	06-Jan	13-Jan	20-Jan	27-Jan
0	2	0	0	0	0	0	0	0	0	0	0	0	0	0
Total Requirements		0	0	0	0	0	0	0	0	0	0	0	0	0
On Hand		0	0	0	0	0	0	0	0	0	0	0	0	0
Planned Order Releases		0	0	0	0	0	0	0	0	0	0	0	0	0

REMARKS:

Figure 9. Part 308: Machine Gun, 7.62mm, M60E3. A typical intermediate level part template. (After Sounderdian, 1989)

associated with the part. The next portion of the intermediate level template identifies the total exercise support requirement based on the quantities required per parent parts as identified in the first two columns. Formulas in the remaining columns directly link the planned order releases of Part No. 201 into Part No. 308. This is a simple process since both worksheets are within the same workbook. The total requirements row below these columns contain the formulas that multiply the planned orders of the parent parts by the "Qty per" and sum them together to produce the total requirement. The remaining portions of the template are similar to those in the upper level template for Part No. 101. For every intermediate level part a spreadsheet similar to that for Part No. 308 is created.

*d. Lowest Level Template*

The template for the lowest level of parts are in turn similar to the intermediate level parts, except that they include a section that allows the user to input into the model any undedicated parts that are on-order and that can be used to satisfy the requirements for the particular exercise being planned. Figure 10 shows the template for the lower level Part No. 601. In the portion labeled Outstanding Orders the order date, the order quantity, and the due date for undedicated items are input into the first three columns. Formulas in the columns to the right automatically pull the quantity to the appropriate column in which it is due. The scheduled receipts row will then sum the column for each particular week. Formulas within the lowest level part template's on-hand row maintain the current balance, based on the initial on-hand quantity linked from the BOM/ISR and the scheduled receipt dates for any parts due in. Planned order releases for the lowest level parts take this additional information into consideration. Formulas within this row reflect the total quantity, less any on-hand and due-in items. These supplies are then ordered with sufficient lead time to ensure their arrival prior to the planned exercise. It should be noted that the warning

Part No: 601 Lot-for-Lot= 57  
 Part Name: CLEANING, LUBRICATING, PRESERV. LT= 3 week(s)

Exercise Support Requirements:		Backlog	Week 1	2	3	4	5	6	7	8	9	10	11	12	Future
Qty per	Part No.	04-Nov	11-Nov	18-Nov	25-Nov	02-Dec	09-Dec	16-Dec	23-Dec	30-Dec	06-Jan	13-Jan	20-Jan	27-Jan	
3	per 308	0	0	0	0	0	0	0	0	0	0	0	0	0	0
2	per 314	0	0	0	0	0	0	0	0	0	0	0	0	0	0
2	per 315	0	0	0	0	0	0	0	0	0	0	0	0	0	0
1	per 401	0	0	0	0	0	0	0	0	0	0	0	0	0	0
1	per 504	0	0	0	0	0	0	0	0	0	0	0	0	0	0
Total Requirements		0	0	42	0	0	0	0	0	0	0	0	0	0	ERR
		0	0	42	0	0	0	0	0	0	0	0	0	0	ERR

Outstanding Orders:

Order Date	Qty	Due Date	04-Nov	11-Nov	18-Nov	25-Nov	02-Dec	09-Dec	16-Dec	23-Dec	30-Dec	06-Jan	13-Jan	20-Jan	27-Jan
08/31/96	0	11/17/96													
09/09/96	0	11/12/96													
Scheduled Receipts			0	0	0	0	0	0	0	0	0	0	0	0	0

On Hand Quantity: 21  
 Planned Order Releases: 0

REMARKS:

O/O QUANTITIES UNDEDICATED, CAN BE USED TO SUPPORT THIS EXERCISE

Figure 10. Part 601: Cleaning, Lubricating, Preservative. A typical lower level part template. (After Sounderpandian, 1989)

messages "ERR" in the cells can be safely disregarded without harm. These messages occur because of references to blank cells to the right of the table. Formulas in the planned order releases row look out to the right the appropriate number of cells that correspond with the leadtime required for the particular part. In this figure the planned order releases for Part No. 504 are directly linked to Part No. 601. Any "ERR" warnings pulled in from this linked part will also trickle down through the model; as is the case with the planned order releases for Part No. 601. After the MRP calculations are carried through to the lowest level parts, the next step within the model is to display this information in an appropriate format.

*e. Reports*

Just as the linking of information between cells facilitated the MRP calculations, it also allows for the creation of the various reports that display the data that this model produces. These reports focus on the personnel, equipment, and consumable materials that make up the component parts and subassemblies of the combat engineer platoon. The following reports allow the engineer company commander to make informed logistics decisions in support of exercise requirements.

(1) **Table of Organization (T/O).** This report, as shown in Figure 11, displays the personnel make up of the organization by military occupational speciality (MOS) that will be assembled to support the exercise. Formulas link the information from the appropriate part numbers in the BOM/ISR input template and sum the total number of participating personnel.

(2) **Equipment Density List (EDL).** The report shown in Figure 12 accounts for equipment in the same manner in which the Table of Organization accounts for the unit's personnel. The Table of Authorized Material Control Number (TAMCN) and the nomenclature for each equipment item is

provided. The gross requirement for each item is also linked from the BOM/ISR into the quantity column of this report.

Table of Organization			
Unit	MOS	Quantity	Quantity
<u>Cbt Engr Platoon</u>		1	
<u>Platoon Headquarters</u>		1	
	1302/1371SNCO		3
	1371		2
	2531		1
<u>Engineer Squad</u>		3	
	1371		30
<u>HE/MT Section</u>		1	
	1341		2
	1345		5
	3521		2
	3531		2
	3533		1
Total			48

Figure 11. Table of Organization Report

Equipment Density List		
TAMCN	Nomenclature	Quantity
A2050	Radio Set, PRC-77	3
B0215	Bucket, Scoop, TRAM	1
B0471	Demolition Equipment, Engineer Sqd	3
B0475	Detecting Set, Mine, Metallic, AF-108	3
B0647	Forklift Attachment, TRAM	1
B1298	Line Charge Launch Kit, Trailer-Mounted	1
B1320	Minefield Marking Set	0.5
B1830	Saw, Chain, One-Man Portable	3
B2210	Tool Kit, Carpenter's, Engineer Platoon	1
B2260	Tool Kit, Pioneer, Engineer Squad	3
B2460	Tractor, Full-Track, w/ Angled Blade, Case 1150E	1
B2462	Tractor, Full-Track, Medium, D7G	1
B2482	Tractor, All Wheel Drive, w/ Attachments, SEE	2
B2567	Tractor, Rubber Tired, Articulated Steering, TRAM	1
C4436	Can, Water	5
C6490	Tool Kit, General Mechanics	4
D0209	Power Unit, Front, 12.5-ton, MK48	1
D0235	Trailer, Semi-, Lowbed, 40-ton, M870	1
D0860	Trailer, Cargo, 1.5-ton, 2-Wheel, M105	1
D0878	Trailer, Semi-, Powered, 5th Wheel, MK16	1
D1059	Truck, Cargo, 5-ton, M923	1
D1072	Truck, Dump, 5-ton, M929	1
D1158	Truck, Utility, 1.25-ton, HMMWV	4
E0915	Launcher, Assault Rocket, 83mm, SMAW	0
E0960	Machine Gun, Light, Squad, Automatic, SAW, M-249	3
E0993	Machine Gun, 7.62mm, M60E3	2
E1120	Mount, Tripod, Machine Gun, 7.62mm, M-122	2
E1151	Night Vision Goggles, Individual, AN/PVS-5A	2
E1158	Night Vision Sight, Individual Served Weapon, AN/PVS-4	1
E1250	Pistol, 9mm, Semiautomatic, M-9	3
E1441	Rifle, 5.56mm, M16A2	42
K4222	Compass	6
N6001	Binoculars	2

Figure 12. Equipment Density List Report



(3) **Bill of Consumable Materials.** Figure 13 identifies the total requirement for all consumable materials that will be needed to support the planned exercise. In this report each item is identified by its National Stock Number (NSN), nomenclature and the unit of issue. Formulas within the quantity column link information calculated within the BOM/ISR and the Class III; POL Calculations templates.

(4) **Planned Orders Release Report.** As shown in Figure 14 this report links the planned order releases for all of the parts associated with the combat engineer platoon. Based on lead times and required due dates, this report allows for timely material ordering and gathering of supplies and equipment to support exercise requirements. For the same reasons as mentioned previously, the "ERR" warning messages found in some of the cells can also be safely ignored.

Consumable Materials			
NSN	Nomenclature	Unit Issue	Quantity
1005-00-288-3565	Patches, 7.62	Pg	6
1005-00-912-4248	Patches, 5.56	Pg	-45
5790-00-816-6056	Tape, Electrical	Ro	6
6135-00-930-0030	Battery, BA-3030	Pg	1.5
6135-01-034-2239	Battery, BA-5598	Ea	12
6135-01-090-5365	Battery, BA-5567/U	Ea	9
6260-01-074-4229	Cyalume, LtStk, Yellow	Bx	1
6260-01-178-5559	Cyalume, LtStk, Red	Bx	1
6260-01-178-5560	Cyalume, LtStk, Blue	Bx	1
6810-00-249-9354	Electrolyte	Gl	8
6850-00-161-6204	Camouflage Stick	Ea	3
6850-00-181-7929	Anti-Freeze	1-Gl Bt	0
6850-00-181-7933	Anti-Freeze	5-Gl Cn	3
6850-00-181-7940	Anti-Freeze	55-Gl Dr	0
7340-00-022-1315	Fork, Plastic	Hd	14
7340-00-022-1317	Spoon, Plastic	Hd	14
7340-00-022-1316	Knife, Plastic	Hd	14
7350-00-290-0593	Plate, Paper	Bx	2
7350-00-456-2024	Cup, Paper	Bx	1
8540-00-276-7569	Napkin, Paper	Bx	1
8315-00-255-7662	Engineer Tape	Ro	3
9140-00-273-2377	Diesel Fuel	Gl	2234.56
9150-00-189-6727	Lube Oil, 10wt	1-Qt Cn	0
9150-00-186-6668	Lube Oil, 10wt	Cn	2
9150-00-191-2772	Lube Oil, 10wt	55-Gl Dr	0
9150-00-186-6681	Lube Oil, 30wt	1-Qt Cn	0
9150-00-188-9858	Lube Oil, 30wt	5-Gl Cn	2
9150-00-189-6729	Lube Oil, 30wt	Dr	0
9150-01-035-5392	Lube Oil, 90wt	1-Qt Cn	0
9150-01-035-5395	Lube Oil, 90wt	5-Gl Cn	5
9150-00-035-5393	Lube Oil, 90wt	55 Gl Dr	0
9150-00-190-0905	Grease, GAA	6.5-Lb Cn	2
9150-00-190-0907	Grease, GAA	Cn	0
9150-00-053-6688	CLP	Gl	1
9150-00-054-6453	CLP	Pt	0

Figure 13. Bill of Consumable Materials Report

Material Orders Releases Report														
Part No.	Backlog	04-Nov	11-Nov	18-Nov	25-Nov	02-Dec	09-Dec	16-Dec	23-Dec	30-Dec	06-Jan	13-Jan	20-Jan	27-Jan
101	0	0	0	0	0	1	0	0	0	0	0	0	0	0
201	0	0	0	0	0	1	0	0	0	0	0	0	0	0
202	0	0	0	0	0	3	0	0	0	0	0	0	0	0
203	0	0	0	0	1	0	0	0	0	0	0	0	0	0
301	0	0	0	0	0	3	0	0	0	0	0	0	0	ERR
302	0	0	0	0	0	0	0	0	0	0	0	0	0	0
303	0	0	0	0	0	32	0	0	0	0	0	0	0	0
304	0	0	0	0	0	1	0	0	0	0	0	0	0	0
305	0	0	0	0	0	2	0	0	0	0	0	0	0	0
306	0	0	0	0	0	1	0	0	0	0	0	0	0	0
307	0	0	0	0	3	0	0	0	0	0	0	0	0	0
308	0	0	0	0	0	2	0	0	0	0	0	0	0	ERR
309	0	0	0	0	0	0	0	0	0	0	0	0	0	0
310	0	0	0	0	0	4	0	0	0	0	0	0	0	0
311	0	0	0	0	0	0	0	0	0	0	0	0	0	0
312	0	0	0	0	0	0.5	0	0	0	0	0	0	0	0
313	0	0	0	0	0	3	0	0	0	0	0	0	0	0
314	0	0	0	0	0	0	0	0	0	0	0	0	0	0
315	0	0	0	0	0	3	0	0	0	0	0	0	0	0
316	0	0	0	0	0	3	0	0	0	0	0	0	0	0
317	0	0	0	0	0	3	0	0	0	0	0	0	0	0
318	0	0	0	0	0	3	0	0	0	0	0	0	0	0
319	0	0	0	0	0	0	0	0	0	0	0	0	0	0
320	0	0	0	0	2	0	0	0	0	0	0	0	ERR	ERR
321	0	0	0	1	0	0	0	0	0	0	0	0	ERR	ERR
322	0	0	0	2	0	0	0	0	0	0	0	0	ERR	ERR
323	0	0	0	1	0	0	0	0	0	0	0	0	ERR	ERR
324	0	0	0	1	0	0	0	0	0	0	0	0	ERR	ERR
325	0	0	0	1	0	0	0	0	0	0	0	0	ERR	ERR
326	0	0	0	0	2	0	0	0	0	0	0	0	ERR	ERR
327	0	0	0	1	0	0	0	0	0	0	0	0	ERR	ERR
328	0	0	0	1	0	0	0	0	0	0	0	0	ERR	ERR
329	0	0	0	1	0	0	0	0	0	0	0	0	ERR	ERR
330	0	0	0	1	0	0	0	0	0	0	0	0	ERR	ERR
401	0	0	0	0	0	3	0	0	0	0	0	0	ERR	ERR
402	0	0	0	0	0	1	0	0	0	0	0	0	ERR	ERR
403	0	0	0	0	0	0	0	0	0	0	0	0	ERR	ERR
404	0	0	0	0	0	0	0	0	0	0	0	0	ERR	ERR
405	0	0	0	0	0	2	0	0	0	0	ERR	ERR	ERR	ERR
406	0	0	0	0	0	0	0	0	0	0	0	0	ERR	ERR
407	0	0	0	0	0	0	0	0	0	0	0	0	ERR	ERR
408	0	0	0	0	0	0	0	0	0	0	0	0	ERR	ERR
409	0	0	0	0	0	0	0	0	0	0	0	0	ERR	ERR
410	0	0	0	0	0	0	0	0	0	0	0	0	ERR	ERR
411	0	0	0	0	0	0	0	0	0	0	0	ERR	ERR	ERR
412	0	0	0	0	0	0	0	0	0	0	0	0	ERR	ERR
413	0	0	0	0	0	0	0	0	0	0	0	0	ERR	ERR
414	0	0	0	0	0	0	0	0	0	0	ERR	ERR	ERR	ERR
415	0	0	1	4	0	0	0	0	0	0	0	0	ERR	ERR
416	0	0	1	0	0	0	0	0	0	0	0	0	ERR	ERR
417	0	0	0	5	0	0	0	0	0	0	0	0	ERR	ERR
418	0	0	1	0	0	0	0	0	0	0	0	0	ERR	ERR
419	0	0	1	0	0	0	0	0	0	0	0	0	ERR	ERR
420	0	0	1	0	0	0	0	0	0	0	0	0	ERR	ERR
421	0	0	0	1	0	0	0	0	0	0	0	0	ERR	ERR
422	0	0	0	2	0	0	0	0	0	0	0	0	ERR	ERR
501	0	0	4	0	0	0	0	0	0	0	0	0	ERR	ERR
502	492	0	0	0	0	0	0	0	0	0	0	0	ERR	ERR
503	0	0	1392	0	0	0	0	0	ERR	ERR	ERR	ERR	ERR	ERR
504	0	0	42	0	0	0	0	0	0	0	0	0	ERR	ERR
505	0	0	0	0	0	0	0	0	0	0	0	0	ERR	ERR
506	0	0	0	0	0	0	0	0	0	0	ERR	ERR	ERR	ERR
507	0	0	3	0	0	0	0	0	0	0	ERR	ERR	ERR	ERR
508	0	0	3	0	0	0	0	0	0	0	ERR	ERR	ERR	ERR
509	0	0	20	0	0	0	0	0	0	0	ERR	ERR	ERR	ERR
510	0	0	0	0	0	0	0	0	0	0	ERR	ERR	ERR	ERR
511	2234.56	2234.56	0	4	0	0	0	0	0	0	ERR	ERR	ERR	ERR
512	0	0	0	0	0	0	0	0	0	0	ERR	ERR	ERR	ERR
601	0	0	15	0	0	0	0	0	0	0	ERR	ERR	ERR	ERR
602	892	0	0	0	0	0	0	0	0	ERR	ERR	ERR	ERR	ERR
603	820	0	0	0	0	0	0	0	0	0	ERR	ERR	ERR	ERR
604	0	0	0	0	0	0	0	0	0	0	ERR	ERR	ERR	ERR
605	0	0	0	0	0	0	0	0	0	0	ERR	ERR	ERR	ERR

Figure 14. Planned Orders Release Report

## IV. APPLICATION AND ANALYSIS

### A. APPLICATION

This section deals with the practical application of the model in planning and determining material logistics in support of military training exercises. The following case study is based on the personal experience of the author and other combat engineer officers and enlisted Marines.

#### 1. Case Study

Company B, 4th Combat Engineer Battalion is a reserve combat engineer company located in Roanoke, Virginia. The company is organized in the mirror image of its active duty counterparts, with three engineer platoons consisting of three engineer squads each. Company B is also reinforced with personnel, equipment and vehicles that comprise a Heavy Equipment/Motor Transport Platoon.

The 120 reservists that make up the unit drill one weekend each month, and two weeks Annual Training (AT) each summer. With the exception of a few staff non-commissioned officers (SNCOs), all of the reserve leadership, including all of the officers, live several hours outside the Roanoke area. An active duty Inspector-Instructor Staff of 11 Marines and one Navy corpsman provide guidance, assistance and support to the reservists as they carry out their regular duties both during and in between drill weekends.

The Marine Corps Reserve attempts to conduct itself and train to the same standards expected of its active duty counterparts. In that manner, the reserve engineer battalion establishes supporting relationships between its engineer companies and the reserve infantry regiments. As these infantry units conduct their two week Annual Training exercises so do their corresponding engineer platoons or companies. Unless the regiment is training with any or all of its battalions, the

combat engineer company can expect to support three individual platoon ATs in support of the three infantry battalions. If the regimental staff is training with its subordinate units, the engineer company will most likely provide a company (-) with up to two engineer platoons and a HE/MT section. The remaining engineer platoon will conduct an AT in support of the infantry battalion not participating with the parent regiment. In either case, the reserve company commander must plan for multiple exercise requirements.

Calculating logistics requirements for reserve exercises involves the hand calculated methods used by the active duty units. Although the reserve Marines are expected to conduct their own staff planning and coordination to support these training exercises, limited time on reserve drill weekends makes this very difficult. It is often necessary for the Inspector-Instructor and his staff to provide assistance and complete the manual calculation of logistics requirements for these reserve exercises to ensure that sufficient supplies, materials and equipment are on-hand to satisfy the exercise support requirements. This was the case during the spring of 1993.

Company B, 4th Combat Engineer Battalion was tasked with supporting two AT exercises in 1993, the first one in support of the 23rd Marine Regiment for the Combined Arms Exercise (CAX) 8-93. CAXs are live-fire maneuver warfare exercises that test the unit's ability to operate under conditions that closely resemble actual combat. This particular CAX would require the bulk of Company B, with two engineer platoons and a well equipped HE/MT section. Since all CAXs take place at the Marine Corps Air Ground Combat Center located in 29 Palms, California, the monitoring of lead times is critical to ensure that vehicles and equipment shipped from the home training center, and supplies and materials ordered for the exercise arrive in time. This particular exercise took place from 26 June to 10 July 1993.

A second AT would require the remaining combat engineer platoon to participate in Mountain Warfare Training Exercise (MTEX) 1-93 with the 3rd Battalion, 25th Marine Regiment. Conducted at the Marine Corps Mountain Warfare Training Center in Bridgeport, California, this cold weather mountain exercise took place from 5 to 19 December 1993. While the personnel and equipment requirements are not as logistically intensive as the CAX, material requirements planning is still required to ensure that the Marines are properly outfitted and supplied.

The material requirements to support these AT exercises were planned and calculated manually without the aid of a MRP spreadsheet decision support model. Off and on, several reserve SNCOs and officers were dedicated to this planning effort, over the course of four to five monthly drill weekends. This time could have been spent satisfying numerous other training requirements that the Marine Corps Reserves are tasked with accomplishing. In this case, the Inspector-Instructor and his staff were eventually required to step in and add many additional man-hours to complete this manual planning effort.

## **2. Exercise MRP Calculations Under the Spreadsheet Decision Support Model**

As stated in Chapter II the strength of using spreadsheets is that they provide the tools that allow the user to model mathematical problems, evaluate complex situations, and optimally solve otherwise difficult to assess problems. These strengths are evident when applied to the planning of material requirements for training exercises. Had the spreadsheet decision support model proposed in this study been available in this case, less human resources and time spent in accomplishing the MRP would have been the likely outcome.

Based on information obtained from pre-exercise planning conferences and phone conversations, and upon his mission analysis of the exercise, the reserve engineer company commander makes those assumptions needed to determine the

general exercise support requirements for each AT. He roughly determines who will be going, which of his units and how many personnel, what equipment they will taking, and when and how long they will be participating. This is done in consideration of where and in what tactical environment the exercise will take place.

In this case, it is determined that adequate engineer support for the 23d Marine Regiment in CAX 8-93 will be a reinforced engineer company (minus). This equates to two combat engineer platoons sufficiently reinforced with motor transport and engineer equipment of a HE/MT section, all of which would fall under the command and control of the company commander and his small headquarter's element.

After these assumptions are made, a workbook for the training exercise MRP is created. This information is put into the appropriate templates so that the specific material requirements can be determined. First, the dependent demand relationships for those quantities of materials needed per parent part, and their current inventory status, the lead times and on-hand quantities are placed into the Bill of Material/Inventory Status Record template. The entire BOM/ISR for this case is provided in Appendix C. Next, the specific dates for the exercise, any training periods within the exercise, the advance and rear party dates, and any other important milestone events are recorded in the Training Exercise/Deployment Information Record template as shown in Figure 15. It should be noted that current dates that produced the correct number of days for each training period as it occurred during the exercise in 1993 were used in this model.

Finally, the customer, 23d Marines, and the TEEP number, M33018, are entered within the upper level template. Information from the BOM/ISR and TE/DI templates are linked into the upper level template also, as Figure 16 depicts. Again, the cell containing the "ERR" warning can be safely disregarded. At this point the

<b>Training Exercise/Deployment Information</b>			
<u>Period Dates</u>	<u>From</u>	<u>To</u>	<u>No. Days</u>
Training Ex. Period	12/27/96	01/12/97	17
Advance Party	12/24/96	12/26/96	3
FEX	01/07/97	01/09/97	3
Rear Party	01/13/97	01/14/97	2
<u>Milestone Events</u>		<u>Date</u>	
Departure		12/27/96	
Mobile Load Equipment		11/09/96	
Tool Chests, Sets, Kits Inspect.		10/05/96	
HE/MT LTI		10/05/96	
Personnel Inspection		12/07/96	
All supplies received		12/23/96	
Equipment Attached		09/07/96	
Personnel Attached		11/09/96	
Submit T/O Strength		09/05/96	
Submit EDL		08/01/96	
Submit Class I Requirements		08/15/96	
Submit Class II Requirements		08/01/96	
Submit class III Requirements		08/01/96	

**Figure 15. CAX 8-93 Training Exercise/Deployment Information (TE/DI) Template**



Part No: 101 Lot-for-LoI= 2  
 Part Name: COMBAT ENGINEER PLATOON (REIN) LT= 1 week(s)

Exercise Support Requirement:	Backlog	Week 1	2	3	4	5	6	7	8	9	10	11	12	Future
Customer: 1333018	Due Date: 12/27/96	11-Nov	18-Nov	25-Nov	02-Dec	09-Dec	16-Dec	23-Dec	30-Dec	06-Jan	13-Jan	20-Jan	27-Jan	03-Feb
23d Matins	QTY: 2							2						

Scheduled Return:

QTY	Due Date	11-Nov	18-Nov	25-Nov	02-Dec	09-Dec	16-Dec	23-Dec	30-Dec	06-Jan	13-Jan	20-Jan	27-Jan	03-Feb
2	01/12/97									2				

On Hand	0	0	0	0	0	0	0	0	-2	0	0	0	0	0
Planned Order Release	0	0	0	0	2	0	0	0	0	0	0	0	0	ERR

Remarks: CAX 8-93: 1996 DATES THAT PRODUCED SIMILAR 1993 TIME PERIODS WERE USED. TWO ENGINEER PLATOONS WILL SUPPORT THIS EXERCISE.

Figure 16. CAX 8-93 Part 101: Combat Engineer Platoon (reinforced). Upper level template for the final product. (After Sounderpandian, 1989)

engineer company commander is ready to address the information required to calculate the various classes of supplies and materials required for the exercise.

*a. Class I: Subsistence Calculations*

By using the template in Figure 17, the company commander specifies the number of MREs and hot meals for each period within the training exercise. Formulas calculate the subtotals for each type of meal per each type of training day.

<b>Class I: Subsistence Calculations per individual</b>					
Type Day	No. Days	Number of Meai per Day		Total MRE	Total Hot
		MRE	Hot Meals		
Travel to Exercise	1	1	1	1	1
Training Days	12	1	2	12	24
FEX first day	1	3	0	3	0
FEX days	1	3	0	3	0
FEX last day	1	2	1	2	1
Travel from Exercise	1	1	1	1	1
			Total	22	27

**Figure 17. CAX 8-93 Class I: Subsistence Calculations Template**

The gross requirement of 22 MRE's and 27 hot meals per individual is then linked to the BOM/ISR template. Figure 18 shows Part Numbers 502 MREs and 503 Hot Meals, and the dependent demand relationship of each to the numbers of personnel participating in the exercise. From this, the overall gross requirements of 1562 MREs and 1917 hot meals is easily determined.

<b>Bill of Materials/ Inventory Status Record</b>					
Component Part No./ Part Name	Quantity/ Parent Part No./ Part Name	Sub Total	Gross Reqmt.	Lead Time	On Hand Quantity
502	Meal, Ready-to-Eat (MRE)				
	22 per 301 Off/SNCO	132			
	22 per 303 1371	1100			
	22 per 306 2531	66			
	22 per 320 1341	44			
	22 per 326 3521	44			
	22 per 417 1345	88			
	22 per 421 3533	22			
	22 per 422 3531	66			
			1562	4	240
503	Hot Meals				
	27 per 301 Off/SNCO	162			
	27 per 303 1371	1350			
	27 per 306 2531	81			
	27 per 320 1341	54			
	27 per 326 3521	54			
	27 per 417 1345	108			
	27 per 421 3533	27			
	27 per 422 3531	81			
			1917	4	0

**Figure 18. CAX 8-93 Part 502: Meal, Ready to Eat and Part 503: Hot Meals Bill of Materials/Inventory Status Record Template**

This information is in turn linked to the lower level templates for both of these items to determine when the net quantity of each is to be placed on order. This is shown in Figure 19. By changing the input variables the commander can conduct a what-if analysis to study the effects of changes in the number of training days, personnel and meal types per day. The "ERR" warning messages found in Figure 19 can also be safely ignored.

Part No: 502 Lot-for-Lot= 1562  
 Part Name: MEAL, READY TO EAT LT= 4 week(s)

Exercise Support Requirements:		Backlog	Week 1	2	3	4	5	6	7	8	9	10	11	12	Future
Part No.	Qty per	11-Nov	18-Nov	25-Nov	02-Dec	09-Dec	16-Dec	23-Dec	30-Dec	06-Jan	13-Jan	20-Jan	27-Jan	03-Feb	
per 301	22	0	0	0	0	0	0	0	0	0	0	0	0	0	ERR
per 303	22	0	0	0	0	0	0	0	0	0	0	0	0	0	ERR
per 308	22	0	0	0	0	0	0	0	0	0	0	0	0	0	ERR
per 320	22	0	0	0	0	0	0	0	0	0	0	0	0	0	ERR
per 326	22	0	0	0	0	0	0	0	0	0	0	0	0	0	ERR
per 417	22	0	0	0	0	0	0	0	0	0	0	0	0	0	ERR
per 421	22	0	0	0	0	0	0	0	0	0	0	0	0	0	ERR
per 422	22	0	0	0	0	0	0	0	0	0	0	0	0	0	ERR
Total Requirements		0	0	0	0	0	1562	0	0	0	0	0	0	0	ERR

Outstanding Orders:		11-Nov	18-Nov	25-Nov	02-Dec	09-Dec	16-Dec	23-Dec	30-Dec	06-Jan	13-Jan	20-Jan	27-Jan	03-Feb
Order Date	Qty													
08/31/96	500													
09/09/96	324													
Scheduled Receipts		0	0	0	0	0	0	0	0	0	0	0	0	0

On Hand Quantity:	240	240	240	240	240	-1322	0	0	0	0	0	0	0	0	ERR
Planned Order Releases:		1322	0	0	0	0	0	0	ERR	ERR	ERR	ERR	ERR	ERR	ERR

REMARKS: O/O QUANTITIES UNDEDICATED, CAN BE USED TO SUPPORT THIS EXERCISE  
 Class I Requirements to be submitted by 08/15/96

Figure 19. a). CAX 8-93 Part 502: Meals Ready to Eat Lower Level Template. (After Sounderpandian, 1989)

Part No: 503 Lot-for-Lot= 1917  
 Part Name: HOT MEALS LT= 4 week(s)

Qty per	Part No.	Backlog	Week 1	2	3	4	5	6	7	8	9	10	11	12	Future
			11-Nov	18-Nov	25-Nov	02-Dec	09-Dec	16-Dec	23-Dec	30-Dec	06-Jan	13-Jan	20-Jan	27-Jan	03-Feb
27	per 301	0	0	0	0	0	0	0	0	0	0	0	0	0	ERR
27	per 303	0	0	0	0	0	0	0	0	0	0	0	0	0	ERR
27	per 308	0	0	0	0	0	0	0	0	0	0	0	0	0	ERR
27	per 320	0	0	0	0	0	0	0	0	0	0	0	0	0	ERR
27	per 328	0	0	0	0	0	0	0	0	0	0	0	0	0	ERR
27	per 417	0	0	0	0	0	0	0	0	0	0	0	0	0	ERR
27	per 421	0	0	0	0	0	0	0	0	0	0	0	0	0	ERR
27	per 422	0	0	0	0	0	0	0	0	0	0	0	0	0	ERR
	Total Requirements	0	0	0	0	0	1917	0	0	0	0	0	0	0	ERR
	On Hand	0	0	0	0	0	-1917	-1917	-1917	-1917	-1917	-1917	-1917	-1917	ERR
	Planned Order Releases	1917	0	0	0	0	0	0	0	0	0	0	0	0	ERR

REMARKS: Class I Requirements to be submitted by 08/15/96

Figure 19. b). CAX 8-93 Part 503: Hot Meals Lower Level Template. (After Sounderpandian, 1989)

*b. Class II: Consumable Supplies Calculations*

This model calculates the requirements for Class II consumable supply items as soon as the dependent demand relationships and current inventory status information has been input to the BOM/ISR. This information is linked to the appropriate lower level template for calculation of the exercise requirement. For example, Figure 20 shows both the BOM/ISR entry and the lower level template for Part Number 410, Engineer Tape. The identified requirement for engineer tape is one roll per Part Number 316, Platoon Pioneer Kit, of which six are required for the exercise. The current on-hand quantity is two rolls, and the lead time for obtaining this item is one week. By linking this information to the lower level template with the planned order release information from the intermediate level template for Part Number 316, it is determined that the requirement for six rolls of engineer tape is due no later than 9 December. For the same reasons previously mentioned, the "ERR" warning messages in Figure 20 can also be safely ignored.

The company commander would then update the lower level part template with the specific data of undedicated on-order supplies and materials that could be used to satisfy this exercise requirement. From the example in Figure 19, the two rolls of engineer tape due in by 25 November can be used to partially satisfy this requirement. The model takes into consideration the two undedicated on-hand rolls in determining the total net requirement of two rolls to be placed on order. Adjusting for the lead time, the model informs the company commander that he must have those items ordered by 2 December to ensure their timely delivery. Finally, any specific notes, remarks or assumptions that were made for the particular part should be annotated in the remarks block.

a).

Bill of Materials/Inventory Status Record											
Component Part No / Part Name	Sub	Gross	Lead	On Hand							
Quantity/Percent Part No/ Part Name	Total	Reqmt.	Time	Quantity							
410 Engineer Tape 1 Pcr: 316 TIKI, Pcr	6	6	1	2							

b).

Part No: 410      Lot-for-LoI= 6  
Part Name: ENGINEER TAPE      LT= 1 week(s)

Exercise Support Requirements:

Qty Per	Part No	Backlog	Week 1	2	3	4	5	6	7	8	9	10	11	12	Future
	Pcr: 316		11-Nov	18-Nov	25-Nov	02-Dec	09-Dec	16-Dec	23-Dec	30-Dec	06-Jan	13-Jan	20-Jan	27-Jan	03-Feb
Total Requirements	2	0	0	0	0	0	0	0	0	0	0	0	0	0	ERR

Outstanding Orders:

Order Date	Qty	Due Date	11-Nov	18-Nov	25-Nov	02-Dec	09-Dec	16-Dec	23-Dec	30-Dec	06-Jan	13-Jan	20-Jan	27-Jan	03-Feb
08/01/66	0	10/22/66													ERR
09/09/66	2	11/25/66			2										ERR
Scheduled Receipts	2		0	0	2	0	0	0	0	0	0	0	0	0	ERR

On Hand Quantity:

Planned Order Releases:	2	2	2	4	4	2	0	0	0	0	0	0	0	0	ERR
	0	0	0	0	0	0	0	0	0	0	0	0	0	0	ERR

REMARKS:  
OIO QUANTITIES UNDEDICATED, CAN BE USED TO SUPPORT THIS EXERCISE  
Class II Requirements to be submitted by 08/01/66

Figure 20. CAX 8-93 Part 410: Engineer Tape a). Bill of Materials/Inventory Status Record Template. b). Lower Level Template. (After Sounderpadian, 1989)

*c. Class III: Petroleum, Oil, and Lubricants (POL) Calculations*

To determine the requirements for bulk POL supplies the commander will use the templates shown in Figure 21. For each training period the number of vehicles and the anticipated hours of usage per day are input into the model. The product of the four columns are calculated for each training period, and the total is summed at the bottom.

In this particular example, the commander uses three HMMWVs for the training and FEX periods and two HMMWVs for the advance and rear party periods. For the input usage rates, in hours per day, the model calculates this item's total diesel fuel requirement of 171.7 gallons for the 20 day exercise. This quantity and those of the other equipment items and vehicles are linked to the BOM/ISR template where the gross bulk petroleum requirement of 2695 gallons of diesel fuel is calculated. This is shown in Figure 21b. By testing any combination of input variables: the number of vehicles, the hours per day, and the number of days the commander can easily perform what-if analysis and readily see the changes calculated in the outcome.

Figure 22 shows the templates used to determine the packaged POL supplies. Into the BOM/ISR the commander inputs the estimated requirement per vehicle. This is based on the anticipated maintenance actions to be performed during the exercise. The net totals per equipment item or vehicle are then summed to produce the gross exercise requirement for packaged POL supplies. From the lower level template, a net total that takes into consideration any on hand and on order supplies is then linked back into the POL calculation template where quotients for the different NSN unit-of-issues are calculated. The company commander now selects the NSN that offers the most economical means of satisfying the total exercise requirement.



a).

Class III: Petroleum, Oils and Lubricants Calculations							
Bulk Fuel - Diesel							
TAMCN	Nomenclature	# Vehicles	Gal/Hr	Hrs/Day	No. Days	Gallons	Total
B2460	Tractor, Full-Trk, Angle Blade, Case 1150E						
	Advance Party	0	4	0	3	0	
	Training Period	0	4	0	12	0	
	FEX	0	4	0	3	0	
	Rear Party	0	4	0	2	0	
	<b>Total</b>						<b>0</b>
B2462	Tractor, Full-Trk, Medium, D7G						
	Advance Party	0	6	0	3	0	
	Training Period	1	6	1	12	72	
	FEX	1	6	2	3	36	
	Rear Party	0	6	0	2	0	
	<b>Total</b>						<b>108</b>
B2482	Tractor, All Whl Dr, w/ Attach., SEE						
	Advance Party	0	4	0	3	0	
	Training Period	1	4	1	12	48	
	FEX	2	4	4	3	96	
	Rear Party	0	4	0	2	0	
	<b>Total</b>						<b>144</b>
B2567	Tractor, Rubber Tire, Artic. Str, TRAM						
	Advance Party	1	4	4	3	48	
	Training Period	1	4	1	12	48	
	FEX	1	4	2	3	24	
	Rear Party	1	4	4	2	32	
	<b>Total</b>						<b>152</b>
D0209	Power Unit, Front, 12.5-ton, MK48						
	Advance Party	1	16.66	3	3	149.94	
	Training Period	1	16.66	1	12	199.92	
	FEX	1	16.66	4	3	199.92	
	Rear Party	1	16.66	5	2	166.6	
	<b>Total</b>						<b>716.38</b>
D1059	Truck, Cargo, 5-ton, M923						
	Advance Party	1	11.5	3	3	103.5	
	Training Period	2	11.5	2	12	552	
	FEX	2	11.5	5	3	345	
	Rear Party	1	11.5	2	2	46	
	<b>Total</b>						<b>1046.5</b>
D1072	Truck, Dump, 5-ton, M929						
	Advance Party	1	11.5	2	3	69	
	Training Period	1	11.5	1	12	138	
	FEX	1	11.5	3	3	103.5	
	Rear Party	1	11.5	2	2	46	
	<b>Total</b>						<b>356.5</b>
D1158	Truck, Utility, 1.25-ton, HMMWV						
	Advance Party	2	1.7	2	3	20.4	
	Training Period	3	1.7	1	12	61.2	
	FEX	3	1.7	5	3	76.5	
	Rear Party	2	1.7	2	2	13.6	
	<b>Total</b>						<b>171.7</b>

b).

Bill of Materials/ Inventory Status Record					
Component Part No./ Part Name	Sub Total	Gross Reqmt.	Lead Time	On Hand Quantity	
511 Diesel Fuel					
Total per 310 HMMWV	171.7				
Total per 321 TRAM	152				
Total per 322 SEE	144				
Total per 323 D7G	108				
Total per 325 1150E	0				
Total per 328 M923	1046.5				
Total per 330 M929	356.5				
Total per 418 Mk48	716.38				
		2695.08	0	0	

Figure 21. CAX 8-93 a). Petroleum, Oils and Lubricants Calculation Template, Bulk Fuel-Diesel. b). Part 511: Diesel Fuel Bill of Materials/Inventory Status Record

a).

Bill of Materials/ Inventory Status Record						
Component	Part No./ Part Name	Sub	Gross	Lead	On Hand	
	Quantity/ Parent Part No./ Part Name	Total	Reqmt.	Time	Quantity	
506	Anti-Freeze (Gal./Part No.)					
	5 per 310 HMMWV	15				
	0 per 321 TRAM	0				
	5 per 322 SEE	10				
	0 per 323 D7G	0				
	0 per 325 1150E	0				
	0 per 328 M923	0				
	5 per 330 M929	5				
	5 per 418 MK48	5				
			35	2		1

b).

Class III: Petroleum, Oils and Lubricants Calculations					
Packaged Petroleum Products					
NSN	Nomenclature	Unit Issue	Qty.	Req. Qty	
6810-00-249-9354	Electrolyte	Gl	3	3	
6850-00-181-7929	Anti-Freeze	1-Gl Bt	9	0	
6850-00-181-7933	Anti-Freeze	5-GL CN	1.8	2	
6850-00-181-7940	Anti-Freeze	55-Gl Dr	0.163636	0	
9150-00-189-6727	Lube Oil, 10wt	1-Qt Cn	8	8	
9150-00-186-6668	Lube Oil, 10wt	5-Gl Cn	0.4	0	
9150-00-191-2772	Lube Oil, 10wt	55-Gl Dr	0.036364	0	
9150-00-186-6681	Lube Oil, 30wt	1-Qt Cn	140	0	
9150-00-188-9858	Lube Oil, 30wt	5-Gl Cn	7	7	
9150-00-189-6729	Lube Oil, 30wt	55-Gl Dr	0.636364	0	
9150-00-035-5392	Lube Oil, 90wt	1-Qt Cn	164	0	
9150-00-035-5393	Lube Oil, 90wt	5-Gl Cn	8.2	0	
9150-00-035-5394	Lube Oil, 90wt	55 Gl Dr	0.745455	1	
9150-00-190-0905	Grease, GAA	6.5-Lb Cn	2.307692	3	
9150-00-190-0907	Grease, GAA	35-Lb Cn	0.428571	0	
9150-01-053-6688	CLP	Gl	0.789063	1	
9150-01-054-6453	CLP	Pt	6.3125	0	

Figure 22. CAX 8-93 a). Part 506: Antifreeze Bill of Material/ Inventory Status Record. b). Petroleum, Oils and Lubricants Calculation Template, Packaged Petroleum Products

For example, the BOM/ISR in Figure 22b. indicates that for Part Number 506, Antifreeze there is a requirement of five gallons for each HMMWV, SEE tractor, M929 5-ton truck, and M48 power unit, for a gross requirement of 35 gallons. Since there are 25 gallons on order already and one gallon on hand, the net requirement for this exercise is nine gallons. Antifreeze is offered in three distinct units-of-issue: one gallon bottle, five gallon can, and 55 gallon drum. To satisfy the total requirement it takes nine bottles, 1.8 cans or 0.16 drums of antifreeze. At this point the commander can select the particular NSN for the training exercise. In this case two five gallon cans of antifreeze will be requisitioned to support this training exercise, as shown in Figure 22b.

*d. Class VII: Major End Item Calculations*

Class VII major end item requirements are determined in the same manner as the Class II consumable supplies. Dependent demand relationships and current inventory status input to the BOM/ISR are linked to the appropriate intermediate level template for calculation of the exercise requirement. For example, Figure 23 shows both the BOM/ISR entry and the intermediate level template for Part Number 316, Engineer Squad Pioneer Tool Kit. The identified requirement is one kit per Part Number 202, Combat Engineer Squad, of which a total of six will be required to support the exercise. The current on-hand quantity for this item as well as many of the other major end items is artificially kept at zero. This is done to force the calculation of subcomponents and sub-subcomponents. The lead time for obtaining this item is zero weeks since this tool kit is part of the engineer company's authorized Table of Equipment. By linking this information with the planned order release information from Part Number 202, it is determined that a requirement for six pioneer tool kits needs to be available no later than 9 December. Again, the "ERR" warning

a).

Bill of Materials/ Inventory Status Record				
Component Part No./ Part Name	Sub Total	Gross Reqmt.	Lead Time	On Hand Quantity
316 Tool Kit, Pioneer, Engr Squad		6	0	0
1 per 202 Engr Squad				

b).

Part No: 316 Lot-for-Lot= 6 LT= 0 week(s)  
 Part Name: TOOL KIT, PIONEER, ENGR SQUAD

Exercise Support Requirements:

Qty per	Part No.	Per 202	1	2	3	4	5	6	7	8	9	10	11	12	Future
			11-Nov	18-Nov	25-Nov	02-Dec	09-Dec	16-Dec	23-Dec	30-Dec	06-Jan	13-Jan	20-Jan	27-Jan	03-Feb
Total Requirements	0	0	0	0	0	0	0	0	0	0	0	0	0	0	ERR
On Hand	0	0	0	0	0	0	0	0	0	0	0	0	0	0	ERR
Planned Order Releases	0	0	0	0	0	0	0	0	0	0	0	0	0	0	ERR

REMARKS:

Figure 23. CAX 8-93 Part 316: Tool Kit, Pioneer, Engineer Squad a). Bill of Materials/Inventory Status Record. b). Lower Level Template

messages in Figure 23 can be safely ignored. Appendix D contains all the intermediate and lower level templates used in the CAX 8-93 example.

*e. Report Generation*

Once the information has been input to the model, the inherent capabilities of the spreadsheet software takeover and automatically calculate the material requirements and produce the required reports that display this data. The reports used in illustrating this example can be found in Figures 24 through 27. Should any of the assumptions and input variables change, which is almost always the case in exercise planning, the new ones can easily be reapplied and the results instantaneously seen. What-if analysis can be done easily to see the impacts of changes in personnel strength and equipment density on the overall material requirements needed to support the exercise. The "ERR" warning messages found in some cells of Figure 27 can be safely ignored for the same reasons as mentioned previously.

<u>Table of Organization</u>			
Unit	MOS	Quantity	Quantity
<u>Cbt Engr Platoon</u>		2	
<u>Platoon Headquarters</u>		2	
	1302/1371SNCO		6
	1371		2
	2531		3
<u>Engineer Squad</u>		6	
	1371		48
<u>HE/MT Section</u>		1	
	1341		2
	1345		4
	3521		2
	3531		3
	3533		1
Total			<u>71</u>

**Figure 24. CAX 8-93 Table of Organization Report**

Equipment Density List		
TAMCN	Nomenclature	Quantity
A2050	Radio Set, PRC-77	6
B0215	Bucket, Scoop, TRAM	1
B0471	Demolition Equipment, Engineer Sqd	6
B0475	Detecting Set, Mine, Metallic, AF-108	6
B0647	Forklift Attachment, TRAM	1
B1298	Line Charge Launch Kit, Trailer-Mounted	2
B1320	Minefield Marking Set	1
B1830	Saw, Chain, One-Man Portable	0
B2210	Tool Kit, Carpenter's, Engineer Platoon	1
B2260	Tool Kit, Pioneer, Engineer Squad	6
B2460	Tractor, Full-Tracked, w/ Angled Blade, Case 1150E	0
B2462	Tractor, Full-Tracked, Medium, D7G	1
B2482	Tractor, All Wheel Drive, w/ Attachments, SEE	2
B2567	Tractor, Rubber Tired, Articulated Steering, TRAM	1
C4436	Can, Water	10
C6490	Tool Kit, General Mechanics	2
D0209	Power Unit, Front, 12.5-ton, MK48	1
D0235	Trailer, Semi-, Lowbed, 40-ton, M870	1
D0860	Trailer, Cargo, 1.5-ton, 2-Wheel, M105	1
D0878	Trailer, Semi-, Powered, 5th Wheel, MK16	1
D1059	Truck, Cargo, 5-ton, M923	1
D1072	Truck, Dump, 5-ton, M929	1
D1158	Truck, Utility, 1.25-ton, HMMWV	3
E0915	Launcher, Assault Rocket, 83mm, SMAW	0
E0960	Machine Gun, Light, Squad, Automatic, SAW, M-249	6
E0993	Machine Gun, 7.62mm, M60E3	0
E1120	Mount, Tripod, Machine Gun, 7.62mm, M-122	0
E1151	Night Vision Goggles, Individual, AN/PVS-5A	4
E1158	Night Vision Sight, Individual Served Weapon, AN/PVS-4	2
E1250	Pistol, 9mm, Semiautomatic, M-9	6
E1441	Rifle, 5.56mm, M16A2	59
K4222	Compass	9
N6001	Binoculars	5

Figure 25. CAX 8-93 Equipment Density List Report

Consumable Materials			
NSN	Nomenclature	Unit Issue	Quantity
1005-00-288-3565	Patches,7.62	Pg	12
1005-00-912-4248	Patches, 5.56	Pg	65
5790-00-816-6056	Tape, Electrical	Ro	12
6135-00-930-0030	Battery, BA-3030	Pg	3
6135-01-034-2239	Battery, BA-5598	Ea	24
6135-01-090-5365	Battery, BA-5567/U	Ea	18
6260-01-074-4229	Cyalume, LtStk, Yellow	Bx	4
6260-01-178-5559	Cyalume, LtStk, Red	Bx	4
6260-01-178-5560	Cyalume, LtStk, Blue	Bx	4
6810-00-249-9354	Electrolyte	Gl	3
6850-00-161-6204	Camouflage Stick	Ea	6
6850-00-181-7929	Anti-Freeze	1-Gl Bt	0
6850-00-181-7933	Anti-Freeze	5-Gl Cn	2
6850-00-181-7940	Anti-Freeze	55-Gl Dr	0
7340-00-022-1315	Fork, Plastic	Hd	20
7340-00-022-1317	Spoon, Plastic	Hd	20
7340-00-022-1316	Knife, Plastic	Hd	20
7350-00-290-0593	Plate, Paper	Bx	2
7350-00-456-2024	Cup, Paper	Bx	1
8540-00-276-7569	Napkin, Paper	Bx	1
8315-00-255-7662	Engineer Tape	Ro	6
9140-00-273-2377	Diesel Fuel	Gl	2695.08
9150-00-189-6727	Lube Oil, 10wt	1-Qt Cn	8
9150-00-186-6668	Lube Oil, 10wt	Cn	0
9150-00-191-2772	Lube Oil, 10wt	55-Gl Dr	0
9150-00-186-6681	Lube Oil, 30wt	1-Qt Cn	0
9150-00-188-9858	Lube Oil, 30wt	5-Gl Cn	7
9150-00-189-6729	Lube Oil, 30wt	Dr	0
9150-01-035-5392	Lube Oil, 90wt	1-Qt Cn	0
9150-01-035-5395	Lube Oil, 90wt	5-Gl Cn	0
9150-00-035-5393	Lube Oil, 90wt	55 Gl Dr	1
9150-00-190-0905	Grease, GAA	6.5-Lb Cn	3
9150-00-190-0907	Grease, GAA	Cn	0
9150-00-053-6688	CLP	Gl	1
9150-00-054-6453	CLP	Pt	0

Figure 26. CAX 8-93 Bill of Consumable Materials Report

Material Orders Releases Report														
Part No.	Backlog	11-Nov	18-Nov	25-Nov	02-Dec	09-Dec	16-Dec	23-Dec	30-Dec	06-Jan	13-Jan	20-Jan	27-Jan	03-Feb
101	0	0	0	0	0	0	2	0	0	0	0	0	0	ERR
201	0	0	0	0	0	0	2	0	0	0	0	0	0	ERR
202	0	0	0	0	0	0	6	0	0	0	0	0	0	ERR
203	0	0	0	0	0	0	1	0	0	0	0	0	0	ERR
301	0	0	0	0	6	0	0	0	0	0	0	ERR	ERR	ERR
302	0	0	0	0	0	2	0	0	0	0	0	0	0	ERR
303	0	0	0	0	50	0	0	0	0	0	0	ERR	ERR	ERR
304	0	0	0	0	0	2	0	0	0	0	0	0	0	ERR
305	0	0	0	0	0	4	0	0	0	0	0	0	0	ERR
306	0	0	0	0	3	0	0	0	0	0	0	ERR	ERR	ERR
307	0	0	0	0	6	0	0	0	0	0	0	ERR	ERR	ERR
308	0	0	0	0	0	0	0	0	0	0	0	0	0	ERR
309	0	0	0	0	0	3	0	0	0	0	0	0	0	ERR
310	0	0	0	0	0	3	0	0	0	0	0	0	0	ERR
311	0	0	0	0	0	0	0	0	0	0	0	0	0	ERR
312	0	0	0	0	0	0	1	0	0	0	0	0	0	ERR
313	0	0	0	0	0	6	0	0	0	0	0	0	0	ERR
314	0	0	0	0	0	0	0	0	0	0	0	0	0	ERR
315	0	0	0	0	0	0	6	0	0	0	0	0	0	ERR
316	0	0	0	0	0	0	6	0	0	0	0	0	0	ERR
317	0	0	0	0	0	0	0	0	0	0	0	0	0	ERR
318	0	0	0	0	0	0	6	0	0	0	0	0	0	ERR
319	0	0	0	0	3	0	0	0	0	0	ERR	ERR	ERR	ERR
320	0	0	0	0	0	2	0	0	0	0	0	ERR	ERR	ERR
321	0	0	0	0	0	1	0	0	0	0	0	ERR	ERR	ERR
322	0	0	0	0	0	2	0	0	0	0	0	ERR	ERR	ERR
323	0	0	0	0	0	1	0	0	0	0	0	ERR	ERR	ERR
324	0	0	0	0	0	2	0	0	0	0	0	ERR	ERR	ERR
325	0	0	0	0	0	0	0	0	0	0	0	ERR	ERR	ERR
326	0	0	0	0	0	2	0	0	0	0	0	ERR	ERR	ERR
327	0	0	0	0	0	1	0	0	0	0	0	ERR	ERR	ERR
328	0	0	0	0	0	2	0	0	0	0	0	ERR	ERR	ERR
329	0	0	0	0	0	1	0	0	0	0	0	ERR	ERR	ERR
330	0	0	0	0	0	1	0	0	0	0	0	ERR	ERR	ERR
401	0	0	0	0	0	6	0	0	0	0	0	ERR	ERR	ERR
402	0	0	0	0	0	0	4	0	0	0	0	ERR	ERR	ERR
403	0	0	12	0	0	0	0	0	0	ERR	ERR	ERR	ERR	ERR
404	0	14	0	0	0	0	0	0	ERR	ERR	ERR	ERR	ERR	ERR
405	0	0	0	0	0	0	0	0	0	0	0	ERR	ERR	ERR
406	0	0	0	0	0	3	0	0	0	0	0	ERR	ERR	ERR
407	0	0	0	0	0	2	0	0	0	0	0	ERR	ERR	ERR
408	0	0	0	0	0	1	0	0	0	0	0	ERR	ERR	ERR
409	0	0	0	0	0	36	0	0	0	0	0	ERR	ERR	ERR
410	0	0	0	0	0	2	0	0	0	0	0	ERR	ERR	ERR
411	0	0	0	0	0	0	0	0	0	0	0	ERR	ERR	ERR
412	0	0	0	0	0	5	0	0	0	0	0	ERR	ERR	ERR
413	0	75	0	0	0	0	0	0	ERR	ERR	ERR	ERR	ERR	ERR
414	0	0	0	0	0	2	0	0	0	0	0	ERR	ERR	ERR
415	0	0	0	0	0	1	0	0	0	0	0	ERR	ERR	ERR
416	0	0	0	0	0	1	0	0	0	0	0	ERR	ERR	ERR
417	0	0	0	0	0	4	0	0	0	0	0	ERR	ERR	ERR
418	0	0	0	0	0	1	0	0	0	0	0	ERR	ERR	ERR
419	0	0	0	0	0	1	0	0	0	0	0	ERR	ERR	ERR
420	0	0	0	0	0	1	0	0	0	0	0	ERR	ERR	ERR
421	0	0	0	0	0	1	0	0	0	0	0	ERR	ERR	ERR
422	0	0	0	0	0	3	0	0	0	0	0	ERR	ERR	ERR
501	0	5	0	0	0	0	0	0	ERR	ERR	ERR	ERR	ERR	ERR
502	1322	0	0	0	0	0	0	ERR	ERR	ERR	ERR	ERR	ERR	ERR
503	1917	0	0	0	0	0	0	ERR	ERR	ERR	ERR	ERR	ERR	ERR
504	0	0	0	0	0	59	0	0	0	0	0	ERR	ERR	ERR
505	0	0	0	0	3	0	0	0	0	ERR	ERR	ERR	ERR	ERR
506	0	0	0	9	0	0	0	0	0	ERR	ERR	ERR	ERR	ERR
507	0	0	2	0	0	0	0	0	0	ERR	ERR	ERR	ERR	ERR
508	0	0	20	15	0	0	0	0	0	ERR	ERR	ERR	ERR	ERR
509	0	0	43	0	0	0	0	0	0	ERR	ERR	ERR	ERR	ERR
510	0	0	9	6	0	0	0	0	0	ERR	ERR	ERR	ERR	ERR
511	0	0	0	0	2695.08	0	0	0	0	0	0	ERR	ERR	ERR
512	0	0	0	0	0	0	0	0	0	0	0	ERR	ERR	ERR
601	0	0	0	83	18	0	0	0	0	0	ERR	ERR	ERR	ERR
602	0	0	0	0	0	ERR	ERR	ERR	ERR	ERR	ERR	ERR	ERR	ERR
603	0	0	0	0	0	ERR	ERR	ERR	ERR	ERR	ERR	ERR	ERR	ERR
604	0	0	0	0	0	ERR	ERR	ERR	ERR	ERR	ERR	ERR	ERR	ERR
605	0	0	0	0	0	0	0	0	ERR	ERR	ERR	ERR	ERR	ERR

Figure 27. CAX 8-93 Planned Orders Release Report



### **3. MRP II and Material Costs**

Just as private industry has expanded MRP to Manufacturing Resources Planning (MRP II), so too can MRP on spreadsheets be taken a step further in the same direction. By augmenting the material requirements with material cost data, the costing of supplies and materials required for training exercises can be automated. The Consumable Materials Cost Estimate Report is similar to the Bill of Consumable Materials, with the exception of two additional columns as shown in Figure 28. The Unit Price column allows the user to input cost information for each consumable item. The Total Price column calculates the quantity of each item multiplied by its unit price. The total requirement of \$4251.27 to support the required consumable materials is summed at the bottom of the report. By doing so, the costs of conducting a training exercise can be determined with greater accuracy, instantly reflecting the changes in fiscal requirements as changes in material requirements occur.

### **4. Stochastic Influence on Lead Time Variability**

Through simulation, the add-in program Crystal Ball allows the logistics planner to incorporate probability into the analysis of lead time variability on the model. Assumption cells are used to identify the stochastic independent variables that affect the model. The user describes the uncertainty of lead time by defining assumptions for its probability distribution and expected data values. Forecast cells contain the dependent variable formulas that are linked back to the assumption cells. By selecting the number of iterations to run, the type of analysis, and the graphical outputs, the user can judge the influence and effect of each assumption on the forecasted variable. (Sangster, 1994) Crystal Ball displays the results as a range of possible outcomes along with the likelihood of their occurrence. (Decisioneering, 1993)

Consumable Materials Cost Estimate					
NSN	Nomenclature	Unit Issue	Unit Price	Quantity	Total Price
1005-00-288-3565	Patches, 7.62	Pg	\$9.89	12	\$118.68
1005-00-912-4248	Patches, 5.56	Pg	\$3.97	65	\$258.05
5790-00-816-6056	Tape, Electrical	Ro	\$1.23	12	\$14.76
6135-00-930-0030	Battery, BA-3030	Pg	\$12.25	3	\$36.75
6135-01-034-2239	Battery, BA-5598	Ea	\$40.04	24	\$960.96
6135-01-090-5365	Battery, BA-5567/U	Ea	\$5.21	18	\$93.78
6260-01-074-4229	Cyalume, LtStk, Yellow	Bx	\$6.48	4	\$25.92
6260-01-178-5559	Cyalume, LtStk, Red	Bx	\$6.20	4	\$24.80
6260-01-178-5560	Cyalume, LtStk, Blue	Bx	\$6.48	4	\$25.92
6810-00-249-9354	Electrolyte	Gl	\$2.90	3	\$8.70
6850-00-161-6204	Camouflage Stick	Ea	\$0.59	6	\$3.54
6850-00-181-7929	Anti-Freeze	1-Gl Bt	\$5.30	0	\$0.00
6850-00-181-7933	Anti-Freeze	5-Gl Cn	\$20.23	2	\$40.46
6850-00-181-7940	Anti-Freeze	55-Gl Dr	\$220.12	0	\$0.00
7340-00-022-1315	Fork, Plastic	Hd	\$2.90	20	\$58.00
7340-00-022-1317	Spoon, Plastic	Hd	\$2.63	20	\$52.60
7340-00-022-1316	Knife, Plastic	Hd	\$3.16	20	\$63.20
7350-00-290-0593	Plate, Paper	Bx	\$25.88	2	\$51.76
7350-00-456-2024	Cup, Paper	Bx	\$84.76	1	\$84.76
8540-00-276-7569	Napkin, Paper	Bx	\$34.06	1	\$34.06
8315-00-255-7662	Engineer Tape	Ro	\$9.50	6	\$57.00
9140-00-273-2377	Diesel Fuel	Gl	\$0.70	2695.08	\$1,886.56
9150-00-189-6727	Lube Oil, 10wt	1-Qt Cn	\$1.27	8	\$10.16
9150-00-186-6668	Lube Oil, 10wt	5-Gl Cn	\$22.81	0	\$0.00
9150-00-191-2772	Lube Oil, 10wt	55-Gl Dr	\$195.40	0	\$0.00
9150-00-186-6681	Lube Oil, 30wt	1-Qt Cn	\$1.99	0	\$0.00
9150-00-188-9858	Lube Oil, 30wt	5-Gl Cn	\$19.11	7	\$133.77
9150-00-189-6729	Lube Oil, 30wt	Dr	\$172.75	0	\$0.00
9150-01-035-5392	Lube Oil, 90wt	1-Qt Cn	\$2.11	0	\$0.00
9150-01-035-5395	Lube Oil, 90wt	5-Gl Cn	\$25.01	0	\$0.00
9150-00-035-5393	Lube Oil, 90wt	55 Gl Dr	\$171.97	1	\$171.97
9150-00-190-0905	Grease, GAA	6.5-Lb Cn	\$5.40	3	\$16.20
9150-00-190-0907	Grease, GAA	35-LbCn	\$20.15	0	\$0.00
9150-00-053-6688	CLP	Gl	\$18.91	1	\$18.91
9150-00-054-6453	CLP	Pt	\$3.53	0	\$0.00
				Total	\$4,251.27

Figure 28. CAX 8-93 Consumable Materials Cost Estimate Report

Crystal Ball provides sixteen probability distributions to choose from in describing the uncertain variables within the model being solved. The normal distribution was selected for use in this analysis for its ability to describe many natural happening events. Three conditions for the Normal distribution include:

- Some value of the unknown variable, the mean of the distribution is the most likely to occur.
- The unknown variable is symmetrical about the mean, that is it as likely be above the mean as it is below the mean.
- The unknown variable is more likely to be closer to the mean than farther away.

The parameters for the Normal distribution include the mean and standard deviation. The lead times identified within the model are used as the mean or most likely occurrence. For the standard deviation or the average distance of a set of a values from the mean, the Crystal Ball default value of the mean divided by ten is used. The unavailability of the actual standard deviation precluded its use. Should the actual standard deviation later be determined it can easily be input into the simulation.

For this particular simulation Part number 413, Det Cord Connectors was used. Figure 29 displays the BOM/ISR and lower level template for this part. The lead time cell within the BOM/ISR was selected as the Assumption cell. The Normal distribution was selected and Crystal Ball automatically input the lead time of four as the mean and calculated .40 for the standard deviation. For the Forecast cell, the lead time cell in lower level template was used. After setting the preferences for the number of trials at 500, this simulation was run and the reports located in Appendix D were generated. As previously mentioned, the "ERR" warning messages found in Figure 29 can be safely disregarded.

Bill of Materials/Inventory Status Record			
Component Part No./Part Name	Sub Total	Gross Reqt.	Lead Time
413 Detonating Cord Connectors		150	
25 per 318 Demo Eq			75

Part No: 413 Lot-for-Lot= 150  
 Part Name: DETONATING CORD CONNECTORS LT= 4 week(s)

Exercise Support Requirements:

Qty per 25	Part No	Backlog	Week 1	2	3	4	5	6	7	8	9	10	11	12	Future
			11-Nov	18-Nov	25-Nov	02-Dec	09-Dec	16-Dec	23-Dec	30-Dec	06-Jan	13-Jan	20-Jan	27-Jan	03-Feb
25	per 318	0	0	0	0	0	0	0	0	0	0	0	0	0	0
Total Requirements		0	0	0	0	0	150	0	0	0	0	0	0	0	ERR

Outstanding Orders:

Order Date	Qty	Due Date	11-Nov	18-Nov	25-Nov	02-Dec	09-Dec	16-Dec	23-Dec	30-Dec	06-Jan	13-Jan	20-Jan	27-Jan	03-Feb
09/31/75	5	10/27/75													
09/09/75	20	11/09/75													
Scheduled Receipts			0	0	0	0	0	0	0	0	0	0	0	0	0

On Hand Quantity:	75	75	75	75	75	75	75	75	75	75	75	75	75	75	75
Planned Order Releases:	0	0	0	0	0	0	0	0	0	0	0	0	0	0	0

REMARKS: 0% QUANTITIES UNDEDICATED CAN BE USED TO SUPPORT THIS EXERCISE  
 Class II Requirements to be submitted by 08/01/76

Figure 29. CAX 8-93 Part 413: DET Cord Connectors a). Bill of Materials/Inventory Status Record Template. b). Lower Level Template. (After Sounderpandian, 1989)

The reports generated by Crystal Ball provide a summary of the simulation as well as a full set of descriptive statistics. A forecast chart also presents the displayed range of results for the given simulation. This displayed range includes all the generated values within 2.6 standard deviations of the mean. This includes almost 99 percent of the forecast values. In this particular case the lead times for Part 413 ranged from 2.82 to 5.11 weeks. A percentile breakdown of this information is also provided in the report, as is a display of the assumption against which this simulation was run.

What becomes readily apparent from the simulation report is that a mean lead time input into the model will not guarantee the timely receipt of supplies and materials prior to the required delivery date. Crystal Ball however, allows the user to determine the certainty level for a specific value of ranges. For example, the second report in Appendix D displays a certainty level of 50.4 percent for achieving a lead time of four weeks or less. By using a lead time of four weeks, supplies and materials will not arrive as required in half of the occurrences. By adjusting the upper limit of the range to a value of five weeks however, Crystal Ball easily determines the certainty of achieving this range at 99.6 percent which almost guarantees the availability of the required materials. This process can be extended to the other parts as well to determine the affects of lead time uncertainty on the model.

### **C. ANALYSIS**

The model developed in this research shows that it is possible to combine established business practices, like MRP, with current spreadsheet capabilities to produce a tool for the logistics manager. This decision support model provides the combat engineer company commander with an efficient alternative to the traditional method of manually calculating exercise material requirements.

## 1. Strengths

By using this model, what used to take several days of planning and calculating can now be done in several hours. Not only does the model provide quick calculations with increased accuracy, but it also allows the decision maker to immediately see the impacts of the planning and decisions that are being made. What-if analysis is as simple as typing a new variable into the appropriate cell. With the add-in program Crystal Ball and a basic understanding of statistics, the user can conduct planning that takes into consideration the uncertain stochastic environment he or she operates in every day. Also, by adding cost data to the model, cost estimates can now be simultaneously generated as the model is being used. Flexibility of this type is perhaps the most significant advantage that spreadsheet decision support models have to offer.

The spreadsheet's software allows the user to add, modify and delete features within the model. New parts can easily be added, as can new reports to display additional information requirements. In fact, each new exercise the model is applied to can serve as another iteration in the model's continual development and improvement, allowing it to more accurately reflect the material requirements being planned. Several models, each developed for a specific type of exercise, can be saved and quickly updated as future exercise requirements become available.

Another advantage of the MRP spreadsheet model is that it is cheap to use and easy to implement. All Marine Corps units possess the Lotus 1-2-3 software on which it was developed. For several years now, Marines have received training on the use of this particular software. In a relatively short period of time this model can be installed and running. With continued familiarization that comes with its use, those same Marines should be able to perform troubleshooting with the model as well. As technology continues to develop new and more capable items of hardware and

software, logistic solutions such as the model presented in this research should only be more user friendly and easy to develop and incorporate. (Sounderpandian, 1989)

## **2. Weaknesses**

While ease of learning spreadsheet software is considered one advantage, a disadvantage is that the user must have an understanding and knowledge of the theory and principles on which the model is based. From the author's own experience, knowledge of MRP and how it has been applied in the decision support model will be difficult to find in the Fleet Marine Force. This will have to be learned by the user, if the model is to be improved and further developed to meet the changing environment in which the Marine Corps operates.

Another shortcoming of the model is that the preparing and outfitting of combat engineer platoons to support training exercises does not always lend itself to be a perfect fit with the principles of MRP. The perfect dependent demand relationships do not exist for all items that make up the engineer platoon. For example, not all engineer squads will be able to have the exact same number of combat engineers.

In those instances, this model can get the user close to an approximate figure, however manual methods of calculating the requirement can have to be used to identify the actual requirement.

Likewise, if the company commander is providing more than one engineer platoon to support a training exercise, there is a strong likelihood that both engineer platoons will not be configured exactly alike, as an MRP environment would suggest. Since the model was built around the engineer platoon as the final product, the model has to be manipulated if the engineer company is to be participating in the exercise.

## V. SUMMARY, CONCLUSIONS AND RECOMMENDATIONS

### A. SUMMARY AND CONCLUSIONS

The purpose of this study was to explore the possibility of applying computer spreadsheets and common commercial practices, namely Materials Requirements Planning, to create a support tool for Marine Corps logistics decision makers. This involved a general discussion of the spreadsheets capabilities and MRP techniques available today. Also presented were the methods that Marine combat engineers currently use to compute material requirements, and a MRP spreadsheet model as a means of automating and simplifying the current process. To illustrate the spreadsheet model a case study was examined, to which the MRP spreadsheet model was applied.

Spreadsheet modeling is no longer limited to those who have access to specific computer software applications. Enhancements to available spreadsheet programs such as Lotus 1-2-3 can assist any manager to quantitatively model and analyze all but the most complex problems. Add-in programs have allowed managers to effectively narrow the gap on modeling those more complex scenarios. This thesis shows that spreadsheets can provide a good foundation for logistics decision support systems. The availability of powerful personal computers and spreadsheet programs make them a logical choice for logistics applications.

The spreadsheet decision support model developed in this study offers a tool to the logistics manager to plan for and calculate the requirements of Class I, II, III, and VII supplies and materials needed to support military training exercises. Crystal Ball was also shown to be useful in simulating one aspect of the uncertain environment in which military logisticians must operate. While not entirely perfect, this model surpasses the traditional method of manually calculating and performing



exercise requirements planning. The logistics decision maker can now more effectively conduct inventory planning of scarce resources, improve the utilization of existing stocks of materials, react faster to changes in exercise requirements, and provide increased customer service and satisfaction to the supported infantry units by ensuring the proper supplies and materials are available when they are supposed to be.

## **B. RECOMMENDATIONS**

The spreadsheet decision support model presented in this research has other applications within the Combat Engineer Battalion and the Fleet Marine Force that can be explored. Combat Engineers perform a wide variety of construction projects, of which the majority of the construction material estimation process is still done with manual methods. The need exists for a model that automates these methods and aids in the logistical planning of construction material requirements. The calculation and planning of demolition requirements is another area worthy of consideration for study. Finally, combat engineer battalions are not the only units that are task-organized to support the infantry in training exercises. Other combat support units, such as tank, artillery, and assault amphibious vehicle units could possibly benefit with modification of this model to support their specific material requirements planning.

## **APPENDIX A. ENGINEER PLATOON PRODUCT STRUCTURE**

The product structure for a reinforced combat engineer platoon as a final product exploded to show the dependent demand relationships that exist between the different levels of subassemblies and component parts is displayed here.

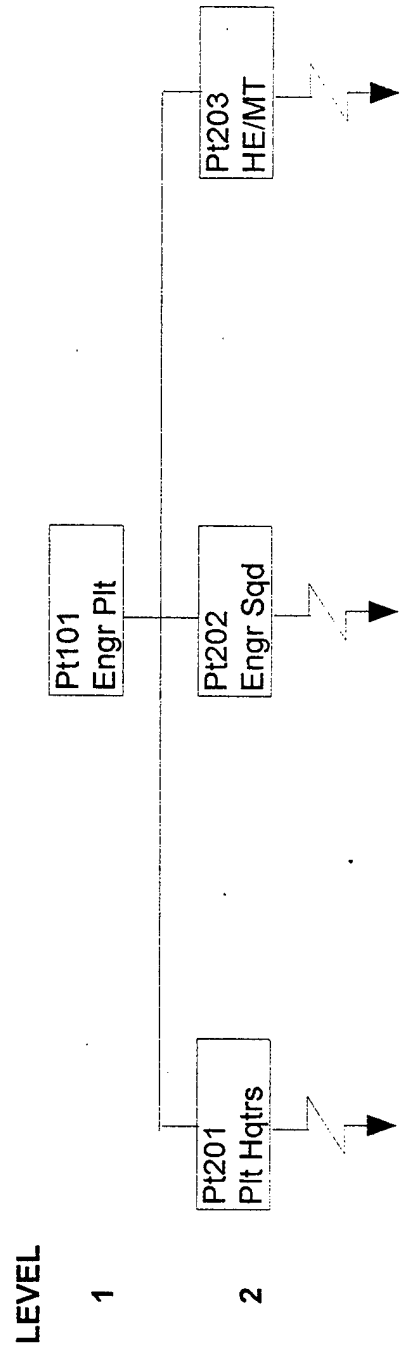

First level final product and second level subassemblies.

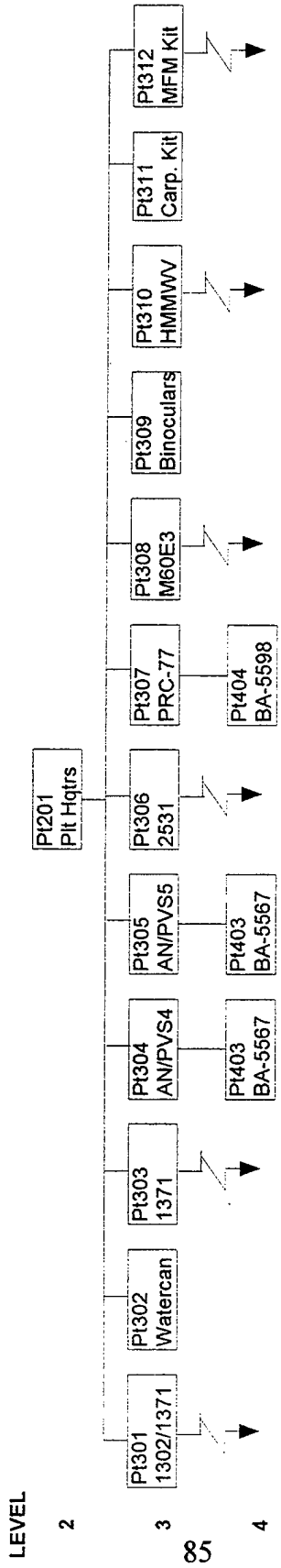

Second through fourth level subassemblies and component parts for Part 201, Platoon Headquarters.

LEVEL

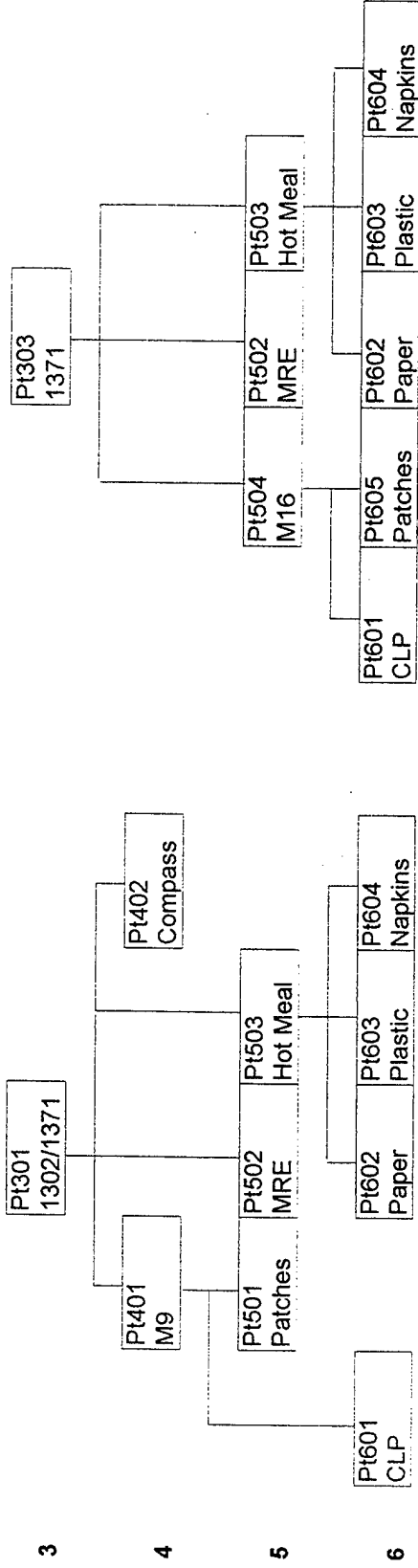

Third through sixth level subassemblies and component parts for Part 201, Platoon Headquarters.

LEVEL

3

Pt306  
2531

4

Pt504  
M16

Pt502  
MRE

Pt503  
Hot Meal

5

Pt601  
CLP

Pt605  
Patches

Pt602  
Paper

Pt603  
Plastic

Pt604  
Napkins

6

Pt308  
M60E3

Pt405  
Tripod

Pt501  
Patches

Pt601  
CLP

Third through sixth level subassemblies and component parts for Part 201, Platoon Headquarters.

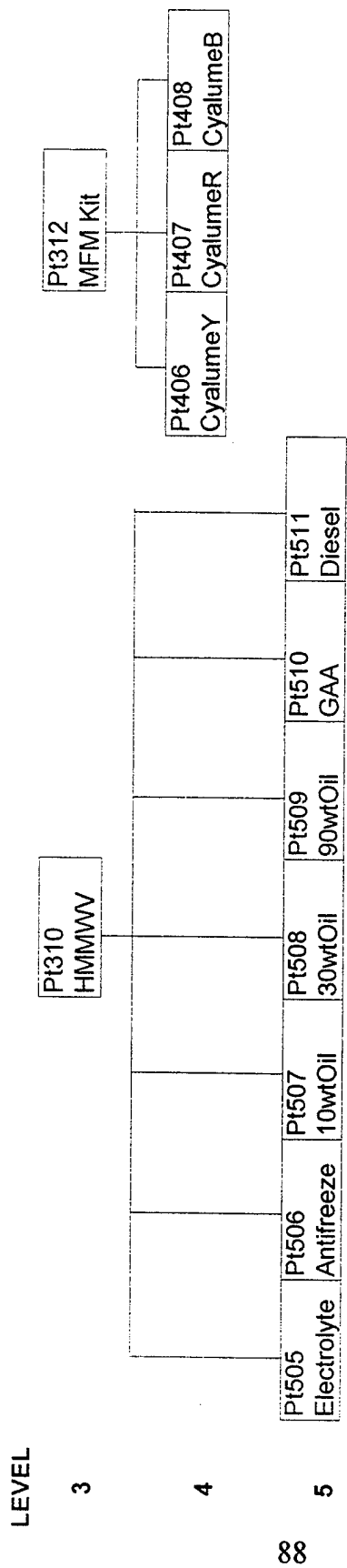

Third through sixth level subassemblies and component parts for Part 201, Platoon Headquarters.

LEVEL

2

PI202  
Engr Sqd

3

PI303  
1371

PI313  
AF-108

PI314  
SMAW

PI315  
SAW

PI307  
PRC-77

PI316  
P Ion. Kit

PI317  
Chain Saw

PI318  
Demo Kit

PI310  
HMMWV

PI319  
Camo SIK

4

PI409  
BA-3030

PI402  
Compass

PI404  
BA-5598

PI410  
Engr Tape

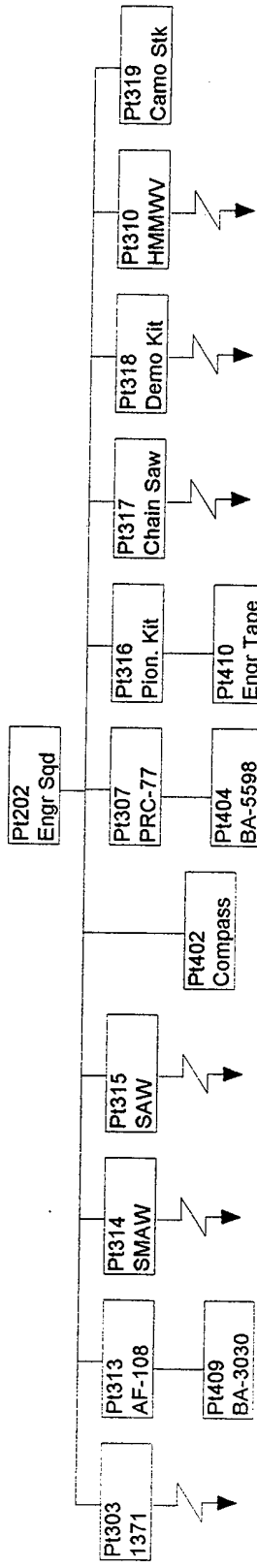

Second through fourth level subassemblies and component parts for Part 202, Engineer Squad.



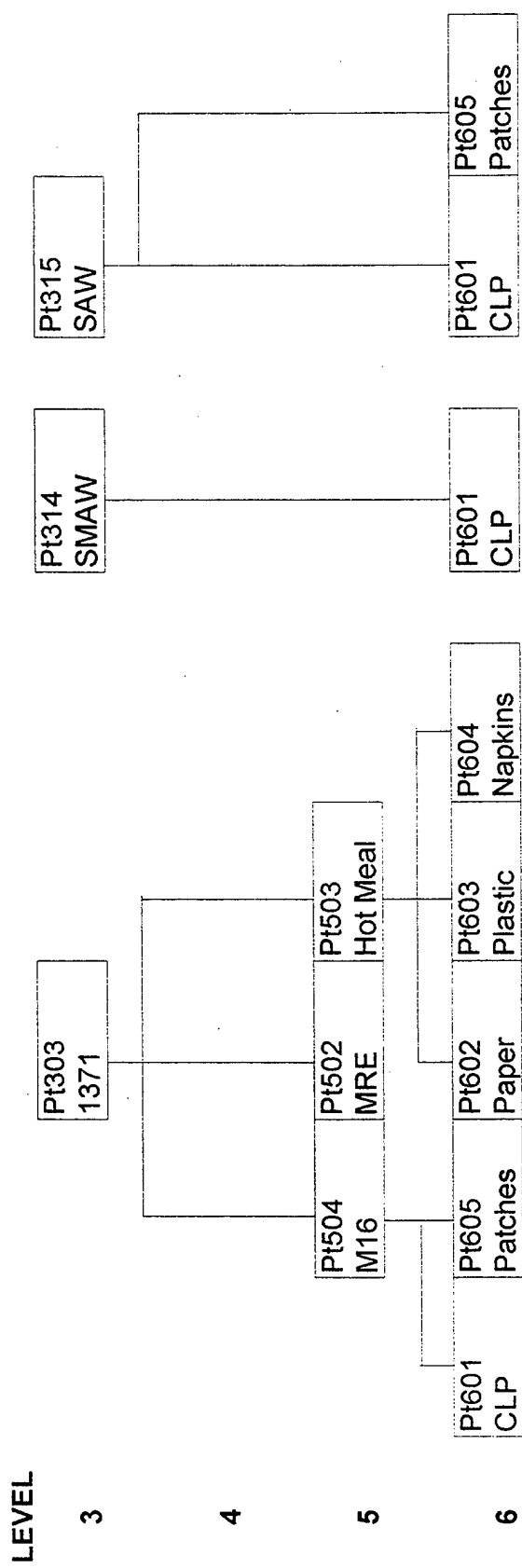

Third through sixth level subassemblies and component parts for Part 202, Engineer Squad.

LEVEL

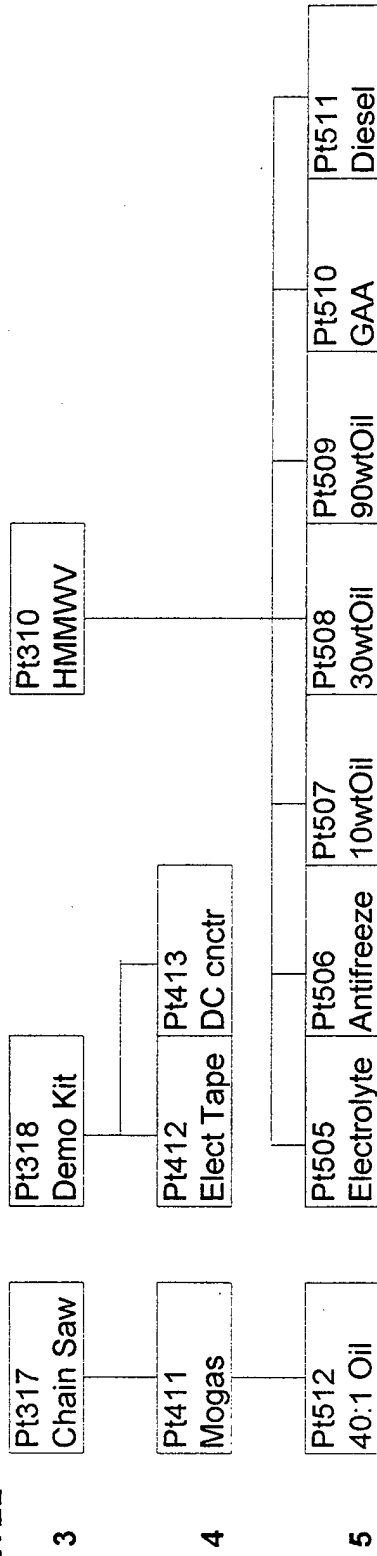

Third through sixth level subassemblies and component parts for Part 202, Engineer Squad.

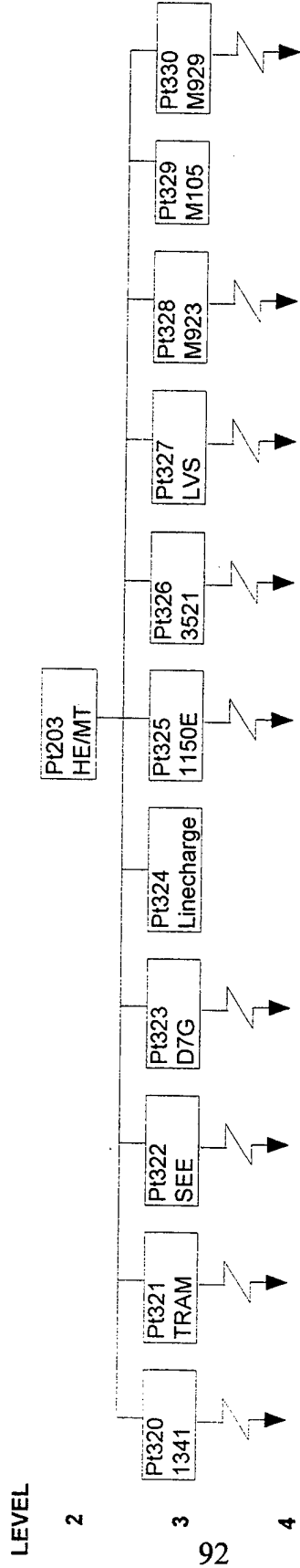

Second through fourth level subassemblies and component parts for Part 203, HE/MT Section.

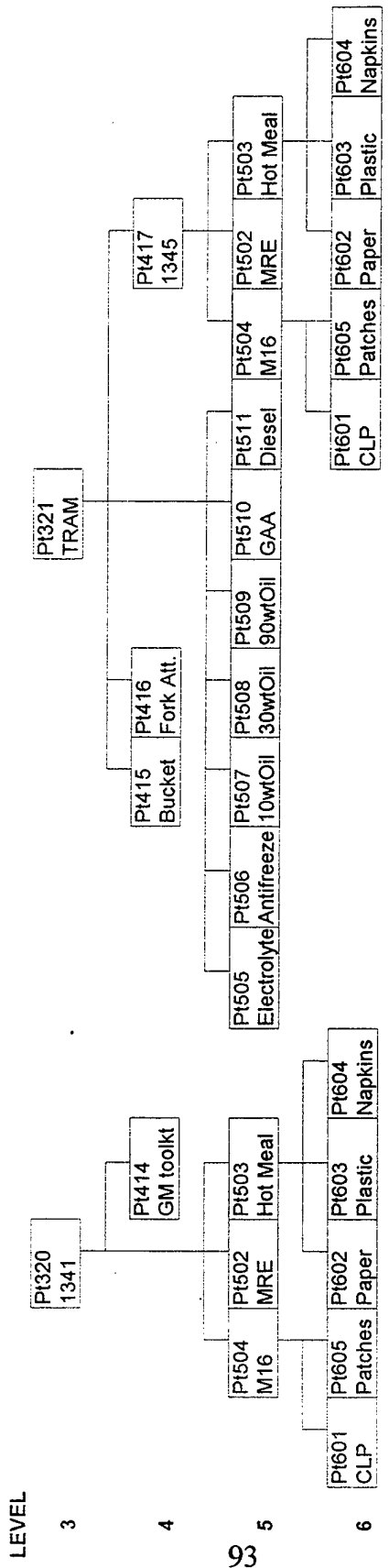

Third through sixth level subassemblies and component parts for Part 203, HE/MT Section.

LEVEL

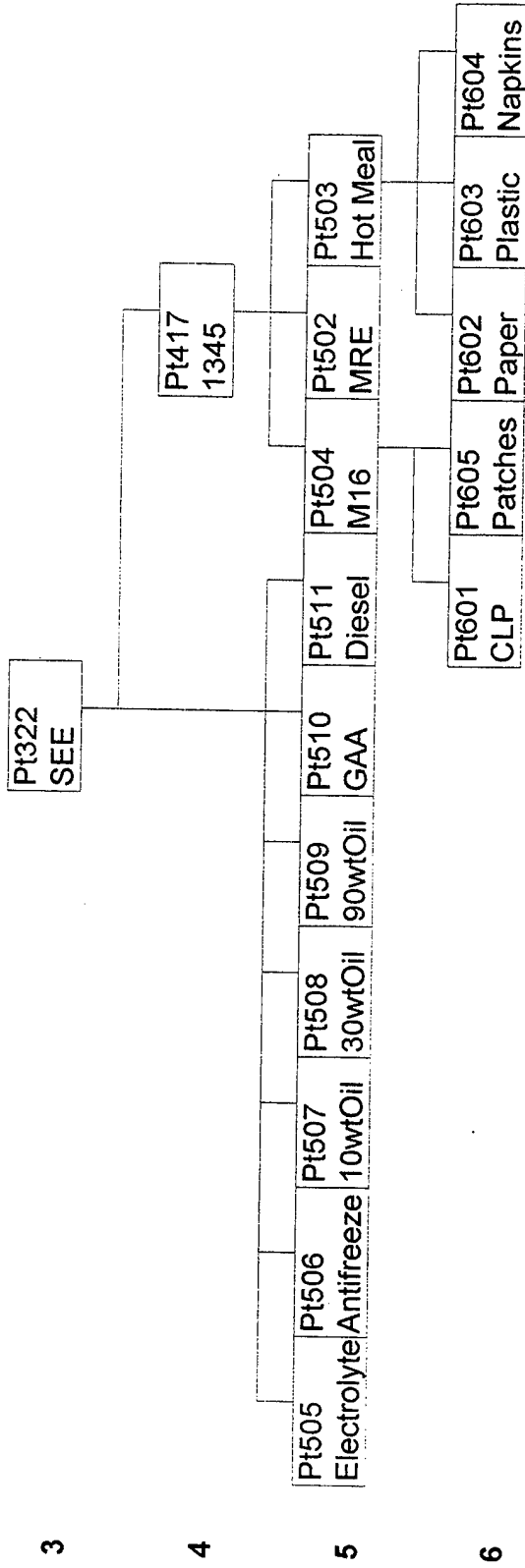

Third through sixth level subassemblies and component parts for Part 203, HE/MT Section.

LEVEL

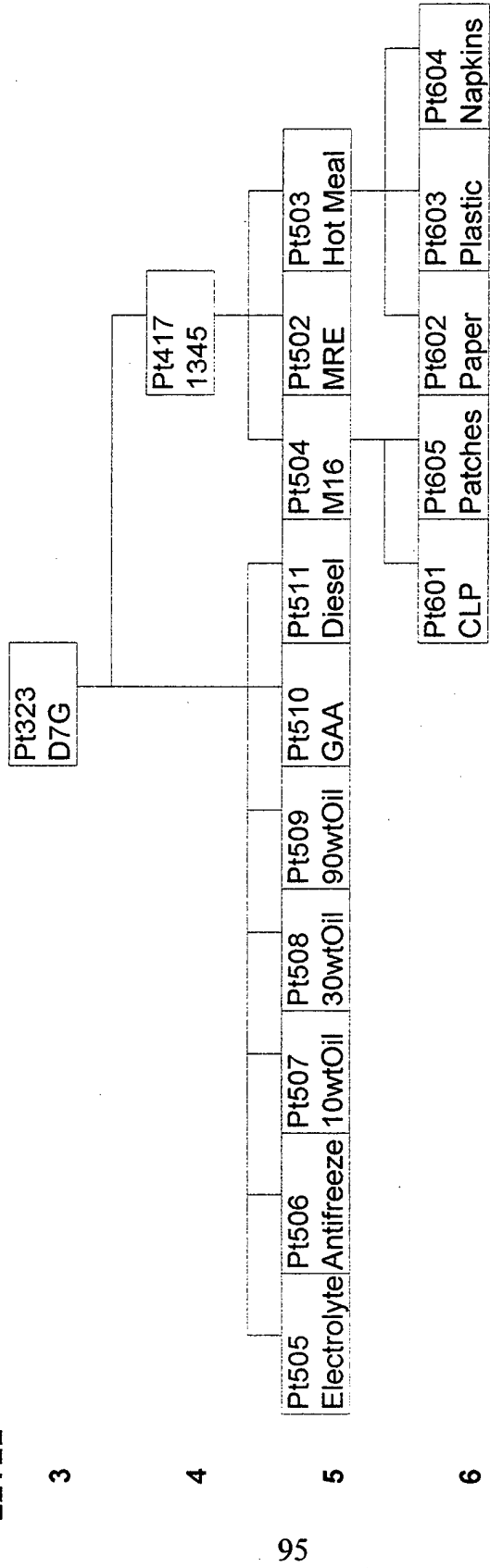

Third through sixth level subassemblies and component parts for Part 203, HE/MT Section.

LEVEL

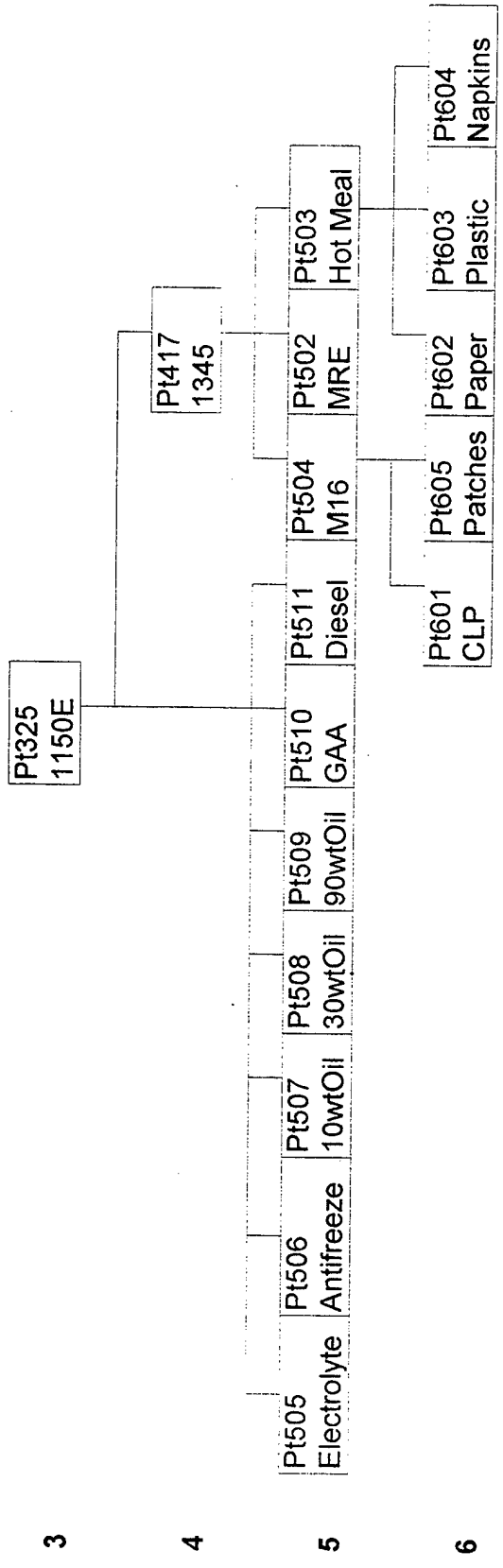

Third through sixth level subassemblies and component parts for Part 203, HE/MT Section.

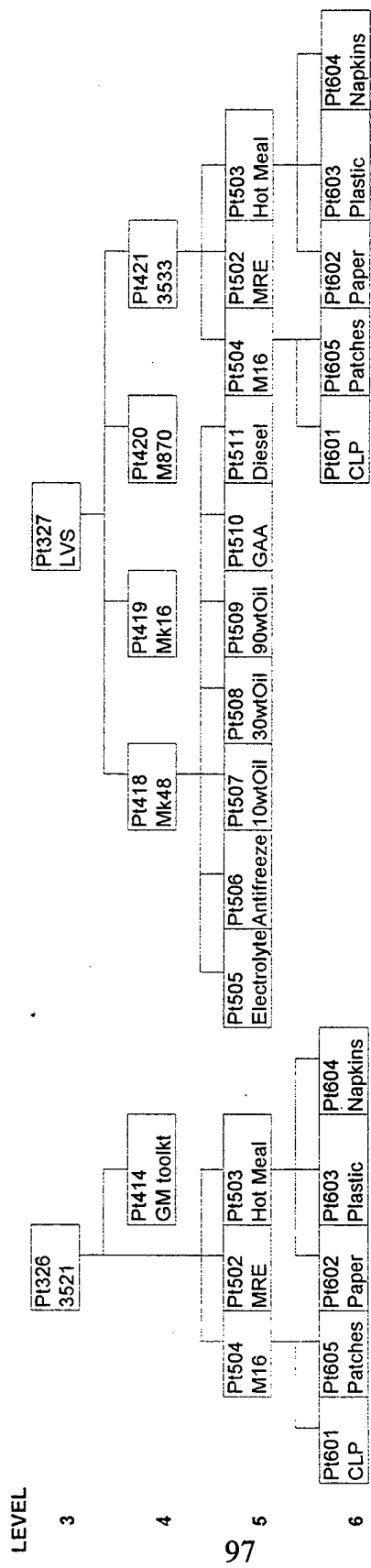

Third through sixth level subassemblies and component parts for Part 203, HE/MT Section.



LEVEL

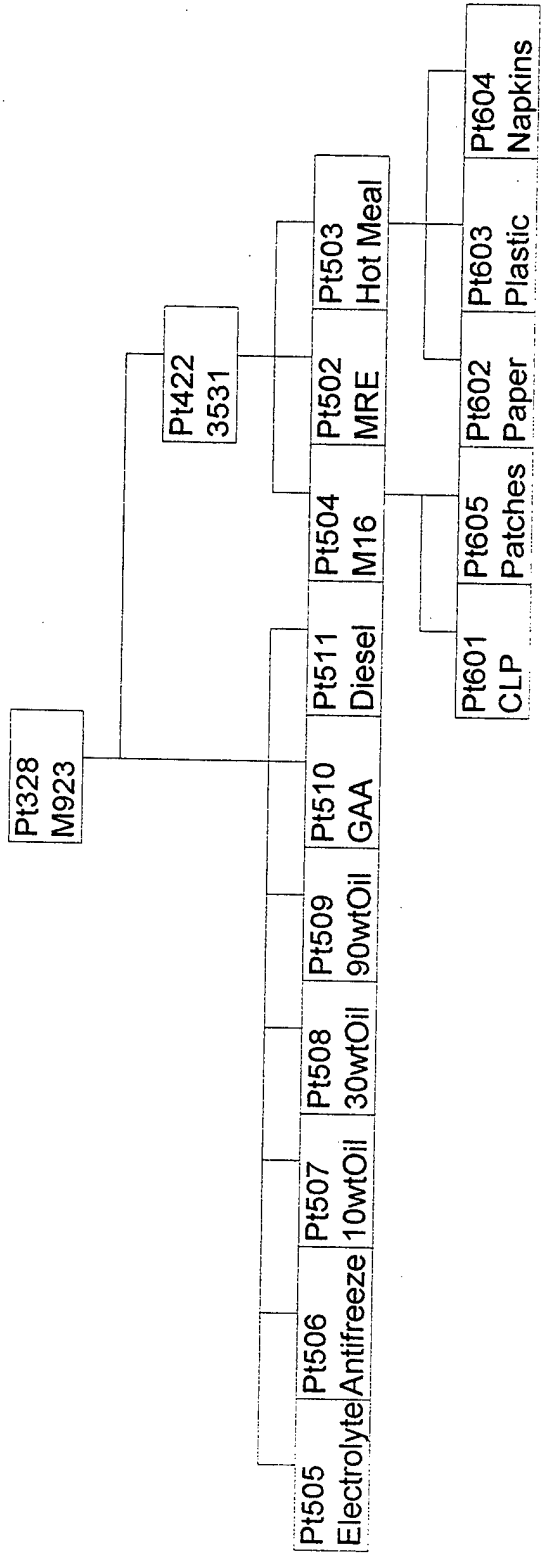

Third through sixth level subassemblies and component parts for Part 203, HE/MT Section.

LEVEL

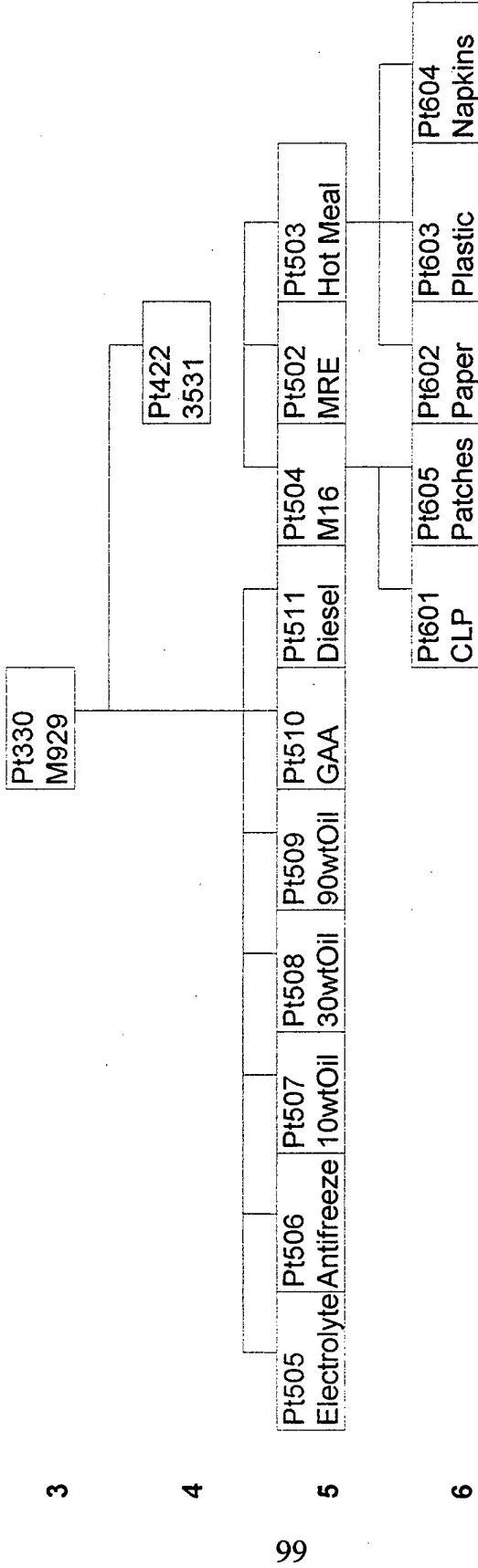

Third through sixth level subassemblies and component parts for Part 203, HE/MT Section.



## **APPENDIX B. TEMPLATE FORMULAS**

Important formulas for the various templates that make up the Training Exercise Material Requirements Planning Decision Support Model are included here.

Bill of Materials/ Inventory Status Record							
Component Part No./ Part Name	Quantity/ Parent Part No./ Part Name	Sub Total	Gross Reqmt.	Lead Time	On Hand Quantity		
101	Engineer Platoon		1	0	0		
201	Platoon Headquarters						
1	per 101 Engr Plt		+B33*F30	0	0		
202	Engineer Squad						
2	per 101 Engr Plt		+B36*F30	0	0		
203	Engr Equip./Motor T Section						
1	per 101 Engr Plt		+B39*F30	0	0		
301	Engr Officer/SNCO (1302/1371)						
1	per 201 Plt Hqtrs		+B42*F33	0	0		
302	Can, Water						
2	per 201 Plt Hqtrs		+B45*F33	0	8		
303	Combat Engineer (1371)						
1	per 201 Plt Hqtrs	+B48*F33					
1	per 202 Engr Sqd	+B49*F36					
			+E48+E49	0	0		
304	Night Vision Sight, AN/PVS-4						
1	per 201 Plt Hqtrs		+B53*F33	0	0		
305	Night Vis. Goggles, AN/PVS-5A						
2	per 201 Plt Hqtrs		+B56*F33	0	0		
306	Radio Operator (2531)						
1	per 201 Plt Hqtrs		+B59*F33	0	0		
307	Radio Set, PRC-77						
1	per 201 Plt Hqtrs	+B62*F33					
1	per 202 Engr Sqd	+B63*F36					
			+E62+E63	1	0		
308	Machine Gun, 7,62mm, M60E3						
2	per 201 Plt Hqtrs		+B67*F33	0	0		
309	Binoculars						
2	per 201 Plt Hqtrs		+B70*F33	0	2		
310	Truck, Utility, 1.25-ton, HMMWV						
1	per 201 Plt Hqtrs	+B73*F33					
1	per 202 Engr Sqd	+B74*F36					
			+E73+E74	0	0		
311	Tool Kit, Carpenter's, Engr Plt						
1	per 201 Plt Hqtrs		+B78*F33	0	1		
312	Minefield Marking Set						
0.5	per 201 Plt Hqtrs		+B81*F33	0	0		
313	Detecting Set, Mine, AF-108						
1	per 202 Engr Sqd		+B84*F36	0	0		
314	Launcher, Asslt Rocket, SMAW						
1	per 202 Engr Sqd		+B87*F36	0	0		
315	Machine Gun, SAW, M-249						
1	per 202 Engr Sqd		+B90*F36	0	0		
316	Tool Kit, Pioneer, Engr Squad						

A	A	B	C	D	E	F	G	H
93		1	per 202	Engr Sqd		+B93*F36	0	0
94								
95	317							
96		1	per 202	Engr Sqd		+B96*F36	0	0
97								
98	318							
99		1	per 202	Engr Sqd		+B99*F36	0	0
100								
101	319							
102		1	per 202	Engr Sqd		+B102*F36	2	3
103								
104	320							
105		2	per 203	HEMT Sct		+B105*F39	0	0
106								
107	321							
108		1	per 203	HEMT Sct		+B108*F39	1	0
109								
110	322							
111		2	per 203	HEMT Sct		+B111*F39	1	0
112								
113	323							
114		1	per 203	HEMT Sct		+B114*F39	1	0
115								
116	324							
117		1	per 203	HEMT Sct		+B117*F39	1	0
118								
119	325							
120		1	per 203	HEMT Sct		+B120*F39	1	0
121								
122	326							
123		2	per 203	HEMT Sct		+B123*F39	0	0
124								
125	327							
126		1	per 203	HEMT Sct		+B126*F39	1	0
127								
128	328							
129		1	per 203	HEMT Sct		+B129*F39	1	0
130								
131	329							
132		1	per 203	HEMT Sct		+B132*F39	1	0
133								
134	330							
135		1	per 203	HEMT Sct		+B135*F39	1	0
136								
137	401							
138		1	per 301	Off/SNCO		+B138*F42	0	0
139								
140	402							
141		1	per 301	Off/SNCO	+B141*F42			
142		1	per 202	Engr Sqd	+B142*F36			
143						+E141+E142	0	5
144								
145	403							
146		3	per 304	AN/PVS-4	+B146*F53			
147		3	per 305	AN/PVS-5A	+B147*F56			
148						@SUM(E146..E147)	3	6
149	404							
150		4	per 307	PRC-77		+B150*F64	3	10
151								
152	405							
153		1	per 308	M60E3		+B153*F67	0	0
154								
155	406							
156		2	per 312	MFM Set		+B156*F81	1	1
157								
158	407							
159		2	per 312	MFM Set		+B159*F81	1	2

A	A	B	C	D	E	F	G	H
160								
161	408	Cyalume Lightstick (Blue)						
162		2	per 312	MFM Set		+B162*F81	1	3
163								
164	409	Battery, BA-3030						
165		6	per 313	AF-108		+B165*F84	1	0
166								
167	410	Engineer Tape						
168		7	per 316	TIKt, Pion		+B168*F93	3	2
169								
170	411	Mogas						
171		Total	per 317	Saw, Chn	+T133		0	
172								
173	412	Electrical Tape						
174		2	per 318	Demo Eq		+B174*F99	0	7
175								
176	413	Detonating Cord Connectors						
177		10	per 318	Demo Eq		+B177*F99	4	75
178								
179	414	Tool Kit, General Mechanics						
180		1	per 320	HE Mech	+B180*F105			
181		1	per 326	MT Mech	+B181*F123			
182						+E180+E181	1	0
183								
184	415	Bucket, Scoop, TRAM						
185		1	per 321	TRAM		+B185*F108	1	0
186								
187	416	Forklift Attachment, TRAM						
188		1	per 321	TRAM		+B188*F108	1	0
189								
190	417	Engr Equip Operator (1345)						
191		1	per 321	TRAM	+B191*F108			
192		1	per 322	SEE	+B192*F111			
193		1	per 323	D7G	+B193*F114			
194		1	per 325	1150E	+B194*F120			
195						@SUM(E191..E194)	0	0
196								
197	418	Power Unit, Front, 12.5T, MK48						
198		1	per 327	LVS		+B198*F126	1	0
199								
200	419	Trailer, Semi, Pow, 5th Whl, MK16						
201		1	per 327	LVS		+B201*F126	1	0
202								
203	420	Trailer, Semi, Lowbed, 40T, M870						
204		1	per 327	LVS		+B204*F126	1	0
205								
206	421	Heavy Motor Veh. Oper. (3533)						
207		1	per 327	LVS		+B207*F126	0	0
208								
209	422	Motor Vehicle Operator (3531)						
210		1	per 328	M923	+B210*F129			
211		1	per 330	M929	+B211*F135			
212						@SUM(E210..E211)	0	0
213								
214	501	Patches, 7.62mm						
215		1	per 308	M60E3	+B215*F138			
216		1	per 401	Pistol, M9	+B216*F138			
217						@SUM(E215..E216)	3	
218								
219	502	Meal, Ready-to-Eat (MRE)						
220		+P61	per 301	Off/SNCO	+B220*F42			
221		+P61	per 303	1371	+B221*F50			
222		+P61	per 306	2531	+B222*F59			
223		+P61	per 320	1341	+B223*F105			
224		+P61	per 326	3521	+B224*F123			
225		+P61	per 417	1345	+B225*F195			
226		+P61	per 421	3533	+B226*F207			

A	B	C	D	E	F	G	H
227	+P61	per 422	3531	+B227*F212			
228					@SUM(E220..E227)	4	240
229							
230	503	Hot Meals					
231		+Q61 per 301	Off/SNCO	+B231*F42			
232		+Q61 per 303	1371	+B232*F50			
233		+Q61 per 306	2531	+B233*F59			
234		+Q61 per 320	1341	+B234*F105			
235		+Q61 per 326	3521	+B235*F123			
236		+Q61 per 417	1345	+B236*F195			
237		+Q61 per 421	3533	+B237*F207			
238		+Q61 per 422	3531	+B238*F212			
239					@SUM(E231..E238)	0	0
240							
241	504	Rifle, 5.56mm, M16A2					
242		1 per 303	1371	+B242*F50-F36			
243		1 per 306	2531	+B243*F59			
244		1 per 320	1341	+B244*F105			
245		1 per 326	3521	+B245*F123			
246		1 per 417	1345	+B246*F195			
247		1 per 421	3533	+B247*F207			
248		1 per 422	3531	+B248*F212			
249					@SUM(E242..E248)	0	0
250							
251	505	Electrolyte (Gal./ Part No.)					
252		0 per 310	HMMWV	+B252*F75			
253		0 per 321	TRAM	+B253*F108			
254		0 per 322	SEE	+B254*F111			
255		0 per 323	D7G	+B255*F114			
256		0 per 325	1150E	+B256*F120			
257		0 per 328	M923	+B257*F129			
258		0 per 330	M929	+B258*F135			
259		0 per 418	MK48	+B259*F198			
260					@SUM(E252..E259)	1	0
261							
262	506	Anti-Freeze (Gal./Part No.)					
263		0 per 310	HMMWV	+B263*F75			
264		0 per 321	TRAM	+B264*F108			
265		5 per 322	SEE	+B265*F111			
266		0 per 323	D7G	+B266*F114			
267		0 per 325	1150E	+B267*F120			
268		0 per 328	M923	+B268*F129			
269		5 per 330	M929	+B269*F135			
270		0 per 418	MK48	+B270*F198			
271					@SUM(E263..E270)	1	0
272							
273	507	10wtOil (Gal./ Part No.)					
274		0 per 310	HMMWV	+B274*F75			
275		0 per 321	TRAM	+B275*F108			
276		5 per 322	SEE	+B276*F111			
277		0 per 323	D7G	+B277*F114			
278		0 per 325	1150E	+B278*F120			
279		0 per 328	M923	+B279*F129			
280		0 per 330	M929	+B280*F135			
281		0 per 418	MK48	+B281*F198			
282					@SUM(E274..E281)	1	0
283							
284	508	30wtOil (Gal./ Part No.)					
285		0 per 310	HMMWV	+B285*F75			
286		0 per 321	TRAM	+B286*F108			
287		0 per 322	SEE	+B287*F111			
288		0 per 323	D7G	+B288*F114			
289		0 per 325	1150E	+B289*F120			
290		0 per 328	M923	+B290*F129			
291		0 per 330	M929	+B291*F135			
292		0 per 418	MK48	+B292*F198			
293					@SUM(E285..E292)		



A	B	C	D	E	F	G	H
294							
295	509	90wtOil (Gal./ Part No.)					
296		0 per 310	HMMWV	+B296*F75			
297		5 per 321	TRAM	+B297*F108			
298		10 per 322	SEE	+B298*F111			
299		0 per 323	D7G	+B299*F114			
300		0 per 325	1150E	+B300*F120			
301		0 per 328	M923	+B301*F129			
302		0 per 330	M929	+B302*F135			
303		0 per 418	MK48	+B303*F198			
304							
305					@SUM(E296..E303)		5
306	510	Grease; GAA (Lbs/ Part No.)					
307		0 per 310	HMMWV	+B307*F75			
308		0 per 321	TRAM	+B308*F108			
309		0 per 322	SEE	+B309*F111			
310		0 per 323	D7G	+B310*F114			
311		0 per 325	1150E	+B311*F120			
312		0 per 328	M923	+B312*F129			
313		0 per 330	M929	+B313*F135			
314		0 per 418	MK48	+B314*F198			
315					@SUM(E307..E314)		5
316							
317	511	Diesel Fuel					
318		Total per 310	HMMWV	+T123			
319		Total per 321	TRAM	+T95			
320		Total per 322	SEE	+T88			
321		Total per 323	D7G	+T81			
322		Total per 325	1150E	+T74			
323		Total per 328	M923	+T109			
324		Total per 330	M929	+T116			
325		Total per 418	MK48	+T102			
326					@SUM(E318..E326)		0
327							
328	512	40:1 Oil					
329		0 per 411	Mogas		+B329*F171		
330							16
331	601	CLP (Oz./ Part No.)					
332		0 per 308	M60E3	+B332*F67			
333		0 per 314	SMAW	+B333*F87			
334		0 per 315	SAW	+B334*F90			
335		0 per 401	Pistol, M9	+B335*F138			
336		0 per 504	M16A2	+B336*F249			
337					@SUM(E332..E336)		21
338							
339	602	Paperware					
340		1 per 503	Hot Meal		+B340*F239		
341							500
342	603	Plasticware					
343		1 per 503	Hot Meal		+B343*F239		
344							572
345	604	Napkins					
346		1 per 503	Hot Meal		+B346*F239		
347							500
348	605	Patches, 5.56mm					
349		1 per 315	SAW,	+B349*F90			
350		1 per 504	M16A2	+B350*F249			
351					@SUM(E349..E350)		67
352							
353		Component Part No./ Part Name		Sub Total	Gross Reqmt.	Lead Time	On Hand Quantity

26	A	K	L	M	N	O	P	Q
27		<b>Training Exercise/Deployment Information</b>						
28		Period Dates	From	To	No. Days			
29		Training Ex. Period	10/21/96	10/21/96	@DATEDIF(@DATEVALUE(M29),@DATEVALUE(N29),"d")+1			
30		Advance Party	10/22/96	10/23/96	@DATEDIF(@DATEVALUE(M30),@DATEVALUE(N30),"d")+1			
31		FEX	10/23/96	10/27/96	@DATEDIF(@DATEVALUE(M31),@DATEVALUE(N31),"d")+1			
32		Rear Party	10/27/96	10/28/96	@DATEDIF(@DATEVALUE(M32),@DATEVALUE(N32),"d")+1			
33								
34		<b>Milestone Events</b>		<b>Date</b>				
35								
36		Departure		+M29				
37		Mobile Load Equipment		10/25/96				
38		Tool Chests, Sets, Kits Inspect.		10/14/96				
39		HE/MT LTI		10/14/96				
40		Personnel Inspection		11/02/96				
41		All supplies received		10/23/96				
42		Equipment Attached		10/23/96				
43		Personnel Attached		11/02/96				
44		Submit T/O Strength		07/12/96				
45		Submit EDL		03/07/96				
46		Submit Class I Requirements		07/12/96				
47		Submit Class II Requirements		03/07/96				
48		Submit class III Requirements		03/07/96				
49								

50	<b>Class I: Subsistence Calculations per individual</b>						
51							
52							
53	Type Day	No. Days	Number of Meal per Day		Hot Meals	Total MRE	Total Hot
54			MRE				
55	Travel to Exercise	0	0		0		+M55*N55 +M55*O55
56	Training Days	+O29-O31-M55-M60	1		0		+M56*N56 +M56*O56
57	FEX first day	1	3		0		+M57*N57 +M57*O57
58	FEX days	+O31-M57-M59	3		0		+M58*N58 +M58*O58
59	FEX last day	1	2		1		+M59*N59 +M59*O59
60	Travel from Exercise	0	0		0		+M60*N60 +M60*O60
61						Total @SUM(P55..P60)	@SUM(Q55..Q60)

Class III: Petroleum, Oils and Lubricants Calculations									
TAMCN	Nomenclature	# Vehicles	Gal/Hr	Hrs/Day	No. Days	Gallons	Total		
B2460	Tractor, Full-Trk, Angle Blade, Case 1150E	4							
	Advance Party	0		0	+O30	+O70*P70*Q70*R70			
	Training Period	0	+SP70	0	+O29-O31-M55-M60	+O71*P71*Q71*R71			
+F120	FEX	1	+SP70	4	+O31	+O72*P72*Q72*R72			
	Rear Party	0	+SP70	0	+O32	+O73*P73*Q73*R73			
	Total								@SUM(S70, S73)
B2482	Tractor, Full-Trk, Medium, D7G	6							
	Advance Party	0		0	+O30	+O77*P77*Q77*R77			
	Training Period	0	+SP77	0	+O29-O31-M55-M60	+O78*P78*Q78*R78			
+F114	FEX	1	+SP77	0	+O31	+O79*P79*Q79*R79			
	Rear Party	0	+SP77	0	+O32	+O80*P80*Q80*R80			
	Total								@SUM(S77, S80)
B2482	Tractor, All Whl Dr, w/ Attach., SEE	4							
	Advance Party	0		0	+O30	+O84*P84*Q84*R84			
	Training Period	0	+SP84	0	+O29-O31-M55-M60	+O85*P85*Q85*R85			
+F111	FEX	1	+SP84	0	+O31	+O86*P86*Q86*R86			
	Rear Party	0	+SP84	0	+O32	+O87*P87*Q87*R87			
	Total								@SUM(S84, S87)
B2567	Tractor, Rubber Tire, Artic. Str, TRAM	4							
	Advance Party	0		0	+O30	+O91*P91*Q91*R91			
	Training Period	0	+SP91	0	+O29-O31-M55-M60	+O92*P92*Q92*R92			
+F108	FEX	1	+SP91	0	+O31	+O93*P93*Q93*R93			
	Rear Party	0	+SP91	0	+O32	+O94*P94*Q94*R94			
	Total								@SUM(S91, S94)
D0209	Power Unit, Front, 12.5-ton, MK48	16.66							
	Advance Party	0		0	+O30	+O98*P98*Q98*R98			
	Training Period	0	+SP98	0	+O29-O31-M55-M60	+O99*P99*Q99*R99			
+F198	FEX	1	+SP98	0	+O31	+O100*P100*Q100*R100			
	Rear Party	0	+SP98	0	+O32	+O101*P101*Q101*R101			
	Total								@SUM(S98, S101)
D1059	Truck, Cargo, 5-ton, M923	11.5							
	Advance Party	0		0	+O30	+O105*P105*Q105*R105			
	Training Period	0	+SP105	0	+O29-O31-M55-M60	+O106*P106*Q106*R106			
+F129	FEX	1	+SP105	0	+O31	+O107*P107*Q107*R107			
	Rear Party	0	+SP105	0	+O32	+O108*P108*Q108*R108			
	Total								@SUM(S105, S108)
D1072	Truck, Dump, 5-ton, M929	11.5							
	Advance Party	0		0	+O30	+O112*P112*Q112*R112			
	Training Period	0	+SP112	0	+O29-O31-M55-M60	+O113*P113*Q113*R113			
+F135	FEX	1	+SP112	0	+O31	+O114*P114*Q114*R114			
	Rear Party	0	+SP112	0	+O32	+O115*P115*Q115*R115			
	Total								@SUM(S112, S115)
D1158	Truck, Utility, 1.25-ton, HMMWV	1.7							
	Advance Party	0		0	+O30	+O119*P119*Q119*R119			
	Training Period	0	+SP119	0	+O29-O31-M55-M60	+O120*P120*Q120*R120			
+F75	FEX	1	+SP119	0	+O31	+O121*P121*Q121*R121			
	Rear Party	0	+SP119	0	+O32	+O122*P122*Q122*R122			
	Total								@SUM(S119, S122)
Bulk Fuel - Mogas									
TAMCN	Nomenclature	Gal/Hr	Hrs/Day	No. Days	Gallons	Total			
B1830	Saw, Chain, One-Man Portable	0.5							
	Advance Party	0		0	+O30	+O129*P129*Q129*R129			
	Training Period	0	+SP129	0	+O29-O31-M55-M60	+O130*P130*Q130*R130			
+F86	FEX	3	+SP129	0	+O31	+O131*P131*Q131*R131			
	Rear Party	0	+SP129	0	+O32	+O132*P132*Q132*R132			
	Total								@SUM(S129, S132)
Packaged Petroleum Products									
NSN	Nomenclature	Unit Issue	Qty.	Req. Qty					
6810-00-249-9354	Electrolyte	GI	+F260	0					
6850-00-181-7929	Anti-Freeze	1-GI Bt	+F271	0					
6850-00-181-7933	Anti-Freeze	5-GL CN	+F271/5	0					
6850-00-181-7940	Anti-Freeze	55-GI Dr	+F271/55	0					
9150-00-189-6727	Lube Oil, 10wt	1-Qt Cn	+F282*4	0					
9150-00-186-6868	Lube Oil, 10wt	5-GI Cn	+F282/5	0					
9150-00-191-2772	Lube Oil, 10wt	55-GI Dr	+F282/55	0					
9150-00-186-6681	Lube Oil, 30wt	1-Qt Cn	+F293*4	0					
9150-00-188-9858	Lube Oil, 30wt	5-GI Cn	+F293/5	0					
9150-00-189-6729	Lube Oil, 30wt	55-GI Dr	+F293/55	0					
9150-00-035-5392	Lube Oil, 90wt	1-Qt Cn	+F304*4	0					
9150-00-035-5393	Lube Oil, 90wt	5-GI Cn	+F304/5	0					
9150-00-035-5394	Lube Oil, 90wt	55 GI Dr	+F304/55	0					
9150-00-190-0905	Grease, GAA	6.5-Lb Cn	+F315/6.5	0					
9150-00-190-0907	Grease, GAA	35-Lb Cn	+F315/35	0					
9150-01-053-6688	CLP	GI	+F337/128	0					
9150-01-054-6453	CLP	Pl	+F337/16	0					

A B C D E F G

### Training Exercise Material Requirements Planning

Part No: 101  
 Part Name: COMBAT ENGINEER PLATOON (REIN)

Customer	TEEP No.	Qty	Due Date	Backlog	Week 1	Week 2
2Bn/23Mar	56-007	+F30	+M29	@IF(D9>0#AND#D9<F8,C9,"")	@TODAY-@MOD(@WEEKDAY(@TODAY),7) @IF(D9<G8#AND#D9>=F8,\$C9,"")	@IF(D9<H8#AND#D9>=G8,\$C9,"")
Scheduled Return:				City	+F8	+G8
				+F30	@IF(\$D13<G\$12#AND#\$D13>=F\$12,\$C13,"")	@IF(\$D13<H\$12#AND#\$D13>=G\$12,\$C13,"")
On Hand		+H30	+D16*E13-E9		+E16*F13-F9	+F16+G13-G9
Planned Order Release			@IF(@INDEX(E16..R16,J4,0,0)<0,J3-D16,0)	@IF(@INDEX(F16..R16,J4,0,0)*E17<0,J3-D16,0)	@IF(@INDEX(G16..R16,J4,0,0)*@SUM(E17..F17)<0,J3-D16,0)	

Remarks:

A H I J

Lot-for-Lot= +F30  
LT= +G30

3				5
4	+G8+7		+H8+7	+I8+7
5	@IF(\$D9<=\$B#AND#\$D9>=\$B8,\$C9,"")	@IF(\$D9<=\$B#AND#\$D9>=\$B8,\$C9,"")	@IF(\$D9<=\$B#AND#\$D9>=\$B8,\$C9,"")	@IF(\$D9<=\$B#AND#\$D9>=\$B8,\$C9,"")
6	+H8	+I8	+J8	+K8
7	@IF(\$D13<=\$I2#AND#\$D13>=\$I12,\$C13,"")	@IF(\$D13<=\$I2#AND#\$D13>=\$I12,\$C13,"")	@IF(\$D13<=\$I2#AND#\$D13>=\$I12,\$C13,"")	@IF(\$D13<=\$I2#AND#\$D13>=\$I12,\$C13,"")
8	+G16+H13+H9	+H16+I13+J9	+I16+J13+K9	+J16+K13+L9
9	@IF(@INDEX(H16,\$R16,\$J4,0,0)+@SUM(\$E17..G17)<0,\$J3,\$D16,0)	@IF(@INDEX(I16,\$R16,\$J4,0,0)+@SUM(\$E17..H17)<0,\$J3,\$D16,0)	@IF(@INDEX(J16,\$R16,\$J4,0,0)+@SUM(\$E17..I17)<0,\$J3,\$D16,0)	@IF(@INDEX(K16,\$R16,\$J4,0,0)+@SUM(\$E17..J17)<0,\$J3,\$D16,0)

M

L

K

A

week(s)

1						
2						
3						
4						
5						
6						
7						
8						
9		6				
10		+I8+7				
11						
12			7			
13			+K8+7			
14						
15						
16						
17						
18						
19						
20						
21						
22						
23						

1			
2			
3			
4			
5			
6			
7			
8	9	10	11
9	+M8*7	+N8*7	+O8*7
10	@IF(\$D9<O8#AND#D9>=N88,\$C9""	@IF(\$D9<P8#AND#D9>=O88,\$C9""	@IF(\$D9<Q8#AND#D9>=P88,\$C9""
11			
12	+N8	+O8	+P8
13	@IF(\$D13<O812#AND#D13>=N812,\$C13""	@IF(\$D13<P812#AND#D13>=O812,\$C13""	@IF(\$D13<Q812#AND#D13>=P812,\$C13""
14			
15	+M16*N13*N9	+N16*O13*O8	+O16*P13*P9
16	@IF(@INDEX(N16,\$R16,\$J4,0)+@SUM(\$E17..M17)<O,\$J3-\$D16,0)	@IF(@INDEX(O16,\$R16,\$J4,0)+@SUM(\$E17..N17)<O,\$J3-\$D16,0)	@IF(@INDEX(P16,\$R16,\$J4,0)+@SUM(\$E17..O17)<O,\$J3-\$D16,0)
17			
18			
19			
20			
21			
22			
23			

A

Q

1  
2  
3  
4  
5  
6  
7  
8  
9  
10  
11  
12  
13  
14  
15  
16  
17  
18  
19  
20  
21  
22  
23



R



C A B C D E F  
 138 Part No: 308  
 139 Part Name: MACHINE GUN, 7.62MM, M60E3

Exercise Support Requirements:

Qty per	Part No.	Backlog	Week 1
+PART 101:B67	+PART 101:C67	+200 LEVEL:ES13	@TODAY @MOD@WEEKDAY(@TODAY),7
Total Requirements		+SC143*E143	+200 LEVEL:F513 +SC143*F143
On Hand	+PART 101:H67	+D146-E144	+E146-F144
Planned Order Releases		@IF@INDEX(E146..R146..J139,0,0)<0,J138-D146,0	@IF@INDEX(F146..R146..J139,0,0)+E147<0,J138-D146,0

REMARKS:

H

G

C

138  
139  
140  
141  
142  
143  
144  
145  
146  
147  
148  
149  
150  
151  
152  
153

	2	+F142+7		3	+G142+7
+200 LEVEL.G\$13			+200 LEVEL.H\$13		
+\$C143*G143			+\$C143*H143		
+F146-G144			+G146-H144		
@IF(@INDEX(G146,\$R146,\$J139,0,0)+@SUM(\$E147..F147)<0,\$J138-\$D146,0)		@SUM(\$E147..F147)<0,\$J138-\$D146,0)	@IF(@INDEX(H146,\$R146,\$J139,0,0)+@SUM(\$E147..G147)<0,\$J138-\$D146,0)		

C  
138  
139  
140  
141  
142  
143  
144  
145  
146  
147  
148  
149  
150  
151  
152  
153

Lot-for-Lot= +PART 101:F67  
LT= +PART 101:G67

	I	J
	4	5
	+H142*7	+H142*7
+200 LEVEL:\$13		+200 LEVEL:\$13
*\$C143*143		*\$C143*143
+H146-1144		+H146-1144
@IF(@INDEX(1146,\$R146,\$J139,0,0)*@SUM(\$E147..H147)<0,\$I138-\$D146,0)		@IF(@INDEX(J146,\$R146,\$J139,0,0)*@SUM(\$E147..I147)<0,\$I138-\$D146,0)

C

K

L

138  
139  
140  
141  
142  
143  
144  
145  
146  
147  
148  
149  
150  
151  
152  
153

week(s)

	6	7
	+J142*7	+K142*7
	+200 LEVEL.K\$13	+200 LEVEL.L\$13
	+\$C143*K143	+\$C143*L143
	+J146-K144	+K146-L144
	@IF(@INDEX(K146,\$J139:0.0)*@SUM(\$E147..J147)>0,\$J138-\$D146:0)	@IF(@INDEX(L146,\$R146,\$J139:0.0)*@SUM(\$E147..K147)<0,\$J138-\$D146:0)

C  
 138  
 139  
 140  
 141  
 142  
 143  
 144  
 145  
 146  
 147  
 148  
 149  
 150  
 151  
 152  
 153

M

N

	8	9
	+L142+7	+M142+7
+200 LEVEL.M\$13		+200 LEVEL.N\$13
+\$C143*M143		+\$C143*N143
+L148-M144		+M148-N144
@IF(@INDEX(M146,\$R146:\$J139,0,0)+@SUM(\$E147:L147)<0,\$J138-\$D146,0)		@IF(@INDEX(N146,\$R146:\$J139,0,0)+@SUM(\$E147:M147)<0,\$I38-\$D146,0)

C  
 138  
 139  
 140  
 141  
 142  
 143  
 144  
 145  
 146  
 147  
 148  
 149  
 150  
 151  
 152  
 153

O

P

	10	11
	+N142*7	+O142*7
+200 LEVEL:O\$13	+200 LEVEL:P\$13	
+\$C143*O143	+\$C143*P143	
+N146-O144	+O146-P144	
@IF(@INDEX(O146,\$R146,\$J139,0,0)+@SUM(\$E147..N147)<0,\$J138-\$D146,0)	@IF(@INDEX(P146,\$R146,\$J139,0,0)+@SUM(\$E147..O147)<0,\$J38-\$D146,0)	

C  
138  
139  
140  
141  
142  
143  
144  
145  
146  
147  
148  
149  
150  
151  
152  
153

Q

R

	12	Future
	+P142+7	+Q142+7
+200 LEVEL Q\$13		+200 LEVEL R\$13
+\$C143*Q143		+\$C143*R143
+P146-Q144		+Q146-R144
@IF(@INDEX(Q146..\$R146.\$J139:0,0)+@SUM(\$E147..F147)<0,\$J138,\$D146,0)		@IF(@INDEX(R146..\$R146.\$J139:0,0)+@SUM(\$E147..Q147)<0,\$J38,\$D146,0)

F A B C D E F

600 LEVEL "PARTS"

Part No: 601  
 Part Name: CLEANING, LUBRICATING, PRESERV.

Exercise Support Requirements:

Qty Per	Part No.	Backlog	Week 1
+PART 101:B332	+PART 101:C332	+300 LEVEL:E147	@ TODAY @MOD@WEEKDAY(@TODAY),7
+PART 101:B333	+PART 101:C333	+300 LEVEL:E262	+300 LEVEL:F147
+PART 101:B334	+PART 101:C334	+300 LEVEL:E281	+300 LEVEL:F287
+PART 101:B335	+PART 101:C335	+400 LEVEL:E12	+300 LEVEL:F281
+PART 101:B336	+PART 101:C336	+500 LEVEL:E105	+400 LEVEL:F12
Total Requirements	(\$C\$9*E9)+(\$C\$9*E10)+(\$C\$11*E11)+(\$C\$12*E12)		(\$C\$9*F9)+(\$C\$10*F10)+(\$C\$11*F11)+(\$C\$12*F12)

Outstanding Orders:

Order Date	Qty	Due Date
09/31/66	0	1/7/76
09/30/66	0	1/7/76

On Hand Quantity:

[PART 101:H337	@IF(D21>0, *D21+E19-E13+E19-E13)
Planned Order Releases:	@IF(@INDEX(E21, \$R21, \$A, 0, 0) = 0, @ABS(@INDEX(E21, \$R21, \$A, 0, 0)), 0)
	@IF(@INDEX(F21, \$R21, \$A, 0, 0) = 0, @ABS(@INDEX(F21, \$R21, \$A, 0, 0)), 0)

REMARKS:

000 QUANTITIES UNDEDICATED, CAN BE USED TO SUPPORT THIS EXERCISE



F

G

H

1

2

3

4

5

6

7

8

9

10

11

12

13

14

15

16

17

18

19

20

21

22

23

24

25

26

27

28

		2		3
	+F7*7		+G7*7	
	+300 LEVEL.G147		+300 LEVEL.H147	
	+300 LEVEL.G262		+300 LEVEL.H262	
	+300 LEVEL.G281		+300 LEVEL.H281	
	+400 LEVEL.G12		+400 LEVEL.H12	
	+500 LEVEL.G105		+500 LEVEL.H105	
	((\$C8*G9)*(\$C9*G9)+(\$C10*G10)+(\$C11*G11)+(\$C12*G12))		(\$C8*H8)*(\$C9*H9)+(\$C10*H10)+(\$C11*H11)+(\$C12*H12)	

	+F18*7		+G16*7	
	@IF(\$D17<H16#AND#\$D17>=G16.\$C17,"")		@IF(\$D17<H16#AND#\$D17>=H16.\$C17,"")	
	@IF(\$D18<H16#AND#\$D18>=G16.\$C18,"")		@IF(\$D18<H16#AND#\$D18>=H16.\$C18,"")	
	@SUM(G17..G18)		@SUM(H17..H18)	

	@IF(F21=0+F21*G19-G13+G19-G13)		@IF(G21>0*G21+H19-H13+H19-H13)	
	@IF(@INDEX(G21..\$R21,\$J4,0)<0,@ABS(@INDEX(G21..\$R21,\$J4,0)),0)		@IF(@INDEX(H21..\$R21,\$J4,0)<0,@ABS(@INDEX(H21..\$R21,\$J4,0)),0)	

F 1  
2  
3  
4  
5  
6  
7  
8  
9  
10  
11  
12  
13  
14  
15  
16  
17  
18  
19  
20  
21  
22  
23  
24  
25  
26  
27  
28

I

J

Lot-for-Lot= +PART 101:F337  
LT= +PART 101:G337

		4	5
	+H7*7	+H7*7	+I7*7
	+300 LEVEL:J147	+300 LEVEL:J147	+300 LEVEL:J147
	+300 LEVEL:J262	+300 LEVEL:J262	+300 LEVEL:J262
	+300 LEVEL:J281	+300 LEVEL:J281	+300 LEVEL:J281
	+400 LEVEL:J12	+400 LEVEL:J12	+400 LEVEL:J12
	+500 LEVEL:J105	+500 LEVEL:J105	+500 LEVEL:J105
	(\$C\$8*J10)+(\$C\$9*J9)+(\$C\$10*J10)+(\$C\$11*J11)+(\$C\$12*J12)	(\$C\$8*J10)+(\$C\$9*J9)+(\$C\$10*J10)+(\$C\$11*J11)+(\$C\$12*J12)	(\$C\$8*J10)+(\$C\$9*J9)+(\$C\$10*J10)+(\$C\$11*J11)+(\$C\$12*J12)
	+H16*7	+H16*7	+H16*7
	@IF(\$D17<J16#AND#\$D17>=I16,\$C17,"")	@IF(\$D17<K16#AND#\$D17>=J16,\$C17,"")	@IF(\$D17<K16#AND#\$D17>=J16,\$C17,"")
	@IF(\$D18<J16#AND#\$D18>=I16,\$C18,"")	@IF(\$D18<K16#AND#\$D18>=J16,\$C18,"")	@IF(\$D18<K16#AND#\$D18>=J16,\$C18,"")
	@SUM(I17..J18)	@SUM(J17..J18)	@SUM(J17..J18)
	@IF(H21>0,H21+I19+J13+I19+J13)	@IF(I21>0,I21+J19+J13+J19+J13)	@IF(I21>0,I21+J19+J13+J19+J13)
	@IF(@INDEX(I21..SR21,\$J4,0,0)<0,@ABS(@INDEX(I21..SR21,\$J4,0,0)),0)	@IF(@INDEX(J21..SR21,\$J4,0,0)<0,@ABS(@INDEX(J21..SR21,\$J4,0,0)),0)	@IF(@INDEX(J21..SR21,\$J4,0,0)<0,@ABS(@INDEX(J21..SR21,\$J4,0,0)),0)

1  
2  
3  
4  
5  
6  
7  
8  
9  
10  
11  
12  
13  
14  
15  
16  
17  
18  
19  
20  
21  
22  
23  
24  
25  
26  
27  
28

F

K

L

week(s)

	6	7		
	+J7+7	+K7+7		
	+300 LEVEL:K147	+300 LEVEL:L147		
	+300 LEVEL:K262	+300 LEVEL:L262		
	+300 LEVEL:K281	+300 LEVEL:L281		
	+400 LEVEL:K12	+400 LEVEL:L12		
	+500 LEVEL:K105	+500 LEVEL:L105		
	(\$C\$8*K8)*(\$C\$9*K9)+(\$C\$10*K10)+(\$C\$11*K11)+(\$C\$12*K12)	(\$C\$8*L8)*(\$C\$9*L9)+(\$C\$10*L10)+(\$C\$11*L11)+(\$C\$12*L12)		
	+J16+7	+K16+7		
	@IF(\$D17<L16#AND#\$D17>=K16,\$C17,"")	@IF(\$D17<M16#AND#\$D17>=L16,\$C17,"")		
	@IF(\$D18<L16#AND#\$D18>=K16,\$C18,"")	@IF(\$D18<M16#AND#\$D18>=L16,\$C18,"")		
	@SUM(K7..K18)	@SUM(L7..L18)		
	@IF(J21>0,+J21+K19-K13,K19-K13)	@IF(K21>0,+K21+L19-L13,L19-L13)		
	@IF(@INDEX(K21..\$R21,\$J4,0,0)<0,@ABS(@INDEX(K21..\$R21,\$J4,0,0)),0)	@IF(@INDEX(L21..\$R21,\$J4,0,0)<0,@ABS(@INDEX(L21..\$R21,\$J4,0,0)),0)		

F M N

1  
2  
3  
4  
5  
6  
7  
8  
9  
10  
11  
12  
13  
14  
15  
16  
17  
18  
19  
20  
21  
22  
23  
24  
25  
26  
27  
28

				9
				+M7+7
				+300 LEVEL:M147
				+300 LEVEL:N262
				+300 LEVEL:N281
				+400 LEVEL:N12
				+500 LEVEL:N105
				(@C\$8*M8)*(\$C\$9*M9)*(\$C\$10*M10)*(\$C\$11*N11)*(\$C\$12*N12)
				+M16+7
				@IF(\$D17<N16#AND#\$D17>=N16,\$C17, "")
				@IF(\$D18<N16#AND#\$D18>=N16,\$C18, "")
				@SUM(N17..N18)
				@IF(L21>0, L21*M19-M13, +M19-M13)
				@IF(@INDEX(M21..\$R21,\$J4,0,0)<0,@ABS(@INDEX(M21..\$R21,\$J4,0,0)),0)

P

O

F

- 1
- 2
- 3
- 4
- 5
- 6
- 7
- 8
- 9
- 10
- 11
- 12
- 13
- 14
- 15
- 16
- 17
- 18
- 19
- 20
- 21
- 22
- 23
- 24
- 25
- 26
- 27
- 28

	10	11
	+N7*7	+O7*7
	+300 LEVEL.O147	+300 LEVEL.P147
	+300 LEVEL.O262	+300 LEVEL.P262
	+300 LEVEL.O281	+300 LEVEL.P281
	+400 LEVEL.O12	+400 LEVEL.P12
	+500 LEVEL.O105	+500 LEVEL.P105
	(\$C\$8*O8)+(\$C\$9*O9)+(\$C\$10*O10)+(\$C\$11*O11)+(\$C\$12*O12)	(\$C\$8*P8)+(\$C\$9*P9)+(\$C\$10*P10)+(\$C\$11*P11)+(\$C\$12*P12)
	+N16*7	+O16*7
	@IF(\$D17<P16#AND#\$D17>=O16,\$C17,"")	@IF(\$D17<O16#AND#\$D17>=P16,\$C17,"")
	@IF(\$D18<P16#AND#\$D18>=O16,\$C18,"")	@IF(\$D18<O16#AND#\$D18>=P16,\$C18,"")
	@SUM(O17..O18)	@SUM(P17..P18)
	@IF(N21>O+N21*O19-O13+O19-O13)	@IF(O21>O+O21*O19-P13+P19-P13)
	@IF(@INDEX(O21..\$R21,\$J4,0,0)<0,@ABS(@INDEX(O21..\$R21,\$J4,0,0)),0)	@IF(@INDEX(P21..\$R21,\$J4,0,0)<0,@ABS(@INDEX(P21..\$R21,\$J4,0,0)),0)

R

Q

F

1  
2  
3  
4  
5  
6  
7  
8  
9  
10  
11  
12  
13  
14  
15  
16  
17  
18  
19  
20  
21  
22  
23  
24  
25  
26  
27  
28

		12	Future
	+P7*7		+Q7*7
	+300 LEVEL:Q147		+300 LEVEL:R147
	+300 LEVEL:Q262		+300 LEVEL:R262
	+300 LEVEL:Q281		+300 LEVEL:R281
	+400 LEVEL:Q12		+400 LEVEL:R12
	+500 LEVEL:Q105		+500 LEVEL:R105
	((\$C\$9*Q9)+(\$C\$10*Q10)+(\$C\$11*Q11)+(\$C\$12*Q12)		((\$C\$9*R9)+(\$C\$10*R10)+(\$C\$11*R11)+(\$C\$12*R12)

	+P16*7		+Q16*7
	@IF(\$D17<R16#AND#\$D17>=Q16,\$C17,"")		@IF(\$D17<R16#AND#\$D17>=R16,\$C17,"")
	@IF(\$D18<R16#AND#\$D18>=Q16,\$C18,"")		@IF(\$D18<R16#AND#\$D18>=R16,\$C18,"")
	@SUM(Q17..Q18)		@SUM(R17..R18)
	@IF(P21>0,+P21+Q19-Q13+Q19-Q13)		@IF(Q21>0,+Q21+R19-R13+R19-R13)
	@IF(@INDEX(Q21..SR21,\$J4,0)<0,@ABS(@INDEX(Q21..SR21,\$J4,0)),0)		@IF(@INDEX(R21..SR21,\$J4,0)<0,@ABS(@INDEX(R21..SR21,\$J4,0)),0)

Unit	MOS	Quantity	Quantity
<b>Table of Organization</b>			
Cbt Engr Platoon	+F30		
Platoon Headquarters	+F33		
	1302/1371SNCO	+F42	
	1371	+E48	
	2531	+F59	
Engineer Squad	+F36		
	1371	+E49	
HE/MT Section	+F39		
	1341	+F105	
	1345	+F195	
	3521	+F123	
	3531	+F212	
	3533	+F207	
Total			@SUM(Y34..Y46)

TAMCN	Nomenclature	Quantity
A2050	Radio Set, PRC-77	+F64
B0215	Bucket, Scoop, TRAM	+F185
B0471	Demolition Equipment, Engineer Sqd	+F99
B0475	Detecting Set, Mine, Metallic, AF-108	+F84
B0647	Forklift Attachment, TRAM	+F188
B1298	Line Charge Launch Kit, Trailer-Mounted	+F117
B1320	Minefield Marking Set	+F81
B1830	Saw, Chain, One-Man Portable	+F96
B2210	Tool Kit, Carpenter's, Engineer Platoon	+F78
B2260	Tool Kit, Pioneer, Engineer Squad	+F93
B2460	Tractor, Full-Track, w/ Angled Blade, Case 1150E	+F120
B2462	Tractor, Full-Track, Medium, D7G	+F114
B2482	Tractor, All Wheel Drive, w/ Attachments, SEE	+F111
B2567	Tractor, Rubber Tired, Articulated Steering, TRAM	+F108
C4436	Can, Water	+F45
C6490	Tool Kit, General Mechanics	+F182
D0209	Power Unit, Front, 12.5-ton, MK48	+F198
D0235	Trailer, Semi-, Lowbed, 40-ton, M870	+F204
D0860	Trailer, Cargo, 1.5-ton, 2-Wheel, M105	+F132
D0878	Trailer, Semi-, Powered, 5th Wheel, MK16	+F201
D1059	Truck, Cargo, 5-ton, M923	+F129
D1072	Truck, Dump, 5-ton, M929	+F135
D1158	Truck, Utility, 1.25-ton, HMMWV	+F75
E0915	Launcher, Assault Rocket, 83mm, SMAW	+F87
E0960	Machine Gun, Light, Squad, Automatic, SAW, M-249	+F90
E0993	Machine Gun, 7.62mm, M60E3	+F67
E1120	Mount, Tripod, Machine Gun, 7.62mm, M-122	+F153
E1151	Night Vision Goggles, Individual, AN/PVS-5A	+F56
E1158	Night Vision Sight, Individual Served Weapon, AN/PVS-4	+F53
E1250	Pistol, 9mm, Semiautomatic, M-9	+F138
E1441	Rifle, 5.56mm, M16A2	+F249
K4222	Compass	+F143
N6001	Binoculars	+F70

A V W X Y Z AA AB AC

NSN	Nomenclature	Unit Issue	Quantity
1005-00-288-3565	Patches, 7.62	Pg	+F217
1005-00-912-4248	Patches, 5.56	Pg	+F351
5790-00-816-6056	Tape, Electrical	Ro	+F174
6135-00-930-0030	Battery, BA-3030	Pg	+F165/12
6135-01-034-2239	Battery, BA-5598	Ea	+F150
6135-01-090-5365	Battery, BA-5567/U	Ea	+F148
6260-01-074-4229	Cyalume, LtStk, Yellow	Bx	+F156
6260-01-178-5559	Cyalume, LtStk, Red	Bx	+F159
6260-01-178-5560	Cyalume, LtStk, Blue	Bx	+F162
6810-00-249-9354	Electrolyte	Gl	+Q138
6850-00-161-6204	Camouflage Stick	Ea	+F102
6850-00-181-7929	Anti-Freeze	1-Gl Bt	+Q141
6850-00-181-7933	Anti-Freeze	5-Gl Cn	+Q142
6850-00-181-7940	Anti-Freeze	55-Gl Dr	+Q143
7340-00-022-1315	Fork, Plastic	Hd	@ROUNDUP(+F343/100)
7340-00-022-1317	Spoon, Plastic	Hd	@ROUNDUP(+F343/100)
7340-00-022-1316	Knife, Plastic	Hd	@ROUNDUP(+F343/100)
7350-00-290-0593	Plate, Paper	Bx	@ROUNDUP(+F340/1000)
7350-00-456-2024	Cup, Paper	Bx	@ROUNDUP(+F340/2000)
8540-00-276-7569	Napkin, Paper	Bx	@ROUNDUP(+F346/6000)
8315-00-255-7662	Engineer Tape	Ro	+F168
9140-00-273-2377	Diesel Fuel	Gl	+F326
9150-00-189-6727	Lube Oil, 10wt	1-Qt Cn	+Q146
9150-00-186-6668	Lube Oil, 10wt	Cn	+Q147
9150-00-191-2772	Lube Oil, 10wt	55-Gl Dr	+Q148
9150-00-186-6681	Lube Oil, 30wt	1-Qt Cn	+Q151
9150-00-188-9858	Lube Oil, 30wt	5-Gl Cn	+Q152
9150-00-189-6729	Lube Oil, 30wt	Dr	+Q153
9150-01-035-5392	Lube Oil, 90wt	1-Qt Cn	+Q156
9150-01-035-5395	Lube Oil, 90wt	5-Gl Cn	+Q157
9150-00-035-5393	Lube Oil, 90wt	55 Gl Dr	+Q158
9150-00-190-0905	Grease, GAA	6.5-Lb Cn	+Q161
9150-00-190-0907	Grease, GAA	Cn	+Q162
9150-00-053-6688	CLP	Gl	+Q164
9150-00-054-6453	CLP	Pt	+Q165

NSN	Nomenclature	Unit Issue	Unit Price	Quantity	Total Price
1005-00-288-3565	Patches, 7.62	Pg	9.89	+F217	+AA148*AB148
1005-00-912-4248	Patches, 5.56	Pg	3.97	+F351	+AA149*AB149
5790-00-816-6056	Tape, Electrical	Ro	1.23	+F174	+AA150*AB150
6135-00-930-0030	Battery, BA-3030	Pg	12.25	+F165/12	+AA151*AB151
6135-01-034-2239	Battery, BA-5598	Ea	40.04	+F150	+AA152*AB152
6135-01-090-5365	Battery, BA-5567/U	Ea	5.21	+F148	+AA154*AB154
6260-01-074-4229	Cyalume, LtStk, Yellow	Bx	6.48	+F156	+AA155*AB155
6260-01-178-5559	Cyalume, LtStk, Red	Bx	6.2	+F159	+AA156*AB156
6260-01-178-5560	Cyalume, LtStk, Blue	Bx	6.48	+F162	+AA157*AB157
6810-00-249-9354	Electrolyte	Gl	2.9	+Q138	+AA158*AB158
6850-00-161-6204	Camouflage Stick	Ea	0.59	+F102	+AA160*AB160
6850-00-181-7929	Anti-Freeze	1-Gl Bt	5.3	+Q141	+AA161*AB161
6850-00-181-7933	Anti-Freeze	5-Gl Cn	0	+Q142	+AA162*AB162
6850-00-181-7940	Anti-Freeze	55-Gl Dr	220.12	+Q143	+AA163*AB163
7340-00-022-1315	Fork, Plastic	Hd	2.9	@ROUNDUP(+F343/100)	+AA164*AB164
7340-00-022-1317	Spoon, Plastic	Hd	2.63	@ROUNDUP(+F343/100)	+AA166*AB166
7340-00-022-1316	Knife, Plastic	Hd	3.16	@ROUNDUP(+F343/100)	+AA167*AB167
7350-00-290-0593	Plate, Paper	Bx	25.88	@ROUNDUP(+F340/1000)	+AA168*AB168
7350-00-456-2024	Cup, Paper	Bx	84.76	@ROUNDUP(+F340/2000)	+AA169*AB169
8540-00-276-7569	Napkin, Paper	Bx	34.06	@ROUNDUP(+F346/6000)	+AA170*AB170
8315-00-255-7662	Engineer Tape	Ro	9.5	+F168	+AA172*AB172
9140-00-273-2377	Diesel Fuel	Gl	0.7	+F326	+AA173*AB173
9150-00-189-6727	Lube Oil, 10wt	1-Qt Cn	1.27	+Q146	+AA174*AB174
9150-00-186-6668	Lube Oil, 10wt	5-Gl Cn	22.81	+Q147	+AA175*AB175
9150-00-191-2772	Lube Oil, 10wt	55-Gl Dr	195.4	+Q148	+AA177*AB177
9150-00-186-6681	Lube Oil, 30wt	1-Qt Cn	1.99	+Q151	+AA178*AB178
9150-00-188-9858	Lube Oil, 30wt	5-Gl Cn	19.11	+Q152	+AA179*AB179
9150-00-189-6729	Lube Oil, 30wt	Dr	172.75	+Q153	+AA180*AB180
9150-01-035-5392	Lube Oil, 90wt	1-Qt Cn	2.11	+Q156	+AA181*AB181
9150-01-035-5395	Lube Oil, 90wt	5-Gl Cn	25.01	+Q157	+AA183*AB183
9150-00-035-5393	Lube Oil, 90wt	55 Gl Dr	171.97	+Q158	+AA184*AB184
9150-00-190-0905	Grease, GAA	6.5-Lb Cn	5.4	+Q161	+AA185*AB185
9150-00-190-0907	Grease, GAA	35-LbCn	20.15	+Q162	+AA186*AB186
9150-00-053-6688	CLP	Gl	18.91	+Q164	+AA187*AB187
9150-00-054-6453	CLP	Pt	3.53	+Q165	+AA189*AB189
				Total	@SUM(AC148, AC189)





## APPENDIX C. CAX 8-93 TEMPLATES

The remaining BOM/ISR, intermediate level and lower level templates used in the CAX 8-93 case study are included in this appendix.

**200 LEVEL "PARTS"**

Part No: 201 Lot-for-Lot= 2  
 Part Name: PLATOON HEADQUARTERS LT= 1 week(s)

Exercise Support Requirements:		Backlog	Week 1	2	3	4	5	6	7	8	9	10	11	12	Future
Customer	ITEEP No.	Qty per Part No.	04-Nov	11-Nov	18-Nov	25-Nov	02-Dec	09-Dec	16-Dec	23-Dec	30-Dec	06-Jan	13-Jan	20-Jan	27-Jan
23d Mannes	M33018	1 per 101	0	0	0	0	0	0	0	2	0	0	0	0	ERR
<b>Total Requirements</b>			0	0	0	0	0	0	0	2	0	0	0	0	ERR
On Hand			0	0	0	0	0	0	0	-2	-2	-2	-2	-2	ERR
Planned Order Releases			0	0	0	0	0	0	2	0	0	0	0	0	ERR

REMARKS:

Part No: 202 Lot-for-Lot= 6  
 Part Name: ENGINEER SQUAD LT= 1 week(s)

Exercise Support Requirements:		Backlog	Week 1	2	3	4	5	6	7	8	9	10	11	12	Future
Customer	ITEEP No.	Qty per Part No.	04-Nov	11-Nov	18-Nov	25-Nov	02-Dec	09-Dec	16-Dec	23-Dec	30-Dec	06-Jan	13-Jan	20-Jan	27-Jan
23d Mannes	M33018	3 per 101	0	0	0	0	0	0	0	6	0	0	0	0	ERR
<b>Total Requirements</b>			0	0	0	0	0	0	0	6	0	0	0	0	ERR
On Hand			0	0	0	0	0	0	0	-6	-6	-6	-6	-6	ERR
Planned Order Releases			0	0	0	0	0	0	6	0	0	0	0	0	ERR

REMARKS:

Part No: 203 Lot-for-Lot= 1  
 Part Name: ENGR EQUIP/ MOTOR T SECTION LT= 1 week(s)

Exercise Support Requirements:		Backlog	Week 1	2	3	4	5	6	7	8	9	10	11	12	Future
Customer	ITEEP No.	Qty per Part No.	04-Nov	11-Nov	18-Nov	25-Nov	02-Dec	09-Dec	16-Dec	23-Dec	30-Dec	06-Jan	13-Jan	20-Jan	27-Jan
23d Mannes	M33018	0.5 per 101	0	0	0	0	0	0	0	1	0	0	0	0	ERR
<b>Total Requirements</b>			0	0	0	0	0	0	0	1	0	0	0	0	ERR
On Hand			0	0	0	0	0	0	0	-1	-1	-1	-1	-1	ERR
Planned Order Releases			0	0	0	0	0	0	1	0	0	0	0	0	ERR

REMARKS: ONE HE/M T SECTION WILL SUPPORT BOTH ENGINEER PLATOONS: I.E. .5 PER PART 101.

**300 LEVEL "PARTS"**

Part No: 301 Lot-for-Lot= 6  
 Part Name: ENGINEER OFFICER/SNCO LT= 1 week(s)

Exercise Support Requirements:		Backlog	Week 1	2	3	4	5	6	7	8	9	10	11	12	Future
Qty per	Part No.	04-Nov	11-Nov	18-Nov	25-Nov	02-Dec	09-Dec	16-Dec	23-Dec	30-Dec	06-Jan	13-Jan	20-Jan	27-Jan	
3	per 201	0	0	0	0	0	2	0	0	0	0	0	0	0	ERR
Total Requirements		0	0	0	0	0	2	0	0	0	0	0	0	0	ERR
On Hand		0	0	0	0	0	0	0	0	0	0	0	0	0	ERR
Planned Order Releases		0	0	0	0	0	0	0	0	0	0	0	0	0	ERR

REMARKS: ACTUALLY TWO PER 201, THE OTHER TWO ACCOUNT FOR THE COMPANY COMMANDER AND 1ST SGT.

Part No: 302 Lot-for-Lot= 10  
 Part Name: CAN, WATER LT= 0 week(s)

Exercise Support Requirements:		Backlog	Week 1	2	3	4	5	6	7	8	9	10	11	12	Future
Qty per	Part No.	04-Nov	11-Nov	18-Nov	25-Nov	02-Dec	09-Dec	16-Dec	23-Dec	30-Dec	06-Jan	13-Jan	20-Jan	27-Jan	
5	per 201	0	0	0	0	0	0	2	0	0	0	0	0	0	ERR
Total Requirements		0	0	0	0	0	0	2	0	0	0	0	0	0	ERR
On Hand		0	0	0	0	0	0	0	0	0	0	0	0	0	ERR
Planned Order Releases		0	0	0	0	0	0	0	0	0	0	0	0	0	ERR

REMARKS:

Part No: 303 Lot-for-Lot= 50  
 Part Name: COMBAT ENGINEER (1371) LT= 1 week(s)

Exercise Support Requirements:		Backlog	Week 1	2	3	4	5	6	7	8	9	10	11	12	Future
Qty per	Part No.	04-Nov	11-Nov	18-Nov	25-Nov	02-Dec	09-Dec	16-Dec	23-Dec	30-Dec	06-Jan	13-Jan	20-Jan	27-Jan	
8	per 202	0	0	0	0	0	0	2	0	0	0	0	0	0	ERR
Total Requirements		0	0	0	0	0	0	2	0	0	0	0	0	0	ERR
On Hand		0	0	0	0	0	0	0	0	0	0	0	0	0	ERR
Planned Order Releases		0	0	0	0	0	0	0	0	0	0	0	0	0	ERR

REMARKS: 8 MAN ENGINEER SQUADS DUE TO PERSONNEL SHORTAGE

Part No: 304 Lot-for-Lot= 2  
 Part Name: AN/PVS-4, NIGHT VISION SIGHT LT= 0 week(s)

Exercise Support Requirements:		Backlog	Week 1	2	3	4	5	6	7	8	9	10	11	12	Future
Qty per	Part No.	04-Nov	11-Nov	18-Nov	25-Nov	02-Dec	09-Dec	16-Dec	23-Dec	30-Dec	06-Jan	13-Jan	20-Jan	27-Jan	
1	per 201	0	0	0	0	0	0	2	0	0	0	0	0	0	ERR
Total Requirements		0	0	0	0	0	0	2	0	0	0	0	0	0	ERR
On Hand		0	0	0	0	0	0	0	0	0	0	0	0	0	ERR
Planned Order Releases		0	0	0	0	0	0	0	0	0	0	0	0	0	ERR

REMARKS:

Part No: 305 Lot-for-Lot= 4  
 Part Name: AN/PVS-5A NIGHT VISION GOGGLES LT= 0 week(s)

Exercise Support Requirements:		Backlog	Week 1	2	3	4	5	6	7	8	9	10	11	12	Future
Qty per	Part No.	04-Nov	11-Nov	18-Nov	25-Nov	02-Dec	09-Dec	16-Dec	23-Dec	30-Dec	06-Jan	13-Jan	20-Jan	27-Jan	
2	per 201	0	0	0	0	0	0	2	0	0	0	0	0	0	ERR
Total Requirements		0	0	0	0	0	0	2	0	0	0	0	0	0	ERR
On Hand		0	0	0	0	0	0	0	0	0	0	0	0	0	ERR
Planned Order Releases		0	0	0	0	0	0	0	0	0	0	0	0	0	ERR

REMARKS:

Part No: 306 Lot-for-Lot= 3  
 Part Name: RADIO OPERATOR (2531) LT= 1 week(s)

Exercise Support Requirements:		Backlog	Week 1	2	3	4	5	6	7	8	9	10	11	12	Future
Qty per	Part No.	04-Nov	11-Nov	18-Nov	25-Nov	02-Dec	09-Dec	16-Dec	23-Dec	30-Dec	06-Jan	13-Jan	20-Jan	27-Jan	
1.5	per 201	0	0	0	0	0	0	2	0	0	0	0	0	0	ERR
Total Requirements		0	0	0	0	0	0	2	0	0	0	0	0	0	ERR
On Hand		0	0	0	0	0	0	0	0	0	0	0	0	0	ERR
Planned Order Releases		0	0	0	0	0	0	0	0	0	0	0	0	0	ERR

REMARKS: ONE PER 201, FLT HDQTRS, .5 IS FOR THE COMPANY HDQTRS

Part No: 307 Lot-for-Lot= 6  
 Part Name: RADIO SET, PRC-77 LT= 1 week(s)

Exercise Support Requirements:		Backlog	Week 1	2	3	4	5	6	7	8	9	10	11	12	Future
Qty per	Part No		04-Nov	11-Nov	18-Nov	25-Nov	02-Dec	09-Dec	16-Dec	23-Dec	30-Dec	06-Jan	13-Jan	20-Jan	27-Jan
3	per 201	0	0	0	0	0	0	2	0	0	0	0	0	0	ERR
0	per 202	0	0	0	0	0	0	6	0	0	0	0	0	0	ERR
Total Requirements		0	0	0	0	0	0	6	0	0	0	0	0	0	ERR
On Hand		0	0	0	0	0	0	0	0	0	0	0	0	0	ERR
Planned Order Releases		0	0	0	0	0	0	-6	-6	-5	-6	-6	-5	ERR	ERR

REMARKS: ACTUALLY TWO PER 201, ONE COMPANY HDQTRS

Part No: 308 Lot-for-Lot= 0  
 Part Name: MACHINE GUN, 7.62MM, M60E3 LT= 0 week(s)

Exercise Support Requirements:		Backlog	Week 1	2	3	4	5	6	7	8	9	10	11	12	Future
Qty per	Part No		04-Nov	11-Nov	18-Nov	25-Nov	02-Dec	09-Dec	16-Dec	23-Dec	30-Dec	06-Jan	13-Jan	20-Jan	27-Jan
0	per 201	0	0	0	0	0	0	2	0	0	0	0	0	0	ERR
Total Requirements		0	0	0	0	0	0	2	0	0	0	0	0	0	ERR
On Hand		0	0	0	0	0	0	0	0	0	0	0	0	0	ERR
Planned Order Releases		0	0	0	0	0	0	0	0	0	0	0	0	0	ERR

REMARKS:

Part No: 309 Lot-for-Lot= 5  
 Part Name: BINOCULARS LT= 0 week(s)

Exercise Support Requirements:		Backlog	Week 1	2	3	4	5	6	7	8	9	10	11	12	Future
Qty per	Part No		04-Nov	11-Nov	18-Nov	25-Nov	02-Dec	09-Dec	16-Dec	23-Dec	30-Dec	06-Jan	13-Jan	20-Jan	27-Jan
2.5	per 201	0	0	0	0	0	0	2	0	0	0	0	0	0	ERR
Total Requirements		0	0	0	0	0	0	5	0	0	0	0	0	0	ERR
On Hand		2	2	2	2	2	2	2	-3	-3	-3	-3	-3	-3	ERR
Planned Order Releases		0	0	0	0	0	0	3	0	0	0	0	0	0	ERR

REMARKS: TWO PER 201, ONE PER COMPANY HDQTRS.

Part No: 310 Lot-for-Lot= 3  
 Part Name: TRUCK, UTILITY 1.75T, HMMWW LT= 0 week(s)

Exercise Support Requirements:		Backlog	Week 1	2	3	4	5	6	7	8	9	10	11	12	Future
Qty per	Part No		04-Nov	11-Nov	18-Nov	25-Nov	02-Dec	09-Dec	16-Dec	23-Dec	30-Dec	06-Jan	13-Jan	20-Jan	27-Jan
1.5	per 201	0	0	0	0	0	0	2	0	0	0	0	0	0	ERR
0	per 202	0	0	0	0	0	0	6	0	0	0	0	0	0	ERR
Total Requirements		0	0	0	0	0	0	3	0	0	0	0	0	0	ERR
On Hand		0	0	0	0	0	0	-3	-3	-3	-3	-3	-3	-3	ERR
Planned Order Releases		0	0	0	0	0	0	3	0	0	0	0	0	0	ERR

REMARKS: ONE PER 201, ONE PER COMPANY HDQTRS FOR THREE TOTAL.

Part No: 311 Lot-for-Lot= 1  
 Part Name: TOOL KIT, CARPENTER'S, ENGR PLT LT= 0 week(s)

Exercise Support Requirements:		Backlog	Week 1	2	3	4	5	6	7	8	9	10	11	12	Future
Qty per	Part No		04-Nov	11-Nov	18-Nov	25-Nov	02-Dec	09-Dec	16-Dec	23-Dec	30-Dec	06-Jan	13-Jan	20-Jan	27-Jan
0.5	per 201	0	0	0	0	0	0	2	0	0	0	0	0	0	ERR
Total Requirements		0	0	0	0	0	0	1	0	0	0	0	0	0	ERR
On Hand		1	1	1	1	1	1	0	0	0	0	0	0	0	ERR
Planned Order Releases		0	0	0	0	0	0	0	0	0	0	0	0	0	ERR

REMARKS: ONE PER COMPANY

Part No: 312 Lot-for-Lot= 1  
 Part Name: MINEFIELD MARKING KIT LT= 0 week(s)

Exercise Support Requirements:		Backlog	Week 1	2	3	4	5	6	7	8	9	10	11	12	Future
Qty per	Part No		04-Nov	11-Nov	18-Nov	25-Nov	02-Dec	09-Dec	16-Dec	23-Dec	30-Dec	06-Jan	13-Jan	20-Jan	27-Jan
0.5	per 201	0	0	0	0	0	0	2	0	0	0	0	0	0	ERR
Total Requirements		0	0	0	0	0	0	1	0	0	0	0	0	0	ERR
On Hand		0	0	0	0	0	0	-1	-1	-1	-1	-1	-1	-1	ERR
Planned Order Releases		0	0	0	0	0	0	1	0	0	0	0	0	0	ERR

REMARKS: ONE PER COMPANY

Part No: 313 Lot-for-Lot= 6  
 Part Name: DETECTING SET, MINE, MET., AF-108 LT= 0 week(s)

Exercise Support Requirements:		Backlog	Week 1	2	3	4	5	6	7	8	9	10	11	12	Future
Qty per	Part No.	04-Nov	11-Nov	18-Nov	25-Nov	02-Dec	09-Dec	16-Dec	23-Dec	30-Dec	06-Jan	13-Jan	20-Jan	27-Jan	
1	per 202	0	0	0	0	0	0	6	0	0	0	0	0	0	ERR
Total Requirements		0	0	0	0	0	0	6	0	0	0	0	0	0	ERR
On Hand		0	0	0	0	0	0	-6	-6	-6	-6	-6	-6	-6	ERR
Planned Order Releases		0	0	0	0	0	0	6	0	0	0	0	0	0	ERR

REMARKS:

Part No: 314 Lot-for-Lot= 0  
 Part Name: LAUNCHER, ASLT, ROCKET, SMAW LT= 0 week(s)

Exercise Support Requirements:		Backlog	Week 1	2	3	4	5	6	7	8	9	10	11	12	Future
Qty per	Part No.	04-Nov	11-Nov	18-Nov	25-Nov	02-Dec	09-Dec	16-Dec	23-Dec	30-Dec	06-Jan	13-Jan	20-Jan	27-Jan	
0	per 202	0	0	0	0	0	0	6	0	0	0	0	0	0	ERR
Total Requirements		0	0	0	0	0	0	6	0	0	0	0	0	0	ERR
On Hand		0	0	0	0	0	0	0	0	0	0	0	0	0	ERR
Planned Order Releases		0	0	0	0	0	0	6	0	0	0	0	0	0	ERR

REMARKS:

Part No: 315 Lot-for-Lot= 6  
 Part Name: MACHINE GUN, 5.56MM, SAW LT= 0 week(s)

Exercise Support Requirements:		Backlog	Week 1	2	3	4	5	6	7	8	9	10	11	12	Future
Qty per	Part No.	04-Nov	11-Nov	18-Nov	25-Nov	02-Dec	09-Dec	16-Dec	23-Dec	30-Dec	06-Jan	13-Jan	20-Jan	27-Jan	
1	per 202	0	0	0	0	0	0	6	0	0	0	0	0	0	ERR
Total Requirements		0	0	0	0	0	0	6	0	0	0	0	0	0	ERR
On Hand		0	0	0	0	0	0	-6	-6	-6	-6	-6	-6	-6	ERR
Planned Order Releases		0	0	0	0	0	0	6	0	0	0	0	0	0	ERR

REMARKS:

Part No: 316 Lot-for-Lot= 6  
 Part Name: TOOL KIT, PIONEER, ENGR SQUAD LT= 0 week(s)

Exercise Support Requirements:		Backlog	Week 1	2	3	4	5	6	7	8	9	10	11	12	Future
Qty per	Part No.	04-Nov	11-Nov	18-Nov	25-Nov	02-Dec	09-Dec	16-Dec	23-Dec	30-Dec	06-Jan	13-Jan	20-Jan	27-Jan	
1	per 202	0	0	0	0	0	0	6	0	0	0	0	0	0	ERR
Total Requirements		0	0	0	0	0	0	6	0	0	0	0	0	0	ERR
On Hand		0	0	0	0	0	0	-6	-6	-6	-6	-6	-6	-6	ERR
Planned Order Releases		0	0	0	0	0	0	6	0	0	0	0	0	0	ERR

REMARKS:

Part No: 317 Lot-for-Lot= 0  
 Part Name: SAW, CHAIN, ONE MAN PORTABLE LT= 0 week(s)

Exercise Support Requirements:		Backlog	Week 1	2	3	4	5	6	7	8	9	10	11	12	Future
Qty per	Part No.	04-Nov	11-Nov	18-Nov	25-Nov	02-Dec	09-Dec	16-Dec	23-Dec	30-Dec	06-Jan	13-Jan	20-Jan	27-Jan	
0	per 202	0	0	0	0	0	0	6	0	0	0	0	0	0	ERR
Total Requirements		0	0	0	0	0	0	6	0	0	0	0	0	0	ERR
On Hand		0	0	0	0	0	0	0	0	0	0	0	0	0	ERR
Planned Order Releases		0	0	0	0	0	0	6	0	0	0	0	0	0	ERR

REMARKS:

Part No: 318 Lot-for-Lot= 6  
 Part Name: DEMOLITION EQUIP, ENGR SQD LT= 0 week(s)

Exercise Support Requirements:		Backlog	Week 1	2	3	4	5	6	7	8	9	10	11	12	Future
Qty per	Part No.	04-Nov	11-Nov	18-Nov	25-Nov	02-Dec	09-Dec	16-Dec	23-Dec	30-Dec	06-Jan	13-Jan	20-Jan	27-Jan	
1	per 202	0	0	0	0	0	0	6	0	0	0	0	0	0	ERR
Total Requirements		0	0	0	0	0	0	6	0	0	0	0	0	0	ERR
On Hand		0	0	0	0	0	0	-6	-6	-6	-6	-6	-6	-6	ERR
Planned Order Releases		0	0	0	0	0	0	6	0	0	0	0	0	0	ERR

REMARKS:

Part No: 319 Lot-for-Lot= 6  
 Part Name: CAMOUFLAGE STICK LT= 2 week(s)

Qty per	Part No	Backlog	Week 1	2	3	4	5	6	7	8	9	10	11	12	Future
1	per 202	0	0	0	0	0	0	0	0	0	0	0	0	0	ERR
Total Requirements		0	0	0	0	0	0	0	0	0	0	0	0	0	ERR

Order Date	Qty	Due Date	04-Nov	11-Nov	18-Nov	25-Nov	02-Dec	09-Dec	16-Dec	23-Dec	30-Dec	06-Jan	13-Jan	20-Jan	27-Jan
02/21/95	1	10/27/95													
02/21/95	1	11/03/95		1											
Scheduled Receipts			1	0	0	0	0	0	0	0	0	0	0	0	0

On Hand	3	3	4	4	4	4	4	2	0	0	0	0	0	0	0
Planned Order Releases		0	0	0	0	2	0	0	0	0	0	0	0	0	ERR

REMARKS: O/O QUANTITIES UNDERCATED. CAN BE USED TO SUPPORT THIS EXERCISE  
 Class II Requirements to be submitted by 08/01/96

Part No: 320 Lot-for-Lot= 2  
 Part Name: ENGINEER EQUIPMENT MECHANIC LT= 1 week(s)

Qty per	Part No	Backlog	Week 1	2	3	4	5	6	7	8	9	10	11	12	Future
2	per 203	0	0	0	0	0	0	0	0	0	0	0	0	0	ERR
Total Requirements		0	0	0	0	0	0	0	0	0	0	0	0	0	ERR

On Hand	0	0	0	0	0	0	0	2	0	0	0	0	0	0	ERR
Planned Order Releases		0	0	0	0	0	0	-2	-2	-2	-2	-2	-2	-2	ERR

REMARKS:

Part No: 321 Lot-for-Lot= 1  
 Part Name: TRACTOR, RUBBER TIRED, TRAM LT= 1 week(s)

Qty per	Part No	Backlog	Week 1	2	3	4	5	6	7	8	9	10	11	12	Future
1	per 203	0	0	0	0	0	0	0	0	0	0	0	0	0	ERR
Total Requirements		0	0	0	0	0	0	0	0	0	0	0	0	0	ERR

On Hand	0	0	0	0	0	0	0	-1	-1	-1	-1	-1	-1	-1	ERR
Planned Order Releases		0	0	0	0	0	0	1	0	0	0	0	0	0	ERR

REMARKS:

Part No: 322 Lot-for-Lot= 2  
 Part Name: TRACTOR AWD W/ ATTACH, SEE LT= 1 week(s)

Qty per	Part No	Backlog	Week 1	2	3	4	5	6	7	8	9	10	11	12	Future
2	per 203	0	0	0	0	0	0	0	0	0	0	0	0	0	ERR
Total Requirements		0	0	0	0	0	0	0	0	0	0	0	0	0	ERR

On Hand	0	0	0	0	0	0	0	-2	-2	-2	-2	-2	-2	-2	ERR
Planned Order Releases		0	0	0	0	0	0	2	0	0	0	0	0	0	ERR

REMARKS:

Part No: 323 Lot-for-Lot= 1  
 Part Name: TRACTOR, FULL TRACKED, D7G LT= 1 week(s)

Qty per	Part No	Backlog	Week 1	2	3	4	5	6	7	8	9	10	11	12	Future
1	per 203	0	0	0	0	0	0	0	0	0	0	0	0	0	ERR
Total Requirements		0	0	0	0	0	0	0	0	0	0	0	0	0	ERR

On Hand	0	0	0	0	0	0	0	-1	-1	-1	-1	-1	-1	-1	ERR
Planned Order Releases		0	0	0	0	0	0	1	0	0	0	0	0	0	ERR

REMARKS:

Part No: 324 Lot-for-Lot= 2  
 Part Name: LINE CHARGE LAUNCH KIT, TRLR MT LT= 1 week(s)

Qty per	Part No	Backlog	Week 1	2	3	4	5	6	7	8	9	10	11	12	Future
2	per 203	0	0	0	0	0	0	0	0	0	0	0	0	0	ERR
Total Requirements		0	0	0	0	0	0	0	0	0	0	0	0	0	ERR

On Hand	0	0	0	0	0	0	0	-2	-2	-2	-2	-2	-2	-2	ERR
Planned Order Releases		0	0	0	0	0	0	2	0	0	0	0	0	0	ERR

REMARKS:

Part No: 325 Lot-for-Lot= 0  
 Part Name: TRACTOR, FULL TRACKED, 1150E LT= 1 week(s)

Exercise Support Requirements:		Backlog	Week 1	2	3	4	5	6	7	8	9	10	11	12	Future
Qty per	Part No.	04-Nov	11-Nov	18-Nov	25-Nov	02-Dec	09-Dec	16-Dec	23-Dec	30-Dec	06-Jan	13-Jan	20-Jan	27-Jan	
0	per 203	0	0	0	0	0	0	1	0	0	0	0	0	0	ERR
Total Requirements		0	0	0	0	0	0	1	0	0	0	0	0	0	ERR
On Hand		0	0	0	0	0	0	0	0	0	0	0	0	0	ERR
Planned Order Releases		0	0	0	0	0	0	0	0	0	0	0	0	0	ERR

REMARKS:

Part No: 326 Lot-for-Lot= 2  
 Part Name: MOTOR TRANSPORT MECHANIC LT= 1 week(s)

Exercise Support Requirements:		Backlog	Week 1	2	3	4	5	6	7	8	9	10	11	12	Future
Qty per	Part No.	04-Nov	11-Nov	18-Nov	25-Nov	02-Dec	09-Dec	16-Dec	23-Dec	30-Dec	06-Jan	13-Jan	20-Jan	27-Jan	
2	per 203	0	0	0	0	0	0	1	0	0	0	0	0	0	ERR
Total Requirements		0	0	0	0	0	0	2	0	0	0	0	0	0	ERR
On Hand		0	0	0	0	0	0	-2	-2	-2	-2	-2	-2	-2	ERR
Planned Order Releases		0	0	0	0	0	2	0	0	0	0	0	0	0	ERR

REMARKS:

Part No: 327 Lot-for-Lot= 1  
 Part Name: LOGISTICS VEHICLE SYSTEM, (LVS) LT= 1 week(s)

Exercise Support Requirements:		Backlog	Week 1	2	3	4	5	6	7	8	9	10	11	12	Future
Qty per	Part No.	04-Nov	11-Nov	18-Nov	25-Nov	02-Dec	09-Dec	16-Dec	23-Dec	30-Dec	06-Jan	13-Jan	20-Jan	27-Jan	
1	per 203	0	0	0	0	0	0	1	0	0	0	0	0	0	ERR
Total Requirements		0	0	0	0	0	0	1	0	0	0	0	0	0	ERR
On Hand		0	0	0	0	0	0	-1	-1	-1	-1	-1	-1	-1	ERR
Planned Order Releases		0	0	0	0	0	1	0	0	0	0	0	0	0	ERR

REMARKS:

Part No: 328 Lot-for-Lot= 2  
 Part Name: TRUCK CARGO, 5T, M-923 LT= 1 week(s)

Exercise Support Requirements:		Backlog	Week 1	2	3	4	5	6	7	8	9	10	11	12	Future
Qty per	Part No.	04-Nov	11-Nov	18-Nov	25-Nov	02-Dec	09-Dec	16-Dec	23-Dec	30-Dec	06-Jan	13-Jan	20-Jan	27-Jan	
2	per 203	0	0	0	0	0	0	1	0	0	0	0	0	0	ERR
Total Requirements		0	0	0	0	0	0	2	0	0	0	0	0	0	ERR
On Hand		0	0	0	0	0	0	-2	-2	-2	-2	-2	-2	-2	ERR
Planned Order Releases		0	0	0	0	0	2	0	0	0	0	0	0	0	ERR

REMARKS:

Part No: 329 Lot-for-Lot= 1  
 Part Name: TRAILER, CARGO, 1.5T, M-105 LT= 1 week(s)

Exercise Support Requirements:		Backlog	Week 1	2	3	4	5	6	7	8	9	10	11	12	Future
Qty per	Part No.	04-Nov	11-Nov	18-Nov	25-Nov	02-Dec	09-Dec	16-Dec	23-Dec	30-Dec	06-Jan	13-Jan	20-Jan	27-Jan	
1	per 203	0	0	0	0	0	0	1	0	0	0	0	0	0	ERR
Total Requirements		0	0	0	0	0	0	1	0	0	0	0	0	0	ERR
On Hand		0	0	0	0	0	0	-1	-1	-1	-1	-1	-1	-1	ERR
Planned Order Releases		0	0	0	0	0	1	0	0	0	0	0	0	0	ERR

REMARKS:

Part No: 330 Lot-for-Lot= 1  
 Part Name: TRUCK, DUMP, 5T, M929 LT= 1 week(s)

Exercise Support Requirements:		Backlog	Week 1	2	3	4	5	6	7	8	9	10	11	12	Future
Qty per	Part No.	04-Nov	11-Nov	18-Nov	25-Nov	02-Dec	09-Dec	16-Dec	23-Dec	30-Dec	06-Jan	13-Jan	20-Jan	27-Jan	
1	per 203	0	0	0	0	0	0	1	0	0	0	0	0	0	ERR
Total Requirements		0	0	0	0	0	0	1	0	0	0	0	0	0	ERR
On Hand		0	0	0	0	0	0	-1	-1	-1	-1	-1	-1	-1	ERR
Planned Order Releases		0	0	0	0	0	1	0	0	0	0	0	0	0	ERR

REMARKS:



400 LEVEL "PARTS"

Part No: 401 Lot-for-Lot= 6  
 Part Name: PISTOL, 9MM, SEMIAUTOMATIC, M9 LT= 0 week(s)

City per	Part No	Backlog	Week 1	2	3	4	5	6	7	8	9	10	11	12	Future
0.5	per 301	0	02-Dec	09-Dec	16-Dec	23-Dec	30-Dec	06-Jan	13-Jan	20-Jan	27-Jan	03-Feb	10-Feb	17-Feb	24-Feb
1		0	6	0	0	0	0	0	0	0	0	0	0	0	ERR
Total Requirements		0	6	0	0	0	0	0	0	0	0	0	0	0	ERR
On Hand		0	0	-6	-6	-6	-6	-6	-6	-6	-6	-6	-6	-6	ERR
Planned Order Releases		0	6	0	0	0	0	0	0	0	0	0	0	0	ERR

REMARKS:

Part No: 402 Lot-for-Lot= 9  
 Part Name: COMPASS LT= 0 week(s)

City per	Part No	Backlog	Week 1	2	3	4	5	6	7	8	9	10	11	12	Future
0.5	per 201	0	02-Dec	09-Dec	16-Dec	23-Dec	30-Dec	06-Jan	13-Jan	20-Jan	27-Jan	03-Feb	10-Feb	17-Feb	24-Feb
1	per 202	0	0	6	0	0	0	0	0	0	0	0	0	0	ERR
Total Requirements		0	0	6	0	0	0	0	0	0	0	0	0	0	ERR
On Hand		5	5	2	-4	-4	-4	-4	-4	-4	-4	-4	-4	-4	ERR
Planned Order Releases		0	0	6	0	0	0	0	0	0	0	0	0	0	ERR

REMARKS: ONE PER EVERY TWO OFF/SNCO, ONE PER SQUAD

Part No: 403 Lot-for-Lot= 18  
 Part Name: BATTERY, BA-5567 LT= 3 week(s)

City per	Part No	Backlog	Week 1	2	3	4	5	6	7	8	9	10	11	12	Future
2	per 304	0	02-Dec	09-Dec	16-Dec	23-Dec	30-Dec	06-Jan	13-Jan	20-Jan	27-Jan	03-Feb	10-Feb	17-Feb	24-Feb
3	per 305	0	0	0	4	0	0	0	0	0	0	0	0	0	ERR
Total Requirements		0	0	0	4	0	0	0	0	0	0	0	0	0	ERR

Order Date	Qty	Due Date	02-Dec	09-Dec	16-Dec	23-Dec	30-Dec	06-Jan	13-Jan	20-Jan	27-Jan	03-Feb	10-Feb	17-Feb	24-Feb
09/09/96	1	11/05/96													
Scheduled Receipts			0	0	0	0	0	0	0	0	0	0	0	0	0

REMARKS: QTY QUANTITIES UNDEDICATED, CAN BE USED TO SUPPORT THIS EXERCISE  
 Class II Requirements to be submitted by 06/01/96

Part No: 404 Lot-for-Lot= 24  
 Part Name: BATTERY, BA-5598 LT= 3 week(s)

City per	Part No	Backlog	Week 1	2	3	4	5	6	7	8	9	10	11	12	Future
4	per 307	0	02-Dec	09-Dec	16-Dec	23-Dec	30-Dec	06-Jan	13-Jan	20-Jan	27-Jan	03-Feb	10-Feb	17-Feb	24-Feb
Total Requirements		0	24	0	0	0	0	0	0	0	0	0	0	0	ERR

Order Date	Qty	Due Date	02-Dec	09-Dec	16-Dec	23-Dec	30-Dec	06-Jan	13-Jan	20-Jan	27-Jan	03-Feb	10-Feb	17-Feb	24-Feb
09/09/96	1	11/05/96													
Scheduled Receipts			0	0	0	0	0	0	0	0	0	0	0	0	0

REMARKS: QTY QUANTITIES UNDEDICATED, CAN BE USED TO SUPPORT THIS EXERCISE  
 Class II Requirements to be submitted by 06/01/96

Part No: 405 Lot-for-Lot= 0  
 Part Name: TRIPOD, MACHINEGUN, 7.62MM LT= 0 week(s)

City per	Part No	Backlog	Week 1	2	3	4	5	6	7	8	9	10	11	12	Future
1	per 308	0	02-Dec	09-Dec	16-Dec	23-Dec	30-Dec	06-Jan	13-Jan	20-Jan	27-Jan	03-Feb	10-Feb	17-Feb	24-Feb
Total Requirements		0	0	0	0	0	0	0	0	0	0	0	0	0	ERR
On Hand		0	0	0	0	0	0	0	0	0	0	0	0	0	ERR
Planned Order Releases		0	0	0	0	0	0	0	0	0	0	0	0	0	ERR

REMARKS:

Part No: 406 Lot-for-Lot= 4  
 Part Name: CYALUME LIGHTSTICK (YELLOW) LT= 1 week(s)

City per	Part No	Backlog	Week 1	2	3	4	5	6	7	8	9	10	11	12	Future
4	per 312	0	02-Dec	09-Dec	16-Dec	23-Dec	30-Dec	06-Jan	13-Jan	20-Jan	27-Jan	03-Feb	10-Feb	17-Feb	24-Feb
Total Requirements		0	0	4	0	0	0	0	0	0	0	0	0	0	ERR

Order Date	Qty	Due Date	02-Dec	09-Dec	16-Dec	23-Dec	30-Dec	06-Jan	13-Jan	20-Jan	27-Jan	03-Feb	10-Feb	17-Feb	24-Feb
09/09/96	1	11/05/96													
Scheduled Receipts			0	0	0	0	0	0	0	0	0	0	0	0	0

REMARKS: QTY QUANTITIES UNDEDICATED, CAN BE USED TO SUPPORT THIS EXERCISE  
 Class II Requirements to be submitted by 06/01/96

Part No: 407 Lot-for-Lot= 4  
 Part Name: CYALUME LIGHTSTICK (RED) LT= 1 week(s)

Exercise Support Requirements:		Backlog	Week 1	2	3	4	5	6	7	8	9	10	11	12	Future
Qty per	Part No.	02-Dec	09-Dec	16-Dec	23-Dec	30-Dec	06-Jan	13-Jan	20-Jan	27-Jan	03-Feb	10-Feb	17-Feb	24-Feb	
4	per 312	0	0	1	0	0	0	0	0	0	0	0	0	0	ERR
Total Requirements:		0	0	1	0	0	0	0	0	0	0	0	0	0	ERR

Outstanding Orders:		Order Date	Qty	Due Date	02-Dec	09-Dec	16-Dec	23-Dec	30-Dec	06-Jan	13-Jan	20-Jan	27-Jan	03-Feb	10-Feb	17-Feb	24-Feb
06/17/96	1	10/22/96															
09/09/96	0	11/05/96															
Scheduled Receipts:					0	0	0	0	0	0	0	0	0	0	0	0	0
On Hand Quantity:			2	2	2	2	0	0	0	0	0	0	0	0	0	0	ERR
Planned Order Releases:					0	1	0	0	0	0	0	0	0	0	0	0	ERR

REMARKS: 0/0 QUANTITIES UNDECATAG, CAN BE USED TO SUPPORT THIS EXERCISE  
 Class II Requirements to be submitted by 08/01/96

Part No: 408 Lot-for-Lot= 4  
 Part Name: CYALUME LIGHTSTICK (BLUE) LT= 1 week(s)

Exercise Support Requirements:		Backlog	Week 1	2	3	4	5	6	7	8	9	10	11	12	Future
Qty per	Part No.	02-Dec	09-Dec	16-Dec	23-Dec	30-Dec	06-Jan	13-Jan	20-Jan	27-Jan	03-Feb	10-Feb	17-Feb	24-Feb	
4	per 312	0	0	1	0	0	0	0	0	0	0	0	0	0	ERR
Total Requirements:		0	0	1	0	0	0	0	0	0	0	0	0	0	ERR

Outstanding Orders:		Order Date	Qty	Due Date	02-Dec	09-Dec	16-Dec	23-Dec	30-Dec	06-Jan	13-Jan	20-Jan	27-Jan	03-Feb	10-Feb	17-Feb	24-Feb
06/17/96	3	10/22/96															
09/09/96	0	11/05/96															
Scheduled Receipts:					0	0	0	0	0	0	0	0	0	0	0	0	0
On Hand Quantity:			3	3	3	1	0	0	0	0	0	0	0	0	0	0	ERR
Planned Order Releases:					0	1	0	0	0	0	0	0	0	0	0	0	ERR

REMARKS: 0/0 QUANTITIES UNDECATAG, CAN BE USED TO SUPPORT THIS EXERCISE  
 Class II Requirements to be submitted by 08/01/96

Part No: 409 Lot-for-Lot= 36  
 Part Name: BATTERY, BA-3030 LT= 1 week(s)

Exercise Support Requirements:		Backlog	Week 1	2	3	4	5	6	7	8	9	10	11	12	Future
Qty per	Part No.	02-Dec	09-Dec	16-Dec	23-Dec	30-Dec	06-Jan	13-Jan	20-Jan	27-Jan	03-Feb	10-Feb	17-Feb	24-Feb	
6	per 313	0	0	6	0	0	0	0	0	0	0	0	0	0	ERR
Total Requirements:		0	0	6	0	0	0	0	0	0	0	0	0	0	ERR

Outstanding Orders:		Order Date	Qty	Due Date	02-Dec	09-Dec	16-Dec	23-Dec	30-Dec	06-Jan	13-Jan	20-Jan	27-Jan	03-Feb	10-Feb	17-Feb	24-Feb
06/17/96	5	10/22/96															
09/09/96	20	11/05/96															
Scheduled Receipts:					0	0	0	0	0	0	0	0	0	0	0	0	0
On Hand Quantity:			0	0	0	36	0	0	0	0	0	0	0	0	0	0	ERR
Planned Order Releases:					0	1	0	0	0	0	0	0	0	0	0	0	ERR

REMARKS: 0/0 QUANTITIES UNDECATAG, CAN BE USED TO SUPPORT THIS EXERCISE  
 Class II Requirements to be submitted by 08/01/96

Part No: 410 Lot-for-Lot= 6  
 Part Name: ENGINEER TAPE LT= 1 week(s)

Exercise Support Requirements:		Backlog	Week 1	2	3	4	5	6	7	8	9	10	11	12	Future
Qty per	Part No.	02-Dec	09-Dec	16-Dec	23-Dec	30-Dec	06-Jan	13-Jan	20-Jan	27-Jan	03-Feb	10-Feb	17-Feb	24-Feb	
6	per 316	0	0	6	0	0	0	0	0	0	0	0	0	0	ERR
Total Requirements:		0	0	6	0	0	0	0	0	0	0	0	0	0	ERR

Outstanding Orders:		Order Date	Qty	Due Date	02-Dec	09-Dec	16-Dec	23-Dec	30-Dec	06-Jan	13-Jan	20-Jan	27-Jan	03-Feb	10-Feb	17-Feb	24-Feb
06/17/96	0	10/22/96															
09/09/96	2	11/25/96															
Scheduled Receipts:					0	0	0	0	0	0	0	0	0	0	0	0	0
On Hand Quantity:			2	2	2	4	0	0	0	0	0	0	0	0	0	0	ERR
Planned Order Releases:					0	2	0	0	0	0	0	0	0	0	0	0	ERR

REMARKS: 0/0 QUANTITIES UNDECATAG, CAN BE USED TO SUPPORT THIS EXERCISE  
 Class II Requirements to be submitted by 08/01/96

Part No: 411 Lot-for-Lot= 0  
 Part Name: MOGAS LT= 0 week(s)

Exercise Support Requirements:		Backlog	Week 1	2	3	4	5	6	7	8	9	10	11	12	Future
Qty per	Part No.	02-Dec	09-Dec	16-Dec	23-Dec	30-Dec	06-Jan	13-Jan	20-Jan	27-Jan	03-Feb	10-Feb	17-Feb	24-Feb	
0	per 317	0	0	0	0	0	0	0	0	0	0	0	0	0	ERR
Total Requirements:		0	0	0	0	0	0	0	0	0	0	0	0	0	ERR

Outstanding Orders:		Order Date	Qty	Due Date	02-Dec	09-Dec	16-Dec	23-Dec	30-Dec	06-Jan	13-Jan	20-Jan	27-Jan	03-Feb	10-Feb	17-Feb	24-Feb
06/17/96	0	10/22/96															
09/09/96	2	11/05/96															
Scheduled Receipts:					0	0	0	0	0	0	0	0	0	0	0	0	0
On Hand Quantity:			0	0	0	0	0	0	0	0	0	0	0	0	0	0	ERR
Planned Order Releases:					0	0	0	0	0	0	0	0	0	0	0	0	ERR

REMARKS: Class III Requirements to be submitted by 08/01/96

Part No: 412 Lot-for-Lot= 12  
 Part Name: ELECTRICAL TAPE LT= 1 week(s)

Exercise Support Requirements:		Backlog	Week 1	2	3	4	5	6	7	8	9	10	11	12	Future
Qty per	Part No.	02-Dec	09-Dec	16-Dec	23-Dec	30-Dec	06-Jan	13-Jan	20-Jan	27-Jan	03-Feb	10-Feb	17-Feb	24-Feb	
2	per 318	0	0	2	0	0	0	0	0	0	0	0	0	0	ERR
Total Requirements:		0	0	2	0	0	0	0	0	0	0	0	0	0	ERR

Outstanding Orders:		Order Date	Qty	Due Date	02-Dec	09-Dec	16-Dec	23-Dec	30-Dec	06-Jan	13-Jan	20-Jan	27-Jan	03-Feb	10-Feb	17-Feb	24-Feb
06/17/96	5	10/22/96															
09/09/96	2	11/05/96															
Scheduled Receipts:					0	0	0	0	0	0	0	0	0	0	0	0	0
On Hand Quantity:			7	7	7	5	0	0	0	0	0	0	0	0	0	0	ERR
Planned Order Releases:					0	1	0	0	0	0	0	0	0	0	0	0	ERR

REMARKS: 0/0 QUANTITIES UNDECATAG, CAN BE USED TO SUPPORT THIS EXERCISE  
 Class II Requirements to be submitted by 08/01/96

Part No: 413 Lot-for-Lot= 150  
 Part Name: DETONATING CORD CONNECTORS LT= 4 week(s)

Exercise Support Requirements:		Backlog	Week 1	2	3	4	5	6	7	8	9	10	11	12	Future
Qty per	Part No	02-Dec	09-Dec	16-Dec	23-Dec	30-Dec	06-Jan	13-Jan	20-Jan	27-Jan	03-Feb	10-Feb	17-Feb	24-Feb	
25	per 318	0	0	0	0	0	0	0	0	0	0	0	0	0	ERR
Total Requirements		0	0	150	0	0	0	0	0	0	0	0	0	0	ERR

Order Date		Qty	Due Date	02-Dec	09-Dec	16-Dec	23-Dec	30-Dec	06-Jan	13-Jan	20-Jan	27-Jan	03-Feb	10-Feb	17-Feb	24-Feb
08/31/96	5	10/22/96														
09/09/96	20	11/05/96														
Scheduled Receipts				0	0	0	0	0	0	0	0	0	0	0	0	0

On Hand Quantity:		75	75	75	75	0	0	0	0	0	0	0	0	0	ERR
Planned Order Releases:		0	0	0	0	0	0	0	0	0	0	0	0	0	ERR

REMARKS: QTY QUANTITIES UNDEDICATED, CAN BE USED TO SUPPORT THIS EXERCISE  
 Class II Requirements to be submitted by 06/01/96

Part No: 414 Lot-for-Lot= 2  
 Part Name: TOOL KIT, GENERAL MECHANICS LT= 0 week(s)

Exercise Support Requirements:		Backlog	Week 1	2	3	4	5	6	7	8	9	10	11	12	Future
Qty per	Part No	02-Dec	09-Dec	16-Dec	23-Dec	30-Dec	06-Jan	13-Jan	20-Jan	27-Jan	03-Feb	10-Feb	17-Feb	24-Feb	
05	per 320	0	2	0	0	0	0	0	0	0	0	0	0	0	ERR
05	per 326	0	2	0	0	0	0	0	0	0	0	0	0	0	ERR
Total Requirements		0	2	0	0	0	0	0	0	0	0	0	0	0	ERR

On Hand		0	0	-2	-2	-2	-2	-2	-2	-2	-2	-2	-2	-2	ERR
Planned Order Releases		0	0	2	0	0	0	0	0	0	0	0	0	0	ERR

REMARKS: ONE KIT PER EVERY TWO MECHANICS

Part No: 415 Lot-for-Lot= 1  
 Part Name: BUCKET, SCOOP, TRAM LT= 0 week(s)

Exercise Support Requirements:		Backlog	Week 1	2	3	4	5	6	7	8	9	10	11	12	Future
Qty per	Part No	02-Dec	09-Dec	16-Dec	23-Dec	30-Dec	06-Jan	13-Jan	20-Jan	27-Jan	03-Feb	10-Feb	17-Feb	24-Feb	
1	per 321	0	1	0	0	0	0	0	0	0	0	0	0	0	ERR
Total Requirements		0	1	0	0	0	0	0	0	0	0	0	0	0	ERR

On Hand		0	0	-1	-1	-1	-1	-1	-1	-1	-1	-1	-1	-1	ERR
Planned Order Releases		0	0	1	0	0	0	0	0	0	0	0	0	0	ERR

REMARKS:

Part No: 416 Lot-for-Lot= 1  
 Part Name: FORKLIFT, ATTACHMENT, TRAM LT= 0 week(s)

Exercise Support Requirements:		Backlog	Week 1	2	3	4	5	6	7	8	9	10	11	12	Future
Qty per	Part No	02-Dec	09-Dec	16-Dec	23-Dec	30-Dec	06-Jan	13-Jan	20-Jan	27-Jan	03-Feb	10-Feb	17-Feb	24-Feb	
1	per 321	0	1	0	0	0	0	0	0	0	0	0	0	0	ERR
Total Requirements		0	1	0	0	0	0	0	0	0	0	0	0	0	ERR

On Hand		0	0	-1	-1	-1	-1	-1	-1	-1	-1	-1	-1	-1	ERR
Planned Order Releases		0	0	1	0	0	0	0	0	0	0	0	0	0	ERR

REMARKS:

Part No: 417 Lot-for-Lot= 4  
 Part Name: ENGINEER EQUIPMENT OPERATOR LT= 0 week(s)

Exercise Support Requirements:		Backlog	Week 1	2	3	4	5	6	7	8	9	10	11	12	Future
Qty per	Part No	02-Dec	09-Dec	16-Dec	23-Dec	30-Dec	06-Jan	13-Jan	20-Jan	27-Jan	03-Feb	10-Feb	17-Feb	24-Feb	
1	per 321	0	1	0	0	0	0	0	0	0	0	0	0	0	ERR
1	per 322	0	2	0	0	0	0	0	0	0	0	0	0	0	ERR
1	per 323	0	1	0	0	0	0	0	0	0	0	0	0	0	ERR
1	per 325	0	0	0	0	0	0	0	0	0	0	0	0	0	ERR
Total Requirements		0	4	0	0	0	0	0	0	0	0	0	0	0	ERR

On Hand		0	0	-4	-4	-4	-4	-4	-4	-4	-4	-4	-4	-4	ERR
Planned Order Releases		0	0	4	0	0	0	0	0	0	0	0	0	0	ERR

REMARKS:

Part No: 418 Lot-for-Lot= 1  
 Part Name: POWER UNIT, FRONT, MK48 LT= 0 week(s)

Exercise Support Requirements:		Backlog	Week 1	2	3	4	5	6	7	8	9	10	11	12	Future
Qty per	Part No	02-Dec	09-Dec	16-Dec	23-Dec	30-Dec	06-Jan	13-Jan	20-Jan	27-Jan	03-Feb	10-Feb	17-Feb	24-Feb	
1	per 327	0	1	0	0	0	0	0	0	0	0	0	0	0	ERR
Total Requirements		0	1	0	0	0	0	0	0	0	0	0	0	0	ERR

On Hand		0	0	-1	-1	-1	-1	-1	-1	-1	-1	-1	-1	-1	ERR
Planned Order Releases		0	0	1	0	0	0	0	0	0	0	0	0	0	ERR

REMARKS:

Part No: 419 Lot-for-Lot= 1  
 Part Name: TRAILER, SEMI, 5TH WHEEL, MK16 LT= 0 week(s)

Exercise Support Requirements:		Backlog	Week 1	2	3	4	5	6	7	8	9	10	11	12	Future	
Qty per	Part No.		02-Dec	09-Dec	16-Dec	23-Dec	30-Dec	06-Jan	13-Jan	20-Jan	27-Jan	03-Feb	10-Feb	17-Feb	24-Feb	
1	per 327	0	1	0	0	0	0	0	0	0	0	0	0	ERR	ERR	ERR
Total Requirements		0	1	0	0	0	0	0	0	0	0	0	0	ERR	ERR	ERR
On Hand		0	0	-1	-1	-1	-1	-1	-1	-1	-1	-1	-1	ERR	ERR	ERR
Planned Order Releases		0	1	0	0	0	0	0	0	0	0	0	0	ERR	ERR	ERR

REMARKS:

Part No: 420 Lot-for-Lot= 1  
 Part Name: TRAILER, SEMI, LOWBED, M870 LT= 0 week(s)

Exercise Support Requirements:		Backlog	Week 1	2	3	4	5	6	7	8	9	10	11	12	Future	
Qty per	Part No.		02-Dec	09-Dec	16-Dec	23-Dec	30-Dec	06-Jan	13-Jan	20-Jan	27-Jan	03-Feb	10-Feb	17-Feb	24-Feb	
1	per 327	0	1	0	0	0	0	0	0	0	0	0	0	ERR	ERR	ERR
Total Requirements		0	1	0	0	0	0	0	0	0	0	0	0	ERR	ERR	ERR
On Hand		0	0	-1	-1	-1	-1	-1	-1	-1	-1	-1	-1	ERR	ERR	ERR
Planned Order Releases		0	1	0	0	0	0	0	0	0	0	0	0	ERR	ERR	ERR

REMARKS:

Part No: 421 Lot-for-Lot= 1  
 Part Name: HEAVY MOTOR VEHICLE OPERATOR LT= 0 week(s)

Exercise Support Requirements:		Backlog	Week 1	2	3	4	5	6	7	8	9	10	11	12	Future	
Qty per	Part No.		02-Dec	09-Dec	16-Dec	23-Dec	30-Dec	06-Jan	13-Jan	20-Jan	27-Jan	03-Feb	10-Feb	17-Feb	24-Feb	
1	per 327	0	1	0	0	0	0	0	0	0	0	0	0	ERR	ERR	ERR
Total Requirements		0	1	0	0	0	0	0	0	0	0	0	0	ERR	ERR	ERR
On Hand		0	0	-1	-1	-1	-1	-1	-1	-1	-1	-1	-1	ERR	ERR	ERR
Planned Order Releases		0	1	0	0	0	0	0	0	0	0	0	0	ERR	ERR	ERR

REMARKS:

Part No: 422 Lot-for-Lot= 3  
 Part Name: MOTOR VEHICLE OPERATOR (3531) LT= 0 week(s)

Exercise Support Requirements:		Backlog	Week 1	2	3	4	5	6	7	8	9	10	11	12	Future	
Qty per	Part No.		02-Dec	09-Dec	16-Dec	23-Dec	30-Dec	06-Jan	13-Jan	20-Jan	27-Jan	03-Feb	10-Feb	17-Feb	24-Feb	
1	per 328	0	1	0	0	0	0	0	0	0	0	0	0	ERR	ERR	ERR
1	per 330	0	1	0	0	0	0	0	0	0	0	0	0	ERR	ERR	ERR
Total Requirements		0	2	0	0	0	0	0	0	0	0	0	0	ERR	ERR	ERR
On Hand		0	0	-2	-2	-2	-2	-2	-2	-2	-2	-2	-2	ERR	ERR	ERR
Planned Order Releases		0	3	0	0	0	0	0	0	0	0	0	0	ERR	ERR	ERR

REMARKS:

500 LEVEL "PARTS"

Part No: 501 Lot-for-Lot= 12  
 Part Name: PATCHES, 7.62MM LT= 3 week(s)

Exercise Support Requirements:		Backlog	Week 1	2	3	4	5	6	7	8	9	10	11	12	Future
Qty per	Part No.	02-Dec	09-Dec	16-Dec	23-Dec	30-Dec	06-Jan	13-Jan	20-Jan	27-Jan	03-Feb	10-Feb	17-Feb	24-Feb	
1	per 308	0	0	0	0	0	0	0	0	0	0	0	0	0	ERR
1	per 401	0	6	0	0	0	0	0	0	0	0	0	0	0	ERR
Total Requirements		0	6	0	0	0	0	0	0	0	0	0	0	0	ERR

Outstanding Orders:		02-Dec	09-Dec	16-Dec	23-Dec	30-Dec	06-Jan	13-Jan	20-Jan	27-Jan	03-Feb	10-Feb	17-Feb	24-Feb
Order Date:	Qty													
08/31/96	0													
09/09/96	0													
Scheduled Receipts		0	0	0	0	0	0	0	0	0	0	0	0	0

On Hand Quantity:	1	1	-5	0	0	0	0	0	0	0	0	0	0	0
Planned Order Releases:	0	0	0	0	0	0	0	0	0	ERR	ERR	ERR	ERR	ERR

REMARKS: O/O QUANTITIES UNDEDICATED, CAN BE USED TO SUPPORT THIS EXERCISE  
 Class II Requirements to be submitted by 08/01/96

Part No: 502 Lot-for-Lot= 1562  
 Part Name: MEAL, READY TO EAT LT= 4 week(s)

Exercise Support Requirements:		Backlog	Week 1	2	3	4	5	6	7	8	9	10	11	12	Future
Qty per	Part No.	02-Dec	09-Dec	16-Dec	23-Dec	30-Dec	06-Jan	13-Jan	20-Jan	27-Jan	03-Feb	10-Feb	17-Feb	24-Feb	
22	per 301	0	6	0	0	0	0	0	0	0	0	0	0	0	ERR
22	per 303	0	50	0	0	0	0	0	0	0	0	0	0	0	ERR
22	per 306	0	3	0	0	0	0	0	0	0	0	0	0	0	ERR
22	per 320	0	2	0	0	0	0	0	0	0	0	0	0	0	ERR
22	per 326	0	2	0	0	0	0	0	0	0	0	0	0	0	ERR
22	per 417	0	4	0	0	0	0	0	0	0	0	0	0	0	ERR
22	per 421	0	1	0	0	0	0	0	0	0	0	0	0	0	ERR
22	per 422	0	3	0	0	0	0	0	0	0	0	0	0	0	ERR
Total Requirements		0	1562	0	0	0	0	0	0	0	0	0	0	0	ERR

Outstanding Orders:		02-Dec	09-Dec	16-Dec	23-Dec	30-Dec	06-Jan	13-Jan	20-Jan	27-Jan	03-Feb	10-Feb	17-Feb	24-Feb
Order Date:	Qty													
08/31/96	500													
09/09/96	324													
Scheduled Receipts		0	0	0	0	0	0	0	0	0	0	0	0	0

On Hand Quantity:	240	240	-1322	0	0	0	0	0	0	0	0	0	0	0
Planned Order Releases:	0	0	0	0	0	0	0	0	ERR	ERR	ERR	ERR	ERR	ERR

REMARKS: O/O QUANTITIES UNDEDICATED, CAN BE USED TO SUPPORT THIS EXERCISE  
 Class I Requirements to be submitted by 08/15/96

Part No: 503 Lot-for-Lot= 1917  
 Part Name: HOT MEALS LT= 4 week(s)

Exercise Support Requirements:		Backlog	Week 1	2	3	4	5	6	7	8	9	10	11	12	Future
Qty per	Part No.	02-Dec	09-Dec	16-Dec	23-Dec	30-Dec	06-Jan	13-Jan	20-Jan	27-Jan	03-Feb	10-Feb	17-Feb	24-Feb	
27	per 301	0	6	0	0	0	0	0	0	0	0	0	0	0	ERR
27	per 303	0	50	0	0	0	0	0	0	0	0	0	0	0	ERR
27	per 306	0	3	0	0	0	0	0	0	0	0	0	0	0	ERR
27	per 320	0	2	0	0	0	0	0	0	0	0	0	0	0	ERR
27	per 326	0	2	0	0	0	0	0	0	0	0	0	0	0	ERR
27	per 417	0	4	0	0	0	0	0	0	0	0	0	0	0	ERR
27	per 421	0	1	0	0	0	0	0	0	0	0	0	0	0	ERR
27	per 422	0	3	0	0	0	0	0	0	0	0	0	0	0	ERR
Total Requirements		0	1917	0	0	0	0	0	0	0	0	0	0	0	ERR

On Hand	0	0	-1917	-1917	-1917	-1917	-1917	-1917	-1917	-1917	-1917	-1917	-1917	ERR
Planned Order Releases:	1917	0	0	0	0	0	0	ERR	ERR	ERR	ERR	ERR	ERR	ERR

REMARKS: Class I Requirements to be submitted by 08/15/96

Part No: 504 Lot-for-Lot= 59  
 Part Name: RIFLE, 5.56MM, M16A2 LT= 0 week(s)

Exercise Support Requirements:		Backlog	Week 1	2	3	4	5	6	7	8	9	10	11	12	Future
Qty per	Part No.	02-Dec	09-Dec	16-Dec	23-Dec	30-Dec	06-Jan	13-Jan	20-Jan	27-Jan	03-Feb	10-Feb	17-Feb	24-Feb	
1	per 303	0	44	0	0	0	0	0	0	0	0	0	0	0	ERR
1	per 306	0	3	0	0	0	0	0	0	0	0	0	0	0	ERR
1	per 326	0	2	0	0	0	0	0	0	0	0	0	0	0	ERR
1	per 417	0	4	0	0	0	0	0	0	0	0	0	0	0	ERR
1	per 421	0	1	0	0	0	0	0	0	0	0	0	0	0	ERR
1	per 422	0	3	0	0	0	0	0	0	0	0	0	0	0	ERR
Total Requirements		0	59	0	0	0	0	0	0	0	0	0	0	0	ERR

On Hand	0	0	-59	-59	-59	-59	-59	-59	-59	-59	-59	-59	-59	ERR
Planned Order Releases:	0	59	0	0	0	0	0	0	0	0	0	0	0	ERR

REMARKS: FORMULAS BUILT IN TO ACCOMMODATE FOR 1 SAW PER SQUAD.

Part No: 505 Lot-for-Lot= 8  
 Part Name: ELECTROLYTE LT= 2 week(s)

Exercise Support Requirements:		Backlog	Week 1	2	3	4	5	6	7	8	9	10	11	12	Future
Qty per	Part No.	02-Dec	09-Dec	16-Dec	23-Dec	30-Dec	06-Jan	13-Jan	20-Jan	27-Jan	03-Feb	10-Feb	17-Feb	24-Feb	
1	per 310	0	0	3	0	0	0	0	0	0	0	0	0	0	ERR
0	per 321	0	1	0	0	0	0	0	0	0	0	0	0	0	ERR
0	per 322	0	2	0	0	0	0	0	0	0	0	0	0	0	ERR
0	per 323	0	1	0	0	0	0	0	0	0	0	0	0	0	ERR
0	per 325	0	0	0	0	0	0	0	0	0	0	0	0	0	ERR
1	per 328	0	2	0	0	0	0	0	0	0	0	0	0	0	ERR
0	per 330	0	1	0	0	0	0	0	0	0	0	0	0	0	ERR
1	per 418	0	1	0	0	0	0	0	0	0	0	0	0	0	ERR
Total Requirements		1	8	3	0	0	0	0	0	0	0	0	0	0	ERR

Outstanding Orders:		City	Due Date	02-Dec	09-Dec	16-Dec	23-Dec	30-Dec	06-Jan	13-Jan	20-Jan	27-Jan	03-Feb	10-Feb	17-Feb	24-Feb
Order Date	Qty	06/31/96	3	11/22/96												
09/09/96	1	12/05/96														
Scheduled Receipts				1	0	0	0	0	0	0	0	0	0	0	0	0
On Hand Quantity:		1		1	-3	-3	0	0	0	0	0	0	0	0	0	0
Planned Order Releases:		3	0	0	0	0	0	0	0	0	0	0	0	0	0	0

REMARKS: QTY QUANTITIES UNDEDICATED, CAN BE USED TO SUPPORT THIS EXERCISE  
 Class III Requirements to be submitted by 08/01/96

Part No: 506 Lot-for-Lot= 35  
 Part Name: ANTI-FREEZE LT= 2 week(s)

Exercise Support Requirements:		Backlog	Week 1	2	3	4	5	6	7	8	9	10	11	12	Future
Qty per	Part No.	02-Dec	09-Dec	16-Dec	23-Dec	30-Dec	06-Jan	13-Jan	20-Jan	27-Jan	03-Feb	10-Feb	17-Feb	24-Feb	
5	per 310	0	0	3	0	0	0	0	0	0	0	0	0	0	ERR
0	per 321	0	1	0	0	0	0	0	0	0	0	0	0	0	ERR
0	per 322	0	2	0	0	0	0	0	0	0	0	0	0	0	ERR
0	per 323	0	1	0	0	0	0	0	0	0	0	0	0	0	ERR
0	per 325	0	0	0	0	0	0	0	0	0	0	0	0	0	ERR
0	per 328	0	2	0	0	0	0	0	0	0	0	0	0	0	ERR
5	per 330	0	1	0	0	0	0	0	0	0	0	0	0	0	ERR
5	per 418	0	1	0	0	0	0	0	0	0	0	0	0	0	ERR
Total Requirements		0	20	15	0	0	0	0	0	0	0	0	0	0	ERR

Outstanding Orders:		City	Due Date	02-Dec	09-Dec	16-Dec	23-Dec	30-Dec	06-Jan	13-Jan	20-Jan	27-Jan	03-Feb	10-Feb	17-Feb	24-Feb
Order Date	Qty	06/31/96	5	11/22/96												
09/09/96	20	12/05/96														
Scheduled Receipts				20	0	0	0	0	0	0	0	0	0	0	0	0
On Hand Quantity:		1		1	-14	-14	0	0	0	0	0	0	0	0	0	0
Planned Order Releases:		14	0	0	0	0	0	0	0	0	0	0	0	0	0	0

REMARKS: QTY QUANTITIES UNDEDICATED, CAN BE USED TO SUPPORT THIS EXERCISE  
 Class III Requirements to be submitted by 08/01/96

Part No: 507 Lot-for-Lot= 10  
 Part Name: 10WT OIL LT= 2 week(s)

Exercise Support Requirements:		Backlog	Week 1	2	3	4	5	6	7	8	9	10	11	12	Future
Qty per	Part No.	02-Dec	09-Dec	16-Dec	23-Dec	30-Dec	06-Jan	13-Jan	20-Jan	27-Jan	03-Feb	10-Feb	17-Feb	24-Feb	
0	per 310	0	0	3	0	0	0	0	0	0	0	0	0	0	ERR
0	per 321	0	1	0	0	0	0	0	0	0	0	0	0	0	ERR
0	per 322	0	2	0	0	0	0	0	0	0	0	0	0	0	ERR
0	per 323	0	1	0	0	0	0	0	0	0	0	0	0	0	ERR
0	per 325	0	0	0	0	0	0	0	0	0	0	0	0	0	ERR
0	per 328	0	2	0	0	0	0	0	0	0	0	0	0	0	ERR
0	per 330	0	1	0	0	0	0	0	0	0	0	0	0	0	ERR
0	per 418	0	1	0	0	0	0	0	0	0	0	0	0	0	ERR
Total Requirements		0	10	0	0	0	0	0	0	0	0	0	0	0	ERR

Outstanding Orders:		City	Due Date	02-Dec	09-Dec	16-Dec	23-Dec	30-Dec	06-Jan	13-Jan	20-Jan	27-Jan	03-Feb	10-Feb	17-Feb	24-Feb
Order Date	Qty	06/31/96	1	11/22/96												
09/09/96	2	12/05/96														
Scheduled Receipts				2	0	0	0	0	0	0	0	0	0	0	0	0
On Hand Quantity:		5		5	-3	-3	0	0	0	0	0	0	0	0	0	0
Planned Order Releases:		5	0	0	0	0	0	0	0	0	0	0	0	0	0	0

REMARKS: QTY QUANTITIES UNDEDICATED, CAN BE USED TO SUPPORT THIS EXERCISE  
 Class III Requirements to be submitted by 08/01/96

Part No: 508 Lot-for-Lot= 50  
 Part Name: 30WT OIL LT= 2 week(s)

Exercise Support Requirements:		Backlog	Week 1	2	3	4	5	6	7	8	9	10	11	12	Future
Qty per	Part No.	02-Dec	09-Dec	16-Dec	23-Dec	30-Dec	06-Jan	13-Jan	20-Jan	27-Jan	03-Feb	10-Feb	17-Feb	24-Feb	
5	per 310	0	0	3	0	0	0	0	0	0	0	0	0	0	ERR
0	per 321	0	1	0	0	0	0	0	0	0	0	0	0	0	ERR
0	per 322	0	2	0	0	0	0	0	0	0	0	0	0	0	ERR
0	per 323	0	1	0	0	0	0	0	0	0	0	0	0	0	ERR
0	per 325	0	0	0	0	0	0	0	0	0	0	0	0	0	ERR
5	per 328	0	2	0	0	0	0	0	0	0	0	0	0	0	ERR
5	per 330	0	1	0	0	0	0	0	0	0	0	0	0	0	ERR
10	per 418	0	1	0	0	0	0	0	0	0	0	0	0	0	ERR
Total Requirements		0	35	15	0	0	0	0	0	0	0	0	0	0	ERR

Outstanding Orders:		City	Due Date	02-Dec	09-Dec	16-Dec	23-Dec	30-Dec	06-Jan	13-Jan	20-Jan	27-Jan	03-Feb	10-Feb	17-Feb	24-Feb
Order Date	Qty	06/31/96	7	11/22/96												
09/09/96	3	12/04/96														
Scheduled Receipts				3	0	0	0	0	0	0	0	0	0	0	0	0
On Hand Quantity:		5		5	-27	-27	0	0	0	0	0	0	0	0	0	0
Planned Order Releases:		15	0	0	0	0	0	0	0	0	0	0	0	0	0	0

REMARKS: QTY QUANTITIES UNDEDICATED, CAN BE USED TO SUPPORT THIS EXERCISE  
 Class III Requirements to be submitted by 08/01/96

Part No: 509  
 Part Name: 90WT OIL  
 Lot-for-Lot= 50  
 LT= 2 week(s)

Exercise Support Requirements:		Backlog	Week 1	2	3	4	5	6	7	8	9	10	11	12	Future
Qty per	Part No	02-Dec	09-Dec	16-Dec	23-Dec	30-Dec	06-Jan	13-Jan	20-Jan	27-Jan	03-Feb	10-Feb	17-Feb	24-Feb	
0	per 310	0	0	0	0	0	0	0	0	0	0	0	0	0	ERR
5	per 321	0	1	0	0	0	0	0	0	0	0	0	0	0	ERR
10	per 322	0	2	0	0	0	0	0	0	0	0	0	0	0	ERR
5	per 323	0	1	0	0	0	0	0	0	0	0	0	0	0	ERR
0	per 325	0	0	0	0	0	0	0	0	0	0	0	0	0	ERR
5	per 328	0	2	0	0	0	0	0	0	0	0	0	0	0	ERR
5	per 330	0	1	0	0	0	0	0	0	0	0	0	0	0	ERR
5	per 418	0	1	0	0	0	0	0	0	0	0	0	0	0	ERR
Total Requirements		0	50	0	0	0	0	0	0	0	0	0	0	0	ERR

Outstanding Orders:		Order Date	Qty	Due Date	02-Dec	09-Dec	16-Dec	23-Dec	30-Dec	06-Jan	13-Jan	20-Jan	27-Jan	03-Feb	10-Feb	17-Feb	24-Feb
		08/31/96	2	11/22/96													
		09/09/96	2	11/01/96													
Scheduled Receipts					0	0	0	0	0	0	0	0	0	0	0	0	0

On Hand Quantity:	5	5	-45	0	0	0	0	0	0	0	0	0	0	0	ERR	ERR	ERR
Planned Order Releases:		0	0	0	0	0	0	0	0	0	0	ERR	ERR	ERR	ERR	ERR	ERR

REMARKS: O/O QUANTITIES UNDEDICATED, CAN BE USED TO SUPPORT THIS EXERCISE  
 Class III Requirements to be submitted by 08/01/96

Part No: 510  
 Part Name: GREASE, GAA  
 Lot-for-Lot= 22  
 LT= 2 week(s)

Exercise Support Requirements:		Backlog	Week 1	2	3	4	5	6	7	8	9	10	11	12	Future
Qty per	Part No	02-Dec	09-Dec	16-Dec	23-Dec	30-Dec	06-Jan	13-Jan	20-Jan	27-Jan	03-Feb	10-Feb	17-Feb	24-Feb	
2	per 310	0	0	0	0	0	0	0	0	0	0	0	0	0	ERR
2	per 321	0	1	0	0	0	0	0	0	0	0	0	0	0	ERR
3	per 322	0	2	0	0	0	0	0	0	0	0	0	0	0	ERR
1	per 323	0	1	0	0	0	0	0	0	0	0	0	0	0	ERR
0	per 325	0	0	0	0	0	0	0	0	0	0	0	0	0	ERR
2	per 328	0	2	0	0	0	0	0	0	0	0	0	0	0	ERR
1	per 330	0	1	0	0	0	0	0	0	0	0	0	0	0	ERR
2	per 418	0	1	0	0	0	0	0	0	0	0	0	0	0	ERR
Total Requirements		0	16	6	0	0	0	0	0	0	0	0	0	0	ERR

Outstanding Orders:		Order Date	Qty	Due Date	02-Dec	09-Dec	16-Dec	23-Dec	30-Dec	06-Jan	13-Jan	20-Jan	27-Jan	03-Feb	10-Feb	17-Feb	24-Feb
		09/09/96	2	11/15/96													
Scheduled Receipts					0	0	0	0	0	0	0	0	0	0	0	0	0

On Hand Quantity:	5	5	-11	-6	0	0	0	0	0	0	0	0	0	0	ERR	ERR	ERR
Planned Order Releases:		0	0	0	0	0	0	0	0	0	0	ERR	ERR	ERR	ERR	ERR	ERR

REMARKS: O/O QUANTITIES UNDEDICATED, CAN BE USED TO SUPPORT THIS EXERCISE  
 Class III Requirements to be submitted by 08/01/96

Part No: 511  
 Part Name: DIESEL FUEL  
 Lot-for-Lot= 2695  
 LT= 0 week(s)

Exercise Support Requirements:		Backlog	Week 1	2	3	4	5	6	7	8	9	10	11	12	Future
Total per	Part No	02-Dec	09-Dec	16-Dec	23-Dec	30-Dec	06-Jan	13-Jan	20-Jan	27-Jan	03-Feb	10-Feb	17-Feb	24-Feb	
171.7	per 310	0	0	0	0	0	0	0	0	0	0	0	0	0	ERR
152	per 321	0	1	0	0	0	0	0	0	0	0	0	0	0	ERR
144	per 322	0	2	0	0	0	0	0	0	0	0	0	0	0	ERR
108	per 323	0	1	0	0	0	0	0	0	0	0	0	0	0	ERR
0	per 325	0	0	0	0	0	0	0	0	0	0	0	0	0	ERR
1046.5	per 328	0	2	0	0	0	0	0	0	0	0	0	0	0	ERR
356.5	per 330	0	1	0	0	0	0	0	0	0	0	0	0	0	ERR
716.38	per 418	0	1	0	0	0	0	0	0	0	0	0	0	0	ERR
Total Requirements		0	2523.38	171.7	0	0	0	0	0	0	0	0	0	0	ERR

On Hand	0	0	-2523.38	-2695.08	-2695.08	-2695.08	-2695.08	-2695.08	-2695.08	-2695.08	-2695.08	-2695.08	-2695.08	-2695.08	ERR	ERR	ERR
Planned Order Releases:		0	2695.08	0	0	0	0	0	0	0	0	0	0	0	ERR	ERR	ERR

REMARKS: Class III Requirements to be submitted by 08/01/96

600 LEVEL "PARTS"

Part No: 601 Lot-for-Lot= 142  
 Part Name: CLEANING, LUBRICATING, PRESERV. LT= 1 week(s)

Exercise Support Requirements:		Backlog	Week 1	2	3	4	5	6	7	8	9	10	11	12	Future
Qty per	Part No.	02-Dec	09-Dec	16-Dec	23-Dec	30-Dec	06-Jan	13-Jan	20-Jan	27-Jan	03-Feb	10-Feb	17-Feb	24-Feb	
4	per 303	0	0	0	0	0	0	0	0	0	0	0	0	0	ERR
3	per 314	0	0	0	0	0	0	0	0	0	0	0	0	0	ERR
3	per 315	0	0	0	0	0	0	0	0	0	0	0	0	0	ERR
1	per 401	0	6	0	0	0	0	0	0	0	0	0	0	0	ERR
2	per 504	0	59	0	0	0	0	0	0	0	0	0	0	0	ERR
Total Requirements		0	124	18	0	0	0	0	0	0	0	0	0	0	ERR

Outstanding Orders:

Order Date	Qty	Due Date	02-Dec	09-Dec	16-Dec	23-Dec	30-Dec	06-Jan	13-Jan	20-Jan	27-Jan	03-Feb	10-Feb	17-Feb	24-Feb
08/31/96	10	11/11/96													
09/09/96	10	11/12/96													
Scheduled Receipts			0	0	0	0	0	0	0	0	0	0	0	0	0
On Hand Quantity:			21	-103	-18	0	0	0	0	0	0	0	0	ERR	ERR
Planned Order Releases:			103	18	0	0	0	0	0	0	0	0	ERR	ERR	ERR

REMARKS: O/O QUANTITIES UNDEDICATED. CAN BE USED TO SUPPORT THIS EXERCISE  
 Class II Requirements to be submitted by 08/01/96

Part No: 602 Lot-for-Lot= 1917  
 Part Name: PAPERWARE LT= 2 week(s)

Exercise Support Requirements:		Backlog	Week 1	2	3	4	5	6	7	8	9	10	11	12	Future
Qty per	Part No.	02-Dec	09-Dec	16-Dec	23-Dec	30-Dec	06-Jan	13-Jan	20-Jan	27-Jan	03-Feb	10-Feb	17-Feb	24-Feb	
1	per 503	1917	0	0	0	0	0	0	ERR	ERR	ERR	ERR	ERR	ERR	ERR
Total Requirements		1917	0	0	0	0	0	0	ERR	ERR	ERR	ERR	ERR	ERR	ERR

Outstanding Orders:

Order Date	Qty	Due Date	02-Dec	09-Dec	16-Dec	23-Dec	30-Dec	06-Jan	13-Jan	20-Jan	27-Jan	03-Feb	10-Feb	17-Feb	24-Feb
08/31/96	1000	10/29/96													
09/09/96	0	11/05/96													
Scheduled Receipts			0	0	0	0	0	0	0	0	0	0	0	0	0
On Hand Quantity:			500	-1417	0	0	0	0	ERR	ERR	ERR	ERR	ERR	ERR	ERR
Planned Order Releases:			0	0	0	0	ERR	ERR	ERR	ERR	ERR	ERR	ERR	ERR	ERR

REMARKS: O/O QUANTITIES UNDEDICATED. CAN BE USED TO SUPPORT THIS EXERCISE  
 Class II Requirements to be submitted by 08/01/96

Part No: 603 Lot-for-Lot= 1917  
 Part Name: PLASTICWARE LT= 2 week(s)

Exercise Support Requirements:		Backlog	Week 1	2	3	4	5	6	7	8	9	10	11	12	Future
Qty per	Part No.	02-Dec	09-Dec	16-Dec	23-Dec	30-Dec	06-Jan	13-Jan	20-Jan	27-Jan	03-Feb	10-Feb	17-Feb	24-Feb	
1	per 503	1917	0	0	0	0	0	0	ERR	ERR	ERR	ERR	ERR	ERR	ERR
Total Requirements		1917	0	0	0	0	0	0	ERR	ERR	ERR	ERR	ERR	ERR	ERR

Outstanding Orders:

Order Date	Qty	Due Date	02-Dec	09-Dec	16-Dec	23-Dec	30-Dec	06-Jan	13-Jan	20-Jan	27-Jan	03-Feb	10-Feb	17-Feb	24-Feb
08/31/96	900	10/19/96													
09/09/96	200	10/02/96													
Scheduled Receipts			0	0	0	0	0	0	0	0	0	0	0	0	0
On Hand Quantity:			572	-1345	0	0	0	0	ERR	ERR	ERR	ERR	ERR	ERR	ERR
Planned Order Releases:			0	0	0	0	ERR	ERR	ERR	ERR	ERR	ERR	ERR	ERR	ERR

REMARKS: O/O QUANTITIES UNDEDICATED. CAN BE USED TO SUPPORT THIS EXERCISE  
 Class II Requirements to be submitted by 08/01/96

Part No: 604 Lot-for-Lot= 1917  
 Part Name: NAPKINS LT= 2 week(s)

Exercise Support Requirements:		Backlog	Week 1	2	3	4	5	6	7	8	9	10	11	12	Future
Qty per	Part No.	02-Dec	09-Dec	16-Dec	23-Dec	30-Dec	06-Jan	13-Jan	20-Jan	27-Jan	03-Feb	10-Feb	17-Feb	24-Feb	
1	per 505	1917	0	0	0	0	0	0	ERR	ERR	ERR	ERR	ERR	ERR	ERR
Total Requirements		1917	0	0	0	0	0	0	ERR	ERR	ERR	ERR	ERR	ERR	ERR

Outstanding Orders:

Order Date	Qty	Due Date	02-Dec	09-Dec	16-Dec	23-Dec	30-Dec	06-Jan	13-Jan	20-Jan	27-Jan	03-Feb	10-Feb	17-Feb	24-Feb
08/31/96	1000	11/15/96													
09/09/96	372	11/14/96													
Scheduled Receipts			0	0	0	0	0	0	0	0	0	0	0	0	0
On Hand Quantity:			500	-1417	0	0	0	0	ERR	ERR	ERR	ERR	ERR	ERR	ERR
Planned Order Releases:			0	0	0	0	ERR	ERR	ERR	ERR	ERR	ERR	ERR	ERR	ERR

REMARKS: O/O QUANTITIES UNDEDICATED. CAN BE USED TO SUPPORT THIS EXERCISE  
 Class II Requirements to be submitted by 08/01/96



Part No: 605 Lot-for-Lot= 65  
 Part Name: PATCHES, 5.56 MM LT= 3 week(s)

Exercise Support Requirements:

Qty per	Part No.	Backlog	Week 1	2	3	4	5	6	7	8	9	10	11	12	Future
			02-Dec	09-Dec	16-Dec	23-Dec	30-Dec	06-Jan	13-Jan	20-Jan	27-Jan	03-Feb	10-Feb	17-Feb	24-Feb
1	per 315	0	0	6	0	0	0	0	0	0	0	0	0	ERR	ERR
1	per 504	0	59	0	0	0	0	0	0	0	0	0	0	ERR	ERR
<b>Total Requirements</b>		0	59	6	0	0	0	0	0	0	0	0	0	ERR	ERR

Outstanding Orders:

Order Date	Qty	Due Date	02-Dec	09-Dec	16-Dec	23-Dec	30-Dec	06-Jan	13-Jan	20-Jan	27-Jan	03-Feb	10-Feb	17-Feb	24-Feb
08/31/96	0	11/18/96													
09/09/96	0	11/19/96													
<b>Scheduled Receipts</b>			0	0	0	0	0	0	0	0	0	0	0	0	0
<b>On Hand Quantity:</b>			67	67	8	2	2	2	2	2	2	2	2	ERR	ERR
<b>Planned Order Releases:</b>			0	0	0	0	0	0	0	ERR	ERR	ERR	ERR	ERR	ERR

REMARKS: O/O QUANTITIES UNDEDICATED, CAN BE USED TO SUPPORT THIS EXERCISE  
 Class II Requirements to be submitted by 08/01/96

## APPENDIX D. CRYSTAL BALL SUMMARY REPORTS

The summary reports generated from the Crystal Ball simulation of lead time variability are included here.

# Crystal Ball Report

Simulation started on 11/13/96 at 10:39:08

Simulation stopped on 11/13/96 at 10:39:36

## Forecast: Lead Time

Cell: J282

### Summary:

Display Range is from 2.75 to 5.25 Weeks

Entire Range is from 2.82 to 5.11 Weeks

After 500 Trials, the Std. Error of the Mean is 0.02

### Statistics:

	Value
Trials	500
Mean	3.99
Median (approx.)	3.99
Mode (approx.)	4.05
Standard Deviation	0.39
Variance	0.16
Skewness	0.08
Kurtosis	2.89
Coeff. of Variability	0.10
Range Minimum	2.82
Range Maximum	5.11
Range Width	2.29
Mean Std. Error	0.02

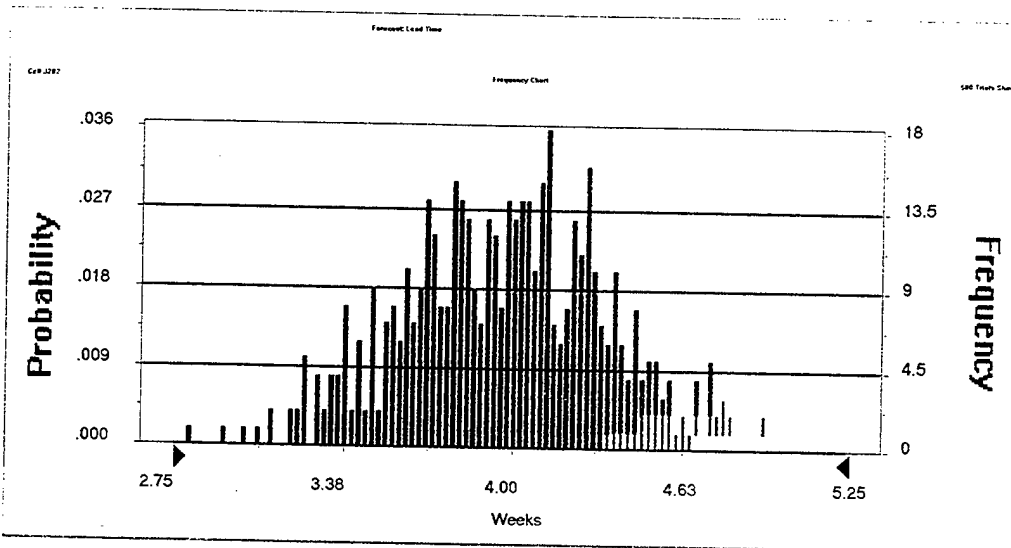

Forecast: Lead Time (cont'd)

Cell: J282

Percentiles:

<u>Percentile</u>	<u>Weeks (approx.)</u>
0%	2.82
10%	3.49
20%	3.67
30%	3.78
40%	3.88
50%	3.99
60%	4.10
70%	4.20
80%	4.30
90%	4.49
100%	5.11

End of Forecast

Assumptions

Assumption: G177; Part 413 Lead Time

Cell: G177

Normal distribution with parameters:

Mean	4.00
Standard Dev.	0.40

Selected range is from 0.00 to +Infinity  
Mean value in simulation was 3.99

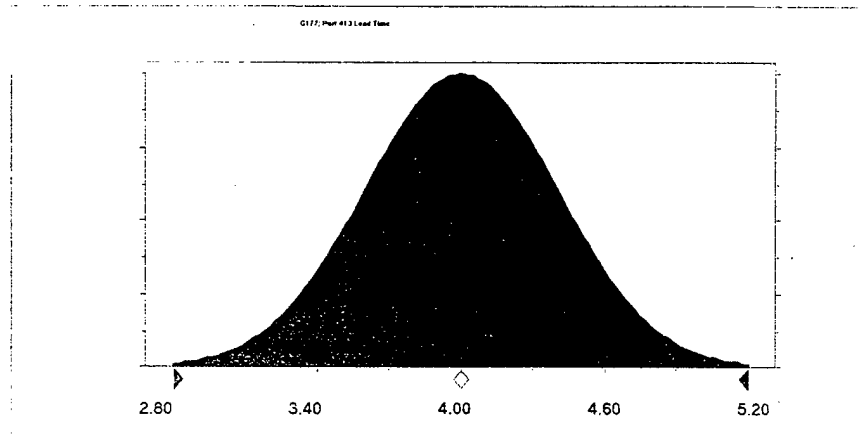

End of Assumptions

# Crystal Ball Report

Simulation started on 11/13/96 at 10:39:08

Simulation stopped on 11/13/96 at 10:39:36

## Forecast: Lead Time

Cell: J282

### Summary:

Certainty Level is 50.40%

Certainty Range is from -Infinity to 4.00 Weeks

Display Range is from 2.75 to 5.25 Weeks

Entire Range is from 2.82 to 5.11 Weeks

After 500 Trials, the Std. Error of the Mean is 0.02

### Statistics:

	Value
Trials	500
Mean	3.99
Median (approx.)	3.99
Mode (approx.)	4.05
Standard Deviation	0.39
Variance	0.16
Skewness	0.08
Kurtosis	2.89
Coeff. of Variability	0.10
Range Minimum	2.82
Range Maximum	5.11
Range Width	2.29
Mean Std. Error	0.02

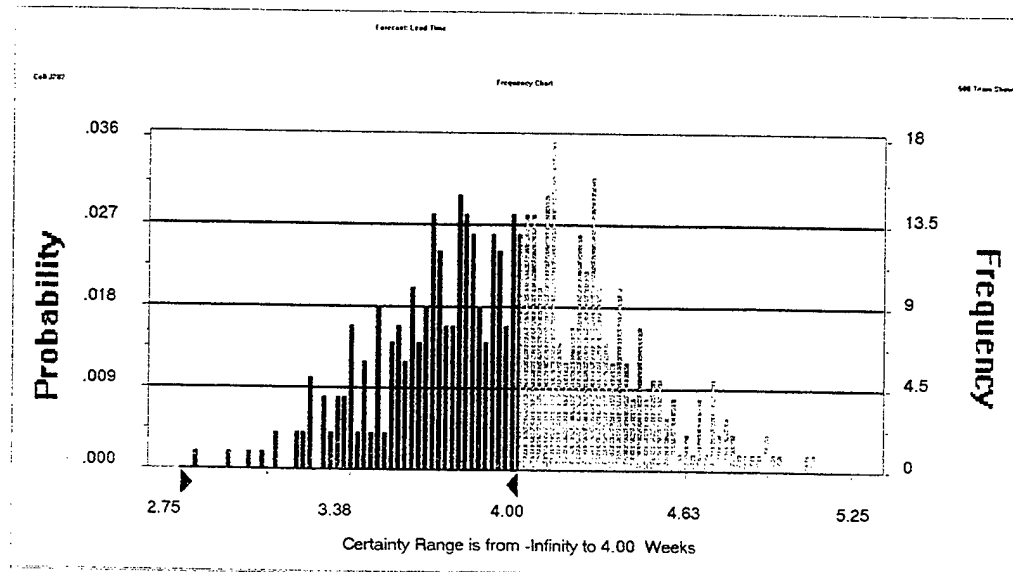

**Forecast: Lead Time (cont'd)**

Cell: J282

Percentiles:

<u>Percentile</u>	<u>Weeks (approx.)</u>
0%	2.82
10%	3.49
20%	3.67
30%	3.78
40%	3.88
50%	3.99
60%	4.10
70%	4.20
80%	4.30
90%	4.49
100%	5.11

End of Forecast

**Assumptions**

**Assumption: G177; Part 413 Lead Time**

Cell: G177

Normal distribution with parameters:

Mean 4.00  
Standard Dev. 0.40

Selected range is from 0.00 to +Infinity  
Mean value in simulation was 3.99

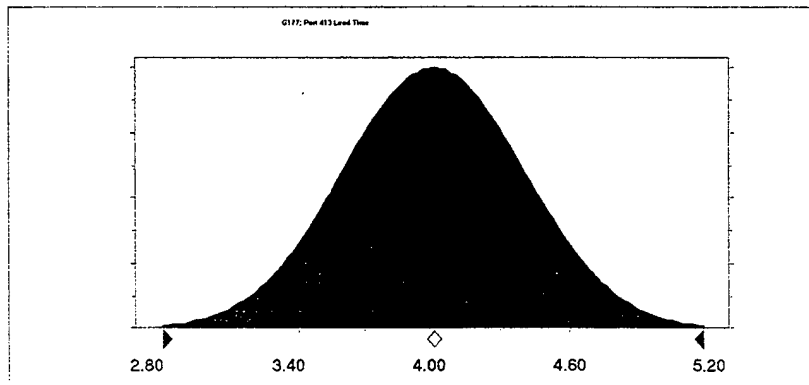

End of Assumptions



## LIST OF REFERENCES

- Ballou, R.H., *Business Logistics Management*, 3rd ed., Prentice Hall, 1992.
- Crystal Ball Version 3.0: Forecasting and Risk Analysis for Spreadsheet Users*, Decisioneering, Inc., 1993.
- Department of the Navy, Headquarters, United States Marine Corps Fleet Marine Force Manual 13, *MAGTF Engineer Operations*, 1992.
- Goeller, D.W., *Spreadsheet Techniques for Logistics Decision Support Systems*, Naval Postgraduate School, 1993.
- Heizer, J., and Render, B., *Production and Operations Management: Strategies and Tactics*, Prentice Hall, 1993.
- Kaminski, P., *Department of Defense Logistics Strategic Plan*, Office of the Under Secretary of Defense (Logistics), Draft 3/14/95, Edition 1995.
- Orlicky, J., *Material Requirements Planning*, McGraw-Hill, 1975.
- Pillifant, C. B., *Implementing Material Requirements Planning in the MCLB Depot Level Maintenance Activity*, Naval Postgraduate School, 1982.
- Plane, D. R., "Spreadsheet Power," *OR/MS Today*, pp. 32-38, December 1994.
- Sangster, A., "Crystal Ball," *OR/MS Today*, pp. 54-56, December 1994.
- Souderpandian, J., "MRP on Spreadsheets: A Do-It-Yourself Alternative for Small Firms," *Production and Inventory Journal*, Second Quarter, 1989.
- Souderpandian, J., "MRP on Spreadsheets: An Update," *Production and Inventory Journal*, Third Quarter, 1994.
- Taylor III, B. W., *Introduction to Management Science*, 4th ed., Prentice Hall, 1993.
- Vazsonyi, A., "Where We Ought to be Going: The Potential of Spreadsheets," *Interfaces*, Vol. 23, No. 5, pp. 26-39, 1993.





## INITIAL DISTRIBUTION LIST

1. Defense Technical Information Center ..... 2  
8725 John J. Kingman Road, Suite 0944  
Fort Belvoir, VA 22060-6218
2. Dudley Knox Library ..... 2  
Naval Postgraduate School  
411 Dyer Road  
Monterey, CA 93943-5101
3. Director, Training and Education ..... 1  
MCCDC, Code C46  
1019 Elliot Rd.  
Quantico, VA 22134-5027
4. Director, Marine Corps Research Center ..... 2  
MCCDC, Code C40RC  
2040 Broadway Street  
Quantico, VA 22134-5107
5. Director, Studies and Analysis Division ..... 1  
MCCDC, Code C45  
300 Russell Rd.  
Quantico, VA 22134-5130
6. Marine Corps Representative ..... 1  
Naval Postgraduate School  
Code 037, Bldg. 234, HA-220  
699 Dyer Road  
Monterey, CA 93940
7. Marine Corps Tactical Systems Support Activity ..... 1  
Technical Advisory Branch  
Attn: Maj J.C. Cummiskey  
Box 555171  
Camp Pendleton, CA 92055-5080

8. Defense Logistic Studies Information Exchange ..... 1  
 U.S. Army Logistics Management College  
 Fort Lee, VA 23801-6043
  
9. Commanding Officer ..... 1  
 Marine Corps Engineer School  
 PSC Box 20069  
 Camp Lejeune, NC 28542-0069
  
10. Commanding Officer ..... 1  
 Marine Corps Detachment  
 U.S. Army Training Center  
 Fort Leonard Wood, MO 65473-5850
  
11. Commanding Officer ..... 1  
 1st Combat Engineer Battalion  
 1st Marine Division, FMFPAC  
 Box 555554  
 Camp Pendleton, CA 92055-5554
  
12. Commanding Officer ..... 1  
 2nd Combat Engineer Battalion  
 2nd Marine Division  
 PSC Box 20089  
 Camp Lejeune, NC 28542-0089
  
13. Commanding Officer ..... 1  
 3rd Combat Assault Battalion  
 3rd Marine Division (-) (rein)  
 Unit 36280  
 FPO AP 96602-6280
  
14. Commanding Officer ..... 1  
 4th Combat Engineer Battalion  
 4th Marine Division, MARFORRES  
 7000 Hemlet St.  
 Baltimore, MD 21234-7499

- 15. Prof. Paul J. Fields (Code SM/Fp) ..... 1  
Naval Postgraduate School  
Monterey, CA 93943-5103
  
- 16. Prof. Kevin R. Gue (Code SM/Gk) ..... 1  
Naval Postgraduate School  
Monterey, CA 93943-5103
  
- 17. Major Arthur M. Tringali ..... 2  
8 Linda Ln.  
Commack, NY 11725