

**NAVAL POSTGRADUATE SCHOOL**  
**Monterey, California**



**THESIS**

**INDIRECT MISSION SUPPORT COSTS  
AT THE  
NAVAL POSTGRADUATE SCHOOL**

by

Brian T. Drapp

June, 1997

Thesis Advisor:

Kenneth J. Euske

Approved for public release; distribution is unlimited.

19980102 040

DTIC QUALITY INSPECTED 4

## REPORT DOCUMENTATION PAGE

Form Approved OMB No. 0704-0188

Public reporting burden for this collection of information is estimated to average 1 hour per response, including the time for reviewing instruction, searching existing data sources, gathering and maintaining the data needed, and completing and reviewing the collection of information. Send comments regarding this burden estimate or any other aspect of this collection of information, including suggestions for reducing this burden, to Washington Headquarters Services, Directorate for Information Operations and Reports, 1215 Jefferson Davis Highway, Suite 1204, Arlington, VA 22202-4302, and to the Office of Management and Budget, Paperwork Reduction Project (0704-0188) Washington DC 20503.

1. AGENCY USE ONLY <i>(Leave blank)</i>	2. REPORT DATE June 1997	3. REPORT TYPE AND DATES COVERED Master's Thesis	
4. TITLE AND SUBTITLE INDIRECT MISSION SUPPORT COSTS AT THE NAVAL POSTGRADUATE SCHOOL		5. FUNDING NUMBERS	
6. AUTHOR(S) Drapp, Brian T.			
7. PERFORMING ORGANIZATION NAME(S) AND ADDRESS(ES) Naval Postgraduate School Monterey CA 93943-5000		8. PERFORMING ORGANIZATION REPORT NUMBER	
9. SPONSORING/MONITORING AGENCY NAME(S) AND ADDRESS(ES)		10. SPONSORING/MONITORING AGENCY REPORT NUMBER	
11. SUPPLEMENTARY NOTES			
12a. DISTRIBUTION/AVAILABILITY STATEMENT Approved for public release; distribution is unlimited.		12b. DISTRIBUTION CODE	
13. ABSTRACT <i>(maximum 200 words)</i> This thesis provides Naval Postgraduate School management and administrators with a tool for reviewing and possibly reducing indirect mission support costs. This thesis develops a computerized activity-based costing model for indirect mission support costs at the Naval Postgraduate School by identifying cost drivers and associated cost flows for resources and support activities. Cost drivers and associated cost flows were identified through archival research and unstructured interviews with Naval Postgraduate School personnel. Estimated cost allocation figures are calculated which can be used as a starting point to improve cost allocations at Naval Postgraduate School.			
14. SUBJECT TERMS Activity-Based Costing Model, Indirect Mission Support Costs		15. NUMBER OF PAGES 215	
		16. PRICE CODE	
17. SECURITY CLASSIFICATION OF REPORT Unclassified	18. SECURITY CLASSIFICATION OF THIS PAGE Unclassified	19. SECURITY CLASSIFICATION OF ABSTRACT Unclassified	20. LIMITATION OF ABSTRACT UL

NSN 7540-01-280-5500

Standard Form 298 (Rev. 2-89)  
Prescribed by ANSI Std. Z39-18 298-102



Approved for public release; distribution is unlimited.

**INDIRECT MISSION SUPPORT COSTS  
AT THE  
NAVAL POSTGRADUATE SCHOOL**

Brian T. Drapp  
Lieutenant, Supply Corps, United States Navy  
B.A., University of South Florida, 1984

Submitted in partial fulfillment  
of the requirements for the degree of

**MASTER OF SCIENCE IN MANAGEMENT**

from the

**NAVAL POSTGRADUATE SCHOOL**

June 1997

Author:

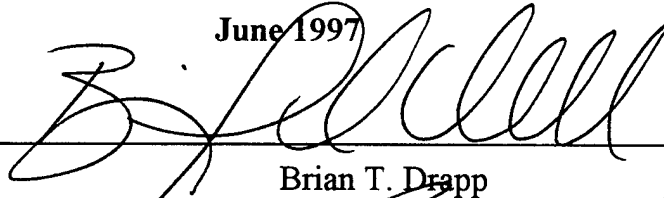
  
Brian T. Drapp

Approved by:

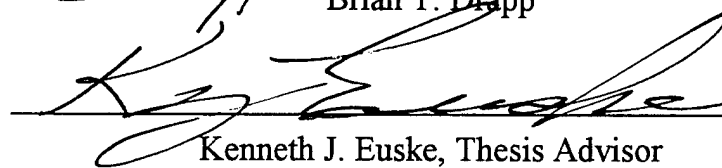
  
Kenneth J. Euske, Thesis Advisor

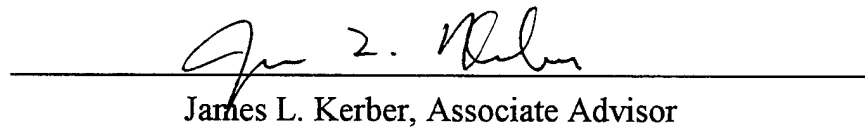
  
James L. Kerber, Associate Advisor

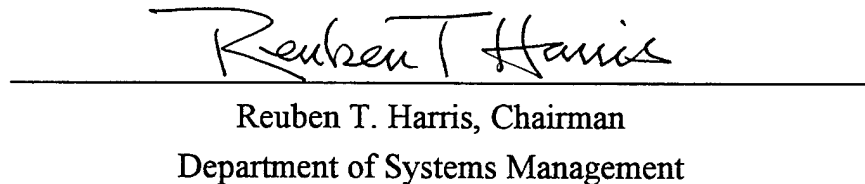
  
Reuben T. Harris, Chairman  
Department of Systems Management



## **ABSTRACT**

This thesis will provides Naval Postgraduate School management and administrators with a tool for reviewing and possibly reducing indirect mission support costs. This thesis develops a computerized activity-based costing model for indirect mission support costs at the Naval Postgraduate School by identifying cost drivers and associated cost flows for resources and support activities. Cost drivers and associated cost flows were identified through archival research and unstructured interviews with Naval Postgraduate School personnel. Estimated cost allocations figures are calculated which can be used as a starting point to improve cost allocations at Naval Postgraduate School.



## TABLE OF CONTENTS

I. INTRODUCTION .....	1
A. OBJECTIVE .....	1
B. BACKGROUND .....	1
C. RESEARCH ISSUE .....	3
D. SCOPE OF THESIS .....	3
E. ORGANIZATION OF THE STUDY .....	7
II. METHODOLOGY AND DATA COLLECTION .....	9
A. ACTIVITY-BASED COSTING MODEL OVERVIEW .....	9
1. Activity-Based Costing .....	9
2. Activity-Based Management .....	10
3. Process Modeling .....	10
a. Demand Boxes .....	11
b. Supply Boxes .....	12
c. Summary Boxes .....	13
d. Fixed and Variable Costs .....	14
4. Cost Allocation Factors .....	14
B. DATA COLLECTION PROCESS .....	15
1. Archival Research .....	15
2. Interviews .....	15



C.	COST DRIVERS .....	16
D.	STEP DOWN COST ALLOCATION METHOD .....	16

### III. NAVAL POSTGRADUATE SCHOOL ACTIVITY-BASED COSTING

	MODEL .....	19
A.	MODEL ASSUMPTIONS .....	19
	1. Source Documentation .....	19
	2. Personnel .....	19
	3. Reimbursable Costs .....	20
	4. Tenant Commands .....	20
	5. Military Instructor Research .....	21
	6. Square Footage .....	21
	7. Number of Personnel and Students .....	21
B.	DEMAND BOXES .....	22
C.	SUPPLY BOXES .....	23
	1. Square Footage Used As Cost Driver .....	23
	2. Number of Students Supported Used As Cost Driver .....	25
	3. Number of Total Personnel Supported Used As Cost Driver ...	26
	4. Number of Phone Lines Used As Cost Driver .....	26
D.	SUMMARY BOXES .....	27
	1. Environmental .....	28
	2. Public Works Department .....	28

3.	Naval Support Activity, Monterey Bay .....	29
4.	Human Resources Office .....	30
5.	Comptroller .....	30
6.	Timekeeping (Payroll) .....	30
7.	Computer Information Services .....	31
8.	Morale, Welfare and Recreation .....	31
9.	Police Department .....	32
10.	Fire Department .....	34
11.	Supply Department .....	34
12.	Superintendent .....	34
13.	Provost .....	35
14.	Dudley Knox Library .....	36
15.	Dean of Students .....	37

IV. RESULTS OF THE NAVAL POSTGRADUATE SCHOOL ACTIVITY-

	BASED COSTING MODEL .....	39
A.	MANAGEMENT AND SECURITY STUDIES OUTPUT BOX .....	40
B.	ENGINEERING AND COMPUTATIONAL SCIENCES OUTPUT BOX .....	40
C.	OPERATIONAL AND APPLIED SCIENCES OUTPUT BOX .....	41
D.	RESEARCH DEPARTMENT OUTPUT BOX .....	41
E.	SCHOOL OF AVIATION SAFETY OUTPUT BOX .....	41

F.	RESIDUAL COSTS BOX .....	42
V.	CONCLUSIONS AND RECOMMENDATIONS .....	43
A.	CONCLUSIONS .....	43
1.	Identification of Cost Drivers and Cost Flows .....	43
2.	Developing a Computer-Based Activity-Based Costing Model .	43
B.	RECOMMENDATIONS .....	44
1.	Costs .....	44
2.	Cost Reimbursement .....	44
3.	Tenant Commands .....	44
4.	Military Instructor Research .....	45
5.	Square Footage .....	45
6.	Environmental .....	45
7.	Public Works Department .....	46
8.	Comptroller .....	46
9.	Computer Information Services .....	46
10.	Supply Department .....	46
11.	Morale, Welfare and Recreation and Dudley Knox Library . . . .	47
12.	Superintendent and Provost .....	47
13.	Cost Drivers .....	47
C.	REMARKS .....	48

LIST OF REFERENCES .....	51
APPENDIX A. ACADEMIC AREAS .....	55
APPENDIX B. COSTS TRACED TO MISSION SUPPORT ACTIVITIES AND COST OBJECTS .....	57
APPENDIX C. COMPOSITE STANDARD MILITARY RATES .....	69
APPENDIX D. DEMAND BOX ABBREVIATIONS .....	71
APPENDIX E. SUPPLY BOX ABBREVIATIONS .....	73
APPENDIX F. SUMMARY BOX ABBREVIATIONS .....	75
APPENDIX G. STEP DOWN COST ALLOCATION ORDER .....	77
APPENDIX H. SQUARE FOOTAGE ESTIMATES .....	79
APPENDIX I. NUMBER OF PERSONNEL FOR FY 96 .....	81
APPENDIX J. AVERAGE NUMBER OF STUDENTS ON BOARD FOR FY 96 ...	83

APPENDIX K. DEMAND BOXES .....	85
APPENDIX L. SUPPLY BOXES .....	93
APPENDIX M. NUMBER OF PHONE LINES .....	107
APPENDIX N. SUMMARY BOXES .....	109
APPENDIX O. FINANCIAL RESULTS FOR FY 96 .....	149
APPENDIX P. MANAGEMENT AND SECURITY STUDIES FY 96	
QUARTERLY FINANCIAL RESULTS .....	163
APPENDIX Q. ENGINEERING AND COMPUTATIONAL SCIENCES FY 96	
QUARTERLY FINANCIAL RESULTS .....	169
APPENDIX R. OPERATIONAL AND APPLIED SCIENCE FY 96 QUARTERLY	
FINANCIAL RESULTS .....	175
APPENDIX S. RESEARCH DEPARTMENT FY 96 QUARTERLY FINANCIAL	
RESULTS .....	181

APPENDIX T. SCHOOL OF AVIATION SAFETY FY 96 QUARTERLY

FINANCIAL RESULTS ..... 187

APPENDIX U. RESIDUAL FY 96 QUARTERLY FINANCIAL RESULTS ..... 193

INITIAL DISTRIBUTION LIST ..... 199

## **I. INTRODUCTION**

### **A. OBJECTIVE**

The objective of this thesis is to develop an activity-based costing model for indirect mission support costs at the Naval Postgraduate School. To achieve this objective, a computer-based costing model of Naval Postgraduate School indirect mission support costs was developed. The indirect costs include the costs of most resources (e.g., electricity, water, natural gas), and support activities (e.g., Public Works Department, Dudley Knox Library, Police Department). The model was designed primarily for Naval Postgraduate School administrators and managers to evaluate the cost-flows and allocation of indirect mission support costs.

### **B. BACKGROUND**

The Naval Postgraduate School was established to serve the advanced educational needs of the Navy. The broad responsibility of the school is reflected in its stated mission:

Increase the combat effectiveness of the U.S. and Allied armed forces and enhance the security of the U.S.A. through advanced education and research programs focused on the technical, analytical, and managerial tools needed to confront defense related challenges of the future (Calhoon, 1997).

The Naval Postgraduate School offers classes leading to advanced degrees in a variety of fields. Eleven Academic Departments and five interdisciplinary Academic Groups of study are organized into Management and Security Studies, Engineering and Computational Sciences, or Operational and Applied Science, as shown in Appendix A. The student body consists of United States military officers from all branches of the uniformed services, civilian

employees of the federal government, and military officers and government civilian employees of other countries (Calhoun, 1997). The Naval Support Activity, Monterey Bay and several tenant commands are also located at the Naval Postgraduate School.

The support commands and the responsibility centers of the Naval Postgraduate School are classified as either "mission" or "non-mission". Mission responsibility centers (i.e., academic related) include the Provost, Director of Academic Planning, Dean of Students, Director of the Dudley Knox Library, Associate Provost for Instruction, Associate Provost for Innovation, Computer Information Services, Management and Security Studies, Engineering and Computational Sciences, Operational and Applied Science, Research Department, and School of Aviation Safety. Non-mission responsibility centers (i.e., non-academic related) include the Naval Support Activity, Monterey Bay and all tenant commands.

Over forty-seven million dollars of indirect mission support costs were generated by mission and non-mission responsibility centers at the Naval Postgraduate School during Fiscal Year 1996. Difficulties arise when attempting to identify the indirect costs of a responsibility center since some non-mission responsibility centers support mission responsibility centers and vice versa. Additionally, many of the indirect costs are centrally managed by the comptroller. Therefore, they are not charged to the activities causing the costs to be incurred (Reilly, 1997). The end result is that Naval Postgraduate School administrators and management do not know the indirect costs generated by specific responsibility centers (Elster, 1996). This thesis attempts to estimate indirect costs driven or caused by mission activities at the Naval Postgraduate School.



**C. RESEARCH ISSUE**

The primary research question addressed in this thesis is what are the cost drivers and associated cost flows for resources and support activities at the Naval Postgraduate School?

**D. SCOPE OF THESIS**

This thesis estimates the indirect costs at the Naval Postgraduate School that can be identified with mission activities. Indirect costs were estimated by identifying all direct costs of resources and support activities, then allocating those costs to other support activities and cost objects. The cost objects in the model are Management and Security Studies, Engineering and Computational Sciences, Operational and Applied Science, Research Department, and School of Aviation Safety.

This thesis identifies cost drivers and associated cost flows for indirect costs of major activities at the Naval Postgraduate School and Naval Support Activity, Monterey Bay for Fiscal Year 1996 (FY 96). Indirect costs for FY 96 are presented by quarter, beginning with October through December 1996, to show the quarterly fluctuations of indirect costs for major activities. All costs were considered indirect costs except for costs that could be directly traced to teaching and thesis advising (Jay, 1997). Teaching and thesis advising costs include the labor costs of faculty performing direct teaching and thesis advising activities. There are other costs (e.g., departmental support staffs) which can be identified directly with academic areas but are indirect to the ultimate activities of the Naval Postgraduate School, teaching and thesis advising. The costs which are in this category are presented in Appendix B.

The primary source document used for identifying the cost figures used in this thesis was the Naval Postgraduate School's end of quarter Operating Target (OPTAR) report for FY 96 (Reilly, 1997). However, in some cases, the first and second quarter cost figures were estimated since no master copy of the end of the first quarter OPTAR report existed (Forrester, 1997). Therefore, the ending OPTAR obligations for resources, support activities, and cost objects at the end of the second quarter was divided equally to obtain the first and second quarter ending OPTAR obligation balances.

Military and civilian personnel salaries were included in the direct costs of support activities and cost objects. The Navy and Marine Corps Composite Standard Military Rates, as shown in Appendix C, were used for all military personnel salaries since obtaining the exact salary figures was not possible due to the Privacy Act of 1974 (Hodge, 1997). Civilian personnel salaries were based on FY 96 labor control cost figures. Salaries for civilians working in Management and Security Studies, Engineering and Computational Sciences, and Operational and Applied Science were based on actual labor expenditures, (Howard, 1997). Additionally, fringe benefits were added to all civilian salary figures at the rates of twenty-one percent for civilian faculty and twenty-three percent for civilian staff (Howard, 1997).

The Officer Distribution Control Report and the Naval Support Activity Monterey Bay Officer Billet List were the primary source documents used for identifying military officers to specific activities (Lewis, 1997). The Naval Support Activity Monterey Bay, Enlisted Billets was the primary source document used for identifying enlisted personnel to

specific activities (Gray, 1997). Additionally, identifying enlisted personnel assigned to Engineering and Computational Sciences and Operational and Applied Science was accomplished by an interview with supervisory personnel (Labuguen, 1997).

Postal, FEDEX/United Parcel Service (UPS), and copier costs are managed by the Supply Department and assigned to applicable support activities and cost objects (Phillis, 1997).

Once the traceable costs were identified with resources, support activities, and cost objects, cost drivers for resources and support activities were identified. Based on the identified cost driver, cost allocation factors were calculated and assigned to resources and support activities using the step-down cost allocation method. Finally, after completing the step-down allocation, all costs and cost allocation factors for resources, support activities, and cost objects were loaded into an activity-based computer model.

The costs for each resource loaded into the computer model (Figure 1) include all costs that were identified with a specific resource. For instance, the electricity cost figure was determined by using OPTAR expenditure figures for electricity.

The costs for each support activity loaded into the computer include all costs that were identified with a specific support activity. For instance, the Public Works Department cost figure was determined by summing the OPTAR expenditures for Public Works Department, labor costs (using labor control figures), and all other costs which could be traced to Public Works Department (i.e., postal expense, FEDEX/UPS, copier expense).

The costs for each cost object loaded into the computer model include all costs that were identified to a specific cost object. For instance, the Management and Security Studies cost figure was determined by summing OPTAR expenditures figures, labor costs (using labor control figures), and all other costs which could be traced to Management and Security Studies (i.e., postal expense, FEDEX/UPS, copier expense).

After all costs were loaded into the activity-based computer model, the total indirect costs for each cost object was calculated. Figure 1 illustrates this process.

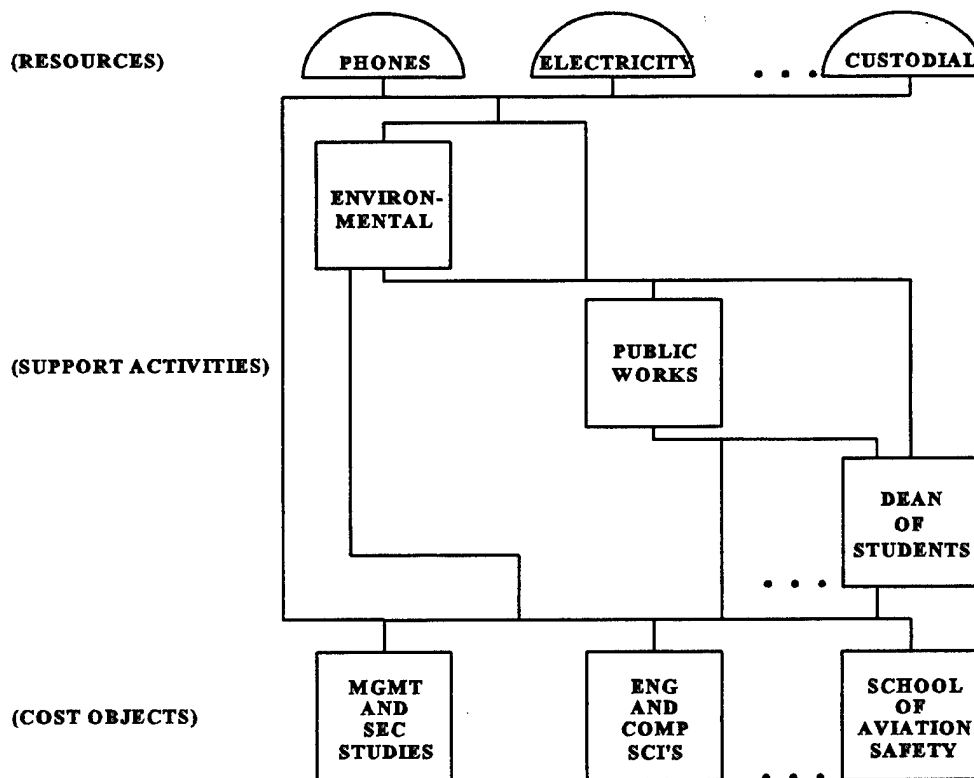

Figure 1. Activity-Based Computer Model Process

## **E. ORGANIZATION OF THE STUDY**

This thesis has four chapters. Chapter I presents the objective of the thesis and provides Naval Postgraduate School background information. Additionally, Chapter I discusses the research issue and scope of the thesis. Chapter II discusses the research methodology used in the thesis. Chapter III describes the activity-based costing model for the Naval Postgraduate School, including cost drivers and cost allocations used in the thesis. Chapter IV provides the results of the activity-based costing model outputs. Finally, Chapter V discusses the conclusions and recommendations of the thesis.



## **II. METHODOLOGY AND DATA COLLECTION**

This chapter discusses the research methodology used in this thesis. The first section provides an overview of the activity-based model developed in this thesis. Additionally, the concepts of activity-based costing, activity-based management, and process modeling are discussed. The second section discusses the data collection methods used in this thesis. The third section contains a discussion of cost drivers. The fourth section discusses the step-down cost allocation method.

### **A. ACTIVITY-BASED COSTING MODEL OVERVIEW**

This thesis used Sapling's NetProphet II software to develop an activity-based cost model for indirect costs at Naval Postgraduate School. The NetProphet II modeling software incorporates the concepts of activity-based costing, activity-based management, and process modeling (Sapling, 1996). The model incorporated resource and support activity cost flows, and the other costs that could be traced to the cost objects (i.e., Management and Security Studies, Engineering and Computational Sciences, Operational and Applied Science, Research Department, and School of Aviation Safety). The direct costs of teaching and thesis advising were excluded.

#### **1. Activity-Based Costing**

Activity-based costing is a procedure that measures the costs of objects such as products, services, and customers. Activity-based costing first assigns resource costs to the major activities performed by the organization. Then activity costs are assigned to the

products, customers, and services that benefit from or are creating the demand for the activities (Atkinson, *et al.*, 1997).

## **2. Activity-Based Management**

Activity-based management is the processes of using the information provided by an activity-based cost analysis to improve organizational efficiency. Activity-based management includes performing activities more efficiently, eliminating the need to perform certain activities that do not add value for customers, improving the design of services, and developing better relationships with customers and suppliers. The goal of activity-based management is to enable customer needs to be satisfied while making fewer demands on organizational resources (Atkinson, *et al.*, 1997). Additionally, activity-based management has become increasingly accepted in recent years because it provides managers with tools and information they need for better decision making. Therefore, the information required needs to be more accurate for specific activities throughout the organization. The information is needed to prioritize areas where improvements can be made and costs reduced (Sapling, 1996).

## **3. Process Modeling**

Process modeling is primarily an operational analysis technique. It starts with a schematic that represents a comprehensive understanding of the processes and activities of the organization and how they relate to one another. Process modeling is then used to trace costs from resources to activities, to subsequent related activities, and finally to cost objects.



NetProphet uses the process modeling approach because it is designed to capture financial and operational information, and integrates them to provide a two-dimensional management view of the organization (Sapling, 1996).

The three basic building blocks NetProphet uses to model cost flows are Demand Boxes, Supply Boxes, and Summary Boxes (Stalh, 1996). A detailed description and discussion of each type of box is presented in the following three sub-subsections.

*a. Demand Boxes*

Demand boxes are located at the bottom of the model and represent the final cost objects (i.e., cost outputs) of the model. There are six demand boxes used in this model:

- \* Management and Security Studies
- \* Engineering and Computational Sciences
- \* Operational and Applied Science
- \* Research Department
- \* School of Aviation Safety
- \* Residual Costs

The first five demand boxes contain all mission related indirect costs of the Naval Postgraduate School and Naval Support Activity, Monterey Bay which were identified during the thesis research. The sixth demand box, Residual Costs, was used in the model to represent the accumulation of costs that did not flow into the five mission demand boxes

(Stalh, 1996). Demand boxes are represented schematically in the model by the following symbol:

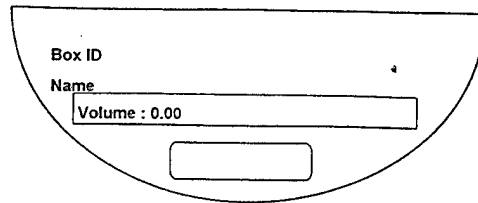

Figure 2. Demand Box

The Box ID identifies each demand box. A list of the Box ID abbreviations, along with the associated name, is provided in Appendix D. The volumes for each of the six demand boxes in the model are given a value of one, which represents one activity demanding resources.

***b. Supply Boxes***

Supply boxes are located at the top of the model and represent the resources used by the support activities and cost objects. There are eleven supply boxes used in the model which represent the resources to be allocated to support activities and cost objects.

The eleven supply boxes are:

- \* Phones
- \* Electricity
- \* Natural Gas
- \* Main Gas
- \* Water
- \* Sewage
- \* Refuse

- \* Grounds Maintenance (Naval Postgraduate School)
- \* Custodial (Naval Postgraduate School)
- \* Grounds Maintenance (La Mesa)
- \* Custodial (La Mesa)

Each supply box contains the direct costs of resources, as shown in Appendix B.

Supply boxes are represented schematically in the model by the following symbol:

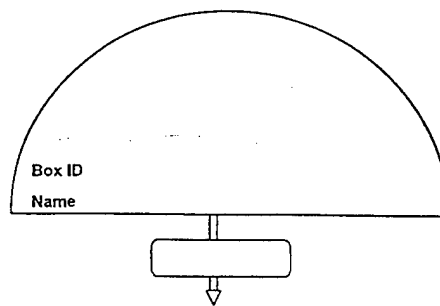

Figure 3. Supply Box

The Box ID identifies each supply box. A list of the Box ID abbreviations, along with the associated name, is provided in Appendix E.

*c. Summary Boxes*

The summary boxes (i.e., major activities) are located above demand boxes and are related to demand (Sapling, 1996). Summary boxes were used in this model to accumulate the costs of resources, support activities, and cost objects. The thirty-seven summary boxes used in this model are shown in Appendix F. In some cases (e.g., Superintendent's office), model constraints required that two summary boxes be used for a

single activity. Summary boxes are represented schematically in the model by the following symbol:

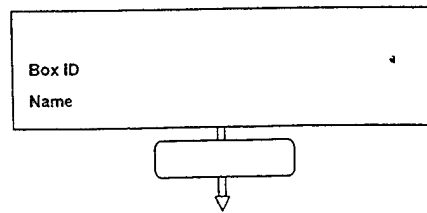

Figure 4. Summary Box

*d. Fixed and Variable Costs*

NetProphet classifies costs as either fixed or variable. NetProphet considers all costs identified to summary and demand boxes as fixed, and all costs assigned to supply boxes as variable (Sapling, 1996). Therefore, this model considers the costs identified to support activities and cost objects as fixed costs, and the costs identified to resources as variable costs.

**4. Cost Allocation Factors**

NetProphet uses cost allocation factors to link the three types of boxes described above. Every supply and summary box containing costs to be allocated was assigned a cost allocation factor. The cost allocation factor was then calculated outside of the activity-based costing model based on the selected cost driver and assigned to a specific model link. The sum total of all cost allocation link factors exiting for a specific activity must always equal one. For example, square footage was selected as the cost driver for allocating electricity. All electricity was allocated (i.e., linked) to activities based on each activities' share of the total square footage of all activities. This resulted in the sum of all links generating from the electricity supply box to equal one hundred percent since all electricity was allocated.

## **B. DATA COLLECTION PROCESS**

This section discusses the data collection process used to develop the activity-based costing model in this thesis. The data collection process consisted of archival research and interviews with key individuals of the major activities identified.

### **1. Archival Research**

Archival research is concerned with the examination of recorded facts (Buckley, *et al.*, 1976). As discussed, all costs were considered indirect costs except for teaching and thesis advising costs (Jay, 1997). After determining which costs were to be considered indirect costs, archival research commenced.

Archival research began by using the source documents discussed in Chapter I to obtain cost figures for the Naval Postgraduate School and Naval Support Activity, Monterey Bay. The next step involved matching these cost figures to resources, support activities, and cost objects identified in the Naval Postgraduate School Organization Chart. The large support activities (e.g., Naval Support Activity, Monterey Bay) were decomposed to more specific support activities performing the same general functions. For example, Environmental, Public Works Department, Supply Department, Police Department, Fire Department, and Morale, Welfare and Recreation were treated as separate activities from Naval Support Activity, Monterey Bay. Additionally, Computer Information Services and Dudley Knox Library were treated as separate activities from the Provost.

### **2. Interviews**

Interviews were also used in the data collection process. Unstructured interviews were used to identify and/or validate resource, support activity, and cost object costs.

Interviews were conducted with key individuals representing the support activities. The interviews primarily consisted of the individuals being interviewed explaining the functions of their particular activity. In addition to validating and identifying costs, interviews were used in determining the cost drivers to be used to allocate costs.

### **C. COST DRIVERS**

A cost driver is a factor that causes or drives an activity's costs (Deakin and Maher, 1994). Determining cost drivers was an iterative process. Therefore, prior to determining the cost driver for resources and support activities, interviews were conducted with key individuals to gain an understanding of the functional characteristics of the resources and support activities. Next, interviews were conducted (usually with the same individuals) to determine which cost driver would be the most appropriate based on available information.

Once a cost driver for a resource or support activity had been identified, additional information was usually required to complete the calculations of the cost allocation factors. The additional information (e.g., number of military/civilian personnel, square footage) was obtained using both archival research and by conducting additional interviews.

### **D. STEP DOWN COST ALLOCATION METHOD**

Many of the support activities at the Naval Postgraduate School provide service to other support activities as well as to themselves (e.g., Comptroller, Computer Information Services). Therefore, the step down cost allocation method was used in calculating the cost allocation factors in the NetProphet costing model. The step down method was chosen over the reciprocal allocation method because NetProphet is unable to generate allocations if loops exist among the activities that are linked together. The principle behind the step down

method is to recognize that support activities provide services for other support activities as well as for the final cost objects. The costs of the activity are allocated one activity at a time. As a result, the costs of all activities, except the first to be allocated, will reflect their shares of the costs of some of the other activities (Dominiak and Louderback, 1994). The following sequence of events illustrate the cost allocation described above:

- \* A cost driver for a specific support activity, activity A, is determined. For instance, square footage was selected as the cost driver to allocate electricity.
- \* Cost allocation factors are calculated to allocate all costs of activity A to all remaining support activities and cost objects.
- \* The cost allocation factors are then assigned to all model links exiting activity A.
- \* The costs for activity A are then allocated to all the remaining support activities and cost objects.
- \* Repeat the above process with subsequent support activities until all the indirect costs have been allocated.

The order in which support activities were allocated, as shown in Appendix G, was based on how the functions of the support activity affected other support activities (Dominiak and Louderback, 1994). For example, Public Works Department was one of the first support activities to be allocated since all other support activities receive the benefits of Public Works Department functions (e.g., routine maintenance and repairs, emergency services).





### **III. NAVAL POSTGRADUATE SCHOOL ACTIVITY-BASED COSTING MODEL**

This chapter describes the activity-based costing model developed for the Naval Postgraduate School that was developed using Sapling's NetProphet II software. The first section discusses specific model assumptions. The last three sections provide a detailed description and discussion of the model and the cost drivers and allocations used in the model.

#### **A. MODEL ASSUMPTIONS**

Assumptions were made regarding the modeling of cost flows. This section discusses specific assumptions that were used in developing the activity-based costing model for the Naval Postgraduate School.

##### **1. Source Documentation**

An assumption was made that the cost data obtained from source documentation was accurate. Therefore, the accuracy of the activity-based costing model developed in this thesis is dependent on the accuracy of the source documentation data.

##### **2. Personnel**

Since the number of personnel assigned to specific activities periodically changes over time due to either personnel rotating between activities and/or commencing or terminating employment, an assumption was made that all personnel (i.e., military and civilian) assigned to an activity, based on labor control figures, worked in the same activity for the entire quarter during each quarter of FY 96. The labor control cost figures could be used for the

analysis because they were not materially different from the actual labor costs for activities at the Naval Postgraduate School and Naval Support Activity, Monterey Bay in FY 96 (Reilly, 1997).

### **3. Reimbursable Costs**

There are situations at the Naval Postgraduate School and Naval Support Activity, Monterey Bay, where costs are subsequently reimbursed to either the Naval Postgraduate School or Naval Support Activity, Monterey Bay. For instance, the Naval Postgraduate School receives reimbursements for costs generated by professors and staff conducting research sponsored by either military and/or civilian organizations (Howard, 1997). Also, the Naval Support Activity, Monterey Bay receives reimbursements for costs generated by tenant commands using the resources (e.g., utilities) of Naval Support Activity, Monterey Bay. Reimbursable costs (e.g., the cost of staff personnel performing reimbursable research activities) are not included in this model since reimbursements do not materially affect cost flows to cost objects.

### **4. Tenant Commands**

The costs of the tenant commands that were associated with activities supporting either the Naval Postgraduate School or Naval Support Activity, Monterey Bay (e.g., Personnel Support Detachment, Regional Officer in Charge of Construction, Dental Command), were not allocated due to the time required to identify and determine overhead cost allocations. These allocations were beyond the scope of this thesis.

## **5. Military Instructor Research**

The impact of costs resulting from military personnel conducting reimbursable research was not included in this model since most military instructors are used only for classroom instruction (Burke, 1997).

## **6. Square Footage**

Square footage is used as a cost driver to allocate costs for some resources and support activities. The square footage estimates used in this thesis were derived by merging square footage figures provided by the Public Works Department (Schmidt, 1997) and the Director of Academic Planning (Howard, 1997). The square footage estimates are shown in Appendix H. These figures are an approximation for assigned square footage because the data provided either square footage totals by building number or interior classroom square footage. Combining the two data bases did not provide an exact calculation of the square footage assigned to support activities and cost objects.

Total square footage used was 1,279,066 (Tedrow, 1997). This figure includes all square footage of buildings located inside the base fences at Naval Postgraduate School and also the 39,137 square feet of buildings located at the Navy golf course (Schmidt, 1997). Mission activities were allocated 838,898 square feet (Schmidt, 1997) and 440,168 square feet were allocated to non-mission activities.

## **7. Number of Personnel and Students**

The number of military and civilian personnel and students by various categories is used as a cost driver to allocate costs. The total number of personnel by category is shown in Appendix I. As discussed in Chapter I, the number of personnel was obtained from Officer

Distribution Control Reports, Naval Support Activity, Monterey Bay Officer and Enlisted Billet Lists, and interviews with supervisory personnel. The average number of students on board for the year is shown in Appendix J.

**B. DEMAND BOXES**

Demand boxes are located at the bottom of the model and represent the final cost objects of the model. There are six demand boxes used in this model (i.e., Management and Security Studies, Engineering and Computational Sciences, Operational and Applied Science, Research Department, School of Aviation Safety, and Residual Costs) as shown in Appendix K.. Demand boxes are used to collect the FY 96 costs that can be traced directly to the cost objects plus the allocated resource and support activity costs which have flowed through the NetProphet activity-based costing model. The total FY 96 costs for each demand box are presented below:

* Management and Security Studies	\$ 10, 013,553
* Engineering and Computational Sciences	16, 394,747
* Operational and Applied Science	14,475,826
* Research Department	1,191,031
* School of Aviation Safety	1,293,150
* Residual Costs	3,637,132
* Total	\$ 47,005,439

The residual costs figure represents the accumulation of costs that did not flow into the five mission demand boxes. The figure does not include any costs caused or reimbursed by tenant commands.

### C. SUPPLY BOXES

Supply boxes represent the top level of the model (Tufts, 1995). Supply boxes are used to represent the resources used by the support activities and cost objects. There are eleven supply boxes used in this model and are shown in Appendix L. The costs identified to resources for FY 96 for each supply box are presented below:

* Electricity	\$ 1,131,572
* Natural Gas	105,603
* Main Gas	187,036
* Custodial (Naval Postgraduate School)	1,143,169
* Grounds Maintenance (Naval Postgraduate School)	187,036
* Custodial (La Mesa)	2,951
* Grounds Maintenance (La Mesa)	151,873
* Water	110,062
* Sewage	73,833
* Refuse	142,924
* Phones	845,500
* Total	\$ 4,081,559

#### 1. Square Footage Used As Cost Driver

Square footage was used as the cost driver to allocate costs for the following resources:

- \* Electricity
- \* Natural Gas

- \* Main Gas

- \* Custodial (Naval Postgraduate School)

- \* Grounds Maintenance (Naval Postgraduate School)

Square footage was selected as the cost driver to allocate electricity, natural gas, and main gas costs since the size of building structures is a primary driver of the usage of these resources. Allocations, rather than tracing these costs directly to support activities and cost objects, are required since the majority of the buildings are not metered.

Some subsidies do exist when using square footage to allocate electricity. For example, the wind tunnel uses more electricity than does a medium size auditorium containing approximately the same square footage. Another example would be the allocation of electricity costs to vacant spaces. However, until all buildings are metered, allocating electricity costs using square footage provides a reasonable estimate. Allocations based on square footage are currently used by Public Works Department to allocate electricity, natural gas, and main gas costs to tenant commands for reimbursement (Tedrow, 1997).

Square footage was also selected as the cost driver to allocate custodial and ground maintenance at Naval Postgraduate School and Naval Support Activity, Monterey Bay. Custodial services consist of cleaning classrooms and offices, common areas, and rest rooms (Clark, 1997). Since custodial costs are based on the amount of area requiring custodial services, square footage was selected as the cost driver. The costs of these services were allocated based on the square footage each activity occupied or was assigned. Vacant spaces assigned to activities are included.

Square footage was also selected as the cost driver for grounds maintenance at Naval Postgraduate School and Naval Support Activity, Monterey Bay. Grounds maintenance includes the routine upkeep of the base grounds. The grounds maintenance contract results in equal monthly charges for ground maintenance services (Cantrell, 1997). Difficulty arises when attempting to identify which activity benefits from specific services. Therefore, since all activities benefit from ground maintenance services, and the cost of these services are based on the amount of area serviced, the costs were allocated based on the square footage each activity occupied and/or was assigned.

The use of square footage as an allocation base could generate misleading information if the amount of unassigned or vacant space increases. For instance, some costs (e.g., grounds maintenance) is not likely to vary with the amount of unassigned space. However, an increase in vacant spaces, assigned or unassigned, may create a subsidy for heavy users for costs such as electricity.

## **2. Number of Students Supported Used As Cost Driver**

The number of students supported was used as the cost driver for the following supply boxes:

- \* Custodial (La Mesa)
- \* Grounds Maintenance (La Mesa)

The number of students (i.e., average annual number of students in Management and Security Studies, Engineering and Computational Sciences, and Operational and Applied Science) was selected as the cost driver for custodial and ground maintenance services at La

Mesa housing since La Mesa housing exists solely to support this particular group of individuals.

**3. Number of Total Personnel Supported Used As Cost Driver**

The number of total personnel supported was used as the cost driver to allocate overhead costs for the following supply boxes:

- \* Water
- \* Sewage
- \* Refuse

The number of total personnel supported (i.e., all civilian and military personnel including the average number of students on board for the year, and tenant command personnel) was selected as the cost driver to allocate costs since people consume water and produce sewage and refuse. Allocations based on number of personnel are currently used by Public Works Department to allocate water costs to tenant commands for reimbursement (Tedrow, 1997).

**4. Number of Phone Lines Used As Cost Driver**

The number of phone lines was selected as the cost driver to allocate phone usage costs since phone usage costs were not identified to specific activities generating the phone usage costs. Total phone usage costs were divided equally by the total number of phone lines, resulting in phone usage costs being allocated to activities based on the number of phone lines assigned. The number of phone lines assigned to each activity is shown in Appendix M. Beginning in Fiscal Year 1997, phone usage costs are being identified to specific activities by the Supply Department (Pederaza, 1997).



#### D. SUMMARY BOXES

Summary boxes were used in this model to accumulate the cost of resources, support activities, and cost objects. The thirty-seven summary boxes (which include cost allocation factors) used in this model are shown in Appendix N. The direct costs of the support activities and the cost drivers for the allocations used in the model are presented below:

Support Activities	Costs	Cost Driver
* Environmental	\$ 239,731	Square Footage
* Public Works Department	7,257,729	Square Footage
* Naval Support Activity	3,768,170	Number of Personnel Supported
* Human Resources Office	761,673	Number of Civilian Personnel Supported
* Comptroller	930,694	Number of Accounts Tracked
* Time-Keeping (Payroll)	164,240	Number of Personnel Supported
* Computer Information Services	3,645,912	Number of Personnel Supported
* Morale, Welfare and Recreation	903,144	Number of Personnel Supported
* Police Department	657,616	Number of Personnel Assigned to Activities In Patrolled Areas
* Fire Department	859,659	Square Footage
* Supply Department	1,987,403	Number of Personnel Supported

* Superintendent	1,326,812	Percent of Time Spent On Specific Activities
* Provost	1,805,222	Percent of Time Spent On Specific Activities
* Dudley Knox Library	2,320,899	Percent of Use
* Dean of Students	1,820,347	Number of Students Supervised
* Total	\$ 28,449,251	

### **1. Environmental**

Square footage was selected as the cost driver to allocate environmental costs. All activities benefit from the actions of the three individuals performing environmental functions in the Public Works Department. Even though some activities may benefit more than others (e.g., Operational and Applied Science labs are likely to require more Environmental services than Management and Security Studies labs), all activities were assumed to benefit equally for the purposes of allocating costs. Since the cost of these services are driven by the amount of area serviced, the costs were allocated based on the square footage each activity occupied or was assigned.

### **2. Public Works Department**

Public Works Department provides services and performs maintenance actions for all Naval Postgraduate School and Naval Support Activity, Monterey Bay activities (Chase, 1997). Square footage was selected as the cost driver to allocate Public Works Department costs since prior to the beginning of Fiscal Year 1997, Public Works Department did not identify costs to specific support activities and cost objects (King, 1997). The weakness in

using square footage as the cost driver is that some support activities and cost objects use Public Work Department services more than others (e.g., Herrmann Hall requires more routine maintenance than does Glasgow Hall due to the age differences of the two buildings). All activities were assumed to benefit equally from the maintenance actions and services provided by Public Works Department. Based on this assumption, Public Works Department costs were allocated based on the square footage each activity occupied or was assigned.

### **3. Naval Support Activity, Monterey Bay**

The number of total personnel supported (i.e., all civilian and military personnel including average number of students on board for the year, and tenant command personnel) was selected as the cost driver to allocate Naval Support Activity, Monterey Bay costs. Naval Support Activity, Monterey Bay consists of several support activities performing various functions (e.g., legal, chaplain, food service) which support both mission and non-mission activities. Some large support activities which perform the same general functions (i.e., Environmental, Public Works Department, Supply Department, Police Department, Fire Department, and Morale, Welfare and Recreation) were taken out of the Naval Support Activity, Monterey Bay costs and treated as separate activities for the purpose of this thesis. The number of total personnel supported was selected as the cost driver since Naval Support Activity, Monterey Bay exists to support personnel performing both mission and non-mission activities.

#### **4. Human Resources Office**

The number of total civilian personnel supported was selected as the cost driver to allocate Human Resources Office costs. The number of total civilian personnel supported includes all civilian personnel supported by the Human Resources Office. The number of civilian personnel supported includes civilian personnel assigned to Naval Postgraduate School, Naval Support Activity, Monterey Bay, and the 174 civilian personnel assigned to Fleet Numerical Command (Reilly, 1997). The number of total civilian personnel supported was selected as the cost driver since the Human Resources Office exists to support the needs of the above mentioned civilian personnel.

#### **5. Comptroller**

The comptroller office is responsible for the administration of Naval Postgraduate School and Naval Support Activity, Monterey Bay appropriated funds. The number of accounts tracked was selected as the cost driver to allocate comptroller costs. The number of accounting transactions generated as a cost driver would have been a better cost driver for allocating comptroller costs. However, this cost driver was not selected due to the time required to determine the number of entries identified to specific activities.

#### **6. Timekeeping (Payroll)**

The number of total personnel supported was also selected as the cost driver to allocate timekeeping (i.e., payroll) function costs. The number of total personnel supported includes all civilian personnel assigned to Naval Postgraduate School and Naval Support Activity, Monterey Bay (Reilly, 1997). Civilian personnel assigned to tenant commands are

not included. The number of total personnel supported was selected as the cost driver since the timekeeping functions exist to support the needs of both mission and non-mission activity personnel.

#### **7. Computer Information Services**

Computer Information Services provides the computer support services for the Naval Postgraduate School, Naval Support Activity, Monterey Bay, and tenant commands (Roy, 1997). Identifying direct computer information services costs generated by individual personnel usage and identifying those costs to specific activities would not be practical in this thesis due to time constraints. Therefore, the number of total personnel supported was selected as the cost driver to allocate Computer Information Services costs. The number of total personnel supported includes all civilian and military personnel at the Naval Postgraduate School and Naval Support Activity, Monterey Bay, the average number of students on board for the year, and all tenant command personnel. The number of total personnel supported was selected as the cost driver since students, faculty, staff, and tenant command personnel all benefit from the support and services provided by Computer Information Services.

#### **8. Morale, Welfare and Recreation**

The number of total personnel supported was selected as the cost driver to allocate Morale, Welfare and Recreation (MWR) costs. The number of total personnel supported includes all civilian and military personnel at the Naval Postgraduate School and Naval Support Activity, Monterey Bay, the average number of students on board for the year, and all tenant command personnel. Since the exact number and category (e.g., military, civilian, retiree, dependent, guests) of users is unknown, allocating MWR costs to specific activities

based on actual usage was not possible. Therefore, the number of total personnel supported was selected as the cost driver since those individuals supported are afforded an equal opportunity to benefit from MWR services and the use of MWR facilities.

#### **9. Police Department**

The number of total personnel assigned to the activities (e.g., Management and Security Studies) or areas patrolled (e.g., La Mesa Housing) by base police was selected as the cost driver to allocate Police Department costs. One-half of the Police Department costs were assigned to each of the two shifts.

The allocation of the 0600-1800 shift costs were based on the estimate of police patrolling La Mesa housing 50 percent of the time, Naval Postgraduate School and Naval Support Activity, Monterey Bay 30 percent of the time, and off-base MWR locations 20 percent of the time (Calvey, 1997). The total number of students (i.e., the average annual number of students in Management and Security Studies, Engineering and Computational Sciences, and Operational and Applied Science) was selected as the cost driver for the estimate of 50 percent of the time patrolling La Mesa housing since students from these activities live in La Mesa housing. An assumption was made that the distribution of students living in La Mesa housing is the same as the distribution of students in the three academic areas. Additionally, the total number of personnel (i.e., all civilian and military personnel at the Naval Postgraduate School and Naval Support Activity, Monterey Bay, the average number of students on board for the year, and all tenant command personnel) was selected

as the cost driver for the estimate of 30 percent of the time patrolling Naval Postgraduate School and Naval Support Activity, Monterey Bay, and the 20 percent of the time patrolling off-base MWR locations since these personnel benefit from Police Department patrols.

The allocation of the 1800-0600 shift costs was based on the estimate of police patrolling academic buildings 60 percent of the time, La Mesa housing 30 percent of the time, and the remainder of Naval Postgraduate School, Naval al Support Activity, Monterey Bay, and off-base MWR locations 10 percent of the time (Calvey, 1997). The total number of Management and Security Studies, Engineering and Computational Sciences, and Operational and Applied Science personnel (i.e., all civilian personnel and average number of students on board for the year) was selected as the cost driver for the estimate of 60 percent of the time patrolling academic buildings since these personnel benefit for Police Department patrols. The average annual number of students was selected as the cost driver for the estimate of 30 percent of the time patrolling La Mesa housing. Finally, the total number of personnel (i.e., all civilian and military personnel at the Naval Postgraduate School and Naval Support Activity, Monterey Bay, the average number of students on board for the year, and all tenant command personnel) was selected as the cost driver for the estimate of 10 percent of the time patrolling the remainder of Naval Postgraduate School, Naval Support Activity, Monterey Bay, and off-base MWR locations since these personnel benefit from Police Department patrols.

## **10. Fire Department**

Square footage was selected as the cost driver to allocate Fire Department costs. The Fire Department spends the majority of time performing on-base fire prevention functions (Nutt, 1997). Therefore, square footage was selected as the cost driver since the amount of time spent by Fire Department personnel performing fire prevention functions was proportionate to the square footage each activity occupied and/or was assigned.

## **11. Supply Department**

The number of total personnel supported was selected as the cost driver to allocate Supply Department costs. The number of personnel supported includes military and civilian faculty and staff. In addition to tracking copier, postal, and FEDEX/UPS costs (Phillis, 1997), the Supply Department provides supply logistics functions for all activities. Since Supply Department support for tenant commands is minimal (Allen, 1997), only Naval Postgraduate School and Naval Support Activity, Monterey Bay activities were included in the calculation. The number of requisitions processed would probably be a better cost driver. However, the data needed to track the number of purchase requisitions processed for support activities and cost objects was not available. The number of total personnel supported was selected as the cost driver since all mission and non-mission activities benefit from the service functions provided by the Supply Department.

## **12. Superintendent**

The percentage of time spent by the Superintendent on specific activities was selected as the cost driver to allocate the costs of the Superintendent and her staff. The Superintendent of the Naval Postgraduate School is a Navy flag officer of the line and has



command responsibility for accomplishment of the school's mission. In addition to serving as the institution's president, the Superintendent is the academic coordinator for all graduate education programs in the Navy (Calhoon, 1997). The Superintendent also oversees the activities of Commander, Naval Support Activity, Monterey Bay (Grahman, 1997).

The allocation of costs based on the percentage of time allocated to the Superintendent's activities was obtained by interviewing her Executive Assistant. Since the functions of the Superintendent's staff are driven by her activities (Grahman, 1997), the allocation of Superintendent costs and the costs of her staff were assumed to be the same, even though her staff may relieve the need for her to spend time on certain activities. Therefore, eighty-five percent of Superintendent costs were allocated to mission related activities, five percent were allocated to Naval Support Activity, Monterey Bay, five percent were allocated to the Director of Resource Management, and the final five percent were allocated exclusively to non-mission activities (Grahman, 1997).

### **13. Provost**

The percentage of time spent by the Provost on specific activities was selected as the cost driver to allocate the costs of the Provost and his staff. The Provost is the Superintendent's principle assistant who is the ranking member of the civilian faculty. He is the chief educational officer and is responsible to the Superintendent for all academic matters (Calhoon, 1997).

The allocation of costs based on the percentage of time allocated to the Provost's activities was obtained by interviewing his Academic Services Manager. Since the functions of the Provost's staff are driven by his activities, the allocation of Provost costs and the costs

of his staff were assumed to be the same, even though his staff may relieve the need for him to spend time on certain activities. Therefore, eighty-five percent of the total overhead costs were evenly allocated among the three academic areas (i.e., Management and Security Studies, Engineering and Computational Sciences, and Operational and Applied Science), five percent were allocated to the Research Department, five percent were allocated to Computer and Information Services, and five percent were allocated to the Dudley Knox Library (Paulsen, 1997).

#### **14. Dudley Knox Library**

The cost driver selected to allocate Dudley Knox Library costs was the percent of use by individuals. The Dudley Knox Library is a university library which is dedicated both to supporting research and graduate-level education and providing for the special requirements of the Naval Postgraduate School (Calhoun, 1997). In addition to Naval Postgraduate School students and faculty, students from local community colleges, regional universities, and local area high schools use library resources. Additionally, the Dudley Knox Library is open to the general public to review Federal Government documents on file (McCrave, 1997).

Since no records are kept indicating who actually uses library resources, the percent of use by various individuals was estimated by a career librarian. An estimate was obtained which indicated that seventy-five percent of the individuals using the library were either Naval Postgraduate School students or staff (McCrave, 1997). Therefore, seventy-five percent of library costs were allocated to the three academic areas based on the number of faculty and average annual number of students assigned to the three academic areas. The remaining twenty-five percent of library costs were allocated to non-mission activities.

## **15. Dean of Students**

The number of students supervised was selected as the cost driver to allocate the Dean of Students costs. The number of students supervised includes the average number of Management and Security Studies, Engineering and Computational Sciences, and Operational and Applied Science students by quarter. The Dean of students is responsible for the administration of military personnel in the three academic areas (Lewis, 1997). Since the number of students in each academic area varied each quarter, different allocation percentages were assigned each quarter based on the average number of students enrolled in each of the three academic areas.



#### IV. RESULTS OF THE NAVAL POSTGRADUATE SCHOOL ACTIVITY-BASED COSTING MODEL

This chapter provides the results of the activity-based costing model developed for the Naval Postgraduate School. The Management and Security Studies, Engineering and Computational Sciences, Operational and Applied Sciences, Research Department, School of Aviation Safety, and Residual Costs output boxes are discussed and analyzed. The financial results for Fiscal Year 1996 are shown in Appendix O. The first page of Appendix O is the annual financial results for the Naval Postgraduate School. The next four pages are the quarterly financial results for the Naval Postgraduate School. The next five pages are the annual financial results for the five cost objects. The final page contains residual costs. A summary of the costs traced to the cost objects, the indirect mission support costs allocated to the cost objects, and the total costs for the five cost objects is presented below:

Cost Object	Costs Traced To the Cost Objects	Indirect Mission Support Costs Allocated to the Cost Objects	Total Cost
* Management and Security Studies	\$ 2,304,257	\$ 7,699,332	\$ 10,003,589
* Engineering and Computational Sciences	6,270,215	10,134,497	16,404,712
* Operational and Applied Science	5,103,595	9,372,231	14,475,826
* Research Department	565,382	625,649	1,191,031
* School of Aviation Safety	231,180	1,061,970	1,293,150

A summary of the total costs, cost per student, and cost per total number of personnel supported for cost objects is presented below:

Cost Object	Total Cost	Cost/Student	Cost/Total Number of Personnel Supported
* Management and Security Studies	\$10,003,589	\$ 17,612	\$ 15,273
* Engineering and Computational Sciences	16,404,712	46,604	31,608
* Operational and Applied Science	14,475,826	28,384	22,443
* Research Department	1,191,031	N/A	N/A
* School of Aviation Safety	1,293,150	8,452	N/A

**A. MANAGEMENT AND SECURITY STUDIES OUTPUT BOX**

The Fiscal Year 1996 quarterly financial results for Management and Security Studies is shown in Appendix P. Total costs of Systems and Security Studies for FY 96 totaled \$ 10,003,589, which was the lowest total of the three major academic areas. Additionally, Management and Security Studies had the lowest cost per student at \$ 17,612. Finally, the cost per all Management and Security Studies personnel (i.e., includes faculty, staff, and average number of students on board for the year) was the lowest at \$ 15,273.

**B. ENGINEERING AND COMPUTATIONAL SCIENCES OUTPUT BOX**

The Fiscal Year 1996 quarterly financial results for Engineering and Computational Sciences is shown in Appendix Q. Total costs of Engineering and Computational Sciences for FY 96 totaled \$ 16,404,712, which was the highest total of the three major academic

areas. Additionally, Engineering and Computational Sciences had the highest cost per student at \$ 46,604. Finally, the cost per all Engineering and Computational Sciences personnel was the highest at \$ 31,608.

**C. OPERATIONAL AND APPLIED SCIENCES OUTPUT BOX**

The Fiscal Year 1996 quarterly financial results for Operational and Applied Science is shown in Appendix R. Total costs of Operational and Applied Science for FY 96 totaled \$ 14,475,826, which was the second highest total of the three major academic areas. Additionally, Operational and Applied Science had the second highest cost per student at \$ 28,384. Finally, the cost per all Operational and Applied Science personnel was the second highest at \$ 22,443.

**D. RESEARCH DEPARTMENT OUTPUT BOX**

The Fiscal Year 1996 quarterly financial results for the Research Department is shown in Appendix S. Total costs of Research Department for FY 96 totaled \$ 1,191,031. Since the Research Department coordinates faculty research in addition to overseeing thesis processing (Kuska, 1997), a cost per student would not be very meaningful.

**E. SCHOOL OF AVIATION SAFETY OUTPUT BOX**

The Fiscal Year 1996 quarterly financial results for the School of Aviation Safety is shown in Appendix T. Total costs of the School of Aviation Safety for FY 96 totaled \$ 1,293,150. Based on an average student load for the year of 153 students, the cost per student was \$ 8,452.

**F. RESIDUAL COSTS BOX**

The Fiscal Year 1996 quarterly financial results for indirect costs allocated to the residual costs box is shown in Appendix U. The residual costs that flowed into this box represent the accumulation of Naval Postgraduate School and Naval Support Activity, Monterey Bay costs that did not flow into the five mission demand boxes. Since NetProphet requires all costs to be allocated, a cost object (i.e., residual costs demand box) was inserted into the model. Therefore, the total indirect costs in this box (i.e., \$ 3,637,132) do not include all of the costs for the tenant commands since only a partial allocation of costs generated by tenant commands were considered in this model.



## **V. CONCLUSIONS AND RECOMMENDATIONS**

### **A. CONCLUSIONS**

The objective of this thesis was to develop an activity-based costing model for indirect costs at the Naval Postgraduate School designed primarily for Naval Postgraduate School administrators and managers to evaluate the cost-flows and allocation of indirect costs using activity-based costing. The primary research question addressed in this thesis is what are the cost drivers and associated cost flows for resources and support activities at the Naval Postgraduate School?

#### **1. Identification of Cost Drivers and Cost Flows**

This thesis identified cost drivers and associated cost flows for resources and support activities at the Naval Postgraduate School and Naval Support Activity, Monterey Bay for Fiscal Year 1996. Archival research and unstructured interviews were used to determine the cost drivers and associated cost flows of resources and support activities.

#### **2. Developing a Computer-Based Activity-Based Costing Model**

This thesis has demonstrated the ability to model the indirect cost flows at the Naval Postgraduate School. All allocations are imprecise. However, the model developed in this thesis provides Naval Postgraduate School administrators and management an estimate of indirect costs for mission activities.

Once cost drivers and associated cost flows for resources and support activities were identified, a computer-based activity-based costing model was developed using Sapling's NetProphet software. The output data produced by the model can assist Naval Postgraduate

School administrators and managers to evaluate the cost-flows and allocation of indirect costs.

## **B. RECOMMENDATIONS**

### **1. Costs**

Due to the scope of this thesis, an analysis of each cost figure (e.g., all Management and Security Studies OPTAR expenditures) was not practical. Therefore, an assumption was made that the cost data obtained from source documentation was accurate. Additional research is recommended to evaluate the accuracy of all cost figures.

### **2. Cost Reimbursement**

There are situations where costs are not subsequently reimbursed to either the Naval Postgraduate School or Naval Support Activity, Monterey Bay. For instance, the Naval Support Activity, Monterey Bay does not charge on-base tenant commands for either Police or Fire Department protection services (Moore, 1997). Additional research is recommended to determine if additional costs (e.g., utilities and office equipment used in conjunction with research projects, non-reimbursed services provided by support activities) should be considered for reimbursement. Additional research is also recommended to validate the rates for those costs that are reimbursed (e.g., electricity).

### **3. Tenant Commands**

The costs of the tenant commands that were associated with activities supporting either the Naval Postgraduate School and/or Naval Support Activity, Monterey Bay (e.g., Personnel Support Detachment, Regional Officer in Charge of Construction, Dental Command), were not allocated due to the time required to identify and determine indirect cost

allocations. For example, the Regional Officer in Charge of Construction negotiates and administers several maintenance and service contracts (e.g., grounds maintenance and custodial services) that benefit the Naval Postgraduate School. Since these allocations were beyond the scope of this thesis, additional research is recommended to determine allocations of these costs to Naval Postgraduate School and Naval Support Activity, Monterey Bay support activities.

#### **4. Military Instructor Research**

Costs associated with military personnel conducting reimbursable research were not included in this model since most military instructors are used only for classroom instruction. To improve the accuracy of the model, additional research is recommended to identify and allocate the costs associated with military instructors conducting research.

#### **5. Square Footage**

Square footage figures used in this thesis were an approximation for assigned square footage since some of the data provided square footage totals by building number and other data provided interior classroom square footage. Since this did not provide an exact calculation of the square footage assigned to support activities and cost objects, additional research is recommended to determine exact square footage figures.

#### **6. Environmental**

Environmental costs were allocated based on the square footage each activity occupied or was assigned, even though the environmental costs may be more a function of how space is used. Additional research is recommended to identify specific functions of environmental personnel to specific activities to improve the accuracy of the model.

## **7. Public Works Department**

Since Public Works Department did not identify costs to specific activities prior to the beginning of Fiscal Year 1997, costs were allocated based on the square footage each activity occupied and/or was assigned. Additional research is recommended to identify Public Works Department costs to specific activities as direct vice allocated costs.

## **8. Comptroller**

The number of accounts tracked was selected as the cost driver to allocate comptroller costs. However, the number of accounting transactions generated would have been a better cost driver for allocating comptroller costs. Additional research is recommended to determine the number of accounting transactions generated by specific mission and non-mission activities.

## **9. Computer Information Services**

The number of total personnel supported was selected as the cost driver to allocate Computer Information Services costs since identifying direct computer information services costs generated by specific usage and identifying those costs to specific activities was not practicle during this thesis research. Additional research is recommended to determine costs generated by specific usage and identifying those costs to specific activities.

## **10. Supply Department**

The number of total personnel supported was selected as the cost driver to allocate Supply Department costs. However, the number and complexity of requisitions processed would probably be a better cost driver for allocating Supply Department costs. Archival research is recommended to determine the number and complexity of requisitions identified

to specific activities. Also, since Supply Department does provide some support for tenant commands, additional research is recommended to determine the cost of Supply Department support provided to tenant commands.

**11. Morale, Welfare and Recreation and Dudley Knox Library**

Individuals, in addition to Naval Postgraduate School students and faculty, use the Dudley Knox Library and Morale, Welfare and Recreation facilities. Since the exact number and category (e.g., military, civilian, retiree, dependent, guests) of users is unknown, additional research is recommended to determine the users of these support activities.

**12. Superintendent and Provost**

The percentage of time spent by the Superintendent and Provost on specific activities was selected as the cost driver to allocate the costs of the Superintendent, Provost, and their respective staffs. However, their respective staffs may relieve the need for the superintendent and Provost to spend time on certain activities. Additional research is recommended to better estimate Superintendent and Provost cost allocations.

**13. Cost Drivers**

The selection of cost drivers is not a totally objective process. In some cases, less than optimal cost drivers were selected for reasons cited in the thesis. Therefore, the following list of alternative cost drivers and cost allocation methods recommended for further research is provided which might improve the overall accuracy of the model:

Activity	Current Cost Driver	Alternative Cost Driver
* Environmental	Square Footage	Percent of Time Spent
* Public Works Department	Square Footage	Direct Costing

* Comptroller	Number of Personnel Supported	Number of Accounting Transactions
* Computer Information Services	Number of Personnel Supported	Percent of Usage
* Supply Department	Number of Personnel Supported	Number and Complexity of Requisitions
* Superintendent and Provost	Percent of Superintendent's and Provost's Time Spent Performing Activities	Percent of Time All Office Personnel Spent Performing Activities

Although each of the recommended cost drivers would be an improvement over those used in the thesis, each of the recommended drivers could be refined to produce even better cost estimates. The selection of the cost driver used should be based on the costs and benefits of the resulting information.

**C. REMARKS**

This thesis has provided the Naval Postgraduate School and Naval Support Activity, Monterey Bay management and administrators with a tool for reviewing and possibly reducing indirect costs. Since this thesis has provided an estimate vice exact cost figures, further research in recommended areas should be pursued. Additional areas of study may yield valuable information which might be used to generate significant cost savings by exposing wasted and/or the inefficient use of the Naval Postgraduate School and Naval Support Activity, Monterey Bay scarce resources.







## LIST OF REFERENCES

- Allen, Gregory, Assistant Supply Officer at Naval Support Activity, Monterey Bay; Interview with the author on 24 April 1997.
- Atkinson, Banker, *Management Accounting*, Prentice Hall, Upper Saddle River, 1997.
- Belgum, Stephen A., *Activity-Based Costing at the Naval Postgraduate School*, Naval Postgraduate School, March 1995.
- Buckley, J. W., Buckley, M. H., *Research Methodology and Business Decisions*, National Association of Accountants, Montvale, 1976.
- Burke, Barbara, Supervisory Support Services Specialist in the Academic Planning Office of the Naval Postgraduate School; Interview with the author on 12 February 1997.
- Calhoon, Theodore, *Naval Postgraduate School Academic Year 1997*, Monterey, CA, 1997.
- Calvey, William, Police Department Chief for Naval Support Activity, Monterey Bay; Interview with the author on 1 April 1997.
- Cantrell, Kim, Contract Specialist, Resident Officer in Charge of Construction, Naval Facilities Engineering Command; Interview with the author on 9 April 1997.
- Chase, CDR, CEC, USN, Public Works Officer for Naval Support Activity, Monterey Bay; Interview with the author on 5 March 1997 and 15 April 1997.
- Clark, Sheila, Contract Branch Manager, Resident Officer in Charge of Construction, Naval Facilities Engineering Command; Interview with the author on 9 April 1997.
- Deakin, Maher, *Cost Accounting*, Richard D. Irwin, Inc., 1994.
- Defense Finance and Accounting Service, *FY 97 Navy and Marine Corps Composite Standard Rates*, Cleveland, OH, 1996.
- Dominiak, Louderback, *Managerial Accounting*, South-Western Publishing Co., Cincinnati, 1994.
- Elster, Richard, Provost for Naval Postgraduate School; Interview with the author on 20 November 1996.

Flinders, Gordon D., Transportation Supervisor, Public Works Department, Naval Support Activity, Monterey Bay; Interview with the author on 8 April 1997.

Forrester, Yolando, Assistant Director of Fiscal Operations at Naval Support Activity, Monterey Bay; Interview with the author on 11 February 1997.

Grahlman, Richard B., CDR, USN, Executive Assistant to the Superintendent, Naval Postgraduate School; Interview with the author on 9 April 1997.

Gray, James, YNC (SS), USN, Administrative Services Chief of Naval Support Activity, Monterey Bay; Interview with the author on 12 February 1997.

Hodge, Eldred, DKCS(SW), USN, Deputy Disbursing Officer, Personnel Support Detachment; Interview with the author on 12 February 1997.

Howard, Gil, Director of Academic Planning for the Naval Postgraduate School; Interview with the author on 20 November 1996, 10 February 1997, 11 April 1997, and 21 April 1997.

Jay, Robert, Comptroller (Acting) of Naval Support Activity, Monterey Bay; Interview with the author on 24 January 1997.

King, Barbara, Fiscal Analyst Supervisor for Naval Support Activity, Monterey Bay; Interview with the author on 13 January 1997 and 15 April 1997.

Kuska, Danielle, Research Programs Supervisor at Naval Postgraduate School; Interview with the author on 15 April 1997.

Labuguen, DSC, USN, Division Officer for Academic Division for Naval Support Activity, Monterey Bay; Interview with the author on 12 February 1997.

Lewis, Johanne C., LCDR, USN, Assistant Director of Programs for the Naval Postgraduate School; Interview with the author on 12 February 1997, 19 March 1997, and 31 March 1997.

Linser, Shirley, Supply Department Supervisory Contract Specialist for Naval Support Activity, Monterey Bay; Interview with the author on 2 April 1997.

McCrave, Kate, Assistant Reader Services Librarian, Naval Postgraduate School; Interview with the author on 10 April 97.

Meyer, Mary J., Commander, Naval Support Activity, Monterey Bay; Interview with the author on 5 March 1997.

Moore, Kathi, Director of Fiscal Operations at Naval Support Activity, Monterey Bay; Interview with the author on 24 April 1997.

Nutt, R. G., Fire Department Chief for Naval Support Activity, Monterey Bay; Interview with the author on 31 March 1997.

Paulsen, Patricia, Academic Services Manager to the Provost of Naval Postgraduate School; Interview with the author on 4 April 1997.

Pederaza, A., Supply Material Division Officer for Naval Support Activity, Monterey Bay; Interview with the author on 22 April 1997.

Phillis, Michael, LT, SC, USN, Supply Department Control Division Officer for Naval Support Activity, Monterey Bay; Interview with the author on 2 April 1997, 4 April 1997, and 8 April 1997.

Reilly, Megan, Deputy Comptroller of Naval Postgraduate School; Interview with the author on 24 January 1997, 11 February 1997, 26 February 1997, 4 April 1997, and 16 April 1997.

Roy, Ruth, Computer and Information Services Support for Naval Postgraduate School; Interview with the author on 15 April 1997.

Sapling Corporation, *Getting Started*, Mississauga, Ontario, Canada, 1996.

Sapling Corporation, *NetProphet - New User Workshop Manual*, Mississauga, Ontario, Canada, 1996.

Stalh, Toby, Director of Training for Sapling Corporation; Interview with the author on 16 December 1996 and 18 December 1996.

Schmidt, Steven D., LT, USN, Assistant Public Works Officer for Naval Support Activity, Monterey Bay; Interview with the author on 13 January 1997 and 1 April 1997.

Smith, Karen, Education Technician for School of Aviation Safety at Naval Postgraduate School; Interview with the author on 17 March 1997.

Tedrow, David, Public Works Engineering Director for Naval Support Activity, Monterey Bay; Interview with the author on 31 March 1997 and 10 April 1997.

Tufts, Robert K., *Activity-Based Costing in the Systems Management Department*, Naval Postgraduate School, December 1995

Waddell, George, Advanced User Workshop Training Instructor for Sapling Corporation;  
Interview with the author on 17 December 1996.

## APPENDIX A. ACADEMIC AREAS

This appendix provides a listing of the eleven Academic Departments and five Academic Groups. Academic Groups are identified by a number sign (#).

### **Management and Security Studies**

- \* Systems Management
- \* National Security Affairs

### **Engineering and Computational Sciences**

- \* Aeronautics and Astronautics
- \* Computer Science
- \* Electrical and Computer Engineering
- \* Mathematics
- \* Mechanical Engineering

### **Operational and Applied Sciences**

- \* Oceanography
- \* Operations Research
- \* Meteorology
- \* Physics
- \* Undersea Warfare #
- \* Space Systems #
- \* Information Warfare #
- \* Command, Control and Communications #





ACTIVITY	Q1	Q2	Q3	Q4	TOTAL
Superintendent					
Comand Eval	170	170	2640	230	3,210
JAG	4748	4748	24	1949	11,468
Patent Atny	0	0	2760	2163	4,923
EEO	2,554	2,554	3,511	525	9,143
Safety	3,151	3,151	2,413	1,207	9,921
Safety Shoes	1,139	1,139	1,273	1,005	4,556
Safety Glasses	3,761	3,761	4,419	3,407	15,347
Superintendent	7,067	7,067	6,519	17,858	38,510
TQL	3,598	3,598	3,430	19,659	30,284
Reinvention Lab	0	0	1,693	193	1,886
Marketing	0	0	0	6,417	6,417
FAM Trip	0	0	950	818	1,768
Electron M-scope	0	0	13,734	0	13,734
Postal Costs	272	405	414	544	1,636
FEDEX/UPS	137	137	137	137	549
Printing	4,625	4,625	4,625	4,625	18,500
Copier Expense	1,491	1,491	1,491	1,491	5,963
Safety TVL	933	933	-185	0	1,680
JAG TVL	355	355	-353	922	1,279
Patent Atny TVL	596	596	0	0	1,191
EEO TVL	2,013	2,013	-48	836	4,814
Superint. TVL	12,718	12,718	28,289	16,143	69,868
TQL TVL	2,110	2,110	314	0	4,534
Reinvent Lab TVL	1,921	1,921	1,163	360	5,364
Marketing TVL	0	0	9,877	(1,027)	8,850
FAM Trip TVL	0	0	138	0	138
CIV Staff (00)	10,177	10,433	10,433	10,558	41,600
CIV Staff (00-Q)	35,920	36,823	36,823	37,267	146,833
CIV Staff (003)	26,680	27,351	27,351	27,680	109,060
CIV Staff (006)	8,999	9,226	9,226	9,337	36,787
STAFF ENL					
(1) E7	12,391	12,391	12,391	12,391	49,562
(1) E6	10,709	10,709	10,709	10,709	42,824
STAFF OFF					
(1) O8	35,716	35,716	35,716	35,716	142,863
(1) O6	29,625	29,625	29,625	29,625	118,498
(2) O5	51,232	51,232	51,232	51,232	204,926
(1) O4	21,496	21,496	21,496	21,496	85,983
(1) O3	18,086	18,086	18,086	18,086	72,343
TOTAL	314,390	316,580	352,316	343,559	1,326,812



ACTIVITY	Q1	Q2	Q3	Q4	TOTAL
Provost					
Provost	32,836	32,836	16,883	3,211	85,769
FAC PCS	15,780	15,780	3,224	18,835	53,619
Assoc Provost Ins	12,790	12,790	40,523	21,283	87,385
Audio Visual	20,722	20,722	9,341	413	51,197
Printing	2,250	2,250	0	(4,500)	0
PAO-Mission	14,820	14,820	2,194	4,000	35,834
Copier Expense	789	789	789	789	3,157
FEDEX/UPS	106	106	106	106	423
Postal Costs	1,034	1,407	1,833	1,932	6,206
Provost TVL	2,326	2,326	1,724	5,368	11,743
FAC PCS TVL	2,665	2,665	846	4,229	10,404
A. Provost Ins TVL	8,220	8,220	6,572	103	23,115
CIV STAFF 01	42,537	43,830	43,830	44,958	175,155
CIV STAFF 01B	197,637	209,655	219,276	220,227	846,795
CIV FAC	103,605	103,605	103,605	103,605	414,420
TOTAL	458,117	471,801	450,746	424,559	1,805,222
Compt/Payroll					
Comptroller	13,864	13,864	6099	5091	38,917
Staff PCS	1,550	350	0	0	1,900
Printing	750	750	750	750	3,000
Comptroller	4	4	1,330	1,142	2,479
Copier Expense	1,059	1,059	1,059	1,059	4,236
CIV STAFF	254,537	260,935	260,935	264,078	1,040,484
FEDEX/UPS	370	370	370	370	1,479
Postal Costs	493	783	701	462	2,439
TOTAL	272627	278115	271244	272952	1,094,934
TTL COMPT					930,694
TTL PAYROLL					164,240
Human Res. Off.					
Empl. Asst. Prog.	0	0	0	24,368	24,368
CIV PERS	15,779	15,779	12,290	7,332	51,179
Recog Store	6,729	6,729	3,865	2,364	19,686
Printing	625	625	625	625	2,500
Training	14,776	14,776	5,607	1,118	36,275
Copier Expense	570	570	570	570	2,279
FEDEX/UPS	1,565	1,565	1,565	1,565	6,275
Postal Costs	266	421	377	249	1,313
Training	115	115	578	-21	787
CIV STAFF	150,942	154,735	154,735	156,599	617,011
TOTAL	191367	195315	180212	194769	761,673

ACTIVITY	Q1	Q2	Q3	Q4	TOTAL
Dean of Students					
Dir Programs	4,840	4,840	11,435	4,121	25,236
Security Vault	5,694	5,694	2,304	3,121	16,813
Printing	11,250	11,250	11,250	11,250	45,000
Copier Expense	1,823	1,823	1,823	1,823	7,291
FEDEX/UPS	5	5	5	5	20
Postal Costs	1,619	2,003	1,634	3,952	9,208
DIR Progs. TVL	4,407	4,407	5,772	1,672	16,258
Med Students	9,073	9,073	17,830	7,438	43,414
CIV INST	0	0	1,074	1,423	2,497
CIV STAFF	230,856	240,739	251,654	262,702	985,951
STAFF OFF					
(1) 06	29,625	29,625	29,625	29,625	118,498
(1) 05	25,616	25,616	25,616	25,616	102,463
(1) 04	21,496	21,496	21,496	21,496	85,983
(5) 03	90,429	90,429	90,429	90,429	361,715
TOTAL	436,733	447,000	471,947	464,673	1,820,347
NAVSUPACT,MB					
Mil OPS	12,661	12,661	8,799	1,361	35,482
Admin	5,221	5,221	2,801	5,011	18,254
Base PCS	9,785	9,785	1,000	29,356	49,925
Mil OPS TVL	5,294	5,294	10,925	5,316	26,829
Base PCS TVL	2,309	2,309	0	5,707	10,325
Admin	92,195	94,512	94,512	95,651	376,869
Admin MIL STAFF					
(1) 06	29,625	29,625	29,625	29,625	118,498
(1) 05	25,616	25,616	25,616	25,616	102,463
(1) 03	18,086	18,086	18,086	18,086	72,343
(1) W3	16,128	16,128	16,128	16,128	64,511
(4) E7	49,563	49,563	49,563	49,563	198,252
(4) E5	35,807	35,807	35,807	35,807	143,228
(1) E4	7,380	7,380	7,380	7,380	29,520
Enlist. Dining Svc	38,720	38,720	30,975	61,952	170,367
Family SVCs	924	924	2,122	46	4,016
Security Mgr	1,156	1,156	719	3,664	6,694
Child Dev. Ctr	1,372	1,372	3,764	20,182	26,689
NSA Start-Up	0	0	0	12,785	12,785
Photo	87,344	87,344	4,481	(126,821)	52,348
Maint & Repair	9,179	9,179	4,509	783	23,649
Safety CIV	30,389	31,154	31,154	31,529	124,225
Fam Serv Ctr CIV	19,862	20,362	20,362	20,607	81,194
Child Dev. Ctr CIV	113,337	116,186	116,186	117,585	463,292

ACTIVITY	Q1	Q2	Q3	Q4	TOTAL
Food Svc MIL					
(1) E7	12,391	12,391	12,391	12,391	49,563
(2) E5	17,904	17,904	17,904	17,904	71,614
(2) E4	14,760	14,760	14,760	14,760	59,040
Bach. Off Qtrs	2,682	2,682	10,728	48,641	64,732
Chaplain	43,489	43,489	6,217	25,881	119,076
Mil Medical TVL	554	554	1,008	1,776	3,892
Chaplain CIV	7,274	7,457	7,457	7,547	29,734
Chaplain MIL					
(1) 06	29,625	29,625	29,625	29,625	118,498
(1) 04	21,496	21,496	21,496	21,496	85,983
(1) 03	18,086	18,086	18,086	18,086	72,343
(1) E6	10,709	10,709	10,709	10,709	42,834
(1) E3	6,337	6,337	6,337	6,337	25,346
Bach. Off Qtrs MIL					
(1) 03	18,086	18,086	18,086	18,086	72,343
(1) E8	14,303	14,303	14,303	14,303	57,210
(3) E6	32,126	32,126	32,126	32,126	128,502
(1) E5	8,952	8,952	8,952	8,952	35,807
(9) E4	66,420	66,420	66,420	66,420	265,680
(1) E3	6,337	6,337	6,337	6,337	25,346
(1) 05	25,616	25,616	25,616	25,616	102,463
PAO	2,864	2,864	3,732	13,014	22,474
PAO TVL	194	194	575	105	1,067
Student Moves	12,668	12,668	14,869	8,756	48,960
Printing	6,250	6,250	6,250	6,250	25,000
Copier Expense	3,806	3,806	3,806	3,806	15,222
Postal Costs	2,202	4,505	3,586	3,356	13,649
TOTAL	997,084	1,006,001	875,890	889,199	3,768,170
Computer Info Svc					
Office of Dean	4,584	4,584	33,999	23,806	66,972
Admin Cp SVCs	261,122	261,122	(92,512)	2,469	432,199
Netwkg Infra	53,090	53,090	(25,096)	50,047	131,131
DFR Support	35,162	35,162	18,254	9,602	98,179
Acad Cp SVCs	71,293	71,293	23,086	32,423	198,094
NEB LAN	0	0	191,158	309,000	500,958
COM-ADP	0	0	0	140,000	140,000
Server	0	0	46,358	0	46,358
Printing	2,500	2,500	2,500	2,500	10,000
Copier Expense	708	708	708	708	2,831
Postal Costs	18	95	126	7	247
Office of Dean TV	5,856	5,856	8,093	4,661	24,466
Admin Cp Svc TV	2,596	2,596	0	0	5,192

ACTIVITY	Q1	Q2	Q3	Q4	TOTAL
Netwk/Infra TVL	2,076	2,076	-120	(1,087)	2,945
DFR Support TVL	1,631	1,631	0	0	3,261
C IV STAFF	539,019	416,445	344,005	387,144	1,686,613
CIV FAC	138,140	138,140	138,140	138,140	138,140
MIL STAFF					
(1) O4	21,496	21,496	21,496	21,496	85,983
(1) O3	18,086	18,086	18,086	18,086	72,343
TOTAL	1,157,377	1,034,880	728,281	1,139,002	3,645,912

Mgmt & Sec S.					
Systems Mgmt	25,322	25,322	26,826	42,044	119,513
Natl Sec Affairs	13,700	13,700	17,721	7,956	53,077
Conrad Chair	0	0	1,296	69,462	70,758
Dean of Mgmt	16,384	16,384	0	(1,976)	30,792
Base Mgmt	0	0	0	4,300	4,300
Student TxBks	43,686	41,747	37,740	46,767	169,940
Printing	9,750	9,750	9,750	9,750	39,000
Natl Sec & Intel	174	174	4,377	275	4,999
Copier Expense	9,926	9,926	9,926	9,926	39,704
FEDEX/UPS	1,273	1,273	1,273	1,273	5,092
Postal Costs	1,739	3,238	2,324	2,496	9,797
SYS Mgmt TVL	10,537	10,537	15,044	9,452	45,569
Natl Sec & Int TVL	98	98	824	2,520	3,539
Natl Sec Aff TVL	4,680	4,680	7,334	2,169	18,862
Conrad Chair TVL	2,686	2,686	5,878	4,606	15,856
Base Mgmt TVL	0	0	4,292	(1,098)	3,194
CIV STAFF	107,621	107,621	107,621	107,621	430,483
Dean- CIV FAC	34,535	34,535	34,535	34,535	138,140
MIL STAFF					
(2) 05	51,232	51,232	51,232	51,232	204,926
(1) 02	14,600	14,600	14,600	14,600	58,399
Dir Funded Resch	209,579	209,579	209,579	209,579	838,317
TOTAL	557,522	557,082	562,172	627,489	2,304,257

Eng & Comp Sci's					
Dean of Eng	1,501	1,501	35	580	3,617
Computer Sci	12,872	12,872	10,660	4,561	40,964
Math	17,748	17,748	7,609	5,492	48,597
Lab Maint	120,222	120,222	9,099	24,079	273,622
ECE	10,776	10,776	24,793	52,235	98,579
AERO	15,791	15,791	11,202	3,771	46,555
Mech Eng	12,444	12,444	12,393	4,768	42,048
Lab/Oth	31,481	31,481	38,004	42,022	142,987
Calibration	26,000	26,000	26,000	26,000	104,000

ACTIVITY	Q1	Q2	Q3	Q4	TOTAL
Student TxBks	26,919	27,375	24,494	26,299	105,087
Printing	24,250	24,250	24,250	123,250	196,000
AERO	1,734	1,734	6,050	221	9,738
EE/CE	827	827	510	2,788	4,951
NAV Eng	326	326	2,597	1,600	4,848
Copier Expense	9,827	9,827	9,827	9,827	39,307
FEDEX/UPS	972	972	972	972	3,888
Postal Costs	2,721	4,633	5,874	4,981	18,209
Dean of Eng TVL	3,560	3,560	-80	1,487	8,526
Computer Sci TVL	361	361	187	3,933	4,842
Math TVL	0	0	0	9,115	9,115
ECE TVL	366	366	334	18,228	19,293
AREO TVL	1,276	1,276	1,334	1,850	5,735
Mech Eng TVL	868	868	3,813	1,700	7,248
AERO TVL	809	809	2,623	-7	4,233
EE/CE TVL	1,635	1,635	2,502	363	6,134
NAV Eng TVL	264	264	1,378	-459	1,447
CIV STAFF	696,817	696,817	696,817	696,817	2,787,266
Dean- CIV FAC	34,535	34,535	34,535	34,535	138,140
Staff Enlisted					
(1) E7	12,391	12,391	12,391	12,391	49,563
(6) E6	64,251	64,251	64,251	64,251	257,004
(7) E5	62,662	62,662	62,662	62,662	250,649
(1) E4	7,380	7,380	7,380	7,380	29,520
Staff Off's					
(2) 05	51,232	51,232	51,232	51,232	204,926
(1) 03	18,086	18,086	18,086	18,086	72,343
Dir Funded Resch	307,809	307,809	307,809	307,809	1,231,234
TOTAL	1,580,713	1,583,081	1,481,623	1,624,819	6,270,215
Oper and App Sci					
OPS Research	21,329	21,329	12,679	7,729	63,066
Groups	19,422	19,422	(32,659)	39,042	45,226
Physics	12,249	12,249	12,291	9,065	45,854
Meteorology	6,310	6,310	4,815	3,245	20,680
Ocean	5,290	5,290	4,060	2,369	17,009
Dean of Ops	478	478	229	178	1,363
STL	1,747	1,747	44,179	(2,197)	45,475
Calibration	26,000	26,000	26,000	26,000	104,000
Student TxBks	43,458	44,941	42,891	45,934	177,224
Printing	10,938	10,938	10,938	10,938	43,750
OPS Research	653	653	5,177	430	6,912
Combat Sys	986	986	4,134	981	7,086
USW/Spc/EW	839	839	1,606	5,737	9,021

ACTIVITY	Q1	Q2	Q3	Q4	TOTAL
Air Ocean	1,515	1,515	1,012	1,789	5,831
Joint Warfare	10,034	10,034	30,762	21,953	72,782
Joint C4I (C3)	921	921	546	137	2,525
International	1,439	1,439	1,234	1,905	6,016
Copier Expense	10,551	10,551	10,551	10,551	42,204
FEDEX/UPS	370	370	370	370	1,479
Postal Costs	3,062	8,747	4,746	2,845	19,401
Joint Warfare TVL	48,922	48,922	72,196	37,006	207,045
OPS Res TVL	1,411	1,411	4,451	1,429	8,702
Groups TVL	0	0	974	1,518	2,492
Physics TVL	0	0	0	5,875	5,875
Meteorology TVL	125	125	0	4,028	4,278
Ocean TVL	464	464	756	1,392	3,076
Dean of Ops TVL	2,750	2,750	1,517	4,702	11,719
OPS research TVL	389	389	3,971	-383	4,366
Combat Sys TVL	943	943	1,195	2,031	5,111
USW/Spc/EW TV	132	132	893	890	21,157
C3 Travel	3,210	3,210	0	822	7,241
CIV STAFF	570,975	570,975	570,975	570,975	2,283,900
Dean- CIV FAC	34,535	34,535	34,535	34,535	138,140
Staff Enlisted					
(1) E7	12,391	12,391	12,391	12,391	49,563
(3) E6	32,126	32,126	32,126	32,126	128,502
(2) E5	17,904	17,904	17,904	17,904	71,614
Staff Off's					
(1) 06	29,625	29,625	29,625	29,625	118,498
(3) 05	76,847	76,847	76,847	76,847	307,389
Dir Funded Resch	252,006	252,006	252,006	252,006	1,008,023
TOTAL	1,262,346	1,269,514	1,297,923	1,273,830	5,103,595
Research Dept					
Dean of Resch	5,985	5,985	(4,639)	580	7,911
Printing	18,750	18,750	18,750	52,250	108,500
Copier Expense	1,298	1,298	1,298	1,298	5,191
FEDEX/UPS	64	64	64	64	254
Postal Costs	1,397	2,267	1,915	1,829	7,407
Dean of Resch TV	710	710	3,573	1,464	6,457
CIV STAFF	88,334	67,886	51,487	83,815	291,522
Dean- CIV FAC	34,535	34,535	34,535	34,535	138,140
TOTAL	151,073	131,495	106,983	175,835	565,382
Sch of Av Safety					
Aviation Safety	3,371	3,371	1,745	12,624	21,111
CMD Physician	0	0	0	2,000	2,000

ACTIVITY	Q1	Q2	Q3	Q4	TOTAL
Copier Expense	634	634	634	634	2,534
FEDEX/UPS	254	254	254	254	1,014
Postal Costs	215	720	718	666	2,318
Av Safety TVL	6,084	6,084	5,014	1,480	18,661
CMD Phy TVL	0	0	1,420	-16	1,404
CIV STAFF	16,155	16,667	16,315	14,503	63,640
MIL STAFF (1) 06	29,625	29,625	29,625	29,625	118,498
TOTAL	56,338	57,355	55,725	61,770	231,180
LIBRARY					
Library	466,342	466,342	45,556	68,505	1,046,745
FEDEX/UPS	5	5	5	5	20
Copier Expense	4,767	4,767	4,767	4,767	19,068
Library TVL	635	635	5,528	786	7,584
CIV STAFF	304,109	231,163	287,129	286,941	1,109,342
CIV FAC	34,535	34,535	34,535	34,535	138,140
TOTAL	810393	737447	377520	395539	2320899
Phones	105,750	105,750	424,000	210,000	845,500
Electricity	310,145	310,145	249,856	261,427	1,131,572
Natural Gas	51,226	51,226	1,576	1,576	105,603
Main Gas	43,057	43,057	60,002	40,921	187,036
Water	27,892	27,892	47,869	6,409	110,062
Sewer	21,535	21,535	18,458	12,306	73,833
Supply Dept					
Supply	7,327	7,327	4,664	56,611	75,929
MAT DIV	756	756	424	1,077	3,013
Copier Expense	1,339	1,339	1,339	1,339	5,355
Supply TVL	747	747	46	27	1,567
Supply CIV	336,370	344,824	344,824	348,979	1,374,996
Supply CIV	26,910	27,587	27,587	27,918	110,000
MIL STAFF					
(1) 04	21,496	21,496	21,496	21,496	85,983
(1) 03	18,086	18,086	18,086	18,086	72,343
(1) 02	14,600	14,600	14,600	14,600	58,399
(1) E7	12,391	12,391	12,391	12,391	49,563
(1) E6	10,709	10,709	10,709	10,709	42,834
(3) E5	26,855	26,855	26,855	26,855	107,421

ACTIVITY	Q1	Q2	Q3	Q4	TOTAL
TOTAL	477586	486717	483021	540088	1987403
Police Dept					
Copier Expense	319	319	319	319	1,274
Police	2,389	2,389	-153	1,493	6,118
Police CIV	159,026	163,078	163,078	165,041	650,224
TOTAL	161,734	165,786	163,244	166,853	657,616
Fire Dept					
FEDEX/UPS	5	5	5	5	20
Copier Expense	911	911	911	911	3,644
Fire Dept	2,174	2,174	1,601	55	6,004
Fire Dept CIV	207,796	213,210	213,210	215,774	849,991
TOTAL	210,886	216,300	215,727	216,745	859,659
Morale Wel & Rec					
MWR	5,426	5,426	12,673	52,499	76,025
Custodial	805	805	805	805	3,219
Copier Expense	386	386	386	386	1,545
Sports Ctr	2,500	2,500	0	-52	4,948
Treadmill	0	0	4,035	0	4,035
MWR CIV	96,916	99,352	99,352	100,549	396,170
MIL STAFF					
(1) E8	14,303	14,303	14,303	14,303	57,210
(1) E7	12,391	12,391	12,391	12,391	49,563
(1) E6	10,709	10,709	10,709	10,709	42,834
(5) E5	44,759	44,759	44,759	44,759	179,035
(3) E4	22,140	22,140	22,140	22,140	88,560
TOTAL	210335	212771	221553	258489	903144
Public Works Dept					
Boiler Plant	9,607	9,607	13,360	2,535	35,108
Eng Support	12,891	12,891	22,143	7,807	55,731
A & E Designs	64,171	64,171	162,629	335,127	626,098
FEDEX/UPS	95	95	95	95	380
Postal Expense	3,193	3,193	3,193	3,193	12,771
Shops- Matl	197,534	197,534	136,861	165,510	697,439
Const (R1)	0	0	0	19,075	19,075
Printing	5,250	5,250	5,250	(4,750)	11,000
MIL STAFF					
(1) 05	25,616	25,616	25,616	25,616	102,463
(1) 03	18,086	18,086	18,086	18,086	72,343
(1) 01-	10,713	10,713	10,713	10,713	42,850
(1) E7	12,391	12,391	12,391	12,391	49,563



ACTIVITY	Q1	Q2	Q3	Q4	TOTAL
(1) E6	10,709	10,709	10,709	10,709	42,834
(7) E5	62,662	29,520	29,520	29,520	250,649
(4) E4	29,520	29,520	29,520	29,520	118,080
(2) E3	12,673	12,673	12,673	12,673	50,692
PW- MRP CIV	510,650	523,484	523,484	529,792	2,087,409
PW- Boiler CIV	69,729	71,507	71,507	72,367	285,111
PW-Eng CIV	179,133	183,635	183,635	185,848	732,250
Maint Fac Contr's	203,366	203,366	182,029	1,141,507	1,730,268
Transportation	32,039	32,039	22,783	24,662	111,524
PW-Transportation	30,357	31,119	31,119	31,495	124,091
TOTAL	1500385	1487119	1507316	2663491	7257729
Environmental					
Environmental	49,069	49,069	(13,171)	25,096	110,063
PW-Environ CIV	31,721	32,519	32,519	32,910	129,668
TOTAL	80790	81588	19348	58006	239731
Refuse	44,229	44,229	22,668	31,798	142,924
Custodial NPS	285,793	285,793	285,793	285,793	1,143,169
Custod LA MESA	738	738	738	738	2,951
Grnds Maint NPS	46,759	46,759	46,759	46,759	187,036
Grnds M LA MESA	37,968	37,968	37,968	37,968	151,873

... ..

## APPENDIX C. COMPOSITE STANDARD MILITARY RATES

This appendix provides a listing of Navy and Marine Corps Military Composite Pay Rates. The pay rates include the cost of salaries and fringe benefits.

Pay Grade	Annual Rate
O-8	\$ 142,863
O-6	\$ 118,498
O-5	\$ 102,463
O-4	\$ 85,983
O-3	\$ 72,343
O-2	\$ 58,399
O-1	\$ 42,850
W-3	\$ 64,511
E-8	\$ 57,210
E-7	\$ 49,563
E-6	\$ 42,834
E-5	\$ 35,807
E-4	\$ 29,520
E-3	\$ 25,346
E-2	\$ 23,045
E-1	\$ 20,306



## APPENDIX D. DEMAND BOX ABBREVIATIONS

Abbreviation	Name
MSSC	MANAGEMENT AND SECURITY STUDIES (CODE 06) COSTS
ECSC	ENGINEERING AND COMPUTATIONAL SCIENCES (CODE 07) COSTS
OASC	OPERATIONAL AND APPLIED SCIENCE (CODE 08) COSTS
RESC	RESEARCH DEPARTMENT (CODE 09) COSTS
SASC	SCHOOL OF AVIATION SAFETY (CODE 10) COSTS
NMC	RESIDUAL COSTS

8. 40. 17

## APPENDIX E. SUPPLY BOX ABBREVIATIONS

Abbreviation	Name
18SU	PHONES
19SU	ELECTRICITY
20SU	NATURAL GAS
21SU	MAIN GAS
22SU	WATER
23SU	SEWAGE
24SU	REFUSE
25SU	CUSTODIAL (NAVAL POSTGRADUATE SCHOOL)
25A	CUSTODIAL (LA MESA)
27SU	GROUNDS MAINTENANCE (NAVAL POSTGRADUATE SCHOOL)
27A	GROUNDS MAINTENANCE (LA MESA)

1953-54



## APPENDIX F. SUMMARY BOX ABBREVIATIONS

Abbreviations	Name
00SU 00SA	SUPERINTENDENT
01SU 01SA	PROVOST
03SU 03SA	DEAN OF STUDENTS
04SU	NAVAL SUPPORT ACTIVITY
05SU	COMPUTER INFORMATION SERVICES
06SU 06SA	MANAGEMENT AND SECURITY STUDIES
07SU 07SA	ENGINEERING AND COMPUTATIONAL SCIENCES
08SU 08SA	OPERATIONAL AND APPLIED SCIENCE
09SU 09SA	RESEARCH DEPARTMENT
10SU 10SA	SCHOOL OF AVIATION SAFETY
11SU 11SA	DUDLEY KNOX LIBRARY
12SU 12SA	SUPPLY DEPARTMENT
13SU 13SA	POLICE DEPARTMENT

Abbreviations	Name
14SU 14SA	FIRE DEPARTMENT
15SU	MORALE, WELFARE AND RECREATION
16SU	PUBLIC WORKS DEPARTMENT
17SU	ENVIRONMENTAL
CSB1	CUMULATIVE COST SUMMARY BOX FOR 22SU, 23SU, AND 24SU
CSB3	CUMULATIVE COST SUMMARY BOX FOR 19SU, 20SU, 21SU, 25SU, AND 27SU
CSB5	CUMULATIVE COST SUMMARY BOX FOR 25A AND 27A
COMP	COMPTROLLER
TIME	TIMEKEEPING (PAYROLL)
CD22	HUMAN RESOURCES (HRSC)
NMSU NMSA	RESIDUAL COSTS

**APPENDIX G. STEP DOWN COST ALLOCATION ORDER**

Activity

ENVIRONMENTAL

PUBLIC WORKS DEPARTMENT

NAVAL SUPPORT ACTIVITY, MONTEREY BAY

HUMAN RESOURCES OFFICE

COMPTROLLER

TIMEKEEPING (PAYROLL)

COMPUTER INFORMATION SERVICES

MORALE, WELFARE AND RECREATION

POLICE DEPARTMENT

FIRE DEPARTMENT

SUPPLY DEPARTMENT

SUPERINTENDENT

PROVOST

DUDLEY KNOX LIBRARY

DEAN OF STUDENTS



## APPENDIX H. SQUARE FOOTAGE ESTIMATES

Square Footage	Activity
5,258	SUPERINTENDENT
19,599	PROVOST
3,110	HUMAN RESOURCES OFFICE (HRSC)
4,887	COMPTROLLER
889	TIMEKEEPING (PAYROLL)
65,056	DEAN OF STUDENTS
131,425	NAVAL SUPPORT ACTIVITY, MONTEREY BAY
23,190	COMPUTER INFORMATION SERVICES
42,845	MANAGEMENT AND SECURITY STUDIES
375,709	ENGINEERING AND COMPUTATIONAL SCIENCES
191,696	OPERATIONAL RESEARCH AND APPLIED SCIENCE
12,899	RESEARCH DEPARTMENT
9,414	SCHOOL OF AVIATION SAFETY
92,932	DUDLEY KNOX LIBRARY
8,807	SUPPLY DEPARTMENT
6,279	POLICE DEPARTMENT
5,278	FIRE DEPARTMENT

Square Footage

Activity

119,818

PUBLIC WORKS DEPARTMENT

159,975

TENANT COMMANDS

**APPENDIX I. NUMBER OF PERSONNEL FOR FY 96**

Ttl. Number	Nbr. of Military	Nbr. of Civilian	Activity
17	8	9	SUPERINTENDENT
26	0	26	PROVOST
22	0	22	COMPTROLLER
14	0	14	HUMAN RESOURCES OFFICE
4	0	4	TIMEKEEPING (PAYROLL)
36	8	28	DEAN OF STUDENTS
74	40	34	NAVAL SUPPORT ACTIVITY
36	2	34	COMPUTER INFORMATION SERVICES
87	13	74	MANAGEMENT AND SECURITY STUDIES
167	26	141	ENGINEERING AND COMPUTATIONAL SCIENCES
135	22	113	OPERATIONAL AND APPLIED SCIENCE
9	0	9	RESEARCH DEPARTMENT
11	9	2	SCHOOL OF AVIATION SAFETY
29	0	29	DUDLEY KNOX LIBRARY
91	18	73	PUBLIC WORKS DEPARTMENT
3	0	3	ENVIRONMENTAL
18	0	18	POLICE DEPARTMENT

Ttl. Nbr.	Nbr. of Military	Nbr. of Civilian	Activity
18	0	18	FIRE DEPARTMENT
48	8	40	SUPPLY DEPARTMENT
20	11	9	MORALE, WELFARE AND RECREATION



**APPENDIX J. AVERAGE NUMBER OF STUDENTS ON BOARD FOR FY 96**

Average Number of Students	Activity
568	MANAGEMENT AND SECURITY STUDIES
352	ENGINEERING AND COMPUTATIONAL SCIENCES
510	OPERATIONAL AND APPLIED SCIENCE
153	SCHOOL OF AVIATION SAFETY



## APPENDIX K. DEMAND BOXES

Representative of the

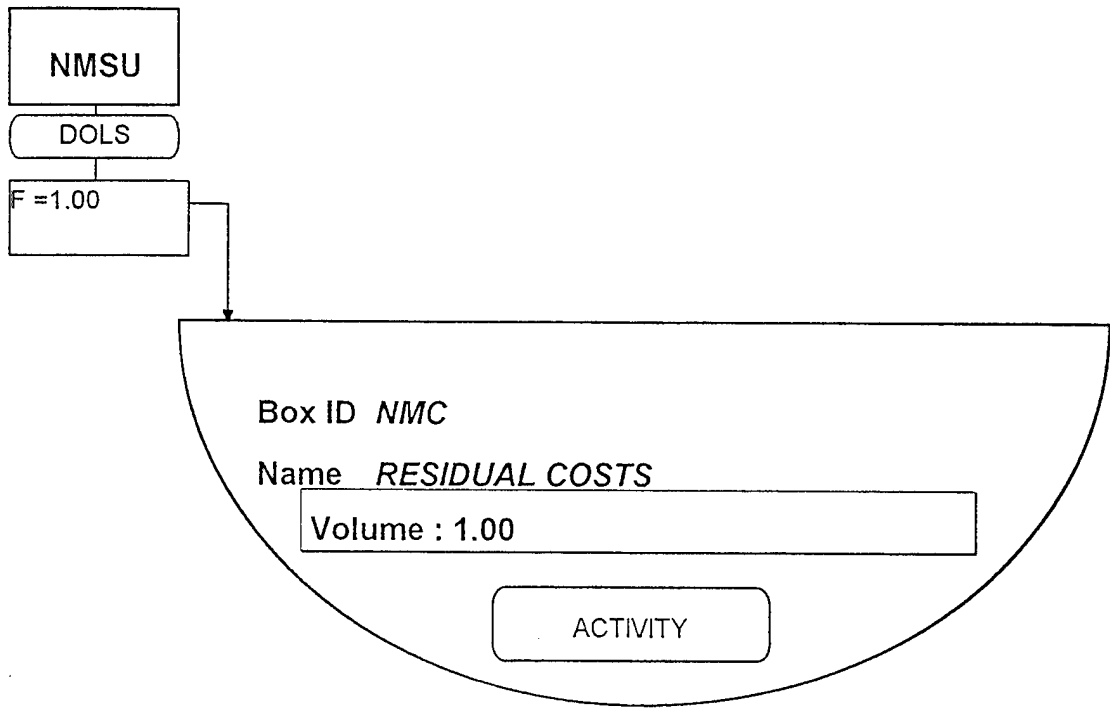

10SU

DOLS

F = 1.00

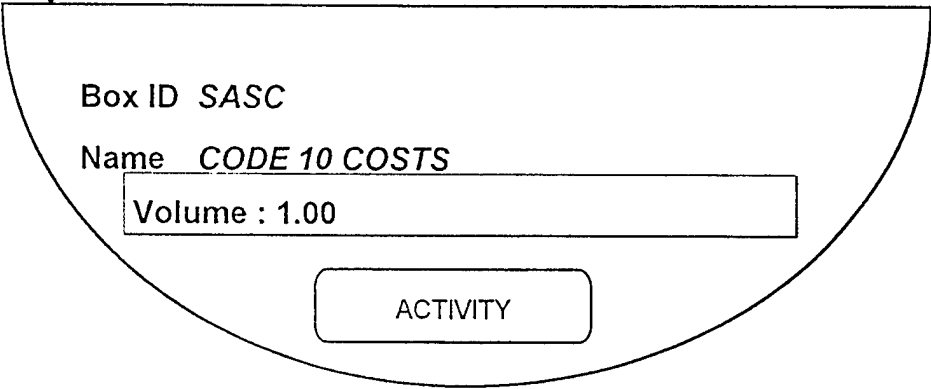

09SU

DOLS

F = 1.00

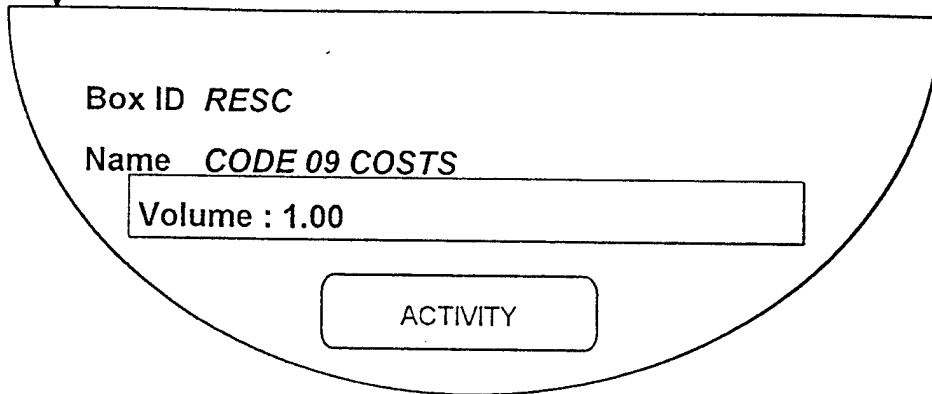

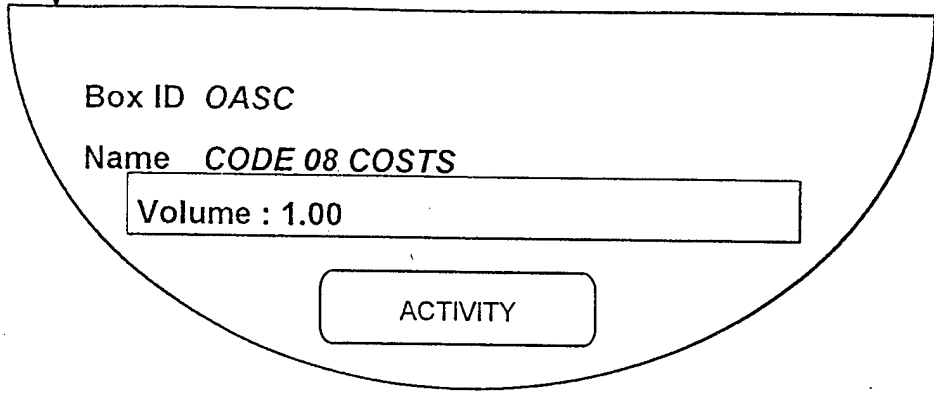
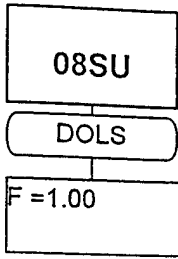

07SU

DOLS

F = 1.00

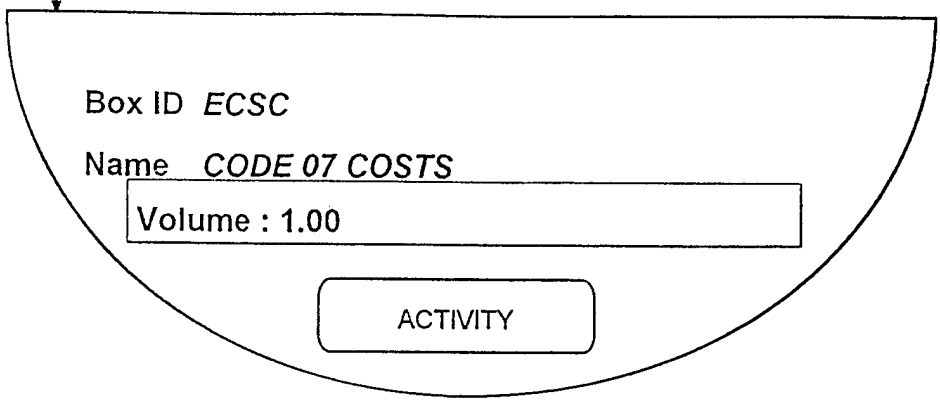



06SU

DOLS

F=1.00

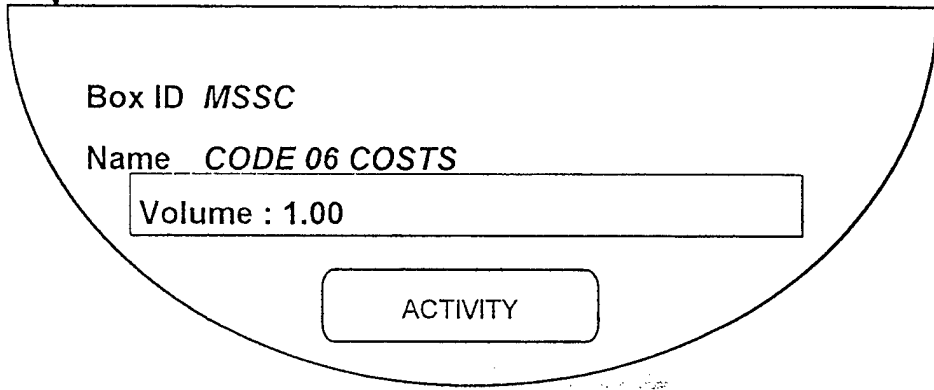



## APPENDIX L. SUPPLY BOXES

APPENDIX L. SUPPLY BOXES

\$ GROUNDS MAINT NPS  
187036.00

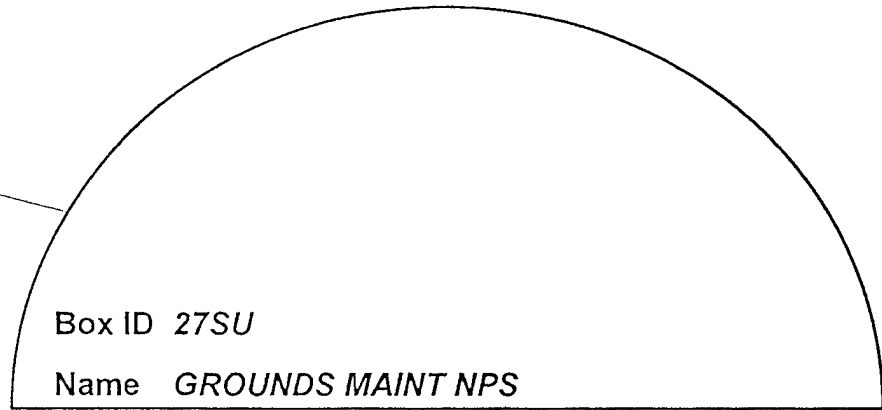

Capacit  
INFINITE

DOLS



\$ GROUNDS MAINT LA MES  
151873.00

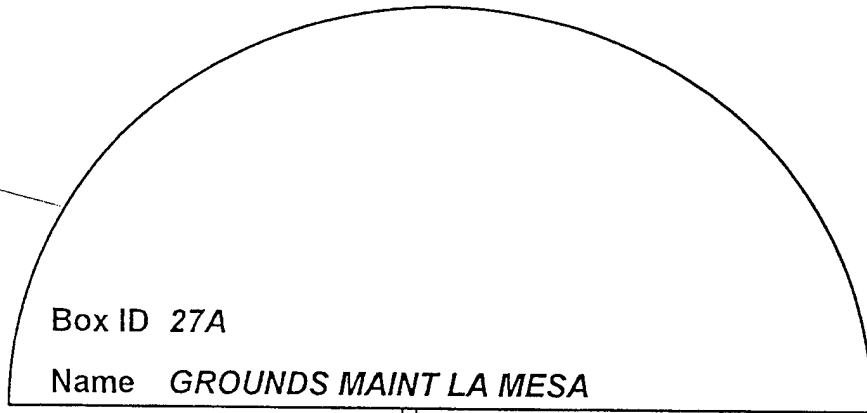

Capacity  
INFINITE

DOLS

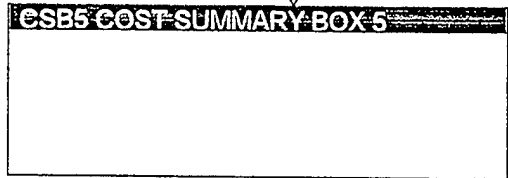

\$ CUSTODIAL NPS  
1143169.0

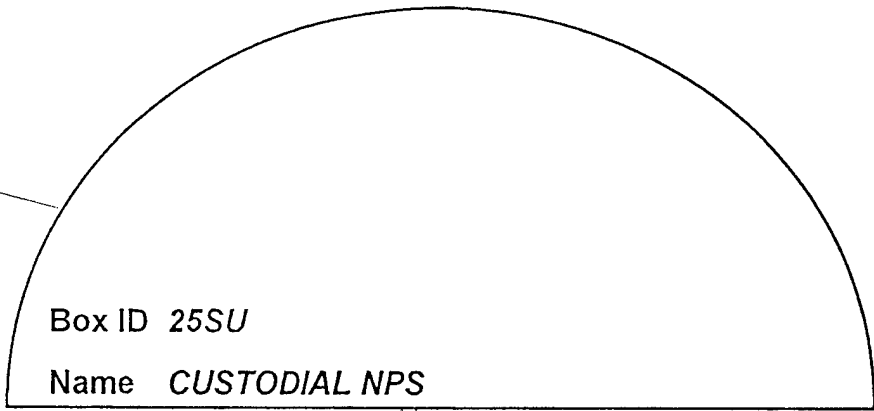

Capacity  
INFINITE

DOLS

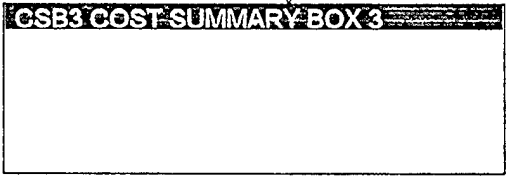

\$ CUSTODIAL LA MESA  
2951.00

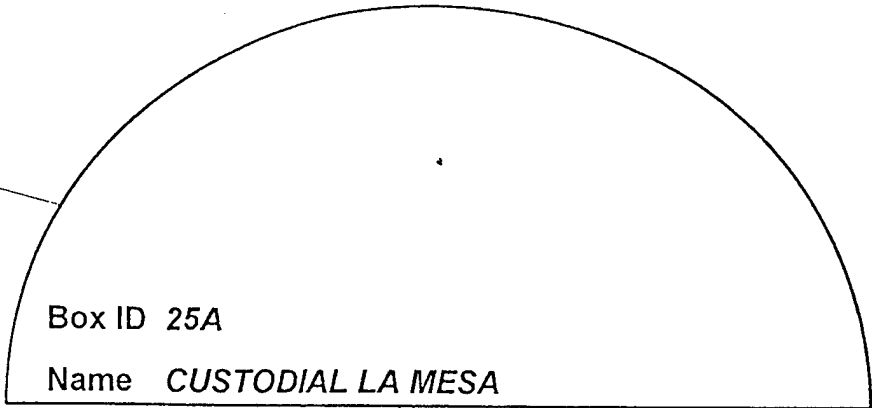

Capacity  
INFINITE

DOLS

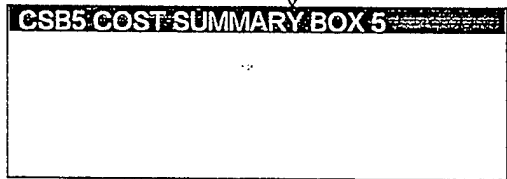

\$ REFUSE  
142924.00

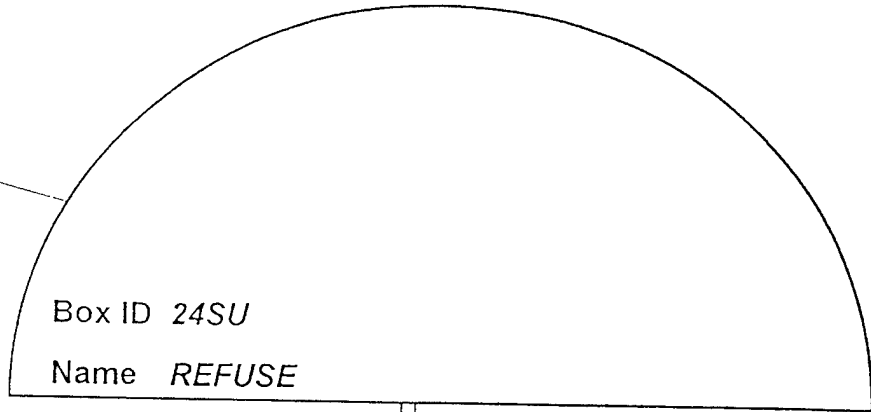

Capacity  
INFINITE

DOLS

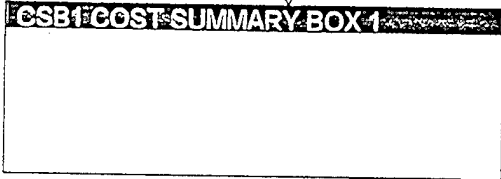



\$ SEWAGE  
73833.00

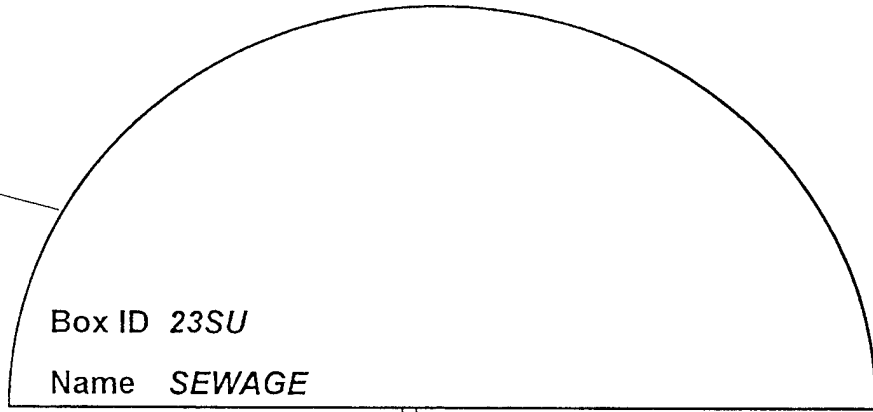

Capacity  
INFINITE

DOLS



\$ WATER  
110062.00

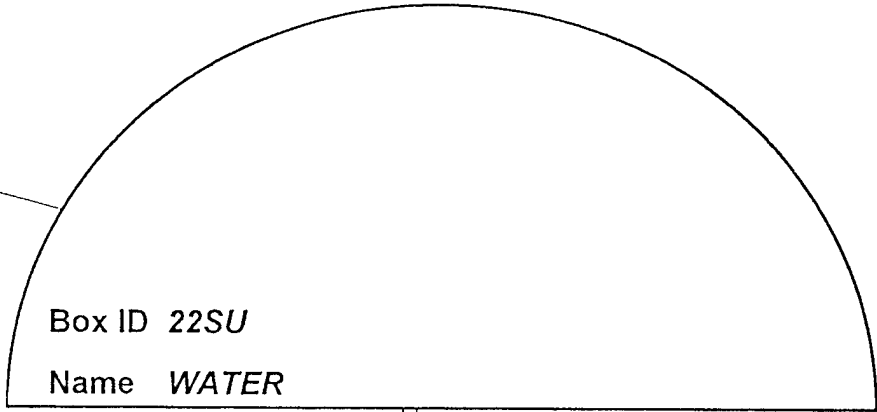

Capacit  
INFINITE

DOLS

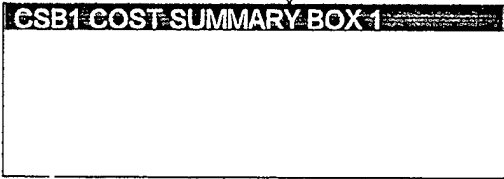

\$ MAIN GAS  
187036.00

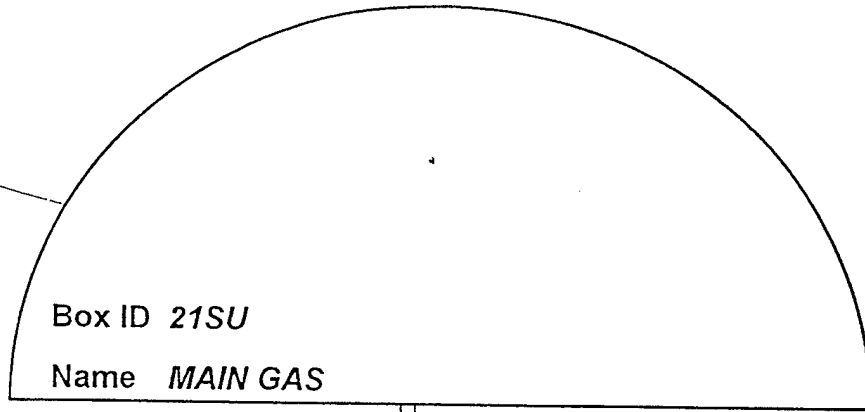

Capacity  
INFINITE

DOLS

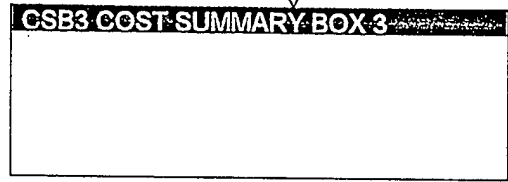

\$ NATURAL GAS  
105603.00

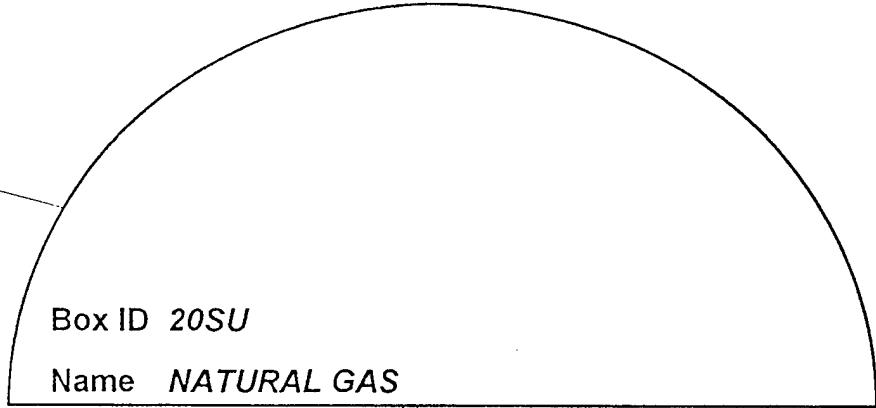

Capacity  
INFINITE

DOLS

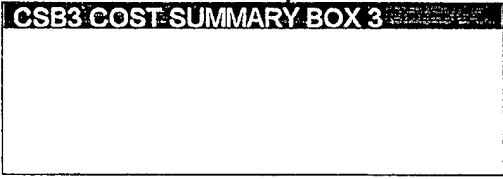

\$ ELECTRICITY  
1131572.0

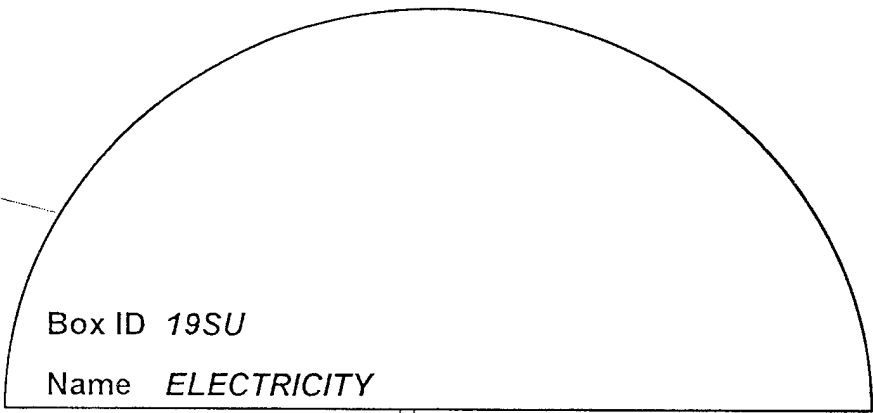

Capacity  
INFINITE

DOLS

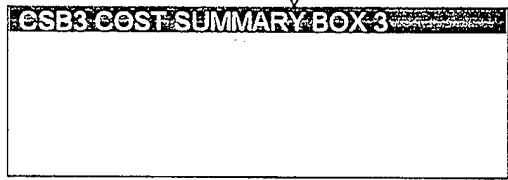

\$ PHONES  
845500.00

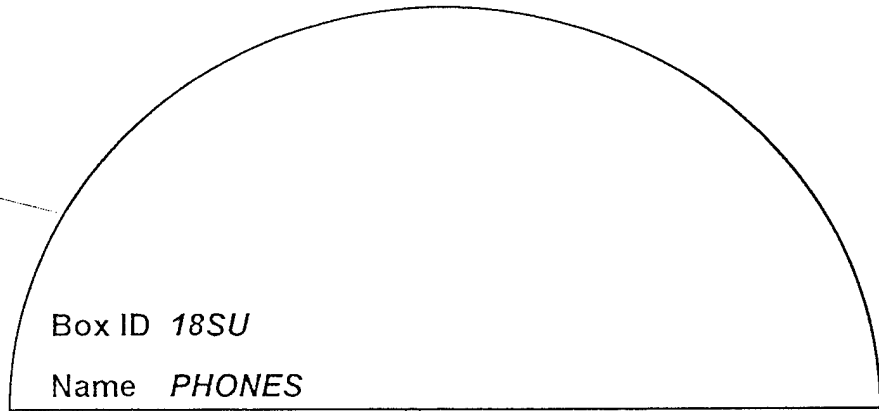

Capacity  
INFINITE

DOLS

16SU PUBLIC WORKS
17SU ENVIRONMENTAL
04SU NAVAL SUPPORT ACTIVITY
COMP COMPTROLLER
TIME TIMEKEEPING
15SU MWR
13SU POLICE DEPT
14SU FIRE DEPT
05SU COMPUTER INFO SVCS
12SU SUPPLY DEPT
11SU LIBRARY
00SU SUPERINTENDENT
01SU PROVOST
03SU DEAN OF STUDENTS
NMSU RESIDUAL SUMMARY
06SU CODE 06 SUMMARY BOX
07SU CODE 07 SUMMARY BOX
08SU CODE 08 SUMMARY BOX
09SU CODE 09 SUMMARY BOX
10SU CODE 10 SUMMARY BOX
CD22 HRSC







## APPENDIX M. NUMBER OF PHONE LINES

Number of Phone Lines	Activity
50	SUPERINTENDENT
121	PROVOST
55	HUMAN RESOURCES OFFICE (HRSC)
86	COMPTROLLER
16	TIMEKEEPING (PAYROLL)
224	DEAN OF STUDENTS
140	NAVAL SUPPORT ACTIVITY, MONTEREY BAY
223	COMPUTER INFORMATION SERVICES
302	MANAGEMENT AND SECURITY STUDIES
920	ENGINEERING AND COMPUTATIONAL SCIENCES
527	OPERATIONAL AND APPLIED SCIENCE
48	RESEARCH DEPARTMENT
8	SCHOOL OF AVIATION SAFETY
41	DUDLEY KNOX LIBRARY
66	SUPPLY DEPARTMENT
12	POLICE DEPARTMENT
21	FIRE DEPARTMENT
74	MORALE, WELFARE AND RECREATION

Number of Phone Lines

Activity

154

PUBLIC WORKS DEPARTMENT

5

ENVIRONMENTAL

10

NON-MISSION

**APPENDIX N. SUMMARY BOXES**

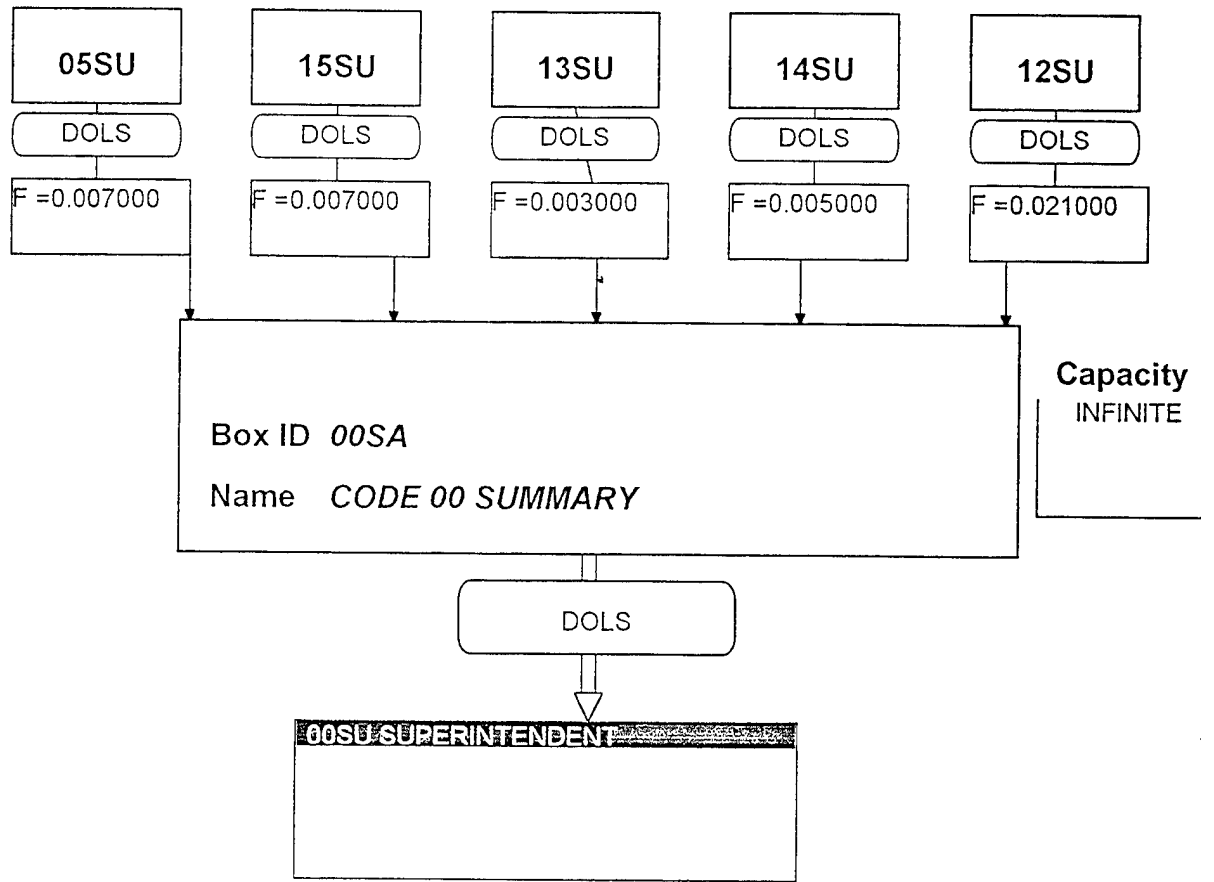

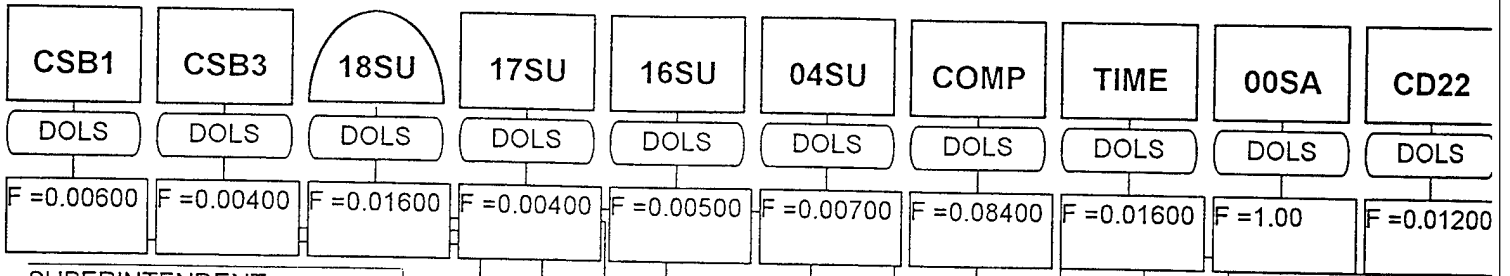

\$ SUPERINTENDENT  
1326812.0

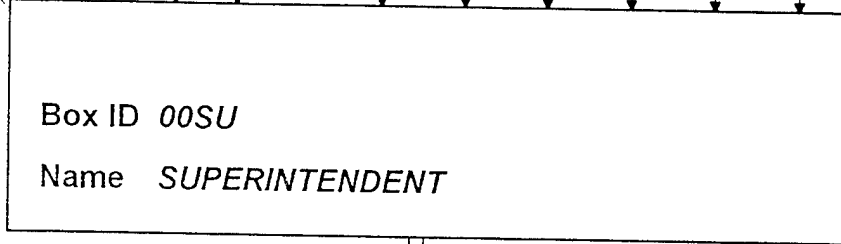

Capacity  
INFINITE

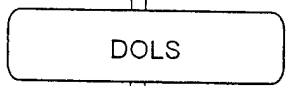

NMSA RESIDUAL SUMMARY	
10SA CODE 10	SUMMARY
09SA CODE 09	SUMMARY
08SA CODE 08	SUMMARY
07SA CODE 07	SUMMARY
06SA CODE 06	SUMMARY
03SA CODE 03	SUMMARY
01SA CODE 01	SUMMARY

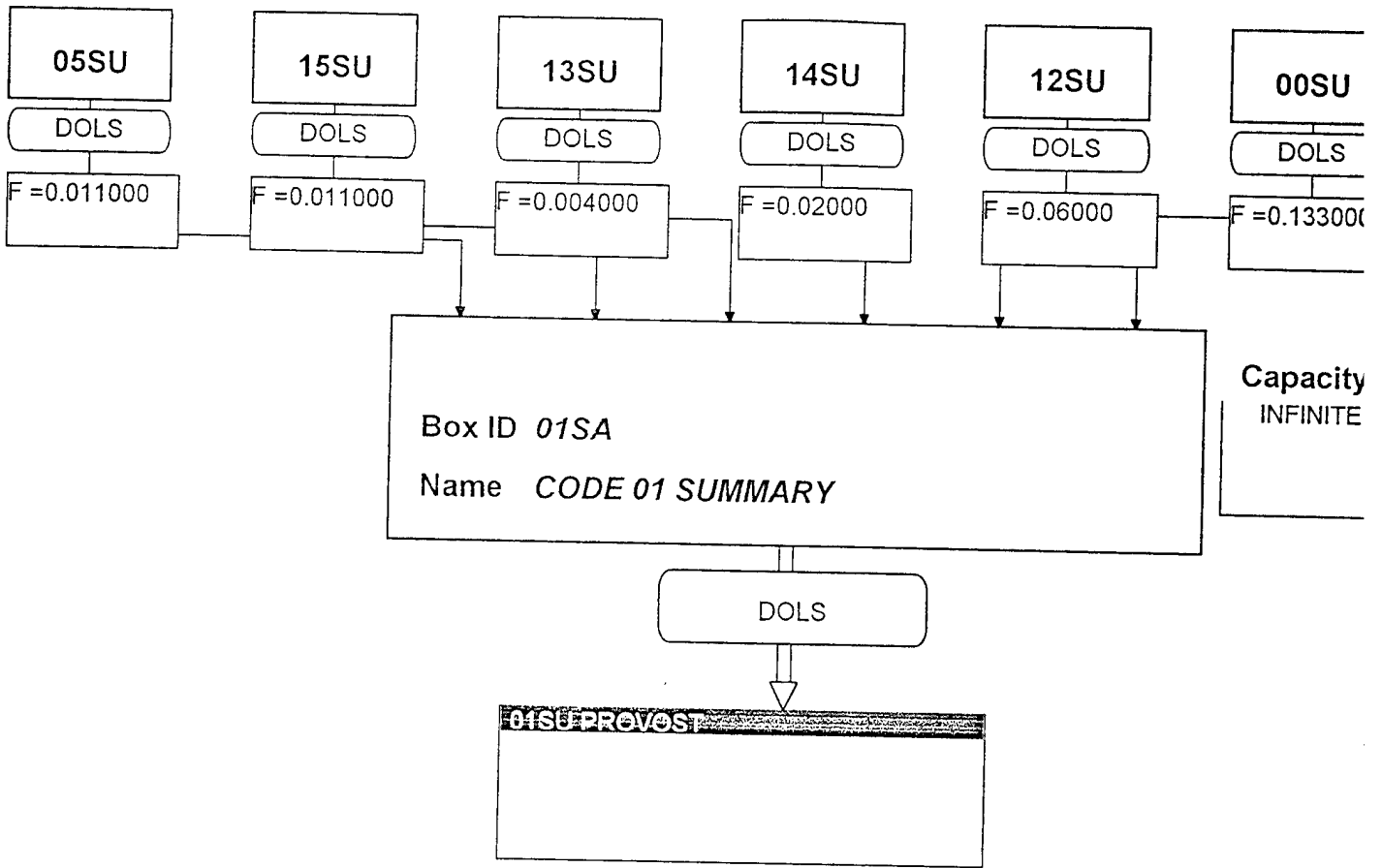

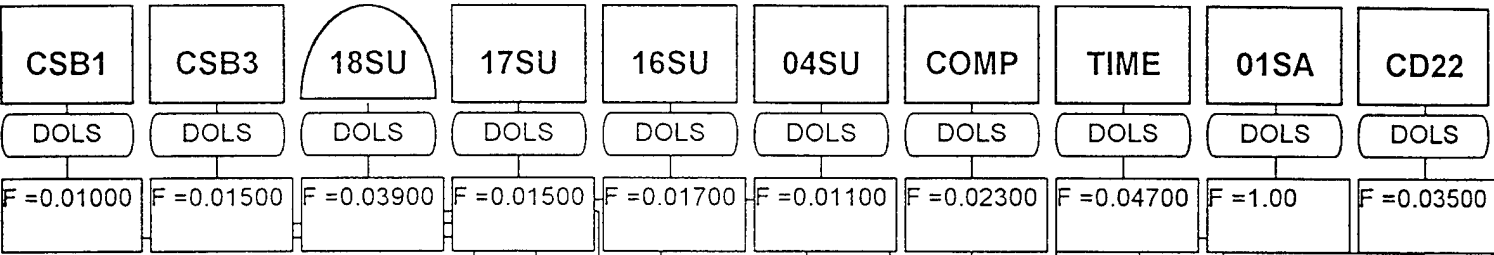

PROVOST  
\$ 1805222.0

Box ID 01SU  
Name PROVOST

Capacity  
INFINITE

DOLS

~~09SA CODE 09 SUMMARY~~  
08SA CODE 08 SUMMARY  
07SA CODE 07 SUMMARY  
06SA CODE 06 SUMMARY  
11SA CODE 11 SUMMARY

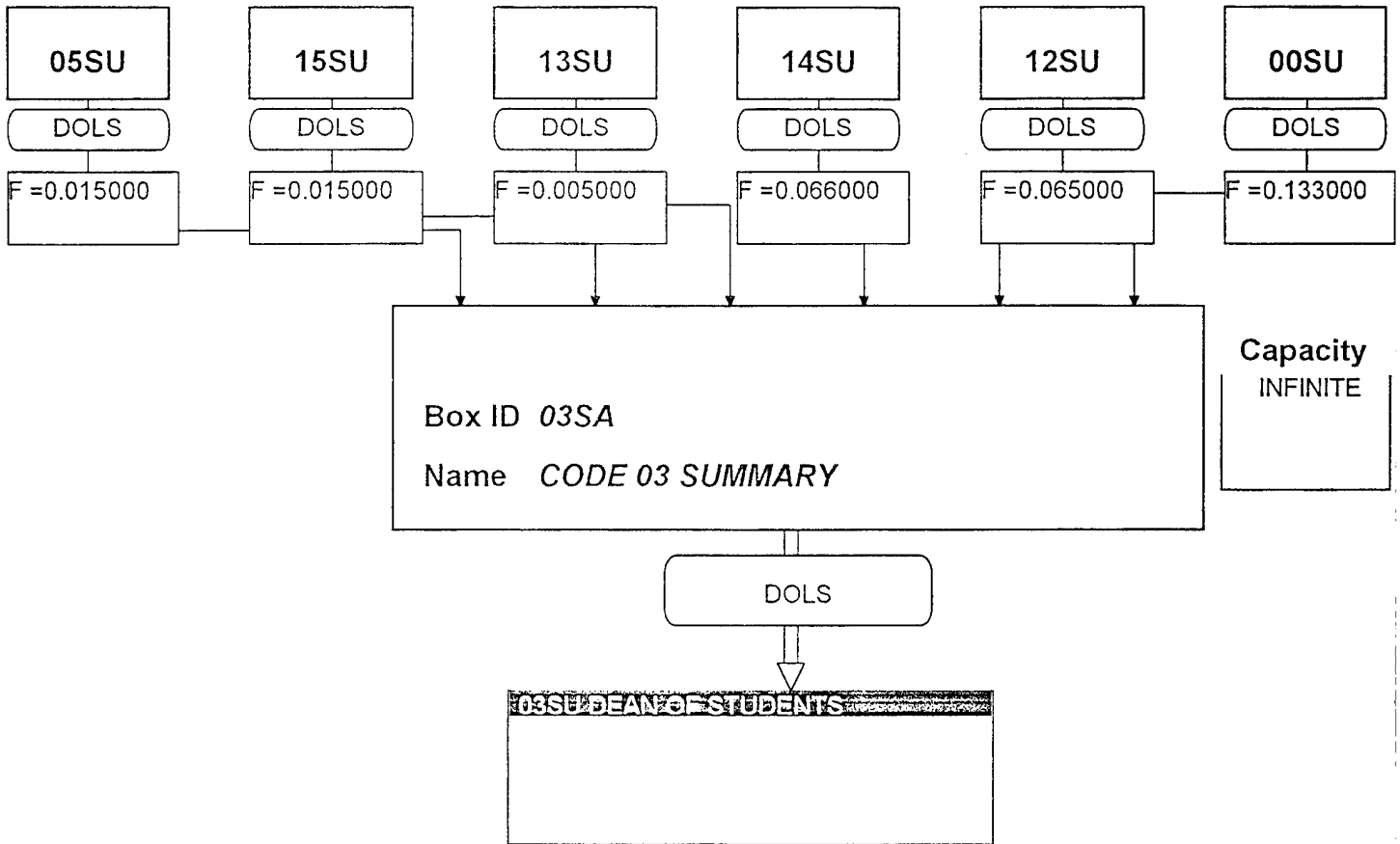



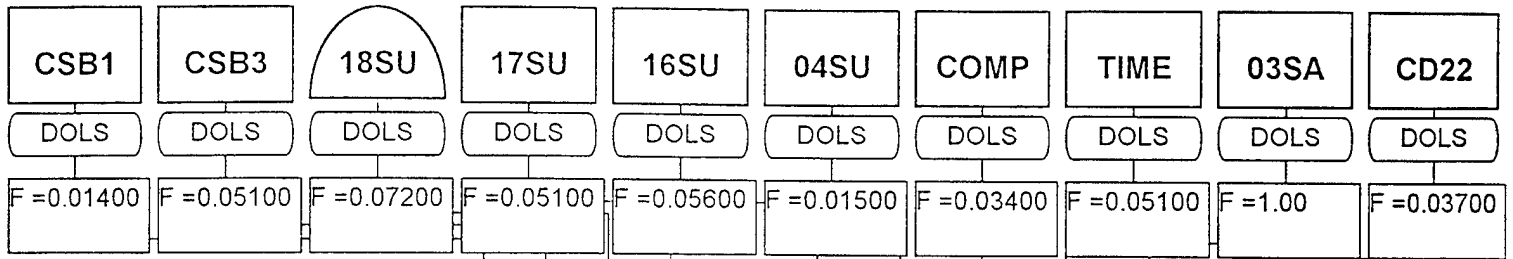

\$ DEAN OF STUDENTS  
1820347.0

Box ID 03SU  
Name DEAN OF STUDENTS

Capacity  
INFINITE

DOLS

~~08SA CODE 08 SUMMARY~~  
07SA CODE 07 SUMMARY  
06SA CODE 06 SUMMARY

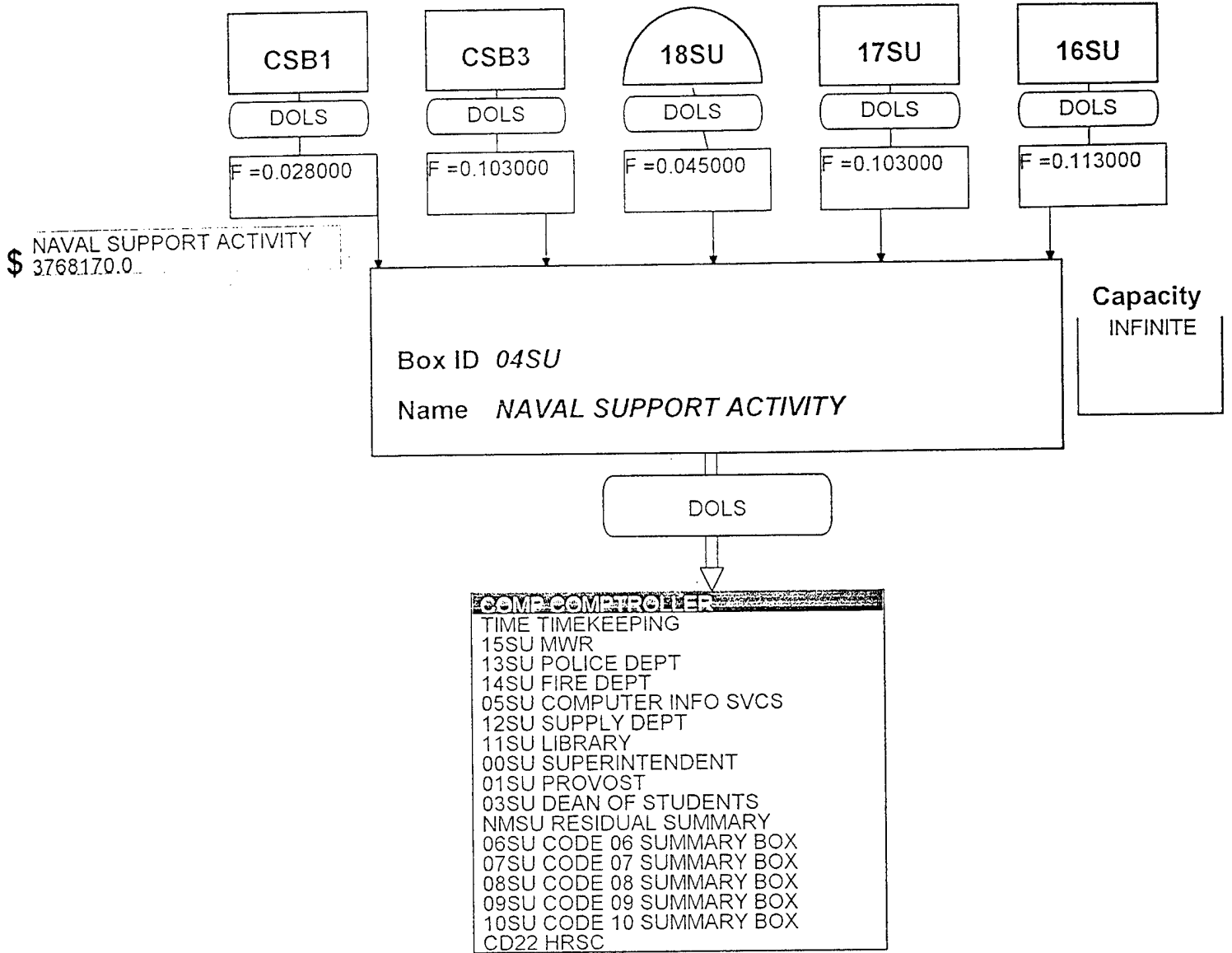

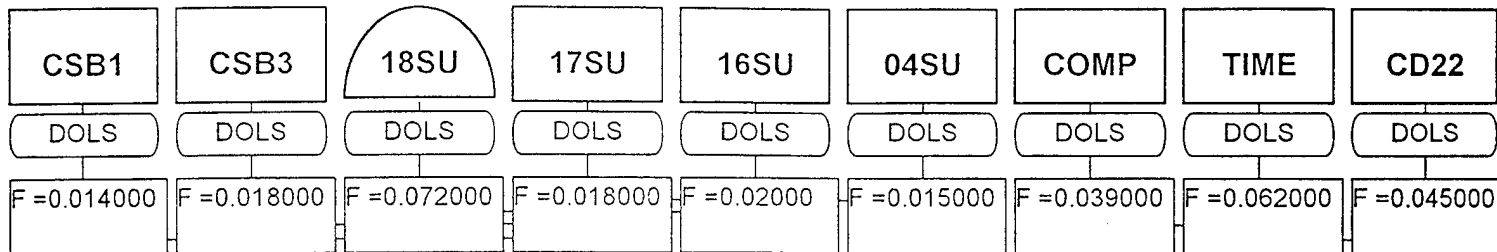

COMPUTER INFO SVCS  
3645912.0

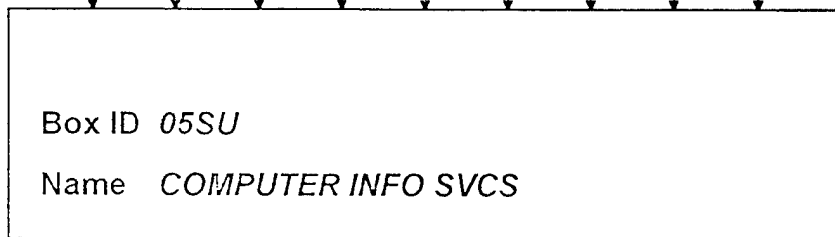

Capacity  
INFINITE

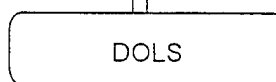

5555MWR  
NMSA RESIDUAL SUMMARY  
10SA CODE 10 SUMMARY  
09SA CODE 09 SUMMARY  
08SA CODE 08 SUMMARY  
07SA CODE 07 SUMMARY  
06SA CODE 06 SUMMARY  
03SA CODE 03 SUMMARY  
01SA CODE 01 SUMMARY  
00SA CODE 00 SUMMARY  
11SA CODE 11 SUMMARY  
12SA SUPPLY DEPT SUMMARY  
14SA FIRE DEPT SUMMARY  
13SA POLICE DEPT SUMMARY

05SU	15SU	14SU	13SU	12SU	00SU	01SU	11SU	03SU	CSB5
DOLS	DOLS	DOLS	DOLS	DOLS	DOLS	DOLS	DOLS	DOLS	DOLS
F =0.27600	F =0.27800	F =0.04400	F =0.34900	F =0.17200	F =0.13300	F =0.29800	F =0.29700	F =0.39700	F =0.39700

Box ID 06SA  
Name CODE 06 SUMMARY

Capacity  
INFINITE

DOLS

~~06SU CODE 06 SUMMARY BOX~~

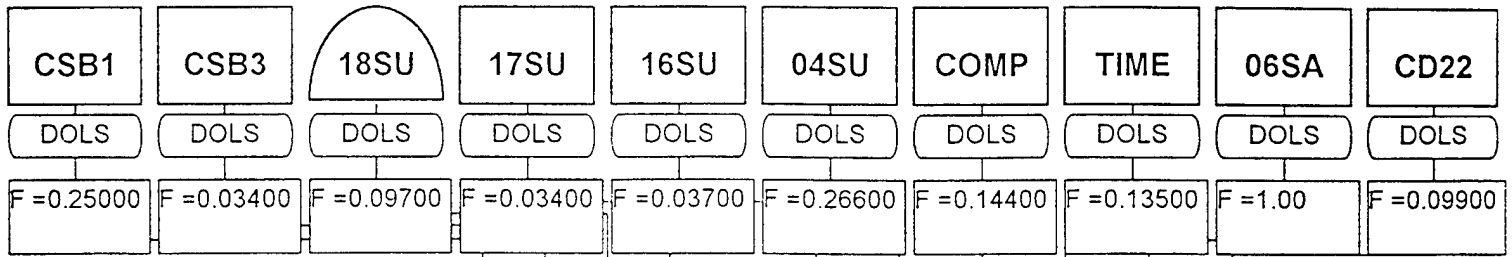

\$ CODE 06 COSTS  
2304257.0

Box ID 06SU  
Name CODE 06 SUMMARY BOX

Capacity  
INFINITE

DOLS

MSSC CODE 06 COSTS

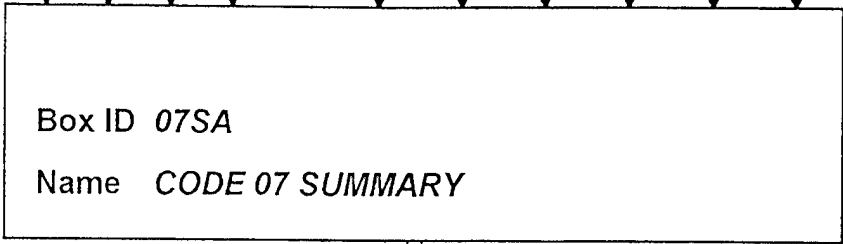
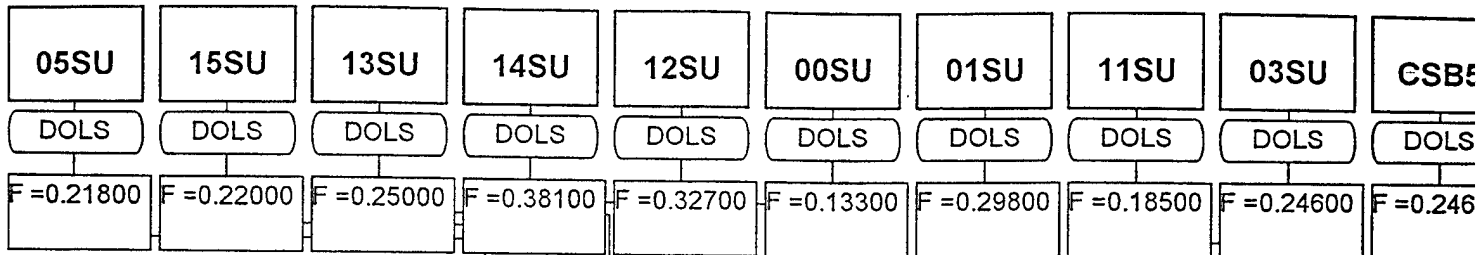

Capacity  
INFINITE

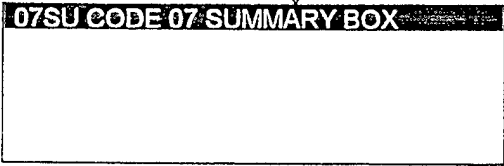
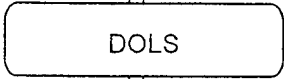

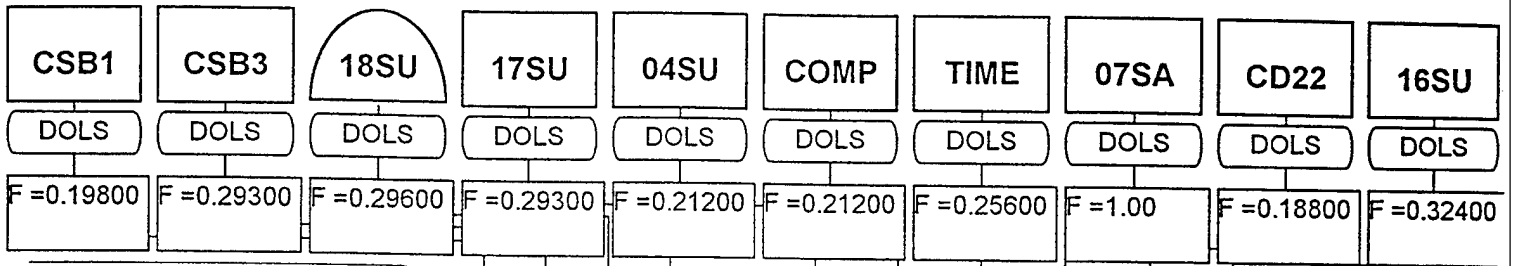

\$ CODE 07 COSTS  
6270215.0

Box ID 07SU  
Name CODE 07 SUMMARY BOX

Capacity  
INFINITE

DOLS

**ECSC CODE 07 COSTS**

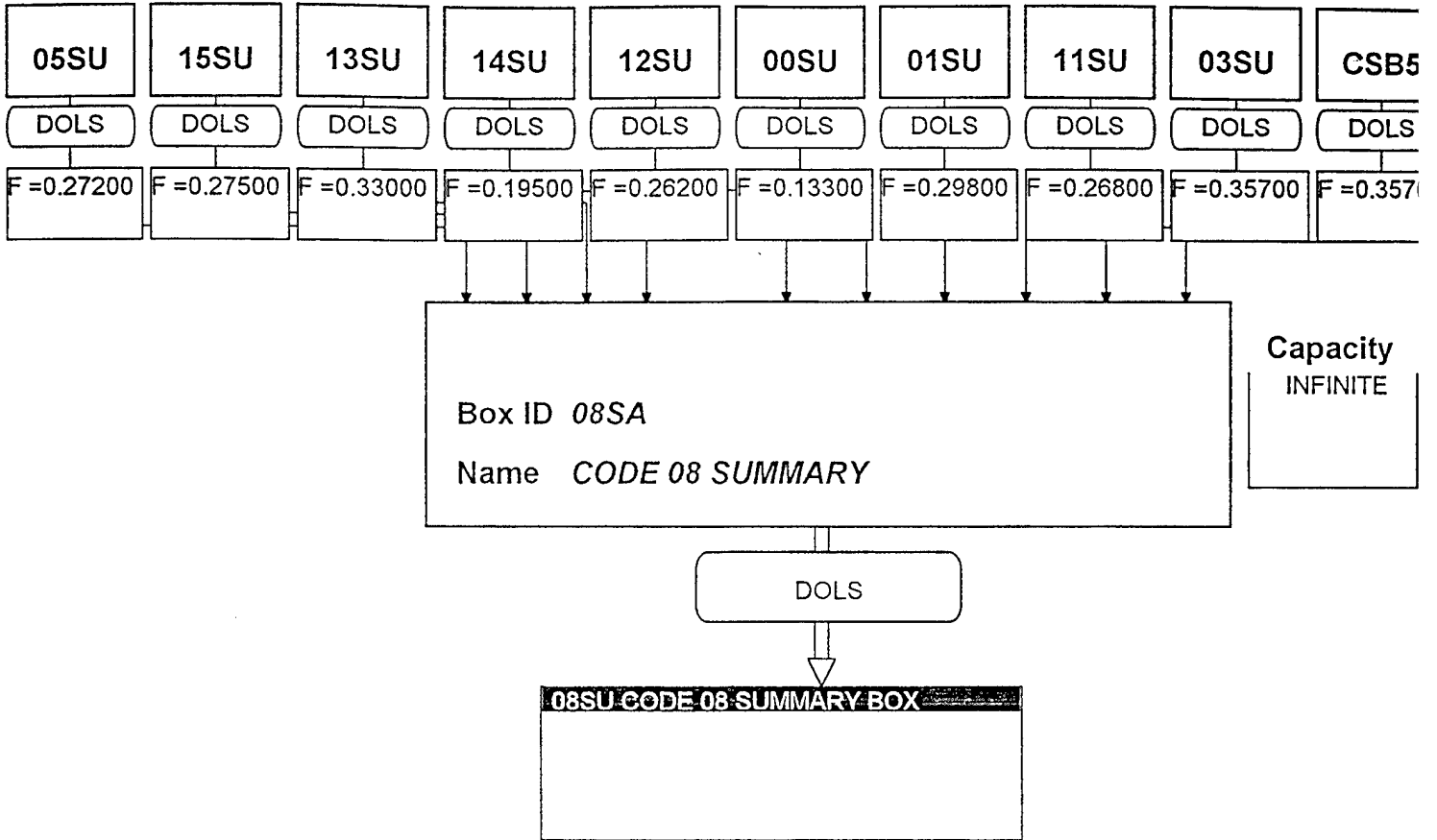



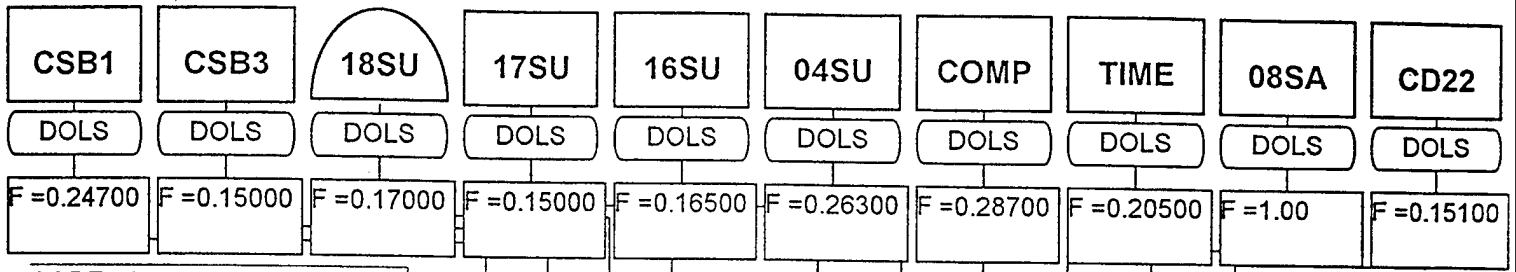

\$ CODE 08 COSTS  
5103595.0

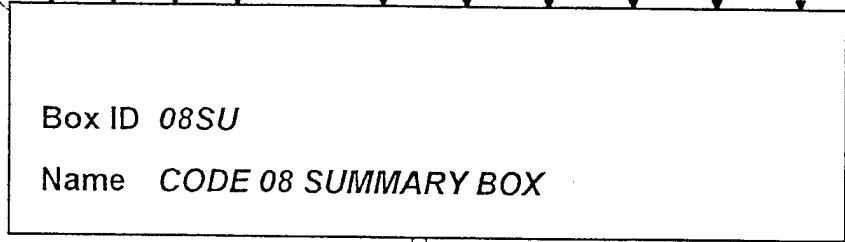

Capacity  
INFINITE

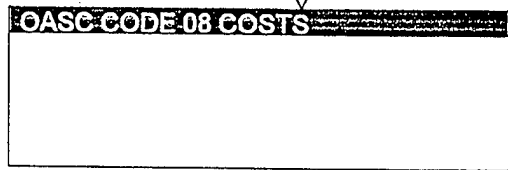
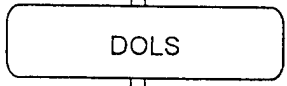

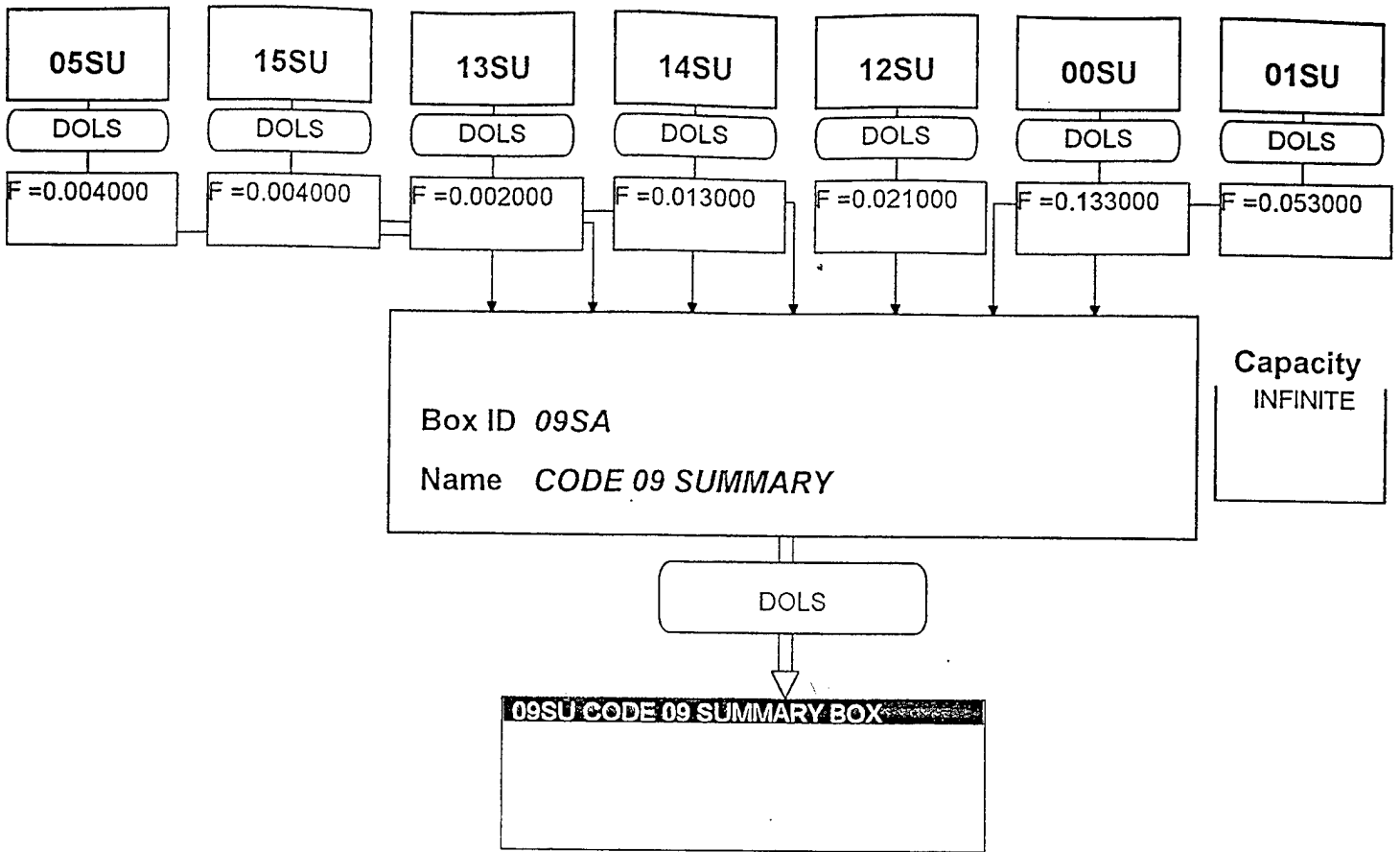

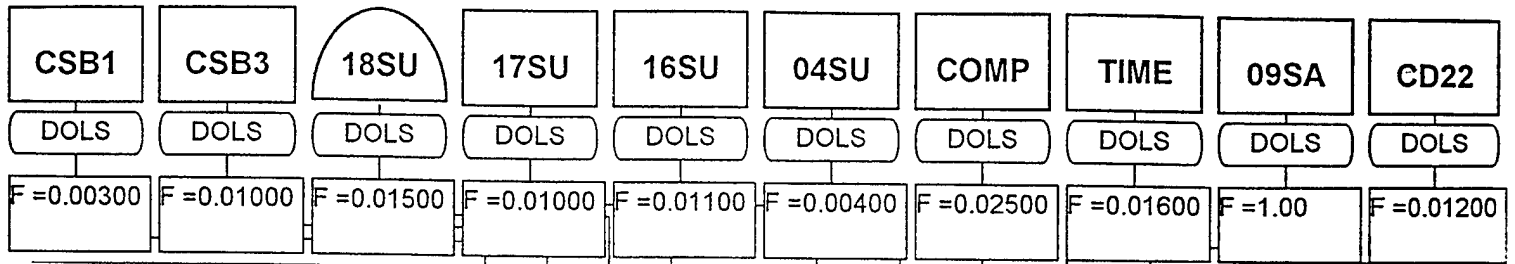

\$ CODE 09 COSTS  
565382.00

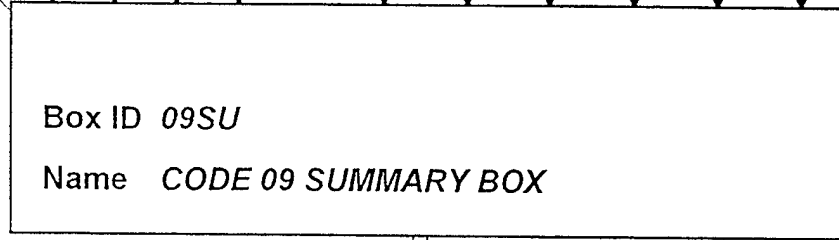

Capacity  
INFINITE

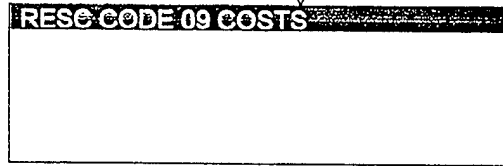
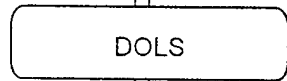

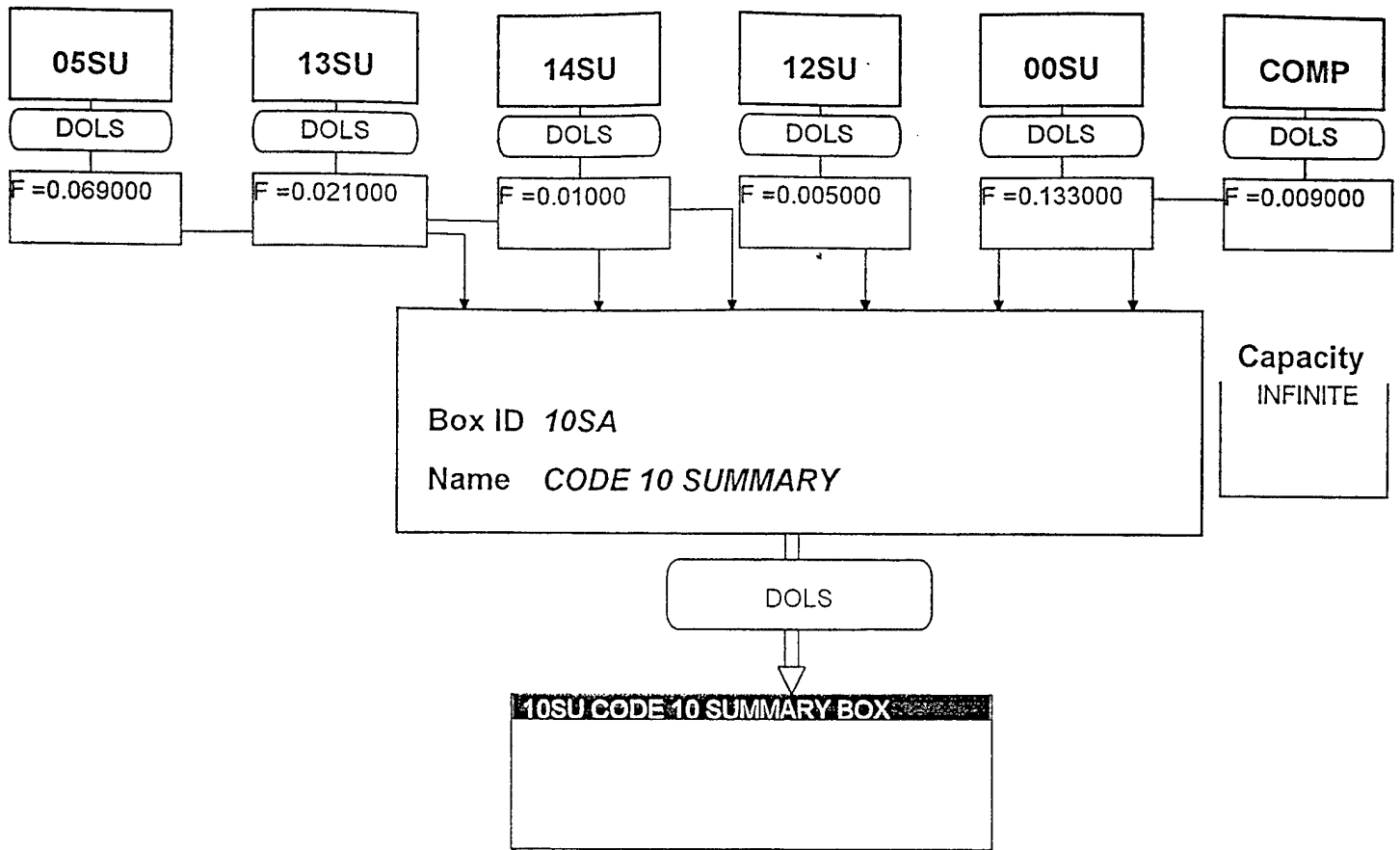

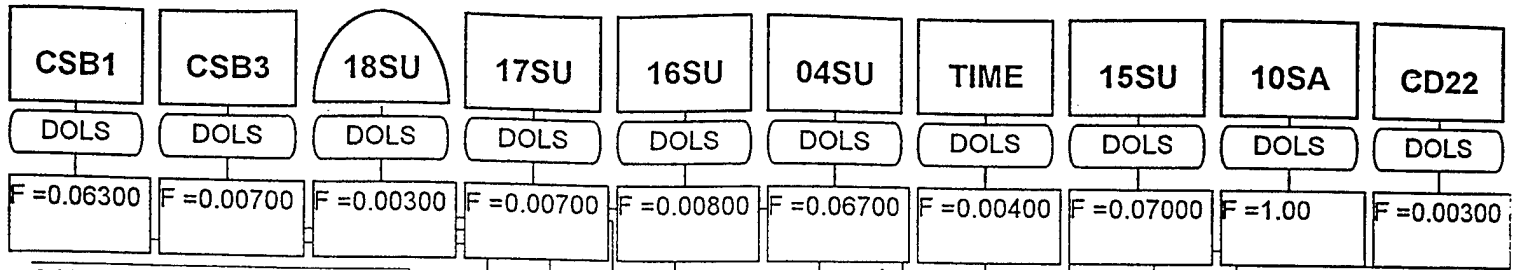

\$ CODE 10 COSTS  
231180.00

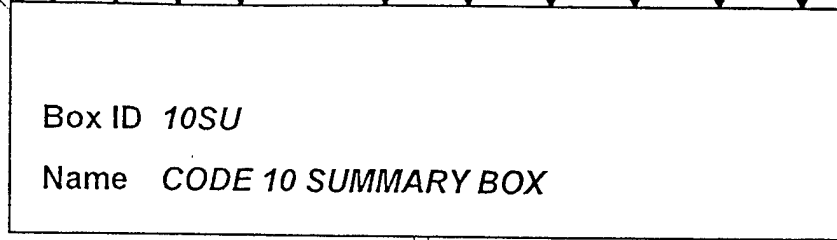

Capacity  
INFINITE

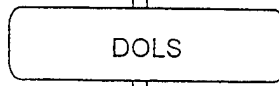

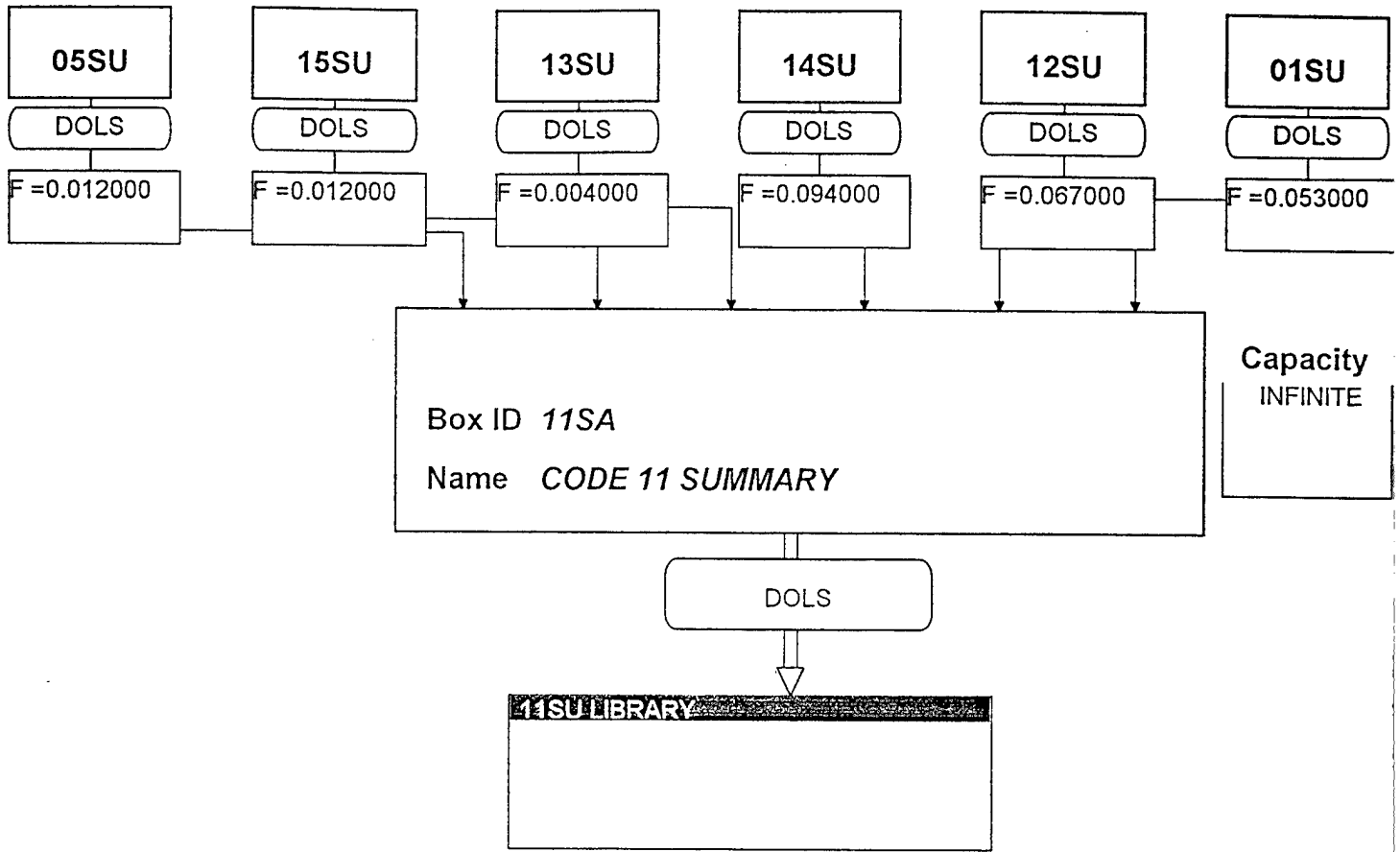

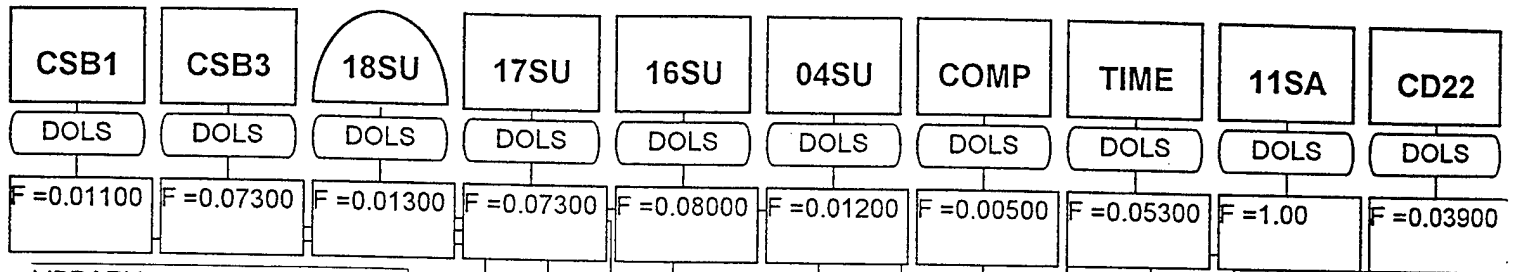

\$ LIBRARY  
2320899.0

Box ID 11SU  
Name LIBRARY

Capacity  
INFINITE

DOLS

**NMSA RESIDUAL SUMMARY**  
08SA CODE 08 SUMMARY  
07SA CODE 07 SUMMARY  
06SA CODE 06 SUMMARY

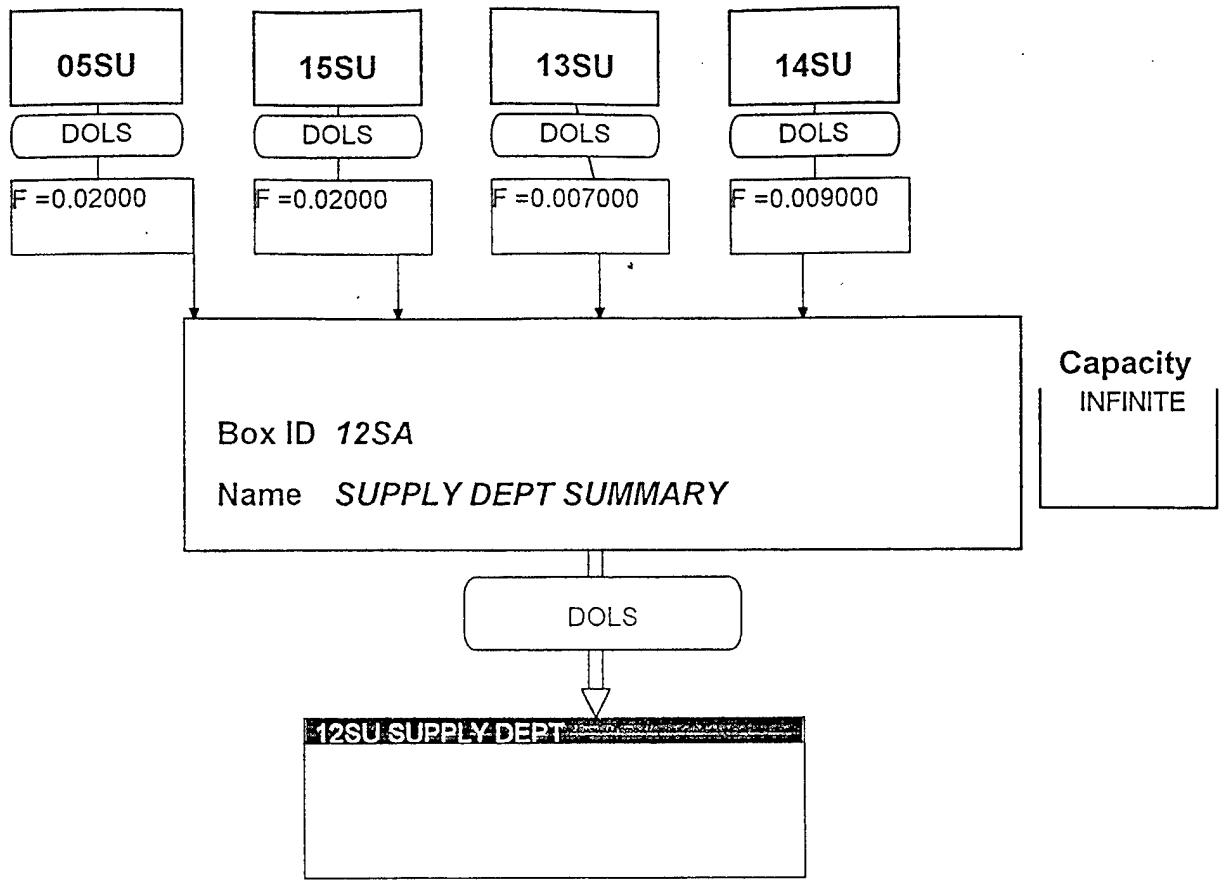



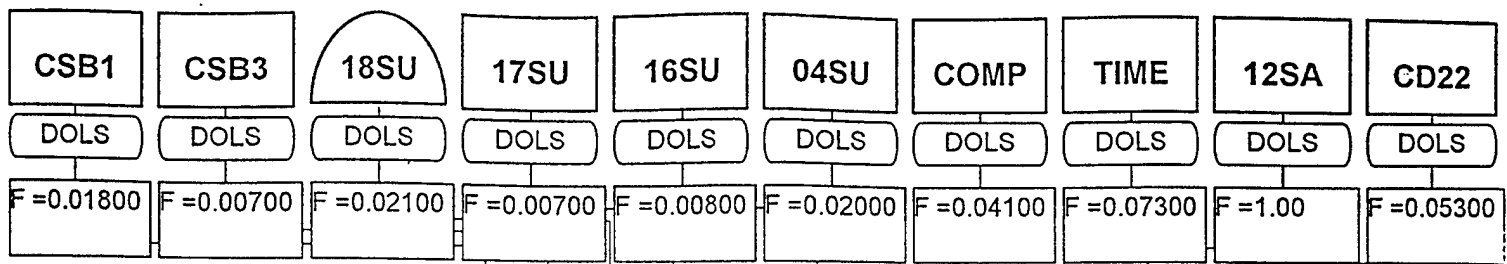

\$ SUPPLY DEPT  
1987403.0

Box ID 12SU  
Name SUPPLY DEPT

Capacity  
INFINITE

DOLS

- 10SA CODE 10 SUMMARY
- 09SA CODE 09 SUMMARY
- 08SA CODE 08 SUMMARY
- 07SA CODE 07 SUMMARY
- 06SA CODE 06 SUMMARY
- 03SA CODE 03 SUMMARY
- 01SA CODE 01 SUMMARY
- 00SA CODE 00 SUMMARY
- 11SA CODE 11 SUMMARY

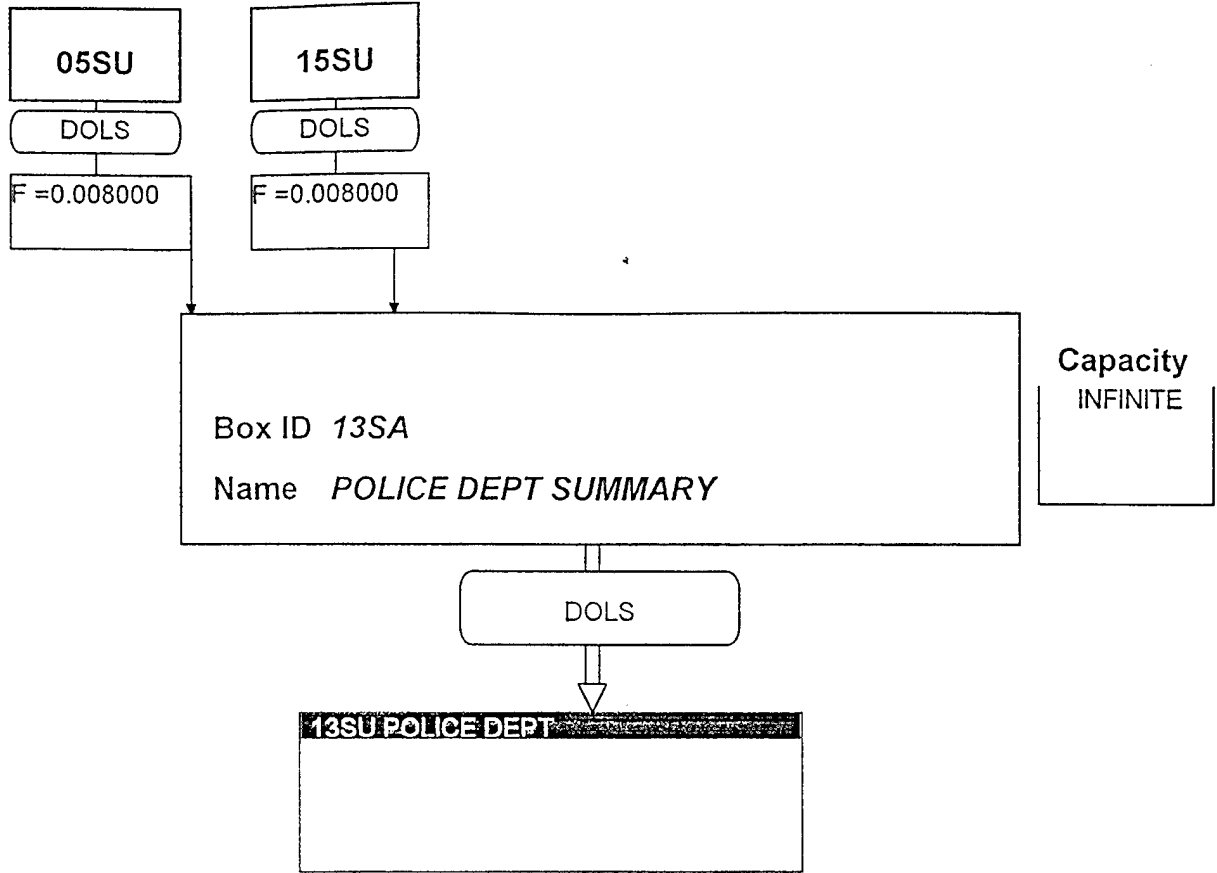

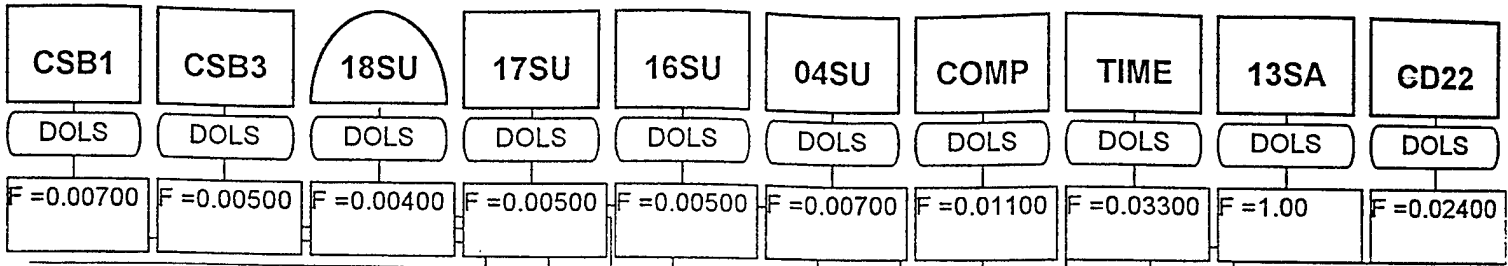

\$ POLICE DEPT  
657616.00

Box ID 13SU  
Name POLICE DEPT

Capacity  
INFINITE

DOLS

**NMSA RESIDUAL SUMMARY**  
 10SA CODE 10 SUMMARY  
 09SA CODE 09 SUMMARY  
 08SA CODE 08 SUMMARY  
 07SA CODE 07 SUMMARY  
 06SA CODE 06 SUMMARY  
 03SA CODE 03 SUMMARY  
 01SA CODE 01 SUMMARY  
 00SA CODE 00 SUMMARY  
 11SA CODE 11 SUMMARY  
 12SA SUPPLY DEPT SUMMARY  
 14SA FIRE DEPT SUMMARY

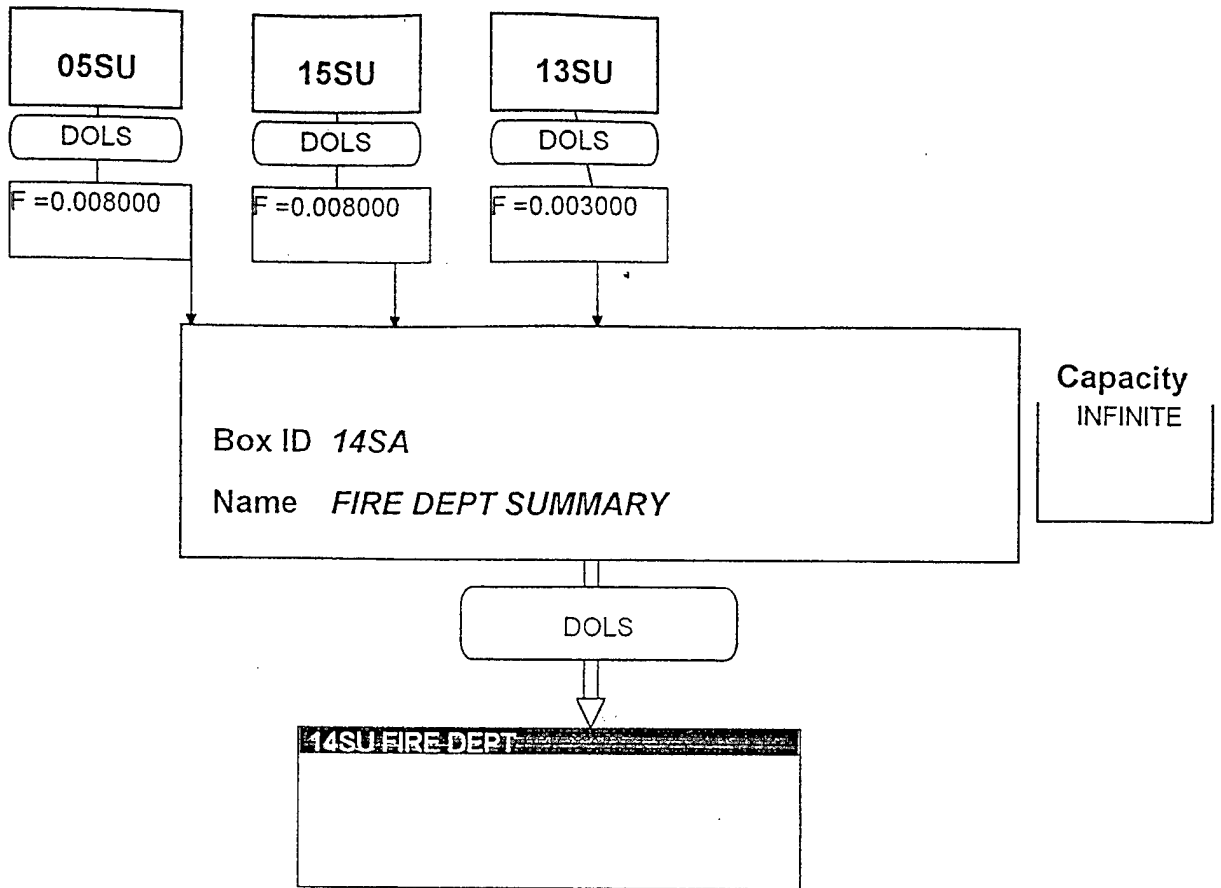

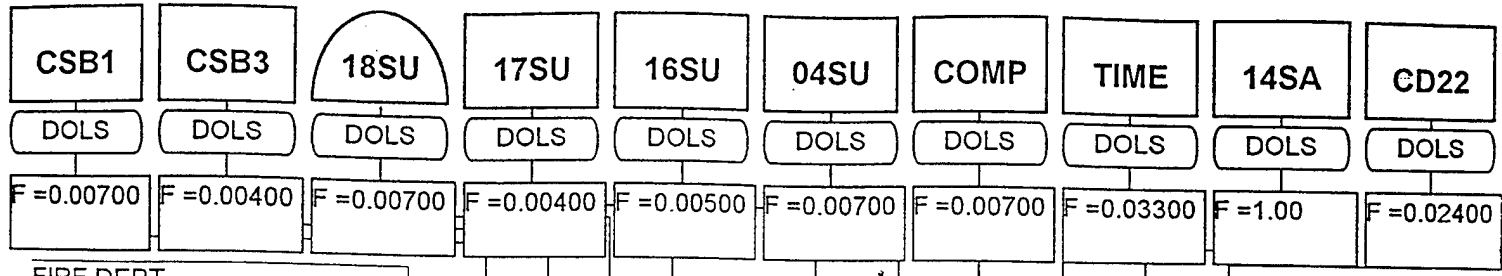

\$ FIRE DEPT  
859659.00

Box ID 14SU  
Name FIRE DEPT

Capacity  
INFINITE

DOLS

NMSA RESIDUAL SUMMARY
10SA CODE 10 SUMMARY
09SA CODE 09 SUMMARY
08SA CODE 08 SUMMARY
07SA CODE 07 SUMMARY
06SA CODE 06 SUMMARY
03SA CODE 03 SUMMARY
01SA CODE 01 SUMMARY
00SA CODE 00 SUMMARY
11SA CODE 11 SUMMARY
12SA SUPPLY DEPT SUMMARY

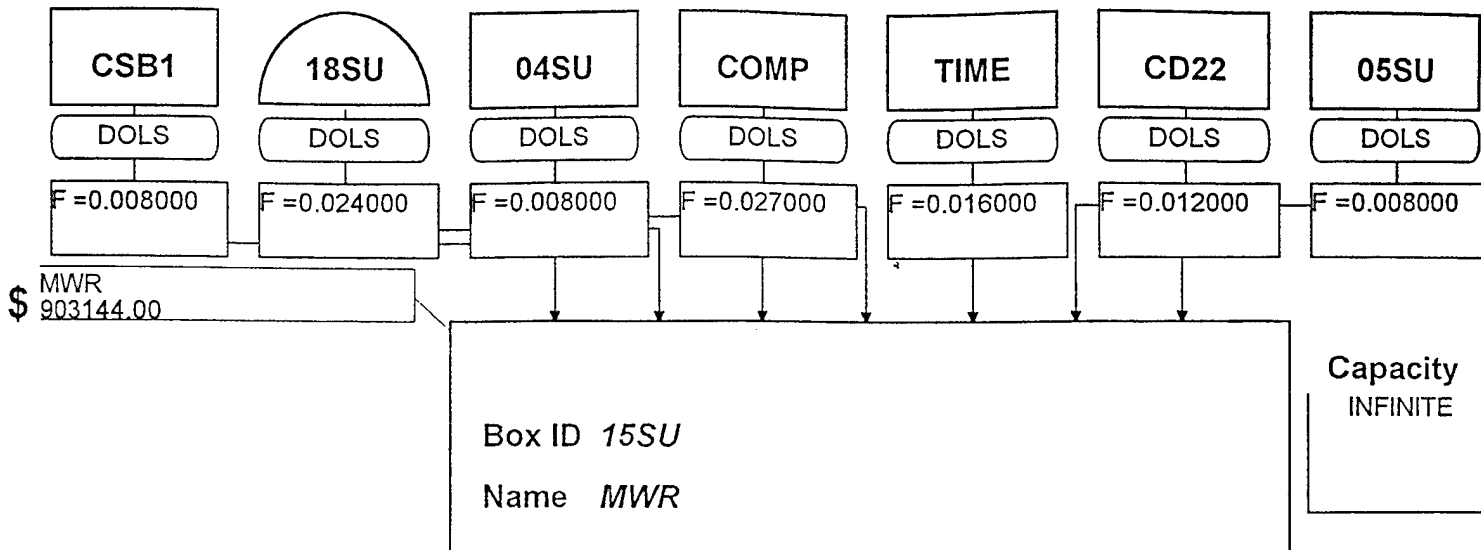

**10SU CODE 10 SUMMARY BOX**  
 NMSA RESIDUAL SUMMARY  
 09SA CODE 09 SUMMARY  
 08SA CODE 08 SUMMARY  
 07SA CODE 07 SUMMARY  
 06SA CODE 06 SUMMARY  
 03SA CODE 03 SUMMARY  
 01SA CODE 01 SUMMARY  
 00SA CODE 00 SUMMARY  
 11SA CODE 11 SUMMARY  
 12SA SUPPLY DEPT SUMMARY  
 14SA FIRE DEPT SUMMARY  
 13SA POLICE DEPT SUMMARY

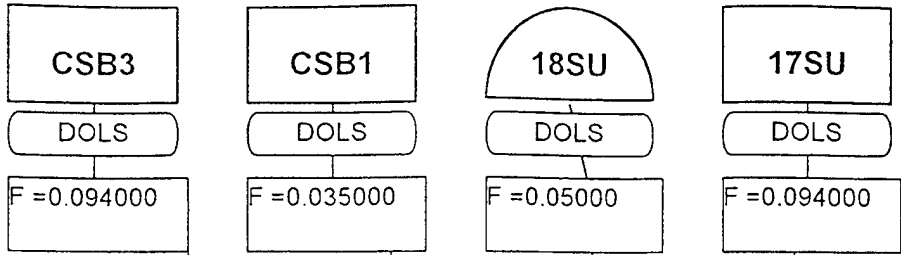

\$ PUBLIC WORKS  
7257729.0

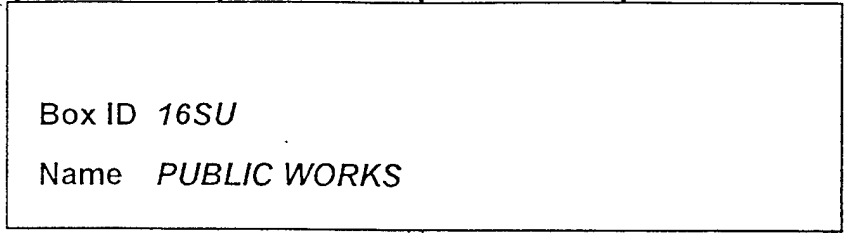

Capacity  
INFINITE

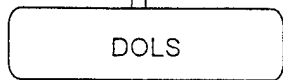

- ~~01SU NAVAL SUPPORT ACTIVITY~~
- COMP COMPTROLLER
  - TIME TIMEKEEPING
  - 13SU POLICE DEPT
  - 14SU FIRE DEPT
  - 05SU COMPUTER INFO SVCS
  - 12SU SUPPLY DEPT
  - 11SU LIBRARY
  - 00SU SUPERINTENDENT
  - 01SU PROVOST
  - 03SU DEAN OF STUDENTS
  - NMSU RESIDUAL SUMMARY
  - 06SU CODE 06 SUMMARY BOX
  - 07SU CODE 07 SUMMARY BOX
  - 08SU CODE 08 SUMMARY BOX
  - 09SU CODE 09 SUMMARY BOX
  - 10SU CODE 10 SUMMARY BOX
  - CD22 HRSC

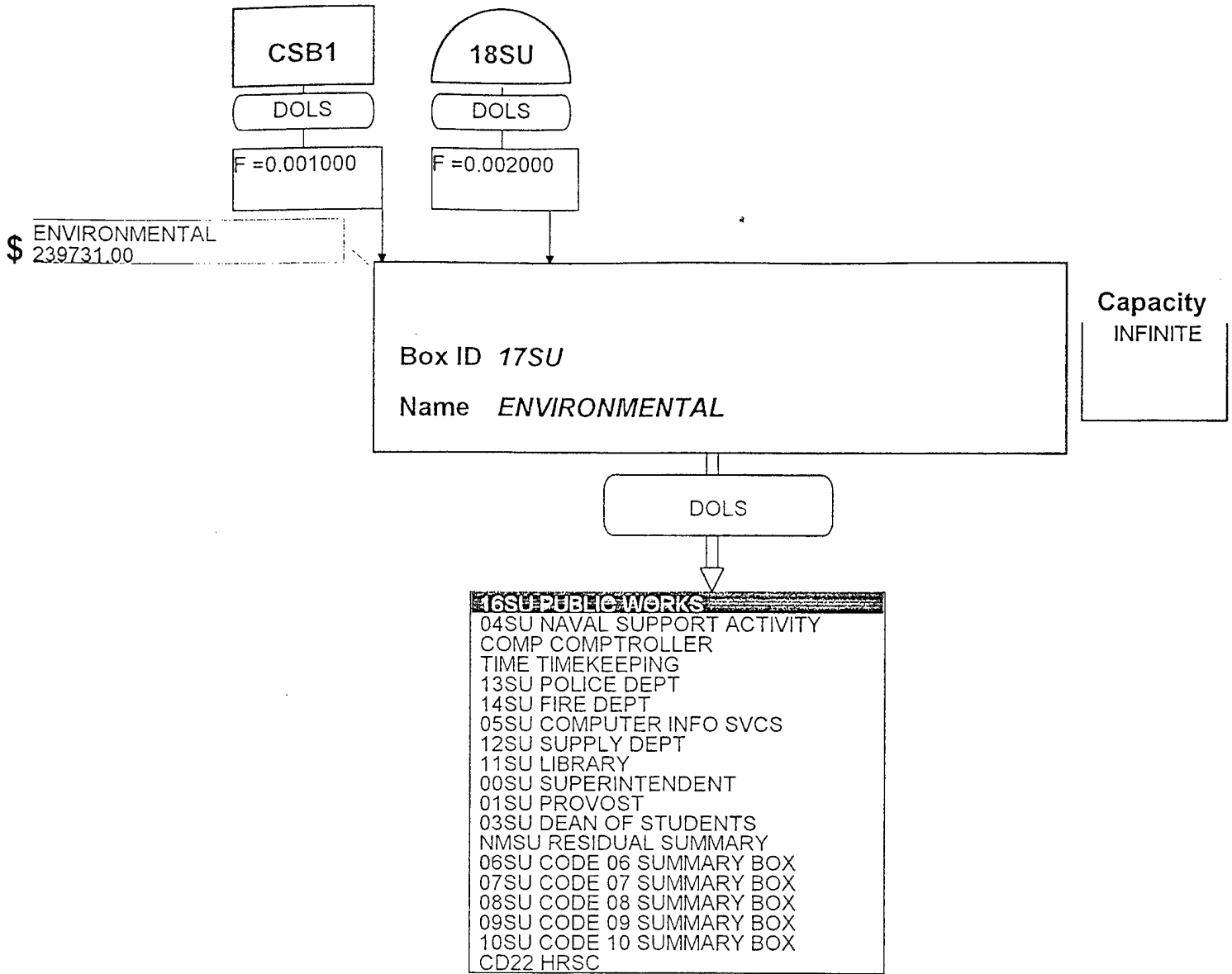



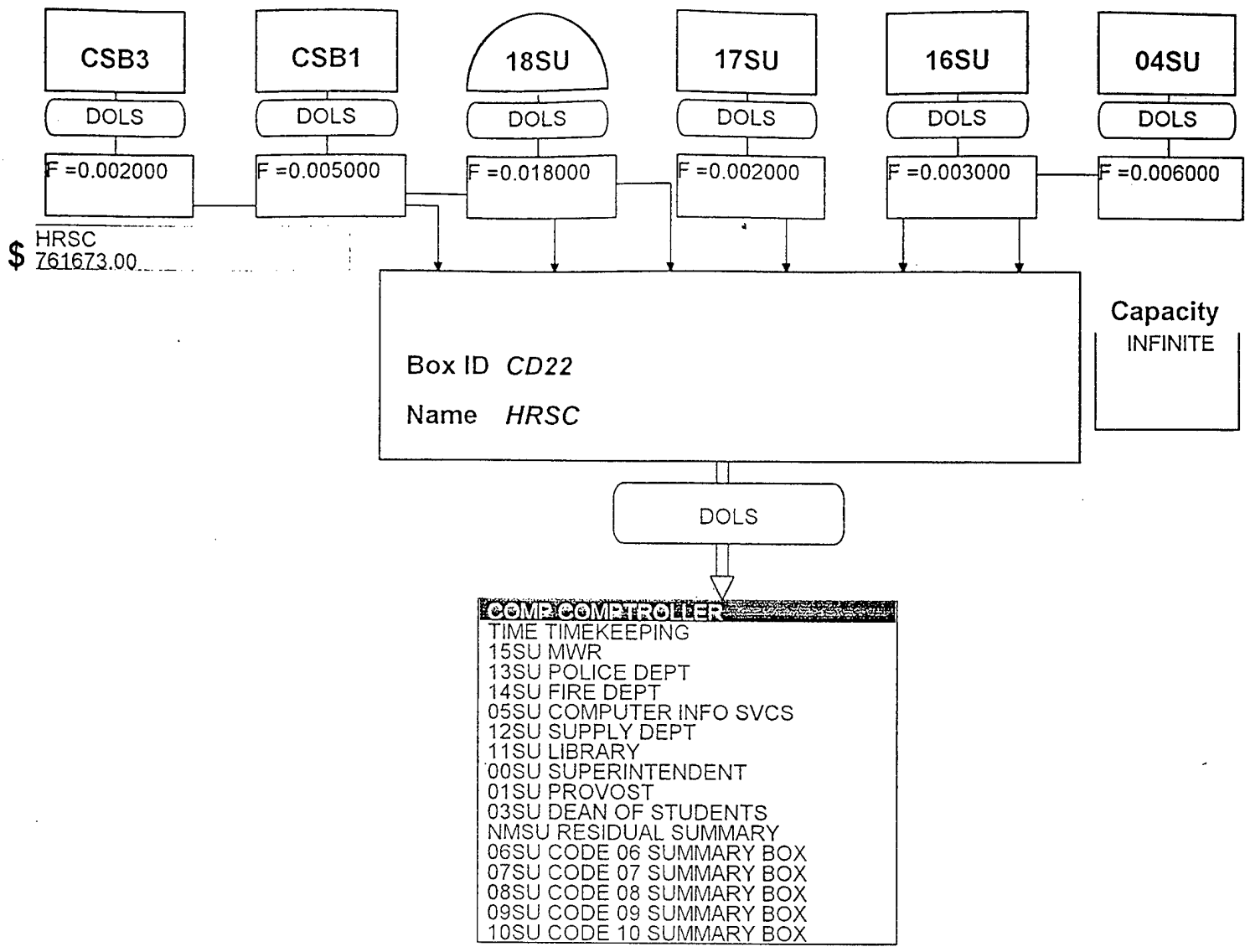

HRSC  
\$ 761673.00

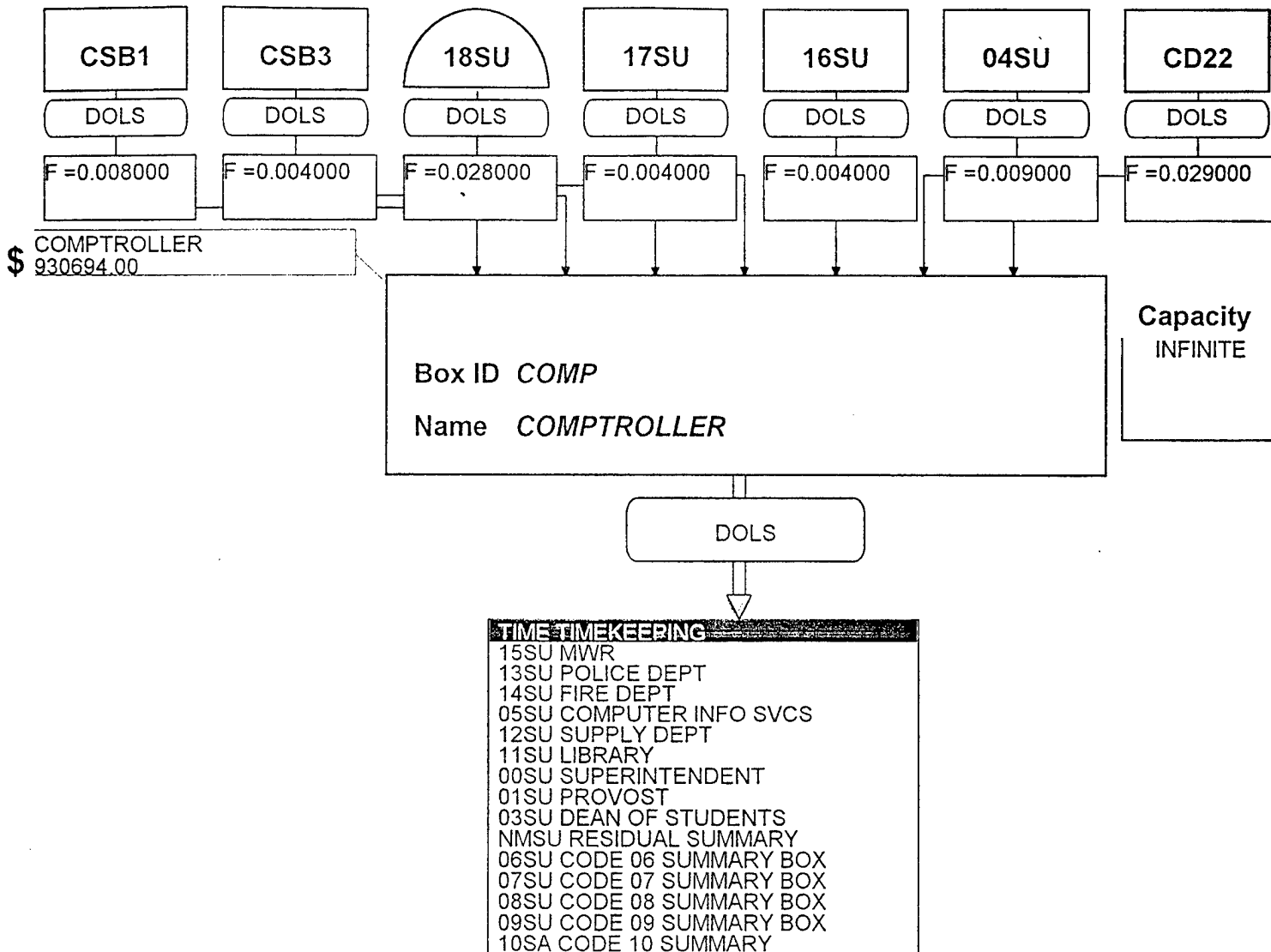

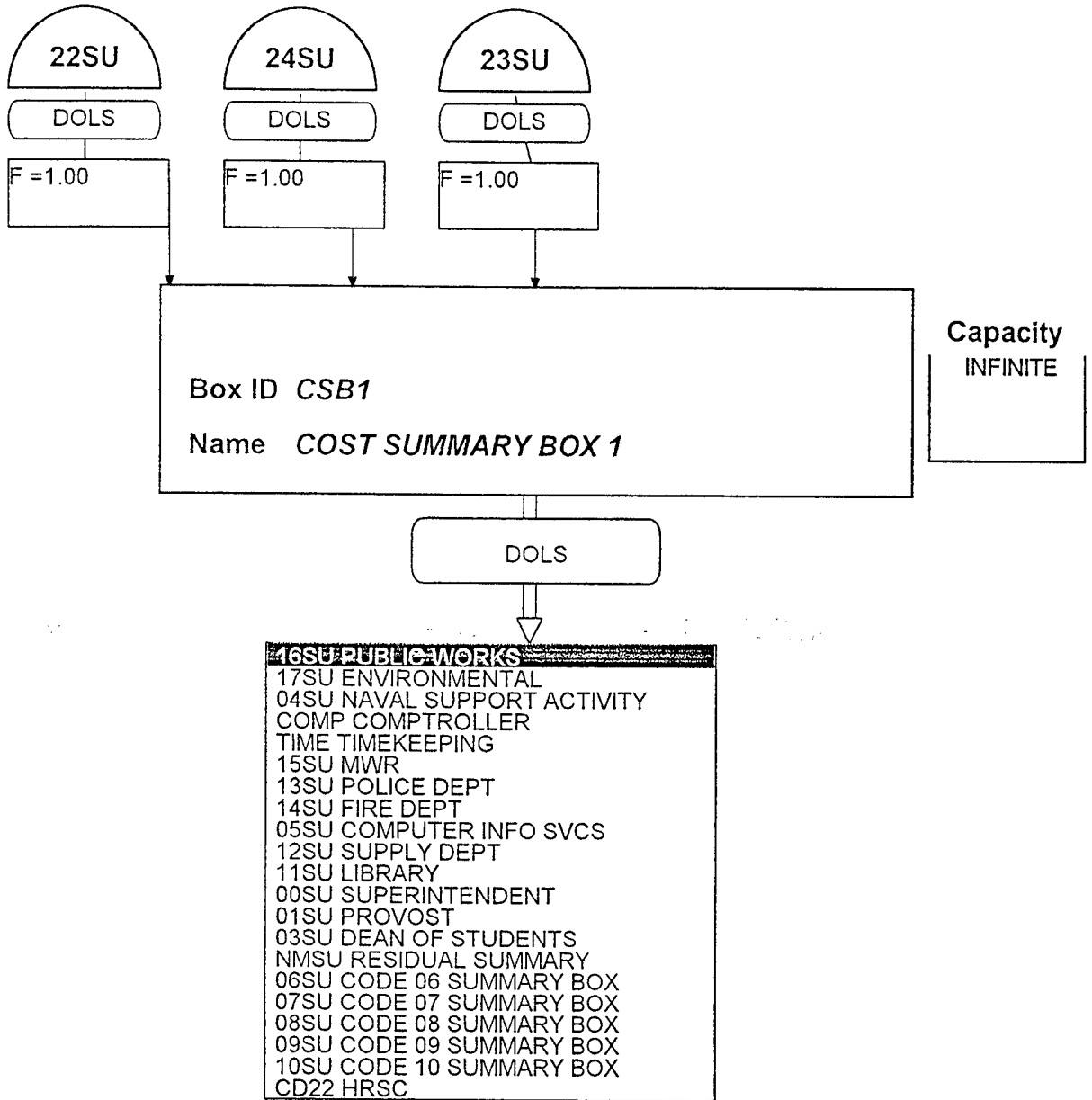

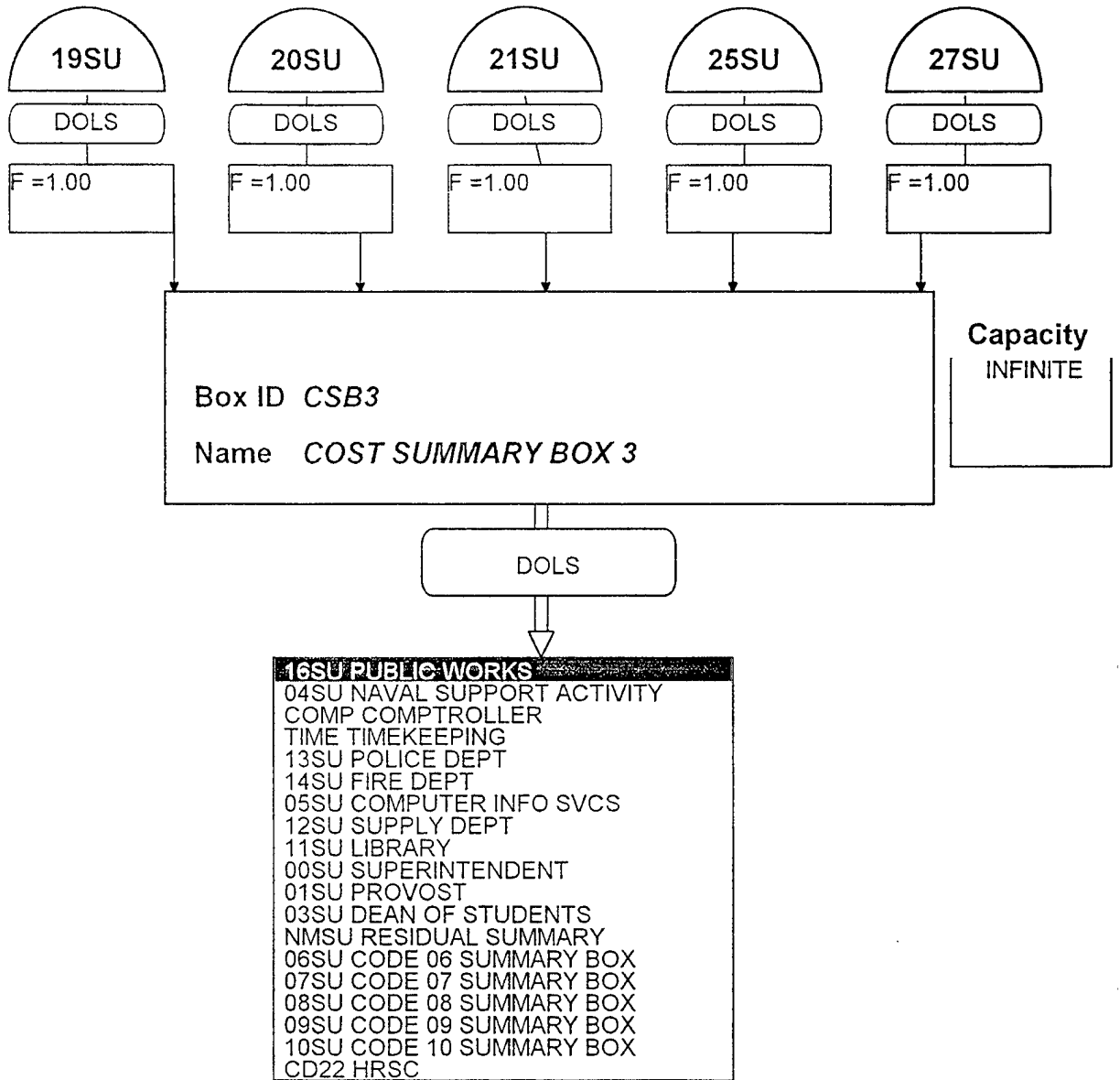

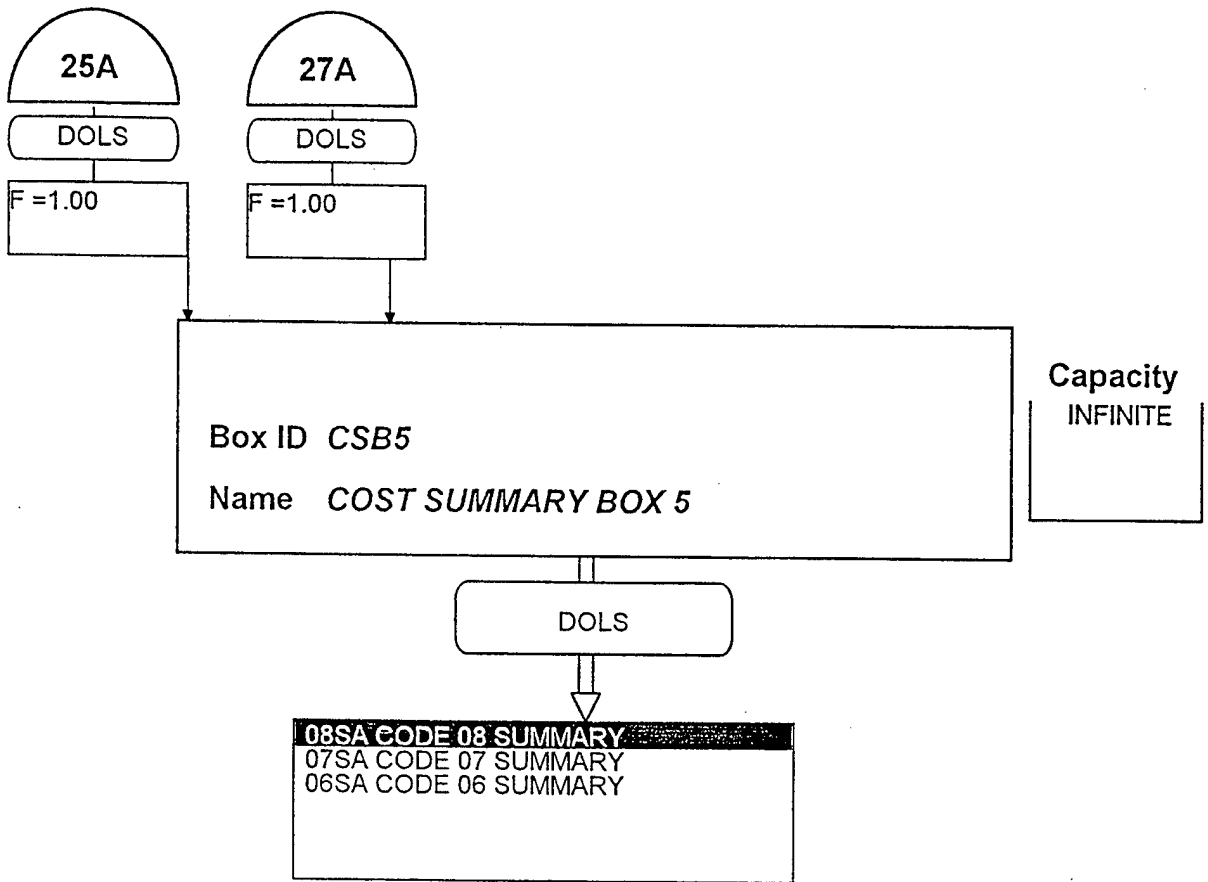

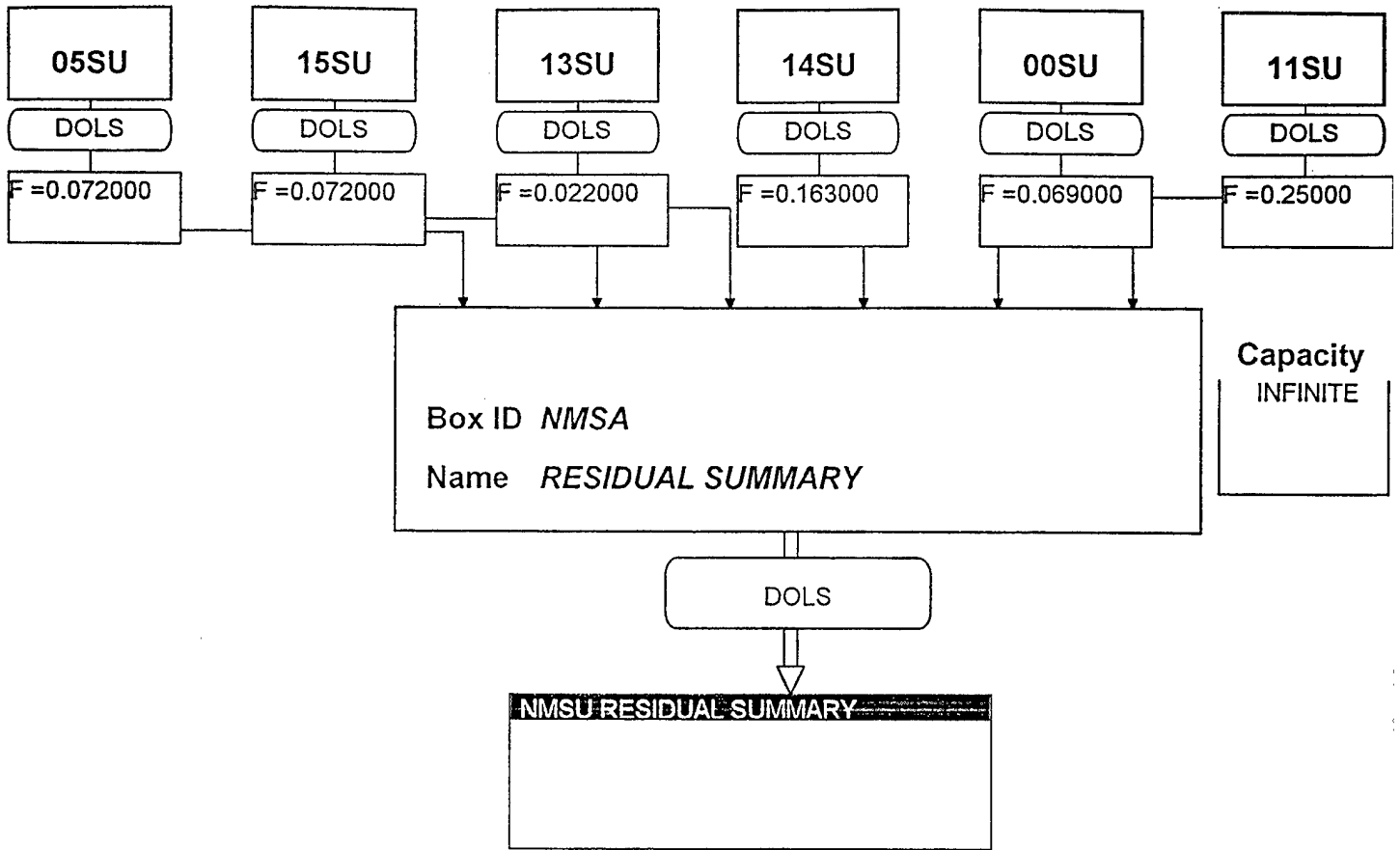

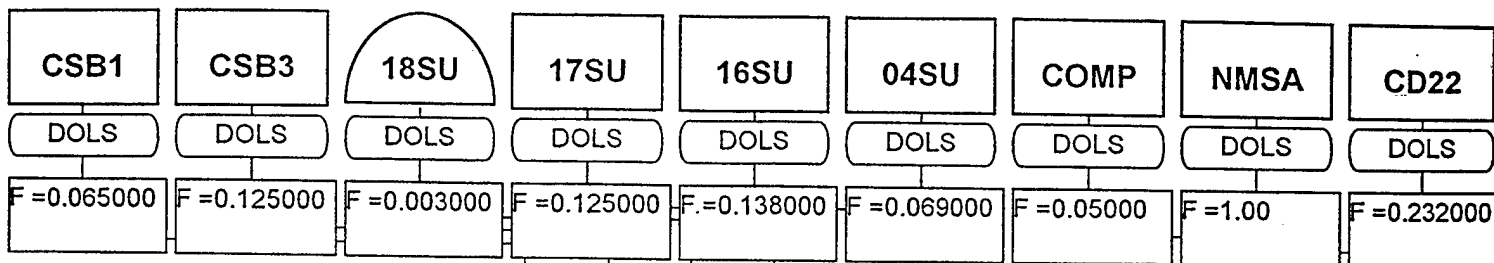

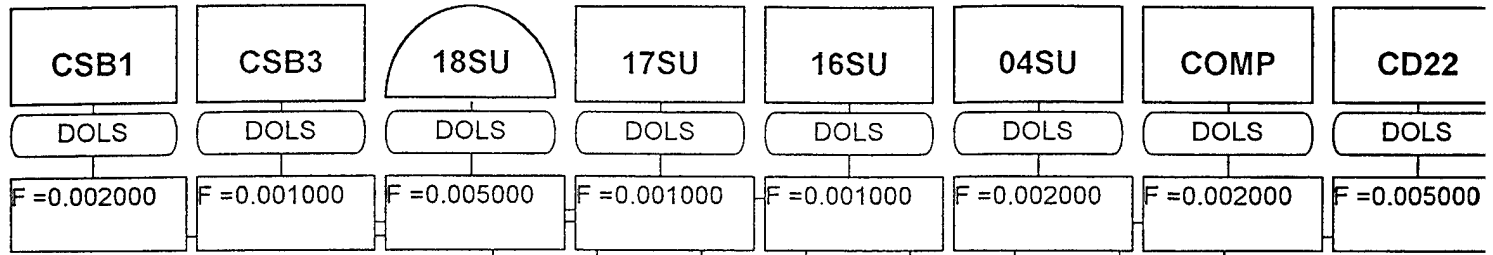

\$ TIMEKEEPING  
164240.00

Box ID *TIME*  
Name *TIMEKEEPING*

Capacity  
INFINITE

DOLS

- 15SU MWR**
- 13SU POLICE DEPT
  - 14SU FIRE DEPT
  - 05SU COMPUTER INFO SVCS
  - 12SU SUPPLY DEPT
  - 11SU LIBRARY
  - 00SU SUPERINTENDENT
  - 01SU PROVOST
  - 03SU DEAN OF STUDENTS
  - 06SU CODE 06 SUMMARY BOX
  - 07SU CODE 07 SUMMARY BOX
  - 08SU CODE 08 SUMMARY BOX
  - 09SU CODE 09 SUMMARY BOX
  - 10SU CODE 10 SUMMARY BOX





1998-1999

**APPENDIX O. FINANCIAL RESULTS FOR FY 96**

Total Financial Results [\$]  
 'NPS INDIRECT COST MODEL'

Category	Fixed	Variable	Total
101 ELECTRICITY	0.00	1131572.00	1131572.00
102 NATURAL GAS	0.00	105603.00	105603.00
103 MAIN GAS	0.00	187036.00	187036.00
104 CUSTODIAL NPS	0.00	1143169.00	1143169.00
105 GROUNDS MAINT NPS	0.00	187036.00	187036.00
106 CUSTODIAL LA MESA	0.00	2951.00	2951.00
107 GROUNDS MAINT LA MESA	0.00	151873.00	151873.00
108 WATER	0.00	110062.01	110062.01
109 SEWAGE	0.00	73833.01	73833.01
110 REFUSE	0.00	142924.02	142924.02
111 PHONES	0.00	845500.00	845500.00
120 PUBLIC WORKS	7257729.00	0.00	7257729.00
121 ENVIRONMENTAL	239731.00	0.00	239731.00
122 NAVAL SUPPORT ACTIVITY	3768170.00	0.00	3768170.00
123 COMPROLLER	930694.00	0.00	930694.00
124 TIMEKEEPING	164240.00	0.00	164240.00
125 HRSC	761673.00	0.00	761673.00
126 MWR	903144.00	0.00	903144.00
127 POLICE DEPT	657616.00	0.00	657616.00
128 FIRE DEPT	859659.00	0.00	859659.00
129 COMPUTER INFO SVCS	3645912.00	0.00	3645912.00
130 SUPPLY DEPT	1987403.00	0.00	1987403.00
131 LIBRARY	2320899.00	0.00	2320899.00
132 SUPERINTENDENT	1326812.00	0.00	1326812.00
133 PROVOST	1805222.00	0.00	1805222.00
134 DEAN OF STUDENTS	1820347.00	0.00	1820347.00
146 CODE 06 COSTS	2304257.00	0.00	2304257.00
147 CODE 07 COSTS	6270215.00	0.00	6270215.00
148 CODE 08 COSTS	5103595.00	0.00	5103595.00
149 CODE 09 COSTS	565382.00	0.00	565382.00
150 CODE 10 COSTS	231180.00	0.00	231180.00
=====			
Total Cost	42923880.0	4081559.04	47005439.0
=====			

+--- Total Model Summary ---+			
	Fixed	Variable	Total
Cost	42923880.00	4081559.04	47005439.04

Total Financial Results [\$]  
 'NPS INDIRECT COST MODEL QTR 1'

Category	Fixed	Variable	Total
101 ELECTRICITY	0.00	310145.00	310145.00
102 NATURAL GAS	0.00	51226.00	51226.00
103 MAIN GAS	0.00	25128.00	25128.00
104 CUSTODIAL NPS	0.00	285793.00	285793.00
105 GROUNDS MAINT NPS	0.00	46759.00	46759.00
106 CUSTODIAL LA MESA	0.00	738.00	738.00
107 GROUNDS MAINT LA MESA	0.00	37968.00	37968.00
108 WATER	0.00	27892.00	27892.00
109 SEWAGE	0.00	21535.00	21535.00
110 REFUSE	0.00	44229.01	44229.01
111 PHONES	0.00	105750.00	105750.00
120 PUBLIC WORKS	1500385.00	0.00	1500385.00
121 ENVIRONMENTAL	80790.00	0.00	80790.00
122 NAVAL SUPPORT ACTIVITY	997085.00	0.00	997085.00
123 COMPTRROLLER	231733.00	0.00	231733.00
124 TIMEKEEPING	40894.00	0.00	40894.00
125 HRSC	191367.00	0.00	191367.00
126 MWR	210335.00	0.00	210335.00
127 POLICE DEPT.	161734.00	0.00	161734.00
128 FIRE DEPT	210886.00	0.00	210886.00
129 COMPUTER INFO SVCS	1157377.00	0.00	1157377.00
130 SUPPLY DEPT	477586.00	0.00	477586.00
131 LIBRARY	810393.00	0.00	810393.00
132 SUPERINTENDENT	314390.00	0.00	314390.00
133 PROVOST	458117.00	0.00	458117.00
134 DEAN OF STUDENTS	436733.00	0.00	436733.00
146 CODE 06 COSTS	557522.00	0.00	557522.00
147 CODE 07 COSTS	1580731.00	0.00	1580731.00
148 CODE 08 COSTS	1262346.00	0.00	1262346.00
149 CODE 09 COSTS	151073.00	0.00	151073.00
150 CODE 10 COSTS	56338.00	0.00	56338.00
=====			=====
Total Cost	10887815.0	957163.01	11844978.0
=====			=====

```

+--- Total Model Summary -----+
|                               |
|           Fixed      Variable      Total      |
|                               |
| Cost           10887815.00    957163.01    11844978.01 |
+-----+-----+-----+-----+

```

Total Financial Results [\$]  
 'NPS INDIRECT COST MODEL QTR 2'

Category	Fixed	Variable	Total
101 ELECTRICITY	0.00	310145.00	310145.00
102 NATURAL GAS	0.00	51226.00	51226.00
103 MAIN GAS	0.00	25128.00	25128.00
104 CUSTODIAL NPS	0.00	285793.00	285793.00
105 GROUNDS MAINT NPS	0.00	46759.00	46759.00
106 CUSTODIAL LA MESA	0.00	738.00	738.00
107 GROUNDS MAINT LA MESA	0.00	37968.00	37968.00
108 WATER	0.00	27892.00	27892.00
109 SEWAGE	0.00	21535.00	21535.00
110 REFUSE	0.00	44229.01	44229.01
111 PHONES	0.00	105750.00	105750.00
120 PUBLIC WORKS	1487119.00	0.00	1487119.00
121 ENVIRONMENTAL	81588.00	0.00	81588.00
122 NAVAL SUPPORT ACTIVITY	1006004.00	0.00	1006004.00
123 COMPTROLLER	236398.00	0.00	236398.00
124 TIMEKEEPING	41717.00	0.00	41717.00
125 HRSC	195315.00	0.00	195315.00
126 MWR	212771.00	0.00	212771.00
127 POLICE DEPT	165786.00	0.00	165786.00
128 FIRE DEPT	216300.00	0.00	216300.00
129 COMPUTER INFO SVCS	1034880.00	0.00	1034880.00
130 SUPPLY DEPT	486717.00	0.00	486717.00
131 LIBRARY	737447.00	0.00	737447.00
132 SUPERINTENDENT	316580.00	0.00	316580.00
133 PROVOST	471801.00	0.00	471801.00
134 DEAN OF STUDENTS	447000.00	0.00	447000.00
146 CODE 06 COSTS	557082.00	0.00	557082.00
147 CODE 07 COSTS	1583081.00	0.00	1583081.00
148 CODE 08 COSTS	1269514.00	0.00	1269514.00
149 CODE 09 COSTS	131495.00	0.00	131495.00
150 CODE 10 COSTS	57355.00	0.00	57355.00
=====			
Total Cost	10735950.0	957163.01	11693113.0
=====			

+--- Total Model Summary -----+			
	Fixed	Variable	Total
Cost	10735950.00	957163.01	11693113.01

Total Financial Results [\$]  
 'NPS INDIRECT COST MODEL QTR 3'

Category	Fixed	Variable	Total
101 ELECTRICITY	0.00	249613.61	249613.61
102 NATURAL GAS	0.00	1574.47	1574.47
103 MAIN GAS	0.00	25103.62	25103.62
104 CUSTODIAL NPS	0.00	285515.75	285515.75
105 GROUNDS MAINT NPS	0.00	46713.64	46713.64
106 CUSTODIAL LA MESA	0.00	738.00	738.00
107 GROUNDS MAINT LA MESA	0.00	37968.00	37968.00
108 WATER	0.00	47853.38	47853.38
109 SEWAGE	0.00	18451.98	18451.98
110 REFUSE	0.00	22660.60	22660.60
111 PHONES	0.00	423427.93	423427.93
120 PUBLIC WORKS	1507316.00	0.00	1507316.00
121 ENVIRONMENTAL	19348.00	0.00	19348.00
122 NAVAL SUPPORT ACTIVITY	875890.00	0.00	875890.00
123 COMPTROLLER	230557.00	0.00	230557.00
124 TIMEKEEPING	40687.00	0.00	40687.00
125 HRSC	180212.00	0.00	180212.00
126 MWR	221553.00	0.00	221553.00
127 POLICE DEPT	163244.00	0.00	163244.00
128 FIRE DEPT	215727.00	0.00	215727.00
129 COMPUTER INFO SVCS	728281.00	0.00	728281.00
130 SUPPLY DEPT	483021.00	0.00	483021.00
131 LIBRARY	377520.00	0.00	377520.00
132 SUPERINTENDENT	352316.00	0.00	352316.00
133 PROVOST	450746.00	0.00	450746.00
134 DEAN OF STUDENTS	471947.00	0.00	471947.00
146 CODE 06 COSTS	562172.00	0.00	562172.00
147 CODE 07 COSTS	1481623.00	0.00	1481623.00
149 CODE 09 COSTS	106983.00	0.00	106983.00
150 CODE 10 COSTS	55725.00	0.00	55725.00
=====			=====
Total Cost	8524868.00	1159620.97	9684488.97
=====			=====

```

+--- Total Model Summary -----+
|           Fixed   Variable   Total   |
| Cost           8524868.00  1159620.97  9684488.97 |
+-----+

```

Total Financial Results [\$]  
 'NPS INDIRECT COST MODEL QTR 4'

Category	Fixed	Variable	Total
101 ELECTRICITY	0.00	261427.00	261427.00
102 NATURAL GAS	0.00	1576.00	1576.00
103 MAIN GAS	0.00	25128.00	25128.00
104 CUSTODIAL NPS	0.00	285793.00	285793.00
105 GROUNDS MAINT NPS	0.00	46759.00	46759.00
106 CUSTODIAL LA MESA	0.00	738.00	738.00
107 GROUNDS MAINT LA MESA	0.00	37968.00	37968.00
108 WATER	0.00	6409.00	6409.00
109 SEWAGE	0.00	12306.00	12306.00
110 REFUSE	0.00	31798.00	31798.00
111 PHONES	0.00	210000.00	210000.00
120 PUBLIC WORKS	2663491.00	0.00	2663491.00
121 ENVIRONMENTAL	58006.00	0.00	58006.00
122 NAVAL SUPPORT ACTIVITY	889198.00	0.00	889198.00
123 COMPTROLLER	232009.00	0.00	232009.00
124 TIMEKEEPING	40943.00	0.00	40943.00
125 HRSC	194769.00	0.00	194769.00
126 MWR	258489.00	0.00	258489.00
127 POLICE DEPT	166853.00	0.00	166853.00
128 FIRE DEPT	216745.00	0.00	216745.00
129 COMPUTER INFO SVCS	1139002.00	0.00	1139002.00
130 SUPPLY DEPT	540088.00	0.00	540088.00
131 LIBRARY	395539.00	0.00	395539.00
132 SUPERINTENDENT	343559.00	0.00	343559.00
133 PROVOST	424559.00	0.00	424559.00
134 DEAN OF STUDENTS	646673.00	0.00	646673.00
146 CODE 06 COSTS	627489.00	0.00	627489.00
147 CODE 07 COSTS	1624819.00	0.00	1624819.00
148 CODE 08 COSTS	1273830.00	0.00	1273830.00
149 CODE 09 COSTS	175835.00	0.00	175835.00
150 CODE 10 COSTS	61770.00	0.00	61770.00
=====			=====
Total Cost	11973666.0	919902.01	12893568.0
=====			=====

+--- Total Model Summary -----+			
	Fixed	Variable	Total
Cost	11973666.00	919902.01	12893568.01



Financial Results [\$]

Box MSSC CODE 06 COSTS, Volume : 1 ACTIVITY

Category	Fixed	Variable	Total
101 ELECTRICITY	0.00	153781.62	153781.62
102 NATURAL GAS	0.00	14351.54	14351.54
103 MAIN GAS	0.00	25418.36	25418.36
104 CUSTODIAL NPS	0.00	155357.66	155357.66
105 GROUNDS MAINT NPS	0.00	25418.36	25418.36
106 CUSTODIAL LA MESA	0.00	1171.55	1171.55
107 GROUNDS MAINT LA MESA	0.00	60293.58	60293.58
108 WATER	0.00	32356.68	32356.68
109 SEWAGE	0.00	21705.86	21705.86
110 REFUSE	0.00	42017.65	42017.65
111 PHONES	0.00	179899.83	179899.83
120 PUBLIC WORKS	981526.86	0.00	981526.86
121 ENVIRONMENTAL	32579.65	0.00	32579.65
122 NAVAL SUPPORT ACTIVITY	1127313.15	0.00	1127313.15
123 COMPTROLLER	204991.34	0.00	204991.34
124 TIMEKEEPING	40371.36	0.00	40371.36
125 HRSC	142967.48	0.00	142967.48
126 MWR	271936.30	0.00	271936.30
127 POLICE DEPT	234192.07	0.00	234192.07
128 FIRE DEPT	92588.92	0.00	92588.92
129 COMPUTER INFO SVCS	1099273.08	0.00	1099273.08
130 SUPPLY DEPT	479573.38	0.00	479573.38
131 LIBRARY	689306.98	0.00	689306.98
132 SUPERINTENDENT	301887.62	0.00	301887.62
133 PROVOST	566372.15	0.00	566372.15
134 DEAN OF STUDENTS	722677.79	0.00	722677.79
146 CODE 06 COSTS	2304257.00	0.00	2304257.00
=====			
Total Cost	9291815.12	711772.68	10003587.8
Unit	9291815.11	711772.683	10003587.8
=====			

+--- Box Summary ---+			
	Fixed	Variable	Total
Cost	9291815.12	711772.68	10003587.80
Unit			10003587.800

		Financial Results [\$]		
Box ECSC CODE 07 COSTS, Volume : 1		ACTIVITY		
Category		Fixed	Variable	Total
101	ELECTRICITY	0.00	452063.26	452063.26
102	NATURAL GAS	0.00	42188.42	42188.42
103	MAIN GAS	0.00	74720.92	74720.92
104	CUSTODIAL NPS	0.00	456696.27	456696.27
105	GROUNDS MAINT NPS	0.00	74720.92	74720.92
106	CUSTODIAL LA MESA	0.00	725.95	725.95
107	GROUNDS MAINT LA MESA	0.00	37360.76	37360.76
108	WATER	0.00	27562.28	27562.28
109	SEWAGE	0.00	18489.63	18489.63
110	REFUSE	0.00	35791.74	35791.74
111	PHONES	0.00	349545.87	349545.87
120	PUBLIC WORKS	2904901.19	0.00	2904901.19
121	ENVIRONMENTAL	95772.59	0.00	95772.59
122	NAVAL SUPPORT ACTIVITY	925636.06	0.00	925636.06
123	COMPTROLLER	264189.35	0.00	264189.35
124	TIMEKEEPING	59993.79	0.00	59993.79
125	HRSC	211711.95	0.00	211711.95
126	MWR	220159.43	0.00	220159.43
127	POLICE DEPT	169496.69	0.00	169496.69
128	FIRE DEPT	365543.47	0.00	365543.47
129	COMPUTER INFO SVCS	888582.31	0.00	888582.31
130	SUPPLY DEPT	751622.00	0.00	751622.00
131	LIBRARY	429366.32	0.00	429366.32
132	SUPERINTENDENT	274193.75	0.00	274193.75
133	PROVOST	555656.36	0.00	555656.36
134	DEAN OF STUDENTS	447805.37	0.00	447805.37
147	CODE 07 COSTS	6270215.00	0.00	6270215.00
Total Cost		14834845.6	1569866.03	16404711.6
Unit		14834845.6	1569866.02	16404711.6

+--- Box Summary ---+			
	Fixed	Variable	Total
Cost	14834845.62	1569866.03	16404711.65
Unit			16404711.646

Financial Results [\$]

Box OASC CODE 08 COSTS, Volume : 1 ACTIVITY

Category	Fixed	Variable	Total
101 ELECTRICITY	0.00	295758.64	295758.64
102 NATURAL GAS	0.00	27601.42	27601.42
103 MAIN GAS	0.00	48885.54	48885.54
104 CUSTODIAL NPS	0.00	298789.74	298789.74
105 GROUNDS MAINT NPS	0.00	48885.54	48885.54
106 CUSTODIAL LA MESA	0.00	1053.51	1053.51
107 GROUNDS MAINT LA MESA	0.00	54218.66	54218.66
108 WATER	0.00	32864.50	32864.50
109 SEWAGE	0.00	22046.52	22046.52
110 REFUSE	0.00	42677.08	42677.08
111 PHONES	0.00	251127.35	251127.35
120 PUBLIC WORKS	1892719.72	0.00	1892719.72
121 ENVIRONMENTAL	62658.42	0.00	62658.42
122 NAVAL SUPPORT ACTIVITY	1128754.41	0.00	1128754.41
123 COMPROLLER	340261.69	0.00	340261.69
124 TIMEKEEPING	52943.74	0.00	52943.74
125 HRSC	189688.24	0.00	189688.24
126 MWR	270785.46	0.00	270785.46
127 POLICE DEPT	222155.73	0.00	222155.73
128 FIRE DEPT	218393.87	0.00	218393.87
129 COMPUTER INFO SVCS	1090944.22	0.00	1090944.22
130 SUPPLY DEPT	648997.07	0.00	648997.07
131 LIBRARY	622000.95	0.00	622000.95
132 SUPERINTENDENT	294557.74	0.00	294557.74
133 PROVOST	563597.54	0.00	563597.54
134 DEAN OF STUDENTS	649863.87	0.00	649863.87
148 CODE 08 COSTS	5103595.00	0.00	5103595.00
=====			
Total Cost	13351917.6	1123908.52	14475826.1
Unit	13351917.6	1123908.51	14475826.1
=====			

```

+--- Box Summary -----+
|           Fixed      Variable      Total           |
| Cost           13351917.67  1123908.52  14475826.19 |
| Unit                                     14475826.190 |
+-----+
  
```

Financial Results [\$]

Category	Box RESC CODE 09 COSTS, Volume : 1	ACTIVITY	Fixed	Variable	Total
101 ELECTRICITY			0.00	15824.39	15824.39
102 NATURAL GAS			0.00	1476.80	1476.80
103 MAIN GAS			0.00	2615.59	2615.59
104 CUSTODIAL NPS			0.00	15986.57	15986.57
105 GROUNDS MAINT NPS			0.00	2615.59	2615.59
108 WATER			0.00	691.29	691.29
109 SEWAGE			0.00	463.74	463.74
110 REFUSE			0.00	897.69	897.69
111 PHONES			0.00	19624.95	19624.95
120 PUBLIC WORKS			101987.51	0.00	101987.51
121 ENVIRONMENTAL			3352.50	0.00	3352.50
122 NAVAL SUPPORT ACTIVITY			25979.05	0.00	25979.05
123 COMPTROLLER			36942.59	0.00	36942.59
124 TIMEKEEPING			3907.58	0.00	3907.58
125 HRSC			14494.95	0.00	14494.95
126 MWR			5643.51	0.00	5643.51
127 POLICE DEPT			1885.39	0.00	1885.39
128 FIRE DEPT			12898.61	0.00	12898.61
129 COMPUTER INFO SVCS			22964.59	0.00	22964.59
130 SUPPLY DEPT			53900.41	0.00	53900.41
132 SUPERINTENDENT			185818.69	0.00	185818.69
133 PROVOST			95676.76	0.00	95676.76
149 CODE 09 COSTS			565382.00	0.00	565382.00
Total Cost			1130834.15	60196.60	1191030.75
Unit			1130834.15	60196.6011	1191030.75

+--- Box Summary ---+			
	Fixed	Variable	Total
Cost	1130834.15	60196.60	1191030.75
Unit			1191030.7514

Financial Results [\\$]

Box SASC CODE 10 COSTS, Volume : 1 ACTIVITY

Category	Fixed	Variable	Total
101 ELECTRICITY	0.00	20500.25	20500.25
102 NATURAL GAS	0.00	1913.17	1913.17
103 MAIN GAS	0.00	3388.46	3388.46
104 CUSTODIAL NPS	0.00	20710.35	20710.35
105 GROUNDS MAINT NPS	0.00	3388.46	3388.46
108 WATER	0.00	7554.74	7554.74
109 SEWAGE	0.00	5067.95	5067.95
110 REFUSE	0.00	9810.41	9810.41
111 PHONES	0.00	14679.09	14679.09
120 PUBLIC WORKS	133500.27	0.00	133500.27
121 ENVIRONMENTAL	4343.11	0.00	4343.11
122 NAVAL SUPPORT ACTIVITY	264778.00	0.00	264778.00
123 COMPTROLLER	23752.81	0.00	23752.81
124 TIMEKEEPING	2184.14	0.00	2184.14
125 HRSC	8101.36	0.00	8101.36
126 MWR	64434.47	0.00	64434.47
127 POLICE DEPT	14129.38	0.00	14129.38
128 FIRE DEPT	9228.56	0.00	9228.56
129 COMPUTER INFO SVCS	258551.26	0.00	258551.26
130 SUPPLY DEPT	15487.83	0.00	15487.83
132 SUPERINTENDENT	176466.00	0.00	176466.00
150 CODE 10 COSTS	231180.00	0.00	231180.00
=====			
Total Cost	1206137.18	87012.87	1293150.05
Unit	1206137.18	87012.8732	1293150.05
=====			

```

+--- Box Summary -----+
|           Fixed      Variable      Total      |
| Cost           1206137.18      87012.87      1293150.05 |
| Unit                                     1293150.0540 |
+-----+
  
```

Financial Results [\$]			
Box NMC RESIDUAL COSTS, Volume : 1 ACTIVITY			
Category	Fixed	Variable	Total
101 ELECTRICITY	0.00	193643.81	193643.81
102 NATURAL GAS	0.00	18071.64	18071.64
103 MAIN GAS	0.00	32007.12	32007.12
104 CUSTODIAL NPS	0.00	195628.38	195628.38
105 GROUNDS MAINT NPS	0.00	32007.12	32007.12
108 WATER	0.00	9032.52	9032.52
109 SEWAGE	0.00	6059.29	6059.29
110 REFUSE	0.00	11729.42	11729.42
111 PHONES	0.00	30622.92	30622.92
120 PUBLIC WORKS	1243093.42	0.00	1243093.42
121 ENVIRONMENTAL	41024.72	0.00	41024.72
122 NAVAL SUPPORT ACTIVITY	295708.90	0.00	295708.90
123 COMPTROLLER	60556.36	0.00	60556.36
124 TIMEKEEPING	4839.42	0.00	4839.42
125 HRSC	194708.98	0.00	194708.98
126 MWR	70184.86	0.00	70184.86
127 POLICE DEPT	15756.72	0.00	15756.72
128 FIRE DEPT	161005.62	0.00	161005.62
129 COMPUTER INFO SVCS	285596.66	0.00	285596.66
130 SUPPLY DEPT	37822.28	0.00	37822.28
131 LIBRARY	580224.75	0.00	580224.75
132 SUPERINTENDENT	93888.20	0.00	93888.20
133 PROVOST	23919.19	0.00	23919.19
=====			
Total Cost	3108330.07	528802.24	3637132.31
Unit	3108330.07	528802.237	3637132.31
=====			

+--- Box Summary ---+			
	Fixed	Variable	Total
Cost	3108330.07	528802.24	3637132.31
Unit			3637132.3127







**APPENDIX P. MANAGEMENT AND SECURITY STUDIES FY 96  
QUARTERLY FINANCIAL RESULTS**

Financial Results [\\$]			
Category	Box MSSC CODE 06 COSTS, Volume : 1	ACTIVITY	
	Fixed	Variable	Total
101 ELECTRICITY	0.00	42547.28	42547.28
102 NATURAL GAS	0.00	7027.45	7027.45
103 MAIN GAS	0.00	3447.19	3447.19
104 CUSTODIAL NPS	0.00	39206.55	39206.55
105 GROUNDS MAINT NPS	0.00	6414.64	6414.64
106 CUSTODIAL LA MESA	0.00	292.99	292.99
107 GROUNDS MAINT LA MESA	0.00	15073.30	15073.30
108 WATER	0.00	8209.52	8209.52
109 SEWAGE	0.00	6338.45	6338.45
110 REFUSE	0.00	13018.03	13018.03
111 PHONES	0.00	22611.43	22611.43
120 PUBLIC WORKS	204830.05	0.00	204830.05
121 ENVIRONMENTAL	11083.19	0.00	11083.19
122 NAVAL SUPPORT ACTIVITY	298609.89	0.00	298609.89
123 COMPTROLLER	51177.47	0.00	51177.47
124 TIMEKEEPING	10098.69	0.00	10098.69
125 HRSC	36083.78	0.00	36083.78
126 MWR	63394.36	0.00	63394.36
127 POLICE DEPT	57613.47	0.00	57613.47
128 FIRE DEPT	23016.69	0.00	23016.69
129 COMPUTER INFO SVCS	349305.98	0.00	349305.98
130 SUPPLY DEPT	115837.11	0.00	115837.11
131 LIBRARY	247169.87	0.00	247169.87
132 SUPERINTENDENT	71968.57	0.00	71968.57
133 PROVOST	143924.33	0.00	143924.33
134 DEAN OF STUDENTS	177750.33	0.00	177750.33
146 CODE 06 COSTS	557522.00	0.00	557522.00
Total Cost	2419385.79	164186.81	2583572.60
Unit	2419385.78	164186.811	2583572.59

+--- Box Summary ---+			
	Fixed	Variable	Total
Cost	2419385.79	164186.81	2583572.60
Unit			2583572.5967

Financial Results [\$]  
 Box MSSC CODE 06 COSTS, Volume : 1 ACTIVITY

Category	Fixed	Variable	Total
101 ELECTRICITY	0.00	41776.96	41776.96
102 NATURAL GAS	0.00	6900.21	6900.21
103 MAIN GAS	0.00	3384.78	3384.78
104 CUSTODIAL NPS	0.00	38496.71	38496.71
105 GROUNDS MAINT NPS	0.00	6298.50	6298.50
106 CUSTODIAL LA MESA	0.00	292.99	292.99
107 GROUNDS MAINT LA MESA	0.00	15073.30	15073.30
108 WATER	0.00	8190.69	8190.69
109 SEWAGE	0.00	6323.91	6323.91
110 REFUSE	0.00	12988.17	12988.17
111 PHONES	0.00	22392.81	22392.81
120 PUBLIC WORKS	199338.90	0.00	199338.90
121 ENVIRONMENTAL	10990.02	0.00	10990.02
122 NAVAL SUPPORT ACTIVITY	300661.71	0.00	300661.71
123 COMPTROLLER	51931.37	0.00	51931.37
124 TIMEKEEPING	10209.46	0.00	10209.46
125 HRSC	36503.29	0.00	36503.29
126 MWR	64005.11	0.00	64005.11
127 POLICE DEPT	59024.28	0.00	59024.28
128 FIRE DEPT	23005.97	0.00	23005.97
129 COMPUTER INFO SVCS	311730.10	0.00	311730.10
130 SUPPLY DEPT	116878.43	0.00	116878.43
131 LIBRARY	213859.62	0.00	213859.62
132 SUPERINTENDENT	71594.32	0.00	71594.32
133 PROVOST	147848.29	0.00	147848.29
134 DEAN OF STUDENTS	172989.00	0.00	172989.00
146 CODE 06 COSTS	557082.00	0.00	557082.00
Total Cost	2347651.88	162119.02	2509770.90
Unit	2347651.87	162119.023	2509770.907

+--- Box Summary ---+			
	Fixed	Variable	Total
Cost	2347651.88	162119.02	2509770.90
Unit			2509770.9007

Financial Results [\$]  
 Box MSSC CODE 06 COSTS, Volume : 1 ACTIVITY

Category	Fixed	Variable	Total
101 ELECTRICITY	0.00	33444.04	33444.04
102 NATURAL GAS	0.00	210.95	210.95
103 MAIN GAS	0.00	3363.46	3363.46
104 CUSTODIAL NPS	0.00	38254.32	38254.32
105 GROUNDS MAINT NPS	0.00	6258.84	6258.84
106 CUSTODIAL LA MESA	0.00	292.99	292.99
107 GROUNDS MAINT LA MESA	0.00	15073.30	15073.30
108 WATER	0.00	14045.98	14045.98
109 SEWAGE	0.00	5416.05	5416.05
110 REFUSE	0.00	6651.37	6651.37
111 PHONES	0.00	89478.90	89478.90
120 PUBLIC WORKS	200966.90	0.00	200966.90
121 ENVIRONMENTAL	2592.31	0.00	2592.31
122 NAVAL SUPPORT ACTIVITY	261669.49	0.00	261669.49
123 COMPTROLLER	50594.87	0.00	50594.87
124 TIMEKEEPING	9936.33	0.00	9936.33
125 HRSC	33603.01	0.00	33603.01
126 MWR	66621.77	0.00	66621.77
127 POLICE DEPT	58113.88	0.00	58113.88
128 FIRE DEPT	22764.68	0.00	22764.68
129 COMPUTER INFO SVCS	219292.19	0.00	219292.19
130 SUPPLY DEPT	115717.34	0.00	115717.34
131 LIBRARY	107593.20	0.00	107593.20
132 SUPERINTENDENT	79504.75	0.00	79504.75
133 PROVOST	141130.83	0.00	141130.83
134 DEAN OF STUDENTS	182255.96	0.00	182255.96
146 CODE 06 COSTS	562172.00	0.00	562172.00
=====			=====
Total Cost	2114529.51	212490.20	2327019.72
Unit	2114529.51	212490.204	2327019.71
=====			=====

```

+--- Box Summary ---+
|           Fixed      Variable      Total      |
| Cost           2114529.51    212490.20    2327019.72 |
| Unit                                     2327019.7181 |
+-----+
  
```

Financial Results [\$]

Box MSSC CODE 06 COSTS, Volume : 1 ACTIVITY

Category	Fixed	Variable	Total
101 ELECTRICITY	0.00	36069.76	36069.76
102 NATURAL GAS	0.00	217.44	217.44
103 MAIN GAS	0.00	3466.98	3466.98
104 CUSTODIAL NPS	0.00	39431.60	39431.60
105 GROUNDS MAINT NPS	0.00	6451.46	6451.46
106 CUSTODIAL LA MESA	0.00	292.99	292.99
107 GROUNDS MAINT LA MESA	0.00	15073.30	15073.30
108 WATER	0.00	1887.73	1887.73
109 SEWAGE	0.00	3624.66	3624.66
110 REFUSE	0.00	9365.90	9365.90
111 PHONES	0.00	45035.04	45035.04
120 PUBLIC WORKS	365704.97	0.00	365704.97
121 ENVIRONMENTAL	8003.24	0.00	8003.24
122 NAVAL SUPPORT ACTIVITY	266470.69	0.00	266470.69
123 COMPTROLLER	51321.12	0.00	51321.12
124 TIMEKEEPING	10139.35	0.00	10139.35
125 HRSC	36827.18	0.00	36827.18
126 MWR	77954.75	0.00	77954.75
127 POLICE DEPT	59447.24	0.00	59447.24
128 FIRE DEPT	23847.39	0.00	23847.39
129 COMPUTER INFO SVCS	343968.57	0.00	343968.57
130 SUPPLY DEPT	131406.38	0.00	131406.38
131 LIBRARY	122617.09	0.00	122617.09
132 SUPERINTENDENT	78932.06	0.00	78932.06
133 PROVOST	133494.09	0.00	133494.09
134 DEAN OF STUDENTS	267075.94	0.00	267075.94
146 CODE 06 COSTS	627489.00	0.00	627489.00
=====			=====
Total Cost	2604699.07	160916.86	2765615.93
Unit	2604699.06	160916.861	2765615.93
=====			=====

```

+--- Box Summary ---+
|           Fixed    Variable    Total           |
| Cost       2604699.07  160916.86  2765615.93 |
| Unit                                 2765615.9310 |
+-----+
  
```



**APPENDIX Q. ENGINEERING AND COMPUTATIONAL SCIENCES FY 96  
QUARTERLY FINANCIAL RESULTS**

Financial Results [\\$]			
Box ECSC CODE 07 COSTS, Volume : 1 ACTIVITY			
Category	Fixed	Variable	Total
101 ELECTRICITY	0.00	124057.08	124057.08
102 NATURAL GAS	0.00	20490.25	20490.25
103 MAIN GAS	0.00	10051.13	10051.13
104 CUSTODIAL NPS	0.00	114316.35	114316.35
105 GROUNDS MAINT NPS	0.00	18703.46	18703.46
106 CUSTODIAL LA MESA	0.00	181.55	181.55
107 GROUNDS MAINT LA MESA	0.00	9340.13	9340.13
108 WATER	0.00	6988.62	6988.62
109 SEWAGE	0.00	5395.81	5395.81
110 REFUSE	0.00	11082.02	11082.02
111 PHONES	0.00	43762.80	43762.80
120 PUBLIC WORKS	601270.72	0.00	601270.72
121 ENVIRONMENTAL	32315.76	0.00	32315.76
122 NAVAL SUPPORT ACTIVITY	245052.73	0.00	245052.73
123 COMPTROLLER	65834.54	0.00	65834.54
124 TIMEKEEPING	14955.94	0.00	14955.94
125 HRSC	53255.36	0.00	53255.36
126 MWR	51297.77	0.00	51297.77
127 POLICE DEPT	41692.36	0.00	41692.36
128 FIRE DEPT	89790.08	0.00	89790.08
129 COMPUTER INFO SVCS	282211.46	0.00	282211.46
130 SUPPLY DEPT	180849.98	0.00	180849.98
131 LIBRARY	152353.88	0.00	152353.88
132 SUPERINTENDENT	65144.50	0.00	65144.50
133 PROVOST	141083.54	0.00	141083.54
134 DEAN OF STUDENTS	109183.25	0.00	109183.25
147 CODE 07 COSTS	1580731.00	0.00	1580731.00
=====			
Total Cost	3707022.86	364369.18	4071392.04
Unit	3707022.85	364369.184	4071392.04
=====			

+--- Box Summary ---+			
	Fixed	Variable	Total
Cost	3707022.86	364369.18	4071392.04
Unit			4071392.0426



Financial Results [\\$]

Box ECSC CODE 07 COSTS, Volume : 1 ACTIVITY

Category	Fixed	Variable	Total
101 ELECTRICITY	0.00	124057.08	124057.08
102 NATURAL GAS	0.00	20490.25	20490.25
103 MAIN GAS	0.00	10051.13	10051.13
104 CUSTODIAL NPS	0.00	114316.35	114316.35
105 GROUNDS MAINT NPS	0.00	18703.46	18703.46
106 CUSTODIAL LA MESA	0.00	181.55	181.55
107 GROUNDS MAINT LA MESA	0.00	9340.13	9340.13
108 WATER	0.00	6988.62	6988.62
109 SEWAGE	0.00	5395.81	5395.81
110 REFUSE	0.00	11082.02	11082.02
111 PHONES	0.00	43762.80	43762.80
120 PUBLIC WORKS	595954.45	0.00	595954.45
121 ENVIRONMENTAL	32634.96	0.00	32634.96
122 NAVAL SUPPORT ACTIVITY	247244.74	0.00	247244.74
123 COMPROLLER	67159.85	0.00	67159.85
124 TIMEKEEPING	15256.93	0.00	15256.93
125 HRSC	54354.04	0.00	54354.04
126 MWR	51891.87	0.00	51891.87
127 POLICE DEPT	42736.90	0.00	42736.90
128 FIRE DEPT	92095.23	0.00	92095.23
129 COMPUTER INFO SVCS	252342.14	0.00	252342.14
130 SUPPLY DEPT	184307.67	0.00	184307.67
131 LIBRARY	138640.03	0.00	138640.03
132 SUPERINTENDENT	65598.29	0.00	65598.29
133 PROVOST	145297.72	0.00	145297.72
134 DEAN OF STUDENTS	111750.00	0.00	111750.00
147 CODE 07 COSTS	1583081.00	0.00	1583081.00
=====			
Total Cost	3680345.82	364369.18	4044715.00
Unit	3680345.81	364369.184	4044715.00
=====			

+--- Box Summary ---+			
	Fixed	Variable	Total
Cost	3680345.82	364369.18	4044715.00
Unit			4044715.0016

Financial Results [\$]  
 Box ECSC CODE 07 COSTS, Volume : 1 ACTIVITY

Category	Fixed	Variable	Total
101 ELECTRICITY	0.00	99832.69	99832.69
102 NATURAL GAS	0.00	629.71	629.71
103 MAIN GAS	0.00	10040.17	10040.17
104 CUSTODIAL NPS	0.00	114191.72	114191.72
105 GROUNDS MAINT NPS	0.00	18683.07	18683.07
106 CUSTODIAL LA MESA	0.00	181.55	181.55
107 GROUNDS MAINT LA MESA	0.00	9340.13	9340.13
108 WATER	0.00	11988.57	11988.57
109 SEWAGE	0.00	4622.72	4622.72
110 REFUSE	0.00	5677.10	5677.10
111 PHONES	0.00	175325.44	175325.44
120 PUBLIC WORKS	603977.89	0.00	603977.89
121 ENVIRONMENTAL	7738.21	0.00	7738.21
122 NAVAL SUPPORT ACTIVITY	215241.28	0.00	215241.28
123 COMPTROLLER	65510.21	0.00	65510.21
124 TIMEKEEPING	14879.45	0.00	14879.45
125 HRSC	50136.99	0.00	50136.99
126 MWR	54027.38	0.00	54027.38
127 POLICE DEPT	42080.28	0.00	42080.28
128 FIRE DEPT	91844.63	0.00	91844.63
129 COMPUTER INFO SVCS	177561.08	0.00	177561.08
130 SUPPLY DEPT	182906.33	0.00	182906.33
131 LIBRARY	69841.20	0.00	69841.20
132 SUPERINTENDENT	73010.46	0.00	73010.46
133 PROVOST	138741.87	0.00	138741.87
134 DEAN OF STUDENTS	118466.37	0.00	118466.37
147 CODE 07 COSTS	1481623.00	0.00	1481623.00
=====			
Total Cost	3387586.64	450512.86	3838099.50
Unit	3387586.64	450512.855	3838099.49
=====			

+--- Box Summary ---+			
	Fixed	Variable	Total
Cost	3387586.64	450512.86	3838099.50
Unit			3838099.4966





**APPENDIX R. OPERATIONAL AND APPLIED SCIENCE FY 96 QUARTERLY  
FINANCIAL RESULTS**

Financial Results [\$]

Box OASC CODE 08 COSTS, Volume : 1 ACTIVITY

Category	Fixed	Variable	Total
101 ELECTRICITY	0.00	80510.14	80510.14
102 NATURAL GAS	0.00	13297.69	13297.69
103 MAIN GAS	0.00	6522.95	6522.95
104 CUSTODIAL NPS	0.00	74188.64	74188.64
105 GROUNDS MAINT NPS	0.00	12138.11	12138.11
106 CUSTODIAL LA MESA	0.00	263.47	263.47
107 GROUNDS MAINT LA MESA	0.00	13554.58	13554.58
108 WATER	0.00	8315.12	8315.12
109 SEWAGE	0.00	6419.98	6419.98
110 REFUSE	0.00	13185.48	13185.48
111 PHONES	0.00	31255.11	31255.11
120 PUBLIC WORKS	388618.23	0.00	388618.23
121 ENVIRONMENTAL	20972.17	0.00	20972.17
122 NAVAL SUPPORT ACTIVITY	298239.22	0.00	298239.22
123 COMPTROLLER	84530.61	0.00	84530.61
124 TIMEKEEPING	13117.64	0.00	13117.64
125 HRSC	47430.85	0.00	47430.85
126 MWR	62976.78	0.00	62976.78
127 POLICE DEPT	54614.28	0.00	54614.28
128 FIRE DEPT	53154.29	0.00	53154.29
129 COMPUTER INFO SVCS	345832.48	0.00	345832.48
130 SUPPLY DEPT	155135.51	0.00	155135.51
131 LIBRARY	208271.00	0.00	208271.00
132 SUPERINTENDENT	69186.11	0.00	69186.11
133 PROVOST	142758.88	0.00	142758.88
134 DEAN OF STUDENTS	149799.42	0.00	149799.42
148 CODE 08 COSTS	1262346.00	0.00	1262346.00
=====			
Total Cost	3356983.47	259651.26	3616634.73
Unit	3356983.47	259651.261	3616634.733
=====			

```

+--- Box Summary -----+
|           Fixed      Variable      Total      |
| Cost           3356983.47    259651.26    3616634.73 |
| Unit                                     3616634.7332 |
+-----+
  
```

Financial Results [\$]

Box OASC CODE 08 COSTS, Volume : 1 ACTIVITY

Category	Fixed	Variable	Total
101 ELECTRICITY	0.00	81280.46	81280.46
102 NATURAL GAS	0.00	13424.92	13424.92
103 MAIN GAS	0.00	6585.36	6585.36
104 CUSTODIAL NPS	0.00	74898.47	74898.47
105 GROUNDS MAINT NPS	0.00	12254.25	12254.25
106 CUSTODIAL LA MESA	0.00	263.47	263.47
107 GROUNDS MAINT LA MESA	0.00	13554.58	13554.58
108 WATER	0.00	8333.95	8333.95
109 SEWAGE	0.00	6434.52	6434.52
110 REFUSE	0.00	13215.34	13215.34
111 PHONES	0.00	31473.72	31473.72
120 PUBLIC WORKS	388862.25	0.00	388862.25
121 ENVIRONMENTAL	21381.97	0.00	21381.97
122 NAVAL SUPPORT ACTIVITY	301526.16	0.00	301526.16
123 COMPTROLLER	86508.63	0.00	86508.63
124 TIMEKEEPING	13474.10	0.00	13474.10
125 HRSC	48734.28	0.00	48734.28
126 MWR	63829.58	0.00	63829.58
127 POLICE DEPT	56015.16	0.00	56015.16
128 FIRE DEPT	55120.52	0.00	55120.52
129 COMPUTER INFO SVCS	309834.65	0.00	309834.65
130 SUPPLY DEPT	159274.93	0.00	159274.93
131 LIBRARY	200585.59	0.00	200585.59
132 SUPERINTENDENT	70543.63	0.00	70543.63
133 PROVOST	147398.19	0.00	147398.19
134 DEAN OF STUDENTS	162261.00	0.00	162261.00
148 CODE 08 COSTS	1269514.00	0.00	1269514.00
=====			
Total Cost	3354864.67	261719.02	3616583.69
Unit	3354864.67	261719.017	3616583.68
=====			

+--- Box Summary ---+			
	Fixed	Variable	Total
Cost	3354864.67	261719.02	3616583.69
Unit			3616583.6876

Financial Results [\$]			
Box OASC CODE 08 COSTS, Volume : 1 ACTIVITY			
Category	Fixed	Variable	Total
101 ELECTRICITY	0.00	65558.85	65558.85
102 NATURAL GAS	0.00	413.52	413.52
103 MAIN GAS	0.00	6593.25	6593.25
104 CUSTODIAL NPS	0.00	74988.24	74988.24
105 GROUNDS MAINT NPS	0.00	12268.93	12268.93
106 CUSTODIAL LA MESA	0.00	263.47	263.47
107 GROUNDS MAINT LA MESA	0.00	13554.58	13554.58
108 WATER	0.00	14303.91	14303.91
109 SEWAGE	0.00	5515.50	5515.50
110 REFUSE	0.00	6773.51	6773.51
111 PHONES	0.00	126064.13	126064.13
120 PUBLIC WORKS	394995.49	0.00	394995.49
121 ENVIRONMENTAL	5081.58	0.00	5081.58
122 NAVAL SUPPORT ACTIVITY	262616.84	0.00	262616.84
123 COMPTROLLER	84390.77	0.00	84390.77
124 TIMEKEEPING	13160.58	0.00	13160.58
125 HRSC	45019.03	0.00	45019.03
126 MWR	66485.67	0.00	66485.67
127 POLICE DEPT	55162.24	0.00	55162.24
128 FIRE DEPT	55111.96	0.00	55111.96
129 COMPUTER INFO SVCS	218112.73	0.00	218112.73
130 SUPPLY DEPT	158312.43	0.00	158312.43
131 LIBRARY	105705.60	0.00	105705.60
132 SUPERINTENDENT	78412.26	0.00	78412.26
133 PROVOST	141011.39	0.00	141011.39
134 DEAN OF STUDENTS	171224.68	0.00	171224.68
=====			
Total Cost	1854803.25	326297.88	2181101.13
Unit	1854803.25	326297.882	2181101.13
=====			

+--- Box Summary ---+-----+-----+			
	Fixed	Variable	Total
Cost	1854803.25	326297.88	2181101.13
Unit			2181101.1336



Financial Results [\$]

Box OASC CODE 08 COSTS, Volume : 1 ACTIVITY

Category	Fixed	Variable	Total
101 ELECTRICITY	0.00	68123.23	68123.23
102 NATURAL GAS	0.00	410.68	410.68
103 MAIN GAS	0.00	6547.91	6547.91
104 CUSTODIAL NPS	0.00	74472.57	74472.57
105 GROUNDS MAINT NPS	0.00	12184.56	12184.56
106 CUSTODIAL LA MESA	0.00	263.47	263.47
107 GROUNDS MAINT LA MESA	0.00	13554.58	13554.58
108 WATER	0.00	1912.37	1912.37
109 SEWAGE	0.00	3671.97	3671.97
110 REFUSE	0.00	9488.16	9488.16
111 PHONES	0.00	62240.52	62240.52
120 PUBLIC WORKS	692513.51	0.00	692513.51
121 ENVIRONMENTAL	15115.33	0.00	15115.33
122 NAVAL SUPPORT ACTIVITY	266187.91	0.00	266187.91
123 COMPROLLER	84739.77	0.00	84739.77
124 TIMEKEEPING	13169.66	0.00	13169.66
125 HRSC	48403.65	0.00	48403.65
126 MWR	77454.64	0.00	77454.64
127 POLICE DEPT	56355.99	0.00	56355.99
128 FIRE DEPT	54872.20	0.00	54872.20
129 COMPUTER INFO SVCS	340608.30	0.00	340608.30
130 SUPPLY DEPT	175959.01	0.00	175959.01
131 LIBRARY	104026.76	0.00	104026.76
132 SUPERINTENDENT	75985.25	0.00	75985.25
133 PROVOST	132436.51	0.00	132436.51
134 DEAN OF STUDENTS	226982.23	0.00	226982.23
148 CODE 08 COSTS	1273830.00	0.00	1273830.00
=====			
Total Cost	3638640.73	252870.00	3891510.73
Unit	3638640.72	252870.001	3891510.72
=====			

```

+--- Box Summary -----+
|           Fixed      Variable      Total      |
| Cost           3638640.73    252870.00    3891510.73 |
| Unit                                     3891510.7265 |
+-----+
  
```



**APPENDIX S. RESEARCH DEPARTMENT FY 96 QUARTERLY FINANCIAL RESULTS**

		Financial Results [\$]		
Box RESC CODE 09 COSTS, Volume : 1		ACTIVITY		
Category		Fixed	Variable	Total
101	ELECTRICITY	0.00	4337.20	4337.20
102	NATURAL GAS	0.00	716.37	716.37
103	MAIN GAS	0.00	351.40	351.40
104	CUSTODIAL NPS	0.00	3996.65	3996.65
105	GROUNDS MAINT NPS	0.00	653.90	653.90
108	WATER	0.00	175.19	175.19
109	SEWAGE	0.00	135.26	135.26
110	REFUSE	0.00	277.80	277.80
111	PHONES	0.00	2454.57	2454.57
120	PUBLIC WORKS	21083.80	0.00	21083.80
121	ENVIRONMENTAL	1129.80	0.00	1129.80
122	NAVAL SUPPORT ACTIVITY	6874.24	0.00	6874.24
123	COMPROLLER	9198.32	0.00	9198.32
124	TIMEKEEPING	972.95	0.00	972.95
125	HRSC	3641.79	0.00	3641.79
126	MWR	1314.33	0.00	1314.33
127	POLICE DEPT	463.69	0.00	463.69
128	FIRE DEPT	3164.20	0.00	3164.20
129	COMPUTER INFO SVCS	7290.00	0.00	7290.00
130	SUPPLY DEPT	12952.62	0.00	12952.62
132	SUPERINTENDENT	44030.00	0.00	44030.00
133	PROVOST	24280.20	0.00	24280.20
149	CODE 09 COSTS	151073.00	0.00	151073.00
		=====	=====	=====
Total Cost		287468.95	13098.33	300567.28
Unit		287468.954	13098.3306	300567.285
		=====	=====	=====

+--- Box Summary ---+			
	Fixed	Variable	Total
Cost	287468.95	13098.33	300567.28
Unit			300567.2850

Financial Results [\\$]

Box RESC CODE 09 COSTS, Volume : 1 ACTIVITY

Category	Fixed	Variable	Total
101 ELECTRICITY	0.00	4337.20	4337.20
102 NATURAL GAS	0.00	716.37	716.37
103 MAIN GAS	0.00	351.40	351.40
104 CUSTODIAL NPS	0.00	3996.65	3996.65
105 GROUNDS MAINT NPS	0.00	653.90	653.90
108 WATER	0.00	175.19	175.19
109 SEWAGE	0.00	135.26	135.26
110 REFUSE	0.00	277.80	277.80
111 PHONES	0.00	2454.57	2454.57
120 PUBLIC WORKS	20897.39	0.00	20897.39
121 ENVIRONMENTAL	1140.96	0.00	1140.96
122 NAVAL SUPPORT ACTIVITY	6935.73	0.00	6935.73
123 COMPTROLLER	9383.49	0.00	9383.49
124 TIMEKEEPING	992.53	0.00	992.53
125 HRSC	3716.93	0.00	3716.93
126 MWR	1329.55	0.00	1329.55
127 POLICE DEPT	475.31	0.00	475.31
128 FIRE DEPT	3245.44	0.00	3245.44
129 COMPUTER INFO SVCS	6518.42	0.00	6518.42
130 SUPPLY DEPT	13200.27	0.00	13200.27
132 SUPERINTENDENT	44336.71	0.00	44336.71
133 PROVOST	25005.45	0.00	25005.45
149 CODE 09 COSTS	131495.00	0.00	131495.00
=====			
Total Cost	268673.17	13098.33	281771.50
Unit	268673.169	13098.3306	281771.500
=====			

```

+---. Box Summary -----+
|                               Fixed   Variable   Total       |
|                               |         |         |         |
| Cost           268673.17    13098.33    281771.50 |
| Unit                               281771.5004 |
+-----+
  
```

Financial Results [\$]

Category	Box RESC CODE 09 COSTS, Volume : 1	Fixed	Variable	ACTIVITY	Total
101 ELECTRICITY		0.00	3494.09		3494.09
102 NATURAL GAS		0.00	22.04		22.04
103 MAIN GAS		0.00	351.40		351.40
104 CUSTODIAL NPS		0.00	3996.65		3996.65
105 GROUNDS MAINT NPS		0.00	653.90		653.90
108 WATER		0.00	300.66		300.66
109 SEWAGE		0.00	115.93		115.93
110 REFUSE		0.00	142.38		142.38
111 PHONES		0.00	9841.49		9841.49
120 PUBLIC WORKS		21201.72	0.00		21201.72
121 ENVIRONMENTAL		270.83	0.00		270.83
122 NAVAL SUPPORT ACTIVITY		6040.53	0.00		6040.53
123 COMPTROLLER		9158.93	0.00		9158.93
124 TIMEKEEPING		968.98	0.00		968.98
125 HRSC		3432.08	0.00		3432.08
126 MWR		1384.82	0.00		1384.82
127 POLICE DEPT		468.07	0.00		468.07
128 FIRE DEPT		3240.33	0.00		3240.33
129 COMPUTER INFO SVCS		4588.56	0.00		4588.56
130 SUPPLY DEPT		13114.25	0.00		13114.25
132 SUPERINTENDENT		49446.72	0.00		49446.72
133 PROVOST		23889.54	0.00		23889.54
149 CODE 09 COSTS		106983.00	0.00		106983.00
=====					
Total Cost		244188.36	18918.54		263106.90
Unit		244188.358	18918.5390		263106.897
=====					

+--- Box Summary ---+			
	Fixed	Variable	Total
Cost	244188.36	18918.54	263106.90
Unit			263106.8978

Financial Results [\$]

Box RESC CODE 09 COSTS, Volume : 1 ACTIVITY

Category	Fixed	Variable	Total
101 ELECTRICITY	0.00	3655.91	3655.91
102 NATURAL GAS	0.00	22.04	22.04
103 MAIN GAS	0.00	351.40	351.40
104 CUSTODIAL NPS	0.00	3996.65	3996.65
105 GROUNDS MAINT NPS	0.00	653.90	653.90
108 WATER	0.00	40.25	40.25
109 SEWAGE	0.00	77.29	77.29
110 REFUSE	0.00	199.72	199.72
111 PHONES	0.00	4874.32	4874.32
120 PUBLIC WORKS	37428.07	0.00	37428.07
121 ENVIRONMENTAL	811.18	0.00	811.18
122 NAVAL SUPPORT ACTIVITY	6130.43	0.00	6130.43
123 COMPTROLLER	9209.27	0.00	9209.27
124 TIMEKEEPING	974.11	0.00	974.11
125 HRSC	3706.54	0.00	3706.54
126 MWR	1615.23	0.00	1615.23
127 POLICE DEPT	478.37	0.00	478.37
128 FIRE DEPT	3252.11	0.00	3252.11
129 COMPUTER INFO SVCS	7174.26	0.00	7174.26
130 SUPPLY DEPT	14647.74	0.00	14647.74
132 SUPERINTENDENT	48115.09	0.00	48115.09
133 PROVOST	22501.63	0.00	22501.63
149 CODE 09 COSTS	175835.00	0.00	175835.00
=====			
Total Cost	331879.04	13871.49	345750.53
Unit	331879.038	13871.4868	345750.525
=====			

```

+--- Box Summary -----+
|                               Fixed   Variable   Total     |
|                               |         |         |         |
| Cost                          331879.04   13871.49   345750.53 |
| Unit                               345750.5254 |
+-----+
  
```





**APPENDIX T. SCHOOL OF AVIATION SAFETY FY 96 QUARTERLY  
FINANCIAL RESULTS**

		Financial Results [\$]		
Box SASC CODE 10 COSTS, Volume : 1		ACTIVITY		
Category		Fixed	Variable	Total
101	ELECTRICITY	0.00	5618.78	5618.78
102	NATURAL GAS	0.00	928.04	928.04
103	MAIN GAS	0.00	455.23	455.23
104	CUSTODIAL NPS	0.00	5177.60	5177.60
105	GROUNDS MAINT NPS	0.00	847.11	847.11
108	WATER	0.00	1914.53	1914.53
109	SEWAGE	0.00	1478.18	1478.18
110	REFUSE	0.00	3035.91	3035.91
111	PHONES	0.00	1835.97	1835.97
120	PUBLIC WORKS	27598.41	0.00	27598.41
121	ENVIRONMENTAL	1463.64	0.00	1463.64
122	NAVAL SUPPORT ACTIVITY	70062.17	0.00	70062.17
123	COMPROLLER	5914.20	0.00	5914.20
124	TIMEKEEPING	543.83	0.00	543.83
125	HRSC	2035.43	0.00	2035.43
126	MWR	15006.27	0.00	15006.27
127	POLICE DEPT	3474.98	0.00	3474.98
128	FIRE-DEPT	2263.89	0.00	2263.89
129	COMPUTER INFO SVCS	82075.84	0.00	82075.84
130	SUPPLY DEPT	3721.83	0.00	3721.83
132	SUPERINTENDENT	41813.87	0.00	41813.87
150	CODE 10 COSTS	56338.00	0.00	56338.00
		=====	=====	=====
Total Cost		312312.36	21291.36	333603.71
Unit		312312.356	21291.3563	333603.713
		=====	=====	=====

+--- Box Summary -----+			
	Fixed	Variable	Total
Cost	312312.36	21291.36	333603.71
Unit			333603.7130

Financial Results [\$]

Box SASC CODE 10 COSTS, Volume : 1 ACTIVITY

Category	Fixed	Variable	Total
101 ELECTRICITY	0.00	5618.78	5618.78
102 NATURAL GAS	0.00	928.04	928.04
103 MAIN GAS	0.00	455.23	455.23
104 CUSTODIAL NPS	0.00	5177.60	5177.60
105 GROUNDS MAINT NPS	0.00	847.11	847.11
108 WATER	0.00	1914.53	1914.53
109 SEWAGE	0.00	1478.18	1478.18
110 REFUSE	0.00	3035.91	3035.91
111 PHONES	0.00	1835.97	1835.97
120 PUBLIC WORKS	27354.39	0.00	27354.39
121 ENVIRONMENTAL	1478.10	0.00	1478.10
122 NAVAL SUPPORT ACTIVITY	70688.88	0.00	70688.88
123 COMPTROLLER	6033.26	0.00	6033.26
124 TIMEKEEPING	554.77	0.00	554.77
125 HRSC	2077.42	0.00	2077.42
126 MWR	15180.07	0.00	15180.07
127 POLICE DEPT	3562.04	0.00	3562.04
128 FIRE DEPT	2322.01	0.00	2322.01
129 COMPUTER INFO SVCS	73388.91	0.00	73388.91
130 SUPPLY DEPT	3792.99	0.00	3792.99
132 SUPERINTENDENT	42105.14	0.00	42105.14
150 CODE 10 COSTS	57355.00	0.00	57355.00
=====			
Total Cost	305892.98	21291.36	327184.34
Unit	305892.984	21291.3563	327184.340
=====			

+--- Box Summary ---+			
	Fixed	Variable	Total
Cost	305892.98	21291.36	327184.34
Unit			327184.3403

Financial Results [\$]				
Category	Box SASC CODE 10 COSTS, Volume : 1	ACTIVITY		
		Fixed	Variable	
			Total	
101 ELECTRICITY		0.00	4526.54	4526.54
102 NATURAL GAS		0.00	28.55	28.55
103 MAIN GAS		0.00	455.23	455.23
104 CUSTODIAL NPS		0.00	5177.60	5177.60
105 GROUNDS MAINT NPS		0.00	847.11	847.11
108 WATER		0.00	3285.76	3285.76
109 SEWAGE		0.00	1266.97	1266.97
110 REFUSE		0.00	1555.95	1555.95
111 PHONES		0.00	7361.25	7361.25
120 PUBLIC WORKS		27752.76	0.00	27752.76
121 ENVIRONMENTAL		350.86	0.00	350.86
122 NAVAL SUPPORT ACTIVITY		61564.95	0.00	61564.95
123 COMPTROLLER		5888.88	0.00	5888.88
124 TIMEKEEPING		541.61	0.00	541.61
125 HRSC		1918.22	0.00	1918.22
126 MWR		15811.14	0.00	15811.14
127 POLICE DEPT		3507.76	0.00	3507.76
128 FIRE DEPT		2318.35	0.00	2318.35
129 COMPUTER INFO SVCS		51661.22	0.00	51661.22
130 SUPPLY DEPT		3768.27	0.00	3768.27
132 SUPERINTENDENT		46957.95	0.00	46957.95
150 CODE 10 COSTS		55725.00	0.00	55725.00
=====				
Total Cost		277766.97	24504.98	302271.94
Unit		277766.969	24504.9756	302271.944
=====				

+--- Box Summary ---+			
	Fixed	Variable	Total
Cost	277766.97	24504.98	302271.94
Unit			302271.9446

Financial Results [\$]  
 Box SASC CODE 10 COSTS, Volume : 1 ACTIVITY

Category	Fixed	Variable	Total
101 ELECTRICITY	0.00	4736.17	4736.17
102 NATURAL GAS	0.00	28.55	28.55
103 MAIN GAS	0.00	455.23	455.23
104 CUSTODIAL NPS	0.00	5177.60	5177.60
105 GROUNDS MAINT NPS	0.00	847.11	847.11
108 WATER	0.00	439.92	439.92
109 SEWAGE	0.00	844.69	844.69
110 REFUSE	0.00	2182.64	2182.64
111 PHONES	0.00	3645.90	3645.90
120 PUBLIC WORKS	48992.84	0.00	48992.84
121 ENVIRONMENTAL	1050.87	0.00	1050.87
122 NAVAL SUPPORT ACTIVITY	62481.28	0.00	62481.28
123 COMPTROLLER	5921.24	0.00	5921.24
124 TIMEKEEPING	544.48	0.00	544.48
125 HRSC	2071.62	0.00	2071.62
126 MWR	18441.80	0.00	18441.80
127 POLICE DEPT	3584.96	0.00	3584.96
128 FIRE DEPT	2326.79	0.00	2326.79
129 COMPUTER INFO SVCS	80772.77	0.00	80772.77
130 SUPPLY DEPT	4208.91	0.00	4208.91
132 SUPERINTENDENT	45693.35	0.00	45693.35
150 CODE 10 COSTS	61770.00	0.00	61770.00
=====			
Total Cost	337860.90	18357.82	356218.72
Unit	337860.897	18357.8231	356218.720
=====			

+--- Box Summary ---+			
	Fixed	Variable	Total
Cost	337860.90	18357.82	356218.72
Unit			356218.7206



**APPENDIX U. RESIDUAL FY 96 QUARTERLY FINANCIAL RESULTS**

Financial Results [\$]

Category	Box NMC	RESIDUAL COSTS, Volume : 1	ACTIVITY	Total
		Fixed	Variable	
101 ELECTRICITY		0.00	53074.54	53074.54
102 NATURAL GAS		0.00	8766.21	8766.21
103 MAIN GAS		0.00	4300.11	4300.11
104 CUSTODIAL NPS		0.00	48907.22	48907.22
105 GROUNDS MAINT NPS		0.00	8001.78	8001.78
108 WATER		0.00	2289.03	2289.03
109 SEWAGE		0.00	1767.32	1767.32
110 REFUSE		0.00	3629.77	3629.77
111 PHONES		0.00	3830.13	3830.13
120 PUBLIC WORKS		256983.79	0.00	256983.79
121 ENVIRONMENTAL		13825.44	0.00	13825.44
122 NAVAL SUPPORT ACTIVITY		78246.71	0.00	78246.71
123 COMPTROLLER		15077.90	0.00	15077.90
124 TIMEKEEPING		1204.96	0.00	1204.96
125 HRSC		48919.78	0.00	48919.78
126 MWR		16345.49	0.00	16345.49
127 POLICE DEPT		3875.21	0.00	3875.21
128 FIRE DEPT		39496.86	0.00	39496.86
129 COMPUTER INFO SVCS		90661.27	0.00	90661.27
130 SUPPLY DEPT		9088.94	0.00	9088.94
131 LIBRARY		202598.25	0.00	202598.25
132 SUPERINTENDENT		22246.94	0.00	22246.94
133 PROVOST		6070.05	0.00	6070.05
=====				
Total Cost		804641.59	134566.11	939207.70
Unit		804641.591	134566.106	939207.698
=====				

+--- Box Summary ---+-----+-----+			
	Fixed	Variable	Total
Cost	804641.59	134566.11	939207.70
Unit			939207.6985



Financial Results [\$]

Category	Box NMC RESIDUAL COSTS, Volume : 1 ACTIVITY		Total
	Fixed	Variable	
101 ELECTRICITY	0.00	53074.54	53074.54
102 NATURAL GAS	0.00	8766.21	8766.21
103 MAIN GAS	0.00	4300.11	4300.11
104 CUSTODIAL NPS	0.00	48907.22	48907.22
105 GROUNDS MAINT NPS	0.00	8001.78	8001.78
108 WATER	0.00	2289.03	2289.03
109 SEWAGE	0.00	1767.32	1767.32
110 REFUSE	0.00	3629.77	3629.77
111 PHONES	0.00	3830.13	3830.13
120 PUBLIC WORKS	254711.61	0.00	254711.61
121 ENVIRONMENTAL	13962.00	0.00	13962.00
122 NAVAL SUPPORT ACTIVITY	78946.63	0.00	78946.63
123 COMPTROLLER	15381.43	0.00	15381.43
124 TIMEKEEPING	1229.21	0.00	1229.21
125 HRSC	49929.02	0.00	49929.02
126 MWR	16534.80	0.00	16534.80
127 POLICE DEPT	3972.29	0.00	3972.29
128 FIRE DEPT	40510.85	0.00	40510.85
129 COMPUTER INFO SVCS	81065.66	0.00	81065.66
130 SUPPLY DEPT	9262.71	0.00	9262.71
131 LIBRARY	184361.75	0.00	184361.75
132 SUPERINTENDENT	22401.91	0.00	22401.91
133 PROVOST	6251.36	0.00	6251.36
Total Cost	778521.25	134566.11	913087.35
Unit	778521.246	134566.106	913087.352

+--- Box Summary ---+			
	Fixed	Variable	Total
Cost	778521.25	134566.11	913087.35
Unit			913087.3529

Financial Results [\$]			
Box NMC RESIDUAL COSTS, Volume : 1 ACTIVITY			
Category	Fixed	Variable	Total
101 ELECTRICITY	0.00	42757.40	42757.40
102 NATURAL GAS	0.00	269.70	269.70
103 MAIN GAS	0.00	4300.11	4300.11
104 CUSTODIAL NPS	0.00	48907.23	48907.23
105 GROUNDS MAINT NPS	0.00	8001.78	8001.78
108 WATER	0.00	3928.49	3928.49
109 SEWAGE	0.00	1514.80	1514.80
110 REFUSE	0.00	1860.31	1860.31
111 PHONES	0.00	15356.73	15356.73
120 PUBLIC WORKS	258421.05	0.00	258421.05
121 ENVIRONMENTAL	3314.20	0.00	3314.20
122 NAVAL SUPPORT ACTIVITY	68756.85	0.00	68756.85
123 COMPROLLER	15013.34	0.00	15013.34
124 TIMEKEEPING	1200.05	0.00	1200.05
125 HRSC	46102.66	0.00	46102.66
126 MWR	17222.19	0.00	17222.19
127 POLICE DEPT	3911.77	0.00	3911.77
128 FIRE DEPT	40447.07	0.00	40447.07
129 COMPUTER INFO SVCS	57065.17	0.00	57065.17
130 SUPPLY DEPT	9202.36	0.00	9202.36
131 LIBRARY	94380.00	0.00	94380.00
132 SUPERINTENDENT	24983.84	0.00	24983.84
133 PROVOST	5972.38	0.00	5972.38
=====			
Total Cost	645992.93	126896.55	772889.48
Unit	645992.930	126896.546	772889.477
=====			

+--- Box Summary ---+			
	Fixed	Variable	Total
Cost	645992.93	126896.55	772889.48
Unit			772889.4777

Financial Results [\$]

Category	RESIDUAL COSTS, Volume : 1		Total
	Fixed	Variable	
101 ELECTRICITY	0.00	44737.52	44737.52
102 NATURAL GAS	0.00	269.70	269.70
103 MAIN GAS	0.00	4300.11	4300.11
104 CUSTODIAL NPS	0.00	48907.22	48907.22
105 GROUNDS MAINT NPS	0.00	8001.78	8001.78
108 WATER	0.00	525.97	525.97
109 SEWAGE	0.00	1009.92	1009.92
110 REFUSE	0.00	2609.58	2609.58
111 PHONES	0.00	7605.93	7605.93
120 PUBLIC WORKS	456198.92	0.00	456198.92
121 ENVIRONMENTAL	9926.46	0.00	9926.46
122 NAVAL SUPPORT ACTIVITY	69780.23	0.00	69780.23
123 COMPTROLLER	15095.85	0.00	15095.85
124 TIMEKEEPING	1206.41	0.00	1206.41
125 HRSC	49789.44	0.00	49789.44
126 MWR	20087.62	0.00	20087.62
127 POLICE DEPT	3997.86	0.00	3997.86
128 FIRE DEPT	40594.19	0.00	40594.19
129 COMPUTER INFO SVCS	89221.89	0.00	89221.89
130 SUPPLY DEPT	10278.42	0.00	10278.42
131 LIBRARY	98884.75	0.00	98884.75
132 SUPERINTENDENT	24311.01	0.00	24311.01
133 PROVOST	5625.41	0.00	5625.41
=====			
Total Cost	894998.46	117967.73	1012966.19
Unit	894998.455	117967.733	1012966.18
=====			

+--- Box Summary ---+			
	Fixed	Variable	Total
Cost	894998.46	117967.73	1012966.19
Unit			1012966.1887



## INITIAL DISTRIBUTION LIST

	No. Copies
1. Defense Technical Information Center..... 8725 John J. Kingman Rd., STE 0944 Ft. Belvoir, VA 22060-6218	2
2. Dudley Knox Library..... Naval Postgraduate School 411 Dyer Rd. Monterey, CA 93943-5101	2
3. Dr. Richard Elster..... Code 01 Naval Postgraduate School Monterey, CA 93943-5101	1
4. CAPT Mary J. Meyer, USN..... Commander Naval Support Activity, Monterey Bay Monterey, CA 93943-5101	1
5. Professor Kenneth Euske..... Code SM/EE Naval Postgraduate School Monterey, CA 93943-5101	2
6. CDR James Kerber, SC, USN..... Code SM/KE Naval Postgraduate School Monterey, CA 93943-5101	1
7. Professor Gil Howard..... Code 01 Naval Postgraduate School Monterey, CA 93943-5101	1
8. Dean James Blandin..... Code 06 Naval Postgraduate School Monterey, CA 93943-5101	1

- 9. Dean Rudy Panholzer.....1  
Code 07  
Naval Postgraduate School  
Monterey, CA 93943-5101
  
- 10. Dean Peter Purdue.....1  
Code 08  
Naval Postgraduate School  
Monterey, CA 93943-5101
  
- 11. LT Brian Theodore Drapp, SC, USN.....1  
2704 Viola Lane  
Valrico, FL 33594