

JPRS-UAC-93-003  
26 April 1993

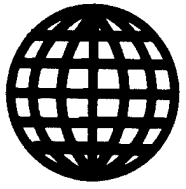

**FOREIGN  
BROADCAST  
INFORMATION  
SERVICE**

# ***JPRS Report***

# **Central Eurasia**

***AVIATION & COSMONAUTICS***

***No 9, September 1992***

19971229 183

**DTIC QUALITY INSPECTED 2**

**DISTRIBUTION STATEMENT A**

**Approved for public release;  
Distribution Unlimited**

REPRODUCED BY  
U.S. DEPARTMENT OF COMMERCE  
NATIONAL TECHNICAL INFORMATION SERVICE  
SPRINGFIELD, VA 22161

**Central Eurasia**  
**AVIATION AND COSMONAUTICS**  
 No 9, September 1992

JPRS-UAC-93-003

CONTENTS

26 April 1993

[The following are translations of selected articles in the Russian-language monthly journal AVIATSIYA I KOSMONAVTIKA published in Moscow. Refer to the table of contents for a listing of any articles not translated.]

Independent Body to Protect Professional Interests of Pilots Sought [Colonel N. Litvinchuk; pp 2-3] .....	1
Future Use of Artificial Intelligence on Fighters Considered [Lieutenant-Colonel V. Simochenko; pp 4-5] .....	4
Theoretical Refinement to Zhukovskiy Aerodynamic Theorem Proposed [Colonel G. Karachevskiy; pp 6-7] .....	6
Comprehensive Approach to Seeking Causes of Air Accidents Urged [Colonel (Reserve) V. Dudin; pp 10-11] .....	9
Consideration of Psychological Factors in Training and Performance [Lieutenant-Colonel of the Medical Service V. Kozlov; pp 12-13] .....	11
New Edition of Aviation Engineering Support Manual [Colonel (Reserve) A. Poluektov; pp 22-23] .....	13
Plight of CIS Strategic Fliers Outside Russia Described [Lieutenant-Colonel M. Syrtlanov; p 33] .....	15
More History of Failed N1-L3 Lunar Launch-Vehicle Project [R. Dolgopyatov et al.; pp 34-37] .....	17
Plan to Counter Ozone-Layer Destruction With Space-Based Mirrors [Lieutenant-Colonel V. Maksimovskiy; pp 38-39] .....	23
Soviet Air Advisor Recalls Vietnam Tactics Against B-52 Bombers [Major-General of Aviation (Retired) M. Fesenko; pp 42-43] .....	26
Comparison of ZMS2 and KC-135A Tanker Aircraft Data [V. Ilin; pp 46-47] .....	28
Articles Not Translated .....	29
Publication Data .....	30

### Independent Body to Protect Professional Interests of Pilots Sought

93UM0241A Moscow AVIATSIYA I KOSMONAVTIKA in Russian No 9, Sep 92 (signed to press 29 Jul 92)  
pp 2-3

[Article by Colonel N. Litvinchuk under the rubric "Military Reform: The Human Factor": "Who Will Protect?"]

[Text] The problem of professional protections could scarcely be formulated under the conditions of the administrative-command system, which declared the freedom of the individual but in practice toyed with the fates of people. We do not find a definition of this concept in dictionaries and encyclopedias, which in no way testifies to the absence of a problem, but rather indicates the attitude of the official political and authority structures toward it. Therefore, while making no claim to an exhaustive definition, I will take it upon myself to be so bold as to formulate the basic provisions of it.

Professional protections, in my opinion, are understood to be the assurance of the rights of a person in a certain profession to carry out unimpeded activity that corresponds to the nature and level of his training; the creation of the optimal conditions facilitating the improvement of professional proficiency and the practical realization of acquired knowledge and skills; material compensation, social and domestic support and social guarantees in the event of the forced curtailment of professional activity, regardless of the reasons, as well as in the event of age-related retirement, that is suitable to the level of training and the specific nature of the professional activity; and, the guaranteed protection of the professional against incompetent evaluations and administrative whims in any disputed cases connected with his activity.

Who among pilots who have served for ten years or more has not heard of cases where a fellow serviceman has been removed from flights for the slightest "offense" ("non-regulation" shoes, for instance, or playing dominoes at the start position)? This also happened: a senior officer, visiting a regiment and noticing that it had young pilots who were not party members, ordered that the lieutenants not be permitted on flights until the question of their party affiliation was resolved. The issue, by the way, was resolved in a few days. The candidates' cards became "passes" into the sky for the young fighter pilots.

While the "party" episode belongs more to the category of the curious, the host of examples of the arbitrariness of instructors at the flight schools is not a curiosity, but a chronic indisposition in the system of training of flight personnel. Quite a few "willful" decisions are made by the methodological councils of the aviation units, endowed with the right to draw conclusions regarding the professional suitability of pilots and actually decide their fate, the flight medical commissions that have annulled more than one "pass into the sky," and aviation

commanders at all levels, who are not able to protect the pilots, as a rule, in conflict situations.

The social and domestic support and guarantees in the event of a forced departure from flight work or age-related retirement are also far from optimal. The favorable computation of time served, affecting the size of the pension, is perhaps the sole substantial achievement in this realm. The rest is gaps throughout. Other benefits, by virtue of objective reasons, are frequently not realized. The crisis in the economy, the cutbacks in defense appropriations, inflation and other circumstances are only aggravating the situation.

One unfortunately need not talk today about the optimal conditions for improving the professional proficiency of Air Forces flight personnel—the very possibility of the pilot's going up into the sky is in question. The causes of this situation are generally known, and we will thus not dwell on them here.

The absence of clear-cut prospects for the organizational development of the Air Forces in Russia and the CIS, cutbacks in flight personnel and other reasons have led to a spontaneous exodus of personnel by initiative "from below." Those who have decided to part with military aviation have made the choice voluntarily, and there would seem to be no complaints there. These are, at the same time, irreplaceable losses that will be difficult to compensate for later. New spending will be required for the training of flight personnel, and the question will come up of measures facilitating an increase in the terms of rotation and lengthening flight longevity to limits that have become the norm in the advanced aviation powers. The creation of attractive motivational foundations for flight work and a rise in its prestige will also be required, aside from additional material expenditures and purposeful organizational measures. And then the question of solid professional protections for the military flier will have to be resolved anyway. Is it worth waiting, endlessly postponing the solution of an urgent problem, aggravating an already critical situation? The more so as success in the reformation of the Air Forces is impossible without the resolution of a whole set of questions on legal, social and professional protections for the military pilot.

The breadth and delicacy of the problem does not permit the coverage of all aspects of it in one feature. We will thus consider this issue just using the example of the equivocal situation that a flight accident undoubtedly is.

The discussion of the problems of the *a priori* "guilt" of pilots who have committed preconditions to a flight accident or an accident itself has been underway for a long time now. The pilot is doubtless not omnipotent in the air, and it is futile to seek one-hundred-percent infallibility of action from him. That being so, he should have the formal right to make a mistake. Imagine yourself, on the other hand, in the role of the passenger in an airliner to whose crew that right has been granted... The flier is organically fit into an enormous aviation system

that functions according to strictly defined laws that do not always meet the interests of a particular individual. His initiative should not go beyond the requirements of the effectiveness and safety of flights. Whence, as a logical and natural result, an increase in demands toward the flight personnel.

Human capabilities, however, are far from unlimited. Flight work has moreover been deemed one of the most complex types of activity, where chance and sometimes unpredictable non-standard situations are frequent. To place responsibility entirely on the pilot for error-free actions and the guaranteed assurance of flight safety under such conditions does not seem reasonable. Reasonable arguments are unfortunately not always taken into account in life, giving way to knowingly aggressive emotional or opportunistic arguments.

The search for a solution to this contradiction has historical roots. Two approaches toward the problems of man in aviation have taken shape over the years since the time of the first airplane—the machine-centered (MC) and the person-centered (PC). The first arose as tribute to the wings that allowed man to break away from the earth. The pilot, although he looked to be some kind of god to those around, was nonetheless considered to be an appendage to the machine, a transmission link in the system of controlling it. That opinion became widespread in our country. At the same time some specialists, striving to increase the reliability and effectiveness of the aviation system, have concluded that the person should be made the focus; the aircraft is a tool of his labor. That is how the second—person-centered—approach was born.

They are in essence opposites, since they protect only "their own" elements of the aviation system, and each reflects only a part of the truth. It is thus important to understand the advocates of both approaches in order to devise a sound mechanism of professional protections for the pilot. We will begin with the fundamental contradiction—the dilemma of the right of the pilot to make a mistake.

The advocates of the MC, "command" viewpoint feel that the pilot has full professional freedom, that is, he can fulfill (if he tries) all of the requirements that are posed toward him by the guiding documents, the aviation hardware and the superior officer. He should thus be responsible for his own mistakes, and must be forced to avoid them by methods of will. The flight crews are thus given just a narrow range of "tolerances" beyond which they may not go, otherwise an emergency situation will inevitably be created. Errors giving rise to such deviations, regardless of the reasons, are impermissible. The miscalculations of a pilot that lead to mistakes are violations of the flight rules and regulations.

This viewpoint is regularly extended to the overwhelming majority of flight accidents and the preconditions to them. The pilots are made liable even for the consequences of equipment failures and unfavorable

external conditions if they could, in principle, have been countered. Even mistakes provoked by the situation are equated to a lack of discipline, with all of the attendant consequences. It is not for nothing that the saying "If you sat in the cockpit, you are already to blame" arose among the pilots—a bitter realization of the fated outcome of the battle for professional honor.

The representatives of the PC, "humanistic" viewpoint feel that the mistakes of the pilot arise in the combination of a series of unfavorable factors, and are brought about by certain causes that are manifested regardless of his will or awareness. A deviation from the assigned mode is a manifestation of certain laws of nature, the chance confluence of circumstances or an imperfect system of selection, indoctrination and training of pilots and flight support, and the pilot thus cannot be held responsible for it.

Scholars, in their attempts to deflect the blow from the pilot, put into circulation such concepts as the human (understood to mean the presence of a lack of correspondence between the requirements toward the person and his capabilities) and the personality (taking into account the specific features of a concrete individual) factors, typifying not only the potential capabilities of a person, but also their limited nature.

We have considered only the extremes of each of the approaches for the sake of clarity, and clarified that while the representatives of the "command" viewpoint, without troubling with a systematic search for the causes of a flight accident, are ready to chalk it all up to the person, the opposing side tries to justify him entirely.

In real life neither one of the approaches resolves, or can resolve, the problem of the reliability and effectiveness of flight operations and, therefore, the professional welfare of the pilot. Their forced merging, a search for a sensible compromise, is thus natural and logical. Although, as has already been noted, the MC approach predominates today. Only one out of every three or four graduates of the Air Forces flight schools, meanwhile, is in the first professional selection group and therefore fully meets professional requirements. The reliability and ergonomic engineering of aviation hardware, flight support equipment and the system for training aviation specialists and their working conditions are in roughly the same "ratios" to the stipulated norms. Whence the many disasters in our aviation, which are frequently put on the shoulders of the crew members. The pilot is thus objectively not in need of the "right to a mistake," but rather of a skilled, systematic approach to investigating any flight accident, ruling out arbitrariness and guaranteeing the repudiation of the concept of seeking out those to blame and moving to the concept of seeking out the causes. The problem of professional protections for the pilot can thus only have as an optimal solution one that takes all of the capabilities of all elements of the aviation system into account with that approach.

It must be noted for the sake of fairness that the pilot is not entirely defenseless. The adoption of the "paperwork for the procurator" was a definite achievement (true, not without reservations). Covering oneself with "papers" is often the only chance for the pilot to justify himself in the event of a flight accident. The system was "set up" from the beginning in a way, however, that made it possible to make the pilot the guilty party in a flight accident—and even a criminal—with the help of those same "papers." One can always find the vulnerable spot in his notes, after all.

The makers of the aviation hardware, the Aviation Engineering Service (IAS) and Air Forces rear support bear responsibility for the quality of that hardware and its reliability and servicing. The IAS, at the same time, protects the engineering and technical personnel—while trying, true, to squeeze everything out of them, but not giving offense to the extent possible. It would seem that there should be an official organization standing behind the flight personnel as well, defending the professional rights, honor and personal dignity of each pilot. There is unfortunately no such organization. Neither the Air Forces Combat Training Directorate, the Flight Safety Service nor senior officers can lay claim to that role to the full extent (although it is imposed on them as a duty), since they are all performing state tasks first of all, answering for combat readiness and the safety of flights. Neither the corresponding directorates and services nor the commanders are thus able to protect the flier. The streamlined hierarchical structure of responsibility of commanders for "insufficient exactingness toward subordinates" moreover impels the officers in charge to be concerned only with their own welfare.

So is there a way out? Under today's conditions, when the professional interests of the flier cannot be fully defended by the commanders, the creation of a social counterweight to inert departmental structures—along the lines of trade-union organizations—is natural and logical. This process is already underway. Various committees on issues of the social protection of servicemen and their families have begun to act. A number of organizations defending the interests of aviators in the states of the former Union have already passed through the stage of emergence.

The creation of independent unions without the interference of officers in their operation, however, is effectively impossible in the armed forces, as opposed to civilian organizations, in view of the specific conditions for the regulation of social and legal issues. Commanders will obviously support such undertakings until they begin to affect their own role in providing social and, especially, professional protections for subordinates. The protection of the pilot against arbitrariness is thus only possible for an organization whose core consists of independent people, as a rule civilians, maintaining close ties with the government, social organizations and committees, which will make it possible to influence all the structures of the aviation system, including the management of aviation enterprises, the Air Forces and

the armed forces. Such an organization should have the right of legislative initiative, be independent of state sources of financing and consist of professionals who are passionate about military aviation, for example fliers who have been discharged into the reserves, engineers and test pilots able to conduct an independent investigation of a flight accident.

The main task of this type of organization would not be to replace the state structures that are obligated to provide protections for fliers, but rather to regulate their mutual relations with the commanders and organizations of the Air Forces and create conditions under which the commander would be defending the interests of his subordinate in everything. A competent arbitrator, or even a court, should be engaged along with the commander or officer from the Flight Safety Service in determining, say, the degree of guilt of the pilot in a flight accident, especially if it is a question of his fate.

The opportunities to provide professional protections for fliers depend on more than individual commanders or the leadership of the Air Forces overall. They are also frequently connected with state policy in the realm of military organizational development. The network of flight schools has put out so many pilots that their rotation in the Air Forces should be just ten years. There cannot be any discussion of flying longevity, the protection of professionalism and the like in this climate. Conditions have had to be created in the aviation units that provide for a rotation until the age of 33-35 years old, that is, effectively when the pilot is at his prime. And the justification was always ready—the maintenance of high combat readiness. But after all, if the quantity of graduates from the flight schools were to be decreased by, say, half, the influx of youth in the top professional-selection group into the Air Forces would increase by roughly as much in percentage terms, flight longevity would increase, attitudes toward pilots—who in the concluding 10-15 years of their service will be true professionals—would improve and the number of flight accidents would drop.

Social structures protecting the interests of the military flier would obviously play a positive role in the creation of legal, organizational and executive mechanisms. Their suggestions and experience could prove useful when preparing standard documents and making the transition to contract service. The military pilot should in that case have the opportunity of protecting his own professional interests, where necessary, by appealing either to an independent social organization or to any state one. All of this, along with suitable material incentives, social guarantees and domestic amenities, will make it possible, at a minimum, to return the profession of military pilot to its former attractiveness and prestige.

### Future Use of Artificial Intelligence on Fighters Considered

93UM0241B Moscow AVIATSIYA I KOSMONAVTIKA  
in Russian No 9, Sep 92 (signed to press 29 Jul 92)  
pp 4-5

[Article by Military Pilot 1st Class Lieutenant-Colonel V. Simochenko under the rubric "Science and Tactics": "The Pilot's Electronic Assistant"]

[Text] *The considerable flow of various types of information and the time limits for processing it, along with the unforeseen nature of the course of a clash with the enemy, create certain difficulties for the fighter pilot in choosing the optimal variant for waging aerial battle. How can the mental activity of the pilot be unburdened under those conditions, thereby giving him the opportunity of realizing his creative potential?*

*One promising direction in solving this problem, here and abroad, is considered to be the use of artificial intelligence systems. The discussion will be about one such system.*

A trend toward the intellectualization of the on-board electronic equipment [OEE] of modern fighter aircraft has been noted with the growth in its computer potential, making it possible to shift some of the functions in performing the complex task of selecting the effective tactics for the waging of aerial battle from the person to the computer by using an expert airborne system (EAS), which comprises the foundation of the "pilot's electronic assistant." Such systems, operating in real time, are by rights considered to be a most substantial scientific achievement in the realm of artificial intelligence, and are currently widely employed in various spheres of human activity.

The principal merit of the EAS is its quite rapid "reaction" time—the time necessary for the identification of external influences (the image of the enemy, the constantly changing aerial situation) and the formulation of the corresponding reply (the selection of the optimal variant for actions).

The task of assisting the pilot in the principal stages of an aerial battle—the selection of maneuvers to take up a tactically advantageous position (TAP) before an attack and the evasion of missiles launched against him, the determination of the moment to launch a missile (or open fire from a cannon) against a target executing a defensive maneuver, the use of active and passive jamming etc.—is inherent in the functioning of the EAS (see figure).

Current data on the enemy aircraft (range, azimuth, heading, speed, altitude, speed of convergence or overtaking and type of jamming used, as well as the structure of the radar signal reflected from the target in polarized form) is received from the ground, other aircraft and from the on-board systems of one's own aircraft by the EAS during an aerial clash, allowing the determination of its tactical performance characteristics. They are

logically processed after comparison with a tactical description of aircraft of various types (the task of tactical identification of the target is resolved therein) in an image-identification unit, which makes it possible to determine indirectly the type of enemy aircraft and the likely variation of its armaments. That information is next received, in parallel with the characteristics of one's own aircraft, by the situation-assessment unit—the basic "cell" of the knowledge base of the "electronic assistant"—where the current scenario (CS) of the aerial battle is formulated, with one of the following flight control modes corresponding to each such scenario:

- "defense," implemented in the event of enemy prevention of the creation of conditions for the use of weapons;
- "attack from defense," determining one of the most rational control submodes: launch and homing of one's own missile, the use of some type of active or passive jamming or the performance of a defensive maneuver;
- "attack," realized when the conditions for the launch of a missile before the enemy are realized;
- "search," envisaging the performance of maneuvers for the more precise determination of the location of a target in space; and
- "position," facilitating the use of a TAP and computed on the basis of the logical structure of the realm of advantage over the enemy (one criterion of the comparative assessment herein, for example, could be the pre-emptive launch of one's own missile provided there is a sufficient reserve of power-to-weight ratio for the fighter to perform the corresponding maneuvers).

The activation unit, with a frequency ensuring the suitable reaction to the dynamics of aerial battle, analyzes the conditions for the activation of each CS. The procedure for this check is defined depending on the degree of threat on the part of the enemy—from the "defense" to the "search" modes. After the determination of the necessary CS (depending on the tactical situation), the "planner" links it with the appropriate logical algorithm.

The knowledge base of the "electronic assistant" is a list of so-called product-rules "prompting" these or those CSs, as well as frames (tables) whose slots (cells) are filled with information coming from the on-board systems of the fighter and external information sources. The simultaneous fulfillment of the following conditions, for example, is mandatory to activate the CS "attack from defense": the enemy has made at least one missile launch; reliable information is being received by the "electronic assistant" on the coordinates of the target; and, the fighter pilot has already executed a missile launch, or is prepared to do so.

The "planner," having thus "fixed" the CS, immediately issues to the pilot a recommendation for conducting the

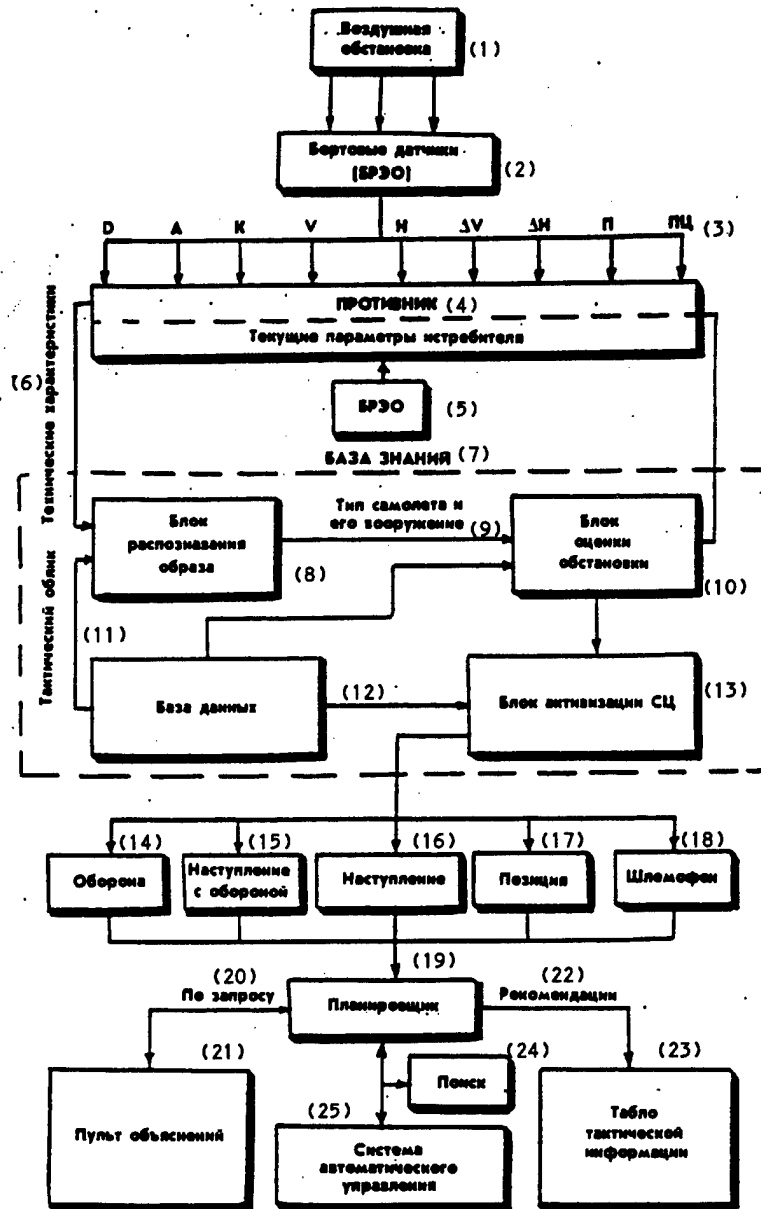

Functional diagram of expert airborne system

Key:

- |  |                                  |
|--|----------------------------------|
| 1. aerial situation                    | 14. defense                      |
| 2. on-board sensors (OEE)              | 15. attack from defense          |
| 3. current data on enemy [see text]    | 16. attack                       |
| 4. current parameters of enemy fighter | 17. position                     |
| 5. OEE                                 | 18. helmet headset               |
| 6. technical characteristics           | 19. planner                      |
| 7. knowledge base                      | 20. by request                   |
| 8. image-identification unit           | 21. explanation panel            |
| 9. type of aircraft and its armaments  | 22. recommendations              |
| 10. situation-assessment unit          | 23. tactical information display |
| 11. tactical image                     | 24. search                       |
| 12. database                           | 25. automatic control system     |
| 13. CS activation unit                 |                                  |

battle, which is presented either in the form of graphical information on the tactical-situation screen or text explanations on the corresponding display. The recommendations that are devised are received in the form of control signals by the aircraft automatic control system (with a simultaneous voice warning to the pilot) in the event of an immediate threat of a strike against the fighter by an enemy, and the control system realizes the mode of evasion of a missile (the pilot can override this command of the EAS manually). Finally, the corresponding combat algorithms are linked up with the EAS recommendation "approved" by the pilot. It is, at the same time, constantly checking the conditions for the activation of other CSs in the stipulated sequence and, if the nature of the battle changes, the tactical actions are corrected there and then.

It is entirely natural to assume that the necessity of expanding both the number of scenarios it develops and the product rules will arise over time in connection with future changes in the tactics for waging aerial battle. This would seem to be considerably easier to do than, for example, reworking already streamlined programs for devising recommendations. One need only make changes in the list of the corresponding rules in the EAS database. The "fixed" combat algorithms of the on-board computer could moreover remain as before.

The equipping of fighter aircraft of the future with expert airborne systems created on the basis of fifth-generation computers will thus facilitate a rise in the capabilities of intellectual labor of the pilot and a significant increase in the effectiveness of the use of the aviation system in an aerial battle with a no less menacing enemy.

COPYRIGHT: "Aviatsiya i kosmonavtika", 1992.

### Theoretical Refinement to Zhukovskiy Aerodynamic Theorem Proposed

93UM0241C Moscow AVIATSIYA I KOSMONAVTIKA  
in Russian No 9, Sep 92 (signed to press 29 Jul 92)  
pp 6-7

[Article by Candidate of Technical Sciences Colonel G. Karachevskiy under the rubric "Science and Practice": "Aerodynamics Beyond the Threshold of the 'Classics'"]

[Text] The subsonic area of aerodynamics is considered to be one of the "oldest," and therefore essentially one of the most thoroughly studied from the standpoint of scientific and technical fundamentals. This is conditioned in particular by the fact that effectively more than 99 percent of the total flying time on modern aircraft is logged on flights at subsonic speeds.

It would seem, proceeding from the laws of logic, that it is senseless to seek out something unexplainable namely in this realm of aviation science, the more so to discern something that is clearly contradictory to contemporary theory. Nonetheless, paradoxical as it may seem at first glance, the discussion will concern that sort of theoretical and experimental results. They have been obtained in

the course of many years of research, conducted with the aim of clarifying existing conceptions of the effects of the compressibility of a medium on the specific features of the course of aerodynamic processes.

I was impelled to the study of this problem chiefly by intuitive doubts regarding the correctness of certain provisions of classical theoretical aerodynamics, including its fundamental theorem on the lift force of an infinite-span wing (a theorem of N.Ye. Zhukovskiy that is known abroad as the Kutta-Zhukovskiy theorem). The precursors of these doubts were as follows.

That theorem says that the lift force of a section of wing of unit length under conditions of plane-parallel airflow is expressed by the dependence  $Y = \rho V_{\infty} G$  (where  $\rho$  is the density of the medium,  $V_{\infty}$  is the velocity of the undisturbed flow and  $G$  is the velocity circulation around the wing, equal to the stress of the "attached" vortex), and it has no resistance (*i.e.*  $X = 0$ ). The basic version of this theorem was derived apropos of the conditions of some theoretically idealized medium (non-viscous, non-compressible, weightless etc.). It was subsequently generally accepted, however (taking into account the corresponding proofs), that it was also valid for the conditions of a real medium, air in particular. The effects of the viscosity of the latter through the formation of the boundary layer in this instance were considered separately, with the aid of the corresponding friction resistance factor  $C_{x\text{ fr}}$ . It should thus supposedly be lacking in resistance if  $C_{x\text{ fr}}$  is not taken into account, regardless of the value of the lift force created by it under conditions of an unbroken (very small angles of attack) and subcritical (no wave resistance) airflow on the lifting wing.

We will now turn to a brief analysis of the physical essence of the processes of airflow around bodies with a regard for the kinematics and dynamics of motion of each particle of the medium taken separately. It is known that in the motion of the wing under consideration (as for any other material body of other than zero dimension) relative to an immobile medium (the air), a certain quantity of its particles are continuously in motion at varying speeds and accelerations, moving along their specific trajectories from one (initial) position to another (ultimate). Not one of those particles put into motion through the disturbance effects of the moving body (the wing) returns to its initial position therein. But insofar as each of these particles possesses an entirely definite mass, then proceeding from the basic laws of mechanics a corresponding amount of energy, equal to the work performed in a unit of time therein, should be expended to move them relative to the immobile medium.

It is entirely obvious that the total energy required to provide for such movement of an exceedingly large quantity of particles could derive only from the body itself (the wing), and should be quantitatively linked with the corresponding (to the energy expended) additional resistance of it that is not brought about by the effects of viscosity from the formation of the boundary layer (insofar as the discussion concerns only those particles of



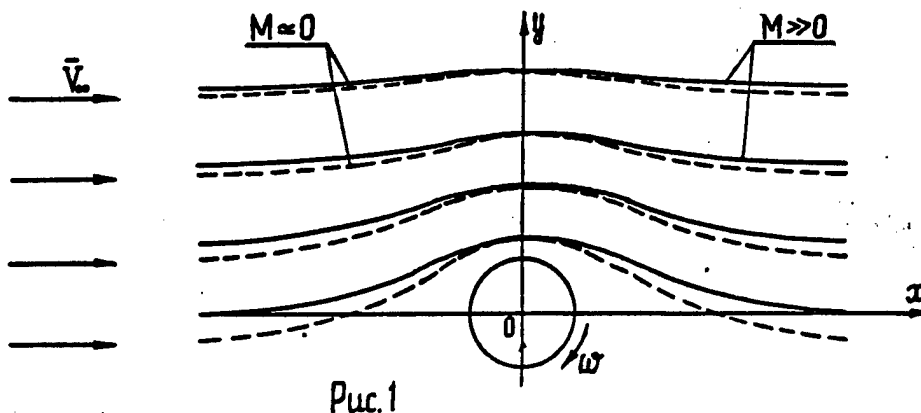

Fig. 1.

the medium that are outside the confines of it) indicated above. If one furthermore takes into account that a simultaneous increase in the acceleration of motion of virtually all particles and the length of the path of their motion occurs with increasing lift force of the wing (for example, through somewhat of a change in the angle of attack), then the quantity of energy expended for that work and the additional resistance of the lifting wing accordingly should increase in proportion to those changes. But the theorem cited does not say anything of the kind! The obvious contradiction between known theory and experience, requiring resolution through the corresponding clarification of theory, is obvious. This correction was able to be made on the basis of a new hypothesis on the nature and extent of the effects of the compressibility of the medium on the specific features of the course of aerodynamic processes.

So then, what is the essence of this hypothesis? It is commonly felt today, on the basis of conceptions that took shape as early as the last century, that at relatively low flow speeds, corresponding roughly to  $\leq$  Mach 0.3—0.4, the compressibility of the air has a negligibly weak effect on the specific features of the aerodynamic processes. A model of the flow of an incompressible liquid obtained with the aid of the so-called superimposition of the simplest flows method could consequently be used for their theoretical description. And if the structure of the airflow around, say, a rotating cylinder is modeled in that manner, one may obtain a typical picture of the stream lines of that flow (shown by a dotted line in Fig. 1) that is symmetrical relative to the vertical axis (recall that the discussion still only concerns formalized models, with the assumption of the absence of a boundary layer and wake behind the cylinder).

Various methods of approximation (Prandtl-Glauert, Chaplygin and Karman-Tzyan, among others) have been developed to account for the effects of the compressibility of the medium on changes in a similar picture, and which are typified by the fact, first of all, that the corrections for compressibility are both quantitatively

and qualitatively identical and insignificant at roughly Mach  $\leq$  0.2—0.3 (no more than 3—4 percent) and, second, at greater Mach values within the limits of their applicability, not one of these methods fails to lead to a disruption of the indicated symmetry, although the stream line itself is seemingly displaced in relation to the model of the flow of an incompressible liquid (the solid lines in Fig. 1).

Now an analogous model, but developed on the basis of a fundamentally new approach that has hypothetically been named "energy." Its chief difference consists of the fact that for any values where Mach is not equal to 0 (*i.e.* when the medium is compressible), the picture of the flow stream apropos of the cylinder under consideration will always be asymmetrical relative to the vertical axis (solid lines in Fig. 2). That asymmetry should moreover be manifested through four relatively independent effects:

- the velocity vector of the particles should have a positive rake angle ( $\delta_v < 0$ ) at points located on the vertical axis  $Oy$ ;
- $\delta_v$  should be greater in absolute value on the side of the oncoming flow than on the opposite side at symmetrically located points in space located in the regions (I—I) adjoining the axis  $Oy$ ;
- the reverse effect should be observed at analogous points located in more remote regions (II—II); and
- the local velocity of the flow should be greater in absolute value than at the symmetrically located points on the side of the oncoming flow at all points in space beyond the vertical axis (on the side of the positive direction of the axis  $Ox$ ).

And, finally, also of substantial importance, all of the enumerated effects should be manifested in quantitative terms (according to some parameters with a difference of tens of percent!) at Mach values of 0.1—0.2. They should grow significantly stronger with further increases in velocity.

Dedicated experimental research using specially created set-ups (with long rotating cylinders) were conducted in



Рис. 2

Fig. 2.

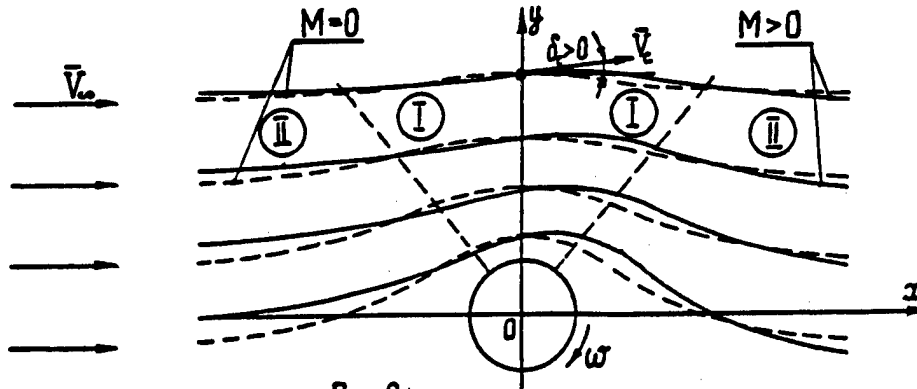

Рис. 3

Fig. 3.

order to verify these effects, which were predicted chiefly in purely theoretical fashion. The results of one of a series of such experiments are presented in Fig. 3, where the values of the local rake angles and flow velocities are indicated with a regard for the scale (for the positioning of 22 control points) and dimensionality (degrees and meters/second respectively).

Even if we proceed only from a qualitative comparison of these results with the distinctive effects indicated above, one could say that they are effectively in need of no further commentary. One may also assert that they are quite convincing and unequivocal in a quantitative regard. There is one "but" nonetheless that is well known to virtually every specialist in aerodynamics—the presence in the actual experiments of a wake behind the rotating cylinder, caused by the manifestation of the viscosity of the air through the formation of a boundary layer and a separation zone on the rear side of the cylinder.

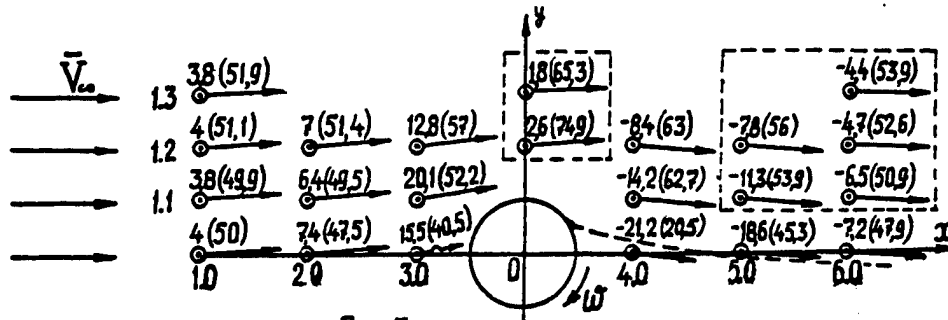
That zone in reality has considerable width at relatively low speeds of rotation ( $\omega$ ), which markedly distorts the flow even beyond the bounds of the zone itself. At certain, increased values of  $\omega$ , however, its width

decreases to minimal dimensions and, consequently, the effects of that separation zone on the external flow virtually disappear. The upper boundary of the wake is located behind the cylinder roughly as shown in Fig. 3 by the dotted line. Only point 4.0, where a strong braking of the flow occurs (more than twice as much as the nominal level), is located inside that wake. Only an insignificant braking of the flow is observed at points 5.0 and 6.0, immediately adjoining the track. This influence is negligibly slight at virtually all of the remaining points (and especially those bounded by the dotted lines), which corresponds to known conceptions.

Thus, by quantitatively assessing the research parameters at those points, it was possible to confirm with a high degree of reliability the fact that the model that has been developed is more suitable than those known already in reflecting the actual physical processes.

The loyally inclined reader is evidently now ready to pose the sacred question: "Let's say the author is right and his conclusions correspond to the truth; what can this give in concrete terms to aviation practice? A rotating cylinder, after all, is far in shape from an aircraft, and it doesn't look like aviation intends to fly in

one yet." All true. But the point is that this example is far from a particular one, as it could seem, and has a most immediate relation to modeling the processes of flow around both individual elements of the structure and the aircraft overall.

Returning to a basic theorem of aerodynamics, it should be noted that the formula for the lift force of a wing, in accordance with the model developed, takes on a somewhat different form than that of the formula of N.Ye. Zhukovskiy:  $Y = \rho V_{\infty}^2 G(1-0.5 M^2)$  (an additional multiplier has appeared!). But what is perhaps even more significant is the fact that it was possible to deduce a formula for the resistance connected with the appearance of lift force under conditions of plane-parallel airflow, that is, essentially for a wing of infinite span. For thin symmetrical shapes it has the form  $X = Y \alpha f(M)$ , where  $f(M)$  is a function of the Mach number (where  $M > 0$ ), and  $\alpha$  is the angle of attack (in degrees). This formula proved to be applicable for wings of finite span as well, conforms well to the experimental characteristics of aerodynamic shapes and ensures high precision of results when performing computational research.

The exceedingly broad realm of application of the model that has been developed—from the optimization of the shapes of wing profiles to researching atmospheric processes (typhoons, cyclones etc.)—can thus in general be stated without exaggeration.

So then, the principal stages in "conquering a heretofore unknown summit in science" were thus traversed—*theoretical studies were performed, new target formulas were deduced, convincing experimental proof was obtained, the substance of the general law main established was formulated and documents confirming all of it were composed.* It would seem that the time has come to include all interested specialists in the study, refinement and utilization of the results obtained. But the notorious "black hole effect" that has been known in science since as early as the Middle Ages—do not listen, do not publish, do not acknowledge—is triggered automatically. What, you ask, is the chief reason for this lack of acceptance? It is known to all, in my opinion—this idea contradicts what is "generally accepted," and thus "it cannot be, because it can never be."

In conclusion, the prospects for a continuation of these "anti-classical" theoretical developments. Their future looks encouraging (one would hope not to err), insofar as they rely on the main and sole criterion of the truth—experience. The process of assimilating such an idea by the masses moreover proceeds by landslide—it cannot be stopped by artificial prohibitions, directives etc. The more so as there are grounds to hope that there will be found among interested readers those who will render active assistance in accelerating that process.

COPYRIGHT: "Aviatsiya i kosmonavtika", 1992.

### Comprehensive Approach to Seeking Causes of Air Accidents Urged

93UM0241D Moscow AVIATSIYA I KOSMONAVTIKA  
in Russian No 9, Sep 92 (signed to press 29 Jul 92)  
pp 10-11

[Article by Candidate of Military Sciences Colonel (Reserve) V. Dudin under the rubric "Flight Safety: Experience, Analysis, Problems": "A Crash"]

[Text] *An experienced pilot has been killed. The commission established in the course of investigation that a failure of the hardware, and design and production shortcomings in it, led to the crash. But is that alone the reason for what happened? Candidate of Military Sciences Colonel (Reserve) V. Dudin, an honored military navigator of the USSR and a participant in the investigation of many such crashes, tries to find an answer to that question.*

The flight shift was already nearing completion when the next fighter went up into the night sky. The pilot was to perform two interceptions of an airborne training target, signified by another aircraft of the same regiment—first head-on, and then by overtaking.

The attacker, precisely following the commands of the tactical control officer, executed the hypothetical launch of a missile and successfully performed the first intercept, and was then brought to the rear hemisphere of the target aircraft. The command post report of a reduction in the distance to the target was again broadcast, and the pilot soon reported his readiness to "deliver" the weapon a second time. The nature of the replies from the interceptor had changed somewhat, it is true, in the last seconds of the execution of the second attack—a hint of concern appeared in the pilot's voice, as happens when the demands increase (repeated hearings of the tape confirmed this). But then he reported the customary "actuation" and received permission to approach the airfield, and then reported at the request of the flight operations officer what fuel he had left. This proved to be the pilot's last report. The blip of the aircraft disappeared from the radar screens a few seconds later. The remnants of the smashed MiG were found close to midnight. The pilot had made no attempts to eject...

The commission investigating the crash uncovered the dynamic of the tragedy that had played itself out in the night sky. This was facilitated by the flight data recorder, which was preserved, as well as the punctual gathering and study of the remnants of the aircraft.

It turned out that soon after the pilot had taken up the second heading, one of the rocker rods of the control system with a hidden technological flaw had broken. A spontaneous movement of the controls away from the neutral position occurred and the energetic banking of the aircraft occurred at once, which became uncontrolled rotation around the longitudinal axis (barrel roll) despite the enormous efforts of the pilot to compensate. The pilot was able to slow his speed after two complete

rotations, and even to gain a few hundred meters in altitude in the prevailing situation. But the rotation then increased again and the aircraft, losing altitude, entered the lower cloud layer. The craft was in the area of a settlement, lit by peaceful fires, after emerging from the clouds. Just a few moments passed from the start of the aircraft roll to its collision with the ground.

This flight accident was counted in the group of "failures of aviation hardware," and specifically under the "design and production flaws" column. But was it only a failure of the hardware that determined the situation that ended with a crash? Is not the prevention of losses of flight personnel impoverished by that approach?

The failure of the hardware was undoubtedly the reason that this dangerous situation arose. But its outcome, despite the undoubted shortness of time, did not happen instantaneously. After the appearance of the dangerous situation, the process of its development—on which other factors pertaining to all components of the "pilot—aircraft—environment" system had an effect, aside from the consequences of the hardware failure—is clearly discerned.

First of all, a similar situation had not been modeled during the whole period of development, production and operation of the MiG-29 aircraft that preceded this incident (more than a decade). Such a special case in flight was accordingly not mentioned in the Flight Operations Manual. The line pilot thus proved to be in the position of a test pilot, and was not able to evaluate the whole danger or, most importantly, the development trend of the situation. The absence of any reports to the ground, such as "This is 201, I am banking (rolling)...,"

also testifies to this. Events may possibly have developed otherwise after the intervention of the flight operations officer in that case.

Up until what moment did the stage of the aggravation of the hazardous condition continue? Obviously to the altitude that would provide for safe ejection, which was within the range of 150-200 meters with these parameters of uncontrolled aircraft descent. The excellent technical characteristics of the ejection seat, which was at the disposal of the pilot who suffered the misfortune, have already been confirmed in dozens of cases of successful use. Recall the unique ejection of A. Kvoruch at very low altitude in front of thousands of spectators at the Le Bourget air show. The pilot in this instance made a different decision, and an emergency situation turned into a catastrophic one...

Why did that happen? Most likely the pilot wanted to save the aircraft. His high service position, the level of professionalism he had reached and confidence in himself, on the other hand, outweighed objectivity in assessing the actual dangers. The negative attitude toward cases of abandoning an aircraft in an emergency situation ("the pilot just threw the plane away"), quite widespread among higher officers and some specialists in the flight safety bodies, evidently also played a negative role.

The proximity of a populated area, forcing the pilot to turn away from it and risking his life (there are no few such examples in the history of our aviation), also had an effect here. And, finally, the outcome of the situation was predetermined by the absence of an automatic ejection device on this type of aircraft such as exists, for instance, in the Yak-38 domestic aircraft. It has saved the life of more than one pilot in analogous situations.

The following pattern of cause-and-effect ties in the conversion of a dangerous situation first into an emergency one, and then into a catastrophic one, can be traced when analyzing this flight accident:

Initial cause	Factors aggravating the situation	Consequences
Failure of control system due to breaking of rocker. Flaw not detected during process of operation (not the only instance)	Lack of this particular special case in the Flight Operations Manual and report to the flight operations officer on what happened	Concentration of psychological stipulations only on eliminating the dangerous situation, ignorance of flight operations officer of situation on the aircraft
	Loss of control of aircraft altitude and drop to very low altitude	
	Pilot's over-estimation of his own capabilities to counter the situation, the presence of an unwarranted feeling of guilt among flight personnel for abandoning an aircraft	Failure to decide to eject
	Lack of an automatic ejection device	Death of pilot

The indicated dangerous factors, aside from the failure of the hardware, however, remained in the shadows of the one-cause approach to investigating this flight accident. This approach to investigation and, most importantly, to accounting for a whole set of operative factors in the process of development of an emergency situation, is encountered in more than hardware failures in flight. The concrete mistakes of crew members that led directly to the appearance and, especially, the accident outcome

of the dangerous situation are often not noted in the investigation reports on accidents and crashes whose causes are relegated to shortcomings in the organization and supervision of flights (NORP), or in subsequent informational and methodological documents.

It is very difficult for an awareness to push its way through of the doubtless unaccustomed phenomenon that a precondition to a flight accident, after all, is a

flight accident that did not happen—that is, a more favorable outcome to a dangerous situation in flight than one that could have happened. And sanctions should be far from paramount here—after all, they often close tightly the way both to the candor of the pilot and to a detailed study of what happened, along with the full utilization of the experience gained accordingly. A precondition moreover very often proves to be the finale (far from the worst, wholly understandably) of a situation in flight that was previously unknown and that was not predicted at one time by design engineers, aviation hardware testers or methodologists developing the combat-training courses and recommendations on piloting and weapons delivery for aircraft of the given type. So then the line pilot gets into that situation and gets himself out of it, albeit not smoothly. So then perhaps he should not be “cudgeled” to scare the others for any precondition, but it should be looked into attentively according to the principle of render unto Caesar...

Every investigator should at the same time clearly take account of the fact that the boundaries of the transition of a dangerous situation into an emergency or catastrophic one are sufficiently clearly defined only in analysis on the ground using computational data and objective monitoring equipment. They are quite hypothetical for a specific pilot in flight. The more so as a fear of consequences for the precondition he has committed frequently predominates in the motivations for his actions. Cases are not at all rare in which the pilot brings the situation in flight to a more unfavorable outcome due to this.

In concluding these personal evaluations and proposals on such important areas for raising flight safety as investigation, analysis and prevention of flight accidents, the most expedient ways of concentrating the efforts of specialists at all levels should be emphasized.

The first is deeper study of the dynamic of the appearance and development of dangerous situations in flight, which have both common general laws and a specific nature that is characteristic of each type of aviation and type of aircraft. It would be expedient here to perform research with the aim of optimizing the process of investigating and accounting for all factors in dangerous situations in flight, for their subsequent ranking and the devising of the most effective areas for the performance of preventive work in each service.

Second is the practical study by flight personnel of the prevention of the most dangerous situations due to erroneous actions, and getting out of them if they have happened anyway for some reason. A whole set of ground training—from the circulation of already existing techniques to the involvement of the newest personal computers connected with the intensive use of simulators, training films and training equipment—must be utilized here. The cutbacks in the flying time and reductions in the levels of support and organization of flights bring to the fore the personal energy of the pilot in ensuring the safety of flight operations, which will make

it possible to neutralize shortcomings in the organization of flights and their supervision, as well as in the activity of the support services.

Investigative practice and experience in averting emergency situations in flight in all branches of aviation in the armed forces, both here and in other developed nations, has confirmed that the compensating capabilities of the person on board the modern aircraft or helicopter have been far from exhausted. One must only arm the pilots with a knowledge of the existing general laws and make more efficient use of the existing reserves of the person in emergency situations. Somewhat of a change in the “thrust” of investigation is also needed at the same time, clarifying not only the fact that the pilot committed a violation, but also how he could be helped to avoid making a flight situation worse.

COPYRIGHT: “Aviatsiya i kosmonavtika”, 1992.

### Consideration of Psychological Factors in Training and Performance

93UM0241E Moscow AVIATSIYA I KOSMONAVTIKA  
in Russian No 9, Sep 92 (signed to press 29 Jul 92)  
pp 12-13

[Article by Candidate of Medical Sciences Lieutenant-Colonel of the Medical Service V. Kozlov under the rubric “Flight Safety: Advice of a Specialist”: “The Psycho-Physiologist Prevents Misfortune”]

[Text] The professional reliability of the pilot, defined as his error-free activity under any flight conditions, is one of the principal system qualities that ensures high effectiveness and safety in the fulfillment of flight assignments. It is, however, subject to the effects of many factors, the chief among which we will try to describe.

**A decline in the functionality and functional reserves of the pilot's body.** This arises in cases where the working and rest regimen, as well as the planning of the demands of flight, is disrupted. This is noted most often in intensive professional activity, on prolonged flights, after prolonged interruptions in flight operations and the like. It has moreover been established that these two factors have a certain dynamic in the yearly cycle of combat training, and which includes four periods:

the first—familiarization—runs for two months after the latest leave, and is typified by high functional reserves of the body and relatively poor quality of piloting;

the second—optimal functionality—lasts from the third to the sixth month inclusive, and is typified by the preservation of reserve capabilities of the pilot's body and the quality of flight activity at quite a high level;

the third—compensation—includes the seventh—ninth months, and is distinguished by relatively high indicators of activity against a background of a reduction in the functional reserves of the body and cumulative signs of fatigue; and

the fourth—decompensation—lasts from the tenth to the twelfth month, and is typified by the simultaneous progressive reduction of the quality of professional activity and the depletion of the body's reserves.

It should be noted that the pilot's memory suffers, and all actions (sensory, motor and intellectual) become more slowed, with reductions in the functionality and functional reserves of the pilot's body. This leads ultimately to a reduction in the reliability of the pilot in situations that require rapid reactions and correct, prompt decisions and actions. The ability to withstand the factors of flight moreover worsens sharply, while the piloting mode in combat maneuvering becomes sparing (the G-forces created are lower than assigned).

The Statoergometr test set-up, developed at the Scientific-Research Institute of Aviation Medicine, is being utilized for the purpose of predicting the ability of the pilot to withstand piloting G-forces and to develop special physical qualities in him.

In order to avert a reduction in the functionality of the pilot and increase the functional reserves of his body, it is necessary:

- to observe strictly the scientifically substantiated norms for flight burdens in a shift, week and month and the duration of breaks between sorties, as well as the time for post-flight rest with a regard for overall flying time;
- to plan flight burdens on a shift in a rational manner. Prolonged waiting for a flight is intolerable, since the readiness of the pilot to perform it decreases therein. It is most expedient to plan the most complex assignments for the second sortie; and
- to set standards for the work and rest regimen in the yearly cycle of combat training with a regard for the dynamic of functionality and functional reserves. It would be advisable to grant pilots a brief rest under the conditions of a dispensary (10 days) or a special center (15 days) in the seventh-ninth month of flight operations. If that rest is not given, the pilots should be sent for their next leaves in the tenth-twelfth months.

**Excessive nervous-emotional tension of the pilot (stress).** It has been established that the functionality of the pilot rises to the extent of increases in nervous-emotional tension compared to a state of tranquillity, but that it drops under stress. Mental and intellectual activity, as well as the performance of complex or new actions, is made more difficult at first. Mistakes in perception and lapses in certain operations appear, the distribution and shifting of attention is made more difficult, gaps in memory are observed, a feeling of confusion arises and movements become impulsive or, on the contrary, hesitation and slowness develop.

Reasons for the development of excessive nervous-emotional tension could be inadequate professional preparedness of the pilot for the exercise that he has to perform, especially in conversion training and the mastering of new aircraft, or his lack of readiness for actions in an unexpected complication of the flight situation. The specific individual features of the nervous system also have an effect.

In order to prevent excessive nervous-emotional tension, it is necessary:

- to develop the techniques and equipment for professional training of flight personnel with a regard both for the complexity of the flight assignment and the individual readiness of each pilot; and
- to conduct training on simulators with the introduction of complex situations, which will make it possible not only to work out the knowledge and skills necessary for actions under similar conditions, but also to develop psychic stability under stresses.

**"Difficult" psychic states.** This is one of the dangerous factors that accompanies the pilot in the process of professional activity and frequently leads to repeating errors. The psychic state is a concrete manifestation of the interaction of psychic processes (attention, thinking, will, emotions and the like) in the course of a flight.

Such psychic states, which do not conform to the activity being accomplished, arise under certain conditions, as a consequence of which the professional reliability of the pilot is reduced and he makes errors. These have received the name "difficult":

- dominant states** are typified by the appearance of a certain idea, under the effects of external or internal factors, that gets solidly fixed in the consciousness of the pilot and interferes with shifting his attention to a task whose resolution is required by the current situation. The causes for the appearance of that state could be diverse—important changes in personal or family life (especially negative ones), high motivation to solve some single task with the pronounced necessity of the simultaneous resolution of others, a sharp complication of the flight assignment etc.;
- premature psychic demobilization** is a reduction in the activeness of the pilot at a moment when his basic activity has not yet been completed. This psychic state is observed on flights after the completion of a complex assignment that required great psychic and physical tension. A greater slackening off than the situation permits is noted on the part of the pilot therein. The successful performance of a combat mission could thus conclude with mistakes in the landing. The manifestation of this psychic state is especially dangerous in group flights, where the pilots continue joint flight after the performance of the combat mission.

In order to prevent the negative effects of "difficult" psychic states on the activity of the pilot, it is necessary:

- to study the causes and conditions for their appearance; to master the technique of conscious adjustment of the level of one's psychic activeness with a regard for the activity being performed and the stage of the flight;
- to turn to a physician where necessary to obtain consultative and medical assistance.

**Illusions.** These are understood to mean a skewed perception of the surrounding environment. Illusions of spatial orientation, which arise most often in instrument flight, are the most widespread. These include illusions of banking, pitching up or diving, counter-rotation and upside-down flight.

The prevention of illusions in flight includes:

- regular practicing of instrument flying on real flights and in the simulator;
- the fulfillment of the basic rules of instrument flying (when approaching cloud cover, switch ahead of time to instrument flying, and when flying in "broken" clouds fly only by instruments and avoid significant slippage);
- the observation of the work and rest regimen, especially before flights.

A reduction in functionality and the functional reserves of the pilot facilitates the appearance of illusions in flight.

The following may be recommended to combat them:

- to trust the instruments completely (and to compare the information being perceived with the readings of redundant or back-up instruments in cases of doubt concerning the correctness of their readings);
- to shake the head vigorously;
- to lean the trunk forward, altering the position of the body;
- to flex the muscles.

If the condition does not pass, the pilot should report it to the flight operations officer.

**Ergonomic shortcomings in the aircraft system.** The essence of their effects consist of the fact that the psycho-physiological characteristics of the "average" pilot and his capabilities and limitations under specific conditions of activity were not taken into account in the design of some aircraft systems, and the flight personnel thus experience great difficulties in interacting with those systems.

In order to prevent erroneous actions brought about by the ergonomic shortcomings of aircraft systems, it is recommended:

- to study the ergonomic shortcomings of a specific aircraft;

- to monitor consciously, without fail, any action being performed with a system that possesses these shortcomings.

**The phenomenon of a "negative carry-over" of skills.** This is a principal cause of repeated erroneous actions by the pilot in conversion training and the mastering of new aviation hardware. This is conditioned by the fact that in conversion training for a new aircraft or helicopter—where the positioning of the equipment is different than on the type that was being operated before and the methods of working with that equipment differ—the flight personnel form a different stereotype of activity as well. Under certain conditions, however, and first and foremost when the conscious monitoring of the correctness of the actions being performed lessens, the former stereotype could be "triggered," which would undoubtedly lead to an error.

In order to prevent this phenomenon, it is recommended:

- to study the causes and conditions for its manifestation, and to have information on those systems of the new aircraft that differ from the analogous ones on a prior aircraft;
- to monitor consciously and continuously the actions being performed over the duration of conversion training and the mastery of a new aircraft, and to remember that the "triggering" of an old activity stereotype is possible.

COPYRIGHT: "Aviatsiya i kosmonavtika", 1992.

#### **New Edition of Aviation Engineering Support Manual**

*93UM0241F Moscow AVIATSIYA I KOSMONAVTIKA in Russian No 9, Sep 92 (signed to press 29 Jul 92) pp 22-23*

[Article by Colonel (Reserve) A. Poluektov under the rubric "For IAS Specialists": "NIAO-90"]

[Text] Qualitative changes in aviation hardware and methods of preparing it for flights, as well as the conditions for its maintenance and use, give rise to the necessity of periodic replacement of manuals for the Aviation Engineering Service [IAS]. The last decade was no exception. Fourth-generation aircraft have entered service with the aviation units, and are distinguished from their predecessors both by sophistication of equipment and armaments and by their operational characteristics. The standard organizational structure of aviation units has undergone changes. The mass adoption of state standards on the most varied of issues, including in the realm of operating aviation hardware, is also typical of recent years. Finally, the military doctrine of our state and the approaches to administrative activity have changed fundamentally. There were thus sufficient

grounds to replace the NIAS-78 [Aviation Engineering Service Manual], which had been in force for more than 13 years.

The new document received the name "Manual for Aviation Engineering Support for the Aviation of the Armed Forces" (NIAO-90), which was conditioned first and foremost by the necessity of bringing it into conformity with the purpose of the IAS—to support combat training and combat operations. The role of aviation engineering support (IAO) is moreover continuing to grow to the extent of improvements in aviation hardware. The tasks of the IAS during the era of piston aircraft, and even during the period of operation of first- and second-generation aircraft, were in reality effectively reduced to ensuring the good working order of the aircraft and their timely and high-quality preparation for flight. Success in performing a flight assignment was determined by and large by the flight crew, and did not depend all that substantially on the quality of aircraft preparation on the ground—if one naturally does not take into account possible failures of sighting equipment in the weapons delivery zone.

It is another matter when the discussion concerns the operation of third-generation, or the more so fourth-generation, aircraft. The presence of automated navigational and sighting systems, requiring tuning and the entry of programs on the ground, places the effectiveness of the employment of aircraft in direct dependence not only on the actions of the flight crews in the weapons delivery zone, but also on the results of the preparation of systems on the ground.

The manual, as before, consists of two parts—aviation engineering support for armed forces aviation, and aviation engineering support for combat operations. The first part is the principal one, and defines the rules for the operation and repair of aviation hardware both in peacetime and in wartime.

There are four parts in a supplement aside from the 12 chapters of the main text: 1—Duties of Engineering and Technical Personnel (ITS); 2—Guide for Evaluations and a Unified System of Indicators for the Condition of Aviation Hardware and its Servicing Equipment; 3—Standards and Instructions; and 4—Accounting Documents and Forms. And while the prior manuals reflected instructions and standards, Parts 2 and 4 of the supplement are included for the first time, and reflect the immediate requirements of the troops.

The Guide for Evaluating Aviation Hardware and its Servicing Equipment, along with the standards, contains techniques as well, which is very important for the supervisory engineering and technical personnel, especially those with little practical work experience.

Part 4 of the supplement contains samples of all the blanks and accounting forms that are used by engineering and technical personnel in their activity, while the manual itself contains references to the supplements that eases their use to a considerable extent.

The first chapter of the NIAO-90 defines the purpose and tasks of aviation engineering support for combat training and combat operations, sets forth the foundations for managing it, delimits for the first time the levels of the management system for aviation engineering support and defines the tasks of each level, as well as establishes the procedure for planning the work of IAS specialists.

The second chapter sets forth for the first time the concepts of combat readiness of the engineering and technical personnel and the aviation hardware and considers questions of the training of ITS for combat operations, supporting combat alert duty, exercises, base transfers and the performance of research checks of combat readiness.

The third chapter is fundamental. The rules for the servicing of the aviation hardware are set forth in it with a regard for new approaches. The system of technical servicing for aviation hardware using integrated technical crews is reflected, and takes its place in the NIAO-90 in particular. Practice has shown a number of advantages over the group system of servicing. The adoption of the system in the field, however, is encountering certain difficulties, about which AVIATSIYA I KOSMONAVTIKA has written more than once. The orientation of the provisions of the NIAO-90 toward it will doubtless ease this process. New sections—"Technical Servicing of Aviation Hardware" and "Monitoring the Technical Condition of Aviation Hardware"—have been introduced in the chapter that set forth promising directions in the development of technical servicing of aircraft.

NIAO-90 has a fundamentally new approach to monitoring the operation of aviation hardware. The difficulties that are encountered in the field when incorporating the provisions of Instruction No. 918 (8099) of the Air Forces Chief Engineer of 1984 on organizing the monitoring of operations on third- and, especially, fourth-generation aircraft were taken into account when devising its provisions. The discussion does not now pertain to operation-by-operation monitoring, which actually cannot be accomplished on modern hardware, but rather a system for monitoring the operations—from the interviewing of the performers to repeated checks when using the entire arsenal of monitoring equipment; from visual inspection to the use of technical devices, including computers.

The eleventh chapter, which sets forth the provisions for the operation and servicing of maintenance equipment, is new in relation to NIAS-78. This equipment is not only an essential constituent element of the infrastructure of the system for operating aviation hardware, but also has a direct effect on the level of its combat readiness and the effectiveness of its application.

The twelfth chapter—the specific features of engineering and technical personnel under the conditions of radioactive, chemical or biological (bacteriological) contamination—is laid out in a new manner. The experience in



using aviation to clean up the consequences of the accident at the Chernobyl nuclear power plant was utilized in formulating it.

The second part is presented in accordance with the provisions of the Manual for Technical Support of Troops in Operations. It sets forth the procedure for planning and implementing aviation engineering support for combat operations with a regard for the nature of them, the types of operations and the specific features of the climate and the relief of the area. These provisions are included in the NIAO for the first time.

The experience in employing our aircraft in military conflicts of recent years, first and foremost in the Republic of Afghanistan, was taken into account when describing the specific features of the servicing of aviation hardware under combat conditions. Types of work such as preliminary preparation and routinely scheduled operations were eliminated from those that are mandatory in wartime, with the principal type of preparation and monitoring of the technical condition of aviation hardware defined as post-flight preparation. Changes were also made in the rules for the performance of repairs, and first and foremost field repairs, in wartime. For example, the rights of the regimental level of the engineering and technical personnel to make decisions were markedly expanded on issues of the operation and servicing of aviation hardware, including prolonging service life, letting aircraft go up with defects that do not threaten flight safety and do not affect the performance of the assignment on the given flight, to cut back the amount of preparation of the aircraft for flight envisaged by routine technical maintenance and to use non-standard fuels and lubricants, among other things.

The supplements to the second part have also undergone significant changes. They have been supplemented with forms of reference materials and combat documents, an exposition of the procedure for developing them and filling them out, the substance of operational engineering calculations and the procedure for performing them.

Something else should also be noted. All of the terms and definitions have been presented in accordance with the GOSTs [All-Union State Standards], while the content has been substantially trimmed of general theoretical provisions. The articles are of a concrete nature and define in clear-cut fashion the rules for organizing and carrying out aviation engineering support. The ability of the compilers to refrain from excessive details and categorization in the provisions gives the commanders and chiefs the opportunity of making fuller use of the initiative of subordinates in selecting methods and techniques of work and providing for monitoring it.

The Manual for Aviation Engineering Support for the aviation of the armed forces of 1990 is thus directed at the decentralization of management over the process of technical servicing and repair of aviation hardware and the expansion of the rights of supervisory engineering and technical personnel who are directly performing the

technical servicing, first and foremost selecting the methods of carrying it out. All of this assumes the development of broad initiative among the engineering and technical personnel of aviation in the armed forces when accomplishing concrete tasks.

A restructuring of the thinking of engineering and technical personnel for the new conditions—where it is not necessary to wait for instructions on every score, and a creative approach to the solution of all problems is needed—is naturally essential therein. It is important to remember that the tasks and conditions for the use of aviation are currently changing quite rapidly, which cannot help but affect the structure of aviation in the armed forces, as well as the forms and methods of its application. The compilers, in order that the Manual meet the requirements of the present day, therefore propose that proposals from the field for improving its provisions constantly be taken into account, and that everything that is new and progressive in the practice of the IAS be adopted in timely fashion.

COPYRIGHT: "Aviatsiya i kosmonavtika", 1992.

#### **Plight of CIS Strategic Fliers Outside Russia Described**

*93UM0241G Moscow AVIATSIYA I KOSMONAVTIKA in Russian No 9, Sep 92 (signed to press 29 Jul 92) p 33*

[Article by Lieutenant-Colonel M. Syrtlanov under the rubric "Military Reform: Yesterday, Today, Tomorrow": "The Paradoxes of the New Thinking"]

[Text] *The "strategic" fliers have not betrayed the Fatherland. But what about the other way around?*

The aviation regiment of Tu-22 long-range bombers stationed close to the capital city of Kiev was included in the Strategic Forces of the CIS. Even taking into account its subordination to a unified command, however, one cannot under-estimate the consequences of the geopolitical disintegration of the former USSR, which made substantial changes in the vital activity of the military collective.

In order to understand the essence of the changes it is important, in my opinion, to clarify first and foremost just what determines the thoughts and sentiments of the fliers in the regiment today, what was up until recently called the political-moral state of the personnel. I note at once that they decided at the beginning of the Officers' Assembly of the unit to refrain from taking the military oath of loyalty to Ukraine. And it was not a matter of tradition alone that repudiated the possibility of the man in shoulder boards taking the oath twice. They reasoned in the unit that the former ritual had assumed the swearing of loyalty to all the peoples that were united by the concept of "the Soviet people." There was information, it is true, that three or four officers had confidentially expressed their devotion to the separate republic at the rayon military commissariat. But you will agree that that does not count. The more so if one takes into

account that a similar "secret" form of self-determination by President L. Kravchuk had been deemed unconstitutional.

Even the activists of Rukh, having heard out the arguments of base chief Colonel Yu. Kozhin at the time, considered them convincing and regarded his readiness to have an understanding attitude toward the request of Major S. Perts to serve in a national army on its merits. That is, the fliers experienced no political pressure whatsoever on the part of the local authorities. Normal working relations—would that they were everywhere!

So no problem, then? Not so, unfortunately. It was namely regional clashes here that aggravated to the utmost the difficult climate that had taken shape surrounding and within army structures everywhere. And while the regiment—bonded today less by their own combat purpose than by common adversity—is continuing to perform its assigned tasks successfully, it is in no way grounds to keep silent regarding the alarm concerning its future.

Just yesterday such a discussion would have started with a listing of the bottlenecks in the organization of combat training, the service of the troops and so on and so forth. But we have finally understood that the pilots live on the ground. And I will thus try to describe, in at least a few lines, the social and domestic living conditions of the fliers beyond the still "transparent" boundary, but a boundary nonetheless, of Russia.

Yuriy Kozhin has served in the regiment since 1975. Seven multiple-unit apartment buildings, stores and a kindergarten have been built in the military garrison since that time. And all nothing all the same, if this list is perceived as some kind of summing up of results. Since no one is left with any confidence in the fact that the plan for putting official and residential facilities into operation in the garrison in the future will be realized at the previous pace. Political and other differences among the authorities have doomed the officers of the Strategic Forces of the CIS to the role of stepchildren on the territory of the former republics of the USSR. It is particularly galling for the servicemen without apartments to realize their "second-class status" compared to the same unit next door, which has become part of the national army formations. The list of those waiting for improvements in housing conditions includes at least 170 families in the once elite regiment of "strategics." The burdens of barracks life are aggravated by the necessity to conserve electric power and heat, interruptions in the supply of food and goods of prime necessity and wages that are modest at today's prices. Commenting on these facts is superfluous. We will thus move on to combat training.

Yes, these people are still flying. They are flying despite all of the adversity on the ground. What moves them? A feeling of duty? Yes. Responsibility? Yes. And devotion

to their winged profession and the sky as well. Such people will not let you down. But not everything, unfortunately, depends on them.

The energy crisis that developed in the republic in the fall of last year has put the troops in a difficult position. The regiment used to receive fuel punctually, under requisitions to higher authorities, from the oil refineries of Ukraine. The situation has changed today. The crews are in the air a hundred hours a month, with a plan on the order of three hundred, as a result. This can barely provide for even a minimal level of proficiency of the flight personnel, but in no way facilitates growth in professional skills.

There is unfortunately no little evidence of this. The quantity of preconditions to flight accidents doubled in the first quarter of this year compared to the same period for last year. An unpleasant trend can already be seen. Whereas in 1991 the preconditions that were the fault of the personnel totaled 25-30 percent of the overall numbers, that figure is considerably higher today—80 percent.

Aviation technical base commander Lieutenant-Colonel A. Popov has his own concerns. People understand the worsening food in the mess hall—it has become difficult to get provisions. But how to explain and, most importantly, eliminate disruptions in the radio, lighting and airfield-technical support for flights? Concrete deeds, and not justifications, are required here, after all. The support should be sufficient, in any case, to maintain combat readiness and flight safety. They remember that at the base, and are getting themselves out of a situation that others might justly deem hopeless.

Judge for yourself. There is no possibility whatsoever of staffing the support subunits at the moment or in the near future, due to the stipulation that natives of Ukraine complete their conscript service in their native republic. The corresponding training structures are currently on the territory of other states of the CIS, which sometimes also impede the migration of mobilization resources. More than 30 airfield service vehicles were thus laid up at the ATB [aviation technical base] at the time the correspondent was working on the base. Officers and warrant officers are supporting the flights with a reduced detail of service vehicles. The forced transition to a "professional" army is still coming to the rescue. But will it really be possible to use supervisory specialists with secondary special or higher education behind the wheel indefinitely, stripping bare other sections and services of the airfield? I think the answer is obvious.

Yes, it is namely aviation, that high-technology branch of the armed forces, that is very dependent on the overall state of the national economy. The fact that the fliers of the regiment are not simply bearing the difficulties of the day in a worthy manner, but without losing optimism are advancing constructive proposals to overcome them in the future, thus elicits respect. The creation of unified

economic capacity to support the Strategic Forces of the CIS, the restoration of the previous supply system and the reckoning up and legislative assurance of social protections for servicemen and the members of their families are all essential, in their opinion. It is also heartening that the personnel of the regiment, as opposed to some hotheads, are limiting themselves today only to desires for good times, without posing the question of improving service and living conditions in ultimatum fashion. I will not take it upon myself to judge how long the restraint of the "strategics" will last. But the time has come to take steps without waiting for some other dénouement. At least for the sake of preserving the professional military cadres. It is not worth testing their patience; everyone has a limit. People who know how to love can also hate.

**From the editors:** When this material had already been prepared for press, it turned out that the regiment that is discussed here had passed, by request of Ukraine, to its jurisdiction. The Ministry of Defense of the republic, without any claims to operational control, has administratively subordinated all units stationed on the territory of Ukraine regardless of their combat purpose. And the first step in the realization of this new direction in military policy was the disconnection of special communications with Moscow here. That decision can hardly be called a constructive one, in the opinion of Chief of Staff of Long-Range Aviation Major-General of Aviation A. Proskurnin. The problems that our correspondent is talking about moreover remain topical ones to this day. The main thing is that it does not meet the principles of collective security of the CIS. We thus intend to continue the discussion of this topic.

COPYRIGHT: "Aviatsiya i kosmonavtika", 1992.

### **More History of Failed N1-L3 Lunar Launch-Vehicle Project**

93UM0241H Moscow AVIATSIYA I KOSMONAVTIKA  
in Russian No 9, Sep 92 (signed to press 29 Jul 92)  
pp 34-37

[Article by R. Dolgopyatov, B. Dorofeyev and S. Kryukov under the rubric "By Reader Request": "The N-1 Project"]

[Text] *The authors of this article took direct part in working on the project. Candidate of Technical Sciences Boris Arkadyevich Dorofeyev was a deputy chief designer and technical supervisor of the experimental development of the rocket systems at the time. He fulfilled the duties of chief designer of the N-1 rocket from 1972 until work on the topic was curtailed. Renald Dmitriyevich Dolgopyatov was the supervisor of a planning group and one of the principal design engineers and components designers of the missile from the first days of development up to the shutdown of the work. Doctor of Technical Sciences Sergey Sergeyeovich Kryukov was a deputy chief designer of OKB-1 [Experimental Design Bureau 1] and supervisor of theoretical-planning operations in creating the rocket.*

At the end of the 1950s the collective of OKB-1 was working on both military and space rockets and spacecraft. The third and fourth stages of the R-7 rocket—the principal space launch vehicle—were being created, the Molniya and Zenit satellites were being designed and tested along with automatic stations for flights to the moon, Venus and Mars, and the preparations for manned flights into space had begun.

Could a person be sent on an interplanetary flight, could a manned scientific base station be put into orbit? How could those dreams be accomplished? It was impossible without a new, superheavy launch vehicle. And they had begun working on such a vehicle, called the N-1, at the collective headed by Sergey Pavlovich Korolev. The work was being conducted in the subdivisions where the design-engineering and research departments and the departments for the power plants were concentrated, making it possible to perform the design engineering in an integrated fashion. Insofar as the R-7 rocket had already gone up, there was a natural desire to use the configuration of its components but increase the number of units and the dimensions, although everyone understood the less-than-full rationality of that approach from the standpoint of maximum weight efficiency. A layout with the transverse division of the stages, on the other hand, seemed more advanced to us. The R-9 rocket (one of these is at the entrance to the Armed Forces Museum) was being created at that time, so we also considered that configuration as well.

It must be said that Sergey Pavlovich gave the design engineers complete freedom of action at this stage, although he took part in discussing the advantages of this or that scheme. He recommended that we involve the design engineers, industrial engineers and developers of the missile systems and ground equipment in the projects, utilizing their experience for profound study of the special issues and reducing the number of "critics" when conducting subsequent stages of the work. The workers in those allied fields knew, after all, that their ideas had been taken into account from the start of design engineering.

The ranges of initial weights of the rockets (1,000—2,000 tonnes) and their payloads (40—80 tonnes) were defined quite broadly. The creation of this rocket would make it possible to solve a series of defense issues in the assimilation of near-Earth outer space, create a global system for space communications and weather service and set about research of the moon and the planets close to the Earth.

The evaluations that were made showed that the accomplishment of most of these tasks could be provided for by a launch vehicle that put a payload of 70—100 tonnes into a circular orbit at an altitude of 300 km [kilometers]. These requirements were indeed made inherent in a government decree issued in 1960, and were at the heart of the development of the preliminary design.

It was determined in choosing the configuration of the launch vehicle that the requirements for maximum weight efficiency, reliability and feasibility were best met by a scheme with the transverse division of the stages and with a unified fuel tank for each stage.

The next stage of design engineering was the selection of the fuel components. Great significance was assigned to this question, since there existed various points of view on the use of high- and low-boiling (cryogenic) components for this rocket. A thorough comparison was performed of the characteristics of the launch vehicle and the specific features of the operation, launch and stability of the transpiration of the processes in the engine, the availability of a test bed, cost, toxicity and a number of other features of various substances. A pair that was non-toxic, the cheapest and had been assimilated by production—kerosene and liquid oxygen—was selected as a result.

Engine Chief Designer V. Glushko, unfortunately, did not agree with these conclusions. He refused to take further part in the creation of the N-1. A collective from the Aviation Engines OKB headed by Chief Designer N. Kuznetsov was then brought into the development of the ZhRD [liquid-fueled rocket engine].

It must be said that about a thousand enterprises under various departments took part in the creation of this rocket system, working under the technical supervision of the collectives of the OKB-1 of rocket system chief designer S. Korolev, the OKB-276 of engine chief designer N. Kuznetsov, the NII AP [Scientific-Research Institute of Aviation Instruments] of control system chief designer N. Pilyugin, the NII KP [Scientific-Research Institute of the Cable Industry] of radio systems chief designer M. Ryazanskiy, the NII PM [Scientific-Research Institute of Plastics] of gyroscopic instruments chief designer V. Kuznetsov and the Spetsmash [Special Machinery] GSKB [State Special Design Bureau] of launch system chief designer V. Barmin. Design support for the manufacture of the rocket at the manufacturing plants was performed by the collectives of the Kuybyshev branch of OKB-1 under the supervision of D. Kozlov. The OKB-1, which came to be called the TsKBEM [Central Design Bureau of Experimental Machinery], was headed by V. Mishin after the death of S. Korolev.

A three-stage rocket with a launch weight of 2,200 tonnes and 24 engines with a thrust of 150 tonnes each (in the first stage), putting an artificial satellite payload with a mass of 75 tonnes into orbit, was selected as a result of the elaboration of the preliminary design.

The frame configuration was executed in the form of an external skin, inside of which were accommodated the fuel tanks, engines and other systems. The stages were joined by transitional trusses that made it possible for gases to pass freely in the ignition of the engines in the subsequent stages. The missile units were not transportable, and individual units that could be moved were

manufactured at the plants as a result, with the welding of the tanks, assembly of the units and the rocket overall performed at the installation and test wing at Baykonur.

The creation of a series of rockets based on the N-1 was envisaged—the N-11 using the second, third and fourth stages, with a launch weight of 700 tonnes and a payload of 20 tonnes, and the N-111 using the third and fourth stages, with a launch weight of 200 tonnes and a payload of five tonnes. The preliminary design, developed with the participation of workers from allied fields, made use of the latest achievements of domestic science, machine building, cryogenics and metals machining technology. The design also required of industry a tightening of technological discipline to a considerable extent, reductions in technological allowances for the physical and geometric characteristics of the materials and constituent items and the creation of high-strength and heat-tolerant materials, among other things. The multi-engine installation provided for the placement into orbit of a payload with the emergency shutdown of even two pairs of engines, in accordance with the design, for the first time in the practice of rocket building. This was the first time non-standard situations were addressed in the creation of this technology.

The preliminary design was developed in 1962, and the basic set of design documentation by March of 1964. The design-flight testing was planned to start in 1965. The organizational measures proposed to support the project, however, proved not to be backed up by resources and financing by the time of flight testing. The circle of tasks being resolved by the N-1, at the same time, had not been clearly outlined, and the variations of the payloads had not been designed.

The fact that a visit to the moon by man was at first in third place here is interesting. The prestige of sending cosmonauts to the moon and competition with the United States, which by that time had already been working on the realization of the Saturn-Apollo program, placed that task at the head of all the work on the N-1. The decree to launch that work came in the summer of 1964.

The result of research on the variation of a lunar missile system with the sending of two men into orbit in an artificial lunar satellite, the landing of one of them on the surface of the moon with his return to the craft orbiting the moon and the subsequent return of both to Earth was that the required payload in orbit should be 95—100 tonnes. Attempts were thus undertaken to seek solutions that provided for the receipt of such a payload magnitude without the fundamental reworking of the launch vehicle design. The principal decisions therein were a reduction in the orbit altitude from 300 to 220 km, changes in the launch azimuth, the installation of six additional engines in the central portion of the bottom of the first stage, a reduction in fuel mass through inserts in the equatorial portion of the tanks, reductions in the temperature of the fuel and oxidizer and a number of other design proposals that were projected for realization

starting with rocket No. 7. All of this made it possible to raise the payload weight to 93.5—95 tonnes, with an increase in the launch weight to 2,750 tonnes.

The flight scheme and the basic configuration of the payload had been selected by that time. This was the N1-L3 rocket-space system that was to support the making of an expedition to the moon.

The work on the creation of the launch vehicle was expanded to a broad front. More than 35 full-size experimental assemblies of the most complex and heavily burdened elements of the rocket body were developed and tested in order to assess local durability. Research began at that same time on the dynamic and aerodynamic characteristics using models, the results of which were made inherent in the design engineering of the body design and made it possible to set about the development of algorithms for the control of the rocket in flight using mathematical models of the analog-digital complexes of the OKB, NII AP, IPM [Institute of the Problems of Mechanics] and other organizations. Questions of the fundamental functioning of the engines and their assemblies were resolved at the Kuznetsov OKB at the stage of planning and design research to create the cruising engines in 1962-63, despite the lack of experience and the remoteness of the test bed.

The principle of testing individual compartments of the structure for all load cases was made inherent in the development of durability. The test bed necessary for this was built in 1967.

Protecting the bottom part of the rocket against the thermal and mechanical effects of the streams from the liquid-fuel engine cluster posed a new problem. The selection of material and its thickness were of great significance in obtaining acceptable weight values, insofar as the dimensions of the bottom of the first stage were great. The development of the materials for thermal protection and the technology for their manufacture consisted of testing various samples of heat-protective coatings for one-sided heating with simultaneous exposure to vibration according to an assigned program, and their subsequent checking in static firing tests. The flight of rocket No. 7 confirmed the high quality of the thermal protection.

The determination of the dynamic characteristics of assemblies and the missile overall was conducted on special test beds, as well as using rocket No. 1M1.

The correctness of the determination of the nominal dynamic configuration was confirmed by the flights of rockets Nos. 3, 6 and 7.

Research of aerodynamic processes was performed in aero-gas-dynamic wind tunnels, in a pressure chamber and on an operating model of the launch structure and the rocket, and was clarified in the flight of rocket No. 6 on 27 Jun 71, when it lost roll stability due to the large moment that the gas steering nozzles could not handle,

confirming the hypothesis that the nature of the appearance of the rolling moment that had not been taken into account earlier was conditioned by the specific nature of the gas dynamics of the wake flow and the dimensions of the bottom of the first stage.

The Kuznetsov OKB set about design-refinement testing of the cruising engines starting at the end of 1963, and from October through December 1967 the engines completed interagency testing (MVI).

The quality of these items was evaluated under a system for monitoring the operability of the engines according to which samples from the lot of engines delivered, selected by customer representatives, were subjected to live testing, while the rest completed only "cold" tests. Physical testing of rockets Nos. 3 and 5, however, showed insufficient reliability of the first-stage engines and the inefficiency of the quality-control system that had been chosen. The Kuznetsov OKB thus began creating a multiple-use liquid-fuel engine, quantitatively new for the times and with a considerably increased service life, on the basis of these engines starting in July of 1970. The MVI of these engines for the first and second stages was completed in September of 1972, and for the engines of the third stage in November 1973.

Steering engines newly created at the TsKBEM were installed starting with rocket No. 7, in order to ensure its stability. They passed MVI testing in August of 1972, and were then successfully tried out in flight.

The chosen configuration of multiple-engine units with unified fuel tanks provided for the hydraulic independence and autonomy of each of the engine installations, and made it possible to set about the comprehensive ground development of the engines installations (DU) of the first and second stages in conjunction with the engines under various combinations of unfavorable factors using the EU-28 and EU-29 experimental installations, created in September of 1967 using a test bed of the Kuznetsov OKB. The concluding stage in the bed testing of the DUs was testing the rocket units on the live test bed of NIikhimmash [All-Union Scientific-Research and Design Institute of Chemical Machinery], created earlier to try out the R-7 rocket and reconfigured to test all of the units of the stages of the N1-L3 system with the exception of the first. It must be said, however, that the principle of the design similarity of the units used in the creation of the rocket made it possible to extend the results of the live test-bed firings of the second-stage unit with a regard for the development of solitary DUs and to the first-stage unit. The legitimacy of that decision was confirmed by flight testing.

There were four such tests in all. The first launch was made on 21 Feb 69, while three months [as published] before that, from 21 to 27 December 68, American astronauts Borman, Lovell and Anders had orbited the moon in the Apollo 8 spacecraft. The rocket flew along the nominal trajectory for 68.67 seconds, after which a shutdown of the first-stage cruising engines occurred due

to a fire in the engine section. Each subsequent launch was made only after a careful analysis of the telemetry, quality control of the material portions and realization of measures to eliminate anything found.

The launch complex was destroyed in the second launch on 3 Jul 69 as the result of an accident in rocket No. 5. The flight testing of the N1-L3 began to take on a drawn-out nature—time was required to establish the causes for the failures and to take steps to eliminate them. Meanwhile, as is well known, the people of Earth welcomed back the Apollo 11 crew of Armstrong, Aldrin and Collins, who had reached the surface of the moon on July 21.

Political interest in our moon program receded. The question arose of increasing the level of scientific and technical tasks of the program of assimilating the moon and further utilizing the N1-L3. The TsKBEM, without lessening its attention to the development of the N-1, developed in conjunction with workers in allied fields the "Technical Proposals for the Creation of the N1-M3M System," which conformed to the "Technical Assignment" that had been received from the USSR Academy of Sciences. This modification made it possible, using two launches of the rocker with new lunar units, to make a prolonged expedition to the moon and provide for the emergency return of the crew to Earth.

The proposals envisaged accelerating the development of the N-1 project, and creating an oxygen-hydrogen booster unit for the fourth stage.

Rocket No. 6 lost roll stability in the third launch on 27 Jul 71, and the first-stage engines were shut down after the destruction of the joining of the third stage and the lead unit that had started at the 50.1 second mark.

A fourth launch was made on 23 Nov 72. Rocket No. 7 ignited. It had undergone considerable changes aimed at increasing the mass of the payload taken up and eliminating defects that had been revealed in prior testing. The area of the bottom of the first stage was decreased, its thermal-protection characteristics and the thermal insulation of the fuel tanks were improved, the mass of the gas-supply assemblies was reduced, flight control was accomplished by an on-board computer system developed by the NII AP and there were other improvements as well. Steering engines were introduced into the engine installations along with active and passive methods of fire extinguishing and mechanical and thermal protection for the instruments and on-board cable systems were improved, among other things. The measuring systems were refitted with small radio-telemetric gear created by the OKB MEI (chief designer A. Bogomolov). This made it possible to obtain additional information from the roughly 700 newly installed sensors (there were more than thirteen thousand sensors in all on this rocket).

If one recalls that the new engines for the first and second stages had passed MVI testing in September of 1972, why was rocket No. 7 launched with the old engines?

There actually was an opinion among certain leaders of the ministry to mothball it, but that decision would have led to a delay in the creation of the launch vehicle of no less than another two and a half years. And while the manufacture of the new engines was underway and the test-bed firing of the units was being performed, the launch of rocket No. 7 would verify the dynamics of flight control with the new steering engines and the essentially new control system, along with many other solutions. The State Commission, after repeated discussions, decided to conduct the launch. The rocker flew for 106.93 seconds without incident, but then the virtually instantaneous destruction of engine No. 4 occurred just seven seconds before the nominal shutdown time for the first stage, which led to the destruction of the rocket.

#### From the Reports and Conclusions of the Accident Commissions

**Rocket No. 3.** Engine No. 12 was shut down 0.37 seconds before the actuation of the liftoff contacts by false command of the KORD system, followed by the opposite engine No. 24 in accordance with logic. The flight was along the nominal trajectory until 68.67 seconds and the engines functioned normally, with the exception of engine No. 12. The vibration loads on its gas generator in launch reached 450 Gs (they did not exceed 150 Gs on engines Nos. 1 and 3), and the gas pressure measurement tube behind the turbine ("DPT") ruptured at 5.5 seconds with the spontaneous reduction of the regimen in 8 seconds and the destructions of the fuel pressure measurement tube in front of the gas generator nozzles ("DGFG") in 27.3 seconds.

A sharp rise in temperature in the area of engines Nos. 3, 21, 24, 23 and 22 was recorded at 54.5 seconds.

The KORD system issued the command to shut down all engines along the pulse channel at 68.67 seconds, due to the shorting of the 1,000-Hz direct- and alternating-current circuits.

**Rocket No. 5.** Failure of engine No. 8 when entering the main-stage regimen (0.22 seconds after actuation of the liftoff contacts).

At the time interval of -0.2 to +0.25 seconds: a) pulse effects on the body of the rocket; b) a sharp rise in temperature in the area of engines Nos. 7, 8 and 9; c) the disabling of the telemetric apparatus on engines Nos. 8 and 9.

At 0.6 seconds—KORD system command for shutdown of engines Nos. 7, 8, 19 and 20.

At 8.76 seconds—the KORD shut down engine No. 21 (opposite engine No. 9).

At 9.3 seconds—disruption of the power circuits of electrical supply.

At 10.15 seconds—shutdown of all engines except engine No. 18.

At 14.5 seconds—actuation of emergency rescue system of mock-up of descent craft.

At 23 seconds—the rocket fell onto the launch pad.

The cause of the engine failure was the ignition of an oxidizer pump and its destruction.

**Rocket No. 6.** All of the engines operated normally. Abnormal course of the rocket roll-stabilization process was noted from the start of the flight. The discrepancy in roll increased continuously and reached 14° by 14.5 seconds, despite the countering effects of the steering nozzles, which were against the mechanical limits by 7.5 seconds (45°).

The normal operation of the gyroscopic instruments was disrupted at 39 seconds, and the rocket was not stabilized on all axes in later flight.

The destruction of the rocket and space system in the area of the junction of the third stage and the main unit began at 47.8 seconds.

The engines were shut down by emergency command from the end contacts of the gyroscopic instruments after removal of disabling at 50.1 seconds.

The most likely cause of the accident was the effects of the aggregate of destabilizing moments that had not been revealed or taken into account earlier when selecting the available controlling moments for roll.

**Rocket No. 7.** The flight proceeded normally to 106.93 seconds. The basic parameters of the design, engine installations, control system and on-board electrical supply were at the assigned limits.

Analysis of the possible causes of the accident showed:

- the accident of rocket No. 7 occurred as the result of damage in the tail section of unit A, caused by the destruction of engine No. 4;
- the assumption of the destruction of the engine for internal reasons does not contradict the data from telemetry for engine No. 4 and test-bed firing, the results of an inspection of the material portion and the physical picture of the development of the accident;
- the assumption of the loss of seal integrity for the main lines feeding fuel to the main and steering engines before the start of the accident is not confirmed by the telemetric data.

The cause of the accident was the burnout of an oxidizer pump.

\* \* \*

The next launch was projected for the fourth quarter of 1974. All of the planning and design measures resulting from an analysis of the launch accidents had been realized by May on rocket No. 8, in order to ensure the survivability of the rocket.

The installation of the new multiple-launch engines began. The collectives of the plants, design bureaus and enterprises that took part in the project prepared the rocket for its flight with their prior enthusiasm, because they had grounds to believe in the positive outcome of the launch. But the newly designated head of the TsK-BEM—which had been converted into the Energiya NPO [Scientific-Production Association]—Academician V. Glushko, ceased work on the N-1 launch vehicle in May of 1974.

The government decree on the shutdown of this project and the write-off of the expenditures came only in February of 1976. The Americans had concluded their moon program four years earlier with the flight of the Apollo 17, having invested about 25 billion dollars in its realization. It must be said that despite the immensity of the project, the total expenditures for the N1-L3 totaled 3.6 billion rubles as of 1 Jan 73, of which 2.4 billion were for the N-1. The total estimate of planned expenses, including 16 flight prototypes (Nos. 3—18), had been 4.97 billion rubles.

It is interesting to recall, for the sake of comparison, that roughly the same amount of funds were expended in the first stage of modernizing the Gorkiy Motor Works in connection with the creation of a diesel truck. Here is what was written about this in the newspaper TRUD on 11 May 91: "The construction project has already cost the country 2.5 billion rubles. Another billion will have to be invested..." Even the most prejudiced critic of "excessive" expenditures on space would probably understand the difference in complexity of these two projects. It must be said that working under the conditions of tough financial and material restrictions, Sergey Pavlovich Korolev was constantly concerned with having the developers seek out ways of making maximum use of the scientific and technical potential of the country and the most efficient (from an economic standpoint) engineering, design and technological methods of creating the systems and developing them. That approach by the Chief affected to a considerable extent the utilization of the principle of design similarity of units, the selection of configurations for the units, the capacity of the engines and the fuel components, flight control by throttling the engine thrust, the transfer of the process of assembling large rocket assemblies directly to the technical position of the missile range and many other components of the process of creating the new system. This can explain, to a significant extent, the relatively low cost of the launch vehicle.

Science, technology and production in the realm of rocket and space technology take unexplored paths. Scientists and engineers create a host of new things that can be employed to advantage in the national economy "along the way" to the assigned goal. That is perhaps namely what should provide a considerable portion of the economic impact from space activity, but the innovations are still being too little used. Their adoption is being impeded by parochial, departmental barriers first and foremost. It is long since time to put an end to

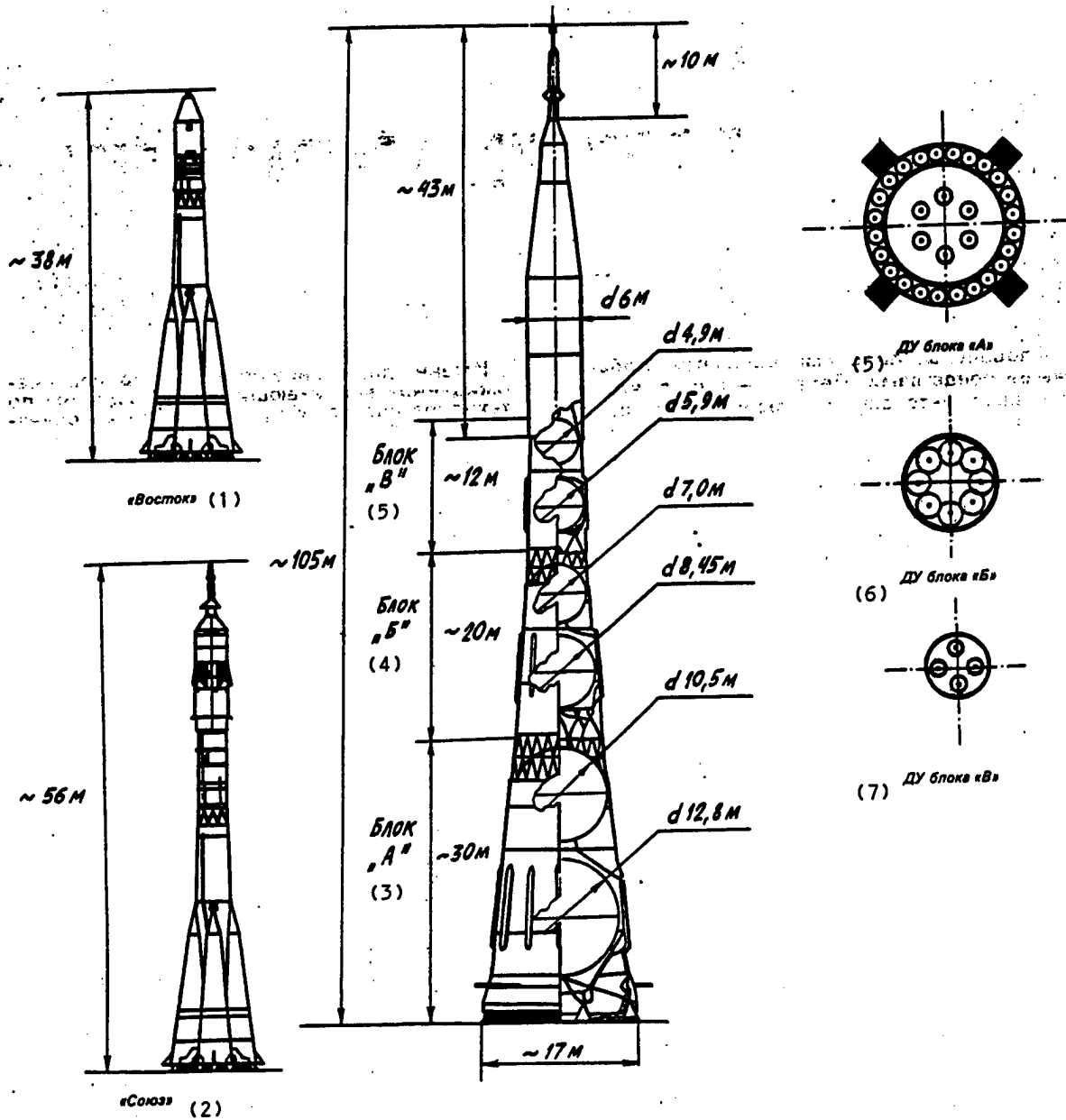

- Key:
1. Vostok
  2. Soyuz
  3. unit A
  4. unit B
  5. unit C
  6. engine installation of unit A
  7. engine installation of unit B
  8. engine installation of unit C



discussions of the necessity of developing space science. We must work more energetically to utilize its achievements.

#### Technical Data on the N-1 Rocket Launch Vehicle

Overall length, meters	105
Length without payload, meters	65
Maximum diameter, meters	17
Number of stages	3
Launch mass, tonnes	2,700
Payload mass in reference orbit, tonnes	95
Thrust of engine installations, tonnes:	
first stage	4,620
second stage	1,430
third stage	164

COPYRIGHT: "Aviatsiya i kosmonavtika", 1992.

#### Plan to Counter Ozone-Layer Destruction With Space-Based Mirrors

93UM02411 Moscow AVIATSIYA I KOSMONAVTIKA  
in Russian No 9, Sep 92 (signed to press 29 Jul 92)  
pp 38-39

[Article by Lieutenant-Colonel V. Maksimovskiy under the rubric "A Look at a Problem": "Ultraviolet Versus... Ultraviolet"]

[Text] *Global problems are solved using global means. The former are what affect the interests of all people on earth, that which no single country can surmount, and where a unification of the efforts of many nations is needed. The latter are, first and foremost, the opportunities that space science gives us.*

*It is namely an understanding of the acuity of the questions that "unexpectedly" arise before mankind, proceeding along the technocratic path of development, that brings together the seemingly most varied of people. Our story is about such a group of like thinkers and the method they have proposed for solving the problem of the "ozone holes."*

They are united by the idea of settling people on other planets. But that is a quite remote prospect, and one must not forget about today while occupied with it. That is why they have set themselves the aim of finding a way of averting the loss of atmospheric ozone. Who are they? Chemist, Academician of the Russian Academy of Sciences and Chairman of the Russian division of the Ecoforum for Peace organization, Boris Nikolayevich Laskorin; architect and ecologist, specialist on settlements in zones with extreme natural and climatic conditions, Candidate of Art Studies Dzhangar Badmayevich Pyurveyev; engineer in the realm of missile and space technology of the Mashinostroyeniye NPO

[Scientific-Production Association], Candidate of Technical Sciences Georgiy Fridrikhovich Resh; and, physicist and leading scientific associate at the NII [Scientific-Research Institute] of Applied Mechanics and Electronics of the Moscow Aviation Institute, Candidate of Physio-Mathematical Sciences Arsen Sergeevich Sokolov.

Why has prompted them to seek a solution to this problem? The answer is simple—the threat to mankind that is concealed in the so-called ozone hole. Although there is much that is not clear in this phenomenon from a scientific viewpoint, they feel that steps must be taken now; we could be too late while we are looking for the root causes, and an ecological catastrophe could develop. The main thing is that the proposed method not lead to negative collateral phenomena and be at all times under the control of man. The threat is that as a result of the depletion of the ozone layer in the atmosphere in these areas, the ultraviolet light coming from the sun will be weakened to a considerably lesser extent. That leads to irreversible changes in the plant and animal worlds in the oceans and on land, since it is obvious that all living things have adapted to the prevailing, quite stable conditions over the time of their existence. This pertains to the power of ultraviolet emissions as well. An increase in them would have an appreciable effect on the vital activity of living things. Organic nature will not have time to react to the sharp changes, and they are of a man-made nature in our times—that is, they are a consequence of the "creative" activity of people striving to create for themselves more conveniences more quickly.

Just what is an "ozone hole"? If we are to speak precisely, then there are few such places where the ozone layer is unusually small in the atmosphere, and their number varies. They can differ in size and the stability of the zone. The largest and most persistent is located over Antarctica. Constant observations that have been conducted since 1956 have made it possible to conclude that this "hole" is growing and the layer of ozone in it is thinner and thinner, although the process is a complex one. The layer is thinner in odd years than in even. A steady worsening of the situation, however, has been observed since 1980.

Why is Antarctica so "unlucky," and what is so harmful about it anyway, since it is, after all, a virtually lifeless expanse? The result in nature is determined by the correlation of forces developing in opposite directions. In our case, the appearance and disappearance of a molecule of ozone. Their formation occurs under the effects of ultraviolet emissions from nitrogen dioxide (NO<sub>2</sub>), providing almost entirely for the "production" of atomic oxygen. Ozone (O<sub>3</sub>) forms as the result of its combination with oxygen molecules. That is, the better illuminated a given area of the atmosphere and the larger the amount of the aforementioned substances in it, the thicker the ozone layer will be. That is the "idea" of nature—the more solar illumination there is, the better the protection against its destructive ultraviolet.

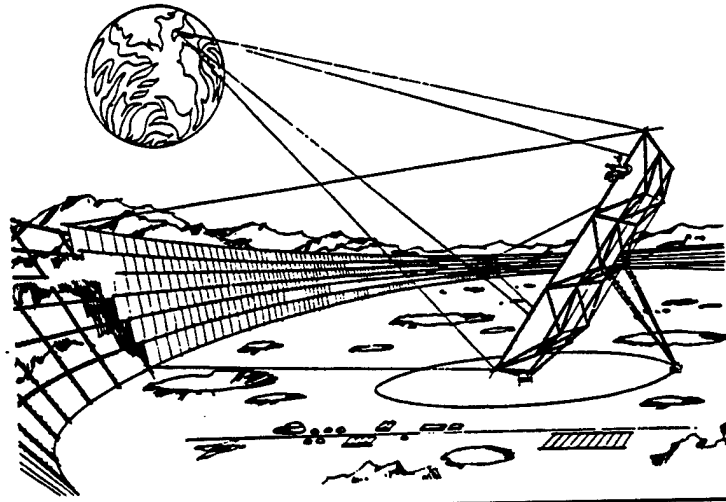

All of the basic influencing factors—both dependent and not dependent on people—are operating in the expanse over Antarctica. It is well known that the polar regions are effectively not illuminated by our star for several months. That means there is no light and little heat. The atmosphere cools, and the temperature in the stratosphere drops below 195°K. That leads to the formation of stratospheric clouds, first and foremost through the crystallization of water vapor and nitrogen compounds. The authors of the proposal feel that the known link between their appearance and the formation of “ozone holes” could be explained by heterogenic (in the solid particles of the clouds) freezing of the  $\text{NO}_2$ —the loss of the parent molecules essential for the birth of ozone. Matters are aggravated by the fact that a steady vortex forms over the continent during the polar night that prevents the exchange of air with the outer atmosphere, and the air is thus not heated through atmospheric currents.  $\text{NO}_2$  and  $\text{O}_2$  moreover do not enter it from the outside. The processes of destruction of the ozone are thus strengthened by thousands of times, and the layer where it is thinnest is thus right in the middle of the vortex.

There are man-made factors as well. Additional thermal insulation of the Earth from the surrounding space, as it were, also occurs as a result of the greenhouse effect, owing to which the lower layer of the atmosphere—the troposphere—is heated more actively while less heat is radiated by our planet into space at the same time. The overlying stratosphere, that is, where the ozone layer is located, is cooled more and more to the extent of the development of the process. The active campaign to ban the use of freons (they are called *khladons* here)—hydrocarbons containing fluorine and chlorine—is also memorable to all. These substances are employed in enormous quantities in refrigeration units, aerosol cans, dry cleaning and the cleaning sections of plants and factories. They are very convenient for those purposes, but being volatile, they end up in the stratosphere and, under the effects of sunlight, release chlorine that destroys ozone.

The “ozone hole” that has formed over Antarctica draws in ozone from adjoining regions, reducing its quantities in zones over Australia, Japan, Oceania, South America and southern Africa. This leads, in particular, to a significant worsening of the conditions for the growth and reproduction of phytoplankton—the foundation of the food chain for the inhabitants of the seas and oceans. The quantity of illnesses among people with skin cancers, cataracts and immune deficiencies increases. Roughly ten percent of the ozone disappears from the Earth’s atmosphere in the “hole” over the ice continent. That is why this process affects every living thing on our planet.

It must be said that the polar night also comes down over the Arctic, but there is no such cooling of the stratosphere and the sections where the ozone layer thins are small and unstable, since the decisive factor there is the lack of an enormous territory covered with solid ice.

What can be done? If we obtain less energy burning fuel, for instance, there will be less of a problem with the greenhouse effect. If we get rid of freons, that would also be good. But results cannot be expected soon from those measures, since these substances are very long-lived—they do their “dirty” work for 50 to 100 years, and there are already too many of them in the atmosphere.

And what if we were to do the seemingly most difficult thing—help our sun improve the illumination of the polar regions? The introduction of additional solar energy from space into the atmosphere would make it possible to have an effect on two factors at once—to avert the freezing of the  $\text{NO}_2$  molecules and to intensify the photochemical transformation, with the formation of ozone. That illumination must be made during the period of polar night, ascertaining the place of the greatest cooling (the stratospheric clouds form there), and the emissions directed right to there. The atmosphere over the territory with the weakest ozone layer

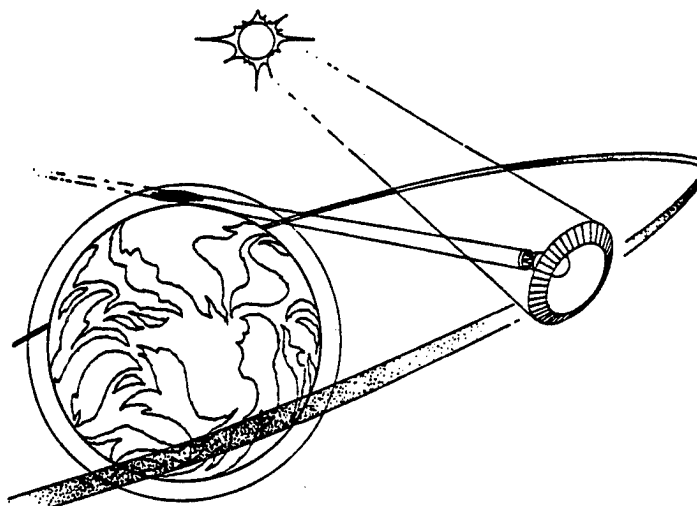
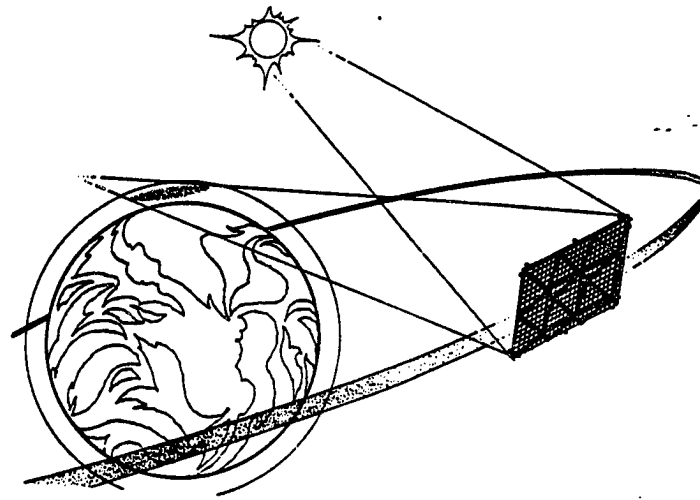

must be illuminated during spring for the southern hemisphere. The appearance of a "hole" anywhere can be prevented in that manner.

Calculations performed at the Mashinostroyeniye NPO by Candidate of Physio-Mathematical Sciences A. Vartanyan have demonstrated the effectiveness of the proposed method. The mathematical model takes into account the photochemical decomposition of the molecules of oxygen, nitrogen dioxide and ozone, the processes for the formation of ozone and its destruction in chemical reactions with atomic oxygen and harmful impurities, and the recombination of atomic oxygen into molecular. The likelihood of the birth of oxygen molecules proves to be substantially increased. Directing the emissions over a selected terrain along the chord of the Earth's atmosphere is the most advantageous herein.

This approach almost rules out direct solar radiation in areas with lessened ozone layers.

The authors propose the realization of this plan with the aid of satellite mirrors placed in orbit (see figures). Such specialized spacecraft could have a long active existence, probably limited by the time that the properties of the reflectors are preserved. Such installations could be placed in fixed positions on the moon as well, to the extent it is assimilated.

This is in the future. Today, in the opinion of the proposal's authors, it is essential to carry out concrete studies and set about the realization of ideas based on existing technologies. Thin-film reflectors, as are under development for the spacecraft for a flight to Mars (AVIATSIYA I KOSMONAVTIKA, 1992, No. 3), and the Energiya launch vehicle should be used first and foremost. Time does not wait.

COPYRIGHT: "Aviatsiya i kosmonavtika", 1992.

### Soviet Air Advisor Recalls Vietnam Tactics Against B-52 Bombers

93UM0241J Moscow AVIATSIYA I KOSMONAVTIKA  
in Russian No 9, Sep 92 (signed to press 29 Jul 92)  
pp 42-43

[Article by Hero of the Soviet Union Major-General of Aviation (Retired) M. Fesenko under the rubric "Aviation in Local Wars": "The Vietnam Syndrome"; continued from Nos. 7 and 8]

[Text] The "Fortress" Was Taken by Skill

The combat operations of American aviation in Southeast Asia were being conducted with one aim in December of 1972—to break the armed resistance of the Vietnamese people and force the government of the DRV to sign an agreement to quit the war. The Linebacker 2 air operation was carefully planned and conducted in accordance with those intentions, and its foundation, as has already been noted, was group strikes by B-52 Stratofortress (translating as "a fortress in the stratosphere") strategic bombers. The so-called carpet-bombing method, which consisted of a build-up on sections of the area being hit (each aircraft carried 27 tons of medium-caliber bombs on board on the main and auxiliary racks), was employed. "Scorched-earth tactics" is the way the foreign press described the actions of U.S. aviation in Vietnam.

The actual course of the air operation and its results were quite widely covered in our military press. It will nonetheless perhaps be of interest to the reader to learn some details of the aerial skirmishes between the North Vietnamese fighter pilots and the American pilots, and especially the nighttime duels with the crews of the B-52s.

The fighters of the VPA thus made 31 aircraft sorties (27 in MiG-21s and 4 in MiG-17s) over the 12 days of the Linebacker 2 operation—which by tradition began with strikes by the aggressor against airfields in the DRV—and fought eight aerial battles in which two B-52s, four Phantoms and one RS-5C reconnaissance aircraft were shot down with the loss of three MiG-21s.

The Vietnamese, in accordance with the recommendations of the Soviet military specialists, gave priority to tactics of one-time solo intercepts without getting drawn into protracted maneuvering battle with the enemy, in order to most fully realize the combat capabilities of the MiG-21 under conditions of a numerical superiority of the enemy in the air and his reliable radar monitoring of the area of combat operations. The system of long-range radar notification that we created made it possible to detect the B-52s at high altitude at distances of up to 350 km. Readiness times of 5—6 minutes in the daytime and 6—7 minutes at night were thus defined for the MiG-21 crews.

The MiG-21 pilot usually took up a start position far behind the target and then, getting the aircraft up to the

fastest possible speed, converged with the target in concealed fashion, made a rapid missile attack and immediately headed off in the direction of its airfield by the shortest route.

Here is how events transpired in three night clashes between MiG-21 and B-52 crews.

On December 19, on the first day of the operation, an alert duty aircraft from the Noi Bai airfield went up to intercept a group of strategic bombers being escorted by Phantoms. Reaching an altitude of 6,000 meters in maximum engine operating mode, the pilot turned toward the target on command from the ground and detected it by the turned-on wingtip navigation lights (ANOs; the B-52 crews left them on when flying at night in order to maintain the assigned spacing and distances between aircraft). They were ahead and above, a little to the right by heading, at a distance of 10—15 km.

Reporting to the CP the establishment of visual contact with the target and receiving the order to destroy it in reply, the pilot turned on his afterburners, jettisoned the external fuel tanks and came around to a combat heading with a simultaneous climb to the altitude of the "fortresses." Reaching the range for launching a missile against the target, the pilot turned the RP-21 sight to emit by command from the CP (against the accepted rules), which gave him away; the crew of the bomber immediately turned off the ANOs and employed active electronic jamming, from which the blip on the RP-21 screen disappeared. The pilot reported the situation but continued to converge. Some 30—40 seconds after the start of the attack he felt the bursts of missiles, clearly launched by the Phantom escorts, close to the aircraft.

The Vietnamese pilot, executing an anti-missile maneuver with a descent, was forced to curtail the assignment and return to his airfield. One wheel of his aircraft went into a crater from an American bomb, and he suffered an accident while landing on the runway.

Pilot Pham Tuan, a future cosmonaut of Vietnam, went up from the En Bai airfield to intercept a B-52 at 2202 hours on December 27. After gaining an altitude of about 6,000 meters, without turning off the afterburners, he detected a bomber from its lit ANOs. Without losing sight of the target, Tuan made a planned maneuver with a bank of 40 degrees at a speed of 1,200 km/hr. Coming behind the B-52 at a range of 2,500 meters, he began to converge with it, with his sight moreover not turned on to emit, and made only a rough training of the weapon by visual sight. After the signal for target lock-on by the missile homing heads was received, the pilot pushed the trigger of the firing button. Two missiles fired in sequence hit the target. Tuan broke off the attack with a quarter-half roll and split S to 3,000 meters, and then landed safely at his airfield.

The next MiG-21 fighter from the alert duty forces went up at 2138 on December 28 from a field airfield that had not been subjected to bombing by American aviation. At an altitude of 7,000 meters, the pilot reported to the

vectoring station that he was observing the lit ANOs of a bomber cruising in formation at 10,000 meters. At the moment the interceptor started a planned maneuver the crew of the B-52, unexpectedly for the attacker, turned off the ANOs even though the RP-21 had not been switched to emit (the Americans were evidently listening to the airwaves and were able to warn their pilots of the danger in time). After that report of the MiG-21 the blips of both aircraft fell off the radar screens of the vectoring station. Fragments of the fighter and the bomber were soon discovered on the ground close to each other, which confirmed the version of an aerial collision of the aircraft.

U.S. aviation, according to information from the American military press, lost 15 strategic bombers during the night raids that were carried out within the framework of the Linebacker 2 operation (13 of those are credited to the soldiers of the VPA PVO). The Vietnamese command officially reported the destruction of 34 "fortresses."

Such a deplorable result was not, however, unexpected for the U.S. Air Force command, since in the course of preparing for the operation two percent combat losses of the B-52s had already been planned proceeding from the ratio of the number of aircraft shot down and the overall number of aircraft sorties made. The calculations of the Americans proved to be quite accurate—15 and 739 respectively.

I would note the following in relation to the nature of the activity of Soviet pilots in Vietnam. An American journalist expressed the assumption in a discussion with me that there were supposedly cases where our pilots had taken direct part in air battles over Hanoi and Haiphong. I had already talked about the fact that the group of Soviet military specialists included instructor pilots who trained their Vietnamese colleagues in flying, primarily in the area of their base airfields in trainers. They frequently got into altercations against their own will. I will relate one such incident.

The crew of a MiG-21US—a North Vietnamese pilot and a Soviet instructor, coming in for a landing after having practiced flying techniques in the practice area—received a warning from the flight operations officer of the appearance of a flight of Phantoms at a range of eight kilometers from the airfield (they had not been detected in good time by radar due to their low altitude) on 11 Sep 72. The MiG had only 800 liters of fuel left in its tanks by that time. The command came from the ground to get away from the strike, after which the instructor pilot, so as to break off the enemy attack, executed a roll with slip. The attempt was successful.

Subsequent events developed as follows. The first pair of F-4s gained altitude and took up a waiting position. The pilot of the MiG-21US at that time made evasive 360s with afterburner, in the process of which his aircraft was attacked twice, but the missiles launched by the Americans missed in both cases and self-destructed. A third

attack by the enemy also proved unsuccessful. The flight operations officer, observing the course of the battle, was constantly informing the instructor of the slightest changes in the aerial situation. And it was becoming more and more critical for the crew with every minute.

Attacks came from the Phantoms again, but in reply the trainer made afterburner 360s right at the ground, at an altitude of 50—80 meters. With just 100 liters of fuel remaining the instructor, having exhausted all possible defensive variations, decided to bail out of the aircraft with the pilot, and put the aircraft into a climb. But the engine stopped at an altitude of 500 meters, and yet another enemy attack came at the same moment; the missile ripped into the tail section of the fuselage. The crew of the trainer was fortunately able to eject safely...

Returning to the events of December 1972, I would like to cite as an example yet another clash, the reversal of fortune of which was unusual, in my opinion, and makes it possible to judge the diversity of tactics in the combat application of the MiG-21.

A pair of alert duty fighters went up from the Noi Bai airfield during the day on December 28 to repel a raid by the aggressor's tactical aviation, and were heading toward the line of engagement at an altitude of 300 meters. The pilots turned on their afterburners and went into a climb two minutes after takeoff, on order from the CP. During a subsequent turn, when shifting formation, the wingman detected a flight of F-4s ahead at a range of eight kilometers, and requested permission from the lead to attack. The American pilots obviously were not expecting an attack at that moment, and were thus late in taking effective counter steps. One Phantom was shot down as a result.

After the attack, when the wingman began to come up alongside the lead, the latter noticed another pair of F-4s intending to enter the battle. He disrupted their battle formation by energetic counter maneuvers and was cut off from his wingman, of whom he lost sight. Two separate dogfights were joined. The lead was able to break away from the enemy by a concealed dash toward the ground, while the wingman remained in contact and shot down another Phantom. But his own aircraft was seriously damaged while trying to disengage by fragments of a missile that exploded just a few meters away from the fuselage, after which the pilot ejected safely.

Two against six! That disposition of fighter forces between the opposing sides was unfortunately common before a battle in that air war. It was difficult for the Vietnamese pilots in dogfights, due to their inexperience in staying in contact and covering each other. Their division into lead and wingman was thus of a quite hypothetical nature, and reflected more just a way of arranging the battle formation without the delimitation of concrete duties among them. Any pilot in the VPA could take the initiative in battle at any moment and be the first to attack an enemy. And that was despite the fact that every other rank-and-file Vietnamese pilot had just

450 hours of overall flying time in his "pot"! They fought selflessly and purposefully against the acknowledged American aces. (*Conclusion to follow*)

COPYRIGHT: "Aviatsiya i kosmonavtika", 1992.

### Comparison of ZMS2 and KC-135A Tanker Aircraft Data

93UM0241K Moscow AVIATSIYA I KOSMONAVTIKA in Russian No 9, Sep 92 (signed to press 29 Jul 92) pp 46-47

[Article by V. Ilin under the rubric "Information for Reflection": "Tanker Aircraft"]

[Text]

*The long-range bomber was taken as the basis for the creation of tanker aircraft in our country at the beginning of the 1950s. It was felt to be more expedient to develop special aircraft in the United States.*

*That in particular is what conditioned the entry into service of the ZMS2 (in the USSR) and the KC-135 (in the United States).*

#### ZMS2

**Crew.** Seven men.

**Dimensions.** Wingspan of 53.14 meters, area of 351.78 m<sup>2</sup>, sweep angle of 34°48'; length of aircraft 51.30 meters (without refueling boom 48.76 meters), height 11.50 meters; maximum diameter of fuselage 3.50 meters.

**Mass.** Maximum takeoff mass 190,000 kg [kilograms], normal landing mass 105,000 kg.

**Flight characteristics.** Top speed 910 km/hr [kilometers/hour]; effective ceiling 12,250 meters (at normal takeoff mass); maximum flight range 9,440 km (with delivery of 40,000 kg of fuel in flight, 4,000 km); liftoff speed 310 km/hr, landing speed 210 km/hr; maximum operating G-forces of 2 (at flight mass of 140,000 kg).

**Engines.** VD-7B turbojet engines (4 x 13,000 kgf).

**Armaments.** Six AM-23 cannons in three turret installations with remote control (aiming by commander of the fire installations and the rear gunner).

**Equipment.** Navigational scan radar, gunner's aiming radar, enemy radar illumination warning set, automatic chaff dispensers.

**Status.** In service with the Air Forces since 1955, produced at the aircraft plant in Kazan.

**Additional information.** The first experimental tanker aircraft was created at the OKB [Experimental Design Bureau] of V. Myasishchev, and was based on the M-4 strategic bomber. Work on the bomber program began in 1951, and the first flight of an experimental prototype of the M-4 took place in 1953; series production started in

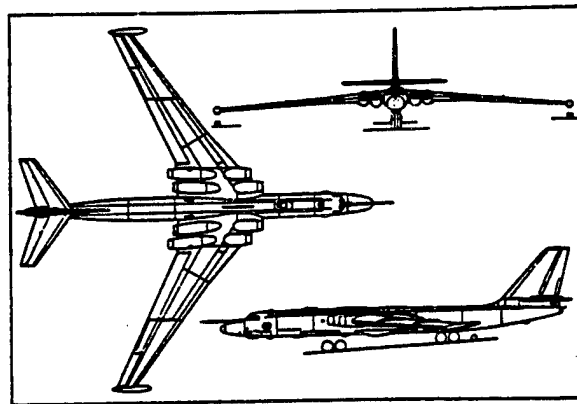

1954. The aircraft was intended for strategic bomber strikes, but the insufficient economy of the engines limited its flight range with a payload to 8,000 km. Work thus started on a specialized aircraft for aerial refueling simultaneously with the development of an improved version of the bomber with more economical bypass engines and a new wing under those conditions. The bomber and the tanker aircraft were to have identical designs and flight performance characteristics, which would ease their servicing in the line units and their joint flights in the refueling process.

The modified ZM (M-6) bomber was created in 1955 and was followed by the standard ZMS2 tanker aircraft for it, distinguished by the presence of refueling equipment in the bomb bay (the analogous route was chosen in Great Britain as well, where tanker aircraft versions were created on the basis of the Handley Page Victor, Avro Vulcan and Vickers Valiant heavy bombers). The "drogue—probe" method of aerial refueling has been adopted in the CIS (as in the aviation of the U.S. Navy and the air forces of Great Britain, France, Italy, China and a number of other nations), where the aircraft being refueled inserts a boom into a funnel at the end of a flexible hose extended by the tanker aircraft. The U.S. Air Force practices the method of refueling using a telescoping boom (a boom on a movable installation is lowered from the tail portion of the tanker and, controlled by an operator, enters a special socket on the aircraft being refueled).

The M-28 military-transport aircraft was developed (but was not built) on the basis of the ZM, and had two decks and a cargo ramp. A high-altitude version of the ZM bomber was also studied. The decision was made in 1960 to shut down the Myasishchev OKB, which led to the curtailment of work on a number of most important areas in the development of domestic heavy aviation.

The ZM bombers were in service with the Air Forces until the end of the 1980s, and were removed in accordance with the treaty for cutbacks in strategic offensive weapons; the ZMS2 tankers are in service today.

**KC-135A Stratotanker**

**Crew.** Four-five men.

**Dimensions.** Wingspan of 39.87 meters, area of 226.03 m<sup>2</sup>, sweep angle at 1/4 chord 35°; length of aircraft 41.5 meters, height 12.7 meters. Cargo compartment: length 25 meters, width 3.35 meters, height 2.13 meters.

**Mass.** Maximum takeoff mass 134,700 kg (KC-135A), 146,285 (KC-135P); normal landing mass 83,900 kg; maximum fuel reserve 86,050 (KC-135A), 92,210 (KC-135R); maximum fuel reserve for transfer to other aircraft 43,500 kg, 37,000 or 33,000 (depending on the series of tanker aircraft).

**Flight characteristics.** Top speed 1,000 km/hr and cruising speed of 855 km/hr at altitude of 10,670 meters with maximum fuel reserve for refueling; effective ceiling of 15,250 meters; operating radius of 3,700 km with transfer of 18,145 kg of fuel; takeoff distance 3,260 meters (2,740 for KC-135R at t = 32°C); landing runout 580 meters.

**Engines.** KC-135A—Pratt & Whitney J57-P-59W turbojet engines (4 x 6,250 kgf), KC-135R—General Electric-SNECMA CFM 56-2B-1 turbojet bypass engines (4 x 10,000 kgf); KC-135E—Pratt & Whitney JT3D-3B turbojet bypass engines (4 x 8,165 kgf).

**Equipment.** A refueling system with a telescoping boom 8.5/14.3 meters in length and a productivity of 3,400 liters/minute. The upper deck of the aircraft can be used for the shipment of cargo (it has rigging equipment and removable seating for the transport of 80 people). The KC-135F aircraft, intended for the French Air Force, is equipped with a "drogue—probe" refueling system.

The KC-135A is equipped with the AN/APN-59 navigational radar, the AN/APN-81 Doppler navigational system with an AN/ASN-7 coordinates computer, the AN/APN-69 system for finding the aircraft to be refueled and converging with it and the SRC-718 high-altitude radio altimeter.

The aircraft has no defensive armaments.

**Status.** In service with the U.S. Air Force (since 1957) and the French Air Force (12 KC-135F aircraft have been supplied for refueling the Dassault-Breguet Mirage IV bombers).

**Additional information.** The KC-135 aircraft was created according to the original design for the Boeing 707 passenger aircraft (the KC-135 has a different fuselage diameter). The first flight of the KC-135A took place in 1956. The replacement of wing covering sections was performed in 1975-88 in order to increase the service life of the aircraft (total cost of the program was 400 million dollars). Various versions of the aircraft were widely employed in the combat operations against Iraq in 1991.

Some 820 KC-135A aircraft were built in 1956-65. The retrofiting of 630 KC-135A aircraft of the U.S. Air

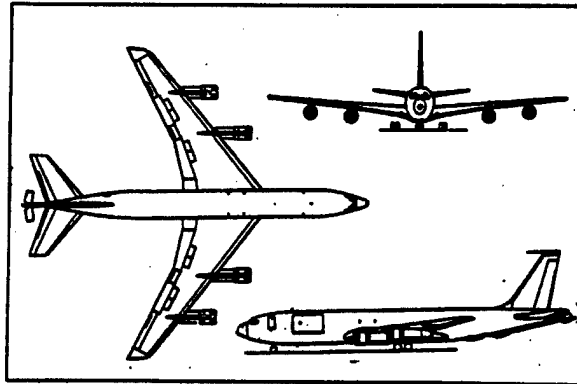

Force into the KC-135R version is planned from 1983 to 1995, through the replacement of the J57-P-59W turbojet engines with CFM-56-2B-1 turbojet bypass engines of French manufacture (the first flight of a KC-135R took place in 1982, and the aircraft are expected to remain in service until 2020). The KC-135F aircraft were upgraded in an analogous manner in 1985-88, and received the new designation KC-135FR. Some 104 KC-135A aircraft in service with the U.S. National Guard, 24 in the U.S. Air Force Reserve and 23 U.S. Air Force reconnaissance aircraft have been retrofitted with the JT3D-3B turbojet bypass engines since 1982 (the upgraded tanker aircraft has the designation KC-135E). The expenses for upgrading the KC-135A tanker into the KC-135R version totaled 20 million dollars, and into the KC-135E version 4.1 million dollars.

A large number of versions were created on the basis of the KC-135A, including the C-135 military transport, the C-135F tanker for the French Air Force, the RC-135M, RC-135W, RC-135S, RC-135U, RC-135V and RC-135X electronic surveillance aircraft and the EC-135G, EC-135H, EC-135J, EC-135K, EC-135L, EC-135U and EC-135P airborne command posts and repeater stations for communications with submerged submarines.

COPYRIGHT: "Aviatsiya i kosmonavtika", 1992.

**Articles Not Translated**

00000000 Moscow AVIATSIYA I KOSMONAVTIKA  
in Russian No 9, Sep 92 (signed to press 29 Jul 92)

[Text]

Letters From Readers .....	8-9
In a "Triangle" Configuration (L. Egenburg) .....	14-17
The "Swifts" (Lieutenant-Colonel S. Valchenko) .	18-21
Air Aces (P. Bogdanov, A. Shcherbakov) .....	26-27
The Wings of Russia (V. Tkachev) .....	28-29, 32

The Three Heights of Georgiy Beregovoy (Colonel A. Kanevskiy) .....	30
“Kudashev-1” (Colonel V. Zaretskiy) .....	30-31
Safe Landing (Who and What Supports It in the U.S. Air Force) (Colonel-General of Aviation (Retired) V. Filipov) .....	40-41
A Trip to Neptune (L. Ksanfomaliti) .....	44-45
KOSMINFORM .....	48
History of Aviation and Ballooning in Dates .....	49

COPYRIGHT: “Aviatsiya i kosmonavtika”, 1992.

**Publication Data**

93UM0241M Moscow AVIATSIYA I  
KOSMONAVTIKA in Russian No 9, Sep 92 (signed to  
press 29 Jul 92)

[Text]

English title: AVIATION AND COSMONAUTICS

Russian title: AVIATSIYA I KOSMONAVTIKA

Editor: V.V. Anuchin

Publishing house: Voenizdat

Date of publication: September 1992

Signed to press: 29 Jul 92

COPYRIGHT: “Aviatsiya i kosmonavtika”, 1992.



BULK RATE  
U.S. POSTAGE  
PAID  
PERMIT NO. 352  
MERRIFIELD, VA.

NTIS  
ATTN PROCESS 103  
5285 PORT ROYAL RD  
SPRINGFIELD VA

2

22161

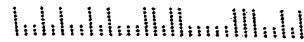

This is a U.S. Government publication. Its contents in no way represent the policies, views, or attitudes of the U.S. Government. Users of this publication may cite FBIS or JPRS provided they do so in a manner clearly identifying them as the secondary source.

Foreign Broadcast Information Service (FBIS) and Joint Publications Research Service (JPRS) publications contain political, military, economic, environmental, and sociological news, commentary, and other information, as well as scientific and technical data and reports. All information has been obtained from foreign radio and television broadcasts, news agency transmissions, newspapers, books, and periodicals. Items generally are processed from the first or best available sources. It should not be inferred that they have been disseminated only in the medium, in the language, or to the area indicated. Items from foreign language sources are translated; those from English-language sources are transcribed. Except for excluding certain diacritics, FBIS renders personal names and place-names in accordance with the romanization systems approved for U.S. Government publications by the U.S. Board of Geographic Names.

Headlines, editorial reports, and material enclosed in brackets [ ] are supplied by FBIS/JPRS. Processing indicators such as [Text] or [Excerpts] in the first line of each item indicate how the information was processed from the original. Unfamiliar names rendered phonetically are enclosed in parentheses. Words or names preceded by a question mark and enclosed in parentheses were not clear from the original source but have been supplied as appropriate to the context. Other unattributed parenthetical notes within the body of an item originate with the source. Times within items are as given by the source. Passages in boldface or italics are as published.

#### SUBSCRIPTION/PROCUREMENT INFORMATION

The FBIS DAILY REPORT contains current news and information and is published Monday through Friday in eight volumes: China, East Europe, Central Eurasia, East Asia, Near East & South Asia, Sub-Saharan Africa, Latin America, and West Europe. Supplements to the DAILY REPORTs may also be available periodically and will be distributed to regular DAILY REPORT subscribers. JPRS publications, which include approximately 50 regional, worldwide, and topical reports, generally contain less time-sensitive information and are published periodically.

Current DAILY REPORTs and JPRS publications are listed in *Government Reports Announcements* issued semimonthly by the National Technical Information Service (NTIS), 5285 Port Royal Road, Springfield, Virginia 22161 and the *Monthly Catalog of U.S. Government Publications* issued by the Superintendent of Documents, U.S. Government Printing Office, Washington, D.C. 20402.

The public may subscribe to either hardcover or microfiche versions of the DAILY REPORTs and JPRS publications through NTIS at the above address or by calling (703) 487-4630. Subscription rates will be

provided by NTIS upon request. Subscriptions are available outside the United States from NTIS or appointed foreign dealers. New subscribers should expect a 30-day delay in receipt of the first issue.

U.S. Government offices may obtain subscriptions to the DAILY REPORTs or JPRS publications (hardcover or microfiche) at no charge through their sponsoring organizations. For additional information or assistance, call FBIS, (202) 338-6735, or write to P.O. Box 2604, Washington, D.C. 20013. Department of Defense consumers are required to submit requests through appropriate command validation channels to DIA, RTS-2C, Washington, D.C. 20301. (Telephone: (202) 373-3771, Autovon: 243-3771.)

Back issues or single copies of the DAILY REPORTs and JPRS publications are not available. Both the DAILY REPORTs and the JPRS publications are on file for public reference at the Library of Congress and at many Federal Depository Libraries. Reference copies may also be seen at many public and university libraries throughout the United States.