

JPRS-UAC-93-007  
16 August 1993



**FOREIGN  
BROADCAST  
INFORMATION  
SERVICE**

# ***JPRS Report***

# **Central Eurasia**

***AVIATION & COSMONAUTICS***  
***No 1, January 1993***

**DTIC QUALITY INSPECTED 2**

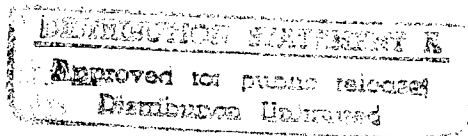

19971229 019

# Central Eurasia AVIATION AND COSMONAUTICS

No 1, January 1993

JPRS-UAC-92-007

CONTENTS

16 August 1993

[The following are translations of selected articles in the Russian-language monthly journal AVIATSIYA I KOSMONAVTIKA published in Moscow. Refer to the table of contents for a listing of any articles not translated.]

Commander-in-Chief Deynekin on State, Prospects of Air Forces [Colonel-General P.S. Deynekin; pp 2-4] .....	1
Structuring of Algorithms for Airborne Expert Systems [Colonel V. Babich; pp 5-6] .....	4
Aerodynamic Factors of Unusual MiG-31 Crash Analyzed [Colonel Ye. Vostrikov; pp 7-8] .....	7
Special Problems of Shipboard Aircraft Servicing Reviewed [Colonel V. Filipov, Lieutenant-Colonel V. Smykov; pp 9-11] .....	10
Pace of Conversion Picking Up in Air Forces [A. Lazukin; pp 11-13] .....	12
Efforts of Crack Airfield-Services Unit Lauded [Major N. Chebotarev; pp 14-15] .....	15
Baykonur Deputy Chief Recalls Early Days on Launch Pad [Major-General V. Menshikov; pp 39-41] ....	17
Procedures in Satellite Topography Described [B. Buylin and G. Fomin; pp 41-42] .....	20
Articles Not Translated .....	22
Publication Data .....	22

**Commander-in-Chief Deynekin on State,  
Prospects of Air Forces**

*93UM0518A Moscow AVIATSIYA I KOSMONAVTIKA  
in Russian No 1, Jan 93 (signed to press 10 Dec 92)  
pp 2-4*

[Interview with Russian Air Forces Commander-in-Chief Colonel-General of Aviation Petr Stepanovich Deynekin by AiK correspondent under the rubric "Topical Interview": "Time for Decisive Actions"]

[Text] The processes that are taking place today in society and the armed forces are being evaluated in equivocal fashion. One thing is undoubted—creative work is become more and more noticeable against the background of the destructive trends conditioned by the collapse of the Union and the change in power. All of this pertains entirely to the Russian Air Forces as well. How is the process of their creation proceeding? What difficulties are arising? Russian Air Forces Commander-in-Chief Colonel-General of Aviation Petr Stepanovich Deynekin answers these and other questions of our correspondent.

[AiK] Comrade Commander-in-Chief, your interview that was published in the February issue of the journal AVIATSIYA I KOSMONAVTIKA for 1991 was called "Time for Cardinal Decisions." Much has changed since that time—there was August of 1991, the Union ceased to exist in December, and the armed forces of the Russian Federation have been formed starting in May of 1992. You were named commander-in-chief of the Russian Air Forces in September of that same year. Does all of this not signify that the time has come for decisive actions in the pursuit of military reform and the organizational development of the Air Forces of Russia?

[P.S. Deynekin] Yes, that time came in May of last year, when the decision was made to form the armed forces of the Russian Federation. Other sovereign states had been able by that time to take under their jurisdiction a pretty good share of the ground, naval and air forces of the former Union. That was done according to the territorial principle and without regard for the interests of the collective security of the CIS, the extant system of troop support and command and control, the training of cadres or, most importantly, the consequences of those decisions on the officer corps and the families of servicemen.

Our attempts to preserve at least unified strategic forces in the interests of all of the republics of the CIS, including long-range and military-transport aviation, were unfortunately not successful. Russia was long hoping for good sense and wisdom from its neighbors in this difficult situation, and was thus the last to set about the creation of its own armed forces. One cannot help but recall here the saying that Russians are slow to get into the harness but travel fast. So today our efforts, and not just our thoughts, are concentrated on the fastest possible creation of the Air Forces of Russia.

[AiK] You cited data at one time that Russia had received 14,000 fliers and 5,000 aircraft in dividing up the inheritance from the USSR. Could you clarify whether Russia gained or lost out as the result of that division?

[P.S. Deynekin] Judge for yourself. The chief strategic direction for the Union was always west. And it turned out after the division that a significant portion of the latest aircraft and the well-developed infrastructure of combat aviation were left outside the borders of Russia. We got a large quantity of trainers and the corresponding airfield network. The launching of aviation formations on the basis of some of the flight schools and training centers is envisaged in order to make efficient use of that inheritance in the interests of creating a combat-capable group, economize funds and retain personnel. The Yeysk and Orenburg VVAULs [Higher Military Aviation Schools for Pilots] are thus being reformed into air divisions. Regiments flying combat aircraft are also being withdrawn from the training centers and transferred to the formations, and most importantly, without rebasing.

[AiK] Won't that "operation" have an impact on the training of personnel for the Air Forces?

[P.S. Deynekin] No, it won't. The fact is that a large surplus of flight personnel had formed even in the Air Forces of the Union over recent years. There is even less of a necessity for Russia to train pilots in the former quantity, and we thus cannot allow ourselves the luxury of maintaining so many aviation schools.

The air training regiments, at the same time, have a highly trained instructor corps and have a good physical plant. We are imparting a different quality to the air group with minimal expenditures by replacing their trainers with combat aircraft. We are thereby accomplishing a most important task for today—we are retaining the cadres and are using the airfields and the service and housing stocks in the interests of people and their combat training.

[AiK] But where are you getting the new aircraft? The Air Forces budget, after all, is so out of line with price levels that you will have to go around hat in hand, as they say.

[P.S. Deynekin] Matters have not yet come to that, thank God. We are supplementing the aircraft inventory with the aircraft being withdrawn from the Baltics, Poland, Germany and the Transcaucasus. Modern aviation hardware was concentrated there. Rejecting the outmoded MiG-23, MiG-27, Su-17 and Tu-16 aircraft, we are outfitting the regiments with new aircraft with two or more engines. I have in mind the Su-25, MiG-29, Su-27, Su-24, Tu-22M, Il-76, Il-78, Tu-95MS and Tu-160 aircraft. The Air Forces of Russia will be able to perform the tasks they face with such aircraft, despite their reduced quantities.

[AiK] Material has now been appearing in much of the mass media, the sense of which can be phrased in brief as follows: we are flying less and less, but there are more and more accidents and crashes; if that goes on in the future as well, won't Russia become wingless with time?

[P.S. Deynekin] I will answer unequivocally that no, it won't. Russia was, is and will be a great air power regardless of any difficulties and deprivations. Yes, we are flying less today, but that is a temporary phenomenon. It is explained by a lack of the means (aviation fuel, oils, spare parts, engines) and the necessity of creating the system of logistical support for combat training all over again.

Now about flight safety. Analysis of the statistics on flight accidents over the last 25 years shows that despite the very difficult situation, the past year was not one of the worst for the Air Forces. But I cannot forgive myself or those who were directly or indirectly to blame for three tragedies—the collision of two ZMS2 aerial tankers, the death of people in the takeoff of an AN-12 aircraft at Nakhichevan and the crash of an An-22 in Tver. All of those accidents occurred through the fault of first-class pilots, in good weather and using aircraft that were in good working order, and they were due only to violations of flight regulations. And it was not a matter of a lack of kerosene, housing and decreased flying time, but the willful treatment of the essence of democratization by some personnel, which led to a decline in the level of military, flying and technological discipline in aviation. That situation cannot be tolerated, and references to difficulties are not appropriate here. We will be very exacting toward ourselves and all who do not wish to understand that an aircraft is not subject to any authority, except of those who respect the rules of flight.

[AiK] There are quite a few rumors spreading now about a "mighty outflow" of pilots from the Air Forces of Russia, literally the flight of the officer corps. How would you comment on this information?

[P.S. Deynekin] I should say that this is not so. We are already accustomed to the fact that some of the mass media, unfortunately, do not put themselves out to check out rumors and misinform the readers.

Yes, we have been disbanding even large air formations, with the basic goal of reaching the size allotted for the Air Forces and cutting back on the administrative apparatus. No cases of the flight of officers, the more so pilots, from the Russian Air Forces have been established. But the fact that many have flown over to us, even with their regimental colors, is evidently known to many. Some 1,600 officers, of whom 400 were pilots, moved here from Ukraine alone last year at their own request, parting with many amenities. We are not restraining those who do not express a desire to continue service in the Russian Air Forces.

At the same time, we still do not have enough aviation specialists. But that is not the result of their "flight," but rather a consequence of the miscalculations of those

supervisors who are responsible for the training of cadres. We intend to rectify the situation in the near future, by increasing salaries for IAS [aviation engineering service] specialists, raising military ranks by one step and improving their living and working conditions. We want to attract civilian specialists for technical positions. All of this, one would think, will raise the prestige of the technical and engineering professions. The minister of defense supports us in the resolution of those issues.

[AiK] So then reform is proceeding in the Air Forces. It is taking place under difficult conditions and is reflected in the fates of tens of thousands of people. Doesn't it seem to you that those who are experiencing the reforms in Russia, in permanent base locations, have turned out to be in a more advantageous position and have more social protections than those who are forced to evacuate the regions of international conflicts and return home from Germany, Poland and the Baltics?

[P.S. Deynekin] All servicemen in the Air Forces formally have the same social protections. There is in fact a large difference in the degree of domestic deprivations that fall to the lot of the fliers. It is naturally easier to bear the difficulties of service under one's own roof. The evacuation of regions of international conflicts and withdrawal from other states, however, has different effects on officers and warrant officers.

Officers who have returned to Russia from Poland or Germany and have been receiving their pay in hard currency for several years feel more confident on a material plane. As for those who left the Transcaucasus, Moldova and the Baltics literally under the gun, they, like refugees, are experiencing great difficulties, associated first and foremost with the loss of housing and property. The Air Forces do not have the funds to render them substantial material support. But we remember them, value their endurance and patience, and are trying to help as best we can. The minister of defense issued a directive at our suggestion, according to which officers who have served in the ZGV [Western Group of Forces] for more than three years are being replaced first by those who suffered in the unexpected withdrawal of units. That does not compensate them for the moral loss, but we hope to make good the material loss.

[AiK] Ethnic conflicts have broken out in a number of regions of the former USSR. Assertions have even appeared that Russian mercenary pilots have been taking part in combat operations. Does that correspond to reality?

[P.S. Deynekin] No, it does not. Only pilots of the local nationalities are taking part in combat operations at the "hot spots." We know them by name. I feel that since it is first and foremost the civilian population that suffers from the use of combat aircraft in a civil war, the warring pilots—regardless of national affiliations—are criminals, and should be brought to criminal liability.

We do not engage in deliveries of aviation hardware to regions of ethnic conflicts. The aircraft that are being used in combat operations are either produced in the sovereign states themselves or are procured from "third countries." Our pilots make flights only in the interests of ensuring the national security of Russia, delivering and taking out contingents of peacekeeping forces, evacuating refugees and supplying foods and medicines to the "hot spots." Unfortunately only one episode of the heroic everyday life of aviators is well known, connected with the evacuation of the embassy of Russia from Kabul, when the airborne assault forces and pilots returned their compatriots safely to the Motherland while under fire and losing one aircraft.

We brought the families of servicemen in the Transcaucasus out in good time, before the unleashing of broad-scale armed conflicts in that dangerous region, and then we redeployed the whole inventory of combat aircraft out of there to Russia literally just a few days before the worsening of relations between Armenia and Azerbaijan and before the tragic events in Abkhazia. Had that not been done in time, the situation would have worsened even more, since the opposing sides unambiguously declared their desire to have combat aircraft at their disposal.

[AiK] You have visited several foreign countries recently. What did those trips give the commander-in-chief of the Air Forces, to whom it has fallen not only to command but also to reform the Air Forces?

[P.S. Deynekin] I flew strategic and long-range bombers for a long time and was "abroad" from the Union often, only in the air rather than on the ground. And only after becoming the commander-in-chief of the Air Forces have I been in several countries in an official capacity. Those trips were not unproductive. Much of what I got to see and learn, I feel, would be expedient and possible to adopt into the combat training and everyday activity of the Air Forces of Russia even today. The training of flight cadres, for example. With the opportunity to select young people who have expressed the desire to become pilots and are suited for flight work in their psycho-physiological traits, we will train them theoretically for three and a half years, and then practical skills for a year and a half—up to two hundred hours of flying time. It would be correct, in my opinion, to train everyone under a program at the schools, and then at graduation decide who will fly on fighters and who in assault aircraft, reconnaissance aircraft or bombers. The foundation of theoretical and aerial proficiency will be the same for all, and the graduates of the schools will complete specialties with a regard for Russian specifics.

This system assumes a five-year term of study. The cadets experience unbelievable demands in a four-year cycle. Their program is one and a half times more intensive than for students at any technical institution of higher learning. And our graduates endure it only because excellent health is a most important condition of selection. I want to emphasize that the adoption of the

new system is envisaged over several years, starting in 1993. We will thereby avert an avalanche of dismissals of trained instructor personnel.

[AiK] Is it true that only the RVSN [Strategic Rocket Forces] and the construction troops are subject to manpower acquisition by conscript personnel first and foremost? What about the Air Forces?

[P.S. Deynekin] There are still officers in the Ministry of Defense of Russia who feel that the priority branches of the service are the RVSN and the Navy. But Minister of Defense General of the Army P. Grachev has indicated that the Air Forces, PVO [Air Defense Troops] and other mobile forces cannot be outcasts in the consideration of questions of manpower acquisition and logistical support. As for the conscription of youth to complete conscript service, that is a common problem for all of the branches of the armed forces. Everyone does not have enough soldiers. Understanding the difficulty of the situation, we have developed a proposal to replace about 20,000 positions of NCOs and soldiers with manual or office personnel. Some 22,000 positions in the Air Forces can even now be replaced with servicewomen. That has been 97-percent realized in long-range aviation, for example. It is only a third in other formations, where the corresponding work is being poorly conducted. There are quite a few positions in the Air Forces, after all, in which women are entirely able to serve (in laboratories, at communications centers, in headquarters, at mess halls and hospitals). I would like to take advantage of the opportunity to invite the female readers of the journal to serve in the Air Forces.

[AiK] Judging by the activity, you are an incurable optimist. At the same time, our reality is not suited to that; rather the contrary. Isn't your disposition changing in this regard?

[P.S. Deynekin] Yes, I have been and am an optimist by nature. Because I believe in people and Russia. A Fatherland such as ours cannot be driven to its knees. Our people are so spiritually strong, and the country is so rich, that I am sure that the resurrection of Russia is an irreversible process. And it is not the diameter of the pipeline pumping oil and gas abroad that will determine the image of the state, but rather the aerospace industry, which is one of the most important sources of the progress, well-being and independence of the people.

[AiK] Comrade Commander-in-Chief, the Air Forces journal AVIATSIYA I KOSMONAVTIKA is 75 years old in 1993. What would you wish its editorial collective and all the readers?

[P.S. Deynekin] Future creative successes to the editorial collective, and clear skies and happiness to all the readers.

COPYRIGHT: "Aviatsiya i kosmonavtika", 1993.

### Structuring of Algorithms for Airborne Expert Systems

93UM0518B Moscow AVIATSIYA I KOSMONAVTIKA  
in Russian No 1, Jan 93 (signed to press 10 Dec 92)  
pp 5-6

[Article by Candidate of Military Sciences Colonel (Reserve) V. Babich under the rubric "Combat Training: Experience, Problems, Opinions": "Artificial Intelligence at the Service of the Pilot"; continued—for beginning see Nos. 10—12 for 1992]

[Text] The first prototypes of fast-acting, on-board expert systems—the pilots' consultants—have already been tested for "intellectual compatibility" with man on actual flights. The tests have shown that one can expect the maximum return from an electronic machine only provided a number of requirements are observed.

The computer, for example, in the opinion of the flight personnel, should provide the pilot first of all with the information being received from the on-board radar, not be of an informative nature and not be intended for prolonged consideration, but rather for immediate control; second, provide timely "prompts" in cases where delay in decision-making for entering battle, prolonging it and the like is extremely dangerous; and, third, depict on the indicator the tactical situation in the form of symbols that correspond not to an enemy "frozen" at a given moment, but where possible his future actions as well. Specialists express the hope that a real chance to eliminate the contradiction between the rapid pace of battle and the process of human thinking, which lags considerably behind it, will soon appear with the fulfillment of these conditions.

An expert system in turn has the requirement, first of all, for the constant "feed-in" of ordered information possessed by the pilot; second, the receipt from him of a "set" of standard variations for the disposition of forces, tactical devices and combat maneuvers, as well as the traits of the situation determining their performance; and, third, the presentation by the pilot of an algorithm for the performance of tactical tasks, making it possible to develop or correct the plan for the combat flight (battle).

An expert system, as has already been noted, is able to "think" only in a standard fashion, and "knowledge" (in the first requirement) is thus understood to mean a complete "library" of scenarios for the actions of the pilot in those situations he has successfully resolved in the past in flight on one certain type of aircraft. Recall that the expert only assesses the decision made by the pilot and provides its conclusion, but does not create or invent anything new. It produces such a scenario quite quickly, however, through a comparison of the current situation with a standard one in which the most effective are selected from a host of actions undertaken earlier.

The fact that the constituent elements of any controlling system should "think" in the same categories is well

known. A question naturally arises in this regard—is the pilot's thought process in the performance of a combat flight given to any kind of classification? Western psychological specialists give a positive answer to that question.

The pilot, in their opinion, resorts to **empirical thinking** (according to ready models) in the simplest of situations, when he has a prepared decision that has already been sufficiently well proven in practice. In that case he equates the situation taking shape in the course of a combat flight with one of the "models" stored in his memory, and devises a stereotypical "reciprocal reaction" to it. One may cite as an example such stages of the flight as the assembly of the group after takeoff, the restructuring of the battle formation or the break-up of the group for landing approach. Simple situations are easily programmed. Suffice it to recall the scheme for the performance of a flight to intercept an airborne target under which the crews of first-generation supersonic fighters operated: they were vectored in according to "commands" from an automated ground system.

**Axiomatic thinking** (according to rules) relies on a list of simple instructions that are elevated to the rank of truths, and thus do not require substantial proof. Our fighter pilots, for example, relying on their own experience, formulated concise "instructions" for waging group aerial battle as early as during the Great Patriotic War that, I think, would not be superfluous to recall even today.

When searching for an aerial enemy, "allocate scan sectors among the pilots in the group," "try to find the enemy at long range so as to be the first to attack," "search continuously," "do not travel in tight battle formation, which is easily noticeable from a distance" and "open up along the front, don't make sharp turns." And the following list of rules: "try to remain undetected when converging with an enemy," "keep an advantage in altitude," "use natural camouflage against the background of the sun, ground or clouds," "reduce intervals rapidly after the execution of a maneuver" and "end convergence with concentrated fire." And, finally, rules of attack: "take care to cover the 'tail,'" "eliminate yaw and slip when training weapons," "aim from the 'dead zone' of the enemy's scan zone," "fire in short bursts..."

Such rules for waging close aerial combat have unfortunately virtually disappeared from the Field Manual today (judging from everything, its compilers seem to feel that the modern pilot would not have to think quickly at all).

**Dialectical thinking**, in turn, is connected with manifesting the creativity of the individual. The pilot, as a rule, investigates an unfamiliar situation quite quickly and finds the correct solution, resorting to thought experiment under conditions of uncertainty and then incarnating what he came up with into practice. Actions by the pilot according to "ironclad" rules and ready "models" are ruled out in that case.

Priority has always been given to axiomatics in the development of tactics for group aerial battle. And that is no accident, since rules as guides for action have always possessed one substantial advantage—a pilot, in acting according to them, saves decision-making time thereby and protects himself to a certain extent against gross errors in battle. The Manual of Combat Operations for Fighter Aviation (NIA-45), issued hot on the heels of the war, even said that “All organization of the operations of fighters and preparation and waging of battle should proceed from the most important principle of saving time. Everything must be done more quickly than it is done by the enemy.”

To this should be added that the rules for the stage-by-stage waging of aerial warfare were harmoniously intertwined in the formula “altitude—speed—maneuver—fire.” The pilot was to stock up on altitude and then, having gained altitude while converging, executed a maneuver to get to the rear hemisphere of the enemy and open fire from close range. The principle of saving time forced one to do all of this sooner than the enemy. But quick thinking by the pilot was required for that to happen. And in that he was helped, aside from the indicated rules, by the use of standard tactics and combat maneuvers, whose timely execution made it possible to react correctly to a change in the aerial situation.

A perhaps somewhat unexpected conclusion suggests itself from all of the aforementioned: it may be stated with a certain confidence that the fighter pilots of half a century ago—the participants in aerial battles at the fronts of World War II—were ready to enter into a “dialogue” with an on-board expert system, had they had them on their aircraft, since they possessed a sufficient set of assimilated standard combat situations with the rules for their resolution. The level of development of tactical thinking at that time moreover fully satisfied the “demands” made by an on-board computer toward the pilot.

We will return, however, to the realities of the present day and continue the discussion of whether the modern pilot is able to “train” the expert system and make it his own consultant in both short- and long-range battle. The system of labor does not need to be “tuned” in the first case, since all of the “secrets” of close-range battle have already long been revealed. The same thing is quite difficult to do in the second instance, however, since aviation theoreticians have still not had the last word on this score owing to the lack of the necessary practice in long-range confrontations to study.

The actions of close-range battle, which would have receded with the advent of third-generation guided missiles, proved their worth anew after the war in the

Persian Gulf, which was largely facilitated by the involvement of two squadrons of F-117A Stealth aircraft in the Desert Storm air operation. Those aircraft, by the way, had neither radar nor medium-range air-to-air missiles on board. It is thus difficult to suppose in what key a confrontation would have taken place, had it happened, between Iraqi fighters and the American “invisibles.” It would most likely have had the outlines of classic close-range combat. Indeed, how could it have been otherwise when the poor radar contrast of the F-117A forced the enemy to conduct only a visual search? There could be no discussion of any attacks by Iraqi interceptors on reciprocal headings, they would have been impossible to accomplish in practice; reliable vectoring of the fighters from a command post was also ruled out...

It is noteworthy that the training program for American fighter pilots has the mastery of close-range aerial battle in first place, and only then long-range battle. It is felt that an on-board expert system should also begin “self-training” with close-range battle. As has already been noted, for that it requires the proper algorithm, developed on the basis of modeling a battle in the following sequence: dividing the process of an encounter into separate stages (blocks), described separately; establishing the input and output data for each block; and, combining several blocks into a unified whole while ascertaining the logical ties among them (see figure).

According to the accepted rules for constructing algorithms, to describe a block in the initial stage means to define its basic contents first and foremost, and only then the task performed by the pilot and the possible variations for performing it. The output data from each block can in this case hypothetically be called an intermediate solution.

The content of the “search” block, for example, includes the detection and identification of the target. The principal task of the pilot is to distinguish reliably, that is to establish, the type of target detected and determine the nature of its intentions. And only after that, at the exit from the block and on the basis of an assessment of the situation, is the solution formed for the waging of attack or defensive battle.

The block diagram shows, so to speak, the structure of close-range battle, its “skeleton.” Each block must necessarily be “saturated” with standard devices, variations for the structuring of forces and maneuvers that vary in nature for a complete description of the process of an aerial encounter, achieved by reducing its structures and tactics to a unified whole. Another column of blocks—“Means of Accomplishing Tasks”—will then appear without fail. That will then be an algorithm for a higher “intellectual” level than the existing one.

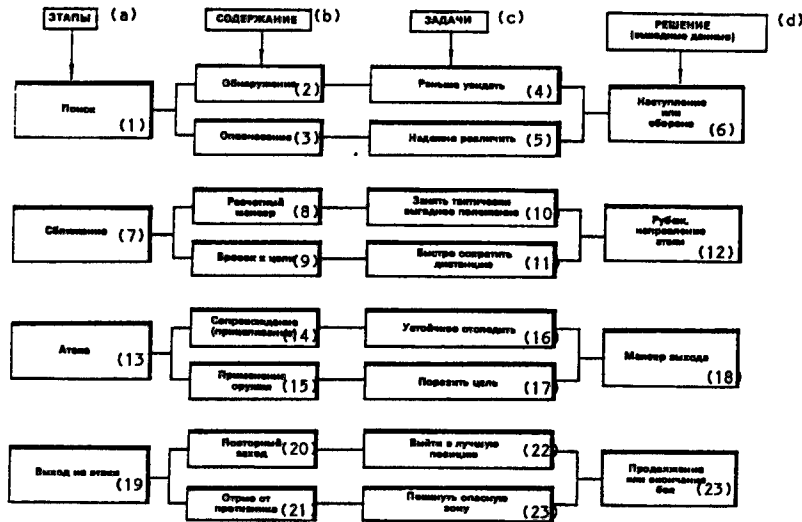

Block diagram of close-range aerial battle

## Key:

A. Stages

B. Content

C. Tasks

D. Solution (output data)

1. search

2. detection

3. identification

4. see sooner

5. reliably distinguish

6. attack or defense

7. convergence

8. nominal maneuver

9. close to target

10. take up tactically advantageous position

11. reduce range rapidly

12. line and direction of attack

13. attack

14. tracking (aiming)

15. use weaponry

16. track steadily

17. defeat target

18. disengagement maneuver

19. break-off of attack

20. repeat approach

21. disengage from enemy

22. get to better position

23. leave dangerous zone

24. continue or end battle

It is thus not difficult to note that the development of such tactical algorithms is the lot of professionals—the pilot and the weapons officer/programmer. That tandem, however, should be replaced by on-board expert

systems in the future (and to all appearances, the not-too-distant future). (*Conclusion to follow*)

COPYRIGHT: "Aviatsiya i kosmonavtika", 1993.



### **Aerodynamic Factors of Unusual MiG-31 Crash Analyzed**

*93UM0518C Moscow AVIATSIYA I KOSMONAVTIKA in Russian No 1, Jan 93 (signed to press 10 Dec 92) pp 7-8*

[Article by Candidate of Technical Sciences Colonel Ye. Vostrikov under the rubric "Flight Safety: A Special Case": "Could the Takeoff Have Been Successful?"]

[Text] The supersonic MiG-21 taxied out to the start position. The engines, aircraft systems and on-board equipment were operating normally, according to instrument readings. The crew requested permission for takeoff.

The flight operations officers did not notice anything special in the takeoff run—the afterburners of both engines turned on simultaneously, the time for the run was within the standard values, and separation from the runway occurred without exceeding the allowable value for the angle of attack. A small right bank arose after separation, however, and after six seconds began increasing rapidly with the angular velocity increasing as well to 70°/sec. The crew was forced to eject...

It became clear from the explanations of the crew that the left pedal had been set at the 1/3 stop in the takeoff run to keep the aircraft on the runway axis; after separation right banking occurred that was offset by setting the aircraft control stick to the left stop, after which the aircraft began to come around to the right. The readings of instruments monitoring the operation of vitally important aircraft systems confirmed their operability. The signal systems provided no information on the failure of the aircraft hardware.

The specialists faced a task—to determine the cause of the flight accident. An analysis of the recordings of the flight data recording equipment [SOK] made it possible to depict the dynamic of the development of the emergency situation for the MiG-31, and to define the specific directions for researching the operability of aircraft systems.

It was ascertained in particular that the longitudinal load factor was 0.41 in the takeoff run, while on prior flights with analogous weather conditions, takeoff mass and engine operating modes  $n_x = 0.56-0.57$ . It became obvious that actual engine thrust was approximately 5,000 kgf less than nominal. The recordings of the SOK confirmed the readings of the crew, according to which the pilot had to hold the pedal continuously and the rudder accordingly, offsetting the turning, to hold the aircraft on the runway axis during the takeoff run. The conclusion was drawn, based on those two factors, that a drop in thrust in the right engine had occurred. It was established from the parts and assemblies that were preserved that while the left engine was operating in the "full afterburner" mode, the right was at "minimum afterburner." Both engine controls, meanwhile, were in the "full afterburner" position.

The group of expert specialists thus determined the failure quickly. But a question arose: could the pilot have recognized this during the takeoff? It would have been very difficult to do, in the opinion of most of the experts. The signals, first of all, were indicating that the engines were operating in afterburner mode and, second, it is difficult for a pilot to monitor, the more so to compare the readings of, all the instruments and uncover discrepancies even if they were manifested. The recordings of the SOK confirmed the conclusion that the pilot had understood from the nature of the aircraft control that the aircraft was for some reason straining to come around to the right, and set the pedal to balance it. But that did not put him on guard; coming around, after all, can be caused not only by a partial engine failure, but also is also observed, for example, with aerodynamic asymmetry of the aircraft, a strong crosswind or the effects of some other factors.

The actions of the pilot during the takeoff were logical, and the partial failure of one engine during takeoff should not have led to a flight accident; the aircraft gained the necessary speed for separation, and it continued to increase while the angle of attack did not exceed the allowable value.

So what was the cause of the accident? The nature of the changes in the flight parameters and the controlling actions of the pilot, according to the SOK recordings, give grounds to suppose that he was not able to determine the cause of the yaw and make the correct decision to control the aircraft after its separation in the absence of instrument information on the partial failure of one engine. Some of the specific features of the stability and controllability of the aircraft that were displayed on this flight are also not reflected in the crew instructions and, possibly, were not known to them.

We will consider the dynamic of the development of the emergency situation in more detail starting with the time of aircraft separation from the runway ( $A_1$ , Fig. 1) to the ejection of the crew ( $A_2$ ), and will try to tie the recorded nature of the changes in the parameters during this time interval with the specific features of the stability and controllability of a modern, supersonic and highly maneuverable aircraft.

The recordings show that after the separation of the MiG-31 from the runway, the rudder was moved to a position close to neutral ( $B_1$ ), while the uncompensated moment from the difference in engine thrust caused a lateral load factor ( $n_z = 0.03$ ). The aircraft began to slip on the left wing, leading to banking to the right. The lateral load factor increased with the gain in altitude. The pilot set the ailerons to offset the banking, and six seconds after separation had set them all the way. The lateral load factor increased to 0.17. The aircraft subsequently began to come around to the right with increasing angular velocity. The crew ejected.

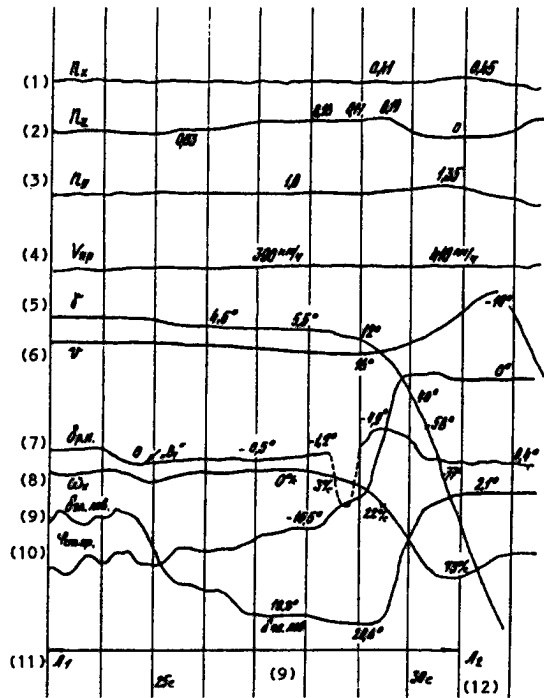

Fig. 1.

Key:

- |          |                      |                         |                       |
|----------|----------------------|-------------------------|-----------------------|
| 1. $n_x$ | 4. $V_{max}$ , km/hr | 7. $\delta_{rud}$       | 10. $\psi_{rt\ stab}$ |
| 2. $n_z$ | 5. $\delta$          | 8. $\omega_x$           | 11. $L_1$             |
| 3. $n_y$ | 6. $\nu$             | 9. $\delta_{left\ ail}$ | 12. $L_2$             |

It can be seen from this brief analysis that conditions arise in the operating realm of flight modes when slippage is present where the transverse controls prove to be insufficient to balance aircraft roll. This is explained by the specific features of changes in the stability and controllability characteristics of the aircraft in takeoff. It is known that transverse and directional stability are described by the factors  $m_x^\beta$  and  $m_y^\beta$ , and controllability

by  $m_x^{\delta_{ail}}$  and  $m_y^{\delta_{rud}}$  (where  $\beta$  is the angle of slip, and  $\delta_{ail}$  and  $\delta_{rud}$  are the angles of inclination of the ailerons and rudder). The dependence of those two factors on the angle of attack is shown in Fig. 2. The aircraft has large values for  $m_x^\beta$  in takeoff and landing, and small values for  $m_x^{\delta_{ail}}$ . This circumstance makes the aircraft "react" energetically to slip by rolling at large angles of attack, and it is necessary to set the ailerons to offset it.



Рис. 2

Fig. 2.

- Key:
1.  $m_x^\beta$
  2.  $m_y^\beta$
  3.  $m_x^{\delta_{ail}}$
  4.  $m_y^{\delta_{rud}}$
  5.  $\alpha$

The first feature, then, is increased transverse stability. Recall that the aircraft is statically stable in a transverse regard if an aerodynamic roll arises in slippage that acts in a direction opposite to the slip. Flight practice shows that excessive transverse stability is just as undesirable as instability. The "reaction" of the aircraft to the slip that arises in the former instance becomes a very sharp one, and it easily answers with banking to small changes in the angle of slip that arise in flight; in the latter case, a "reciprocal reaction" of banking appears to the setting of the rudder. It can be seen from the SOK recordings that the pilot remembered the effects of the angle of attack on the stability and controllability characteristics, since he vigorously pushed the stick away from himself to the extent of the increasing speed after the separation of the aircraft from the runway, without exceeding the allowable values for the angle of attack.

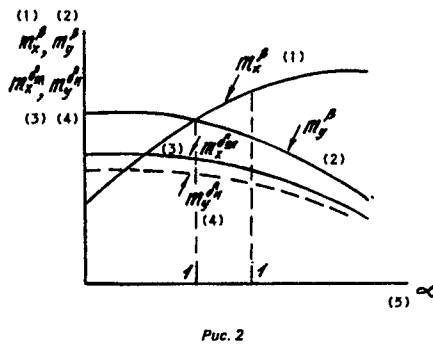
The second specific feature that was manifested on this flight was that after the separation of the MiG-31 from the runway, the lateral load factor increased to the extent the pilot set the ailerons to the maximum values—that is, so-called parasitic slippage arose. What is the cause of that?

We turn to Fig. 3, in which are shown the forces that were acting on the aircraft in the manipulation of the ailerons. Additional positive normal force  $\Delta Y_{ail}$  appears on the wing with the lowered aileron in flight, with

roughly the same value of the force in the opposite direction on the wing with the raised aileron. They create the roll controlling moment  $M_{x_{ail}}$ . Yaw arises simultaneously, directed toward the wing with the lowered aileron, as a consequence of changes in the tangential components of the full aerodynamic force of the wings  $X_{ail}$ . The yaw moment created by the ailerons is small at small angles of attack and lengthening of the wings, but when they are increased it begins to "manifest itself" and create an increase in lateral load factors.

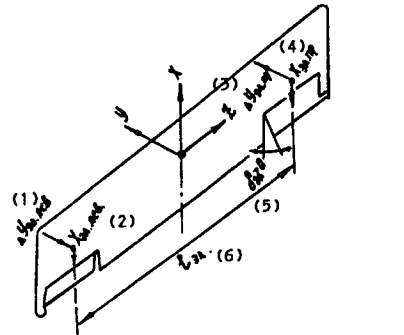

Fig. 3.

- Key:
1.  $\Delta Y_{left\ ail}$
  2.  $X_{left\ ail}$
  3.  $\Delta Y_{rt\ ail}$
  4.  $X_{rt\ ail}$
  5.  $\Delta_{ail}^0$
  6.  $z_{ail}$

In this case the deflection of the ailerons (the right—down) conditioned an additional increase in the angle of slip on the left wing. This led to rolling to the right, to offset which it was necessary to increase the angle of deflection of the ailerons, which in turn caused an additional increase in the angle of slip etc. This process took place with a neutral rudder setting over 5—6 seconds, to the maximum angles for setting the ailerons ( $20^\circ$ ). The uncompensated rolling moment from the slip then began to bring the aircraft around to the right, and it was now impossible to offset it.

A third specific feature of this flight was the fact that a decline in the increase in the controlling moment of the roll occurred to the extent of the deflection of the ailerons; that is, a flattening out of the function  $m_x = f(\delta_{ail})$  took place at large angles of deflection of the ailerons.

All of these factors in the aggregate led to the fact that with the rudder in a position close to neutral, the aircraft effectively lost transverse controllability. The automatic control system could have been of help in this situation, but it had been turned off since there exists a temporary restriction against turning it on.

It thus becomes obvious in an analysis of the recordings of the SOK that the slip had to be removed using the rudder and, only in a case where it was not entirely eliminated, by the action of the ailerons.

But a sensible question arises—what standard documents indicate that one cannot fly with slip in this configuration and at what angles of slip is the maximum deflection of the ailerons insufficient to balance the aircraft in roll? The instructions are unfortunately silent on this matter. This flight accident testifies convincingly how important it is to set forth in the crew instructions the physical essence of specific features of the stability and controllability of the aircraft and the sequence of actions of the pilot. I would like to note in conclusion that an additional increase in lateral load factors (angles of slip) with deflections of the ailerons is also observed on some other types of highly maneuverable aircraft, especially at large angles of attack, and that must be remembered.

COPYRIGHT: "Aviatsiya i kosmonavtika", 1993.

### Special Problems of Shipboard Aircraft Servicing Reviewed

93UM0518D Moscow AVIATSIYA I KOSMONAVTIKA in Russian No 1, Jan 93 (signed to press 10 Dec 92) pp 9-11

[Article by Colonel V. Filipov and Candidate of Technical Sciences Lieutenant-Colonel V. Smykov under the rubric "In Naval Aviation": "IAS Aboard Ship"]

[Text] *A military story relates an episode where the commander of an infantry subunit being evacuated from an encirclement on a ship flew into a rage when seeing the luxurious appointments of the commander's quarters right after the foxholes. But his anger was turned into immeasurable respect toward the sailors when an air raid started—one could at least burrow into the ground in a foxhole...*

*We think that the specialists of the Air Forces IAS [Aviation Engineering Service] who become familiar with this article, dedicated to the basic features and problems of the technical operation of carrier-based aircraft, will be filled with respect for their colleagues on aircraft-carrying ships (ANK), overcoming their own, particular difficulties along with those common to all aviation personnel.*

Ships of the Russian naval forces began to be used as a sea-going base for aircraft starting in February 1915. The first aircraft carrier was the ship Orlitsa, refitted from the steamship Emperor Aleksandr. That ANK was only used, however, to transport, redeploy and prepare seaplanes for flight; they took off and landed on the surface of the water. The history of shipboard aviation should thus be traced to the times of the creation of an aircraft able to operate (take off and land) from a deck.

The first domestic aircraft of this type were helicopters. The OKB [Experimental Design Bureau] under the supervision of N. Kamov was involved in their development. A vertical takeoff and landing (SVVP) aircraft was created by the OKB headed by A. Yakovlev.

A specially designed and built aircraft-carrying ship—the Moskva ASW cruiser—was launched in 1967. It was armed with a squadron of Ka-25 ASW helicopters. A special standard subunit—combat unit six (BCh-6)—was provided to support the flights and service them. A second ASW carrier, the Leningrad, joined the Navy in 1969.

The appearance of the cruisers Kiev, Minsk, Novorossiysk and Fleet Admiral of the Soviet Union Gorshkov in the 1970s and 1980s was a further development in the class of aircraft carriers with group basing of shipborne aircraft (LAK). They are equipped with helicopters and Yak-38 SVVP aircraft.

Yard, cruise and state testing of a fundamentally new heavy aircraft-carrying cruiser (TAKR), the Fleet Admiral of the Soviet Union Kuznetsov, took place in 1990-91; it was markedly different from the ANKs built before it in dimensions, ship's design and the types of aircraft based on it. The OKBs imeni P.O. Sukhoy and A.I. Mikoyan developed aircraft able to take off and land using special ship designs and aircraft systems. Helicopters were also based on the TAKRs, for which takeoff and landing pads were provided.

The takeoff is executed from restraining devices using exhaust-gas deflection panels at the launch positions with a ramp (with an angle of inclination of 14°), taking advantage of the high thrust-to-weight ratio of the aircraft. We would note that it is accomplished using steam catapults in the navies of other countries, which are able to propel the aircraft to the necessary liftoff speed. Landing is made using arresting gear with braking machinery, which dampens the kinetic energy of the aircraft when its tail hook snares one of four cables.

Specially created complexes are used for the technical maintenance (TO) of the LAK on board the TAKRs. The shipboard servicing equipment includes permanent (placed in the ship with a regard for the maximum

standardization of for all LAK) and temporary (formulated for each type of aviation hardware and supplied to the ship together with the LAK of the operating organizations) sets of gear. The automated monitoring gear (KSAK) includes both portable installations for seeking out faulty equipment on board the aircraft at engineering stations on the flight deck, and fixed positions in the hangars. The helicopter TO uses stands, test and measurement apparatus and general-purpose instruments, which are structurally part of the KSAK and are installed at facilities for routine servicing.

Technical servicing of the aircraft includes the performance of operational servicing, repair, overhaul, fine-tuning and adjustment work, as well as routine maintenance for helicopters. The operational servicing is accomplished both at engineering positions on the flight deck and in the hangar, but the refueling, refilling of oxygen and reloading of ordnance (ASP) are performed only on the flight deck. Routine servicing, repair and overhaul work are performed at repair positions located in the hangars.

Small tractors are used to move the aircraft around the deck, and belt transporters and turntables in the hangar. The aircraft are raised to the deck using aircraft elevators on the starboard side in the bow and stern of the ships. The ASP is stored in magazines intended for that purpose; it is brought to the flight deck using special elevators.

The experience accumulated on the ANKs built earlier, as well as the performance of cruise and state testing of the Fleet Admiral of the Soviet Union Kuznetsov TAKR, makes it possible to ascertain the specific features of the operations of aircraft in ships. We will list only the principal ones:

- restricted space, naturally requiring the corresponding design of the LAK. It conditions the requirement for the constant performance of operations for the folding and unfolding of wing panels, stabilizers and main rotor blades, both in storage and in preparations on the flight deck or in the hangar;
- the necessity of planning the positioning of the LAK in the hangar and on the flight deck with a regard for carrying out preparations for flight, bringing them up to the flight deck and making takeoffs and landings. This is caused by differences in the equipping of the engineering positions with individual refueling and weapons hanging gear, as well as the restrictions placed on them for starting aircraft engines and taxiing LAK to their launch positions;
- the necessity of the mandatory tie-down of the aircraft and servicing equipment, especially under stormy conditions, when raising and lowering the aircraft and ordnance on lifters and elevators, along with the strict observance of fire-safety measures; and
- the requirement for anti-corrosion protection of the LAK and the performance of the corresponding preventive measures using special installations and positions for washing down the LAK.

The variety of aviation hardware on board the Fleet Admiral of the Soviet Union Kuznetsov TAKR, under the conditions of prolonged sea cruises, complicates the task of determining the optimal complement of spare parts and materials for the whole period allowing for the requirements of LAK reliability, and it varies substantially depending on the climate zones (the starting reliability of gas-turbine engines, for example, drops sharply in the tropics). The constant separation of the aircraft-carrying ships from their base also conditions increased requirements toward the effectiveness of field repairs of the LAK. An efficient strategy for it has yet to be determined.

Problems also exist in the servicing of LAK equipment and armaments, on the solution of which the duration of their preparations, reliability and flight safety all depend. The entry of flight information into the LAK on-board equipment from shipboard systems, the alignment of the inertial-navigation systems and their adjustment before a flight all have to be accomplished with a regard for tying in with the ship's coordinates and maneuvers it is making. The automated entry of flight information is not entirely accomplished, leading to a sharp increase in labor expenditures for the preparation of LAK for flight. The prolonged running of on-board electronic equipment requires forced cooling from ship's air-conditioning systems, and since the number of such positions is limited on a TAKR, it is still one of the largest bottlenecks in organizing the preparation of the LAK for flight. Special techniques to form up the required set of ordnance, allowing for the time to bring it up and places to store it, must be developed due to the low productivity of the ASP feed lines. A technique for adjustment and registration operations has not yet been devised. The efficiency of small-scale mechanization gear remains low, as a consequence of which individual types of ordnance are mounted only manually.

There are also difficulties connected with the habitability of the ANKs. The question of protecting the servicing personnel against high-power electromagnetic fields when working with ship's electronic gear is a particularly acute one. Protection of engineering and technical personnel supporting the LAK flights against the powerful noise and vibration burdens is no less important. Representatives of the IAS are experiencing an acute need for special protective gear.

There is, finally, one more item that should be mentioned in particular, since it has a direct effect on the quality of aircraft preparation for flights and, accordingly, their safety. That is the level of staffing and training of personnel in the first battalion of BCh-6, intended for the performance of routine maintenance and complex repair and overhaul work on LAK. The lack of continuity in the complement of aircraft on an ANK and the great variety of types could lead to the fact that IAS specialists will be unable to know thoroughly all of the types of aircraft based on a ship. They will moreover inevitably come to lose certain practical skills over time as well. The task of the efficient utilization of these specialists thus needs to be resolved right away.

COPYRIGHT: "Aviatsiya i kosmonavtika", 1993.

### Pace of Conversion Picking Up in Air Forces

93UM0518E Moscow AVIATSIYA I KOSMONAVTIKA  
in Russian No 1, Jan 93 (signed to press 10 Dec 92)  
pp 11-13

[Article by Candidate of Historical Sciences A. Lazukin under the rubric "Topical Theme": "Conversion—An Ordinary Matter?"; conclusion—for beginning see No. 12 for 1992]

[Text] Conversion presupposes the **utilization of technology for commercial purposes, especially in foreign economic markets.** The Aerospace-90 exhibition in Moscow broke all records for the business activity of Soviet participants. Many of the 120 enterprises of the defense complex that used to work behind the cloak of secrecy took a serious step toward establishing contacts with Western businessmen. The overall amount of contracts that were concluded, as a result, was more than 50 million foreign-currency rubles.

The cause of this high level of activity was the cutbacks in budget appropriations for enterprises, NIIs [scientific-research institutes] and KBs [design bureaus] in the defense complex. A way out of the situation was provided in particular by the commercialization of space research. Some space programs really were literally rescued thanks to contract fees.

Further cutbacks in budget appropriations are entirely likely, and will require a concentration of attention on the commercial utilization of the latest technologies. The direct participation of Western, and especially American, capital in their utilization and development, however, remains problematical. How else can one explain the fact that our specialists who visited America recently were not shown a single missile or space enterprise? Several American delegations, and even former U.S. ambassador to the USSR J. Matlock, have meanwhile visited the Machine-Building Plant imeni M.V. Khrushchev, which puts out that sort of hardware.

But be that as it may, the socio-economic reforms in the country have emancipated foreign economic ties and opened up truly new paths for commercial activity. The Cosmonaut Training Center and the Schwarzwald firm of Zwerger in Germany have developed a fundamentally new conceptual model for marketing that makes it possible to utilize the capabilities of Star City and the industrial potential of German firms. The scientific and technical achievements of domestic space science are opening up prospects for joint industrial production on orbital stations. Our cosmonauts have proved that capability by experimentally growing crystals under weightless conditions. The Center also has at its disposal semi-industrial installations for their production, and in which the enterprises in the electronics industry of Germany are very interested.

The experience accumulated in business collaboration makes it possible to sell successfully the products of intellectual labor and complex technical systems, right up to and including satellites. The country received consumer goods worth 110 million foreign-currency rubles from China in 1990, for instance, in exchange for assistance in space projects. A solid contract has been concluded with India for the launch of communications satellites. Negotiations are underway for commercial launches of the new, ecologically clean Zenit rockets from a cosmodrome being constructed in Australia. That will be a real breakthrough into world markets, from which we are still unambiguously "cut off" owing to various bans.

The launches of cosmonauts from Western countries, space photography from satellites and other projects have great significance in overcoming opposition to—and mistrust of—our technology. Soviet space photography was deemed to be the best in the world at the 12th International Cartographic Conference of the countries of Asia and the Pacific Ocean that was held by the UN. The resolution of the pictures is four meters. These represent enormous capabilities for the creation of super-precise maps. French pictures, by way of example, have a resolution of 10 meters, and American ones 30 meters. Representatives of Thailand, Malaysia, Singapore, Indonesia and Australia have proposed concluding profitable deals with the Main Administration for Cartography. They want to buy pictures of their own territory, even despite the high cost. Other interested countries are still taking a wait-and-see attitude. They are still not able to believe that our industry can create technology better than the West.

Practical steps in foreign economic activity have also been taken by the aviation industry. The KB imeni P.O. Sukhoy, for example, has begun work with the American firm of Gulfstream Aerospace on the creation of a supersonic aircraft. Proposals are currently being studied for the joint production and operation of the largest cargo-carrying aircraft in the world, the An-225 Mriya and the Mi-26 helicopter, with American firms.

The adaptation of military production to the mass output of civilian products, the full-fledged utilization of the scientific and technical potential of the defense complex in the interests of the national economy and the commercialization of military technology all required the creation and functioning of new financial, economic and organizational structures. The State Committee of Russia for Conversion Affairs was formed, the International Conversion Fund (MFK) was created and the Military-Industrial Investment Company (VPIK) and the Russian Investment Joint-Stock Company (RIAO) began their activity in 1991. Just what are they?

The Military-Industrial Investment Company is a credit and finance institution in the form of an open-type joint-stock company. The announced authorized capital is one billion rubles, and the cost of a minimum block of stock is 100,000. The principal investment facilities are the joint-stock enterprises of the defense sectors of industry with high scientific and technical and production potential. Among the founders are the joint-stock company "Military-Industrial Exchange," the Plant imeni M.V. Khrunichev, military unit 57275 and the Military Academy imeni F.E. Dzerzhinskiy, among others.

Two principles are inherent in the work of the International Conversion Fund—profits instead of expenditures, and the ruble is good but the dollar is better. The MFK does not require a single kopeck from the budget. Capital from abroad is moreover being attracted for the conversion of the VPK [military-industrial complex]. There are about 250 military enterprises in its orbit. Divisions have been opened in 24 cities around the country and abroad, in the United States, Austria, Italy, Argentina and Bulgaria. Such extensive ties make it possible to update constantly the most valuable information bank of hard-currency orders, idle production capacity and "breakthrough" technologies. The fund used to assist individual plants in getting out of the debt hole, but now it takes under its tutelage whole conversion regions—Udmurtia, Siberia, St. Petersburg and the Urals.

There are several scientific and technical centers that are part of the MFK. They include the Center for Technologies, which maintains ties with foreign firms, performs the selection of incoming orders and expert appraisals, considers proposals from the point of view of "advantageous" or "not advantageous," makes sales abroad and obtains hard currency. It is also occupied with our domestic problems as well—it performs intermediary functions among military and civilian enterprises and scientific-research institutes, and performs technical and financial expert analysis of proposals submitted. A group of workers at the Central Institute for Aviation Engine

Building [TsIAM] had submitted a plan for the creation of electric-power plants using written-off, "flown-out" aircraft engines. The proposal merited attention, since its realization would have facilitated the pursuit of conversion. But... the financial support for the project was blatantly overstated. TsIAM was asking for 11 million rubles. Representatives of the Center calculated and clarified how they got such a figure. It corresponded to the annual wage fund of all the workers at the institute. But, permit us, why feed the whole institute if only two hundred people in all are working on developing the project? The proposal was returned. The workers of the institute submitted realistic figures a few days later...

New structures are being created right in the defense complex. The Istok Association has registered about 200 joint-stock companies and unique parallel structures, and there are small enterprises as well. The Magratep small enterprise, for example, is operating successfully. Superlight magnets used to be created there on order from the military, and magnetrons and superhigh-frequency generators based on them. The civilian products from the new magnetrons, however, are more profitable: superhigh-frequency chambers with a very broad range of application, from the storage of seed grain to the safe destruction of nuclear wastes. There are just 35 people employed at Magratep, and the administrative apparatus is represented by just one of the former shop chiefs.

The process of conversion of the Armed Forces entails cutbacks in the army, hardware, armaments and defense appropriations, the freeing up and national-economic utilization of resources and the closing of bases, test ranges and other facilities. These measures are commonly relegated to immediate military conversion. Each of them requires independent research. We will dwell on just some of them.

Military enterprises are working, and the scientific-research organizations in the defense complex are continuing to seek out effective methods of destroying, salvaging or making peaceful use of armaments, ordnance and military hardware and reprocessing various types of substances. There are already some results. Small diamonds for the production of diamond tooling, still in short supply in the country, can be obtained from subgrade powders, for example. The prospect of solving the problem of eliminating chemical weapons has been noted. Their destruction could cost 28 billion rubles in 1992 prices, according to the estimates of our military experts. A new technology for obtaining pure arsenic from toxic lewisite, used as a component in chemical weapons, has been developed to make this process less expensive. A compound of arsenic—gallium arsenide—is today replacing silicon semiconductors.

The expensive aircraft that are being taken out of service in aviation should not go to the scrap heap. Options exist for their utilization for peaceful purposes. The Tu-95MS in particular could be used as flying laboratories, as well as employed as effective carriers for containers with fire-extinguishing mixtures when fighting major forest fires. Small satellites or cargo spacecraft could be launched from a Tu-160 missile aircraft as if from a flying cosmodrome. The use of such a system, which has received the name of Burlak, will be many times cheaper than traditional launch vehicles.

Well-thought-out measures to free up and sell military hardware, equipment and various types of assets and to transfer former military facilities and the land they occupy to the national economy are essential in the course of cutting back the armed forces. They are already being pursued.

Some of the outmoded or written-off military hardware is being sold through export organizations. The Navy sold 17 submarines at a price of 140,000—150,000 dollars apiece to the Norwegian firm of Fram Shipping Bermudes through Sudoeksport in 1989. Other countries would also like to acquire our written-off ships and vessels... for scrap metal. A tonne goes for roughly 180 dollars. We ourselves cannot yet reprocess this scrap metal, even though we need it.

Foreign economic activity by the Air Forces seems expedient under the conditions of military conversion. This could include the sale for export of aviation and other hardware that used to be in service, the sale of scientific achievements, technologies and various types of services connected with space research, and the transport of cargo for foreign firms and nations by military-transport.

There is a demand for combat, sport and other aircraft. The MiG-21 is being operated in various countries. A number of protocols of intent have currently been signed to sell Su-25, MiG-23, MiG-27 and Su-17 aircraft. China has already acquired 24 Su-27 fighters from us, and Hungary is asking for three Tu-16 aircraft in order to equip them as laboratories. There is great demand for the MiG-29...

The Air Forces also have internal sources for supplementing their budget. The military aviation repair plants are performing a great deal of work for the civilian sector of the economy. They are repairing aviation hardware and putting out consumer goods in high demand—domestic dishes, electrical household appliances and instruments, tools, gardening implements, sports and tourist goods, health and sanitary equipment, spare parts for motor vehicles and much more. A total of 21.3

million rubles of such goods were produced in 1989. The production volume almost doubled in 1990. Military-transport aviation moreover has been making paid shipments of national-economic freights and charter flights under conversion.

Serious oversights and certain material and financial costs have unfortunately been observed in the conversion of the armed forces. The spending to relocate the troops being withdrawn, accommodate them and provide amenities is too great, and ecological problems are also making themselves felt. Cases of making off with ownerless military hardware, matériel, equipment and even weapons are not rare.

There are serious socio-economic costs to go along with the financial and material ones. The problems of **social conversion** thus merit particular attention. It assumes the resolution of issues of job placement and material, housing and medical support for those being discharged from the armed forces, manual workers and office personnel who are released, as well as people who have worked for a long time at the enterprises and organizations of the VPK.

The acuity of the problem is conditioned by the plans for substantial (to the level of one percent of the population of Russia in peacetime) cutbacks in the armed forces. There were moreover seven million people working in military industry, according to some data, or even 14.4 million according to the estimates of V. Pervyshin. No few civilian enterprises, as is well known, were started up in close cooperation with military industry. The number of people connected with the VPK, according to data from V. Smirnov, approaches half the population of the former USSR when counting those employed in "peaceful industries" supplying products to the VPK, the consumers of the products and the family members of all of the enumerated groups.

Servicemen discharged into the reserves who have not reached pension age and many of the workers and office personnel in the VPK today are in need of retraining, job placement, housing and the solution of other social problems. How many such people are there? It is not yet known. There were 40,000 fliers without apartments in the Air Forces alone at the end of 1991. They are, by and large, the consequence of the withdrawal of troops from the countries of Eastern Europe, plus new resettlers from the Baltics and refugees from Azerbaijan, Georgia, Armenia and other regions. The army still does not have enough bodies, organizations and favorable conditions to obtain a new specialty and find jobs for those discharged into the reserves. Legal, financial and material support for social conversion is essential; some steps have already been taken.



The edict of the President of the Russian Federation titled "Steps to Strengthen Social Protections for Servicemen and Individuals Discharged From Military Service" envisages the payment of a one-time benefit, the transfer of the housing accommodations occupied at no charge and the allocation of plots of land for the construction of residential housing and gardens or orchards, among other things. That is only an insignificant portion of the measures for the social protection of people. The necessity of developing and implementing a comprehensive program has become acute.

The status of state economic policy must be imparted to the conversion of military production. Attempts to orient the gigantic production and economic might of the VPK entirely to the production of consumer goods must be ruled out. That would signify the destruction of our national wealth.

Some of the defense complex should be preserved for its initial purpose, to support the new defense policy of Russia. Most important is where the enterprises of the VPK being converted should be oriented—the utilization of technological and professional potential for the design engineering, production and incorporation of super-modern systems for the output of consumer goods and modern technology for civilian production. That will make it possible to avert the so-called brain drain, and to solve many social problems.

COPYRIGHT: "Aviatsiya i kosmonavtika", 1993.

#### Efforts of Crack Airfield-Services Unit Lauded

93UM0518F Moscow AVIATSIYA I KOSMONAVTIKA  
in Russian No 1, Jan 93 (signed to press 10 Dec 92)  
pp 14-15

[Article by Major N. Chebotarev under the rubric "With the Rear-Services Specialists": "For the Planes to Fly..."]

[Text] *For the uninitiated person far from aviation, all of the people with the blue epaulets are fliers. Tell him that there are twenty or thirty ground specialists for every flier in the Air Forces and he will be surprised. But this is not a case where they say, one does the plowing and seven share the harvest. In aviation everyone has his own "plow," his own row to hoe. And one would scarcely weigh whose burden is the heavier. One thing is undisputed—the labor of all who are affiliated with it is essential for the planes to fly. And more. In aviation everyone, and not just the pilot, can be a true ace even if he is without wings entirely.*

"We have two likely enemies, NATO and ORATO," a pilot I knew said to me half in jest.

I understood NATO. But what was the detached airfield technical support company [ORATO] guilty of?

"The rear-services people, after all, let us down from time to time," he explained. "Either they don't clear the runway in time, or they are late with the lunch for flights. And so much more confusion! So we are 'warring' with them as well..."

This conversation took place a few years ago. Relations with NATO have since improved appreciably. But what about its less global "partner"? The ORATO people are unfortunately still the talk of the town in some places. They themselves do not fly, they say, and they impede the others. Well, not everywhere.

They advised me at the Air Forces headquarters of the Volga Military District, for instance, to write about the "operation" of Major Yerokhin. It has been in first place among the subunits of the aviation rear services for eight years in a row. They come to it from all over the district for its experience.

Yes, a complimentary description. No strains at all?

The "operation" of Yuriy Petrovich Yerokhin is a bulky and cumbersome one. An airfield with a multitude of structures, cafeterias, warehouses and motor pools with the latest vehicles. He has officers, more than a hundred warrant officers and soldiers, workers and office personnel under him.

The rear services support flights day and night. They protect. They feed. They provide clothes and shoes for the pilots, technicians and mechanics. They are concerned with cultural relaxation. The ORATO people, in short, are like in the saying—Jacks of all trades.

Believe what you want, but everything there comes out right. I asked Yuriy Petrovich, how do you manage it?

He smiled good-naturedly. "The work becomes a habit, if you want. We are in a swirl... This is a long discussion, by the way." Then, more seriously, he added, "Why do they get mad at the rear services? Because sometimes they are lazy or are scattered about the unit. Then everything falls apart. We have a rule—don't be lazy and don't make a fuss. Work time is for business. We teach the 'can't-do-it' people, and the lazy we push. And no references whatsoever to unforeseen or other circumstances."

That is probably the solution as to why the fliers do not consider Yerokhin's ORATO to be a "likely adversary." The aviators of other garrisons also respect the company here. They know that aircraft are refueled on time, they are fed well and, if there is a delay in takeoff, they will always find you a place at the hotel at this Volga airfield.

That is even though Yuriy Petrovich complains that dozens of planes and helicopters pass through the airfield. A battalion is really required for their full-fledged support. But there is only a company here. The people work to exhaustion...

It is difficult to say what they think about this "on high," but they do notice the efforts of the ORATO personnel. Last year the company was deemed the best among its kindred subunits. The Air Forces commander-in-chief presented Major Yerokhin with an award.

Behind this evaluation lies, first and foremost, the labor and selflessness of Yerokhin. That is probably in the nature of the officer—give himself over to business without sparing oneself. That is the way he was when he commanded a platoon, when he headed an avto-TECh [motor-vehicle technical maintenance unit], the motor pool of a battalion and when he was fighting in Afghanistan.

"Afghanistan—in my soul" is a beautiful song for some. For Yuriy Petrovich it is two years of his life accompanied by mortal danger. He covered so many mountain roads, risking running over an evil mine or coming under the sniper fire of the mujahedin. He brought twenty one columns through. Each run was unique.

At an airfield close to Fayzabad, nearing the end of fuel and ammunition. The guerrillas were pressing them. The motorized riflemen were asking and imploring—give us some cover from the air! The skies were closed. The only hope was the truck drivers.

"We had to get through. Forget about going back—the mujahedin had just then closed off the road," said commander Yerokhin. "Relieve the infantry."

The efforts that were made on that trip are a special discussion. But Yerokhin brought the column through without losses. And he was awarded the Red Star a few months later. Later, now in Russia, he was awarded the medal "For Distinguished Combat Service."

"The Yerokhin team has clear heads," I heard from the chief of staff of Air Forces rear services in the district, Colonel N. Shebenkov. "It is their intelligence and labor that have created an excellent material and technical base. You have to admire the technical maintenance station. And what a refueling area! The washdown area is a marvel. And all of that is without a single state kopeck. Don't believe it? Wrong... The commander knows how to select personnel. Intelligent and hard-working assistants. Judge for yourself. The commander of the airfield-operations platoon, Warrant Officer A. Lapshov, for example, has been in his position for a year, and has already earned the gratitude of the commanding general of the Air Forces in the district. What talent you need to have to keep the airfield at constant combat readiness through the efforts of eight people! It usually takes a whole company to manage it."

Exercises were underway. The aircraft were waiting at the airfield. Suddenly a weather report—precipitation and a sharp drop in temperatures. The concrete would soon be covered with an icy crust. That meant sending the pilots to a different airfield. But his professionalism did not let Lapshov down. He organized the work correctly and on time. Junior Sergeant Borovskikh and airmen Koshelev, Desyatnikov and Kovalevich worked without stopping. They overcame the bad weather. They helped the pilots to fulfill the combat-training mission.

The commander of the security platoon, Senior Warrant Officer R. Gabdrakhmanov, is also talented. Rashid Nafikovich is a teacher from God. Even desperate characters become good soldiers with him. His subunit has been excellent for eight years. The senior warrant officer has thus been awarded the medals "For Excellence in Military Service" 1st and 2nd degrees.

Or Warrant Officer A. Korolev. He is a Jack of all trades—driver, builder, veterinarian. Veterinarian? And why not, if there are 17 cows and more than a hundred pigs on the company's subsidiary farm, and increasing every year.

The subsidiary farm is not inferior at all to the best farms here. It is profitable. They fulfill the plan for milk and meat by 125 percent. There is always fresh meat, milk and greens on the fliers' table.

It is surprising that there is a competition among the soldiers to work on the subsidiary farm. Yes, a competition. They select the most worthy. Such as airmen S. Tsurkan and A. Akselborn.

The work here, of course, is not the most pleasant. The smell, understandably, is not that of Landysh eau-de-cologne. The "subsidiaries," on the other hand, are guaranteed leave, and the superior officers do not neglect them as well. Airmen Tsurkan and Akselborn have received inscribed watches. Not for their pretty eyes, of course, but for their work. Peasant's work, sweating their guts out.

There is no reason to envy the rear-support people in general. Everyone is always demanding—give, give! And how can you, say, put meat and vegetables on the table under today's market conditions, when there are no centralized deliveries of feed or fertilizers? Counting on the farmers, the representatives of the kolkhozes? Unfortunately, they agree only to barter deals. You give them trucks and spare parts in exchange for grain or feed. That is standard-issue matériel. What can be done here?

And now on the everyday life of the ORATO people. Especially those who support the flights. People are sometimes under the blazing sun or in the freezing cold for whole days at a time. How many years have they been talking about little hut-trailers for the drivers of the

airfield vehicles and airfield workers, where they could rest and, in the winter, warm up? But no. No one has done it. The specialists have thus been contracting radiculitis in the cold cabs of vehicles. True, they do not have long to wait. Yerokhin has resolved to exert himself and build a permanent hut for the duty shift using his own manpower.

And there have been so many nervous strains due to the short staff. People cannot leave the airfield for days at a time, after all. How can one guarantee that this "enthusiasm" will not sometimes lead to an accident through enormous fatigue? No one. The fine companies are kept burning thanks to the selflessness of such officers as Major Yerokhin and senior lieutenants V. Petrov and O. Kazimirov... They have already long passed their time in rank, by the way. And were it up to me, each of them would be awarded an extraordinary rank one step higher than the position they occupy. Believe me, they deserve it.

COPYRIGHT: "Aviatsiya i kosmonavtika", 1993.

#### **Baykonur Deputy Chief Recalls Early Days on Launch Pad**

*93UM0518G Moscow AVIATSIYA I KOSMONAVTIKA in Russian No 1, Jan 93 (signed to press 10 Dec 92) pp 39-41*

[Article by Candidate of Technical Sciences Major-General Valeriy Aleksandrovich Menshikov under the rubric "The Toilers of the Cosmodrome": "The Test Personnel of Baykonur"]

[Text] *The editors of the journal are beginning the publication of materials on those who prepared and executed the launches of spacecraft. Their author—Valeriy Aleksandrovich Menshikov—served at Baykonur for 24 years. He began his activity as a fueling worker, and ended it as the deputy chief of the cosmodrome. His notes tell about people that were behind the veil of secrecy for many long years. The long-awaited glasnost has finally opened up to society the life, service and work of the soldiers/test personnel without whom not a single rocket would have been launched.*

#### **The First Fueling**

I arrived at the cosmodrome on 7 Aug 68, and was assigned to the fueling station for the new N-1 rocket and space system.

The assignment process went quite simply. At the personnel department they asked me, "What is your field?"

"Mechanical engineer," I answered.

"Will you go to fueling?"

"I will," I blurted out, without even thinking of objecting to being assigned outside my field. But that was a common occurrence both at that time and today—getting sent to the sections where there are not enough people.

The fueling group was headed by V. Verbenko—a man two meters tall with a thunderous voice. The second day he entrusted me with a pistol and assigned me to be a sentry at the fueling station, where autonomous tests of systems and their acceptance into operation were underway at the time. That is how my service at the cosmodrome started, and the days, months and years flew by.

I have retained for my whole life my recollections of the first test operation—a fueling of the N-1 technological rocket with the L-3 lunar craft. The equipment was run for ten whole October days, the flaws were "cleaned up" and we acquired skills in working with the most complex rocket and space hardware. The test officers at the time were principally 35—40 years old, without higher education and came from all over. Tankers and artillerymen, pilots and sailors, combat engineers and chemists—in short, it would be easier to list who was not there—were encountered among them.

Our work was finally concluded successfully, and all of the fueling officers assembled in one of the rooms of the structure where Major A. Malov had already cut bread and lard and poured 150 grams of liquor apiece. That was the first time in my life I had tried "fire water." It was my first "fueling" in both a literal and a figurative sense. Frankly speaking, I did not care for it, and I thus subsequently never abused it, even though there were more than enough opportunities for it—liquor flowed like a river at the cosmodrome in those days.

The next day I, a "green" engineer-lieutenant, had to undergo another test. My subordinate, crew member Junior Sergeant V. Okunkov, shared the "secret" that they, the sergeants and soldiers, had also celebrated their first fueling. This was told to me for one purpose—to see if the lieutenant would run to knock at the commander's door or not. I did not, but I warned him that if I saw anybody drunk, there would be no mercy.

#### **Baptism by Fire**

It was in June of 1969 that I first became aware that the testing of space hardware was not only interesting, but also extremely dangerous. The cosmodrome had by that time experienced more than one accident, and more than one launch vehicle had exploded both on the launch pad and in flight. The pain of the loss of test personnel in catastrophes in 1960 and 1963 will never abate in the hearts of those who gave the best years of their own service and lives to the cosmodrome.

The launch of the N-1 was planned for the night hours. I had seen the launch of space rockets and military missiles more than once, but I had never seen the launch of this giant object. As the duty officer for site 112, I was assigned to be responsible for the evacuation of the personnel. Today a lieutenant-colonel at a minimum would be assigned to be responsible for it, but at that time a lieutenant was sufficient. As was set forth in the instructions, I assembled the people, counted them, and then took them by motor vehicle to site 155 (this was the subsidiary farm plot and pigsty of the missile unit of Colonel V. Shirshov), where trenches had been dug ahead of time to shelter the personnel in the event of an emergency.

Matters moved toward night. There were hundreds of vehicles on the roads with soldiers, officers and civilians. They bore combat banners, documents and various matériel. The dust and heat, the roar of the automobile engines, the human chaos, the congestion and traffic jams, the hoarse shouts of the traffic-control personnel—all of this was reminiscent of frames from movies of the first months of the war. The only thing missing was German dive bombers. It seemed that there would not be enough time to the assigned positions, but somehow we did and got settled. The minutes of waiting dragged by. Sitting in the trench and looking at the rocket, we waited for the launch. This was the closest point to the launch pad, something like the front lines in the event of an N-1 accident.

And then it was 18 minutes after midnight. I remembered my whole life that time on the hot July night at Baykonur. We were all looking in the direction of the launch, where the hundred-meter pyramid of the rocket was being readied to be hurled into space. Ignition, the flash of flame from the engines and the rocket slowly rose on a column of flame. And suddenly, at the place where it had just been, a bright fireball. Not one of us understood anything at first. A terrible purple-black mushroom cloud, so familiar from the pictures from the textbook on weapons of mass destruction. The steppe began to rock and the air began to shake, and all of the soldiers and officers froze.

"Get down!" I hollered with all of my might and flopped into the trench. The soldiers, like peas, poured in as well. Some major from the military construction workers landed on top of me in the darkness.

Only in the trench did I understand the sense of the expression "your heart in your mouth." Something quite improbable was being created all around—the steppe was trembling like a vibration test jig, thundering, rumbling, whistling, gnashing—all mixed together in some terrible, seemingly unending cacophony. The trench

proved to be so shallow and unreliable that one wanted to burrow into the sand so as not to hear this nightmare.

The trench was nonetheless decent protection. The shock wave from the explosion passed over us, sweeping away and leveling everything. Behind it came hot metal raining down from above. Pieces of the rocket were thrown ten kilometers away, and large windows were shattered in structures 40 kilometers away. A 400-kilogram spherical tank landed on the roof of the installation and testing wing, seven kilometers from the launch pad.

With God's help, that "attack of iron" also bypassed our trench. When everything quieted down, people started coming out of the shelters. I assembled my subordinates and counted them up. Fortunately, no one had been hurt. All were hale and hearty, just green with fright. To the vehicle on the run, and forward to battle stations. It is impossible to describe what had happened on the roads leading to the burning launch pad of the N-1.

We arrived at the fueling station and were horrified—the windows and doors were smashed out, the iron entrance gate was askew, the equipment was scattered about and it was a mess everywhere. We looked around with the light of dawn and were turned to stone—the steppe was literally strewn with dead animals and birds. Where so many of them came from and how they had appeared in such quantities at the station I still do not understand. The commander of the group, Lieutenant-Colonel Verbenko, and the rest of the officers soon returned—they had been evacuated to a different place. All were fine. The material damage from the destruction of the fueling station alone totaled 350,000 rubles.

Thus I received my baptism in combat as a rocket tester. And then I understood that the conquest of space was not a walk in the park, it was a dangerous as well as difficult path that only courageous people could take.

Space launches have become almost an ordinary thing these days. But every launch remains unique all the same. As unique as the alarming thought that when you look at a majestic rocket, somewhere in the depths of your soul barely and subconsciously fleets the unpleasant chill left from that far-off July night of 1969. Testing rockets is a dangerous craft. Or rather, not a craft but an art, requiring comprehensive knowledge and the highest courage, endurance and patience.

#### Operation "Palm"

The test personnel were diverse people, but were united in one thing—a high sense of responsibility, devotion to space and a readiness for any difficulties and deprivations for the sake of it. This was truly realized when, after two years serving in the fueling group, I was named chief

of the power-engineering division for the launch group. The substance of the dialogue that I had with Lieutenant-Colonel Verbenko before my assignment testified vividly to the fate of the power engineers.

"You're going to the pad?"

"Yes, they consented."

"And you know what kind of accidents they have there?"

"I do."

"And do you know who is to blame for all of those accidents?"

"No, I do not."

"Then I'll tell you, the power engineers are always to blame. The standard scapegoats, so to speak. You want to be one?"

"I do."

"???"

And there I was on the legendary Gagarin pad, where a major overhaul and upgrading had only just been completed.

After that the complex was supposed to be accepted into service, for which a State Commission was created. The work program included performing a test launch of the next planned rocket. Pad chief Major Zhdanovich was commanding the comprehensive check-out at "ground zero." Suddenly there was a direct call from Baranovichi—Mikhail Petrovich's father had died. And I heard Zhdanovich say into the phone in a hushed voice, "Mama, I can't come now, possibly in a week." The commander did not come in a week, or in a month. There was a real "crunch." The systems check-out after the overhaul suffered disruptions and notations, and there was only just enough time for finishing up.

Matters were further aggravated by the fact that the cosmodrome was being readied for the next Palma operation. That is what they called the program of operations in the event of a visit to the test range by the country's leaders and foreign guests. This time they were expecting French President Georges Pompidou, and wanted to surprise him with a "Russian space marvel" as they had at one time during the visit of Charles de Gaulle—the first foreigner permitted at the cosmodrome.

They were preparing the principal launch from site 31 under the supervision of Colonel V. Patrushev. Our launch pad was the back-up, with the launch prepared under the supervision of Colonel Sokolov—chairman of

the State Commission. We would go into action if anything happened at 31, while they would think up some explanation for the guests.

The principal launch went successfully, although not without problems. Our rocket had stood fueled for days, "breathing" oxygen vapors, and the control launch was planned only days after the departure of Pompidou. The oxygen gas content went up to 70 percent in some enclosures of the launch structure, and that situation posed a fire hazard.

But we could do nothing but wait. Truth be told, there is nothing worse than waiting and then catching up. Especially for young people. Our soldiers, essentially boys, prepared for the launch of the rocket with passion and fervor, not stopping for rest or sleep. And then, exhausted from waiting for the next launch, they began to amuse themselves—they began igniting threads permeated with oxygen vapors in the enclosure for the fire-extinguishing water-system pumps, forgetting that their clothing was also saturated. Quite a spectacle—the thread burst into flames and burned just like a Bengal fire. A cigarette, for instance, as was later ascertained in investigation, burned up in one puff.

And then the fire jumped from the burning thread to the soldier. They rushed to put him out. A few seconds later all six of them went up like torches, and they could not be put out. A panicked shout of horror... The fire that broke out near the fueled rocket grew stronger and stronger. The lower part of the launch structure was obscured by solid smoke. The emergency team went into action, barely keeping the stubbornly creeping fire away from the rocket. If the seat of the burning could not be localized, it would reach the rocket quickly, and then an explosion was inevitable. But the fire could not be held back... Tongues of flame were already almost at "ground zero" through the ventilation system.

Launch supervisors colonels V. Sokolov and V. Patrushev (released from his work at site 31), along with industry representative A. Soldatenkov, made the sole correct decision in the prevailing situation—emergency launch! Never before or after this incident in space science did a rocket "make off" from a fire this way. Everything was decided in a few minutes. Everyone who was not engaged in the final operations was rushed away from the burning launch pad. We lowered the girders, evacuated the service compartment, prepared the engines and performed the final operations for the fueling equipment. But the fire was already at the right pylon. Launch! The rocket took off, while tongues of flame several meters high burst into "ground zero" from the ventilation system. The pad was saved. Four dead soldiers were later buried.

The people deserved to have their courage and heroic labor known by the country and the people. But the mass media were not permitted to write about the rocket testers. The road into space thus seemed easy and serene. It was indeed difficult to tell from the features that appeared on space achievements who in fact was launching the craft. It followed from their content that scientists, cosmonauts and highly placed guests of cosmodromes and even military-trade officials were engaged in it. But never mentioned were the names of the chief of the launch group of Lieutenant-Colonel M. Zhdanovich, who served in that post for seven years, team chief Major V. Rakitin, who gave 25 years to the launch team, or division chief Captain S. Grishin, who has 35 years of service on the Gagarin pad. Where were these "invisible people?" Who described the feelings of the soldier or officer when the rocket prepared by him took off into the sky? Who transferred the force of the soldier's or commander's will, born in the form of a passionate friend or subordinate, and the awareness of one's own complete powerlessness? (*To be continued*)

COPYRIGHT: "Aviatsiya i kosmonavtika", 1993.

#### Procedures in Satellite Topography Described

93UM0518H Moscow AVIATSIYA I KOSMONAVTIKA in Russian No 1, Jan 93 (signed to press 10 Dec 92) pp 41-42

[Article by Candidate of Technical Sciences B. Buylin and Candidate of Technical Sciences G. Fomin under the rubric "Space Science for the National Economy": "The 'Kosmos'—A Topographer"]

[Text] The need to create large-scale maps of any territories on the globe with the least material expenditures and in the least time has led to the development of special topographic satellites.

The pictures obtained with their assistance have pictorial and measurement properties. The pictorial properties are characterized by the resolution of the picture-taking system—that is, the ability to transmit small elements of the terrain—and the spectral sensitivity. The measurement properties depend on the errors in determining the coordinates of points on the terrain (objects, contours and the like) by plane and height in some absolute system of coordinates connected with the Earth's surface. The task of obtaining space pictures suitable for cartography is very complex in an engineering sense, and can only be performed by a specialized topographic spacecraft (TKA) combined with ground processing gear—that is, a space topographic system (KTK). How is it accomplished by the satellites of the Kosmos system?

The principal source of information is stereoscopic photographs obtained with a longitudinal overlap of more

than 55 percent, the size of which varies depending on the nature of the relief and the required precision in determining the coordinates (the scale of the map being created). A frame topographic camera (TFA) has been installed on the TKA for that purpose with orthoscopic multiple-lens optics, a mechanism to compensate for image shifting and a mechanism to level the film on a plane, which provides for the subsequent micron precision of the measurements.

In order to establish the dependence between the coordinates of points on the terrain and their images in the picture, it is necessary to determine the angular elements of the external orientation—the angular position of the focal plane at the moment of photography in space (the angles used in photogrametric processing, connected with the angles of pitch, yaw and roll of the spacecraft). If one takes into account that an error in the orientation line of the sighting of 1" at a shooting altitude of 300 kilometers leads to an error of 1.5 meters on the terrain, it becomes clear that the creation of a precision system for the orientation and stabilization of the spacecraft, with errors of a few seconds of angle, is a very complex and expensive matter. There are thus two stellar cameras (ZFA) mounted on the same frame with the TFA, whose main optical axes are at an angle of 30° to each other, for precise determination of the angular elements of the topographic photos (TFS).

These devices make it possible to fix an image of the stars outside the boundaries of the Earth's atmosphere. The material and construction of the frame provide the necessary stability of angles between the main optical axes of the TFA and the two ZFA. The shutters of the stellar and topographic apparatus are actuated in synchrony. It is not difficult to compute the angular elements of the external orientation of a topographic photo, knowing the design angles between the main optical axes of the ZFA and the TFA, by equating the image of the stars with a catalogue of the star sky at the ground station and determining their positions in the systems of coordinates of the stellar gear.

After that one must determine the coordinates of the spacecraft at the moment of opening of the middle of the TFA shutter (that is, the coordinates at the point of photography)—the so-called linear elements of external orientation. Measurements of the position of the TKA relative to three or four satellites in the global navigational system [GNS], as well as measurements using Doppler gear (DPA) relative to astronomical-geodesic points located on the Earth whose coordinates are already known, are used for this purpose.

So-called space leveling is performed in order to determine the height of points on the terrain—a series of measurements over sea level using a high-precision radio altimeter (RV) or laser rangefinder (LD) is made before and after the photographing run.

The joint processing of measurements of elements of external orientation and altitudes makes it possible to determine the parameters of the TKA orbit and the coordinates of the points of photography.

It must be emphasized that all of the measurements and the moments of the opening of the TFA shutters and the stellar gear should be "tied together" with a precision of up to a microsecond per unit time. An on-board synchronizing device using a highly stable frequency generator serves that purpose. It is checked where necessary against time and frequency standards established at ground stations of the command and control system, which are in turn checked against the State Standards for time and frequency.

The topographic camera, stellar gear, radio altimeter, laser rangefinder, receiver for the global navigational system, Doppler gear and on-board synchronization gear

are the whole set of special gear that provides for the receipt of stereoscopic photos with high measurement properties, which can later be tied in with an absolute system of coordinates with a precision that is determined by the scale of the map. The support systems are the traditional ones for a spacecraft.

A topographic photo from orbit with high measurement properties, however, has insufficient pictorial properties. That is why a panoramic slit camera with long-focus optics, operating on the shooting pass simultaneously with the TFA, has been installed on board the TKA.

The presence of a panoramic camera provides the opportunity of simultaneously creating photomaps and photomontages that have the necessary measurement properties. Points on the terrain that are fixed at the moment of actuation of the stellar gear and, consequently, having angular elements of external orientation with a precision

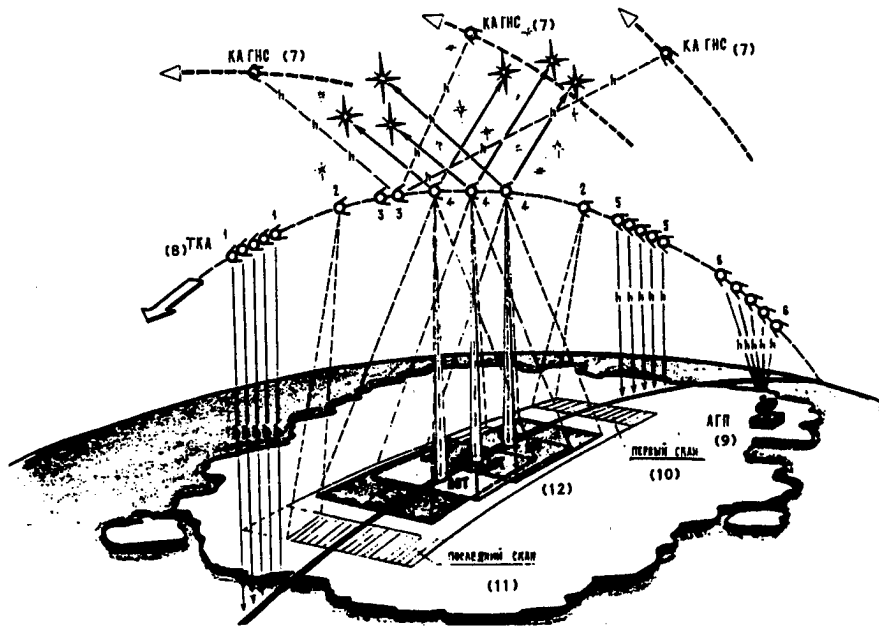

Key:

- |   |                          |
|---|--------------------------|
| 1. turn-on of RV  | 7. satellites of the GNS |
| 2. turn-on of panoramic gear                                      | 8. TKA                   |
| 3. measurement using satellite of the global navigational network | 9. AGP                   |
| 4. turn-on of TFA, ZFA, LD  | 10. first scan           |
| 5. turn-on of RV  | 11. last scan            |
| 6. turn-on of Doppler gear  | 12. LOT                  |

on the same order as the TFS, are present in a panoramic picture. Those same pictures make it possible to identify points on the terrain with greater reliability.

Color film is used instead of black-and-white in the panoramic apparatus to reveal finer structures on the surface being photographed, and to improve the interpretation properties.

It is worth dwelling briefly on the question of control. A daily program of operations for the special gear is drawn up, depending on requests and allowing for priorities and the weather forecast, which is sent to the satellite from the ground command and control stations. The program is altered in the event of a change in the weather conditions in the area of the shooting. The cloud cover is undoubtedly a hindrance, and repeated passes over the necessary regions by maneuvering the TKA in orbit are thus provided for to ensure the required likelihood of the fulfillment of the flight program.

Upon the completion of the flight, all of the information is delivered to Earth in a return craft along with the on-board computer and the topographic, stellar and panoramic gear, which is used over. It then goes to a ground special-processing complex.

Two such spacecraft in the Kosmos series were launched in 1992, making it possible to provide cartographic products not only for Russia and the nations of the CIS, but also for any country in the world.

COPYRIGHT: "Aviatsiya i kosmonavtika", 1993.

#### Articles Not Translated

00000000 Moscow AVIATSIYA I KOSMONAVTIKA  
in Russian No 1, Jan 93 (signed to press 10 Dec 92)

[Text]

Farnborough-92 (S. Skrynnikov) ..... 16-21  
The Last Aircraft (Major A. Khudoyesh) ..... 22

Air Aces (P. Bogdanov, A. Shcherbakov) ..... 23, 26  
The S-5 (Colonel V. Zaretskiy) ..... 26-27  
The Wings of Russia (V. Tkachev) ..... 28-30  
"...Whence the Fellow's Chinese Melancholy?" (Major N. Starodymov) ..... 30-31  
The MiG-15 Versus the Saber (N. Yakubovich) . 32-33  
The "Blue Angels" (Lieutenant-Colonel V. Bondar, Lieutenant-Colonel S. Valchenko) ..... 34-38  
The "Courier" of Lunar Soil and Hot Plates... (I. Federov, A. Karpov) ..... 43  
The Flights That Never Happened... (S. Shamsutdinov, I. Marinin) ..... 44-45  
Instead of Hatha-Yoga (V. Fokhtin) ..... 46-47  
The Commander's "Hundred" (Colonel A. Kanevskiy) . 48  
In the Skies of Moscow—"Air Squadron" (Lieutenant-Colonel M. Syrtlanov) ..... C3

COPYRIGHT: "Aviatsiya i kosmonavtika", 1993.

#### Publication Data

93UM0518J Moscow AVIATSIYA I KOSMONAVTIKA  
in Russian No 1, Jan 93 (signed to press 10 Dec 92) pp

[Text]

English title: AVIATION AND COSMONAUTICS

Russian title: AVIATSIYA I KOSMONAVTIKA

Editor: V.V. Anuchin

Publishing house: Voenizdat

Date of publication: January 1993

Signed to press: 10 Dec 92

COPYRIGHT: "Aviatsiya i kosmonavtika", 1993.



NTIS  
ATTN PROCESS 103  
5285 PORT ROYAL RD  
SPRINGFIELD VA

2

22161

BULK RATE  
U.S. POSTAGE  
PAID  
PERMIT NO. 352  
MERRIFIELD, VA.

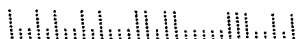

This is a U.S. Government publication. Its contents in no way represent the policies, views, or attitudes of the U.S. Government. Users of this publication may cite FBIS or JPRS provided they do so in a manner clearly identifying them as the secondary source.

Foreign Broadcast Information Service (FBIS) and Joint Publications Research Service (JPRS) publications contain political, military, economic, environmental, and sociological news, commentary, and other information, as well as scientific and technical data and reports. All information has been obtained from foreign radio and television broadcasts, news agency transmissions, newspapers, books, and periodicals. Items generally are processed from the first or best available sources. It should not be inferred that they have been disseminated only in the medium, in the language, or to the area indicated. Items from foreign language sources are translated; those from English-language sources are transcribed. Except for excluding certain diacritics, FBIS renders personal names and place-names in accordance with the romanization systems approved for U.S. Government publications by the U.S. Board of Geographic Names.

Headlines, editorial reports, and material enclosed in brackets [ ] are supplied by FBIS/JPRS. Processing indicators such as [Text] or [Excerpts] in the first line of each item indicate how the information was processed from the original. Unfamiliar names rendered phonetically are enclosed in parentheses. Words or names preceded by a question mark and enclosed in parentheses were not clear from the original source but have been supplied as appropriate to the context. Other unattributed parenthetical notes within the body of an item originate with the source. Times within items are as given by the source. Passages in boldface or italics are as published.

#### SUBSCRIPTION/PROCUREMENT INFORMATION

The FBIS DAILY REPORT contains current news and information and is published Monday through Friday in eight volumes: China, East Europe, Central Eurasia, East Asia, Near East & South Asia, Sub-Saharan Africa, Latin America, and West Europe. Supplements to the DAILY REPORTs may also be available periodically and will be distributed to regular DAILY REPORT subscribers. JPRS publications, which include approximately 50 regional, worldwide, and topical reports, generally contain less time-sensitive information and are published periodically.

Current DAILY REPORTs and JPRS publications are listed in *Government Reports Announcements* issued semimonthly by the National Technical Information Service (NTIS), 5285 Port Royal Road, Springfield, Virginia 22161 and the *Monthly Catalog of U.S. Government Publications* issued by the Superintendent of Documents, U.S. Government Printing Office, Washington, D.C. 20402.

The public may subscribe to either hardcover or microfiche versions of the DAILY REPORTs and JPRS publications through NTIS at the above address or by calling (703) 487-4630. Subscription rates will be

provided by NTIS upon request. Subscriptions are available outside the United States from NTIS or appointed foreign dealers. New subscribers should expect a 30-day delay in receipt of the first issue.

U.S. Government offices may obtain subscriptions to the DAILY REPORTs or JPRS publications (hardcover or microfiche) at no charge through their sponsoring organizations. For additional information or assistance, call FBIS, (202) 338-6735, or write to P.O. Box 2604, Washington, D.C. 20013. Department of Defense consumers are required to submit requests through appropriate command validation channels to DIA, RTS-2C, Washington, D.C. 20301. (Telephone: (202) 373-3771, Autovon: 243-3771.)

Back issues or single copies of the DAILY REPORTs and JPRS publications are not available. Both the DAILY REPORTs and the JPRS publications are on file for public reference at the Library of Congress and at many Federal Depository Libraries. Reference copies may also be seen at many public and university libraries throughout the United States.