

ARMY RESEARCH LABORATORY



Examination of BSU-86/B Setscrews

Marc S. Pepi

ARL-MR-379

NOVEMBER 1997

19971217 089

DTIC QUALITY INSPECTED 8

Approved for public release; distribution is unlimited.

The findings in this report are not to be construed as an official Department of the Army position unless so designated by other authorized documents.

Citation of manufacturer's or trade names does not constitute an official endorsement or approval of the use thereof.

Destroy this report when it is no longer needed. Do not return it to the originator.

Army Research Laboratory

Aberdeen Proving Ground, MD 21005-5066

ARL-MR-379

November 1997

Examination of BSU-86/B Setscrews

Marc S. Pepi
Weapons & Materials Research Directorate

Approved for public release; distribution is unlimited.

DTIC QUALITY INSPECTED 5

Abstract

A total of four used and four new setscrews from a BSU-86/B bomb fin assembly were examined to determine the probable cause of internal socket head stripping. The intent was to compare the properties of the used setscrews to those of the new. The U.S. Army Research Laboratory (ARL), Weapons and Materials Research Directorate (WMRD), performed a dimensional verification to ensure that the parts undergoing investigation met the governing requirements. The wall thickness at the internal socket points was found to be less than nominal in most setscrews. The chemical composition of two used and two new bolts compared favorably to American Institute for Steel and Iron (AISI) 4037 steel, which was in accordance with the governing requirement. The core hardness of the parts fell within the required range. Vickers microhardness profiles from the surface of the parts showed that a gradient existed in one of the used and in one of the new setscrews. Metallography was subsequently used to determine the cause of the hardness gradients. A layer of total decarburization was revealed on most of the setscrews upon etching with 2% nital. Although the thickness of the layer met the requirements of FF-S-200, the presence of "total" decarburization was not in accordance with MIL-H-6875 for Class A material. The microstructure of each setscrew examined was finely tempered martensite, which conformed to an austenitized, quenched, and tempered part. It was concluded that no trends existed between the used and new setscrews examined. Recommendations were offered concerning the required torque, as well as the use of automatic tools.

TABLE OF CONTENTS

	<u>Page</u>
LIST OF FIGURES	v
LIST OF TABLES	vii
1. BACKGROUND	1
2. DIMENSIONAL VERIFICATION	2
3. APPLICABLE SPECIFICATIONS	3
4. CHEMICAL ANALYSIS	4
5. HARDNESS TESTING	5
5.1 Rockwell Hardness Testing	5
5.2 Vickers Microhardness Testing	6
6. METALLOGRAPHY	7
7. RECOMMENDED TORQUE	16
8. DISCUSSION	16
9. CONCLUSIONS	16
10. RECOMMENDATIONS	17
11. FUTURE WORK	17
DISTRIBUTION LIST	19
REPORT DOCUMENTATION PAGE	21

INTENTIONALLY LEFT BLANK

LIST OF FIGURES

<u>Figure</u>	<u>Page</u>
1. Photograph of the Four Used Setscrews in the As-Received Condition	1
2. Representative Used Setscrew in the As-Received Condition	2
3. Representative New Setscrew in the As-Received Condition	2
4. Schematic Illustrating the Dimensions Measured by ARL	3
5. Schematic Illustrating Location of Sectioning	6
6. Lap Located Within a Root of Setscrew N1	8
7. Microcracking Noted Along a Thread Flank of Setscrew U1	8
8. Microcracking Noted Along a Thread Flank of Setscrew U4	9
9. Vickers Microhardness Profile Along the Tip of a Thread From Setscrew U1	11
10. Vickers Microhardness Profile Along the Tip of a Thread From Setscrew U4	11
11. Vickers Microhardness Profile Along the Tip of a Thread From Setscrew N1	12
12. Vickers Microhardness Profile Along the Tip of a Thread From Setscrew N2	12
13. Vickers Microhardness Profile Along the Tip of a Thread From Setscrew U1 at Higher Magnification	13
14. Vickers Microhardness Profile Along the Tip of a Thread From Setscrew N2 at Higher Magnification	13
15. Vickers Microhardness Profile Along the Socket of Setscrew U1	14
16. Vickers Microhardness Profile Along the Socket of Setscrew U4	14
17. Vickers Microhardness Profile Along the Socket of Setscrew N1	15
18. Vickers Microhardness Profile Along the Socket of Setscrew N2	15

INTENTIONALLY LEFT BLANK

LIST OF TABLES

<u>Table</u>		<u>Page</u>
1.	Dimensional Verification	4
2.	Chemical Composition	5
3.	Results of Rockwell Hardness Testing HRC, 150-kg Major Load	6
4.	Results of Microhardness Testing Vickers Scale, 50-g Major Load	7
5.	Extent of Microcracking	9
6.	Classification of Decarburization	10
7.	Extent of Decarburization	10

INTENTIONALLY LEFT BLANK

EXAMINATION OF BSU-86/B SETSCREWS

1. BACKGROUND

The U.S. Army Research Laboratory (ARL) Weapons and Materials Research Directorate (WMRD) was tasked by the Naval Air Warfare Center (NAWC) to examine four BSU-86/B setscrews that had been in service (used) and to compare them to 20 setscrews taken from inventory (new). These setscrews are used to fasten the BSU-86/B bomb fins to general purpose bombs. The setscrew is listed on Naval Air Systems Command (NAVAIRSYSCOM) Drawing No. 2877751 and is required to conform to the requirements of Military Standard MS 51963, *Setscrew - Hexagon Socket, Cup Point, Alloy Steel, Cadmium Plated, UNC - 3A, Plain and Self-Locking*. The used setscrews consisted of two with stripped sockets and two with relatively intact sockets (see Figure 1). A typical in-service setscrew is shown in Figure 2. Figure 3 shows a typical setscrew from inventory, designated as "new" within the context of this report. The examination performed by ARL consisted of dimensional verification, chemical analysis, hardness testing, and metallography. Recommendations were offered to prevent stripping of the sockets during installation.

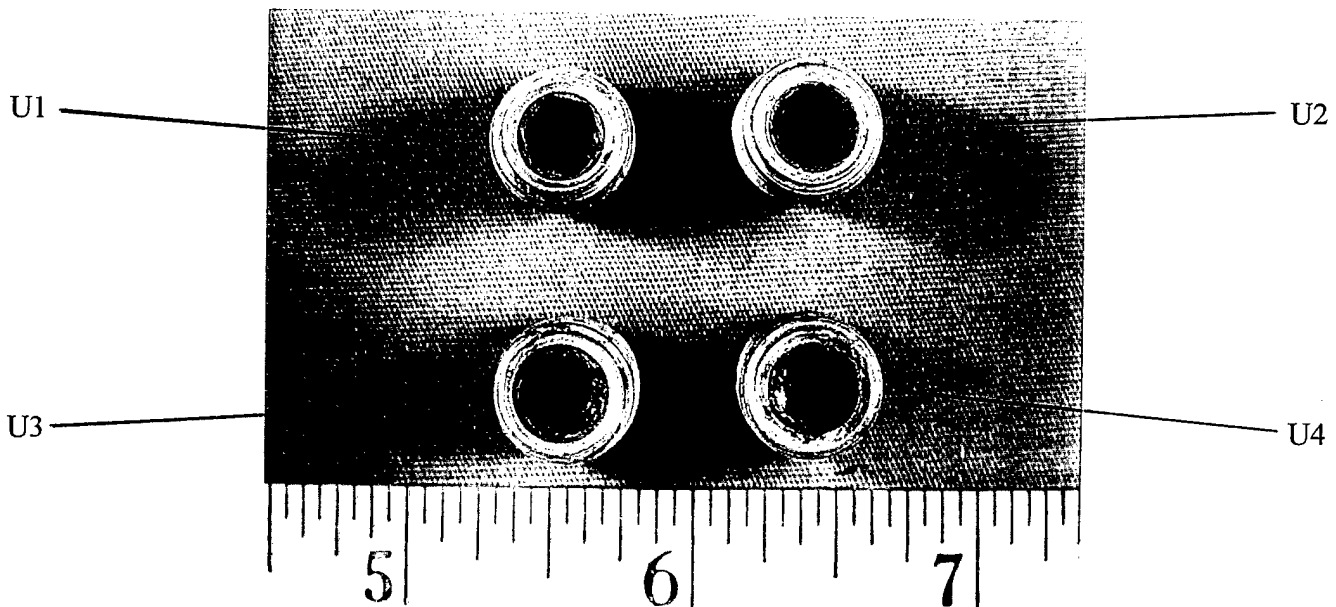

Figure 1. Photograph of the Four Used Setscrews in the As-Received Condition. (U1 represents the setscrew with the most intact socket, while U4 represents the setscrew with the worst stripped socket.)

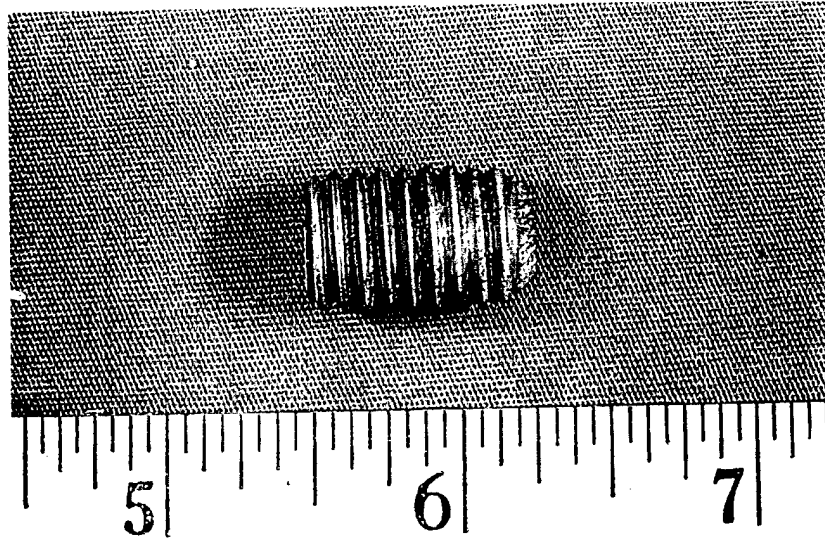

Figure 2. Representative Used Setscrew in the As-Received Condition.

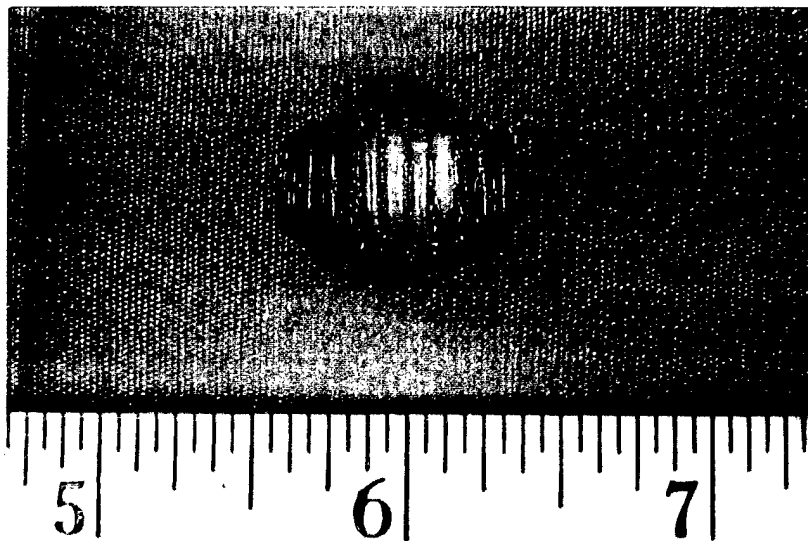

Figure 3. Representative New Setscrew in the As-Received Condition.

2. DIMENSIONAL VERIFICATION

Dimensions were measured on each of the four used setscrews and on four of the twenty setscrews from inventory. The nominal dimensions were listed in MS 51963. Measurements taken on used setscrews should be regarded with caution, since the parts may have undergone dimensional changes in service because of installation and wear. The results of these measurements are listed in Table 1. The nomenclature "U" reflects "used" setscrews, while "N" symbolizes "new" parts. Designations U1 through U4 indicate the order of decreasing as-received condition (i.e., U1 was the used setscrew in the best overall condition, while U4 was the used setscrew in the worst overall condition). The measured wall thicknesses were slightly less than nominal for both used and new parts. A thin wall section could help promote the longitudinal cracking noted previously by the NAWC on similar setscrews. Figure 4 illustrates the dimensions measured.

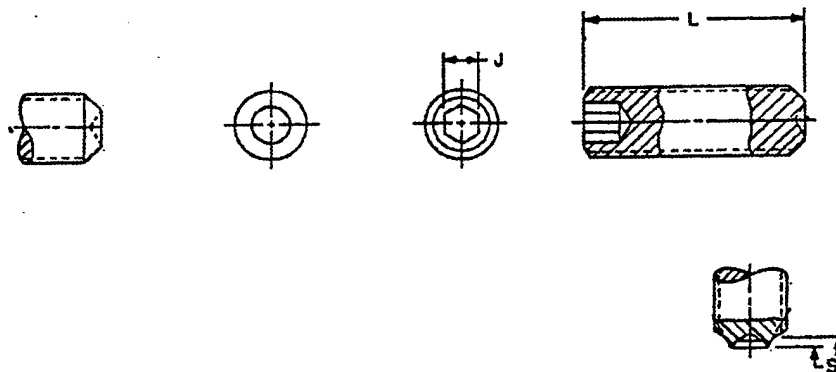

Figure 4. Schematic Illustrating the Dimensions Measured by ARL.

3. APPLICABLE SPECIFICATIONS

- NAVAIRSYSCOM Drawing 2877751, "Setscrew"
 - MS51963, "Setscrew-Hexagon Socket, Cup Point, Alloy Steel, Cadmium Plated, UNC-3A, Plain and Self-Locking"
 - MIL-S-7742, "Screw Threads, Standard, Optimum Selected Series: General Specification For"
 - FF-S-200, "Setscrews: Hexagon Socket and Spline Socket, Headless"
 - MIL-H-6875, "Heat Treatment of Steel, Process For"
- MIL-F-18240, "Fastener Element, Self-Locking, Threaded Fastener, 250° F Maximum"

Table 1

Dimensional Verification

Dimension	Requirement	U1	U2	U3	U4	N1	N2	N3	N4
Diameter	0.500 nominal	0.494	0.489	0.493	0.493	0.499	0.495	0.497	0.491
Threads/inch	13	13	13	13	13	13	13	13	13
J	0.250 nominal	0.257	0.268	*	*	0.259	0.258	0.254	0.257
Length	0.750 \pm 0.02	0.760	0.747	0.747	0.753	0.757	0.764	0.753	0.761
Wall Thick ¹	0.106 nominal ²	0.099	0.090	*	*	0.099	0.099	0.102	0.097
S	0.049-0.054	0.053	*	*	*	0.050	0.053	0.049	0.049

Dimensions are expressed in inches

*This could not be measured because of the poor condition of the used setscrews

¹Nominal wall thickness was calculated as follows:

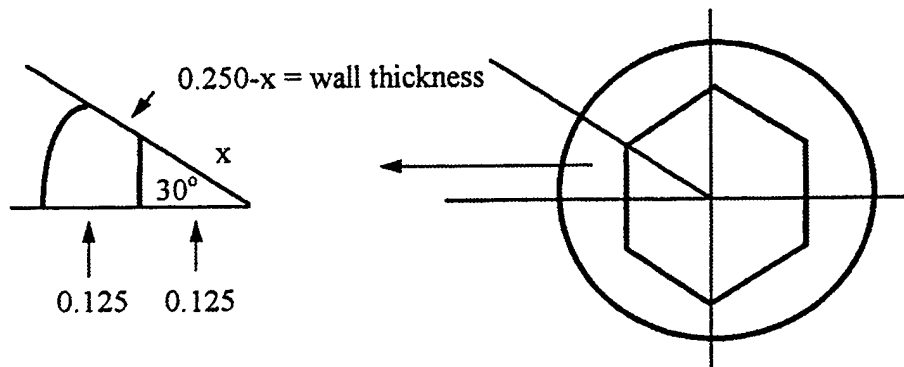

²Assumes 0.500-diameter setscrew, 0.250 "J" value, and socket centered within the setscrew

J = socket width across flats

S = point length

4. CHEMICAL ANALYSIS

Sections of setscrews U1, U4, N1, and N2 were analyzed for elemental composition.

Table 2 contains the results of this analysis. Specification FF-S-200 (the MS 51963 procurement specification) lists the following materials from which the setscrews should be manufactured; AISI 4032, 4037, 4137, 4140, 8630, 8740 or equivalent. The compositions of each of the setscrews analyzed compared favorably to AISI 4037 and therefore met the requirements of the governing specification.

Table 2
Chemical Composition

Element	U1	U4	N1	N2	AISI 4037
	Weight Percent	Weight Percent	Weight Percent	Weight Percent	Weight Percent
Carbon	0.38	0.38	0.36	0.36	0.35 - 0.40
Sulfur	0.042	0.029	0.035	0.038	0.040 max.
Aluminum	0.020	0.025	0.025	0.024	*
Chromium	0.050	0.084	0.13	0.12	*
Copper	0.045	0.11	0.13	0.13	*
Manganese	0.82	0.76	0.90	0.90	0.70 - 0.90
Molybdenum	0.21	0.20	0.21	0.22	0.20 - 0.30
Nickel	0.033	0.092	0.10	0.099	*
Phosphorus	0.007	0.006	0.007	0.007	0.035 max.
Silicon	0.20	0.23	0.29	0.28	0.15 - 0.30

* - Not listed for the AISI 4037 alloy

5. HARDNESS TESTING

Rockwell hardness and Vickers microhardness testing was performed on two used and two new setscrews. The purpose of the Rockwell testing was to verify the prior heat treatment and compare the results with the required hardness range. The purpose of the microhardness testing was to determine if a hardness gradient existed from the surface to the core of the components.

5.1 Rockwell Hardness Testing

The setscrews were required to have a hardness of 45 to 53 hardness Rockwell "C" (HRC) according to Military Standard MS 51963. Used setscrews U1 and U4 were tested, as well as N1 and N2. The parts were sectioned as shown in Figure 5 and mounted in phenolic powder. The mounts were metallographically prepared and subjected to Rockwell hardness testing. Each setscrew conformed to the governing requirement, and no appreciable differences were noted between the hardness of the used versus the hardness of the new setscrews, as listed in Table 3.

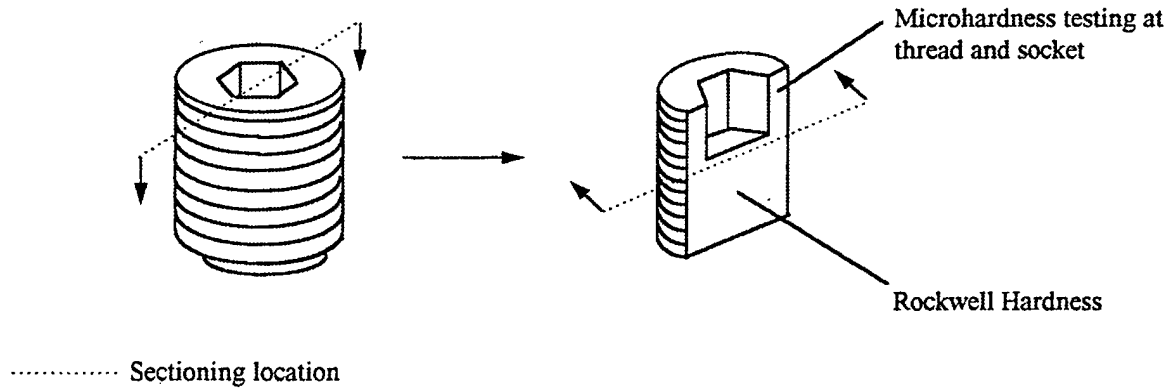

Figure 5. Schematic Illustrating Location of Sectioning.

Table 3

Results of Rockwell Hardness Testing
HRC, 150-kg Major Load

U1	U4	N1	N2
46.7	47.5	48.1	46.8
47.4	48.0	47.5	47.2
47.3	48.2	47.7	47.2
47.6	48.0	47.9	47.6
47.4	48.2	47.7	47.5
Average = 47.3 HRC	Average = 48.0 HRC	Average = 47.8 HRC	Average = 47.3 HRC
Required = 45-53 HRC	Required = 45-53 HRC	Required = 45-53 HRC	Required = 45-53 HRC

5.2 Vickers Microhardness Testing

Microhardness profiles were taken in two regions of setscrews U1, U4, N1, and N2. The first profile extended from the tip of a thread to approximately 0.25 inch into the core of the part. The second profile extended from the inner surface of the socket to approximately 0.20 inch into the core. In each case, the first reading measured approximately 0.001 inch from the edge of the specimen. The readings were spaced 0.002 inch from each other. A load of 50 grams was used in order to obtain a smaller indent, which would allow for more readings in the area of interest. Since this load is less than 500 grams, care should be taken when correlating the Vickers readings to equivalent Rockwell numbers. In general, the readings indicated that a softer surface layer existed on U1 and N2, most likely caused by the presence of a decarburized layer (see metallography section). The results of this testing are listed in Table 4.

The data show that the surface of the thread tips was much softer for setscrews U1 and N2, while setscrews U4 and N1 did not show such a wide gradient. The same trend was noted with the surface of the socket. The socket of U4 did not contain a decarburized layer. However, the decarburization may have been worn off as a result of the socket being stripped. The bold row within Table 4 indicates the depth at which there should be no evidence of decarburization per Figure 1 of FF-S-200 (0.012 inch). The hardness of each setscrew at this depth was not affected by the decarburized layer and therefore conformed to the governing requirement.

Table 4
Results of Microhardness Testing
Vickers Scale, 50-g Major Load

U1				U4				N1				N2			
Thread		Socket		Thread		Socket		Thread		Socket		Thread		Socket	
HV	Loc.	HV	Loc.	HV	Loc.	HV	Loc.	HV	Loc.	HV	Loc.	HV	Loc.	HV	Loc.
175	.001	237	.001	418	.001	453	.001	418	.001	429	.001	237	.001	289	.001
336	.003	341	.003	466	.003	447	.003	441	.003	460	.003	376	.003	401	.003
349	.005	418	.005	441	.005	466	.005	447	.005	447	.005	412	.005	429	.005
367	.007	453	.007	460	.007	453	.007	453	.007	447	.007	435	.007	447	.007
423	.009	473	.009	447	.009	453	.009	447	.009	473	.009	435	.009	447	.009
435	.011	473	.011	447	.011	447	.011	447	.011	480	.011	435	.011	434	.011
435	.013	460	.013	466	.013	459	.013	453	.013	473	.013	423	.013	460	.013
429	.015	473	.015	453	.015	459	.015	453	.015	466	.015	447	.015	480	.015
441	.017	447	.017	466	.017	466	.017	453	.017	480	.017	447	.017	494	.017
423	.019	494	.019	441	.019	466	.019	460	.019	480	.019	429	.019	441	.019
429	.021			447	.021			447	.021			447	.021		
441	.023			453	.023			441	.023			435	.023		
435	.025			447	.025			460	.025			435	.025		
447	.027			460	.027			460	.027			447	.027		

6. METALLOGRAPHY

Metallography was used to confirm the presence of decarburization along the periphery of the setscrews. The setscrews that were sectioned and mounted for microhardness testing were subsequently metallographically prepared. The samples were first examined in the as-polished condition. The samples were relatively clean and exhibited no appreciable inherent material defects. Some surface laps were noted in the roots of some threads, as shown in Figure 6. This particular lap was found in a thread root of setscrew N1. Along the surface of the samples, areas of microcracking were also noted. These cracks were filled with cadmium, which indicated that they were present before the plating operation. The amount of cracking varied from setscrew to setscrew, as well as from thread root to thread tip. This cracking was not noted along the socket surfaces. The cracking along a thread flank of the U1 setscrew is shown in Figure 7, which represented the worst case

scenario. This cracking was heavier than that noted along the flank of the U4 setscrew (see Figure 8). Table 5 summarizes the extent of the cracking noted. No comparison could be drawn between the used versus the new setscrews; however, the heaviest areas of microcracking correlated to the regions of heaviest decarburization.

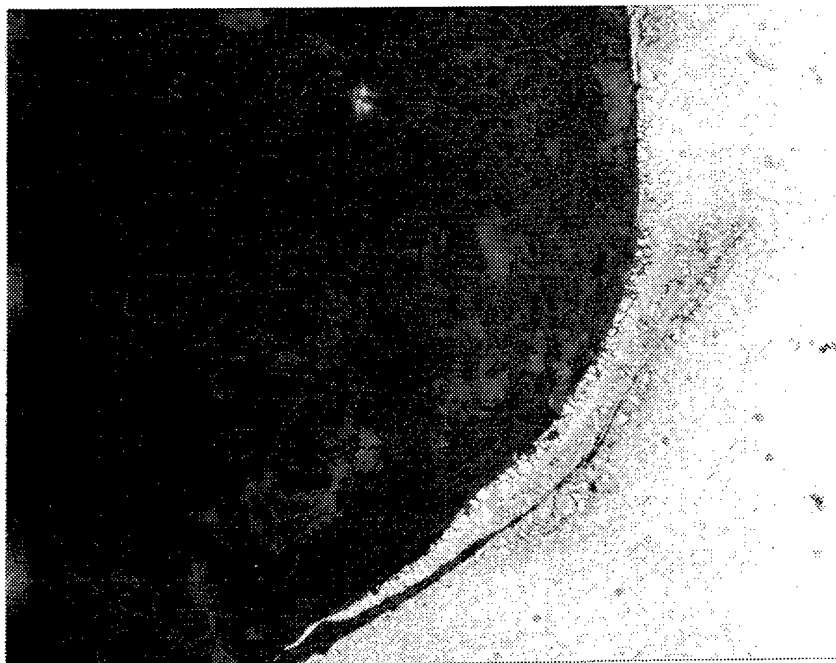

Figure 6. Lap Located Within a Root of Setscrew N1 (magnification 300x).

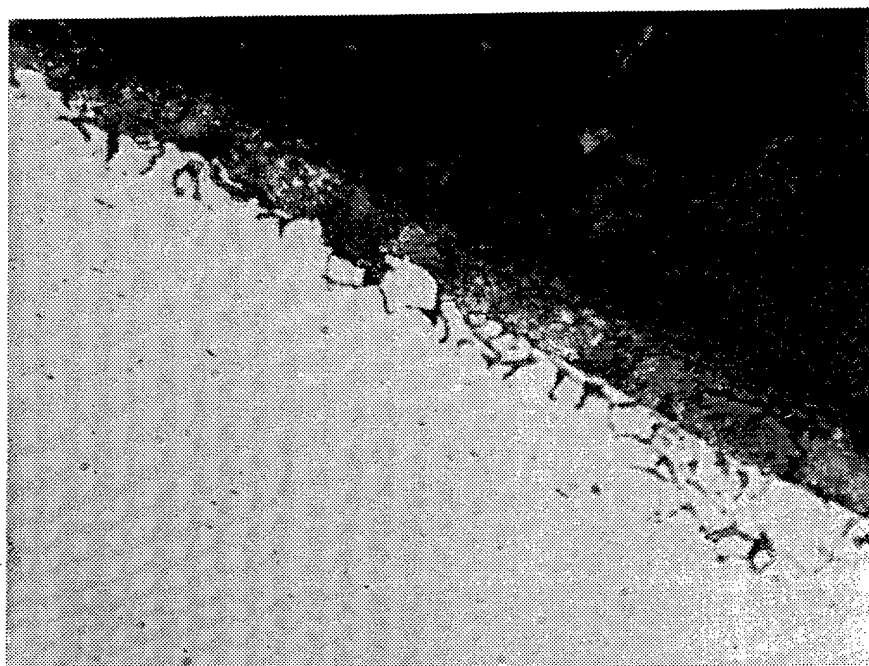

Figure 7. Microcracking Noted Along a Thread Flank of Setscrew U1 (magnification 1000x).

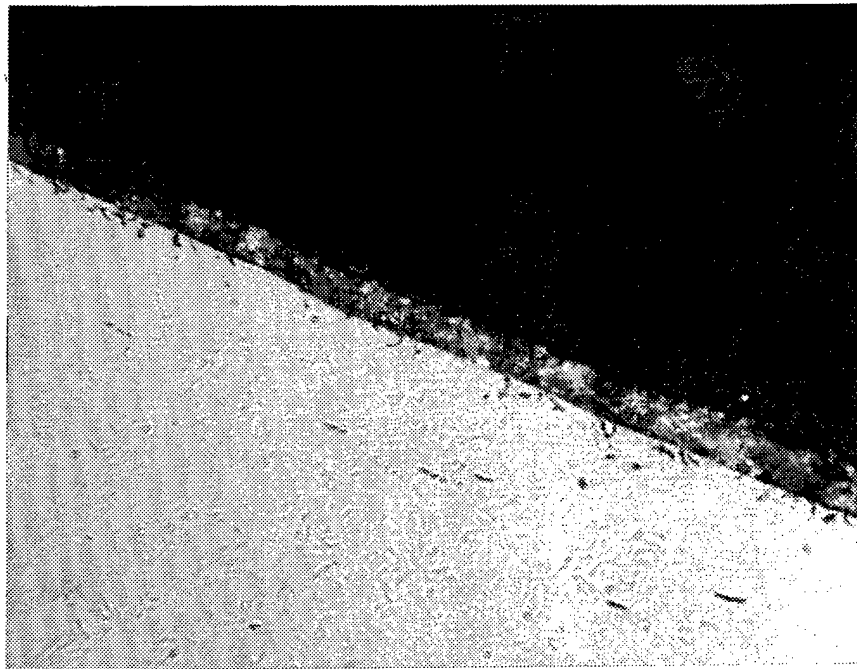

Figure 8. Microcracking Noted Along a Thread Flank of Setscrew U4 (magnification 1000x).

Table 5

Extent of Microcracking

U1			U4			N1			N2		
Root	Flank	Tip	Root	Flank	Tip	Root	Flank	Tip	Root	Flank	Tip
L-M	H	H	L	L	L	L-M	L-M	L-M	H	H	H

L = Light amount of microcracking
 M = Medium amount of microcracking
 H = Heavy amount of microcracking

The samples were subsequently etched in 2% nital etchant and examined optically. Regions of total decarburization were noted on each sample, except setscrew U4. The presence of total decarburization is prohibited per paragraph 3.3.3.1 of MIL-H-6875. Table 6 lists the regions that exhibited decarburization.

¹Decarburization is classified as either total or partial (incomplete or complete). Total carburization consists of a full layer of ferrite, followed by a transition zone. Partial decarburization resembles total; however, precipitates exist within the ferrite grains.

Table 6

Classification of Decarburization

U1		U4		N1		N2	
Threads	Socket	Threads	Socket	Threads	Socket	Threads	Socket
T	T	N	N	T*	N	T	T

T - Total decarburization

N - Negligible decarburization

* - Layer of total decarburization was only found on a few of the threads.

Figure 1 of Specification FF-S-200 states that the maximum depth of decarburization must not exceed 0.012 inch for this particular setscrew (13 threads per inch). However, this figure only shows partial decarburization limits and does not address total decarburization. The depth of decarburization was measured for setscrews U1, U4, N1, and N2. The measurements are listed in Table 7.

Table 7

Extent of Decarburization

U1		U4		N1		N2	
Threads	Socket	Threads	Socket	Threads	Socket	Threads	Socket
0.002 in.	0.002 in.	N	N	0.008 in.	N	0.004 in.	0.008 in.

N - Negligible decarburization.

Figures 9 through 12 show the Vickers microhardness profiles taken from the thread tips of U1, U4, N1, and N2, respectively. Note that the setscrews with the heaviest amount of cracking (see Table 5) also exhibited the lowest surface hardness (see microhardness results) and the heaviest amount of surface decarburization (see Figures 9 and 12). Figure 13 shows a magnified view of the hardness indents at the tip of the thread of U1. Note that the indent located within the decarburized layer (white layer) is larger than the other indents. This shows that the decarburized layer is much softer than the transition zone and core. Figure 14 shows the decarburized layer at the thread tip of N2. Figures 15 through 18 show the hardness indents at surface of the socket for U1, U4, N1, and N2, respectively. Note the decarburization on U1 (see Figure 15) and N2 (see Figure 18).

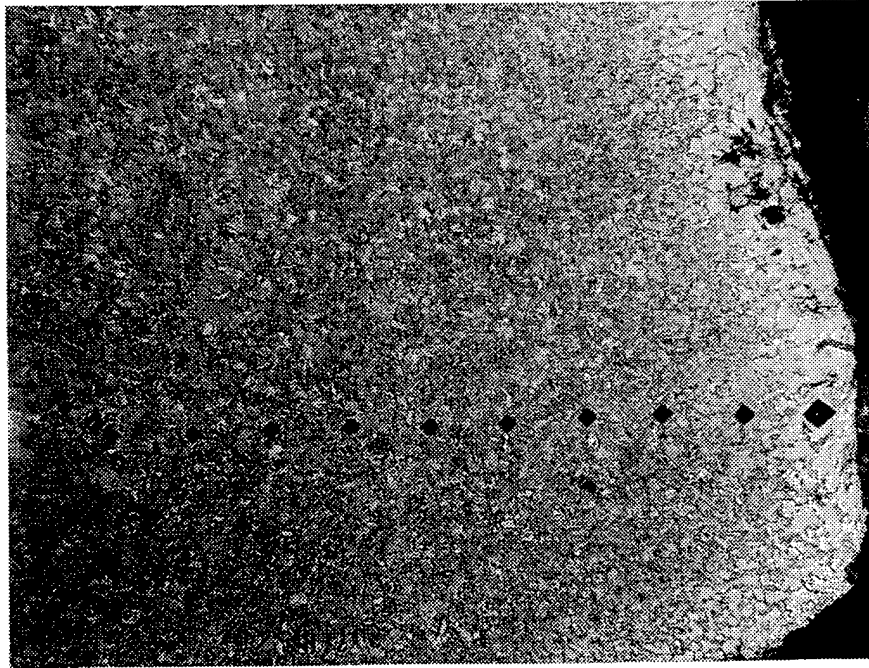

Figure 9. Vickers Microhardness Profile Along the Tip of a Thread From Setscrew U1. (Note the layer of decarburization along the tip of the thread; magnification 200x.)

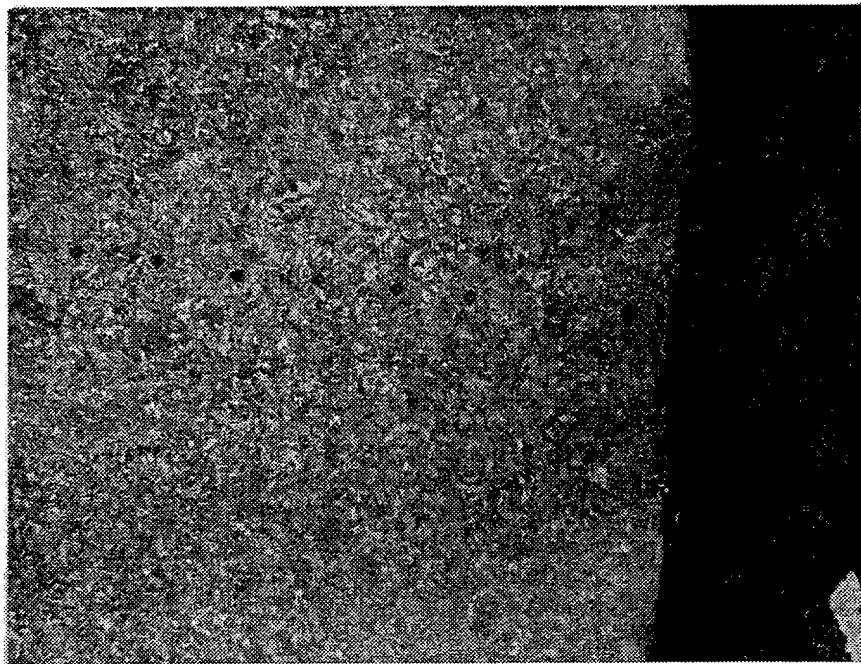

Figure 10. Vickers Microhardness Profile Along the Tip of a Thread From Setscrew U4 (magnification 200x).

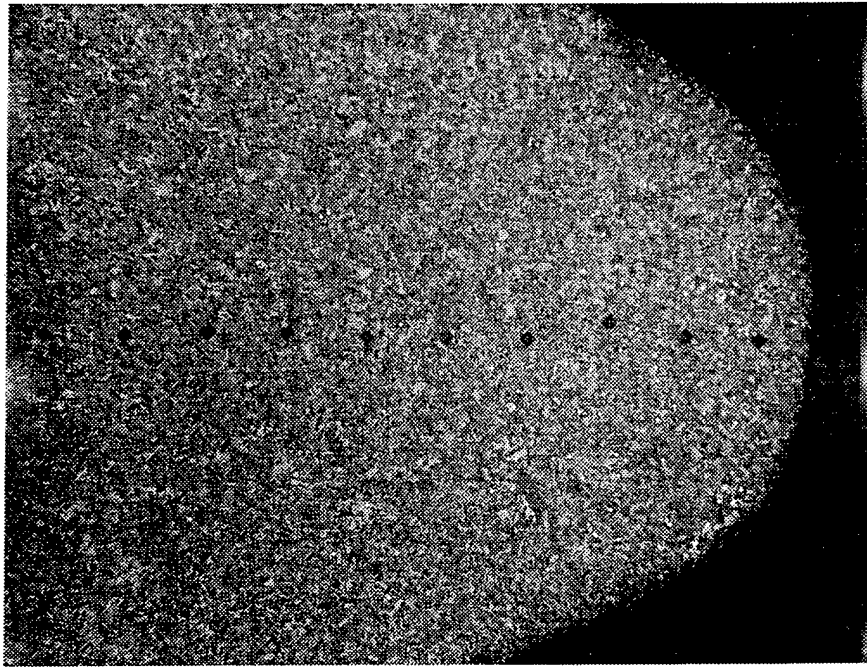

Figure 11. Vickers Microhardness Profile Along the Tip of a Thread From Setscrew N1 (magnification 200x).

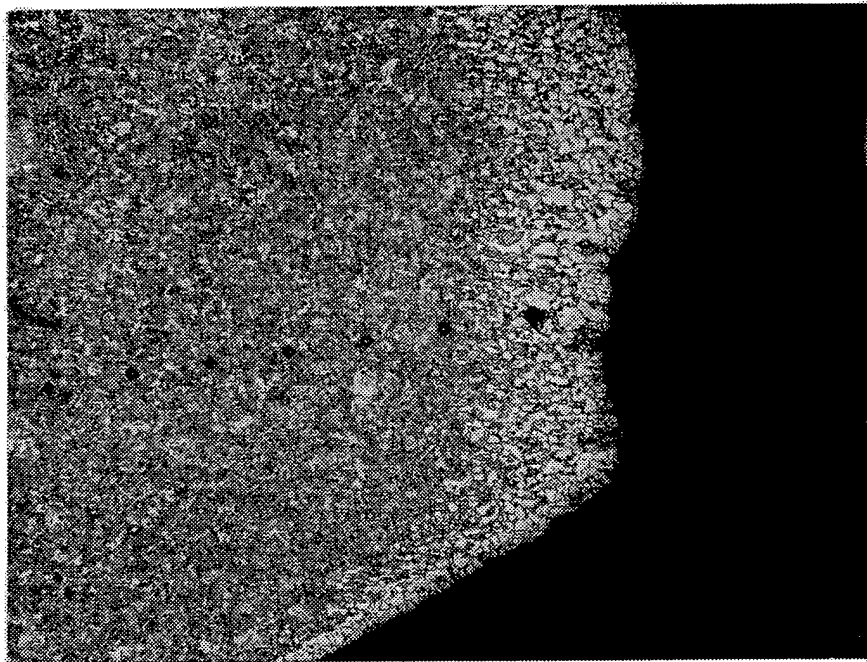

Figure 12. Vickers Microhardness Profile Along the Tip of a Thread From Setscrew N2. (Note the layer of decarburization along the tip of the thread; magnification 200x.)

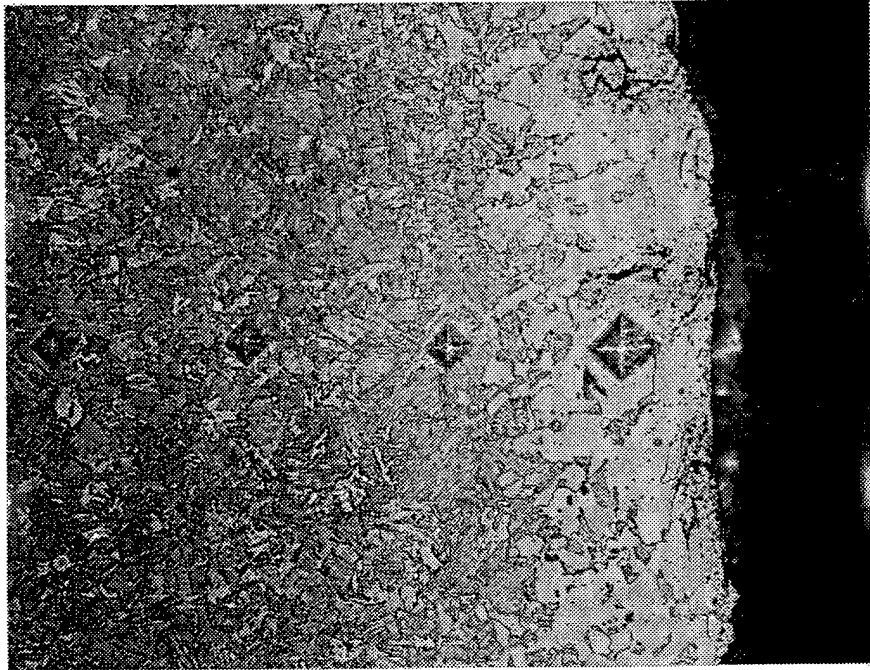

Figure 13. Vickers Microhardness Profile Along the Tip of a Thread From Setscrew U1 at Higher Magnification. (Note the larger indent within the decarburized layer indicating a softer material; magnification 500x.)

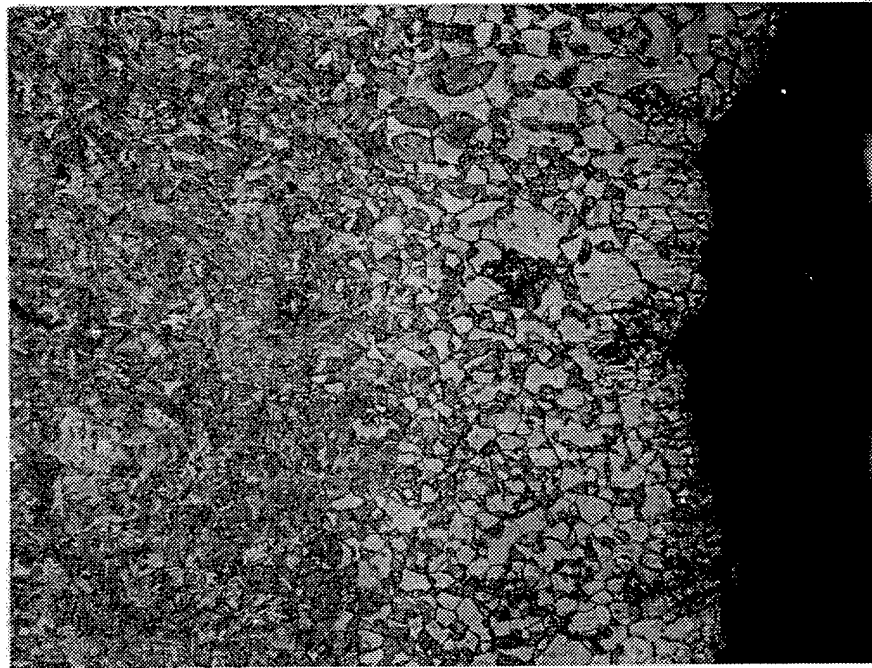

Figure 14. Vickers Microhardness Profile Along the Tip of a Thread From Setscrew N2 at Higher Magnification. (Note the larger indent within the decarburized layer indicating a softer material; magnification 500x.)

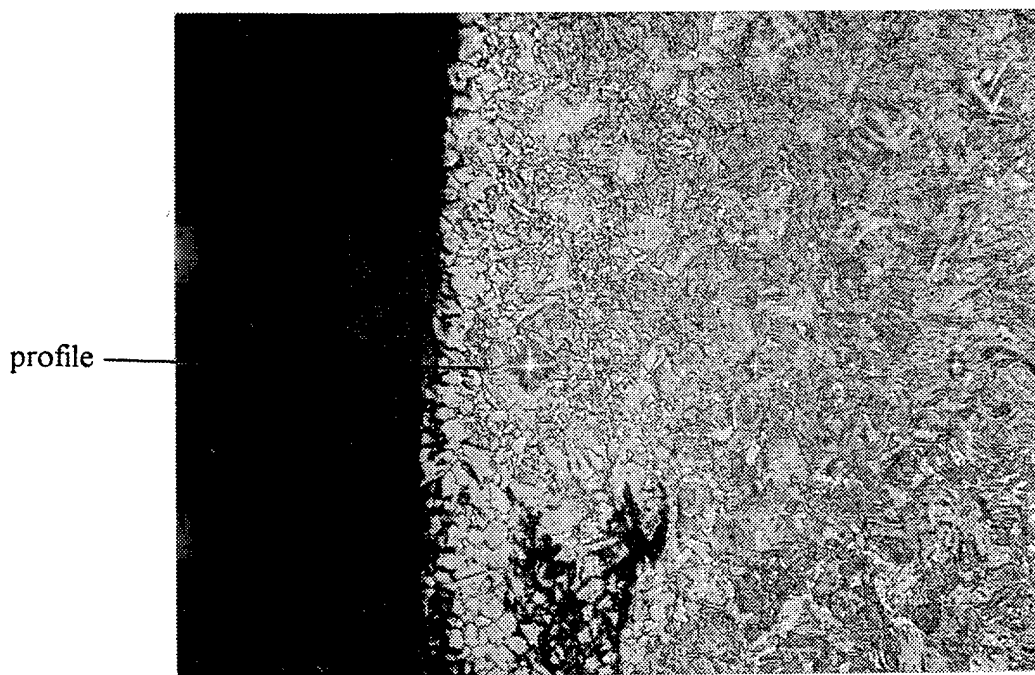

Figure 15. Vickers Microhardness Profile Along the Socket of Setscrew U1. (Note the larger indent within the decarburized layer indicating a softer material; magnification 500x.)

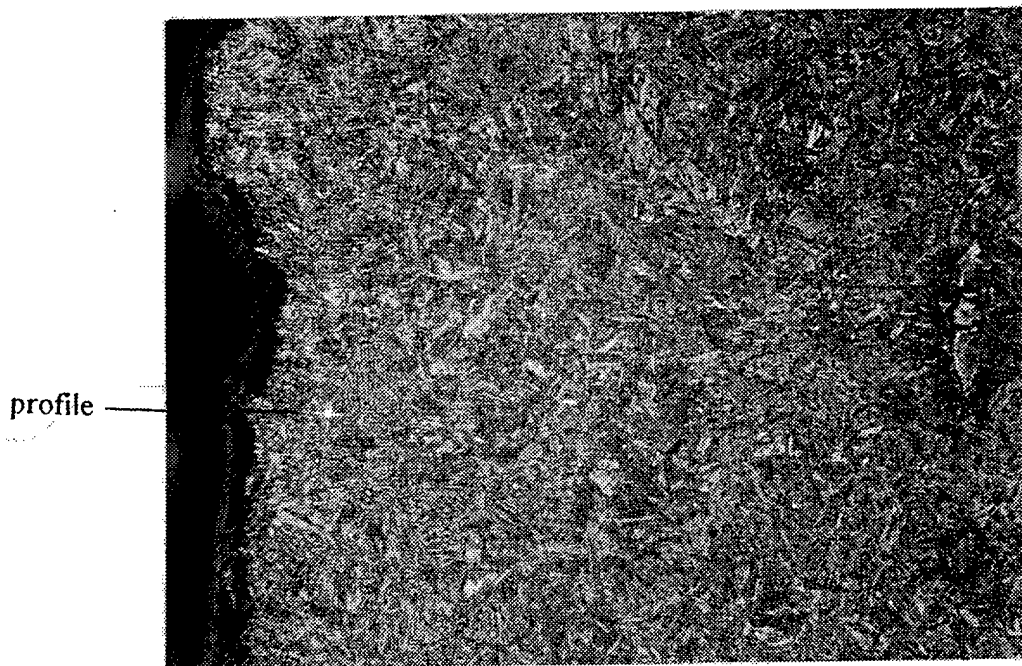

Figure 16. Vickers Microhardness Profile Along the Socket of Setscrew U4. (No decarburization was present on the socket surface; magnification 500x.)

profile

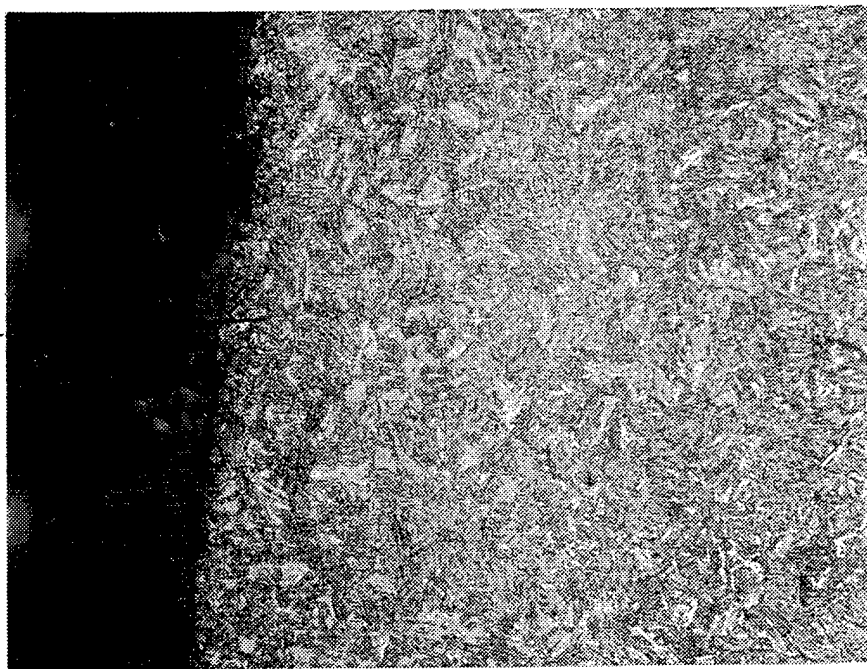

Figure 17. Vickers Microhardness Profile Along the Socket of Setscrew N1. (No decarburization was present on the socket surface; magnification 500x.)

profile

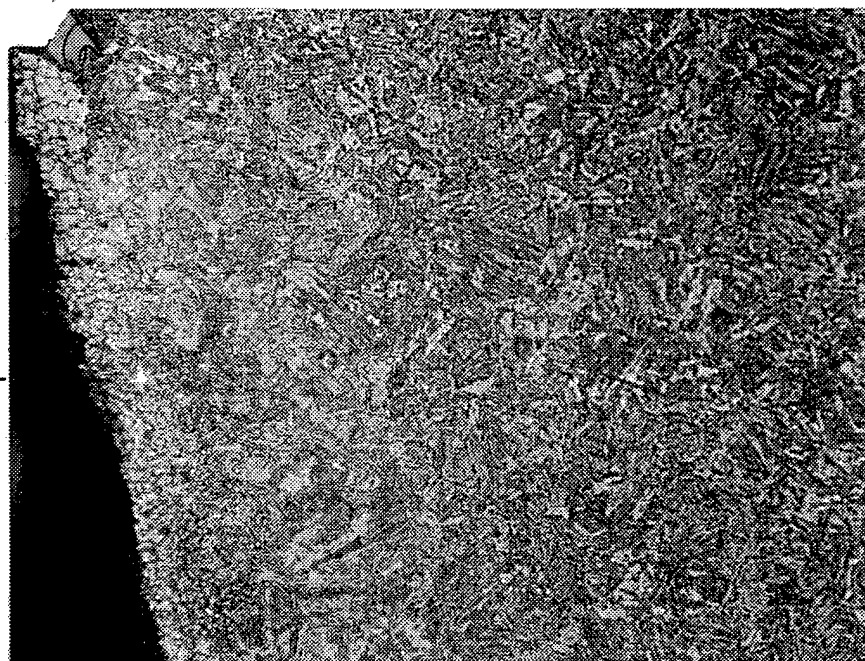

Figure 18. Vickers Microhardness Profile Along the Socket of Setscrew N2. (Note the larger indent within the decarburized layer indicating a softer material; magnification 500x.)

7. RECOMMENDED TORQUE

The recommended tightening torque of a cup-point setscrew with a 1/2-inch diameter and a hardness of 45 to 50 HRC is 620 in-lb. This was listed in the Design of Machine Elements Handbook (4th Edition, V. Faires, p. 177) and is used by major fastener companies. This torque level theoretically has a holding force of 3,000 pounds (assuming a bomb body hardness of 15 HRC). This holding force is much less for a bomb body with a higher hardness. The requirement of 40 in-lb on NAVAIRSYSCOM Drawing 2877751 seems quite conservative and should not account for plastic deformation of the setscrews.

8. DISCUSSION

Decarburization is a loss of carbon from the surface layer of a carbon-containing alloy because of a reaction with one or more chemical substances in a medium that contacts the surface.² Unless the manufacturer takes special precautions, there is always a risk of losing carbon from the surface of a steel while heating to high temperatures in an oxidizing atmosphere (such as air). The effect of decarburization has been shown to be greater for higher strength steels (such as the setscrews being investigated), rather than low strength steels. Decarburization was noted on the setscrews in various amounts. Although the decarburization noted met the depth requirement of FF-S-200, the decarburization was classified as "total." The presence of this layer lowered the surface hardness from the required 45 to 53 HRC to a hardness as low as 90 HRB (approximately), as determined through microhardness testing (see Table 4). This could lead to possible wear at all surfaces containing the decarburized layer and could have accounted for the fact that the three of the four used setscrews received displayed worn (stripped) sockets. The softer socket walls have less resistance to the hard tool placed inside for torquing purposes. In addition, a worn tool or a tool that was not properly mated could have increased the chances of a stripped socket.

9. CONCLUSIONS

Three of the four setscrews sectioned (one used and two new) exhibited some degree of decarburization, which was verified by both microhardness testing and metallography. The presence of total decarburization was not acceptable according to the governing specification. Although the depth of decarburization was within the governing limits, the presence of this soft

²ASM Metals Handbook, Ninth Edition, Volume 11, Failure Analysis and Prevention.

external layer most likely contributed to the worn sockets of the used setscrews. No significant trends between the properties of the used and new setscrews were noted.

10. RECOMMENDATIONS

The presence of any total decarburization is unacceptable, and measures should be taken by the manufacturer to alleviate this problem. Also, a square socket setscrew, rather than the hex-shaped socket, may provide a greater tolerance to stripping because of its geometry. In addition, care should be taken to ensure that worn tools are discarded, so as to reduce the chance of socket stripping. Also, automatic tools should only be used once the tool is engaged; a rotating bit placed into the socket increases the chances of stripping. Specified torque requirements should be obeyed. Automatic tools can be difficult to control and quite often result in over-torquing, which causes stripping of the socket.

11. FUTURE WORK

NAWC is attempting to find setscrews that cracked in service to send to ARL. This may prove difficult since cracking occurs once the setscrews are installed. The increase in size of the cracked setscrew makes extraction nearly impossible. If cracked setscrews are received, ARL will examine the fracture surfaces using light optical microscopy and scanning electron microscopy to determine the primary cause of failure.

INTENTIONALLY LEFT BLANK

<u>NO. OF COPIES</u>	<u>ORGANIZATION</u>
2	ADMINISTRATOR DEFENSE TECHNICAL INFO CENTER ATTN DTIC DDA 8725 JOHN J KINGMAN RD STE 0944 FT BELVOIR VA 22060-6218
1	DIRECTOR US ARMY RESEARCH LABORATORY ATTN AMSRL CS AL TA RECORDS MANAGEMENT 2800 POWDER MILL RD ADELPHI MD 20783-1197
1	DIRECTOR US ARMY RESEARCH LABORATORY ATTN AMSRL CI LL TECHNICAL LIBRARY 2800 POWDER MILL RD ADELPHI MD 207830-1197
1	DIRECTOR US ARMY RESEARCH LABORATORY ATTN AMSRL CS AL TP TECH PUBLISHING BRANCH 2800 POWDER MILL RD ADELPHI MD 20783-1197
2	COMMANDER US ARMY MATERIEL COMMAND ATTN AMCSCI AMCQA P S J LORBER 5001 EISENHOWER AVENUE ALEXANDRIA VA 22333-0001
4	CDR HQ AMCCOM ATTN AMSMC PCA WM J WELLS AMSMC QAM I G SMITH AMSMC ASR M B KUNKEL J HOUSEMAN ROCK ISLAND IL 61299-6000
1	CDR US ARMY ARDEC ATTN SMCAR CCS C A SEBASTO BLDG 1 PICATINNY ARSENAL NJ 07806-5000
5	NAVAL AIR WARFARE CENTER ATTN STEVE KOHLER CODE 473310E POINT MUGU CA 93042-5000

<u>NO. OF COPIES</u>	<u>ORGANIZATION</u>
5	NAVAL AIR WARFARE CENTER ATTN FRED BECKER CODE 473310E POINT MUGU CA 93042-5000 <u>ABERDEEN PROVING GROUND</u>
2	DIRECTOR US ARMY RESEARCH LABORATORY ATTN AMSRL CI LP (TECH LIB) BLDG 305 APG AA
10	DIRECTOR US ARMY RESEARCH LABORATORY ATTN AMSRL WM MD (M PEPI) BLDG 4600

INTENTIONALLY LEFT BLANK

REPORT DOCUMENTATION PAGE

Form Approved
OMB No. 0704-0188

Public reporting burden for this collection of information is estimated to average 1 hour per response, including the time for reviewing instructions, searching existing data sources, gathering and maintaining the data needed, and completing and reviewing the collection of information. Send comments regarding this burden estimate or any other aspect of this collection of information, including suggestions for reducing this burden, to Washington Headquarters Services, Directorate for Information Operations and Reports, 1215 Jefferson Davis Highway, Suite 1204, Arlington, VA 22202-4302, and to the Office of Management and Budget, Paperwork Reduction Project (0704-0188), Washington, DC 20503.

1. AGENCY USE ONLY (Leave blank)		2. REPORT DATE November 1997	3. REPORT TYPE AND DATES COVERED Final	
4. TITLE AND SUBTITLE Examination of BSU-86/B Setscrews			5. FUNDING NUMBERS	
6. AUTHOR(S) Pepi, M.S. (ARL)				
7. PERFORMING ORGANIZATION NAME(S) AND ADDRESS(ES) U.S. Army Research Laboratory Weapons & Materials Research Directorate Aberdeen Proving Ground, MD 21010-5066			8. PERFORMING ORGANIZATION REPORT NUMBER	
9. SPONSORING/MONITORING AGENCY NAME(S) AND ADDRESS(ES) U.S. Army Research Laboratory Weapons & Materials Research Directorate Aberdeen Proving Ground, MD 21010-5066			10. SPONSORING/MONITORING AGENCY REPORT NUMBER ARL-MR-379	
11. SUPPLEMENTARY NOTES				
12a. DISTRIBUTION/AVAILABILITY STATEMENT Approved for public release; distribution is unlimited.			12b. DISTRIBUTION CODE	
13. ABSTRACT (Maximum 200 words) A total of four used and four new setscrews from a BSU-86/B bomb fin assembly were examined to determine the probable cause of internal socket head stripping. The intent was to compare the properties of the used setscrews to those of the new. The U.S. Army Research Laboratory (ARL), Weapons and Materials Research Directorate (WMRD), performed a dimensional verification to ensure that the parts undergoing investigation met the governing requirements. The wall thickness at the internal socket points was found to be less than nominal in most setscrews. The chemical composition of two used and two new bolts compared favorably to American Institute for Steel and Iron (AISI) 4037 steel, which was in accordance with the governing requirement. The core hardness of the parts fell within the required range. Vickers microhardness profiles from the surface of the parts showed that a gradient existed in one of the used and in one of the new setscrews. Metallography was subsequently used to determine the cause of the hardness gradients. A layer of total decarburization was revealed on most of the setscrews upon etching with 2% nital. Although the thickness of the layer met the requirements of FF-S-200, the presence of "total" decarburization was not in accordance with MIL-H-6875 for Class A material. The microstructure of each setscrew examined was finely tempered martensite, which conformed to an austenitized, quenched, and tempered part. It was concluded that no trends existed between the used and new setscrews examined. Recommendations were offered concerning the required torque, as well as the use of automatic tools.				
14. SUBJECT TERMS decarburization metallurgical examination hex socket setscrew			15. NUMBER OF PAGES 30	
			16. PRICE CODE	
17. SECURITY CLASSIFICATION OF REPORT Unclassified	18. SECURITY CLASSIFICATION OF THIS PAGE Unclassified	19. SECURITY CLASSIFICATION OF ABSTRACT Unclassified	20. LIMITATION OF ABSTRACT	