

ARMY RESEARCH LABORATORY



Rapid Assessment of Small Changes to Major Gun and Projectile Dynamic Parameters

by Thomas F. Erline
and Leo L. Fisher

ARL-TR-1508

September 1997

DUO QUALITY INSPECTED

19971119 119

Approved for public release; distribution is unlimited.

The findings in this report are not to be construed as an official Department of the Army position unless so designated by other authorized documents.

Citation of manufacturer's or trade names does not constitute an official endorsement or approval of the use thereof.

Destroy this report when it is no longer needed. Do not return it to the originator.

Army Research Laboratory

Aberdeen Proving Ground, MD 21005-5066

ARL-TR-1508

September 1997

Rapid Assessment of Small Changes to Major Gun and Projectile Dynamic Parameters

Thomas F. Erline

Weapons and Materials Research Directorate, ARL

Leo L. Fisher

United Defense, LP

Abstract

The U.S. Navy's 5-in 54-cal. (5"/54) gun system Mark (Mk) 45 was subjected to first-order dynamic analysis tools that allowed rapid assessment of ballistic dispersion of a typical naval high-explosive projectile.

The interior ballistics high-velocity gun version 2 (IBHVG2) modeled the 5-in propelling charge Mk 67, and gun barrel centerline data were obtained from two 5"/54 Mk 19 gun barrels. The "Little RASCAL" program was used to estimate the tipoff angles and angular rates for the Mk 64 5-in projectile, and the "PC-PRODAS" computer program was used to estimate the projectile yaw and yaw rates resulting from the bore and bourrelet clearance. The tipoff angles and rates obtained for the Little RASCAL program were then combined with the yaw data to establish a matrix of possible worst-case conditions of initial projectile yaw and yaw rate.

A total of 32 possible muzzle exit conditions were identified and used as initial conditions for a 6 degrees of freedom trajectory program. The resulting variation in range obtained from the 32 trajectory calculations was used to calculate the range probable error. The results obtained from this relatively simple analysis technique have shown very good correlation with ballistic dispersion measurements made during actual firing tests.

TABLE OF CONTENTS

	<u>Page</u>
LIST OF FIGURES	v
LIST OF TABLES	vii
1. INTRODUCTION	1
2. BACKGROUND	2
3. APPROACH	5
4. RESULTS	9
5. SUMMARY AND CONCLUSIONS	19
6. REFERENCES	23
DISTRIBUTION LIST	25
REPORT DOCUMENTATION PAGE	35

INTENTIONALLY LEFT BLANK.

LIST OF FIGURES

<u>Figure</u>	<u>Page</u>
1. Mk 64 5-in projectile	4
2. Gun system model	7
3. Gun barrel S/N 518 centerline data	7
4. Gun barrel S/N 17343 centerline data	8
5. Calculated and proving ground range dispersion	10
6. Achieved range differential of gun barrels S/Ns 518 and 17343	12
7. Dynamic shape of barrel S/N 518 during firing	16
8. Dynamic shape of barrel S/N 17343 during firing	16
9. Transverse velocity of gun muzzle (S/N 518) using base and softer spring constants of forward bourrelet	17
10. Transverse velocity of gun muzzle (S/N 518) using base and harder spring constants of forward bourrelet	17
11. Transverse velocity of gun muzzle (S/N 17343) using base and softer spring constants of forward bourrelet	18
12. Transverse velocity of gun muzzle (S/N 17343) using base and harder spring constants of forward bourrelet	18
13. Effect of variations in forward bourrelet spring constant	20
14. Effect of variations in aft bourrelet spring constant	20

INTENTIONALLY LEFT BLANK.

LIST OF TABLES

<u>Table</u>		<u>Page</u>
1.	Projectile Mass Properties	4
2.	System Parameters Varied During Analysis	13
3.	Gun-Mount Parameter Variation Results	14
4.	Projectile Parameter Variation Results	15

INTENTIONALLY LEFT BLANK.

1. INTRODUCTION

The high cost of prototype fabrication and testing of today's complex weapon systems has placed an increasing emphasis on simulation and modeling to evaluate system design alternatives and effectiveness prior to actual hardware manufacture. In the area of large-caliber gun systems, some of the most expensive tests are those required to determine the ballistic dispersion of the gun and/or its ammunition. Although there are several very sophisticated computer models available today that will accurately predict the dynamic response of large-caliber gun systems during firing, these models typically require precise three-dimensional models of the gun system configuration and its mass properties. Therefore, these models are not well suited to conducting the "sanity check" type evaluations often required to assess the impact of potential design alternatives and/or proposed design modifications in a timely manner.

In a joint government/industry collaboration, the U.S. Army Research Laboratory (ARL) and the Armament Systems Division of United Defense, LP have investigated the feasibility of utilizing the "Little RASCAL" (Erline, Kregel, and Pantano 1990) gun dynamics simulation program in conjunction with "standard" interior and exterior ballistic programs to provide a "desktop" analysis capability to evaluate the ballistic dispersion of intermediate-caliber gun systems. The gun system chosen for analysis in this study was the U.S. Navy's 5-in 54-cal. (5"/54) Mark (Mk) 45 gun mount. The Mk 45 is the main gun armament of the majority of current U.S. surface combatants and is slated to be upgraded in capability as part of the Naval Surface Fire Support (NSFS) program. Therefore, considerable interest exists in obtaining a more detailed understanding of the system-error budget.

The analysis procedure described in this report has been shown to yield reasonable estimates of the ballistic dispersion of an intermediate-caliber indirect-fire weapon, offers a relatively simple method for obtaining "first-order" estimates of the impact of proposed design changes to either the weapon or its ammunition, and can provide a useful tool for gun system designers to assess the potential impact of small changes to major parameters affecting gun and projectile dynamics.

2. BACKGROUND

This study was based on two ARL-developed computer models: the Interior Ballistics High-Velocity Guns version 2 (IBHVG2) (Anderson and Fickie 1987) program, the Little RASCAL gun dynamics program, plus the commercially available projectile design and analysis program PRODAS.*

IBHVG2 is a lumped-parameter, interior ballistics computer code. The code, which was developed at ARL, is an updated version of the classic Baer-Frankle interior ballistic code. IBHVG2 is used to calculate interior ballistic trajectories, including gas pressure, projectile displacement, and projectile velocity as a function of time. IBHVG2 was used to compute the interior ballistic cycle of the standard 5-in propelling charge Mk 67. The Mk 67 charge is designed to produce a nominal exit velocity of 2,650 ft/s (808 m/s) with a 70-lb (31.75 ks) projectile. The projectile velocity and breech pressure vs. time data computed by IBHVG2 were used as input to the Little RASCAL gun dynamics program.

The Little RASCAL is a comprehensive modeling code for predicting lateral gun dynamics and projectile dynamics. When fired, the bore-riding projectile undergoes a complex sequence of mechanical and gas dynamic interactions on its way out the barrel. The Little RASCAL gun and projectile dynamics program is capable of simulating the inertial loading conditions brought about by the projectile interacting with the barrel in a plane as it accelerates the length of a gun tube's unique centerline. Thus, in tracking the projectile interacting with the barrel, the initial launch conditions of the projectile at shot exit can be predicted. Projectile pitch and pitch rates, as well as muzzle motion, are calculated and available for use as input to the exterior ballistic programs.

The Little RASCAL gun and projectile dynamics program is a dynamic displacements code employing a direct structural dynamics analysis approach to the simulation of firing a projectile from a gun. Both the gun system and the projectile are modeled using a series of equally spaced

* PRODAS is a commercial multifunction ballistics program developed by ARROW Tech., Inc.

cylindrical elements. Nodes are centered and assigned equivalent mass and stiffness values based on standard engineering formulae. Inertial forces and flexural forces are calculated using this simplified description. Flexure at each node is approximated by a second-order finite difference method, which allows the bending forces to be computed. Transverse nodal accelerations caused by these forces are integrated with respect to time to obtain transverse nodal velocities and integrated again to obtain lateral node displacements. Loads induced by pressure effects, mounting conditions, breech center of gravity offset, and the projectile interaction forces with the barrel are accounted for in the Little RASCAL program. All forces are then integrated by a predictor-corrector technique stabilized by a numerically stiff ordinary differential equation solver (Kregel and Lortie 1973).

The gun system, which includes the breech, barrel, and two gun supports, and the projectile system are two separate models. They are accounted for individually, except for a variational algorithm that handles their interaction. The interaction of the projectile with the barrel occurs through contact points. The two contact points defined on the projectile are usually positioned where they occur geometrically. The two projectile contact point positions on the barrel are dynamic and change as the projectile traverses the bore. The gun system model and the projectile model are two separate, flexible entities with each projectile contact point requiring a user-defined spring constant. The spring constants serve to define the interface loads between the projectile model and the gun model.

The Little RASCAL program has proven that simple modeling techniques in which the primary components of a gun system are included can produce reasonably accurate results in a timely manner. The code is generic enough so that almost any gun system and projectile can be modeled in a simple manner. Gun dynamics predictions made by Little RASCAL of barrel motion have been shown to agree quite well with experimental results over a wide range of gun system size and type (Erline and Kregel 1988).

The PRODAS program is a multifaceted projectile analysis package. The principal features of the program used for this study were the muzzle exit analysis feature and the six degree-of-freedom (6DOF) trajectory model. The muzzle exit segment of PRODAS was used to compute the initial

muzzle exit tipoff angle and tipoff rate resulting from the clearance between the projectile and the bore of the gun. The 6DOF trajectory model was used to determine the effect on achieved range of various initial pitch and yaw angles and angular rates.

The projectile geometry and mass properties used throughout the study were based on the standard 5-in Mk 64 projectile body (Figure 1) with high-explosive load and Mk 73 CVT proximity fuze. The mass properties of the projectile are summarized in Table 1.

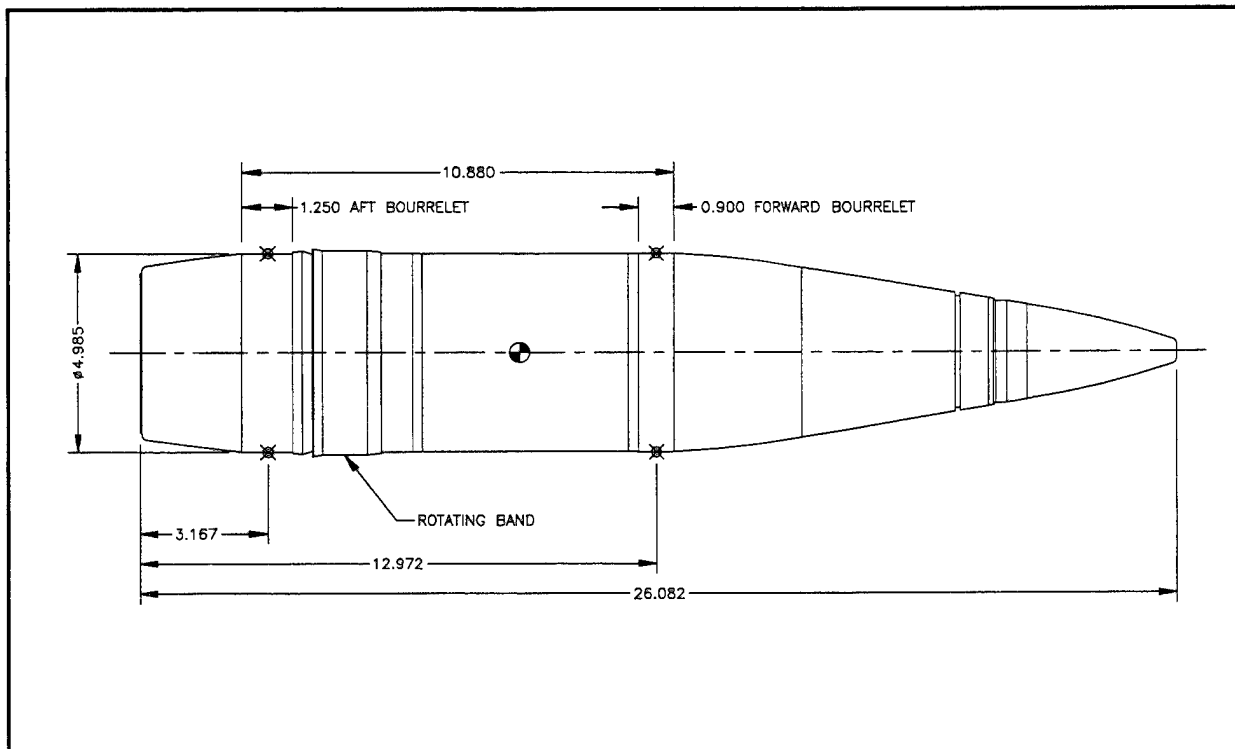

Figure 1. Mk 64 5-in projectile.

Table 1. Projectile Mass Properties

Weight	68.49 lb	(31.07 kg)
Center of Gravity From Nose	16.56 in	(420.6 mm)
Axial Moment of Inertia	240.83 lbm-in ²	(16.97 kg-m ²)
Transverse Moment of Inertia	2803.50 lbm-in ²	(2299.71 kg-m ²)

As with any gun dynamics model, the accuracy of the results obtained from the Little RASCAL model is dependent upon detailed, precise knowledge of the weapon being analyzed. Since the Mk 45 gun mount has been in production for over 20 years, a considerable volume of detailed information concerning the geometry, mass properties, and stiffness of various system components was available to facilitate the modeling process. This was also true for the ammunition components. The single area where detailed information did not exist was the gun barrel. Although dimensional and mass property data existed for the 5-in gun barrel Mk 19, there was little, if any, information on the centerline variations existent in previously manufactured gun barrels. To overcome this lack of information, centerline measurements of two Mk 19 Mod 2 gun barrels, serial numbers (S/N) 518 and 17343, were made by the ARL author using laser measuring equipment. A third gun barrel, S/N 17423, was also measured; however, data from this barrel became available too late to be included in this study.

The original objective of this study was to determine the ability of the Little RASCAL program to accurately predict the dynamic response of the Mk 45 gun mount during firing for the purpose of gaining a greater understanding of the total error budget of the system. However, as the analysis proceeded, it became apparent that the analysis methodology being employed could be utilized as a relatively simple means of assessing the potential impact of changes to certain key system design parameters upon the ballistic dispersion of the system.

3. APPROACH

The analysis methodology developed during this study involves a four-step process: (1) The Little RASCAL model is used to predict the projectile pitch and yaw angles and angular rates resulting from the dynamic response of the system during firing; (2) The tip off angle and angular rate resulting from the in-bore yaw of the projectile are computed for both nominal and maximum projectile-clearance conditions. These muzzle exit conditions are combined numerically with the Little RASCAL results to obtain a set of initial projectile launch conditions to be used with the 6DOF trajectory model; (3) The 6DOF trajectory model is used to compute the range to impact for each of the initial conditions defined in step 2; (4) The results of the trajectory calculations are

tabulated, and the mean and standard deviation of the achieved range are computed to give an estimate of the ballistic dispersion that would result from the system configuration being modeled.

The Little RASCAL modeling process involves describing the projectile, projectile interior ballistics, and the gun system. The projectile is described by its geometry and mass properties, plus a definition of the location and spring constant for each of the two contact points between the projectile and the gun barrel. The interior ballistics information consists of the projectile velocity vs. time history for the in-bore cycle. The gun system information required includes the geometry and mass description of the gun barrel and breech along with breech center of gravity offsets, if any, trunnion and elevation support locations, and their equivalent spring constants. The final gun system data requirement is the data describing the variations in the centerline of the gun barrel.

A simplified schematic representation of the gun system, as modeled in the Little RASCAL program, is shown in Figure 2. The breech assembly of the Mk 45 has a weight of 2,344 lb (1,063 kg), and its center of gravity is offset 0.141 in (3.58 mm) vertically and 0.0302 in (0.77 mm) horizontally. The trunnion supports are located 19 in forward of the rear face of the breech assembly and were assigned a spring constant of 3,200,000 lb/in (57.15×10^6 kg/m). The effective elevation support of the gun assembly is located 17 in aft of the trunnion and was assigned a spring constant of 135,800 lb/in (2.44×10^6 kg/m). As previously stated, the centerline variations of two 5-in Mk 19 Mod 2 gun barrels, S/N 518 and S/N 17343, were measured by ARL personnel for use during this study. The vertical and horizontal centerline deviations of the two barrels are shown in Figures 3 and 4.

The muzzle exit conditions computed by the PRODAS program include the magnitude of the tipoff angle and tipoff rate resulting from the bore to bourrelet clearance and spin of the projectile. The dimensional tolerances on the bourrelet of the projectile and the bore of gun barrel were examined to define the extreme clearance conditions likely to occur in fielded systems and the tipoff angle and angular rates for minimum and maximum clearance conditions computed. Since the orientation of these exit conditions (i.e., up, down, left, right, etc.) is random in nature, a baseline

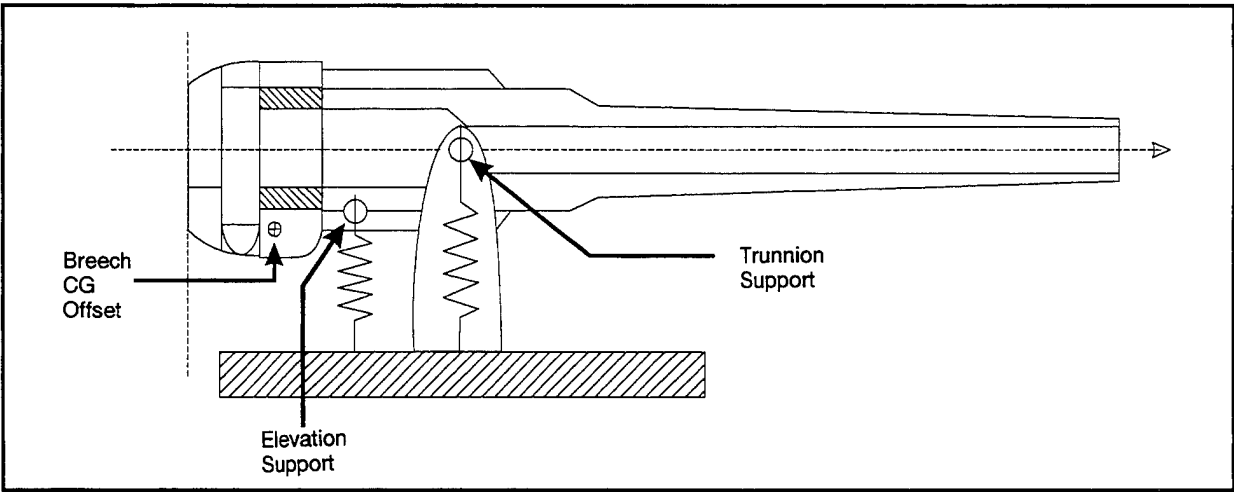

Figure 2. Gun system model.

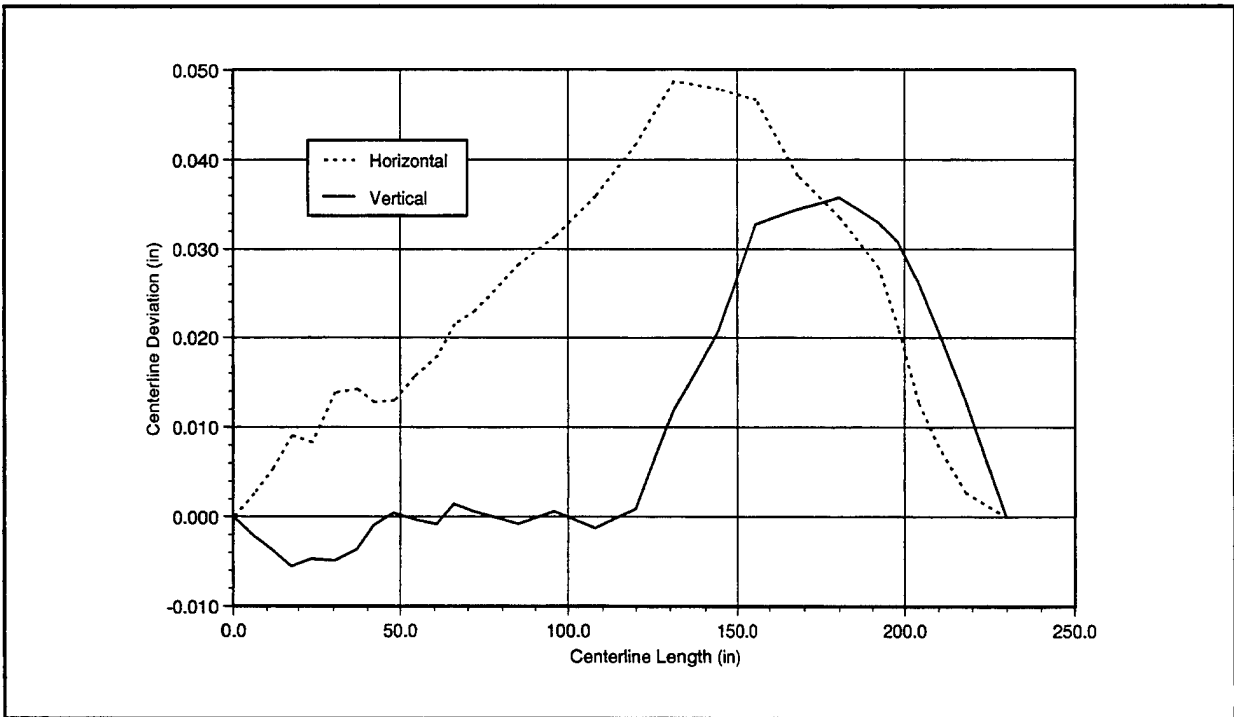

Figure 3. Gun barrel S/N 518 centerline data.

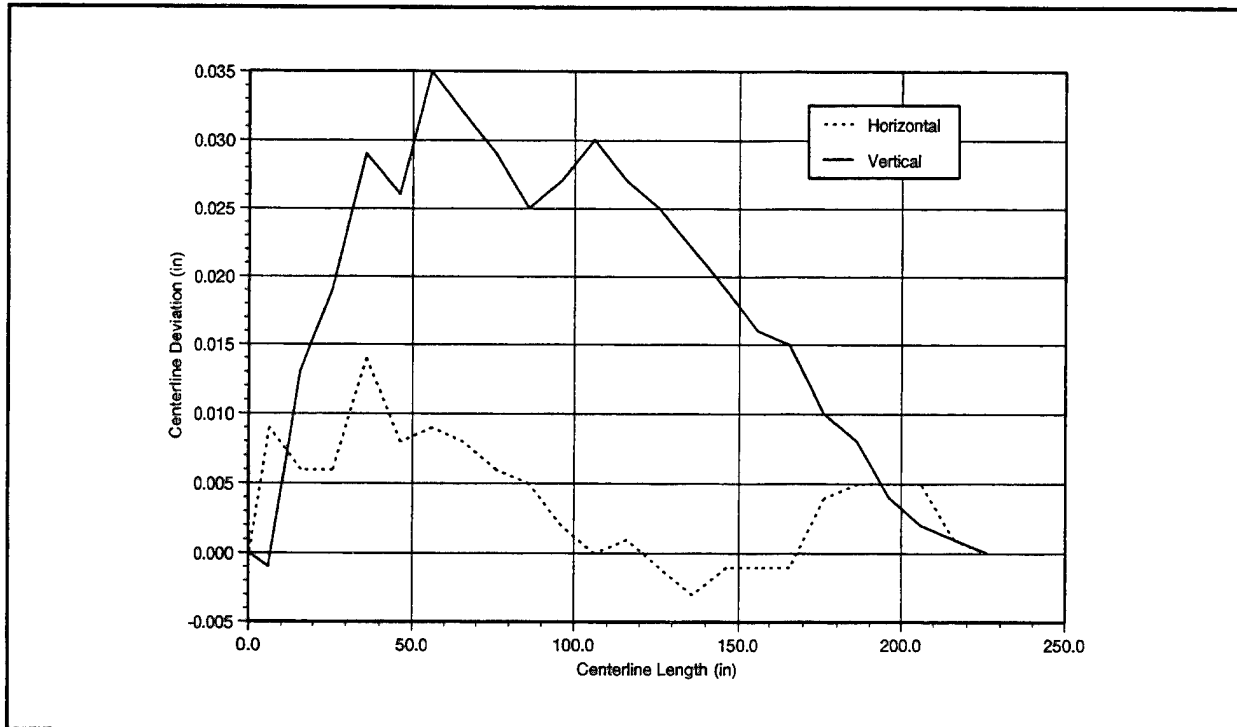

Figure 4. Gun barrel S/N 17343 centerline data.

analysis. These combinations of pitch and yaw angle and angular rate were combined numerically with the results from the Little RASCAL program to produce a matrix of initial launch conditions for the 6DOF trajectory model. Thus, a total of 64 possible launch conditions was established for each case to be analyzed.

Prior to beginning the analysis, the 6DOF trajectory model was “calibrated” by adjusting the projectile input data to obtain range results under standard conditions that corresponded to published information (Naval Sea Systems Command 1985) on the range performance of the 5"/54 gun system. Once the trajectory model was calibrated, the launch condition matrices were used to generate input data files for the trajectory model. Computation time for the test case trajectories varied between 2 and 20 min, depending on the gun elevation being used and the speed of the individual computer.

To facilitate analysis and manipulation of the data, the trajectory results were compiled in a computer spreadsheet. This approach permitted rapid computation of various statistical data such as the mean and standard deviation of the range results and plotting of the data.

4. RESULTS

The initial series of simulations performed using the Little RASCAL model consisted of determining the dynamic response of each gun barrel at seven different gun elevation angles. The elevation angles chosen corresponded to nominal gun ranges of 1,000 (914 m); 2,000 (1,828 m); 5,000 (4,572 m); 7,500 (5,212 m); 10,000 (9,140 m); 15,000 (13,716 m); and 20,000 (18,280 m) yd.

The results obtained from this initial modeling of the Mk 45's dynamic response at various elevation angles were used to assess the ability of methodology established for this study to provide a reasonable estimate of the ballistic dispersion that result from actual gun firings. Trajectory calculations were made using the results from both barrel centerlines at each evaluation angle. The range standard deviation obtained in each case was then compared to the best available estimates (Updike 1996) of actual gun system performance under proving ground conditions. The results of this assessment are shown in Figure 5.

The proving ground range dispersion values shown in Figure 5 are based on post-test analysis of a large volume of firing data collected by the Naval Surface Warfare Center/Dahlgren Division over the last 20+ years from numerous 5"/54 gun systems under various firing conditions. These values are derived during the post-test data reduction process and may be characterized as the standard deviation of the residual uncertainty that exists between the observed range of each around and the value computed when all known conditions (i.e., meteorological conditions, projectile weight, actual muzzle velocity, etc.) are factored into the standard 5"/54 fire-control equations. It has also been noted that observed ballistic dispersion of the 5"/54 gun system has been declining in recent years. This is evident in the results of a recent shipboard ammunition effectiveness test (Jones and Updike 1995) conducted under closely controlled conditions at a gun target range of approximately 18,000 yd; the observed standard deviation error in range was 48 yd (12 yd less than

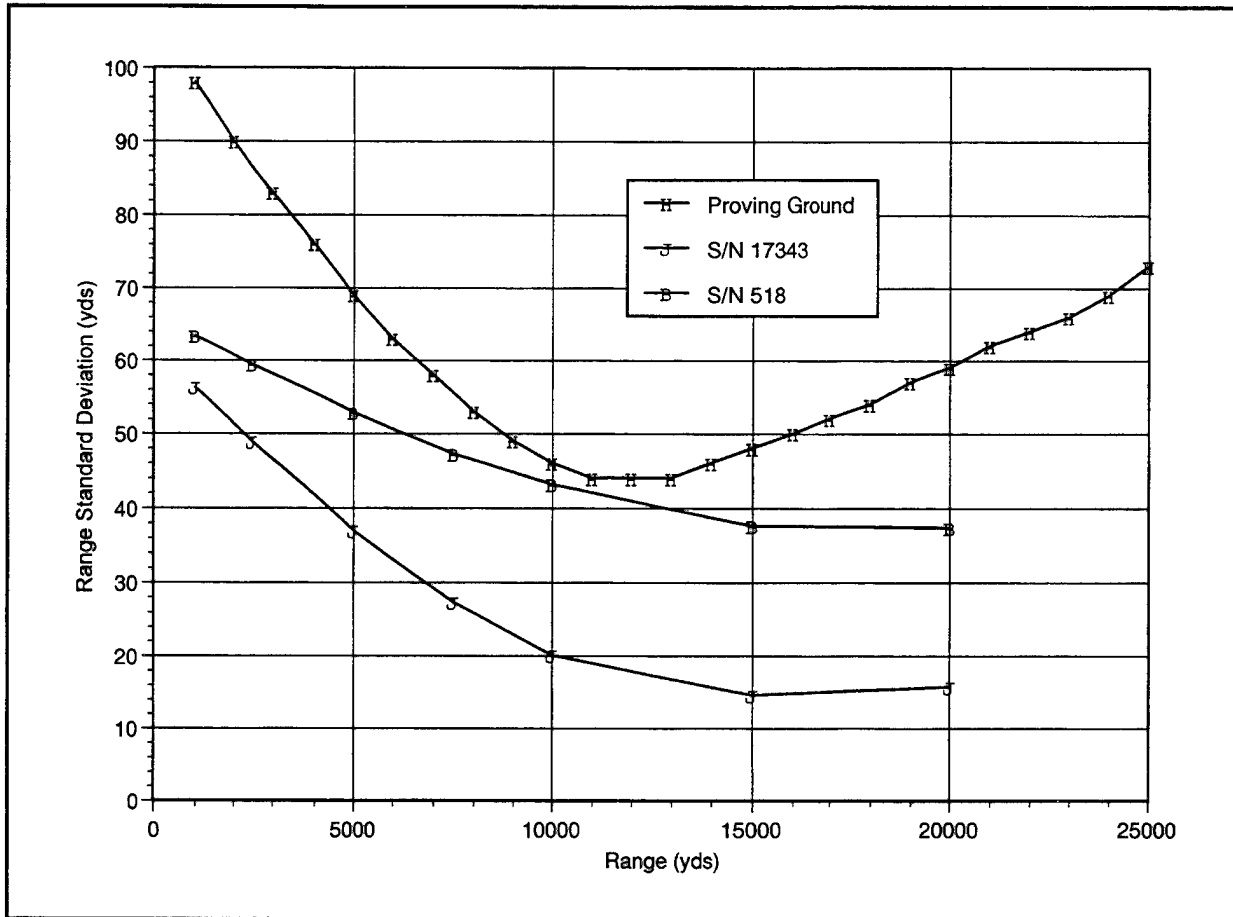

Figure 5. Calculated and proving ground range dispersion.

the established proving ground value). While the reasons for this decline in dispersion are beyond the scope of this report, a major contributing factor could be the improvements in dimensional consistency achieved in projectile bodies manufactured using numerically controlled machining processes.

The distinctive “U,” or “bathtub,” shape of the proving ground range dispersion curve is characteristic of most naval gun systems. Because naval guns employ a single service charge for both direct- and indirect-fire targets, variations in the departure angle of the projectile tend to be the dominate cause of range dispersion at short range, while factors that affect the drag and flight characteristics of the projectile (i.e., dimensional variations, surface finish, center-of-gravity location,

inertia, etc.) are the dominate source of error at long range. In addition, transient meteorological effects have a greater impact on the long-range trajectories.

A further detail that must be considered when interpreting the results illustrated in Figure 5 is the effect on the projectile initial tipoff angle and angular rate caused by the torsional response of the gun barrel due to the rifling reaction as the projectile is spun up during the ballistic cycle. This response is not modeled in the Little RASCAL program and could account for the underprediction of dispersion at the shorter ranges.

In light of the considerations discussed previously and the limited amount of barrel centerline data available, it was concluded that the analysis methodology developed for this study was providing a reasonably (accurate first-order indication of range dispersion resulting from the dynamic response of the gun). In addition, further analysis of the trajectory results revealed that the average achieved range of rounds fired from gun barrel S/N 518 was always less than that achieved by gun barrel S/N 17343 as illustrated in Figure 6.

While it has frequently been observed that some guns are “long shooters” while others are “short shooters” and that retubing can change a gun from a long shooter to a short shooter and vice versa, the cause of this phenomenon has never been adequately explained or investigated. Although the limited sample size used in this study precludes any definitive conclusions concerning the cause of this phenomenon, the authors feel that further investigation of the effect of gun barrel centerline variations on average achieved range could lead to a more thorough understanding.

Encouraged by these initial results, the authors set out to determine if the analysis technique could be used to characterize the effect on ballistic dispersion of changes to major system design parameters. The system parameters chosen for further analysis were the effective spring constants of the gun trunnions, the elevation support structure, and the forward and aft bourrelets of the projectile body. Since design changes to both the trunnions and elevation drive of the Mk 45 gun

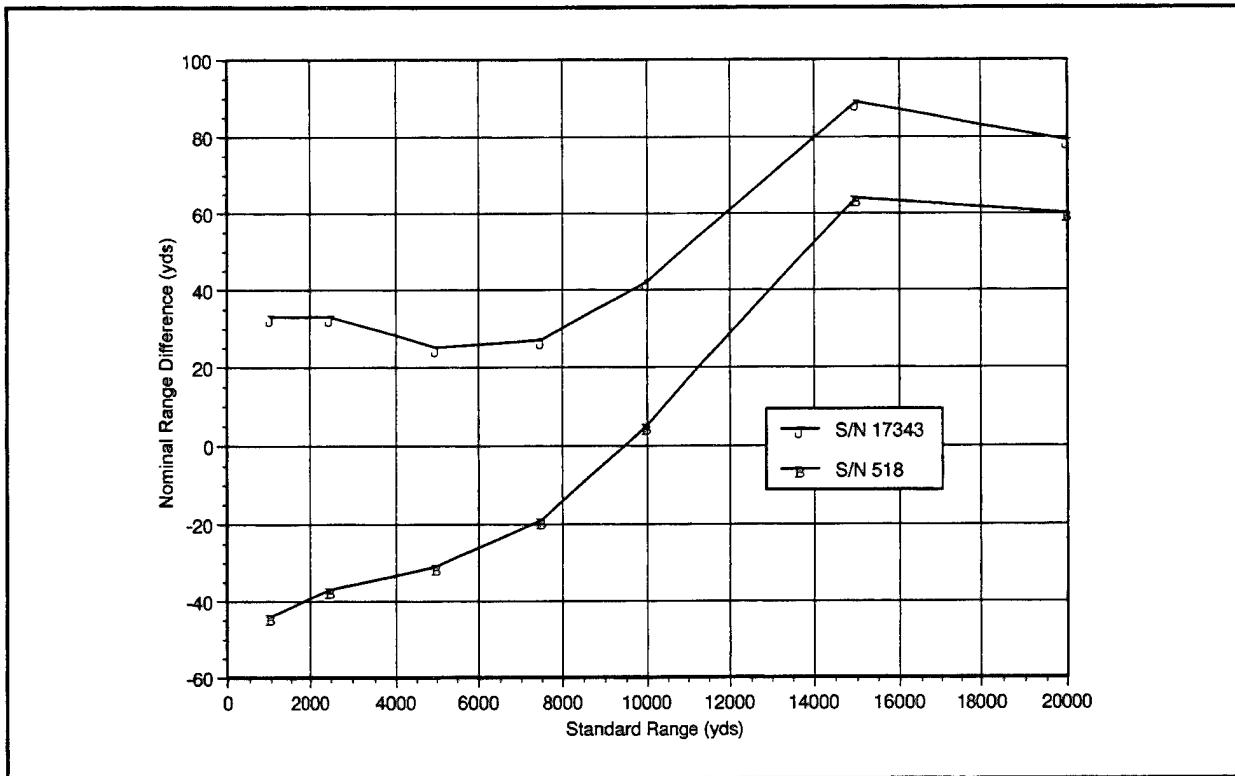

Figure 6. Achieved range differential of gun barrels S/Ns 518 and 17343.

mount are currently being considered as part of the Naval Surface Fire Support upgrade package, the potential impact of changes in these components on ballistic dispersion was of particular interest. Although the significance of accurate estimates of projectile body spring constants on Little RASCAL analysis results has been previously investigated (Erline 1991), the impact of changes or variations in these physical characteristics of the projectile upon the ballistic dispersion of indirect-fire weapons has not been explored.

To assess the utility of the analysis methodology in the characterization of the sensitivity of system ballistic dispersion to variations in the identified system parameters, additional calculations were conducted using the range of values shown in Table 2. Each parameter was varied over the range of values while all the others were held constant at the baseline values previously established for the system. Separate calculations were conducted for each of the two gun barrel centerlines.

Table 2. System Parameters Varied During Analysis

Parameter	Spring Constant lb/in (kg/m)				
	Lower Values		Baseline	Higher Values	
Trunnions	1.92e+6 (34.29e+6)	2.24e+6 (40.06e+6)	2.72e+6 (48.57e+6)	3.20e+6 (57.15e+6)	—
Elevation Support	109,440 (1.95e+6)	123,120 (2.20e+6)	135,800 (2.43e+6)	150,480 (2.69e+6)	164,160 (2.93e+6)
Fwd Bourrelet	0.5e+6 (8.93e+6)	0.8e+6 (14.29e+6)	1.18e+6 (21.07e+6)	2.0e+6 (35.72e+6)	3.0e+6 (53.57e+6)
Aft Bourrelet	0.5e+6 (8.93e+6)	0.8e+6 (14.29e+6)	1.08e+6 (19.28e+6)	2.0e+6 (35.72e+6)	3.0e+6 (53.57e+6)

The range of values chosen for the trunnions and the elevation support was based on engineering experience and the results of numerous shock and vibration analyses and tests that have been conducted on the Mk 45 gun mount since its introduction to the fleet in the early 1970s. The range of spring constants for the projectile bourrelets was based on test results from two Mk 64 projectile bodies and data collected by ARL on the radial stiffness of 120-mm tank projectiles (Lyon 1994). The results obtained from the Little RASCAL model for the variations of the gun mount parameters are shown in Table 3, and the results for variations of the projectile parameters are shown in Table 4.

The small changes in projectile initial conditions that resulted from rather large changes in the spring constants of the gun trunnions and elevation support would seem to indicate that the ballistic dispersion of the Mk 45 gun system is relatively insensitive to major changes in these parameters.

The changes in the initial projectile pitch and yaw angles and angular rates resulting from the changes in the spring constants of both the forward and aft bourrelets are shown in Table 4.

The dynamic shape of the two gun barrels during firing with the baseline initial conditions is shown in Figures 7 and 8. Each figure illustrates the shape of the barrel when the projectile has

Table 3. Gun Mount Parameter Variation Results

Parameter	Barrel S/N	Support Stiffness (lb/in)	Pitch Angle (rad)	Yaw Angle (rad)	Pitch Rate (r/s)	Yaw Rate (r/s)
Elevation Support	518	164,160	6.9920e-04	6.7707e-04	1.7406	0.4797
		150,480	6.9905e-04	6.7707e-04	1.7405	0.4798
		135,800	6.9871e-04	6.7707e-04	1.7404	0.4798
		123,120	6.9876e-04	6.7707e-04	1.7403	0.4798
		109,440	6.9816e-04	6.7707e-04	1.7402	0.4798
	17343	164,160	-7.7922e-04	4.9129e-04	-0.8651	1.5032
		150,480	-7.7956e-04	4.9129e-04	-0.8656	1.5032
		135,800	-7.7990e-04	4.9130e-04	-0.8661	1.5032
		123,120	-7.8023e-04	4.9131e-04	-0.8666	1.5032
		109,440	-7.8058e-04	4.9131e-04	-0.8671	1.5032
Trunnions	518	3,200,000	6.9871e-04	6.7707e-04	1.7404	0.4798
		2,720,000	7.0022e-04	6.7708e-04	1.7412	0.4798
		2,240,000	7.0154e-04	6.7709e-04	1.7419	0.4798
		1,920,000	7.0241e-04	6.7709e-04	1.7423	0.4798
	17343	3,200,000	-7.7990e-04	4.9130e-04	-0.8661	1.5032
		2,720,000	-7.7990e-04	4.9132e-04	-0.8662	1.5032
		2,240,000	-7.7992e-04	4.9133e-04	-0.8663	1.5032
		1,920,000	-7.7991e-04	4.9134e-04	-0.8663	1.5032

traveled three-fourths of the distance to the muzzle, seven-eighths of the distance to the muzzle, and at muzzle exit. The reference for gun barrel motion in these figures is as follows: at time zero all nodal displacements are zero. The dynamic response of the two gun barrels is unique to their individual centerline variations, as shown in Figures 7 and 8. These unique reaction characteristics are also evident in the transverse velocity of the gun muzzle during the in-bore cycle. As can be seen in Figures 9–12, the frequency and amplitude of the transverse velocity response shift with changes in the spring constant of the forward bourrelet of the projectile. This frequency shift is due to a change in the projectile’s rigid-body rocking modes. Since there are two rocking modes (Thomson 1981), changing the spring constants of projectile bourrelets changes the response of the gun barrel.

Table 4. Projectile Parameter Variation Results

Parameter	Barrel S/N	Support Stiffness (lb/in)	Pitch Angle (rad)	Yaw Angle (rad)	Pitch Rate (r/s)	Yaw Rate (r/s)
Fwd Bourrelet	518	3,000,000	1.7604e-04	3.6752e-03	-4.4191	1.5883
		2,000,000	1.2332e-03	3.7083e-03	-1.4797	6.1585
		1,185,000	6.9871e-04	6.7707e-04	1.7404	0.4798
		800,000	-4.0800e-04	1.3737e-03	-0.3266	-1.6183
		500,000	-2.8924e-04	1.9709e-03	-3.3228	-0.5196
	17343	3,000,000	1.7451e-03	2.7548e-04	-0.5799	3.4469
		2,000,000	1.5485e-03	2.0303e-03	3.9567	0.1358
		1,185,000	-7.7990e-04	4.9130e-04	-0.8661	1.5032
		800,000	5.5708e-04	1.3142e-03	-0.0378	-1.8546
		500,000	1.3455e-04	1.8419e-04	1.5311	0.2972
Aft Bourrelet	518	3,000,000	1.0206e-04	7.6987e-04	1.0323	4.1891
		2,000,000	8.3561e-04	5.9081e-04	2.1809	1.0394
		1,085,000	6.9871e-04	6.7707e-04	1.7404	0.4798
		800,000	4.7562e-04	9.9157e-04	1.8221	-0.7687
		500,000	8.1551e-05	1.5270e-04	1.5868	-0.1344
	17343	3,000,000	-6.9767e-04	9.4122e-04	0.6385	2.2155
		2,000,000	-7.2585e-04	8.1648e-04	-0.3713	3.4534
		1,085,000	-7.7990e-04	4.9130e-04	-0.8661	0.4798
		800,000	-6.4252e-04	5.0799e-04	-1.2817	0.2990
		500,000	3.4813e-04	2.1200e-03	0.8365	1.6513

From all of the results generated during this study, it was noted that the changes in the spring constant of the forward bourrelet produced much larger changes in the dynamic response of the system than changes to the spring constant of the aft bourrelet. The dominant influence of the forward bourrelet results from several factors, the most obvious being that the forward bourrelet is the first point on the projectile body to encounter the variations in the barrel, and that the center of gravity of the projectile is closer to the forward bourrelet.

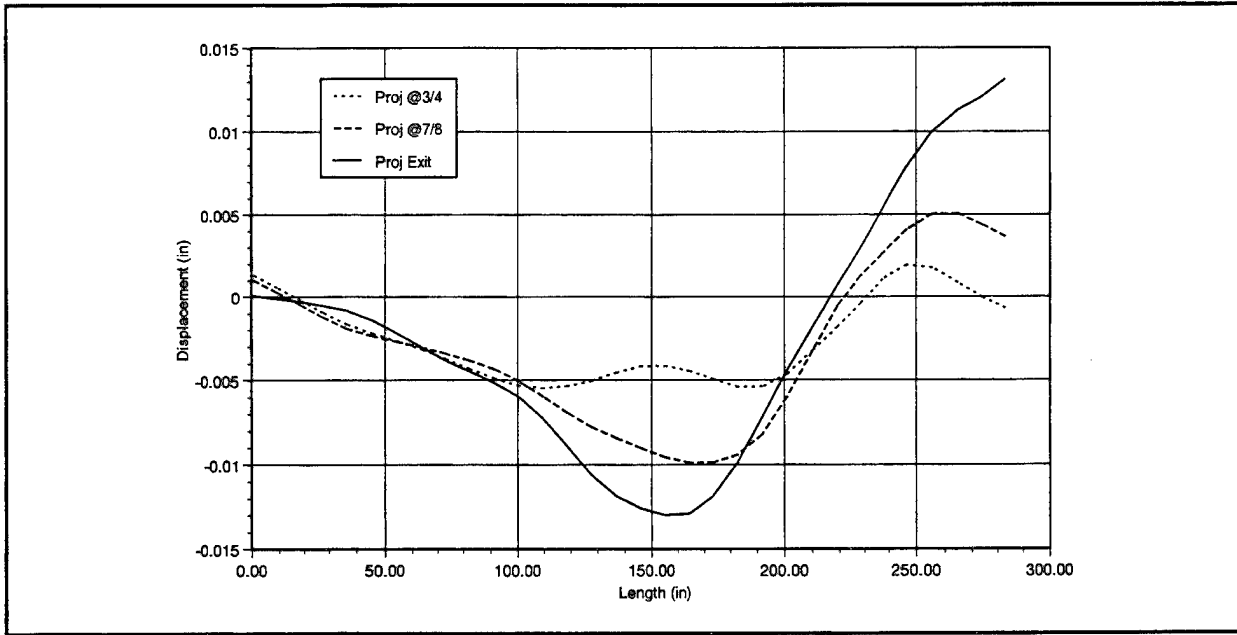

Figure 7. Dynamic shape of barrel S/N 518 during firing.

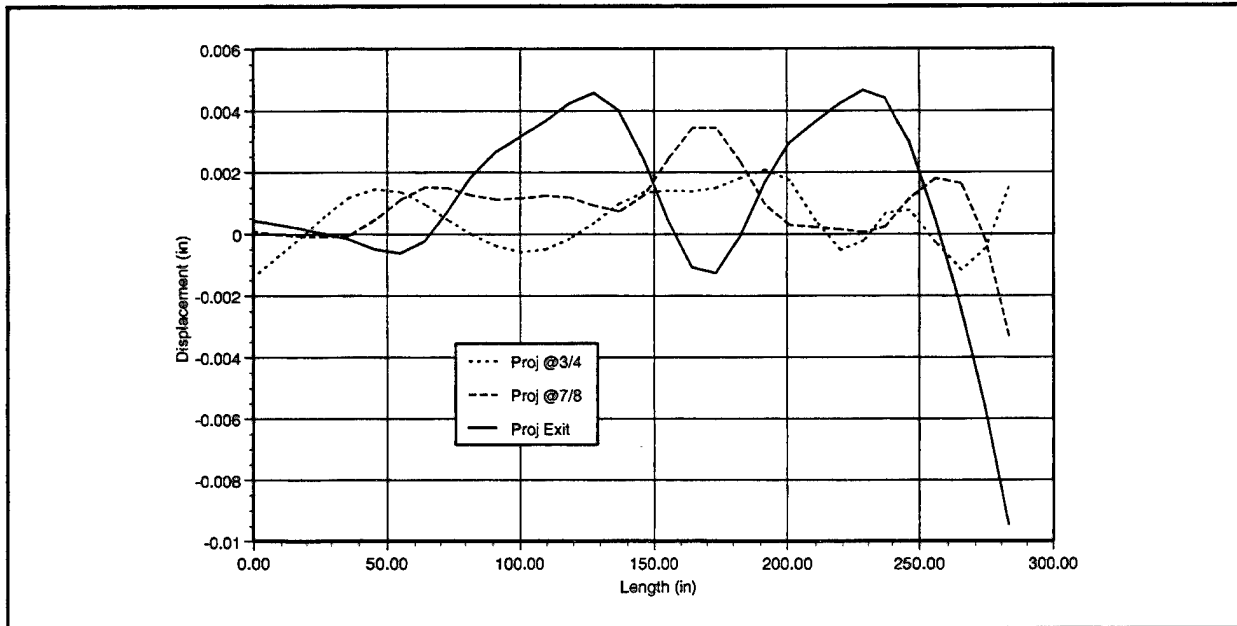

Figure 8. Dynamic shape of barrel S/N 17343 during firing.

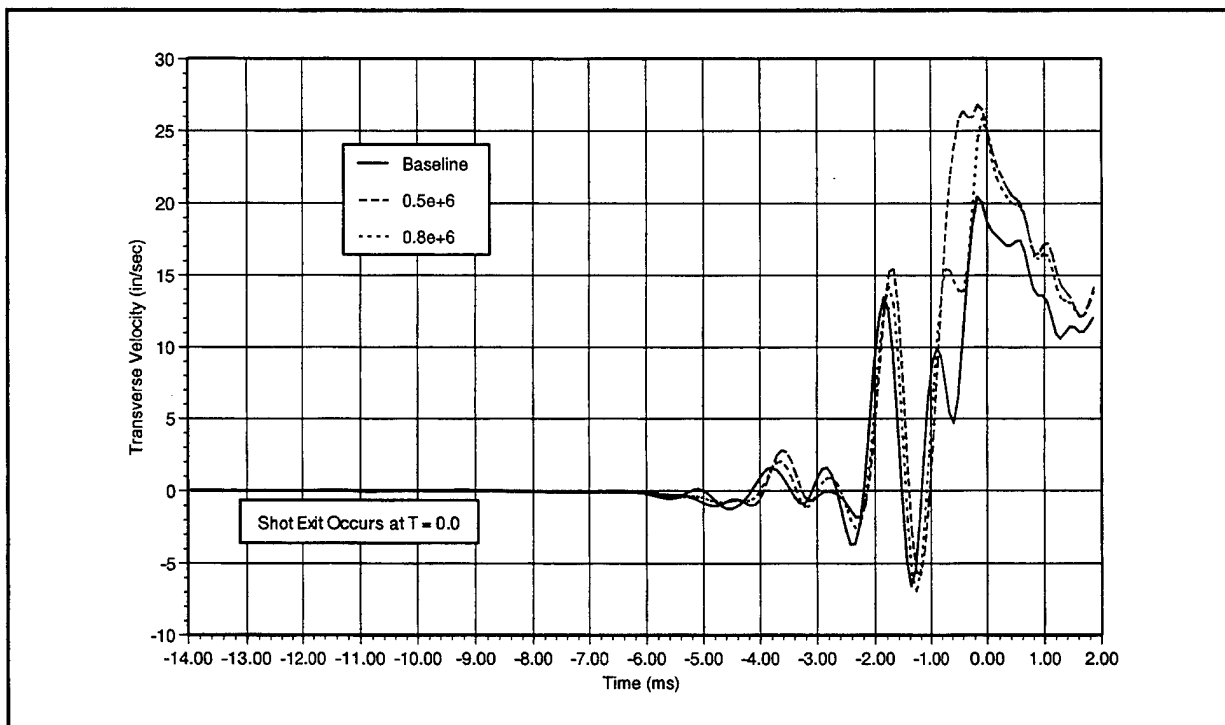

Figure 9. Transverse velocity of gun muzzle (S/N 518) using base and softer spring constants of forward bourrelet.

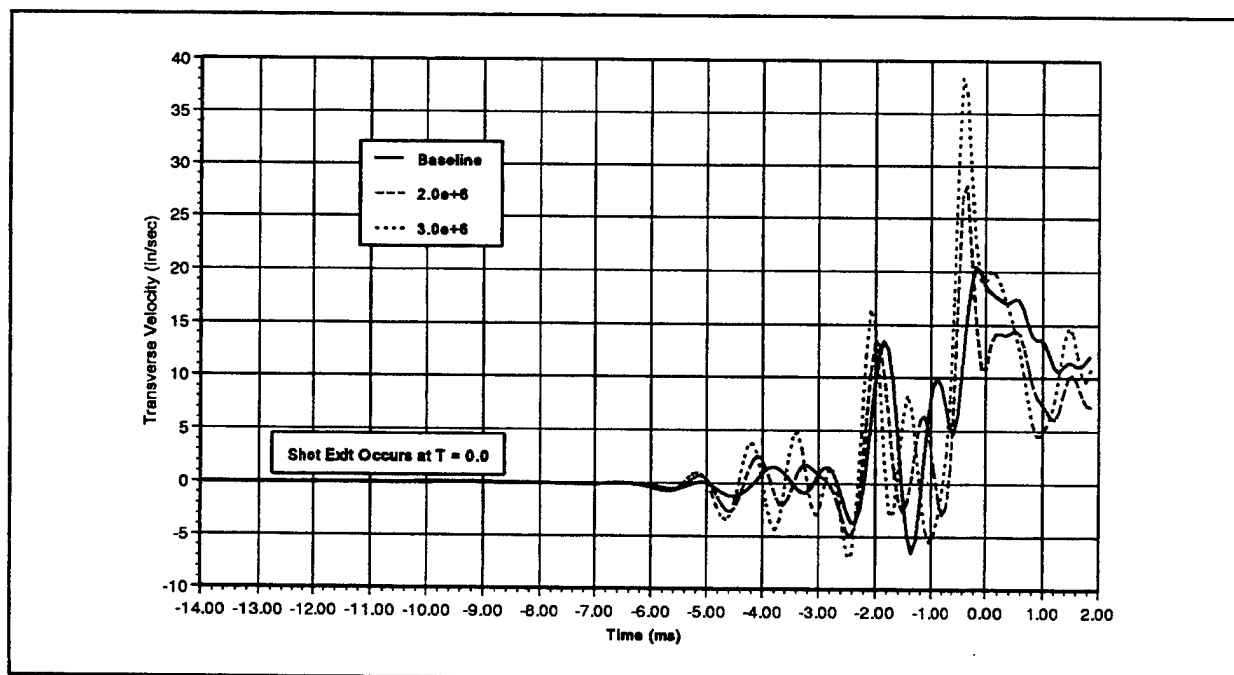

Figure 10. Transverse velocity of gun muzzle (S/N 518) using base and harder spring constants of forward bourrelet.

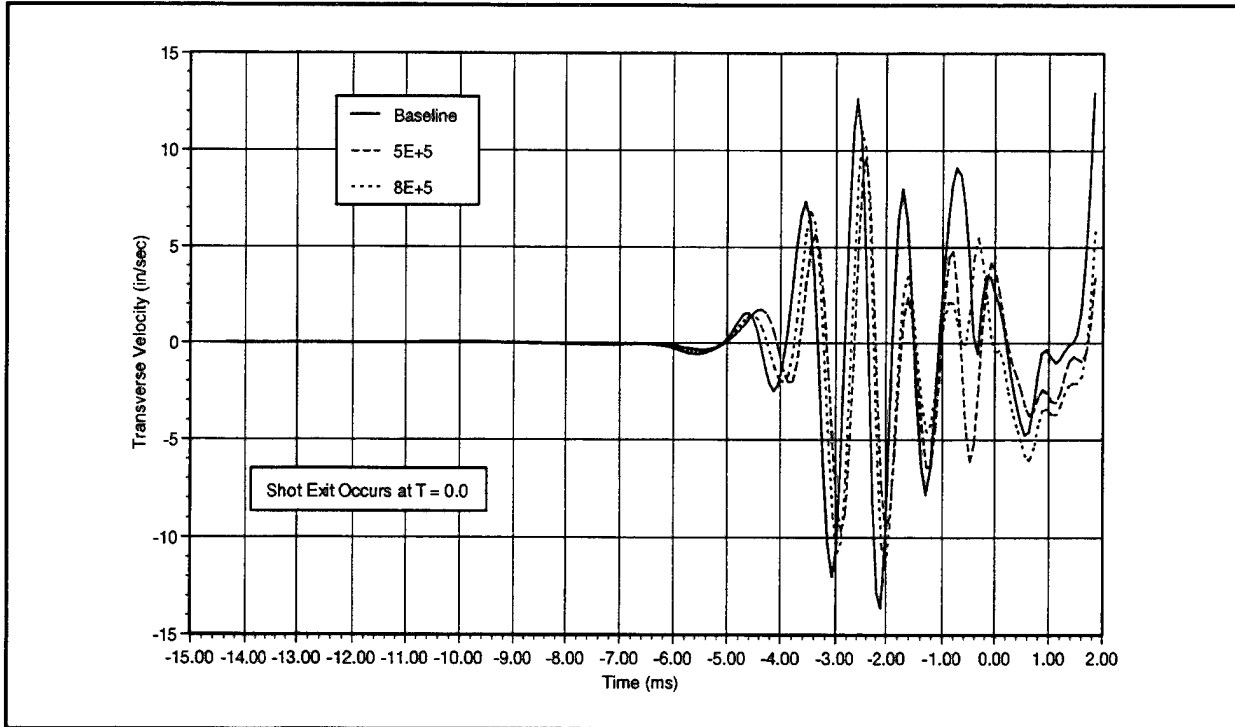

Figure 11. Transverse velocity of gun muzzle (S/N 17343) using base and softer spring constants of forward bourrelet.

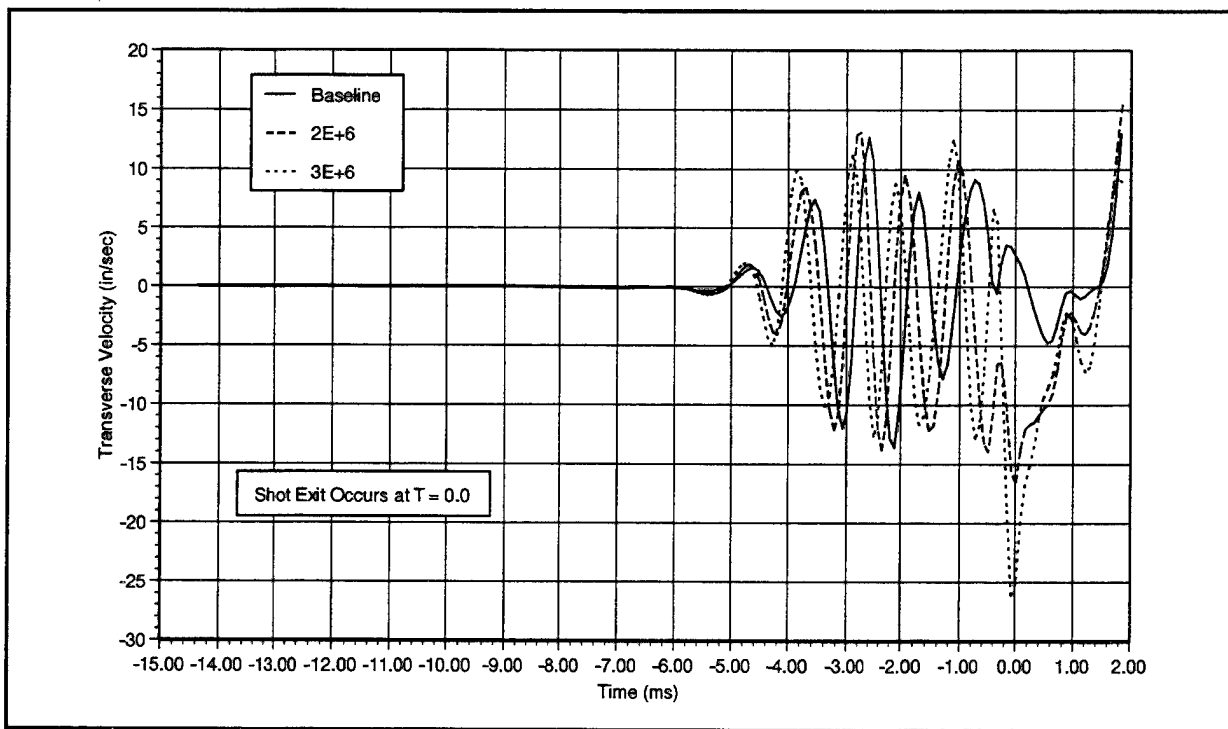

Figure 12. Transverse velocity of gun muzzle (S/N 17343) using base and harder spring constants of forward bourrelet.

These results prompted further investigation of the potential impact of changes to the forward bourrelet spring constant on range dispersion. Using the procedure previously described, a series of trajectory calculations was performed for each initial condition at a gun elevation corresponding to a nominal range of 7,500 yd (5,212 m). The results of these calculations are shown in Figures 13 and 14.

As expected, the changes in range dispersion that resulted from changes to the spring constant of the forward bourrelet are significantly larger than those for corresponding changes to the aft bourrelet. Although this study analyzed the response of only two individual gun barrels, these results would seem to indicate that if further improvements in the ballistic dispersion of the 5"/54 gun system are to be realized, then attention must be focused on the gun barrel manufacturing process with the objective of producing gun barrels whose characteristic centerline variations are more consistent.

5. SUMMARY AND CONCLUSIONS

The ballistic tools used in this study are proven products. They are fast, and as shown in this report, produce reasonable first-order results. Utilizing the analysis methodology described in this report, these models produce estimates of the ballistic dispersion of the 5"/54 gun system, that compare favorably to available proving ground data. In addition, these simulations were used to analyze the effect on shot exit conditions due to changes on a single, major parameter of the gun mount or the projectile. The results of these analyses indicate that major changes in the spring constant of the gun supports produce negligible effects on the projectile at shot exit. Much more noticeable changes in shot exit conditions occur when the projectile's contact spring coefficient changes. This is especially true when the forward bourrelet spring constant is changed.

One of the more important conditions to note in this gun system is that the very small center of gravity offsets in the breech have an insignificant effect on the dynamic response of the gun. The results indicate that each individual gun barrel centerline produces a unique gun response. This unique response appears to cause the mean achieved range for a fixed set of firing conditions to be

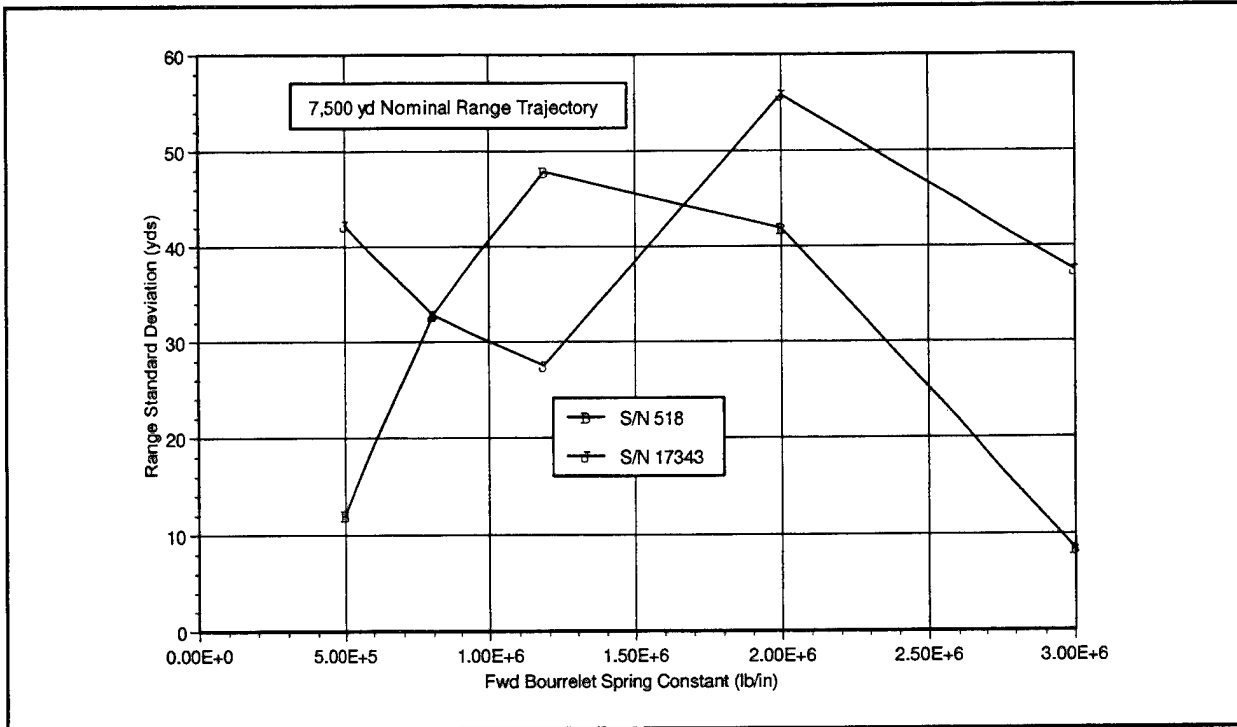

Figure 13. Effect of variations in forward bourrelet spring constant.

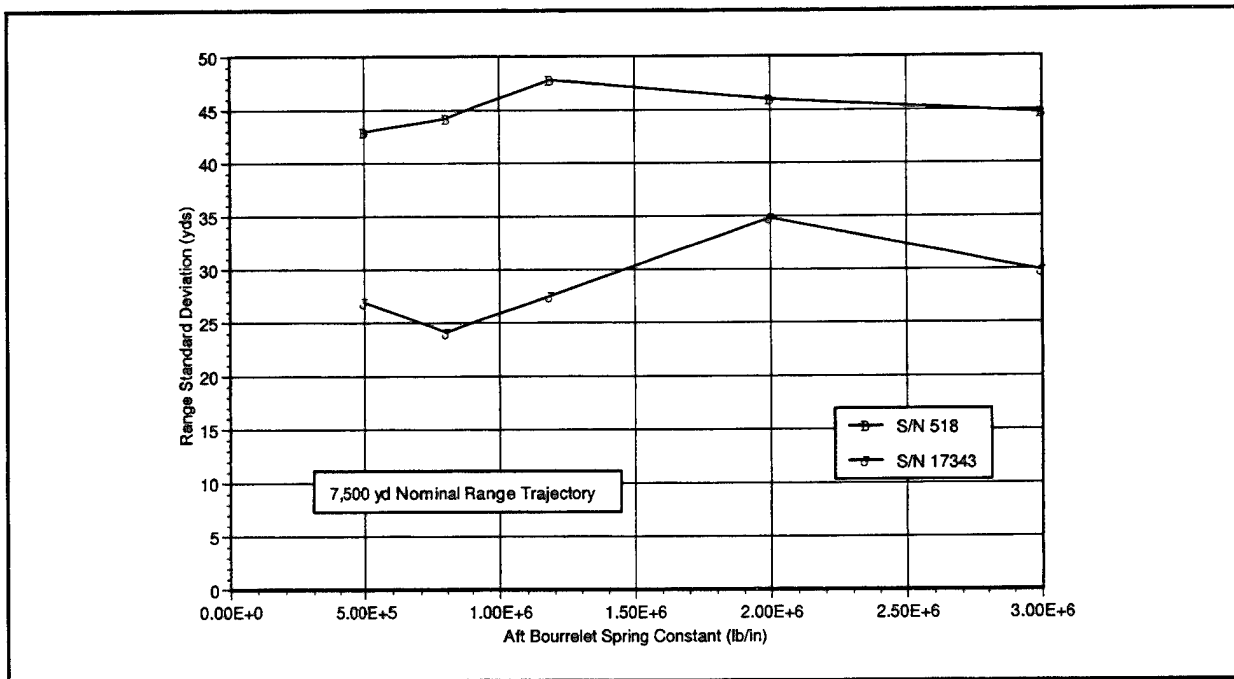

Figure 14. Effect of variations in aft bourrelet spring constant.

different for each gun barrel. This unique response may be the root cause of the short shooter or long shooter characteristic often observed in the 5"/54 and other long-range-type gun systems.

The analyses conducted during this investigation have yielded a considerable volume of information about the overall dynamic response characteristics of the 5"/54 gun system. A complete presentation of the data derived to date is far beyond the scope of this report. The interpretation of this information is an ongoing process and will undoubtedly lead to a more complete understanding of the key factors that influence the ballistic dispersion of the Mk 45 gun mount.

While the dynamic response of large-caliber indirect-fire gun systems is a relatively minor contributor to the overall delivery error, the importance of understanding the magnitude and source of all errors cannot be overstated. As the range of indirect-fire gun weapon systems is increased and greater emphasis is placed on improving delivery accuracy at these extended ranges, the need to identify, quantify, and understand the interdependencies of all sources of error will become increasingly important. Because of the ever-increasing cost of conducting live firing tests, computer modeling and simulation are often the only affordable means available to acquire the necessary knowledge and understanding necessary to make intelligent decisions concerning the overall accuracy potential of a gun weapon system. However, as the speed and power of computers have continued to increase, so have the sophistication and complexity of the models. Although these models are capable of providing precise information, often at levels of detail heretofore impossible to instrument, the time and expense required to develop and calibrate these models for existing weapon systems are often prohibitive. Therefore, there is a definite need for an accurate and simple means of conducting the quick-look-type analyses and first-order effect assessments necessary to guide and focus the application of more sophisticated techniques.

Although this study has admittedly been limited in scope, the authors believe that the analysis methodology developed during the investigation and described in this report offers a relatively simple and effective means of characterizing the dynamic response of a large-caliber gun system and assessing that system's sensitivity to changes in key parameters that affect its dynamic response. This

desktop procedure provides the gun and ammunition designer with an effective tool to quickly and economically assess the potential impact of proposed changes to key system parameters and can also provide design guidance during the early stages of new system development.

6. REFERENCES

- Anderson, R. D., and K. D. Fickie. "IBHVG2 - A User's Guide." BRL-TR-2829, U.S. Army Ballistic Research Laboratory, Aberdeen Proving Ground, MD, 1987.
- Erline, T. F. "Projectile Spring Constants: Significance to Modeling with the Little Rascal Gun Dynamics Program." BRL-TR-3224, U.S. Army Ballistic Research Laboratory, Aberdeen Proving Ground, MD, April 1991.
- Erline, T. F., and M. D. Kregel. "Modeling Gun Dynamics with Dominant Loads." BRL-MR-3683, U.S. Army Ballistic Research Laboratory, Aberdeen Proving Ground, MD, July 1988.
- Erline, T. F., M. D. Kregel, and M. Pantano. "Gun and Projectile Flexural Dynamics Modeled by the Little Rascal - A User's Manual." BRL-TR-3122, U.S. Army Ballistic Research Laboratory, Aberdeen Proving Ground, MD, July 1990.
- Jones, J. H., and E. G. Updike. "Quick-Look Results of 5-in/54 HECVT Ammunition-Effectiveness Test Against Land Targets Fired in USS LABOON on 2 Jun 1995." NSWCDD/TR-95/144, Dahlgren Division, Naval Surface Warfare Center, Dahlgren, VA, 1995.
- Kregel M. D., and E. L. Lortie. "Description and Comparison of the 'K' Method for Performing Numerical Integration of Stiff Ordinary Differential Equations." BRL-TR-1733, U.S. Army Ballistic Research Laboratory, Aberdeen Proving Ground, MD, July 1973.
- Lyon, D. "Radial Stiffness Measurements of 120-mm Tank Projectiles." ARL-TR-392, U.S. Army Research Laboratory, Aberdeen Proving Ground, MD, April 1994.
- Naval Sea Systems Command. "Range Table for 5-in 54-cal. Guns Firing Projectiles Mark 41 and Mark 64 (Surface Targets) (Full Service Charge, ICAO Atmosphere)." SW323-AB-ORD-020, Washington, DC, 1985.
- Updike, E. G. Private communication. Dahlgren Division, Naval Surface Warfare Center, Dahlgren, VA, February 1996.
- Thomson, W. T. Theory of Vibrations With Applications. Englewood Cliffs, NJ: Prentice-Hall, p. 142, 1981.

INTENTIONALLY LEFT BLANK.

<u>NO. OF COPIES</u>	<u>ORGANIZATION</u>	<u>NO. OF COPIES</u>	<u>ORGANIZATION</u>
2	DEFENSE TECHNICAL INFORMATION CENTER DTIC DDA 8725 JOHN J KINGMAN RD STE 0944 FT BELVOIR VA 22060-6218	1	INST FOR ADVNCD TCHNLGY THE UNIV OF TEXAS AT AUSTIN PO BOX 202797 AUSTIN TX 78720-2797
1	HQDA DAMO FDQ DENNIS SCHMIDT 400 ARMY PENTAGON WASHINGTON DC 20310-0460	1	DUSD SPACE 1E765 J G MCNEFF 3900 DEFENSE PENTAGON WASHINGTON DC 20301-3900
1	CECOM SP & TRRSTRL COMMCTN DIV AMSEL RD ST MC M H SOICHER FT MONMOUTH NJ 07703-5203	1	USAASA MOAS AI W PARRON 9325 GUNSTON RD STE N319 FT BELVOIR VA 22060-5582
1	PRIN DPTY FOR TCHNLGY HQ US ARMY MATCOM AMCDCG T M FISETTE 5001 EISENHOWER AVE ALEXANDRIA VA 22333-0001	1	CECOM PM GPS COL S YOUNG FT MONMOUTH NJ 07703
1	PRIN DPTY FOR ACQUSTN HQS US ARMY MATCOM AMCDCG A D ADAMS 5001 EISENHOWER AVE ALEXANDRIA VA 22333-0001	1	GPS JOINT PROG OFC DIR COL J CLAY 2435 VELA WAY STE 1613 LOS ANGELES AFB CA 90245-5500
1	DPTY CG FOR RDE HQS US ARMY MATCOM AMCRD BG BEAUCHAMP 5001 EISENHOWER AVE ALEXANDRIA VA 22333-0001	1	ELECTRONIC SYS DIV DIR CECOM RDEC J NIEMELA FT MONMOUTH NJ 07703
1	DPTY ASSIST SCY FOR R&T SARD TT T KILLION THE PENTAGON WASHINGTON DC 20310-0103	3	DARPA L STOTTS J PENNELLA B KASPAR 3701 N FAIRFAX DR ARLINGTON VA 22203-1714
1	OSD OUSD(A&T)/ODDDR&E(R) J LUPO THE PENTAGON WASHINGTON DC 20301-7100	1	SPCL ASST TO WING CMNDR 50SW/CCX CAPT P H BERNSTEIN 300 O'MALLEY AVE STE 20 FALCON AFB CO 80912-3020
		1	USAF SMC/CED DMA/JPO M ISON 2435 VELA WAY STE 1613 LOS ANGELES AFB CA 90245-5500

NO. OF
COPIES ORGANIZATION

1 US MILITARY ACADEMY
MATH SCI CTR OF EXCELLENCE
DEPT OF MATHEMATICAL SCI
MDN A MAJ DON ENGEN
THAYER HALL
WEST POINT NY 10996-1786

1 DIRECTOR
US ARMY RESEARCH LAB
AMSRL CS AL TP
2800 POWDER MILL RD
ADELPHI MD 20783-1145

1 DIRECTOR
US ARMY RESEARCH LAB
AMSRL CS AL TA
2800 POWDER MILL RD
ADELPHI MD 20783-1145

3 DIRECTOR
US ARMY RESEARCH LAB
AMSRL CI LL
2800 POWDER MILL RD
ADELPHI MD 20783-1145

ABERDEEN PROVING GROUND

3 DIR USARL
AMSRL CI LP (305)

<u>NO. OF COPIES</u>	<u>ORGANIZATION</u>
2	DNA INNOVATIVE CONCEPTS DIV J D HEWITT R ROHR 6801 TELEGRAPH RD ALEXANDRIA VA 22310-3398
2	CDR DARPA J KELLY B WILCOX 3701 N FAIRFAX DR ARLINGTON VA 22203-1714
5	HQDA SARD TR R CHAIT K KOMINOS SARD TT J APPEL F MILTON C NASH WASH DC 20310-0103
3	PEO ARMAMENTS TMAS AMCPM TMA COL BREGARD K KIMKER AMCPM TMA MD K KOWALSKI PCNTY ARSNL NJ 07806-5000
2	PM AFAS SFAE ASM AF G DELCOCO J SHIELDS PCNTY ARSNL NJ 07801-5000
3	PM FAS SFAE FAS PM D ADAMS T MCWILLIAMS H GOLDMAN PCNTY ARSNL NJ 07806-5000
2	PM SADARM PCNTY ARSNL NJ 07806-5000
4	DIR ARL AMSRL D J W LYONS AMSRL DD T A DUNN AMSRL SS (S3I) AMSRL WT L D WOODBURY 2800 POWDER MILL RD ADELPHI MD 20783-1197

<u>NO. OF COPIES</u>	<u>ORGANIZATION</u>
1	CDR TACOM AMSTA JSK S GOODMAN WARREN MI 48397-5000
1	CDR ARDEC F MCLAUGHLIN PCNTY ARSNL NJ 07806-5000
2	CDR ARDEC MSTA AR CC J HEDDERICH COL SINCLAIR PCNTY ARSNL NJ 07806-5000
6	CDR ARDEC AMSTA AR CCH T R CARR P CHRISTIAN J DELORENZO N KRASNOW S MUSALLI PCNTY ARSNL NJ 07806-5000
1	CDR ARDEC AMSTA AR CCH P J LUTZ PCNTY ARSNL NJ 07806-5000
1	CDR ARDEC AMSTA AR CCH V E FENNELL PCNTY ARSNL NJ 07806-5000
2	CDR ARDEC AMSTA AR FSA B MACHAK A WARNASH PCNTY ARSNL NJ 07806-5000
2	CDR ARDEC AMSTA AR FSA M D DEMELLA F DIORIO PCNTY ARSNL NJ 07806-5000
1	CDR ARDEC AMSTA AR FSE T GORA PCNTY ARSNL NJ 07806-5000
3	CDR ARDEC AMSTA AR TD V LINDNER R PRICE C SPINELLI PCNTY ARSNL NJ 07806-5000
1	CDR ARDEC AMSMC PBM K PCNTY ARSNL NJ 07806-5000

<u>NO. OF COPIES</u>	<u>ORGANIZATION</u>
9	DIR BENET LABORATORY AMSTA AR CCB G FFIAR J BATTAGLIA R HASENBEIN J KEANE V MONTVORI T SIMKINS J VASILAKIS J WRZOCHALSKI AMSTA AR CCB R S SOPOK WATERVLIET NY 12189-4050
3	CDR WATERVLIET ARSENAL AMSTA WV QA QS K INSCO AMSTA WV QAE Q B VANINA AMSTA WV SPM T MCCLOSKEY BLDG 25 3 WATERVLIET NY 12189-4050
3	CDR MICOM AMSMI RD W MCCORKLE AMSMI RD ST P DOYLE AMSMI RD ST CN T VANDIVER REDSTONE ARS AL 35898-5247
1	DIR USA CRREL P DUTTA 72 LYME RD HANOVER NH 03755
5	CDR ARO G ANDERSON J CHANDRA A CROWSON K IYER R SINGLETON PO BOX 12211 RSCH TRI PK NC 27709-2211
1	CDR USA BELVOIR RD&E CTR STRBE JBC FORT BELVOIR VA 22060-5606
1	USN EXPEDITIONARY WF DIV F SHOUP 2000 NAVY PENTAGON WASH DC 20350-2000
2	OFFICE OF NAVAL RSRCH CODE 351 D SIEGEL CODE 1132SM Y RAJAPAKSE 800 N QUINCY STREET ARLINGTON VA 22217-5660

<u>NO. OF COPIES</u>	<u>ORGANIZATION</u>
1	CDR NAVAL RSRCH LAB CODE 6383 I WOLOCK WASH DC 20375-5000
1	CDR NAVAL SEA SYS CMD DLIESE 2531 JEFFERSON DAVIS HWY ARLINGTON VA 22242-5160
10	CDR NSWC CODE G06 CODE G30 J H FRANCIS CODE G32 RD COOPER E WILKERSON D WILSON CODE G33 L DE SIMONE T DORAN R HUBBARD J FRAYSSE E ROWE DAHLGREN VA 22448-5000
1	CDR NSWC CRANE DIV CODE 20H4 M JOHNSON LOUISVILLE KY 40214-5245
3	DAVID TAYLOR RSCH CTR W PHYILLAJER R ROCKWELL CODE 1702 J CORRADO BETHESDA MD 20054-5000
1	CDR USMC SYS CMD PM GROUND WPNS R OWEN 2083 BARNETT AVE STE 315 QUANTICO VA 22134-5000
2	AFWL FTV A MAYER MLBM S DONALDSON 2941 P STREET STE 1 DAYTON OH 45433
2	NASA LANGLEY RSRCH CTR AMSRL VS MS 266 F BARTLETT JR W ELBER HAMPTON VA 23681-0001

<u>NO. OF</u> <u>COPIES</u>	<u>ORGANIZATION</u>	<u>NO. OF</u> <u>COPIES</u>	<u>ORGANIZATION</u>
3	DIR LANL F ADDRESSIO MS B 216 J REPPA MS F668 D RABERN MEE 13/MS J576 PO BOX 1663 LOS ALAMOS NM 87545	1	UCLA MANE DEPT ENGR IV H T HAHN LOS ANGELES CA 90024-1597
5	DIR LLNL R CHRISTENSEN S DETERESA M FINGER F MAGNESS M MURPHY PO BOX 808 LIVERMORE CA 94550-0622	1	UNIV OF TX AT AUSTIN CTR FOR ELECTROMECH J PRICE 10100 BURNET RD AUSTIN TX 78758-4497
1	DIR ORNL R M DAVIS PO BOX 2008 OAK RIDGE TN 37831-6195	1	AAI CORP T G STASTNY PO BOX 126 HUNT VALLEY MD 21030-0126
5	DIR SNL APPL MECH DEPT DIV 8241 D DAWSON W KAWAHARA P NIELAN K PERANO C ROBINSON PO BOX 969 LIVERMORE CA 94550-0096	6	ALLIANT TECHSYS INC R BECKER C CANDLAND D KAMDAR G KASSUELKE L LEE R LONG 600 SECOND ST NE HOPKINS MN 55343-8367
1	PACIFIC NW LABS M SMITH PO BOX 999 RICHLAND WA 99352	1	ARROW TECH ASSOC INC 1233 SHELBURNE RD STE D8 SO BURLINGTON VT 05403-7700
4	INST OF ADVANCED TECH UNIV OF TX AT AUSTIN W REINECKE H FAIR T KIEHNE P SULLIVAN 4030 2 W BRAKER LANE AUSTIN TX 78759-5329	1	BATTELLE C R HARGREAVES 505 KING AVE COLUMBUS OH 43201-2681
1	SOUTHWEST RSCH INST ENGRNG & MATL SCI DIV J P RIEGEL 6220 CULEBRA RD PO DRAWER 28510 SAN ANTONIO TX 78228-0510	1	BRIGS CO J BACKOFEN 2668 PETERBOROUGH ST HERNDON VA 22071-2443
		1	CUSTOM ANAL ENGRNG SYS INC A ALEXANDER 13000 TENSOR LANE NE FLINTSTONE MD 21530
		1	GENERAL DYNAMICS LAND SYS DIV D BARTLE PO BOX 1901 WARREN MI 48090

<u>NO. OF COPIES</u>	<u>ORGANIZATION</u>
13	UNITED DEFENSE LIMITED PARTNERSHIP T GIOVANETTI MAIL STOP 4781 P JANKE MAIL STOP 170 B VANWYK MAIL STOP 389 L FISCHER (10 CPS) 4800 EAST RIVER RD MINNEAPOLIS MN 55421-1498
1	IAP RSCH INC A CHALLITA 2763 CULVER AVE DAYTON OH 45429
1	INTERFEROMETRICS INC R LARRIVA VP 8150 LEESBURG PIKE VIENNA VA 22100
1	LORAL VOUGHT SYS PM ADVANCED CONCEPTS J TAYLOR MS WT 21 PO BOX 650003 DALLAS TX 76265-0003
2	LORAL VOUGHT SYS K COOK G JACKSON 1701 W MARSHALL DR GRAND PRAIRIE TX 75051
2	MARTIN MARIETTA CORP P DEWAR L SPONAR 230 E GODDARD BLVD KING OF PRUSSIA PA 19406
1	NOESIS INC A BOUTZ 1110 N GLEBE RD STE 250 ARLINGTON VA 22201-4795
2	OLIN CORP FLINCHBAUGH DIV E STEINER B STEWART PO BOX 127 RED LION PA 17356
1	OLIN CORP L WHITMORE 10101 9TH ST NO ST PETERSBURG FL 33702

<u>NO. OF COPIES</u>	<u>ORGANIZATION</u>
1	PROJECTILE TECH INC 515 GILES ST HAVRE DE GRACE MD 21078
1	SCIENCE APPL INTRNTNL CORP R ACEBAL 1225 JOHNSON FERRY BRD STE 100 MARIETTA GA 30068
1	SCIENCE APPL INTRNTNL CORP G CHRYSSOMALLIS 3800 W 80TH ST STE 1090 BLOOMINGTON MN 55431
1	SCIENCE APPL INTRNTNL CORP D DAKIN 2200 POWELL ST STE 1090 EMERYVILLE CA 94608
1	SCIENCE APPL INTRNTNL CORP M PALMER 2109 AIR PARK RD SE ALBUQUERQUE NM 87106
1	SPARTA INC J GLATZ 9455 TOWNE CTR DR SAN DIEGO CA 92121-1964
2	UNITED DEFENSE LP P PARA G THOMAS 1107 COLEMAN AVE BOX 367 SAN JOSE CA 95103
1	ZERNOW TECH SVCS L ZERNOW 425 W BONITA AVE STE 208 SAN DIMAS CA 91773
1	DR R EICHELBERGER CONSULTANT 409 W CATHERINE ST BEL AIR MD 21014-3613
1	JOHN HEBERT PO BOX 1072 HUNT VALLEY MD 21030-0126

NO. OF
COPIES ORGANIZATION

NO. OF
COPIES ORGANIZATION

ABERDEEN PROVING GROUND

1 DIR AMSAA
DRXSY MP

1 CDR ATC
STEAT-LI, R HENDRICKSEN

71 DIR USARL
ATTN AMSRL-CI, C MERMEGAN
AMSRL-CI-C, W STUREK
AMSRL-CI-CB, R KASTE
AMSRL-CI-S, A MARK
AMSRL-SL-B, P DIETZ
AMSRL-SL-BA
AMSRL-SL-BL, D BELY
AMSRL-SL-I, D HASKILL
AMSRL-WM, L JOHNSON
AMSRL-WM-M, G HAGNAUER
AMSRL-WM-MA, D GRANVILLE
AMSRL-WM-MF, T CHOU
AMSRL-WM-P,
A HORST
E SCHMIDT
AMSR-L-WM-PA,
D KOOKER
C LEVERITT
G KELLER
AMSRL-WM-PB,
P PLOSTINS
D LYON
D WEBB
A ZIELINSKI
AMSRL-WM-PC,
B FORCH
R FIFER
AMSRL-WM-PD,
J BENDER
B BURNS
L BURTON
W DRYSDALE
T ERLINE (10 CPS)
G GAZONAS
D HENRY
D HOPKINS
C HOPPEL
R KASTE
R KIRKENDALL
M LEADORE
R LIEB
J TZENG
S WILKERSON

AMSRL-WM-PD ALC,
A ABRAHAMIAN
K BARNES
M BERMAN
A FRYDMAN
T LI
W MCINTOSH
E SZYMANSKI
AMSRL-WM-T, W MORRISON
AMSRL-WM-TA,
W J BRUCHEY JR
W J GILLICH
AMSRL-WM-TC,
R COATES
W S DE ROSSET
K KIMSEY
AMSRL-WM-TD,
A M DIETRICH
A DAS GUPTA
G RANDERS-PEHRSON
AMSRL-WM-W, C MURHPY
AMSRL-WM-WA,
B MOORE
H ROGERS
AMSRL-WM-WB,
F BRANDON
W D'AMICO
AMSRL-WM-WC, J BORNSTEIN
AMSRL-WM-WD,
J POWELL
AMSRL-WM-WE,
J LACETERA
J THOMAS

<u>NO. OF COPIES</u>	<u>ORGANIZATION</u>	<u>NO. OF COPIES</u>	<u>ORGANIZATION</u>
1	DEUTSCHE AEROSPACE AG DYNAMIC SYSTEMS M HELD PO BOX 1340 D 86523 SCHROBENHAUSEN GERMANY	1	ERNST MACH INST G A SCHRODER HAUPTSTRASSE 18 79576 WEIL AM RHEIN GERMANY
2	DFNC RSCH AGENCY RARDE FORT HALSTEAD D SCOTT TM LAUNCH SYS P N JONES W7 DIV BLDG A20 SEVENOAKS KENT TN14 7BP UNITED KINGDOM	1	FOA NATNL DFNS RSCH ESTAB DEPT OF WPNS & PROTECTION B JANZON DIR S 172 90 STOCKHOLM SWEDEN
2	DFNC RSCH ESTAB VALCARTIER A DUPUIS F LESAGE PO BOX 8800 COURCELETTE QUEBEC GOA 1RO CANADA	2	INSTI SAINT LOUIS M GIRAUD C FAUQUIGNON 5 RUE DU GENERAL CASSAGNOU BOITE POSTALE 34 F 68301 SAINT LOUIS CEDEX FRANCE
1	DFNC SCI AND TECH ORG MATLS RSCH LABORATORY NPV SCHIP STRUCTURES & MATLS DIV N BURMAN PO BOX 50 ASCOT VALE VICTORIA AUSTRALIA 3032	1	ISRAEL INST OF TECHNOLOGY FACULTY OF MECH ENGRNG S BODNER HAIFA 3200 ISRAEL
2	DFNS TECH & PROC AGCY GRD H HAUS G LAUBE 3602 THUN SWITZERLAND	1	MINISTRY OF DFNC RAFAEL ARMAMENT DEV AUTHORITY M MAYSELESS PO BOX 2250 HAIFA 31021 ISRAEL
1	DYNAMIC RSCH AB A PERSSON PARADISGRND 7 S 151 36 SODERTALJE SWEDEN	3	ROYAL MIL COLLEGE OF SCI D BULMAN B LAWTON J D MACKWORTH SHRIVENHAM SWINDON WILTS SN 6 8LA UNITED KINGDOM
1	ECOLE ROYAL MILITAIRE E CELENS AVE DE LA RENAISSANCE 30 1040 BRUXELLE BELGIQUE	1	SWISS FED ARMAMENT WORKS W LANZ ALLMENDSTRASSE 86 3602 THUN SWITZERLAND
1	ERNST MACH INST A STILP EKERSTRASSE 4 7800 FREIBURG GERMANY	1	TNO DFNS RESEARCH I H PASMAN POSTBUS 6006 2600 JA DELFT THE NETHERLANDS

NO. OF
COPIES ORGANIZATION

- 1 TNO PRINS MAURITS LAB
R IJSSELSTEIN
LANGE KLEIWEG 137
PO BOX 45
2280 AA RIJSWIJK
THE NETHERLANDS
- 1 DR B HIRSCH
TACHKEMONY ST 6
NETAMUA 42611
ISRAEL

INTENTIONALLY LEFT BLANK.

REPORT DOCUMENTATION PAGE

Form Approved
OMB No. 0704-0188

Public reporting burden for this collection of information is estimated to average 1 hour per response, including the time for reviewing instructions, searching existing data sources, gathering and maintaining the data needed, and completing and reviewing the collection of information. Send comments regarding this burden estimate or any other aspect of this collection of information, including suggestions for reducing this burden, to Washington Headquarters Services, Directorate for Information Operations and Reports, 1216 Jefferson Davis Highway, Suite 1204, Arlington, VA 22202-4302, and to the Office of Management and Budget, Paperwork Reduction Project (0704-0188), Washington, DC 20503.

1. AGENCY USE ONLY (Leave blank)		2. REPORT DATE September 1997	3. REPORT TYPE AND DATES COVERED Final, Jan 96 - Aug 96	
4. TITLE AND SUBTITLE Rapid Assessment of Small Changes to Major Gun and Projectile Dynamic Parameters			5. FUNDING NUMBERS 1L162618AH80	
6. AUTHOR(S) Thomas F. Erline and Leo L. Fisher				
7. PERFORMING ORGANIZATION NAME(S) AND ADDRESS(ES) U.S. Army Research Laboratory ATTN: AMSRL-WM-PD Aberdeen Proving Ground, MD 21005-5066			8. PERFORMING ORGANIZATION REPORT NUMBER ARL-TR-1508	
9. SPONSORING/MONITORING AGENCY NAME(S) AND ADDRESS(ES)			10. SPONSORING/MONITORING AGENCY REPORT NUMBER	
11. SUPPLEMENTARY NOTES				
12a. DISTRIBUTION/AVAILABILITY STATEMENT Approved for public release; distribution is unlimited.			12b. DISTRIBUTION CODE	
13. ABSTRACT (Maximum 200 words) The U.S. Navy's 5-in 54-cal. (5"/54) gun system Mark (Mk) 45 was subjected to first-order dynamic analysis tools that allowed rapid assessment of ballistic dispersion of a typical naval high explosive projectile. The interior ballistics high-velocity gun version 2 (IBHVG2) modeled the 5-in propelling charge Mk 67, and gun barrel centerline data were obtained from two 5"/54 Mk 19 gun barrels. The "Little RASCAL" program was used to estimate the tipoff angles and angular rates for the Mk 64 5-in projectile, and the "PC-PRODAS" computer program was used to estimate the projectile yaw and yaw rates resulting from the bore and bourrelet clearance. The tipoff angles and rates obtained for the Little RASCAL program were then combined with the yaw data to establish a matrix of possible worst-case conditions of initial projectile yaw and yaw rate. A total of 32 possible muzzle exit conditions were identified and used as initial conditions for a 6 degrees of freedom trajectory program. The resulting variation in range obtained from the 32 trajectory calculations was used to calculate the range probable error. The results obtained from this relatively simple analysis technique have shown very good correlation with ballistic dispersion measurements made during actual firing tests.				
14. SUBJECT TERMS in-bore projectile dynamics, gun dynamics, shot exit conditions, ballistic dispersion, ballistic trajectory			15. NUMBER OF PAGES 38	
			16. PRICE CODE	
17. SECURITY CLASSIFICATION OF REPORT UNCLASSIFIED	18. SECURITY CLASSIFICATION OF THIS PAGE UNCLASSIFIED	19. SECURITY CLASSIFICATION OF ABSTRACT UNCLASSIFIED	20. LIMITATION OF ABSTRACT UL	

INTENTIONALLY LEFT BLANK.

USER EVALUATION SHEET/CHANGE OF ADDRESS

This Laboratory undertakes a continuing effort to improve the quality of the reports it publishes. Your comments/answers to the items/questions below will aid us in our efforts.

1. ARL Report Number/Author ARL-TR-1508 (Erline) Date of Report September 1997

2. Date Report Received _____

3. Does this report satisfy a need? (Comment on purpose, related project, or other area of interest for which the report will be used.) _____

4. Specifically, how is the report being used? (Information source, design data, procedure, source of ideas, etc.) _____

5. Has the information in this report led to any quantitative savings as far as man-hours or dollars saved, operating costs avoided, or efficiencies achieved, etc? If so, please elaborate. _____

6. General Comments. What do you think should be changed to improve future reports? (Indicate changes to organization, technical content, format, etc.) _____

CURRENT
ADDRESS

Organization

Name

E-mail Name

Street or P.O. Box No.

City, State, Zip Code

7. If indicating a Change of Address or Address Correction, please provide the Current or Correct address above and the Old or Incorrect address below.

OLD
ADDRESS

Organization

Name

Street or P.O. Box No.

City, State, Zip Code

(Remove this sheet, fold as indicated, tape closed, and mail.)

(DO NOT STAPLE)

DEPARTMENT OF THE ARMY

OFFICIAL BUSINESS

BUSINESS REPLY MAIL
FIRST CLASS PERMIT NO 0001,APG,MD

POSTAGE WILL BE PAID BY ADDRESSEE

DIRECTOR
US ARMY RESEARCH LABORATORY
ATTN AMSRL WM PD
ABERDEEN PROVING GROUND MD 21005-5066

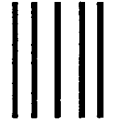

NO POSTAGE
NECESSARY
IF MAILED
IN THE
UNITED STATES

