

UMCS FEASIBILITY STUDY

ATTACHMENT SECTIONS 8.2 E THRU G & 8.6

FOR

Fort George G. Meade

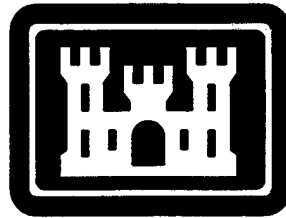

US Army Corps
of Engineers

U.S. ARMY ENGINEER DISTRICT, BALTIMORE
CORPS OF ENGINEERS
BALTIMORE, MARYLAND

PERFORMED BY

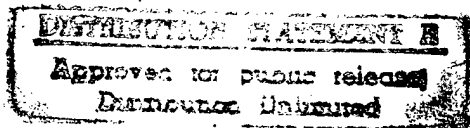

DTIC QUALITY INSPECTED 2,

ENTECH ENGINEERING INC.
READING, PENNSYLVANIA

DECEMBER 1996

VOLUME 3 OF 3

19971021 296



DEPARTMENT OF THE ARMY
CONSTRUCTION ENGINEERING RESEARCH LABORATORIES, CORPS OF ENGINEERS
P.O. BOX 9005
CHAMPAIGN, ILLINOIS 61826-9005

REPLY TO
ATTENTION OF: TR-I Library

17 Sep 1997

Based on SOW, these Energy Studies are unclassified/unlimited.
Distribution A. Approved for public release.

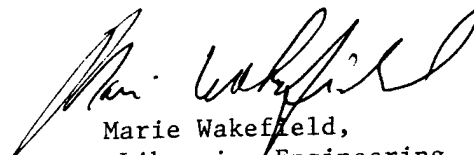
Marie Wakefield,
Librarian Engineering

ACKNOWLEDGEMENTS

Entech Engineering, Inc. acknowledges the cooperative support of the individuals listed below who contributed to the successful completion of this report.

Fort George G. Meade Department of Public Works

Randy Johnson, Chief, Management Engineering Systems Branch

Debbie Faux, Supervisor, Bachelor Housing Section

Bill Rumney, Control Technician, Bachelor Housing Section

U. S. Army Engineer District, Baltimore

Mary Ellen Peters, Project Manager

U. S. Army Engineer Division, Huntsville

Will White, Project Engineer

Entech Engineering, Inc.

Paul A. Hottenstein, Project Manager

Craig Snyder, Mechanical Engineer

Eric Goodman, Electrical Designer

Table of Contents

<u>Section</u>	<u>Title</u>	<u>Page</u>
1.0	EXECUTIVE SUMMARY	1-1 to 1-8
1.1	Introduction	1-1
1.2	Objective	1-1
1.3	Report Organization	1-2
1.4	Facilities Description	1-2
1.5	Energy Costs	1-3
1.6	Building By Building Analysis	1-4
1.7	Recommended UMCS Energy Conservation Opportunity	1-6
2.0	METHODOLOGY	2-1 to 2-25
2.1	General	2-1
2.2	Kickoff Meeting	2-1
2.3	Site Inspection/Data Collection	2-2
2.4	ESA Program	2-2
2.5	EZDOE Program	2-4
2.6	Energy Saving Control Strategies	2-6
	2.6.1 General	2-6
	2.6.2 Scheduled Start/Stop	2-9
	2.6.3 Optimum Start/Stop	2-9
	2.6.4 Duty Cycling	2-10
	2.6.5 Demand Limiting	2-10
	2.6.6 Day/Night Setback	2-11
	2.6.7 Economizer	2-11
	2.6.8 Ventilation and Recirculation	2-11
	2.6.9 Hot Deck/Cold Deck Temperature Reset	2-12
	2.6.10 Reheat Coil Reset	2-13
	2.6.11 Steam Boiler Selection	2-13
	2.6.12 Hot Water Outside Air Reset	2-14
	2.6.13 Chiller Selection	2-14
	2.6.14 Chilled Water Temperature Reset	2-15
	2.6.15 Condenser Water Temperature Reset	2-15
	2.6.16 Chiller Demand Limit	2-15
	2.6.17 Lighting Control	2-16
2.7	Btu/Unit	2-17
2.8	Building by Building UMCS Analysis and Base UMCS Analysis ...	2-17

Table of Contents

<u>Section</u>	<u>Title</u>	<u>Page</u>
	2.8.1 Existing Control Conditions	2-18
	2.8.2 Proposed Control Strategies	2-18
	2.8.3 Point List for Control Strategies	2-18
	2.8.4 Construction Cost Estimates	2-19
	2.8.5 Annual Energy Savings	2-20
	2.8.6 Economics	2-20
	2.8.7 Discussion	2-20
2.9	Life Cycle Cost Analysis Summary	2-21
2.10	Draft Report/Client Review/Final Report	2-24
3.0	FACILITY DESCRIPTION	3-1 to 3-16
3.1	General	3-1
3.2	Building Descriptions	Table 3.1
3.3	Existing Base EMCS System	3-1
4.0	ENERGY COSTS	4-1 to 4-15
4.1	Electric Rates	4-1
	4.1.1 Incremental Cost	4-1
4.2	Natural Gas Rates	4-3
4.3	Fuel Oil Rate	4-4
5.0	BUILDING BY BUILDING UMCS ANALYSIS	5-1 to 5-398
5.1	General	5-1
5.2	Building Summary UMCS Analysis	5-4
5.3	Building By Building Analysis	5-14
	Building 370 - NCO Dining	5-15
	Building 375 - Mail Room and Warehouse	5-21
	Building 393 - Administration	5-27
	Building 504 - Training Aids Center	5-33
	Building 909 - Youth Center	5-39
	Building 940 - Morale Support Office	5-45
	Building 1976 and 1978 - Warehouse and Administrative	5-51
	Building 2212 - Administrative	5-57
	Building 2220 - Repair Shop and Office	5-63
	Building 2234 - Administrative	5-69

Table of Contents

<u>Section</u>	<u>Title</u>	<u>Page</u>
	Building 2251 - Boiler Plant	5-75
	Building 2253 - Vehicle Maintenance Shop	5-76
	Building 2257 - Administrative	5-82
	Building 2282 - Administrative R&D	5-88
	Building 2481 - UEPH	5-94
	Building 2482 - Boiler Plant	5-100
	Building 2484 - Medical Warehouse	5-106
	Building 2490 - Laboratory	5-112
	Building 2501 - Administrative	5-118
	Building 2786 - Commissary	5-124
	Building 2789 - Post Office	5-130
	Building 2790 - Post Exchange	5-136
	Building 2793 - Guest Housing	5-142
	Building 2812 - Administrative	5-143
	Building 3000 - FE Facility	5-149
	Building 4215 - Administrative	5-155
	Building 4216 - Administrative	5-161
	Building 4217 - Administrative	5-167
	Building 4411 - Administrative	5-173
	Building 4418 - Post Library	5-179
	Building 4419 - Post Chapel	5-185
	Building 4431 - Theater	5-191
	Building 4432 - Administrative	5-197
	Building 4471 - Credit Union	5-203
	Building 4550 - Administrative	5-209
	Building 4551 - Administrative	5-215
	Building 4552 - Administrative	5-221
	Building 4553 - Administrative	5-227
	Building 4554 - Administrative	5-233
	Building 4587 - Exchange Service Outlet	5-239
	Building 4675 - Exchange Service Outlet	5-245
	Building 4680 - Exchange Service Station	5-250
	Building 4700 - Band Training Facility	5-256
	Building 4703, 4704, 4717, 4720 and 4721 - Offices' Quarters	5-262
	Building 4705, 4707 and 4709 - Offices' Quarters	5-268

Table of Contents

<u>Section</u>	<u>Title</u>	<u>Page</u>
	Building 6330 - Physical Fitness Center	5-274
	Building 6530 - Skill Development Center	5-280
	Building 6600 - Officer's Club	5-286
	Building 6800 - Club House	5-292
	Building 7100 - Chapel Center Facility	5-298
	Building 8452 - Recreation Center	5-304
	Building 8465 - Post Chapel	5-310
	Building 8472 - Dental Clinic	5-316
	Building 8476 - Battalion Headquarters Building	5-322
	Building 8477 - Battalion Headquarters Building	5-328
	Building 8478, 8479, 8544, 8545, 8605, 8607, 8609, 8610, and 8611 - UEPH	5-334
	Building 8481 - Boiler Plant	5-340
	Building 8485 and 8486 - Org. Vehicle Maintenance Shop	5-346
	Building 8606 - UEPH	5-352
	Building 9801, 9802, 9803 and 9804 - UEPH	5-358
	Building 9810 - Recreation Center	5-365
	Building 9827 - UEPH	5-372
	Building 9828 - UEPH	5-378
	Building 9829 - Enlisted Personnel Dining	5-384
6.0	BASE UMCS ENERGY CONSERVATION OPPORTUNITY	6-1 to 6-11
6.1	General	6-1
6.2	Base UMCS Energy Conservation Opportunity	6-2
7.0	CONCLUSION	7-1 to 7-2
8.0	ATTACHMENTS	
8.1	Scope of Services	
8.2	Building Envelope, Equipment Schedule, and ESA/EZDOE output	
	Section A Buildings 370 to 2490	
	Section B Buildings 2501 to 3000	
	Section C Buildings 4215 to 4471	
	Section D Buildings 4550 to 4552	
	Section E Buildings 4553 to 4554	

Table of Contents

<u>Section</u>	<u>Title</u>	<u>Page</u>
	Section F Buildings 4587 to 7100	
	Section G Buildings 8452 to 9829	
8.3	UMCS Cost Estimate - All Buildings	
8.4	UMCS Cost Estimate - Recommended ECO Buildings	
8.5	Interim Review Comments and Responses	
8.6	Lighting Control Switch Catalog Information	

Acronym Table

A/C	Air Conditioning
AHU	Air Handling Unit
BHP	Boiler Horse Power
BTU	British Thermal Unit
CHW	Chilled Water
DHW	Domestic Hot Water
DoD	Department of Defense
DPW	Department of Public Works
DX	Direct Expansion
ECIP	Energy Conservation Investment Program
ECO	Energy Conservation Opportunity
EEAP	Energy Engineering Analysis Program
EMCS	Energy Monitoring and Control System
EMS	Energy Management System
ESA	Energy Savings Analysis
gal	Gallon
HVAC	Heating, Ventilating, and Air Conditioning
HW	Hot Water
kW	Kilowatt
kWh	Kilowatt Hour
LCC	Life Cycle Cost
mcf	Thousand Cubic Feet
mmBTU	Million BTU
OA	Outside Air
SIOH	Savings, Inspection and Overhead
SIR	Savings to Investment Ratio
UMCS	Monitoring and Control System
VAV	Variable Air Volume

ATTACHMENT SECTION 8.2E

BUILDINGS 4553 TO 4554

FT. MEADE, MARYLAND

Building: 4553

Square feet 103,938

Exterior Wall	
Components	R-Value
Outside Surface	0.17
Brick	0.44
Air Space	1.10
Concrete Block	1.72
Plaster	0.56
Inside Surface	0.68
Total R-Value	4.67
Total U-Value	0.21

Exterior Roof	
Components	R-Value
Outside Surface	0.17
Slate	0.33
Wood Deck	0.93
2" Insulation	12.00
Plaster Clg	0.56
Inside Surface	0.61
Total R-Value	14.60
Total U-Value	0.07

Calculated Total Area	
No. of Floors	4
Avg. Floor to Floor Height	12
No. of Basement Levels	1
Gross Floor Area	103938
Roof Area	20800
Estimated Infiltration (cfm)	10400
Gross Wall Area	57430
Door Area	200
Gross Window Area	1350
Other	
Net Wall Area	55880

Window and Door	
	U-Value
Window Single Pane W/Storm	0.60
Window Single Pane Wo/Storm	
Window Double Pane	
Skylight	
Glass Block	
Other	
Door Type 1	0.50
Door Type 2	
Door Type 3	

FT. MEADE, MARYLAND
EQUIPMENT SCHEDULE

EQUIPMENT	SYSTEM NUMBER							
	1	2	3	4	5	6	7	8
Equipment Name	AC-5	AC-6	AC-7	AC-8	AC-9	AC-10	AC-11	AC-12
COOLING:								
Type of Cooling	1	1	1	1	1	1	1	1
Air Side	1	2	2	2	1	2	2	2
Location in Building	BSMT A&B	1st Fir A&B	2nd Fir A&B	3rd Fir A&B	BSMT C&D	1st Fir C&D	2nd Fir C&D	3rd Fir C&D
Area Sq. Feet	5200	10400	10400	9200	10400	10400	10400	11600
Supply CFM	4750	14595	17580	18705	10480	12330	14635	16555
Supply Fan HP	2	15	15	20	10	15	15	20
O.A. CFM or %	20%	20%	20%	20%	33%	20%	20%	20%
Return CFM								
Return Fan HP								
Chiller Tonnage	15	30	40	40	20	30	40	40
Tower or Condenser Fan HP	2/3	3	5	5	3	3	3	5
Condenser Pump HP								
Chilled Water Pump HP								
HEATING:								
Type of Heating								
Source								
MBTUH								
Hot Water Pump HP								
Condensate Pump HP								
ADDITIONAL:								
Aux. HP Cooling								
Aux. HP Heating								
Operating Schedule Hrs./Week								
	Type of Cooling		Type of Heating					
(1) Air Cooled DX	(4) Water Cooled Chiller		(1) Boiler Hot Water		(4) Furnace			
(2) Water Cooled DX	(5) Central Plant Supplied		(2) Boiler Steam					
(3) Air Cooled Chiller	(6) Other		(3) Steam to Hot Water Converter					
	Air Side		Heating Source					
(1) Single Zone	(4) VAV w/ Reheat		(1) Natural Gas		(4) Oil			
(2) Multi-Zone	(5) Constant Volume Reheat		(2) Central Plant Steam		(5) Electric			
(3) VAV	(6) Heating and Ventilating		(3) Central Plant Hot Water					

**FT. MEADE, MARYLAND
EQUIPMENT SCHEDULE**

BUILDING NO. 4553

Page 2 of 2

EQUIPMENT	SYSTEM NUMBER							
	1	2	3	4	5	6	7	8
Equipment Name	AC-23	BOILER	BOILER					
COOLING:								
Type of Cooling	1							
Air Side	1							
Location in Building	1st Fir A wing							
Area Sq. Feet	2400							
Supply CFM	2975							
Supply Fan HP	1							
O.A. CFM or %	20%							
Return CFM								
Return Fan HP								
Chiller Tonnage	10							
Tower or Condenser Fan HP	2/3							
Condenser Pump HP								
Chilled Water Pump HP								
HEATING:								
Type of Heating	1	1	1					
Source	1	1	1					
MBTUH		2520/1640	2520/1640					
Hot Water Pump HP		6.5	6.5					
Condensate Pump HP								
ADDITIONAL:								
Aux. HP Cooling								
Aux. HP Heating								
Operating Schedule Hrs./Week								
Type of Cooling	(4) Water Cooled Chiller (5) Central Plant Supplied (6) Other			Type of Heating (1) Boiler Hot Water (2) Boiler Steam (3) Steam to Hot Water Converter (4) Furnace				
Air Side	(4) VAV w/ Reheat (5) Constant Volume Reheat (6) Heating and Ventilating			Heating Source (1) Natural Gas (2) Central Plant Steam (3) Central Plant Hot Water (4) Oil (5) Electric				

EMCS Annual Energy Savings Summary Report

```

=====
Base: FTMEADE
Building: 4553
Case: 1
Description:
-----
Fuel Type: Natural gas (methane)
Heating Value: 1,031 Btu/cf
=====
    
```

Caution

```

=====
The ESA program makes no attempt to exclude incompatible strategies.
It is the user's responsibility to select all appropriate strategies.
=====
    
```

Annual Energy Savings Table for Multi-zone DX-A/C

```

=====
Description: MULTI-ZONE UNITS (6)
=====
Strategy                MBtu/yr      kWh/yr      kW   mh/yr
=====
Demand Limiting          0.000         0           14.9  0
Hot/Cold Deck Reset     588.498      30,263      0.0   0
-----
Subtotals                588.498      30,263      14.9  0
Heating Value /         1,031 Btu/cf
=====
Totals                  570,803      30,263      14.9  0
                        cf /yr      kWh/yr      kW   mh/yr
=====
    
```

Annual Energy Savings Table for Hot Water Boiler

```

=====
Description: BOILER
=====
Strategy                MBtu/yr      kWh/yr      kW   mh/yr
=====
Hot Water OA Reset      465.231         0           0.0   0
-----
Subtotals                465.231         0           0.0   0
Heating Value /         1,031 Btu/cf
=====
Totals                  451,242         0           0.0   0
                        cf /yr      kWh/yr      kW   mh/yr
=====
    
```

Annual Energy Savings Table for Lighting Control

Description: LIGHTING				
Strategy	MBtu/yr	kWh/yr	kW	mh/yr
Lighting Control	0.000	122,304	0.0	0
Totals	0.000	122,304	0.0	0
	MBtu/yr	kWh/yr	kW	mh/yr

EMCS Annual Energy Savings for Building 4553

Description	Value	Units
Natural gas (methane)	1,022,046	cf /yr
Electrical Energy	152,567	kWh/yr
Electrical Demand Reduction	14.9	kW
Labor Savings	0	mh/yr

**UMCS FEASIBILITY STUDY
FORT MEADE
BUILDING 4553 - ADMINISTRATIVE
DOE ENERGY SAVINGS SUMMARY**

	Space Heat		Space Cool		HVAC Aux		Lights		Misc Equip		TOTAL		TOTAL		
	Electricity mmBtu	Natural Gas mmBtu	Electricity mmBtu	Electricity mmBtu	Electricity mmBtu	Electricity mmBtu	Electricity mmBtu	Electricity mmBtu	Electricity mmBtu	Electricity mmBtu	Natural Gas mmBtu	Electricity Kwh	Natural Gas MCF	Electricity Kwh	Natural Gas MCF
Existing	227.8	7,139.9	952.2	2,030.8	1,701.4	867.9	5,780.0	7,139.9	1,693,528	6,925.2					
New w/Night Setback	109.1	2,792.6	554.9	812.7	1,701.4	867.9	4,045.9	2,792.6	1,185,438	2,708.6					
Night Setback Savings							1,734.1	4,347.4	508,090	4,216.7					
New w/Night Setback and Vent/Recirc	100.1	2,535.7	565.5	785.9	1,701.4	867.9	4,020.7	2,535.7	1,178,060	2,459.5					
Vent/Recirc Savings							25.2	256.9	7,378	249.1					
New w/Night Setback & Vent/Recirc & Temp Reset	94.3	2,129.8	507.6	779.4	1,701.4	867.9	3,950.6	2,129.8	1,157,504	2,065.8					
Temp Reset Savings							70.2	405.9	20,557	393.7					

MMDDHH	AC-1	AC-1	AC-1	AC-1	AC-1	AC-2	AC-2	AC-2
	TOT HTG COIL PWR BTU/HR	SUPPLY ELECTRIC KW	HEATING CAPACITY BTU/HR	COOLING ELECTRIC KW	COOLING CAPACITY BTU/HR	TOT HTG COIL PWR BTU/HR	SUPPLY ELECTRIC KW	HEATING CAPACITY BTU/HR
	---- (5)	----(49)	----(78)	----(47)	----(70)	---- (5)	----(49)	----(78)
MONTHLY SUMMARY (JAN)								
MN	-151338.	3.795	-202077.	0.000	198036.	-334056.	8.802	-468716.
MX	-24979.	3.795	-202077.	0.000	201884.	-23388.	8.802	-468716.
SM	-70745440.	2823.406	-150345056.	0.000	147345296.	-131993064.	6548.872	-348724672.
AV	-95088.	3.795	-202077.	0.000	198045.	-177410.	8.802	-468716.
MONTHLY SUMMARY (FEB)								
MN	-161050.	3.795	-202077.	0.000	198036.	-341156.	8.802	-468716.
MX	-26223.	3.795	-202077.	0.000	207757.	-14.	8.802	-468716.
SM	-67586784.	2550.173	-135795536.	0.000	133181640.	-109898960.	5915.110	-314977120.
AV	-100576.	3.795	-202077.	0.000	198187.	-163540.	8.802	-468716.
MONTHLY SUMMARY (MAR)								
MN	-139728.	3.795	-202077.	0.000	194105.	-267461.	8.802	-468716.
MX	-13958.	3.795	-202077.	0.000	215019.	-8.	8.802	-468716.
SM	-66159992.	2823.406	-150345056.	0.000	147487632.	-78415800.	6548.872	-348724672.
AV	-88925.	3.795	-202077.	0.000	198236.	-105398.	8.802	-468716.
MONTHLY SUMMARY (APR)								
MN	-125498.	3.795	-202077.	0.000	190175.	-224237.	8.802	-468716.
MX	-1657.	3.795	-202077.	0.000	218850.	-2.	8.802	-468716.
SM	-54051576.	2732.328	-145495216.	0.000	143272320.	-41784256.	6337.618	-337475488.
AV	-75072.	3.795	-202077.	0.000	198989.	-58034.	8.802	-468716.
MONTHLY SUMMARY (MAY)								
MN	0.	3.795	0.	0.000	181768.	0.	8.802	0.
MX	0.	3.795	0.	0.000	230919.	0.	8.802	0.
SM	0.	2823.406	0.	0.000	149338240.	0.	6548.872	0.
AV	0.	3.795	0.	0.000	200723.	0.	8.802	0.
MONTHLY SUMMARY (JUN)								
MN	0.	3.795	0.	0.000	181768.	0.	8.802	0.
MX	0.	3.795	0.	9.916	236347.	0.	8.802	0.
SM	0.	2732.328	0.	603.219	150643120.	0.	6337.618	0.
AV	0.	3.795	0.	0.838	209227.	0.	8.802	0.
MONTHLY SUMMARY (JUL)								
MN	0.	3.795	0.	0.000	185147.	0.	8.802	0.
MX	0.	3.795	0.	12.718	246939.	0.	8.802	0.
SM	0.	2823.406	0.	1888.560	160566528.	0.	6548.872	0.
AV	0.	3.795	0.	2.538	215815.	0.	8.802	0.

	AC-1	AC-1	AC-1	AC-1	AC-1	AC-2	AC-2	AC-2
	TOT HTG COIL PWR BTU/HR	SUPPLY ELECTRIC KW	HEATING CAPACITY BTU/HR	COOLING ELECTRIC KW	COOLING CAPACITY BTU/HR	TOT HTG COIL PWR BTU/HR	SUPPLY ELECTRIC KW	HEATING CAPACITY BTU/HR
	----(5)	----(49)	----(78)	----(47)	----(70)	----(5)	----(49)	----(78)
MONTHLY SUMMARY (AUG)								
MN	0.	3.795	0.	0.000	190166.	0.	8.802	0.
MX	0.	3.795	0.	14.087	238314.	0.	8.802	0.
SM	0.	2823.406	0.	2895.442	158223952.	0.	6548.872	0.
AV	0.	3.795	0.	3.892	212667.	0.	8.802	0.
MONTHLY SUMMARY (SEP)								
MN	0.	3.795	0.	0.000	190717.	0.	8.802	0.
MX	0.	3.795	0.	13.110	238264.	0.	8.802	0.
SM	0.	2732.328	0.	1755.637	148708240.	0.	6337.618	0.
AV	0.	3.795	0.	2.438	206539.	0.	8.802	0.
MONTHLY SUMMARY (OCT)								
MN	-130395.	3.795	-202077.	0.000	187378.	-300623.	8.802	-468716.
MX	0.	3.795	0.	9.165	216871.	0.	8.802	0.
SM	-23057172.	2823.406	-77597448.	1996.208	148874960.	-55228744.	6548.872	-179986928.
AV	-30991.	3.795	-104298.	2.683	200101.	-74232.	8.802	-241918.
MONTHLY SUMMARY (NOV)								
MN	-80705.	3.795	-202077.	0.000	198036.	-200206.	8.802	-468716.
MX	-9.	3.795	-202077.	0.000	244880.	0.	8.802	-468716.
SM	-30915672.	2732.328	-145495216.	0.000	144573344.	-67373792.	6337.618	-337475488.
AV	-42938.	3.795	-202077.	0.000	200796.	-93575.	8.802	-468716.
MONTHLY SUMMARY (DEC)								
MN	-120830.	3.795	-202077.	0.000	198036.	-287048.	8.802	-468716.
MX	-219.	3.795	-202077.	0.000	210598.	-4046.	8.802	-468716.
SM	-54136224.	2823.406	-150345056.	0.000	147486336.	-115888240.	6548.872	-348724672.
AV	-72764.	3.795	-202077.	0.000	198234.	-155764.	8.802	-468716.
YEARLY SUMMARY								
MN	-161050.	3.795	-202077.	0.000	181768.	-341156.	8.802	-468716.
MX	0.	3.795	0.	14.087	246939.	0.	8.802	0.
SM	-366652896.	33243.328	-955418624.	9139.067	1779701632.	-600582848.	77107.688	-2216089088.
AV	-41855.	3.795	-109066.	1.043	203162.	-68560.	8.802	-252978.

MMDDHH	AC-2	AC-2	AC-3	AC-3	AC-3	AC-3	AC-3	AC-4
	COOLING ELECTRIC KW	COOLING CAPACITY BTU/HR	TOT HTG COIL PWR BTU/HR	SUPPLY ELECTRIC KW	HEATING CAPACITY BTU/HR	COOLING ELECTRIC KW	COOLING CAPACITY BTU/HR	TOT HTG COIL PWR BTU/HR
	----(47)	----(70)	----(5)	----(49)	----(78)	----(47)	----(70)	----(5)
MONTHLY SUMMARY (JAN)								
MN	0.000	474122.	-334056.	8.802	-468716.	0.000	474122.	-473503.
MX	0.000	485539.	-23388.	8.802	-468716.	0.000	485539.	-57582.
SM	0.000	352771552.	-131993064.	6548.872	-348724672.	0.000	352771552.	-196459024.
AV	0.000	474155.	-177410.	8.802	-468716.	0.000	474155.	-264058.
MONTHLY SUMMARY (FEB)								
MN	0.000	474122.	-341156.	8.802	-468716.	0.000	474122.	-463433.
MX	0.000	499462.	-14.	8.802	-468716.	0.000	499462.	-15.
SM	0.000	318842400.	-109898960.	5915.110	-314977120.	0.000	318842400.	-162007040.
AV	0.000	474468.	-163540.	8.802	-468716.	0.000	474468.	-241082.
MONTHLY SUMMARY (MAR)								
MN	0.000	464949.	-267461.	8.802	-468716.	0.000	464949.	-369104.
MX	0.000	517514.	-8.	8.802	-468716.	0.000	517514.	-9.
SM	0.000	353150112.	-78415800.	6548.872	-348724672.	0.000	353150112.	-121846872.
AV	0.000	474664.	-105398.	8.802	-468716.	0.000	474664.	-163773.
MONTHLY SUMMARY (APR)								
MN	0.000	469397.	-224237.	8.802	-468716.	0.000	469397.	-316907.
MX	0.000	543781.	-2.	8.802	-468716.	0.000	543781.	-2.
SM	0.000	343859104.	-41784256.	6337.618	-337475488.	0.000	343859104.	-68599216.
AV	0.000	477582.	-58034.	8.802	-468716.	0.000	477582.	-95277.
MONTHLY SUMMARY (MAY)								
MN	0.000	435174.	0.	8.802	0.	0.000	435174.	0.
MX	20.842	532512.	0.	8.802	0.	20.842	532512.	0.
SM	2388.177	358162752.	0.	6548.872	0.	2388.177	358162752.	0.
AV	3.210	481402.	0.	8.802	0.	3.210	481402.	0.
MONTHLY SUMMARY (JUN)								
MN	0.000	437389.	0.	8.802	0.	0.000	437389.	0.
MX	40.205	534002.	0.	8.802	0.	40.205	534002.	0.
SM	7863.937	354172768.	0.	6337.618	0.	7863.937	354172768.	0.
AV	10.922	491907.	0.	8.802	0.	10.922	491907.	0.
MONTHLY SUMMARY (JUL)								
MN	0.000	441847.	0.	8.802	0.	0.000	441847.	0.
MX	42.867	546224.	0.	8.802	0.	42.867	546224.	0.
SM	10850.098	373741920.	0.	6548.872	0.	10850.098	373741920.	0.
AV	14.583	502341.	0.	8.802	0.	14.583	502341.	0.

	AC-2	AC-2	AC-3	AC-3	AC-3	AC-3	AC-3	AC-4
	COOLING ELECTRIC KW	CAPACITY BTU/HR	TOT HTG COIL PWR BTU/HR	SUPPLY ELECTRIC KW	HEATING CAPACITY BTU/HR	COOLING ELECTRIC KW	CAPACITY BTU/HR	TOT HTG COIL PWR BTU/HR
	----(47)	----(70)	----(5)	----(49)	----(78)	----(47)	----(70)	----(5)
MONTHLY SUMMARY (AUG)								
MN	0.000	454223.	0.	8.802	0.	0.000	454223.	0.
MX	40.117	539487.	0.	8.802	0.	40.117	539487.	0.
SM	10153.345	373512192.	0.	6548.872	0.	10153.345	373512192.	0.
AV	13.647	502033.	0.	8.802	0.	13.647	502033.	0.
MONTHLY SUMMARY (SEP)								
MN	0.000	453746.	0.	8.802	0.	0.000	453746.	0.
MX	35.303	544776.	0.	8.802	0.	35.303	544776.	0.
SM	5626.311	352958560.	0.	6337.618	0.	5626.311	352958560.	0.
AV	7.814	490220.	0.	8.802	0.	7.814	490220.	0.
MONTHLY SUMMARY (OCT)								
MN	0.000	448607.	-300623.	8.802	-468716.	0.000	448607.	-402575.
MX	19.946	520757.	0.	8.802	0.	19.946	520757.	0.
SM	4661.553	356430656.	-55228744.	6548.872	-179986928.	4661.553	356430656.	-78047264.
AV	6.266	479073.	-74232.	8.802	-241918.	6.266	479073.	-104902.
MONTHLY SUMMARY (NOV)								
MN	0.000	474122.	-200206.	8.802	-468716.	0.000	474122.	-293695.
MX	0.000	591222.	0.	8.802	-468716.	0.000	591222.	0.
SM	0.000	346902816.	-67373792.	6337.618	-337475488.	0.000	346902816.	-106014232.
AV	0.000	481809.	-93575.	8.802	-468716.	0.000	481809.	-147242.
MONTHLY SUMMARY (DEC)								
MN	0.000	474122.	-287048.	8.802	-468716.	0.000	474122.	-404393.
MX	0.000	501821.	-4046.	8.802	-468716.	0.000	501821.	-17326.
SM	0.000	353088992.	-115888240.	6548.872	-348724672.	0.000	353088992.	-174132400.
AV	0.000	474582.	-155764.	8.802	-468716.	0.000	474582.	-234049.
YEARLY SUMMARY								
MN	0.000	435174.	-341156.	8.802	-468716.	0.000	435174.	-473503.
MX	42.867	591222.	0.	8.802	0.	42.867	591222.	0.
SM	41543.422	4237593600.	-600582848.	77107.688	-2216089088.	41543.422	4237593600.	-907105984.
AV	4.742	483744.	-68560.	8.802	-252978.	4.742	483744.	-103551.

MMDDHH	AC-4	AC-4	AC-4	AC-4	AC-5	AC-5	AC-5	AC-5
	SUPPLY ELECTRIC KW	HEATING CAPACITY BTU/HR	COOLING ELECTRIC KW	COOLING CAPACITY BTU/HR	TOT HTG COIL PWR BTU/HR	SUPPLY ELECTRIC KW	HEATING CAPACITY BTU/HR	COOLING ELECTRIC KW
	----(49)	----(78)	----(47)	----(70)	----(5)	----(49)	----(78)	----(47)
MONTHLY SUMMARY (JAN)								
MN	11.755	-625927.	0.000	616037.	-151338.	3.795	-202077.	0.000
MX	11.755	-625927.	0.000	630892.	-24979.	3.795	-202077.	0.000
SM	8745.424	-465689664.	0.000	458364192.	-70745440.	2823.406	-150345056.	0.000
AV	11.755	-625927.	0.000	616081.	-95088.	3.795	-202077.	0.000
MONTHLY SUMMARY (FEB)								
MN	11.755	-625927.	0.000	616037.	-161050.	3.795	-202077.	0.000
MX	11.755	-625927.	0.000	641917.	-26223.	3.795	-202077.	0.000
SM	7899.093	-420622944.	0.000	414200352.	-67586784.	2550.173	-135795536.	0.000
AV	11.755	-625927.	0.000	616370.	-100576.	3.795	-202077.	0.000
MONTHLY SUMMARY (MAR)								
MN	11.755	-625927.	0.000	603809.	-139728.	3.795	-202077.	0.000
MX	11.755	-625927.	0.000	672252.	-13958.	3.795	-202077.	0.000
SM	8745.424	-465689664.	0.000	458754240.	-66159992.	2823.406	-150345056.	0.000
AV	11.755	-625927.	0.000	616605.	-88925.	3.795	-202077.	0.000
MONTHLY SUMMARY (APR)								
MN	11.755	-625927.	0.000	608859.	-125498.	3.795	-202077.	0.000
MX	11.755	-625927.	0.000	699285.	-1657.	3.795	-202077.	0.000
SM	8463.313	-450667424.	0.000	446353440.	-54051576.	2732.328	-145495216.	0.000
AV	11.755	-625927.	0.000	619935.	-75072.	3.795	-202077.	0.000
MONTHLY SUMMARY (MAY)								
MN	11.755	0.	0.000	565431.	0.	3.795	0.	0.000
MX	11.755	0.	24.980	694703.	0.	3.795	0.	0.000
SM	8745.424	0.	2722.962	465301408.	0.	2823.406	0.	0.000
AV	11.755	0.	3.660	625405.	0.	3.795	0.	0.000
MONTHLY SUMMARY (JUN)								
MN	11.755	0.	0.000	568540.	0.	3.795	0.	0.000
MX	11.755	0.	50.433	697583.	0.	3.795	0.	9.916
SM	8463.313	0.	9634.086	460578656.	0.	2732.328	0.	603.219
AV	11.755	0.	13.381	639693.	0.	3.795	0.	0.838
MONTHLY SUMMARY (JUL)								
MN	11.755	0.	0.000	574102.	0.	3.795	0.	0.000
MX	11.755	0.	53.904	711925.	0.	3.795	0.	12.718
SM	8745.424	0.	13488.486	486248672.	0.	2823.406	0.	1888.560
AV	11.755	0.	18.130	653560.	0.	3.795	0.	2.538

	AC-4	AC-4	AC-4	AC-4	AC-5	AC-5	AC-5	AC-5
	SUPPLY ELECTRIC KW	HEATING CAPACITY BTU/HR	COOLING ELECTRIC KW	COOLING CAPACITY BTU/HR	TOT HTG COIL PWR BTU/HR	SUPPLY ELECTRIC KW	HEATING CAPACITY BTU/HR	COOLING ELECTRIC KW
	----(49)	----(78)	----(47)	----(70)	----(5)	----(49)	----(78)	----(47)
MONTHLY SUMMARY (AUG)								
MN	11.755	0.	0.000	588694.	0.	3.795	0.	0.000
MX	11.755	0.	50.250	702324.	0.	3.795	0.	14.087
SM	8745.424	0.	12344.067	486117408.	0.	2823.406	0.	2895.442
AV	11.755	0.	16.591	653384.	0.	3.795	0.	3.892
MONTHLY SUMMARY (SEP)								
MN	11.755	0.	0.000	589258.	0.	3.795	0.	0.000
MX	11.755	0.	43.490	709242.	0.	3.795	0.	13.110
SM	8463.313	0.	6651.983	458754688.	0.	2732.328	0.	1755.637
AV	11.755	0.	9.239	637159.	0.	3.795	0.	2.438
MONTHLY SUMMARY (OCT)								
MN	11.755	-625927.	0.000	582885.	-130395.	3.795	-202077.	0.000
MX	11.755	0.	24.310	674549.	0.	3.795	0.	9.165
SM	8745.424	-240356032.	5647.898	462711744.	-23057172.	2823.406	-77597448.	1996.208
AV	11.755	-323059.	7.591	621924.	-30991.	3.795	-104298.	2.683
MONTHLY SUMMARY (NOV)								
MN	11.755	-625927.	0.000	616037.	-80705.	3.795	-202077.	0.000
MX	11.755	-625927.	0.000	761123.	-9.	3.795	-202077.	0.000
SM	8463.313	-450667424.	0.000	450266976.	-30915672.	2732.328	-145495216.	0.000
AV	11.755	-625927.	0.000	625371.	-42938.	3.795	-202077.	0.000
MONTHLY SUMMARY (DEC)								
MN	11.755	-625927.	0.000	616037.	-120830.	3.795	-202077.	0.000
MX	11.755	-625927.	0.000	647772.	-219.	3.795	-202077.	0.000
SM	8745.424	-465689664.	0.000	458731424.	-54136224.	2823.406	-150345056.	0.000
AV	11.755	-625927.	0.000	616575.	-72764.	3.795	-202077.	0.000
YEARLY SUMMARY								
MN	11.755	-625927.	0.000	565431.	-161050.	3.795	-202077.	0.000
MX	11.755	0.	53.904	761123.	0.	3.795	0.	14.087
SM	102970.305	-2959382784.	50489.484	5506383360.	-366652896.	33243.328	-955418624.	9139.067
AV	11.755	-37829.	5.764	628583.	-41855.	3.795	-109066.	1.043

MMDDHH	AC-5	AC-6	AC-6	AC-6	AC-6	AC-6	AC-7	AC-7
	COOLING CAPACITY BTU/HR	TOT HTG COIL PWR BTU/HR	SUPPLY ELECTRIC KW	HEATING CAPACITY BTU/HR	COOLING ELECTRIC KW	COOLING CAPACITY BTU/HR	TOT HTG COIL PWR BTU/HR	SUPPLY ELECTRIC KW
	---- (70)	---- (5)	---- (49)	---- (78)	---- (47)	---- (70)	---- (5)	---- (49)
MONTHLY SUMMARY (JAN)								
MN	198036.	-334123.	8.830	-470175.	0.000	477597.	-334123.	8.830
MX	201884.	-27744.	8.830	-470175.	0.000	489088.	-27744.	8.830
SM	147345296.	-135709648.	6569.260	-349810048.	0.000	355357440.	-135709648.	6569.260
AV	198045.	-182405.	8.830	-470175.	0.000	477631.	-182405.	8.830
MONTHLY SUMMARY (FEB)								
MN	198036.	-342350.	8.830	-470175.	0.000	477597.	-342350.	8.830
MX	207757.	-14.	8.830	-470175.	0.000	501530.	-14.	8.830
SM	133181640.	-113337960.	5933.525	-315957472.	0.000	321166944.	-113337960.	5933.525
AV	198187.	-168658.	8.830	-470175.	0.000	477927.	-168658.	8.830
MONTHLY SUMMARY (MAR)								
MN	194105.	-268883.	8.830	-470175.	0.000	468117.	-268883.	8.830
MX	215019.	-9.	8.830	-470175.	0.000	521239.	-9.	8.830
SM	147487632.	-82412720.	6569.260	-349810048.	0.000	355714944.	-82412720.	6569.260
AV	198236.	-110770.	8.830	-470175.	0.000	478111.	-110770.	8.830
MONTHLY SUMMARY (APR)								
MN	190175.	-225604.	8.830	-470175.	0.000	472838.	-225604.	8.830
MX	218850.	-3.	8.830	-470175.	0.000	545070.	-3.	8.830
SM	143272320.	-44775292.	6357.348	-338525856.	0.000	346228064.	-44775292.	6357.348
AV	198989.	-62188.	8.830	-470175.	0.000	480872.	-62188.	8.830
MONTHLY SUMMARY (MAY)								
MN	181768.	0.	8.830	0.	0.000	438364.	0.	8.830
MX	230919.	0.	8.830	0.	19.433	537160.	0.	8.830
SM	149338240.	0.	6569.260	0.	2144.930	360869984.	0.	6569.260
AV	200723.	0.	8.830	0.	2.883	485040.	0.	8.830
MONTHLY SUMMARY (JUN)								
MN	181768.	0.	8.830	0.	0.000	440595.	0.	8.830
MX	236347.	0.	8.830	0.	38.354	538507.	0.	8.830
SM	150643120.	0.	6357.348	0.	7441.542	357164416.	0.	6357.348
AV	209227.	0.	8.830	0.	10.335	496062.	0.	8.830
MONTHLY SUMMARY (JUL)								
MN	185147.	0.	8.830	0.	0.000	445086.	0.	8.830
MX	246939.	0.	8.830	0.	41.124	550813.	0.	8.830
SM	160566528.	0.	6569.260	0.	10398.167	377005248.	0.	6569.260
AV	215815.	0.	8.830	0.	13.976	506727.	0.	8.830

	AC-5	AC-6	AC-6	AC-6	AC-6	AC-6	AC-7	AC-7
	COOLING CAPACITY BTU/HR	TOT HTG COIL PWR BTU/HR	SUPPLY ELECTRIC KW	HEATING CAPACITY BTU/HR	COOLING ELECTRIC KW	COOLING CAPACITY BTU/HR	TOT HTG COIL PWR BTU/HR	SUPPLY ELECTRIC KW
	----(70)	----(5)	----(49)	----(78)	----(47)	----(70)	----(5)	----(49)
MONTHLY SUMMARY (AUG)								
MN	190166.	0.	8.830	0.	0.000	457812.	0.	8.830
MX	238314.	0.	8.830	0.	38.115	543877.	0.	8.830
SM	158223952.	0.	6569.260	0.	9659.878	376791744.	0.	6569.260
AV	212667.	0.	8.830	0.	12.984	506441.	0.	8.830
MONTHLY SUMMARY (SEP)								
MN	190717.	0.	8.830	0.	0.000	457764.	0.	8.830
MX	238264.	0.	8.830	0.	33.479	549293.	0.	8.830
SM	148708240.	0.	6357.348	0.	5270.334	355798688.	0.	6357.348
AV	206539.	0.	8.830	0.	7.320	494165.	0.	8.830
MONTHLY SUMMARY (OCT)								
MN	187378.	-304656.	8.830	-470175.	0.000	451895.	-304656.	8.830
MX	216871.	0.	8.830	0.	19.223	523909.	0.	8.830
SM	148874960.	-56511352.	6569.260	-180547152.	4483.261	359034624.	-56511352.	6569.260
AV	200101.	-75956.	8.830	-242671.	6.026	482573.	-75956.	8.830
MONTHLY SUMMARY (NOV)								
MN	198036.	-201460.	8.830	-470175.	0.000	477597.	-201460.	8.830
MX	244880.	-1.	8.830	-470175.	0.000	593727.	-1.	8.830
SM	144573344.	-70423856.	6357.348	-338525856.	0.000	349312128.	-70423856.	6357.348
AV	200796.	-97811.	8.830	-470175.	0.000	485156.	-97811.	8.830
MONTHLY SUMMARY (DEC)								
MN	198036.	-288938.	8.830	-470175.	0.000	477597.	-288938.	8.830
MX	210598.	-6352.	8.830	-470175.	0.000	504230.	-6352.	8.830
SM	147486336.	-119448216.	6569.260	-349810048.	0.000	355667136.	-119448216.	6569.260
AV	198234.	-160549.	8.830	-470175.	0.000	478047.	-160549.	8.830
YEARLY SUMMARY								
MN	181768.	-342350.	8.830	-470175.	0.000	438364.	-342350.	8.830
MX	246939.	0.	8.830	0.	41.124	593727.	0.	8.830
SM	1779701632.	-622619072.	77347.734	-2222986496.	39398.113	4270111488.	-622619072.	77347.734
AV	203162.	-71075.	8.830	-253766.	4.498	487456.	-71075.	8.830

MMDDHH	AC-7	AC-7	AC-7	AC-8	AC-8	AC-8	AC-8	AC-8
	HEATING CAPACITY BTU/HR	COOLING ELECTRIC KW	COOLING CAPACITY BTU/HR	TOT HTG COIL PWR BTU/HR	SUPPLY ELECTRIC KW	HEATING CAPACITY BTU/HR	COOLING ELECTRIC KW	COOLING CAPACITY BTU/HR
	----(78)	----(47)	----(70)	----(5)	----(49)	----(78)	----(47)	----(70)
MONTHLY SUMMARY (JAN)								
MN	-470175.	0.000	477597.	-473425.	11.775	-627021.	0.000	617078.
MX	-470175.	0.000	489088.	-70374.	11.775	-627021.	0.000	631946.
SM	-349810048.	0.000	355357440.	-200055008.	8760.710	-466503840.	0.000	459138208.
AV	-470175.	0.000	477631.	-268891.	11.775	-627021.	0.000	617121.
MONTHLY SUMMARY (FEB)								
MN	-470175.	0.000	477597.	-464852.	11.775	-627021.	0.000	617078.
MX	-470175.	0.000	501530.	-15.	11.775	-627021.	0.000	641444.
SM	-315957472.	0.000	321166944.	-165388224.	7912.899	-421358304.	0.000	414890496.
AV	-470175.	0.000	477927.	-246113.	11.775	-627021.	0.000	617397.
MONTHLY SUMMARY (MAR)								
MN	-470175.	0.000	468117.	-370359.	11.775	-627021.	0.000	603579.
MX	-470175.	0.000	521239.	-9.	11.775	-627021.	0.000	673336.
SM	-349810048.	0.000	355714944.	-126114232.	8760.710	-466503840.	0.000	459515264.
AV	-470175.	0.000	478111.	-169508.	11.775	-627021.	0.000	617628.
MONTHLY SUMMARY (APR)								
MN	-470175.	0.000	472838.	-318079.	11.775	-627021.	0.000	608210.
MX	-470175.	0.000	545070.	-3.	11.775	-627021.	0.000	697726.
SM	-338525856.	0.000	346228064.	-71968352.	8478.106	-451455328.	0.000	446996448.
AV	-470175.	0.000	480872.	-99956.	11.775	-627021.	0.000	620828.
MONTHLY SUMMARY (MAY)								
MN	0.	0.000	438364.	0.	11.775	0.	0.000	566386.
MX	0.	19.433	537160.	0.	11.775	0.	23.571	696661.
SM	0.	2144.930	360869984.	0.	8760.710	0.	2473.110	466177600.
AV	0.	2.883	485040.	0.	11.775	0.	3.324	626583.
MONTHLY SUMMARY (JUN)								
MN	0.	0.000	440595.	0.	11.775	0.	0.000	569440.
MX	0.	38.354	538507.	0.	11.775	0.	48.477	699428.
SM	0.	7441.542	357164416.	0.	8478.106	0.	9171.695	461792160.
AV	0.	10.335	496062.	0.	11.775	0.	12.738	641378.
MONTHLY SUMMARY (JUL)								
MN	0.	0.000	445086.	0.	11.775	0.	0.000	575072.
MX	0.	41.124	550813.	0.	11.775	0.	52.012	713729.
SM	0.	10398.167	377005248.	0.	8760.710	0.	13008.088	487654464.
AV	0.	13.976	506727.	0.	11.775	0.	17.484	655450.

	AC-7	AC-7	AC-7	AC-8	AC-8	AC-8	AC-8	AC-8
	HEATING CAPACITY BTU/HR	COOLING ELECTRIC KW	COOLING CAPACITY BTU/HR	TOT HTG COIL PWR BTU/HR	SUPPLY ELECTRIC KW	HEATING CAPACITY BTU/HR	COOLING ELECTRIC KW	COOLING CAPACITY BTU/HR
	----(78)	----(47)	----(70)	----(5)	----(49)	----(78)	----(47)	----(70)
MONTHLY SUMMARY (AUG)								
MN	0.	0.000	457812.	0.	11.775	0.	0.000	589908.
MX	0.	38.115	543877.	0.	11.775	0.	48.147	703999.
SM	0.	9659.878	376791744.	0.	8760.710	0.	11822.164	487571840.
AV	0.	12.984	506441.	0.	11.775	0.	15.890	655339.
MONTHLY SUMMARY (SEP)								
MN	0.	0.000	457764.	0.	11.775	0.	0.000	591671.
MX	0.	33.479	549293.	0.	11.775	0.	41.592	711002.
SM	0.	5270.334	355798688.	0.	8478.106	0.	6273.565	459810272.
AV	0.	7.320	494165.	0.	11.775	0.	8.713	638625.
MONTHLY SUMMARY (OCT)								
MN	-470175.	0.000	451895.	-406012.	11.775	-627021.	0.000	583869.
MX	0.	19.223	523909.	0.	11.775	0.	23.593	675022.
SM	-180547152.	4483.261	359034624.	-79280928.	8760.710	-240776176.	5462.807	463473344.
AV	-242671.	6.026	482573.	-106560.	11.775	-323624.	7.342	622948.
MONTHLY SUMMARY (NOV)								
MN	-470175.	0.000	477597.	-295178.	11.775	-627021.	0.000	617078.
MX	-470175.	0.000	593727.	-1.	11.775	-627021.	0.000	760432.
SM	-338525856.	0.000	349312128.	-109223664.	8478.106	-451455328.	0.000	450905504.
AV	-470175.	0.000	485156.	-151700.	11.775	-627021.	0.000	626258.
MONTHLY SUMMARY (DEC)								
MN	-470175.	0.000	477597.	-406084.	11.775	-627021.	0.000	617078.
MX	-470175.	0.000	504230.	-22227.	11.775	-627021.	0.000	648785.
SM	-349810048.	0.000	355667136.	-177660432.	8760.710	-466503840.	0.000	459501568.
AV	-470175.	0.000	478047.	-238791.	11.775	-627021.	0.000	617610.
YEARLY SUMMARY								
MN	-470175.	0.000	438364.	-473425.	11.775	-627021.	0.000	566386.
MX	0.	41.124	593727.	0.	11.775	0.	52.012	760432.
SM	-2222986496.	39398.113	4270111488.	-929690880.	103150.305	-2964556800.	48211.434	5517427200.
AV	-253766.	4.498	487456.	-106129.	11.775	-338420.	5.504	629843.

S I T E E N E R G Y														* SOURCE
	2	3	4	5	6	7	8	9	10	11	12	13	14	
MONTH	TOTAL HEAT LOAD	TOTAL COOLING LOAD	TOTAL ELECTR LOAD	RCVRED ENERGY	WASTED RCVRABL ENERGY	FUEL INPUT COOLING	ELEC INPUT COOLING	FUEL INPUT HEATING	ELEC INPUT HEATING	FUEL INPUT ELECT	TOTAL FUEL INPUT	TOTAL SITE ENERGY	TOTAL SOURCE ENERGY	
JAN	1086.2	0.0	430.8 126.2E	0.0	0.0	0.0	0.0 0.0E	1471.8	47.4 13.9E	0.0	1471.8	1902.6	* 2765.4	*
FEB	920.6	0.0	389.7 114.1E	0.0	0.0	0.0	0.0 0.0E	1264.0	43.2 12.6E	0.0	1264.0	1653.7	* 2434.4	*
MAR	714.7	0.0	442.4 129.6E	0.0	0.0	0.0	0.0 0.0E	1017.4	41.9 12.3E	0.0	1017.4	1459.9	* 2346.1	*
APR	434.2	0.0	410.4 120.2E	0.0	0.0	0.0	0.0 0.0E	648.7	33.5 9.8E	0.0	648.7	1059.1	* 1881.0	*
MAY	0.0	0.0	432.1 126.5E	0.0	0.0	0.0	0.0 0.0E	0.0	0.0 0.0E	0.0	0.0	432.1	* 1297.5	*
JUN	0.0	0.0	558.3 163.5E	0.0	0.0	0.0	0.0 0.0E	0.0	0.0 0.0E	0.0	0.0	558.3	* 1676.5	*
JUL	0.0	0.0	623.2 182.5E	0.0	0.0	0.0	0.0 0.0E	0.0	0.0 0.0E	0.0	0.0	623.2	* 1871.6	*
AUG	0.0	0.0	638.2 186.9E	0.0	0.0	0.0	0.0 0.0E	0.0	0.0 0.0E	0.0	0.0	638.2	* 1916.4	*
SEP	0.0	0.0	507.4 148.6E	0.0	0.0	0.0	0.0 0.0E	0.0	0.0 0.0E	0.0	0.0	507.4	* 1523.6	*
OCT	433.5	0.0	512.7 150.1E	0.0	0.0	0.0	0.0 0.0E	613.3	23.9 7.0E	0.0	613.3	1126.0	* 2152.9	*
NOV	565.1	0.0	406.0 118.9E	0.0	0.0	0.0	0.0 0.0E	824.4	37.8 11.1E	0.0	824.4	1230.5	* 2043.7	*
DEC	943.5	0.0	428.8 125.6E	0.0	0.0	0.0	0.0 0.0E	1300.2	45.4 13.3E	0.0	1300.2	1729.0	* 2587.9	*
*****	*****	*****	*****	*****	*****	*****	*****	*****	*****	*****	*****	*****	*****	*****
	5097.9	0.0	5779.9 1692.8E	0.0	0.0	0.0	0.0 0.0E	7139.9	273.1 80.0E	0.0	7139.9	12919.8	* 24497.1	*

NOTE-- ALL ENTRIES ARE IN MBTU EXCEPT
 ENTRIES FOLLOWED BY E ARE IN MWH (THOUSANDS OF KWH)

ENTECH ENGINEERING
 READING, PA 19603
 REPORT- PS-B MONTHLY PEAK AND TOTAL ENERGY USE

EZDOR - ELITE SOFTWARE DEVELOPMENT INC
 FT. GEORGE G. MEADE

DOB-2.1D 6/ 7/1996 10:25:58 PDL RUN 1
 EMCS FEASIBILITY STUDY
 WEATHER FILE- BALTIMORE, MD

MO	UTILITY-	ELECTRICITY	FUEL-OIL
	TOTAL (MBTU)	430.755	1471.829
JAN	PEAK (KBTU)	1116.556	3595.523
	DY/HR	31/17	31/ 6
	TOTAL (MBTU)	389.741	1263.975
FEB	PEAK (KBTU)	1116.556	3590.985
	DY/HR	28/ 7	12/13
	TOTAL (MBTU)	442.439	1017.438
MAR	PEAK (KBTU)	1116.556	2670.310
	DY/HR	31/12	5/ 8
	TOTAL (MBTU)	410.366	648.700
APR	PEAK (KBTU)	1116.556	2354.044
	DY/HR	28/ 7	9/ 8
	TOTAL (MBTU)	432.074	0.000
MAY	PEAK (KBTU)	1494.983	0.000
	DY/HR	26/16	31/ 1
	TOTAL (MBTU)	558.279	0.000
JUN	PEAK (KBTU)	1996.079	0.000
	DY/HR	29/16	30/ 1
	TOTAL (MBTU)	623.248	0.000
JUL	PEAK (KBTU)	2076.234	0.000
	DY/HR	25/16	31/ 1
	TOTAL (MBTU)	638.159	0.000
AUG	PEAK (KBTU)	2019.660	0.000
	DY/HR	18/17	31/ 1
	TOTAL (MBTU)	507.368	0.000
SEP	PEAK (KBTU)	1903.912	0.000
	DY/HR	2/14	30/ 1
	TOTAL (MBTU)	512.676	613.314
OCT	PEAK (KBTU)	1597.952	2891.815
	DY/HR	31/14	16/ 2
	TOTAL (MBTU)	406.010	824.445
NOV	PEAK (KBTU)	1116.556	2099.783
	DY/HR	30/ 9	23/ 6
	TOTAL (MBTU)	428.810	1300.226
DEC	PEAK (KBTU)	1116.556	2792.993
	DY/HR	30/ 8	22/ 5
	ONE YEAR	5779.924	7139.927
	USE/PEAK	2076.234	3595.523

ENTECH ENGINEERING
READING, PA 19603
REPORT- PS-D PLANT LOADS SATISFIED

EZDOE - ELITE SOFTWARE DEVELOPMENT INC
FT. GEORGE G. MEADE

DOB-2.1D 6/ 7/1996 10:25:58 PDL RUN 1
EMCS FEASIBILITY STUDY
WEATHER FILE- BALTIMORE, MD

HEATING LOADS	MBTU SUPPLIED	PCT OF TOTAL LOAD
-----	-----	-----
HW-BOILER	5097.9	100.0
	=====	=====
LOAD SATISFIED	5097.9	100.0
TOTAL LOAD ON PLANT	5097.9	
ELECTRICAL LOADS	MBTU SUPPLIED	PCT OF TOTAL LOAD
-----	-----	-----
ELECTRICITY	5779.9	100.0
	=====	=====
LOAD SATISFIED	5779.9	100.0
TOTAL LOAD ON PLANT	5779.7	

ENTECH ENGINEERING
READING, PA 19603
REPORT- PS-D PLANT LOADS SATISFIED

EZDOE - ELITE SOFTWARE DEVELOPMENT INC
FT. GEORGE G. MEADE

DOE-2.1D 6/ 7/1996 10:25:58 PDL RUN 1
EMCS FEASIBILITY STUDY
WEATHER FILE- BALTIMORE, MD
----- (CONTINUED) -----

SUMMARY OF LOADS MET

TYPE OF LOAD	TOTAL LOAD (MBTU)	LOAD SATISFIED (MBTU)	TOTAL OVERLOAD (MBTU)	PEAK OVERLOAD (MBTU)	HOURS OVERLOADED
HEATING LOADS	5097.9	5097.9	0.000	0.000	0
ELECTRICAL LOADS	5779.7	5779.9	0.000	0.000	0

ENTECH ENGINEERING
READING, PA 19603
REPORT- PS-H EQUIPMENT USE STATISTICS

EZDOE - ELITE SOFTWARE DEVELOPMENT INC
FT. GEORGE G. MEADE

DOB-2.1D 6/ 7/1996 10:25:58 PDL RUN 1
EMCS FEASIBILITY STUDY
WEATHER FILE- BALTIMORE, MD

EQUIPMENT	AVG	MAX	MON		SIZE OPER		SIZE OPER		SIZE OPER		SIZE OPER	
	OPER	LOAD	DAY	HR	(MBTU)	HRS	(MBTU)	HRS	(MBTU)	HRS	(MBTU)	HRS
-----	RATIO	(MBTU)	-----	-----	-----	-----	-----	-----	-----	-----	-----	-----
HW-BOILER	0.443	2.600	1	31	6	2.400	4798					

E Q U I P M E N T T O T A L S

HW-BOILER		137.1		
	NOMINAL SIZE (MBTU)		2.400	
	NUMBER INSTALLED		2	
	FIRST COST (K\$)	127.5	127.5	
	ANNUAL COST (K\$)	4.1	4.1	
	CYCLICAL COST (K\$)	5.4	5.4	
	-----TOTAL----- (K\$)		137.1	
<hr/>				
EQUIPMENT TOTAL		137.1		

ENERGY TYPE	ELECTRICITY	FUEL-OIL
IN SITE MBTU -		
CATEGORY OF USE		
SPACE HEAT	227.78	7139.93
SPACE COOL	952.18	0.00
HVAC AUX	2030.81	0.00
DOM HOT WTR	0.00	0.00
AUX SOLAR	0.00	0.00
LIGHTS	1701.41	0.00
VERT TRANS	0.00	0.00
MISC EQUIP	867.92	0.00
TOTAL	5780.11	7139.93

TOTAL SITE ENERGY 12919.85 MBTU 144.3 KBTU/SQFT-YR GROSS-AREA 144.3 KBTU/SQFT-YR NET-AREA
 TOTAL SOURCE ENERGY 24497.06 MBTU 273.6 KBTU/SQFT-YR GROSS-AREA 273.6 KBTU/SQFT-YR NET-AREA

PERCENT OF HOURS ANY SYSTEM ZONE OUTSIDE OF THROTTLING RANGE = 20.6
 PERCENT OF HOURS ANY PLANT LOAD NOT SATISFIED = 0.0

NOTE ELECTRICITY AND/OR FUEL USED TO GENERATE ELECTRICITY IS APPORTIONED BASED
 ON THE YEARLY DEMAND. ALL OTHER ENERGY TYPES ARE APPORTIONED HOURLY.

 MMDDHH HW-BOILE HW-BOILE HW-BOILE
 R R R
 LOAD ELECTRIC FUEL
 USE USE
 BTU/HR BTU/HR BTU/HR

----(1) ----(3) ----(4)

MONTHLY SUMMARY (JAN)

MN	297386.	26170.	485970.
MX	2600146.	105600.	3595523.
SM	1086213504.	40254284.	1471829120.
AV	1459964.	54105.	1978265.

MONTHLY SUMMARY (FEB)

MN	72976.	6422.	119253.
MX	2596161.	105600.	3590985.
SM	920606912.	36752576.	1263973376.
AV	1369951.	54691.	1880913.

MONTHLY SUMMARY (MAR)

MN	45176.	3976.	73825.
MX	2089090.	52800.	2670310.
SM	714741376.	34743968.	1017438272.
AV	960674.	46699.	1367525.

MONTHLY SUMMARY (APR)

MN	20540.	1807.	33565.
MX	1797681.	52800.	2354044.
SM	434179968.	26636678.	648700608.
AV	603028.	36995.	900973.

MONTHLY SUMMARY (OCT)

MN	495675.	43619.	810002.
MX	2297144.	52800.	2891815.
SM	433530848.	20201782.	613313664.
AV	1128987.	52609.	1597171.

MONTHLY SUMMARY (NOV)

MN	17227.	1516.	28152.
MX	1567963.	52800.	2099783.
SM	565054720.	30879306.	824445056.
AV	784798.	42888.	1145063.

MONTHLY SUMMARY (DEC)

MN	77996.	6864.	127456.
MX	2203908.	52800.	2792993.
SM	943541376.	38308968.	1300225920.
AV	1268201.	51491.	1747616.

ENTECH ENGINEERING
READING, PA 19603
PH-1 = HOURLY-REPORT

EZDOE - ELITE SOFTWARE DEVELOPMENT INC
FT. GEORGE G. MEADE

DOB-2.1D 6/7/1996 10:25:58 PDL RUN 1
EMCS FEASIBILITY STUDY

HW-BOILE HW-BOILE HW-BOILE
R R R
LOAD ELECTRIC FUEL
 USE USE
BTU/HR BTU/HR BTU/HR

---- (1) ---- (3) ---- (4)

YEARLY SUMMARY

MN	17227.	1516.	28152.
MX	2600146.	105600.	3595523.
SM	5097868800.	227777568.	7139925504.
AV	1078230.	48176.	1510137.

MMDDRH	AC-1	AC-1	AC-1	AC-1	AC-1	AC-2	AC-2	AC-2
	TOT HTG COIL PWR BTU/HR	SUPPLY ELECTRIC KW	HEATING CAPACITY BTU/HR	COOLING ELECTRIC KW	COOLING CAPACITY BTU/HR	TOT HTG COIL PWR BTU/HR	SUPPLY ELECTRIC KW	HEATING CAPACITY BTU/HR
	---- (5)	---- (49)	---- (78)	---- (47)	---- (70)	---- (5)	---- (49)	---- (78)
MONTHLY SUMMARY (JAN)								
MN	-133650.	2.870	-132355.	0.000	150178.	-314104.	6.928	-319433.
MX	-27606.	2.870	-132355.	0.000	150178.	-20733.	6.928	-319433.
SM	-20428316.	723.341	-33353338.	0.000	37844976.	-37355384.	1745.755	-80497016.
AV	-81065.	2.870	-132355.	0.000	150178.	-148236.	6.928	-319433.
MONTHLY SUMMARY (FEB)								
MN	-130071.	2.870	-132355.	0.000	150178.	-305067.	6.928	-319433.
MX	-33010.	2.870	-132355.	0.000	155334.	-485.	6.928	-319433.
SM	-20454636.	654.451	-30176830.	0.000	34275444.	-28396304.	1579.493	-72830632.
AV	-89713.	2.870	-132355.	0.000	150331.	-124545.	6.928	-319433.
MONTHLY SUMMARY (MAR)								
MN	-130226.	2.870	-132355.	0.000	146460.	-273209.	6.928	-319433.
MX	-30431.	2.870	-132355.	0.000	160382.	-12.	6.928	-319433.
SM	-22867458.	792.231	-36529848.	0.000	41478140.	-17063330.	1912.018	-88163400.
AV	-82853.	2.870	-132355.	0.000	150283.	-61824.	6.928	-319433.
MONTHLY SUMMARY (APR)								
MN	-127577.	2.870	-132355.	0.000	142096.	-214810.	6.928	-319433.
MX	-16147.	2.870	-132355.	0.000	164360.	-3.	6.928	-319433.
SM	-17287666.	723.341	-33353338.	0.000	38048544.	-5198911.	1745.755	-80497016.
AV	-68602.	2.870	-132355.	0.000	150986.	-20631.	6.928	-319433.
MONTHLY SUMMARY (MAY)								
MN	0.	2.870	0.	0.000	137842.	0.	6.928	0.
MX	0.	2.870	0.	0.000	176416.	0.	6.928	0.
SM	0.	723.341	0.	0.000	38800216.	0.	1745.755	0.
AV	0.	2.870	0.	0.000	153969.	0.	6.928	0.
MONTHLY SUMMARY (JUN)								
MN	0.	2.870	0.	0.000	139301.	0.	6.928	0.
MX	0.	2.870	0.	7.880	180421.	0.	6.928	0.
SM	0.	757.786	0.	382.105	42230360.	0.	1828.887	0.
AV	0.	2.870	0.	1.447	159963.	0.	6.928	0.
MONTHLY SUMMARY (JUL)								
MN	0.	2.870	0.	0.000	141380.	0.	6.928	0.
MX	0.	2.870	0.	10.886	187940.	0.	6.928	0.
SM	0.	688.896	0.	1357.446	38042468.	0.	1662.624	0.
AV	0.	2.870	0.	5.656	158510.	0.	6.928	0.

	AC-1	AC-1	AC-1	AC-1	AC-1	AC-2	AC-2	AC-2
	TOT HTG COIL PWR BTU/HR	SUPPLY ELECTRIC KW	HEATING CAPACITY BTU/HR	COOLING ELECTRIC KW	COOLING CAPACITY BTU/HR	TOT HTG COIL PWR BTU/HR	SUPPLY ELECTRIC KW	HEATING CAPACITY BTU/HR
	----(5)	----(49)	----(78)	----(47)	----(70)	----(5)	----(49)	----(78)
MONTHLY SUMMARY (AUG)								
MN	0.	2.870	0.	0.000	144382.	0.	6.928	0.
MK	0.	2.870	0.	12.760	173477.	0.	6.928	0.
SM	0.	792.231	0.	2003.170	42872276.	0.	1912.018	0.
AV	0.	2.870	0.	7.258	155334.	0.	6.928	0.
MONTHLY SUMMARY (SEP)								
MN	0.	2.870	0.	0.000	143663.	0.	6.928	0.
MK	0.	2.870	0.	12.105	165886.	0.	6.928	0.
SM	0.	723.341	0.	1295.228	38757168.	0.	1745.755	0.
AV	0.	2.870	0.	5.140	153798.	0.	6.928	0.
MONTHLY SUMMARY (OCT)								
MN	-60008.	2.870	-132355.	0.000	147236.	-221809.	6.928	-319433.
MK	0.	2.870	0.	8.125	166510.	0.	6.928	0.
SM	-2211798.	688.896	-17470798.	882.075	36522808.	-10389455.	1662.624	-42165096.
AV	-9216.	2.870	-72795.	3.675	152178.	-43289.	6.928	-175688.
MONTHLY SUMMARY (NOV)								
MN	-121027.	2.870	-132355.	0.000	150178.	-269811.	6.928	-319433.
MK	-12.	2.870	-132355.	0.000	184821.	-1.	6.928	-319433.
SM	-3265774.	688.896	-31765084.	0.000	36867512.	-13983178.	1662.624	-76663824.
AV	-13607.	2.870	-132355.	0.000	153615.	-58263.	6.928	-319433.
MONTHLY SUMMARY (DEC)								
MN	-129361.	2.870	-132355.	0.000	150178.	-281584.	6.928	-319433.
MK	-1926.	2.870	-132355.	0.000	158205.	-6616.	6.928	-319433.
SM	-12077275.	723.341	-33353338.	0.000	37887540.	-31541000.	1745.755	-80497016.
AV	-47926.	2.870	-132355.	0.000	150347.	-125163.	6.928	-319433.
YEARLY SUMMARY								
MN	-133650.	2.870	-132355.	0.000	137842.	-314104.	6.928	-319433.
MK	0.	2.870	0.	12.760	187940.	0.	6.928	0.
SM	-98592920.	8680.091	-216002576.	5920.024	463627520.	-143927552.	20949.066	-521313984.
AV	-32603.	2.870	-71429.	1.958	153316.	-47595.	6.928	-172392.

MMDDHH	AC-2	AC-2	AC-3	AC-3	AC-3	AC-3	AC-3	AC-3	AC-4
	COOLING ELECTRIC KW	COOLING CAPACITY BTU/HR	TOT HTG COIL PWR BTU/HR	SUPPLY ELECTRIC KW	HEATING CAPACITY BTU/HR	COOLING ELECTRIC KW	COOLING CAPACITY BTU/HR	TOT HTG COIL PWR BTU/HR	
	----	----	----	----	----	----	----	----	
	(47)	(70)	(5)	(49)	(78)	(47)	(70)	(5)	
MONTHLY SUMMARY (JAN)									
MN	0.000	375976.	-313874.	6.877	-319214.	0.000	376161.	-403567.	
MX	0.000	375976.	-20583.	6.877	-319214.	0.000	376161.	-57483.	
SM	0.000	94746072.	-37300936.	1733.105	-80441872.	0.000	94792648.	-57176852.	
AV	0.000	375976.	-148020.	6.877	-319214.	0.000	376161.	-226892.	
MONTHLY SUMMARY (FEB)									
MN	0.000	375976.	-304840.	6.877	-319214.	0.000	376161.	-398589.	
MX	0.000	387299.	-447.	6.877	-319214.	0.000	387539.	-3414.	
SM	0.000	85793408.	-28348826.	1568.047	-72780736.	0.000	85836168.	-43286748.	
AV	0.000	376287.	-124337.	6.877	-319214.	0.000	376474.	-189854.	
MONTHLY SUMMARY (MAR)									
MN	0.000	366666.	-272976.	6.877	-319214.	0.000	366847.	-362706.	
MX	0.000	397330.	-12.	6.877	-319214.	0.000	397574.	-13.	
SM	0.000	103841104.	-17017280.	1898.163	-88103008.	0.000	103892992.	-30763982.	
AV	0.000	376236.	-61657.	6.877	-319214.	0.000	376424.	-111464.	
MONTHLY SUMMARY (APR)									
MN	0.000	372230.	-214545.	6.877	-319214.	0.000	372413.	-282415.	
MX	0.000	431727.	-3.	6.877	-319214.	0.000	432021.	-5.	
SM	0.000	95813120.	-5178695.	1733.105	-80441872.	0.000	95864752.	-11319634.	
AV	0.000	380211.	-20550.	6.877	-319214.	0.000	380416.	-44919.	
MONTHLY SUMMARY (MAY)									
MN	0.000	345091.	0.	6.877	0.	0.000	345260.	0.	
MX	20.182	409373.	0.	6.877	0.	20.204	409624.	0.	
SM	1618.944	96344504.	0.	1733.105	0.	1631.664	96386016.	0.	
AV	6.424	382319.	0.	6.877	0.	6.475	382484.	0.	
MONTHLY SUMMARY (JUN)									
MN	0.000	350275.	0.	6.877	0.	0.000	350477.	0.	
MX	38.193	420919.	0.	6.877	0.	38.215	421168.	0.	
SM	4897.615	101714488.	0.	1815.634	0.	4920.183	101759480.	0.	
AV	18.552	385282.	0.	6.877	0.	18.637	385453.	0.	
MONTHLY SUMMARY (JUL)									
MN	8.806	352604.	0.	6.877	0.	8.820	352817.	0.	
MX	39.545	414140.	0.	6.877	0.	39.564	414377.	0.	
SM	6020.360	92999416.	0.	1650.576	0.	6025.262	93052560.	0.	
AV	25.085	387498.	0.	6.877	0.	25.105	387719.	0.	

	AC-2	AC-2	AC-3	AC-3	AC-3	AC-3	AC-3	AC-4
	COOLING ELECTRIC KW	COOLING CAPACITY BTU/HR	TOT HTG COIL PWR BTU/HR	SUPPLY ELECTRIC KW	HEATING CAPACITY BTU/HR	COOLING ELECTRIC KW	COOLING CAPACITY BTU/HR	TOT HTG COIL PWR BTU/HR
	---- (47)	---- (70)	---- (5)	---- (49)	---- (78)	---- (47)	---- (70)	---- (5)
MONTHLY SUMMARY (AUG)								
MN	0.000	359724.	0.	6.877	0.	0.000	359932.	0.
MX	37.540	411467.	0.	6.877	0.	37.562	411699.	0.
SM	6497.212	106469696.	0.	1898.163	0.	6502.805	106530608.	0.
AV	23.541	385760.	0.	6.877	0.	23.561	385980.	0.
MONTHLY SUMMARY (SEP)								
MN	0.000	358749.	0.	6.877	0.	0.000	358953.	0.
MX	35.846	410903.	0.	6.877	0.	35.868	411147.	0.
SM	3639.147	96469880.	0.	1733.105	0.	3649.391	96523600.	0.
AV	14.441	382817.	0.	6.877	0.	14.482	383030.	0.
MONTHLY SUMMARY (OCT)								
MN	0.000	364682.	-221455.	6.877	-319214.	0.000	364907.	-297466.
MX	18.003	411277.	0.	6.877	0.	18.026	411523.	0.
SM	1905.056	91184528.	-10377150.	1650.576	-42136220.	1910.074	91231128.	-16466569.
AV	7.938	379936.	-43238.	6.877	-175568.	7.959	380130.	-68611.
MONTHLY SUMMARY (NOV)								
MN	0.000	375976.	-269582.	6.877	-319214.	0.000	376161.	-346531.
MX	0.000	467955.	-1.	6.877	-319214.	0.000	468252.	-2.
SM	0.000	92624728.	-13948339.	1650.576	-76611304.	0.000	92673528.	-24895024.
AV	0.000	385936.	-58118.	6.877	-319214.	0.000	386140.	-103729.
MONTHLY SUMMARY (DEC)								
MN	0.000	375976.	-281357.	6.877	-319214.	0.000	376161.	-372104.
MX	0.000	391705.	-6546.	6.877	-319214.	0.000	391948.	-23399.
SM	0.000	94818304.	-31487888.	1733.105	-80441872.	0.000	94865384.	-49457452.
AV	0.000	376263.	-124952.	6.877	-319214.	0.000	376450.	-196260.
YEARLY SUMMARY								
MN	0.000	345091.	-313874.	6.877	-319214.	0.000	345260.	-403567.
MX	39.545	467955.	0.	6.877	0.	39.564	468252.	0.
SM	24578.334	1152819200.	-143659104.	20797.262	-520956864.	24639.379	1153408768.	-233366272.
AV	8.128	381223.	-47506.	6.877	-172274.	8.148	381418.	-77171.

MMDH	AC-4	AC-4	AC-4	AC-4	AC-5	AC-5	AC-5	AC-5
	SUPPLY ELECTRIC KW	HEATING CAPACITY BTU/HR	COOLING ELECTRIC KW	COOLING CAPACITY BTU/HR	TOT HTG COIL PWR BTU/HR	SUPPLY ELECTRIC KW	HEATING CAPACITY BTU/HR	COOLING ELECTRIC KW
	----(49)	----(78)	----(47)	----(70)	----(5)	----(49)	----(78)	----(47)
MONTHLY SUMMARY (JAN)								
MN	8.843	-410463.	0.000	468582.	-133554.	2.850	-132264.	0.000
MK	8.843	-410463.	0.000	468582.	-27527.	2.850	-132264.	0.000
SM	2228.525	-103436760.	0.000	118082792.	-20405444.	718.099	-33330526.	0.000
AV	8.843	-410463.	0.000	468583.	-80974.	2.850	-132264.	0.000
MONTHLY SUMMARY (FEB)								
MN	8.843	-410463.	0.000	468582.	-129976.	2.850	-132264.	0.000
MK	8.843	-410463.	0.000	479094.	-32929.	2.850	-132264.	0.000
SM	2016.284	-93585640.	0.000	106884928.	-20433656.	649.709	-30156190.	0.000
AV	8.843	-410463.	0.000	468794.	-89621.	2.850	-132264.	0.000
MONTHLY SUMMARY (MAR)								
MN	8.843	-410463.	0.000	456979.	-130131.	2.850	-132264.	0.000
MK	8.843	-410463.	0.000	492364.	-30352.	2.850	-132264.	0.000
SM	2440.765	-113287880.	0.000	129366432.	-22842224.	786.490	-36504860.	0.000
AV	8.843	-410463.	0.000	468719.	-82762.	2.850	-132264.	0.000
MONTHLY SUMMARY (APR)								
MN	8.843	-410463.	0.000	461592.	-127480.	2.850	-132264.	0.000
MK	8.843	-410463.	0.000	531614.	-16072.	2.850	-132264.	0.000
SM	2228.525	-103436760.	0.000	119018176.	-17265088.	718.099	-33330526.	0.000
AV	8.843	-410463.	0.000	472294.	-68512.	2.850	-132264.	0.000
MONTHLY SUMMARY (MAY)								
MN	8.843	0.	0.000	430089.	0.	2.850	0.	0.000
MK	8.843	0.	23.145	510446.	0.	2.850	0.	0.000
SM	2228.525	0.	1668.311	119946688.	0.	718.099	0.	0.000
AV	8.843	0.	6.620	475979.	0.	2.850	0.	0.000
MONTHLY SUMMARY (JUN)								
MN	8.843	0.	0.000	436685.	0.	2.850	0.	0.000
MK	8.843	0.	46.958	520498.	0.	2.850	0.	7.899
SM	2334.645	0.	5662.924	126590464.	0.	752.294	0.	385.539
AV	8.843	0.	21.450	479509.	0.	2.850	0.	1.460
MONTHLY SUMMARY (JUL)								
MN	8.843	0.	8.072	437104.	0.	2.850	0.	0.000
MK	8.843	0.	49.159	518362.	0.	2.850	0.	10.901
SM	2122.405	0.	6961.441	115865576.	0.	683.904	0.	1360.799
AV	8.843	0.	29.006	482773.	0.	2.850	0.	5.670

	AC-4	AC-4	AC-4	AC-4	AC-5	AC-5	AC-5	AC-5
	SUPPLY ELECTRIC KW	HEATING CAPACITY BTU/HR	COOLING ELECTRIC KW	COOLING CAPACITY BTU/HR	TOT HTG COIL PWR BTU/HR	SUPPLY ELECTRIC KW	HEATING CAPACITY BTU/HR	COOLING ELECTRIC KW
	----(49)	----(78)	----(47)	----(70)	----(5)	----(49)	----(78)	----(47)
MONTHLY SUMMARY (AUG)								
MN	8.843	0.	0.000	447082.	0.	2.850	0.	0.000
MK	8.843	0.	46.128	515502.	0.	2.850	0.	12.772
SM	2440.765	0.	7479.360	132667192.	0.	786.490	0.	2006.537
AV	8.843	0.	27.099	480678.	0.	2.850	0.	7.270
MONTHLY SUMMARY (SEP)								
MN	8.843	0.	0.000	446199.	0.	2.850	0.	0.000
MK	8.843	0.	43.475	506645.	0.	2.850	0.	12.116
SM	2228.525	0.	4023.327	120024824.	0.	718.099	0.	1299.837
AV	8.843	0.	15.966	476289.	0.	2.850	0.	5.158
MONTHLY SUMMARY (OCT)								
MN	8.843	-410463.	0.000	450767.	-59951.	2.850	-132264.	0.000
MK	8.843	0.	19.919	508393.	0.	2.850	0.	8.133
SM	2122.405	-54181160.	2066.478	113459152.	-2208613.	683.904	-17458846.	883.697
AV	8.843	-225755.	8.610	472746.	-9203.	2.850	-72745.	3.682
MONTHLY SUMMARY (NOV)								
MN	8.843	-410463.	0.000	468582.	-120932.	2.850	-132264.	0.000
MK	8.843	-410463.	0.000	577829.	-12.	2.850	-132264.	0.000
SM	2122.405	-98511200.	0.000	115172936.	-3255705.	683.904	-31743358.	0.000
AV	8.843	-410463.	0.000	479887.	-13565.	2.850	-132264.	0.000
MONTHLY SUMMARY (DEC)								
MN	8.843	-410463.	0.000	468582.	-129266.	2.850	-132264.	0.000
MK	8.843	-410463.	0.000	483814.	-1827.	2.850	-132264.	0.000
SM	2228.525	-103436760.	0.000	118140872.	-12055070.	718.099	-33330526.	0.000
AV	8.843	-410463.	0.000	468813.	-47838.	2.850	-132264.	0.000
YEARLY SUMMARY								
MN	8.843	-410463.	0.000	430089.	-133554.	2.850	-132264.	0.000
MK	8.843	0.	49.159	577829.	0.	2.850	0.	12.772
SM	26742.297	-669876160.	27861.840	1435220224.	-98465808.	8617.189	-215854832.	5936.410
AV	8.843	-221520.	9.214	474610.	-32561.	2.850	-71381.	1.963

MDDHH	AC-5	AC-6	AC-6	AC-6	AC-6	AC-6	AC-7	AC-7
	COOLING CAPACITY BTU/HR	TOT HTG COIL PWR BTU/HR	SUPPLY ELECTRIC KW	HEATING CAPACITY BTU/HR	COOLING ELECTRIC KW	COOLING CAPACITY BTU/HR	TOT HTG COIL PWR BTU/HR	SUPPLY ELECTRIC KW
	----(70)	----(5)	----(49)	----(78)	----(47)	----(70)	----(5)	----(49)
MONTHLY SUMMARY (JAN)								
MN	150255.	-302376.	6.617	-307132.	0.000	364832.	-302376.	6.617
MX	150255.	-26156.	6.617	-307132.	0.000	364832.	-26156.	6.617
SM	37864352.	-39482188.	1667.510	-77397320.	0.000	91937720.	-39482188.	1667.510
AV	150255.	-156675.	6.617	-307132.	0.000	364832.	-156675.	6.617
MONTHLY SUMMARY (FEB)								
MN	150255.	-299192.	6.617	-307132.	0.000	364832.	-299192.	6.617
MX	155430.	-3060.	6.617	-307132.	0.000	375390.	-3060.	6.617
SM	34293204.	-30453562.	1508.699	-70026152.	0.000	83250232.	-30453562.	1508.699
AV	150409.	-133568.	6.617	-307132.	0.000	365133.	-133568.	6.617
MONTHLY SUMMARY (MAR)								
MN	146535.	-280928.	6.617	-307132.	0.000	355798.	-280928.	6.617
MX	160481.	-14.	6.617	-307132.	0.000	385043.	-14.	6.617
SM	41499576.	-19427706.	1826.321	-84768488.	0.000	100752304.	-19427706.	1826.321
AV	150361.	-70390.	6.617	-307132.	0.000	365045.	-70390.	6.617
MONTHLY SUMMARY (APR)								
MN	142169.	-223390.	6.617	-307132.	0.000	359353.	-223390.	6.617
MX	164461.	-4.	6.617	-307132.	0.000	416350.	-4.	6.617
SM	38068692.	-6212006.	1667.510	-77397320.	0.000	92850672.	-6212006.	1667.510
AV	151066.	-24651.	6.617	-307132.	0.000	368455.	-24651.	6.617
MONTHLY SUMMARY (MAY)								
MN	137912.	0.	6.617	0.	0.000	334862.	0.	6.617
MX	176538.	0.	6.617	0.	18.350	397572.	0.	6.617
SM	38823568.	0.	1667.510	0.	1418.749	93555920.	0.	1667.510
AV	154062.	0.	6.617	0.	5.630	371254.	0.	6.617
MONTHLY SUMMARY (JUN)								
MN	139392.	0.	6.617	0.	0.000	339719.	0.	6.617
MX	180543.	0.	6.617	0.	36.549	408819.	0.	6.617
SM	42252224.	0.	1746.915	0.	4551.683	98785568.	0.	1746.915
AV	160046.	0.	6.617	0.	17.241	374188.	0.	6.617
MONTHLY SUMMARY (JUL)								
MN	141452.	0.	6.617	0.	8.615	342157.	0.	6.617
MX	188065.	0.	6.617	0.	38.304	401096.	0.	6.617
SM	38061492.	0.	1588.105	0.	5623.217	90328304.	0.	1588.105
AV	158590.	0.	6.617	0.	23.430	376368.	0.	6.617

	AC-5	AC-6	AC-6	AC-6	AC-6	AC-6	AC-7	AC-7
	COOLING CAPACITY BTU/HR	TOT HTG COIL PWR BTU/HR	SUPPLY ELECTRIC KW	HEATING CAPACITY BTU/HR	COOLING ELECTRIC KW	COOLING CAPACITY BTU/HR	TOT HTG COIL PWR BTU/HR	SUPPLY ELECTRIC KW
	----(70)	----(5)	----(49)	----(78)	----(47)	----(70)	----(5)	----(49)
MONTHLY SUMMARY (AUG)								
MN	144467.	0.	6.617	0.	0.000	349282.	0.	6.617
MX	173381.	0.	6.617	0.	35.845	404777.	0.	6.617
SM	42896196.	0.	1826.321	0.	6011.198	103456920.	0.	1826.321
AV	155421.	0.	6.617	0.	21.780	374844.	0.	6.617
MONTHLY SUMMARY (SEP)								
MN	143748.	0.	6.617	0.	0.000	347961.	0.	6.617
MX	165946.	0.	6.617	0.	34.120	399263.	0.	6.617
SM	38777644.	0.	1667.510	0.	3324.686	93708184.	0.	1667.510
AV	153880.	0.	6.617	0.	13.193	371858.	0.	6.617
MONTHLY SUMMARY (OCT)								
MN	147324.	-227459.	6.617	-307132.	0.000	354074.	-227459.	6.617
MX	166613.	0.	6.617	0.	15.898	399429.	0.	6.617
SM	36543388.	-11037219.	1588.105	-40541452.	1711.259	88537264.	-11037219.	1588.105
AV	152264.	-45988.	6.617	-168923.	7.130	368905.	-45988.	6.617
MONTHLY SUMMARY (NOV)								
MN	150255.	-257798.	6.617	-307132.	0.000	364832.	-257798.	6.617
MX	184934.	-2.	6.617	-307132.	0.000	452593.	-2.	6.617
SM	36887548.	-15810311.	1588.105	-73711736.	0.000	89808952.	-15810311.	1588.105
AV	153698.	-65876.	6.617	-307132.	0.000	374204.	-65876.	6.617
MONTHLY SUMMARY (DEC)								
MN	150255.	-285376.	6.617	-307132.	0.000	364832.	-285376.	6.617
MX	158303.	-8429.	6.617	-307132.	0.000	379506.	-8429.	6.617
SM	37907100.	-33731212.	1667.510	-77397320.	0.000	92004704.	-33731212.	1667.510
AV	150425.	-133854.	6.617	-307132.	0.000	365098.	-133854.	6.617
YEARLY SUMMARY								
MN	137912.	-302376.	6.617	-307132.	0.000	334862.	-302376.	6.617
MX	188065.	0.	6.617	0.	38.304	452593.	0.	6.617
SM	463874976.	-156154208.	20010.119	-501239776.	22640.791	1118976768.	-156154208.	20010.119
AV	153398.	-51638.	6.617	-165754.	7.487	370032.	-51638.	6.617

MMDDHH	AC-7	AC-7	AC-7	AC-8	AC-8	AC-8	AC-8	AC-8
	HEATING CAPACITY BTU/HR	COOLING ELECTRIC KW	COOLING CAPACITY BTU/HR	TOT HTG COIL PWR BTU/HR	SUPPLY ELECTRIC KW	HEATING CAPACITY BTU/HR	COOLING ELECTRIC KW	COOLING CAPACITY BTU/HR
	---- (78)	---- (47)	---- (70)	---- (5)	---- (49)	---- (78)	---- (47)	---- (70)
MONTHLY SUMMARY (JAN)								
MN	-307132.	0.000	364832.	-403850.	8.901	-410426.	0.000	467995.
MX	-307132.	0.000	364832.	-72315.	8.901	-410426.	0.000	467995.
SM	-77397320.	0.000	91937720.	-59865028.	2243.052	-103427472.	0.000	117934824.
AV	-307132.	0.000	364832.	-237560.	8.901	-410426.	0.000	467995.
MONTHLY SUMMARY (FEB)								
MN	-307132.	0.000	364832.	-404282.	8.901	-410426.	0.000	467995.
MX	-307132.	0.000	375390.	-6965.	8.901	-410426.	0.000	477766.
SM	-70026152.	0.000	83250232.	-45760808.	2029.428	-93577232.	0.000	106747432.
AV	-307132.	0.000	365133.	-200705.	8.901	-410426.	0.000	468191.
MONTHLY SUMMARY (MAR)								
MN	-307132.	0.000	355798.	-372932.	8.901	-410426.	0.000	456407.
MX	-307132.	0.000	385043.	-14.	8.901	-410426.	0.000	491539.
SM	-84768488.	0.000	100752304.	-33980424.	2456.676	-113277712.	0.000	129198784.
AV	-307132.	0.000	365045.	-123117.	8.901	-410427.	0.000	468112.
MONTHLY SUMMARY (APR)								
MN	-307132.	0.000	359353.	-293800.	8.901	-410426.	0.000	460363.
MX	-307132.	0.000	416350.	-6.	8.901	-410426.	0.000	528125.
SM	-77397320.	0.000	92850672.	-13021490.	2243.052	-103427472.	0.000	118772160.
AV	-307132.	0.000	368455.	-51673.	8.901	-410426.	0.000	471318.
MONTHLY SUMMARY (MAY)								
MN	0.	0.000	334862.	0.	8.901	0.	0.000	429550.
MX	0.	18.350	397572.	0.	8.901	0.	21.558	511630.
SM	0.	1418.749	93555920.	0.	2243.052	0.	1497.367	119838584.
AV	0.	5.630	371254.	0.	8.901	0.	5.942	475550.
MONTHLY SUMMARY (JUN)								
MN	0.	0.000	339719.	0.	8.901	0.	0.000	436138.
MX	0.	36.549	408819.	0.	8.901	0.	46.338	519614.
SM	0.	4551.683	98785568.	0.	2349.864	0.	5351.581	126562904.
AV	0.	17.241	374188.	0.	8.901	0.	20.271	479405.
MONTHLY SUMMARY (JUL)								
MN	0.	8.615	342157.	0.	8.901	0.	5.476	436338.
MX	0.	38.304	401096.	0.	8.901	0.	48.894	516437.
SM	0.	5623.217	90328304.	0.	2136.240	0.	6629.475	115841424.
AV	0.	23.430	376368.	0.	8.901	0.	27.623	482673.

	AC-7	AC-7	AC-7	AC-8	AC-8	AC-8	AC-8	AC-8
	HEATING CAPACITY BTU/HR	COOLING ELECTRIC KW	COOLING CAPACITY BTU/HR	TOT HTG COIL PWR BTU/HR	SUPPLY ELECTRIC KW	HEATING CAPACITY BTU/HR	COOLING ELECTRIC KW	COOLING CAPACITY BTU/HR
	----(78)	----(47)	----(70)	----(5)	----(49)	----(78)	----(47)	----(70)
MONTHLY SUMMARY (AUG)								
MN	0.	0.000	349282.	0.	8.901	0.	0.000	446868.
MX	0.	35.845	404777.	0.	8.901	0.	45.299	517060.
SM	0.	6011.198	103456920.	0.	2456.676	0.	7079.895	132705736.
AV	0.	21.780	374844.	0.	8.901	0.	25.652	480818.
MONTHLY SUMMARY (SEP)								
MN	0.	0.000	347961.	0.	8.901	0.	0.000	445659.
MX	0.	34.120	399263.	0.	8.901	0.	42.193	506175.
SM	0.	3324.686	93708184.	0.	2243.052	0.	3719.267	119976632.
AV	0.	13.193	371858.	0.	8.901	0.	14.759	476098.
MONTHLY SUMMARY (OCT)								
MN	-307132.	0.000	354074.	-302092.	8.901	-410426.	0.000	449778.
MX	0.	15.898	399429.	0.	8.901	0.	19.055	507486.
SM	-40541452.	1711.259	88537264.	-17555240.	2136.240	-54176280.	1920.647	113327392.
AV	-168923.	7.130	368905.	-73147.	8.901	-225735.	8.003	472197.
MONTHLY SUMMARY (NOV)								
MN	-307132.	0.000	364832.	-351974.	8.901	-410426.	0.000	467995.
MX	-307132.	0.000	452593.	-3.	8.901	-410426.	0.000	575110.
SM	-73711736.	0.000	89808952.	-26958150.	2136.240	-98502352.	0.000	114951592.
AV	-307132.	0.000	374204.	-112326.	8.901	-410426.	0.000	478965.
MONTHLY SUMMARY (DEC)								
MN	-307132.	0.000	364832.	-384429.	8.901	-410426.	0.000	467995.
MX	-307132.	0.000	379506.	-29957.	8.901	-410426.	0.000	482740.
SM	-77397320.	0.000	92004704.	-52279696.	2243.052	-103427472.	0.000	117989752.
AV	-307132.	0.000	365098.	-207459.	8.901	-410426.	0.000	468213.
YEARLY SUMMARY								
MN	-307132.	0.000	334862.	-404282.	8.901	-410426.	0.000	429550.
MX	0.	38.304	452593.	0.	8.901	0.	48.894	575110.
SM	-501239776.	22640.791	1118976768.	-249420848.	26916.629	-669816000.	26198.232	1433847040.
AV	-165754.	7.487	370032.	-82480.	8.901	-221500.	8.663	474156.

ENTECH ENGINEERING
READING, PA 19603
REPORT- PV-A EQUIPMENT SIZES

EZDOE - ELITE SOFTWARE DEVELOPMENT INC
FT. GEORGE G. MEADE

DOE-2.1D 6/ 7/1996 10:38:32 EDL RUN 1
EMCS FEASIBILITY STUDY
WEATHER FILE- BALTIMORE, MD

EQUIPMENT	NUMBER		NUMBER		NUMBER		NUMBER		NUMBER	
	SIZE	INSTD	SIZE	INSTD	SIZE	INSTD	SIZE	INSTD	SIZE	INSTD
	(MBTU/H)	AVAIL	(MBTU/H)	AVAIL	(MBTU/H)	AVAIL	(MBTU/H)	AVAIL	(MBTU/H)	AVAIL
HW-BOILER	2.400	2	2							

S I T E E N E R G Y													* SOURCE
MONTH	2	3	4	5	6	7	8	9	10	11	12	13	14
	TOTAL HEAT LOAD	TOTAL COOLING LOAD	TOTAL ELECTR LOAD	RCVRED ENERGY	WASTED RCVRABL ENERGY	FUEL INPUT COOLING	ELEC INPUT COOLING	FUEL INPUT HEATING	ELEC INPUT HEATING	FUEL INPUT ELECT	TOTAL FUEL INPUT	TOTAL SITE ENERGY	TOTAL SOURCE ENERGY
JAN	489.3	0.0	311.2 91.1E	0.0	0.0	0.0	0.0 0.0E	695.3	30.2 8.8E	0.0	695.3	1006.5	1629.9
FEB	399.7	0.0	281.3 82.4E	0.0	0.0	0.0	0.0 0.0E	577.9	27.0 7.9E	0.0	577.9	859.2	1422.6
MAR	252.6	0.0	310.9 91.0E	0.0	0.0	0.0	0.0 0.0E	375.7	21.6 6.3E	0.0	375.7	686.6	1309.2
APR	118.8	0.0	278.4 81.5E	0.0	0.0	0.0	0.0 0.0E	185.7	15.0 4.4E	0.0	185.7	464.1	1021.8
MAY	0.0	0.0	346.9 101.6E	0.0	0.0	0.0	0.0 0.0E	0.0	0.0 0.0E	0.0	0.0	346.9	1041.8
JUN	0.0	0.0	389.6 114.1E	0.0	0.0	0.0	0.0 0.0E	0.0	0.0 0.0E	0.0	0.0	389.6	1170.1
JUL	0.0	0.0	393.1 115.1E	0.0	0.0	0.0	0.0 0.0E	0.0	0.0 0.0E	0.0	0.0	393.1	1180.5
AUG	0.0	0.0	439.1 128.6E	0.0	0.0	0.0	0.0 0.0E	0.0	0.0 0.0E	0.0	0.0	439.1	1318.6
SEP	0.0	0.0	372.4 109.1E	0.0	0.0	0.0	0.0 0.0E	0.0	0.0 0.0E	0.0	0.0	372.4	1118.2
OCT	90.3	0.0	343.4 100.6E	0.0	0.0	0.0	0.0 0.0E	140.3	9.8 2.9E	0.0	140.3	483.7	1171.5
NOV	167.6	0.0	274.3 80.3E	0.0	0.0	0.0	0.0 0.0E	256.2	17.5 5.1E	0.0	256.2	530.6	1080.1
DEC	381.6	0.0	305.3 89.4E	0.0	0.0	0.0	0.0 0.0E	561.4	28.3 8.3E	0.0	561.4	866.6	1478.0
*****	1900.0	0.0	4045.9 1184.9E	0.0	0.0	0.0	0.0 0.0E	2792.5	149.4 43.8E	0.0	2792.5	6838.4	14942.3

NOTE-- ALL ENTRIES ARE IN MBTU EXCEPT
 ENTRIES FOLLOWED BY E ARE IN MWH (THOUSANDS OF KWH)

MO	UTILITY-	ELECTRICITY	FUEL-OIL
	TOTAL (MBTU)	311.207	695.315
JAN	PEAK (KBTU)	1061.289	2911.713
	DY/HR	31/17	17/10
	TOTAL (MBTU)	281.282	577.870
FEB	PEAK (KBTU)	1061.289	2828.936
	DY/HR	28/11	14/10
	TOTAL (MBTU)	310.864	375.694
MAR	PEAK (KBTU)	1061.289	2697.229
	DY/HR	31/ 7	7/ 8
	TOTAL (MBTU)	278.402	185.733
APR	PEAK (KBTU)	1061.289	2231.939
	DY/HR	28/ 7	4/ 7
	TOTAL (MBTU)	346.925	0.000
MAY	PEAK (KBTU)	1415.798	0.000
	DY/HR	26/16	31/ 1
	TOTAL (MBTU)	389.637	0.000
JUN	PEAK (KBTU)	1882.865	0.000
	DY/HR	29/16	30/ 1
	TOTAL (MBTU)	393.093	0.000
JUL	PEAK (KBTU)	1930.400	0.000
	DY/HR	25/14	31/ 1
	TOTAL (MBTU)	439.093	0.000
AUG	PEAK (KBTU)	1899.103	0.000
	DY/HR	18/17	31/ 1
	TOTAL (MBTU)	372.363	0.000
SEP	PEAK (KBTU)	1853.026	0.000
	DY/HR	2/14	30/ 1
	TOTAL (MBTU)	343.401	140.297
OCT	PEAK (KBTU)	1440.439	2149.700
	DY/HR	18/16	17/ 7
	TOTAL (MBTU)	274.347	256.230
NOV	PEAK (KBTU)	1061.289	2482.524
	DY/HR	30/10	25/ 7
	TOTAL (MBTU)	305.259	561.354
DEC	PEAK (KBTU)	1061.289	2728.153
	DY/HR	30/ 9	12/ 8
	ONE YEAR	4045.872	2792.493
	USE/PEAK	1930.400	2911.713

ENTECH ENGINEERING
READING, PA 19603
REPORT- PS-D PLANT LOADS SATISFIED

EZDOE - ELITE SOFTWARE DEVELOPMENT INC
FT. GEORGE G. MEADE

DOE-2.1D 6/ 7/1996 10:38:32 PDL RUN 1
EMCS FEASIBILITY STUDY
WEATHER FILE- BALTIMORE, MD

HEATING LOADS	MBTU SUPPLIED	PCT OF TOTAL LOAD
-----	-----	-----
HW-BOILER	1900.1	100.0
	=====	=====
LOAD SATISFIED	1900.1	100.0
TOTAL LOAD ON PLANT	1900.1	

ELECTRICAL LOADS	MBTU SUPPLIED	PCT OF TOTAL LOAD
-----	-----	-----
ELECTRICITY	4045.9	100.0
	=====	=====
LOAD SATISFIED	4045.9	100.0
TOTAL LOAD ON PLANT	4045.9	

ENTECH ENGINEERING
READING, PA 19603
REPORT- PS-D PLANT LOADS SATISFIED

EZDOE - ELITE SOFTWARE DEVELOPMENT INC
FT. GEORGE G. MEADE

DOB-2.1D 6/ 7/1996 10:38:32 PDL RUN 1
EMCS FEASIBILITY STUDY
WEATHER FILE- BALTIMORE, MD
(CONTINUED)

SUMMARY OF LOADS MET

TYPE OF LOAD	TOTAL LOAD (MBTU)	LOAD SATISFIED (MBTU)	TOTAL OVERLOAD (MBTU)	PEAK OVERLOAD (MBTU)	HOURS OVERLOADED
HEATING LOADS	1900.1	1900.1	0.000	0.000	0
ELECTRICAL LOADS	4045.9	4045.9	0.000	0.000	0

EQUIPMENT	AVG	MAX	MON	-----		-----		-----		-----	
	OPER RATIO	LOAD (MBTU)	DAY HR	SIZE (MBTU)	OPER HRS	SIZE (MBTU)	OPER HRS	SIZE (MBTU)	OPER HRS	SIZE (MBTU)	OPER HRS
HW-BOILER	0.167	2.316	1 17 10	2.400	4728						

E Q U I P M E N T T O T A L S

HW-BOILER		137.0		
	NOMINAL SIZE (MBTU)		2.400	
	NUMBER INSTALLED		2	
	FIRST COST (K\$)	127.5	127.5	
	ANNUAL COST (K\$)	4.1	4.1	
	CYCLICAL COST (K\$)	5.3	5.3	
	-----TOTAL----(K\$)		137.0	
<hr/>				
EQUIPMENT TOTAL		137.0		

ENERGY TYPE	ELECTRICITY	FUEL-OIL
IN SITE MBTU -		
CATEGORY OF USE		
SPACE HEAT	109.10	2792.55
SPACE COOL	554.86	0.00
HVAC AUX	812.70	0.00
DOM HOT WTR	0.00	0.00
AUX SOLAR	0.00	0.00
LIGHTS	1701.35	0.00
VERT TRANS	0.00	0.00
MISC EQUIP	867.89	0.00
TOTAL	4045.90	2792.55

TOTAL SITE ENERGY 6838.36 MBTU 76.4 KBTU/SQFT-YR GROSS-AREA 76.4 KBTU/SQFT-YR NET-AREA
 TOTAL SOURCE ENERGY 14942.26 MBTU 166.9 KBTU/SQFT-YR GROSS-AREA 166.9 KBTU/SQFT-YR NET-AREA

PERCENT OF HOURS ANY SYSTEM ZONE OUTSIDE OF THROTTLING RANGE = 36.9
 PERCENT OF HOURS ANY PLANT LOAD NOT SATISFIED = 0.0

NOTE ELECTRICITY AND/OR FUEL USED TO GENERATE ELECTRICITY IS APPORTIONED BASED
 ON THE YEARLY DEMAND. ALL OTHER ENERGY TYPES ARE APPORTIONED HOURLY.

MMDDHH	HW-BOILE R LOAD BTU/HR	HW-BOILE R ELECTRIC USE BTU/HR	HW-BOILE R FUEL USE BTU/HR
	----(1)	----(3)	----(4)
MONTHLY SUMMARY (JAN)			
MN	15328.	1349.	25048.
MX	2315999.	52800.	2911713.
SM	489348480.	23868870.	695315072.
AV	657726.	32082.	934563.
MONTHLY SUMMARY (FEB)			
MN	15328.	1349.	25048.
MX	2237740.	52800.	2828936.
SM	399738336.	21231924.	577869504.
AV	594849.	31595.	859925.
MONTHLY SUMMARY (MAR)			
MN	15328.	1349.	25048.
MX	2114196.	52800.	2697229.
SM	252614544.	15249963.	375691776.
AV	339536.	20497.	504962.
MONTHLY SUMMARY (APR)			
MN	15328.	1349.	25048.
MX	1686870.	52800.	2231939.
SM	118764120.	8857763.	185731472.
AV	164950.	12302.	257960.
MONTHLY SUMMARY (OCT)			
MN	15328.	1349.	25048.
MX	1612753.	52800.	2149700.
SM	90269168.	6557418.	140296768.
AV	235076.	17077.	365356.
MONTHLY SUMMARY (NOV)			
MN	15328.	1349.	25048.
MX	1915285.	52800.	2482524.
SM	167634432.	11387166.	256229232.
AV	232826.	15816.	355874.
MONTHLY SUMMARY (DEC)			
MN	15328.	1349.	25048.
MX	2143098.	52800.	2728153.
SM	381636896.	21949216.	561353088.
AV	512953.	29502.	754507.

ENTECH ENGINEERING
READING, PA 19603
PH-1 = HOURLY-REPORT

EZDOE - ELITE SOFTWARE DEVELOPMENT INC
FT. GEORGE G. MEADE

DOE-2.1D 6/ 7/1996 10:38:32 PDL RUN 1
EMCS FEASIBILITY STUDY

PAGE 2- 1

HW-BOILE R LOAD BTU/HR	HW-BOILE R ELECTRIC USE BTU/HR	HW-BOILE R FUEL USE BTU/HR
----(1)	----(3)	----(4)

YEARLY SUMMARY

MN	15328.	1349.	25048.
MX	2315999.	52800.	2911713.
SM	1900006016.	109102320.	2792486912.
AV	401863.	23076.	590628.

BLDG. 4553
W/SETBACK & VENT
FILE: FTM4553N

MMDDHH	AC-1	AC-1	AC-1	AC-1	AC-1	AC-2	AC-2	AC-2
	TOT HTG COIL PWR BTU/HR	SUPPLY ELECTRIC KW	HEATING CAPACITY BTU/HR	COOLING ELECTRIC KW	COOLING CAPACITY BTU/HR	TOT HTG COIL PWR BTU/HR	SUPPLY ELECTRIC KW	HEATING CAPACITY BTU/HR
	----(5)	----(49)	----(78)	----(47)	----(70)	----(5)	----(49)	----(78)
MONTHLY SUMMARY (JAN)								
MN	-133383.	2.870	-132355.	0.000	150178.	-314003.	6.928	-319433.
MX	-27490.	2.870	-132355.	0.000	150178.	-20727.	6.928	-319433.
SM	-20315290.	723.341	-33353338.	0.000	37844976.	-37352688.	1745.755	-80497016.
AV	-80616.	2.870	-132355.	0.000	150178.	-148225.	6.928	-319433.
MONTHLY SUMMARY (FEB)								
MN	-130088.	2.870	-132355.	0.000	150178.	-300057.	6.928	-319433.
MX	-32979.	2.870	-132355.	0.000	155344.	-425.	6.928	-319433.
SM	-20356320.	654.451	-30176830.	0.000	34275736.	-28351482.	1579.493	-72830632.
AV	-89282.	2.870	-132355.	0.000	150332.	-124349.	6.928	-319433.
MONTHLY SUMMARY (MAR)								
MN	-130233.	2.870	-132355.	0.000	146460.	-268482.	6.928	-319433.
MX	-30234.	2.870	-132355.	0.000	160398.	-12.	6.928	-319433.
SM	-22798926.	792.231	-36529848.	0.000	41478208.	-17001712.	1912.018	-88163400.
AV	-82605.	2.870	-132355.	0.000	150283.	-61600.	6.928	-319433.
MONTHLY SUMMARY (APR)								
MN	-127152.	2.870	-132355.	0.000	142096.	-213415.	6.928	-319433.
MX	-16145.	2.870	-132355.	0.000	164360.	-3.	6.928	-319433.
SM	-17256134.	723.341	-33353338.	0.000	38048556.	-5168638.	1745.755	-80497016.
AV	-68477.	2.870	-132355.	0.000	150986.	-20510.	6.928	-319433.
MONTHLY SUMMARY (MAY)								
MN	0.	2.870	0.	0.000	137842.	0.	6.928	0.
MX	0.	2.870	0.	0.000	176352.	0.	6.928	0.
SM	0.	723.341	0.	0.000	38819788.	0.	1745.755	0.
AV	0.	2.870	0.	0.000	154047.	0.	6.928	0.
MONTHLY SUMMARY (JUN)								
MN	0.	2.870	0.	0.000	138947.	0.	6.928	0.
MX	0.	2.870	0.	7.532	182313.	0.	6.928	0.
SM	0.	757.786	0.	365.950	42278608.	0.	1828.887	0.
AV	0.	2.870	0.	1.386	160146.	0.	6.928	0.
MONTHLY SUMMARY (JUL)								
MN	0.	2.870	0.	0.000	141380.	0.	6.928	0.
MX	0.	2.870	0.	10.914	192979.	0.	6.928	0.
SM	0.	688.896	0.	1295.718	38230200.	0.	1662.624	0.
AV	0.	2.870	0.	5.399	159293.	0.	6.928	0.

	AC-1	AC-1	AC-1	AC-1	AC-1	AC-2	AC-2	AC-2
	TOT HTG COIL PWR BTU/HR	SUPPLY ELECTRIC KW	HEATING CAPACITY BTU/HR	COOLING ELECTRIC KW	COOLING CAPACITY BTU/HR	TOT HTG COIL PWR BTU/HR	SUPPLY ELECTRIC KW	HEATING CAPACITY BTU/HR
	---- (5)	---- (49)	---- (78)	---- (47)	---- (70)	---- (5)	---- (49)	---- (78)
MONTHLY SUMMARY (AUG)								
MN	0.	2.870	0.	0.000	144354.	0.	6.928	0.
MX	0.	2.870	0.	12.826	176344.	0.	6.928	0.
SM	0.	792.231	0.	2028.248	42875024.	0.	1912.018	0.
AV	0.	2.870	0.	7.349	155344.	0.	6.928	0.
MONTHLY SUMMARY (SEP)								
MN	0.	2.870	0.	0.000	143658.	0.	6.928	0.
MX	0.	2.870	0.	12.083	167296.	0.	6.928	0.
SM	0.	723.341	0.	1344.824	38759512.	0.	1745.755	0.
AV	0.	2.870	0.	5.337	153808.	0.	6.928	0.
MONTHLY SUMMARY (OCT)								
MN	-60006.	2.870	-132355.	0.000	147215.	-213709.	6.928	-319433.
MX	0.	2.870	0.	8.243	166569.	0.	6.928	0.
SM	-2076782.	688.896	-17470798.	939.383	36509736.	-10143300.	1662.624	-42165096.
AV	-8653.	2.870	-72795.	3.914	152124.	-42264.	6.928	-175688.
MONTHLY SUMMARY (NOV)								
MN	-121027.	2.870	-132355.	0.000	150178.	-271545.	6.928	-319433.
MX	-12.	2.870	-132355.	0.000	184821.	-1.	6.928	-319433.
SM	-3265774.	688.896	-31765084.	0.000	36867512.	-13960373.	1662.624	-76663824.
AV	-13607.	2.870	-132355.	0.000	153615.	-58168.	6.928	-319433.
MONTHLY SUMMARY (DEC)								
MN	-129334.	2.870	-132355.	0.000	150178.	-286230.	6.928	-319433.
MX	-1926.	2.870	-132355.	0.000	158209.	-6515.	6.928	-319433.
SM	-12091773.	723.341	-33353338.	0.000	37887576.	-31427462.	1745.755	-80497016.
AV	-47983.	2.870	-132355.	0.000	150348.	-124712.	6.928	-319433.
YEARLY SUMMARY								
MN	-133383.	2.870	-132355.	0.000	137842.	-314003.	6.928	-319433.
MX	0.	2.870	0.	12.826	192979.	0.	6.928	0.
SM	-98161008.	8680.091	-216002576.	5974.123	463875424.	-143405664.	20949.066	-521313984.
AV	-32461.	2.870	-71429.	1.976	153398.	-47423.	6.928	-172392.

MMDDHH	AC-2	AC-2	AC-3	AC-3	AC-3	AC-3	AC-3	AC-4
	COOLING ELECTRIC KW	COOLING CAPACITY BTU/HR	TOT HTG COIL PWR BTU/HR	SUPPLY ELECTRIC KW	HEATING CAPACITY BTU/HR	COOLING ELECTRIC KW	COOLING CAPACITY BTU/HR	TOT HTG COIL PWR BTU/HR
	----(47)	----(70)	----(5)	----(49)	----(78)	----(47)	----(70)	----(5)
MONTHLY SUMMARY (JAN)								
MN	0.000	375976.	-313774.	6.877	-319214.	0.000	376161.	-403778.
MX	0.000	375976.	-20577.	6.877	-319214.	0.000	376161.	-57419.
SM	0.000	94746072.	-37298124.	1733.105	-80441872.	0.000	94792648.	-57199952.
AV	0.000	375976.	-148008.	6.877	-319214.	0.000	376161.	-226984.
MONTHLY SUMMARY (FEB)								
MN	0.000	375976.	-299831.	6.877	-319214.	0.000	376161.	-397235.
MX	0.000	387320.	-388.	6.877	-319214.	0.000	387560.	-3153.
SM	0.000	85793536.	-28303898.	1568.047	-72780736.	0.000	85836304.	-43329200.
AV	0.000	376287.	-124140.	6.877	-319214.	0.000	376475.	-190040.
MONTHLY SUMMARY (MAR)								
MN	0.000	366666.	-268247.	6.877	-319214.	0.000	366847.	-358666.
MX	0.000	397339.	-12.	6.877	-319214.	0.000	397583.	-13.
SM	0.000	103841176.	-16955568.	1898.163	-88103008.	0.000	103893064.	-30677500.
AV	0.000	376236.	-61433.	6.877	-319214.	0.000	376424.	-111150.
MONTHLY SUMMARY (APR)								
MN	0.000	372230.	-213127.	6.877	-319214.	0.000	372413.	-282411.
MX	0.000	431728.	-3.	6.877	-319214.	0.000	432021.	-5.
SM	0.000	95813408.	-5148250.	1733.105	-80441872.	0.000	95865048.	-11294401.
AV	0.000	380212.	-20430.	6.877	-319214.	0.000	380417.	-44819.
MONTHLY SUMMARY (MAY)								
MN	0.000	345091.	0.	6.877	0.	0.000	345260.	0.
MX	20.186	409541.	0.	6.877	0.	20.208	409786.	0.
SM	1765.437	96336904.	0.	1733.105	0.	1777.484	96383384.	0.
AV	7.006	382289.	0.	6.877	0.	7.054	382474.	0.
MONTHLY SUMMARY (JUN)								
MN	0.000	350275.	0.	6.877	0.	0.000	350477.	0.
MX	38.193	420920.	0.	6.877	0.	38.215	421169.	0.
SM	4912.630	101709584.	0.	1815.634	0.	4935.029	101754760.	0.
AV	18.608	385264.	0.	6.877	0.	18.693	385435.	0.
MONTHLY SUMMARY (JUL)								
MN	8.806	352604.	0.	6.877	0.	8.820	352817.	0.
MX	39.545	414140.	0.	6.877	0.	39.564	414377.	0.
SM	6018.731	93000712.	0.	1650.576	0.	6023.633	93053864.	0.
AV	25.078	387503.	0.	6.877	0.	25.098	387724.	0.

	AC-2	AC-2	AC-3	AC-3	AC-3	AC-3	AC-3	AC-4
	COOLING ELECTRIC KW	COOLING CAPACITY BTU/HR	TOT HTG COIL PWR BTU/HR	SUPPLY ELECTRIC KW	HEATING CAPACITY BTU/HR	COOLING ELECTRIC KW	COOLING CAPACITY BTU/HR	TOT HTG COIL PWR BTU/HR
	----(47)	----(70)	----(5)	----(49)	----(78)	----(47)	----(70)	----(5)
MONTHLY SUMMARY (AUG)								
MN	0.000	359724.	0.	6.877	0.	0.000	359932.	0.
MX	37.540	411467.	0.	6.877	0.	37.562	411699.	0.
SM	6497.070	106471152.	0.	1898.163	0.	6502.662	106532056.	0.
AV	23.540	385765.	0.	6.877	0.	23.560	385986.	0.
MONTHLY SUMMARY (SEP)								
MN	0.000	358749.	0.	6.877	0.	0.000	358953.	0.
MX	35.846	410902.	0.	6.877	0.	35.868	411145.	0.
SM	3675.909	96471024.	0.	1733.105	0.	3684.761	96524832.	0.
AV	14.587	382822.	0.	6.877	0.	14.622	383035.	0.
MONTHLY SUMMARY (OCT)								
MN	0.000	365178.	-213519.	6.877	-319214.	0.000	365401.	-298410.
MX	18.299	411287.	0.	6.877	0.	18.295	411532.	0.
SM	2003.509	91182768.	-10131154.	1650.576	-42136220.	2011.738	91225784.	-16371250.
AV	8.348	379928.	-42213.	6.877	-175568.	8.382	380107.	-68214.
MONTHLY SUMMARY (NOV)								
MN	0.000	375976.	-271314.	6.877	-319214.	0.000	376161.	-347884.
MX	0.000	467955.	-1.	6.877	-319214.	0.000	468252.	-2.
SM	0.000	92624656.	-13925379.	1650.576	-76611304.	0.000	92673456.	-24824984.
AV	0.000	385936.	-58022.	6.877	-319214.	0.000	386139.	-103437.
MONTHLY SUMMARY (DEC)								
MN	0.000	375976.	-286001.	6.877	-319214.	0.000	376161.	-369771.
MX	0.000	391727.	-6445.	6.877	-319214.	0.000	391969.	-23166.
SM	0.000	94818472.	-31374242.	1733.105	-80441872.	0.000	94865552.	-49284776.
AV	0.000	376264.	-124501.	6.877	-319214.	0.000	376451.	-195575.
YEARLY SUMMARY								
MN	0.000	345091.	-313774.	6.877	-319214.	0.000	345260.	-403778.
MX	39.545	467955.	0.	6.877	0.	39.564	468252.	0.
SM	24873.285	1152809472.	-143136608.	20797.262	-520956864.	24935.309	1153400832.	-232982048.
AV	8.225	381220.	-47334.	6.877	-172274.	8.246	381416.	-77044.

MMDDHH	AC-4	AC-4	AC-4	AC-4	AC-5	AC-5	AC-5	AC-5
	SUPPLY ELECTRIC KW	HEATING CAPACITY BTU/HR	COOLING ELECTRIC KW	COOLING CAPACITY BTU/HR	TOT HTG COIL PWR BTU/HR	SUPPLY ELECTRIC KW	HEATING CAPACITY BTU/HR	COOLING ELECTRIC KW
	----(49)	----(78)	----(47)	----(70)	----(5)	----(49)	----(78)	----(47)
MONTHLY SUMMARY (JAN)								
MN	8.843	-410463.	0.000	468582.	-133287.	2.850	-132264.	0.000
MX	8.843	-410463.	0.000	468582.	-27411.	2.850	-132264.	0.000
SM	2228.525	-103436760.	0.000	118082792.	-20292364.	718.099	-33330526.	0.000
AV	8.843	-410463.	0.000	468583.	-80525.	2.850	-132264.	0.000
MONTHLY SUMMARY (FEB)								
MN	8.843	-410463.	0.000	468582.	-129993.	2.850	-132264.	0.000
MX	8.843	-410463.	0.000	479111.	-32899.	2.850	-132264.	0.000
SM	2016.284	-93585640.	0.000	106885032.	-20335296.	649.709	-30156190.	0.000
AV	8.843	-410463.	0.000	468794.	-89190.	2.850	-132264.	0.000
MONTHLY SUMMARY (MAR)								
MN	8.843	-410463.	0.000	456979.	-130138.	2.850	-132264.	0.000
MX	8.843	-410463.	0.000	492366.	-30155.	2.850	-132264.	0.000
SM	2440.765	-113287880.	0.000	129366472.	-22773640.	786.490	-36504860.	0.000
AV	8.843	-410463.	0.000	468719.	-82513.	2.850	-132264.	0.000
MONTHLY SUMMARY (APR)								
MN	8.843	-410463.	0.000	461592.	-127055.	2.850	-132264.	0.000
MX	8.843	-410463.	0.000	531615.	-16069.	2.850	-132264.	0.000
SM	2228.525	-103436760.	0.000	119018256.	-17233538.	718.099	-33330526.	0.000
AV	8.843	-410463.	0.000	472295.	-68387.	2.850	-132264.	0.000
MONTHLY SUMMARY (MAY)								
MN	8.843	0.	0.000	430089.	0.	2.850	0.	0.000
MX	8.843	0.	23.197	510153.	0.	2.850	0.	0.000
SM	2228.525	0.	1838.706	119949368.	0.	718.099	0.	0.000
AV	8.843	0.	7.296	475990.	0.	2.850	0.	0.000
MONTHLY SUMMARY (JUN)								
MN	8.843	0.	0.000	436685.	0.	2.850	0.	0.000
MX	8.843	0.	46.958	520498.	0.	2.850	0.	7.552
SM	2334.645	0.	5704.584	126570064.	0.	752.294	0.	369.493
AV	8.843	0.	21.608	479432.	0.	2.850	0.	1.400
MONTHLY SUMMARY (JUL)								
MN	8.843	0.	8.072	437104.	0.	2.850	0.	0.000
MX	8.843	0.	49.159	518362.	0.	2.850	0.	10.929
SM	2122.405	0.	6961.360	115866584.	0.	683.904	0.	1300.240
AV	8.843	0.	29.006	482777.	0.	2.850	0.	5.418

	AC-4	AC-4	AC-4	AC-4	AC-5	AC-5	AC-5	AC-5
	SUPPLY ELECTRIC KW	HEATING CAPACITY BTU/HR	COOLING ELECTRIC KW	COOLING CAPACITY BTU/HR	TOT HTG COIL PWR BTU/HR	SUPPLY ELECTRIC KW	HEATING CAPACITY BTU/HR	COOLING ELECTRIC KW
	----(49)	----(78)	----(47)	----(70)	----(5)	----(49)	----(78)	----(47)
MONTHLY SUMMARY (AUG)								
MN	8.843	0.	0.000	447082.	0.	2.850	0.	0.000
MX	8.843	0.	46.128	515502.	0.	2.850	0.	12.794
SM	2440.765	0.	7494.784	132662488.	0.	786.490	0.	2030.832
AV	8.843	0.	27.155	480661.	0.	2.850	0.	7.358
MONTHLY SUMMARY (SEP)								
MN	8.843	0.	0.000	446199.	0.	2.850	0.	0.000
MX	8.843	0.	43.475	506652.	0.	2.850	0.	12.094
SM	2228.525	0.	4126.221	120027112.	0.	718.099	0.	1347.346
AV	8.843	0.	16.374	476298.	0.	2.850	0.	5.347
MONTHLY SUMMARY (OCT)								
MN	8.843	-410463.	0.000	451476.	-59948.	2.850	-132264.	0.000
MX	8.843	0.	20.617	508432.	0.	2.850	0.	8.252
SM	2122.405	-54181160.	2191.366	113475032.	-2073701.	683.904	-17458846.	940.721
AV	8.843	-225755.	9.131	472813.	-8640.	2.850	-72745.	3.920
MONTHLY SUMMARY (NOV)								
MN	8.843	-410463.	0.000	468582.	-120932.	2.850	-132264.	0.000
MX	8.843	-410463.	0.000	577829.	-12.	2.850	-132264.	0.000
SM	2122.405	-98511200.	0.000	115172944.	-3255705.	683.904	-31743358.	0.000
AV	8.843	-410463.	0.000	479887.	-13565.	2.850	-132264.	0.000
MONTHLY SUMMARY (DEC)								
MN	8.843	-410463.	0.000	468582.	-129240.	2.850	-132264.	0.000
MX	8.843	-410463.	0.000	483828.	-1827.	2.850	-132264.	0.000
SM	2228.525	-103436760.	0.000	118140960.	-12069547.	718.099	-33330526.	0.000
AV	8.843	-410463.	0.000	468813.	-47895.	2.850	-132264.	0.000
YEARLY SUMMARY								
MN	8.843	-410463.	0.000	430089.	-133287.	2.850	-132264.	0.000
MX	8.843	0.	49.159	577829.	0.	2.850	0.	12.794
SM	26742.297	-669876160.	28317.020	1435217152.	-98033792.	8617.189	-215854832.	5988.631
AV	8.843	-221520.	9.364	474609.	-32419.	2.850	-71381.	1.980

MMDDHH	AC-5	AC-6	AC-6	AC-6	AC-6	AC-6	AC-7	AC-7
	COOLING CAPACITY BTU/HR	TOT HTG COIL PWR BTU/HR	SUPPLY ELECTRIC KW	HEATING CAPACITY BTU/HR	COOLING ELECTRIC KW	COOLING CAPACITY BTU/HR	TOT HTG COIL PWR BTU/HR	SUPPLY ELECTRIC KW
	---- (70)	---- (5)	---- (49)	---- (78)	---- (47)	---- (70)	---- (5)	---- (49)
MONTHLY SUMMARY (JAN)								
MN	150255.	-302281.	6.617	-307132.	0.000	364832.	-302281.	6.617
MX	150255.	-26147.	6.617	-307132.	0.000	364832.	-26147.	6.617
SM	37864352.	-39463456.	1667.510	-77397320.	0.000	91937720.	-39463456.	1667.510
AV	150255.	-156601.	6.617	-307132.	0.000	364832.	-156601.	6.617
MONTHLY SUMMARY (FEB)								
MN	150255.	-299187.	6.617	-307132.	0.000	364832.	-299187.	6.617
MX	155440.	-2937.	6.617	-307132.	0.000	375405.	-2937.	6.617
SM	34293496.	-30384810.	1508.699	-70026152.	0.000	83250344.	-30384810.	1508.699
AV	150410.	-133267.	6.617	-307132.	0.000	365133.	-133267.	6.617
MONTHLY SUMMARY (MAR)								
MN	146535.	-276673.	6.617	-307132.	0.000	355798.	-276673.	6.617
MX	160497.	-14.	6.617	-307132.	0.000	385046.	-14.	6.617
SM	41499644.	-19366884.	1826.321	-84768488.	0.000	100752360.	-19366884.	1826.321
AV	150361.	-70170.	6.617	-307132.	0.000	365045.	-70170.	6.617
MONTHLY SUMMARY (APR)								
MN	142169.	-223293.	6.617	-307132.	0.000	359354.	-223293.	6.617
MX	164461.	-4.	6.617	-307132.	0.000	416350.	-4.	6.617
SM	38068704.	-6190365.	1667.510	-77397320.	0.000	92850864.	-6190365.	1667.510
AV	151066.	-24565.	6.617	-307132.	0.000	368456.	-24565.	6.617
MONTHLY SUMMARY (MAY)								
MN	137912.	0.	6.617	0.	0.000	334862.	0.	6.617
MX	176476.	0.	6.617	0.	18.354	397740.	0.	6.617
SM	38843376.	0.	1667.510	0.	1578.958	93552440.	0.	1667.510
AV	154140.	0.	6.617	0.	6.266	371240.	0.	6.617
MONTHLY SUMMARY (JUN)								
MN	139041.	0.	6.617	0.	0.000	339719.	0.	6.617
MX	182433.	0.	6.617	0.	36.549	408819.	0.	6.617
SM	42300768.	0.	1746.915	0.	4565.173	98778400.	0.	1746.915
AV	160230.	0.	6.617	0.	17.292	374161.	0.	6.617
MONTHLY SUMMARY (JUL)								
MN	141452.	0.	6.617	0.	8.615	342157.	0.	6.617
MX	193105.	0.	6.617	0.	38.304	401058.	0.	6.617
SM	38247576.	0.	1588.105	0.	5623.079	90328832.	0.	1588.105
AV	159365.	0.	6.617	0.	23.429	376370.	0.	6.617

	AC-5	AC-6	AC-6	AC-6	AC-6	AC-6	AC-7	AC-7
	COOLING CAPACITY BTU/HR	TOT HTG COIL PWR BTU/HR	SUPPLY ELECTRIC KW	HEATING CAPACITY BTU/HR	COOLING ELECTRIC KW	COOLING CAPACITY BTU/HR	TOT HTG COIL PWR BTU/HR	SUPPLY ELECTRIC KW
	---- (70)	---- (5)	---- (49)	---- (78)	---- (47)	---- (70)	---- (5)	---- (49)
MONTHLY SUMMARY (AUG)								
MN	144449.	0.	6.617	0.	0.000	349282.	0.	6.617
MX	176463.	0.	6.617	0.	35.845	404784.	0.	6.617
SM	42899576.	0.	1826.321	0.	6011.826	103458824.	0.	1826.321
AV	155433.	0.	6.617	0.	21.782	374851.	0.	6.617
MONTHLY SUMMARY (SEP)								
MN	143743.	0.	6.617	0.	0.000	347961.	0.	6.617
MX	167316.	0.	6.617	0.	34.120	399263.	0.	6.617
SM	38781600.	0.	1667.510	0.	3368.136	93710832.	0.	1667.510
AV	153895.	0.	6.617	0.	13.366	371868.	0.	6.617
MONTHLY SUMMARY (OCT)								
MN	147303.	-220787.	6.617	-307132.	0.000	354618.	-220787.	6.617
MX	166672.	0.	6.617	0.	16.436	399450.	0.	6.617
SM	36530292.	-10800273.	1588.105	-40541452.	1824.059	88537936.	-10800273.	1588.105
AV	152210.	-45001.	6.617	-168923.	7.600	368908.	-45001.	6.617
MONTHLY SUMMARY (NOV)								
MN	150255.	-257330.	6.617	-307132.	0.000	364832.	-257330.	6.617
MX	184934.	-2.	6.617	-307132.	0.000	452593.	-2.	6.617
SM	36887548.	-15761565.	1588.105	-73711736.	0.000	89808984.	-15761565.	1588.105
AV	153698.	-65673.	6.617	-307132.	0.000	374204.	-65673.	6.617
MONTHLY SUMMARY (DEC)								
MN	150255.	-281187.	6.617	-307132.	0.000	364832.	-281187.	6.617
MX	158307.	-8324.	6.617	-307132.	0.000	379526.	-8324.	6.617
SM	37907144.	-33574860.	1667.510	-77397320.	0.000	92004832.	-33574860.	1667.510
AV	150425.	-133234.	6.617	-307132.	0.000	365099.	-133234.	6.617
YEARLY SUMMARY								
MN	137912.	-302281.	6.617	-307132.	0.000	334862.	-302281.	6.617
MX	193105.	0.	6.617	0.	38.304	452593.	0.	6.617
SM	464124096.	-155542224.	20010.119	-501239776.	22971.232	1118972416.	-155542224.	20010.119
AV	153480.	-51436.	6.617	-165754.	7.596	370031.	-51436.	6.617

MMDDHH	AC-7	AC-7	AC-7	AC-8	AC-8	AC-8	AC-8	AC-8
	HEATING CAPACITY BTU/HR	COOLING ELECTRIC KW	COOLING CAPACITY BTU/HR	TOT HTG COIL PWR BTU/HR	SUPPLY ELECTRIC KW	HEATING CAPACITY BTU/HR	COOLING ELECTRIC KW	COOLING CAPACITY BTU/HR
	---- (78)	---- (47)	---- (70)	---- (5)	---- (49)	---- (78)	---- (47)	---- (70)
MONTHLY SUMMARY (JAN)								
MN	-307132.	0.000	364832.	-408594.	8.901	-410426.	0.000	467995.
MX	-307132.	0.000	364832.	-72026.	8.901	-410426.	0.000	467995.
SM	-77397320.	0.000	91937720.	-59839600.	2243.052	-103427472.	0.000	117934824.
AV	-307132.	0.000	364832.	-237459.	8.901	-410426.	0.000	467995.
MONTHLY SUMMARY (FEB)								
MN	-307132.	0.000	364832.	-404020.	8.901	-410426.	0.000	467995.
MX	-307132.	0.000	375405.	-6728.	8.901	-410426.	0.000	477775.
SM	-70026152.	0.000	83250344.	-45834108.	2029.428	-93577232.	0.000	106747504.
AV	-307132.	0.000	365133.	-201027.	8.901	-410426.	0.000	468191.
MONTHLY SUMMARY (MAR)								
MN	-307132.	0.000	355798.	-368965.	8.901	-410426.	0.000	456407.
MX	-307132.	0.000	385046.	-14.	8.901	-410426.	0.000	491541.
SM	-84768488.	0.000	100752360.	-33891224.	2456.676	-113277712.	0.000	129198800.
AV	-307132.	0.000	365045.	-122794.	8.901	-410427.	0.000	468112.
MONTHLY SUMMARY (APR)								
MN	-307132.	0.000	359354.	-293797.	8.901	-410426.	0.000	460363.
MX	-307132.	0.000	416350.	-6.	8.901	-410426.	0.000	528125.
SM	-77397320.	0.000	92850864.	-12995934.	2243.052	-103427472.	0.000	118772200.
AV	-307132.	0.000	368456.	-51571.	8.901	-410426.	0.000	471318.
MONTHLY SUMMARY (MAY)								
MN	0.	0.000	334862.	0.	8.901	0.	0.000	429550.
MX	0.	18.354	397740.	0.	8.901	0.	21.581	511154.
SM	0.	1578.958	93552440.	0.	2243.052	0.	1660.563	119854632.
AV	0.	6.266	371240.	0.	8.901	0.	6.590	475614.
MONTHLY SUMMARY (JUN)								
MN	0.	0.000	339719.	0.	8.901	0.	0.000	436138.
MX	0.	36.549	408819.	0.	8.901	0.	46.338	519614.
SM	0.	4565.173	98778400.	0.	2349.864	0.	5392.529	126545136.
AV	0.	17.292	374161.	0.	8.901	0.	20.426	479338.
MONTHLY SUMMARY (JUL)								
MN	0.	8.615	342157.	0.	8.901	0.	5.476	436338.
MX	0.	38.304	401058.	0.	8.901	0.	48.894	516437.
SM	0.	5623.079	90328832.	0.	2136.240	0.	6629.373	115842432.
AV	0.	23.429	376370.	0.	8.901	0.	27.622	482677.

	AC-7	AC-7	AC-7	AC-8	AC-8	AC-8	AC-8	AC-8
	HEATING CAPACITY BTU/HR	COOLING ELECTRIC KW	COOLING CAPACITY BTU/HR	TOT HTG COIL PWR BTU/HR	SUPPLY ELECTRIC KW	HEATING CAPACITY BTU/HR	COOLING ELECTRIC KW	COOLING CAPACITY BTU/HR
	----(78)	----(47)	----(70)	----(5)	----(49)	----(78)	----(47)	----(70)
MONTHLY SUMMARY (AUG)								
MN	0.	0.000	349282.	0.	8.901	0.	0.000	446868.
MX	0.	35.845	404784.	0.	8.901	0.	45.299	517061.
SM	0.	6011.826	103458824.	0.	2456.676	0.	7097.206	132708240.
AV	0.	21.782	374851.	0.	8.901	0.	25.715	480827.
MONTHLY SUMMARY (SEP)								
MN	0.	0.000	347961.	0.	8.901	0.	0.000	445659.
MX	0.	34.120	399263.	0.	8.901	0.	42.193	506175.
SM	0.	3368.136	93710832.	0.	2243.052	0.	3839.143	119982496.
AV	0.	13.366	371868.	0.	8.901	0.	15.235	476121.
MONTHLY SUMMARY (OCT)								
MN	-307132.	0.000	354618.	-304175.	8.901	-410426.	0.000	450573.
MX	0.	16.436	399450.	0.	8.901	0.	19.099	507533.
SM	-40541452.	1824.059	88537936.	-17476952.	2136.240	-54176280.	2046.416	113352304.
AV	-168923.	7.600	368908.	-72821.	8.901	-225735.	8.527	472301.
MONTHLY SUMMARY (NOV)								
MN	-307132.	0.000	364832.	-354438.	8.901	-410426.	0.000	467995.
MX	-307132.	0.000	452593.	-3.	8.901	-410426.	0.000	575110.
SM	-73711736.	0.000	89808984.	-26937622.	2136.240	-98502352.	0.000	114951592.
AV	-307132.	0.000	374204.	-112240.	8.901	-410426.	0.000	478965.
MONTHLY SUMMARY (DEC)								
MN	-307132.	0.000	364832.	-381851.	8.901	-410426.	0.000	467995.
MX	-307132.	0.000	379526.	-29440.	8.901	-410426.	0.000	482747.
SM	-77397320.	0.000	92004832.	-52066728.	2243.052	-103427472.	0.000	117989848.
AV	-307132.	0.000	365099.	-206614.	8.901	-410426.	0.000	468214.
YEARLY SUMMARY								
MN	-307132.	0.000	334862.	-408594.	8.901	-410426.	0.000	429550.
MX	0.	38.304	452593.	0.	8.901	0.	48.894	575110.
SM	-501239776.	22971.232	1118972416.	-249042176.	26916.629	-669816000.	26665.230	1433880064.
AV	-165754.	7.596	370031.	-82355.	8.901	-221500.	8.818	474167.

ENTECH ENGINEERING
READING, PA 19603
REPORT- PV-A EQUIPMENT SIZES

EZDOE - ELITE SOFTWARE DEVELOPMENT INC
FT. GEORGE G. MEADE

DOE-2.1D 6/ 7/1996 10:59:40 PDL RUN 1
EMCS FEASIBILITY STUDY
WEATHER FILE- BALTIMORE, MD

EQUIPMENT	NUMBER		NUMBER		NUMBER		NUMBER		NUMBER	
	SIZE	INSTD	SIZE	INSTD	SIZE	INSTD	SIZE	INSTD	SIZE	INSTD
	(MBTU/H)	AVAIL	(MBTU/H)	AVAIL	(MBTU/H)	AVAIL	(MBTU/H)	AVAIL	(MBTU/H)	AVAIL
HW-BOILER	2.400	2	2							

S I T E E N E R G Y													* SOURCE
MONTH	2	3	4	5	6	7	8	9	10	11	12	13	14
	TOTAL HEAT LOAD	TOTAL COOLING LOAD	TOTAL ELECTR LOAD	RCVRED ENERGY	WASTED RCVRABL ENERGY	FUEL INPUT COOLING	ELEC INPUT COOLING	FUEL INPUT HEATING	ELEC INPUT HEATING	FUEL INPUT ELECT	TOTAL FUEL INPUT	TOTAL SITE ENERGY	TOTAL SOURCE ENERGY
JAN	433.4	0.0	308.2 90.3E	0.0	0.0	0.0	0.0 0.0E	617.8	27.9 8.2E	0.0	617.8	926.0	1543.5
FEB	355.2	0.0	278.8 81.7E	0.0	0.0	0.0	0.0 0.0E	514.4	24.8 7.3E	0.0	514.4	793.2	1351.7
MAR	235.5	0.0	310.1 90.8E	0.0	0.0	0.0	0.0 0.0E	351.9	20.9 6.1E	0.0	351.9	662.0	1283.2
APR	111.7	0.0	277.9 81.4E	0.0	0.0	0.0	0.0 0.0E	174.8	14.5 4.2E	0.0	174.8	452.7	1009.3
MAY	0.0	0.0	343.4 100.6E	0.0	0.0	0.0	0.0 0.0E	0.0	0.0	0.0	0.0	343.4	1031.3
JUN	0.0	0.0	388.4 113.7E	0.0	0.0	0.0	0.0 0.0E	0.0	0.0	0.0	0.0	388.4	1166.3
JUL	0.0	0.0	392.7 115.0E	0.0	0.0	0.0	0.0 0.0E	0.0	0.0	0.0	0.0	392.7	1179.3
AUG	0.0	0.0	438.4 128.4E	0.0	0.0	0.0	0.0 0.0E	0.0	0.0	0.0	0.0	438.4	1316.7
SEP	0.0	0.0	366.6 107.4E	0.0	0.0	0.0	0.0 0.0E	0.0	0.0	0.0	0.0	366.6	1101.0
OCT	87.0	0.0	339.7 99.5E	0.0	0.0	0.0	0.0 0.0E	135.5	9.6 2.8E	0.0	135.5	475.3	1155.8
NOV	155.2	0.0	273.5 80.1E	0.0	0.0	0.0	0.0 0.0E	237.4	16.7 4.9E	0.0	237.4	510.8	1058.5
DEC	342.9	0.0	302.9 88.7E	0.0	0.0	0.0	0.0 0.0E	503.9	26.0 7.6E	0.0	503.9	806.7	1413.3
*****	1721.0	0.0	4020.7 1177.6E	0.0	0.0	0.0	0.0 0.0E	2535.7	140.4 41.1E	0.0	2535.7	6556.3	14609.8

NOTE-- ALL ENTRIES ARE IN MBTU EXCEPT
 ENTRIES FOLLOWED BY E ARE IN MWH (THOUSANDS OF KWH)

MO	UTILITY-	ELECTRICITY	FUEL-OIL
	TOTAL (MBTU)	308.241	617.808
JAN	PEAK (KBTU)	1061.289	2911.783
	DY/HR	31/17	17/10
	TOTAL (MBTU)	278.807	514.439
FEB	PEAK (KBTU)	1061.289	2842.216
	DY/HR	28/11	14/10
	TOTAL (MBTU)	310.119	351.887
MAR	PEAK (KBTU)	1061.289	2669.478
	DY/HR	31/ 7	7/ 8
	TOTAL (MBTU)	277.890	174.774
APR	PEAK (KBTU)	1061.289	2229.306
	DY/HR	28/ 7	4/ 7
	TOTAL (MBTU)	343.407	0.000
MAY	PEAK (KBTU)	1416.058	0.000
	DY/HR	26/16	31/ 1
	TOTAL (MBTU)	388.386	0.000
JUN	PEAK (KBTU)	1878.666	0.000
	DY/HR	29/16	30/ 1
	TOTAL (MBTU)	392.717	0.000
JUL	PEAK (KBTU)	1918.467	0.000
	DY/HR	25/14	31/ 1
	TOTAL (MBTU)	438.449	0.000
AUG	PEAK (KBTU)	1899.375	0.000
	DY/HR	18/17	31/ 1
	TOTAL (MBTU)	366.630	0.000
SEP	PEAK (KBTU)	1852.877	0.000
	DY/HR	2/14	30/ 1
	TOTAL (MBTU)	339.741	135.523
OCT	PEAK (KBTU)	1442.840	2142.930
	DY/HR	18/16	24/ 7
	TOTAL (MBTU)	273.451	237.364
NOV	PEAK (KBTU)	1061.289	2495.078
	DY/HR	30/10	25/ 7
	TOTAL (MBTU)	302.851	503.858
DEC	PEAK (KBTU)	1061.289	2703.477
	DY/HR	30/ 9	12/ 8
	ONE YEAR	4020.690	2535.652
	USE/PEAK	1918.467	2911.783

ENTECH ENGINEERING
READING, PA 19603
REPORT- PS-D PLANT LOADS SATISFIED

EZDOE - ELITE SOFTWARE DEVELOPMENT INC
FT. GEORGE G. MEADE

DOE-2.1D 6/ 7/1996 10:59:40 PDL RUN 1
EMCS FEASIBILITY STUDY
WEATHER FILE- BALTIMORE, MD

HEATING LOADS	MBTU SUPPLIED	PCT OF TOTAL LOAD
-----	-----	-----
HW-BOILER	1721.1	100.0
	=====	=====
LOAD SATISFIED	1721.1	100.0
TOTAL LOAD ON PLANT	1721.1	

ELECTRICAL LOADS	MBTU SUPPLIED	PCT OF TOTAL LOAD
-----	-----	-----
ELECTRICITY	4020.7	100.0
	=====	=====
LOAD SATISFIED	4020.7	100.0
TOTAL LOAD ON PLANT	4020.7	

ENTECH ENGINEERING
READING, PA 19603
REPORT- PS-D PLANT LOADS SATISFIED

BZDOE - ELITE SOFTWARE DEVELOPMENT INC
FT. GEORGE G. MEADE

DOB-2.1D 6/ 7/1996 10:59:40 PDL RUN 1
EMCS FEASIBILITY STUDY
WEATHER FILE- BALTIMORE, MD
----- (CONTINUED) -----

SUMMARY OF LOADS MET

TYPE OF LOAD	TOTAL LOAD (MBTU)	LOAD SATISFIED (MBTU)	TOTAL OVERLOAD (MBTU)	PEAK OVERLOAD (MBTU)	HOURS OVERLOADED
HEATING LOADS	1721.1	1721.1	0.000	0.000	0
ELECTRICAL LOADS	4020.7	4020.7	0.000	0.000	0

EQUIPMENT	AVG OPER RATIO	MAX LOAD (MBTU)	-----		-----		-----		-----		-----	
			MON DAY HR	SIZE (MBTU)	OPER HRS	SIZE (MBTU)	OPER HRS	SIZE (MBTU)	OPER HRS	SIZE (MBTU)	OPER HRS	
HW-BOILER	0.152	2.316	1	17	10	2.400	4728					

ENVECH ENGINEERING
READING, PA 19603
REPORT- PS-I EQUIPMENT LIFE CYCLE COSTS

EZDOE - ELITE SOFTWARE DEVELOPMENT INC
FT. GEORGE G. MEADE

DOE-2.1D 6/ 7/1996 10:59:40 PDL RUN 1
EMCS FEASIBILITY STUDY
WEATHER FILE- BALTIMORE, MD

E Q U I P M E N T T O T A L S

HW-BOILER	137.0		
NOMINAL SIZE (MBTU)		2.400	
NUMBER INSTALLED			2
FIRST COST (K\$)	127.5	127.5	
ANNUAL COST (K\$)	4.1	4.1	
CYCLICAL COST (K\$)	5.3	5.3	
-----TOTAL----- (K\$)			137.0

EQUIPMENT TOTAL	137.0		

ENERGY TYPE		
IN SITE MBTU -	ELECTRICITY	FUEL-OIL
CATEGORY OF USE		
SPACE HEAT	100.07	2535.70
SPACE COOL	565.50	0.00
HVAC AUX	785.91	0.00
DOM HOT WTR	0.00	0.00
AUX SOLAR	0.00	0.00
LIGHTS	1701.34	0.00
VERT TRANS	0.00	0.00
MISC EQUIP	867.89	0.00
	-----	-----
TOTAL	4020.71	2535.70

TOTAL SITE ENERGY 6556.34 MBTU 73.2 KBTU/SQFT-YR GROSS-AREA 73.2 KBTU/SQFT-YR NET-AREA
 TOTAL SOURCE ENERGY 14609.80 MBTU 163.2 KBTU/SQFT-YR GROSS-AREA 163.2 KBTU/SQFT-YR NET-AREA

PERCENT OF HOURS ANY SYSTEM ZONE OUTSIDE OF THROTTLING RANGE = 34.9
 PERCENT OF HOURS ANY PLANT LOAD NOT SATISFIED = 0.0

NOTE ELECTRICITY AND/OR FUEL USED TO GENERATE ELECTRICITY IS APPORTIONED BASED
 ON THE YEARLY DEMAND. ALL OTHER ENERGY TYPES ARE APPORTIONED HOURLY.

MDDHH	HW-BOILE R LOAD BTU/HR	HW-BOILE R ELECTRIC USE BTU/HR	HW-BOILE R FUEL USE BTU/HR
	----(1)	----(3)	----(4)
MONTHLY SUMMARY (JAN)			
MN	15328.	1349.	25049.
MK	2316066.	52800.	2911783.
SM	433442016.	21513318.	617807040.
AV	582583.	28916.	830386.
MONTHLY SUMMARY (FEB)			
MN	15328.	1349.	25049.
MK	2250264.	52800.	2842216.
SM	355209536.	19092220.	514437408.
AV	528586.	28411.	765532.
MONTHLY SUMMARY (MAR)			
MN	15328.	1349.	25049.
MK	2088315.	52800.	2669478.
SM	235524048.	14504834.	351885056.
AV	316565.	19496.	472964.
MONTHLY SUMMARY (APR)			
MN	15328.	1349.	25049.
MK	1684491.	52800.	2229306.
SM	111721800.	8345980.	174773376.
AV	155169.	11592.	242741.
MONTHLY SUMMARY (OCT)			
MN	15328.	1349.	25049.
MK	1606669.	52800.	2142930.
SM	87024832.	6369380.	135523472.
AV	226627.	16587.	352926.
MONTHLY SUMMARY (NOV)			
MN	15328.	1349.	25049.
MK	1926833.	52800.	2495078.
SM	155239792.	10569000.	237363840.
AV	215611.	14679.	329672.
MONTHLY SUMMARY (DEC)			
MN	15328.	1349.	25049.
MK	2120030.	52800.	2703477.
SM	342866112.	19676782.	503856064.
AV	460842.	26447.	677226.

ENTECH ENGINEERING
READING, PA 19603
= HOURLY-REPORT

EZDOR - ELITE SOFTWARE DEVELOPMENT INC
FT. GEORGE G. MEADE

DOE-2.1D 6/ 7/1996 10:59:40 PDL RUN 1
EMCS FEASIBILITY STUDY

PAGE 2- 1

HW-BOILE HW-BOILE HW-BOILE
R R R
LOAD ELECTRIC FUEL
USE USE
BTU/HR BTU/HR BTU/HR
----(1) ----(3) ----(4)

YEARLY SUMMARY

MN	15328.	1349.	25049.
MX	2316066.	52800.	2911783.
SM	1721028096.	100071512.	2535646208.
AV	364008.	21166.	536304.

ENTECH ENGINEERING READING, PA 19603 = HOURLY-REPORT			EZDOE - ELITE SOFTWARE DEVELOPMENT INC FT. GEORGE G. MEADE			DOE-2.1D 6/7/1996 EMCS FEASIBILITY STUDY		
						11:10:2 SDL RUN 1		
						PAGE 1- 1		
MDDHH	AC-1	AC-1	AC-1	AC-1	AC-1	AC-2	AC-2	AC-2
	TOT HTG COIL PWR BTU/HR	SUPPLY ELECTRIC KW	HEATING CAPACITY BTU/HR	COOLING ELECTRIC KW	COOLING CAPACITY BTU/HR	TOT HTG COIL PWR BTU/HR	SUPPLY ELECTRIC KW	HEATING CAPACITY BTU/HR
	---- (5)	---- (49)	---- (78)	---- (47)	---- (70)	---- (5)	---- (49)	---- (78)
MONTHLY SUMMARY (JAN)								
MN	-122513.	2.870	-151831.	0.000	150178.	-278846.	6.928	-366439.
MX	-22460.	2.870	-151831.	0.000	150178.	-15845.	6.928	-366439.
SM	-14558187.	723.341	-38261468.	0.000	37844976.	-26230990.	1745.755	-92342552.
AV	-57771.	2.870	-151831.	0.000	150178.	-104091.	6.928	-366439.
MONTHLY SUMMARY (FEB)								
MN	-127935.	2.870	-151831.	0.000	150178.	-275195.	6.928	-366439.
MX	-28770.	2.870	-151831.	0.000	151460.	-355.	6.928	-366439.
SM	-15530583.	654.451	-34617516.	0.000	34242716.	-20591042.	1579.493	-83548024.
AV	-68117.	2.870	-151831.	0.000	150187.	-90312.	6.928	-366439.
MONTHLY SUMMARY (MAR)								
MN	-126765.	2.870	-151831.	0.000	146460.	-259816.	6.928	-366439.
MX	-28543.	2.870	-151831.	0.000	156294.	-11.	6.928	-366439.
SM	-18375168.	792.231	-41905420.	0.000	41453336.	-12703316.	1912.018	-101137080.
AV	-66577.	2.870	-151831.	0.000	150193.	-46027.	6.928	-366439.
MONTHLY SUMMARY (APR)								
MN	-123884.	2.870	-151831.	0.000	140666.	-187313.	6.928	-366439.
MX	-18200.	2.870	-151831.	0.000	160440.	0.	6.928	-366439.
SM	-14890816.	723.341	-38261468.	0.000	37896252.	-3823463.	1745.755	-92342552.
AV	-59091.	2.870	-151831.	0.000	150382.	-15172.	6.928	-366439.
MONTHLY SUMMARY (MAY)								
MN	0.	2.870	0.	0.000	137842.	0.	6.928	0.
MX	0.	2.870	0.	0.000	170622.	0.	6.928	0.
SM	0.	723.341	0.	0.000	38297576.	0.	1745.755	0.
AV	0.	2.870	0.	0.000	151975.	0.	6.928	0.
MONTHLY SUMMARY (JUN)								
MN	0.	2.870	0.	0.000	135757.	0.	6.928	0.
MX	0.	2.870	0.	5.807	234683.	0.	6.928	0.
SM	0.	757.786	0.	315.831	41412312.	0.	1828.887	0.
AV	0.	2.870	0.	1.196	156865.	0.	6.928	0.
MONTHLY SUMMARY (JUL)								
MN	0.	2.870	0.	0.000	139955.	0.	6.928	0.
MX	0.	2.870	0.	7.844	205800.	0.	6.928	0.
SM	0.	688.896	0.	1068.037	36831840.	0.	1662.624	0.
AV	0.	2.870	0.	4.450	153466.	0.	6.928	0.

	AC-1	AC-1	AC-1	AC-1	AC-1	AC-2	AC-2	AC-2
	TOT HTG COIL PWR BTU/HR	SUPPLY ELECTRIC KW	HEATING CAPACITY BTU/HR	COOLING ELECTRIC KW	COOLING CAPACITY BTU/HR	TOT HTG COIL PWR BTU/HR	SUPPLY ELECTRIC KW	HEATING CAPACITY BTU/HR
	---- (5)	----(49)	----(78)	----(47)	----(70)	----(5)	----(49)	----(78)
MONTHLY SUMMARY (AUG)								
MN	0.	2.870	0.	0.000	139372.	0.	6.928	0.
MX	0.	2.870	0.	9.335	176418.	0.	6.928	0.
SM	0.	792.231	0.	1663.538	41517772.	0.	1912.018	0.
AV	0.	2.870	0.	6.027	150427.	0.	6.928	0.
MONTHLY SUMMARY (SEP)								
MN	0.	2.870	0.	0.000	138868.	0.	6.928	0.
MX	0.	2.870	0.	9.443	160750.	0.	6.928	0.
SM	0.	723.341	0.	1201.231	38042244.	0.	1745.755	0.
AV	0.	2.870	0.	4.767	150961.	0.	6.928	0.
MONTHLY SUMMARY (OCT)								
MN	-42732.	2.870	-151831.	0.000	144265.	-173598.	6.928	-366439.
MX	0.	2.870	0.	8.071	170027.	0.	6.928	0.
SM	-1705064.	688.896	-20041722.	1035.685	36506816.	-8617323.	1662.624	-48369908.
AV	-7104.	2.870	-83507.	4.315	152112.	-35906.	6.928	-201541.
MONTHLY SUMMARY (NOV)								
MN	-102575.	2.870	-151831.	0.000	150178.	-230286.	6.928	-366439.
MX	-13.	2.870	-151831.	0.000	179299.	0.	6.928	-366439.
SM	-2513569.	688.896	-36439492.	0.000	36677552.	-10586555.	1662.624	-87945288.
AV	-10473.	2.870	-151831.	0.000	152823.	-44111.	6.928	-366439.
MONTHLY SUMMARY (DEC)								
MN	-117214.	2.870	-151831.	0.000	150178.	-254841.	6.928	-366439.
MX	-1156.	2.870	-151831.	0.000	154304.	-5688.	6.928	-366439.
SM	-8868925.	723.341	-38261468.	0.000	37863124.	-22732352.	1745.755	-92342552.
AV	-35194.	2.870	-151831.	0.000	150250.	-90208.	6.928	-366439.
YEARLY SUMMARY								
MN	-127935.	2.870	-151831.	0.000	135757.	-278846.	6.928	-366439.
MX	0.	2.870	0.	9.443	234683.	0.	6.928	0.
SM	-76442312.	8680.091	-247788560.	5284.321	458586528.	-105285040.	20949.066	-598027968.
AV	-25279.	2.870	-81941.	1.747	151649.	-34816.	6.928	-197761.

MMDDHR	AC-2	AC-2	AC-3	AC-3	AC-3	AC-3	AC-3	AC-4
	COOLING ELECTRIC KW	COOLING CAPACITY BTU/HR	TOT HTG COIL PWR BTU/HR	SUPPLY ELECTRIC KW	HEATING CAPACITY BTU/HR	COOLING ELECTRIC KW	COOLING CAPACITY BTU/HR	TOT HTG COIL PWR BTU/HR
	----(47)	----(70)	----(5)	----(49)	----(78)	----(47)	----(70)	----(5)
MONTHLY SUMMARY (JAN)								
MN	0.000	375976.	-278617.	6.877	-366218.	0.000	376161.	-345109.
MX	0.000	898662.	-15723.	6.877	-366218.	0.000	899129.	-44579.
SM	0.000	103709464.	-26183250.	1733.105	-92287048.	0.000	103766072.	-40758408.
AV	0.000	411546.	-103902.	6.877	-366218.	0.000	411770.	-161740.
MONTHLY SUMMARY (FEB)								
MN	0.000	375976.	-274967.	6.877	-366218.	0.000	376161.	-340333.
MX	0.000	581469.	-322.	6.877	-366218.	0.000	581791.	-2600.
SM	0.000	91682136.	-20549280.	1568.047	-83497800.	0.000	91733008.	-31746240.
AV	0.000	402115.	-90128.	6.877	-366218.	0.000	402338.	-139238.
MONTHLY SUMMARY (MAR)								
MN	0.000	375976.	-259589.	6.877	-366218.	0.000	376161.	-330232.
MX	0.000	691458.	-11.	6.877	-366218.	0.000	691857.	-12.
SM	0.000	114108192.	-12650231.	1898.163	-101076296.	0.000	114172824.	-23319202.
AV	0.000	413435.	-45834.	6.877	-366218.	0.000	413670.	-84490.
MONTHLY SUMMARY (APR)								
MN	0.000	374094.	-187031.	6.877	-366218.	0.000	374283.	-236368.
MX	0.000	682066.	0.	6.877	-366218.	0.000	682436.	-2.
SM	0.000	110574344.	-3806488.	1733.105	-92287048.	0.000	110643736.	-8667362.
AV	0.000	438787.	-15105.	6.877	-366218.	0.000	439062.	-34394.
MONTHLY SUMMARY (MAY)								
MN	0.000	347057.	0.	6.877	0.	0.000	347268.	0.
MX	18.390	611077.	0.	6.877	0.	18.410	611415.	0.
SM	1860.563	102494904.	0.	1733.105	0.	1863.265	102559656.	0.
AV	7.383	406726.	0.	6.877	0.	7.394	406983.	0.
MONTHLY SUMMARY (JUN)								
MN	0.000	345043.	0.	6.877	0.	0.000	345241.	0.
MX	29.989	504729.	0.	6.877	0.	30.011	505017.	0.
SM	4417.069	101308600.	0.	1815.634	0.	4422.421	101259984.	0.
AV	16.731	383745.	0.	6.877	0.	16.752	383561.	0.
MONTHLY SUMMARY (JUL)								
MN	10.019	351272.	0.	6.877	0.	10.030	351471.	0.
MX	31.783	406914.	0.	6.877	0.	31.806	407143.	0.
SM	5106.503	90529160.	0.	1650.576	0.	5111.282	90580488.	0.
AV	21.277	377205.	0.	6.877	0.	21.297	377419.	0.

	AC-2	AC-2	AC-3	AC-3	AC-3	AC-3	AC-3	AC-4
	COOLING ELECTRIC KW	COOLING CAPACITY BTU/HR	TOT HTG COIL PWR BTU/HR	SUPPLY ELECTRIC KW	HEATING CAPACITY BTU/HR	COOLING ELECTRIC KW	COOLING CAPACITY BTU/HR	TOT HTG COIL PWR BTU/HR
	----(47)	----(70)	----(5)	----(49)	----(78)	----(47)	----(70)	----(5)
MONTHLY SUMMARY (AUG)								
MN	0.000	350722.	0.	6.877	0.	0.000	350921.	0.
MK	29.415	565910.	0.	6.877	0.	29.438	566228.	0.
SM	5478.544	104365752.	0.	1898.163	0.	5488.067	104417624.	0.
AV	19.850	378137.	0.	6.877	0.	19.884	378325.	0.
MONTHLY SUMMARY (SEP)								
MN	0.000	347271.	0.	6.877	0.	0.000	347469.	0.
MK	27.628	630836.	0.	6.877	0.	27.651	631182.	0.
SM	3464.644	100404384.	0.	1733.105	0.	3477.184	100451680.	0.
AV	13.749	398430.	0.	6.877	0.	13.798	398618.	0.
MONTHLY SUMMARY (OCT)								
MN	0.000	368444.	-173426.	6.877	-366218.	0.000	368657.	-244242.
MK	17.154	554272.	0.	6.877	0.	17.175	554613.	0.
SM	2310.761	94750872.	-8605528.	1650.576	-48340824.	2313.815	94804408.	-14058561.
AV	9.628	394795.	-35856.	6.877	-201420.	9.641	395018.	-58577.
MONTHLY SUMMARY (NOV)								
MN	0.000	375976.	-230056.	6.877	-366218.	0.000	376161.	-286595.
MK	0.000	598107.	0.	6.877	-366218.	0.000	598442.	0.
SM	0.000	102814144.	-10556678.	1650.576	-87892424.	0.000	102874736.	-18995024.
AV	0.000	428392.	-43986.	6.877	-366218.	0.000	428645.	-79146.
MONTHLY SUMMARY (DEC)								
MN	0.000	375976.	-254615.	6.877	-366218.	0.000	376161.	-320379.
MK	0.000	588884.	-5621.	6.877	-366218.	0.000	589211.	-20436.
SM	0.000	102830928.	-22685996.	1733.105	-92287048.	0.000	102888392.	-36020888.
AV	0.000	408059.	-90024.	6.877	-366218.	0.000	408287.	-142940.
YEARLY SUMMARY								
MN	0.000	345043.	-278617.	6.877	-366218.	0.000	345241.	-345109.
MK	31.783	898662.	0.	6.877	0.	31.806	899129.	0.
SM	22638.086	1219572864.	-105037456.	20797.262	-597668480.	22676.033	1220152576.	-173565696.
AV	7.486	403298.	-34735.	6.877	-197642.	7.499	403490.	-57396.

MMDDHH	AC-4	AC-4	AC-4	AC-4	AC-5	AC-5	AC-5	AC-5
	SUPPLY ELECTRIC KW	HEATING CAPACITY BTU/HR	COOLING ELECTRIC KW	COOLING CAPACITY BTU/HR	TOT HTG COIL PWR BTU/HR	SUPPLY ELECTRIC KW	HEATING CAPACITY BTU/HR	COOLING ELECTRIC KW
	---- (49)	---- (78)	---- (47)	---- (70)	---- (5)	---- (49)	---- (78)	---- (47)
MONTHLY SUMMARY (JAN)								
MN	8.843	-470904.	0.000	468582.	-122415.	2.850	-151740.	0.000
MX	8.843	-470904.	0.000	1119192.	-22390.	2.850	-151740.	0.000
SM	2228.525	-118667936.	0.000	129165640.	-14537181.	718.099	-38238452.	0.000
AV	8.843	-470905.	0.000	512562.	-57687.	2.850	-151740.	0.000
MONTHLY SUMMARY (FEB)								
MN	8.843	-470904.	0.000	468582.	-127838.	2.850	-151740.	0.000
MX	8.843	-470904.	0.000	724454.	-28694.	2.850	-151740.	0.000
SM	2016.284	-107366224.	0.000	114186944.	-15510692.	649.709	-34596692.	0.000
AV	8.843	-470905.	0.000	500820.	-68029.	2.850	-151740.	0.000
MONTHLY SUMMARY (MAR)								
MN	8.843	-470904.	0.000	468582.	-126667.	2.850	-151740.	0.000
MX	8.843	-470904.	0.000	860793.	-28467.	2.850	-151740.	0.000
SM	2440.765	-129969648.	0.000	141867600.	-18350924.	786.490	-41880212.	0.000
AV	8.843	-470905.	0.000	514013.	-66489.	2.850	-151740.	0.000
MONTHLY SUMMARY (APR)								
MN	8.843	-470904.	0.000	464229.	-123787.	2.850	-151740.	0.000
MX	8.843	-470904.	0.000	850018.	-18123.	2.850	-151740.	0.000
SM	2228.525	-118667936.	0.000	136727184.	-14868943.	718.099	-38238452.	0.000
AV	8.843	-470905.	0.000	542568.	-59004.	2.850	-151740.	0.000
MONTHLY SUMMARY (MAY)								
MN	8.843	0.	0.000	432383.	0.	2.850	0.	0.000
MX	8.843	0.	22.151	760046.	0.	2.850	0.	0.000
SM	2228.525	0.	1859.570	127801712.	0.	718.099	0.	0.000
AV	8.843	0.	7.379	507150.	0.	2.850	0.	0.000
MONTHLY SUMMARY (JUN)								
MN	8.843	0.	0.000	429926.	0.	2.850	0.	0.000
MX	8.843	0.	36.989	628243.	0.	2.850	0.	5.815
SM	2334.645	0.	4969.541	126046168.	0.	752.294	0.	318.563
AV	8.843	0.	18.824	477448.	0.	2.850	0.	1.207
MONTHLY SUMMARY (JUL)								
MN	8.843	0.	9.598	434706.	0.	2.850	0.	0.000
MX	8.843	0.	38.721	505207.	0.	2.850	0.	7.857
SM	2122.405	0.	5779.993	112596632.	0.	683.904	0.	1071.663
AV	8.843	0.	24.083	469153.	0.	2.850	0.	4.465

	AC-4	AC-4	AC-4	AC-4	AC-5	AC-5	AC-5	AC-5
	SUPPLY ELECTRIC KW	HEATING CAPACITY BTU/HR	COOLING ELECTRIC KW	COOLING CAPACITY BTU/HR	TOT HTG COIL PWR BTU/HR	SUPPLY ELECTRIC KW	HEATING CAPACITY BTU/HR	COOLING ELECTRIC KW
	----(49)	----(78)	----(47)	----(70)	----(5)	----(49)	----(78)	----(47)
MONTHLY SUMMARY (AUG)								
MN	8.843	0.	0.000	434790.	0.	2.850	0.	0.000
MK	8.843	0.	35.424	703995.	0.	2.850	0.	9.346
SM	2440.765	0.	6165.837	130006816.	0.	786.490	0.	1666.638
AV	8.843	0.	22.340	471039.	0.	2.850	0.	6.039
MONTHLY SUMMARY (SEP)								
MN	8.843	0.	0.000	431516.	0.	2.850	0.	0.000
MK	8.843	0.	33.738	785401.	0.	2.850	0.	9.454
SM	2228.525	0.	3706.945	125941336.	0.	718.099	0.	1203.595
AV	8.843	0.	14.710	499767.	0.	2.850	0.	4.776
MONTHLY SUMMARY (OCT)								
MN	8.843	-470904.	0.000	457812.	-42679.	2.850	-151740.	0.000
MK	8.843	0.	19.513	683905.	0.	2.850	0.	8.079
SM	2122.405	-62159376.	2467.324	118610000.	-1702237.	683.904	-20029666.	1037.320
AV	8.843	-258997.	10.281	494208.	-7093.	2.850	-83457.	4.322
MONTHLY SUMMARY (NOV)								
MN	8.843	-470904.	0.000	468582.	-102463.	2.850	-151740.	0.000
MK	8.843	-470904.	0.000	744451.	-13.	2.850	-151740.	0.000
SM	2122.405	-113017080.	0.000	127613176.	-2505052.	683.904	-36417572.	0.000
AV	8.843	-470905.	0.000	531722.	-10438.	2.850	-151740.	0.000
MONTHLY SUMMARY (DEC)								
MN	8.843	-470904.	0.000	468582.	-117116.	2.850	-151740.	0.000
MK	8.843	-470904.	0.000	733076.	-1084.	2.850	-151740.	0.000
SM	2228.525	-118667936.	0.000	128057712.	-8849899.	718.099	-38238452.	0.000
AV	8.843	-470905.	0.000	508166.	-35119.	2.850	-151740.	0.000
YEARLY SUMMARY								
MN	8.843	-470904.	0.000	429926.	-127838.	2.850	-151740.	0.000
MK	8.843	0.	38.721	1119192.	0.	2.850	0.	9.454
SM	26742.297	-768516096.	24949.211	1518620928.	-76324928.	8617.189	-247639488.	5297.778
AV	8.843	-254139.	8.250	502189.	-25240.	2.850	-81891.	1.752

MMDDHH	AC-5	AC-6	AC-6	AC-6	AC-6	AC-6	AC-7	AC-7
	COOLING CAPACITY BTU/HR	TOT HTG COIL PWR BTU/HR	SUPPLY ELECTRIC KW	HEATING CAPACITY BTU/HR	COOLING ELECTRIC KW	COOLING CAPACITY BTU/HR	TOT HTG COIL PWR BTU/HR	SUPPLY ELECTRIC KW
	----(70)	----(5)	----(49)	----(78)	----(47)	----(70)	----(5)	----(49)
MONTHLY SUMMARY (JAN)								
MN	150255.	-256422.	6.617	-352358.	0.000	364832.	-256422.	6.617
MX	150255.	-20130.	6.617	-352358.	0.000	871725.	-20130.	6.617
SM	37864352.	-27782360.	1667.510	-88794096.	0.000	100603696.	-27782360.	1667.510
AV	150255.	-110247.	6.617	-352358.	0.000	399221.	-110247.	6.617
MONTHLY SUMMARY (FEB)								
MN	150255.	-268093.	6.617	-352358.	0.000	364832.	-268093.	6.617
MX	151554.	-2533.	6.617	-352358.	0.000	564789.	-2533.	6.617
SM	34260300.	-22202782.	1508.699	-80337520.	0.000	88928920.	-22202782.	1508.699
AV	150264.	-97381.	6.617	-352358.	0.000	390039.	-97381.	6.617
MONTHLY SUMMARY (MAR)								
MN	146535.	-262840.	6.617	-352358.	0.000	364832.	-262840.	6.617
MX	156391.	-13.	6.617	-352358.	0.000	669029.	-13.	6.617
SM	41474716.	-14623035.	1826.321	-97250672.	0.000	110538360.	-14623035.	1826.321
AV	150271.	-52982.	6.617	-352358.	0.000	400501.	-52982.	6.617
MONTHLY SUMMARY (APR)								
MN	140738.	-197794.	6.617	-352358.	0.000	359557.	-197794.	6.617
MX	160540.	-2.	6.617	-352358.	0.000	661651.	-2.	6.617
SM	37916076.	-4665266.	1667.510	-88794096.	0.000	106816448.	-4665266.	1667.510
AV	150461.	-18513.	6.617	-352358.	0.000	423875.	-18513.	6.617
MONTHLY SUMMARY (MAY)								
MN	137912.	0.	6.617	0.	0.000	336646.	0.	6.617
MX	170747.	0.	6.617	0.	16.783	592591.	0.	6.617
SM	38319960.	0.	1667.510	0.	1646.621	99714048.	0.	1667.510
AV	152063.	0.	6.617	0.	6.534	395691.	0.	6.617
MONTHLY SUMMARY (JUN)								
MN	135851.	0.	6.617	0.	0.000	334559.	0.	6.617
MX	226355.	0.	6.617	0.	28.352	489638.	0.	6.617
SM	41394540.	0.	1746.915	0.	4062.474	98608984.	0.	1746.915
AV	156798.	0.	6.617	0.	15.388	373519.	0.	6.617
MONTHLY SUMMARY (JUL)								
MN	140027.	0.	6.617	0.	9.781	340893.	0.	6.617
MX	201356.	0.	6.617	0.	30.141	394917.	0.	6.617
SM	36841568.	0.	1588.105	0.	4754.968	87951088.	0.	1588.105
AV	153507.	0.	6.617	0.	19.812	366463.	0.	6.617

	AC-5	AC-6	AC-6	AC-6	AC-6	AC-6	AC-7	AC-7
	COOLING CAPACITY BTU/HR	TOT HTG COIL PWR BTU/HR	SUPPLY ELECTRIC KW	HEATING CAPACITY BTU/HR	COOLING ELECTRIC KW	COOLING CAPACITY BTU/HR	TOT HTG COIL PWR BTU/HR	SUPPLY ELECTRIC KW
	----(70)	----(5)	----(49)	----(78)	----(47)	----(70)	----(5)	----(49)
MONTHLY SUMMARY (AUG)								
MN	139454.	0.	6.617	0.	0.000	340344.	0.	6.617
MX	175885.	0.	6.617	0.	27.846	548885.	0.	6.617
SM	41540572.	0.	1826.321	0.	5052.518	101421304.	0.	1826.321
AV	150509.	0.	6.617	0.	18.306	367469.	0.	6.617
MONTHLY SUMMARY (SEP)								
MN	138950.	0.	6.617	0.	0.000	337040.	0.	6.617
MX	160850.	0.	6.617	0.	25.936	611916.	0.	6.617
SM	38064080.	0.	1667.510	0.	3127.630	98028936.	0.	1667.510
AV	151048.	0.	6.617	0.	12.411	389004.	0.	6.617
MONTHLY SUMMARY (OCT)								
MN	144338.	-181514.	6.617	-352358.	0.000	358031.	-181514.	6.617
MX	169433.	0.	6.617	0.	15.674	537198.	0.	6.617
SM	36526100.	-9231696.	1588.105	-46511200.	2081.722	92526800.	-9231696.	1588.105
AV	152192.	-38465.	6.617	-193797.	8.674	385528.	-38465.	6.617
MONTHLY SUMMARY (NOV)								
MN	150255.	-249730.	6.617	-352358.	0.000	364832.	-249730.	6.617
MX	179410.	-1.	6.617	-352358.	0.000	580060.	-1.	6.617
SM	36697212.	-12001809.	1588.105	-84565808.	0.000	99550160.	-12001809.	1588.105
AV	152905.	-50008.	6.617	-352358.	0.000	414792.	-50008.	6.617
MONTHLY SUMMARY (DEC)								
MN	150255.	-257145.	6.617	-352358.	0.000	364832.	-257145.	6.617
MX	154400.	-7410.	6.617	-352358.	0.000	571209.	-7410.	6.617
SM	37882648.	-24346456.	1667.510	-88794096.	0.000	99739328.	-24346456.	1667.510
AV	150328.	-96613.	6.617	-352358.	0.000	395791.	-96613.	6.617
YEARLY SUMMARY								
MN	135851.	-268093.	6.617	-352358.	0.000	334559.	-268093.	6.617
MX	226355.	0.	6.617	0.	30.141	871725.	0.	6.617
SM	458782144.	-114853408.	20010.119	-575047488.	20725.934	1184428032.	-114853408.	20010.119
AV	151714.	-37981.	6.617	-190161.	6.854	391676.	-37981.	6.617

MDDDH	AC-7	AC-7	AC-7	AC-8	AC-8	AC-8	AC-8	AC-8
	HEATING CAPACITY BTU/HR	COOLING ELECTRIC KW	COOLING CAPACITY BTU/HR	TOT HTG COIL PWR BTU/HR	SUPPLY ELECTRIC KW	HEATING CAPACITY BTU/HR	COOLING ELECTRIC KW	COOLING CAPACITY BTU/HR
	----(78)	----(47)	----(70)	----(5)	----(49)	----(78)	----(47)	----(70)
MONTHLY SUMMARY (JAN)								
MN	-352358.	0.000	364832.	-346996.	8.901	-470823.	0.000	467995.
MX	-352358.	0.000	871725.	-56327.	8.901	-470823.	0.000	1117615.
SM	-88794096.	0.000	100603696.	-42739120.	2243.052	-118647312.	0.000	128975128.
AV	-352358.	0.000	399221.	-169600.	8.901	-470823.	0.000	511806.
MONTHLY SUMMARY (FEB)								
MN	-352358.	0.000	364832.	-343277.	8.901	-470823.	0.000	467995.
MX	-352358.	0.000	564789.	-5824.	8.901	-470823.	0.000	723354.
SM	-80337520.	0.000	88928920.	-33801908.	2029.428	-107347568.	0.000	114007576.
AV	-352358.	0.000	390039.	-148254.	8.901	-470823.	0.000	500033.
MONTHLY SUMMARY (MAR)								
MN	-352358.	0.000	364832.	-336787.	8.901	-470823.	0.000	467995.
MX	-352358.	0.000	669029.	-13.	8.901	-470823.	0.000	859550.
SM	-97250672.	0.000	110538360.	-25893804.	2456.676	-129947056.	0.000	141590304.
AV	-352358.	0.000	400501.	-93818.	8.901	-470823.	0.000	513008.
MONTHLY SUMMARY (APR)								
MN	-352358.	0.000	359557.	-244913.	8.901	-470823.	0.000	460471.
MX	-352358.	0.000	661651.	-4.	8.901	-470823.	0.000	848730.
SM	-88794096.	0.000	106816448.	-10090045.	2243.052	-118647312.	0.000	136199632.
AV	-352358.	0.000	423875.	-40040.	8.901	-470823.	0.000	540475.
MONTHLY SUMMARY (MAY)								
MN	0.	0.000	336646.	0.	8.901	0.	0.000	431561.
MX	0.	16.783	592591.	0.	8.901	0.	20.682	758563.
SM	0.	1646.621	99714048.	0.	2243.052	0.	1681.575	128176640.
AV	0.	6.534	395691.	0.	8.901	0.	6.673	508637.
MONTHLY SUMMARY (JUN)								
MN	0.	0.000	334559.	0.	8.901	0.	0.000	428701.
MX	0.	28.352	489638.	0.	8.901	0.	35.844	671227.
SM	0.	4062.474	98608984.	0.	2349.864	0.	4654.578	126909336.
AV	0.	15.388	373519.	0.	8.901	0.	17.631	480717.
MONTHLY SUMMARY (JUL)								
MN	0.	9.781	340893.	0.	8.901	0.	6.311	433373.
MX	0.	30.141	394917.	0.	8.901	0.	37.654	497074.
SM	0.	4754.968	87951088.	0.	2136.240	0.	5468.486	112534976.
AV	0.	19.812	366463.	0.	8.901	0.	22.785	468896.

	AC-7	AC-7	AC-7	AC-8	AC-8	AC-8	AC-8	AC-8
	HEATING CAPACITY BTU/HR	COOLING ELECTRIC KW	COOLING CAPACITY BTU/HR	TOT HTG COIL PWR BTU/HR	SUPPLY ELECTRIC KW	HEATING CAPACITY BTU/HR	COOLING ELECTRIC KW	COOLING CAPACITY BTU/HR
	----(78)	----(47)	----(70)	----(5)	----(49)	----(78)	----(47)	----(70)
MONTHLY SUMMARY (AUG)								
MN	0.	0.000	340344.	0.	8.901	0.	0.000	434089.
MK	0.	27.846	548885.	0.	8.901	0.	34.177	702758.
SM	0.	5052.518	101421304.	0.	2456.676	0.	5806.130	129778648.
AV	0.	18.306	367469.	0.	8.901	0.	21.037	470213.
MONTHLY SUMMARY (SEP)								
MN	0.	0.000	337040.	0.	8.901	0.	0.000	431012.
MK	0.	25.936	611916.	0.	8.901	0.	32.380	783929.
SM	0.	3127.630	98028936.	0.	2243.052	0.	3436.271	126279136.
AV	0.	12.411	389004.	0.	8.901	0.	13.636	501108.
MONTHLY SUMMARY (OCT)								
MN	-352358.	0.000	358031.	-260097.	8.901	-470823.	0.000	457455.
MK	0.	15.674	537198.	0.	8.901	0.	18.733	715110.
SM	-46511200.	2081.722	92526800.	-15084482.	2136.240	-62148592.	2292.610	119054184.
AV	-193797.	8.674	385528.	-62852.	8.901	-258952.	9.553	496059.
MONTHLY SUMMARY (NOV)								
MN	-352358.	0.000	364832.	-293309.	8.901	-470823.	0.000	467995.
MK	-352358.	0.000	580060.	-2.	8.901	-470823.	0.000	743268.
SM	-84565808.	0.000	99550160.	-20658266.	2136.240	-112997440.	0.000	127267536.
AV	-352358.	0.000	414792.	-86076.	8.901	-470823.	0.000	530281.
MONTHLY SUMMARY (DEC)								
MN	-352358.	0.000	364832.	-332664.	8.901	-470823.	0.000	467995.
MK	-352358.	0.000	571209.	-26281.	8.901	-470823.	0.000	731981.
SM	-88794096.	0.000	99739328.	-38207136.	2243.052	-118647312.	0.000	127856992.
AV	-352358.	0.000	395791.	-151616.	8.901	-470823.	0.000	507369.
YEARLY SUMMARY								
MN	-352358.	0.000	334559.	-346996.	8.901	-470823.	0.000	428701.
MK	0.	30.141	871725.	0.	8.901	0.	37.654	1117615.
SM	-575047488.	20725.934	1184428032.	-186474768.	26916.629	-768382592.	23339.652	1518630144.
AV	-190161.	6.854	391676.	-61665.	8.901	-254095.	7.718	502193.

S I T E E N E R G Y													
	2	3	4	5	6	7	8	9	10	11	12	13	14
MONTH	TOTAL HEAT LOAD	TOTAL COOLING LOAD	TOTAL ELECTR LOAD	RCVRED ENERGY	WASTED RCVRABL ENERGY	FUEL INPUT COOLING	BLEC INPUT COOLING	FUEL INPUT HEATING	BLEC INPUT HEATING	FUEL INPUT ELECT	TOTAL FUEL INPUT	TOTAL SITE ENERGY	TOTAL SOURCE ENERGY
JAN	343.0	0.0	306.7 89.8E	0.0	0.0	0.0	0.0 0.0E	512.0	26.6 7.8E	0.0	512.0	818.7	1433.1
FEB	290.3	0.0	276.4 80.9E	0.0	0.0	0.0	0.0 0.0E	431.9	22.6 6.6E	0.0	431.9	708.3	1261.9
MAR	192.6	0.0	308.3 90.3E	0.0	0.0	0.0	0.0 0.0E	296.7	19.1 5.6E	0.0	296.7	605.1	1222.7
APR	94.6	0.0	276.5 81.0E	0.0	0.0	0.0	0.0 0.0E	151.0	13.0 3.8E	0.0	151.0	427.5	981.2
MAY	0.0	0.0	344.3 100.8E	0.0	0.0	0.0	0.0 0.0E	0.0	0.0 0.0E	0.0	0.0	344.3	1033.8
JUN	0.0	0.0	376.1 110.2E	0.0	0.0	0.0	0.0 0.0E	0.0	0.0 0.0E	0.0	0.0	376.1	1129.5
JUL	0.0	0.0	371.2 108.7E	0.0	0.0	0.0	0.0 0.0E	0.0	0.0 0.0E	0.0	0.0	371.2	1114.8
AUG	0.0	0.0	413.7 121.2E	0.0	0.0	0.0	0.0 0.0E	0.0	0.0 0.0E	0.0	0.0	413.7	1242.3
SEP	0.0	0.0	359.2 105.2E	0.0	0.0	0.0	0.0 0.0E	0.0	0.0 0.0E	0.0	0.0	359.2	1078.6
OCT	74.7	0.0	345.0 101.0E	0.0	0.0	0.0	0.0 0.0E	119.1	8.9 2.6E	0.0	119.1	464.1	1155.1
NOV	126.3	0.0	271.8 79.6E	0.0	0.0	0.0	0.0 0.0E	198.7	15.1 4.4E	0.0	198.7	470.5	1014.9
DEC	273.3	0.0	301.4 88.3E	0.0	0.0	0.0	0.0 0.0E	420.4	24.6 7.2E	0.0	420.4	721.8	1325.4
-----	1394.9	0.0	3950.6 1157.0E	0.0	0.0	0.0	0.0 0.0E	2129.9	129.8 38.0E	0.0	2129.9	6080.4	13993.4

NOTE-- ALL ENTRIES ARE IN MBTU EXCEPT
 ENTRIES FOLLOWED BY E ARE IN MWH (THOUSANDS OF KWH)

ENTECH ENGINEERING
 READING, PA 19603
 REPORT- PS-B MONTHLY PEAK AND TOTAL ENERGY USE

EZDOE - ELITE SOFTWARE DEVELOPMENT INC
 FT. GEORGE G. MEADE

DOB-2.ID 6/7/1996 11:10:2 PDL RUN 1
 EMCS FEASIBILITY STUDY
 WEATHER FILE- BALTIMORE, MD

MO	UTILITY-	ELECTRICITY	FUEL-OIL
	TOTAL (MBTU)	306.740	511.971
JAN	PEAK (KBTU)	1060.265	2495.368
	DY/HR	31/17	31/7
	TOTAL (MBTU)	276.383	431.941
FEB	PEAK (KBTU)	1060.265	2615.656
	DY/HR	28/11	14/7
	TOTAL (MBTU)	308.347	296.710
MAR	PEAK (KBTU)	1060.265	2549.830
	DY/HR	29/7	7/7
	TOTAL (MBTU)	276.471	150.983
APR	PEAK (KBTU)	1060.265	2028.846
	DY/HR	27/7	4/7
	TOTAL (MBTU)	344.261	0.000
MAY	PEAK (KBTU)	1386.469	0.000
	DY/HR	20/16	31/1
	TOTAL (MBTU)	376.134	0.000
JUN	PEAK (KBTU)	1677.724	0.000
	DY/HR	29/16	30/1
	TOTAL (MBTU)	371.241	0.000
JUL	PEAK (KBTU)	1721.818	0.000
	DY/HR	25/14	31/1
	TOTAL (MBTU)	413.689	0.000
AUG	PEAK (KBTU)	1692.497	0.000
	DY/HR	18/16	31/1
	TOTAL (MBTU)	359.165	0.000
SEP	PEAK (KBTU)	1656.091	0.000
	DY/HR	1/16	30/1
	TOTAL (MBTU)	344.976	119.144
OCT	PEAK (KBTU)	1436.078	1812.805
	DY/HR	18/16	24/7
	TOTAL (MBTU)	271.777	198.747
NOV	PEAK (KBTU)	1060.265	2212.941
	DY/HR	30/8	25/7
	TOTAL (MBTU)	301.382	420.376
DEC	PEAK (KBTU)	1060.265	2440.693
	DY/HR	30/7	5/7
	ONE YEAR	3950.567	2129.872
	USE/PEAK	1721.818	2615.656

ENTECH ENGINEERING
READING, PA 19603
REPORT- PS-D PLANT LOADS SATISFIED

EZDOE - ELITE SOFTWARE DEVELOPMENT INC
FT. GEORGE G. MEADE

DOE-2.1D 6/ 7/1996 11:10: 2 PDL RUN 1
EMCS FEASIBILITY STUDY
WEATHER FILE- BALTIMORE, MD

HEATING LOADS	MBTU SUPPLIED	PCT OF TOTAL LOAD
-----	-----	-----
HW-BOILER	1394.9	100.0
	=====	=====
LOAD SATISFIED	1394.9	100.0
TOTAL LOAD ON PLANT	1394.9	
ELECTRICAL LOADS	MBTU SUPPLIED	PCT OF TOTAL LOAD
-----	-----	-----
ELECTRICITY	3950.6	100.0
	=====	=====
LOAD SATISFIED	3950.6	100.0
TOTAL LOAD ON PLANT	3950.7	

ENTRCH ENGINEERING
READING, PA 19603
REPORT- PS-D PLANT LOADS SATISFIED

EZDOE - ELITE SOFTWARE DEVELOPMENT INC
FT. GEORGE G. MEADE

DOE-2.1D 6/ 7/1996 11:10: 2 PDL RUN 1
EMCS FEASIBILITY STUDY
WEATHER FILE- BALTIMORE, MD
----- (CONTINUED) -----

SUMMARY OF LOADS MET

TYPE OF LOAD	TOTAL LOAD (MBTU)	LOAD SATISFIED (MBTU)	TOTAL OVERLOAD (MBTU)	PEAK OVERLOAD (MBTU)	HOURS OVERLOADED
HEATING LOADS	1394.9	1394.9	0.000	0.000	0
ELECTRICAL LOADS	3950.7	3950.6	0.000	0.000	0

ENTECH ENGINEERING
READING, PA 19603
REPORT- PS-H EQUIPMENT USE STATISTICS

EZDOE - ELITE SOFTWARE DEVELOPMENT INC
FT. GEORGE G. MEADE

DOE-2.1D 6/ 7/1996 11:10: 2 PDL RUN 1
EMCS FEASIBILITY STUDY
WEATHER FILE- BALTIMORE, MD

EQUIPMENT	AVG	MAX	MON		SIZE OPER		SIZE OPER		SIZE OPER		SIZE OPER	
	OPER RATIO	LOAD (MBTU)	DAY	HR	(MBTU)	HRS	(MBTU)	HRS	(MBTU)	HRS	(MBTU)	HRS
HW-BOILER	0.123	2.038	2	14	7	2.400	4728					

ENTECH ENGINEERING
READING, PA 19603
REPORT- PS-I EQUIPMENT LIFE CYCLE COSTS

EZDOE - ELITE SOFTWARE DEVELOPMENT INC
FT. GEORGE G. MEADE

DOB-2.1D 6/ 7/1996 11:10: 2 PDL RUN 1
EMCS FEASIBILITY STUDY
WEATHER FILE- BALTIMORE, MD

E Q U I P M E N T T O T A L S

HW-BOILER	137.0		
NOMINAL SIZE (MBTU)		2.400	
NUMBER INSTALLED		2	
FIRST COST (K\$)	127.5	127.5	
ANNUAL COST (K\$)	4.1	4.1	
CYCLICAL COST (K\$)	5.3	5.3	
-----TOTAL----- (K\$)		137.0	

EQUIPMENT TOTAL	137.0		

ENERGY TYPE IN SITE MBTU -	ELECTRICITY	FUEL-OIL
CATEGORY OF USE		
SPACE HEAT	94.29	2129.82
SPACE COOL	507.60	0.00
HVAC AUX	779.43	0.00
DOM HOT WTR	0.00	0.00
AUX SOLAR	0.00	0.00
LIGHTS	1701.29	0.00
VERT TRANS	0.00	0.00
MISC EQUIP	867.86	0.00
TOTAL	3950.47	2129.82

TOTAL SITE ENERGY 6080.44 MBTU 67.9 KBTU/SQFT-YR GROSS-AREA 67.9 KBTU/SQFT-YR NET-AREA
 TOTAL SOURCE ENERGY 13993.44 MBTU 156.3 KBTU/SQFT-YR GROSS-AREA 156.3 KBTU/SQFT-YR NET-AREA

PERCENT OF HOURS ANY SYSTEM ZONE OUTSIDE OF THROTTLING RANGE = 34.4
 PERCENT OF HOURS ANY PLANT LOAD NOT SATISFIED = 0.0

NOTE ELECTRICITY AND/OR FUEL USED TO GENERATE ELECTRICITY IS APPORTIONED BASED
 ON THE YEARLY DEMAND. ALL OTHER ENERGY TYPES ARE APPORTIONED HOURLY.

MMDDHH	HW-BOILE R LOAD BTU/HR	HW-BOILE R ELECTRIC USE BTU/HR	HW-BOILE R FUEL USE BTU/HR
	---- (1)	---- (3)	---- (4)
MONTHLY SUMMARY (JAN)			
MN	13490.	1187.	22044.
MX	1927099.	52800.	2495368.
SM	343015584.	20986612.	511970144.
AV	461042.	28208.	688132.
MONTHLY SUMMARY (FEB)			
MN	13490.	1187.	22044.
MX	2038266.	52800.	2615656.
SM	290333184.	17508198.	431940096.
AV	432043.	26054.	642768.
MONTHLY SUMMARY (MAR)			
MN	13490.	1187.	22044.
MX	1977314.	52800.	2549830.
SM	192596784.	13493908.	296709056.
AV	258867.	18137.	398803.
MONTHLY SUMMARY (APR)			
MN	13490.	1187.	22044.
MX	1504567.	52800.	2028846.
SM	94649472.	7617783.	150982544.
AV	131458.	10580.	209698.
MONTHLY SUMMARY (OCT)			
MN	13490.	1187.	22044.
MX	1313293.	52800.	1812805.
SM	74687832.	6005059.	119143808.
AV	194500.	15638.	310270.
MONTHLY SUMMARY (NOV)			
MN	13490.	1187.	22044.
MX	1669713.	52800.	2212941.
SM	126301088.	9648857.	198746080.
AV	175418.	13401.	276036.
MONTHLY SUMMARY (DEC)			
MN	13490.	1187.	22044.
MX	1876880.	52800.	2440693.
SM	273343424.	19030296.	420375104.
AV	367397.	25578.	565020.

HW-BOILE HW-BOILE HW-BOILE
R R R
LOAD ELECTRIC FUEL
USE USE USE
BTU/HR BTU/HR BTU/HR
----(1) ----(3) ----(4)

YEARLY SUMMARY

MN	13490.	1187.	22044.
MX	2038266.	52800.	2615656.
SM	1394927360.	94290712.	2129866752.
AV	295035.	19943.	450479.

FT. MEADE, MARYLAND

Building: 4554

Square feet 95,730

Exterior Wall	
Components	R-Value
Outside Surface	0.17
Brick	0.44
Air Space	1.10
Concrete Block	1.72
Plaster	0.56
Inside Surface	0.68
Total R-Value	4.67
Total U-Value	0.21

Exterior Roof	
Components	R-Value
Outside Surface	0.17
Slate	0.33
Wood Deck	0.93
2" Insulation	12.00
Plaster Cig	0.56
Inside Surface	0.61
Total R-Value	14.60
Total U-Value	0.07

Calculated Total Area	
No. of Floors	4
Avg. Floor to Floor Height	12
No. of Basement Levels	1
Gross Floor Area	95730
Roof Area	19140
Estimated Infiltration (cfm)	9600
Gross Wall Area	52900
Door Area	200
Gross Window Area	1350
Other	
Net Wall Area	51350

Window and Door	
	U-Value
Window Single Pane W/Storm	0.60
Window Single Pane Wo/Storm	
Window Double Pane	
Skylight	
Glass Block	
Other	
Door Type 1	0.50
Door Type 2	
Door Type 3	

FT. MEADE, MARYLAND EQUIPMENT SCHEDULE

BUILDING NO. 4554

Page 1 of 2

EQUIPMENT	SYSTEM NUMBER							
	1	2	3	4	5	6	7	8
Equipment Name	AC-13	AC-14	AC-15	AC-16	AC-20	AC-22	AC-17	AC-18
COOLING:								
Type of Cooling	1	1	1	1	1	1	1	1
Air Side	2	2	2	2	2	2	2	2
Location in Building	BSMT A&B	1st Flr A&B	2nd Flr A&B	3rd Flr A&B	4th Flr A&B	BSMT C&D	1st Flr C&D	2nd Flr C&D
Area Sq. Feet	14400	9600	9600	9600	5000	4800	6400	9600
Supply CFM	11930	15680	15695	16870	6000	2400	10765	15265
Supply Fan HP	5	15	15	20	3	1 1/2	10	15
O.A. CFM or %	20%	20%	20%	20%	20%	20%	20%	20%
Return CFM								
Return Fan HP								
Chiller Tonnage	15	30	40	40	20	5	30	40
Tower or Condenser Fan HP	2/3	3	5	5	3	1/2	3	5
Condenser Pump HP								
Chilled Water Pump HP								
HEATING:								
Type of Heating								
Source								
MBTUH								
Hot Water Pump HP								
Condensate Pump HP								
ADDITIONAL:								
Aux. HP Cooling								
Aux. HP Heating								
Operating Schedule Hrs./Week								
Type of Cooling	Type of Heating							
(1) Air Cooled DX	(1) Boiler Hot Water							
(2) Water Cooled DX	(2) Boiler Steam							
(3) Air Cooled Chiller	(3) Steam to Hot Water Converter							
	Heating Source							
(1) Single Zone	(1) Natural Gas							
(2) Multi-Zone	(2) Central Plant Steam							
(3) VAV	(3) Central Plant Hot Water							
	(4) Oil							
	(5) Electric							

**FT. MEADE, MARYLAND
EQUIPMENT SCHEDULE**

BUILDING NO. 4554

Page 2 of 2

EQUIPMENT	SYSTEM NUMBER							
	1	2	3	4	5	6	7	8
Equipment Name	AC-19	AC-21	AC-24	BOILER	BOILER			
COOLING:								
Type of Cooling	1	1	1					
Air Side	2	2	1					
Location in Building	3rd Flr C&D	4th Flr C&D	2nd Flr D wing					
Area Sq. Feet	9600	5000	3200					
Supply CFM	16785	6000	3500					
Supply Fan HP	20	3	2					
O.A. CFM or %	20%	20%	20%					
Return CFM								
Return Fan HP								
Chiller Tonnage	40	20	10					
Tower or Condenser Fan HP	5	3	2/3					
Condenser Pump HP								
Chilled Water Pump HP								
HEATING:								
Type of Heating				1	1			
Source				1	1			
MBTUH				2520/1640	2520/1640			
Hot Water Pump HP				4	4			
Condensate Pump HP								
ADDITIONAL:								
Aux. HP Cooling								
Aux. HP Heating								
Operating Schedule Hrs./Week								
Type of Cooling								
(1) Air Cooled DX								
(2) Water Cooled DX								
(3) Air Cooled Chiller								
Air Side								
(4) VAV w/ Reheat								
(5) Constant Volume Reheat								
(6) Heating and Ventilating								
Type of Heating								
(1) Boiler Hot Water								
(2) Boiler Steam								
(3) Steam to Hot Water Converter								
Heating Source								
(1) Natural Gas								
(2) Central Plant Steam								
(3) Central Plant Hot Water								
(4) Oil								
(5) Electric								

EMCS Annual Energy Savings Summary Report

```

=====
Base: FTMEADE
Building: 4554
Case: 1
Description:
=====

```

```

=====
Fuel Type: Natural gas (methane)
Heating Value: 1,031 Btu/cf
=====

```

Caution

```

=====
The ESA program makes no attempt to exclude incompatible strategies.
It is the user's responsibility to select all appropriate strategies.
=====

```

Annual Energy Savings Table for Multi-zone DX-A/C

```

=====
Description: MULTI-ZONE UNITS (10)
=====

```

Strategy	MBtu/yr	kWh/yr	kW	mh/yr
Demand Limiting	0.000	0	16.0	0
Hot/Cold Deck Reset	731.820	37,633	0.0	0
Subtotals	731.820	37,633	16.0	0
Heating Value /	1,031 Btu/cf			
Totals	709,816 cf /yr	37,633 kWh/yr	16.0 kW	0 mh/yr

Annual Energy Savings Table for Hot Water Boiler

```

=====
Description: BOILER
=====

```

Strategy	MBtu/yr	kWh/yr	kW	mh/yr
Hot Water OA Reset	465.231	0	0.0	0
Subtotals	465.231	0	0.0	0
Heating Value /	1,031 Btu/cf			
Totals	451,242 cf /yr	0 kWh/yr	0.0 kW	0 mh/yr

Annual Energy Savings Table for Lighting Control

Description: LIGHTING				
Strategy	MBtu/yr	kWh/yr	kW	mh/yr
Lighting Control	0.000	129,792	0.0	0
Totals	0.000	129,792	0.0	0
	MBtu/yr	kWh/yr	kW	mh/yr

EMCS Annual Energy Savings for Building 4554

Description	Value	Units
Natural gas (methane)	1,161,058	cf /yr
Electrical Energy	167,425	kWh/yr
Electrical Demand Reduction	16.0	kW
Labor Savings	0	mh/yr

**UMCS FEASIBILITY STUDY
FORT MEADE
BUILDING 4554 - ADMINISTRATIVE
DOE ENERGY SAVINGS SUMMARY**

	Space Heat		Space Cool		HVAC Aux		Lights		Misc Equip		TOTAL		TOTAL	
	Electricity mmBtu	Natural Gas mmBtu	Electricity mmBtu	Natural Gas mmBtu	Electricity mmBtu	Natural Gas mmBtu	Electricity mmBtu	Natural Gas mmBtu	Electricity mmBtu	Natural Gas mmBtu	Electricity mmBtu	Natural Gas mmBtu	Electricity Kwh	Natural Gas MCF
Existing	249.0	8,494.4	1,115.6	2,494.0	2,005.3	1,002.6	6,866.6	8,494.4	2,011,884	2,011,884	8,239.0			
New w/Night Setback	115.1	3,164.6	631.0	932.3	2,005.3	1,002.6	4,686.3	3,164.6	1,373,082	3,069.4				
Night Setback Savings							2,180.2	5,329.8	638,802	5,169.6				
New w/Night Setback and Vent/Recirc	109.0	2,902.7	642.6	901.3	2,005.3	1,002.6	4,660.8	2,902.7	1,365,602	2,815.5				
Vent/Recirc Savings							25.5	261.9	7,480	254.0				
New w/Night Setback & Vent/Recirc & Economizer	104.0	2,433.8	572.5	894.6	2,005.3	1,002.6	4,578.9	2,433.8	1,341,617	2,360.6				
Economizer Savings							81.9	468.9	23,985	454.8				

MMDDHH	AC-13	AC-13	AC-13	AC-13	AC-13	AC-14	AC-14	AC-14
	TOT HTG COIL PWR BTU/HR	SUPPLY ELECTRIC KW	HEATING CAPACITY BTU/HR	COOLING ELECTRIC KW	COOLING CAPACITY BTU/HR	TOT HTG COIL PWR BTU/HR	SUPPLY ELECTRIC KW	HEATING CAPACITY BTU/HR
	---- (5)	---- (49)	---- (78)	---- (47)	---- (70)	---- (5)	---- (49)	---- (78)
MONTHLY SUMMARY (JAN)								
MN	-149671.	3.781	-200008.	0.000	195857.	-333463.	8.777	-464253.
MX	-10755.	3.781	-200008.	0.000	199644.	-31398.	8.777	-464253.
SM	-66026048.	2813.212	-148806272.	0.000	145723952.	-135540720.	6529.936	-345404384.
AV	-88745.	3.781	-200008.	0.000	195866.	-182178.	8.777	-464253.
MONTHLY SUMMARY (FEB)								
MN	-159390.	3.781	-200008.	0.000	195857.	-340131.	8.777	-464253.
MX	-12315.	3.781	-200008.	0.000	205766.	-14.	8.777	-464253.
SM	-63339708.	2540.966	-134405648.	0.000	131719976.	-113431984.	5898.007	-311978144.
AV	-94256.	3.781	-200008.	0.000	196012.	-168798.	8.777	-464253.
MONTHLY SUMMARY (MAR)								
MN	-138160.	3.781	-200008.	0.000	191969.	-268617.	8.777	-464253.
MX	-753.	3.781	-200008.	0.000	212775.	-9.	8.777	-464253.
SM	-61209760.	2813.212	-148806272.	0.000	145870256.	-83332824.	6529.936	-345404384.
AV	-82271.	3.781	-200008.	0.000	196062.	-112006.	8.777	-464253.
MONTHLY SUMMARY (APR)								
MN	-124042.	3.781	-200008.	0.000	188556.	-226171.	8.777	-464253.
MX	-10.	3.781	-200008.	0.000	216935.	-4.	8.777	-464253.
SM	-49574688.	2722.463	-144006064.	0.000	141715328.	-46054080.	6319.293	-334262304.
AV	-68854.	3.781	-200008.	0.000	196827.	-63964.	8.777	-464253.
MONTHLY SUMMARY (MAY)								
MN	0.	3.781	0.	0.000	179768.	0.	8.777	0.
MX	0.	3.781	0.	2.415	230297.	0.	8.777	0.
SM	0.	2813.212	0.	17.618	147983856.	0.	6529.936	0.
AV	0.	3.781	0.	0.024	198903.	0.	8.777	0.
MONTHLY SUMMARY (JUN)								
MN	0.	3.781	0.	0.000	179768.	0.	8.777	0.
MX	0.	3.781	0.	12.182	232362.	0.	8.777	0.
SM	0.	2722.463	0.	1003.464	148619760.	0.	6319.293	0.
AV	0.	3.781	0.	1.394	206416.	0.	8.777	0.
MONTHLY SUMMARY (JUL)								
MN	0.	3.781	0.	0.000	183344.	0.	8.777	0.
MX	0.	3.781	0.	14.985	244333.	0.	8.777	0.
SM	0.	2813.212	0.	2343.014	158155200.	0.	6529.936	0.
AV	0.	3.781	0.	3.149	212574.	0.	8.777	0.

	AC-13	AC-13	AC-13	AC-13	AC-13	AC-14	AC-14	AC-14
	TOT HTG COIL PWR BTU/HR	SUPPLY ELECTRIC KW	HEATING CAPACITY BTU/HR	COOLING ELECTRIC KW	COOLING CAPACITY BTU/HR	TOT HTG COIL PWR BTU/HR	SUPPLY ELECTRIC KW	HEATING CAPACITY BTU/HR
	----(5)	----(49)	----(78)	----(47)	----(70)	----(5)	----(49)	----(78)
MONTHLY SUMMARY (AUG)								
MN	0.	3.781	0.	0.000	187700.	0.	8.777	0.
MX	0.	3.781	0.	16.113	234822.	0.	8.777	0.
SM	0.	2813.212	0.	3418.675	155782544.	0.	6529.936	0.
AV	0.	3.781	0.	4.595	209385.	0.	8.777	0.
MONTHLY SUMMARY (SEP)								
MN	0.	3.781	0.	0.000	187134.	0.	8.777	0.
MX	0.	3.781	0.	15.093	235675.	0.	8.777	0.
SM	0.	2722.463	0.	2091.929	146788160.	0.	6319.293	0.
AV	0.	3.781	0.	2.905	203872.	0.	8.777	0.
MONTHLY SUMMARY (OCT)								
MN	-125506.	3.781	-200008.	0.000	185317.	-302027.	8.777	-464253.
MX	0.	3.781	0.	10.064	214783.	0.	8.777	0.
SM	-21612522.	2813.212	-76803240.	2159.956	147222848.	-55925476.	6529.936	-178273184.
AV	-29049.	3.781	-103230.	2.903	197880.	-75169.	8.777	-239615.
MONTHLY SUMMARY (NOV)								
MN	-79371.	3.781	-200008.	0.000	195857.	-200428.	8.777	-464253.
MX	-7.	3.781	-200008.	0.000	242866.	-1.	8.777	-464253.
SM	-27002596.	2722.463	-144006064.	0.000	143048032.	-70353024.	6319.293	-334262304.
AV	-37504.	3.781	-200008.	0.000	198678.	-97713.	8.777	-464253.
MONTHLY SUMMARY (DEC)								
MN	-119318.	3.781	-200008.	0.000	195857.	-287156.	8.777	-464253.
MX	-15.	3.781	-200008.	0.000	209097.	-7673.	8.777	-464253.
SM	-49382872.	2813.212	-148806272.	0.000	145869696.	-119452512.	6529.936	-345404384.
AV	-66375.	3.781	-200008.	0.000	196061.	-160554.	8.777	-464253.
YEARLY SUMMARY								
MN	-159390.	3.781	-200008.	0.000	179768.	-340131.	8.777	-464253.
MX	0.	3.781	0.	16.113	244333.	0.	8.777	0.
SM	-338148224.	33123.305	-945639872.	11034.655	1758499584.	-624090624.	76884.734	-2194989056.
AV	-38601.	3.781	-107950.	1.260	200742.	-71243.	8.777	-250570.

MMDDHH	AC-14	AC-14	AC-15	AC-15	AC-15	AC-15	AC-15	AC-15
	COOLING ELECTRIC KW	COOLING CAPACITY BTU/HR	TOT HTG COIL PWR BTU/HR	SUPPLY ELECTRIC KW	HEATING CAPACITY BTU/HR	COOLING ELECTRIC KW	COOLING CAPACITY BTU/HR	TOT HTG COIL PWR BTU/HR
	---- (47)	---- (70)	---- (5)	---- (49)	---- (78)	---- (47)	---- (70)	---- (5)
MONTHLY SUMMARY (JAN)								
MN	0.000	467084.	-333463.	8.777	-464253.	0.000	467084.	-333463.
MX	0.000	478256.	-31398.	8.777	-464253.	0.000	478256.	-31398.
SM	0.000	347534560.	-135540720.	6529.936	-345404384.	0.000	347534560.	-135540720.
AV	0.000	467116.	-182178.	8.777	-464253.	0.000	467116.	-182178.
MONTHLY SUMMARY (FEB)								
MN	0.000	467084.	-340131.	8.777	-464253.	0.000	467084.	-340131.
MX	0.000	486873.	-14.	8.777	-464253.	0.000	486873.	-14.
SM	0.000	314050016.	-113431984.	5898.007	-311978144.	0.000	314050016.	-113431984.
AV	0.000	467336.	-168798.	8.777	-464253.	0.000	467336.	-168798.
MONTHLY SUMMARY (MAR)								
MN	0.000	457002.	-268617.	8.777	-464253.	0.000	457002.	-268617.
MX	0.000	509682.	-9.	8.777	-464253.	0.000	509682.	-9.
SM	0.000	347828928.	-83332824.	6529.936	-345404384.	0.000	347828928.	-83332824.
AV	0.000	467512.	-112006.	8.777	-464253.	0.000	467512.	-112006.
MONTHLY SUMMARY (APR)								
MN	0.000	460116.	-226171.	8.777	-464253.	0.000	460116.	-226171.
MX	0.000	529120.	-4.	8.777	-464253.	0.000	529120.	-4.
SM	0.000	338396896.	-46054080.	6319.293	-334262304.	0.000	338396896.	-46054080.
AV	0.000	469996.	-63964.	8.777	-464253.	0.000	469996.	-63964.
MONTHLY SUMMARY (MAY)								
MN	0.000	428714.	0.	8.777	0.	0.000	428714.	0.
MX	18.558	525416.	0.	8.777	0.	18.558	525416.	0.
SM	1992.469	352724352.	0.	6529.936	0.	1992.469	352724352.	0.
AV	2.678	474092.	0.	8.777	0.	2.678	474092.	0.
MONTHLY SUMMARY (JUN)								
MN	0.000	430896.	0.	8.777	0.	0.000	430896.	0.
MX	36.812	527326.	0.	8.777	0.	36.812	527326.	0.
SM	7109.560	349182688.	0.	6319.293	0.	7109.560	349182688.	0.
AV	9.874	484976.	0.	8.777	0.	9.874	484976.	0.
MONTHLY SUMMARY (JUL)								
MN	0.000	435288.	0.	8.777	0.	0.000	435288.	0.
MX	39.720	539261.	0.	8.777	0.	39.720	539261.	0.
SM	10013.230	368718624.	0.	6529.936	0.	10013.230	368718624.	0.
AV	13.459	495590.	0.	8.777	0.	13.459	495590.	0.

	AC-14	AC-14	AC-15	AC-15	AC-15	AC-15	AC-15	AC-16
	COOLING ELECTRIC KW	COOLING CAPACITY BTU/HR	TOT HTG COIL PWR BTU/HR	SUPPLY ELECTRIC KW	HEATING CAPACITY BTU/HR	COOLING ELECTRIC KW	COOLING CAPACITY BTU/HR	TOT HTG COIL PWR BTU/HR
	---- (47)	---- (70)	---- (5)	---- (49)	---- (78)	---- (47)	---- (70)	---- (5)
MONTHLY SUMMARY (AUG)								
MN	0.000	446684.	0.	8.777	0.	0.000	446684.	0.
MK	36.815	532445.	0.	8.777	0.	36.815	532445.	0.
SM	9282.993	368443616.	0.	6529.936	0.	9282.993	368443616.	0.
AV	12.477	495220.	0.	8.777	0.	12.477	495220.	0.
MONTHLY SUMMARY (SEP)								
MN	0.000	447122.	0.	8.777	0.	0.000	447122.	0.
MK	32.295	537030.	0.	8.777	0.	32.295	537030.	0.
SM	5107.629	347696672.	0.	6319.293	0.	5107.629	347696672.	0.
AV	7.094	482912.	0.	8.777	0.	7.094	482912.	0.
MONTHLY SUMMARY (OCT)								
MN	0.000	441947.	-302027.	8.777	-464253.	0.000	441947.	-302027.
MK	18.610	512421.	0.	8.777	0.	18.610	512421.	0.
SM	4385.479	350915776.	-55925476.	6529.936	-178273184.	4385.479	350915776.	-55925476.
AV	5.894	471661.	-75169.	8.777	-239615.	5.894	471661.	-75169.
MONTHLY SUMMARY (NOV)								
MN	0.000	467084.	-200428.	8.777	-464253.	0.000	467084.	-200428.
MK	0.000	577283.	-1.	8.777	-464253.	0.000	577283.	-1.
SM	0.000	341444640.	-70353024.	6319.293	-334262304.	0.000	341444640.	-70353024.
AV	0.000	474229.	-97713.	8.777	-464253.	0.000	474229.	-97713.
MONTHLY SUMMARY (DEC)								
MN	0.000	467084.	-287156.	8.777	-464253.	0.000	467084.	-287156.
MK	0.000	491186.	-7673.	8.777	-464253.	0.000	491186.	-7673.
SM	0.000	347814592.	-119452512.	6529.936	-345404384.	0.000	347814592.	-119452512.
AV	0.000	467493.	-160554.	8.777	-464253.	0.000	467493.	-160554.
YEARLY SUMMARY								
MN	0.000	428714.	-340131.	8.777	-464253.	0.000	428714.	-340131.
MK	39.720	577283.	0.	8.777	0.	39.720	577283.	0.
SM	37891.359	4174751488.	-624090624.	76884.734	-2194989056.	37891.359	4174751488.	-624090624.
AV	4.325	476570.	-71243.	8.777	-250570.	4.325	476570.	-71243.

MMDDHH	AC-16	AC-16	AC-16	AC-16	AC-20	AC-20	AC-20	AC-20
	SUPPLY ELECTRIC KW	HEATING CAPACITY BTU/HR	COOLING ELECTRIC KW	COOLING CAPACITY BTU/HR	TOT HTG COIL PWR BTU/HR	SUPPLY ELECTRIC KW	HEATING CAPACITY BTU/HR	COOLING ELECTRIC KW
	----(49)	----(78)	----(47)	----(70)	----(5)	----(49)	----(78)	----(47)
MONTHLY SUMMARY (JAN)								
MN	8.777	-464253.	0.000	467084.	-324726.	7.894	-417536.	0.000
MX	8.777	-464253.	0.000	478256.	-65017.	7.894	-417536.	0.000
SM	6529.936	-345404384.	0.000	347534560.	-140870656.	5872.839	-310646752.	0.000
AV	8.777	-464253.	0.000	467116.	-189342.	7.894	-417536.	0.000
MONTHLY SUMMARY (FEB)								
MN	8.777	-464253.	0.000	467084.	-318257.	7.894	-417536.	0.000
MX	8.777	-464253.	0.000	486873.	-5043.	7.894	-417536.	0.000
SM	5898.007	-311978144.	0.000	314050016.	-116532440.	5304.500	-280584160.	0.000
AV	8.777	-464253.	0.000	467336.	-173411.	7.894	-417536.	0.000
MONTHLY SUMMARY (MAR)								
MN	8.777	-464253.	0.000	457002.	-250954.	7.894	-417536.	0.000
MX	8.777	-464253.	0.000	509682.	-10.	7.894	-417536.	0.000
SM	6529.936	-345404384.	0.000	347828928.	-90367888.	5872.839	-310646752.	0.000
AV	8.777	-464253.	0.000	467512.	-121462.	7.894	-417536.	0.000
MONTHLY SUMMARY (APR)								
MN	8.777	-464253.	0.000	460116.	-218166.	7.894	-417536.	0.000
MX	8.777	-464253.	0.000	529120.	-4.	7.894	-417536.	0.000
SM	6319.293	-334262304.	0.000	338396896.	-53367372.	5683.393	-300625888.	0.000
AV	8.777	-464253.	0.000	469996.	-74121.	7.894	-417536.	0.000
MONTHLY SUMMARY (MAY)								
MN	8.777	0.	0.000	428714.	0.	7.894	0.	0.000
MX	8.777	0.	18.558	525416.	0.	7.894	0.	14.209
SM	6529.936	0.	1992.469	352724352.	0.	5872.839	0.	1425.114
AV	8.777	0.	2.678	474092.	0.	7.894	0.	1.915
MONTHLY SUMMARY (JUN)								
MN	8.777	0.	0.000	430896.	0.	7.894	0.	0.000
MX	8.777	0.	36.812	527326.	0.	7.894	0.	30.273
SM	6319.293	0.	7109.560	349182688.	0.	5683.393	0.	5680.793
AV	8.777	0.	9.874	484976.	0.	7.894	0.	7.890
MONTHLY SUMMARY (JUL)								
MN	8.777	0.	0.000	435288.	0.	7.894	0.	0.000
MX	8.777	0.	39.720	539261.	0.	7.894	0.	32.744
SM	6529.936	0.	10013.230	368718624.	0.	5872.839	0.	8284.690
AV	8.777	0.	13.459	495590.	0.	7.894	0.	11.135

	AC-16	AC-16	AC-16	AC-16	AC-20	AC-20	AC-20	AC-20
	SUPPLY ELECTRIC KW	HEATING CAPACITY BTU/HR	COOLING ELECTRIC KW	COOLING CAPACITY BTU/HR	TOT HTG COIL PWR BTU/HR	SUPPLY ELECTRIC KW	HEATING CAPACITY BTU/HR	COOLING ELECTRIC KW
	----(49)	----(78)	----(47)	----(70)	----(5)	----(49)	----(78)	----(47)
MONTHLY SUMMARY (AUG)								
MN	8.777	0.	0.000	446684.	0.	7.894	0.	0.000
MX	8.777	0.	36.815	532445.	0.	7.894	0.	29.905
SM	6529.936	0.	9282.993	368443616.	0.	5872.839	0.	7418.938
AV	8.777	0.	12.477	495220.	0.	7.894	0.	9.972
MONTHLY SUMMARY (SEP)								
MN	8.777	0.	0.000	447122.	0.	7.894	0.	0.000
MX	8.777	0.	32.295	537030.	0.	7.894	0.	26.002
SM	6319.293	0.	5107.629	347696672.	0.	5683.393	0.	3873.074
AV	8.777	0.	7.094	482912.	0.	7.894	0.	5.379
MONTHLY SUMMARY (OCT)								
MN	8.777	-464253.	0.000	441947.	-261216.	7.894	-417536.	0.000
MX	8.777	0.	18.610	512421.	0.	7.894	0.	14.948
SM	6529.936	-178273184.	4385.479	350915776.	-54009036.	5872.839	-160333792.	3465.947
AV	8.777	-239615.	5.894	471661.	-72593.	7.894	-215502.	4.659
MONTHLY SUMMARY (NOV)								
MN	8.777	-464253.	0.000	467084.	-203852.	7.894	-417536.	0.000
MX	8.777	-464253.	0.000	577283.	-2.	7.894	-417536.	0.000
SM	6319.293	-334262304.	0.000	341444640.	-78156776.	5683.393	-300625888.	0.000
AV	8.777	-464253.	0.000	474229.	-108551.	7.894	-417536.	0.000
MONTHLY SUMMARY (DEC)								
MN	8.777	-464253.	0.000	467084.	-278549.	7.894	-417536.	0.000
MX	8.777	-464253.	0.000	491186.	-32261.	7.894	-417536.	0.000
SM	6529.936	-345404384.	0.000	347814592.	-125707032.	5872.839	-310646752.	0.000
AV	8.777	-464253.	0.000	467493.	-168961.	7.894	-417536.	0.000
YEARLY SUMMARY								
MN	8.777	-464253.	0.000	428714.	-324726.	7.894	-417536.	0.000
MX	8.777	0.	39.720	577283.	0.	7.894	0.	32.744
SM	76884.734	-2194989056.	37891.359	4174751488.	-659011200.	69147.945	-1974110080.	30148.557
AV	8.777	-250570.	4.325	476570.	-75230.	7.894	-225355.	3.442

MMDDHH	AC-20	AC-22	AC-22	AC-22	AC-22	AC-22	AC-17	AC-17
	COOLING CAPACITY BTU/HR	TOT HTG COIL PWR BTU/HR	SUPPLY ELECTRIC KW	HEATING CAPACITY BTU/HR	COOLING ELECTRIC KW	COOLING CAPACITY BTU/HR	TOT HTG COIL PWR BTU/HR	SUPPLY ELECTRIC KW
	----(70)	----(5)	----(49)	----(78)	----(47)	----(70)	----(5)	----(49)
MONTHLY SUMMARY (JAN)								
MN	409142.	-258781.	7.901	-417901.	0.000	419476.	-333128.	8.825
MX	418914.	-29972.	7.901	-417901.	0.000	428907.	-27221.	8.825
SM	304423104.	-116471088.	5877.970	-310918240.	0.000	312108992.	-134555616.	6565.874
AV	409171.	-156547.	7.900	-417901.	0.000	419501.	-180854.	8.825
MONTHLY SUMMARY (FEB)								
MN	409142.	-308752.	7.901	-417901.	0.000	419476.	-341310.	8.825
MX	422707.	-22218.	7.901	-417901.	0.000	430849.	-14.	8.825
SM	275058240.	-108263168.	5309.135	-280829344.	0.000	281971424.	-112733568.	5930.467
AV	409313.	-161106.	7.900	-417901.	0.000	419600.	-167758.	8.825
MONTHLY SUMMARY (MAR)								
MN	399011.	-240086.	7.901	-417901.	0.000	409089.	-268816.	8.825
MX	446342.	-12.	7.901	-417901.	0.000	456729.	-9.	8.825
SM	304645408.	-98206184.	5877.970	-310918240.	0.000	312306240.	-82664224.	6565.874
AV	409470.	-131998.	7.900	-417901.	0.000	419766.	-111108.	8.825
MONTHLY SUMMARY (APR)								
MN	403039.	-205694.	7.901	-417901.	0.000	406161.	-226514.	8.825
MX	459356.	-9.	7.901	-417901.	0.000	458889.	-3.	8.825
SM	296232896.	-71166072.	5688.358	-300888608.	0.000	303270240.	-45800404.	6354.072
AV	411435.	-98842.	7.900	-417901.	0.000	421209.	-63612.	8.825
MONTHLY SUMMARY (MAY)								
MN	375532.	0.	7.901	0.	0.000	385017.	0.	8.825
MX	462441.	0.	7.901	0.	8.139	484629.	0.	8.825
SM	309056448.	0.	5877.970	0.	163.840	316546144.	0.	6565.874
AV	415398.	0.	7.900	0.	0.220	425465.	0.	8.825
MONTHLY SUMMARY (JUN)								
MN	377501.	0.	7.901	0.	0.000	384643.	0.	8.825
MX	464002.	0.	7.901	0.	22.516	497685.	0.	8.825
SM	306273088.	0.	5688.358	0.	2297.210	317716672.	0.	6354.072
AV	425379.	0.	7.900	0.	3.191	441273.	0.	8.825
MONTHLY SUMMARY (JUL)								
MN	381291.	0.	7.901	0.	0.000	390921.	0.	8.825
MX	473078.	0.	7.901	0.	25.973	510681.	0.	8.825
SM	323401184.	0.	5877.970	0.	4726.064	337987968.	0.	6565.874
AV	434679.	0.	7.900	0.	6.352	454285.	0.	8.825

	AC-20	AC-22	AC-22	AC-22	AC-22	AC-22	AC-17	AC-17
	COOLING CAPACITY BTU/HR	TOT HTG COIL PWR BTU/HR	SUPPLY ELECTRIC KW	HEATING CAPACITY BTU/HR	COOLING ELECTRIC KW	COOLING CAPACITY BTU/HR	TOT HTG COIL PWR BTU/HR	SUPPLY ELECTRIC KW
	----(70)	----(5)	----(49)	----(78)	----(47)	----(70)	----(5)	----(49)
MONTHLY SUMMARY (AUG)								
MN	390771.	0.	7.901	0.	0.000	400225.	0.	8.825
MX	466234.	0.	7.901	0.	26.763	494834.	0.	8.825
SM	323418176.	0.	5877.970	0.	5634.488	334871712.	0.	6565.874
AV	434702.	0.	7.900	0.	7.573	450096.	0.	8.825
MONTHLY SUMMARY (SEP)								
MN	392852.	0.	7.901	0.	0.000	404551.	0.	8.825
MX	471229.	0.	7.901	0.	22.521	495856.	0.	8.825
SM	304823520.	0.	5688.358	0.	3221.274	314037888.	0.	6354.072
AV	423366.	0.	7.900	0.	4.474	436164.	0.	8.825
MONTHLY SUMMARY (OCT)								
MN	387124.	-248788.	7.901	-417901.	0.000	396901.	-302681.	8.825
MX	446838.	0.	7.901	0.	16.304	459515.	0.	8.825
SM	307143264.	-48247920.	5877.970	-160473936.	3968.294	314853440.	-56001680.	6565.874
AV	412827.	-64849.	7.900	-215691.	5.334	423190.	-75271.	8.825
MONTHLY SUMMARY (NOV)								
MN	409142.	-156571.	7.901	-417901.	0.000	419476.	-200041.	8.825
MX	501861.	-6.	7.901	-417901.	0.000	510758.	-1.	8.825
SM	298807136.	-55069240.	5688.358	-300888608.	0.000	305934752.	-69652152.	6354.072
AV	415010.	-76485.	7.900	-417901.	0.000	424909.	-96739.	8.825
MONTHLY SUMMARY (DEC)								
MN	409142.	-219216.	7.901	-417901.	0.000	419476.	-286539.	8.825
MX	430006.	-16.	7.901	-417901.	0.000	440921.	-8124.	8.825
SM	304649664.	-94466696.	5877.970	-310918240.	0.000	312334784.	-118369544.	6565.874
AV	409475.	-126971.	7.900	-417901.	0.000	419805.	-159099.	8.825
YEARLY SUMMARY								
MN	375532.	-308752.	7.901	-417901.	0.000	384643.	-341310.	8.825
MX	501861.	0.	7.901	0.	26.763	510758.	0.	8.825
SM	3657932032.	-591890368.	69208.359	-1975835264.	20011.172	3763940352.	-619777216.	77307.875
AV	417572.	-67567.	7.900	-225552.	2.284	429674.	-70751.	8.825

MMDDHH	AC-17	AC-17	AC-17	AC-18	AC-18	AC-18	AC-18	AC-18
	HEATING CAPACITY BTU/HR	COOLING ELECTRIC KW	COOLING CAPACITY BTU/HR	TOT HTG COIL PWR BTU/HR	SUPPLY ELECTRIC KW	HEATING CAPACITY BTU/HR	COOLING ELECTRIC KW	COOLING CAPACITY BTU/HR
	----(78)	----(47)	----(70)	----(5)	----(49)	----(78)	----(47)	----(70)
MONTHLY SUMMARY (JAN)								
MN	-466808.	0.000	472365.	-333128.	8.825	-466808.	0.000	472365.
MX	-466808.	0.000	483672.	-27221.	8.825	-466808.	0.000	483672.
SM	-347305120.	0.000	351464192.	-134555616.	6565.874	-347305120.	0.000	351464192.
AV	-466808.	0.000	472398.	-180854.	8.825	-466808.	0.000	472398.
MONTHLY SUMMARY (FEB)								
MN	-466808.	0.000	472365.	-341310.	8.825	-466808.	0.000	472365.
MX	-466808.	0.000	495930.	-14.	8.825	-466808.	0.000	495930.
SM	-313694944.	0.000	317648256.	-112733568.	5930.467	-313694944.	0.000	317648256.
AV	-466808.	0.000	472691.	-167758.	8.825	-466808.	0.000	472691.
MONTHLY SUMMARY (MAR)								
MN	-466808.	0.000	462989.	-268816.	8.825	-466808.	0.000	462989.
MX	-466808.	0.000	515465.	-9.	8.825	-466808.	0.000	515465.
SM	-347305120.	0.000	351815584.	-82664224.	6565.874	-347305120.	0.000	351815584.
AV	-466808.	0.000	472870.	-111108.	8.825	-466808.	0.000	472870.
MONTHLY SUMMARY (APR)								
MN	-466808.	0.000	467476.	-226514.	8.825	-466808.	0.000	467476.
MX	-466808.	0.000	538517.	-3.	8.825	-466808.	0.000	538517.
SM	-336101728.	0.000	342397120.	-45800404.	6354.072	-336101728.	0.000	342397120.
AV	-466808.	0.000	475552.	-63612.	8.825	-466808.	0.000	475552.
MONTHLY SUMMARY (MAY)								
MN	0.	0.000	433561.	0.	8.825	0.	0.000	433561.
MX	0.	19.201	531548.	0.	8.825	0.	19.201	531548.
SM	0.	2020.376	356919840.	0.	6565.874	0.	2020.376	356919840.
AV	0.	2.716	479731.	0.	8.825	0.	2.716	479731.
MONTHLY SUMMARY (JUN)								
MN	0.	0.000	435768.	0.	8.825	0.	0.000	435768.
MX	0.	37.567	533516.	0.	8.825	0.	37.567	533516.
SM	0.	7157.804	353443520.	0.	6354.072	0.	7157.804	353443520.
AV	0.	9.941	490894.	0.	8.825	0.	9.941	490894.
MONTHLY SUMMARY (JUL)								
MN	0.	0.000	440210.	0.	8.825	0.	0.000	440210.
MX	0.	40.472	545654.	0.	8.825	0.	40.472	545654.
SM	0.	10091.453	373160736.	0.	6565.874	0.	10091.453	373160736.
AV	0.	13.564	501560.	0.	8.825	0.	13.564	501560.

SH-1	AC-17	AC-17	AC-17	AC-18	AC-18	AC-18	AC-18	AC-18
	HEATING CAPACITY BTU/HR	COOLING ELECTRIC KW	COOLING CAPACITY BTU/HR	TOT HTG COIL PWR BTU/HR	SUPPLY ELECTRIC KW	HEATING CAPACITY BTU/HR	COOLING ELECTRIC KW	COOLING CAPACITY BTU/HR
	----(78)	----(47)	----(70)	----(5)	----(49)	----(78)	----(47)	----(70)
MONTHLY SUMMARY (AUG)								
MN	0.	0.000	452828.	0.	8.825	0.	0.000	452828.
MX	0.	37.347	538562.	0.	8.825	0.	37.347	538562.
SM	0.	9406.572	372887808.	0.	6565.874	0.	9406.572	372887808.
AV	0.	12.643	501193.	0.	8.825	0.	12.643	501193.
MONTHLY SUMMARY (SEP)								
MN	0.	0.000	452823.	0.	8.825	0.	0.000	452823.
MX	0.	33.081	543194.	0.	8.825	0.	33.081	543194.
SM	0.	5179.672	351935072.	0.	6354.072	0.	5179.672	351935072.
AV	0.	7.194	488799.	0.	8.825	0.	7.194	488799.
MONTHLY SUMMARY (OCT)								
MN	-466808.	0.000	446944.	-302681.	8.825	-466808.	0.000	446944.
MX	0.	19.153	518106.	0.	8.825	0.	19.153	518106.
SM	-179254256.	4464.248	355075008.	-56001680.	6565.874	-179254256.	4464.248	355075008.
AV	-240933.	6.000	477251.	-75271.	8.825	-240933.	6.000	477251.
MONTHLY SUMMARY (NOV)								
MN	-466808.	0.000	472365.	-200041.	8.825	-466808.	0.000	472365.
MX	-466808.	0.000	587273.	-1.	8.825	-466808.	0.000	587273.
SM	-336101728.	0.000	345492192.	-69652152.	6354.072	-336101728.	0.000	345492192.
AV	-466808.	0.000	479850.	-96739.	8.825	-466808.	0.000	479850.
MONTHLY SUMMARY (DEC)								
MN	-466808.	0.000	472365.	-286539.	8.825	-466808.	0.000	472365.
MX	-466808.	0.000	499070.	-8124.	8.825	-466808.	0.000	499070.
SM	-347305120.	0.000	351772384.	-118369544.	6565.874	-347305120.	0.000	351772384.
AV	-466808.	0.000	472812.	-159099.	8.825	-466808.	0.000	472812.
YEARLY SUMMARY								
MN	-466808.	0.000	433561.	-341310.	8.825	-466808.	0.000	433561.
MX	0.	40.472	587273.	0.	8.825	0.	40.472	587273.
SM	-2207068160.	38320.121	4224011776.	-619777216.	77307.875	-2207068160.	38320.121	4224011776.
AV	-251948.	4.374	482193.	-70751.	8.825	-251948.	4.374	482193.

MMDHH	AC-19	AC-19	AC-19	AC-19	AC-19	AC-13	AC-13	AC-13
	TOT HTG COIL PWR BTU/HR	SUPPLY ELECTRIC KW	HEATING CAPACITY BTU/HR	COOLING ELECTRIC KW	COOLING CAPACITY BTU/HR	TOT HTG COIL PWR BTU/HR	SUPPLY ELECTRIC KW	HEATING CAPACITY BTU/HR
	---- (5)	----(49)	---- (78)	----(47)	----(70)	----(5)	----(49)	----(78)
MONTHLY SUMMARY (JAN)								
MN	-333128.	8.825	-466808.	0.000	472365.	-149671.	3.781	-200008.
MK	-27221.	8.825	-466808.	0.000	483672.	-10755.	3.781	-200008.
SM	-134555616.	6565.874	-347305120.	0.000	351464192.	-66026048.	2813.212	-148806272.
AV	-180854.	8.825	-466808.	0.000	472398.	-88745.	3.781	-200008.
MONTHLY SUMMARY (FEB)								
MN	-341310.	8.825	-466808.	0.000	472365.	-159390.	3.781	-200008.
MK	-14.	8.825	-466808.	0.000	495930.	-12315.	3.781	-200008.
SM	-112733568.	5930.467	-313694944.	0.000	317648256.	-63339708.	2540.966	-134405648.
AV	-167758.	8.825	-466808.	0.000	472691.	-94256.	3.781	-200008.
MONTHLY SUMMARY (MAR)								
MN	-268816.	8.825	-466808.	0.000	462989.	-138160.	3.781	-200008.
MK	-9.	8.825	-466808.	0.000	515465.	-753.	3.781	-200008.
SM	-82664224.	6565.874	-347305120.	0.000	351815584.	-61209760.	2813.212	-148806272.
AV	-111108.	8.825	-466808.	0.000	472870.	-82271.	3.781	-200008.
MONTHLY SUMMARY (APR)								
MN	-226514.	8.825	-466808.	0.000	467476.	-124042.	3.781	-200008.
MK	-3.	8.825	-466808.	0.000	538517.	-10.	3.781	-200008.
SM	-45800404.	6354.072	-336101728.	0.000	342397120.	-49574688.	2722.463	-144006064.
AV	-63612.	8.825	-466808.	0.000	475552.	-68854.	3.781	-200008.
MONTHLY SUMMARY (MAY)								
MN	0.	8.825	0.	0.000	433561.	0.	3.781	0.
MK	0.	8.825	0.	19.201	531548.	0.	3.781	0.
SM	0.	6565.874	0.	2020.376	356919840.	0.	2813.212	0.
AV	0.	8.825	0.	2.716	479731.	0.	3.781	0.
MONTHLY SUMMARY (JUN)								
MN	0.	8.825	0.	0.000	435768.	0.	3.781	0.
MK	0.	8.825	0.	37.567	533516.	0.	3.781	0.
SM	0.	6354.072	0.	7157.804	353443520.	0.	2722.463	0.
AV	0.	8.825	0.	9.941	490894.	0.	3.781	0.
MONTHLY SUMMARY (JUL)								
MN	0.	8.825	0.	0.000	440210.	0.	3.781	0.
MK	0.	8.825	0.	40.472	545654.	0.	3.781	0.
SM	0.	6565.874	0.	10091.453	373160736.	0.	2813.212	0.
AV	0.	8.825	0.	13.564	501560.	0.	3.781	0.

	AC-19	AC-19	AC-19	AC-19	AC-19	AC-13	AC-13	AC-13
	TOT HTG COIL PWR BTU/HR	SUPPLY ELECTRIC KW	HEATING CAPACITY BTU/HR	COOLING ELECTRIC KW	COOLING CAPACITY BTU/HR	TOT HTG COIL PWR BTU/HR	SUPPLY ELECTRIC KW	HEATING CAPACITY BTU/HR
	---- (5)	----(49)	----(78)	----(47)	---- (70)	---- (5)	----(49)	----(78)
MONTHLY SUMMARY (AUG)								
MN	0.	8.825	0.	0.000	452828.	0.	3.781	0.
MX	0.	8.825	0.	37.347	538562.	0.	3.781	0.
SM	0.	6565.874	0.	9406.572	372887808.	0.	2813.212	0.
AV	0.	8.825	0.	12.643	501193.	0.	3.781	0.
MONTHLY SUMMARY (SEP)								
MN	0.	8.825	0.	0.000	452823.	0.	3.781	0.
MX	0.	8.825	0.	33.081	543194.	0.	3.781	0.
SM	0.	6354.072	0.	5179.672	351935072.	0.	2722.463	0.
AV	0.	8.825	0.	7.194	488799.	0.	3.781	0.
MONTHLY SUMMARY (OCT)								
MN	-302681.	8.825	-466808.	0.000	446944.	-125506.	3.781	-200008.
MX	0.	8.825	0.	19.153	518106.	0.	3.781	0.
SM	-56001680.	6565.874	-179254256.	4464.248	355075008.	-21612522.	2813.212	-76803240.
AV	-75271.	8.825	-240933.	6.000	477251.	-29049.	3.781	-103230.
MONTHLY SUMMARY (NOV)								
MN	-200041.	8.825	-466808.	0.000	472365.	-79371.	3.781	-200008.
MX	-1.	8.825	-466808.	0.000	587273.	-7.	3.781	-200008.
SM	-69652152.	6354.072	-336101728.	0.000	345492192.	-27002596.	2722.463	-144006064.
AV	-96739.	8.825	-466808.	0.000	479850.	-37504.	3.781	-200008.
MONTHLY SUMMARY (DEC)								
MN	-286539.	8.825	-466808.	0.000	472365.	-119318.	3.781	-200008.
MX	-8124.	8.825	-466808.	0.000	499070.	-15.	3.781	-200008.
SM	-118369544.	6565.874	-347305120.	0.000	351772384.	-49382872.	2813.212	-148806272.
AV	-159099.	8.825	-466808.	0.000	472812.	-66375.	3.781	-200008.
YEARLY SUMMARY								
MN	-341310.	8.825	-466808.	0.000	433561.	-159390.	3.781	-200008.
MX	0.	8.825	0.	40.472	587273.	0.	3.781	0.
SM	-619777216.	77307.875	-2207068160.	38320.121	4224011776.	-338148224.	33123.305	-945639872.
AV	-70751.	8.825	-251948.	4.374	482193.	-38601.	3.781	-107950.

MMDDHH AC-13 AC-13

COOLING COOLING
ELECTRIC CAPACITY
KW BTU/HR

----(47) ----(70)

MONTHLY SUMMARY (JAN)

MN	0.000	195857.
MX	0.000	199644.
SM	0.000	145723952.
AV	0.000	195866.

MONTHLY SUMMARY (FEB)

MN	0.000	195857.
MX	0.000	205766.
SM	0.000	131719976.
AV	0.000	196012.

MONTHLY SUMMARY (MAR)

MN	0.000	191969.
MX	0.000	212775.
SM	0.000	145870256.
AV	0.000	196062.

MONTHLY SUMMARY (APR)

MN	0.000	188556.
MX	0.000	216935.
SM	0.000	141715328.
AV	0.000	196827.

MONTHLY SUMMARY (MAY)

MN	0.000	179768.
MX	2.415	230297.
SM	17.618	147983856.
AV	0.024	198903.

MONTHLY SUMMARY (JUN)

MN	0.000	179768.
MX	12.182	232362.
SM	1003.464	148619760.
AV	1.394	206416.

MONTHLY SUMMARY (JUL)

MN	0.000	183344.
MX	14.985	244333.
SM	2343.014	158155200.
AV	3.149	212574.

	AC-13	AC-13
	COOLING ELECTRIC KW	COOLING CAPACITY BTU/HR
	----(47)	----(70)
MONTHLY SUMMARY (AUG)		
MN	0.000	187700.
MX	16.113	234822.
SM	3418.675	155782544.
AV	4.595	209385.
MONTHLY SUMMARY (SEP)		
MN	0.000	187134.
MX	15.093	235675.
SM	2091.929	146788160.
AV	2.905	203872.
MONTHLY SUMMARY (OCT)		
MN	0.000	185317.
MX	10.064	214783.
SM	2159.956	147222848.
AV	2.903	197880.
MONTHLY SUMMARY (NOV)		
MN	0.000	195857.
MX	0.000	242866.
SM	0.000	143048032.
AV	0.000	198678.
MONTHLY SUMMARY (DEC)		
MN	0.000	195857.
MX	0.000	209097.
SM	0.000	145869696.
AV	0.000	196061.
YEARLY SUMMARY		
MN	0.000	179768.
MX	16.113	244333.
SM	11034.655	1758499584.
AV	1.260	200742.

MMDDHH	AC-24	AC-24	AC-24	AC-24	AC-24
	TOT HTG COIL PWR BTU/HR	SUPPLY ELECTRIC KW	HEATING CAPACITY BTU/HR	COOLING ELECTRIC KW	COOLING CAPACITY BTU/HR
	----(5)	----(49)	----(78)	----(47)	----(70)
MONTHLY SUMMARY (JAN)					
MN	-61923.	1.198	-78047.	0.000	85477.
MX	0.	1.198	-78047.	0.000	110157.
SM	-22713954.	891.089	-58067176.	0.000	73002208.
AV	-30530.	1.198	-78047.	0.000	98121.
MONTHLY SUMMARY (FEB)					
MN	-69907.	1.198	-78047.	0.000	84635.
MX	0.	1.198	-78047.	0.000	110157.
SM	-19360416.	804.855	-52447768.	0.000	64817880.
AV	-28810.	1.198	-78047.	0.000	96455.
MONTHLY SUMMARY (MAR)					
MN	-52858.	1.198	-78047.	0.000	79471.
MX	0.	1.198	-78047.	0.000	102227.
SM	-13331051.	891.089	-58067176.	0.000	69090528.
AV	-17918.	1.198	-78047.	0.000	92864.
MONTHLY SUMMARY (APR)					
MN	-42204.	1.198	-78047.	0.000	79795.
MX	0.	1.198	-78047.	0.000	99360.
SM	-6732901.	862.344	-56194040.	0.000	64398296.
AV	-9351.	1.198	-78047.	0.000	89442.
MONTHLY SUMMARY (MAY)					
MN	0.	1.198	0.	0.000	74278.
MX	0.	1.198	0.	4.508	96089.
SM	0.	891.089	0.	451.593	63892800.
AV	0.	1.198	0.	0.607	85877.
MONTHLY SUMMARY (JUN)					
MN	0.	1.198	0.	0.000	74095.
MX	0.	1.198	0.	7.926	92511.
SM	0.	862.344	0.	1491.402	60718016.
AV	0.	1.198	0.	2.071	84331.
MONTHLY SUMMARY (JUL)					
MN	0.	1.198	0.	0.009	75982.
MX	0.	1.198	0.	8.244	93823.
SM	0.	891.089	0.	1986.496	63470100.
AV	0.	1.198	0.	2.670	85309.

	AC-24	AC-24	AC-24	AC-24	AC-24
	TOT HTG COIL PWR BTU/HR	SUPPLY ELECTRIC KW	HEATING CAPACITY BTU/HR	COOLING ELECTRIC KW	COOLING CAPACITY BTU/HR
	---- (5)	---- (49)	---- (78)	---- (47)	---- (70)
MONTHLY SUMMARY (AUG)					
MN	0.	1.198	0.	0.000	76442.
MX	0.	1.198	0.	7.826	92760.
SM	0.	891.089	0.	1897.669	63633780.
AV	0.	1.198	0.	2.551	85529.
MONTHLY SUMMARY (SEP)					
MN	0.	1.198	0.	0.000	76310.
MX	0.	1.198	0.	7.093	93763.
SM	0.	862.344	0.	1076.018	61240384.
AV	0.	1.198	0.	1.494	85056.
MONTHLY SUMMARY (OCT)					
MN	-58065.	1.198	-78047.	0.000	76571.
MX	0.	1.198	0.	3.953	97481.
SM	-3779157.	891.089	-29970144.	286.116	65008320.
AV	-5080.	1.198	-40282.	0.385	87377.
MONTHLY SUMMARY (NOV)					
MN	-39673.	1.198	-78047.	0.000	83800.
MX	0.	1.198	-78047.	0.000	101294.
SM	-11174628.	862.344	-56194040.	0.000	66623344.
AV	-15520.	1.198	-78047.	0.000	92532.
MONTHLY SUMMARY (DEC)					
MN	-54096.	1.198	-78047.	0.000	86326.
MX	0.	1.198	-78047.	0.000	105645.
SM	-19733188.	891.089	-58067176.	0.000	71565632.
AV	-26523.	1.198	-78047.	0.000	96190.
YEARLY SUMMARY					
MN	-69907.	1.198	-78047.	0.000	74095.
MX	0.	1.198	0.	8.244	110157.
SM	-96825296.	10491.855	-369007520.	7189.294	787461376.
AV	-11053.	1.198	-42124.	0.821	89893.

ENTECH ENGINEERING
READING, PA 19603
REPORT- PV-A EQUIPMENT SIZES

EZDOE - ELITE SOFTWARE DEVELOPMENT INC
FT. GEORGE G. MEADE

DOE-2.1D 6/ 7/1996 11:41:36 PDL RUN 1
EMCS FRASIBILITY STUDY
WEATHER FILE- BALTIMORE, MD

EQUIPMENT	NUMBER		NUMBER		NUMBER		NUMBER		NUMBER	
	SIZE	INSTD	SIZE	INSTD	SIZE	INSTD	SIZE	INSTD	SIZE	INSTD
	(MBTU/H)	AVAIL	(MBTU/H)	AVAIL	(MBTU/H)	AVAIL	(MBTU/H)	AVAIL	(MBTU/H)	AVAIL
HW-BOILER	2.500	2	2							

MO	UTILITY-	ELECTRICITY	NATURAL-GAS
	TOTAL (MBTU)	514.096	1769.902
JAN	PEAK (KBTU)	1369.055	4226.488
	DY/HR	31/ 7	31/ 6
	TOTAL (MBTU)	463.197	1510.983
FEB	PEAK (KBTU)	1369.055	4295.385
	DY/HR	4/ 7	12/13
	TOTAL (MBTU)	524.536	1204.990
MAR	PEAK (KBTU)	1314.055	3570.662
	DY/HR	31/17	5/ 8
	TOTAL (MBTU)	488.227	768.205
APR	PEAK (KBTU)	1314.055	2790.423
	DY/HR	29/ 7	9/ 8
	TOTAL (MBTU)	511.348	0.000
MAY	PEAK (KBTU)	1779.045	0.000
	DY/HR	26/16	31/ 1
	TOTAL (MBTU)	661.563	0.000
JUN	PEAK (KBTU)	2357.090	0.000
	DY/HR	29/16	30/ 1
	TOTAL (MBTU)	741.537	0.000
JUL	PEAK (KBTU)	2458.500	0.000
	DY/HR	25/16	31/ 1
	TOTAL (MBTU)	757.859	0.000
AUG	PEAK (KBTU)	2382.875	0.000
	DY/HR	18/17	31/ 1
	TOTAL (MBTU)	603.997	0.000
SEP	PEAK (KBTU)	2246.128	0.000
	DY/HR	2/14	30/ 1
	TOTAL (MBTU)	610.390	724.383
OCT	PEAK (KBTU)	1899.012	3839.353
	DY/HR	31/14	16/ 2
	TOTAL (MBTU)	482.121	975.057
NOV	PEAK (KBTU)	1314.055	2466.963
	DY/HR	30/14	23/ 6
	TOTAL (MBTU)	508.076	1540.904
DEC	PEAK (KBTU)	1314.055	3707.788
	DY/HR	30/ 9	22/ 5
	ONE YEAR	6866.946	8494.425
	USE/PEAK	2458.500	4295.385

ENTECH ENGINEERING
READING, PA 19603
REPORT- PS-D PLANT LOADS SATISFIED

BZDOE - ELITE SOFTWARE DEVELOPMENT INC
FT. GEORGE G. MEADE

DOB-2.1D 6/ 7/1996 11:41:36 PDL RUN 1
EMCS FEASIBILITY STUDY
WEATHER FILE- BALTIMORE, MD

HEATING LOADS	MBTU SUPPLIED	PCT OF TOTAL LOAD
-----	-----	-----
HW-BOILER	6179.6	100.0
	=====	=====
LOAD SATISFIED	6179.6	100.0
TOTAL LOAD ON PLANT	6179.6	
ELECTRICAL LOADS	MBTU SUPPLIED	PCT OF TOTAL LOAD
-----	-----	-----
ELECTRICITY	6866.9	100.0
	=====	=====
LOAD SATISFIED	6866.9	100.0
TOTAL LOAD ON PLANT	6866.9	

ENTECH ENGINEERING
READING, PA 19603
REPORT- PS-D PLANT LOADS SATISFIED

EZDOE - ELITE SOFTWARE DEVELOPMENT INC
FT. GEORGE G. MEADE

DOE-2.1D 6/ 7/1996 11:41:36 PDL RUN 1
EMCS FEASIBILITY STUDY
WEATHER FILE- BALTIMORE, MD
(CONTINUED)

SUMMARY OF LOADS MET

TYPE OF LOAD	TOTAL LOAD (MBTU)	LOAD SATISFIED (MBTU)	TOTAL OVERLOAD (MBTU)	PEAK OVERLOAD (MBTU)	HOURS OVERLOADED
HEATING LOADS	6179.6	6179.6	0.000	0.000	0
ELECTRICAL LOADS	6866.9	6866.9	0.000	0.000	0

ENTECH ENGINEERING
READING, PA 19603
REPORT- PS-H EQUIPMENT USE STATISTICS

EZDOE - ELITE SOFTWARE DEVELOPMENT INC
FT. GEORGE G. MEADE

DOE-2.1D 6/ 7/1996 11:41:36 PDL RUN 1
EMCS FEASIBILITY STUDY
WEATHER FILE- BALTIMORE, MD

EQUIPMENT	AVG	MAX	MON		SIZE OPER		SIZE OPER		SIZE OPER		SIZE OPER	
	OPER RATIO	LOAD (MBTU)	DAY HR		(MBTU)	HRS	(MBTU)	HRS	(MBTU)	HRS	(MBTU)	HRS
HW-BOILER	0.501	3.196	2	12 13	2.500	4933						

E Q U I P M E N T T O T A L S

HW-BOILER		140.9	
	NOMINAL SIZE (MBTU)		2.500
	NUMBER INSTALLED		2
	FIRST COST (K\$)	131.1	131.1
	ANNUAL COST (K\$)	4.2	4.2
	CYCLICAL COST (K\$)	5.7	5.7
	-----TOTAL----- (K\$)		140.9
<hr/>			
EQUIPMENT TOTAL		140.9	

ENERGY TYPE IN SITE MBTU -	ELECTRICITY	NATURAL-GAS
CATEGORY OF USE		
SPACE HEAT	248.99	8494.42
SPACE COOL	1115.64	0.00
HVAC AUX	2494.03	0.00
DOM HOT WTR	0.00	0.00
AUX SOLAR	0.00	0.00
LIGHTS	2005.27	0.00
VERT TRANS	0.00	0.00
MISC EQUIP	1002.63	0.00
	-----	-----
TOTAL	6866.56	8494.42

TOTAL SITE ENERGY 15361.37 MBTU 146.1 KBTU/SQFT-YR GROSS-AREA 146.1 KBTU/SQFT-YR NET-AREA
 TOTAL SOURCE ENERGY 29115.89 MBTU 276.9 KBTU/SQFT-YR GROSS-AREA 276.9 KBTU/SQFT-YR NET-AREA

PERCENT OF HOURS ANY SYSTEM ZONE OUTSIDE OF THROTTLING RANGE = 19.7
 PERCENT OF HOURS ANY PLANT LOAD NOT SATISFIED = 0.0

NOTE ELECTRICITY AND/OR FUEL USED TO GENERATE ELECTRICITY IS APPORTIONED BASED
 ON THE YEARLY DEMAND. ALL OTHER ENERGY TYPES ARE APPORTIONED HOURLY.

MMDDHH	HW-BOILE R LOAD BTU/HR	HW-BOILE R ELECTRIC USE BTU/HR	HW-BOILE R FUEL USE BTU/HR
	---- (1)	---- (3)	---- (4)
MONTHLY SUMMARY (JAN)			
MN	368933.	32466.	602889.
MX	3134271.	110000.	4226488.
SM	1313267840.	46796916.	1769901184.
AV	1765145.	62899.	2378900.
MONTHLY SUMMARY (FEB)			
MN	69405.	6108.	113418.
MX	3195766.	110000.	4295385.
SM	1117173376.	40795020.	1510983168.
AV	1662460.	60707.	2248487.
MONTHLY SUMMARY (MAR)			
MN	21992.	1935.	35939.
MX	2555466.	110000.	3570662.
SM	867902400.	37103960.	1204989312.
AV	1166536.	49871.	1619609.
MONTHLY SUMMARY (APR)			
MN	21200.	1866.	34644.
MX	2184384.	55000.	2790423.
SM	525761888.	29182856.	768204480.
AV	730225.	40532.	1066951.
MONTHLY SUMMARY (MAY)			
MN	0.	0.	0.
MX	0.	0.	0.
SM	0.	0.	0.
AV	0.	0.	0.
MONTHLY SUMMARY (JUN)			
MN	0.	0.	0.
MX	0.	0.	0.
SM	0.	0.	0.
AV	0.	0.	0.
MONTHLY SUMMARY (JUL)			
MN	0.	0.	0.
MX	0.	0.	0.
SM	0.	0.	0.
AV	0.	0.	0.

	HW-BOILE R LOAD BTU/HR ----(1)	HW-BOILE R ELECTRIC USE BTU/HR ----(3)	HW-BOILE R FUEL USE BTU/HR ----(4)
MONTHLY SUMMARY (AUG)			
MN	0.	0.	0.
MX	0.	0.	0.
SM	0.	0.	0.
AV	0.	0.	0.
MONTHLY SUMMARY (SEP)			
MN	0.	0.	0.
MX	0.	0.	0.
SM	0.	0.	0.
AV	0.	0.	0.
MONTHLY SUMMARY (OCT)			
MN	0.	0.	0.
MX	2791186.	110000.	3839353.
SM	525994368.	21174142.	724383296.
AV	706982.	28460.	973633.
MONTHLY SUMMARY (NOV)			
MN	21169.	1863.	34592.
MX	1886109.	55000.	2466963.
SM	685091392.	33142652.	975057216.
AV	951516.	46031.	1354246.
MONTHLY SUMMARY (DEC)			
MN	134096.	11800.	219132.
MX	2675523.	110000.	3707788.
SM	1144408320.	40775620.	1540904064.
AV	1538183.	54806.	2071108.
YEARLY SUMMARY			
MN	0.	0.	0.
MX	3195766.	110000.	4295385.
SM	6179599360.	248971168.	8494422528.
AV	705434.	28421.	969683.

ENTECH ENGINEERING READING, PA 19603 SH-1 = HOURLY-REPORT		EZDOE - ELITE SOFTWARE DEVELOPMENT INC FT. GEORGE G. MEADE				DOE-2.1D 6/7/1996 EMCS FEASIBILITY STUDY		13:25:46 SDL RUN 1 PAGE 1- 1	
MMDH	AC-13	AC-13	AC-13	AC-13	AC-13	AC-14	AC-14	AC-14	
	TOT HTG COIL PWR BTU/HR	SUPPLY ELECTRIC KW	HEATING CAPACITY BTU/HR	COOLING ELECTRIC KW	COOLING CAPACITY BTU/HR	TOT HTG COIL PWR BTU/HR	SUPPLY ELECTRIC KW	HEATING CAPACITY BTU/HR	
	---- (5)	----(49)	---- (78)	----(47)	---- (70)	---- (5)	---- (49)	----(78)	
MONTHLY SUMMARY (JAN)									
MN	-131525.	0.000	-130764.	0.000	0.	-298943.	0.000	-303525.	
MK	0.	2.836	0.	0.000	148448.	0.	6.583	0.	
SM	-22606260.	938.683	-43282804.	0.000	49136288.	-59543508.	2396.067	-110482952.	
AV	-30385.	1.262	-58176.	0.000	66043.	-80032.	3.221	-148499.	
MONTHLY SUMMARY (FEB)									
MN	-128349.	0.000	-130764.	0.000	0.	-295942.	0.000	-303525.	
MK	0.	2.836	0.	0.000	153860.	0.	6.583	0.	
SM	-23615998.	873.457	-40275240.	0.000	45762124.	-47836128.	2218.337	-102287800.	
AV	-35143.	1.300	-59933.	0.000	68098.	-71185.	3.301	-152214.	
MONTHLY SUMMARY (MAR)									
MN	-128488.	0.000	-130764.	0.000	0.	-281136.	0.000	-303525.	
MK	0.	2.836	0.	0.000	159137.	0.	6.583	0.	
SM	-24113732.	981.222	-45244260.	0.000	51395992.	-26230660.	2099.850	-96824352.	
AV	-32411.	1.319	-60812.	0.000	69081.	-35256.	2.822	-130140.	
MONTHLY SUMMARY (APR)									
MN	-124003.	0.000	-130764.	0.000	0.	-222802.	0.000	-303525.	
MK	0.	2.836	0.	0.000	162812.	0.	6.583	0.	
SM	-17672356.	896.145	-41321352.	0.000	47123376.	-9124763.	1862.876	-85897472.	
AV	-24545.	1.245	-57391.	0.000	65449.	-12673.	2.587	-119302.	
MONTHLY SUMMARY (MAY)									
MN	0.	2.836	0.	0.000	136253.	0.	0.000	0.	
MK	0.	2.836	0.	0.978	176062.	0.	6.583	0.	
SM	0.	2109.910	0.	2.250	112242576.	0.	3804.743	0.	
AV	0.	2.836	0.	0.003	150864.	0.	5.114	0.	
MONTHLY SUMMARY (JUN)									
MN	0.	2.836	0.	0.000	136253.	0.	0.000	0.	
MK	0.	2.836	0.	10.337	177885.	0.	6.583	0.	
SM	0.	2041.849	0.	737.383	112906032.	0.	2073.520	0.	
AV	0.	2.836	0.	1.024	156814.	0.	2.880	0.	
MONTHLY SUMMARY (JUL)									
MN	0.	0.000	0.	0.000	0.	0.	0.000	0.	
MK	0.	2.836	0.	12.945	184643.	0.	6.583	0.	
SM	0.	1999.310	0.	1762.351	113992232.	0.	1612.737	0.	
AV	0.	2.687	0.	2.369	153215.	0.	2.168	0.	

	AC-13	AC-13	AC-13	AC-13	AC-13	AC-14	AC-14	AC-14
	TOT HTG COIL PWR BTU/HR	SUPPLY ELECTRIC KW	HEATING CAPACITY BTU/HR	COOLING ELECTRIC KW	COOLING CAPACITY BTU/HR	TOT HTG COIL PWR BTU/HR	SUPPLY ELECTRIC KW	HEATING CAPACITY BTU/HR
	---- (5)	----(49)	----(78)	----(47)	----(70)	----(5)	----(49)	----(78)
MONTHLY SUMMARY (AUG)								
MN	0.	0.000	0.	0.000	0.	0.	0.000	0.
MX	0.	2.836	0.	14.406	181013.	0.	6.583	0.
SM	0.	1579.596	0.	2443.175	88217296.	0.	1895.789	0.
AV	0.	2.123	0.	3.284	118572.	0.	2.548	0.
MONTHLY SUMMARY (SEP)								
MN	0.	0.000	0.	0.000	0.	0.	0.000	0.
MX	0.	2.836	0.	13.871	178597.	0.	6.583	0.
SM	0.	1582.432	0.	1596.673	86327912.	0.	2619.875	0.
AV	0.	2.198	0.	2.218	119900.	0.	3.639	0.
MONTHLY SUMMARY (OCT)								
MN	-46873.	0.000	-130764.	0.000	0.	-223816.	0.000	-303525.
MX	0.	2.836	0.	8.720	164928.	0.	6.583	0.
SM	-911284.	1386.755	-17260816.	1026.755	73505584.	-10961684.	3027.996	-40065252.
AV	-1225.	1.864	-23200.	1.380	98798.	-14733.	4.070	-53851.
MONTHLY SUMMARY (NOV)								
MN	-106605.	0.000	-130764.	0.000	0.	-252467.	0.000	-303525.
MX	0.	2.836	0.	0.000	183448.	0.	6.583	0.
SM	-1658294.	680.616	-31383310.	0.000	36509448.	-20247980.	1895.789	-87415096.
AV	-2303.	0.945	-43588.	0.000	50708.	-28122.	2.633	-121410.
MONTHLY SUMMARY (DEC)								
MN	-126856.	0.000	-130764.	0.000	0.	-282825.	0.000	-303525.
MX	0.	2.836	0.	0.000	156879.	0.	6.583	0.
SM	-8918976.	745.842	-34390876.	0.000	39087388.	-47883080.	2303.910	-106233624.
AV	-11988.	1.002	-46224.	0.000	52537.	-64359.	3.097	-142787.
YEARLY SUMMARY								
MN	-131525.	0.000	-130764.	0.000	0.	-298943.	0.000	-303525.
MX	0.	2.836	0.	14.406	184643.	0.	6.583	0.
SM	-99496896.	15815.816	-253158656.	7568.587	856206272.	-221827808.	27811.488	-629206528.
AV	-11358.	1.805	-28899.	0.864	97740.	-25323.	3.175	-71827.

MMDDHH	AC-14	AC-14	AC-15	AC-15	AC-15	AC-15	AC-15	AC-15	AC-16
	COOLING ELECTRIC KW	COOLING CAPACITY BTU/HR	TOT HTG COIL PWR BTU/HR	SUPPLY ELECTRIC KW	HEATING CAPACITY BTU/HR	COOLING ELECTRIC KW	COOLING CAPACITY BTU/HR	TOT HTG COIL PWR BTU/HR	
	----(47)	----(70)	----(5)	----(49)	----(78)	----(47)	----(70)	----(5)	
MONTHLY SUMMARY (JAN)									
MN	0.000	0.	-298943.	0.000	-303525.	0.000	0.	-298943.	
MK	0.000	356316.	0.	6.583	0.	0.000	356316.	0.	
SM	0.000	129699088.	-59543508.	2396.067	-110482952.	0.000	129699088.	-59543508.	
AV	0.000	174327.	-80032.	3.221	-148499.	0.000	174327.	-80032.	
MONTHLY SUMMARY (FEB)									
MN	0.000	0.	-295942.	0.000	-303525.	0.000	0.	-295942.	
MK	0.000	363647.	0.	6.583	0.	0.000	363647.	0.	
SM	0.000	120110608.	-47836128.	2218.337	-102287800.	0.000	120110608.	-47836128.	
AV	0.000	178736.	-71185.	3.301	-152214.	0.000	178736.	-71185.	
MONTHLY SUMMARY (MAR)									
MN	0.000	0.	-281136.	0.000	-303525.	0.000	0.	-281136.	
MK	0.000	373773.	0.	6.583	0.	0.000	373773.	0.	
SM	0.000	113695856.	-26230660.	2099.850	-96824352.	0.000	113695856.	-26230660.	
AV	0.000	152817.	-35256.	2.822	-130140.	0.000	152817.	-35256.	
MONTHLY SUMMARY (APR)									
MN	0.000	0.	-222802.	0.000	-303525.	0.000	0.	-222802.	
MK	0.000	402814.	0.	6.583	0.	0.000	402814.	0.	
SM	0.000	101553880.	-9124763.	1862.876	-85897472.	0.000	101553880.	-9124763.	
AV	0.000	141047.	-12673.	2.587	-119302.	0.000	141047.	-12673.	
MONTHLY SUMMARY (MAY)									
MN	0.000	0.	0.	0.000	0.	0.000	0.	0.	
MK	17.382	398199.	0.	6.583	0.	17.382	398199.	0.	
SM	1356.236	208003312.	0.	3804.743	0.	1356.236	208003312.	0.	
AV	1.823	279574.	0.	5.114	0.	1.823	279574.	0.	
MONTHLY SUMMARY (JUN)									
MN	0.000	0.	0.	0.000	0.	0.000	0.	0.	
MK	35.262	405460.	0.	6.583	0.	35.262	405460.	0.	
SM	4418.213	115459456.	0.	2073.520	0.	4418.213	115459456.	0.	
AV	6.136	160360.	0.	2.880	0.	6.136	160360.	0.	
MONTHLY SUMMARY (JUL)									
MN	0.000	0.	0.	0.000	0.	0.000	0.	0.	
MK	37.343	391270.	0.	6.583	0.	37.343	391270.	0.	
SM	5402.632	89908760.	0.	1612.737	0.	5402.632	89908760.	0.	
AV	7.262	120845.	0.	2.168	0.	7.262	120845.	0.	

	AC-14	AC-14	AC-15	AC-15	AC-15	AC-15	AC-15	AC-16
	COOLING ELECTRIC KW	COOLING CAPACITY BTU/HR	TOT HTG COIL PWR BTU/HR	SUPPLY ELECTRIC KW	HEATING CAPACITY BTU/HR	COOLING ELECTRIC KW	COOLING CAPACITY BTU/HR	TOT HTG COIL PWR BTU/HR
	----(47)	----(70)	----(5)	----(49)	----(78)	----(47)	----(70)	----(5)
MONTHLY SUMMARY (AUG)								
MN	0.000	0.	0.	0.000	0.	0.000	0.	0.
MX	34.768	391500.	0.	6.583	0.	34.768	391500.	0.
SM	5792.264	105321168.	0.	1895.789	0.	5792.264	105321168.	0.
AV	7.785	141561.	0.	2.548	0.	7.785	141561.	0.
MONTHLY SUMMARY (SEP)								
MN	0.000	0.	0.	0.000	0.	0.000	0.	0.
MX	32.921	400116.	0.	6.583	0.	32.921	400116.	0.
SM	3230.391	144183392.	0.	2619.875	0.	3230.391	144183392.	0.
AV	4.487	200255.	0.	3.639	0.	4.487	200255.	0.
MONTHLY SUMMARY (OCT)								
MN	0.000	0.	-223816.	0.000	-303525.	0.000	0.	-223816.
MX	15.554	390553.	0.	6.583	0.	15.554	390553.	0.
SM	1672.247	165730208.	-10961684.	3027.996	-40065252.	1672.247	165730208.	-10961684.
AV	2.248	222756.	-14733.	4.070	-53851.	2.248	222756.	-14733.
MONTHLY SUMMARY (NOV)								
MN	0.000	0.	-252467.	0.000	-303525.	0.000	0.	-252467.
MX	0.000	439027.	0.	6.583	0.	0.000	439027.	0.
SM	0.000	104695056.	-20247980.	1895.789	-87415096.	0.000	104695056.	-20247980.
AV	0.000	145410.	-28122.	2.633	-121410.	0.000	145410.	-28122.
MONTHLY SUMMARY (DEC)								
MN	0.000	0.	-282825.	0.000	-303525.	0.000	0.	-282825.
MX	0.000	367939.	0.	6.583	0.	0.000	367939.	0.
SM	0.000	124755832.	-47883080.	2303.910	-106233624.	0.000	124755832.	-47883080.
AV	0.000	167683.	-64359.	3.097	-142787.	0.000	167683.	-64359.
YEARLY SUMMARY								
MN	0.000	0.	-298943.	0.000	-303525.	0.000	0.	-298943.
MX	37.343	439027.	0.	6.583	0.	37.343	439027.	0.
SM	21871.984	1523116544.	-221827808.	27811.488	-629206528.	21871.984	1523116544.	-221827808.
AV	2.497	173872.	-25323.	3.175	-71827.	2.497	173872.	-25323.

MMDDHH	AC-16	AC-16	AC-16	AC-16	AC-20	AC-20	AC-20	AC-20
	SUPPLY ELECTRIC KW	HEATING CAPACITY BTU/HR	COOLING ELECTRIC KW	COOLING CAPACITY BTU/HR	TOT HTG COIL PWR BTU/HR	SUPPLY ELECTRIC KW	HEATING CAPACITY BTU/HR	COOLING ELECTRIC KW
	----(49)	----(78)	----(47)	----(70)	----(5)	----(49)	----(78)	----(47)
MONTHLY SUMMARY (JAN)								
MN	0.000	-303525.	0.000	0.	-269057.	0.000	-273299.	0.000
MX	6.583	0.	0.000	356316.	0.	5.927	0.	0.000
SM	2396.067	-110482952.	0.000	129699088.	-70529448.	2667.196	-122984760.	0.000
AV	3.221	-148499.	0.000	174327.	-94798.	3.585	-165302.	0.000
MONTHLY SUMMARY (FEB)								
MN	0.000	-303525.	0.000	0.	-268800.	0.000	-273299.	0.000
MX	6.583	0.	0.000	363647.	0.	5.927	0.	0.000
SM	2218.337	-102287800.	0.000	120110608.	-55442016.	2311.569	-106586800.	0.000
AV	3.301	-152214.	0.000	178736.	-82503.	3.440	-158611.	0.000
MONTHLY SUMMARY (MAR)								
MN	0.000	-303525.	0.000	0.	-244110.	0.000	-273299.	0.000
MX	6.583	0.	0.000	373773.	0.	5.927	0.	0.000
SM	2099.850	-96824352.	0.000	113695856.	-35171512.	2216.736	-102214000.	0.000
AV	2.822	-130140.	0.000	152817.	-47274.	2.979	-137384.	0.000
MONTHLY SUMMARY (APR)								
MN	0.000	-303525.	0.000	0.	-199086.	0.000	-273299.	0.000
MX	6.583	0.	0.000	402814.	0.	5.927	0.	0.000
SM	1862.876	-85897472.	0.000	101553880.	-14702621.	1778.130	-81989824.	0.000
AV	2.587	-119302.	0.000	141047.	-20420.	2.470	-113875.	0.000
MONTHLY SUMMARY (MAY)								
MN	0.000	0.	0.000	0.	0.	0.000	0.	0.000
MX	6.583	0.	17.382	398199.	0.	5.927	0.	12.760
SM	3804.743	0.	1356.236	208003312.	0.	3627.385	0.	883.340
AV	5.114	0.	1.823	279574.	0.	4.876	0.	1.187
MONTHLY SUMMARY (JUN)								
MN	0.000	0.	0.000	0.	0.	0.000	0.	0.000
MX	6.583	0.	35.262	405460.	0.	5.927	0.	29.188
SM	2073.520	0.	4418.213	115459456.	0.	2068.558	0.	3276.481
AV	2.880	0.	6.136	160360.	0.	2.873	0.	4.551
MONTHLY SUMMARY (JUL)								
MN	0.000	0.	0.000	0.	0.	0.000	0.	0.000
MX	6.583	0.	37.343	391270.	0.	5.927	0.	31.881
SM	1612.737	0.	5402.632	89908760.	0.	1458.067	0.	4089.954
AV	2.168	0.	7.262	120845.	0.	1.960	0.	5.497

	AC-16	AC-16	AC-16	AC-16	AC-20	AC-20	AC-20	AC-20
	SUPPLY ELECTRIC KW	HEATING CAPACITY BTU/HR	COOLING ELECTRIC KW	COOLING CAPACITY BTU/HR	TOT HTG COIL PWR BTU/HR	SUPPLY ELECTRIC KW	HEATING CAPACITY BTU/HR	COOLING ELECTRIC KW
	---- (49)	---- (78)	---- (47)	---- (70)	---- (5)	---- (49)	---- (78)	---- (47)
MONTHLY SUMMARY (AUG)								
MN	0.000	0.	0.000	0.	0.	0.000	0.	0.000
MK	6.583	0.	34.768	391500.	0.	5.927	0.	28.291
SM	1895.789	0.	5792.264	105321168.	0.	1908.527	0.	4355.642
AV	2.548	0.	7.785	141561.	0.	2.565	0.	5.854
MONTHLY SUMMARY (SEP)								
MN	0.000	0.	0.000	0.	0.	0.000	0.	0.000
MK	6.583	0.	32.921	400116.	0.	5.927	0.	26.309
SM	2619.875	0.	3230.391	144183392.	0.	2679.049	0.	2235.089
AV	3.639	0.	4.487	200255.	0.	3.721	0.	3.104
MONTHLY SUMMARY (OCT)								
MN	0.000	-303525.	0.000	0.	-197149.	0.000	-273299.	0.000
MK	6.583	0.	15.554	390553.	0.	5.927	0.	11.882
SM	3027.996	-40065252.	1672.247	165730208.	-13992087.	2969.478	-41814816.	1249.103
AV	4.070	-53851.	2.248	222756.	-18807.	3.991	-56203.	1.679
MONTHLY SUMMARY (NOV)								
MN	0.000	-303525.	0.000	0.	-214652.	0.000	-273299.	0.000
MK	6.583	0.	0.000	439027.	0.	5.927	0.	0.000
SM	1895.789	-87415096.	0.000	104695056.	-28612662.	2104.121	-97021320.	0.000
AV	2.633	-121410.	0.000	145410.	-39740.	2.922	-134752.	0.000
MONTHLY SUMMARY (DEC)								
MN	0.000	-303525.	0.000	0.	-258971.	0.000	-273299.	0.000
MK	6.583	0.	0.000	367939.	0.	5.927	0.	0.000
SM	2303.910	-106233624.	0.000	124755832.	-59568512.	2554.581	-117792072.	0.000
AV	3.097	-142787.	0.000	167683.	-80065.	3.434	-158323.	0.000
YEARLY SUMMARY								
MN	0.000	-303525.	0.000	0.	-269057.	0.000	-273299.	0.000
MK	6.583	0.	37.343	439027.	0.	5.927	0.	31.881
SM	27811.488	-629206528.	21871.984	1523116544.	-278018848.	28343.396	-670403584.	16089.609
AV	3.175	-71827.	2.497	173872.	-31737.	3.236	-76530.	1.837

MMDH	AC-20	AC-22	AC-22	AC-22	AC-22	AC-22	AC-17	AC-17
	COOLING CAPACITY BTU/HR	TOT HTG COIL PWR BTU/HR	SUPPLY ELECTRIC KW	HEATING CAPACITY BTU/HR	COOLING ELECTRIC KW	COOLING CAPACITY BTU/HR	TOT HTG COIL PWR BTU/HR	SUPPLY ELECTRIC KW
	----(70)	----(5)	----(49)	----(78)	----(47)	----(70)	----(5)	----(49)
MONTHLY SUMMARY (JAN)								
MN	0.	-131525.	0.000	-130764.	0.000	0.	-300959.	0.000
MK	310378.	0.	2.836	0.	0.000	148448.	0.	6.631
SM	139670224.	-22606260.	938.683	-43282804.	0.000	49136288.	-58536560.	2393.755
AV	187729.	-30385.	1.262	-58176.	0.000	66043.	-78678.	3.217
MONTHLY SUMMARY (FEB)								
MN	0.	-128349.	0.000	-130764.	0.000	0.	-297413.	0.000
MK	315346.	0.	2.836	0.	0.000	153860.	0.	6.631
SM	121063216.	-23615998.	873.457	-40275240.	0.000	45762124.	-47102664.	2227.982
AV	180154.	-35143.	1.300	-59933.	0.000	68098.	-70093.	3.315
MONTHLY SUMMARY (MAR)								
MN	0.	-128488.	0.000	-130764.	0.000	0.	-281201.	0.000
MK	324964.	0.	2.836	0.	0.000	159137.	0.	6.631
SM	116091384.	-24113732.	981.222	-45244260.	0.000	51395992.	-25557344.	2108.626
AV	156037.	-32411.	1.319	-60812.	0.000	69081.	-34351.	2.834
MONTHLY SUMMARY (APR)								
MN	0.	-124003.	0.000	-130764.	0.000	0.	-224353.	0.000
MK	347670.	0.	2.836	0.	0.000	162812.	0.	6.631
SM	93581096.	-17672356.	896.145	-41321352.	0.000	47123376.	-8956861.	1869.914
AV	129974.	-24545.	1.245	-57391.	0.000	65449.	-12440.	2.597
MONTHLY SUMMARY (MAY)								
MN	0.	0.	2.836	0.	0.000	136253.	0.	0.000
MK	357339.	0.	2.836	0.	0.978	176062.	0.	6.631
SM	192488944.	0.	2109.910	0.	2.250	112242576.	0.	3766.351
AV	258722.	0.	2.836	0.	0.003	150864.	0.	5.062
MONTHLY SUMMARY (JUN)								
MN	0.	0.	2.836	0.	0.000	136253.	0.	0.000
MK	355950.	0.	2.836	0.	10.337	177885.	0.	6.631
SM	111772288.	0.	2041.849	0.	737.383	112906032.	0.	2009.162
AV	155239.	0.	2.836	0.	1.024	156814.	0.	2.791
MONTHLY SUMMARY (JUL)								
MN	0.	0.	0.000	0.	0.000	0.	0.	0.000
MK	344944.	0.	2.836	0.	12.945	184643.	0.	6.631
SM	78810816.	0.	1999.310	0.	1762.351	113992232.	0.	1624.570
AV	105929.	0.	2.687	0.	2.369	153215.	0.	2.184

	AC-20	AC-22	AC-22	AC-22	AC-22	AC-22	AC-17	AC-17
	COOLING CAPACITY BTU/HR	TOT HTG COIL PWR BTU/HR	SUPPLY ELECTRIC KW	HEATING CAPACITY BTU/HR	COOLING ELECTRIC KW	COOLING CAPACITY BTU/HR	TOT HTG COIL PWR BTU/HR	SUPPLY ELECTRIC KW
	----(70)	----(5)	----(49)	----(78)	----(47)	----(70)	----(5)	----(49)
MONTHLY SUMMARY (AUG)								
MN	0.	0.	0.000	0.	0.000	0.	0.	0.000
MK	354404.	0.	2.836	0.	14.406	181013.	0.	6.631
SM	103205528.	0.	1579.596	0.	2443.175	88217296.	0.	1889.806
AV	138717.	0.	2.123	0.	3.284	118572.	0.	2.540
MONTHLY SUMMARY (SEP)								
MN	0.	0.	0.000	0.	0.000	0.	0.	0.000
MK	347153.	0.	2.836	0.	13.871	178597.	0.	6.631
SM	142388384.	0.	1582.432	0.	1596.673	86327912.	0.	2513.111
AV	197762.	0.	2.198	0.	2.218	119900.	0.	3.490
MONTHLY SUMMARY (OCT)								
MN	0.	-46873.	0.000	-130764.	0.000	0.	-225000.	0.000
MK	338178.	0.	2.836	0.	8.720	164928.	0.	6.631
SM	156917280.	-911284.	1386.755	-17260816.	1026.755	73505584.	-10824150.	3010.429
AV	210910.	-1225.	1.864	-23200.	1.380	98798.	-14549.	4.046
MONTHLY SUMMARY (NOV)								
MN	0.	-106605.	0.000	-130764.	0.000	0.	-253894.	0.000
MK	379337.	0.	2.836	0.	0.000	183448.	0.	6.631
SM	111854640.	-1658294.	680.616	-31383310.	0.000	36509448.	-19589902.	1896.437
AV	155354.	-2303.	0.945	-43588.	0.000	50708.	-27208.	2.634
MONTHLY SUMMARY (DEC)								
MN	0.	-126856.	0.000	-130764.	0.000	0.	-279104.	0.000
MK	318633.	0.	2.836	0.	0.000	156879.	0.	6.631
SM	133799504.	-8918976.	745.842	-34390876.	0.000	39087388.	-46783972.	2314.184
AV	179838.	-11988.	1.002	-46224.	0.000	52537.	-62882.	3.110
YEARLY SUMMARY								
MN	0.	-131525.	0.000	-130764.	0.000	0.	-300959.	0.000
MK	379337.	0.	2.836	0.	14.406	184643.	0.	6.631
SM	1501643264.	-99496896.	15815.816	-253158656.	7568.587	856206272.	-217351440.	27624.328
AV	171420.	-11358.	1.805	-28899.	0.864	97740.	-24812.	3.153

MDDHH	AC-17	AC-17	AC-17	AC-18	AC-18	AC-18	AC-18	AC-18
	HEATING CAPACITY BTU/HR	COOLING ELECTRIC KW	COOLING CAPACITY BTU/HR	TOT HTG COIL PWR BTU/HR	SUPPLY ELECTRIC KW	HEATING CAPACITY BTU/HR	COOLING ELECTRIC KW	COOLING CAPACITY BTU/HR
	----(78)	----(47)	----(70)	----(5)	----(49)	----(78)	----(47)	----(70)
MONTHLY SUMMARY (JAN)								
MN	-305752.	0.000	0.	-300959.	0.000	-305752.	0.000	0.
MX	0.	0.000	361511.	0.	6.631	0.	0.000	361511.
SM	-110376400.	0.000	130505600.	-58536560.	2393.755	-110376400.	0.000	130505600.
AV	-148355.	0.000	175411.	-78678.	3.217	-148355.	0.000	175411.
MONTHLY SUMMARY (FEB)								
MN	-305752.	0.000	0.	-297413.	0.000	-305752.	0.000	0.
MX	0.	0.000	371984.	0.	6.631	0.	0.000	371984.
SM	-102732608.	0.000	121535736.	-47102664.	2227.982	-102732608.	0.000	121535736.
AV	-152876.	0.000	180857.	-70093.	3.315	-152876.	0.000	180857.
MONTHLY SUMMARY (MAR)								
MN	-305752.	0.000	0.	-281201.	0.000	-305752.	0.000	0.
MX	0.	0.000	381522.	0.	6.631	0.	0.000	381522.
SM	-97229072.	0.000	115018616.	-25557344.	2108.626	-97229072.	0.000	115018616.
AV	-130684.	0.000	154595.	-34351.	2.834	-130684.	0.000	154595.
MONTHLY SUMMARY (APR)								
MN	-305752.	0.000	0.	-224353.	0.000	-305752.	0.000	0.
MX	0.	0.000	411846.	0.	6.631	0.	0.000	411846.
SM	-86222000.	0.000	102817784.	-8956861.	1869.914	-86222000.	0.000	102817784.
AV	-119753.	0.000	142802.	-12440.	2.597	-119753.	0.000	142802.
MONTHLY SUMMARY (MAY)								
MN	0.	0.000	0.	0.	0.000	0.	0.000	0.
MX	0.	18.077	395666.	0.	6.631	0.	18.077	395666.
SM	0.	1391.492	207447248.	0.	3766.351	0.	1391.492	207447248.
AV	0.	1.870	278827.	0.	5.062	0.	1.870	278827.
MONTHLY SUMMARY (JUN)								
MN	0.	0.000	0.	0.	0.000	0.	0.000	0.
MX	0.	35.969	411358.	0.	6.631	0.	35.969	411358.
SM	0.	4444.841	112819016.	0.	2009.162	0.	4444.841	112819016.
AV	0.	6.173	156693.	0.	2.791	0.	6.173	156693.
MONTHLY SUMMARY (JUL)								
MN	0.	0.000	0.	0.	0.000	0.	0.000	0.
MX	0.	37.778	397826.	0.	6.631	0.	37.778	397826.
SM	0.	5506.276	91415984.	0.	1624.570	0.	5506.276	91415984.
AV	0.	7.401	122871.	0.	2.184	0.	7.401	122871.

	AC-17	AC-17	AC-17	AC-18	AC-18	AC-18	AC-18	AC-18
	HEATING CAPACITY BTU/HR	COOLING ELECTRIC KW	COOLING CAPACITY BTU/HR	TOT HTG COIL PWR BTU/HR	SUPPLY ELBCTRIC KW	HEATING CAPACITY BTU/HR	COOLING ELECTRIC KW	COOLING CAPACITY BTU/HR
	----(78)	----(47)	----(70)	----(5)	----(49)	----(78)	----(47)	----(70)
MONTHLY SUMMARY (AUG)								
MN	0.	0.000	0.	0.	0.000	0.	0.000	0.
MK	0.	35.331	401061.	0.	6.631	0.	35.331	401061.
SM	0.	5897.169	105953968.	0.	1889.806	0.	5897.169	105953968.
AV	0.	7.926	142411.	0.	2.540	0.	7.926	142411.
MONTHLY SUMMARY (SEP)								
MN	0.	0.000	0.	0.	0.000	0.	0.000	0.
MK	0.	33.682	405884.	0.	6.631	0.	33.682	405884.
SM	0.	3321.461	139652608.	0.	2513.111	0.	3321.461	139652608.
AV	0.	4.613	193962.	0.	3.490	0.	4.613	193962.
MONTHLY SUMMARY (OCT)								
MN	-305752.	0.000	0.	-225000.	0.000	-305752.	0.000	0.
MK	0.	16.229	396188.	0.	6.631	0.	16.229	396188.
SM	-40359224.	1731.307	166117456.	-10824150.	3010.429	-40359224.	1731.307	166117456.
AV	-54246.	2.327	223276.	-14549.	4.046	-54246.	2.327	223276.
MONTHLY SUMMARY (NOV)								
MN	-305752.	0.000	0.	-253894.	0.000	-305752.	0.000	0.
MK	0.	0.000	448637.	0.	6.631	0.	0.000	448637.
SM	-87445008.	0.000	105633504.	-19589902.	1896.437	-87445008.	0.000	105633504.
AV	-121451.	0.000	146713.	-27208.	2.634	-121451.	0.000	146713.
MONTHLY SUMMARY (DEC)								
MN	-305752.	0.000	0.	-279104.	0.000	-305752.	0.000	0.
MK	0.	0.000	376381.	0.	6.631	0.	0.000	376381.
SM	-106707376.	0.000	126235472.	-46783972.	2314.184	-106707376.	0.000	126235472.
AV	-143424.	0.000	169671.	-62882.	3.110	-143424.	0.000	169671.
YEARLY SUMMARY								
MN	-305752.	0.000	0.	-300959.	0.000	-305752.	0.000	0.
MK	0.	37.778	448637.	0.	6.631	0.	37.778	448637.
SM	-631071680.	22292.547	1525153152.	-217351440.	27624.328	-631071680.	22292.547	1525153152.
AV	-72040.	2.545	174104.	-24812.	3.153	-72040.	2.545	174104.

MDDHH	AC-19	AC-19	AC-19	AC-19	AC-19	AC-13	AC-13	AC-13
	TOT HTG COIL PWR BTU/HR	SUPPLY ELECTRIC KW	HEATING CAPACITY BTU/HR	COOLING ELECTRIC KW	COOLING CAPACITY BTU/HR	TOT HTG COIL PWR BTU/HR	SUPPLY ELECTRIC KW	HEATING CAPACITY BTU/HR
	---- (5)	----(49)	----(78)	----(47)	----(70)	----(5)	----(49)	----(78)
MONTHLY SUMMARY (JAN)								
MN	-300959.	0.000	-305752.	0.000	0.	-131525.	0.000	-130764.
MK	0.	6.631	0.	0.000	361511.	0.	2.836	0.
SM	-58536560.	2393.755	-110376400.	0.000	130505600.	-22606260.	938.683	-43282804.
AV	-78678.	3.217	-148355.	0.000	175411.	-30385.	1.262	-58176.
MONTHLY SUMMARY (FEB)								
MN	-297413.	0.000	-305752.	0.000	0.	-128349.	0.000	-130764.
MK	0.	6.631	0.	0.000	371984.	0.	2.836	0.
SM	-47102664.	2227.982	-102732608.	0.000	121535736.	-23615998.	873.457	-40275240.
AV	-70093.	3.315	-152876.	0.000	180857.	-35143.	1.300	-59933.
MONTHLY SUMMARY (MAR)								
MN	-281201.	0.000	-305752.	0.000	0.	-128488.	0.000	-130764.
MK	0.	6.631	0.	0.000	381522.	0.	2.836	0.
SM	-25557344.	2108.626	-97229072.	0.000	115018616.	-24113732.	981.222	-45244260.
AV	-34351.	2.834	-130684.	0.000	154595.	-32411.	1.319	-60812.
MONTHLY SUMMARY (APR)								
MN	-224353.	0.000	-305752.	0.000	0.	-124003.	0.000	-130764.
MK	0.	6.631	0.	0.000	411846.	0.	2.836	0.
SM	-8956861.	1869.914	-86222000.	0.000	102817784.	-17672356.	896.145	-41321352.
AV	-12440.	2.597	-119753.	0.000	142802.	-24545.	1.245	-57391.
MONTHLY SUMMARY (MAY)								
MN	0.	0.000	0.	0.000	0.	0.	2.836	0.
MK	0.	6.631	0.	18.077	395666.	0.	2.836	0.
SM	0.	3766.351	0.	1391.492	207447248.	0.	2109.910	0.
AV	0.	5.062	0.	1.870	278827.	0.	2.836	0.
MONTHLY SUMMARY (JUN)								
MN	0.	0.000	0.	0.000	0.	0.	2.836	0.
MK	0.	6.631	0.	35.969	411358.	0.	2.836	0.
SM	0.	2009.162	0.	4444.841	112819016.	0.	2041.849	0.
AV	0.	2.791	0.	6.173	156693.	0.	2.836	0.
MONTHLY SUMMARY (JUL)								
MN	0.	0.000	0.	0.000	0.	0.	0.000	0.
MK	0.	6.631	0.	37.778	397826.	0.	2.836	0.
SM	0.	1624.570	0.	5506.276	91415984.	0.	1999.310	0.
AV	0.	2.184	0.	7.401	122871.	0.	2.687	0.

	AC-19	AC-19	AC-19	AC-19	AC-19	AC-13	AC-13	AC-13
	TOT HTG COIL PWR BTU/HR	SUPPLY ELECTRIC KW	HEATING CAPACITY BTU/HR	COOLING ELECTRIC KW	COOLING CAPACITY BTU/HR	TOT HTG COIL PWR BTU/HR	SUPPLY ELECTRIC KW	HEATING CAPACITY BTU/HR
	---- (5)	---- (49)	---- (78)	---- (47)	---- (70)	---- (5)	---- (49)	---- (78)
MONTHLY SUMMARY (AUG)								
MN	0.	0.000	0.	0.000	0.	0.	0.000	0.
MX	0.	6.631	0.	35.331	401061.	0.	2.836	0.
SM	0.	1889.806	0.	5897.169	105953968.	0.	1579.596	0.
AV	0.	2.540	0.	7.926	142411.	0.	2.123	0.
MONTHLY SUMMARY (SEP)								
MN	0.	0.000	0.	0.000	0.	0.	0.000	0.
MX	0.	6.631	0.	33.682	405884.	0.	2.836	0.
SM	0.	2513.111	0.	3321.461	139652608.	0.	1582.432	0.
AV	0.	3.490	0.	4.613	193962.	0.	2.198	0.
MONTHLY SUMMARY (OCT)								
MN	-225000.	0.000	-305752.	0.000	0.	-46873.	0.000	-130764.
MX	0.	6.631	0.	16.229	396188.	0.	2.836	0.
SM	-10824150.	3010.429	-40359224.	1731.307	166117456.	-911284.	1386.755	-17260816.
AV	-14549.	4.046	-54246.	2.327	223276.	-1225.	1.864	-23200.
MONTHLY SUMMARY (NOV)								
MN	-253894.	0.000	-305752.	0.000	0.	-106605.	0.000	-130764.
MX	0.	6.631	0.	0.000	448637.	0.	2.836	0.
SM	-19589902.	1896.437	-87445008.	0.000	105633504.	-1658294.	680.616	-31383310.
AV	-27208.	2.634	-121451.	0.000	146713.	-2303.	0.945	-43588.
MONTHLY SUMMARY (DEC)								
MN	-279104.	0.000	-305752.	0.000	0.	-126856.	0.000	-130764.
MX	0.	6.631	0.	0.000	376381.	0.	2.836	0.
SM	-46783972.	2314.184	-106707376.	0.000	126235472.	-8918976.	745.842	-34390876.
AV	-62882.	3.110	-143424.	0.000	169671.	-11988.	1.002	-46224.
YEARLY SUMMARY								
MN	-300959.	0.000	-305752.	0.000	0.	-131525.	0.000	-130764.
MX	0.	6.631	0.	37.778	448637.	0.	2.836	0.
SM	-217351440.	27624.328	-631071680.	22292.547	1525153152.	-99496896.	15815.816	-253158656.
AV	-24812.	3.153	-72040.	2.545	174104.	-11358.	1.805	-28899.

MMDDHH	AC-13	AC-13	AC-24	AC-24	AC-24	AC-24	AC-24
	COOLING ELECTRIC KW	COOLING CAPACITY BTU/HR	TOT RTG COIL PWR BTU/HR	SUPPLY ELECTRIC KW	HEATING CAPACITY BTU/HR	COOLING ELECTRIC KW	COOLING CAPACITY BTU/HR
	----(47)	----(70)	----(5)	----(49)	----(78)	----(47)	----(70)
MONTHLY SUMMARY (JAN)							
MN	0.000	0.	-85952.	0.000	-87582.	0.000	0.
MX	0.000	148448.	0.	1.198	0.	0.000	110157.
SM	0.000	49136288.	-10642578.	402.427	-29427552.	0.000	32943498.
AV	0.000	66043.	-14305.	0.541	-39553.	0.000	44279.
MONTHLY SUMMARY (FEB)							
MN	0.000	0.	-84210.	0.000	-87582.	0.000	0.
MX	0.000	153860.	0.	1.198	0.	0.000	110157.
SM	0.000	45762124.	-8433313.	376.078	-27500748.	0.000	29935714.
AV	0.000	68098.	-12550.	0.560	-40924.	0.000	44547.
MONTHLY SUMMARY (MAR)							
MN	0.000	0.	-75638.	0.000	-87582.	0.000	0.
MX	0.000	159137.	0.	1.198	0.	0.000	101265.
SM	0.000	51395992.	-4027969.	368.892	-26975256.	0.000	28272208.
AV	0.000	69081.	-5414.	0.496	-36257.	0.000	38000.
MONTHLY SUMMARY (APR)							
MN	0.000	0.	-54515.	0.000	-87582.	0.000	0.
MX	0.000	162812.	0.	1.198	0.	0.000	99360.
SM	0.000	47123376.	-995566.	318.588	-23296812.	0.000	23600840.
AV	0.000	65449.	-1383.	0.442	-32357.	0.000	32779.
MONTHLY SUMMARY (MAY)							
MN	0.000	136253.	0.	0.000	0.	0.000	0.
MX	0.978	176062.	0.	1.198	0.	4.755	96089.
SM	2.250	112242576.	0.	561.721	0.	389.593	40439912.
AV	0.003	150864.	0.	0.755	0.	0.524	54355.
MONTHLY SUMMARY (JUN)							
MN	0.000	136253.	0.	0.000	0.	0.000	0.
MX	10.337	177885.	0.	1.198	0.	8.323	89590.
SM	737.383	112906032.	0.	316.193	0.	1126.549	21829526.
AV	1.024	156814.	0.	0.439	0.	1.565	30319.
MONTHLY SUMMARY (JUL)							
MN	0.000	0.	0.	0.000	0.	0.000	0.
MX	12.945	184643.	0.	1.198	0.	8.496	88057.
SM	1762.351	113992232.	0.	287.448	0.	1306.115	19853546.
AV	2.369	153215.	0.	0.386	0.	1.756	26685.

	AC-13	AC-13	AC-24	AC-24	AC-24	AC-24	AC-24
	COOLING ELECTRIC KW	COOLING CAPACITY BTU/HR	TOT HTG COIL PWR BTU/HR	SUPPLY ELECTRIC KW	HEATING CAPACITY BTU/HR	COOLING ELECTRIC KW	COOLING CAPACITY BTU/HR
	----(47)	----(70)	----(5)	----(49)	----(78)	----(47)	----(70)
MONTHLY SUMMARY (AUG)							
MN	0.000	0.	0.	0.000	0.	0.000	0.
MK	14.406	181013.	0.	1.198	0.	8.223	88188.
SM	2443.175	88217296.	0.	330.565	0.	1414.025	22735698.
AV	3.284	118572.	0.	0.444	0.	1.901	30559.
MONTHLY SUMMARY (SEP)							
MN	0.000	0.	0.	0.000	0.	0.000	0.
MK	13.871	178597.	0.	1.198	0.	7.855	91109.
SM	1596.673	86327912.	0.	338.949	0.	857.148	23574512.
AV	2.218	119900.	0.	0.471	0.	1.190	32742.
MONTHLY SUMMARY (OCT)							
MN	0.000	0.	-44750.	0.000	-87582.	0.000	0.
MK	8.720	164928.	0.	1.198	0.	4.176	97481.
SM	1026.755	73505584.	-308914.	479.080	-11560824.	221.410	34647744.
AV	1.380	98798.	-415.	0.644	-15539.	0.298	46570.
MONTHLY SUMMARY (NOV)							
MN	0.000	0.	-67922.	0.000	-87582.	0.000	0.
MK	0.000	183448.	0.	1.198	0.	0.000	100839.
SM	0.000	36509448.	-2956222.	320.984	-23471976.	0.000	24719602.
AV	0.000	50708.	-4106.	0.446	-32600.	0.000	34333.
MONTHLY SUMMARY (DEC)							
MN	0.000	0.	-75813.	0.000	-87582.	0.000	0.
MK	0.000	156879.	0.	1.198	0.	0.000	105645.
SM	0.000	39087388.	-7977921.	390.450	-28551732.	0.000	31126806.
AV	0.000	52537.	-10723.	0.525	-38376.	0.000	41837.
YEARLY SUMMARY							
MN	0.000	0.	-85952.	0.000	-87582.	0.000	0.
MK	14.406	184643.	0.	1.198	0.	8.496	110157.
SM	7568.587	856206272.	-35342484.	4491.376	-170784896.	5314.840	333679648.
AV	0.864	97740.	-4035.	0.513	-19496.	0.607	38091.

ENTECH ENGINEERING
READING, PA 19603
REPORT- PV-A EQUIPMENT SIZES

EZDOE - ELITE SOFTWARE DEVELOPMENT INC
FT. GEORGE G. MEADE

DOE-2.1D 6/ 7/1996 13:25:46 PDL RUN 1
EMCS FEASIBILITY STUDY
WEATHER FILE- BALTIMORE, MD

EQUIPMENT	NUMBER		NUMBER		NUMBER		NUMBER		NUMBER	
	SIZE	INSTD	SIZE	INSTD	SIZE	INSTD	SIZE	INSTD	SIZE	INSTD
	(MBTU/H)	AVAIL	(MBTU/H)	AVAIL	(MBTU/H)	AVAIL	(MBTU/H)	AVAIL	(MBTU/H)	AVAIL
HW-BOILER	2.500	2	2							

S I T E E N E R G Y													* SOURCE
	2	3	4	5	6	7	8	9	10	11	12	13	14
MONTH	TOTAL HEAT LOAD	TOTAL COOLING LOAD	TOTAL ELECTR LOAD	RCVRED ENERGY	WASTED RCVRABL ENERGY	FUEL INPUT COOLING	ELEC INPUT COOLING	FUEL INPUT HEATING	ELEC INPUT HEATING	FUEL INPUT ELECT	TOTAL FUEL INPUT	TOTAL SITE ENERGY	TOTAL SOURCE ENERGY
JAN	564.7	0.0	360.2 105.5E	0.0	0.0	0.0	0.0 0.0E	795.4	33.6 9.8E	0.0	795.4	1155.6	* 1877.0
FEB	463.7	0.0	324.1 94.9E	0.0	0.0	0.0	0.0 0.0E	651.6	28.0 8.2E	0.0	651.6	975.6	* 1624.7
MAR	291.8	0.0	361.8 105.9E	0.0	0.0	0.0	0.0 0.0E	427.8	23.9 7.0E	0.0	427.8	789.6	* 1514.2
APR	133.3	0.0	324.5 95.0E	0.0	0.0	0.0	0.0 0.0E	206.5	16.8 4.9E	0.0	206.5	531.0	* 1181.0
MAY	0.0	0.0	405.6 118.8E	0.0	0.0	0.0	0.0 0.0E	0.0	0.0 0.0E	0.0	0.0	405.6	* 1218.1
JUN	0.0	0.0	452.9 132.7E	0.0	0.0	0.0	0.0 0.0E	0.0	0.0 0.0E	0.0	0.0	452.9	* 1360.2
JUL	0.0	0.0	455.1 133.3E	0.0	0.0	0.0	0.0 0.0E	0.0	0.0 0.0E	0.0	0.0	455.1	* 1366.5
AUG	0.0	0.0	506.1 148.2E	0.0	0.0	0.0	0.0 0.0E	0.0	0.0 0.0E	0.0	0.0	506.1	* 1519.9
SEP	0.0	0.0	429.1 125.7E	0.0	0.0	0.0	0.0 0.0E	0.0	0.0 0.0E	0.0	0.0	429.1	* 1288.5
OCT	102.4	0.0	396.7 116.2E	0.0	0.0	0.0	0.0 0.0E	157.5	11.0 3.2E	0.0	157.5	554.2	* 1348.8
NOV	196.1	0.0	318.6 93.3E	0.0	0.0	0.0	0.0 0.0E	294.4	19.5 5.7E	0.0	294.4	612.9	* 1251.0
DEC	442.4	0.0	352.1 103.1E	0.0	0.0	0.0	0.0 0.0E	631.4	29.4 8.6E	0.0	631.4	983.4	* 1688.6
-----	2194.3	0.0	4686.6 1372.6E	0.0	0.0	0.0	0.0 0.0E	3164.6	162.1 47.5E	0.0	3164.6	7851.2	* 17238.5

NOTE-- ALL ENTRIES ARE IN MBTU EXCEPT
 ENTRIES FOLLOWED BY E ARE IN MWH (THOUSANDS OF KWH)

MO	UTILITY-	ELECTRICITY	NATURAL-GAS
	TOTAL (MBTU)	360.171	795.417
JAN	PEAK (KBTU)	1288.279	3735.097
	DY/HR	31/13	17/10
	TOTAL (MBTU)	324.055	651.590
FEB	PEAK (KBTU)	1288.279	3679.114
	DY/HR	14/11	14/10
	TOTAL (MBTU)	361.755	427.828
MAR	PEAK (KBTU)	1288.279	3521.135
	DY/HR	7/ 8	7/ 8
	TOTAL (MBTU)	324.503	206.486
APR	PEAK (KBTU)	1233.279	2607.424
	DY/HR	28/ 7	4/ 7
	TOTAL (MBTU)	405.618	0.000
MAY	PEAK (KBTU)	1634.223	0.000
	DY/HR	26/16	31/ 1
	TOTAL (MBTU)	452.930	0.000
JUN	PEAK (KBTU)	2195.325	0.000
	DY/HR	29/16	30/ 1
	TOTAL (MBTU)	455.053	0.000
JUL	PEAK (KBTU)	2263.095	0.000
	DY/HR	25/14	31/ 1
	TOTAL (MBTU)	506.116	0.000
AUG	PEAK (KBTU)	2204.245	0.000
	DY/HR	18/17	31/ 1
	TOTAL (MBTU)	429.085	0.000
SEP	PEAK (KBTU)	2150.752	0.000
	DY/HR	2/14	30/ 1
	TOTAL (MBTU)	396.697	157.518
OCT	PEAK (KBTU)	1664.330	2461.328
	DY/HR	18/16	17/ 7
	TOTAL (MBTU)	318.561	294.384
NOV	PEAK (KBTU)	1233.279	2770.824
	DY/HR	30/12	28/ 7
	TOTAL (MBTU)	352.051	631.389
DEC	PEAK (KBTU)	1288.279	3534.924
	DY/HR	12/ 8	12/ 8
	ONE YEAR	4686.594	3164.614
	USE/PEAK	2263.095	3735.097

ENTECH ENGINEERING
READING, PA 19603
REPORT- PS-D PLANT LOADS SATISFIED

EZDOE - ELITE SOFTWARE DEVELOPMENT INC
FT. GEORGE G. MEADE

DOE-2.1D 6/ 7/1996 13:25:46 PDL RUN 1
EMCS FEASIBILITY STUDY
WEATHER FILE- BALTIMORE, MD

HEATING LOADS	MBTU SUPPLIED	PCT OF TOTAL LOAD
-----	-----	-----
HW-BOILER	2194.4	100.0
	-----	-----
LOAD SATISFIED	2194.4	100.0
TOTAL LOAD ON PLANT	2194.4	

ELECTRICAL LOADS	MBTU SUPPLIED	PCT OF TOTAL LOAD
-----	-----	-----
ELECTRICITY	4686.6	100.0
	-----	-----
LOAD SATISFIED	4686.6	100.0
TOTAL LOAD ON PLANT	4686.7	

ENTECH ENGINEERING
READING, PA 19603
REPORT- PS-D PLANT LOADS SATISFIED

EZDOE - ELITE SOFTWARE DEVELOPMENT INC
FT. GEORGE G. MEADE

DOE-2.1D 6/ 7/1996 13:25:46 PDL RUN 1
EMCS FEASIBILITY STUDY
WEATHER FILE- BALTIMORE, MD
----- (CONTINUED) -----

SUMMARY OF LOADS MET

TYPE OF LOAD	TOTAL LOAD (MBTU)	LOAD SATISFIED (MBTU)	TOTAL OVERLOAD (MBTU)	PEAK OVERLOAD (MBTU)	HOURS OVERLOADED
HEATING LOADS	2194.4	2194.4	0.000	0.000	0
ELECTRICAL LOADS	4686.7	4686.6	0.000	0.000	0

ENTECH ENGINEERING
 READING, PA 19603
 REPORT- PS-H EQUIPMENT USE STATISTICS

EZDOE - ELITE SOFTWARE DEVELOPMENT INC
 FT. GEORGE G. MEADE

DOB-2.1D 6/ 7/1996 13:25:46 PDL RUN 1
 EMCS FEASIBILITY STUDY
 WEATHER FILE- BALTIMORE, MD

EQUIPMENT	AVG OPER RATIO	MAX LOAD (MBTU)	MON		---		---		---		---	
			DAY	HR	SIZE (MBTU)	OPER HRS	SIZE (MBTU)	OPER HRS	SIZE (MBTU)	OPER HRS	SIZE (MBTU)	OPER HRS
HW-BOILER	0.185	2.699	1	17	10	2.500	4756					

ENTECH ENGINEERING
READING, PA 19603
REPORT- PS-I EQUIPMENT LIFE CYCLE COSTS

EZDOE - ELITE SOFTWARE DEVELOPMENT INC
FT. GEORGE G. MEADE

DOE-2.1D 6/ 7/1996 13:25:46 PDL RUN 1
EMCS FEASIBILITY STUDY
WEATHER FILE- BALTIMORE, MD

E Q U I P M E N T T O T A L S

HW-BOILER	140.7		
NOMINAL SIZE (MBTU)		2.500	
NUMBER INSTALLED		2	
FIRST COST (K\$)	131.1	131.1	
ANNUAL COST (K\$)	4.2	4.2	
CYCLICAL COST (K\$)	5.4	5.4	
-----TOTAL----- (K\$)		140.7	

EQUIPMENT TOTAL	140.7		

ENERGY TYPE	IN SITE MBTU -	ELECTRICITY	NATURAL-GAS
CATEGORY OF USE			
SPACE HEAT	115.10		3164.60
SPACE COOL	630.99		0.00
HVAC AUX	932.34		0.00
DOM HOT WTR	0.00		0.00
AUX SOLAR	0.00		0.00
LIGHTS	2005.24		0.00
VERT TRANS	0.00		0.00
MISC EQUIP	1002.62		0.00
	-----		-----
TOTAL	4686.28		3164.60

TOTAL SITE ENERGY 7851.21 MBTU 74.7 KBTU/SQFT-YR GROSS-AREA 74.7 KBTU/SQFT-YR NET-AREA
 TOTAL SOURCE ENERGY 17238.47 MBTU 164.0 KBTU/SQFT-YR GROSS-AREA 164.0 KBTU/SQFT-YR NET-AREA

PERCENT OF HOURS ANY SYSTEM ZONE OUTSIDE OF THROTTLING RANGE = 34.6
 PERCENT OF HOURS ANY PLANT LOAD NOT SATISFIED = 0.0

NOTE ELECTRICITY AND/OR FUEL USED TO GENERATE ELECTRICITY IS APPORTIONED BASED
 ON THE YEARLY DEMAND. ALL OTHER ENERGY TYPES ARE APPORTIONED HOURLY.

MMDDHH	HW-BOILE R LOAD BTU/HR	HW-BOILE R ELECTRIC USE BTU/HR	HW-BOILE R FUEL USE BTU/HR
	---- (1)	---- (3)	---- (4)
MONTHLY SUMMARY (JAN)			
MN	17866.	1572.	29196.
MX	2699493.	110000.	3735097.
SM	564660416.	26214558.	795418240.
AV	758952.	35235.	1069111.
MONTHLY SUMMARY (FEB)			
MN	17866.	1572.	29196.
MX	2650377.	110000.	3679114.
SM	463741696.	21291886.	651591616.
AV	690092.	31684.	969630.
MONTHLY SUMMARY (MAR)			
MN	17866.	1572.	29196.
MX	2512227.	110000.	3521135.
SM	291778976.	16532053.	427829856.
AV	392176.	22221.	575040.
MONTHLY SUMMARY (APR)			
MN	17866.	1572.	29196.
MX	2014835.	55000.	2607424.
SM	133274960.	9594370.	206484704.
AV	185104.	13326.	286784.
MONTHLY SUMMARY (MAY)			
MN	0.	0.	0.
MX	0.	0.	0.
SM	0.	0.	0.
AV	0.	0.	0.
MONTHLY SUMMARY (JUN)			
MN	0.	0.	0.
MX	0.	0.	0.
SM	0.	0.	0.
AV	0.	0.	0.
MONTHLY SUMMARY (JUL)			
MN	0.	0.	0.
MX	0.	0.	0.
SM	0.	0.	0.
AV	0.	0.	0.

	HW-BOILE R LOAD BTU/HR ----(1)	HW-BOILE R ELECTRIC USE BTU/HR ----(3)	HW-BOILE R FUEL USE BTU/HR ----(4)
MONTHLY SUMMARY (AUG)			
MN	0.	0.	0.
MX	0.	0.	0.
SM	0.	0.	0.
AV	0.	0.	0.
MONTHLY SUMMARY (SEP)			
MN	0.	0.	0.
MX	0.	0.	0.
SM	0.	0.	0.
AV	0.	0.	0.
MONTHLY SUMMARY (OCT)			
MN	0.	0.	0.
MX	1880969.	55000.	2461328.
SM	102380024.	7140926.	157518256.
AV	137608.	9598.	211718.
MONTHLY SUMMARY (NOV)			
MN	17866.	1572.	29196.
MX	2166124.	55000.	2770824.
SM	196073984.	12338147.	294384704.
AV	272325.	17136.	408868.
MONTHLY SUMMARY (DEC)			
MN	17866.	1572.	29196.
MX	2524258.	110000.	3534924.
SM	442381152.	21982462.	631391168.
AV	594598.	29546.	848644.
YEARLY SUMMARY			
MN	0.	0.	0.
MX	2699493.	110000.	3735097.
SM	2194291200.	115094400.	3164618496.
AV	250490.	13139.	361258.

BLDG. 4554
 W/SETBACK, VENT CONTROL
 FILE: FTM4554N

ENTECH ENGINEERING READING, PA 19603 = HOURLY-REPORT		EZDOE - ELITE SOFTWARE DEVELOPMENT INC FT. GEORGE G. MEADE			DOB-2.1D 6/7/1996 EMCS FEASIBILITY STUDY		13:37:44 SDL RUN 1		PAGE 1- 1
MMDDHH	AC-13	AC-13	AC-13	AC-13	AC-13	AC-14	AC-14	AC-14	
	TOT HTG COIL PWR BTU/HR	SUPPLY ELECTRIC KW	HEATING CAPACITY BTU/HR	COOLING ELECTRIC KW	COOLING CAPACITY BTU/HR	TOT HTG COIL PWR BTU/HR	SUPPLY ELECTRIC KW	HEATING CAPACITY BTU/HR	
	----(5)	----(49)	----(78)	----(47)	----(70)	----(5)	----(49)	----(78)	
MONTHLY SUMMARY (JAN)									
MN	-129279.	0.000	-130764.	0.000	0.	-298883.	0.000	-303525.	
MX	0.	2.836	0.	0.000	148448.	0.	6.583	0.	
SM	-20831084.	938.683	-43282804.	0.000	49136288.	-53257156.	2382.902	-109875904.	
AV	-27999.	1.262	-58176.	0.000	66043.	-71582.	3.203	-147683.	
MONTHLY SUMMARY (FEB)									
MN	-128365.	0.000	-130764.	0.000	0.	-295785.	0.000	-303525.	
MX	0.	2.836	0.	0.000	153870.	0.	6.583	0.	
SM	-22147334.	873.457	-40275240.	0.000	45762376.	-42667468.	2211.754	-101984272.	
AV	-32957.	1.300	-59933.	0.000	68099.	-63493.	3.291	-151762.	
MONTHLY SUMMARY (MAR)									
MN	-128495.	0.000	-130764.	0.000	0.	-278575.	0.000	-303525.	
MX	0.	2.836	0.	0.000	159147.	0.	6.583	0.	
SM	-23136094.	981.222	-45244260.	0.000	51396052.	-24414248.	2099.850	-96824352.	
AV	-31097.	1.319	-60812.	0.000	69081.	-32815.	2.822	-130140.	
MONTHLY SUMMARY (APR)									
MN	-123595.	0.000	-130764.	0.000	0.	-222603.	0.000	-303525.	
MX	0.	2.836	0.	0.000	162812.	0.	6.583	0.	
SM	-17228022.	896.145	-41321352.	0.000	47123388.	-8322806.	1862.876	-85897472.	
AV	-23928.	1.245	-57391.	0.000	65449.	-11559.	2.587	-119302.	
MONTHLY SUMMARY (MAY)									
MN	0.	2.836	0.	0.000	136253.	0.	0.000	0.	
MX	0.	2.836	0.	1.414	176117.	0.	6.583	0.	
SM	0.	2109.910	0.	4.636	112254272.	0.	3455.865	0.	
AV	0.	2.836	0.	0.006	150879.	0.	4.645	0.	
MONTHLY SUMMARY (JUN)									
MN	0.	2.836	0.	0.000	134205.	0.	0.000	0.	
MX	0.	2.836	0.	10.043	177695.	0.	6.583	0.	
SM	0.	2041.849	0.	725.073	112779592.	0.	1981.363	0.	
AV	0.	2.836	0.	1.007	156638.	0.	2.752	0.	
MONTHLY SUMMARY (JUL)									
MN	0.	0.000	0.	0.000	0.	0.	0.000	0.	
MX	0.	2.836	0.	12.996	185826.	0.	6.583	0.	
SM	0.	2010.653	0.	1685.722	114351168.	0.	1612.737	0.	
AV	0.	2.702	0.	2.266	153698.	0.	2.168	0.	

	AC-13	AC-13	AC-13	AC-13	AC-13	AC-14	AC-14	AC-14
	TOT HTG COIL PWR BTU/HR	SUPPLY ELECTRIC KW	HEATING CAPACITY BTU/HR	COOLING ELECTRIC KW	COOLING CAPACITY BTU/HR	TOT HTG COIL PWR BTU/HR	SUPPLY ELECTRIC KW	HEATING CAPACITY BTU/HR
	----(5)	----(49)	----(78)	----(47)	----(70)	----(5)	----(49)	----(78)
MONTHLY SUMMARY (AUG)								
MN	0.	0.000	0.	0.000	0.	0.	0.000	0.
MK	0.	2.836	0.	14.413	180294.	0.	6.583	0.
SM	0.	1534.222	0.	2442.704	85435968.	0.	1889.207	0.
AV	0.	2.062	0.	3.283	114833.	0.	2.539	0.
MONTHLY SUMMARY (SEP)								
MN	0.	0.000	0.	0.000	0.	0.	0.000	0.
MK	0.	2.836	0.	13.841	178591.	0.	6.583	0.
SM	0.	1491.683	0.	1643.656	81422320.	0.	2231.502	0.
AV	0.	2.072	0.	2.283	113087.	0.	3.099	0.
MONTHLY SUMMARY (OCT)								
MN	-46845.	0.000	-130764.	0.000	0.	-216283.	0.000	-303525.
MK	0.	2.836	0.	9.103	164973.	0.	6.583	0.
SM	-769723.	1335.708	-17260816.	1087.461	70996240.	-10724905.	2744.945	-40065252.
AV	-1035.	1.795	-23200.	1.462	95425.	-14415.	3.689	-53851.
MONTHLY SUMMARY (NOV)								
MN	-106605.	0.000	-130764.	0.000	0.	-254567.	0.000	-303525.
MK	0.	2.836	0.	0.000	183448.	0.	6.583	0.
SM	-1658294.	680.616	-31383310.	0.000	36509448.	-18972028.	1889.207	-87111576.
AV	-2303.	0.945	-43588.	0.000	50708.	-26350.	2.624	-120988.
MONTHLY SUMMARY (DEC)								
MN	-126856.	0.000	-130764.	0.000	0.	-278518.	0.000	-303525.
MK	0.	2.836	0.	0.000	156885.	0.	6.583	0.
SM	-8680823.	743.006	-34260112.	0.000	38938976.	-43382632.	2303.910	-106233624.
AV	-11668.	0.999	-46049.	0.000	52337.	-58310.	3.097	-142787.
YEARLY SUMMARY								
MN	-129279.	0.000	-130764.	0.000	0.	-298883.	0.000	-303525.
MK	0.	2.836	0.	14.413	185826.	0.	6.583	0.
SM	-94451376.	15637.153	-253027888.	7589.252	846106112.	-201741248.	26666.117	-627992448.
AV	-10782.	1.785	-28884.	0.866	96587.	-23030.	3.044	-71689.

MMDDHH	AC-14	AC-14	AC-15	AC-15	AC-15	AC-15	AC-15	AC-15
	COOLING ELECTRIC KW	COOLING CAPACITY BTU/HR	TOT HTG COIL PWR BTU/HR	SUPPLY ELECTRIC KW	HEATING CAPACITY BTU/HR	COOLING ELECTRIC KW	COOLING CAPACITY BTU/HR	TOT HTG COIL PWR BTU/HR
	----(47)	----(70)	----(5)	----(49)	----(78)	----(47)	----(70)	----(5)
MONTHLY SUMMARY (JAN)								
MN	0.000	0.	-298883.	0.000	-303525.	0.000	0.	-298883.
MX	0.000	356316.	0.	6.583	0.	0.000	356316.	0.
SM	0.000	128986456.	-53257156.	2382.902	-109875904.	0.000	128986456.	-53257156.
AV	0.000	173369.	-71582.	3.203	-147683.	0.000	173369.	-71582.
MONTHLY SUMMARY (FEB)								
MN	0.000	0.	-295785.	0.000	-303525.	0.000	0.	-295785.
MX	0.000	363662.	0.	6.583	0.	0.000	363662.	0.
SM	0.000	119754384.	-42667468.	2211.754	-101984272.	0.000	119754384.	-42667468.
AV	0.000	178206.	-63493.	3.291	-151762.	0.000	178206.	-63493.
MONTHLY SUMMARY (MAR)								
MN	0.000	0.	-278575.	0.000	-303525.	0.000	0.	-278575.
MX	0.000	373776.	0.	6.583	0.	0.000	373776.	0.
SM	0.000	113695880.	-24414248.	2099.850	-96824352.	0.000	113695880.	-24414248.
AV	0.000	152817.	-32815.	2.822	-130140.	0.000	152817.	-32815.
MONTHLY SUMMARY (APR)								
MN	0.000	0.	-222603.	0.000	-303525.	0.000	0.	-222603.
MX	0.000	402814.	0.	6.583	0.	0.000	402814.	0.
SM	0.000	101554048.	-8322806.	1862.876	-85897472.	0.000	101554048.	-8322806.
AV	0.000	141047.	-11559.	2.587	-119302.	0.000	141047.	-11559.
MONTHLY SUMMARY (MAY)								
MN	0.000	0.	0.	0.000	0.	0.000	0.	0.
MX	17.386	386883.	0.	6.583	0.	17.386	386883.	0.
SM	1572.968	189062512.	0.	3455.865	0.	1572.968	189062512.	0.
AV	2.114	254116.	0.	4.645	0.	2.114	254116.	0.
MONTHLY SUMMARY (JUN)								
MN	0.000	0.	0.	0.000	0.	0.000	0.	0.
MX	35.261	396724.	0.	6.583	0.	35.261	396724.	0.
SM	4421.482	109938240.	0.	1981.363	0.	4421.482	109938240.	0.
AV	6.141	152692.	0.	2.752	0.	6.141	152692.	0.
MONTHLY SUMMARY (JUL)								
MN	0.000	0.	0.	0.000	0.	0.000	0.	0.
MX	37.344	391112.	0.	6.583	0.	37.344	391112.	0.
SM	5394.274	89851888.	0.	1612.737	0.	5394.274	89851888.	0.
AV	7.250	120769.	0.	2.168	0.	7.250	120769.	0.

	AC-14	AC-14	AC-15	AC-15	AC-15	AC-15	AC-15	AC-16
	COOLING ELECTRIC KW	COOLING CAPACITY BTU/HR	TOT HTG COIL PWR BTU/HR	SUPPLY ELECTRIC KW	HEATING CAPACITY BTU/HR	COOLING ELECTRIC KW	COOLING CAPACITY BTU/HR	TOT HTG COIL PWR BTU/HR
	----(47)	----(70)	----(5)	----(49)	----(78)	----(47)	----(70)	----(5)
MONTHLY SUMMARY (AUG)								
MN	0.000	0.	0.	0.000	0.	0.000	0.	0.
MX	34.768	391491.	0.	6.583	0.	34.768	391491.	0.
SM	5782.822	104888616.	0.	1889.207	0.	5782.822	104888616.	0.
AV	7.773	140979.	0.	2.539	0.	7.773	140979.	0.
MONTHLY SUMMARY (SEP)								
MN	0.000	0.	0.	0.000	0.	0.000	0.	0.
MX	32.921	395630.	0.	6.583	0.	32.921	395630.	0.
SM	3321.669	122786864.	0.	2231.502	0.	3321.669	122786864.	0.
AV	4.613	170537.	0.	3.099	0.	4.613	170537.	0.
MONTHLY SUMMARY (OCT)								
MN	0.000	0.	-216283.	0.000	-303525.	0.000	0.	-216283.
MX	15.757	398919.	0.	6.583	0.	15.757	398919.	0.
SM	1803.469	150793328.	-10724905.	2744.945	-40065252.	1803.469	150793328.	-10724905.
AV	2.424	202679.	-14415.	3.689	-53851.	2.424	202679.	-14415.
MONTHLY SUMMARY (NOV)								
MN	0.000	0.	-254567.	0.000	-303525.	0.000	0.	-254567.
MX	0.000	439027.	0.	6.583	0.	0.000	439027.	0.
SM	0.000	104338728.	-18972028.	1889.207	-87111576.	0.000	104338728.	-18972028.
AV	0.000	144915.	-26350.	2.624	-120988.	0.000	144915.	-26350.
MONTHLY SUMMARY (DEC)								
MN	0.000	0.	-278518.	0.000	-303525.	0.000	0.	-278518.
MX	0.000	367954.	0.	6.583	0.	0.000	367954.	0.
SM	0.000	124755944.	-43382632.	2303.910	-106233624.	0.000	124755944.	-43382632.
AV	0.000	167683.	-58310.	3.097	-142787.	0.000	167683.	-58310.
YEARLY SUMMARY								
MN	0.000	0.	-298883.	0.000	-303525.	0.000	0.	-298883.
MX	37.344	439027.	0.	6.583	0.	37.344	439027.	0.
SM	22296.684	1460406912.	-201741248.	26666.117	-627992448.	22296.684	1460406912.	-201741248.
AV	2.545	166713.	-23030.	3.044	-71689.	2.545	166713.	-23030.

MMDH	AC-16	AC-16	AC-16	AC-16	AC-20	AC-20	AC-20	AC-20
	SUPPLY ELECTRIC KW	HEATING CAPACITY BTU/HR	COOLING ELECTRIC KW	COOLING CAPACITY BTU/HR	TOT HTG COIL PWR BTU/HR	SUPPLY ELECTRIC KW	HEATING CAPACITY BTU/HR	COOLING ELECTRIC KW
	----(49)	----(78)	----(47)	----(70)	----(5)	----(49)	----(78)	----(47)
MONTHLY SUMMARY (JAN)								
MN	0.000	-303525.	0.000	0.	-275791.	0.000	-273299.	0.000
MK	6.583	0.	0.000	356316.	0.	5.927	0.	0.000
SM	2382.902	-109875904.	0.000	128986456.	-61023656.	2625.706	-121071664.	0.000
AV	3.203	-147683.	0.000	173369.	-82021.	3.529	-162731.	0.000
MONTHLY SUMMARY (FEB)								
MN	0.000	-303525.	0.000	0.	-268879.	0.000	-273299.	0.000
MK	6.583	0.	0.000	363662.	0.	5.927	0.	0.000
SM	2211.754	-101984272.	0.000	119754384.	-48346572.	2293.788	-105766896.	0.000
AV	3.291	-151762.	0.000	178206.	-71944.	3.413	-157391.	0.000
MONTHLY SUMMARY (MAR)								
MN	0.000	-303525.	0.000	0.	-242057.	0.000	-273299.	0.000
MK	6.583	0.	0.000	373776.	0.	5.927	0.	0.000
SM	2099.850	-96824352.	0.000	113695880.	-31917186.	2216.736	-102214000.	0.000
AV	2.822	-130140.	0.000	152817.	-42899.	2.979	-137384.	0.000
MONTHLY SUMMARY (APR)								
MN	0.000	-303525.	0.000	0.	-200710.	0.000	-273299.	0.000
MK	6.583	0.	0.000	402814.	0.	5.927	0.	0.000
SM	1862.876	-85897472.	0.000	101554048.	-13444692.	1778.130	-81989824.	0.000
AV	2.587	-119302.	0.000	141047.	-18673.	2.470	-113875.	0.000
MONTHLY SUMMARY (MAY)								
MN	0.000	0.	0.000	0.	0.	0.000	0.	0.000
MK	6.583	0.	17.386	386883.	0.	5.927	0.	12.785
SM	3455.865	0.	1572.968	189062512.	0.	3319.176	0.	1016.577
AV	4.645	0.	2.114	254116.	0.	4.461	0.	1.366
MONTHLY SUMMARY (JUN)								
MN	0.000	0.	0.000	0.	0.	0.000	0.	0.000
MK	6.583	0.	35.261	396724.	0.	5.927	0.	29.188
SM	1981.363	0.	4421.482	109938240.	0.	1926.308	0.	3327.802
AV	2.752	0.	6.141	152692.	0.	2.675	0.	4.622
MONTHLY SUMMARY (JUL)								
MN	0.000	0.	0.000	0.	0.	0.000	0.	0.000
MK	6.583	0.	37.344	391112.	0.	5.927	0.	31.875
SM	1612.737	0.	5394.274	89851888.	0.	1458.067	0.	4082.854
AV	2.168	0.	7.250	120769.	0.	1.960	0.	5.488

	AC-16	AC-16	AC-16	AC-16	AC-20	AC-20	AC-20	AC-20
	SUPPLY ELECTRIC KW	HEATING CAPACITY BTU/HR	COOLING ELECTRIC KW	COOLING CAPACITY BTU/HR	TOT HTG COIL PWR BTU/HR	SUPPLY ELECTRIC KW	HEATING CAPACITY BTU/HR	COOLING ELECTRIC KW
	----(49)	----(78)	----(47)	----(70)	----(5)	----(49)	----(78)	----(47)
MONTHLY SUMMARY (AUG)								
MN	0.000	0.	0.000	0.	0.	0.000	0.	0.000
MX	6.583	0.	34.768	391491.	0.	5.927	0.	28.291
SM	1889.207	0.	5782.822	104888616.	0.	1849.255	0.	4372.650
AV	2.539	0.	7.773	140979.	0.	2.486	0.	5.877
MONTHLY SUMMARY (SEP)								
MN	0.000	0.	0.000	0.	0.	0.000	0.	0.000
MX	6.583	0.	32.921	395630.	0.	5.927	0.	26.309
SM	2231.502	0.	3321.669	122786864.	0.	2418.257	0.	2355.727
AV	3.099	0.	4.613	170537.	0.	3.359	0.	3.272
MONTHLY SUMMARY (OCT)								
MN	0.000	-303525.	0.000	0.	-197738.	0.000	-273299.	0.000
MX	6.583	0.	15.757	398919.	0.	5.927	0.	11.894
SM	2744.945	-40065252.	1803.469	150793328.	-13162082.	2767.956	-39355124.	1329.710
AV	3.689	-53851.	2.424	202679.	-17691.	3.720	-52897.	1.787
MONTHLY SUMMARY (NOV)								
MN	0.000	-303525.	0.000	0.	-216360.	0.000	-273299.	0.000
MX	6.583	0.	0.000	439027.	0.	5.927	0.	0.000
SM	1889.207	-87111576.	0.000	104338728.	-25923632.	2104.121	-97021320.	0.000
AV	2.624	-120988.	0.000	144915.	-36005.	2.922	-134752.	0.000
MONTHLY SUMMARY (DEC)								
MN	0.000	-303525.	0.000	0.	-257154.	0.000	-273299.	0.000
MX	6.583	0.	0.000	367954.	0.	5.927	0.	0.000
SM	2303.910	-106233624.	0.000	124755944.	-52471292.	2554.581	-117792072.	0.000
AV	3.097	-142787.	0.000	167683.	-70526.	3.434	-158323.	0.000
YEARLY SUMMARY								
MN	0.000	-303525.	0.000	0.	-275791.	0.000	-273299.	0.000
MX	6.583	0.	37.344	439027.	0.	5.927	0.	31.875
SM	26666.117	-627992448.	22296.684	1460406912.	-246289104.	27312.080	-665210880.	16485.318
AV	3.044	-71689.	2.545	166713.	-28115.	3.118	-75937.	1.882

MDDHH	AC-20	AC-22	AC-22	AC-22	AC-22	AC-22	AC-17	AC-17
	COOLING CAPACITY BTU/HR	TOT HTG COIL PWR BTU/HR	SUPPLY ELECTRIC KW	HEATING CAPACITY BTU/HR	COOLING ELECTRIC KW	COOLING CAPACITY BTU/HR	TOT HTG COIL PWR BTU/HR	SUPPLY ELECTRIC KW
	---- (70)	---- (5)	---- (49)	---- (78)	---- (47)	---- (70)	---- (5)	---- (49)
MONTHLY SUMMARY (JAN)								
MN	0.	-129279.	0.000	-130764.	0.000	0.	-300848.	0.000
MX	310378.	0.	2.836	0.	0.000	148448.	0.	6.631
SM	137497568.	-20831084.	938.683	-43282804.	0.000	49136288.	-52309828.	2380.493
AV	184809.	-27999.	1.262	-58176.	0.000	66043.	-70309.	3.200
MONTHLY SUMMARY (FEB)								
MN	0.	-128365.	0.000	-130764.	0.000	0.	-298031.	0.000
MX	315348.	0.	2.836	0.	0.000	153870.	0.	6.631
SM	120132112.	-22147334.	873.457	-40275240.	0.000	45762376.	-41898372.	2221.352
AV	178768.	-32957.	1.300	-59933.	0.000	68099.	-62349.	3.306
MONTHLY SUMMARY (MAR)								
MN	0.	-128495.	0.000	-130764.	0.000	0.	-276975.	0.000
MX	324965.	0.	2.836	0.	0.000	159147.	0.	6.631
SM	116091400.	-23136094.	981.222	-45244260.	0.000	51396052.	-23784736.	2108.626
AV	156037.	-31097.	1.319	-60812.	0.000	69081.	-31969.	2.834
MONTHLY SUMMARY (APR)								
MN	0.	-123595.	0.000	-130764.	0.000	0.	-224144.	0.000
MX	347670.	0.	2.836	0.	0.000	162812.	0.	6.631
SM	93581104.	-17228022.	896.145	-41321352.	0.000	47123388.	-8162343.	1869.914
AV	129974.	-23928.	1.245	-57391.	0.000	65449.	-11337.	2.597
MONTHLY SUMMARY (MAY)								
MN	0.	0.	2.836	0.	0.000	136253.	0.	0.000
MX	353316.	0.	2.836	0.	1.414	176117.	0.	6.631
SM	175921552.	0.	2109.910	0.	4.636	112254272.	0.	3421.544
AV	236454.	0.	2.836	0.	0.006	150879.	0.	4.599
MONTHLY SUMMARY (JUN)								
MN	0.	0.	2.836	0.	0.000	134205.	0.	0.000
MX	354747.	0.	2.836	0.	10.043	177695.	0.	6.631
SM	103838592.	0.	2041.849	0.	725.073	112779592.	0.	1936.223
AV	144220.	0.	2.836	0.	1.007	156638.	0.	2.689
MONTHLY SUMMARY (JUL)								
MN	0.	0.	0.000	0.	0.000	0.	0.	0.000
MX	345413.	0.	2.836	0.	12.996	185826.	0.	6.631
SM	78766832.	0.	2010.653	0.	1685.722	114351168.	0.	1624.570
AV	105869.	0.	2.702	0.	2.266	153698.	0.	2.184

	AC-20	AC-22	AC-22	AC-22	AC-22	AC-22	AC-17	AC-17
	COOLING CAPACITY BTU/HR	TOT HTG COIL PWR BTU/HR	SUPPLY ELECTRIC KW	HEATING CAPACITY BTU/HR	COOLING ELECTRIC KW	COOLING CAPACITY BTU/HR	TOT HTG COIL PWR BTU/HR	SUPPLY ELECTRIC KW
	----(70)	----(5)	----(49)	----(78)	----(47)	----(70)	----(5)	----(49)
MONTHLY SUMMARY (AUG)								
MN	0.	0.	0.000	0.	0.000	0.	0.	0.000
MX	344889.	0.	2.836	0.	14.413	180294.	0.	6.631
SM	99801056.	0.	1534.222	0.	2442.704	85435968.	0.	1889.806
AV	134141.	0.	2.062	0.	3.283	114833.	0.	2.540
MONTHLY SUMMARY (SEP)								
MN	0.	0.	0.000	0.	0.000	0.	0.	0.000
MX	348160.	0.	2.836	0.	13.841	178591.	0.	6.631
SM	128617592.	0.	1491.683	0.	1643.656	81422320.	0.	2188.197
AV	178636.	0.	2.072	0.	2.283	113087.	0.	3.039
MONTHLY SUMMARY (OCT)								
MN	0.	-46845.	0.000	-130764.	0.000	0.	-217158.	0.000
MX	344761.	0.	2.836	0.	9.103	164973.	0.	6.631
SM	146853616.	-769723.	1335.708	-17260816.	1087.461	70996240.	-10588887.	2751.823
AV	197384.	-1035.	1.795	-23200.	1.462	95425.	-14232.	3.699
MONTHLY SUMMARY (NOV)								
MN	0.	-106605.	0.000	-130764.	0.000	0.	-256010.	0.000
MX	379337.	0.	2.836	0.	0.000	183448.	0.	6.631
SM	111854640.	-1658294.	680.616	-31383310.	0.000	36509448.	-18366136.	1896.437
AV	155354.	-2303.	0.945	-43588.	0.000	50708.	-25509.	2.634
MONTHLY SUMMARY (DEC)								
MN	0.	-126856.	0.000	-130764.	0.000	0.	-276634.	0.000
MX	318638.	0.	2.836	0.	0.000	156885.	0.	6.631
SM	133799536.	-8680823.	743.006	-34260112.	0.000	38938976.	-42299584.	2307.553
AV	179838.	-11668.	0.999	-46049.	0.000	52337.	-56854.	3.102
YEARLY SUMMARY								
MN	0.	-129279.	0.000	-130764.	0.000	0.	-300848.	0.000
MX	379337.	0.	2.836	0.	14.413	185826.	0.	6.631
SM	144675584.	-94451376.	15637.153	-253027888.	7589.252	846106112.	-197409888.	26596.539
AV	165155.	-10782.	1.785	-28884.	0.866	96587.	-22535.	3.036

MMDH	AC-17	AC-17	AC-17	AC-18	AC-18	AC-18	AC-18	AC-18
	HEATING CAPACITY BTU/HR	COOLING ELECTRIC KW	COOLING CAPACITY BTU/HR	TOT HTG COIL PWR BTU/HR	SUPPLY ELECTRIC KW	HEATING CAPACITY BTU/HR	COOLING ELECTRIC KW	COOLING CAPACITY BTU/HR
	----(78)	----(47)	----(70)	----(5)	----(49)	----(78)	----(47)	----(70)
MONTHLY SUMMARY (JAN)								
MN	-305752.	0.000	0.	-300848.	0.000	-305752.	0.000	0.
MX	0.	0.000	361511.	0.	6.631	0.	0.000	361511.
SM	-109764896.	0.000	129782576.	-52309828.	2380.493	-109764896.	0.000	129782576.
AV	-147533.	0.000	174439.	-70309.	3.200	-147533.	0.000	174439.
MONTHLY SUMMARY (FEB)								
MN	-305752.	0.000	0.	-298031.	0.000	-305752.	0.000	0.
MX	0.	0.000	371999.	0.	6.631	0.	0.000	371999.
SM	-102426848.	0.000	121174336.	-41898372.	2221.352	-102426848.	0.000	121174336.
AV	-152421.	0.000	180319.	-62349.	3.306	-152421.	0.000	180319.
MONTHLY SUMMARY (MAR)								
MN	-305752.	0.000	0.	-276975.	0.000	-305752.	0.000	0.
MX	0.	0.000	381525.	0.	6.631	0.	0.000	381525.
SM	-97229072.	0.000	115018672.	-23784736.	2108.626	-97229072.	0.000	115018672.
AV	-130684.	0.000	154595.	-31969.	2.834	-130684.	0.000	154595.
MONTHLY SUMMARY (APR)								
MN	-305752.	0.000	0.	-224144.	0.000	-305752.	0.000	0.
MX	0.	0.000	411846.	0.	6.631	0.	0.000	411846.
SM	-86222000.	0.000	102817960.	-8162343.	1869.914	-86222000.	0.000	102817960.
AV	-119753.	0.000	142803.	-11337.	2.597	-119753.	0.000	142803.
MONTHLY SUMMARY (MAY)								
MN	0.	0.000	0.	0.	0.000	0.	0.000	0.
MX	0.	18.081	394094.	0.	6.631	0.	18.081	394094.
SM	0.	1586.004	188652160.	0.	3421.544	0.	1586.004	188652160.
AV	0.	2.132	253565.	0.	4.599	0.	2.132	253565.
MONTHLY SUMMARY (JUN)								
MN	0.	0.000	0.	0.	0.000	0.	0.000	0.
MX	0.	35.969	405079.	0.	6.631	0.	35.969	405079.
SM	0.	4460.851	108439200.	0.	1936.223	0.	4460.851	108439200.
AV	0.	6.196	150610.	0.	2.689	0.	6.196	150610.
MONTHLY SUMMARY (JUL)								
MN	0.	0.000	0.	0.	0.000	0.	0.000	0.
MX	0.	37.769	397788.	0.	6.631	0.	37.769	397788.
SM	0.	5497.662	91359152.	0.	1624.570	0.	5497.662	91359152.
AV	0.	7.389	122795.	0.	2.184	0.	7.389	122795.

	AC-17	AC-17	AC-17	AC-18	AC-18	AC-18	AC-18	AC-18
	HEATING CAPACITY BTU/HR	COOLING ELECTRIC KW	COOLING CAPACITY BTU/HR	TOT HTG COIL PWR BTU/HR	SUPPLY ELECTRIC KW	HEATING CAPACITY BTU/HR	COOLING ELECTRIC KW	COOLING CAPACITY BTU/HR
	----(78)	----(47)	----(70)	----(5)	----(49)	----(78)	----(47)	----(70)
MONTHLY SUMMARY (AUG)								
MN	0.	0.000	0.	0.	0.000	0.	0.000	0.
MX	0.	35.331	401068.	0.	6.631	0.	35.331	401068.
SM	0.	5893.333	105913976.	0.	1889.806	0.	5893.333	105913976.
AV	0.	7.921	142358.	0.	2.540	0.	7.921	142358.
MONTHLY SUMMARY (SEP)								
MN	0.	0.000	0.	0.	0.000	0.	0.000	0.
MX	0.	33.682	407390.	0.	6.631	0.	33.682	407390.
SM	0.	3400.188	121613048.	0.	2188.197	0.	3400.188	121613048.
AV	0.	4.722	168907.	0.	3.039	0.	4.722	168907.
MONTHLY SUMMARY (OCT)								
MN	-305752.	0.000	0.	-217158.	0.000	-305752.	0.000	0.
MX	0.	16.441	404626.	0.	6.631	0.	16.441	404626.
SM	-40359224.	1856.082	152450768.	-10588887.	2751.823	-40359224.	1856.082	152450768.
AV	-54246.	2.495	204907.	-14232.	3.699	-54246.	2.495	204907.
MONTHLY SUMMARY (NOV)								
MN	-305752.	0.000	0.	-256010.	0.000	-305752.	0.000	0.
MX	0.	0.000	448637.	0.	6.631	0.	0.000	448637.
SM	-87445008.	0.000	105633584.	-18366136.	1896.437	-87445008.	0.000	105633584.
AV	-121451.	0.000	146713.	-25509.	2.634	-121451.	0.000	146713.
MONTHLY SUMMARY (DEC)								
MN	-305752.	0.000	0.	-276634.	0.000	-305752.	0.000	0.
MX	0.	0.000	376377.	0.	6.631	0.	0.000	376377.
SM	-106401632.	0.000	125873928.	-42299584.	2307.553	-106401632.	0.000	125873928.
AV	-143013.	0.000	169185.	-56854.	3.102	-143013.	0.000	169185.
YEARLY SUMMARY								
MN	-305752.	0.000	0.	-300848.	0.000	-305752.	0.000	0.
MX	0.	37.769	448637.	0.	6.631	0.	37.769	448637.
SM	-629848704.	22694.121	1468729344.	-197409888.	26596.539	-629848704.	22694.121	1468729344.
AV	-71901.	2.591	167663.	-22535.	3.036	-71901.	2.591	167663.

MMDDHH	AC-19	AC-19	AC-19	AC-19	AC-19	AC-13	AC-13	AC-13
	TOT HTG COIL PWR BTU/HR	SUPPLY ELECTRIC KW	HEATING CAPACITY BTU/HR	COOLING ELECTRIC KW	COOLING CAPACITY BTU/HR	TOT HTG COIL PWR BTU/HR	SUPPLY ELECTRIC KW	HEATING CAPACITY BTU/HR
	----(5)	----(49)	----(78)	----(47)	----(70)	----(5)	----(49)	----(78)
MONTHLY SUMMARY (JAN)								
MN	-300848.	0.000	-305752.	0.000	0.	-129279.	0.000	-130764.
MK	0.	6.631	0.	0.000	361511.	0.	2.836	0.
SM	-52309828.	2380.493	-109764896.	0.000	129782576.	-20831084.	938.683	-43282804.
AV	-70309.	3.200	-147533.	0.000	174439.	-27999.	1.262	-58176.
MONTHLY SUMMARY (FEB)								
MN	-298031.	0.000	-305752.	0.000	0.	-128365.	0.000	-130764.
MK	0.	6.631	0.	0.000	371999.	0.	2.836	0.
SM	-41898372.	2221.352	-102426848.	0.000	121174336.	-22147334.	873.457	-40275240.
AV	-62349.	3.306	-152421.	0.000	180319.	-32957.	1.300	-59933.
MONTHLY SUMMARY (MAR)								
MN	-276975.	0.000	-305752.	0.000	0.	-128495.	0.000	-130764.
MK	0.	6.631	0.	0.000	381525.	0.	2.836	0.
SM	-23784736.	2108.626	-97229072.	0.000	115018672.	-23136094.	981.222	-45244260.
AV	-31969.	2.834	-130684.	0.000	154595.	-31097.	1.319	-60812.
MONTHLY SUMMARY (APR)								
MN	-224144.	0.000	-305752.	0.000	0.	-123595.	0.000	-130764.
MK	0.	6.631	0.	0.000	411846.	0.	2.836	0.
SM	-8162343.	1869.914	-86222000.	0.000	102817960.	-17228022.	896.145	-41321352.
AV	-11337.	2.597	-119753.	0.000	142803.	-23928.	1.245	-57391.
MONTHLY SUMMARY (MAY)								
MN	0.	0.000	0.	0.000	0.	0.	2.836	0.
MK	0.	6.631	0.	18.081	394094.	0.	2.836	0.
SM	0.	3421.544	0.	1586.004	188652160.	0.	2109.910	0.
AV	0.	4.599	0.	2.132	253565.	0.	2.836	0.
MONTHLY SUMMARY (JUN)								
MN	0.	0.000	0.	0.000	0.	0.	2.836	0.
MK	0.	6.631	0.	35.969	405079.	0.	2.836	0.
SM	0.	1936.223	0.	4460.851	108439200.	0.	2041.849	0.
AV	0.	2.689	0.	6.196	150610.	0.	2.836	0.
MONTHLY SUMMARY (JUL)								
MN	0.	0.000	0.	0.000	0.	0.	0.000	0.
MK	0.	6.631	0.	37.769	397788.	0.	2.836	0.
SM	0.	1624.570	0.	5497.662	91359152.	0.	2010.653	0.
AV	0.	2.184	0.	7.389	122795.	0.	2.702	0.

	AC-19	AC-19	AC-19	AC-19	AC-19	AC-13	AC-13	AC-13
	TOT HTG COIL PWR BTU/HR	SUPPLY ELECTRIC KW	HEATING CAPACITY BTU/HR	COOLING ELECTRIC KW	COOLING CAPACITY BTU/HR	TOT HTG COIL PWR BTU/HR	SUPPLY ELECTRIC KW	HEATING CAPACITY BTU/HR
	----(5)	----(49)	----(78)	----(47)	----(70)	----(5)	----(49)	----(78)
MONTHLY SUMMARY (AUG)								
MN	0.	0.000	0.	0.000	0.	0.	0.000	0.
MX	0.	6.631	0.	35.331	401068.	0.	2.836	0.
SM	0.	1889.806	0.	5893.333	105913976.	0.	1534.222	0.
AV	0.	2.540	0.	7.921	142358.	0.	2.062	0.
MONTHLY SUMMARY (SEP)								
MN	0.	0.000	0.	0.000	0.	0.	0.000	0.
MX	0.	6.631	0.	33.682	407390.	0.	2.836	0.
SM	0.	2188.197	0.	3400.188	121613048.	0.	1491.683	0.
AV	0.	3.039	0.	4.722	168907.	0.	2.072	0.
MONTHLY SUMMARY (OCT)								
MN	-217158.	0.000	-305752.	0.000	0.	-46845.	0.000	-130764.
MX	0.	6.631	0.	16.441	404626.	0.	2.836	0.
SM	-10588887.	2751.823	-40359224.	1856.082	152450768.	-769723.	1335.708	-17260816.
AV	-14232.	3.699	-54246.	2.495	204907.	-1035.	1.795	-23200.
MONTHLY SUMMARY (NOV)								
MN	-256010.	0.000	-305752.	0.000	0.	-106605.	0.000	-130764.
MX	0.	6.631	0.	0.000	448637.	0.	2.836	0.
SM	-18366136.	1896.437	-87445008.	0.000	105633584.	-1658294.	680.616	-31383310.
AV	-25509.	2.634	-121451.	0.000	146713.	-2303.	0.945	-43588.
MONTHLY SUMMARY (DEC)								
MN	-276634.	0.000	-305752.	0.000	0.	-126856.	0.000	-130764.
MX	0.	6.631	0.	0.000	376377.	0.	2.836	0.
SM	-42299584.	2307.553	-106401632.	0.000	125873928.	-8680823.	743.006	-34260112.
AV	-56854.	3.102	-143013.	0.000	169185.	-11668.	0.999	-46049.
YEARLY SUMMARY								
MN	-300848.	0.000	-305752.	0.000	0.	-129279.	0.000	-130764.
MX	0.	6.631	0.	37.769	448637.	0.	2.836	0.
SM	-197409888.	26596.539	-629848704.	22694.121	1468729344.	-94451376.	15637.153	-253027888.
AV	-22535.	3.036	-71901.	2.591	167663.	-10782.	1.785	-28884.

MMDDHH	AC-13	AC-13	AC-24	AC-24	AC-24	AC-24	AC-24
	COOLING ELECTRIC KW	COOLING CAPACITY BTU/HR	TOT HTG COIL PWR BTU/HR	SUPPLY ELECTRIC KW	HEATING CAPACITY BTU/HR	COOLING ELECTRIC KW	COOLING CAPACITY BTU/HR
	----(47)	----(70)	----(5)	----(49)	----(78)	----(47)	----(70)
MONTHLY SUMMARY (JAN)							
MN	0.000	0.	-85971.	0.000	-87582.	0.000	0.
MK	0.000	148448.	0.	1.198	0.	0.000	110157.
SM	0.000	49136288.	-9448098.	402.427	-29427552.	0.000	32943498.
AV	0.000	66043.	-12699.	0.541	-39553.	0.000	44279.
MONTHLY SUMMARY (FEB)							
MN	0.000	0.	-83039.	0.000	-87582.	0.000	0.
MK	0.000	153870.	0.	1.198	0.	0.000	110157.
SM	0.000	45762376.	-7449394.	376.078	-27500748.	0.000	29935734.
AV	0.000	68099.	-11085.	0.560	-40924.	0.000	44547.
MONTHLY SUMMARY (MAR)							
MN	0.000	0.	-76754.	0.000	-87582.	0.000	0.
MK	0.000	159147.	0.	1.198	0.	0.000	101265.
SM	0.000	51396052.	-3682438.	368.892	-26975256.	0.000	28272224.
AV	0.000	69081.	-4950.	0.496	-36257.	0.000	38000.
MONTHLY SUMMARY (APR)							
MN	0.000	0.	-54515.	0.000	-87582.	0.000	0.
MK	0.000	162812.	0.	1.198	0.	0.000	99360.
SM	0.000	47123388.	-906955.	318.588	-23296812.	0.000	23600920.
AV	0.000	65449.	-1260.	0.442	-32357.	0.000	32779.
MONTHLY SUMMARY (MAY)							
MN	0.000	136253.	0.	0.000	0.	0.000	0.
MK	1.414	176117.	0.	1.198	0.	4.755	96089.
SM	4.636	112254272.	0.	475.487	0.	453.950	34250204.
AV	0.006	150879.	0.	0.639	0.	0.610	46035.
MONTHLY SUMMARY (JUN)							
MN	0.000	134205.	0.	0.000	0.	0.000	0.
MK	10.043	177695.	0.	1.198	0.	8.323	89586.
SM	725.073	112779592.	0.	316.193	0.	1127.509	21828778.
AV	1.007	156638.	0.	0.439	0.	1.566	30318.
MONTHLY SUMMARY (JUL)							
MN	0.000	0.	0.	0.000	0.	0.000	0.
MK	12.996	185826.	0.	1.198	0.	8.496	88057.
SM	1685.722	114351168.	0.	287.448	0.	1306.115	19853546.
AV	2.266	153698.	0.	0.386	0.	1.756	26685.

	AC-13	AC-13	AC-24	AC-24	AC-24	AC-24	AC-24
	COOLING ELECTRIC KW	COOLING CAPACITY BTU/HR	TOT HTG COIL PWR BTU/HR	SUPPLY ELECTRIC KW	HEATING CAPACITY BTU/HR	COOLING ELECTRIC KW	COOLING CAPACITY BTU/HR
	----	----	----	----	----	----	----
	(47)	(70)	(5)	(49)	(78)	(47)	(70)
MONTHLY SUMMARY (AUG)							
MN	0.000	0.	0.	0.000	0.	0.000	0.
MX	14.413	180294.	0.	1.198	0.	8.223	88188.
SM	2442.704	85435968.	0.	330.565	0.	1414.025	22735698.
AV	3.283	114833.	0.	0.444	0.	1.901	30559.
MONTHLY SUMMARY (SEP)							
MN	0.000	0.	0.	0.000	0.	0.000	0.
MX	13.841	178591.	0.	1.198	0.	7.855	91109.
SM	1643.656	81422320.	0.	323.379	0.	862.397	22446536.
AV	2.283	113087.	0.	0.449	0.	1.198	31176.
MONTHLY SUMMARY (OCT)							
MN	0.000	0.	-37515.	0.000	-87582.	0.000	0.
MX	9.103	164973.	0.	1.198	0.	4.204	97481.
SM	1087.461	70996240.	-253071.	432.370	-11560824.	260.739	31290564.
AV	1.462	95425.	-340.	0.581	-15539.	0.350	42057.
MONTHLY SUMMARY (NOV)							
MN	0.000	0.	-68101.	0.000	-87582.	0.000	0.
MX	0.000	183448.	0.	1.198	0.	0.000	100839.
SM	0.000	36509448.	-2759459.	320.984	-23471976.	0.000	24719218.
AV	0.000	50708.	-3833.	0.446	-32600.	0.000	34332.
MONTHLY SUMMARY (DEC)							
MN	0.000	0.	-76968.	0.000	-87582.	0.000	0.
MX	0.000	156885.	0.	1.198	0.	0.000	105645.
SM	0.000	38938976.	-7132195.	390.450	-28551732.	0.000	31126836.
AV	0.000	52337.	-9586.	0.525	-38376.	0.000	41837.
YEARLY SUMMARY							
MN	0.000	0.	-85971.	0.000	-87582.	0.000	0.
MX	14.413	185826.	0.	1.198	0.	8.496	110157.
SM	7589.252	846106112.	-31631612.	4342.862	-170784896.	5424.735	323003776.
AV	0.866	96587.	-3611.	0.496	-19496.	0.619	36873.

ENTECH ENGINEERING
READING, PA 19603
REPORT- PV-A EQUIPMENT SIZES

EZDOS - ELITE SOFTWARE DEVELOPMENT INC
FT. GEORGE G. MEADE

DOE-2.1D 6/ 7/1996 13:37:44 PDL RUN 1
EMCS FEASIBILITY STUDY
WEATHER FILE- BALTIMORE, MD

EQUIPMENT	NUMBER		NUMBER		NUMBER		NUMBER		NUMBER	
	SIZE	INSTD	SIZE	INSTD	SIZE	INSTD	SIZE	INSTD	SIZE	INSTD
	(MBTU/H)	AVAIL	(MBTU/H)	AVAIL	(MBTU/H)	AVAIL	(MBTU/H)	AVAIL	(MBTU/H)	AVAIL
HW-BOILER	2.500	2	2							

S I T E E N E R G Y														* SOURCE
	2	3	4	5	6	7	8	9	10	11	12	13	14	
MONTH	TOTAL HEAT LOAD	TOTAL COOLING LOAD	TOTAL ELECTR LOAD	RCVRED ENERGY	WASTED RCVRABL ENERGY	FUEL INPUT COOLING	ELEC INPUT COOLING	FUEL INPUT HEATING	ELEC INPUT HEATING	FUEL INPUT ELECT	TOTAL FUEL INPUT	TOTAL SITE ENERGY	TOTAL SOURCE ENERGY	
JAN	503.3	0.0	358.2 104.9E	0.0	0.0	0.0	0.0 0.0E	716.8	32.2 9.4E	0.0	716.8	1074.9	* 1792.4	*
FEB	414.4	0.0	322.3 94.4E	0.0	0.0	0.0	0.0 0.0E	586.7	26.5 7.8E	0.0	586.7	909.0	* 1554.6	*
MAR	272.2	0.0	361.0 105.7E	0.0	0.0	0.0	0.0 0.0E	400.8	23.1 6.8E	0.0	400.8	761.8	* 1484.8	*
APR	125.0	0.0	323.8 94.8E	0.0	0.0	0.0	0.0 0.0E	193.2	16.1 4.7E	0.0	193.2	517.0	* 1165.6	*
MAY	0.0	0.0	401.4 117.6E	0.0	0.0	0.0	0.0 0.0E	0.0	0.0 0.0E	0.0	0.0	401.4	* 1205.4	*
JUN	0.0	0.0	450.7 132.0E	0.0	0.0	0.0	0.0 0.0E	0.0	0.0 0.0E	0.0	0.0	450.7	* 1353.6	*
JUL	0.0	0.0	454.4 133.1E	0.0	0.0	0.0	0.0 0.0E	0.0	0.0 0.0E	0.0	0.0	454.4	* 1364.5	*
AUG	0.0	0.0	505.3 148.0E	0.0	0.0	0.0	0.0 0.0E	0.0	0.0 0.0E	0.0	0.0	505.3	* 1517.5	*
SEP	0.0	0.0	422.3 123.7E	0.0	0.0	0.0	0.0 0.0E	0.0	0.0 0.0E	0.0	0.0	422.3	* 1268.0	*
OCT	99.0	0.0	392.8 115.0E	0.0	0.0	0.0	0.0 0.0E	152.8	10.8 3.2E	0.0	152.8	545.6	* 1332.5	*
NOV	183.0	0.0	317.8 93.1E	0.0	0.0	0.0	0.0 0.0E	275.6	18.8 5.5E	0.0	275.6	593.5	* 1230.1	*
DEC	399.8	0.0	351.1 102.8E	0.0	0.0	0.0	0.0 0.0E	576.8	28.5 8.3E	0.0	576.8	927.8	* 1631.0	*
-----	1996.8	0.0	4661.1 1365.1E	0.0	0.0	0.0	0.0 0.0E	2902.7	156.0 45.7E	0.0	2902.7	7563.8	* 16899.9	*

NOTE-- ALL ENTRIES ARE IN MBTU EXCEPT
 ENTRIES FOLLOWED BY E ARE IN MWH (THOUSANDS OF KWH)

ENTTECH ENGINEERING
 READING, PA 19603
 REPORT- PS-B MONTHLY PEAK AND TOTAL ENERGY USE

EZDOE - ELITE SOFTWARE DEVELOPMENT INC
 FT. GEORGE G. MEADE

DOE-2.1D 6/ 7/1996 13:37:44 PDL RUN 1
 EMCS FEASIBILITY STUDY
 WEATHER FILE- BALTIMORE, MD

MO	UTILITY-	ELECTRICITY	NATURAL-GAS
	TOTAL (MBTU)	358.178	716.757
JAN	PEAK (KBTU)	1288.266	3731.038
	DY/HR	31/13	17/10
	TOTAL (MBTU)	322.290	586.737
FEB	PEAK (KBTU)	1288.266	3677.682
	DY/HR	14/11	14/10
	TOTAL (MBTU)	360.973	400.824
MAR	PEAK (KBTU)	1233.266	3111.201
	DY/HR	31/ 7	7/ 8
	TOTAL (MBTU)	323.807	193.185
APR	PEAK (KBTU)	1233.266	2607.544
	DY/HR	28/ 7	4/ 7
	TOTAL (MBTU)	401.393	0.000
MAY	PEAK (KBTU)	1634.481	0.000
	DY/HR	26/16	31/ 1
	TOTAL (MBTU)	450.741	0.000
JUN	PEAK (KBTU)	2192.183	0.000
	DY/HR	29/16	30/ 1
	TOTAL (MBTU)	454.389	0.000
JUL	PEAK (KBTU)	2251.987	0.000
	DY/HR	25/14	31/ 1
	TOTAL (MBTU)	505.314	0.000
AUG	PEAK (KBTU)	2204.291	0.000
	DY/HR	18/17	31/ 1
	TOTAL (MBTU)	422.252	0.000
SEP	PEAK (KBTU)	2150.553	0.000
	DY/HR	2/14	30/ 1
	TOTAL (MBTU)	392.828	152.808
OCT	PEAK (KBTU)	1667.423	2419.355
	DY/HR	18/16	24/ 7
	TOTAL (MBTU)	317.842	275.615
NOV	PEAK (KBTU)	1233.266	2783.710
	DY/HR	30/12	28/ 7
	TOTAL (MBTU)	351.059	576.764
DEC	PEAK (KBTU)	1233.266	3119.746
	DY/HR	30/ 9	12/ 8
	ONE YEAR	4661.068	2902.690
	USE/PEAK	2251.987	3731.038

ENTECH ENGINEERING
READING, PA 19603
REPORT- PS-D PLANT LOADS SATISFIED

EZDOE - ELITE SOFTWARE DEVELOPMENT INC
FT. GEORGE G. MEADE

DOE-2.1D 6/ 7/1996 13:37:44 PDL RUN 1
EMCS FEASIBILITY STUDY
WEATHER FILE- BALTIMORE, MD

HEATING LOADS	MBTU SUPPLIED	PCT OF TOTAL LOAD
-----	-----	-----
HW-BOILER	1996.7	100.0
	-----	-----
LOAD SATISFIED	1996.7	100.0
TOTAL LOAD ON PLANT	1996.7	

ELECTRICAL LOADS	MBTU SUPPLIED	PCT OF TOTAL LOAD
-----	-----	-----
ELECTRICITY	4661.1	100.0
	-----	-----
LOAD SATISFIED	4661.1	100.0
TOTAL LOAD ON PLANT	4661.1	

ENTECH ENGINEERING
READING, PA 19603
REPORT- PS-D PLANT LOADS SATISFIED

EZDOE - ELITE SOFTWARE DEVELOPMENT INC
FT. GEORGE G. MEADE

DOB-2.1D 6/ 7/1996 13:37:44 PDL RUN 1
EMCS FEASIBILITY STUDY
WEATHER FILE- BALTIMORE, MD
----- (CONTINUED) -----

SUMMARY OF LOADS MET

TYPE OF LOAD	TOTAL LOAD (MBTU)	LOAD SATISFIED (MBTU)	TOTAL OVERLOAD (MBTU)	PEAK OVERLOAD (MBTU)	HOURS OVERLOADED
HEATING LOADS	1996.7	1996.7	0.000	0.000	0
ELECTRICAL LOADS	4661.1	4661.1	0.000	0.000	0

ENTECH ENGINEERING
 READING, PA 19603
 REPORT- PS-H EQUIPMENT USE STATISTICS

EZDOE - ELITE SOFTWARE DEVELOPMENT INC
 FT. GEORGE G. MEADE

DOE-2.1D 6/ 7/1996 13:37:44 PDL RUN 1
 EMCS FEASIBILITY STUDY
 WEATHER FILE- BALTIMORE, MD

EQUIPMENT	AVG	MAX	MON		---		---		---		---	
	OPER RATIO	LOAD (MBTU)	DAY HR	---	SIZE (MBTU)	OPER HRS	SIZE (MBTU)	OPER HRS	SIZE (MBTU)	OPER HRS	SIZE (MBTU)	OPER HRS
HW-BOILER	0.168	2.696	1 17 10		2.500	4756						

E Q U I P M E N T T O T A L S

HW-BOILER		140.7		
	NOMINAL SIZE (MBTU)		2.500	
	NUMBER INSTALLED		2	
	FIRST COST (K\$)	131.1	131.1	
	ANNUAL COST (K\$)	4.2	4.2	
	CYCLICAL COST (K\$)	5.4	5.4	
	-----TOTAL----- (K\$)		140.7	

EQUIPMENT TOTAL		140.7		

ENERGY TYPE	ELECTRICITY	NATURAL-GAS
IN SITE MBTU -		
CATEGORY OF USE		
SPACE HEAT	109.01	2902.73
SPACE COOL	642.60	0.00
HVAC AUX	901.29	0.00
DOM HOT WTR	0.00	0.00
AUX SOLAR	0.00	0.00
LIGHTS	2005.25	0.00
VERT TRANS	0.00	0.00
MISC EQUIP	1002.62	0.00
TOTAL	4660.77	2902.73

TOTAL SITE ENERGY 7563.76 MBTU 71.9 KBTU/SQFT-YR GROSS-AREA 71.9 KBTU/SQFT-YR NET-AREA
 TOTAL SOURCE ENERGY 16899.89 MBTU 160.7 KBTU/SQFT-YR GROSS-AREA 160.7 KBTU/SQFT-YR NET-AREA

PERCENT OF HOURS ANY SYSTEM ZONE OUTSIDE OF THROTTLING RANGE = 31.9
 PERCENT OF HOURS ANY PLANT LOAD NOT SATISFIED = 0.0

NOTE ELECTRICITY AND/OR FUEL USED TO GENERATE ELECTRICITY IS APPORTIONED BASED
 ON THE YEARLY DEMAND. ALL OTHER ENERGY TYPES ARE APPORTIONED HOURLY.

MDDHH	HW-BOILE R LOAD BTU/HR	HW-BOILE R ELECTRIC USE BTU/HR	HW-BOILE R FUEL USE BTU/HR
	----(1)	----(3)	----(4)
MONTHLY SUMMARY (JAN)			
MN	17843.	1570.	29157.
MX	2695929.	110000.	3731038.
SM	503289920.	24785244.	716756416.
AV	676465.	33314.	963382.
MONTHLY SUMMARY (FEB)			
MN	17843.	1570.	29157.
MX	2649122.	110000.	3677682.
SM	414422400.	19792960.	586736896.
AV	616700.	29454.	873120.
MONTHLY SUMMARY (MAR)			
MN	17843.	1570.	29157.
MX	2486834.	55000.	3111201.
SM	272175456.	15758766.	400825792.
AV	365827.	21181.	538744.
MONTHLY SUMMARY (APR)			
MN	17843.	1570.	29157.
MX	2014946.	55000.	2607544.
SM	125010952.	8907029.	193185712.
AV	173626.	12371.	268314.
MONTHLY SUMMARY (MAY)			
MN	0.	0.	0.
MX	0.	0.	0.
SM	0.	0.	0.
AV	0.	0.	0.
MONTHLY SUMMARY (JUN)			
MN	0.	0.	0.
MX	0.	0.	0.
SM	0.	0.	0.
AV	0.	0.	0.
MONTHLY SUMMARY (JUL)			
MN	0.	0.	0.
MX	0.	0.	0.
SM	0.	0.	0.
AV	0.	0.	0.

 HW-BOILE HW-BOILE HW-BOILE
 R R R
 LOAD ELECTRIC FUEL
 USE USE
 BTU/HR BTU/HR BTU/HR
 ---- (1) ---- (3) ---- (4)

MONTHLY SUMMARY (AUG)

MN	0.	0.	0.
MX	0.	0.	0.
SM	0.	0.	0.
AV	0.	0.	0.

MONTHLY SUMMARY (SEP)

MN	0.	0.	0.
MX	0.	0.	0.
SM	0.	0.	0.
AV	0.	0.	0.

MONTHLY SUMMARY (OCT)

MN	0.	0.	0.
MX	1842750.	55000.	2419355.
SM	99042800.	6982770.	152808272.
AV	133122.	9385.	205387.

MONTHLY SUMMARY (NOV)

MN	17843.	1570.	29157.
MX	2178127.	55000.	2783710.
SM	182983200.	11696467.	275615200.
AV	254143.	16245.	382799.

MONTHLY SUMMARY (DEC)

MN	17843.	1570.	29157.
MX	2494986.	55000.	3119746.
SM	399842336.	21087148.	576762752.
AV	537423.	28343.	775219.

YEARLY SUMMARY

MN	0.	0.	0.
MX	2695929.	110000.	3731038.
SM	1996766976.	109010384.	2902691328.
AV	227941.	12444.	331357.

ENTECH ENGINEERING READING, PA 19603 = HOURLY-REPORT		EZDOE - ELITE SOFTWARE DEVELOPMENT INC FT. GEORGE G. MEADE			DOE-2.1D 6/7/1996 EMCS FEASIBILITY STUDY		13:56:31 SDL RUN 1	
							PAGE 1- 1	
MMDH	AC-13	AC-13	AC-13	AC-13	AC-13	AC-14	AC-14	AC-14
	TOT HTG COIL PWR BTU/HR	SUPPLY ELECTRIC KW	HEATING CAPACITY BTU/HR	COOLING ELECTRIC KW	COOLING CAPACITY BTU/HR	TOT HTG COIL PWR BTU/HR	SUPPLY ELECTRIC KW	HEATING CAPACITY BTU/HR
	---- (5)	----(49)	----(78)	----(47)	----(70)	---- (5)	----(49)	----(78)
MONTHLY SUMMARY (JAN)								
MN	-119611.	0.000	-150006.	0.000	0.	-268820.	0.000	-348190.
MK	0.	2.836	0.	0.000	148448.	0.	6.583	0.
SM	-15988834.	938.683	-49652092.	0.000	49136288.	-41825524.	2376.319	-125696528.
AV	-21490.	1.262	-66737.	0.000	66043.	-56217.	3.194	-168947.
MONTHLY SUMMARY (FEB)								
MN	-125005.	0.000	-150006.	0.000	0.	-265381.	0.000	-348190.
MK	0.	2.836	0.	0.000	149984.	0.	6.583	0.
SM	-18046092.	873.457	-46201944.	0.000	45725608.	-34529192.	2211.754	-116991792.
AV	-26854.	1.300	-68753.	0.000	68044.	-51383.	3.291	-174095.
MONTHLY SUMMARY (MAR)								
MN	-123862.	0.000	-150006.	0.000	0.	-260751.	0.000	-348190.
MK	0.	2.836	0.	0.000	155128.	0.	6.583	0.
SM	-19362750.	981.222	-51902184.	0.000	51370688.	-19552258.	2099.850	-111072560.
AV	-26025.	1.319	-69761.	0.000	69047.	-26280.	2.822	-149291.
MONTHLY SUMMARY (APR)								
MN	-120998.	0.000	-150006.	0.000	0.	-197074.	0.000	-348190.
MK	0.	2.836	0.	0.000	158808.	0.	6.583	0.
SM	-15289629.	896.145	-47402000.	0.000	46968064.	-6726656.	1862.876	-98537720.
AV	-21236.	1.245	-65836.	0.000	65233.	-9343.	2.587	-136858.
MONTHLY SUMMARY (MAY)								
MN	0.	2.836	0.	0.000	136253.	0.	0.000	0.
MK	0.	2.836	0.	1.499	250712.	0.	6.583	0.
SM	0.	2109.910	0.	6.109	111944448.	0.	3442.700	0.
AV	0.	2.836	0.	0.008	150463.	0.	4.627	0.
MONTHLY SUMMARY (JUN)								
MN	0.	2.836	0.	0.000	134203.	0.	0.000	0.
MK	0.	2.836	0.	7.336	298674.	0.	6.583	0.
SM	0.	2041.849	0.	620.983	112000824.	0.	1974.781	0.
AV	0.	2.836	0.	0.862	155557.	0.	2.743	0.
MONTHLY SUMMARY (JUL)								
MN	0.	0.000	0.	0.000	0.	0.	0.000	0.
MK	0.	2.836	0.	9.372	188579.	0.	6.583	0.
SM	0.	2021.997	0.	1381.498	113684424.	0.	1612.737	0.
AV	0.	2.718	0.	1.857	152802.	0.	2.168	0.

	AC-13	AC-13	AC-13	AC-13	AC-13	AC-14	AC-14	AC-14
	TOT HTG COIL PWR BTU/HR	SUPPLY ELECTRIC KW	HEATING CAPACITY BTU/HR	COOLING ELECTRIC KW	COOLING CAPACITY BTU/HR	TOT HTG COIL PWR BTU/HR	SUPPLY ELECTRIC KW	HEATING CAPACITY BTU/HR
	----(5)	----(49)	----(78)	----(47)	----(70)	----(5)	----(49)	----(78)
MONTHLY SUMMARY (AUG)								
MN	0.	0.000	0.	0.000	0.	0.	0.000	0.
MX	0.	2.836	0.	10.806	180279.	0.	6.583	0.
SM	0.	1568.252	0.	2033.213	86022504.	0.	1889.207	0.
AV	0.	2.108	0.	2.733	115622.	0.	2.539	0.
MONTHLY SUMMARY (SEP)								
MN	0.	0.000	0.	0.000	0.	0.	0.000	0.
MX	0.	2.836	0.	10.914	178582.	0.	6.583	0.
SM	0.	1494.519	0.	1481.095	80932400.	0.	2205.172	0.
AV	0.	2.076	0.	2.057	112406.	0.	3.063	0.
MONTHLY SUMMARY (OCT)								
MN	-32681.	0.000	-150006.	0.000	0.	-177488.	0.000	-348190.
MX	0.	2.836	0.	8.616	164396.	0.	6.583	0.
SM	-584527.	1335.708	-19800834.	1199.998	70978304.	-9175006.	2731.779	-45961052.
AV	-786.	1.795	-26614.	1.613	95401.	-12332.	3.672	-61776.
MONTHLY SUMMARY (NOV)								
MN	-86611.	0.000	-150006.	0.000	0.	-249559.	0.000	-348190.
MX	0.	2.836	0.	0.000	178090.	0.	6.583	0.
SM	-1244808.	680.616	-36001516.	0.000	36316832.	-15192374.	1889.207	-99930480.
AV	-1729.	0.945	-50002.	0.000	50440.	-21101.	2.624	-138792.
MONTHLY SUMMARY (DEC)								
MN	-115214.	0.000	-150006.	0.000	0.	-255710.	0.000	-348190.
MX	0.	2.836	0.	0.000	152869.	0.	6.583	0.
SM	-6373662.	743.006	-39301656.	0.000	38914644.	-34227916.	2303.910	-121866456.
AV	-8567.	0.999	-52825.	0.000	52305.	-46005.	3.097	-163799.
YEARLY SUMMARY								
MN	-125005.	0.000	-150006.	0.000	0.	-268820.	0.000	-348190.
MX	0.	2.836	0.	10.914	298674.	0.	6.583	0.
SM	-76890312.	15685.364	-290262240.	6722.895	843995072.	-161228928.	26600.291	-720056576.
AV	-8777.	1.791	-33135.	0.767	96346.	-18405.	3.037	-82198.

MMDDHH	AC-14	AC-14	AC-15	AC-15	AC-15	AC-15	AC-15	AC-15	AC-16
	COOLING ELECTRIC KW	COOLING CAPACITY BTU/HR	TOT HTG COIL PWR BTU/HR	SUPPLY ELECTRIC KW	HEATING CAPACITY BTU/HR	COOLING ELECTRIC KW	COOLING CAPACITY BTU/HR	TOT HTG COIL PWR BTU/HR	
	----(47)	----(70)	----(5)	----(49)	----(78)	----(47)	----(70)	----(5)	
MONTHLY SUMMARY (JAN)									
MN	0.000	0.	-268820.	0.000	-348190.	0.000	0.	-268820.	
MX	0.000	759731.	0.	6.583	0.	0.000	759731.	0.	
SM	0.000	133999824.	-41825524.	2376.319	-125696528.	0.000	133999824.	-41825524.	
AV	0.000	180107.	-56217.	3.194	-168947.	0.000	180107.	-56217.	
MONTHLY SUMMARY (FEB)									
MN	0.000	0.	-265381.	0.000	-348190.	0.000	0.	-265381.	
MX	0.000	504234.	0.	6.583	0.	0.000	504234.	0.	
SM	0.000	123125216.	-34529192.	2211.754	-116991792.	0.000	123125216.	-34529192.	
AV	0.000	183222.	-51383.	3.291	-174095.	0.000	183222.	-51383.	
MONTHLY SUMMARY (MAR)									
MN	0.000	0.	-260751.	0.000	-348190.	0.000	0.	-260751.	
MX	0.000	590117.	0.	6.583	0.	0.000	590117.	0.	
SM	0.000	120190024.	-19552258.	2099.850	-111072560.	0.000	120190024.	-19552258.	
AV	0.000	161546.	-26280.	2.822	-149291.	0.000	161546.	-26280.	
MONTHLY SUMMARY (APR)									
MN	0.000	0.	-197074.	0.000	-348190.	0.000	0.	-197074.	
MX	0.000	582524.	0.	6.583	0.	0.000	582524.	0.	
SM	0.000	111219224.	-6726656.	1862.876	-98537720.	0.000	111219224.	-6726656.	
AV	0.000	154471.	-9343.	2.587	-136858.	0.000	154471.	-9343.	
MONTHLY SUMMARY (MAY)									
MN	0.000	0.	0.	0.000	0.	0.000	0.	0.	
MX	15.697	532071.	0.	6.583	0.	15.697	532071.	0.	
SM	1577.432	192871936.	0.	3442.700	0.	1577.432	192871936.	0.	
AV	2.120	259236.	0.	4.627	0.	2.120	259236.	0.	
MONTHLY SUMMARY (JUN)									
MN	0.000	0.	0.	0.000	0.	0.000	0.	0.	
MX	26.839	481771.	0.	6.583	0.	26.839	481771.	0.	
SM	3870.654	109389136.	0.	1974.781	0.	3870.654	109389136.	0.	
AV	5.376	151929.	0.	2.743	0.	5.376	151929.	0.	
MONTHLY SUMMARY (JUL)									
MN	0.000	0.	0.	0.000	0.	0.000	0.	0.	
MX	28.882	382151.	0.	6.583	0.	28.882	382151.	0.	
SM	4513.282	87458352.	0.	1612.737	0.	4513.282	87458352.	0.	
AV	6.066	117552.	0.	2.168	0.	6.066	117552.	0.	

	AC-14	AC-14	AC-15	AC-15	AC-15	AC-15	AC-15	AC-15	AC-16
	COOLING ELECTRIC KW	COOLING CAPACITY BTU/HR	TOT HTG COIL PWR BTU/HR	SUPPLY ELECTRIC KW	HEATING CAPACITY BTU/HR	COOLING ELECTRIC KW	COOLING CAPACITY BTU/HR	TOT HTG COIL PWR BTU/HR	
	----(47)	----(70)	----(5)	----(49)	----(78)	----(47)	----(70)	----(5)	
MONTHLY SUMMARY (AUG)									
MN	0.000	0.	0.	0.000	0.	0.000	0.	0.	0.
MX	26.519	499553.	0.	6.583	0.	26.519	499553.	0.	0.
SM	4808.237	102643288.	0.	1889.207	0.	4808.237	102643288.	0.	0.
AV	6.463	137961.	0.	2.539	0.	6.463	137961.	0.	0.
MONTHLY SUMMARY (SEP)									
MN	0.000	0.	0.	0.000	0.	0.000	0.	0.	0.
MX	24.668	552139.	0.	6.583	0.	24.668	552139.	0.	0.
SM	3014.349	124507904.	0.	2205.172	0.	3014.349	124507904.	0.	0.
AV	4.187	172928.	0.	3.063	0.	4.187	172928.	0.	0.
MONTHLY SUMMARY (OCT)									
MN	0.000	0.	-177488.	0.000	-348190.	0.000	0.	-177488.	0.
MX	14.756	508410.	0.	6.583	0.	14.756	508410.	0.	0.
SM	1997.198	153112752.	-9175006.	2731.779	-45961052.	1997.198	153112752.	-9175006.	0.
AV	2.684	205797.	-12332.	3.672	-61776.	2.684	205797.	-12332.	0.
MONTHLY SUMMARY (NOV)									
MN	0.000	0.	-249559.	0.000	-348190.	0.000	0.	-249559.	0.
MX	0.000	519989.	0.	6.583	0.	0.000	519989.	0.	0.
SM	0.000	110952224.	-15192374.	1889.207	-99930480.	0.000	110952224.	-15192374.	0.
AV	0.000	154100.	-21101.	2.624	-138792.	0.000	154100.	-21101.	0.
MONTHLY SUMMARY (DEC)									
MN	0.000	0.	-255710.	0.000	-348190.	0.000	0.	-255710.	0.
MX	0.000	511020.	0.	6.583	0.	0.000	511020.	0.	0.
SM	0.000	129429424.	-34227916.	2303.910	-121866456.	0.000	129429424.	-34227916.	0.
AV	0.000	173964.	-46005.	3.097	-163799.	0.000	173964.	-46005.	0.
YEARLY SUMMARY									
MN	0.000	0.	-268820.	0.000	-348190.	0.000	0.	-268820.	0.
MX	28.882	759731.	0.	6.583	0.	28.882	759731.	0.	0.
SM	19781.152	1498899200.	-161228928.	26600.291	-720056576.	19781.152	1498899200.	-161228928.	0.
AV	2.258	171107.	-18405.	3.037	-82198.	2.258	171107.	-18405.	0.

MMDH	AC-16	AC-16	AC-16	AC-16	AC-20	AC-20	AC-20	AC-20
	SUPPLY ELECTRIC KW	HEATING CAPACITY BTU/HR	COOLING ELECTRIC KW	COOLING CAPACITY BTU/HR	TOT HTG COIL PWR BTU/HR	SUPPLY ELECTRIC KW	HEATING CAPACITY BTU/HR	COOLING ELECTRIC KW
	----	----	----	----	----	----	----	----
	(49)	(78)	(47)	(70)	(5)	(49)	(78)	(47)
MONTHLY SUMMARY (JAN)								
MN	0.000	-348190.	0.000	0.	-222459.	0.000	-313517.	0.000
MX	6.583	0.	0.000	759731.	0.	5.927	0.	0.000
SM	2376.319	-125696528.	0.000	133999824.	-49621060.	2625.706	-138887936.	0.000
AV	3.194	-168947.	0.000	180107.	-66695.	3.529	-186677.	0.000
MONTHLY SUMMARY (FEB)								
MN	0.000	-348190.	0.000	0.	-220355.	0.000	-313517.	0.000
MX	6.583	0.	0.000	504234.	0.	5.927	0.	0.000
SM	2211.754	-116991792.	0.000	123125216.	-40265708.	2293.788	-121331000.	0.000
AV	3.291	-174095.	0.000	183222.	-59919.	3.413	-180552.	0.000
MONTHLY SUMMARY (MAR)								
MN	0.000	-348190.	0.000	0.	-214770.	0.000	-313517.	0.000
MX	6.583	0.	0.000	590117.	0.	5.927	0.	0.000
SM	2099.850	-111072560.	0.000	120190024.	-26293672.	2216.736	-117255272.	0.000
AV	2.822	-149291.	0.000	161546.	-35341.	2.979	-157601.	0.000
MONTHLY SUMMARY (APR)								
MN	0.000	-348190.	0.000	0.	-163219.	0.000	-313517.	0.000
MX	6.583	0.	0.000	582524.	0.	5.927	0.	0.000
SM	1862.876	-98537720.	0.000	111219224.	-11211522.	1778.130	-94055024.	0.000
AV	2.587	-136858.	0.000	154471.	-15572.	2.470	-130632.	0.000
MONTHLY SUMMARY (MAY)								
MN	0.000	0.	0.000	0.	0.	0.000	0.	0.000
MX	6.583	0.	15.697	532071.	0.	5.927	0.	12.236
SM	3442.700	0.	1577.432	192871936.	0.	3307.322	0.	1006.266
AV	4.627	0.	2.120	259236.	0.	4.445	0.	1.353
MONTHLY SUMMARY (JUN)								
MN	0.000	0.	0.000	0.	0.	0.000	0.	0.000
MX	6.583	0.	26.839	481771.	0.	5.927	0.	21.711
SM	1974.781	0.	3870.654	109389136.	0.	1926.308	0.	2833.650
AV	2.743	0.	5.376	151929.	0.	2.675	0.	3.936
MONTHLY SUMMARY (JUL)								
MN	0.000	0.	0.000	0.	0.	0.000	0.	0.000
MX	6.583	0.	28.882	382151.	0.	5.927	0.	23.105
SM	1612.737	0.	4513.282	87458352.	0.	1469.921	0.	3337.763
AV	2.168	0.	6.066	117552.	0.	1.976	0.	4.486

	AC-16	AC-16	AC-16	AC-16	AC-20	AC-20	AC-20	AC-20
	SUPPLY ELECTRIC KW	HEATING CAPACITY BTU/HR	COOLING ELECTRIC KW	COOLING CAPACITY BTU/HR	TOT HTG COIL PWR BTU/HR	SUPPLY ELECTRIC KW	HEATING CAPACITY BTU/HR	COOLING ELECTRIC KW
	----(49)	----(78)	----(47)	----(70)	----(5)	----(49)	----(78)	----(47)
MONTHLY SUMMARY (AUG)								
MN	0.000	0.	0.000	0.	0.	0.000	0.	0.000
MX	6.583	0.	26.519	499553.	0.	5.927	0.	20.713
SM	1889.207	0.	4808.237	102643288.	0.	1849.255	0.	3549.886
AV	2.539	0.	6.463	137961.	0.	2.486	0.	4.771
MONTHLY SUMMARY (SEP)								
MN	0.000	0.	0.000	0.	0.	0.000	0.	0.000
MX	6.583	0.	24.668	552139.	0.	5.927	0.	19.795
SM	2205.172	0.	3014.349	124507904.	0.	2406.403	0.	2081.287
AV	3.063	0.	4.187	172928.	0.	3.342	0.	2.891
MONTHLY SUMMARY (OCT)								
MN	0.000	-348190.	0.000	0.	-161653.	0.000	-313517.	0.000
MX	6.583	0.	14.756	508410.	0.	5.927	0.	11.656
SM	2731.779	-45961052.	1997.198	153112752.	-11517582.	2767.956	-45146416.	1483.324
AV	3.672	-61776.	2.684	205797.	-15481.	3.720	-60681.	1.994
MONTHLY SUMMARY (NOV)								
MN	0.000	-348190.	0.000	0.	-203168.	0.000	-313517.	0.000
MX	6.583	0.	0.000	519989.	0.	5.927	0.	0.000
SM	1889.207	-99930480.	0.000	110952224.	-21649206.	2110.048	-111611976.	0.000
AV	2.624	-138792.	0.000	154100.	-30068.	2.931	-155017.	0.000
MONTHLY SUMMARY (DEC)								
MN	0.000	-348190.	0.000	0.	-213760.	0.000	-313517.	0.000
MX	6.583	0.	0.000	511020.	0.	5.927	0.	0.000
SM	2303.910	-121866456.	0.000	129429424.	-43094036.	2554.581	-135125728.	0.000
AV	3.097	-163799.	0.000	173964.	-57922.	3.434	-181621.	0.000
YEARLY SUMMARY								
MN	0.000	-348190.	0.000	0.	-222459.	0.000	-313517.	0.000
MX	6.583	0.	28.882	759731.	0.	5.927	0.	23.105
SM	26600.291	-720056576.	19781.152	1498899200.	-203652768.	27306.150	-763413376.	14292.176
AV	3.037	-82198.	2.258	171107.	-23248.	3.117	-87148.	1.632

MMDHHR	AC-20	AC-22	AC-22	AC-22	AC-22	AC-22	AC-17	AC-17
	COOLING CAPACITY BTU/HR	TOT HTG COIL PWR BTU/HR	SUPPLY ELECTRIC KW	HEATING CAPACITY BTU/HR	COOLING ELECTRIC KW	COOLING CAPACITY BTU/HR	TOT HTG COIL PWR BTU/HR	SUPPLY ELECTRIC KW
	---- (70)	---- (5)	---- (49)	---- (78)	---- (47)	---- (70)	---- (5)	---- (49)
MONTHLY SUMMARY (JAN)								
MN	0.	-119611.	0.000	-150006.	0.000	0.	-268821.	0.000
MK	734442.	0.	2.836	0.	0.000	148448.	0.	6.631
SM	144613072.	-15988834.	938.683	-49652092.	0.000	49136288.	-41062064.	2373.862
AV	194372.	-21490.	1.262	-66737.	0.000	66043.	-55191.	3.191
MONTHLY SUMMARY (FEB)								
MN	0.	-125005.	0.000	-150006.	0.000	0.	-266641.	0.000
MK	476891.	0.	2.836	0.	0.000	149984.	0.	6.631
SM	124804520.	-18046092.	873.457	-46201944.	0.000	45725608.	-33926560.	2208.090
AV	185721.	-26854.	1.300	-68753.	0.000	68044.	-50486.	3.286
MONTHLY SUMMARY (MAR)								
MN	0.	-123862.	0.000	-150006.	0.000	0.	-261274.	0.000
MK	566465.	0.	2.836	0.	0.000	155128.	0.	6.631
SM	124083152.	-19362750.	981.222	-51902184.	0.000	51370688.	-19062122.	2108.626
AV	166778.	-26025.	1.319	-69761.	0.000	69047.	-25621.	2.834
MONTHLY SUMMARY (APR)								
MN	0.	-120998.	0.000	-150006.	0.000	0.	-191771.	0.000
MK	559300.	0.	2.836	0.	0.000	158808.	0.	6.631
SM	104780440.	-15289629.	896.145	-47402000.	0.000	46968064.	-6610457.	1869.914
AV	145528.	-21236.	1.245	-65836.	0.000	65233.	-9181.	2.597
MONTHLY SUMMARY (MAY)								
MN	0.	0.	2.836	0.	0.000	136253.	0.	0.000
MK	500016.	0.	2.836	0.	1.499	250712.	0.	6.631
SM	180864704.	0.	2109.910	0.	6.109	111944448.	0.	3408.282
AV	243098.	0.	2.836	0.	0.008	150463.	0.	4.581
MONTHLY SUMMARY (JUN)								
MN	0.	0.	2.836	0.	0.000	134203.	0.	0.000
MK	455903.	0.	2.836	0.	7.336	298674.	0.	6.631
SM	104145952.	0.	2041.849	0.	620.983	112000824.	0.	1949.484
AV	144647.	0.	2.836	0.	0.862	155557.	0.	2.708
MONTHLY SUMMARY (JUL)								
MN	0.	0.	0.000	0.	0.000	0.	0.	0.000
MK	329579.	0.	2.836	0.	9.372	188579.	0.	6.631
SM	77059208.	0.	2021.997	0.	1381.498	113684424.	0.	1624.570
AV	103574.	0.	2.718	0.	1.857	152802.	0.	2.184

	AC-20	AC-22	AC-22	AC-22	AC-22	AC-22	AC-17	AC-17
	COOLING CAPACITY BTU/HR	TOT HTG COIL PWR BTU/HR	SUPPLY ELECTRIC KW	HEATING CAPACITY BTU/HR	COOLING ELECTRIC KW	COOLING CAPACITY BTU/HR	TOT HTG COIL PWR BTU/HR	SUPPLY ELECTRIC KW
	---- (70)	---- (5)	---- (49)	---- (78)	---- (47)	---- (70)	---- (5)	---- (49)
MONTHLY SUMMARY (AUG)								
MN	0.	0.	0.000	0.	0.000	0.	0.	0.000
MX	463716.	0.	2.836	0.	10.806	180279.	0.	6.631
SM	97719048.	0.	1568.252	0.	2033.213	86022504.	0.	1896.437
AV	131343.	0.	2.108	0.	2.733	115622.	0.	2.549
MONTHLY SUMMARY (SEP)								
MN	0.	0.	0.000	0.	0.000	0.	0.	0.000
MX	516867.	0.	2.836	0.	10.914	178582.	0.	6.631
SM	132183584.	0.	1494.519	0.	1481.095	80932400.	0.	2174.935
AV	183588.	0.	2.076	0.	2.057	112406.	0.	3.021
MONTHLY SUMMARY (OCT)								
MN	0.	-32681.	0.000	-150006.	0.000	0.	-178354.	0.000
MX	471620.	0.	2.836	0.	8.616	164396.	0.	6.631
SM	150577744.	-584527.	1335.708	-19800834.	1199.998	70978304.	-9046259.	2718.669
AV	202389.	-786.	1.795	-26614.	1.613	95401.	-12159.	3.654
MONTHLY SUMMARY (NOV)								
MN	0.	-86611.	0.000	-150006.	0.000	0.	-249254.	0.000
MX	490087.	0.	2.836	0.	0.000	178090.	0.	6.631
SM	120134184.	-1244808.	680.616	-36001516.	0.000	36316832.	-14699981.	1896.437
AV	166853.	-1729.	0.945	-50002.	0.000	50440.	-20417.	2.634
MONTHLY SUMMARY (DEC)								
MN	0.	-115214.	0.000	-150006.	0.000	0.	-255724.	0.000
MX	482619.	0.	2.836	0.	0.000	152869.	0.	6.631
SM	140148832.	-6373662.	743.006	-39301656.	0.000	38914644.	-33370304.	2307.553
AV	188372.	-8567.	0.999	-52825.	0.000	52305.	-44853.	3.102
YEARLY SUMMARY								
MN	0.	-125005.	0.000	-150006.	0.000	0.	-268821.	0.000
MX	734442.	0.	2.836	0.	10.914	298674.	0.	6.631
SM	1501114368.	-76890312.	15685.364	-290262240.	6722.895	843995072.	-157777744.	26536.861
AV	171360.	-8777.	1.791	-33135.	0.767	96346.	-18011.	3.029

MMDDHH	AC-17	AC-17	AC-17	AC-18	AC-18	AC-18	AC-18	AC-18
	HEATING CAPACITY BTU/HR	COOLING ELECTRIC KW	COOLING CAPACITY BTU/HR	TOT HTG COIL PWR BTU/HR	SUPPLY ELECTRIC KW	HEATING CAPACITY BTU/HR	COOLING ELECTRIC KW	COOLING CAPACITY BTU/HR
	----(78)	----(47)	----(70)	----(5)	----(49)	----(78)	----(47)	----(70)
MONTHLY SUMMARY (JAN)								
MN	-350745.	0.000	0.	-268821.	0.000	-350745.	0.000	0.
MX	0.	0.000	863849.	0.	6.631	0.	0.000	863849.
SM	-125566584.	0.000	138005792.	-41062064.	2373.862	-125566584.	0.000	138005792.
AV	-168772.	0.000	185492.	-55191.	3.191	-168772.	0.000	185492.
MONTHLY SUMMARY (FEB)								
MN	-350745.	0.000	0.	-266641.	0.000	-350745.	0.000	0.
MX	0.	0.000	558862.	0.	6.631	0.	0.000	558862.
SM	-116797968.	0.000	126071768.	-33926560.	2208.090	-116797968.	0.000	126071768.
AV	-173807.	0.000	187607.	-50486.	3.286	-173807.	0.000	187607.
MONTHLY SUMMARY (MAR)								
MN	-350745.	0.000	0.	-261274.	0.000	-350745.	0.000	0.
MX	0.	0.000	663861.	0.	6.631	0.	0.000	663861.
SM	-111536808.	0.000	124704888.	-19062122.	2108.626	-111536808.	0.000	124704888.
AV	-149915.	0.000	167614.	-25621.	2.834	-149915.	0.000	167614.
MONTHLY SUMMARY (APR)								
MN	-350745.	0.000	0.	-191771.	0.000	-350745.	0.000	0.
MX	0.	0.000	655523.	0.	6.631	0.	0.000	655523.
SM	-98910000.	0.000	116572368.	-6610457.	1869.914	-98910000.	0.000	116572368.
AV	-137375.	0.000	161906.	-9181.	2.597	-137375.	0.000	161906.
MONTHLY SUMMARY (MAY)								
MN	0.	0.000	0.	0.	0.000	0.	0.000	0.
MX	0.	16.458	586692.	0.	6.631	0.	16.458	586692.
SM	0.	1649.726	194024352.	0.	3408.282	0.	1649.726	194024352.
AV	0.	2.217	260785.	0.	4.581	0.	2.217	260785.
MONTHLY SUMMARY (JUN)								
MN	0.	0.000	0.	0.	0.000	0.	0.000	0.
MX	0.	27.647	519483.	0.	6.631	0.	27.647	519483.
SM	0.	3976.531	109209336.	0.	1949.484	0.	3976.531	109209336.
AV	0.	5.523	151680.	0.	2.708	0.	5.523	151680.
MONTHLY SUMMARY (JUL)								
MN	0.	0.000	0.	0.	0.000	0.	0.000	0.
MX	0.	29.453	390642.	0.	6.631	0.	29.453	390642.
SM	0.	4635.192	89009160.	0.	1624.570	0.	4635.192	89009160.
AV	0.	6.230	119636.	0.	2.184	0.	6.230	119636.

	AC-17	AC-17	AC-17	AC-18	AC-18	AC-18	AC-18	AC-18
	HEATING CAPACITY BTU/HR	COOLING ELECTRIC KW	COOLING CAPACITY BTU/HR	TOT HTG COIL PWR BTU/HR	SUPPLY ELECTRIC KW	HEATING CAPACITY BTU/HR	COOLING ELECTRIC KW	COOLING CAPACITY BTU/HR
	----(78)	----(47)	----(70)	----(5)	----(49)	----(78)	----(47)	----(70)
MONTHLY SUMMARY (AUG)								
MN	0.	0.000	0.	0.	0.000	0.	0.000	0.
MX	0.	27.348	543738.	0.	6.631	0.	27.348	543738.
SM	0.	4953.790	104255000.	0.	1896.437	0.	4953.790	104255000.
AV	0.	6.658	140128.	0.	2.549	0.	6.658	140128.
MONTHLY SUMMARY (SEP)								
MN	0.	0.000	0.	0.	0.000	0.	0.000	0.
MX	0.	25.513	606297.	0.	6.631	0.	25.513	606297.
SM	0.	3165.691	125128816.	0.	2174.935	0.	3165.691	125128816.
AV	0.	4.397	173790.	0.	3.021	0.	4.397	173790.
MONTHLY SUMMARY (OCT)								
MN	-350745.	0.000	0.	-178354.	0.000	-350745.	0.000	0.
MX	0.	15.677	532074.	0.	6.631	0.	15.677	532074.
SM	-46298300.	2130.073	154408896.	-9046259.	2718.669	-46298300.	2130.073	154408896.
AV	-62229.	2.863	207539.	-12159.	3.654	-62229.	2.863	207539.
MONTHLY SUMMARY (NOV)								
MN	-350745.	0.000	0.	-249254.	0.000	-350745.	0.000	0.
MX	0.	0.000	574770.	0.	6.631	0.	0.000	574770.
SM	-100312968.	0.000	115296472.	-14699981.	1896.437	-100312968.	0.000	115296472.
AV	-139324.	0.000	160134.	-20417.	2.634	-139324.	0.000	160134.
MONTHLY SUMMARY (DEC)								
MN	-350745.	0.000	0.	-255724.	0.000	-350745.	0.000	0.
MX	0.	0.000	566050.	0.	6.631	0.	0.000	566050.
SM	-122059136.	0.000	133535352.	-33370304.	2307.553	-122059136.	0.000	133535352.
AV	-164058.	0.000	179483.	-44853.	3.102	-164058.	0.000	179483.
YEARLY SUMMARY								
MN	-350745.	0.000	0.	-268821.	0.000	-350745.	0.000	0.
MX	0.	29.453	863849.	0.	6.631	0.	29.453	863849.
SM	-721481728.	20511.004	1530222208.	-157777744.	26536.861	-721481728.	20511.004	1530222208.
AV	-82361.	2.341	174683.	-18011.	3.029	-82361.	2.341	174683.

MMDDHH	AC-19	AC-19	AC-19	AC-19	AC-19	AC-13	AC-13	AC-13
	TOT HTG COIL PWR BTU/HR	SUPPLY ELECTRIC KW	HEATING CAPACITY BTU/HR	COOLING ELECTRIC KW	COOLING CAPACITY BTU/HR	TOT HTG COIL PWR BTU/HR	SUPPLY ELECTRIC KW	HEATING CAPACITY BTU/HR
	---- (5)	----(49)	----(78)	----(47)	----(70)	----(5)	----(49)	----(78)
MONTHLY SUMMARY (JAN)								
MN	-268821.	0.000	-350745.	0.000	0.	-119611.	0.000	-150006.
MX	0.	6.631	0.	0.000	863849.	0.	2.836	0.
SM	-41062064.	2373.862	-125566584.	0.000	138005792.	-15988834.	938.683	-49652092.
AV	-55191.	3.191	-168772.	0.000	185492.	-21490.	1.262	-66737.
MONTHLY SUMMARY (FEB)								
MN	-266641.	0.000	-350745.	0.000	0.	-125005.	0.000	-150006.
MX	0.	6.631	0.	0.000	558862.	0.	2.836	0.
SM	-33926560.	2208.090	-116797968.	0.000	126071768.	-18046092.	873.457	-46201944.
AV	-50486.	3.286	-173807.	0.000	187607.	-26854.	1.300	-68753.
MONTHLY SUMMARY (MAR)								
MN	-261274.	0.000	-350745.	0.000	0.	-123862.	0.000	-150006.
MX	0.	6.631	0.	0.000	663861.	0.	2.836	0.
SM	-19062122.	2108.626	-111536808.	0.000	124704888.	-19362750.	981.222	-51902184.
AV	-25621.	2.834	-149915.	0.000	167614.	-26025.	1.319	-69761.
MONTHLY SUMMARY (APR)								
MN	-191771.	0.000	-350745.	0.000	0.	-120998.	0.000	-150006.
MX	0.	6.631	0.	0.000	655523.	0.	2.836	0.
SM	-6610457.	1869.914	-98910000.	0.000	116572368.	-15289629.	896.145	-47402000.
AV	-9181.	2.597	-137375.	0.000	161906.	-21236.	1.245	-65836.
MONTHLY SUMMARY (MAY)								
MN	0.	0.000	0.	0.000	0.	0.	2.836	0.
MX	0.	6.631	0.	16.458	586692.	0.	2.836	0.
SM	0.	3408.282	0.	1649.726	194024352.	0.	2109.910	0.
AV	0.	4.581	0.	2.217	260785.	0.	2.836	0.
MONTHLY SUMMARY (JUN)								
MN	0.	0.000	0.	0.000	0.	0.	2.836	0.
MX	0.	6.631	0.	27.647	519483.	0.	2.836	0.
SM	0.	1949.484	0.	3976.531	109209336.	0.	2041.849	0.
AV	0.	2.708	0.	5.523	151680.	0.	2.836	0.
MONTHLY SUMMARY (JUL)								
MN	0.	0.000	0.	0.000	0.	0.	0.000	0.
MX	0.	6.631	0.	29.453	390642.	0.	2.836	0.
SM	0.	1624.570	0.	4635.192	89009160.	0.	2021.997	0.
AV	0.	2.184	0.	6.230	119636.	0.	2.718	0.

	AC-19	AC-19	AC-19	AC-19	AC-19	AC-13	AC-13	AC-13
	TOT HTG COIL PWR BTU/HR	SUPPLY ELECTRIC KW	HEATING CAPACITY BTU/HR	COOLING ELECTRIC KW	COOLING CAPACITY BTU/HR	TOT HTG COIL PWR BTU/HR	SUPPLY ELECTRIC KW	HEATING CAPACITY BTU/HR
	---- (5)	---- (49)	---- (78)	---- (47)	---- (70)	---- (5)	---- (49)	---- (78)
MONTHLY SUMMARY (AUG)								
MN	0.	0.000	0.	0.000	0.	0.	0.000	0.
MK	0.	6.631	0.	27.348	543738.	0.	2.836	0.
SM	0.	1896.437	0.	4953.790	104255000.	0.	1568.252	0.
AV	0.	2.549	0.	6.658	140128.	0.	2.108	0.
MONTHLY SUMMARY (SEP)								
MN	0.	0.000	0.	0.000	0.	0.	0.000	0.
MK	0.	6.631	0.	25.513	606297.	0.	2.836	0.
SM	0.	2174.935	0.	3165.691	125128816.	0.	1494.519	0.
AV	0.	3.021	0.	4.397	173790.	0.	2.076	0.
MONTHLY SUMMARY (OCT)								
MN	-178354.	0.000	-350745.	0.000	0.	-32681.	0.000	-150006.
MK	0.	6.631	0.	15.677	532074.	0.	2.836	0.
SM	-9046259.	2718.669	-46298300.	2130.073	154408896.	-584527.	1335.708	-19800834.
AV	-12159.	3.654	-62229.	2.863	207539.	-786.	1.795	-26614.
MONTHLY SUMMARY (NOV)								
MN	-249254.	0.000	-350745.	0.000	0.	-86611.	0.000	-150006.
MK	0.	6.631	0.	0.000	574770.	0.	2.836	0.
SM	-14699981.	1896.437	-100312968.	0.000	115296472.	-1244808.	680.616	-36001516.
AV	-20417.	2.634	-139324.	0.000	160134.	-1729.	0.945	-50002.
MONTHLY SUMMARY (DEC)								
MN	-255724.	0.000	-350745.	0.000	0.	-115214.	0.000	-150006.
MK	0.	6.631	0.	0.000	566050.	0.	2.836	0.
SM	-33370304.	2307.553	-122059136.	0.000	133535352.	-6373662.	743.006	-39301656.
AV	-44853.	3.102	-164058.	0.000	179483.	-8567.	0.999	-52825.
YEARLY SUMMARY								
MN	-268821.	0.000	-350745.	0.000	0.	-125005.	0.000	-150006.
MK	0.	6.631	0.	29.453	863849.	0.	2.836	0.
SM	-157777744.	26536.861	-721481728.	20511.004	1530222208.	-76890312.	15685.364	-290262240.
AV	-18011.	3.029	-82361.	2.341	174683.	-8777.	1.791	-33135.

MMDHH	AC-13	AC-13	AC-24	AC-24	AC-24	AC-24	AC-24
	COOLING ELECTRIC KW	COOLING CAPACITY BTU/HR	TOT HTG COLL PWR BTU/HR	SUPPLY ELECTRIC KW	HEATING CAPACITY BTU/HR	COOLING ELECTRIC KW	COOLING CAPACITY BTU/HR
	----(47)	----(70)	----(5)	----(49)	----(78)	----(47)	----(70)
MONTHLY SUMMARY (JAN)							
MN	0.000	0.	-71417.	0.000	-87582.	0.000	0.
MX	0.000	148448.	0.	1.198	0.	0.000	232135.
SM	0.000	49136288.	-5532174.	402.427	-29427552.	0.000	35050364.
AV	0.000	66043.	-7436.	0.541	-39553.	0.000	47111.
MONTHLY SUMMARY (FEB)							
MN	0.000	0.	-69794.	0.000	-87582.	0.000	0.
MX	0.000	149984.	0.	1.198	0.	0.000	143238.
SM	0.000	45725608.	-4619574.	376.078	-27500748.	0.000	31253394.
AV	0.000	68044.	-6874.	0.560	-40924.	0.000	46508.
MONTHLY SUMMARY (MAR)							
MN	0.000	0.	-63954.	0.000	-87582.	0.000	0.
MX	0.000	155128.	0.	1.198	0.	0.000	166186.
SM	0.000	51370688.	-2037954.	368.892	-26975256.	0.000	30579526.
AV	0.000	69047.	-2739.	0.496	-36257.	0.000	41102.
MONTHLY SUMMARY (APR)							
MN	0.000	0.	-45672.	0.000	-87582.	0.000	0.
MX	0.000	158808.	0.	1.198	0.	0.000	160418.
SM	0.000	46968064.	-472638.	318.588	-23296812.	0.000	26866130.
AV	0.000	65233.	-656.	0.442	-32357.	0.000	37314.
MONTHLY SUMMARY (MAY)							
MN	0.000	136253.	0.	0.000	0.	0.000	0.
MX	1.499	250712.	0.	1.198	0.	4.188	126620.
SM	6.109	111944448.	0.	469.499	0.	529.716	34153916.
AV	0.008	150463.	0.	0.631	0.	0.712	45906.
MONTHLY SUMMARY (JUN)							
MN	0.000	134203.	0.	0.000	0.	0.000	0.
MX	7.336	298674.	0.	1.198	0.	6.845	88928.
SM	620.983	112000824.	0.	316.193	0.	1031.940	21482176.
AV	0.862	155557.	0.	0.439	0.	1.433	29836.
MONTHLY SUMMARY (JUL)							
MN	0.000	0.	0.	0.000	0.	0.000	0.
MX	9.372	188579.	0.	1.198	0.	7.122	86015.
SM	1381.498	113684424.	0.	287.448	0.	1124.216	19275902.
AV	1.857	152802.	0.	0.386	0.	1.511	25908.

	AC-13	AC-13	AC-24	AC-24	AC-24	AC-24	AC-24
	COOLING ELECTRIC KW	COOLING CAPACITY BTU/HR	TOT HTG COIL PWR BTU/HR	SUPPLY ELECTRIC KW	HEATING CAPACITY BTU/HR	COOLING ELECTRIC KW	COOLING CAPACITY BTU/HR
	----(47)	----(70)	----(5)	----(49)	----(78)	----(47)	----(70)
MONTHLY SUMMARY (AUG)							
MN	0.000	0.	0.	0.000	0.	0.000	0.
MX	10.806	180279.	0.	1.198	0.	6.755	88039.
SM	2033.213	86022504.	0.	330.565	0.	1212.177	22117790.
AV	2.733	115622.	0.	0.444	0.	1.629	29728.
MONTHLY SUMMARY (SEP)							
MN	0.000	0.	0.	0.000	0.	0.000	0.
MX	10.914	178582.	0.	1.198	0.	6.206	93774.
SM	1481.095	80932400.	0.	323.379	0.	833.476	22336106.
AV	2.057	112406.	0.	0.449	0.	1.158	31022.
MONTHLY SUMMARY (OCT)							
MN	0.000	0.	-23136.	0.000	-87582.	0.000	0.
MX	8.616	164396.	0.	1.198	0.	3.797	143866.
SM	1199.998	70978304.	-102272.	431.172	-11560824.	337.400	32254948.
AV	1.613	95401.	-137.	0.580	-15539.	0.453	43353.
MONTHLY SUMMARY (NOV)							
MN	0.000	0.	-56271.	0.000	-87582.	0.000	0.
MX	0.000	178090.	0.	1.198	0.	0.000	140508.
SM	0.000	36316832.	-1322753.	320.984	-23471976.	0.000	26977250.
AV	0.000	50440.	-1837.	0.446	-32600.	0.000	37468.
MONTHLY SUMMARY (DEC)							
MN	0.000	0.	-60210.	0.000	-87582.	0.000	0.
MX	0.000	152869.	0.	1.198	0.	0.000	142192.
SM	0.000	38914644.	-3965287.	390.450	-28551732.	0.000	32951876.
AV	0.000	52305.	-5330.	0.525	-38376.	0.000	44290.
YEARLY SUMMARY							
MN	0.000	0.	-71417.	0.000	-87582.	0.000	0.
MX	10.914	298674.	0.	1.198	0.	7.122	232135.
SM	6722.895	843995072.	-18052652.	4335.675	-170784896.	5068.925	335299392.
AV	0.767	96346.	-2061.	0.495	-19496.	0.579	38276.

S I T E E N E R G Y													* SOURCE
2	3	4	5	6	7	8	9	10	11	12	13	14	
MONTH	TOTAL HEAT LOAD	TOTAL COOLING LOAD	TOTAL ELECTR LOAD	RCVRED ENERGY	WASTED RCVRABL ENERGY	FUEL INPUT COOLING	ELEC INPUT COOLING	FUEL INPUT HEATING	ELEC INPUT HEATING	FUEL INPUT ELECT	TOTAL FUEL INPUT	TOTAL SITE ENERGY	TOTAL SOURCE ENERGY
JAN	397.2	0.0	355.8 104.2E	0.0	0.0	0.0	0.0 0.0E	587.7	29.9 8.8E	0.0	587.7	943.5	1656.1
FEB	337.4	0.0	321.1 94.0E	0.0	0.0	0.0	0.0 0.0E	497.4	25.4 7.4E	0.0	497.4	818.5	1461.7
MAR	221.3	0.0	359.1 105.2E	0.0	0.0	0.0	0.0 0.0E	337.0	21.3 6.2E	0.0	337.0	696.1	1415.4
APR	105.2	0.0	322.2 94.4E	0.0	0.0	0.0	0.0 0.0E	166.3	14.5 4.2E	0.0	166.3	488.5	1134.0
MAY	0.0	0.0	401.9 117.7E	0.0	0.0	0.0	0.0 0.0E	0.0	0.0 0.0E	0.0	0.0	401.9	1206.9
JUN	0.0	0.0	435.9 127.7E	0.0	0.0	0.0	0.0 0.0E	0.0	0.0 0.0E	0.0	0.0	435.9	1308.9
JUL	0.0	0.0	428.9 125.6E	0.0	0.0	0.0	0.0 0.0E	0.0	0.0 0.0E	0.0	0.0	428.9	1288.1
AUG	0.0	0.0	476.9 139.7E	0.0	0.0	0.0	0.0 0.0E	0.0	0.0 0.0E	0.0	0.0	476.9	1432.2
SEP	0.0	0.0	413.2 121.0E	0.0	0.0	0.0	0.0 0.0E	0.0	0.0 0.0E	0.0	0.0	413.2	1240.7
OCT	85.1	0.0	398.3 116.7E	0.0	0.0	0.0	0.0 0.0E	134.7	10.0 2.9E	0.0	134.7	533.0	1330.9
NOV	148.3	0.0	316.2 92.6E	0.0	0.0	0.0	0.0 0.0E	231.0	17.2 5.0E	0.0	231.0	547.2	1180.5
DEC	317.4	0.0	349.6 102.4E	0.0	0.0	0.0	0.0 0.0E	479.7	27.0 7.9E	0.0	479.7	829.3	1529.6
*****	1611.9	0.0	4579.2 1341.1E	0.0	0.0	0.0	0.0 0.0E	2433.7	145.3 42.6E	0.0	2433.7	7012.9	16185.1

NOTE-- ALL ENTRIES ARE IN MBTU EXCEPT
 ENTRIES FOLLOWED BY E ARE IN MWH (THOUSANDS OF KWH)

ENTECH ENGINEERING
 READING, PA 19603
 REPORT- PS-B MONTHLY PEAK AND TOTAL ENERGY USE

EZDOE - ELITE SOFTWARE DEVELOPMENT INC
 FT. GEORGE G. MEADE

DOE-2.1D 6/ 7/1996 13:56:31 PDL RUN 1
 EMCS FEASIBILITY STUDY
 WEATHER FILE- BALTIMORE, MD

MO	UTILITY-	ELECTRICITY	NATURAL-GAS
	TOTAL (MBTU)	355.776	587.750
JAN	PEAK (KBTU)	1232.077	2923.045
	DY/HR	31/17	17/ 7
	TOTAL (MBTU)	321.125	497.364
FEB	PEAK (KBTU)	1232.077	2991.461
	DY/HR	28/12	14/ 7
	TOTAL (MBTU)	359.115	337.024
MAR	PEAK (KBTU)	1232.077	2920.687
	DY/HR	29/ 7	7/ 7
	TOTAL (MBTU)	322.228	166.319
APR	PEAK (KBTU)	1232.077	2362.769
	DY/HR	27/ 7	4/ 7
	TOTAL (MBTU)	401.907	0.000
MAY	PEAK (KBTU)	1602.711	0.000
	DY/HR	20/16	31/ 1
	TOTAL (MBTU)	435.867	0.000
JUN	PEAK (KBTU)	1942.924	0.000
	DY/HR	29/16	30/ 1
	TOTAL (MBTU)	428.927	0.000
JUL	PEAK (KBTU)	1995.230	0.000
	DY/HR	25/14	31/ 1
	TOTAL (MBTU)	476.939	0.000
AUG	PEAK (KBTU)	1957.228	0.000
	DY/HR	18/16	31/ 1
	TOTAL (MBTU)	413.155	0.000
SEP	PEAK (KBTU)	1911.528	0.000
	DY/HR	1/16	30/ 1
	TOTAL (MBTU)	398.335	134.666
OCT	PEAK (KBTU)	1660.240	2039.359
	DY/HR	18/16	24/ 7
	TOTAL (MBTU)	316.200	230.956
NOV	PEAK (KBTU)	1232.077	2653.531
	DY/HR	30/ 9	25/ 7
	TOTAL (MBTU)	349.618	479.657
DEC	PEAK (KBTU)	1232.077	2869.161
	DY/HR	30/ 8	5/ 7
	ONE YEAR	4579.192	2433.736
	USE/PEAK	1995.230	2991.461

ENTECH ENGINEERING
READING, PA 19603
REPORT- PS-D PLANT LOADS SATISFIED

EZDOE - ELITE SOFTWARE DEVELOPMENT INC
FT. GEORGE G. MEADE

DOE-2.1D 6/7/1996 13:56:31 EDL RUN 1
EMCS FEASIBILITY STUDY
WEATHER FILE- BALTIMORE, MD

HEATING LOADS	MBTU SUPPLIED	PCT OF TOTAL LOAD
-----	-----	-----
HW-BOILER	1611.9	100.0
	-----	-----
LOAD SATISFIED	1611.9	100.0
TOTAL LOAD ON PLANT	1611.9	

ELECTRICAL LOADS	MBTU SUPPLIED	PCT OF TOTAL LOAD
-----	-----	-----
ELECTRICITY	4579.2	100.0
	-----	-----
LOAD SATISFIED	4579.2	100.0
TOTAL LOAD ON PLANT	4579.2	

RNTECH ENGINEERING
READING, PA 19603
REPORT- PS-D PLANT LOADS SATISFIED

EZDOE - ELITE SOFTWARE DEVELOPMENT INC
FT. GEORGE G. MEADE

DOE-2.1D 6/ 7/1996 13:56:31 PDL RUN 1
EMCS FEASIBILITY STUDY
WEATHER FILE- BALTIMORE, MD
(CONTINUED)

SUMMARY OF LOADS MET

TYPE OF LOAD	TOTAL LOAD (MBTU)	LOAD SATISFIED (MBTU)	TOTAL OVERLOAD (MBTU)	PEAK OVERLOAD (MBTU)	HOURS OVERLOADED
HEATING LOADS	1611.9	1611.9	0.000	0.000	0
ELECTRICAL LOADS	4579.2	4579.2	0.000	0.000	0

ENTECH ENGINEERING
READING, PA 19603
REPORT- PS-H EQUIPMENT USE STATISTICS

EZDOE - ELITE SOFTWARE DEVELOPMENT INC
FT. GEORGE G. MEADE

DOB-2.1D 6/ 7/1996 13:56:31 PDL RUN 1
EMCS FEASIBILITY STUDY
WEATHER FILE- BALTIMORE, MD

EQUIPMENT	AVG	MAX	MON	-----		-----		-----		-----	
	OPER RATIO	LOAD (MBTU)	DAY HR	SIZE (MBTU)	OPER HRS	SIZE (MBTU)	OPER HRS	SIZE (MBTU)	OPER HRS	SIZE (MBTU)	OPER HRS
HW-BOILER	0.136	2.373	2 14 7	2.500	4728						

ENTECH ENGINEERING
READING, PA 19603
REPORT- PS-I EQUIPMENT LIFE CYCLE COSTS

EZDOE - ELITE SOFTWARE DEVELOPMENT INC
FT. GEORGE G. MEADE

DOE-2.1D 6/ 7/1996 13:56:31 PDL RUN 1
EMCS FEASIBILITY STUDY
WEATHER FILE- BALTIMORE, MD

E Q U I P M E N T T O T A L S

HW-BOILER	140.6		
NOMINAL SIZE (MBTU)		2.500	
NUMBER INSTALLED		2	
FIRST COST (K\$)	131.1	131.1	
ANNUAL COST (K\$)	4.2	4.2	
CYCLICAL COST (K\$)	5.4	5.4	
-----TOTAL----- (K\$)		140.6	

EQUIPMENT TOTAL	140.6		

ENERGY TYPE IN SITE MBTU -	ELECTRICITY	NATURAL-GAS
CATEGORY OF USE		
SPACE HEAT	104.00	2433.81
SPACE COOL	572.45	0.00
HVAC AUX	894.59	0.00
DOM HOT WTR	0.00	0.00
AUX SOLAR	0.00	0.00
LIGHTS	2005.25	0.00
VERT TRANS	0.00	0.00
MISC EQUIP	1002.63	0.00
TOTAL	4578.92	2433.81

TOTAL SITE ENERGY 7012.93 MBTU 66.7 KBTU/SQFT-YR GROSS-AREA 66.7 KBTU/SQFT-YR NET-AREA
 TOTAL SOURCE ENERGY 16185.07 MBTU 153.9 KBTU/SQFT-YR GROSS-AREA 153.9 KBTU/SQFT-YR NET-AREA

PERCENT OF HOURS ANY SYSTEM ZONE OUTSIDE OF THROTTLING RANGE = 31.3
 PERCENT OF HOURS ANY PLANT LOAD NOT SATISFIED = 0.0

NOTE ELECTRICITY AND/OR FUEL USED TO GENERATE ELECTRICITY IS APPORTIONED BASED
 ON THE YEARLY DEMAND. ALL OTHER ENERGY TYPES ARE APPORTIONED HOURLY.

MMDDHH	HW-BOILE R LOAD BTU/HR	HW-BOILE R ELECTRIC USE BTU/HR	HW-BOILE R FUEL USE BTU/HR
	---- (1)	---- (3)	---- (4)
MONTHLY SUMMARY (JAN)			
MN	15706.	1382.	25666.
MX	2308600.	55000.	2923045.
SM	397186912.	23403708.	587750016.
AV	533853.	31457.	789987.
MONTHLY SUMMARY (FEB)			
MN	15706.	1382.	25666.
MX	2373133.	55000.	2991461.
SM	337396512.	19562634.	497364576.
AV	502078.	29111.	740126.
MONTHLY SUMMARY (MAR)			
MN	15706.	1382.	25666.
MX	2306381.	55000.	2920687.
SM	221322480.	14785482.	337024640.
AV	297476.	19873.	452990.
MONTHLY SUMMARY (APR)			
MN	15706.	1382.	25666.
MX	1791390.	55000.	2362769.
SM	105214032.	8183643.	166319616.
AV	146131.	11366.	230999.
MONTHLY SUMMARY (MAY)			
MN	0.	0.	0.
MX	0.	0.	0.
SM	0.	0.	0.
AV	0.	0.	0.
MONTHLY SUMMARY (JUN)			
MN	0.	0.	0.
MX	0.	0.	0.
SM	0.	0.	0.
AV	0.	0.	0.
MONTHLY SUMMARY (JUL)			
MN	0.	0.	0.
MX	0.	0.	0.
SM	0.	0.	0.
AV	0.	0.	0.

	HW-BOILE R LOAD BTU/HR ----(1)	HW-BOILE R ELECTRIC USE BTU/HR ----(3)	HW-BOILE R FUEL USE BTU/HR ----(4)
MONTHLY SUMMARY (AUG)			
MN	0.	0.	0.
MX	0.	0.	0.
SM	0.	0.	0.
AV	0.	0.	0.
MONTHLY SUMMARY (SEP)			
MN	0.	0.	0.
MX	0.	0.	0.
SM	0.	0.	0.
AV	0.	0.	0.
MONTHLY SUMMARY (OCT)			
MN	0.	0.	0.
MX	1501413.	55000.	2039359.
SM	85072424.	6639077.	134665600.
AV	114345.	8923.	181002.
MONTHLY SUMMARY (NOV)			
MN	15706.	1382.	25666.
MX	2057355.	55000.	2653531.
SM	148266320.	10890215.	230956608.
AV	205925.	15125.	320773.
MONTHLY SUMMARY (DEC)			
MN	15706.	1382.	25666.
MX	2257993.	55000.	2869161.
SM	317430176.	20530498.	479657504.
AV	426653.	27595.	644701.
YEARLY SUMMARY			
MN	0.	0.	0.
MX	2373133.	55000.	2991461.
SM	1611888896.	103995256.	2433738496.
AV	184006.	11872.	277824.

ATTACHMENT SECTION 8.2F

BUILDINGS 4587 TO 7100

FT. MEADE, MARYLAND

Building: 4587

Square feet 11,440

Exterior Wall	
Components	R-Value
Outside Surface	0.17
Brick	0.44
Concrete Block	1.72
Gyp Board	0.56
Inside Surface	0.68
Total R-Value	3.57
Total U-Value	0.28

Exterior Roof	
Components	R-Value
Outside Surface	0.17
Shingles	0.44
Wood Deck	0.93
3" Insulation	11.00
Air Space	1.10
Acoustic Tile	1.89
Inside Surface	0.61
Total R-Value	16.14
Total U-Value	0.06

Calculated Total Area	
No. of Floors	1
Avg. Floor to Floor Height	25
No. of Basement Levels	
Gross Floor Area	11440
Roof Area	11440
Estimated Infiltration (cfm)	4800
Gross Wall Area	11650
Door Area	1500
Gross Window Area	1400
Other	
Net Wall Area	8750

Window and Door	
	U-Value
Window Single Pane W/Storm	
Window Single Pane Wo/Storm	
Window Double Pane	0.55
Skylight	
Glass Block	
Other	
Door Type 1	0.50
Door Type 2	
Door Type 3	

$$U_oA_o = (8750 \times 0.28) + (11440 \times 0.06) + (1500 \times 0.5) + (1400 \times 0.55) = 4656.4$$



**FT. MEADE, MARYLAND
EQUIPMENT SCHEDULE**

BUILDING NO. 4587

EQUIPMENT	SYSTEM NUMBER							
	1	2	3	4	5	6	7	8
Equipment Name	Duct Furn	A/C-1						
COOLING:								
Type of Cooling	1							
Air Side	1							
Location in Building	Office							
Area Sq. Feet	1200							
Supply CFM	1200							
Supply Fan HP	1/2							
O.A. CFM or %	20%							
Return CFM								
Return Fan HP								
Chiller Tonnage	3							
Tower or Condenser Fan HP								
Condenser Pump HP								
Chilled Water Pump HP								
HEATING:								
Type of Heating	4							
Source	4							
MBTUH	200							
Hot Water Pump HP								
Condensate Pump HP								
ADDITIONAL:								
Aux. HP Cooling								
Aux. HP Heating								
Operating Schedule Hrs./Week								
Type of Cooling	(4) Water Cooled Chiller (5) Central Plant Supplied (6) Other			Type of Heating (1) Boiler Hot Water (2) Boiler Steam (3) Steam to Hot Water Converter (4) Furnace				
(1) Air Cooled DX								
(2) Water Cooled DX								
(3) Air Cooled Chiller								
	Air Side			Heating Source				
(1) Single Zone	(4) VAV w/ Reheat			(1) Natural Gas (2) Central Plant Steam (3) Central Plant Hot Water				
(2) Multi-Zone	(5) Constant Volume Reheat			(4) Oil (5) Electric				
(3) VAV	(6) Heating and Ventilating							

EMCS Annual Energy Savings Summary Report

```

=====
Base: FTMEADE
Building: 4587
Case: 1
Description: EXCHANGE VEHICLE MAINTENANCE
-----
Fuel Type: Fuel oil, distillate #2
Heating Value: 138,700 Btu/gal
=====
    
```

Caution

```

=====
The ESA program makes no attempt to exclude incompatible strategies.
It is the user's responsibility to select all appropriate strategies.
=====
    
```

Annual Energy Savings Table for Single Zone DX-A/C

```

=====
Description: OFFICE A/C UNIT
=====
Strategy                MBtu/yr      kWh/yr      kW   mh/yr
=====
Day/Night Setback       20.990       135         0.0   0
Vent/Recirculation       4.861         0          0.0   0
Run Time Recording       0.000         0          0.0   2
Safety Alarm             0.000         0          0.0   2
-----
Subtotals                25.851       135         0.0   4
Heating Value /         138,700 Btu/gal
=====
Totals                   186          135         0.0   4
                        gal/yr      kWh/yr      kW   mh/yr
=====
    
```

Annual Energy Savings Table for Direct Fired Furnace

Description: REPAIR BAY OIL FIRED DUCT HEATERS				
Strategy	MBtu/yr	kWh/yr	kW	mh/yr
Scheduled Start/Stop	194.907	2,132	0.0	0
Day/Night Setback	27.844	0	0.0	0
Run Time Recording	0.000	0	0.0	2
Safety Alarm	0.000	0	0.0	2
Subtotals	222.751	2,132	0.0	4
Heating Value /	138,700 Btu/gal			
Totals	1,606 gal/yr	2,132 kWh/yr	0.0 kW	4 mh/yr

EMCS Annual Energy Savings for Building 4587

Description	Value	Units
Fuel oil, distillate #2	1,792	gal/yr
Electrical Energy	2,267	kWh/yr
Electrical Demand Reduction	0.0	kW
Labor Savings	8	mh/yr

FT. MEADE, MARYLAND

Building: 4675

Square feet 1,710

Exterior Wall	
Components	R-Value
Outside Surface	0.17
Metal Siding	0.00
1" Insulation	6.00
Air Space	1.10
Wallboard	0.56
Inside Surface	0.68
Total R-Value	8.51
Total U-Value	0.12

Exterior Roof	
Components	R-Value
Outside Surface	0.17
Metal Roof	0.00
1" Insulation	6.00
Air Space	1.10
Wallboard	0.56
Inside Surface	0.61
Total R-Value	8.44
Total U-Value	0.12

Calculated Total Area	
No. of Floors	1
Avg. Floor to Floor Height	15
No. of Basement Levels	
Gross Floor Area	1710
Roof Area	1710
Estimated Infiltration (cfm)	300
Gross Wall Area	2400
Door Area	0
Gross Window Area	630
Other	
Net Wall Area	1770

Window and Door	
	U-Value
Window Single Pane W/Storm	0.80
Window Single Pane Wo/Storm	
Window Double Pane	
Skylight	
Glass Block	
Other	
Door Type 1	
Door Type 2	
Door Type 3	

$$UoAo = (1770 \times 0.12) + (1710 \times 0.12) + (630 \times 0.8) = 922$$

**FT. MEADE, MARYLAND
EQUIPMENT SCHEDULE**

BUILDING NO. 4675

Page 1 of 1

EQUIPMENT	SYSTEM NUMBER							
	1	2	3	4	5	6	7	8
Equipment Name	AHU-1							
COOLING:								
Type of Cooling	1							
Air Side	1							
Location in Building								
Area Sq. Feet	1710							
Supply CFM	3000							
Supply Fan HP	2							
O.A. CFM or %	0%							
Return CFM								
Return Fan HP								
Chiller Tonnage								
Tower or Condenser Fan HP								
Condenser Pump HP								
Chilled Water Pump HP								
HEATING:								
Type of Heating								
Source	5							
MBTUH	92							
Hot Water Pump HP								
Condensate Pump HP								
ADDITIONAL:								
Aux. HP Cooling								
Aux. HP Heating								
Operating Schedule Hrs./Week								
Type of Cooling	(1) Air Cooled DX (2) Water Cooled DX (3) Air Cooled Chiller Air Side (4) VAV w/ Reheat (5) Constant Volume Reheat (6) Heating and Ventilating							
Type of Heating	(1) Boiler Hot Water (2) Boiler Steam (3) Steam to Hot Water Converter Heating Source (1) Natural Gas (2) Central Plant Steam (3) Central Plant Hot Water (4) Furnace (5) Electric (6) Oil							

EMCS Annual Energy Savings Summary Report

```

=====
Base: FTMEADE
Building: 4675
Case: 1
Description: RENTAL CAR AGENCY
-----
Fuel Type: Electricity
Heating Value: 3,413 Btu/kWh
=====
    
```

Caution

```

=====
The ESA program makes no attempt to exclude incompatible strategies.
It is the user's responsibility to select all appropriate strategies.
=====
    
```

Annual Energy Savings Table for Single Zone DX-A/C

```

=====
Description: AHU-1 SPLIT-SYSTEM UNIT
=====
Strategy                MBtu/yr      kWh/yr      kW   mh/yr
=====
Scheduled Start/Stop    31.191      2,401        0.0   0
  Duty Cycling          0.000        931          0.0   0
  Demand Limiting       0.000         0            0.3   0
  Day/Night Setback     6.205         46           0.0   0
  Run Time Recording    0.000         0            0.0   2
  Safety Alarm          0.000         0            0.0   2
-----
Subtotals                37.396      3,378        0.3   4
Heating Value /         3,413 Btu/kWh
=====
Totals                  10,957      3,378        0.3   4
                        kWh/yr      kWh/yr      kW   mh/yr
=====
    
```

EMCS Annual Energy Savings for Building 4675

```

=====
Description                Value      Units
=====
Electrical Energy          14,335    kWh/yr
Electrical Demand Reduction 0.3       kW
Labor Savings              4         mh/yr
=====
    
```

FT. MEADE, MARYLAND

Building: 4680

Square feet 4,174

Exterior Wall	
Components	R-Value
Outside Surface	0.17
Brick	0.44
Concrete Block	1.72
Inside surface	0.68
Total R-Value	3.01
Total U-Value	0.33

Exterior Roof	
Components	R-Value
Outside Surface	0.17
Shingles	0.44
Wood Deck	0.93
Inulation	11.00
Air Space	1.10
Gyp Board	0.56
Inside surface	0.61
Total R-Value	14.81
Total U-Value	0.07

Calculated Total Area	
No. of Floors	1
Avg. Floor to Floor Height	12
No. of Basement Levels	
Gross Floor Area	4174
Roof Area	4200
Estimated Infiltration (cfm)	700
Gross Wall Area	4750
Door Area	1150
Gross Window Area	50
Other	
Net Wall Area	3550

Window and Door	
	U-Value
Window Single Pane W/Storm	
Window Single Pane Wo/Storm	1.00
Window Double Pane	
Skylight	
Glass Block	
Other	
Door Type 1	1.00
Door Type 2	
Door Type 3	

$UoAo = (3550 \cdot 0.33) + (4200 \cdot 0.07) + (50 \cdot 1.0) + (1200 \cdot 1.0) = 2666$

**FT. MEADE, MARYLAND
EQUIPMENT SCHEDULE**

BUILDING NO. 4680

EQUIPMENT	SYSTEM NUMBER							
	1	2	3	4	5	6	7	8
Equipment Name	AHU-1	Boiler						
COOLING:								
Type of Cooling	1							
Air Side	1							
Location in Building	Office							
Area Sq. Feet	1800							
Supply CFM	2000							
Supply Fan HP	1 1/2							
O.A. CFM or %	400							
Return CFM								
Return Fan HP								
Chiller Tonnage	7 1/2							
Tower or Condenser Fan HP								
Condenser Pump HP								
Chilled Water Pump HP								
HEATING:								
Type of Heating		1						
Source		4						
MBTUH		245/213						
Hot Water Pump HP		1/25						
Condensate Pump HP								
ADDITIONAL:								
Aux. HP Cooling								
Aux. HP Heating								
Operating Schedule Hrs./Week								
Type of Cooling	(4) Water Cooled Chiller (5) Central Plant Supplied (6) Other							
Air Side	(4) VAV w/ Reheat (5) Constant Volume Reheat (6) Heating and Ventilating							
Type of Heating	(1) Boiler Hot Water (2) Boiler Steam (3) Steam to Hot Water Converter							(4) Furnace (5) Electric
Heating Source	(1) Natural Gas (2) Central Plant Steam (3) Central Plant Hot Water							(4) Oil (5) Electric

EMCS Annual Energy Savings Summary Report

```

=====
Base: FTMEADE
Building: 4680
Case: 1
Description: GAS/SERVICE STATION
-----
Fuel Type: Fuel oil, distillate #2
Heating Value: 138,700 Btu/gal
=====
    
```

Caution

```

=====
The ESA program makes no attempt to exclude incompatible strategies.
It is the user's responsibility to select all appropriate strategies.
=====
    
```

Annual Energy Savings Table for Single Zone DX-A/C

```

=====
Description: SPLIT-SYSTEM OFFICE A/C UNIT
=====
Strategy                MBtu/yr      kWh/yr      kW   mh/yr
=====
Demand Limiting          0.000         0           0.2   0
Day/Night Setback       25.361        200          0.0   0
Vent/Recirculation       6.100         0           0.0   0
Run Time Recording       0.000         0           0.0   2
Safety Alarm             0.000         0           0.0   2
-----
Subtotals                 31.461        200          0.2   4
Heating Value /         138,700 Btu/gal
=====
Totals                    227           200          0.2   4
                        gal/yr        kWh/yr        kW   mh/yr
=====
    
```

Annual Energy Savings Table for Hot Water Boiler

Description: BOILER				
Strategy	MBtu/yr	kWh/yr	kW	mh/yr
Hot Water OA Reset	51.882	0	0.0	0
Run Time Recording	0.000	0	0.0	2
Safety Alarm	0.000	0	0.0	2
Subtotals	51.882	0	0.0	4
Heating Value /	138,700 Btu/gal			
Totals	374 gal/yr	0 kWh/yr	0.0 kW	4 mh/yr

EMCS Annual Energy Savings for Building 4680

Description	Value	Units
Fuel oil, distillate #2	601	gal/yr
Electrical Energy	200	kWh/yr
Electrical Demand Reduction	0.2	kW
Labor Savings	8	mh/yr

FT. MEADE, MARYLAND

Building: 4700

Square feet 36,819

Exterior Wall	
Components	R-Value
Outside Surface	0.17
Vinyl Siding	0.00
1/2" Insulation	3.00
Wood Siding	0.81
Air Space	1.10
1/2" Gyp Board	0.56
Inside Surface	0.68
Total R-Value	6.32
Total U-Value	0.16

Exterior Roof	
Components	R-Value
Outside Surface	0.17
Shingles	0.44
1" Wood	0.93
Air Space	1.10
1/2" Acoustic Tile	1.89
Inside Surface	0.61
Total R-Value	5.14
Total U-Value	0.19

Calculated Total Area	
No. of Floors	2
Avg. Floor to Floor Height	12
No. of Basement Levels	1
Gross Floor Area	36819
Roof Area	33254
Estimated Infiltration (cfm)	5000
Gross Wall Area	19394
Door Area	
Gross Window Area	518
Other	
Net Wall Area	18876

Window and Door	
	U-Value
Window Single Pane W/Storm	
Window Single Pane Wo/Storm	
Window Double Pane	0.50
Skylight	
Glass Block	
Other	
Door Type 1	
Door Type 2	
Door Type 3	

$$UoAo = (18876 * 0.16) + (33254 * 0.19) + (518 * 0.5) = 9597$$

FT. MEADE, MARYLAND EQUIPMENT SCHEDULE

EQUIPMENT	SYSTEM NUMBER								
	1	2	3	4	5	6	7	8	
Equipment Name	Boiler								
COOLING:									
Type of Cooling	1		1	1	1	1			
Air Side	1		1	1	1	1			
Location in Building	Band		Jazz	Choir	Equip	Mezz			
Area Sq. Feet	7160		2400	2000	2100	3300			
Supply CFM	6000		2100	1400	2000	2500			
Supply Fan HP	5		3/4	1 1/2	1	1 1/2			
O.A. CFM or %	15%		15%	15%	15%	15%			
Return CFM									
Return Fan HP									
Chiller Tonnage	20		5	7 1/2	5	2			
Tower or Condenser Fan HP									
Condenser Pump HP									
Chilled Water Pump HP									
HEATING:									
Type of Heating	2								
Source	1	2							
MBTUH	1960/1512	100							
Hot Water Pump HP									
Condensate Pump HP	1/3								
ADDITIONAL:									
Aux. HP Cooling									
Aux. HP Heating									
Operating Schedule Hrs./Week									
Type of Cooling	Type of Heating								
(1) Air Cooled DX	(4) Water Cooled Chiller	(1) Boiler Hot Water							
(2) Water Cooled DX	(5) Central Plant Supplied	(2) Boiler Steam							
(3) Air Cooled Chiller	(6) Other	(3) Steam to Hot Water Converter							
Air Side		Heating Source							
(1) Single Zone	(4) VAV w/ Reheat	(1) Natural Gas							
(2) Multi-Zone	(5) Constant Volume Reheat	(2) Central Plant Steam							
(3) VAV	(6) Heating and Ventilating	(3) Central Plant Hot Water							

EMCS Annual Energy Savings Summary Report

```

=====
Base: FTMEADE
Building: 4700
Case: 1
Description: CHAPEL CENTER FACILITY
=====

```

```

=====
Fuel Type: Natural gas (methane)
Heating Value: 1,031 Btu/cf
=====

```

Caution

```

=====
The ESA program makes no attempt to exclude incompatible strategies.
It is the user's responsibility to select all appropriate strategies.
=====

```

Annual Energy Savings Table for Single Zone DX-A/C

```

=====
Description: AC-1
=====

```

Strategy	MBtu/yr	kWh/yr	kW	mh/yr
Day/Night Setback	183.221	553	0.0	0
Vent/Recirculation	7.692	0	0.0	0
Run Time Recording	0.000	0	0.0	2
Safety Alarm	0.000	0	0.0	2
Subtotals	190.913	553	0.0	4
Heating Value /	1,031 Btu/cf			
Totals	185,172 cf /yr	553 kWh/yr	0.0 kW	4 mh/yr

Annual Energy Savings Table for Single Zone DX-A/C

Description: AC-2				
Strategy	MBtu/yr	kWh/yr	kW	mh/yr
Scheduled Start/Stop	0.000	778	0.0	0
Duty Cycling	0.000	262	0.0	0
Demand Limiting	0.000	0	0.1	0
Vent/Recirculation	0.000	0	0.0	0
Run Time Recording	0.000	0	0.0	2
Safety Alarm	0.000	0	0.0	2
Totals	0.000	1,040	0.1	4
	MBtu/yr	kWh/yr	kW	mh/yr

Annual Energy Savings Table for Single Zone DX-A/C

Description: AC-3				
Strategy	MBtu/yr	kWh/yr	kW	mh/yr
Scheduled Start/Stop	0.000	1,050	0.0	0
Duty Cycling	0.000	524	0.0	0
Demand Limiting	0.000	0	0.2	0
Vent/Recirculation	0.000	0	0.0	0
Run Time Recording	0.000	0	0.0	2
Safety Alarm	0.000	0	0.0	2
Totals	0.000	1,573	0.2	4
	MBtu/yr	kWh/yr	kW	mh/yr

Annual Energy Savings Table for Single Zone DX-A/C

Description: AC-4				
Strategy	MBtu/yr	kWh/yr	kW	mh/yr
Scheduled Start/Stop	0.000	881	0.0	0
Duty Cycling	0.000	349	0.0	0
Demand Limiting	0.000	0	0.1	0
Vent/Recirculation	0.000	0	0.0	0
Run Time Recording	0.000	0	0.0	2
Safety Alarm	0.000	0	0.0	2
Totals	0.000	1,230	0.1	4
	MBtu/yr	kWh/yr	kW	mh/yr

Annual Energy Savings Table for Single Zone DX-A/C

Description: AC-5				
Strategy	MBtu/yr	kWh/yr	kW	mh/yr
Scheduled Start/Stop	0.000	1,256	0.0	0
Duty Cycling	0.000	524	0.0	0
Demand Limiting	0.000	0	0.2	0
Vent/Recirculation	0.000	0	0.0	0
Run Time Recording	0.000	0	0.0	2
Safety Alarm	0.000	0	0.0	2
Totals	0.000	1,780	0.2	4
	MBtu/yr	kWh/yr	kW	mh/yr

Annual Energy Savings Table for Steam Radiation

Description: RADIATION HEAT				
Strategy	MBtu/yr	kWh/yr	kW	mh/yr
Day/Night Setback	942.181	0	0.0	0
Run Time Recording	0.000	0	0.0	2
Safety Alarm	0.000	0	0.0	2
Subtotals	942.181	0	0.0	4
Heating Value /	1,031 Btu/cf			
Totals	913,851 cf /yr	0 kWh/yr	0.0 kW	4 mh/yr

EMCS Annual Energy Savings for Building 4700

Description	Value	Units
Natural gas (methane)	1,099,024	cf /yr
Electrical Energy	6,176	kWh/yr
Electrical Demand Reduction	0.7	kW
Labor Savings	24	mh/yr

FT. MEADE, MARYLAND

Building: 4703,4704,4717,4720,4721

Square feet 14,878

Exterior Wall	
Components	R-Value
Outside Surface	0.17
Concrete Block	1.72
Air Space	1.10
1/2" Drywall	0.56
Inside Surface	0.68
Total R-Value	4.23
Total U-Value	0.24

Exterior Roof	
Components	R-Value
Outside Surface	0.17
Built-up Roof	0.33
Wood Deck	0.93
Air Space	1.10
Acoustic Tile Clg	1.89
Inside Surface	0.61
Total R-Value	5.03
Total U-Value	0.20

Calculated Total Area	
No. of Floors	2
Avg. Floor to Floor Height	9
No. of Basement Levels	
Gross Floor Area	14878
Roof Area	7450
Estimated Infiltration (cfm)	1300
Gross Wall Area	7300
Door Area	200
Gross Window Area	1200
Other	
Net Wall Area	5900

Window and Door	
	U-Value
Window Single Pane W/Storm	
Window Single Pane Wo/Storm	
Window Double Pane	0.55
Skylight	
Glass Block	
Other	
Door Type 1	0.50
Door Type 2	
Door Type 3	

$$UoAo = (5900 \times 0.24) + (7450 \times 0.2) + (200 \times 0.5) + (1200 \times 0.55) = 3666$$

FT. MEADE, MARYLAND
EQUIPMENT SCHEDULE

BUILDING NO. 4703,4704,4717,4720,4721

EQUIPMENT	SYSTEM NUMBER							
	1	2	3	4	5	6	7	8
Equipment Name	Boiler	Chiller	Fan Coils	Boiler	Chiller	Fan Coils		
COOLING:								
Type of Cooling		3	3			3		Bldg 4704 sam
Air Side			1			1		as Bldg 4703
Location in Building	Bldg 4703	Bldg 4703	Bldg 4703	4717,4720,472	4717,4720,472	4717,4720,4721		
Area Sq. Feet								
Supply CFM								
Supply Fan HP			8			27		
O.A. CFM or %								
Return CFM								
Return Fan HP								
Chiller Tonnage		20			45			
Tower or Condenser Fan HP								
Condenser Pump HP								
Chilled Water Pump HP								
HEATING:								
Type of Heating	1			1				
Source	1			1				
MBTUH	1253/996			3570/2856				
Dual Temp Water Pump HP	2			4 1/2				
Condensate Pump HP								
ADDITIONAL:								
Aux. HP Cooling								
Aux. HP Heating								
Operating Schedule Hrs./Week								
Type of Cooling	(1) Air Cooled DX (4) Water Cooled Chiller (5) Central Plant Supplied (6) Other							
Type of Heating	(1) Boiler Hot Water (2) Boiler Steam (3) Steam to Hot Water Converter (4) Furnace							
Air Side	(1) Single Zone (2) Multi-Zone (3) VAV (4) VAV w/ Reheat (5) Constant Volume Reheat (6) Heating and Ventilating							
Heating Source	(1) Natural Gas (2) Central Plant Steam (3) Central Plant Hot Water (4) Oil (5) Electric							

EMCS Annual Energy Savings Summary Report

```

=====
Base: FTMEADE
Building: 4717
Case: 1
Description:
=====

```

```

=====
Fuel Type: Natural gas (methane)
Heating Value: 1,031 Btu/cf
=====

```

Caution

```

=====
The ESA program makes no attempt to exclude incompatible strategies.
It is the user's responsibility to select all appropriate strategies.
=====

```

Annual Energy Savings Table for Hot Water Boiler

```

=====
Description: HOT WATER BOILER
=====

```

Strategy	MBtu/yr	kWh/yr	kW	mh/yr
Hot Water OA Reset	93.975	0	0.0	0
Run Time Recording	0.000	0	0.0	2
Safety Alarm	0.000	0	0.0	2
Subtotals	93.975	0	0.0	4
Heating Value /	1,031 Btu/cf			
Totals	91,149 cf/yr	0 kWh/yr	0.0 kW	4 mh/yr

Annual Energy Savings Table for Air Cooled Chiller

```

=====
Description: CHILLER
=====

```

Strategy	MBtu/yr	kWh/yr	kW	mh/yr
Chiller Water Reset	0.000	1,086	0.0	0
Run Time Recording	0.000	0	0.0	2
Safety Alarm	0.000	0	0.0	2
Totals	0.000 MBtu/yr	1,086 kWh/yr	0.0 kW	4 mh/yr

EMCS Annual Energy Savings for Building 4717

Description	Value	Units
Natural gas (methane)	91,149	cf/yr
Electrical Energy	1,086	kWh/yr
Electrical Demand Reduction	0.0	kW
Labor Savings	8	mh/yr

FT. MEADE, MARYLAND

Building: 4705, 4707, 4709

Square feet 24,850

Exterior Wall	
Components	R-Value
Outside Surface	0.17
Concrete Block	1.72
Air Space	1.10
1/2" Drywall	0.56
Inside Surface	0.68
Total R-Value	4.23
Total U-Value	0.24

Exterior Roof	
Components	R-Value
Outside Surface	0.17
Built-up Roof	0.33
Wood Deck	0.93
Air Space	1.10
Acoustic Tile Clg	1.89
Inside Surface	0.61
Total R-Value	5.03
Total U-Value	0.20

Calculated Total Area	
No. of Floors	3
Avg. Floor to Floor Height	9
No. of Basement Levels	
Gross Floor Area	24850
Roof Area	8885
Estimated Infiltration (cfm)	2100
Gross Wall Area	14300
Door Area	90
Gross Window Area	1550
Other	
Net Wall Area	12660

Window and Door	
	U-Value
Window Single Pane W/Storm	
Window Single Pane Wo/Storm	
Window Double Pane	0.55
Skylight	
Glass Block	
Other	
Door Type 1	0.50
Door Type 2	
Door Type 3	

$$UoAo = (12660 \times 0.24) + (8885 \times 0.2) + (90 \times 0.5) + (1550 \times 0.55) = 5713$$

**FT. MEADE, MARYLAND
EQUIPMENT SCHEDULE**

BUILDING NO. 4705,4707,4709

Page 1 of 1

EQUIPMENT	SYSTEM NUMBER							
	1	2	3	4	5	6	7	8
Equipment Name	Boiler	Chiller	Fan Coils					
COOLING:				Bldg 4707 sam as Bldg 4705	Bldg 4709 same as Bldg 4705			
Type of Cooling	3	3	3					
Air Side			1					
Location in Building	Bldg 4705	Bldg 4705	Bldg 4705					
Area Sq. Feet								
Supply CFM								
Supply Fan HP			15					
O.A. CFM or %								
Return CFM								
Return Fan HP								
Chiller Tonnage		40						
Tower or Condenser Fan HP								
Condenser Pump HP								
Chilled Water Pump HP								
HEATING:								
Type of Heating	1							
Source	1							
MBTUH	1620/1215							
Dual Temp Water Pump HP	2							
Condensate Pump HP								
ADDITIONAL:								
Aux. HP Cooling								
Aux. HP Heating								
Operating Schedule Hrs./Week								
Type of Cooling	(4) Water Cooled Chiller (5) Central Plant Supplied (6) Other			Type of Heating (1) Boiler Hot Water (2) Boiler Steam (3) Steam to Hot Water Converter				
Air Side	(4) VAV w/ Reheat (5) Constant Volume Reheat (6) Heating and Ventilating			Heating Source (1) Natural Gas (2) Central Plant Steam (3) Central Plant Hot Water (4) Oil (5) Electric				

EMCS Annual Energy Savings Summary Report

```

=====
Base: FTMEADE
Building: 4705
Case: 1
Description:
=====

```

```

=====
Fuel Type: Natural gas (methane)
Heating Value: 1,031 Btu/cf
=====

```

Caution

```

=====
The ESA program makes no attempt to exclude incompatible strategies.
It is the user's responsibility to select all appropriate strategies.
=====

```

Annual Energy Savings Table for Hot Water Boiler

```

=====
Description: BOILER
=====

```

Strategy	MBtu/yr	kWh/yr	kW	mh/yr
Hot Water OA Reset	129.600	0	0.0	0
Run Time Recording	0.000	0	0.0	2
Safety Alarm	0.000	0	0.0	2
Subtotals	129.600	0	0.0	4
Heating Value /	1,031 Btu/cf			
Totals	125,703	0	0.0	4
	cf /yr	kWh/yr	kW	mh/yr

Annual Energy Savings Table for Air Cooled Chiller

```

=====
Description: CHILLER
=====

```

Strategy	MBtu/yr	kWh/yr	kW	mh/yr
Chiller Water Reset	0.000	2,172	0.0	0
Run Time Recording	0.000	0	0.0	2
Safety Alarm	0.000	0	0.0	2
Totals	0.000	2,172	0.0	4
	MBtu/yr	kWh/yr	kW	mh/yr

EMCS Annual Energy Savings for Building 4705

Description	Value	Units
Natural gas (methane)	125,703	cf /yr
Electrical Energy	2,172	kWh/yr
Electrical Demand Reduction	0.0	kW
Labor Savings	8	mh/yr

FT. MEADE, MARYLAND

Building: 6330

Square feet 41,900

Exterior Wall	
Components	R-Value
Outside Surface	0.17
4" CMU	1.11
Air Space	1.10
6" CMU	1.45
Inside Surface	0.68
Total R-Value	4.51
Total U-Value	0.22

Exterior Roof	
Components	R-Value
Outside Surface	0.17
Built up Roof	0.33
2" Insulation Rigid	12.00
2" concrete deck	0.93
Air Space	1.10
Acoustical Tile cig	1.89
Inside Surface	0.61
Total R-Value	17.03
Total U-Value	0.06

Calculated Total Area	
No. of Floors	2
Avg. Floor to Floor Height	18
No. of Basement Levels	
Gross Floor Area	41900
Roof Area	31300
Estimated Infiltration (cfm)	4000
Gross Wall Area	23000
Door Area	150
Gross Window Area	1000
Other	
Net Wall Area	21850

Window and Door	
	U-Value
Window Single Pane W/Storm	
Window Single Pane Wo/Storm	
Window Double Pane	0.55
Skylight	
Glass Block	
Other	
Door Type 1	1.00
Door Type 2	
Door Type 3	

EQUIPMENT	SYSTEM NUMBER							
	1	2	3	4	5	6	7	8
Equipment Name	H&V-1	H&V-2	HW Boiler	Pool Boiler				
COOLING:								
Type of Cooling								
Air Side	6	6						
Location in Building	All except Gym	Gym						
Area Sq. Feet								
Supply CFM	18310	24200						
Supply Fan HP	10	10						
O.A. CFM or %	100%	11000						
Return CFM								
Return Fan HP								
Chiller Tonnage								
Tower or Condenser Fan HP								
Condenser Pump HP								
Chilled Water Pump HP								
HEATING:								
Type of Heating			1	1				
Source			1	1				
MBTUH	810	810	2560	1340				
Hot Water Pump HP	5	1/2						
Condensate Pump HP								
ADDITIONAL:								
Aux. HP Cooling								
Aux. HP Heating								
Operating Schedule Hrs./Week								
Type of Cooling								
(1) Air Cooled DX								
(2) Water Cooled DX								
(3) Air Cooled Chiller								
Air Side								
(4) VAV w/ Reheat								
(5) Constant Volume Reheat								
(6) Heating and Ventilating								
Type of Heating								
(1) Boiler Hot Water								
(2) Boiler Steam								
(3) Steam to Hot Water Converter								
Heating Source								
(1) Natural Gas								
(2) Central Plant Steam								
(3) Central Plant Hot Water								
(4) Oil								
(5) Electric								

EMCS Annual Energy Savings Summary Report

```

=====
Base: FTMEADE
Building: 6330
Case: 1
Description:
=====

```

```

-----
Fuel Type: Natural gas (methane)
Heating Value: 1,031 Btu/cf
=====

```

Caution

```

=====
The ESA program makes no attempt to exclude incompatible strategies.
It is the user's responsibility to select all appropriate strategies.
=====

```

Annual Energy Savings Table for Hot Water Boiler

```

=====
Description: BOILER
=====

```

Strategy	MBtu/yr	kWh/yr	kW	mh/yr
Hot Water OA Reset	192.000	0	0.0	0
Subtotals	192.000	0	0.0	0
Heating Value /	1,031 Btu/cf			
Totals	186,227 cf /yr	0 kWh/yr	0.0 kW	0 mh/yr

EMCS Annual Energy Savings for Building 6330

Description	Value	Units
Natural gas (methane)	186,227	cf /yr
Electrical Energy	0	kWh/yr
Electrical Demand Reduction	0.0	kW
Labor Savings	0	mh/yr

**UMCS FEASIBILITY STUDY
FORT MEADE
BUILDING 6330 - PHYSICAL FITNESS CENTER
DOE ENERGY SAVINGS SUMMARY**

	Space Heat		Space Cool		HVAC Aux		Lights		Misc Equip		TOTAL		TOTAL	
	Electricity mmBtu	Natural Gas mmBtu	Electricity mmBtu	mmBtu	Electricity mmBtu	mmBtu	Electricity mmBtu	mmBtu	Electricity mmBtu	mmBtu	Electricity mmBtu	Natural Gas mmBtu	Electricity Kwh	Natural Gas MCF
Existing	300.5	8,894.2	0.0		931.0		622.9	7.2	1,861.6	8,894.2	545,441	8,626.8		
New w/Vent/Recirc	288.0	7,551.1	0.0		909.5		622.9	7.2	1,827.6	7,551.1	535,467	7,324.0		
Vent/Recirc Savings									34.0	1,343.2	9,974	1,302.8		
New w/Night Setback and Vent/Recirc	192.5	5,042.2	0.0		568.2		622.9	7.2	1,390.8	5,042.2	407,489	4,890.6		
Night Setback Savings									436.8	2,508.9	127,978	2,433.5		
									0.0	0.0	0	0.0		
									0.0	0.0	0	0.0		

MDDDH	HV-1	HV-1	HV-1	HV-1	HV-2	HV-2	HV-2	HV-2
	TOT HTG COIL PWR BTU/HR	SUPPLY ELECTRIC KW	HEATING CAPACITY BTU/HR	TOT FAN ELECTRIC KW	TOT HTG COIL PWR BTU/HR	SUPPLY ELECTRIC KW	HEATING CAPACITY BTU/HR	TOT FAN ELECTRIC KW
	---- (5)	----(49)	----(78)	----(33)	---- (5)	----(49)	----(78)	----(33)
MONTHLY SUMMARY (JAN)								
MN	-819909.	14.202	-810000.	14.202	-1262309.	13.627	-1254221.	14.345
MX	-183739.	14.202	-810000.	14.202	0.	13.627	-1254221.	14.345
SM	-438130176.	10566.195	-602640000.	10566.195	-466297920.	10138.312	-933140544.	10672.566
AV	-588885.	14.202	-810000.	14.202	-626745.	13.627	-1254221.	14.345
MONTHLY SUMMARY (FEB)								
MN	-830370.	14.202	-810000.	14.202	-1264962.	13.627	-1254221.	14.345
MX	-132814.	14.202	-810000.	14.202	0.	13.627	-1254221.	14.345
SM	-363321440.	9543.661	-544320000.	9543.661	-354412928.	9157.186	-842836608.	9639.737
AV	-540657.	14.202	-810000.	14.202	-527400.	13.627	-1254221.	14.345
MONTHLY SUMMARY (MAR)								
MN	-756859.	14.202	-810000.	14.202	-875396.	13.627	-1254221.	14.345
MX	0.	14.202	-810000.	14.202	0.	13.627	-1254221.	14.345
SM	-312274752.	10566.195	-602640000.	10566.195	-239555568.	10138.312	-933140544.	10672.566
AV	-419724.	14.202	-810000.	14.202	-321983.	13.627	-1254221.	14.345
MONTHLY SUMMARY (APR)								
MN	-656452.	14.202	-810000.	14.202	-697223.	13.627	-1254221.	14.345
MX	0.	14.202	-810000.	14.202	0.	13.627	-1254221.	14.345
SM	-201249056.	10225.351	-583200000.	10225.351	-102410520.	9811.270	-903039232.	10328.290
AV	-279513.	14.202	-810000.	14.202	-142237.	13.627	-1254221.	14.345
MONTHLY SUMMARY (MAY)								
MN	0.	14.202	0.	14.202	0.	13.627	0.	14.345
MX	0.	14.202	0.	14.202	0.	13.627	0.	14.345
SM	0.	10566.195	0.	10566.195	0.	10138.312	0.	10672.566
AV	0.	14.202	0.	14.202	0.	13.627	0.	14.345
MONTHLY SUMMARY (JUN)								
MN	0.	14.202	0.	14.202	0.	13.627	0.	14.345
MX	0.	14.202	0.	14.202	0.	13.627	0.	14.345
SM	0.	10225.351	0.	10225.351	0.	9811.270	0.	10328.290
AV	0.	14.202	0.	14.202	0.	13.627	0.	14.345
MONTHLY SUMMARY (JUL)								
MN	0.	14.202	0.	14.202	0.	13.627	0.	14.345
MX	0.	14.202	0.	14.202	0.	13.627	0.	14.345
SM	0.	10566.195	0.	10566.195	0.	10138.312	0.	10672.566
AV	0.	14.202	0.	14.202	0.	13.627	0.	14.345

	HV-1	HV-1	HV-1	HV-1	HV-2	HV-2	HV-2	HV-2
	TOT HTG COIL PWR BTU/HR	SUPPLY ELECTRIC KW	HEATING CAPACITY BTU/HR	TOT FAN ELECTRIC KW	TOT HTG COIL PWR BTU/HR	SUPPLY ELECTRIC KW	HEATING CAPACITY BTU/HR	TOT FAN ELECTRIC KW
	---- (5)	----(49)	----(78)	----(33)	---- (5)	----(49)	----(78)	----(33)
MONTHLY SUMMARY (AUG)								
MN	0.	14.202	0.	14.202	0.	13.627	0.	14.345
MX	0.	14.202	0.	14.202	0.	13.627	0.	14.345
SM	0.	10566.195	0.	10566.195	0.	10138.312	0.	10672.566
AV	0.	14.202	0.	14.202	0.	13.627	0.	14.345
MONTHLY SUMMARY (SEP)								
MN	0.	14.202	0.	14.202	0.	13.627	0.	14.345
MX	0.	14.202	0.	14.202	0.	13.627	0.	14.345
SM	0.	10225.351	0.	10225.351	0.	9811.270	0.	10328.290
AV	0.	14.202	0.	14.202	0.	13.627	0.	14.345
MONTHLY SUMMARY (OCT)								
MN	-562822.	14.202	-810000.	14.202	-593133.	13.627	-1254221.	14.345
MX	0.	14.202	0.	14.202	0.	13.627	0.	14.345
SM	-94443224.	10566.195	-311040000.	10566.195	-39514888.	10138.312	-481620864.	10672.566
AV	-126940.	14.202	-418065.	14.202	-53111.	13.627	-647340.	14.345
MONTHLY SUMMARY (NOV)								
MN	-643301.	14.202	-810000.	14.202	-709556.	13.627	-1254221.	14.345
MX	0.	14.202	-810000.	14.202	0.	13.627	-1254221.	14.345
SM	-264780528.	10225.351	-583200000.	10225.351	-182796288.	9811.270	-903039232.	10328.290
AV	-367751.	14.202	-810000.	14.202	-253884.	13.627	-1254221.	14.345
MONTHLY SUMMARY (DEC)								
MN	-798402.	14.202	-810000.	14.202	-1086531.	13.627	-1254221.	14.345
MX	-158046.	14.202	-810000.	14.202	0.	13.627	-1254221.	14.345
SM	-401653152.	10566.195	-602640000.	10566.195	-376216064.	10138.312	-933140544.	10672.566
AV	-539856.	14.202	-810000.	14.202	-505667.	13.627	-1254221.	14.345
YEARLY SUMMARY								
MN	-830370.	14.202	-810000.	14.202	-1264962.	13.627	-1254221.	14.345
MX	0.	14.202	0.	14.202	0.	13.627	0.	14.345
SM	-2075852416.	124408.430	-3829680128.	124408.430	-1761204224.	119370.438	-5929957376.	125660.859
AV	-236969.	14.202	-437178.	14.202	-201051.	13.627	-676936.	14.345

KNTECH ENGINEERING
READING, PA 19603
REPORT- PV-A EQUIPMENT SIZES

EZDOE - ELITE SOFTWARE DEVELOPMENT INC
FT. GEORGE G. MEADE

DOE-2.1D 1/ 3/1996 9:31:15 PDL RUN 1
EMCS STUDY WEATHER FILE- BALTIMORE, MD

EQUIPMENT	NUMBER		NUMBER		NUMBER		NUMBER		NUMBER	
	SIZE	INSTD	SIZE	INSTD	SIZE	INSTD	SIZE	INSTD	SIZE	INSTD
	(MBTU/H)	AVAIL	(MBTU/H)	AVAIL	(MBTU/H)	AVAIL	(MBTU/H)	AVAIL	(MBTU/H)	AVAIL
HW-BOILER	3.200	1	1							

S I T E E N E R G Y													* SOURCE
	2	3	4	5	6	7	8	9	10	11	12	13	14
MONTH	TOTAL HEAT LOAD	TOTAL COOLING LOAD	TOTAL ELECTR LOAD	RCVRED ENERGY	WASTED RCVRABL ENERGY	FUEL INPUT COOLING	ELEC INPUT COOLING	FUEL INPUT HEATING	ELEC INPUT HEATING	FUEL INPUT ELECT	TOTAL FUEL INPUT	TOTAL SITE ENERGY	TOTAL SOURCE ENERGY
JAN	1362.3	0.0	189.9 55.6E	0.0	0.0	0.0	0.0 0.0E	1857.4	64.1 18.8E	0.0	1857.4	2047.2	2427.5
FEB	1119.8	0.0	171.1 50.1E	0.0	0.0	0.0	0.0 0.0E	1548.6	57.5 16.9E	0.0	1548.6	1719.7	2062.5
MAR	929.2	0.0	188.0 55.0E	0.0	0.0	0.0	0.0 0.0E	1343.3	60.7 17.8E	0.0	1343.3	1531.3	1907.8
APR	582.6	0.0	172.6 50.6E	0.0	0.0	0.0	0.0 0.0E	886.4	50.4 14.8E	0.0	886.4	1059.0	1404.8
MAY	0.0	0.0	125.7 36.8E	0.0	0.0	0.0	0.0 0.0E	0.0	0.0 0.0E	0.0	0.0	125.7	377.5
JUN	0.0	0.0	122.9 36.0E	0.0	0.0	0.0	0.0 0.0E	0.0	0.0 0.0E	0.0	0.0	122.9	369.2
JUL	0.0	0.0	125.0 36.6E	0.0	0.0	0.0	0.0 0.0E	0.0	0.0 0.0E	0.0	0.0	125.0	375.3
AUG	0.0	0.0	127.3 37.3E	0.0	0.0	0.0	0.0 0.0E	0.0	0.0 0.0E	0.0	0.0	127.3	382.1
SEP	0.0	0.0	122.2 35.8E	0.0	0.0	0.0	0.0 0.0E	0.0	0.0 0.0E	0.0	0.0	122.2	366.9
OCT	269.9	0.0	150.0 43.9E	0.0	0.0	0.0	0.0 0.0E	415.2	25.0 7.3E	0.0	415.2	565.1	865.5
NOV	783.2	0.0	177.1 51.9E	0.0	0.0	0.0	0.0 0.0E	1149.9	55.7 16.3E	0.0	1149.9	1327.0	1681.9
DEC	1216.6	0.0	189.8 55.6E	0.0	0.0	0.0	0.0 0.0E	1693.5	64.1 18.8E	0.0	1693.5	1883.3	2263.4
	6263.6	0.0	1861.5 545.2E	0.0	0.0	0.0	0.0 0.0E	8894.3	377.6 110.6E	0.0	8894.3	10755.8	14484.4

NOTE-- ALL ENTRIES ARE IN MBTU EXCEPT
 ENTRIES FOLLOWED BY E ARE IN MWH (THOUSANDS OF KWH)

ENITECH ENGINEERING
 READING, PA 19603
 REPORT- PS-B MONTHLY PEAK AND TOTAL ENERGY USE

EZDOE - ELITE SOFTWARE DEVELOPMENT INC
 FT. GEORGE G. MEADE

DOE-2.1D 1/ 3/1996 9:31:15 PDL RUN 1
 EMCS STUDY WEATHER FILE- BALTIMORE, MD

MO	UTILITY-	ELECTRICITY	NATURAL-GAS
	TOTAL (MBTU)	189.852	1857.372
JAN	PEAK (KBTU)	319.035	3690.027
	DY/HR	31/19	31/ 1
	TOTAL (MBTU)	171.131	1548.566
FEB	PEAK (KBTU)	319.035	3703.834
	DY/HR	28/ 7	3/ 5
	TOTAL (MBTU)	187.959	1343.334
MAR	PEAK (KBTU)	319.035	3087.852
	DY/HR	31/19	5/ 4
	TOTAL (MBTU)	172.610	886.437
APR	PEAK (KBTU)	319.035	2725.144
	DY/HR	29/ 9	9/ 8
	TOTAL (MBTU)	125.723	0.000
MAY	PEAK (KBTU)	232.318	0.000
	DY/HR	31/19	31/ 1
	TOTAL (MBTU)	122.949	0.000
JUN	PEAK (KBTU)	232.318	0.000
	DY/HR	30/19	30/ 1
	TOTAL (MBTU)	124.959	0.000
JUL	PEAK (KBTU)	232.318	0.000
	DY/HR	31/16	31/ 1
	TOTAL (MBTU)	127.252	0.000
AUG	PEAK (KBTU)	232.318	0.000
	DY/HR	31/19	31/ 1
	TOTAL (MBTU)	122.185	0.000
SEP	PEAK (KBTU)	232.318	0.000
	DY/HR	30/19	30/ 1
	TOTAL (MBTU)	149.963	415.178
OCT	PEAK (KBTU)	319.035	2405.848
	DY/HR	29/10	28/ 5
	TOTAL (MBTU)	177.145	1149.890
NOV	PEAK (KBTU)	319.035	2682.680
	DY/HR	30/19	9/ 5
	TOTAL (MBTU)	189.775	1693.475
DEC	PEAK (KBTU)	319.035	3357.869
	DY/HR	31/16	21/ 5
	ONE YEAR	1861.503	8894.252
	USE/PEAK	319.035	3703.834

EMTECH ENGINEERING
READING, PA 19603
REPORT- PS-D PLANT LOADS SATISFIED

EZDOE - ELITE SOFTWARE DEVELOPMENT INC
FT. GEORGE G. MEADE

DOB-2.1D 1/ 3/1996 9:31:15 PDL RUN 1
EMCS STUDY WEATHER FILE- BALTIMORE, MD

HEATING LOADS	MBTU SUPPLIED	PCT OF TOTAL LOAD
-----	-----	-----
HW-BOILER	6263.6	100.0
	=====	=====
LOAD SATISFIED	6263.6	100.0
TOTAL LOAD ON PLANT	6263.6	

ELECTRICAL LOADS	MBTU SUPPLIED	PCT OF TOTAL LOAD
-----	-----	-----
ELECTRICITY	1861.5	100.0
	=====	=====
LOAD SATISFIED	1861.5	100.0
TOTAL LOAD ON PLANT	1861.4	

ENTECH ENGINEERING
READING, PA 19603
REPORT- PS-D PLANT LOADS SATISFIED

EZDOE - ELITE SOFTWARE DEVELOPMENT INC
FT. GEORGE G. MEADE

DOR-2.1D 1/ 3/1996
EMCS STUDY

9:31:15 PDL RUN 1

WEATHER FILE- BALTIMORE, MD

----- (CONTINUED) -----

SUMMARY OF LOADS MET

TYPE OF LOAD	TOTAL LOAD (MBTU)	LOAD SATISFIED (MBTU)	TOTAL OVERLOAD (MBTU)	PEAK OVERLOAD (MBTU)	HOURS OVERLOADED
HEATING LOADS	6263.6	6263.6	0.000	0.000	0
ELECTRICAL LOADS	1861.4	1861.5	0.000	0.000	0

ENTECH ENGINEERING
READING, PA 19603
REPORT- PS-H EQUIPMENT USE STATISTICS

EZDOE - ELITE SOFTWARE DEVELOPMENT INC
FT. GEORGE G. MEADE

DOE-2.1D 1/ 3/1996 9:31:15 PDL RUN 1
EMCS STUDY WEATHER FILE- BALTIMORE, MD

EQUIPMENT	Avg	Max	MON		-----		-----		-----		-----		-----	
	OPER RATIO	LOAD (MBTU)	DAY	HR	SIZE (MBTU)	OPER HRS	SIZE (MBTU)	OPER HRS	SIZE (MBTU)	OPER HRS	SIZE (MBTU)	OPER HRS	SIZE (MBTU)	OPER HRS
HW-BOILER	0.414	2.920	2	3	5	3.200	4728							

E Q U I P M E N T T O T A L S

HW-BOILER	85.6		
NOMINAL SIZE (MBTU)		3.200	
NUMBER INSTALLED			1
FIRST COST (K\$)	77.3		77.3
ANNUAL COST (K\$)	1.1		1.1
CYCLICAL COST (K\$)	7.2		7.2
----TOTAL---- (K\$)			85.6
<hr/>			
EQUIPMENT TOTAL	85.6		

ENERGY TYPE IN SITE MBTU -	ELECTRICITY	NATURAL-GAS
CATEGORY OF USE		
SPACE HEAT	300.46	8894.24
SPACE COOL	0.00	0.00
HVAC AUX	931.04	0.00
DOM HOT WTR	0.00	0.00
AUX SOLAR	0.00	0.00
LIGHTS	622.91	0.00
VERT TRANS	0.00	0.00
MISC EQUIP	7.18	0.00
TOTAL	1861.58	8894.24

TOTAL SITE ENERGY 10755.76 MBTU 309.7 KBTU/SQFT-YR GROSS-AREA 309.7 KBTU/SQFT-YR NET-AREA
 TOTAL SOURCE ENERGY 14484.35 MBTU 417.0 KBTU/SQFT-YR GROSS-AREA 417.0 KBTU/SQFT-YR NET-AREA

PERCENT OF HOURS ANY SYSTEM ZONE OUTSIDE OF THROTTLING RANGE = 2.7
 PERCENT OF HOURS ANY PLANT LOAD NOT SATISFIED = 0.0

NOTE ELECTRICITY AND/OR FUEL USED TO GENERATE ELECTRICITY IS APPORTIONED BASED
 ON THE YEARLY DEMAND. ALL OTHER ENERGY TYPES ARE APPORTIONED HOURLY.

MDDHH	HW-BOILE R LOAD BTU/HR	HW-BOILE R ELECTRIC USE BTU/HR	HW-BOILE R FUEL USE BTU/HR
	---- (1)	---- (3)	---- (4)
MONTHLY SUMMARY (JAN)			
MN	479097.	42161.	782912.
MX	2906644.	70400.	3690027.
SM	1362284928.	51988668.	1857372160.
AV	1831028.	69877.	2496468.
MONTHLY SUMMARY (FEB)			
MN	312692.	27517.	510982.
MX	2919605.	70400.	3703834.
SM	1119796096.	46584968.	1548567424.
AV	1666363.	69323.	2304416.
MONTHLY SUMMARY (MAR)			
MN	17315.	1524.	28294.
MX	2350608.	70400.	3087852.
SM	929219264.	48567468.	1343333760.
AV	1248951.	65279.	1805556.
MONTHLY SUMMARY (APR)			
MN	17315.	1524.	28294.
MX	2023945.	70400.	2725144.
SM	582558144.	38675992.	886437248.
AV	809109.	53717.	1231163.
MONTHLY SUMMARY (OCT)			
MN	17315.	1524.	28294.
MX	1741190.	70400.	2405848.
SM	269949312.	18737868.	415177888.
AV	702993.	48797.	1081192.
MONTHLY SUMMARY (NOV)			
MN	17315.	1524.	28294.
MX	1986086.	70400.	2682680.
SM	783158848.	43974920.	1149890176.
AV	1087721.	61076.	1597070.
MONTHLY SUMMARY (DEC)			
MN	392037.	34499.	640644.
MX	2597751.	70400.	3357869.
SM	1216585088.	51912140.	1693475840.
AV	1635195.	69774.	2276177.

ENTECH ENGINEERING
READING, PA 19603
PH-1 = HOURLY-REPORT

EZDOE - ELITE SOFTWARE DEVELOPMENT INC
FT. GEORGE G. MEADE

DOE-2.1D 1/ 3/1996 9:31:15 PDL RUN 1
EMCS STUDY

PAGE 2- 1

HW-BOILE HW-BOILE HW-BOILE
R R R
LOAD ELECTRIC FUEL
USE USE USE
BTU/HR BTU/HR BTU/HR
---- (1) ---- (3) ---- (4)

YEARLY SUMMARY
MN 17315. 1524. 28294.
MX 2919605. 70400. 3703834.
SM 6263552000. 300442016. 8894255104.
AV 1324778. 63545. 1881188.

BUILDING 6330
W/VENT CONTROL
FILE: FTM6330N

MDDHH	HV-1	HV-1	HV-1	HV-2	HV-2	HV-2
	TOT HTG COIL PWR BTU/HR	SUPPLY ELECTRIC KW	HEATING CAPACITY BTU/HR	TOT HTG COIL PWR BTU/HR	SUPPLY ELECTRIC KW	HEATING CAPACITY BTU/HR
	---- (5)	---- (49)	---- (78)	---- (5)	---- (49)	---- (78)
MONTHLY SUMMARY (JAN)						
MN	-865968.	14.202	-810000.	-832820.	13.627	-810000.
MX	-57428.	14.202	-810000.	0.	13.627	-810000.
SM	-310084512.	10566.195	-602640000.	-367230496.	10138.312	-602640000.
AV	-416780.	14.202	-810000.	-493589.	13.627	-810000.
MONTHLY SUMMARY (FEB)						
MN	-870718.	14.202	-810000.	-837201.	13.627	-810000.
MX	-19259.	14.202	-810000.	0.	13.627	-810000.
SM	-253877872.	9543.661	-544320000.	-275390272.	9157.186	-544320000.
AV	-377794.	14.202	-810000.	-409807.	13.627	-810000.
MONTHLY SUMMARY (MAR)						
MN	-750325.	14.202	-810000.	-825715.	13.627	-810000.
MX	0.	14.202	-810000.	0.	13.627	-810000.
SM	-205312736.	10566.195	-602640000.	-187392960.	10138.312	-602640000.
AV	-275958.	14.202	-810000.	-251872.	13.627	-810000.
MONTHLY SUMMARY (APR)						
MN	-656981.	14.202	-810000.	-697223.	13.627	-810000.
MX	0.	14.202	-810000.	0.	13.627	-810000.
SM	-123125760.	10225.351	-583200000.	-74949592.	9811.270	-583200000.
AV	-171008.	14.202	-810000.	-104097.	13.627	-810000.
MONTHLY SUMMARY (MAY)						
MN	0.	14.202	0.	0.	13.627	0.
MX	0.	14.202	0.	0.	13.627	0.
SM	0.	10566.195	0.	0.	10138.312	0.
AV	0.	14.202	0.	0.	13.627	0.
MONTHLY SUMMARY (JUN)						
MN	0.	14.202	0.	0.	13.627	0.
MX	0.	14.202	0.	0.	13.627	0.
SM	0.	10225.351	0.	0.	9811.270	0.
AV	0.	14.202	0.	0.	13.627	0.
MONTHLY SUMMARY (JUL)						
MN	0.	14.202	0.	0.	13.627	0.
MX	0.	14.202	0.	0.	13.627	0.
SM	0.	10566.195	0.	0.	10138.312	0.
AV	0.	14.202	0.	0.	13.627	0.

	HV-1	HV-1	HV-1	HV-2	HV-2	HV-2
	TOT HTG COIL PWR BTU/HR	SUPPLY ELECTRIC KW	HEATING CAPACITY BTU/HR	TOT HTG COIL PWR BTU/HR	SUPPLY ELECTRIC KW	HEATING CAPACITY BTU/HR
	---- (5)	----(49)	----(78)	----(5)	----(49)	----(78)
MONTHLY SUMMARY (AUG)						
MN	0.	14.202	0.	0.	13.627	0.
MX	0.	14.202	0.	0.	13.627	0.
SM	0.	10566.195	0.	0.	10138.312	0.
AV	0.	14.202	0.	0.	13.627	0.
MONTHLY SUMMARY (SEP)						
MN	0.	14.202	0.	0.	13.627	0.
MX	0.	14.202	0.	0.	13.627	0.
SM	0.	10225.351	0.	0.	9811.270	0.
AV	0.	14.202	0.	0.	13.627	0.
MONTHLY SUMMARY (OCT)						
MN	-559123.	14.202	-810000.	-593133.	13.627	-810000.
MX	0.	14.202	0.	0.	13.627	0.
SM	-55293340.	10566.195	-311040000.	-26820740.	10138.312	-311040000.
AV	-74319.	14.202	-418065.	-36049.	13.627	-418065.
MONTHLY SUMMARY (NOV)						
MN	-639179.	14.202	-810000.	-709556.	13.627	-810000.
MX	0.	14.202	-810000.	0.	13.627	-810000.
SM	-174170384.	10225.351	-583200000.	-139988656.	9811.270	-583200000.
AV	-241903.	14.202	-810000.	-194429.	13.627	-810000.
MONTHLY SUMMARY (DEC)						
MN	-834805.	14.202	-810000.	-832354.	13.627	-810000.
MX	-42500.	14.202	-810000.	0.	13.627	-810000.
SM	-278113408.	10566.195	-602640000.	-304865312.	10138.312	-602640000.
AV	-373808.	14.202	-810000.	-409765.	13.627	-810000.
YEARLY SUMMARY						
MN	-870718.	14.202	-810000.	-837201.	13.627	-810000.
MX	0.	14.202	0.	0.	13.627	0.
SM	-1399977984.	124408.430	-3829680128.	-1376638080.	119370.438	-3829680128.
AV	-159815.	14.202	-437178.	-157150.	13.627	-437178.

ENTECH ENGINEERING
READING, PA 19603
REPORT- PV-A EQUIPMENT SIZES

EZDOE - ELITE SOFTWARE DEVELOPMENT INC
FT. GEORGE G. MEADE

DOR-2.1D 1/ 3/1996 9:18:58 PDL RUN 1
EMCS STUDY

WEATHER FILE- BALTIMORE, MD

EQUIPMENT	NUMBER		NUMBER		NUMBER		NUMBER		NUMBER	
	SIZE	INSTD	SIZE	INSTD	SIZE	INSTD	SIZE	INSTD	SIZE	INSTD
	(MBTU/H)	AVAIL	(MBTU/H)	AVAIL	(MBTU/H)	AVAIL	(MBTU/H)	AVAIL	(MBTU/H)	AVAIL
HW-BOILER	3.200	1	1							

S I T E E N E R G Y													* SOURCE
MONTH	2	3	4	5	6	7	8	9	10	11	12	13	14
	TOTAL HEAT LOAD	TOTAL COOLING LOAD	TOTAL ELECTR LOAD	RCVRED ENERGY	WASTED RCVRABL ENERGY	FUEL INPUT COOLING	ELEC INPUT COOLING	FUEL INPUT HEATING	ELEC INPUT HEATING	FUEL INPUT ELECT	TOTAL FUEL INPUT	TOTAL SITE ENERGY	TOTAL SOURCE ENERGY
JAN	1147.5	0.0	187.8 55.0E	0.0	0.0	0.0	0.0	1611.6	63.9 18.7E	0.0	1611.6	1799.4	2175.5
FEB	927.4	0.0	168.4 49.3E	0.0	0.0	0.0	0.0	1323.1	56.5 16.5E	0.0	1323.1	1491.5	1828.9
MAR	765.7	0.0	184.5 54.0E	0.0	0.0	0.0	0.0	1144.7	59.1 17.3E	0.0	1144.7	1329.2	1698.8
APR	467.8	0.0	166.5 48.8E	0.0	0.0	0.0	0.0	728.8	46.0 13.5E	0.0	728.8	895.3	1228.7
MAY	0.0	0.0	123.9 36.3E	0.0	0.0	0.0	0.0	0.0	0.0	0.0	0.0	123.9	372.1
JUN	0.0	0.0	121.2 35.5E	0.0	0.0	0.0	0.0	0.0	0.0	0.0	0.0	121.2	363.9
JUL	0.0	0.0	123.1 36.1E	0.0	0.0	0.0	0.0	0.0	0.0	0.0	0.0	123.1	369.8
AUG	0.0	0.0	125.4 36.7E	0.0	0.0	0.0	0.0	0.0	0.0	0.0	0.0	125.4	376.7
SEP	0.0	0.0	120.4 35.3E	0.0	0.0	0.0	0.0	0.0	0.0	0.0	0.0	120.4	361.6
OCT	212.6	0.0	145.8 42.7E	0.0	0.0	0.0	0.0	335.6	22.7 6.6E	0.0	335.6	481.4	773.5
NOV	625.4	0.0	172.9 50.6E	0.0	0.0	0.0	0.0	951.8	53.2 15.6E	0.0	951.8	1124.7	1470.9
DEC	1011.3	0.0	187.6 54.9E	0.0	0.0	0.0	0.0	1455.5	63.7 18.7E	0.0	1455.5	1643.1	2018.9
*****	5157.6	0.0	1827.6 535.2E	0.0	0.0	0.0	0.0	7551.1	365.1 106.9E	0.0	7551.1	9378.6	13039.2

NOTE-- ALL ENTRIES ARE IN MBTU EXCEPT
 ENTRIES FOLLOWED BY E ARE IN MWH (THOUSANDS OF KWH)

ENTECH ENGINEERING
 READING, PA 19603
 REPORT- PS-B MONTHLY PEAK AND TOTAL ENERGY USE

EZDOE - ELITE SOFTWARE DEVELOPMENT INC
 FT. GEORGE G. MEADE

DOB-2.1D 1/ 3/1996 9:18:58 PDL RUN 1
 EMCS STUDY WEATHER FILE- BALTIMORE, MD

MO	UTILITY-	ELECTRICITY	NATURAL-GAS
	TOTAL (MBTU)	187.770	1611.644
JAN	PEAK (KBTU)	316.584	3363.009
	DY/HR	31/19	31/ 6
	TOTAL (MBTU)	168.430	1323.063
FEB	PEAK (KBTU)	316.584	3390.762
	DY/HR	28/ 7	5/ 6
	TOTAL (MBTU)	184.539	1144.655
MAR	PEAK (KBTU)	316.584	3053.485
	DY/HR	31/19	5/ 6
	TOTAL (MBTU)	166.469	728.820
APR	PEAK (KBTU)	316.584	2725.927
	DY/HR	29/ 9	9/ 8
	TOTAL (MBTU)	123.899	0.000
MAY	PEAK (KBTU)	229.866	0.000
	DY/HR	31/19	31/ 1
	TOTAL (MBTU)	121.184	0.000
JUN	PEAK (KBTU)	229.866	0.000
	DY/HR	30/19	30/ 1
	TOTAL (MBTU)	123.135	0.000
JUL	PEAK (KBTU)	229.866	0.000
	DY/HR	31/16	31/ 1
	TOTAL (MBTU)	125.427	0.000
AUG	PEAK (KBTU)	229.866	0.000
	DY/HR	31/19	31/ 1
	TOTAL (MBTU)	120.420	0.000
SEP	PEAK (KBTU)	229.866	0.000
	DY/HR	30/19	30/ 1
	TOTAL (MBTU)	145.814	335.615
OCT	PEAK (KBTU)	316.584	2386.650
	DY/HR	29/10	29/ 7
	TOTAL (MBTU)	172.853	951.816
NOV	PEAK (KBTU)	316.584	2647.685
	DY/HR	30/19	23/ 7
	TOTAL (MBTU)	187.612	1455.482
DEC	PEAK (KBTU)	316.584	3264.324
	DY/HR	31/16	21/ 6
	ONE YEAR	1827.552	7551.094
	USE/PEAK	316.584	3390.762

ENTECH ENGINEERING
READING, PA 19603
REPORT- PS-D PLANT LOADS SATISFIED

EZDOE - ELITE SOFTWARE DEVELOPMENT INC
FT. GEORGE G. MEADE

DOE-2.1D 1/ 3/1996 9:18:58 PDL RUN 1
EMCS STUDY WEATHER FILE- BALTIMORE, MD

HEATING LOADS MBTU SUPPLIED PCT OF TOTAL LOAD

HW-BOILER 5157.6 100.0

LOAD SATISFIED 5157.6 100.0
TOTAL LOAD ON PLANT 5157.6

ELECTRICAL LOADS MBTU SUPPLIED PCT OF TOTAL LOAD

ELECTRICITY 1827.6 100.0

LOAD SATISFIED 1827.6 100.0
TOTAL LOAD ON PLANT 1827.6

ENTECH ENGINEERING
READING, PA 19603
REPORT- PS-D PLANT LOADS SATISFIED

EZDOE - ELITE SOFTWARE DEVELOPMENT INC
FT. GEORGE G. MEADE

DOE-2.1D 1/ 3/1996
EMCS STUDY

9:18:58 PDL RUN 1

WEATHER FILE- BALTIMORE, MD

(CONTINUED)

SUMMARY OF LOADS MET

TYPE OF LOAD	TOTAL LOAD (MBTU)	LOAD SATISFIED (MBTU)	TOTAL OVERLOAD (MBTU)	PEAK OVERLOAD (MBTU)	HOURS OVERLOADED
HEATING LOADS	5157.6	5157.6	0.000	0.000	0
ELECTRICAL LOADS	1827.6	1827.6	0.000	0.000	0

ENTECH ENGINEERING
READING, PA 19603
REPORT- PS-H EQUIPMENT USE STATISTICS

EZDOE - ELITE SOFTWARE DEVELOPMENT INC
FT. GEORGE G. MEADE

DOE-2.1D 1/ 3/1996 9:18:58 PDL RUN 1
EMCS STUDY

WEATHER FILE- BALTIMORE, MD

EQUIPMENT	AVG	MAX	MON		---		---		---		---		---	
	OPER	LOAD	DAY	HR	SIZE	OPER	SIZE	OPER	SIZE	OPER	SIZE	OPER	SIZE	OPER
-----	RATIO	(MBTU)	---	---	(MBTU)	HRS	(MBTU)	HRS	(MBTU)	HRS	(MBTU)	HRS	(MBTU)	HRS
HW-BOILER	0.341	2.628	2	5	6	3.200	4728							

E Q U I P M E N T T O T A L S

HW-BOILER	85.6		
NOMINAL SIZE (MBTU)		3.200	
NUMBER INSTALLED			1
FIRST COST (K\$)	77.3		77.3
ANNUAL COST (K\$)	1.1		1.1
CYCLICAL COST (K\$)	7.2		7.2
-----TOTAL----- (K\$)			85.6

EQUIPMENT TOTAL	85.6		

ENERGY TYPE IN SITE MBTU -	ELECTRICITY	NATURAL-GAS
CATEGORY OF USE		
SPACE HEAT	287.97	7551.08
SPACE COOL	0.00	0.00
HVAC AUX	909.49	0.00
DOM HOT WTR	0.00	0.00
AUX SOLAR	0.00	0.00
LIGHTS	622.87	0.00
VERT TRANS	0.00	0.00
MISC EQUIP	7.18	0.00
TOTAL	1827.50	7551.08

TOTAL SITE ENERGY 9378.65 MBTU 270.0 KBTU/SQFT-YR GROSS-AREA 270.0 KBTU/SQFT-YR NET-AREA
 TOTAL SOURCE ENERGY 13039.24 MBTU 375.4 KBTU/SQFT-YR GROSS-AREA 375.4 KBTU/SQFT-YR NET-AREA

PERCENT OF HOURS ANY SYSTEM ZONE OUTSIDE OF THROTTLING RANGE = 4.1
 PERCENT OF HOURS ANY PLANT LOAD NOT SATISFIED = 0.0

NOTE ELECTRICITY AND/OR FUEL USED TO GENERATE ELECTRICITY IS APPORTIONED BASED
 ON THE YEARLY DEMAND. ALL OTHER ENERGY TYPES ARE APPORTIONED HOURLY.

 MDDHH HW-BOILE HW-BOILE HW-BOILE
 R R R
 LOAD ELECTRIC FUEL
 USE USE
 BTU/HR BTU/HR BTU/HR

----(1) ----(3) ----(4)

MONTHLY SUMMARY (JAN)

MN	390348.	34351.	637883.
MX	2602490.	70400.	3363009.
SM	1147512192.	51731336.	1611644288.
AV	1542355.	69531.	2166189.

MONTHLY SUMMARY (FEB)

MN	312640.	27512.	510897.
MX	2628097.	70400.	3390762.
SM	927372032.	45531612.	1323064576.
AV	1380018.	67755.	1968846.

MONTHLY SUMMARY (MAR)

MN	17315.	1524.	28294.
MX	2319399.	70400.	3053485.
SM	765667584.	46972584.	1144654080.
AV	1029123.	63135.	1538514.

MONTHLY SUMMARY (APR)

MN	17315.	1524.	28294.
MX	2024644.	70400.	2725927.
SM	467770720.	34301236.	728819840.
AV	649682.	47641.	1012250.

MONTHLY SUMMARY (OCT)

MN	17315.	1524.	28294.
MX	1724329.	70400.	2386650.
SM	212636784.	16413081.	335614432.
AV	553742.	42742.	873996.

MONTHLY SUMMARY (NOV)

MN	17315.	1524.	28294.
MX	1954946.	70400.	2647685.
SM	625355712.	41449440.	951816192.
AV	868550.	57569.	1321967.

MONTHLY SUMMARY (DEC)

MN	354275.	31176.	578935.
MX	2511737.	70400.	3264324.
SM	1011324992.	51573868.	1455481472.
AV	1359308.	69320.	1956292.

ENTECH ENGINEERING
READING, PA 19603
PH-1 = HOURLY-REPORT

EZDOE - ELITE SOFTWARE DEVELOPMENT INC
FT. GEORGE G. MEADE

DOE-2.1D 1/ 3/1996 9:18:58 PDL RUN 1
EMCS STUDY

HW-BOILE HW-BOILE HW-BOILE
R R R
LOAD ELECTRIC FUEL
USE USE
BTU/HR BTU/HR BTU/HR
---- (1) ---- (3) ---- (4)

YEARLY SUMMARY

MN	17315.	1524.	28294.
MX	2628097.	70400.	3390762.
SM	5157640192.	287973152.	7551094784.
AV	1090872.	60908.	1597101.

BUILDING 6330
W/VENT & SETBACK
FILE: FTM6330J

MDDHH	HV-1	HV-1	HV-1	HV-2	HV-2	HV-2
	TOT HTG COIL PWR BTU/HR	SUPPLY ELECTRIC KW	HEATING CAPACITY BTU/HR	TOT HTG COIL PWR BTU/HR	SUPPLY ELECTRIC KW	HEATING CAPACITY BTU/HR
	---- (5)	---- (49)	---- (78)	---- (5)	---- (49)	---- (78)
MONTHLY SUMMARY (JAN)						
MN	-819526.	0.000	-810000.	-814622.	0.000	-810000.
MX	0.	14.202	0.	0.	13.627	0.
SM	-319202368.	7356.570	-419579904.	-189643024.	6499.964	-386370048.
AV	-429035.	9.888	-563952.	-254897.	8.737	-519315.
MONTHLY SUMMARY (FEB)						
MN	-816512.	0.000	-810000.	-816175.	0.000	-810000.
MX	0.	14.202	0.	0.	13.627	0.
SM	-260466592.	6561.266	-374220032.	-134584544.	5859.506	-348300096.
AV	-387599.	9.764	-556875.	-200275.	8.720	-518304.
MONTHLY SUMMARY (MAR)						
MN	-757051.	0.000	-810000.	-625378.	0.000	-810000.
MX	0.	14.202	0.	0.	13.627	0.
SM	-193736720.	6447.652	-367740096.	-70342000.	6036.654	-358830080.
AV	-260399.	8.666	-494274.	-94546.	8.114	-482299.
MONTHLY SUMMARY (APR)						
MN	-737802.	0.000	-810000.	-495379.	0.000	-810000.
MX	0.	14.202	0.	0.	13.627	0.
SM	-112841048.	5836.971	-332910048.	-22895240.	5573.344	-331290080.
AV	-156724.	8.107	-462375.	-31799.	7.741	-460125.
MONTHLY SUMMARY (MAY)						
MN	0.	0.000	0.	0.	0.000	0.
MX	0.	14.202	0.	0.	13.627	0.
SM	0.	5893.778	0.	0.	5655.105	0.
AV	0.	7.922	0.	0.	7.601	0.
MONTHLY SUMMARY (JUN)						
MN	0.	0.000	0.	0.	0.000	0.
MX	0.	14.202	0.	0.	13.627	0.
SM	0.	5822.769	0.	0.	5586.971	0.
AV	0.	8.087	0.	0.	7.760	0.
MONTHLY SUMMARY (JUL)						
MN	0.	0.000	0.	0.	0.000	0.
MX	0.	14.202	0.	0.	13.627	0.
SM	0.	5822.769	0.	0.	5586.971	0.
AV	0.	7.826	0.	0.	7.509	0.

	HV-1	HV-1	HV-1	HV-2	HV-2	HV-2
	TOT HTG COIL PWR BTU/HR	SUPPLY ELECTRIC KW	HEATING CAPACITY BTU/HR	TOT HTG COIL PWR BTU/HR	SUPPLY ELECTRIC KW	HEATING CAPACITY BTU/HR
	---- (5)	----(49)	----(78)	----(5)	----(49)	----(78)
MONTHLY SUMMARY (AUG)						
MN	0.	0.000	0.	0.	0.000	0.
MX	0.	14.202	0.	0.	13.627	0.
SM	0.	6035.798	0.	0.	5791.373	0.
AV	0.	8.113	0.	0.	7.784	0.
MONTHLY SUMMARY (SEP)						
MN	0.	0.000	0.	0.	0.000	0.
MX	0.	14.202	0.	0.	13.627	0.
SM	0.	5751.760	0.	0.	5518.837	0.
AV	0.	7.989	0.	0.	7.665	0.
MONTHLY SUMMARY (OCT)						
MN	-618750.	0.000	-810000.	-387060.	0.000	-810000.
MX	0.	14.202	0.	0.	13.627	0.
SM	-49677824.	5865.375	-176580000.	-8033526.	5627.852	-176580000.
AV	-66771.	7.884	-237339.	-10798.	7.564	-237339.
MONTHLY SUMMARY (NOV)						
MN	-727804.	0.000	-810000.	-481675.	0.000	-810000.
MX	0.	14.202	0.	0.	13.627	0.
SM	-152082528.	5879.575	-335340032.	-44615884.	5614.225	-333720064.
AV	-211226.	8.166	-465750.	-61967.	7.798	-463500.
MONTHLY SUMMARY (DEC)						
MN	-769572.	0.000	-810000.	-760832.	0.000	-810000.
MX	0.	14.202	0.	0.	13.627	0.
SM	-268571264.	6859.505	-391230016.	-135085408.	6322.816	-375840064.
AV	-360983.	9.220	-525847.	-181566.	8.498	-505161.
YEARLY SUMMARY						
MN	-819526.	0.000	-810000.	-816175.	0.000	-810000.
MX	0.	14.202	0.	0.	13.627	0.
SM	-1356578304.	74133.797	-2397600256.	-605199616.	69673.617	-2310930432.
AV	-154861.	8.463	-273699.	-69087.	7.954	-263805.

S I T E E N E R G Y													
	2	3	4	5	6	7	8	9	10	11	12	13	14
MONTH	TOTAL HEAT LOAD	TOTAL COOLING LOAD	TOTAL ELECTR LOAD	RCVRED ENERGY	WASTED RCVRABL ENERGY	FUEL INPUT COOLING	ELEC INPUT COOLING	FUEL INPUT HEATING	ELEC INPUT HEATING	FUEL INPUT ELECT	TOTAL FUEL INPUT	TOTAL SITE ENERGY	TOTAL SOURCE ENERGY
JAN	808.1	0.0	150.0 43.9E	0.0	0.0	0.0	0.0	1140.3	49.5 14.5E	0.0	1140.3	1290.3	1590.8
FEB	650.8	0.0	134.8 39.5E	0.0	0.0	0.0	0.0	936.0	44.3 13.0E	0.0	936.0	1070.7	1340.7
MAR	496.7	0.0	139.6 40.9E	0.0	0.0	0.0	0.0	740.8	42.3 12.4E	0.0	740.8	880.4	1160.1
APR	292.6	0.0	124.0 36.3E	0.0	0.0	0.0	0.0	455.1	33.0 9.7E	0.0	455.1	579.1	827.5
MAY	0.0	0.0	92.6 27.1E	0.0	0.0	0.0	0.0	0.0	0.0 0.0E	0.0	0.0	92.6	278.2
JUN	0.0	0.0	91.7 26.9E	0.0	0.0	0.0	0.0	0.0	0.0 0.0E	0.0	0.0	91.7	275.5
JUL	0.0	0.0	91.4 26.8E	0.0	0.0	0.0	0.0	0.0	0.0 0.0E	0.0	0.0	91.4	274.5
AUG	0.0	0.0	95.1 27.9E	0.0	0.0	0.0	0.0	0.0	0.0 0.0E	0.0	0.0	95.1	285.6
SEP	0.0	0.0	90.5 26.5E	0.0	0.0	0.0	0.0	0.0	0.0 0.0E	0.0	0.0	90.5	271.7
OCT	130.0	0.0	107.9 31.6E	0.0	0.0	0.0	0.0	204.7	16.2 4.7E	0.0	204.7	312.5	528.6
NOV	385.8	0.0	127.5 37.3E	0.0	0.0	0.0	0.0	585.5	37.0 10.8E	0.0	585.5	712.9	968.2
DEC	678.5	0.0	145.6 42.6E	0.0	0.0	0.0	0.0	979.8	47.4 13.9E	0.0	979.8	1125.4	1417.1
-----	3442.4	0.0	1390.8 407.3E	0.0	0.0	0.0	0.0	5042.1	269.7 79.0E	0.0	5042.1	6432.8	9218.6

NOTE-- ALL ENTRIES ARE IN MBTU EXCEPT
 ENTRIES FOLLOWED BY E ARE IN MWH (THOUSANDS OF KWH)

MO	UTILITY-	ELECTRICITY	NATURAL-GAS
	TOTAL (MBTU)	150.033	1140.259
JAN	PEAK (KBTU)	316.584	3202.582
	DY/HR	31/19	31/ 7
	TOTAL (MBTU)	134.766	935.951
FEB	PEAK (KBTU)	316.584	3185.729
	DY/HR	28/ 8	4/ 5
	TOTAL (MBTU)	139.644	740.786
MAR	PEAK (KBTU)	316.584	2807.247
	DY/HR	31/19	4/ 6
	TOTAL (MBTU)	124.014	455.111
APR	PEAK (KBTU)	316.584	2531.869
	DY/HR	29/ 8	8/ 6
	TOTAL (MBTU)	92.637	0.000
MAY	PEAK (KBTU)	229.866	0.000
	DY/HR	31/19	31/ 1
	TOTAL (MBTU)	91.728	0.000
JUN	PEAK (KBTU)	229.866	0.000
	DY/HR	30/19	30/ 1
	TOTAL (MBTU)	91.398	0.000
JUL	PEAK (KBTU)	229.866	0.000
	DY/HR	31/16	31/ 1
	TOTAL (MBTU)	95.116	0.000
AUG	PEAK (KBTU)	229.866	0.000
	DY/HR	31/19	31/ 1
	TOTAL (MBTU)	90.489	0.000
SEP	PEAK (KBTU)	229.866	0.000
	DY/HR	30/19	30/ 1
	TOTAL (MBTU)	107.889	204.658
OCT	PEAK (KBTU)	316.584	2240.605
	DY/HR	29/10	28/ 5
	TOTAL (MBTU)	127.459	585.471
NOV	PEAK (KBTU)	316.584	2526.142
	DY/HR	30/19	8/ 5
	TOTAL (MBTU)	145.593	979.844
DEC	PEAK (KBTU)	316.584	3065.104
	DY/HR	31/16	22/ 5
	ONE YEAR	1390.766	5042.080
	USE/PEAK	316.584	3202.582

ENTECH ENGINEERING
READING, PA 19603
REPORT- PS-D PLANT LOADS SATISFIED

EZDOE - ELITE SOFTWARE DEVELOPMENT INC
FT. GEORGE G. MEADE

DOE-2.1D 1/ 2/1996 16:43:14 PDL RUN 1
EMCS STUDY WEATHER FILE- BALTIMORE, MD

HEATING LOADS	MBTU SUPPLIED	PCT OF TOTAL LOAD
-----	-----	-----
HW-BOILER	3442.5	100.0
	-----	-----
LOAD SATISFIED	3442.5	100.0
TOTAL LOAD ON PLANT	3442.5	
ELECTRICAL LOADS	MBTU SUPPLIED	PCT OF TOTAL LOAD
-----	-----	-----
ELECTRICITY	1390.8	100.0
	-----	-----
LOAD SATISFIED	1390.8	100.0
TOTAL LOAD ON PLANT	1390.8	

ENTECH ENGINEERING
READING, PA 19603
REPORT- PS-D PLANT LOADS SATISFIED

EZDOE - ELITE SOFTWARE DEVELOPMENT INC
FT. GEORGE G. MEADE

DOE-2.1D 1/ 2/1996 16:43:14 PDL RUN 1
EMCS STUDY

WEATHER FILE- BALTIMORE, MD

(CONTINUED)

SUMMARY OF LOADS MET

TYPE OF LOAD	TOTAL LOAD (MBTU)	LOAD SATISFIED (MBTU)	TOTAL OVERLOAD (MBTU)	PEAK OVERLOAD (MBTU)	HOURS OVERLOADED
HEATING LOADS	3442.5	3442.5	0.000	0.000	0
ELECTRICAL LOADS	1390.8	1390.8	0.000	0.000	0

ENTRECH ENGINEERING
READING, PA 19603
REPORT- PS-H EQUIPMENT USE STATISTICS

EZDOE - ELITE SOFTWARE DEVELOPMENT INC
FT. GEORGE G. MEADE

DOB-2.1D 1/ 2/1996 16:43:14 PDL RUN 1
EMCS STUDY WEATHER FILE- BALTIMORE, MD

EQUIPMENT	AVG	MAX	MON		SIZE OPER		SIZE OPER		SIZE OPER		SIZE OPER	
	OPER RATIO	LOAD (MBTU)	DAY HR		(MBTU)	HRS	(MBTU)	HRS	(MBTU)	HRS	(MBTU)	HRS
HW-BOILER	0.228	2.455	1	31	7	3.200	4728					

EQUIPMENT TOTALS

HW-BOILER	85.6		
NOMINAL SIZE (MBTU)		3.200	
NUMBER INSTALLED			1
FIRST COST (K\$)	77.3		77.3
ANNUAL COST (K\$)	1.1		1.1
CYCLICAL COST (K\$)	7.2		7.2
-----TOTAL----- (K\$)			85.6
<hr/>			
EQUIPMENT TOTAL	85.6		

ENERGY TYPE		
IN SITE MBTU -	ELECTRICITY	NATURAL-GAS
CATEGORY OF USE		
SPACE HEAT	192.52	5042.19
SPACE COOL	0.00	0.00
HVAC AUX	568.15	0.00
DOM HOT WTR	0.00	0.00
AUX SOLAR	0.00	0.00
LIGHTS	622.87	0.00
VERT TRANS	0.00	0.00
MISC EQUIP	7.18	0.00
	-----	-----
TOTAL	1390.72	5042.19

TOTAL SITE ENERGY 6432.85 MBTU 185.2 KBTU/SQFT-YR GROSS-AREA 185.2 KBTU/SQFT-YR NET-AREA
 TOTAL SOURCE ENERGY 9218.55 MBTU 265.4 KBTU/SQFT-YR GROSS-AREA 265.4 KBTU/SQFT-YR NET-AREA

PERCENT OF HOURS ANY SYSTEM ZONE OUTSIDE OF THROTTLING RANGE = 8.9
 PERCENT OF HOURS ANY PLANT LOAD NOT SATISFIED = 0.0

NOTE ELECTRICITY AND/OR FUEL USED TO GENERATE ELECTRICITY IS APPORTIONED BASED
 ON THE YEARLY DEMAND. ALL OTHER ENERGY TYPES ARE APPORTIONED HOURLY.

 MMDDHH HW-BOILE HW-BOILE HW-BOILE
 R R R
 LOAD ELECTRIC FUEL
 USE USE USE
 BTU/HR BTU/HR BTU/HR
 ---- (1) ---- (3) ---- (4)

MONTHLY SUMMARY (JAN)

MN	17315.	1524.	28294.
MX	2455196.	70400.	3202582.
SM	808060736.	37375616.	1140260352.
AV	1086103.	50236.	1532608.

MONTHLY SUMMARY (FEB)

MN	17315.	1524.	28294.
MX	2439794.	70400.	3185729.
SM	650764032.	33310252.	935951616.
AV	968399.	49569.	1392785.

MONTHLY SUMMARY (MAR)

MN	17315.	1524.	28294.
MX	2097370.	70400.	2807247.
SM	496670880.	30143704.	740787968.
AV	667568.	40516.	995683.

MONTHLY SUMMARY (APR)

MN	17315.	1524.	28294.
MX	1852266.	70400.	2531869.
SM	292572416.	21299500.	455112544.
AV	406351.	29583.	632101.

MONTHLY SUMMARY (OCT)

MN	17315.	1524.	28294.
MX	1596556.	70400.	2240605.
SM	129951376.	9939125.	204658336.
AV	338415.	25883.	532964.

MONTHLY SUMMARY (NOV)

MN	17315.	1524.	28294.
MX	1847203.	70400.	2526142.
SM	385826336.	25223728.	585471808.
AV	535870.	35033.	813155.

MONTHLY SUMMARY (DEC)

MN	17315.	1524.	28294.
MX	2329945.	70400.	3065104.
SM	678533568.	35237852.	979845568.
AV	912008.	47363.	1316997.

ENTTECH ENGINEERING
READING, PA 19603
- HOURLY-REPORT

EZDOE - ELITE SOFTWARE DEVELOPMENT INC
FT. GEORGE G. MEADE

DOE-2.1D 1/ 2/1996 16:43:14 PDL RUN 1
EMCS STUDY

PAGE 2- 1

HW-BOILE HW-BOILE HW-BOILE
R R R
LOAD ELECTRIC FUEL
USE USE USE
BTU/HR BTU/HR BTU/HR
---- (1) ---- (3) ---- (4)

YEARLY SUMMARY

MN	17315.	1524.	28294.
MX	2455196.	70400.	3202582.
SM	3442379520.	192529792.	5042087936.
AV	728084.	40721.	1066432.

FT. MEADE, MARYLAND

Building: 6530

Square feet 18,300

Exterior Wall	
Components	R-Value
Outside Surface	0.17
Concrete Block	2.18
Inside Surface	0.68
Total R-Value	3.03
Total U-Value	0.33

Exterior Roof	
Components	R-Value
Outside Surface	0.17
Built-up Roof	0.33
2" Insulation	8.00
Air Space	1.10
Inside Surface	0.61
Total R-Value	10.21
Total U-Value	0.10

Calculated Total Area	
No. of Floors	1
Avg. Floor to Floor Height	12
No. of Basement Levels	
Gross Floor Area	18300
Roof Area	18300
Estimated Infiltration (cfm)	3000
Gross Wall Area	11018
Door Area	3568
Gross Window Area	738
Other	
Net Wall Area	6712

Window and Door	
	U-Value
Window Single Pane W/Storm	0.60
Window Single Pane Wo/Storm	
Window Double Pane	
Skylight	
Glass Block	
Other	
Door Type 1	1.00
Door Type 2	
Door Type 3	

$$UoAo = (6712 \cdot 0.33) + (18300 \cdot 0.10) + (3568 \cdot 1.0) + (738 \cdot 0.6) = 8239$$

**FT. MEADE, MARYLAND
EQUIPMENT SCHEDULE**

BUILDING NO. 6530

Page 1 of 1

EQUIPMENT	SYSTEM NUMBER							
	1	2	3	4	5	6	7	8
Equipment Name	AHU-1	Boiler	H&V Unit	AHU-2	Unit Htrs	H&V Unit		
COOLING:	(only)							
Type of Cooling	1			1				
Air Side	5			1				
Location in Building	Craft Center		Garage	Garage Office	Garage	Woodworking		
Area Sq. Feet	6200		8000	1000	8000	3100		
Supply CFM	8530		8000	1200		5400		
Supply Fan HP	5		3	1	10	1 1/2		
O.A. CFM or %	3575		100%	20%		20%		
Return CFM								
Return Fan HP								
Chiller Tonnage	28			2				
Tower or Condenser Fan HP								
Condenser Pump HP								
Chilled Water Pump HP								
HEATING:								
Type of Heating		1						
Source		1			3			
MBTUH		2188						
Hot Water Pump HP	3/4		3/4	1	1			
Condensate Pump HP								
ADDITIONAL:								
Aux. HP Cooling								
Aux. HP Heating								
Operating Schedule Hrs./Week								
	Type of Cooling			Type of Heating				
(1) Air Cooled DX	(4) Water Cooled Chiller			(1) Boiler Hot Water			(4) Furnace	
(2) Water Cooled DX	(5) Central Plant Supplied			(2) Boiler Steam				
(3) Air Cooled Chiller	(6) Other			(3) Steam to Hot Water Converter				
	Air Side			Heating Source				
(1) Single Zone	(4) VAV w/ Reheat			(1) Natural Gas			(4) Oil	
(2) Multi-Zone	(5) Constant Volume Reheat			(2) Central Plant Steam			(5) Electric	
(3) VAV	(6) Heating and Ventilating			(3) Central Plant Hot Water				

EMCS Annual Energy Savings Summary Report

```

=====
Base: FTMEADE
Building: 6530
Case: 1
Description:
=====

```

```

-----
Fuel Type: Natural gas (methane)
Heating Value: 1,031 Btu/cf
=====

```

Caution

```

=====
The ESA program makes no attempt to exclude incompatible strategies.
It is the user's responsibility to select all appropriate strategies.
=====

```

Annual Energy Savings Table for Terminal Reheat AHU

```

=====
Description: AHU-1
=====

```

Strategy	MBtu/yr	kWh/yr	kW	mh/yr
Scheduled Start/Stop	377.331	11,335	0.0	0
Optimum Start/Stop	0.000	0	0.0	0
Demand Limiting	0.000	0	0.7	0
Economizer	0.000	0	0.0	0
Vent/Recirculation	28.430	0	0.0	0
Reheat Coil Reset	506.419	29,186	0.0	0
Run Time Recording	0.000	0	0.0	2
Safety Alarm	0.000	0	0.0	2

Subtotals	912.180	40,521	0.7	4
Heating Value /	1,031 Btu/cf			
=====				
Totals	884,753 cf /yr	40,521 kWh/yr	0.7 kW	4 mh/yr
=====				

Annual Energy Savings Table for Single Zone DX-A/C

Description: AHU-2				
Strategy	MBtu/yr	kWh/yr	kW	mh/yr
Demand Limiting	0.000	0	0.1	0
Day/Night Setback	17.771	107	0.0	0
Economizer	0.000	0	0.0	0
Vent/Recirculation	1.778	0	0.0	0
Run Time Recording	0.000	0	0.0	2
Safety Alarm	0.000	0	0.0	2
Subtotals	19.549	107	0.1	4
Heating Value /	1,031 Btu/cf			
Totals	18,961 cf /yr	107 kWh/yr	0.1 kW	4 mh/yr

Annual Energy Savings Table for Heating/Ventilating Unit

Description: H&V WOODWORKING				
Strategy	MBtu/yr	kWh/yr	kW	mh/yr
Day/Night Setback	44.269	0	0.0	0
Vent/Recirculation	8.571	0	0.0	0
Run Time Recording	0.000	0	0.0	2
Safety Alarm	0.000	0	0.0	2
Subtotals	52.839	0	0.0	4
Heating Value /	1,031 Btu/cf			
Totals	51,250 cf /yr	0 kWh/yr	0.0 kW	4 mh/yr

Annual Energy Savings Table for Heating/Ventilating Unit

Description: H&V GARAGE				
Strategy	MBtu/yr	kWh/yr	kW	mh/yr
Scheduled Start/Stop	504.060	2,944	0.0	0
Optimum Start/Stop	0.000	0	0.0	0
Vent/Recirculation	0.000	0	0.0	0
Run Time Recording	0.000	0	0.0	2
Safety Alarm	0.000	0	0.0	2
Subtotals	504.060	2,944	0.0	4
Heating Value /	1,031 Btu/cf			
Totals	488,904 cf /yr	2,944 kWh/yr	0.0 kW	4 mh/yr

Annual Energy Savings Table for Hot Water Unit Heater

Description: UNIT HTRS				
Strategy	MBtu/yr	kWh/yr	kW	mh/yr
Day/Night Setback	131.060	0	0.0	0
Subtotals	131.060	0	0.0	0
Heating Value /	1,031 Btu/cf			
Totals	127,120 cf /yr	0 kWh/yr	0.0 kW	0 mh/yr

Annual Energy Savings Table for Hot Water Boiler

Description: BOILER				
Strategy	MBtu/yr	kWh/yr	kW	mh/yr
Hot Water OA Reset	187.543	0	0.0	0
Run Time Recording	0.000	0	0.0	2
Safety Alarm	0.000	0	0.0	2
Subtotals	187.543	0	0.0	4
Heating Value /	1,031 Btu/cf			
Totals	181,904 cf /yr	0 kWh/yr	0.0 kW	4 mh/yr

EMCS Annual Energy Savings for Building 6530

Description	Value	Units
Natural gas (methane)	1,752,891	cf /yr
Electrical Energy	43,572	kWh/yr
Electrical Demand Reduction	0.9	kW
Labor Savings	20	mh/yr

FT. MEADE, MARYLAND

Building: 6600

Square feet 23,552

Exterior Wall	
Components	R-Value
Outside Surface	0.17
Brick	0.44
Air Space	1.10
Concrete Block	1.72
Air Space	1.10
Gyp Board	0.56
Inside Surface	0.68
Total R-Value	5.77
Total U-Value	0.17

Exterior Roof	
Components	R-Value
Outside Surface	0.17
Built-up Roof	0.33
1 1/2" Rigid Insulation	11.00
Metal Deck	0.00
Air Space	1.10
Acoustical Tile Clg	1.89
Inside Surface	0.61
Total R-Value	15.10
Total U-Value	0.07

Calculated Total Area	
No. of Floors	1
Avg. Floor to Floor Height	16
No. of Basement Levels	0
Gross Floor Area	23552
Roof Area	23552
Estimated Infiltration (cfm)	1880
Gross Wall Area	6550
Door Area	90
Gross Window Area	970
Other	
Net Wall Area	5490

Window and Door	
	U-Value
Window Single Pane W/Storm	
Window Single Pane Wo/Storm	
Window Double Pane	0.55
Skylight	
Glass Block	
Other	
Door Type 1	0.50
Door Type 2	
Door Type 3	



**FT. MEADE, MARYLAND
EQUIPMENT SCHEDULE**

BUILDING NO. 6600

EQUIPMENT	SYSTEM NUMBER							
	1	2	3	4	5	6	7	8
Equipment Name	AHU-9	Boiler	Chiller					
COOLING:								
Type of Cooling	3		3					
Air Side	1							
Location in Building	Offices							
Area Sq. Feet	1255							
Supply CFM	1300							
Supply Fan HP	1/2							
O.A. CFM or %	30%							
Return CFM								
Return Fan HP								
Chiller Tonnage			90					
Tower or Condenser Fan HP			3					
Condenser Pump HP								
Chilled Water Pump HP			3					
HEATING:								
Type of Heating		1						
Source		1						
MBTUH		1750/1400						
Hot Water Pump HP		3						
Condensate Pump HP								
ADDITIONAL:								
Aux. HP Cooling								
Aux. HP Heating								
Operating Schedule Hrs./Week								
Type of Cooling	Type of Heating							
(1) Air Cooled DX	(1) Boiler Hot Water							
(2) Water Cooled DX	(2) Boiler Steam							
(3) Air Cooled Chiller	(3) Steam to Hot Water Converter							
	Heating Source							
(1) Single Zone	(1) Natural Gas							
(2) Multi-Zone	(2) Central Plant Steam							
(3) VAV	(3) Central Plant Hot Water							
	(4) Oil							
	(5) Electric							

44-36, c

**FT. MEADE, MARYLAND
EQUIPMENT SCHEDULE**

BUILDING NO. 6600

Page 1 of 2

EQUIPMENT	SYSTEM NUMBER							
	1	2	3	4	5	6	7	8
Equipment Name	AHU-1	AHU-2	AHU-3	AHU-4	AHU-5	AHU-6	AHU-7	AHU-8
COOLING:								
Type of Cooling	3	3	3	3	3	3	3	3
Air Side	1	1	1	1	1	1	1	1
Location in Building	R. Rear Ball Rm	Center Ball Rm	Front Ball Rm	Front Ball Rm	Informal Bar	Formal Bar	L Rear Ball Rm	Restaurant
Area Sq. Feet	2025	1640	840	840	1635	1140	1190	2350
Supply CFM	4000	5000	2300	1900	4900	2800	2800	5400
Supply Fan HP	5	5	1	1	5	1 1/2	2	7 1/2
O.A. CFM or %	30%	30%	690	30%	30%	30%	30%	30%
Return CFM								
Return Fan HP								
Chiller Tonnage								
Tower or Condenser Fan HP								
Condenser Pump HP								
Chilled Water Pump HP								
HEATING:								
Type of Heating								
Source								
MBTUH								
Hot Water Pump HP								
Condensate Pump HP								
ADDITIONAL:								
Aux. HP Cooling								
Aux. HP Heating								
Operating Schedule Hrs./Week								
Type of Cooling	Type of Heating							
(1) Air Cooled DX	(1) Boiler Hot Water							
(2) Water Cooled DX	(2) Boiler Steam							
(3) Air Cooled Chiller	(3) Steam to Hot Water Converter							
	Air Side							
(1) Single Zone	(4) VAV w/ Reheat							
(2) Multi-Zone	(5) Constant Volume Reheat							
(3) VAV	(6) Heating and Ventilating							
	Heating Source							
	(1) Natural Gas							
	(2) Central Plant Steam							
	(3) Central Plant Hot Water							
	(4) Furnace							
	(4) Oil							
	(5) Electric							

EMCS Annual Energy Savings Summary Report

```

=====
Base: FTMEADE
Building: 6600
Case: 1
Description: OFFICERS CLUB
=====

```

```

-----
Fuel Type: Natural gas (methane)
Heating Value: 1,031      Btu/cf
=====

```

Caution

```

=====
The ESA program makes no attempt to exclude incompatible strategies.
It is the user's responsibility to select all appropriate strategies.
=====

```

Annual Energy Savings Table for Single Zone AHU

```

=====
Description: AHU-1
=====

```

Strategy	MBtu/yr	kWh/yr	kW	mh/yr
Demand Limiting	0.000	0	0.7	0
Totals	0.000	0	0.7	0
	MBtu/yr	kWh/yr	kW	mh/yr

```

=====

```

Annual Energy Savings Table for Single Zone AHU

```

=====
Description: AHU-2
=====

```

Strategy	MBtu/yr	kWh/yr	kW	mh/yr
Demand Limiting	0.000	0	0.7	0
Totals	0.000	0	0.7	0
	MBtu/yr	kWh/yr	kW	mh/yr

```

=====

```

Annual Energy Savings Table for Single Zone AHU

```

=====
/-----\
Description: AHU-3
=====
Strategy                MBtu/yr          kWh/yr          kW   mh/yr
=====
Demand Limiting         0.000            0                0.1   0
=====
Totals                   0.000            0                0.1   0
=====
                          MBtu/yr          kWh/yr          kW   mh/yr
=====
\-----/

```

Annual Energy Savings Table for Single Zone AHU

```

=====
/-----\
Description: AHU-4
=====
Strategy                MBtu/yr          kWh/yr          kW   mh/yr
=====
Demand Limiting         0.000            0                0.1   0
=====
Totals                   0.000            0                0.1   0
=====
                          MBtu/yr          kWh/yr          kW   mh/yr
=====
\-----/

```

Annual Energy Savings Table for Single Zone AHU

```

=====
/-----\
Description: AHU-5
=====
Strategy                MBtu/yr          kWh/yr          kW   mh/yr
=====
Demand Limiting         0.000            0                0.7   0
=====
Totals                   0.000            0                0.7   0
=====
                          MBtu/yr          kWh/yr          kW   mh/yr
=====
\-----/

```

Annual Energy Savings Table for Single Zone AHU

```

=====
/-----\
Description: AHU-6
=====
Strategy                MBtu/yr          kWh/yr          kW   mh/yr
=====
Demand Limiting         0.000            0                0.2   0
=====
Totals                   0.000            0                0.2   0
=====
                          MBtu/yr          kWh/yr          kW   mh/yr
=====
\-----/

```

Annual Energy Savings Table for Single Zone AHU

Description: AHU-7				
Strategy	MBtu/yr	kWh/yr	kW	mh/yr
Demand Limiting	0.000	0	0.3	0
Totals	0.000	0	0.3	0
	MBtu/yr	kWh/yr	kW	mh/yr

Annual Energy Savings Table for Single Zone AHU

Description: AHU-8				
Strategy	MBtu/yr	kWh/yr	kW	mh/yr
Demand Limiting	0.000	0	1.1	0
Totals	0.000	0	1.1	0
	MBtu/yr	kWh/yr	kW	mh/yr

Annual Energy Savings Table for Single Zone AHU

Description: AHU-9				
Strategy	MBtu/yr	kWh/yr	kW	mh/yr
Demand Limiting	0.000	0	0.0746000	0
Totals	0.000	0	0.0746000	0
	MBtu/yr	kWh/yr	kW	mh/yr

Annual Energy Savings Table for Hot Water Boiler

Description: BOILER				
Strategy	MBtu/yr	kWh/yr	kW	mh/yr
Hot Water OA Reset	131.250	0	0.0	0
Run Time Recording	0.000	0	0.0	2
Safety Alarm	0.000	0	0.0	2
Subtotals	131.250	0	0.0	4
Heating Value /	1,031 Btu/cf			
Totals	127,304 cf /yr	0 kWh/yr	0.0 kW	4 mh/yr

Annual Energy Savings Table for Air Cooled Chiller

Description: CHILLER				
Strategy	MBtu/yr	kWh/yr	kW	mh/yr
Scheduled Start/Stop	0.000	2,355	0.0	0
Chiller Water Reset	0.000	4,886	0.0	0
Run Time Recording	0.000	0	0.0	2
Safety Alarm	0.000	0	0.0	2
Totals	0.000 MBtu/yr	7,241 kWh/yr	0.0 kW	4 mh/yr

EMCS Annual Energy Savings for Building 6600

Description	Value	Units
Natural gas (methane)	127,304	cf /yr
Electrical Energy	7,241	kWh/yr
Electrical Demand Reduction	4.3	kW
Labor Savings	8	mh/yr

**UMCS FEASIBILITY STUDY
FORT MEADE
BUILDING 6600 - OFFICERS CLUB
DOE ENERGY SAVINGS SUMMARY**

	Space Heat		Space Cool		HVAC Aux		Lights		Misc Equip		TOTAL		TOTAL	
	Electricity mmBtu	Natural Gas mmBtu	Electricity mmBtu	Electricity mmBtu	Electricity mmBtu	Electricity mmBtu	Electricity mmBtu	Electricity mmBtu	Electricity mmBtu	Electricity mmBtu	Natural Gas mmBtu	Electricity mmBtu	Natural Gas mmBtu	Electricity Kwh
Existing	84.9	1,589.1	946.8	431.7	230.4	6.9	1,700.6	1,589.1	498,265	1,541.3				
New w/Night Setback	39.6	745.9	520.0	202.3	230.4	6.9	999.0	745.9	292,716	723.4				
Night Setback Savings							701.5	843.2	205,549	817.9				
New w/Night Setback and Vent/Recirc	30.6	576.1	532.9	195.7	230.4	6.9	996.5	576.1	291,972	558.8				
Vent/Recirc Savings							2.5	169.8	744	164.7				
New w/Night Setback & Vent/Recirc & Economizer	19.9	369.2	533.2	179.9	230.4	6.9	970.2	369.2	284,275	358.1				
Economizer Savings							26.3	206.8	7,697	200.6				

	AHU-1	AHU-1	AHU-1	AHU-1	AHU-1	AHU-2	AHU-2	AHU-2
	TOT HTG COIL PWR BTU/HR	TOT CLG COIL PWR BTU/HR	SUPPLY ELECTRIC KW	COOLING CAPACITY BTU/HR	HEATING CAPACITY BTU/HR	TOT HTG COIL PWR BTU/HR	TOT CLG COIL PWR BTU/HR	SUPPLY ELECTRIC KW
	---- (5)	---- (6)	----(49)	----(70)	---- (78)	---- (5)	---- (6)	----(49)
MONTHLY SUMMARY (AUG)								
MN	0.	0.	1.622	53856.	0.	0.	0.	1.630
MK	0.	97694.	1.622	119989.	0.	0.	97978.	1.630
SM	0.	17532704.	1207.066	64234124.	0.	0.	17578496.	1212.869
AV	0.	23565.	1.622	86336.	0.	0.	23627.	1.630
MONTHLY SUMMARY (SEP)								
MN	0.	0.	1.622	53856.	0.	0.	0.	1.630
MK	0.	82988.	1.622	121146.	0.	0.	83164.	1.630
SM	0.	11024335.	1168.128	51937320.	0.	0.	11035214.	1173.744
AV	0.	15312.	1.622	72135.	0.	0.	15327.	1.630
MONTHLY SUMMARY (OCT)								
MN	-28565.	0.	1.622	53856.	-117423.	-28793.	0.	1.630
MK	0.	50218.	1.622	119222.	0.	0.	50178.	1.630
SM	-2570764.	2904325.	1207.066	43801672.	-45090516.	-2595365.	2856526.	1212.869
AV	-3455.	3904.	1.622	58873.	-60606.	-3488.	3839.	1.630
MONTHLY SUMMARY (NOV)								
MN	-39386.	0.	1.622	53856.	-117423.	-39680.	0.	1.630
MK	0.	0.	1.622	129917.	-117423.	0.	0.	1.630
SM	-10221739.	0.	1168.128	42342804.	-84544728.	-10316444.	0.	1173.744
AV	-14197.	0.	1.622	58809.	-117423.	-14328.	0.	1.630
MONTHLY SUMMARY (DEC)								
MN	-55685.	0.	1.622	53856.	-117423.	-56090.	0.	1.630
MK	0.	0.	1.622	60947.	-117423.	0.	0.	1.630
SM	-17577026.	0.	1207.066	40093592.	-87362888.	-17744530.	0.	1212.869
AV	-23625.	0.	1.622	53889.	-117423.	-23850.	0.	1.630
YEARLY SUMMARY								
MN	-69618.	0.	1.622	53856.	-117423.	-70156.	0.	1.630
MK	0.	103881.	1.622	129917.	0.	0.	104154.	1.630
SM	-86926600.	71911008.	14212.227	569553536.	-555177088.	-87754800.	71994712.	14280.553
AV	-9923.	8209.	1.622	65018.	-63376.	-10018.	8219.	1.630

MMDDHH	AHU-2	AHU-2	AHU-3	AHU-3	AHU-3	AHU-3	AHU-3	AHU-3	AHU-4
	COOLING CAPACITY BTU/HR	HEATING CAPACITY BTU/HR	TOT HTG COIL PWR BTU/HR	TOT CLG COIL PWR BTU/HR	SUPPLY ELECTRIC KW	COOLING CAPACITY BTU/HR	HEATING CAPACITY BTU/HR	TOT HTG COIL PWR BTU/HR	
	----(70)	----(78)	----(5)	----(6)	----(49)	----(70)	----(78)	----(5)	
MONTHLY SUMMARY (JAN)									
MN	54097.	-117988.	-54631.	0.	1.084	36285.	-78470.	-31868.	
MX	90399.	-117988.	0.	0.	1.084	65926.	-78470.	0.	
SM	40409936.	-87782848.	-22078276.	0.	806.645	27149356.	-58381932.	-12249772.	
AV	54314.	-117988.	-29675.	0.	1.084	36491.	-78470.	-16465.	
MONTHLY SUMMARY (FEB)									
MN	54097.	-117988.	-54914.	0.	1.084	36285.	-78470.	-33309.	
MX	84519.	-117988.	0.	0.	1.084	60034.	-78470.	0.	
SM	36449968.	-79287736.	-18290508.	0.	728.583	24477492.	-52732068.	-10130295.	
AV	54241.	-117988.	-27218.	0.	1.084	36425.	-78470.	-15075.	
MONTHLY SUMMARY (MAR)									
MN	54097.	-117988.	-41092.	0.	1.084	36285.	-78470.	-24399.	
MX	90263.	-117988.	0.	0.	1.084	64625.	-78470.	0.	
SM	40530944.	-87782848.	-13715184.	0.	806.645	27218070.	-58381932.	-7496416.	
AV	54477.	-117988.	-18434.	0.	1.084	36583.	-78470.	-10076.	
MONTHLY SUMMARY (APR)									
MN	54097.	-117988.	-34716.	0.	1.084	36285.	-78470.	-20114.	
MX	109661.	-117988.	0.	0.	1.084	79616.	-78470.	0.	
SM	41464320.	-84951144.	-7013141.	0.	780.624	27789828.	-56498644.	-3541631.	
AV	57589.	-117988.	-9740.	0.	1.084	38597.	-78470.	-4919.	
MONTHLY SUMMARY (MAY)									
MN	54097.	0.	0.	0.	1.084	36285.	0.	0.	
MX	109582.	0.	0.	41923.	1.084	111566.	0.	0.	
SM	46248832.	0.	0.	2829946.	806.645	31410044.	0.	0.	
AV	62162.	0.	0.	3804.	1.084	42218.	0.	0.	
MONTHLY SUMMARY (JUN)									
MN	54097.	0.	0.	0.	1.084	36285.	0.	0.	
MX	121275.	0.	0.	65313.	1.084	127463.	0.	0.	
SM	56168136.	0.	0.	8980146.	780.624	37778464.	0.	0.	
AV	78011.	0.	0.	12472.	1.084	52470.	0.	0.	
MONTHLY SUMMARY (JUL)									
MN	54097.	0.	0.	0.	1.084	36285.	0.	0.	
MX	129470.	0.	0.	70744.	1.084	83124.	0.	0.	
SM	67296432.	0.	0.	14626723.	806.645	44630108.	0.	0.	
AV	90452.	0.	0.	19660.	1.084	59987.	0.	0.	

	AHU-2	AHU-2	AHU-3	AHU-3	AHU-3	AHU-3	AHU-3	AHU-4
	COOLING CAPACITY BTU/HR	HEATING CAPACITY BTU/HR	TOT HTG COIL PWR BTU/HR	TOT CLG COIL PWR BTU/HR	SUPPLY ELECTRIC KW	COOLING CAPACITY BTU/HR	HEATING CAPACITY BTU/HR	TOT HTG COIL PWR BTU/HR
	---- (70)	---- (78)	---- (5)	---- (6)	---- (49)	---- (70)	---- (78)	---- (5)
MONTHLY SUMMARY (AUG)								
MN	54097.	0.	0.	0.	1.084	36285.	0.	0.
MX	120197.	0.	0.	65649.	1.084	87662.	0.	0.
SM	64527664.	0.	0.	11954568.	806.645	42969980.	0.	0.
AV	86731.	0.	0.	16068.	1.084	57755.	0.	0.
MONTHLY SUMMARY (SEP)								
MN	54097.	0.	0.	0.	1.084	36285.	0.	0.
MX	121721.	0.	0.	58998.	1.084	80720.	0.	0.
SM	52167400.	0.	0.	7168318.	780.624	35050488.	0.	0.
AV	72455.	0.	0.	9956.	1.084	48681.	0.	0.
MONTHLY SUMMARY (OCT)								
MN	54097.	-117988.	-25120.	0.	1.084	36285.	-78470.	-15098.
MX	119422.	0.	0.	30059.	1.084	86459.	0.	0.
SM	44000508.	-45307284.	-3038488.	1187564.	806.645	29931540.	-30132610.	-1656617.
AV	59140.	-60897.	-4084.	1596.	1.084	40231.	-40501.	-2227.
MONTHLY SUMMARY (NOV)								
MN	54097.	-117988.	-34483.	0.	1.084	36285.	-78470.	-20220.
MX	130453.	-117988.	0.	0.	1.084	87028.	-78470.	0.
SM	42515376.	-84951144.	-11400741.	0.	780.624	28564256.	-56498644.	-6223105.
AV	59049.	-117988.	-15834.	0.	1.084	39673.	-78470.	-8643.
MONTHLY SUMMARY (DEC)								
MN	54097.	-117988.	-48075.	0.	1.084	36285.	-78470.	-28883.
MX	61011.	-117988.	-1061.	0.	1.084	45002.	-78470.	0.
SM	40272264.	-87782848.	-19209136.	0.	806.645	27041366.	-58381932.	-10516717.
AV	54129.	-117988.	-25819.	0.	1.084	36346.	-78470.	-14135.
YEARLY SUMMARY								
MN	54097.	-117988.	-54914.	0.	1.084	36285.	-78470.	-33309.
MX	130453.	0.	0.	70744.	1.084	127463.	0.	0.
SM	572051776.	-557845888.	-94745472.	46747264.	9497.596	384011040.	-371007744.	-51814552.
AV	65303.	-63681.	-10816.	5336.	1.084	43837.	-42352.	-5915.

MMDDHH	AHU-4	AHU-4	AHU-4	AHU-4	AHU-5	AHU-5	AHU-5	AHU-5
	TOT CLG COIL PWR BTU/HR	SUPPLY ELECTRIC KW	COOLING CAPACITY BTU/HR	HEATING CAPACITY BTU/HR	TOT HTG COIL PWR BTU/HR	TOT CLG COIL PWR BTU/HR	SUPPLY ELECTRIC KW	COOLING CAPACITY BTU/HR
	---- (6)	----(49)	----(70)	----(78)	---- (5)	---- (6)	----(49)	----(70)
MONTHLY SUMMARY (JAN)								
MN	0.	0.733	24512.	-53066.	-83170.	0.	1.521	49739.
MK	0.	0.733	44189.	-53066.	0.	0.	1.521	71113.
SM	0.	545.501	18335928.	-39481300.	-34980312.	0.	1131.624	37070032.
AV	0.	0.733	24645.	-53066.	-47017.	0.	1.521	49825.
MONTHLY SUMMARY (FEB)								
MN	0.	0.733	24512.	-53066.	-83752.	0.	1.521	49739.
MK	0.	0.733	40759.	-53066.	0.	0.	1.521	64786.
SM	0.	492.710	16531683.	-35660524.	-29104762.	0.	1022.112	33462094.
AV	0.	0.733	24601.	-53066.	-43311.	0.	1.521	49795.
MONTHLY SUMMARY (MAR)								
MN	0.	0.733	24512.	-53066.	-63656.	0.	1.521	49739.
MK	0.	0.733	43510.	-53066.	0.	0.	1.521	70197.
SM	0.	545.501	18387588.	-39481300.	-22143102.	0.	1131.624	37113740.
AV	0.	0.733	24715.	-53066.	-29762.	0.	1.521	49884.
MONTHLY SUMMARY (APR)								
MN	0.	0.733	24512.	-53066.	-53590.	0.	1.521	49739.
MK	0.	0.733	53153.	-53066.	0.	0.	1.521	87215.
SM	0.	527.904	18832132.	-38207708.	-11395959.	0.	1095.120	37096216.
AV	0.	0.733	26156.	-53066.	-15828.	0.	1.521	51523.
MONTHLY SUMMARY (MAY)								
MN	0.	0.733	24512.	0.	0.	0.	1.521	49739.
MK	29172.	0.733	74011.	0.	0.	51212.	1.521	132492.
SM	2225621.	545.501	21127692.	0.	0.	2950892.	1131.624	42271240.
AV	2991.	0.733	28397.	0.	0.	3966.	1.521	56816.
MONTHLY SUMMARY (JUN)								
MN	0.	0.733	24512.	0.	0.	0.	1.521	49739.
MK	44324.	0.733	58907.	0.	0.	84221.	1.521	153218.
SM	6292532.	527.904	25482492.	0.	0.	11913167.	1095.120	51244316.
AV	8740.	0.733	35392.	0.	0.	16546.	1.521	71173.
MONTHLY SUMMARY (JUL)								
MN	0.	0.733	24512.	0.	0.	0.	1.521	49739.
MK	47996.	0.733	56606.	0.	0.	91241.	1.521	111157.
SM	9819719.	545.501	30292080.	0.	0.	20070996.	1131.624	60492652.
AV	13199.	0.733	40715.	0.	0.	26977.	1.521	81307.

	AHU-4	AHU-4	AHU-4	AHU-4	AHU-5	AHU-5	AHU-5	AHU-5
	TOT CLG COIL PWR BTU/HR	SUPPLY ELECTRIC KW	COOLING CAPACITY BTU/HR	HEATING CAPACITY BTU/HR	TOT HTG COIL PWR BTU/HR	TOT CLG COIL PWR BTU/HR	SUPPLY ELECTRIC KW	COOLING CAPACITY BTU/HR
	---- (6)	---- (49)	---- (70)	---- (78)	---- (5)	---- (6)	---- (49)	---- (70)
MONTHLY SUMMARY (AUG)								
MN	0.	0.733	24512.	0.	0.	0.	1.521	49739.
MX	44680.	0.733	58165.	0.	0.	84884.	1.521	106787.
SM	8041847.	545.501	29152420.	0.	0.	15961378.	1131.624	58462312.
AV	10809.	0.733	39183.	0.	0.	21453.	1.521	78578.
MONTHLY SUMMARY (SEP)								
MN	0.	0.733	24512.	0.	0.	0.	1.521	49739.
MX	39319.	0.733	54812.	0.	0.	73336.	1.521	116197.
SM	4862969.	527.904	23714824.	0.	0.	8609963.	1095.120	47470620.
AV	6754.	0.733	32937.	0.	0.	11958.	1.521	65931.
MONTHLY SUMMARY (OCT)								
MN	0.	0.733	24512.	-53066.	-43285.	0.	1.521	49739.
MX	21660.	0.733	57510.	0.	0.	29903.	1.521	117155.
SM	1003271.	545.501	20124006.	-20377442.	-5280755.	511998.	1131.624	40336016.
AV	1348.	0.733	27048.	-27389.	-7098.	688.	1.521	54215.
MONTHLY SUMMARY (NOV)								
MN	0.	0.733	24512.	-53066.	-53317.	0.	1.521	49739.
MX	0.	0.733	58933.	-53066.	0.	0.	1.521	117251.
SM	0.	527.904	19309874.	-38207708.	-18448196.	0.	1095.120	38469712.
AV	0.	0.733	26819.	-53066.	-25622.	0.	1.521	53430.
MONTHLY SUMMARY (DEC)								
MN	0.	0.733	24512.	-53066.	-74852.	0.	1.521	49739.
MX	0.	0.733	29699.	-53066.	-8182.	0.	1.521	53068.
SM	0.	545.501	18260732.	-39481300.	-30625824.	0.	1131.624	37015396.
AV	0.	0.733	24544.	-53066.	-41164.	0.	1.521	49752.
YEARLY SUMMARY								
MN	0.	0.733	24512.	-53066.	-83752.	0.	1.521	49739.
MX	47996.	0.733	74011.	0.	0.	91241.	1.521	153218.
SM	32245960.	6422.832	259551440.	-250897280.	-151978912.	60018392.	13323.964	520504288.
AV	3681.	0.733	29629.	-28641.	-17349.	6851.	1.521	59418.

MMDDHH	AHU-5	AHU-6	AHU-6	AHU-6	AHU-6	AHU-6	AHU-7	AHU-7
	HEATING CAPACITY BTU/HR	TOT HTG COIL PWR BTU/HR	TOT CLG COIL PWR BTU/HR	SUPPLY ELECTRIC KW	COOLING CAPACITY BTU/HR	HEATING CAPACITY BTU/HR	TOT HTG COIL PWR BTU/HR	TOT CLG COIL PWR BTU/HR
	---- (78)	---- (5)	---- (6)	---- (49)	---- (70)	---- (78)	---- (5)	---- (6)
MONTHLY SUMMARY (JAN)								
MN	-110084.	-42174.	0.	0.858	28374.	-62099.	-36149.	0.
MX	-110084.	0.	0.	0.858	46145.	-62099.	0.	0.
SM	-81902720.	-17096420.	0.	638.352	21181368.	-46201532.	-12268381.	0.
AV	-110084.	-22979.	0.	0.858	28470.	-62099.	-16490.	0.
MONTHLY SUMMARY (FEB)								
MN	-110084.	-42566.	0.	0.858	28374.	-62099.	-41131.	0.
MX	-110084.	0.	0.	0.858	42052.	-62099.	0.	0.
SM	-73976648.	-14134831.	0.	576.576	19109282.	-41730416.	-10154449.	0.
AV	-110084.	-21034.	0.	0.858	28436.	-62099.	-15111.	0.
MONTHLY SUMMARY (MAR)								
MN	-110084.	-31715.	0.	0.858	28374.	-62099.	-28896.	0.
MX	-110084.	0.	0.	0.858	45094.	-62099.	0.	0.
SM	-81902720.	-10694945.	0.	638.352	21214078.	-46201532.	-7281680.	0.
AV	-110084.	-14375.	0.	0.858	28514.	-62099.	-9787.	0.
MONTHLY SUMMARY (APR)								
MN	-110084.	-26840.	0.	0.858	28374.	-62099.	-22479.	0.
MX	-110084.	0.	0.	0.858	56540.	-62099.	0.	0.
SM	-79260696.	-5408984.	0.	617.760	21434758.	-44711160.	-3032104.	0.
AV	-110084.	-7512.	0.	0.858	29770.	-62099.	-4211.	0.
MONTHLY SUMMARY (MAY)								
MN	0.	0.	0.	0.858	28374.	0.	0.	0.
MX	0.	0.	31230.	0.858	81388.	0.	0.	45486.
SM	0.	0.	1976244.	638.352	24305932.	0.	0.	4010156.
AV	0.	0.	2656.	0.858	32669.	0.	0.	5390.
MONTHLY SUMMARY (JUN)								
MN	0.	0.	0.	0.858	28374.	0.	0.	0.
MX	0.	0.	49302.	0.858	93447.	0.	0.	64601.
SM	0.	0.	6798058.	617.760	29423020.	0.	0.	9313291.
AV	0.	0.	9442.	0.858	40865.	0.	0.	12935.
MONTHLY SUMMARY (JUL)								
MN	0.	0.	0.	0.858	28374.	0.	0.	0.
MX	0.	0.	53280.	0.858	64399.	0.	0.	69792.
SM	0.	0.	11098984.	638.352	34852580.	0.	0.	13723391.
AV	0.	0.	14918.	0.858	46845.	0.	0.	18445.

	AHU-5	AHU-6	AHU-6	AHU-6	AHU-6	AHU-6	AHU-7	AHU-7
	HEATING CAPACITY BTU/HR	TOT HTG COIL PWR BTU/HR	TOT CLG COIL PWR BTU/HR	SUPPLY ELECTRIC KW	COOLING CAPACITY BTU/HR	HEATING CAPACITY BTU/HR	TOT HTG COIL PWR BTU/HR	TOT CLG COIL PWR BTU/HR
	----(78)	----(5)	----(6)	----(49)	----(70)	----(78)	----(5)	----(6)
MONTHLY SUMMARY (AUG)								
MN	0.	0.	0.	0.858	28374.	0.	0.	0.
MK	0.	0.	49229.	0.858	63202.	0.	0.	65171.
SM	0.	0.	8907756.	638.352	33612364.	0.	0.	11564326.
AV	0.	0.	11973.	0.858	45178.	0.	0.	15543.
MONTHLY SUMMARY (SEP)								
MN	0.	0.	0.	0.858	28374.	0.	0.	0.
MK	0.	0.	42945.	0.858	71747.	0.	0.	56723.
SM	0.	0.	5029351.	617.760	27330510.	0.	0.	7518405.
AV	0.	0.	6985.	0.858	37959.	0.	0.	10442.
MONTHLY SUMMARY (OCT)								
MN	-110084.	-20559.	0.	0.858	28374.	-62099.	-17087.	0.
MK	0.	0.	20990.	0.858	69313.	0.	0.	36172.
SM	-42272360.	-2488990.	567511.	638.352	23227734.	-23845952.	-1523473.	2448317.
AV	-56818.	-3345.	763.	0.858	31220.	-32051.	-2048.	3291.
MONTHLY SUMMARY (NOV)								
MN	-110084.	-27173.	0.	0.858	28374.	-62099.	-23538.	0.
MK	-110084.	0.	0.	0.858	67377.	-62099.	0.	0.
SM	-79260696.	-8880707.	0.	617.760	22119070.	-44711160.	-5934256.	0.
AV	-110084.	-12334.	0.	0.858	30721.	-62099.	-8242.	0.
MONTHLY SUMMARY (DEC)								
MN	-110084.	-37716.	0.	0.858	28374.	-62099.	-33371.	0.
MK	-110084.	-1523.	0.	0.858	32130.	-62099.	0.	0.
SM	-81902720.	-14806894.	0.	638.352	21123040.	-46201532.	-10105894.	0.
AV	-110084.	-19902.	0.	0.858	28391.	-62099.	-13583.	0.
YEARLY SUMMARY								
MN	-110084.	-42566.	0.	0.858	28374.	-62099.	-41131.	0.
MK	0.	0.	53280.	0.858	93447.	0.	0.	69792.
SM	-520478560.	-73511776.	34377904.	7516.079	298933728.	-293603296.	-50300240.	48577884.
AV	-59415.	-8392.	3924.	0.858	34125.	-33516.	-5742.	5545.

MMDDHH	AHU-7	AHU-7	AHU-7	AHU-8	AHU-8	AHU-8	AHU-8	AHU-8
	SUPPLY ELECTRIC KW	COOLING CAPACITY BTU/HR	HEATING CAPACITY BTU/HR	TOT HTG COIL PWR BTU/HR	TOT CLG COIL PWR BTU/HR	SUPPLY ELECTRIC KW	COOLING CAPACITY BTU/HR	HEATING CAPACITY BTU/HR
	----(49)	----(70)	----(78)	----(5)	----(6)	----(49)	----(70)	----(78)
MONTHLY SUMMARY (JAN)								
MN	1.045	35065.	-75648.	-171277.	0.	3.253	103258.	-235411.
MX	1.045	67037.	-75648.	0.	0.	3.253	127796.	-235411.
SM	777.629	26293134.	-56281856.	-69903776.	0.	2419.935	76875944.	-175145712.
AV	1.045	35340.	-75648.	-93957.	0.	3.253	103328.	-235411.
MONTHLY SUMMARY (FEB)								
MN	1.045	35065.	-75648.	-172867.	0.	3.253	103258.	-235411.
MX	1.045	63070.	-75648.	0.	0.	3.253	117447.	-235411.
SM	702.374	23692562.	-50835224.	-55901284.	0.	2185.748	69417424.	-158196144.
AV	1.045	35257.	-75648.	-83186.	0.	3.253	103300.	-235411.
MONTHLY SUMMARY (MAR)								
MN	1.045	35065.	-75648.	-126491.	0.	3.253	103258.	-235411.
MX	1.045	67622.	-75648.	0.	0.	3.253	129099.	-235411.
SM	777.629	26435148.	-56281856.	-41071032.	0.	2419.935	77087792.	-175145712.
AV	1.045	35531.	-75648.	-55203.	0.	3.253	103613.	-235411.
MONTHLY SUMMARY (APR)								
MN	1.045	35065.	-75648.	-108256.	0.	3.253	103258.	-235411.
MX	1.045	80121.	-75648.	0.	0.	3.253	166960.	-235411.
SM	752.544	27452040.	-54466312.	-20335410.	0.	2341.873	77258936.	-169495856.
AV	1.045	38128.	-75648.	-28244.	0.	3.253	107304.	-235411.
MONTHLY SUMMARY (MAY)								
MN	1.045	35065.	0.	0.	0.	3.253	103258.	0.
MX	1.045	71009.	0.	0.	104483.	3.253	193875.	0.
SM	777.629	30204572.	0.	0.	8358566.	2419.935	87003120.	0.
AV	1.045	40598.	0.	0.	11235.	3.253	116940.	0.
MONTHLY SUMMARY (JUN)								
MN	1.045	35065.	0.	0.	0.	3.253	103258.	0.
MX	1.045	79571.	0.	0.	169961.	3.253	213428.	0.
SM	752.544	36557024.	0.	0.	28994932.	2341.873	104071720.	0.
AV	1.045	50774.	0.	0.	40271.	3.253	144544.	0.
MONTHLY SUMMARY (JUL)								
MN	1.045	35065.	0.	0.	0.	3.253	103258.	0.
MX	1.045	84007.	0.	0.	180392.	3.253	232772.	0.
SM	777.629	43791048.	0.	0.	43888616.	2419.935	123075208.	0.
AV	1.045	58859.	0.	0.	58990.	3.253	165424.	0.

	AHU-7	AHU-7	AHU-7	AHU-8	AHU-8	AHU-8	AHU-8	AHU-8
	SUPPLY ELECTRIC KW	COOLING CAPACITY BTU/HR	HEATING CAPACITY BTU/HR	TOT HTG COIL PWR BTU/HR	TOT CLG COIL PWR BTU/HR	SUPPLY ELECTRIC KW	COOLING CAPACITY BTU/HR	HEATING CAPACITY BTU/HR
	----(49)	----(70)	----(78)	----(5)	----(6)	----(49)	----(70)	----(78)
MONTHLY SUMMARY (AUG)								
MN	1.045	35065.	0.	0.	0.	3.253	103258.	0.
MX	1.045	77748.	0.	0.	171418.	3.253	219264.	0.
SM	777.629	41924808.	0.	0.	35375888.	2419.935	119234832.	0.
AV	1.045	56351.	0.	0.	47548.	3.253	160262.	0.
MONTHLY SUMMARY (SEP)								
MN	1.045	35065.	0.	0.	0.	3.253	103258.	0.
MX	1.045	78938.	0.	0.	142615.	3.253	218688.	0.
SM	752.544	34018112.	0.	0.	18401850.	2341.873	97604632.	0.
AV	1.045	47247.	0.	0.	25558.	3.253	135562.	0.
MONTHLY SUMMARY (OCT)								
MN	1.045	35065.	-75648.	-88788.	0.	3.253	103258.	-235411.
MX	1.045	85029.	0.	0.	62573.	3.253	208622.	0.
SM	777.629	28694494.	-29048696.	-10218845.	2290556.	2419.935	82430040.	-90397816.
AV	1.045	38568.	-39044.	-13735.	3079.	3.253	110793.	-121502.
MONTHLY SUMMARY (NOV)								
MN	1.045	35065.	-75648.	-109883.	0.	3.253	103258.	-235411.
MX	1.045	85339.	-75648.	0.	0.	3.253	247552.	-235411.
SM	752.544	27935798.	-54466312.	-36570592.	0.	2341.873	79571664.	-169495856.
AV	1.045	38800.	-75648.	-50792.	0.	3.253	110516.	-235411.
MONTHLY SUMMARY (DEC)								
MN	1.045	35065.	-75648.	-148430.	0.	3.253	103258.	-235411.
MX	1.045	44788.	-75648.	-19718.	0.	3.253	109409.	-235411.
SM	777.629	26147308.	-56281856.	-61330492.	0.	2419.935	76840280.	-175145712.
AV	1.045	35144.	-75648.	-82433.	0.	3.253	103280.	-235411.
YEARLY SUMMARY								
MN	1.045	35065.	-75648.	-172867.	0.	3.253	103258.	-235411.
MX	1.045	85339.	0.	0.	180392.	3.253	247552.	0.
SM	9155.952	373146048.	-357662112.	-295331424.	137310416.	28492.787	1070471488.	-1113022848.
AV	1.045	42597.	-40829.	-33714.	15675.	3.253	122200.	-127057.

MMDDHR	AHU-9	AHU-9	AHU-9	AHU-9	AHU-9
	TOT HTG COIL PWR BTU/HR	TOT CLG COIL PWR BTU/HR	SUPPLY ELECTRIC KW	COOLING CAPACITY BTU/HR	HEATING CAPACITY BTU/HR
	---- (5)	---- (6)	----(49)	----(70)	----(78)
MONTHLY SUMMARY (JAN)					
MN	-24691.	0.	0.632	19159.	-45727.
MK	0.	0.	0.632	19684.	-45727.
SM	-8693259.	0.	470.059	14254821.	-34021124.
AV	-11684.	0.	0.632	19160.	-45727.
MONTHLY SUMMARY (FEB)					
MN	-27027.	0.	0.632	19159.	-45727.
MK	0.	0.	0.632	19159.	-45727.
SM	-7095111.	0.	424.570	12874847.	-30728756.
AV	-10558.	0.	0.632	19159.	-45727.
MONTHLY SUMMARY (MAR)					
MN	-19026.	0.	0.632	19159.	-45727.
MK	0.	0.	0.632	24017.	-45727.
SM	-5027855.	0.	470.059	14288120.	-34021124.
AV	-6758.	0.	0.632	19204.	-45727.
MONTHLY SUMMARY (APR)					
MN	-15778.	0.	0.632	19159.	-45727.
MK	0.	0.	0.632	29639.	-45727.
SM	-2020430.	0.	454.896	14183597.	-32923668.
AV	-2806.	0.	0.632	19699.	-45727.
MONTHLY SUMMARY (MAY)					
MN	0.	0.	0.632	19159.	0.
MK	0.	18122.	0.632	31853.	0.
SM	0.	1840113.	470.059	15869464.	0.
AV	0.	2473.	0.632	21330.	0.
MONTHLY SUMMARY (JUN)					
MN	0.	0.	0.632	19159.	0.
MK	0.	29808.	0.632	38170.	0.
SM	0.	5401540.	454.896	19184070.	0.
AV	0.	7502.	0.632	26645.	0.
MONTHLY SUMMARY (JUL)					
MN	0.	0.	0.632	19159.	0.
MK	0.	32236.	0.632	44401.	0.
SM	0.	8149689.	470.059	22778682.	0.
AV	0.	10954.	0.632	30617.	0.

	AHU-9	AHU-9	AHU-9	AHU-9	AHU-9
	TOT HTG COIL PWR BTU/HR	TOT CLG COIL PWR BTU/HR	SUPPLY ELECTRIC KW	COOLING CAPACITY BTU/HR	HEATING CAPACITY BTU/HR
	---- (5)	---- (6)	---- (49)	---- (70)	---- (78)
MONTHLY SUMMARY (AUG)					
MN	0.	0.	0.632	19159.	0.
MX	0.	30340.	0.632	40584.	0.
SM	0.	6873411.	470.059	21907108.	0.
AV	0.	9238.	0.632	29445.	0.
MONTHLY SUMMARY (SEP)					
MN	0.	0.	0.632	19159.	0.
MX	0.	24669.	0.632	41069.	0.
SM	0.	4053604.	454.896	17782474.	0.
AV	0.	5630.	0.632	24698.	0.
MONTHLY SUMMARY (OCT)					
MN	-12165.	0.	0.632	19159.	-45727.
MX	0.	12630.	0.632	29481.	0.
SM	-920704.	743280.	470.059	15045910.	-17559284.
AV	-1238.	999.	0.632	20223.	-23601.
MONTHLY SUMMARY (NOV)					
MN	-15711.	0.	0.632	19159.	-45727.
MX	0.	0.	0.632	45384.	-45727.
SM	-4061983.	0.	454.896	14746054.	-32923668.
AV	-5642.	0.	0.632	20481.	-45727.
MONTHLY SUMMARY (DEC)					
MN	-22347.	0.	0.632	19159.	-45727.
MX	0.	0.	0.632	20118.	-45727.
SM	-7314701.	0.	470.059	14257324.	-34021124.
AV	-9832.	0.	0.632	19163.	-45727.
YEARLY SUMMARY					
MN	-27027.	0.	0.632	19159.	-45727.
MX	0.	32236.	0.632	45384.	0.
SM	-35134040.	27061636.	5534.568	197172464.	-216198736.
AV	-4011.	3089.	0.632	22508.	-24680.

MMDDHH	FC-1	FC-1	FC-1	FC-1	FC-1
	TOT HTG COIL PWR BTU/HR	TOT CLG COIL PWR BTU/HR	SUPPLY ELECTRIC KW	COOLING CAPACITY BTU/HR	HEATING CAPACITY BTU/HR
	----(5)	----(6)	----(49)	----(70)	----(78)
MONTHLY SUMMARY (JAN)					
MN	0.	0.	0.090	27154.	0.
MX	0.	10466.	0.090	48134.	0.
SM	0.	146656.	67.183	25125724.	0.
AV	0.	197.	0.090	33771.	0.
MONTHLY SUMMARY (FEB)					
MN	0.	0.	0.090	27154.	0.
MX	0.	14001.	0.090	46280.	0.
SM	0.	316745.	60.682	21780968.	0.
AV	0.	471.	0.090	32412.	0.
MONTHLY SUMMARY (MAR)					
MN	0.	0.	0.090	27154.	0.
MX	0.	12196.	0.090	35563.	0.
SM	0.	370069.	67.183	21520312.	0.
AV	0.	497.	0.090	28925.	0.
MONTHLY SUMMARY (APR)					
MN	0.	0.	0.090	27154.	0.
MX	0.	11335.	0.090	44046.	0.
SM	0.	458044.	65.016	20253382.	0.
AV	0.	636.	0.090	28130.	0.
MONTHLY SUMMARY (MAY)					
MN	0.	0.	0.090	27555.	0.
MX	0.	0.	0.090	58849.	0.
SM	0.	0.	67.183	25199606.	0.
AV	0.	0.	0.090	33870.	0.
MONTHLY SUMMARY (JUN)					
MN	0.	0.	0.090	28694.	0.
MX	0.	0.	0.090	90392.	0.
SM	0.	0.	65.016	35370712.	0.
AV	0.	0.	0.090	49126.	0.
MONTHLY SUMMARY (JUL)					
MN	0.	0.	0.090	29097.	0.
MX	0.	0.	0.090	100250.	0.
SM	0.	0.	67.183	45682372.	0.
AV	0.	0.	0.090	61401.	0.

	FC-1	FC-1	FC-1	FC-1	FC-1
	TOT HTG COIL PWR BTU/HR	TOT CLG COIL PWR BTU/HR	SUPPLY ELECTRIC KW	COOLING CAPACITY BTU/HR	HEATING CAPACITY BTU/HR
	---- (5)	---- (6)	----(49)	---- (70)	---- (78)
MONTHLY SUMMARY (AUG)					
MN	0.	0.	0.090	28778.	0.
MX	0.	0.	0.090	90185.	0.
SM	0.	0.	67.183	42474312.	0.
AV	0.	0.	0.090	57089.	0.
MONTHLY SUMMARY (SEP)					
MN	0.	0.	0.090	28219.	0.
MX	0.	0.	0.090	84645.	0.
SM	0.	0.	65.016	31770184.	0.
AV	0.	0.	0.090	44125.	0.
MONTHLY SUMMARY (OCT)					
MN	0.	0.	0.090	27213.	0.
MX	0.	7711.	0.090	48781.	0.
SM	0.	66855.	67.183	22825316.	0.
AV	0.	90.	0.090	30679.	0.
MONTHLY SUMMARY (NOV)					
MN	0.	0.	0.090	27154.	0.
MX	0.	14220.	0.090	66276.	0.
SM	0.	301096.	65.016	21927992.	0.
AV	0.	418.	0.090	30456.	0.
MONTHLY SUMMARY (DEC)					
MN	0.	0.	0.090	27223.	0.
MX	0.	21282.	0.090	41428.	0.
SM	0.	364544.	67.183	23481384.	0.
AV	0.	490.	0.090	31561.	0.
YEARLY SUMMARY					
MN	0.	0.	0.090	27154.	0.
MX	0.	21282.	0.090	100250.	0.
SM	0.	2024009.	791.028	337412256.	0.
AV	0.	231.	0.090	38517.	0.

ENTECH ENGINEERING
READING, PA 19603
REPORT- PV-A EQUIPMENT SIZES

EZDOE - ELITE SOFTWARE DEVELOPMENT INC
FT. GEORGE G. MEADE

DOE-2.1D 1/10/1996 10:35: 4 EDL RUN 1
EMCS STUDY WEATHER FILE- BALTIMORE, MD

EQUIPMENT	NUMBER		NUMBER		NUMBER		NUMBER		NUMBER	
	SIZE	INSTD	SIZE	INSTD	SIZE	INSTD	SIZE	INSTD	SIZE	INSTD
	(MBTU/H)	AVAIL	(MBTU/H)	AVAIL	(MBTU/H)	AVAIL	(MBTU/H)	AVAIL	(MBTU/H)	AVAIL
HW-BOILER	1.800	1	1							
HERM-REC-CHLR	1.100	1	1							

S I T E E N E R G Y													* SOURCE
MONTH	2	3	4	5	6	7	8	9	10	11	12	13	14
	TOTAL HEAT LOAD	TOTAL COOLING LOAD	TOTAL ELECTR LOAD	RCVRED ENERGY	WASTED RCVRABL ENERGY	FUEL INPUT COOLING	ELBC INPUT COOLING	FUEL INPUT HEATING	ELBC INPUT HEATING	FUEL INPUT ELECT	TOTAL FUEL INPUT	TOTAL SITE ENERGY	TOTAL SOURCE ENERGY
JAN	222.4	4.8	84.2 24.7E	0.0	0.0	0.0	11.3 3.3E	361.4	20.8 6.1E	0.0	361.4	445.6	614.2
FEB	182.6	5.1	75.9 22.2E	0.0	0.0	0.0	11.9 3.5E	296.3	17.1 5.0E	0.0	296.3	372.3	524.3
MAR	135.8	5.1	76.8 22.5E	0.0	0.0	0.0	11.7 3.4E	221.9	13.6 4.0E	0.0	221.9	298.7	452.5
APR	66.4	4.8	69.3 20.3E	0.0	0.0	0.0	11.1 3.3E	108.5	7.4 2.2E	0.0	108.5	177.8	316.6
MAY	7.3	39.7	123.3 36.1E	0.0	0.0	0.0	69.5 20.4E	11.9	2.3 0.7E	0.0	11.9	135.2	382.1
JUN	3.6	114.3	233.9 68.5E	0.0	0.0	0.0	181.9 53.3E	5.8	1.9 0.6E	0.0	5.8	239.8	708.4
JUL	3.0	174.1	319.3 93.5E	0.0	0.0	0.0	264.8 77.5E	5.0	1.9 0.6E	0.0	5.0	324.3	963.9
AUG	3.3	143.8	282.9 82.9E	0.0	0.0	0.0	230.1 67.4E	5.3	1.9 0.6E	0.0	5.3	288.2	854.9
SEP	4.4	84.6	190.5 55.8E	0.0	0.0	0.0	137.8 40.4E	7.2	2.0 0.6E	0.0	7.2	197.7	579.3
OCT	39.4	17.7	90.9 26.6E	0.0	0.0	0.0	33.8 9.9E	64.3	5.1 1.5E	0.0	64.3	155.2	337.3
NOV	114.9	4.4	70.3 20.6E	0.0	0.0	0.0	10.3 3.0E	187.7	11.7 3.4E	0.0	187.7	258.0	398.8
DEC	192.1	5.2	83.2 24.4E	0.0	0.0	0.0	12.1 3.5E	313.7	18.5 5.4E	0.0	313.7	396.9	563.6
-----	975.1	603.7	1700.6 498.1E	0.0	0.0	0.0	986.4 288.9E	1589.0	104.0 30.5E	0.0	1589.0	3289.6	6695.9

NOTE-- ALL ENTRIES ARE IN MBTU EXCEPT
 ENTRIES FOLLOWED BY E ARE IN MWH (THOUSANDS OF KWH)

MO	UTILITY-	ELECTRICITY	NATURAL-GAS
	TOTAL (MBTU)	84.194	361.357
JAN	PEAK (KBTU)	189.904	874.291
	DY/HR	16/16	31/ 7
	TOTAL (MBTU)	75.906	296.347
FEB	PEAK (KBTU)	194.769	901.638
	DY/HR	3/11	3/ 6
	TOTAL (MBTU)	76.783	221.887
MAR	PEAK (KBTU)	179.064	698.108
	DY/HR	4/11	5/ 6
	TOTAL (MBTU)	69.289	108.533
APR	PEAK (KBTU)	176.190	591.635
	DY/HR	8/11	9/ 7
	TOTAL (MBTU)	123.274	11.932
MAY	PEAK (KBTU)	687.384	58.483
	DY/HR	21/17	10/ 5
	TOTAL (MBTU)	233.946	5.823
JUN	PEAK (KBTU)	769.504	25.220
	DY/HR	10/18	22/ 6
	TOTAL (MBTU)	319.337	4.958
JUL	PEAK (KBTU)	775.765	10.748
	DY/HR	24/17	21/ 5
	TOTAL (MBTU)	282.909	5.313
AUG	PEAK (KBTU)	773.964	25.030
	DY/HR	18/17	22/ 5
	TOTAL (MBTU)	190.491	7.226
SEP	PEAK (KBTU)	746.469	32.118
	DY/HR	1/17	30/ 7
	TOTAL (MBTU)	90.909	64.304
OCT	PEAK (KBTU)	650.049	501.167
	DY/HR	9/17	28/ 7
	TOTAL (MBTU)	70.295	187.711
NOV	PEAK (KBTU)	176.108	593.303
	DY/HR	17/11	23/ 7
	TOTAL (MBTU)	83.234	313.654
DEC	PEAK (KBTU)	180.968	803.684
	DY/HR	22/11	22/ 3
	ONE YEAR	1700.567	1589.046
	USE/PEAK	775.765	901.638

ENTTECH ENGINEERING
READING, PA 19603
REPORT- PS-D PLANT LOADS SATISFIED

EZDOE - ELITE SOFTWARE DEVELOPMENT INC
FT. GEORGE G. MEADE

DOE-2.1D 1/10/1996 10:35: 4 PDL RUN 1
EMCS STUDY WEATHER FILE- BALTIMORE, MD

HEATING LOADS	MBTU SUPPLIED	PCT OF TOTAL LOAD
-----	-----	-----
HW-BOILER	975.1	100.0
	=====	=====
LOAD SATISFIED	975.1	100.0
TOTAL LOAD ON PLANT	975.1	
COOLING LOADS	MBTU SUPPLIED	PCT OF TOTAL LOAD
-----	-----	-----
HERM-REC-CHLR	603.7	100.0
	=====	=====
LOAD SATISFIED	603.7	100.0
TOTAL LOAD ON PLANT	603.7	
ELECTRICAL LOADS	MBTU SUPPLIED	PCT OF TOTAL LOAD
-----	-----	-----
ELECTRICITY	1700.6	100.0
	=====	=====
LOAD SATISFIED	1700.6	100.0
TOTAL LOAD ON PLANT	1700.6	

ENTECH ENGINEERING
READING, PA 19603
REPORT- PS-D PLANT LOADS SATISFIED

EZDOE - ELITE SOFTWARE DEVELOPMENT INC
FT. GEORGE G. MEADE

DOE-2.1D 1/10/1996 10:35: 4 PDL RUN 1
EMCS STUDY

WEATHER FILE- BALTIMORE, MD

----- (CONTINUED) -----

SUMMARY OF LOADS MET

TYPE OF LOAD	TOTAL LOAD (MBTU)	LOAD SATISFIED (MBTU)	TOTAL OVERLOAD (MBTU)	PEAK OVERLOAD (MBTU)	HOURS OVERLOADED
HEATING LOADS	975.1	975.1	0.000	0.000	0
COOLING LOADS	603.7	603.7	0.000	0.000	0
ELECTRICAL LOADS	1700.6	1700.6	0.000	0.000	0

ENTTECH ENGINEERING
READING, PA 19603
REPORT- PS-H EQUIPMENT USE STATISTICS

EZDOE - ELITE SOFTWARE DEVELOPMENT INC
FT. GEORGE G. MEADE

DOE-2.1D 1/10/1996 10:35: 4 PDL RUN 1
EMCS STUDY WEATHER FILE- BALTIMORE, MD

EQUIPMENT	AVG	MAX	MON		---		---		---		---		---	
	OPER	LOAD	DAY	HR	SIZE	OPER	SIZE	OPER	SIZE	OPER	SIZE	OPER	SIZE	OPER
	RATIO	(MBTU)			(MBTU)	HRS	(MBTU)	HRS	(MBTU)	HRS	(MBTU)	HRS	(MBTU)	HRS
HW-BOILER	0.062	0.590	2	3	6	1.800	8760							
HERM-REC-CHLR	0.116	0.769	7	24	19	1.100	4733							

ENTECH ENGINEERING
READING, PA 19603
REPORT- PS-I EQUIPMENT LIFE CYCLE COSTS

EZDOE - ELITE SOFTWARE DEVELOPMENT INC
FT. GEORGE G. MEADE

DOE-2.1D 1/10/1996 10:35: 4 EDL RUN 1
EMCS STUDY WEATHER FILE- BALTIMORE, MD

E Q U I P M E N T T O T A L S

HW-BOILER	74.7		
NOMINAL SIZE (MBTU)		1.800	
NUMBER INSTALLED			1
FIRST COST (K\$)	52.6		52.6
ANNUAL COST (K\$)	1.0		1.0
CYCLICAL COST (K\$)	21.2		21.2
-----TOTAL---- (K\$)			74.7
HERM-RBC-CHLR	37.5		
NOMINAL SIZE (MBTU)		1.100	
NUMBER INSTALLED			1
FIRST COST (K\$)	24.2		24.2
ANNUAL COST (K\$)	2.3		2.3
CYCLICAL COST (K\$)	11.1		11.1
-----TOTAL---- (K\$)			37.5

EQUIPMENT TOTAL	112.3		

ENERGY TYPE	ELECTRICITY	NATURAL-GAS
IN SITE MBTU -		
CATEGORY OF USE		
SPACE HEAT	84.94	1589.08
SPACE COOL	946.75	0.00
HVAC AUX	431.67	0.00
DOM HOT WTR	0.00	0.00
AUX SOLAR	0.00	0.00
LIGHTS	230.36	0.00
VERT TRANS	0.00	0.00
MISC EQUIP	6.86	0.00
TOTAL	1700.58	1589.08

TOTAL SITE ENERGY 3289.61 MBTU 217.9 KBTU/SQFT-YR GROSS-AREA 217.9 KBTU/SQFT-YR NET-AREA
 TOTAL SOURCE ENERGY 6695.85 MBTU 443.5 KBTU/SQFT-YR GROSS-AREA 443.5 KBTU/SQFT-YR NET-AREA

PERCENT OF HOURS ANY SYSTEM ZONE OUTSIDE OF THROTTLING RANGE = 0.0
 PERCENT OF HOURS ANY PLANT LOAD NOT SATISFIED = 0.0

NOTE ELECTRICITY, AND/OR FUEL USED TO GENERATE ELECTRICITY IS APPORTIONED BASED
 ON THE YEARLY DEMAND. ALL OTHER ENERGY TYPES ARE APPORTIONED HOURLY.

MMDH	HW-BOILE R LOAD BTU/HR	HW-BOILE R ELECTRIC USE BTU/HR	HW-BOILE R FUEL USE BTU/HR	HERM-REC -CHLR LOAD BTU/HR	HERM-REC -CHLR ELECTRIC USE BTU/HR	HERM-REC -CHLR NOM CAP RUNNING BTU/HR
	----(1)	----(3)	----(4)	----(1)	----(3)	----(7)
MONTHLY SUMMARY (JAN)						
MN	3904.	344.	6380.	0.	0.	0.
MX	566755.	39600.	874291.	25550.	46117.	1100000.
SM	222388800.	19160012.	361356640.	4837762.	8733248.	342100000.
AV	298910.	25753.	485694.	6502.	11738.	459812.
MONTHLY SUMMARY (FEB)						
MN	3904.	344.	6380.	0.	0.	0.
MX	589886.	39600.	901638.	29085.	52494.	1100000.
SM	182571232.	15668431.	296347264.	5113438.	9230801.	349800000.
AV	271683.	23316.	440993.	7609.	13736.	520536.
MONTHLY SUMMARY (MAR)						
MN	3904.	344.	6380.	0.	0.	0.
MX	427202.	37594.	698108.	27280.	49238.	1100000.
SM	135782256.	11948841.	221887232.	5061175.	9140602.	342100000.
AV	182503.	16060.	298236.	6803.	12286.	459812.
MONTHLY SUMMARY (APR)						
MN	3904.	344.	6380.	0.	0.	0.
MX	362047.	31860.	591635.	26419.	47684.	1100000.
SM	66416260.	5844631.	108533432.	4817303.	8708114.	317900000.
AV	92245.	8118.	150741.	6691.	12095.	441528.
MONTHLY SUMMARY (MAY)						
MN	3904.	344.	6380.	0.	0.	0.
MX	35788.	3149.	58483.	462777.	559573.	1100000.
SM	7301804.	642559.	11932169.	39708944.	67030512.	330000000.
AV	9814.	864.	16038.	53372.	90095.	443548.
MONTHLY SUMMARY (JUN)						
MN	3904.	344.	6380.	0.	0.	0.
MX	15433.	1358.	25220.	715150.	641693.	1100000.
SM	3563443.	313583.	5823164.	114254696.	177163360.	624800000.
AV	4949.	436.	8088.	158687.	246060.	867778.
MONTHLY SUMMARY (JUL)						
MN	3904.	344.	6380.	0.	0.	0.
MX	6577.	579.	10748.	768800.	647953.	1100000.
SM	3033713.	266967.	4957512.	174091312.	258807952.	782099968.
AV	4078.	359.	6663.	233994.	347860.	1051210.

	HW-BOILE R LOAD BTU/HR	HW-BOILE R ELECTRIC USE BTU/HR	HW-BOILE R FUEL USE BTU/HR	HERM-REC -CHLR LOAD BTU/HR	HERM-REC -CHLR ELECTRIC USE BTU/HR	HERM-REC -CHLR NOM CAP RUNNING BTU/HR
	---- (1)	---- (3)	---- (4)	---- (1)	---- (3)	---- (7)
MONTHLY SUMMARY (AUG)						
MN	3904.	344.	6380.	0.	0.	0.
MX	15317.	1348.	25030.	722127.	646153.	1100000.
SM	3251140.	286100.	5312817.	143836272.	224560032.	732599936.
AV	4370.	385.	7141.	193328.	301828.	984677.
MONTHLY SUMMARY (SEP)						
MN	3904.	344.	6380.	0.	0.	0.
MX	19655.	1730.	32118.	619520.	618658.	1100000.
SM	4421954.	389132.	7226091.	84597368.	133955976.	502700000.
AV	6142.	540.	10036.	117496.	186050.	698194.
MONTHLY SUMMARY (OCT)						
MN	3904.	344.	6380.	0.	0.	0.
MX	306686.	26988.	501167.	328589.	522238.	1100000.
SM	39350464.	3462841.	64304156.	17702580.	32017160.	227700000.
AV	52890.	4654.	86430.	23794.	43034.	306048.
MONTHLY SUMMARY (NOV)						
MN	3904.	344.	6380.	0.	0.	0.
MX	363067.	31950.	593303.	29304.	52889.	1100000.
SM	114868680.	10108443.	187711472.	4434096.	8004439.	301400000.
AV	159540.	14040.	260710.	6158.	11117.	418611.
MONTHLY SUMMARY (DEC)						
MN	42710.	3758.	69794.	0.	0.	0.
MX	507259.	39600.	803684.	36366.	65628.	1100000.
SM	192135872.	16843426.	313654464.	5206488.	9398716.	353100000.
AV	258247.	22639.	421579.	6998.	12633.	474597.
YEARLY SUMMARY						
MN	3904.	344.	6380.	0.	0.	0.
MX	589886.	39600.	901638.	768800.	647953.	1100000.
SM	975085632.	84934968.	1589046528.	603661440.	946750848.	5206300160.
AV	111311.	9696.	181398.	68911.	108077.	594327.

	AHU-1	AHU-1	AHU-1	AHU-1	AHU-1	AHU-2	AHU-2	AHU-2
	TOT HTG COIL PWR BTU/HR	TOT CLG COIL PWR BTU/HR	SUPPLY ELECTRIC KW	COOLING CAPACITY BTU/HR	HEATING CAPACITY BTU/HR	TOT HTG COIL PWR BTU/HR	TOT CLG COIL PWR BTU/HR	SUPPLY ELECTRIC KW
	----(5)	----(6)	----(49)	----(70)	----(78)	----(5)	----(6)	----(49)
MONTHLY SUMMARY (AUG)								
MN	0.	0.	0.000	0.	0.	0.	0.	0.000
MK	0.	106919.	1.622	143494.	0.	0.	107361.	1.630
SM	0.	10404529.	361.795	21234902.	0.	0.	10410859.	361.904
AV	0.	13985.	0.486	28542.	0.	0.	13993.	0.486
MONTHLY SUMMARY (SEP)								
MN	0.	0.	0.000	0.	0.	0.	0.	0.000
MK	0.	93269.	1.622	155795.	0.	0.	93485.	1.630
SM	0.	8185327.	339.082	16891336.	0.	0.	8168650.	340.712
AV	0.	11369.	0.471	23460.	0.	0.	11345.	0.473
MONTHLY SUMMARY (OCT)								
MN	-33093.	0.	0.000	0.	-117423.	-33598.	0.	0.000
MK	0.	61041.	1.622	125504.	0.	0.	60994.	1.630
SM	-279692.	2142264.	407.222	15404872.	-9159013.	-284719.	2122945.	409.180
AV	-376.	2879.	0.547	20705.	-12311.	-383.	2853.	0.550
MONTHLY SUMMARY (NOV)								
MN	-66538.	0.	0.000	0.	-117423.	-67155.	0.	0.000
MK	0.	0.	1.622	117235.	0.	0.	0.	1.630
SM	-1968734.	0.	270.941	9818332.	-19609682.	-2015934.	0.	273.874
AV	-2734.	0.	0.376	13637.	-27236.	-2800.	0.	0.380
MONTHLY SUMMARY (DEC)								
MN	-82198.	0.	0.000	0.	-117423.	-82910.	0.	0.000
MK	0.	0.	1.622	59903.	0.	0.	0.	1.630
SM	-6598455.	0.	438.048	14552241.	-31704274.	-6738382.	0.	445.045
AV	-8869.	0.	0.589	19559.	-42613.	-9057.	0.	0.598
YEARLY SUMMARY								
MN	-100728.	0.	0.000	0.	-117423.	-101606.	0.	0.000
MK	0.	106919.	1.622	155795.	0.	0.	107361.	1.630
SM	-28405758.	47147844.	4515.139	190587216.	-166975856.	-28902964.	47127600.	4544.997
AV	-3243.	5382.	0.515	21757.	-19061.	-3299.	5380.	0.519

MDDH	AHU-2	AHU-2	AHU-3	AHU-3	AHU-3	AHU-3	AHU-3	AHU-4
	COOLING CAPACITY BTU/HR	HEATING CAPACITY BTU/HR	TOT HTG COIL PWR BTU/HR	TOT CLG COIL PWR BTU/HR	SUPPLY ELECTRIC KW	COOLING CAPACITY BTU/HR	HEATING CAPACITY BTU/HR	TOT HTG COIL PWR BTU/HR
	---- (70)	---- (78)	---- (5)	---- (6)	---- (49)	---- (70)	---- (78)	---- (5)
MONTHLY SUMMARY (JAN)								
MN	0.	-117988.	-62326.	0.	0.000	0.	-78470.	-37937.
MX	72330.	0.	0.	0.	1.084	50451.	0.	0.
SM	14764946.	-32092664.	-11262320.	0.	429.343	14425893.	-31074254.	-5769445.
AV	19845.	-43135.	-15138.	0.	0.577	19390.	-41766.	-7755.
MONTHLY SUMMARY (FEB)								
MN	0.	-117988.	-73404.	0.	0.000	0.	-78470.	-46628.
MX	54097.	0.	0.	0.	1.084	38136.	0.	0.
SM	13524269.	-29496934.	-9648173.	0.	384.891	12884698.	-27856964.	-5025702.
AV	20125.	-43894.	-14357.	0.	0.573	19174.	-41454.	-7479.
MONTHLY SUMMARY (MAR)								
MN	0.	-117988.	-53666.	0.	0.000	0.	-78470.	-33548.
MX	88238.	0.	0.	0.	1.084	63862.	0.	0.
SM	11335545.	-24305472.	-5963777.	0.	366.460	12426867.	-26522970.	-2929712.
AV	15236.	-32669.	-8016.	0.	0.493	16703.	-35649.	-3938.
MONTHLY SUMMARY (APR)								
MN	0.	-117988.	-46028.	0.	0.000	0.	-78470.	-27989.
MX	111675.	0.	0.	0.	1.084	78532.	0.	0.
SM	11413925.	-21473768.	-2309906.	0.	268.882	10023690.	-19460640.	-958857.
AV	15853.	-29825.	-3208.	0.	0.373	13922.	-27029.	-1332.
MONTHLY SUMMARY (MAY)								
MN	0.	0.	0.	0.	0.000	0.	0.	0.
MX	107302.	0.	0.	43083.	1.084	111569.	0.	0.
SM	18671246.	0.	0.	2000144.	556.195	21779054.	0.	0.
AV	25096.	0.	0.	2688.	0.748	29273.	0.	0.
MONTHLY SUMMARY (JUN)								
MN	0.	0.	0.	0.	0.000	0.	0.	0.
MX	131247.	0.	0.	69810.	1.084	94899.	0.	0.
SM	19114086.	0.	0.	5001625.	294.902	15479261.	0.	0.
AV	26547.	0.	0.	6947.	0.410	21499.	0.	0.
MONTHLY SUMMARY (JUL)								
MN	0.	0.	0.	0.	0.000	0.	0.	0.
MX	155726.	0.	0.	68394.	1.084	111327.	0.	0.
SM	24370208.	0.	0.	7640112.	261.292	15948613.	0.	0.
AV	32756.	0.	0.	10269.	0.351	21436.	0.	0.

	AHU-2	AHU-2	AHU-3	AHU-3	AHU-3	AHU-3	AHU-3	AHU-4
	COOLING CAPACITY BTU/HR	HEATING CAPACITY BTU/HR	TOT HTG COIL PWR BTU/HR	TOT CLG COIL PWR BTU/HR	SUPPLY ELECTRIC KW	COOLING CAPACITY BTU/HR	HEATING CAPACITY BTU/HR	TOT HTG COIL PWR BTU/HR
	----(70)	----(78)	----(5)	----(6)	----(49)	----(70)	----(78)	----(5)
MONTHLY SUMMARY (AUG)								
MN	0.	0.	0.	0.	0.000	0.	0.	0.
MX	144281.	0.	0.	70974.	1.084	101411.	0.	0.
SM	21225248.	0.	0.	5748292.	232.019	13067410.	0.	0.
AV	28529.	0.	0.	7726.	0.312	17564.	0.	0.
MONTHLY SUMMARY (SEP)								
MN	0.	0.	0.	0.	0.000	0.	0.	0.
MX	156953.	0.	0.	65945.	1.084	111994.	0.	0.
SM	16891610.	0.	0.	4463302.	370.796	16159113.	0.	0.
AV	23461.	0.	0.	6199.	0.515	22443.	0.	0.
MONTHLY SUMMARY (OCT)								
MN	0.	-117988.	-33395.	0.	0.000	0.	-78470.	-22591.
MX	126610.	0.	0.	29792.	1.084	86595.	0.	0.
SM	15468260.	-9203044.	-581519.	677277.	397.901	15184314.	-6983858.	-272060.
AV	20791.	-12370.	-782.	910.	0.535	20409.	-9387.	-366.
MONTHLY SUMMARY (NOV)								
MN	0.	-117988.	-47627.	0.	0.000	0.	-78470.	-31003.
MX	117314.	0.	0.	0.	1.084	84908.	0.	0.
SM	9904998.	-19821942.	-4216694.	0.	308.997	10945988.	-22364042.	-2036772.
AV	13757.	-27530.	-5857.	0.	0.429	15203.	-31061.	-2829.
MONTHLY SUMMARY (DEC)								
MN	0.	-117988.	-64783.	0.	0.000	0.	-78470.	-40808.
MX	60004.	0.	0.	0.	1.084	44760.	0.	0.
SM	14779087.	-32210650.	-9964314.	0.	438.017	14691341.	-31702012.	-4993816.
AV	19864.	-43294.	-13393.	0.	0.589	19746.	-42610.	-6712.
YEARLY SUMMARY								
MN	0.	-117988.	-73404.	0.	0.000	0.	-78470.	-46628.
MX	156953.	0.	0.	70974.	1.084	111994.	0.	0.
SM	191463424.	-168604480.	-43946696.	25530750.	4309.695	173016256.	-165964736.	-21986364.
AV	21857.	-19247.	-5017.	2914.	0.492	19751.	-18946.	-2510.

MDDHH	AHU-4	AHU-4	AHU-4	AHU-4	AHU-5	AHU-5	AHU-5	AHU-5
	TOT CLG COIL PWR BTU/HR	SUPPLY ELECTRIC KW	COOLING CAPACITY BTU/HR	HEATING CAPACITY BTU/HR	TOT HTG COIL PWR BTU/HR	TOT CLG COIL PWR BTU/HR	SUPPLY ELECTRIC KW	COOLING CAPACITY BTU/HR
	---- (6)	----(49)	----(70)	----(78)	---- (5)	---- (6)	----(49)	----(70)
MONTHLY SUMMARY (JAN)								
MN	0.	0.000	0.	-53066.	-101306.	0.	0.000	0.
MX	0.	0.733	34473.	0.	0.	0.	1.521	56140.
SM	0.	255.887	8589483.	-18520124.	-19246988.	0.	585.585	19163360.
AV	0.	0.344	11545.	-24893.	-25870.	0.	0.787	25757.
MONTHLY SUMMARY (FEB)								
MN	0.	0.000	0.	-53066.	-110091.	0.	0.000	0.
MX	0.	0.733	25300.	0.	0.	0.	1.521	49739.
SM	0.	232.424	7771643.	-16822002.	-16428174.	0.	530.829	17358824.
AV	0.	0.346	11565.	-25033.	-24447.	0.	0.790	25832.
MONTHLY SUMMARY (MAR)								
MN	0.	0.000	0.	-53066.	-91581.	0.	0.000	0.
MX	0.	0.733	42738.	0.	0.	0.	1.521	69869.
SM	0.	214.094	7265918.	-15495346.	-10622980.	0.	498.888	16378697.
AV	0.	0.288	9766.	-20827.	-14278.	0.	0.671	22014.
MONTHLY SUMMARY (APR)								
MN	0.	0.000	0.	-53066.	-77244.	0.	0.000	0.
MX	0.	0.733	53150.	0.	0.	0.	1.521	86313.
SM	0.	145.174	5575154.	-10507119.	-4307575.	0.	358.956	12394941.
AV	0.	0.202	7743.	-14593.	-5983.	0.	0.499	17215.
MONTHLY SUMMARY (MAY)								
MN	0.	0.000	0.	0.	0.	0.	0.000	0.
MX	30173.	0.733	74040.	0.	0.	52932.	1.521	132494.
SM	1583633.	298.412	11713840.	0.	0.	2100258.	790.920	29356308.
AV	2129.	0.401	15744.	0.	0.	2823.	1.063	39457.
MONTHLY SUMMARY (JUN)								
MN	0.	0.000	0.	0.	0.	0.	0.000	0.
MX	48231.	0.733	61419.	0.	0.	94326.	1.521	120336.
SM	3812462.	175.968	9450779.	0.	0.	6308503.	375.687	18695764.
AV	5295.	0.244	13126.	0.	0.	8762.	0.522	25966.
MONTHLY SUMMARY (JUL)								
MN	0.	0.000	0.	0.	0.	0.	0.000	0.
MX	46425.	0.733	74126.	0.	0.	89723.	1.521	143103.
SM	5528693.	182.567	11110509.	0.	0.	9969372.	333.099	18666004.
AV	7431.	0.245	14933.	0.	0.	13400.	0.448	25089.

	AHU-4	AHU-4	AHU-4	AHU-4	AHU-5	AHU-5	AHU-5	AHU-5
	TOT CLG COIL PWR BTU/HR	SUPPLY ELECTRIC KW	COOLING CAPACITY BTU/HR	HEATING CAPACITY BTU/HR	TOT HTG COIL PWR BTU/HR	TOT CLG COIL PWR BTU/HR	SUPPLY ELECTRIC KW	COOLING CAPACITY BTU/HR
	---- (6)	----(49)	----(70)	----(78)	---- (5)	---- (6)	----(49)	----(70)
MONTHLY SUMMARY (AUG)								
MN	0.	0.000	0.	0.	0.	0.	0.000	0.
MX	48889.	0.733	67109.	0.	0.	95537.	1.521	133195.
SM	4263822.	145.907	8607648.	0.	0.	7188795.	301.158	15438603.
AV	5731.	0.196	11569.	0.	0.	9662.	0.405	20751.
MONTHLY SUMMARY (SEP)								
MN	0.	0.000	0.	0.	0.	0.	0.000	0.
MX	43906.	0.733	73238.	0.	0.	84268.	1.521	141299.
SM	3205502.	190.632	8797278.	0.	0.	5281770.	587.106	23791318.
AV	4452.	0.265	12218.	0.	0.	7336.	0.815	33043.
MONTHLY SUMMARY (OCT)								
MN	0.	0.000	0.	-53066.	-63669.	0.	0.000	0.
MX	21331.	0.733	57896.	0.	0.	23574.	1.521	117427.
SM	573053.	238.290	9128522.	-4245301.	-1436415.	221212.	650.988	23705792.
AV	770.	0.320	12270.	-5706.	-1931.	297.	0.875	31863.
MONTHLY SUMMARY (NOV)								
MN	0.	0.000	0.	-53066.	-85187.	0.	0.000	0.
MX	0.	0.733	56212.	0.	0.	0.	1.521	93258.
SM	0.	175.235	6260747.	-12682835.	-7815794.	0.	430.443	14473922.
AV	0.	0.243	8695.	-17615.	-10855.	0.	0.598	20103.
MONTHLY SUMMARY (DEC)								
MN	0.	0.000	0.	-53066.	-106514.	0.	0.000	0.
MX	0.	0.733	29417.	0.	0.	0.	1.521	51314.
SM	0.	259.553	8692954.	-18785454.	-17202880.	0.	594.711	19449432.
AV	0.	0.349	11684.	-25249.	-23122.	0.	0.799	26142.
YEARLY SUMMARY								
MN	0.	0.000	0.	-53066.	-110091.	0.	0.000	0.
MX	48889.	0.733	74126.	0.	0.	95537.	1.521	143103.
SM	18967166.	2514.143	102964472.	-97058184.	-77060800.	31069908.	6038.370	228872960.
AV	2165.	0.287	11754.	-11080.	-8797.	3547.	0.689	26127.

MMDHHR	AHU-5	AHU-6	AHU-6	AHU-6	AHU-6	AHU-6	AHU-7	AHU-7
	HEATING CAPACITY BTU/HR	TOT HTG COIL PWR BTU/HR	TOT CLG COIL PWR BTU/HR	SUPPLY ELECTRIC KW	COOLING CAPACITY BTU/HR	HEATING CAPACITY BTU/HR	TOT HTG COIL PWR BTU/HR	TOT CLG COIL PWR BTU/HR
	----(78)	----(5)	----(6)	----(49)	----(70)	----(78)	----(5)	----(6)
MONTHLY SUMMARY (JAN)								
MN	-110084.	-55507.	0.	0.000	0.	-62099.	-42967.	0.
MX	0.	0.	0.	0.858	35397.	0.	0.	0.
SM	-42382444.	-8903135.	0.	312.312	10349675.	-22603972.	-3823111.	0.
AV	-56966.	-11967.	0.	0.420	13911.	-30382.	-5139.	0.
MONTHLY SUMMARY (FEB)								
MN	-110084.	-60946.	0.	0.000	0.	-62099.	-57215.	0.
MX	0.	0.	0.	0.858	28374.	0.	0.	0.
SM	-38419412.	-7642227.	0.	283.998	9391930.	-20554710.	-3745498.	0.
AV	-57172.	-11372.	0.	0.423	13976.	-30587.	-5574.	0.
MONTHLY SUMMARY (MAR)								
MN	-110084.	-45549.	0.	0.000	0.	-62099.	-37472.	0.
MX	0.	0.	0.	0.858	44447.	0.	0.	0.
SM	-36107640.	-4825221.	0.	265.980	8866629.	-19250634.	-1565923.	0.
AV	-48532.	-6486.	0.	0.358	11918.	-25875.	-2105.	0.
MONTHLY SUMMARY (APR)								
MN	-110084.	-38638.	0.	0.000	0.	-62099.	-28421.	0.
MX	0.	0.	0.	0.858	55729.	0.	0.	0.
SM	-25979888.	-1853258.	0.	189.618	6839209.	-13723841.	-467966.	0.
AV	-36083.	-2574.	0.	0.263	9499.	-19061.	-650.	0.
MONTHLY SUMMARY (MAY)								
MN	0.	0.	0.	0.000	0.	0.	0.	0.
MX	0.	0.	32153.	0.858	81396.	0.	0.	48954.
SM	0.	0.	1396395.	430.716	16387062.	0.	0.	3193276.
AV	0.	0.	1877.	0.579	22026.	0.	0.	4292.
MONTHLY SUMMARY (JUN)								
MN	0.	0.	0.	0.000	0.	0.	0.	0.
MX	0.	0.	54697.	0.858	74751.	0.	0.	69879.
SM	0.	0.	3835972.	201.630	10271409.	0.	0.	6493706.
AV	0.	0.	5328.	0.280	14266.	0.	0.	9019.
MONTHLY SUMMARY (JUL)								
MN	0.	0.	0.	0.000	0.	0.	0.	0.
MX	0.	0.	52211.	0.858	81023.	0.	0.	69282.
SM	0.	0.	5799415.	189.618	10872045.	0.	0.	8577917.
AV	0.	0.	7795.	0.255	14613.	0.	0.	11529.

	AHU-5	AHU-6	AHU-6	AHU-6	AHU-6	AHU-6	AHU-7	AHU-7
	HEATING CAPACITY BTU/HR	TOT HTG COIL PWR BTU/HR	TOT CLG COIL PWR BTU/HR	SUPPLY ELECTRIC KW	COOLING CAPACITY BTU/HR	HEATING CAPACITY BTU/HR	TOT HTG COIL PWR BTU/HR	TOT CLG COIL PWR BTU/HR
	----(78)	----(5)	----(6)	----(49)	----(70)	----(78)	----(5)	----(6)
MONTHLY SUMMARY (AUG)								
MN	0.	0.	0.	0.000	0.	0.	0.	0.
MX	0.	0.	55087.	0.858	75493.	0.	0.	70554.
SM	0.	0.	4219691.	161.304	8577449.	0.	0.	7059080.
AV	0.	0.	5672.	0.217	11529.	0.	0.	9488.
MONTHLY SUMMARY (SEP)								
MN	0.	0.	0.	0.000	0.	0.	0.	0.
MX	0.	0.	48246.	0.858	78120.	0.	0.	62710.
SM	0.	0.	3167384.	306.306	12851039.	0.	0.	5709374.
AV	0.	0.	4399.	0.425	17849.	0.	0.	7930.
MONTHLY SUMMARY (OCT)								
MN	-110084.	-33687.	0.	0.000	0.	-62099.	-17733.	0.
MX	0.	0.	17362.	0.858	69333.	0.	0.	43326.
SM	-10678173.	-583388.	261620.	336.336	12500655.	-5464696.	-135729.	1905568.
AV	-14352.	-784.	352.	0.452	16802.	-7345.	-182.	2561.
MONTHLY SUMMARY (NOV)								
MN	-110084.	-43659.	0.	0.000	0.	-62099.	-37217.	0.
MX	0.	0.	0.	0.858	59177.	0.	0.	0.
SM	-31153850.	-3453006.	0.	224.796	7766764.	-16269891.	-848013.	0.
AV	-43269.	-4796.	0.	0.312	10787.	-22597.	-1178.	0.
MONTHLY SUMMARY (DEC)								
MN	-110084.	-58689.	0.	0.000	0.	-62099.	-47116.	0.
MX	0.	0.	0.	0.858	31883.	0.	0.	0.
SM	-43042952.	-7834295.	0.	314.028	10391632.	-22728168.	-3191009.	0.
AV	-57853.	-10530.	0.	0.422	13967.	-30549.	-4289.	0.
YEARLY SUMMARY								
MN	-110084.	-60946.	0.	0.000	0.	-62099.	-57215.	0.
MX	0.	0.	55087.	0.858	81396.	0.	0.	70554.
SM	-227764352.	-35094532.	18680476.	3216.642	125065496.	-120595904.	-13777248.	32938922.
AV	-26000.	-4006.	2132.	0.367	14277.	-13767.	-1573.	3760.

MMDDHH	AHU-7	AHU-7	AHU-7	AHU-8	AHU-8	AHU-8	AHU-8	AHU-8
	SUPPLY ELECTRIC KW	COOLING CAPACITY BTU/HR	HEATING CAPACITY BTU/HR	TOT HTG COIL PWR BTU/HR	TOT CLG COIL PWR BTU/HR	SUPPLY ELECTRIC KW	COOLING CAPACITY BTU/HR	HEATING CAPACITY BTU/HR
	---- (49)	---- (70)	---- (78)	---- (5)	---- (6)	---- (49)	---- (70)	---- (78)
MONTHLY SUMMARY (JAN)								
MN	0.000	0.	-75648.	-191323.	0.	0.000	0.	-235411.
MX	1.045	55052.	0.	0.	0.	3.253	103358.	0.
SM	263.390	8918676.	-19063208.	-37149004.	0.	1372.597	43575172.	-99343416.
AV	0.354	11987.	-25623.	-49931.	0.	1.845	58569.	-133526.
MONTHLY SUMMARY (FEB)								
MN	0.000	0.	-75648.	-222252.	0.	0.000	0.	-235411.
MX	1.045	38603.	0.	0.	0.	3.253	103258.	0.
SM	247.712	8316832.	-17928490.	-30048776.	0.	1206.715	38308896.	-87337464.
AV	0.369	12376.	-26679.	-44715.	0.	1.796	57007.	-129966.
MONTHLY SUMMARY (MAR)								
MN	0.000	0.	-75648.	-154162.	0.	0.000	0.	-235411.
MX	1.045	66893.	0.	0.	0.	3.253	124961.	0.
SM	196.498	6845373.	-14221755.	-18031228.	0.	1070.106	34054624.	-77450200.
AV	0.264	9201.	-19115.	-24236.	0.	1.438	45772.	-104100.
MONTHLY SUMMARY (APR)								
MN	0.000	0.	-75648.	-135746.	0.	0.000	0.	-235411.
MX	1.045	82150.	0.	0.	0.	3.253	160167.	0.
SM	194.407	8106791.	-14070460.	-6739258.	0.	725.330	24065356.	-52496652.
AV	0.270	11259.	-19542.	-9360.	0.	1.007	33424.	-72912.
MONTHLY SUMMARY (MAY)								
MN	0.000	0.	0.	0.	0.	0.000	0.	0.
MX	1.045	72786.	0.	0.	106968.	3.253	193468.	0.
SM	301.018	12527937.	0.	0.	5538224.	1483.186	52684760.	0.
AV	0.405	16839.	0.	0.	7444.	1.994	70813.	0.
MONTHLY SUMMARY (JUN)								
MN	0.000	0.	0.	0.	0.	0.000	0.	0.
MX	1.045	89213.	0.	0.	183757.	3.253	241000.	0.
SM	240.396	13493976.	0.	0.	16062465.	865.192	43629868.	0.
AV	0.334	18742.	0.	0.	22309.	1.202	60597.	0.
MONTHLY SUMMARY (JUL)								
MN	0.000	0.	0.	0.	0.	0.000	0.	0.
MX	1.045	105977.	0.	0.	179477.	3.253	298603.	0.
SM	286.385	17614974.	0.	0.	23357528.	923.739	51307064.	0.
AV	0.385	23676.	0.	0.	31395.	1.242	68961.	0.

	AHU-7	AHU-7	AHU-7	AHU-8	AHU-8	AHU-8	AHU-8	AHU-8
	SUPPLY ELECTRIC KW	COOLING CAPACITY BTU/HR	HEATING CAPACITY BTU/HR	TOT HTG COIL PWR BTU/HR	TOT CLG COIL PWR BTU/HR	SUPPLY ELECTRIC KW	COOLING CAPACITY BTU/HR	HEATING CAPACITY BTU/HR
	----(49)	----(70)	----(78)	----(5)	----(6)	----(49)	----(70)	----(78)
MONTHLY SUMMARY (AUG)								
MN	0.000	0.	0.	0.	0.	0.000	0.	0.
MX	1.045	94128.	0.	0.	185088.	3.253	262322.	0.
SM	251.893	15277671.	0.	0.	17663684.	842.424	45409860.	0.
AV	0.339	20535.	0.	0.	23742.	1.132	61035.	0.
MONTHLY SUMMARY (SEP)								
MN	0.000	0.	0.	0.	0.	0.000	0.	0.
MX	1.045	106312.	0.	0.	156352.	3.253	265991.	0.
SM	230.989	12077680.	0.	0.	10835095.	1161.178	46362092.	0.
AV	0.321	16775.	0.	0.	15049.	1.613	64392.	0.
MONTHLY SUMMARY (OCT)								
MN	0.000	0.	-75648.	-115128.	0.	0.000	0.	-235411.
MX	1.045	78396.	0.	0.	62356.	3.253	208638.	0.
SM	243.532	9663458.	-6127460.	-2675412.	1116595.	1343.324	46218912.	-24247330.
AV	0.327	12989.	-8236.	-3596.	1501.	1.806	62122.	-32590.
MONTHLY SUMMARY (NOV)								
MN	0.000	0.	-75648.	-135867.	0.	0.000	0.	-235411.
MX	1.045	85405.	0.	0.	0.	3.253	165999.	0.
SM	162.006	6233665.	-11725385.	-14521933.	0.	975.780	31452340.	-70623288.
AV	0.225	8658.	-16285.	-20169.	0.	1.355	43684.	-98088.
MONTHLY SUMMARY (DEC)								
MN	0.000	0.	-75648.	-195736.	0.	0.000	0.	-235411.
MX	1.045	43320.	0.	0.	0.	3.253	103258.	0.
SM	268.616	9047300.	-19441444.	-33409934.	0.	1401.871	44504404.	-101462120.
AV	0.361	12160.	-26131.	-44906.	0.	1.884	59818.	-136374.
YEARLY SUMMARY								
MN	0.000	0.	-75648.	-222252.	0.	0.000	0.	-235411.
MX	1.045	106312.	0.	0.	185088.	3.253	298603.	0.
SM	2886.843	128124336.	-102578192.	-142575552.	74573584.	13371.442	501573344.	-512960448.
AV	0.330	14626.	-11710.	-16276.	8513.	1.526	57257.	-58557.

MMDDHH	AHU-9	AHU-9	AHU-9	AHU-9	AHU-9
	TOT HTG COIL PWR BTU/HR	TOT CLG COIL PWR BTU/HR	SUPPLY ELECTRIC KW	COOLING CAPACITY BTU/HR	HEATING CAPACITY BTU/HR
	----(5)	----(6)	----(49)	----(70)	----(78)
MONTHLY SUMMARY (JAN)					
MN	-36694.	0.	0.000	0.	-45727.
MX	0.	0.	0.632	19159.	0.
SM	-3257873.	0.	155.423	4713114.	-11248918.
AV	-4379.	0.	0.209	6335.	-15120.
MONTHLY SUMMARY (FEB)					
MN	-43374.	0.	0.000	0.	-45727.
MX	0.	0.	0.632	19159.	0.
SM	-3038772.	0.	141.523	4291616.	-10242917.
AV	-4522.	0.	0.211	6386.	-15242.
MONTHLY SUMMARY (MAR)					
MN	-30890.	0.	0.000	0.	-45727.
MX	0.	0.	0.632	20837.	0.
SM	-1416794.	0.	114.988	3494788.	-8322370.
AV	-1904.	0.	0.155	4697.	-11186.
MONTHLY SUMMARY (APR)					
MN	-20140.	0.	0.000	0.	-45727.
MX	0.	0.	0.632	24905.	0.
SM	-402227.	0.	114.988	3645020.	-8322370.
AV	-559.	0.	0.160	5063.	-11559.
MONTHLY SUMMARY (MAY)					
MN	0.	0.	0.000	0.	0.
MX	0.	22506.	0.632	29363.	0.
SM	0.	1467154.	153.527	5302886.	0.
AV	0.	1972.	0.206	7128.	0.
MONTHLY SUMMARY (JUN)					
MN	0.	0.	0.000	0.	0.
MX	0.	34409.	0.632	44227.	0.
SM	0.	3604856.	133.942	6186331.	0.
AV	0.	5007.	0.186	8592.	0.
MONTHLY SUMMARY (JUL)					
MN	0.	0.	0.000	0.	0.
MX	0.	33686.	0.632	52759.	0.
SM	0.	4785696.	160.477	8019617.	0.
AV	0.	6432.	0.216	10779.	0.

	AHU-9	AHU-9	AHU-9	AHU-9	AHU-9
	TOT HTG COIL PWR BTU/HR	TOT CLG COIL PWR BTU/HR	SUPPLY ELECTRIC KW	COOLING CAPACITY BTU/HR	HEATING CAPACITY BTU/HR
	---- (5)	---- (6)	---- (49)	---- (70)	---- (78)
MONTHLY SUMMARY (AUG)					
MN	0.	0.	0.000	0.	0.
MX	0.	34907.	0.632	46432.	0.
SM	0.	3948597.	138.364	6857717.	0.
AV	0.	5307.	0.186	9217.	0.
MONTHLY SUMMARY (SEP)					
MN	0.	0.	0.000	0.	0.
MX	0.	30604.	0.632	42444.	0.
SM	0.	3038145.	125.096	5243824.	0.
AV	0.	4220.	0.174	7283.	0.
MONTHLY SUMMARY (OCT)					
MN	-12641.	0.	0.000	0.	-45727.
MX	0.	18053.	0.632	26268.	0.
SM	-88779.	607161.	142.155	4572612.	-3566730.
AV	-119.	816.	0.191	6146.	-4794.
MONTHLY SUMMARY (NOV)					
MN	-31433.	0.	0.000	0.	-45727.
MX	0.	0.	0.632	26424.	0.
SM	-709144.	0.	90.347	2810623.	-6539005.
AV	-985.	0.	0.125	3904.	-9082.
MONTHLY SUMMARY (DEC)					
MN	-39616.	0.	0.000	0.	-45727.
MX	0.	0.	0.632	19159.	0.
SM	-2919440.	0.	159.214	4828068.	-11523281.
AV	-3924.	0.	0.214	6489.	-15488.
YEARLY SUMMARY					
MN	-43374.	0.	0.000	0.	-45727.
MX	0.	34907.	0.632	52759.	0.
SM	-11833028.	17451610.	1630.044	59966212.	-59765588.
AV	-1351.	1992.	0.186	6845.	-6823.

MDDHH	FC-1	FC-1	FC-1	FC-1	FC-1
	TOT HTG COIL PWR BTU/HR	TOT CLG COIL PWR BTU/HR	SUPPLY ELECTRIC KW	COOLING CAPACITY BTU/HR	HEATING CAPACITY BTU/HR
	---- (5)	---- (6)	----(49)	----(70)	----(78)
MONTHLY SUMMARY (JAN)					
MN	0.	0.	0.090	27201.	0.
MX	0.	10466.	0.090	42494.	0.
SM	0.	77529.	15.261	5385306.	0.
AV	0.	459.	0.090	31866.	0.
MONTHLY SUMMARY (FEB)					
MN	0.	0.	0.090	27160.	0.
MX	0.	9732.	0.090	45690.	0.
SM	0.	78723.	14.087	5062898.	0.
AV	0.	505.	0.090	32454.	0.
MONTHLY SUMMARY (MAR)					
MN	0.	0.	0.090	27154.	0.
MX	0.	10301.	0.090	34784.	0.
SM	0.	150055.	15.261	4834560.	0.
AV	0.	888.	0.090	28607.	0.
MONTHLY SUMMARY (APR)					
MN	0.	0.	0.090	27154.	0.
MX	0.	8784.	0.090	32311.	0.
SM	0.	137581.	16.435	5139746.	0.
AV	0.	756.	0.090	28240.	0.
MONTHLY SUMMARY (MAY)					
MN	0.	0.	0.090	27787.	0.
MX	0.	0.	0.090	60753.	0.
SM	0.	0.	14.087	6307047.	0.
AV	0.	0.	0.090	40430.	0.
MONTHLY SUMMARY (JUN)					
MN	0.	0.	0.090	30416.	0.
MX	0.	0.	0.090	90865.	0.
SM	0.	0.	15.261	9000268.	0.
AV	0.	0.	0.090	53256.	0.
MONTHLY SUMMARY (JUL)					
MN	0.	0.	0.090	35928.	0.
MX	0.	0.	0.090	94810.	0.
SM	0.	0.	16.435	11180861.	0.
AV	0.	0.	0.090	61433.	0.

	FC-1	FC-1	FC-1	FC-1	FC-1
	TOT HTG COIL PWR BTU/HR	TOT CLG COIL PWR BTU/HR	SUPPLY ELECTRIC KW	COOLING CAPACITY BTU/HR	HEATING CAPACITY BTU/HR
	---- (5)	---- (6)	----(49)	----(70)	----(78)
MONTHLY SUMMARY (AUG)					
MN	0.	0.	0.090	30021.	0.
MX	0.	0.	0.090	85751.	0.
SM	0.	0.	14.087	9500860.	0.
AV	0.	0.	0.090	60903.	0.
MONTHLY SUMMARY (SEP)					
MN	0.	0.	0.090	28132.	0.
MX	0.	0.	0.090	84977.	0.
SM	0.	0.	16.435	8997871.	0.
AV	0.	0.	0.090	49439.	0.
MONTHLY SUMMARY (OCT)					
MN	0.	0.	0.090	27154.	0.
MX	0.	2035.	0.090	49013.	0.
SM	0.	2035.	15.261	5443836.	0.
AV	0.	12.	0.090	32212.	0.
MONTHLY SUMMARY (NOV)					
MN	0.	0.	0.090	27154.	0.
MX	0.	14220.	0.090	35687.	0.
SM	0.	139245.	11.739	3678808.	0.
AV	0.	1071.	0.090	28299.	0.
MONTHLY SUMMARY (DEC)					
MN	0.	0.	0.090	27365.	0.
MX	0.	5604.	0.090	40812.	0.
SM	0.	53520.	17.609	5916533.	0.
AV	0.	274.	0.090	30341.	0.
YEARLY SUMMARY					
MN	0.	0.	0.090	27154.	0.
MX	0.	14220.	0.090	94810.	0.
SM	0.	638689.	181.955	80448592.	0.
AV	0.	317.	0.090	39925.	0.

S I T E E N E R G Y													
	2	3	4	5	6	7	8	9	10	11	12	13	14
MONTH	TOTAL HEAT LOAD	TOTAL COOLING LOAD	TOTAL ELECTR LOAD	RCVRED ENERGY	WASTED RCVRABL ENERGY	FUEL INPUT COOLING	ELEC INPUT COOLING	FUEL INPUT HEATING	ELEC INPUT HEATING	FUEL INPUT ELECT	TOTAL FUEL INPUT	TOTAL SITE ENERGY	TOTAL SOURCE ENERGY
JAN	110.7	5.0	58.6 17.2E	0.0	0.0	0.0	11.7 3.4E	179.8	11.8 3.5E	0.0	179.8	238.5	355.9
FEB	94.8	5.3	53.8 15.8E	0.0	0.0	0.0	12.2 3.6E	152.8	10.0 2.9E	0.0	152.8	206.6	314.4
MAR	56.5	4.4	49.0 14.3E	0.0	0.0	0.0	10.2 3.0E	92.0	7.2 2.1E	0.0	92.0	141.0	239.1
APR	23.1	2.9	40.0 11.7E	0.0	0.0	0.0	6.8 2.0E	37.6	4.2 1.2E	0.0	37.6	77.7	157.9
MAY	6.0	27.9	85.3 25.0E	0.0	0.0	0.0	45.8 13.4E	9.9	2.8 0.8E	0.0	9.9	95.2	266.1
JUN	4.1	68.7	131.9 38.6E	0.0	0.0	0.0	99.5 29.1E	6.7	2.6 0.7E	0.0	6.7	138.5	402.7
JUL	4.2	97.0	168.0 49.2E	0.0	0.0	0.0	133.5 39.1E	6.9	2.6 0.8E	0.0	6.9	174.9	511.5
AUG	4.2	75.9	136.9 40.1E	0.0	0.0	0.0	105.4 30.9E	6.8	2.6 0.8E	0.0	6.8	143.7	417.9
SEP	4.3	55.5	113.3 33.2E	0.0	0.0	0.0	78.1 22.9E	7.0	2.6 0.8E	0.0	7.0	120.3	347.2
OCT	12.5	11.5	59.8 17.5E	0.0	0.0	0.0	21.7 6.4E	20.4	3.4 1.0E	0.0	20.4	80.2	199.9
NOV	41.5	4.2	43.3 12.7E	0.0	0.0	0.0	9.7 2.8E	67.7	5.8 1.7E	0.0	67.7	111.1	197.8
DEC	97.2	5.3	59.1 17.3E	0.0	0.0	0.0	12.4 3.6E	158.2	10.7 3.1E	0.0	158.2	217.2	335.6
=====	459.1	363.6	999.0 292.6E	0.0	0.0	0.0	546.9 160.2E	745.9	66.2 19.4E	0.0	745.9	1744.9	3746.0

NOTE-- ALL ENTRIES ARE IN MBTU EXCEPT
 ENTRIES FOLLOWED BY E ARE IN MWH (THOUSANDS OF KWH)

MO	UTILITY-	ELECTRICITY	NATURAL-GAS
	TOTAL (MBTU)	58.622	179.833
JAN	PEAK (KBTU)	197.874	996.233
	DY/HR	20/11	20/ 8
	TOTAL (MBTU)	53.794	152.833
FEB	PEAK (KBTU)	197.854	1177.989
	DY/HR	4/11	3/ 8
	TOTAL (MBTU)	48.982	91.996
MAR	PEAK (KBTU)	191.383	893.258
	DY/HR	4/11	5/ 8
	TOTAL (MBTU)	40.046	37.643
APR	PEAK (KBTU)	186.906	767.416
	DY/HR	8/11	9/ 8
	TOTAL (MBTU)	85.337	9.868
MAY	PEAK (KBTU)	692.628	71.013
	DY/HR	21/17	10/ 7
	TOTAL (MBTU)	131.875	6.672
JUN	PEAK (KBTU)	777.215	24.551
	DY/HR	10/18	3/ 6
	TOTAL (MBTU)	168.040	6.862
JUL	PEAK (KBTU)	781.076	12.047
	DY/HR	9/17	2/ 3
	TOTAL (MBTU)	136.886	6.821
AUG	PEAK (KBTU)	791.483	11.840
	DY/HR	18/17	11/ 7
	TOTAL (MBTU)	113.280	7.015
SEP	PEAK (KBTU)	765.375	37.773
	DY/HR	1/17	22/ 7
	TOTAL (MBTU)	59.763	20.450
OCT	PEAK (KBTU)	656.156	645.504
	DY/HR	13/17	28/ 8
	TOTAL (MBTU)	43.319	67.744
NOV	PEAK (KBTU)	187.707	855.818
	DY/HR	25/11	25/ 8
	TOTAL (MBTU)	59.081	158.160
DEC	PEAK (KBTU)	197.493	1054.609
	DY/HR	22/11	22/ 8
	ONE YEAR	999.029	745.898
	USE/PEAK	791.483	1177.989

HEATING LOADS	MBTU SUPPLIED	PCT OF TOTAL LOAD
-----	-----	-----
HW-BOILER	459.1	100.0
	=====	=====
LOAD SATISFIED	459.1	100.0
TOTAL LOAD ON PLANT	459.1	

COOLING LOADS	MBTU SUPPLIED	PCT OF TOTAL LOAD
-----	-----	-----
HERM-REC-CHLR	363.6	100.0
	=====	=====
LOAD SATISFIED	363.6	100.0
TOTAL LOAD ON PLANT	363.6	

ELECTRICAL LOADS	MBTU SUPPLIED	PCT OF TOTAL LOAD
-----	-----	-----
ELECTRICITY	999.0	100.0
	=====	=====
LOAD SATISFIED	999.0	100.0
TOTAL LOAD ON PLANT	999.0	

ENTECH ENGINEERING
READING, PA 19603
REPORT- PS-D PLANT LOADS SATISFIED

EZDOE - ELITE SOFTWARE DEVELOPMENT INC
FT. GEORGE G. MEADE

DOE-2.1D 6/28/1996 10:19:20 PDL RUN 1
EMCS STUDY WEATHER FILE- BALTIMORE, MD

(CONTINUED)

SUMMARY OF LOADS MET

TYPE OF LOAD	TOTAL LOAD (MBTU)	LOAD SATISFIED (MBTU)	TOTAL OVERLOAD (MBTU)	PEAK OVERLOAD (MBTU)	HOURS OVERLOADED
HEATING LOADS	459.1	459.1	0.000	0.000	0
COOLING LOADS	363.6	363.6	0.000	0.000	0
ELECTRICAL LOADS	999.0	999.0	0.000	0.000	0

EQUIPMENT	AVG OPER RATIO	MAX LOAD (MBTU)	MON		SIZE OPER		SIZE OPER		SIZE OPER		SIZE OPER	
			DAY	HR	(MBTU)	HRS	(MBTU)	HRS	(MBTU)	HRS	(MBTU)	HRS
HW-BOILER	0.029	0.827	2	3	8	1.800	8760					
HERM-REC-CHLR	0.106	0.791	8	18	17	1.100	3124					

E Q U I P M E N T T O T A L S

HW-BOILER	74.7		
NOMINAL SIZE (MBTU)		1.800	
NUMBER INSTALLED		1	
FIRST COST (K\$)	52.6	52.6	
ANNUAL COST (K\$)	1.0	1.0	
CYCLICAL COST (K\$)	21.2	21.2	
-----TOTAL----- (K\$)		74.7	

HERM-REC-CHLR	30.1		
NOMINAL SIZE (MBTU)		1.100	
NUMBER INSTALLED		1	
FIRST COST (K\$)	24.2	24.2	
ANNUAL COST (K\$)	2.3	2.3	
CYCLICAL COST (K\$)	3.6	3.6	
-----TOTAL----- (K\$)		30.1	

EQUIPMENT TOTAL 104.8

ENERGY TYPE	ELECTRICITY	NATURAL-GAS
IN SITE MBTU -		
CATEGORY OF USE		
SPACE HEAT	39.55	745.86
SPACE COOL	519.96	0.00
HVAC AUX	202.31	0.00
DOM HOT WTR	0.00	0.00
AUX SOLAR	0.00	0.00
LIGHTS	230.36	0.00
VERT TRANS	0.00	0.00
MISC EQUIP	6.86	0.00
TOTAL	999.04	745.86

TOTAL SITE ENERGY 1744.93 MBTU 115.6 KBTU/SQFT-YR GROSS-AREA 115.6 KBTU/SQFT-YR NET-AREA
 TOTAL SOURCE ENERGY 3745.98 MBTU 248.1 KBTU/SQFT-YR GROSS-AREA 248.1 KBTU/SQFT-YR NET-AREA

PERCENT OF HOURS ANY SYSTEM ZONE OUTSIDE OF THROTTLING RANGE = 0.7
 PERCENT OF HOURS ANY PLANT LOAD NOT SATISFIED = 0.0

NOTE ELECTRICITY AND/OR FUEL USED TO GENERATE ELECTRICITY IS APPORTIONED BASED
 ON THE YEARLY DEMAND. ALL OTHER ENERGY TYPES ARE APPORTIONED HOURLY.

MMDDHH	HW-BOILE R LOAD BTU/HR ----(1)	HW-BOILE R ELECTRIC USE BTU/HR ----(3)	HW-BOILE R FUEL USE BTU/HR ----(4)	HERM-REC -CHLR LOAD BTU/HR ----(1)	HERM-REC -CHLR ELECTRIC USE BTU/HR ----(3)	HERM-REC -CHLR NOM CAP RUNNING BTU/HR ----(7)
MONTHLY SUMMARY (JAN)						
MN	5470.	481.	8939.	0.	0.	0.
MX	670289.	39600.	996233.	25982.	46897.	1100000.
SM	110725536.	9525215.	179833392.	4972195.	8975933.	342100000.
AV	148825.	12803.	241712.	6683.	12064.	459812.
MONTHLY SUMMARY (FEB)						
MN	5470.	481.	8939.	0.	0.	0.
MX	826509.	39600.	1177989.	29517.	53275.	1100000.
SM	94802152.	7933948.	152833008.	5250864.	9478891.	349800000.
AV	141075.	11806.	227430.	7814.	14105.	520536.
MONTHLY SUMMARY (MAR)						
MN	5470.	481.	8939.	0.	0.	0.
MX	582793.	39600.	893258.	25817.	46599.	1100000.
SM	56472388.	4912511.	91996784.	4403856.	7950712.	291500000.
AV	75904.	6603.	123652.	5919.	10686.	391801.
MONTHLY SUMMARY (APR)						
MN	5470.	481.	8939.	0.	0.	0.
MX	476825.	39600.	767416.	25939.	46819.	1100000.
SM	23054618.	2022607.	37643544.	2931812.	5296651.	189200000.
AV	32020.	2809.	52283.	4072.	7356.	262778.
MONTHLY SUMMARY (MAY)						
MN	5470.	481.	8939.	0.	0.	0.
MX	43456.	3824.	71013.	478961.	563567.	1100000.
SM	6038706.	531406.	9868089.	27941234.	44507868.	161700000.
AV	8117.	714.	13264.	37555.	59822.	217339.
MONTHLY SUMMARY (JUN)						
MN	5470.	481.	8939.	0.	0.	0.
MX	15024.	1322.	24551.	781784.	648154.	1100000.
SM	4083106.	359313.	6672364.	68690704.	96970312.	324500000.
AV	5671.	499.	9267.	95404.	134681.	450694.
MONTHLY SUMMARY (JUL)						
MN	5470.	481.	8939.	0.	0.	0.
MX	7372.	649.	12047.	756832.	652015.	1100000.
SM	4199194.	369529.	6862068.	96989632.	130195512.	415800000.
AV	5644.	497.	9223.	130362.	174994.	558871.

	HW-BOILE R LOAD BTU/HR	HW-BOILE R ELECTRIC USE BTU/HR	HW-BOILE R FUEL USE BTU/HR	HERM-REC -CHLR LOAD BTU/HR	HERM-REC -CHLR ELECTRIC USE BTU/HR	HERM-REC -CHLR NOM CAP RUNNING BTU/HR
	---- (1)	---- (3)	---- (4)	---- (1)	---- (3)	---- (7)
MONTHLY SUMMARY (AUG)						
MN	5470.	481.	8939.	0.	0.	0.
MX	7246.	638.	11840.	790832.	662422.	1100000.
SM	4174257.	367335.	6821317.	75888056.	102622968.	353100000.
AV	5611.	494.	9168.	102000.	137934.	474597.
MONTHLY SUMMARY (SEP)						
MN	5470.	481.	8939.	0.	0.	0.
MX	23115.	2034.	37773.	694302.	636314.	1100000.
SM	4292493.	377739.	7014533.	55545692.	76114248.	247500000.
AV	5962.	525.	9742.	77147.	105714.	343750.
MONTHLY SUMMARY (OCT)						
MN	5470.	481.	8939.	0.	0.	0.
MX	395012.	34761.	645504.	353344.	527095.	1100000.
SM	12514075.	1101239.	20449748.	11476159.	20669658.	130900000.
AV	16820.	1480.	27486.	15425.	27782.	175941.
MONTHLY SUMMARY (NOV)						
MN	5470.	481.	8939.	0.	0.	0.
MX	551157.	39600.	855818.	29736.	53669.	1100000.
SM	41524492.	3631633.	67743744.	4169916.	7527555.	277200000.
AV	57673.	5044.	94089.	5792.	10455.	385000.
MONTHLY SUMMARY (DEC)						
MN	5470.	481.	8939.	0.	0.	0.
MX	720212.	39600.	1054609.	36798.	66409.	1100000.
SM	97229072.	8413459.	158159504.	5345248.	9649211.	353100000.
AV	130684.	11308.	212580.	7184.	12969.	474597.
YEARLY SUMMARY						
MN	5470.	481.	8939.	0.	0.	0.
MX	826509.	39600.	1177989.	790832.	662422.	1100000.
SM	459110080.	39545932.	745898112.	363605376.	519959520.	3436399872.
AV	52410.	4514.	85148.	41507.	59356.	392283.

BUILDING 6600
W/SETBACK & VENT
FILE: FIM6600N

MDDHH	AHU-1	AHU-1	AHU-1	AHU-1	AHU-1	AHU-2	AHU-2	AHU-2
	TOT HTG COIL PWR BTU/HR	TOT CLG COIL PWR BTU/HR	SUPPLY ELECTRIC KW	COOLING CAPACITY BTU/HR	HEATING CAPACITY BTU/HR	TOT HTG COIL PWR BTU/HR	TOT CLG COIL PWR BTU/HR	SUPPLY ELECTRIC KW
	---- (5)	---- (6)	----(49)	----(70)	----(78)	----(5)	----(6)	----(49)
MONTHLY SUMMARY (JAN)								
MN	-72897.	0.	0.000	0.	-117423.	-73554.	0.	0.000
MX	0.	0.	1.622	89371.	0.	0.	0.	1.630
SM	-5094304.	0.	441.293	14763275.	-31939120.	-5182080.	0.	443.414
AV	-6847.	0.	0.593	19843.	-42929.	-6965.	0.	0.596
MONTHLY SUMMARY (FEB)								
MN	-98072.	0.	0.000	0.	-117423.	-98907.	0.	0.000
MX	0.	0.	1.622	53856.	0.	0.	0.	1.630
SM	-5295084.	0.	405.600	13463982.	-29355810.	-5378048.	0.	407.550
AV	-7880.	0.	0.604	20036.	-43684.	-8003.	0.	0.606
MONTHLY SUMMARY (MAR)								
MN	-63690.	0.	0.000	0.	-117423.	-64251.	0.	0.000
MX	0.	0.	1.622	88293.	0.	0.	0.	1.630
SM	-2718090.	0.	329.347	11135120.	-23836920.	-2766086.	0.	334.191
AV	-3653.	0.	0.443	14967.	-32039.	-3718.	0.	0.449
MONTHLY SUMMARY (APR)								
MN	-50665.	0.	0.000	0.	-117423.	-51202.	0.	0.000
MX	0.	0.	1.622	207319.	0.	0.	0.	1.630
SM	-897635.	0.	295.277	11662576.	-21371030.	-916560.	0.	296.696
AV	-1247.	0.	0.410	16198.	-29682.	-1273.	0.	0.412
MONTHLY SUMMARY (MAY)								
MN	0.	0.	0.000	0.	0.	0.	0.	0.000
MX	0.	71081.	1.622	149530.	0.	0.	71117.	1.630
SM	0.	5085289.	399.110	17095286.	0.	0.	5072982.	402.659
AV	0.	6835.	0.536	22978.	0.	0.	6819.	0.541
MONTHLY SUMMARY (JUN)								
MN	0.	0.	0.000	0.	0.	0.	0.	0.000
MX	0.	105633.	1.622	139160.	0.	0.	106036.	1.630
SM	0.	9538664.	350.438	18794680.	0.	0.	9562802.	352.123
AV	0.	13248.	0.487	26104.	0.	0.	13282.	0.489
MONTHLY SUMMARY (JUL)								
MN	0.	0.	0.000	0.	0.	0.	0.	0.000
MX	0.	104614.	1.622	155085.	0.	0.	104998.	1.630
SM	0.	12541720.	410.467	23211612.	0.	0.	12564007.	412.441
AV	0.	16857.	0.552	31198.	0.	0.	16887.	0.554

	AHU-1	AHU-1	AHU-1	AHU-1	AHU-1	AHU-2	AHU-2	AHU-2
	TOT HTG COIL PWR BTU/HR	TOT CLG COIL PWR BTU/HR	SUPPLY ELECTRIC KW	COOLING CAPACITY BTU/HR	HEATING CAPACITY BTU/HR	TOT HTG COIL PWR BTU/HR	TOT CLG COIL PWR BTU/HR	SUPPLY ELECTRIC KW
	---- (5)	---- (6)	---- (49)	---- (70)	---- (78)	---- (5)	---- (6)	---- (49)
MONTHLY SUMMARY (AUG)								
MN	0.	0.	0.000	0.	0.	0.	0.	0.000
MX	0.	106919.	1.622	154787.	0.	0.	107365.	1.630
SM	0.	10273563.	361.795	20393784.	0.	0.	10287344.	363.535
AV	0.	13809.	0.486	27411.	0.	0.	13827.	0.489
MONTHLY SUMMARY (SEP)								
MN	0.	0.	0.000	0.	0.	0.	0.	0.000
MX	0.	93237.	1.622	171754.	0.	0.	93453.	1.630
SM	0.	8367622.	335.837	16703431.	0.	0.	8374004.	339.082
AV	0.	11622.	0.466	23199.	0.	0.	11631.	0.471
MONTHLY SUMMARY (OCT)								
MN	-29201.	0.	0.000	0.	-117423.	-29723.	0.	0.000
MX	0.	61556.	1.622	165857.	0.	0.	61533.	1.630
SM	-182422.	2717909.	356.928	13989230.	-9159013.	-186894.	2699645.	361.904
AV	-245.	3653.	0.480	18803.	-12311.	-251.	3629.	0.486
MONTHLY SUMMARY (NOV)								
MN	-63168.	0.	0.000	0.	-117423.	-63765.	0.	0.000
MX	0.	0.	1.622	117480.	0.	0.	0.	1.630
SM	-1257509.	0.	270.941	9865797.	-19609682.	-1287733.	0.	272.243
AV	-1747.	0.	0.376	13702.	-27236.	-1789.	0.	0.378
MONTHLY SUMMARY (DEC)								
MN	-82563.	0.	0.000	0.	-117423.	-83289.	0.	0.000
MX	0.	0.	1.622	121237.	0.	0.	0.	1.630
SM	-4783987.	0.	438.048	14686347.	-31704274.	-4867402.	0.	443.414
AV	-6430.	0.	0.589	19740.	-42613.	-6542.	0.	0.596
YEARLY SUMMARY								
MN	-98072.	0.	0.000	0.	-117423.	-98907.	0.	0.000
MX	0.	106919.	1.622	207319.	0.	0.	107365.	1.630
SM	-20229030.	48524764.	4395.082	185765120.	-166975856.	-20584802.	48560784.	4429.253
AV	-2309.	5539.	0.502	21206.	-19061.	-2350.	5543.	0.506

MDDHH	AHU-2	AHU-2	AHU-3	AHU-3	AHU-3	AHU-3	AHU-3	AHU-4
	COOLING CAPACITY BTU/HR	HEATING CAPACITY BTU/HR	TOT HTG COIL PWR BTU/HR	TOT CLG COIL PWR BTU/HR	SUPPLY ELECTRIC KW	COOLING CAPACITY BTU/HR	HEATING CAPACITY BTU/HR	TOT HTG COIL PWR BTU/HR
	----(70)	----(78)	----(5)	----(6)	----(49)	----(70)	----(78)	----(5)
MONTHLY SUMMARY (JAN)								
MN	0.	-117988.	-63148.	0.	0.000	0.	-78470.	-38373.
MK	89063.	0.	0.	0.	1.084	539185.	0.	0.
SM	14826378.	-32092664.	-8338688.	0.	429.343	16328718.	-31074254.	-4054137.
AV	19928.	-43135.	-11208.	0.	0.577	21947.	-41766.	-5449.
MONTHLY SUMMARY (FEB)								
MN	0.	-117988.	-73747.	0.	0.000	0.	-78470.	-47249.
MK	54097.	0.	0.	0.	1.084	362283.	0.	0.
SM	13524269.	-29496934.	-7349308.	0.	383.807	13505136.	-27778494.	-3683133.
AV	20125.	-43894.	-10936.	0.	0.571	20097.	-41337.	-5481.
MONTHLY SUMMARY (MAR)								
MN	0.	-117988.	-50687.	0.	0.000	0.	-78470.	-31151.
MK	88259.	0.	0.	0.	1.084	243302.	0.	0.
SM	11288214.	-24187486.	-4418406.	0.	365.375	12651378.	-26444500.	-2089899.
AV	15172.	-32510.	-5939.	0.	0.491	17005.	-35544.	-2809.
MONTHLY SUMMARY (APR)								
MN	0.	-117988.	-44623.	0.	0.000	0.	-78470.	-27133.
MK	207183.	0.	0.	0.	1.084	750497.	0.	0.
SM	11686218.	-21473768.	-1791097.	0.	267.797	10872234.	-19382168.	-781052.
AV	16231.	-29825.	-2488.	0.	0.372	15100.	-26920.	-1085.
MONTHLY SUMMARY (MAY)								
MN	0.	0.	0.	0.	0.000	0.	0.	0.
MK	150787.	0.	0.	43142.	1.084	471190.	0.	0.
SM	17224540.	0.	0.	2255740.	488.974	21451554.	0.	0.
AV	23151.	0.	0.	3032.	0.657	28833.	0.	0.
MONTHLY SUMMARY (JUN)								
MN	0.	0.	0.	0.	0.000	0.	0.	0.
MK	140060.	0.	0.	69821.	1.084	113310.	0.	0.
SM	18887194.	0.	0.	5169905.	273.218	14986514.	0.	0.
AV	26232.	0.	0.	7180.	0.379	20815.	0.	0.
MONTHLY SUMMARY (JUL)								
MN	0.	0.	0.	0.	0.000	0.	0.	0.
MK	156396.	0.	0.	68387.	1.084	132557.	0.	0.
SM	23318834.	0.	0.	7582648.	261.292	15180491.	0.	0.
AV	31343.	0.	0.	10192.	0.351	20404.	0.	0.

	AHU-2	AHU-2	AHU-3	AHU-3	AHU-3	AHU-3	AHU-3	AHU-4
	COOLING CAPACITY BTU/HR	HEATING CAPACITY BTU/HR	TOT HTG COIL PWR BTU/HR	TOT CLG COIL PWR BTU/HR	SUPPLY ELECTRIC KW	COOLING CAPACITY BTU/HR	HEATING CAPACITY BTU/HR	TOT HTG COIL PWR BTU/HR
	---- (70)	---- (78)	---- (5)	---- (6)	---- (49)	---- (70)	---- (78)	---- (5)
MONTHLY SUMMARY (AUG)								
MN	0.	0.	0.	0.	0.000	0.	0.	0.
MX	156134.	0.	0.	70975.	1.084	188538.	0.	0.
SM	20489192.	0.	0.	5803217.	212.503	12368698.	0.	0.
AV	27539.	0.	0.	7800.	0.286	16625.	0.	0.
MONTHLY SUMMARY (SEP)								
MN	0.	0.	0.	0.	0.000	0.	0.	0.
MX	173981.	0.	0.	65935.	1.084	162771.	0.	0.
SM	16840638.	0.	0.	4795327.	310.081	14912618.	0.	0.
AV	23390.	0.	0.	6660.	0.431	20712.	0.	0.
MONTHLY SUMMARY (OCT)								
MN	0.	-117988.	-31131.	0.	0.000	0.	-78470.	-20781.
MX	168444.	0.	0.	33792.	1.084	653629.	0.	0.
SM	14171077.	-9203044.	-445608.	930672.	344.776	14441250.	-6905388.	-215673.
AV	19047.	-12370.	-599.	1251.	0.463	19410.	-9281.	-290.
MONTHLY SUMMARY (NOV)								
MN	0.	-117988.	-46537.	0.	0.000	0.	-78470.	-30181.
MX	117559.	0.	0.	0.	1.084	85013.	0.	0.
SM	9897429.	-19703954.	-2883318.	0.	308.997	10977976.	-22364042.	-1300325.
AV	13746.	-27367.	-4005.	0.	0.429	15247.	-31061.	-1806.
MONTHLY SUMMARY (DEC)								
MN	0.	-117988.	-65606.	0.	0.000	0.	-78470.	-41192.
MX	120882.	0.	0.	0.	1.084	1022489.	0.	0.
SM	14857916.	-32092662.	-7578693.	0.	438.017	16984426.	-31702012.	-3693379.
AV	19970.	-43135.	-10186.	0.	0.589	22829.	-42610.	-4964.
YEARLY SUMMARY								
MN	0.	-117988.	-73747.	0.	0.000	0.	-78470.	-47249.
MX	207183.	0.	0.	70975.	1.084	1022489.	0.	0.
SM	187011888.	-168250512.	-32805116.	26537506.	4084.182	174660976.	-165650848.	-15817597.
AV	21348.	-19207.	-3745.	3029.	0.466	19938.	-18910.	-1806.

MMDDHH	AHU-4	AHU-4	AHU-4	AHU-4	AHU-5	AHU-5	AHU-5	AHU-5
	TOT CLG COIL PWR BTU/HR	SUPPLY ELECTRIC KW	COOLING CAPACITY BTU/HR	HEATING CAPACITY BTU/HR	TOT HTG COIL PWR BTU/HR	TOT CLG COIL PWR BTU/HR	SUPPLY ELECTRIC KW	COOLING CAPACITY BTU/HR
	---- (6)	---- (49)	---- (70)	---- (78)	---- (5)	---- (6)	---- (49)	---- (70)
MONTHLY SUMMARY (JAN)								
MN	0.	0.000	0.	-53066.	-102228.	0.	0.000	0.
MX	0.	0.733	192720.	0.	0.	0.	1.521	645115.
SM	0.	255.887	8949529.	-18520124.	-15197826.	0.	585.585	20223338.
AV	0.	0.344	12029.	-24893.	-20427.	0.	0.787	27182.
MONTHLY SUMMARY (FEB)								
MN	0.	0.000	0.	-53066.	-112755.	0.	0.000	0.
MX	0.	0.733	359620.	0.	0.	0.	1.521	262648.
SM	0.	231.691	8264503.	-16768935.	-13260495.	0.	529.308	17920896.
AV	0.	0.345	12298.	-24954.	-19733.	0.	0.788	26668.
MONTHLY SUMMARY (MAR)								
MN	0.	0.000	0.	-53066.	-85259.	0.	0.000	0.
MX	0.	0.733	64781.	0.	0.	0.	1.521	138436.
SM	0.	214.094	7339817.	-15495346.	-8590913.	0.	498.888	16487695.
AV	0.	0.288	9865.	-20827.	-11547.	0.	0.671	22161.
MONTHLY SUMMARY (APR)								
MN	0.	0.000	0.	-53066.	-73500.	0.	0.000	0.
MX	0.	0.733	103735.	0.	0.	0.	1.521	146593.
SM	0.	145.174	5683472.	-10507119.	-3669650.	0.	358.956	12516142.
AV	0.	0.202	7894.	-14593.	-5097.	0.	0.499	17384.
MONTHLY SUMMARY (MAY)								
MN	0.	0.000	0.	0.	0.	0.	0.000	0.
MX	30220.	0.733	259465.	0.	0.	53107.	1.521	474528.
SM	1852733.	253.687	10876316.	0.	0.	2357355.	722.475	29666488.
AV	2490.	0.341	14619.	0.	0.	3168.	0.971	39874.
MONTHLY SUMMARY (JUN)								
MN	0.	0.000	0.	0.	0.	0.	0.000	0.
MX	48229.	0.733	71916.	0.	0.	94321.	1.521	117023.
SM	3890460.	164.970	9072740.	0.	0.	6398328.	354.393	17886896.
AV	5403.	0.229	12601.	0.	0.	8887.	0.492	24843.
MONTHLY SUMMARY (JUL)								
MN	0.	0.000	0.	0.	0.	0.	0.000	0.
MX	46418.	0.733	82221.	0.	0.	89697.	1.521	141437.
SM	5468611.	182.567	10535168.	0.	0.	9776542.	331.578	17890850.
AV	7350.	0.245	14160.	0.	0.	13141.	0.446	24047.

	AHU-4	AHU-4	AHU-4	AHU-4	AHU-5	AHU-5	AHU-5	AHU-5
	TOT CLG COIL PWR BTU/HR	SUPPLY ELECTRIC KW	COOLING CAPACITY BTU/HR	HEATING CAPACITY BTU/HR	TOT HTG COIL PWR BTU/HR	TOT CLG COIL PWR BTU/HR	SUPPLY ELECTRIC KW	COOLING CAPACITY BTU/HR
	---- (6)	----(49)	---- (70)	---- (78)	---- (5)	---- (6)	---- (49)	---- (70)
MONTHLY SUMMARY (AUG)								
MN	0.	0.000	0.	0.	0.	0.	0.000	0.
MX	48883.	0.733	79264.	0.	0.	95534.	1.521	189626.
SM	4259171.	147.373	8484180.	0.	0.	7195521.	276.822	14718397.
AV	5725.	0.198	11403.	0.	0.	9671.	0.372	19783.
MONTHLY SUMMARY (SEP)								
MN	0.	0.000	0.	0.	0.	0.	0.000	0.
MX	43896.	0.733	108379.	0.	0.	84224.	1.521	179455.
SM	3438667.	173.768	8516545.	0.	0.	5594154.	485.199	21129874.
AV	4776.	0.241	11829.	0.	0.	7770.	0.674	29347.
MONTHLY SUMMARY (OCT)								
MN	0.	0.000	0.	-53066.	-58473.	0.	0.000	0.
MX	24479.	0.733	76679.	0.	0.	33794.	1.521	559460.
SM	820971.	201.630	7996448.	-4245301.	-1184530.	584548.	561.249	21806460.
AV	1103.	0.271	10748.	-5706.	-1592.	786.	0.754	29310.
MONTHLY SUMMARY (NOV)								
MN	0.	0.000	0.	-53066.	-81028.	0.	0.000	0.
MX	0.	0.733	56293.	0.	0.	0.	1.521	93380.
SM	0.	175.235	6276673.	-12682836.	-5942147.	0.	430.443	14494094.
AV	0.	0.243	8718.	-17615.	-8253.	0.	0.598	20131.
MONTHLY SUMMARY (DEC)								
MN	0.	0.000	0.	-53066.	-105034.	0.	0.000	0.
MX	0.	0.733	348879.	0.	0.	0.	1.521	863783.
SM	0.	259.553	9167927.	-18785454.	-13979142.	0.	594.711	20468328.
AV	0.	0.349	12322.	-25249.	-18789.	0.	0.799	27511.
YEARLY SUMMARY								
MN	0.	0.000	0.	-53066.	-112755.	0.	0.000	0.
MX	48883.	0.733	359620.	0.	0.	95534.	1.521	863783.
SM	19730612.	2405.629	101163320.	-97005120.	-61824704.	31906446.	5729.607	225209472.
AV	2252.	0.275	11548.	-11074.	-7058.	3642.	0.654	25709.

MMDDHH	AHU-5	AHU-6	AHU-6	AHU-6	AHU-6	AHU-6	AHU-7	AHU-7
	HEATING CAPACITY BTU/HR	TOT HTG COIL PWR BTU/HR	TOT CLG COIL PWR BTU/HR	SUPPLY ELECTRIC KW	COOLING CAPACITY BTU/HR	HEATING CAPACITY BTU/HR	TOT HTG COIL PWR BTU/HR	TOT CLG COIL PWR BTU/HR
	----(78)	----(5)	----(6)	----(49)	----(70)	----(78)	----(5)	----(6)
MONTHLY SUMMARY (JAN)								
MN	-110084.	-53348.	0.	0.000	0.	-62099.	-41616.	0.
MX	0.	0.	0.	0.858	551749.	0.	0.	0.
SM	-42382444.	-6761053.	0.	311.454	11092458.	-22541872.	-2405476.	0.
AV	-56966.	-9087.	0.	0.419	14909.	-30298.	-3233.	0.
MONTHLY SUMMARY (FEB)								
MN	-110084.	-62969.	0.	0.000	0.	-62099.	-56760.	0.
MX	0.	0.	0.	0.858	417106.	0.	0.	0.
SM	-38309328.	-5974946.	0.	283.998	9831488.	-20554710.	-2577486.	0.
AV	-57008.	-8891.	0.	0.423	14630.	-30587.	-3836.	0.
MONTHLY SUMMARY (MAR)								
MN	-110084.	-42498.	0.	0.000	0.	-62099.	-36043.	0.
MX	0.	0.	0.	0.858	79205.	0.	0.	0.
SM	-36107640.	-3771399.	0.	265.980	8941889.	-19250634.	-1208627.	0.
AV	-48532.	-5069.	0.	0.358	12019.	-25875.	-1624.	0.
MONTHLY SUMMARY (APR)								
MN	-110084.	-36718.	0.	0.000	0.	-62099.	-28382.	0.
MX	0.	0.	0.	0.858	100297.	0.	0.	0.
SM	-25979888.	-1557597.	0.	189.618	6937423.	-13723841.	-387567.	0.
AV	-36083.	-2163.	0.	0.263	9635.	-19061.	-538.	0.
MONTHLY SUMMARY (MAY)								
MN	0.	0.	0.	0.000	0.	0.	0.	0.
MX	0.	0.	32255.	0.858	312266.	0.	0.	49017.
SM	0.	0.	1618989.	369.798	15235612.	0.	0.	3929315.
AV	0.	0.	2176.	0.497	20478.	0.	0.	5281.
MONTHLY SUMMARY (JUN)								
MN	0.	0.	0.	0.000	0.	0.	0.	0.
MX	0.	0.	54695.	0.858	83263.	0.	0.	69885.
SM	0.	0.	3898283.	191.334	9986657.	0.	0.	6609332.
AV	0.	0.	5414.	0.266	13870.	0.	0.	9180.
MONTHLY SUMMARY (JUL)								
MN	0.	0.	0.	0.000	0.	0.	0.	0.
MX	0.	0.	52199.	0.858	82896.	0.	0.	69280.
SM	0.	0.	5700405.	189.618	10448418.	0.	0.	8523816.
AV	0.	0.	7662.	0.255	14044.	0.	0.	11457.

	AHU-5	AHU-6	AHU-6	AHU-6	AHU-6	AHU-6	AHU-7	AHU-7
	HEATING CAPACITY BTU/HR	TOT HTG COIL PWR BTU/HR	TOT CLG COIL PWR BTU/HR	SUPPLY ELECTRIC KW	COOLING CAPACITY BTU/HR	HEATING CAPACITY BTU/HR	TOT HTG COIL PWR BTU/HR	TOT CLG COIL PWR BTU/HR
	--- (78)	--- (5)	--- (6)	--- (49)	--- (70)	--- (78)	--- (5)	--- (6)
MONTHLY SUMMARY (AUG)								
MN	0.	0.	0.	0.000	0.	0.	0.	0.
MX	0.	0.	55083.	0.858	121131.	0.	0.	70553.
SM	0.	0.	4251554.	151.008	8258081.	0.	0.	7058736.
AV	0.	0.	5714.	0.203	11100.	0.	0.	9488.
MONTHLY SUMMARY (SEP)								
MN	0.	0.	0.	0.000	0.	0.	0.	0.
MX	0.	0.	48229.	0.858	457947.	0.	0.	62705.
SM	0.	0.	3415973.	250.536	11874539.	0.	0.	5978299.
AV	0.	0.	4744.	0.348	16492.	0.	0.	8303.
MONTHLY SUMMARY (OCT)								
MN	-110084.	-30587.	0.	0.000	0.	-62099.	-14559.	0.
MX	0.	0.	22946.	0.858	446234.	0.	0.	43515.
SM	-10347920.	-474347.	507045.	288.288	11813241.	-5402597.	-67825.	2322979.
AV	-13908.	-638.	682.	0.387	15878.	-7262.	-91.	3122.
MONTHLY SUMMARY (NOV)								
MN	-110084.	-41601.	0.	0.000	0.	-62099.	-36065.	0.
MX	0.	0.	0.	0.858	59249.	0.	0.	0.
SM	-31153850.	-2483568.	0.	223.938	7753841.	-16207792.	-525118.	0.
AV	-43269.	-3449.	0.	0.311	10769.	-22511.	-729.	0.
MONTHLY SUMMARY (DEC)								
MN	-110084.	-57412.	0.	0.000	0.	-62099.	-47316.	0.
MX	0.	0.	0.	0.858	66772.	0.	0.	0.
SM	-43042952.	-6194873.	0.	314.028	10535124.	-22728168.	-2164820.	0.
AV	-57853.	-8326.	0.	0.422	14160.	-30549.	-2910.	0.
YEARLY SUMMARY								
MN	-110084.	-62969.	0.	0.000	0.	-62099.	-56760.	0.
MX	0.	0.	55083.	0.858	551749.	0.	0.	70553.
SM	-227324032.	-27217780.	19392250.	3029.598	122708768.	-120409616.	-9336919.	34422476.
AV	-25950.	-3107.	2214.	0.346	14008.	-13745.	-1066.	3930.

MMDDHH	AHU-7	AHU-7	AHU-7	AHU-8	AHU-8	AHU-8	AHU-8	AHU-8
	SUPPLY ELECTRIC KW	COOLING CAPACITY BTU/HR	HEATING CAPACITY BTU/HR	TOT HTG COIL PWR BTU/HR	TOT CLG COIL PWR BTU/HR	SUPPLY ELECTRIC KW	COOLING CAPACITY BTU/HR	HEATING CAPACITY BTU/HR
	----(49)	----(70)	----(78)	----(5)	----(6)	----(49)	----(70)	----(78)
MONTHLY SUMMARY (JAN)								
MN	0.000	0.	-75648.	-193921.	0.	0.000	0.	-235411.
MX	1.045	68587.	0.	0.	0.	3.253	1388056.	0.
SM	262.345	8922539.	-18987560.	-27766826.	0.	1372.597	50728412.	-99343416.
AV	0.353	11993.	-25521.	-37321.	0.	1.845	68183.	-133526.
MONTHLY SUMMARY (FEB)								
MN	0.000	0.	-75648.	-217224.	0.	0.000	0.	-235411.
MX	1.045	38627.	0.	0.	0.	3.253	1067827.	0.
SM	244.577	8212448.	-17701548.	-22736570.	0.	1206.715	41744712.	-87337464.
AV	0.364	12221.	-26342.	-33834.	0.	1.796	62120.	-129966.
MONTHLY SUMMARY (MAR)								
MN	0.000	0.	-75648.	-141879.	0.	0.000	0.	-235411.
MX	1.045	66910.	0.	0.	0.	3.253	208601.	0.
SM	196.498	6858298.	-14221755.	-13154682.	0.	1070.106	34159992.	-77450200.
AV	0.264	9218.	-19115.	-17681.	0.	1.438	45914.	-104100.
MONTHLY SUMMARY (APR)								
MN	0.000	0.	-75648.	-135516.	0.	0.000	0.	-235411.
MX	1.045	431080.	0.	0.	0.	3.253	1281512.	0.
SM	198.588	9687681.	-14373051.	-5269075.	0.	718.825	25188136.	-52025828.
AV	0.276	13455.	-19963.	-7318.	0.	0.998	34984.	-72258.
MONTHLY SUMMARY (MAY)								
MN	0.000	0.	0.	0.	0.	0.000	0.	0.
MX	1.045	112027.	0.	0.	107088.	3.253	1007975.	0.
SM	251.893	11579046.	0.	0.	6212329.	1245.746	48571532.	0.
AV	0.339	15563.	0.	0.	8350.	1.674	65284.	0.
MONTHLY SUMMARY (JUN)								
MN	0.000	0.	0.	0.	0.	0.000	0.	0.
MX	1.045	104934.	0.	0.	183828.	3.253	229575.	0.
SM	241.441	13383738.	0.	0.	16187750.	822.908	41081068.	0.
AV	0.335	18589.	0.	0.	22483.	1.143	57057.	0.
MONTHLY SUMMARY (JUL)								
MN	0.000	0.	0.	0.	0.	0.000	0.	0.
MX	1.045	106678.	0.	0.	179444.	3.253	249575.	0.
SM	287.430	16686442.	0.	0.	22880340.	923.739	47571328.	0.
AV	0.386	22428.	0.	0.	30753.	1.242	63940.	0.

	AHU-7	AHU-7	AHU-7	AHU-8	AHU-8	AHU-8	AHU-8	AHU-8
	SUPPLY ELECTRIC KW	COOLING CAPACITY BTU/HR	HEATING CAPACITY BTU/HR	TOT HTG COIL PWR BTU/HR	TOT CLG COIL PWR BTU/HR	SUPPLY ELECTRIC KW	COOLING CAPACITY BTU/HR	HEATING CAPACITY BTU/HR
	----(49)	----(70)	----(78)	----(5)	----(6)	----(49)	----(70)	----(78)
MONTHLY SUMMARY (AUG)								
MN	0.000	0.	0.	0.	0.	0.000	0.	0.
MX	1.045	110644.	0.	0.	185087.	3.253	292647.	0.
SM	252.938	14673657.	0.	0.	17197336.	816.403	42258252.	0.
AV	0.340	19723.	0.	0.	23115.	1.097	56799.	0.
MONTHLY SUMMARY (SEP)								
MN	0.000	0.	0.	0.	0.	0.000	0.	0.
MX	1.045	124735.	0.	0.	156307.	3.253	271320.	0.
SM	232.034	12188944.	0.	0.	11403332.	975.780	41215560.	0.
AV	0.322	16929.	0.	0.	15838.	1.355	57244.	0.
MONTHLY SUMMARY (OCT)								
MN	0.000	0.	-75648.	-101567.	0.	0.000	0.	-235411.
MX	1.045	135613.	0.	0.	73224.	3.253	1293575.	0.
SM	222.628	9338200.	-6203107.	-1918272.	1694352.	1174.189	42852668.	-22834864.
AV	0.299	12551.	-8338.	-2578.	2277.	1.578	57598.	-30692.
MONTHLY SUMMARY (NOV)								
MN	0.000	0.	-75648.	-132699.	0.	0.000	0.	-235411.
MX	1.045	85607.	0.	0.	0.	3.253	166349.	0.
SM	159.916	6221697.	-11574089.	-10080114.	0.	975.780	31501632.	-70623288.
AV	0.222	8641.	-16075.	-14000.	0.	1.355	43752.	-98088.
MONTHLY SUMMARY (DEC)								
MN	0.000	0.	-75648.	-190043.	0.	0.000	0.	-235411.
MX	1.045	100251.	0.	0.	0.	3.253	3536454.	0.
SM	268.616	9178005.	-19441444.	-25552466.	0.	1398.618	49462800.	-101226712.
AV	0.361	12336.	-26131.	-34345.	0.	1.880	66482.	-136057.
YEARLY SUMMARY								
MN	0.000	0.	-75648.	-217224.	0.	0.000	0.	-235411.
MX	1.045	431080.	0.	0.	185087.	3.253	3536454.	0.
SM	2818.905	126930688.	-102502560.	-106478000.	75575440.	12701.405	496336064.	-510841760.
AV	0.322	14490.	-11701.	-12155.	8627.	1.450	56659.	-58315.

MMDDHH	AHU-9	AHU-9	AHU-9	AHU-9	AHU-9
	TOT HTG COIL PWR BTU/HR	TOT CLG COIL PWR BTU/HR	SUPPLY ELECTRIC KW	COOLING CAPACITY BTU/HR	HEATING CAPACITY BTU/HR
	---- (5)	---- (6)	---- (49)	---- (70)	---- (78)
MONTHLY SUMMARY (JAN)					
MN	-33760.	0.	0.000	0.	-45727.
MX	0.	0.	0.632	19159.	0.
SM	-2419739.	0.	154.791	4693955.	-11203190.
AV	-3252.	0.	0.208	6309.	-15058.
MONTHLY SUMMARY (FEB)					
MN	-43450.	0.	0.000	0.	-45727.
MX	0.	0.	0.632	19159.	0.
SM	-2415450.	0.	140.260	4253298.	-10151463.
AV	-3594.	0.	0.209	6329.	-15106.
MONTHLY SUMMARY (MAR)					
MN	-27880.	0.	0.000	0.	-45727.
MX	0.	0.	0.632	20869.	0.
SM	-1234616.	0.	114.356	3476245.	-8276643.
AV	-1659.	0.	0.154	4672.	-11125.
MONTHLY SUMMARY (APR)					
MN	-19341.	0.	0.000	0.	-45727.
MX	0.	0.	0.632	25703.	0.
SM	-354246.	0.	114.988	3680022.	-8322370.
AV	-492.	0.	0.160	5111.	-11559.
MONTHLY SUMMARY (MAY)					
MN	0.	0.	0.000	0.	0.
MX	0.	22514.	0.632	31973.	0.
SM	0.	1673604.	128.887	4674751.	0.
AV	0.	2249.	0.173	6283.	0.
MONTHLY SUMMARY (JUN)					
MN	0.	0.	0.000	0.	0.
MX	0.	34372.	0.632	36198.	0.
SM	0.	3557101.	133.942	5989896.	0.
AV	0.	4940.	0.186	8319.	0.
MONTHLY SUMMARY (JUL)					
MN	0.	0.	0.000	0.	0.
MX	0.	33653.	0.632	36966.	0.
SM	0.	4652781.	160.477	7573242.	0.
AV	0.	6254.	0.216	10179.	0.

	AHU-9	AHU-9	AHU-9	AHU-9	AHU-9
	TOT HTG COIL PWR BTU/HR	TOT CLG COIL PWR BTU/HR	SUPPLY ELECTRIC KW	COOLING CAPACITY BTU/HR	HEATING CAPACITY BTU/HR
	---- (5)	---- (6)	----(49)	----(70)	----(78)
MONTHLY SUMMARY (AUG)					
MN	0.	0.	0.000	0.	0.
MX	0.	34866.	0.632	35592.	0.
SM	0.	3824039.	138.364	6501416.	0.
AV	0.	5140.	0.186	8738.	0.
MONTHLY SUMMARY (SEP)					
MN	0.	0.	0.000	0.	0.
MX	0.	30497.	0.632	34759.	0.
SM	0.	3034451.	125.096	5144474.	0.
AV	0.	4215.	0.174	7145.	0.
MONTHLY SUMMARY (OCT)					
MN	-10095.	0.	0.000	0.	-45727.
MX	0.	18200.	0.632	26279.	0.
SM	-57344.	778926.	128.255	4234155.	-3566730.
AV	-77.	1047.	0.172	5691.	-4794.
MONTHLY SUMMARY (NOV)					
MN	-28826.	0.	0.000	0.	-45727.
MX	0.	0.	0.632	29132.	0.
SM	-583657.	0.	90.347	2822989.	-6539005.
AV	-811.	0.	0.125	3921.	-9082.
MONTHLY SUMMARY (DEC)					
MN	-37907.	0.	0.000	0.	-45727.
MX	0.	0.	0.632	19159.	0.
SM	-2329358.	0.	157.950	4789750.	-11431827.
AV	-3131.	0.	0.212	6438.	-15365.
YEARLY SUMMARY					
MN	-43450.	0.	0.000	0.	-45727.
MX	0.	34866.	0.632	36966.	0.
SM	-9394408.	17520902.	1587.714	57834188.	-59491224.
AV	-1072.	2000.	0.181	6602.	-6791.

MMDDHH	FC-1	FC-1	FC-1	FC-1	FC-1
	TOT HTG COIL PWR BTU/HR	TOT CLG COIL PWR BTU/HR	SUPPLY ELECTRIC KW	COOLING CAPACITY BTU/HR	HEATING CAPACITY BTU/HR
	---- (5)	---- (6)	---- (49)	---- (70)	---- (78)
MONTHLY SUMMARY (JAN)					
MN	0.	0.	0.090	27165.	0.
MK	0.	10627.	0.090	40223.	0.
SM	0.	72633.	15.261	5213129.	0.
AV	0.	430.	0.090	30847.	0.
MONTHLY SUMMARY (FEB)					
MN	0.	0.	0.090	27154.	0.
MK	0.	5156.	0.090	42051.	0.
SM	0.	59725.	14.087	4921567.	0.
AV	0.	383.	0.090	31549.	0.
MONTHLY SUMMARY (MAR)					
MN	0.	0.	0.090	27154.	0.
MK	0.	6911.	0.090	32866.	0.
SM	0.	117335.	15.261	4764301.	0.
AV	0.	694.	0.090	28191.	0.
MONTHLY SUMMARY (APR)					
MN	0.	0.	0.090	27154.	0.
MK	0.	4030.	0.090	30632.	0.
SM	0.	117087.	16.435	5130150.	0.
AV	0.	643.	0.090	28188.	0.
MONTHLY SUMMARY (MAY)					
MN	0.	0.	0.090	28449.	0.
MK	0.	0.	0.090	61093.	0.
SM	0.	0.	14.087	6386861.	0.
AV	0.	0.	0.090	40941.	0.
MONTHLY SUMMARY (JUN)					
MN	0.	0.	0.090	31883.	0.
MK	0.	0.	0.090	93779.	0.
SM	0.	0.	15.261	9202484.	0.
AV	0.	0.	0.090	54453.	0.
MONTHLY SUMMARY (JUL)					
MN	0.	0.	0.090	39899.	0.
MK	0.	0.	0.090	96027.	0.
SM	0.	0.	16.435	11666405.	0.
AV	0.	0.	0.090	64101.	0.

	FC-1	FC-1	FC-1	FC-1	FC-1
	TOT HTG COIL PWR BTU/HR	TOT CLG COIL PWR BTU/HR	SUPPLY ELECTRIC KW	COOLING CAPACITY BTU/HR	HEATING CAPACITY BTU/HR
	---- (5)	---- (6)	----(49)	---- (70)	---- (78)
MONTHLY SUMMARY (AUG)					
MN	0.	0.	0.090	33651.	0.
MX	0.	0.	0.090	87587.	0.
SM	0.	0.	14.087	9804835.	0.
AV	0.	0.	0.090	62852.	0.
MONTHLY SUMMARY (SEP)					
MN	0.	0.	0.090	28795.	0.
MX	0.	0.	0.090	88494.	0.
SM	0.	0.	16.435	9325010.	0.
AV	0.	0.	0.090	51236.	0.
MONTHLY SUMMARY (OCT)					
MN	0.	0.	0.090	27317.	0.
MX	0.	2030.	0.090	49036.	0.
SM	0.	2030.	15.261	5478183.	0.
AV	0.	12.	0.090	32415.	0.
MONTHLY SUMMARY (NOV)					
MN	0.	0.	0.090	27154.	0.
MX	0.	5605.	0.090	41313.	0.
SM	0.	82676.	11.739	3664462.	0.
AV	0.	636.	0.090	28188.	0.
MONTHLY SUMMARY (DEC)					
MN	0.	0.	0.090	27414.	0.
MX	0.	1615.	0.090	36552.	0.
SM	0.	39493.	17.609	5787231.	0.
AV	0.	203.	0.090	29678.	0.
YEARLY SUMMARY					
MN	0.	0.	0.090	27154.	0.
MX	0.	10627.	0.090	96027.	0.
SM	0.	490979.	181.955	81344624.	0.
AV	0.	244.	0.090	40370.	0.

S I T E E N E R G Y													
MONTH	2	3	4	5	6	7	8	9	10	11	12	13	14
TOTAL HEAT LOAD	TOTAL COOLING LOAD	TOTAL ELECTR LOAD	RCVRED ENERGY	WASTED RCVRABL ENERGY	FUEL INPUT COOLING	ELEC INPUT COOLING	FUEL INPUT HEATING	ELEC INPUT HEATING	FUEL INPUT ELECT	TOTAL FUEL INPUT	TOTAL SITE ENERGY	TOTAL SOURCE ENERGY	
JAN	81.2	4.7	55.4 16.2E	0.0	0.0	0.0	11.0 3.2E	132.1	9.3 2.7E	0.0	132.1	187.5	298.4
FEB	72.3	5.0	51.3 15.0E	0.0	0.0	0.0	11.7 3.4E	116.7	8.1 2.4E	0.0	116.7	168.0	270.8
MAR	44.0	4.6	48.3 14.1E	0.0	0.0	0.0	10.6 3.1E	71.7	6.1 1.8E	0.0	71.7	120.0	216.7
APR	19.5	2.5	38.7 11.3E	0.0	0.0	0.0	5.8 1.7E	31.9	3.9 1.1E	0.0	31.9	70.6	148.2
MAY	5.1	32.8	91.5 26.8E	0.0	0.0	0.0	54.4 15.9E	8.4	2.7 0.8E	0.0	8.4	99.9	283.1
JUN	4.0	69.4	132.5 38.8E	0.0	0.0	0.0	100.5 29.4E	6.5	2.5 0.7E	0.0	6.5	139.0	404.4
JUL	4.1	95.6	165.8 48.6E	0.0	0.0	0.0	131.2 38.4E	6.8	2.6 0.8E	0.0	6.8	172.5	504.6
AUG	4.1	75.2	135.4 39.7E	0.0	0.0	0.0	104.2 30.5E	6.7	2.6 0.8E	0.0	6.7	142.1	413.3
SEP	4.1	58.1	116.3 34.1E	0.0	0.0	0.0	82.6 24.2E	6.7	2.5 0.7E	0.0	6.7	123.0	356.0
OCT	10.3	15.2	64.0 18.7E	0.0	0.0	0.0	27.9 8.2E	16.9	3.1 0.9E	0.0	16.9	80.9	209.0
NOV	30.2	3.4	40.5 11.9E	0.0	0.0	0.0	7.9 2.3E	49.4	4.8 1.4E	0.0	49.4	89.8	170.9
DEC	75.2	5.2	56.9 16.7E	0.0	0.0	0.0	12.1 3.6E	122.4	8.8 2.6E	0.0	122.4	179.3	293.2
=====	354.3	371.6	996.5 291.8E	0.0	0.0	0.0	559.8 163.9E	576.1	57.0 16.7E	0.0	576.1	1572.6	3568.5

NOTE-- ALL ENTRIES ARE IN MBTU EXCEPT
 ENTRIES FOLLOWED BY E ARE IN MWH (THOUSANDS OF KWH)

ENTECH ENGINEERING
 READING, PA 19603
 REPORT- PS-B MONTHLY PEAK AND TOTAL ENERGY USE

EZDOE - ELITE SOFTWARE DEVELOPMENT INC
 FT. GEORGE G. MEADE

DOE-2.1D 6/28/1996 10:32:48 PDL RUN 1
 EMCS STUDY WEATHER FILE- BALTIMORE, MD

MO	UTILITY-	ELECTRICITY	NATURAL-GAS
	TOTAL (MBTU)	55.384	132.074
JAN	PEAK (KBTU)	197.435	993.283
	DY/HR	20/11	15/ 9
	TOTAL (MBTU)	51.335	116.665
FEB	PEAK (KBTU)	197.625	1166.466
	DY/HR	4/11	3/ 9
	TOTAL (MBTU)	48.268	71.710
MAR	PEAK (KBTU)	191.059	839.391
	DY/HR	4/11	4/ 9
	TOTAL (MBTU)	38.745	31.880
APR	PEAK (KBTU)	186.688	760.597
	DY/HR	8/11	8/ 9
	TOTAL (MBTU)	91.486	8.383
MAY	PEAK (KBTU)	692.767	47.387
	DY/HR	21/17	10/ 7
	TOTAL (MBTU)	132.496	6.547
JUN	PEAK (KBTU)	777.160	20.181
	DY/HR	10/18	3/ 9
	TOTAL (MBTU)	165.784	6.762
JUL	PEAK (KBTU)	780.988	10.820
	DY/HR	9/17	2/ 9
	TOTAL (MBTU)	135.392	6.714
AUG	PEAK (KBTU)	791.427	10.746
	DY/HR	18/17	5/ 9
	TOTAL (MBTU)	116.314	6.690
SEP	PEAK (KBTU)	765.327	26.994
	DY/HR	1/17	30/ 9
	TOTAL (MBTU)	63.957	16.910
OCT	PEAK (KBTU)	664.602	575.407
	DY/HR	13/17	27/ 9
	TOTAL (MBTU)	40.461	49.355
NOV	PEAK (KBTU)	187.451	829.855
	DY/HR	25/11	25/ 9
	TOTAL (MBTU)	56.866	122.389
DEC	PEAK (KBTU)	197.266	1049.422
	DY/HR	22/11	22/ 9
	ONE YEAR	996.488	576.080
	USE/PEAK	791.427	1166.466

ENTECH ENGINEERING
READING, PA 19603
REPORT- PS-D PLANT LOADS SATISFIED

EZDOE - ELITE SOFTWARE DEVELOPMENT INC
FT. GEORGE G. MEADE

DOE-2.1D 6/28/1996 10:32:48 PDL RUN 1
EMCS STUDY WEATHER FILE- BALTIMORE, MD

HEATING LOADS	MBTU SUPPLIED	PCT OF TOTAL LOAD
-----	-----	-----
HW-BOILER	354.3	100.0
	=====	=====
LOAD SATISFIED	354.3	100.0
TOTAL LOAD ON PLANT	354.3	

COOLING LOADS	MBTU SUPPLIED	PCT OF TOTAL LOAD
-----	-----	-----
HERM-REC-CHLR	371.6	100.0
	=====	=====
LOAD SATISFIED	371.6	100.0
TOTAL LOAD ON PLANT	371.6	

ELECTRICAL LOADS	MBTU SUPPLIED	PCT OF TOTAL LOAD
-----	-----	-----
ELECTRICITY	996.5	100.0
	=====	=====
LOAD SATISFIED	996.5	100.0
TOTAL LOAD ON PLANT	996.5	

ENTECH ENGINEERING
READING, PA 19603
REPORT- PS-D PLANT LOADS SATISFIED

BZDOE - ELITE SOFTWARE DEVELOPMENT INC
FT. GEORGE G. MEADE

DOE-2.1D 6/28/1996 10:32:48 PDL RUN 1
EMCS STUDY

WEATHER FILE- BALTIMORE, MD

----- (CONTINUED) -----

SUMMARY OF LOADS MET

TYPE OF LOAD	TOTAL LOAD (MBTU)	LOAD SATISFIED (MBTU)	TOTAL OVERLOAD (MBTU)	PEAK OVERLOAD (MBTU)	HOURS OVERLOADED
HEATING LOADS	354.3	354.3	0.000	0.000	0
COOLING LOADS	371.6	371.6	0.000	0.000	0
ELECTRICAL LOADS	996.5	996.5	0.000	0.000	0

ENTECH ENGINEERING
READING, PA 19603
REPORT- PS-H EQUIPMENT USE STATISTICS

EZDOE - ELITE SOFTWARE DEVELOPMENT INC
FT. GEORGE G. MEADE

DOE-2.1D 6/28/1996 10:32:48 PDL RUN 1
EMCS STUDY WEATHER FILE- BALTIMORE, MD

E Q U I P M E N T	AVG	MAX	MON	-----		-----		-----		-----	
	OPER RATIO	LOAD (MBTU)	DAY HR	SIZE (MBTU)	OPER HRS	SIZE (MBTU)	OPER HRS	SIZE (MBTU)	OPER HRS	SIZE (MBTU)	OPER HRS
HW-BOILER	0.022	0.817	2 3 9	1.800	8760						
HERM-REC-CHLR	0.108	0.791	8 18 17	1.100	3115						

EQUIPMENT TOTALS

HW-BOILER	74.7		
NOMINAL SIZE (MBTU)		1.800	
NUMBER INSTALLED			1
FIRST COST (K\$)	52.6		52.6
ANNUAL COST (K\$)	1.0		1.0
CYCLICAL COST (K\$)	21.2		21.2
-----TOTAL----- (K\$)			74.7
HERM-REC-CHLR	30.0		
NOMINAL SIZE (MBTU)		1.100	
NUMBER INSTALLED			1
FIRST COST (K\$)	24.2		24.2
ANNUAL COST (K\$)	2.3		2.3
CYCLICAL COST (K\$)	3.6		3.6
-----TOTAL----- (K\$)			30.0
<hr/>			
EQUIPMENT TOTAL	104.8		

ENERGY TYPE	ELECTRICITY	NATURAL-GAS
IN SITE MBTU -		
CATEGORY OF USE		
SPACE HEAT	30.62	576.08
SPACE COOL	532.92	0.00
HVAC AUX	195.74	0.00
DOM HOT WTR	0.00	0.00
AUX SOLAR	0.00	0.00
LIGHTS	230.36	0.00
VERT TRANS	0.00	0.00
MISC EQUIP	6.86	0.00
TOTAL	996.50	576.08

TOTAL SITE ENERGY 1572.57 MBTU 104.2 KBTU/SQFT-YR GROSS-AREA 104.2 KBTU/SQFT-YR NET-AREA
 TOTAL SOURCE ENERGY 3568.54 MBTU 236.3 KBTU/SQFT-YR GROSS-AREA 236.3 KBTU/SQFT-YR NET-AREA

PERCENT OF HOURS ANY SYSTEM ZONE OUTSIDE OF THROTTILING RANGE = 0.6
 PERCENT OF HOURS ANY PLANT LOAD NOT SATISFIED = 0.0

NOTE ELECTRICITY AND/OR FUEL USED TO GENERATE ELECTRICITY IS APPORTIONED BASED
 ON THE YEARLY DEMAND. ALL OTHER ENERGY TYPES ARE APPORTIONED HOURLY.

MDDHH	HW-BOILE R LOAD BTU/HR	HW-BOILE R ELECTRIC USE BTU/HR	HW-BOILE R FUEL USE BTU/HR	HERM-REC -CHLR LOAD BTU/HR	HERM-REC -CHLR ELECTRIC USE BTU/HR	HERM-REC -CHLR NOM CAP RUNNING BTU/HR
	---- (1)	---- (3)	---- (4)	---- (1)	---- (3)	---- (7)
MONTHLY SUMMARY (JAN)						
MN	5404.	476.	8831.	0.	0.	0.
MX	667774.	39600.	993283.	26142.	47185.	1100000.
SM	81240776.	7013908.	132073824.	4675559.	8440442.	322300000.
AV	109195.	9427.	177519.	6284.	11345.	433199.
MONTHLY SUMMARY (FEB)						
MN	5404.	476.	8831.	0.	0.	0.
MX	816536.	39600.	1166466.	30740.	55481.	1100000.
SM	72302064.	6070804.	116664912.	5002117.	9029892.	337700000.
AV	107592.	9034.	173609.	7444.	13437.	502530.
MONTHLY SUMMARY (MAR)						
MN	5404.	476.	8831.	0.	0.	0.
MX	537305.	39600.	839391.	22426.	40481.	1100000.
SM	43973360.	3840003.	71709736.	4556791.	8226723.	308000000.
AV	59104.	5161.	96384.	6125.	11057.	413979.
MONTHLY SUMMARY (APR)						
MN	5404.	476.	8831.	0.	0.	0.
MX	471113.	39600.	760597.	19545.	35282.	1100000.
SM	19515422.	1715170.	31880022.	2507513.	4530143.	167200000.
AV	27105.	2382.	44278.	3483.	6292.	232222.
MONTHLY SUMMARY (MAY)						
MN	5404.	476.	8831.	0.	0.	0.
MX	28998.	2552.	47387.	479729.	563749.	1100000.
SM	5129734.	451417.	8382701.	32835552.	52814620.	196900000.
AV	6895.	607.	11267.	44134.	70987.	264651.
MONTHLY SUMMARY (JUN)						
MN	5404.	476.	8831.	0.	0.	0.
MX	12349.	1087.	20181.	781853.	648142.	1100000.
SM	4006659.	352586.	6547441.	69389608.	97956272.	324500000.
AV	5565.	490.	9094.	96374.	136050.	450694.
MONTHLY SUMMARY (JUL)						
MN	5404.	476.	8831.	0.	0.	0.
MX	6621.	583.	10820.	756789.	651970.	1100000.
SM	4137954.	364140.	6761997.	95602144.	127870128.	419100000.
AV	5562.	489.	9089.	128498.	171868.	563306.

	HW-BOILE R LOAD BTU/HR	HW-BOILE R ELECTRIC USE BTU/HR	HW-BOILE R FUEL USE BTU/HR	HERM-REC -CHLR LOAD BTU/HR	HERM-REC -CHLR ELECTRIC USE BTU/HR	HERM-REC -CHLR NOM CAP RUNNING BTU/HR
	----(1)	----(3)	----(4)	----(1)	----(3)	----(7)
MONTHLY SUMMARY (AUG)						
MN	5404.	476.	8831.	0.	0.	0.
MX	6576.	579.	10746.	790780.	662409.	1100000.
SM	4108527.	361550.	6713906.	75177400.	101359864.	356400000.
AV	5522.	486.	9024.	101045.	136236.	479032.
MONTHLY SUMMARY (SEP)						
MN	5404.	476.	8831.	0.	0.	0.
MX	16519.	1454.	26994.	693999.	636309.	1100000.
SM	4093986.	360271.	6690145.	58078932.	80509144.	260700000.
AV	5686.	500.	9292.	80665.	111818.	362083.
MONTHLY SUMMARY (OCT)						
MN	5404.	476.	8831.	0.	0.	0.
MX	352116.	30986.	575407.	388555.	535584.	1100000.
SM	10348219.	910643.	16910434.	15200175.	26724046.	151800000.
AV	13909.	1224.	22729.	20430.	35919.	204032.
MONTHLY SUMMARY (NOV)						
MN	5404.	476.	8831.	0.	0.	0.
MX	529273.	39600.	829855.	21120.	38124.	1100000.
SM	30234436.	2650183.	49354912.	3368563.	6081005.	229900000.
AV	41992.	3681.	68548.	4679.	8446.	319306.
MONTHLY SUMMARY (DEC)						
MN	5404.	476.	8831.	0.	0.	0.
MX	715767.	39600.	1049422.	30435.	54931.	1100000.
SM	75164760.	6527661.	122388752.	5194174.	9376595.	352000000.
AV	101028.	8774.	164501.	6981.	12603.	473118.
YEARLY SUMMARY						
MN	5404.	476.	8831.	0.	0.	0.
MX	816536.	39600.	1166466.	790780.	662409.	1100000.
SM	354255904.	30618332.	576078784.	371588544.	532918880.	3426499840.
AV	40440.	3495.	65762.	42419.	60835.	391153.

MDDHH	AHU-1	AHU-1	AHU-1	AHU-1	AHU-1	AHU-2	AHU-2	AHU-2
	TOT HTG COIL PWR BTU/HR	TOT CLG COIL PWR BTU/HR	SUPPLY ELECTRIC KW	COOLING CAPACITY BTU/HR	HEATING CAPACITY BTU/HR	TOT HTG COIL PWR BTU/HR	TOT CLG COIL PWR BTU/HR	SUPPLY ELECTRIC KW
	---- (5)	---- (6)	----(49)	----(70)	---- (78)	---- (5)	---- (6)	----(49)
MONTHLY SUMMARY (JAN)								
MN	-50886.	0.	0.000	0.	-117423.	-51471.	0.	0.000
MX	0.	0.	1.622	1459493.	0.	0.	0.	1.630
SM	-2276335.	0.	441.293	49549024.	-31939120.	-2331578.	0.	443.414
AV	-3060.	0.	0.593	66598.	-42929.	-3134.	0.	0.596
MONTHLY SUMMARY (FEB)								
MN	-58752.	0.	0.000	0.	-117423.	-59407.	0.	0.000
MX	0.	0.	1.622	2042772.	0.	0.	0.	1.630
SM	-2469587.	0.	405.600	37834808.	-29355810.	-2524785.	0.	407.550
AV	-3675.	0.	0.604	56302.	-43684.	-3757.	0.	0.606
MONTHLY SUMMARY (MAR)								
MN	-45901.	0.	0.000	0.	-117423.	-44619.	0.	0.000
MX	0.	0.	1.622	2072915.	0.	0.	0.	1.630
SM	-1128948.	0.	330.970	47176208.	-23954342.	-1162115.	0.	334.191
AV	-1517.	0.	0.445	63409.	-32197.	-1562.	0.	0.449
MONTHLY SUMMARY (APR)								
MN	-25243.	0.	0.000	0.	-117423.	-25695.	0.	0.000
MX	0.	0.	1.622	1941406.	0.	0.	0.	1.630
SM	-225741.	0.	295.277	52608124.	-21371030.	-234642.	0.	296.696
AV	-314.	0.	0.410	73067.	-29682.	-326.	0.	0.412
MONTHLY SUMMARY (MAY)								
MN	0.	0.	0.000	0.	0.	0.	0.	0.000
MX	0.	68796.	1.622	660801.	0.	0.	68825.	1.630
SM	0.	6113818.	394.243	19121142.	0.	0.	6101479.	397.769
AV	0.	8217.	0.530	25700.	0.	0.	8201.	0.535
MONTHLY SUMMARY (JUN)								
MN	0.	0.	0.000	0.	0.	0.	0.	0.000
MX	0.	83468.	1.622	141574.	0.	0.	83702.	1.630
SM	0.	9167223.	350.438	18150528.	0.	0.	9188675.	352.123
AV	0.	12732.	0.487	25209.	0.	0.	12762.	0.489
MONTHLY SUMMARY (JUL)								
MN	0.	0.	0.000	0.	0.	0.	0.	0.000
MX	0.	83446.	1.622	155457.	0.	0.	83733.	1.630
SM	0.	11229095.	410.467	21752836.	0.	0.	11244060.	412.441
AV	0.	15093.	0.552	29238.	0.	0.	15113.	0.554

	AHU-1	AHU-1	AHU-1	AHU-1	AHU-1	AHU-2	AHU-2	AHU-2
	TOT HTG COIL PWR BTU/HR	TOT CLG COIL PWR BTU/HR	SUPPLY ELECTRIC KW	COOLING CAPACITY BTU/HR	HEATING CAPACITY BTU/HR	TOT HTG COIL PWR BTU/HR	TOT CLG COIL PWR BTU/HR	SUPPLY ELECTRIC KW
	---- (5)	---- (6)	----(49)	---- (70)	---- (78)	---- (5)	---- (6)	----(49)
MONTHLY SUMMARY (AUG)								
MN	0.	0.	0.000	0.	0.	0.	0.	0.000
MK	0.	85114.	1.622	158964.	0.	0.	85424.	1.630
SM	0.	9312612.	361.795	19198978.	0.	0.	9321677.	363.535
AV	0.	12517.	0.486	25805.	0.	0.	12529.	0.489
MONTHLY SUMMARY (SEP)								
MN	0.	0.	0.000	0.	0.	0.	0.	0.000
MK	0.	79316.	1.622	813468.	0.	0.	79506.	1.630
SM	0.	8505082.	335.837	17618996.	0.	0.	8491035.	339.082
AV	0.	11813.	0.466	24471.	0.	0.	11793.	0.471
MONTHLY SUMMARY (OCT)								
MN	-14975.	0.	0.000	0.	-117423.	-15497.	0.	0.000
MK	0.	63285.	1.622	904609.	0.	0.	63255.	1.630
SM	-51475.	4252056.	352.061	20906154.	-9159013.	-53722.	4233379.	353.753
AV	-69.	5715.	0.473	28100.	-12311.	-72.	5690.	0.475
MONTHLY SUMMARY (NOV)								
MN	-48099.	0.	0.000	0.	-117423.	-48653.	0.	0.000
MK	0.	0.	1.622	1482034.	0.	0.	0.	1.630
SM	-677502.	0.	270.941	45252084.	-19609682.	-699155.	0.	272.243
AV	-941.	0.	0.376	62850.	-27236.	-971.	0.	0.378
MONTHLY SUMMARY (DEC)								
MN	-49270.	0.	0.000	0.	-117423.	-49817.	0.	0.000
MK	0.	0.	1.622	1479024.	0.	0.	0.	1.630
SM	-2115462.	0.	438.048	52097352.	-31704274.	-2154086.	0.	445.045
AV	-2843.	0.	0.589	70023.	-42613.	-2895.	0.	0.598
YEARLY SUMMARY								
MN	-58752.	0.	0.000	0.	-117423.	-59407.	0.	0.000
MK	0.	85114.	1.622	2072915.	0.	0.	85424.	1.630
SM	-8945049.	48579888.	4386.969	401266208.	-167093280.	-9160082.	48580308.	4417.842
AV	-1021.	5546.	0.501	45807.	-19075.	-1046.	5546.	0.504

MDDHH	AHU-2	AHU-2	AHU-3	AHU-3	AHU-3	AHU-3	AHU-3	AHU-4
	COOLING CAPACITY BTU/HR	HEATING CAPACITY BTU/HR	TOT HTG COIL PWR BTU/HR	TOT CLG COIL PWR BTU/HR	SUPPLY ELECTRIC KW	COOLING CAPACITY BTU/HR	HEATING CAPACITY BTU/HR	TOT HTG COIL PWR BTU/HR
	---- (70)	---- (78)	---- (5)	---- (6)	---- (49)	---- (70)	---- (78)	---- (5)
MONTHLY SUMMARY (JAN)								
MN	0.	-117988.	-43104.	0.	0.000	0.	-78470.	-25877.
MX	1452617.	0.	0.	0.	1.084	1477994.	0.	0.
SM	49255688.	-32092664.	-5834580.	0.	429.343	63697052.	-31074254.	-2474160.
AV	66204.	-43135.	-7842.	0.	0.577	85614.	-41766.	-3325.
MONTHLY SUMMARY (FEB)								
MN	0.	-117988.	-46252.	0.	0.000	0.	-78470.	-30485.
MX	2037496.	0.	0.	0.	1.084	1884283.	0.	0.
SM	37628244.	-29496934.	-4981377.	0.	383.807	47382632.	-27778494.	-2179679.
AV	55994.	-43894.	-7413.	0.	0.571	70510.	-41337.	-3244.
MONTHLY SUMMARY (MAR)								
MN	0.	-117988.	-35958.	0.	0.000	0.	-78470.	-22384.
MX	2068162.	0.	0.	0.	1.084	1898961.	0.	0.
SM	46976188.	-24187486.	-2802870.	0.	365.375	57481452.	-26444500.	-1152709.
AV	63140.	-32510.	-3767.	0.	0.491	77260.	-35544.	-1549.
MONTHLY SUMMARY (APR)								
MN	0.	-117988.	-29130.	0.	0.000	0.	-78470.	-16977.
MX	1938510.	0.	0.	0.	1.084	1830696.	0.	0.
SM	52305412.	-21473768.	-912308.	0.	267.797	63970784.	-19382168.	-324597.
AV	72646.	-29825.	-1267.	0.	0.372	88848.	-26920.	-451.
MONTHLY SUMMARY (MAY)								
MN	0.	0.	0.	0.	0.000	0.	0.	0.
MX	656197.	0.	0.	49509.	1.084	988423.	0.	0.
SM	19241322.	0.	0.	2880373.	483.553	31134014.	0.	0.
AV	25862.	0.	0.	3871.	0.650	41847.	0.	0.
MONTHLY SUMMARY (JUN)								
MN	0.	0.	0.	0.	0.000	0.	0.	0.
MX	142530.	0.	0.	53935.	1.084	508095.	0.	0.
SM	18237592.	0.	0.	5054237.	273.218	15979297.	0.	0.
AV	25330.	0.	0.	7020.	0.379	22193.	0.	0.
MONTHLY SUMMARY (JUL)								
MN	0.	0.	0.	0.	0.000	0.	0.	0.
MX	156768.	0.	0.	54110.	1.084	133043.	0.	0.
SM	21849346.	0.	0.	6836545.	261.292	14288679.	0.	0.
AV	29367.	0.	0.	9189.	0.351	19205.	0.	0.

	AHU-2	AHU-2	AHU-3	AHU-3	AHU-3	AHU-3	AHU-3	AHU-4
	COOLING CAPACITY BTU/HR	HEATING CAPACITY BTU/HR	TOT HTG COIL PWR BTU/HR	TOT CLG COIL PWR BTU/HR	SUPPLY ELECTRIC KW	COOLING CAPACITY BTU/HR	HEATING CAPACITY BTU/HR	TOT HTG COIL PWR BTU/HR
	----(70)	----(78)	----(5)	----(6)	----(49)	----(70)	----(78)	----(5)
MONTHLY SUMMARY (AUG)								
MN	0.	0.	0.	0.	0.000	0.	0.	0.
MX	160370.	0.	0.	55927.	1.084	160208.	0.	0.
SM	19286398.	0.	0.	5279166.	212.503	11647227.	0.	0.
AV	25923.	0.	0.	7096.	0.286	15655.	0.	0.
MONTHLY SUMMARY (SEP)								
MN	0.	0.	0.	0.	0.000	0.	0.	0.
MX	808257.	0.	0.	53886.	1.084	1102097.	0.	0.
SM	17701508.	0.	0.	4985282.	308.997	18836400.	0.	0.
AV	24585.	0.	0.	6924.	0.429	26162.	0.	0.
MONTHLY SUMMARY (OCT)								
MN	0.	-117988.	-22362.	0.	0.000	0.	-78470.	-15255.
MX	899178.	0.	0.	51634.	1.084	1131800.	0.	0.
SM	20921116.	-9203044.	-239051.	1786322.	338.270	34750812.	-6826918.	-109789.
AV	28120.	-12370.	-321.	2401.	0.455	46708.	-9176.	-148.
MONTHLY SUMMARY (NOV)								
MN	0.	-117988.	-35387.	0.	0.000	0.	-78470.	-23747.
MX	1476581.	0.	0.	0.	1.084	1499063.	0.	0.
SM	45007992.	-19703954.	-2160854.	0.	308.997	54961344.	-22364042.	-901397.
AV	62511.	-27367.	-3001.	0.	0.429	76335.	-31061.	-1252.
MONTHLY SUMMARY (DEC)								
MN	0.	-117988.	-45514.	0.	0.000	0.	-78470.	-27443.
MX	1472271.	0.	0.	0.	1.084	1490160.	0.	0.
SM	51948916.	-32210650.	-4992241.	0.	438.017	67309968.	-31702012.	-2109662.
AV	69824.	-43294.	-6710.	0.	0.589	90470.	-42610.	-2836.
YEARLY SUMMARY								
MN	0.	-117988.	-46252.	0.	0.000	0.	-78470.	-30485.
MX	2068162.	0.	0.	55927.	1.084	1898961.	0.	0.
SM	400359744.	-168368512.	-21923278.	26821924.	4071.171	481439680.	-165572384.	-9251993.
AV	45703.	-19220.	-2503.	3062.	0.465	54959.	-18901.	-1056.

MDDHH	AHU-4	AHU-4	AHU-4	AHU-4	AHU-5	AHU-5	AHU-5	AHU-5
	TOT CLG COIL PWR BTU/HR	SUPPLY ELECTRIC KW	COOLING CAPACITY BTU/HR	HEATING CAPACITY BTU/HR	TOT HTG COIL PWR BTU/HR	TOT CLG COIL PWR BTU/HR	SUPPLY ELECTRIC KW	COOLING CAPACITY BTU/HR
	---- (6)	---- (49)	---- (70)	---- (78)	---- (5)	---- (6)	---- (49)	---- (70)
MONTHLY SUMMARY (JAN)								
MN	0.	0.000	0.	-53066.	-87889.	0.	0.000	0.
MX	0.	0.733	864643.	0.	0.	0.	1.521	1330028.
SM	0.	255.887	33619076.	-18520124.	-11603826.	0.	585.585	52153292.
AV	0.	0.344	45187.	-24893.	-15597.	0.	0.787	70099.
MONTHLY SUMMARY (FEB)								
MN	0.	0.000	0.	-53066.	-87782.	0.	0.000	0.
MX	0.	0.733	1142909.	0.	0.	0.	1.521	1873524.
SM	0.	231.691	25937396.	-16768935.	-9851069.	0.	529.308	40032872.
AV	0.	0.345	38597.	-24954.	-14659.	0.	0.788	59573.
MONTHLY SUMMARY (MAR)								
MN	0.	0.000	0.	-53066.	-69277.	0.	0.000	0.
MX	0.	0.733	1154197.	0.	0.	0.	1.521	1897530.
SM	0.	214.094	31427390.	-15495346.	-6074435.	0.	498.888	49138148.
AV	0.	0.288	42241.	-20827.	-8165.	0.	0.671	66046.
MONTHLY SUMMARY (APR)								
MN	0.	0.000	0.	-53066.	-53684.	0.	0.000	0.
MX	0.	0.733	1097531.	0.	0.	0.	1.521	1876362.
SM	0.	145.174	33635736.	-10507119.	-2183897.	0.	360.477	50905564.
AV	0.	0.202	46716.	-14593.	-3033.	0.	0.501	70702.
MONTHLY SUMMARY (MAY)								
MN	0.	0.000	0.	0.	0.	0.	0.000	0.
MX	31623.	0.733	424397.	0.	0.	53641.	1.521	861979.
SM	2294725.	248.555	13574094.	0.	0.	2761339.	708.786	38688424.
AV	3084.	0.334	18245.	0.	0.	3711.	0.953	52001.
MONTHLY SUMMARY (JUN)								
MN	0.	0.000	0.	0.	0.	0.	0.000	0.
MX	37786.	0.733	280880.	0.	0.	71545.	1.521	408145.
SM	3775925.	164.970	9337267.	0.	0.	5970101.	352.872	18119092.
AV	5244.	0.229	12968.	0.	0.	8292.	0.490	25165.
MONTHLY SUMMARY (JUL)								
MN	0.	0.000	0.	0.	0.	0.	0.000	0.
MX	36676.	0.733	82421.	0.	0.	67656.	1.521	137624.
SM	4928520.	182.567	9908554.	0.	0.	8449266.	331.578	16360367.
AV	6624.	0.245	13318.	0.	0.	11357.	0.446	21990.

	AHU-4	AHU-4	AHU-4	AHU-4	AHU-5	AHU-5	AHU-5	AHU-5
	TOT CLG COIL PWR BTU/HR	SUPPLY ELECTRIC KW	COOLING CAPACITY BTU/HR	HEATING CAPACITY BTU/HR	TOT HTG COIL PWR BTU/HR	TOT CLG COIL PWR BTU/HR	SUPPLY ELECTRIC KW	COOLING CAPACITY BTU/HR
	---- (6)	----(49)	----(70)	----(78)	---- (5)	---- (6)	----(49)	----(70)
MONTHLY SUMMARY (AUG)								
MN	0.	0.000	0.	0.	0.	0.	0.000	0.
MX	38987.	0.733	81758.	0.	0.	72825.	1.521	135759.
SM	3878122.	147.373	8003235.	0.	0.	6259410.	275.301	13286844.
AV	5213.	0.198	10757.	0.	0.	8413.	0.370	17859.
MONTHLY SUMMARY (SEP)								
MN	0.	0.000	0.	0.	0.	0.	0.000	0.
MX	36502.	0.733	628088.	0.	0.	68671.	1.521	934031.
SM	3528242.	172.302	10207557.	0.	0.	5519458.	480.636	25129428.
AV	4900.	0.239	14177.	0.	0.	7666.	0.668	34902.
MONTHLY SUMMARY (OCT)								
MN	0.	0.000	0.	-53066.	-49113.	0.	0.000	0.
MX	33688.	0.733	648428.	0.	0.	55855.	1.521	1391680.
SM	1422035.	200.164	17089798.	-4245301.	-757159.	1439088.	550.602	42514684.
AV	1911.	0.269	22970.	-5706.	-1018.	1934.	0.740	57143.
MONTHLY SUMMARY (NOV)								
MN	0.	0.000	0.	-53066.	-67836.	0.	0.000	0.
MX	0.	0.733	878199.	0.	0.	0.	1.521	1372426.
SM	0.	175.235	29982412.	-12682835.	-4646847.	0.	430.443	47175184.
AV	0.	0.243	41642.	-17615.	-6454.	0.	0.598	65521.
MONTHLY SUMMARY (DEC)								
MN	0.	0.000	0.	-53066.	-81512.	0.	0.000	0.
MX	0.	0.733	873078.	0.	0.	0.	1.521	1349140.
SM	0.	259.553	35365680.	-18785454.	-10222800.	0.	594.711	54677208.
AV	0.	0.349	47535.	-25249.	-13740.	0.	0.799	73491.
YEARLY SUMMARY								
MN	0.	0.000	0.	-53066.	-87889.	0.	0.000	0.
MX	38987.	0.733	1154197.	0.	0.	72825.	1.521	1897530.
SM	19827568.	2397.564	258088192.	-97005120.	-45340036.	30398662.	5699.188	448181152.
AV	2263.	0.274	29462.	-11074.	-5176.	3470.	0.651	51162.

MMDDHH	AHU-5	AHU-6	AHU-6	AHU-6	AHU-6	AHU-6	AHU-7	AHU-7
	HEATING CAPACITY BTU/HR	TOT HTG COIL PWR BTU/HR	TOT CLG COIL PWR BTU/HR	SUPPLY ELECTRIC KW	COOLING CAPACITY BTU/HR	HEATING CAPACITY BTU/HR	TOT HTG COIL PWR BTU/HR	TOT CLG COIL PWR BTU/HR
	---- (78)	---- (5)	---- (6)	---- (49)	---- (70)	---- (78)	---- (5)	---- (6)
MONTHLY SUMMARY (JAN)								
MN	-110084.	-43628.	0.	0.000	0.	-62099.	-26744.	0.
MX	0.	0.	0.	0.858	1047889.	0.	0.	0.
SM	-42382444.	-4759774.	0.	311.454	42115208.	-22541872.	-900373.	0.
AV	-56966.	-6398.	0.	0.419	56606.	-30298.	-1210.	0.
MONTHLY SUMMARY (FEB)								
MN	-110084.	-42434.	0.	0.000	0.	-62099.	-31151.	0.
MX	0.	0.	0.	0.858	1370326.	0.	0.	0.
SM	-38309328.	-4074297.	0.	283.998	31981028.	-20554710.	-1039427.	0.
AV	-57008.	-6063.	0.	0.423	47591.	-30587.	-1547.	0.
MONTHLY SUMMARY (MAR)								
MN	-110084.	-34676.	0.	0.000	0.	-62099.	-24005.	0.
MX	0.	0.	0.	0.858	1382481.	0.	0.	0.
SM	-36107640.	-2437886.	0.	265.980	38952420.	-19250634.	-421069.	0.
AV	-48532.	-3277.	0.	0.358	52355.	-25875.	-566.	0.
MONTHLY SUMMARY (APR)								
MN	-110084.	-25453.	0.	0.000	0.	-62099.	-11427.	0.
MX	0.	0.	0.	0.858	1349645.	0.	0.	0.
SM	-26089972.	-833012.	0.	189.618	42334424.	-13723841.	-74644.	0.
AV	-36236.	-1157.	0.	0.263	58798.	-19061.	-104.	0.
MONTHLY SUMMARY (MAY)								
MN	0.	0.	0.	0.000	0.	0.	0.	0.
MX	0.	0.	33282.	0.858	523409.	0.	0.	48761.
SM	0.	0.	1957704.	364.650	21824922.	0.	0.	4687420.
AV	0.	0.	2631.	0.490	29335.	0.	0.	6300.
MONTHLY SUMMARY (JUN)								
MN	0.	0.	0.	0.000	0.	0.	0.	0.
MX	0.	0.	42083.	0.858	345656.	0.	0.	55662.
SM	0.	0.	3715697.	191.334	10394907.	0.	0.	6444027.
AV	0.	0.	5161.	0.266	14437.	0.	0.	8950.
MONTHLY SUMMARY (JUL)								
MN	0.	0.	0.	0.000	0.	0.	0.	0.
MX	0.	0.	40105.	0.858	83674.	0.	0.	56026.
SM	0.	0.	5008146.	189.618	9660348.	0.	0.	7749919.
AV	0.	0.	6731.	0.255	12984.	0.	0.	10417.

	AHU-5	AHU-6	AHU-6	AHU-6	AHU-6	AHU-6	AHU-7	AHU-7
	HEATING CAPACITY BTU/HR	TOT HTG COIL PWR BTU/HR	TOT CLG COIL PWR BTU/HR	SUPPLY ELECTRIC KW	COOLING CAPACITY BTU/HR	HEATING CAPACITY BTU/HR	TOT HTG COIL PWR BTU/HR	TOT CLG COIL PWR BTU/HR
	----(78)	----(5)	----(6)	----(49)	----(70)	----(78)	----(5)	----(6)
MONTHLY SUMMARY (AUG)								
MN	0.	0.	0.	0.000	0.	0.	0.	0.
MX	0.	0.	42362.	0.858	83730.	0.	0.	56970.
SM	0.	0.	3767003.	151.008	7626176.	0.	0.	6492046.
AV	0.	0.	5063.	0.203	10250.	0.	0.	8726.
MONTHLY SUMMARY (SEP)								
MN	0.	0.	0.	0.000	0.	0.	0.	0.
MX	0.	0.	40524.	0.858	767909.	0.	0.	53410.
SM	0.	0.	3500538.	248.820	14672457.	0.	0.	6191503.
AV	0.	0.	4862.	0.346	20378.	0.	0.	8599.
MONTHLY SUMMARY (OCT)								
MN	-110084.	-24693.	0.	0.000	0.	-62099.	-4643.	0.
MX	0.	0.	37353.	0.858	853331.	0.	0.	45341.
SM	-10127752.	-288087.	1132021.	283.140	26313046.	-5402597.	-12671.	3575378.
AV	-13613.	-387.	1522.	0.381	35367.	-7262.	-17.	4806.
MONTHLY SUMMARY (NOV)								
MN	-110084.	-35204.	0.	0.000	0.	-62099.	-26326.	0.
MX	0.	0.	0.	0.858	1066809.	0.	0.	0.
SM	-31153850.	-1866116.	0.	223.938	37450536.	-16207792.	-245787.	0.
AV	-43269.	-2592.	0.	0.311	52015.	-22511.	-341.	0.
MONTHLY SUMMARY (DEC)								
MN	-110084.	-43125.	0.	0.000	0.	-62099.	-25864.	0.
MX	0.	0.	0.	0.858	1058007.	0.	0.	0.
SM	-43042952.	-4121151.	0.	314.028	43182752.	-22728168.	-867278.	0.
AV	-57853.	-5539.	0.	0.422	58041.	-30549.	-1166.	0.
YEARLY SUMMARY								
MN	-110084.	-43628.	0.	0.000	0.	-62099.	-31151.	0.
MX	0.	0.	42362.	0.858	1382481.	0.	0.	56970.
SM	-227213952.	-18380322.	19081110.	3017.586	326508224.	-120409616.	-3561249.	35140288.
AV	-25938.	-2098.	2178.	0.344	37273.	-13745.	-407.	4011.

MDDHH	AHU-7	AHU-7	AHU-7	AHU-8	AHU-8	AHU-8	AHU-8	AHU-8
	SUPPLY ELECTRIC KW	COOLING CAPACITY BTU/HR	HEATING CAPACITY BTU/HR	TOT HTG COIL FWR BTU/HR	TOT CLG COIL FWR BTU/HR	SUPPLY ELECTRIC KW	COOLING CAPACITY BTU/HR	HEATING CAPACITY BTU/HR
	----(49)	----(70)	----(78)	----(5)	----(6)	----(49)	----(70)	----(78)
MONTHLY SUMMARY (JAN)								
MN	0.000	0.	-75648.	-134152.	0.	0.000	0.	-235411.
MX	1.045	1245623.	0.	0.	0.	3.253	3562566.	0.
SM	262.345	44547792.	-18987560.	-20009170.	0.	1372.597	155939808.	-99343416.
AV	0.353	59876.	-25521.	-26894.	0.	1.845	209597.	-133526.
MONTHLY SUMMARY (FEB)								
MN	0.000	0.	-75648.	-141497.	0.	0.000	0.	-235411.
MX	1.045	1634441.	0.	0.	0.	3.253	4734939.	0.
SM	245.622	33760628.	-17777196.	-15373843.	0.	1206.715	114677528.	-87337464.
AV	0.366	50239.	-26454.	-22878.	0.	1.796	170651.	-129966.
MONTHLY SUMMARY (MAR)								
MN	0.000	0.	-75648.	-101042.	0.	0.000	0.	-235411.
MX	1.045	1648732.	0.	0.	0.	3.253	4786754.	0.
SM	196.498	41712888.	-14221755.	-7848928.	0.	1070.106	132738568.	-77450200.
AV	0.264	56066.	-19115.	-10550.	0.	1.438	178412.	-104100.
MONTHLY SUMMARY (APR)								
MN	0.000	0.	-75648.	-87981.	0.	0.000	0.	-235411.
MX	1.045	1515071.	0.	0.	0.	3.253	4674361.	0.
SM	199.633	49410828.	-14448698.	-2382002.	0.	722.077	143199648.	-52261240.
AV	0.277	68626.	-20068.	-3308.	0.	1.003	198888.	-72585.
MONTHLY SUMMARY (MAY)								
MN	0.000	0.	0.	0.	0.	0.000	0.	0.
MX	1.045	615775.	0.	0.	101128.	3.253	1737548.	0.
SM	247.712	13359452.	0.	0.	7102718.	1226.231	62225740.	0.
AV	0.333	17956.	0.	0.	9547.	1.648	83637.	0.
MONTHLY SUMMARY (JUN)								
MN	0.000	0.	0.	0.	0.	0.000	0.	0.
MX	1.045	107593.	0.	0.	125891.	3.253	1147124.	0.
SM	241.441	13042985.	0.	0.	14664257.	822.908	40985208.	0.
AV	0.335	18115.	0.	0.	20367.	1.143	56924.	0.
MONTHLY SUMMARY (JUL)								
MN	0.000	0.	0.	0.	0.	0.000	0.	0.
MX	1.045	108658.	0.	0.	125984.	3.253	245617.	0.
SM	287.430	15803807.	0.	0.	19331614.	923.739	43754780.	0.
AV	0.386	21242.	0.	0.	25983.	1.242	58810.	0.

	AHU-7	AHU-7	AHU-7	AHU-8	AHU-8	AHU-8	AHU-8	AHU-8
	SUPPLY ELECTRIC KW	COOLING CAPACITY BTU/HR	HEATING CAPACITY BTU/HR	TOT HTG COIL PWR BTU/HR	TOT CLG COIL PWR BTU/HR	SUPPLY ELECTRIC KW	COOLING CAPACITY BTU/HR	HEATING CAPACITY BTU/HR
	---- (49)	---- (70)	---- (78)	---- (5)	---- (6)	---- (49)	---- (70)	---- (78)
MONTHLY SUMMARY (AUG)								
MN	0.000	0.	0.	0.	0.	0.000	0.	0.
MX	1.045	113790.	0.	0.	130288.	3.253	230015.	0.
SM	252.938	13949938.	0.	0.	14679581.	816.403	38747344.	0.
AV	0.340	18750.	0.	0.	19731.	1.097	52080.	0.
MONTHLY SUMMARY (SEP)								
MN	0.000	0.	0.	0.	0.	0.000	0.	0.
MX	1.045	121153.	0.	0.	121162.	3.253	2577857.	0.
SM	232.034	12382116.	0.	0.	10774463.	962.770	48711188.	0.
AV	0.322	17197.	0.	0.	14965.	1.337	67654.	0.
MONTHLY SUMMARY (OCT)								
MN	0.000	0.	-75648.	-71174.	0.	0.000	0.	-235411.
MX	1.045	608181.	0.	0.	104931.	3.253	3636492.	0.
SM	216.356	14126702.	-6203107.	-966095.	3245193.	1164.431	89263176.	-22599454.
AV	0.291	18988.	-8338.	-1299.	4362.	1.565	119977.	-30376.
MONTHLY SUMMARY (NOV)								
MN	0.000	0.	-75648.	-99195.	0.	0.000	0.	-235411.
MX	1.045	1242762.	0.	0.	0.	3.253	3636683.	0.
SM	160.961	40024020.	-11649737.	-7192128.	0.	975.780	129943760.	-70623288.
AV	0.224	55589.	-16180.	-9989.	0.	1.355	180477.	-98088.
MONTHLY SUMMARY (DEC)								
MN	0.000	0.	-75648.	-130561.	0.	0.000	0.	-235411.
MX	1.045	1262753.	0.	0.	0.	3.253	3597469.	0.
SM	269.662	47239088.	-19517092.	-17428504.	0.	1401.871	154378592.	-101462120.
AV	0.362	63493.	-26233.	-23425.	0.	1.884	207498.	-136374.
YEARLY SUMMARY								
MN	0.000	0.	-75648.	-141497.	0.	0.000	0.	-235411.
MX	1.045	1648732.	0.	0.	130288.	3.253	4786754.	0.
SM	2812.634	339360256.	-102805136.	-71200672.	69797832.	12665.627	1154565248.	-511077184.
AV	0.321	38740.	-11736.	-8128.	7968.	1.446	131800.	-58342.

MDDH	AHU-9	AHU-9	AHU-9	AHU-9	AHU-9
	TOT HTG COIL PWR BTU/HR	TOT CLG COIL PWR BTU/HR	SUPPLY ELECTRIC KW	COOLING CAPACITY BTU/HR	HEATING CAPACITY BTU/HR
	---- (5)	---- (6)	---- (49)	---- (70)	---- (78)
MONTHLY SUMMARY (JAN)					
MN	-26748.	0.	0.000	0.	-45727.
MX	0.	0.	0.632	33797.	0.
SM	-1137334.	0.	154.791	4824630.	-11203190.
AV	-1529.	0.	0.208	6485.	-15058.
MONTHLY SUMMARY (FEB)					
MN	-29458.	0.	0.000	0.	-45727.
MX	0.	0.	0.632	66045.	0.
SM	-1177086.	0.	140.260	4360414.	-10151463.
AV	-1752.	0.	0.209	6489.	-15106.
MONTHLY SUMMARY (MAR)					
MN	-23381.	0.	0.000	0.	-45727.
MX	0.	0.	0.632	71206.	0.
SM	-497835.	0.	114.356	3870784.	-8276643.
AV	-669.	0.	0.154	5203.	-11125.
MONTHLY SUMMARY (APR)					
MN	-10001.	0.	0.000	0.	-45727.
MX	0.	0.	0.632	91226.	0.
SM	-78328.	0.	114.988	4500585.	-8322370.
AV	-109.	0.	0.160	6251.	-11559.
MONTHLY SUMMARY (MAY)					
MN	0.	0.	0.000	0.	0.
MX	0.	18823.	0.632	32193.	0.
SM	0.	1710362.	127.624	4640528.	0.
AV	0.	2299.	0.172	6237.	0.
MONTHLY SUMMARY (JUN)					
MN	0.	0.	0.000	0.	0.
MX	0.	23854.	0.632	34165.	0.
SM	0.	3064244.	133.942	5541337.	0.
AV	0.	4256.	0.186	7696.	0.
MONTHLY SUMMARY (JUL)					
MN	0.	0.	0.000	0.	0.
MX	0.	23846.	0.632	36451.	0.
SM	0.	3810877.	160.477	6888468.	0.
AV	0.	5122.	0.216	9259.	0.

	AHU-9	AHU-9	AHU-9	AHU-9	AHU-9
	TOT HTG COIL PWR BTU/HR	TOT CLG COIL PWR BTU/HR	SUPPLY ELECTRIC KW	COOLING CAPACITY BTU/HR	HEATING CAPACITY BTU/HR
	---- (5)	---- (6)	---- (49)	---- (70)	---- (78)
MONTHLY SUMMARY (AUG)					
MN	0.	0.	0.000	0.	0.
MK	0.	24804.	0.632	34902.	0.
SM	0.	3171028.	137.732	5886971.	0.
AV	0.	4262.	0.185	7913.	0.
MONTHLY SUMMARY (SEP)					
MN	0.	0.	0.000	0.	0.
MK	0.	23796.	0.632	33703.	0.
SM	0.	2684981.	124.465	4842981.	0.
AV	0.	3729.	0.173	6726.	0.
MONTHLY SUMMARY (OCT)					
MN	-3448.	0.	0.000	0.	-45727.
MK	0.	15913.	0.632	30042.	0.
SM	-11834.	996247.	126.992	4456996.	-3566730.
AV	-16.	1339.	0.171	5991.	-4794.
MONTHLY SUMMARY (NOV)					
MN	-24174.	0.	0.000	0.	-45727.
MK	0.	0.	0.632	46801.	0.
SM	-305927.	0.	90.347	3371796.	-6539005.
AV	-425.	0.	0.125	4683.	-9082.
MONTHLY SUMMARY (DEC)					
MN	-27524.	0.	0.000	0.	-45727.
MK	0.	0.	0.632	39030.	0.
SM	-1042228.	0.	159.214	4974340.	-11523281.
AV	-1401.	0.	0.214	6686.	-15488.
YEARLY SUMMARY					
MN	-29458.	0.	0.000	0.	-45727.
MK	0.	24804.	0.632	91226.	0.
SM	-4250571.	15437737.	1585.187	58159828.	-59582676.
AV	-485.	1762.	0.181	6639.	-6802.

MDDHH	FC-1	FC-1	FC-1	FC-1	FC-1
	TOT HTG COIL PWR BTU/HR	TOT CLG COIL PWR BTU/HR	SUPPLY ELECTRIC KW	COOLING CAPACITY BTU/HR	HEATING CAPACITY BTU/HR
	---- (5)	---- (6)	----(49)	----(70)	----(78)
MONTHLY SUMMARY (JAN)					
MN	0.	0.	0.090	27165.	0.
MX	0.	10627.	0.090	40223.	0.
SM	0.	72633.	15.261	5213129.	0.
AV	0.	430.	0.090	30847.	0.
MONTHLY SUMMARY (FEB)					
MN	0.	0.	0.090	27154.	0.
MX	0.	5156.	0.090	42051.	0.
SM	0.	59725.	14.087	4921567.	0.
AV	0.	383.	0.090	31549.	0.
MONTHLY SUMMARY (MAR)					
MN	0.	0.	0.090	27154.	0.
MX	0.	6911.	0.090	32866.	0.
SM	0.	117335.	15.261	4764301.	0.
AV	0.	694.	0.090	28191.	0.
MONTHLY SUMMARY (APR)					
MN	0.	0.	0.090	27154.	0.
MX	0.	4030.	0.090	30632.	0.
SM	0.	117087.	16.435	5130150.	0.
AV	0.	643.	0.090	28188.	0.
MONTHLY SUMMARY (MAY)					
MN	0.	0.	0.090	28449.	0.
MX	0.	0.	0.090	61093.	0.
SM	0.	0.	14.087	6386861.	0.
AV	0.	0.	0.090	40941.	0.
MONTHLY SUMMARY (JUN)					
MN	0.	0.	0.090	31883.	0.
MX	0.	0.	0.090	93779.	0.
SM	0.	0.	15.261	9202484.	0.
AV	0.	0.	0.090	54453.	0.
MONTHLY SUMMARY (JUL)					
MN	0.	0.	0.090	39899.	0.
MX	0.	0.	0.090	96027.	0.
SM	0.	0.	16.435	11666405.	0.
AV	0.	0.	0.090	64101.	0.

	FC-1	FC-1	FC-1	FC-1	FC-1
	TOT HTG COIL PWR BTU/HR	TOT CLG COIL PWR BTU/HR	SUPPLY ELECTRIC KW	COOLING CAPACITY BTU/HR	HEATING CAPACITY BTU/HR
	---- (5)	---- (6)	---- (49)	---- (70)	---- (78)
MONTHLY SUMMARY (AUG)					
MN	0.	0.	0.090	33651.	0.
MX	0.	0.	0.090	87587.	0.
SM	0.	0.	14.087	9804835.	0.
AV	0.	0.	0.090	62852.	0.
MONTHLY SUMMARY (SEP)					
MN	0.	0.	0.090	28795.	0.
MX	0.	0.	0.090	88494.	0.
SM	0.	0.	16.435	9325010.	0.
AV	0.	0.	0.090	51236.	0.
MONTHLY SUMMARY (OCT)					
MN	0.	0.	0.090	27317.	0.
MX	0.	2030.	0.090	49036.	0.
SM	0.	2030.	15.261	5478183.	0.
AV	0.	12.	0.090	32415.	0.
MONTHLY SUMMARY (NOV)					
MN	0.	0.	0.090	27154.	0.
MX	0.	5605.	0.090	41313.	0.
SM	0.	82676.	11.739	3664462.	0.
AV	0.	636.	0.090	28188.	0.
MONTHLY SUMMARY (DEC)					
MN	0.	0.	0.090	27414.	0.
MX	0.	1615.	0.090	36552.	0.
SM	0.	39493.	17.609	5787231.	0.
AV	0.	203.	0.090	29678.	0.
YEARLY SUMMARY					
MN	0.	0.	0.090	27154.	0.
MX	0.	10627.	0.090	96027.	0.
SM	0.	490979.	181.955	81344624.	0.
AV	0.	244.	0.090	40370.	0.

S I T E E N E R G Y													* SOURCE
MONTH	2	3	4	5	6	7	8	9	10	11	12	13	14
	TOTAL HEAT LOAD	TOTAL COOLING LOAD	TOTAL ELECTR LOAD	RCVRED ENERGY	WASTED RCVRABL ENERGY	FUEL INPUT COOLING	ELEC INPUT COOLING	FUEL INPUT HEATING	ELEC INPUT HEATING	FUEL INPUT ELECT	TOTAL FUEL INPUT	TOTAL SITE ENERGY	TOTAL SOURCE ENERGY
JAN	53.9	3.6	49.8 14.6E	0.0	0.0	0.0	8.4 2.5E	88.1	6.2 1.8E	0.0	88.1	137.9	237.7
FEB	46.0	3.9	46.0 13.5E	0.0	0.0	0.0	9.0 2.6E	75.2	5.4 1.6E	0.0	75.2	121.1	213.1
MAR	26.1	3.5	43.5 12.8E	0.0	0.0	0.0	8.2 2.4E	42.7	3.8 1.1E	0.0	42.7	86.3	173.5
APR	9.8	2.0	35.8 10.5E	0.0	0.0	0.0	4.5 1.3E	16.0	2.3 0.7E	0.0	16.0	51.8	123.6
MAY	3.7	37.7	96.0 28.1E	0.0	0.0	0.0	60.0 17.6E	6.1	1.8 0.5E	0.0	6.1	102.0	294.2
JUN	2.6	64.5	129.4 37.9E	0.0	0.0	0.0	98.3 28.8E	4.3	1.6 0.5E	0.0	4.3	133.7	392.9
JUL	2.7	83.1	158.1 46.3E	0.0	0.0	0.0	124.4 36.4E	4.5	1.7 0.5E	0.0	4.5	162.6	479.3
AUG	2.7	66.0	129.3 37.9E	0.0	0.0	0.0	99.0 29.0E	4.4	1.7 0.5E	0.0	4.4	133.7	392.7
SEP	2.7	57.0	118.2 34.6E	0.0	0.0	0.0	85.4 25.0E	4.5	1.6 0.5E	0.0	4.5	122.6	359.4
OCT	6.7	24.0	76.0 22.3E	0.0	0.0	0.0	41.3 12.1E	10.9	2.0 0.6E	0.0	10.9	87.0	239.2
NOV	21.2	2.6	37.1 10.9E	0.0	0.0	0.0	6.1 1.8E	34.7	3.3 1.0E	0.0	34.7	71.8	146.2
DEC	47.7	4.0	51.0 14.9E	0.0	0.0	0.0	9.4 2.7E	77.9	5.6 1.7E	0.0	77.9	128.9	231.1
=====	226.0	352.0	970.2 284.2E	0.0	0.0	0.0	553.9 162.2E	369.2	37.0 10.8E	0.0	369.2	1339.5	3282.8

NOTE-- ALL ENTRIES ARE IN METU EXCEPT
 ENTRIES FOLLOWED BY E ARE IN MWH (THOUSANDS OF KWH)

MO	UTILITY-	ELECTRICITY	NATURAL-GAS
	TOTAL (MBTU)	49.802	88.127
JAN	PEAK (KBTU)	171.069	787.908
	DY/HR	20/11	20/ 8
	TOTAL (MBTU)	45.950	75.158
FEB	PEAK (KBTU)	178.531	831.585
	DY/HR	3/11	3/ 8
	TOTAL (MBTU)	43.535	42.717
MAR	PEAK (KBTU)	162.643	637.573
	DY/HR	4/11	17/ 8
	TOTAL (MBTU)	35.840	15.979
APR	PEAK (KBTU)	157.839	467.343
	DY/HR	8/11	9/ 8
	TOTAL (MBTU)	95.954	6.083
MAY	PEAK (KBTU)	686.850	44.296
	DY/HR	21/17	10/ 7
	TOTAL (MBTU)	129.402	4.322
JUN	PEAK (KBTU)	727.092	17.090
	DY/HR	10/18	3/ 9
	TOTAL (MBTU)	158.126	4.462
JUL	PEAK (KBTU)	733.156	7.729
	DY/HR	9/17	2/ 9
	TOTAL (MBTU)	129.288	4.414
AUG	PEAK (KBTU)	741.541	7.655
	DY/HR	18/17	5/ 9
	TOTAL (MBTU)	118.184	4.465
SEP	PEAK (KBTU)	733.741	23.903
	DY/HR	1/17	30/ 9
	TOTAL (MBTU)	76.018	10.945
OCT	PEAK (KBTU)	662.716	407.156
	DY/HR	13/17	27/ 8
	TOTAL (MBTU)	37.121	34.684
NOV	PEAK (KBTU)	164.150	673.484
	DY/HR	25/11	25/ 8
	TOTAL (MBTU)	51.009	77.871
DEC	PEAK (KBTU)	171.042	775.668
	DY/HR	22/11	22/ 8
	ONE YEAR	970.230	369.228
	USE/PEAK	741.541	831.585

ENTECH ENGINEERING
 READING, PA 19603
 REPORT- PS-D PLANT LOADS SATISFIED

EZDOE - ELITE SOFTWARE DEVELOPMENT INC
 FT. GEORGE G. MEADE

DOE-2.1D 6/28/1996 10:59:23 PDL RUN 1
 EMCS STUDY WEATHER FILE- BALTIMORE, MD

```

-----
HEATING LOADS          MBTU SUPPLIED      PCT OF TOTAL LOAD
-----
HW-BOILER              226.0              100.0
=====
LOAD SATISFIED        226.0              100.0
TOTAL LOAD ON PLANT  226.0

COOLING LOADS          MBTU SUPPLIED      PCT OF TOTAL LOAD
-----
HERM-REC-CHLR         352.0              100.0
=====
LOAD SATISFIED        352.0              100.0
TOTAL LOAD ON PLANT  352.0

ELECTRICAL LOADS       MBTU SUPPLIED      PCT OF TOTAL LOAD
-----
ELECTRICITY           970.2              100.0
=====
LOAD SATISFIED        970.2              100.0
TOTAL LOAD ON PLANT  970.2
  
```

ENTECH ENGINEERING
READING, PA 19603
REPORT- PS-D PLANT LOADS SATISFIED

EZDOE - ELITE SOFTWARE DEVELOPMENT INC
FT. GEORGE G. MEADE

DOE-2.1D 6/28/1996 10:59:23 PDL RUN 1
EMCS STUDY

WEATHER FILE- BALTIMORE, MD

(CONTINUED)

SUMMARY OF LOADS MET

TYPE OF LOAD	TOTAL LOAD (MBTU)	LOAD SATISFIED (MBTU)	TOTAL OVERLOAD (MBTU)	PEAK OVERLOAD (MBTU)	HOURS OVERLOADED
HEATING LOADS	226.0	226.0	0.000	0.000	0
COOLING LOADS	352.0	352.0	0.000	0.000	0
ELECTRICAL LOADS	970.2	970.2	0.000	0.000	0

ENTECH ENGINEERING
READING, PA 19603
REPORT- PS-I EQUIPMENT LIFE CYCLE COSTS

EZDOE - ELITE SOFTWARE DEVELOPMENT INC
FT. GEORGE G. MEADE

DOE-2.1D 6/28/1996 10:59:23 PDL RUN 1
EMCS STUDY WEATHER FILE- BALTIMORE, MD

EQUIPMENT TOTALS

HW-BOILER	74.7		
NOMINAL SIZE (MBTU)		1.800	
NUMBER INSTALLED		1	
FIRST COST (K\$)	52.6	52.6	
ANNUAL COST (K\$)	1.0	1.0	
CYCLICAL COST (K\$)	21.2	21.2	
-----TOTAL----- (K\$)		74.7	
HERM-REC-CHLR	30.1		
NOMINAL SIZE (MBTU)		1.100	
NUMBER INSTALLED		1	
FIRST COST (K\$)	24.2	24.2	
ANNUAL COST (K\$)	2.3	2.3	
CYCLICAL COST (K\$)	3.6	3.6	
-----TOTAL----- (K\$)		30.1	
EQUIPMENT TOTAL	104.8		

ENERGY TYPE IN SITE MBTU -	ELECTRICITY	NATURAL-GAS
CATEGORY OF USE		
SPACE HEAT	19.87	369.24
SPACE COOL	533.20	0.00
HVAC AUX	179.94	0.00
DOM HOT WTR	0.00	0.00
AUX SOLAR	0.00	0.00
LIGHTS	230.36	0.00
VERT TRANS	0.00	0.00
MISC EQUIP	6.86	0.00
TOTAL	970.23	369.24

TOTAL SITE ENERGY 1339.46 MBTU 88.7 KBTU/SQFT-YR GROSS-AREA 88.7 KBTU/SQFT-YR NET-AREA
 TOTAL SOURCE ENERGY 3282.83 MBTU 217.4 KBTU/SQFT-YR GROSS-AREA 217.4 KBTU/SQFT-YR NET-AREA

PERCENT OF HOURS ANY SYSTEM ZONE OUTSIDE OF THROTTLING RANGE = 5.5
 PERCENT OF HOURS ANY PLANT LOAD NOT SATISFIED = 0.0

NOTE ELECTRICITY AND/OR FUEL USED TO GENERATE ELECTRICITY IS APPORTIONED BASED
 ON THE YEARLY DEMAND. ALL OTHER ENERGY TYPES ARE APPORTIONED HOURLY.

MMDDHH	HW-BOILE R LOAD BTU/HR	HW-BOILE R ELECTRIC USE BTU/HR	HW-BOILE R FUEL USE BTU/HR	HERM-REC -CHLR LOAD BTU/HR	HERM-REC -CHLR ELECTRIC USE BTU/HR	HERM-REC -CHLR NOM CAP RUNNING BTU/HR
	----(1)	----(3)	----(4)	----(1)	----(3)	----(7)
MONTHLY SUMMARY (JAN)						
MN	3513.	309.	5740.	0.	0.	0.
MX	494010.	39600.	787908.	22488.	40588.	1100000.
SM	53940460.	4742887.	88126872.	3605048.	6507912.	322300000.
AV	72501.	6375.	118450.	4845.	8747.	433199.
MONTHLY SUMMARY (FEB)						
MN	3513.	309.	5740.	0.	0.	0.
MX	530730.	39600.	831585.	27087.	48884.	1100000.
SM	46031572.	4038064.	75158328.	3880456.	7005018.	337700000.
AV	68499.	6009.	111843.	5774.	10424.	502530.
MONTHLY SUMMARY (MAR)						
MN	3513.	309.	5740.	0.	0.	0.
MX	390158.	34334.	637573.	18773.	33885.	1100000.
SM	26140122.	2300331.	42716616.	3533778.	6379779.	308000000.
AV	35135.	3092.	57415.	4750.	8575.	413979.
MONTHLY SUMMARY (APR)						
MN	3513.	309.	5740.	0.	0.	0.
MX	285987.	25167.	467343.	15891.	28686.	1100000.
SM	9778197.	860482.	15978943.	1952163.	3526841.	167200000.
AV	13581.	1195.	22193.	2711.	4898.	232222.
MONTHLY SUMMARY (MAY)						
MN	3513.	309.	5740.	0.	0.	0.
MX	27107.	2385.	44296.	475539.	561083.	1100000.
SM	3722417.	327573.	6082948.	37733160.	58773168.	196900000.
AV	5003.	440.	8176.	50717.	78996.	264651.
MONTHLY SUMMARY (JUN)						
MN	3513.	309.	5740.	0.	0.	0.
MX	10458.	920.	17090.	588902.	601324.	1100000.
SM	2644740.	232737.	4321874.	64543548.	96344208.	324500000.
AV	3673.	323.	6003.	89644.	133811.	450694.
MONTHLY SUMMARY (JUL)						
MN	3513.	309.	5740.	0.	0.	0.
MX	4730.	416.	7729.	576306.	607389.	1100000.
SM	2730637.	240296.	4462243.	83107304.	121893464.	419100000.
AV	3670.	323.	5998.	111703.	163835.	563306.

	HW-BOILE R LOAD BTU/HR	HW-BOILE R ELECTRIC USE BTU/HR	HW-BOILE R FUEL USE BTU/HR	HERM-REC -CHLR LOAD BTU/HR	HERM-REC -CHLR ELECTRIC USE BTU/HR	HERM-REC -CHLR NOM CAP RUNNING BTU/HR
	----(1)	----(3)	----(4)	----(1)	----(3)	----(7)
MONTHLY SUMMARY (AUG)						
MN	3513.	309.	5740.	0.	0.	0.
MK	4685.	412.	7655.	604562.	615773.	1100000.
SM	2701209.	237706.	4414153.	66003796.	96828688.	356400000.
AV	3631.	319.	5933.	88715.	130146.	479032.
MONTHLY SUMMARY (SEP)						
MN	3513.	309.	5740.	0.	0.	0.
MK	14627.	1287.	23903.	566119.	607973.	1100000.
SM	2732066.	240422.	4464578.	57039220.	83789032.	265100000.
AV	3795.	334.	6201.	79221.	116374.	368194.
MONTHLY SUMMARY (OCT)						
MN	3513.	309.	5740.	0.	0.	0.
MK	249156.	21926.	407156.	410328.	536948.	1100000.
SM	6697997.	589424.	10945463.	24017184.	40190648.	179300000.
AV	9003.	792.	14712.	32281.	54020.	240995.
MONTHLY SUMMARY (NOV)						
MN	3513.	309.	5740.	0.	0.	0.
MK	412134.	36268.	673484.	17467.	31528.	1100000.
SM	21224734.	1867777.	34684188.	2604957.	4702511.	229900000.
AV	29479.	2594.	48172.	3618.	6531.	319306.
MONTHLY SUMMARY (DEC)						
MN	3513.	309.	5740.	0.	0.	0.
MK	483742.	39600.	775668.	26782.	48334.	1100000.
SM	47666736.	4190149.	77871528.	4025017.	7265972.	352000000.
AV	64068.	5632.	104666.	5410.	9766.	473118.
YEARLY SUMMARY						
MN	3513.	309.	5740.	0.	0.	0.
MK	530730.	39600.	831585.	604562.	615773.	1100000.
SM	226010896.	19867848.	369227712.	352045632.	533207232.	3458400000.
AV	25800.	2268.	42149.	40188.	60868.	394795.

FT. MEADE, MARYLAND

Building: 6800

Square feet 12,800

Exterior Wall	
Components	R-Value
Outside Surface	0.17
Vinyl Siding	0.61
1/2" Insulation	4.00
3/4" Plywood	0.93
3 1/2" Insulation	11.00
1/2" Drywall	0.56
Inside Surface	0.68
Total R-Value	17.95
Total U-Value	0.06

Exterior Roof	
Components	R-Value
Outside Surface	0.17
Asphalt Shingles	0.44
3/4" plywood	0.93
6" Batt Insulation	19.00
Air Space	1.10
Acoustic Tile Clg	1.89
Inside Surface	0.61
Total R-Value	24.14
Total U-Value	0.04

Calculated Total Area	
No. of Floors	1
Avg. Floor to Floor Height	10
No. of Basement Levels	
Gross Floor Area	12800
Roof Area	15000
Estimated Infiltration (cfm)	600
Gross Wall Area	5270
Door Area	
Gross Window Area	1365
Other	
Net Wall Area	3905

Window and Door	
	U-Value
Window Single Pane W/Storm	
Window Single Pane Wo/Storm	
Window Double Pane	0.55
Skylight	
Glass Block	
Other	
Door Type 1	
Door Type 2	
Door Type 3	

$$UoAo = (3905 \cdot 0.06) + (15000 \cdot 0.04) + (1365 \cdot 0.55) = 1585$$

FT. MEADE, MARYLAND EQUIPMENT SCHEDULE

BUILDING NO. 6800

Page 1 of 1

EQUIPMENT	SYSTEM NUMBER							
	1	2	3	4	5	6	7	8
Equipment Name	RTU-A	RTU-B	RTU-C	RTU-D	RTU-E			
COOLING:								
Type of Cooling	1	1	1	1	1			
Air Side	3	3	3	3	3			
Location in Building	Bar	Dining	Pro Shop	Dining	Kitchen			
Area Sq. Feet	2128	2689	2142	2730	1505			
Supply CFM	4000	6000	3000	6000	3000			
Supply Fan HP	2	3	2	3	2			
O.A. CFM or %	20%	20%	20%	20%	40%			
Return CFM								
Return Fan HP								
Chiller Tonnage	10	15	7 1/2	15	7 1/2			
Tower or Condenser Fan HP	1	1.5	3	1.5	1			
Condenser Pump HP								
Chilled Water Pump HP								
HEATING:								
Type of Heating								
Source	1	1	1	1	1			
MBTUH	204/161.5	204/161.5	163.3/129.4	204/161.5	163.3/129.4			
Hot Water Pump HP								
Condensate Pump HP								
ADDITIONAL:								
Aux. HP Cooling								
Aux. HP Heating								
Operating Schedule Hrs./Week								
Type of Cooling					Type of Heating			
(1) Air Cooled DX	(4) Water Cooled Chiller				(1) Boiler Hot Water			
(2) Water Cooled DX	(5) Central Plant Supplied				(2) Boiler Steam			
(3) Air Cooled Chiller	(6) Other				(3) Steam to Hot Water Converter			
	Air Side				Heating Source			
(1) Single Zone	(4) VAV w/ Reheat				(1) Natural Gas			
(2) Multi-Zone	(5) Constant Volume Reheat				(2) Central Plant Steam			
(3) VAV	(6) Heating and Ventilating				(3) Central Plant Hot Water			
					(4) Oil			
					(5) Electric			

EMCS Annual Energy Savings Summary Report

```

=====
Base: FTMEADE
Building: 6800
Case: 1
Description:
-----

```

```

-----
Fuel Type: Natural gas (methane)
Heating Value: 1,031 Btu/cf
=====

```

Caution

```

=====
The ESA program makes no attempt to exclude incompatible strategies.
It is the user's responsibility to select all appropriate strategies.
=====

```

Annual Energy Savings Table for Single Zone DX-A/C

```

=====
Description: RTU-C
=====

```

Strategy	MBtu/yr	kWh/yr	kW	mh/yr
Demand Limiting	0.000	0	0.7	0
Day/Night Setback	16.211	53	0.0	0
Vent/Recirculation	4.444	0	0.0	0
Run Time Recording	0.000	0	0.0	2
Safety Alarm	0.000	0	0.0	2

Subtotals	20.655	53	0.7	4
Heating Value /	1,031 Btu/cf			
=====				
Totals	20,034	53	0.7	4
	cf /yr	kWh/yr	kW	mh/yr
=====				

Annual Energy Savings Table for Single Zone DX-A/C

Description: RTU-E				
Strategy	MBtu/yr	kWh/yr	kW	mh/yr
Demand Limiting	0.000	0	0.4	0
Day/Night Setback	11.390	37	0.0	0
Vent/Recirculation	6.666	0	0.0	0
Run Time Recording	0.000	0	0.0	2
Safety Alarm	0.000	0	0.0	2
Subtotals	18.056	37	0.4	4
Heating Value /	1,031 Btu/cf			
Totals	17,513 cf /yr	37 kWh/yr	0.4 kW	4 mh/yr

Annual Energy Savings Table for Single Zone DX-A/C

Description: RTU-B				
Strategy	MBtu/yr	kWh/yr	kW	mh/yr
Demand Limiting	0.000	0	0.7	0
Day/Night Setback	20.350	66	0.0	0
Vent/Recirculation	13.332	0	0.0	0
Run Time Recording	0.000	0	0.0	2
Safety Alarm	0.000	0	0.0	2
Subtotals	33.682	66	0.7	4
Heating Value /	1,031 Btu/cf			
Totals	32,670 cf /yr	66 kWh/yr	0.7 kW	4 mh/yr

Annual Energy Savings Table for Single Zone DX-A/C

Description: RTU-D

Strategy	MBtu/yr	kWh/yr	kW	mh/yr
Demand Limiting	0.000	0	0.7	0
Day/Night Setback	20.661	67	0.0	0
Vent/Recirculation	22.220	0	0.0	0
Run Time Recording	0.000	0	0.0	2
Safety Alarm	0.000	0	0.0	2
Subtotals	42.881	67	0.7	4
Heating Value /	1,031 Btu/cf			
Totals	41,591 cf /yr	67 kWh/yr	0.7 kW	4 mh/yr

Annual Energy Savings Table for Single Zone DX-A/C

Description: RTU-A

Strategy	MBtu/yr	kWh/yr	kW	mh/yr
Demand Limiting	0.000	0	0.4	0
Day/Night Setback	16.105	52	0.0	0
Vent/Recirculation	14.813	0	0.0	0
Run Time Recording	0.000	0	0.0	2
Safety Alarm	0.000	0	0.0	2
Subtotals	30.918	52	0.4	4
Heating Value /	1,031 Btu/cf			
Totals	29,988 cf /yr	52 kWh/yr	0.4 kW	4 mh/yr

EMCS Annual Energy Savings for Building 6800

Description	Value	Units
Natural gas (methane)	141,796	cf /yr
Electrical Energy	275	kWh/yr
Electrical Demand Reduction	3.0	kW
Labor Savings	20	mh/yr

FT. MEADE, MARYLAND

Building: 7100

Square feet 30,503

Exterior Wall	
Components	R-Value
Outside Surface	0.17
Brick	0.44
Concrete Block	1.72
Air Space	1.10
1/2" Drywall	0.56
Inside Surface	0.68
Total R-Value	4.67
Total U-Value	0.21

Exterior Roof	
Components	R-Value
Outside Surface	0.17
Shingles	0.44
1" Wood Deck	0.93
Inside Surface	0.61
Total R-Value	2.15
Total U-Value	0.47

Calculated Total Area	
No. of Floors	1
Avg. Floor to Floor Height	15
No. of Basement Levels	
Gross Floor Area	30500
Roof Area	30500
Estimated Infiltration (cfm)	3100
Gross Wall Area	26199
Door Area	294
Gross Window Area	3254
Other	
Net Wall Area	22651

Window and Door	
	U-Value
Window Single Pane W/Storm	0.60
Window Single Pane Wo/Storm	
Window Double Pane	
Skylight	
Glass Block	
Other	
Door Type 1	1.00
Door Type 2	
Door Type 3	

$$UoAo = (22651 \times 0.21) + (30500 \times 0.47) + (3254 \times 0.6) + (294 \times 1.0) = 21338$$

**FT. MEADE, MARYLAND
EQUIPMENT SCHEDULE**

BUILDING NO. 7100

Page 1 of 1

EQUIPMENT	SYSTEM NUMBER							
	1	2	3	4	5	6	7	8
Equipment Name	Chiller	Boiler	Fan Colls					
COOLING:								
Type of Cooling								
Air Side								
Location in Building			All					
Area Sq. Feet			30500					
Supply CFM			25					
Supply Fan HP								
O.A. CFM or %								
Return CFM								
Return Fan HP								
Chiller Tonnage	120							
Tower or Condenser Fan HP								
Condenser Pump HP								
Chilled Water Pump HP	10							
HEATING:								
Type of Heating		1						
Source		1						
MBTUH		2025/1620						
Hot Water Pump HP								
Condensate Pump HP								
ADDITIONAL:								
Aux. HP Cooling								
Aux. HP Heating								
Operating Schedule Hrs./Week								
Type of Cooling							Type of Heating	
(1) Air Cooled DX	(4) Water Cooled Chiller			(1) Boiler Hot Water			(4) Furnace	
(2) Water Cooled DX	(5) Central Plant Supplied			(2) Boiler Steam			(5) Electric	
(3) Air Cooled Chiller	(6) Other			(3) Steam to Hot Water Converter			(6) Heating Source	
	Air Side							
(1) Single Zone	(4) VAV w/ Reheat						(1) Natural Gas	
(2) Multi-Zone	(5) Constant Volume Reheat						(2) Central Plant Steam	
(3) VAV	(6) Heating and Ventilating						(3) Central Plant Hot Water	

EMCS Annual Energy Savings Summary Report

```

=====
Base: FTMEADE
Building: 7100
Case: 1
Description:
=====

```

```

=====
Fuel Type: Natural gas (methane)
Heating Value: 1,031 Btu/cf
=====

```

Caution

```

=====
The ESA program makes no attempt to exclude incompatible strategies.
It is the user's responsibility to select all appropriate strategies.
=====

```

Annual Energy Savings Table for Two Pipe Fan Coil Unit

```

=====
Description: UNIT VENTILATORS
=====

```

Strategy	MBtu/yr	kWh/yr	kW	mh/yr
Day/Night Setback	604.437	2,993	0.0	0
Run Time Recording	0.000	0	0.0	2
Safety Alarm	0.000	0	0.0	2

Subtotals	604.437	2,993	0.0	4
Heating Value /	1,031 Btu/cf			
=====				
Totals	586,263	2,993	0.0	4
	cf /yr	kWh/yr	kW	mh/yr

```

=====

```

Annual Energy Savings Table for Hot Water Boiler

Description: BOILER				
Strategy	MBtu/yr	kWh/yr	kW	mh/yr
Hot Water OA Reset	151.875	0	0.0	0
Run Time Recording	0.000	0	0.0	2
Safety Alarm	0.000	0	0.0	2
Subtotals	151.875	0	0.0	4
Heating Value /	1,031 Btu/cf			
Totals	147,308 cf /yr	0 kWh/yr	0.0 kW	4 mh/yr

Annual Energy Savings Table for Air Cooled Chiller

Description: CHILLER				
Strategy	MBtu/yr	kWh/yr	kW	mh/yr
Scheduled Start/Stop	0.000	21,340	0.0	0
Chiller Water Reset	0.000	5,011	0.0	0
Run Time Recording	0.000	0	0.0	2
Safety Alarm	0.000	0	0.0	2
Totals	0.000 MBtu/yr	26,351 kWh/yr	0.0 kW	4 mh/yr

EMCS Annual Energy Savings for Building 7100

Description	Value	Units
Natural gas (methane)	733,571	cf /yr
Electrical Energy	29,344	kWh/yr
Electrical Demand Reduction	0.0	kW
Labor Savings	12	mh/yr

ATTACHMENT SECTION 8.2G

BUILDINGS 8452 TO 9829

EMCS Annual Energy Savings Summary Report

```

=====
Base: FTMEADE
Building: 8452
Case: 1
Description: REC CENTER
-----
Fuel Type: Natural gas (methane)
Heating Value: 1,031 Btu/cf
=====
    
```

Caution

```

=====
The ESA program makes no attempt to exclude incompatible strategies.
It is the user's responsibility to select all appropriate strategies.
=====
    
```

Annual Energy Savings Table for Single Zone DX-A/C

```

=====
Description: AHU-1
=====
Strategy                MBtu/yr      kWh/yr      kW   mh/yr
=====
Demand Limiting         0.000         0           0.4   0
Day/Night Setback      60.718        395         0.0   0
Vent/Recirculation      9.047         0           0.0   0
Run Time Recording      0.000         0           0.0   2
Safety Alarm            0.000         0           0.0   2
-----
Subtotals                69.764        395         0.4   4
Heating Value /         1,031 Btu/cf
=====
Totals                  67,667        395         0.4   4
                        cf/yr        kWh/yr      kW   mh/yr
=====
    
```

Annual Energy Savings Table for Single Zone DX-A/C

Description: AHU-2				
Strategy	MBtu/yr	kWh/yr	kW	mh/yr
Demand Limiting	0.000	0	0.4	0
Day/Night Setback	60.718	395	0.0	0
Vent/Recirculation	9.047	0	0.0	0
Run Time Recording	0.000	0	0.0	2
Safety Alarm	0.000	0	0.0	2
Subtotals	69.764	395	0.4	4
Heating Value /	1,031 Btu/cf			
Totals	67,667 cf/yr	395 kWh/yr	0.4 kW	4 mh/yr

Annual Energy Savings Table for Single Zone DX-A/C

Description: AHU-3				
Strategy	MBtu/yr	kWh/yr	kW	mh/yr
Demand Limiting	0.000	0	0.7	0
Day/Night Setback	118.851	772	0.0	0
Vent/Recirculation	11.993	0	0.0	0
Run Time Recording	0.000	0	0.0	2
Safety Alarm	0.000	0	0.0	2
Subtotals	130.844	772	0.7	4
Heating Value /	1,031 Btu/cf			
Totals	126,910 cf/yr	772 kWh/yr	0.7 kW	4 mh/yr

Annual Energy Savings Table for Single Zone DX-A/C

Description: AHU-4				
Strategy	MBtu/yr	kWh/yr	kW	mh/yr
Demand Limiting	0.000	0	0.7	0
Day/Night Setback	80.095	521	0.0	0
Vent/Recirculation	91.260	0	0.0	0
Run Time Recording	0.000	0	0.0	2
Safety Alarm	0.000	0	0.0	2
Subtotals	171.356	521	0.7	4
Heating Value /	1,031 Btu/cf			
Totals	166,204 cf/yr	521 kWh/yr	0.7 kW	4 mh/yr

Annual Energy Savings Table for Steam/Hot Water Converter

Description: CONVERTER				
Strategy	MBtu/yr	kWh/yr	kW	mh/yr
Day/Night Setback	709.180	0	0.0	0
Hot Water OA Reset	171.429	0	0.0	0
Run Time Recording	0.000	0	0.0	2
Safety Alarm	0.000	0	0.0	2
Subtotals	880.609	0	0.0	4
Heating Value /	1,031 Btu/cf			
Totals	854,131 cf/yr	0 kWh/yr	0.0 kW	4 mh/yr

Annual Energy Savings Table for Lighting Control

Description: LIGHTING				
Strategy	MBtu/yr	kWh/yr	kW	mh/yr
Lighting Control	0.000	57,200	0.0	0
Totals	0.000	57,200	0.0	0
	MBtu/yr	kWh/yr	kW	mh/yr

EMCS Annual Energy Savings for Building 8452

Description	Value	Units
Natural gas (methane)	1,282,578	cf/yr
Electrical Energy	59,282	kWh/yr
Electrical Demand Reduction	2.4	kW
Labor Savings	20	mh/yr

FT. MEADE, MARYLAND

Building: 8465

Square feet 9,567

Exterior Wall	
Components	R-Value
Outside Surface	0.17
Concrete Block	1.72
Inside Surface	0.68
Total R-Value	2.57
Total U-Value	0.39

Exterior Roof	
Components	R-Value
Outside Surface	0.17
Built-up Roof	0.33
1" Insulation	6.00
Wood Deck	0.93
Air Space	1.10
Gyp Board	0.56
Inside Surface	0.61
Total R-Value	9.70
Total U-Value	0.10

Calculated Total Area	
No. of Floors	1
Avg. Floor to Floor Height	15.5
No. of Basement Levels	
Gross Floor Area	9567
Roof Area	9567
Estimated Infiltration (cfm)	1150
Gross Wall Area	7834
Door Area	168
Gross Window Area	1116
Other	
Net Wall Area	6550

Window and Door	
	U-Value
Window Single Pane W/Storm	0.60
Window Single Pane Wo/Storm	
Window Double Pane	
Skylight	
Glass Block	
Other	
Door Type 1	1.00
Door Type 2	
Door Type 3	

$$UoAo = (6550 \cdot 0.39) + (9567 \cdot 0.10) + (168 \cdot 1.0) + (1116 \cdot 0.6) = 4350$$

**FT. MEADE, MARYLAND
EQUIPMENT SCHEDULE**

BUILDING NO. 8465

Page 1 of 1

EQUIPMENT	SYSTEM NUMBER							
	1	2	3	4	5	6	7	8
Equipment Name	AHU-1	Unit Vents	Chiller	S-W Conv				
COOLING:								
Type of Cooling	4	4	4					
Air Side	1	1						
Location in Building	Chapel	Classrms & Off						
Area Sq. Feet	4545	4000						
Supply CFM	5000							
Supply Fan HP	3	2						
O.A. CFM or %	100%							
Return CFM								
Return Fan HP								
Chiller Tonnage			50					
Tower or Condenser Fan HP								
Condenser Pump HP			2					
Chilled Water Pump HP			2					
HEATING:								
Type of Heating				3				
Source				2				
MBTUH				700				
Hot Water Pump HP								
Condensate Pump HP				1/3				
ADDITIONAL:								
Aux. HP Cooling								
Aux. HP Heating								
Operating Schedule Hrs./Week								
Type of Cooling	Type of Heating							
(1) Air Cooled DX	(4) Water Cooled Chiller			(1) Boiler Hot Water				
(2) Water Cooled DX	(5) Central Plant Supplied			(2) Boiler Steam				
(3) Air Cooled Chiller	(6) Other			(3) Steam to Hot Water Converter				
	Air Side			Heating Source				
(1) Single Zone	(4) VAV w/ Reheat			(1) Natural Gas				
(2) Multi-Zone	(5) Constant Volume Reheat			(2) Central Plant Steam				
(3) VAV	(6) Heating and Ventilating			(3) Central Plant Hot Water				
				(4) Furnace				
				(4) Oil				
				(5) Electric				

EMCS Annual Energy Savings Summary Report

```

=====
Base: FTMEADE
Building: 8465
Case: 1
Description:
=====

```

```

=====
Fuel Type: Natural gas (methane)
Heating Value: 1,031 Btu/cf
=====

```

Caution

```

=====
The ESA program makes no attempt to exclude incompatible strategies.
It is the user's responsibility to select all appropriate strategies.
=====

```

Annual Energy Savings Table for Single Zone AHU

```

=====
Description: AHU
=====

```

Strategy	MBtu/yr	kWh/yr	kW	mh/yr
Duty Cycling	0.000	1,397	0.0	0
Demand Limiting	0.000	0	0.4	0
Day/Night Setback	73.273	295	0.0	0
Vent/Recirculation	42.731	0	0.0	0
Run Time Recording	0.000	0	0.0	2
Safety Alarm	0.000	0	0.0	2

Subtotals	116.004	1,691	0.4	4
Heating Value /	1,031 Btu/cf			
=====				
Totals	112,516 cf/yr	1,691 kWh/yr	0.4 kW	4 mh/yr

Annual Energy Savings Table for Steam/Hot Water Converter

Description: CONVERTER				
Strategy	MBtu/yr	kWh/yr	kW	mh/yr
Day/Night Setback	154.236	0	0.0	0
Hot Water OA Reset	64.615	0	0.0	0
Run Time Recording	0.000	0	0.0	2
Safety Alarm	0.000	0	0.0	2
Subtotals	218.851	0	0.0	4
Heating Value /	1,031 Btu/cf			
Totals	212,271 cf/yr	0 kWh/yr	0.0 kW	4 mh/yr

Annual Energy Savings Table for Water Cooled Chiller

Description: CHILLER				
Strategy	MBtu/yr	kWh/yr	kW	mh/yr
Chiller Water Reset	0.000	2,088	0.0	0
Condenser Water Reset	0.000	4,797	0.0	0
Run Time Recording	0.000	0	0.0	2
Safety Alarm	0.000	0	0.0	2
Totals	0.000 MBtu/yr	6,885 kWh/yr	0.0 kW	4 mh/yr

EMCS Annual Energy Savings for Building 8465

Description	Value	Units
Natural gas (methane)	324,787	cf/yr
Electrical Energy	8,576	kWh/yr
Electrical Demand Reduction	0.4	kW
Labor Savings	12	mh/yr

FT. MEADE, MARYLAND

Building: 8472

Square feet 10,000

Exterior Wall	
Components	R-Value
Outside Surface	0.17
Concrete Block 4"	0.86
Air Space	1.10
Concrete Block 6"	1.72
Inside Surface	0.68
Total R-Value	4.53
Total U-Value	0.22

Exterior Roof	
Components	R-Value
Outside Surface	0.17
Built-up Roof	0.33
Wood Deck	0.93
Air Space	1.10
3 1/2" Batt Insulation	11.00
Plaster Clg	0.56
Inside Surface	0.61
Total R-Value	14.70
Total U-Value	0.07

Calculated Total Area	
No. of Floors	1
Avg. Floor to Floor Height	10
No. of Basement Levels	
Gross Floor Area	10000
Roof Area	10000
Estimated Infiltration (cfm)	800
Gross Wall Area	4540
Door Area	84
Gross Window Area	602
Other	
Net Wall Area	3854

Window and Door	
	U-Value
Window Single Pane W/Storm	
Window Single Pane Wo/Storm	
Window Double Pane	0.55
Skylight	
Glass Block	
Other	
Door Type 1	1.00
Door Type 2	
Door Type 3	

$$UoAo = (3854 \times 0.22) + (10000 \times 0.07) + (84 \times 1.0) + (602 \times 0.55) = 1964$$

EMCS Annual Energy Savings Summary Report

```

=====
Base: FTMEADE
Building: 8472
Case: 1
Description:
=====

```

```

=====
Fuel Type: Natural gas (methane)
Heating Value: 1,031 Btu/cf
=====

```

Caution

```

=====
The ESA program makes no attempt to exclude incompatible strategies.
It is the user's responsibility to select all appropriate strategies.
=====

```

Annual Energy Savings Table for Multi-zone AHU

```

=====
Description: AHU-2
=====

```

Strategy	MBtu/yr	kWh/yr	kW	mh/yr
Day/Night Setback	70.201	282	0.0	0
Vent/Recirculation	102.553	0	0.0	0
Hot/Cold Deck Reset	112.214	4,439	0.0	0
Run Time Recording	0.000	0	0.0	2
Safety Alarm	0.000	0	0.0	2
Subtotals	284.968	4,721	0.0	4
Heating Value /	1,031 Btu/cf			
Totals	276,399 cf/yr	4,721 kWh/yr	0.0 kW	4 mh/yr

```

=====

```

Annual Energy Savings Table for Steam/Hot Water Converter

Description: CONVERTER				
Strategy	MBtu/yr	kWh/yr	kW	mh/yr
Day/Night Setback	78.001	0	0.0	0
Hot Water OA Reset	18.462	0	0.0	0
Subtotals	96.462	0	0.0	0
Heating Value /	1,031 Btu/cf			
Totals	93,562 cf/yr	0 kWh/yr	0.0 kW	0 mh/yr

Annual Energy Savings Table for Air Cooled Chiller

Description: CHILLER				
Strategy	MBtu/yr	kWh/yr	kW	mh/yr
Scheduled Start/Stop	0.000	3,140	0.0	0
Chiller Water Reset	0.000	3,257	0.0	0
Run Time Recording	0.000	0	0.0	2
Safety Alarm	0.000	0	0.0	2
Totals	0.000 MBtu/yr	6,397 kWh/yr	0.0 kW	4 mh/yr

EMCS Annual Energy Savings for Building 8472

Description	Value	Units
Natural gas (methane)	369,961	cf/yr
Electrical Energy	11,118	kWh/yr
Electrical Demand Reduction	0.0	kW
Labor Savings	8	mh/yr

FT. MEADE, MARYLAND

Building: 8476

Square feet 3,344

Exterior Wall	
Components	R-Value
Outside Surface	0.17
Concrete Block 4"	1.11
Air Space	1.10
Concrete Block 4"	1.11
Inside Surface	0.68
Total R-Value	4.17
Total U-Value	0.24

Exterior Roof	
Components	R-Value
Outside Surface	0.17
Built-up Roof	0.33
2" Poured Gyp Deck	5.88
1" Insulation	6.00
Air Space	1.10
Acoustic Tile Clg	1.89
Inside Surface	0.61
Total R-Value	15.98
Total U-Value	0.06

Calculated Total Area	
No. of Floors	1
Avg. Floor to Floor Height	12
No. of Basement Levels	
Gross Floor Area	3344
Roof Area	3344
Estimated Infiltration (cfm)	400
Gross Wall Area	3024
Door Area	42
Gross Window Area	75
Other	
Net Wall Area	2907

Window and Door	
	U-Value
Window Single Pane W/Storm	
Window Single Pane Wo/Storm	
Window Double Pane	0.55
Skylight	
Glass Block	
Other	
Door Type 1	1.00
Door Type 2	
Door Type 3	

$$UoAo = (2907*0.24) + (3344*0.06) + (75*0.55) + (42*1.0) = 982$$

EMCS Annual Energy Savings Summary Report

```

=====
Base: FTMEADE
Building: 8476
Case: 1
Description:
=====

```

```

=====
Fuel Type: Natural gas (methane)
Heating Value: 1,031 Btu/cf
=====

```

Caution

```

=====
The ESA program makes no attempt to exclude incompatible strategies.
It is the user's responsibility to select all appropriate strategies.
=====

```

Annual Energy Savings Table for Single Zone AHU

```

=====
Description: AHU
=====

```

Strategy	MBtu/yr	kWh/yr	kW	mh/yr
Day/Night Setback	39.000	235	0.0	0
Vent/Recirculation	6.837	0	0.0	0
Run Time Recording	0.000	0	0.0	2
Safety Alarm	0.000	0	0.0	2
Subtotals	45.837	235	0.0	4
Heating Value /	1,031 Btu/cf			
Totals	44,459 cf /yr	235 kWh/yr	0.0 kW	4 mh/yr

```

=====

```

Annual Energy Savings Table for Air Cooled DX Compressor

Description: CONDENSING UNIT				
Strategy	MBtu/yr	kWh/yr	kW	mh/yr
Scheduled Start/Stop	0.000	1,177	0.0	0
Run Time Recording	0.000	0	0.0	2
Safety Alarm	0.000	0	0.0	2
Totals	0.000	1,177	0.0	4
	MBtu/yr	kWh/yr	kW	mh/yr

Annual Energy Savings Table for Lighting Control

Description: LIGHTING				
Strategy	MBtu/yr	kWh/yr	kW	mh/yr
Lighting Control	0.000	17,472	0.0	0
Totals	0.000	17,472	0.0	0
	MBtu/yr	kWh/yr	kW	mh/yr

EMCS Annual Energy Savings for Building 8476

Description	Value	Units
Natural gas (methane)	44,459	cf /yr
Electrical Energy	18,885	kWh/yr
Electrical Demand Reduction	0.0	kW
Labor Savings	8	mh/yr

FT. MEADE, MARYLAND

Building: 8477

Square feet 3,504

Exterior Wall	
Components	R-Value
Outside Surface	0.17
Concrete Block 4"	1.11
Air Space	1.10
Concrete Block 4"	1.11
Inside Surface	0.68
Total R-Value	4.17
Total U-Value	0.24

Exterior Roof	
Components	R-Value
Outside Surface	0.17
Built-up Roof	0.33
2" Poured Gyp Deck	5.88
1" Insulation	6.00
Air Space	1.10
Acoustic Tile Clg	1.89
Inside Surface	0.61
Total R-Value	15.98
Total U-Value	0.06

Calculated Total Area	
No. of Floors	1
Avg. Floor to Floor Height	12
No. of Basement Levels	
Gross Floor Area	3504
Roof Area	3504
Estimated Infiltration (cfm)	400
Gross Wall Area	3170
Door Area	42
Gross Window Area	75
Other	
Net Wall Area	3053

Window and Door	
	U-Value
Window Single Pane W/Storm	
Window Single Pane Wo/Storm	
Window Double Pane	0.55
Skylight	
Glass Block	
Other	
Door Type 1	1.00
Door Type 2	
Door Type 3	

$$UoAo = (3053 \times 0.24) + (3504 \times 0.06) + (75 \times 0.55) + (42 \times 1.0) = 1026$$

EMCS Annual Energy Savings Summary Report

```

=====
Base: FTMEADE
Building: 8478
Case: 1
Description:
=====

```

```

-----
Fuel Type: Natural gas (methane)
Heating Value: 1,031 Btu/cf
=====

```

Caution

```

=====
The ESA program makes no attempt to exclude incompatible strategies.
It is the user's responsibility to select all appropriate strategies.
=====

```

Annual Energy Savings Table for Single Zone DX-A/C

```

=====
Description: ROOFTOP
=====

```

Strategy	MBtu/yr	kWh/yr	kW	mh/yr
Day/Night Setback	43.510	228	0.0	0
Vent/Recirculation	0.000	0	0.0	0
Run Time Recording	0.000	0	0.0	2
Safety Alarm	0.000	0	0.0	2
Subtotals	43.510	228	0.0	4
Heating Value /	1,031 Btu/cf			
Totals	42,202 cf /yr	228 kWh/yr	0.0 kW	4 mh/yr

```

=====

```

Annual Energy Savings Table for Steam/Hot Water Converter

Description: CONVERTOR

Strategy	MBtu/yr	kWh/yr	kW	mh/yr
Hot Water OA Reset	443.077	0	0.0	0
Run Time Recording	0.000	0	0.0	2
Safety Alarm	0.000	0	0.0	2
Subtotals	443.077	0	0.0	4
Heating Value /	1,031 Btu/cf			
Totals	429,755 cf /yr	0 kWh/yr	0.0 kW	4 mh/yr

Annual Energy Savings Table for Air Cooled Chiller

Description: CHILLER

Strategy	MBtu/yr	kWh/yr	kW	mh/yr
Scheduled Start/Stop	0.000	0	0.0	0
Chiller Water Reset	0.000	2,714	0.0	0
Run Time Recording	0.000	0	0.0	0
Safety Alarm	0.000	0	0.0	0
Totals	0.000 MBtu/yr	2,714 kWh/yr	0.0 kW	0 mh/yr

EMCS Annual Energy Savings for Building 8478

Description	Value	Units
Natural gas (methane)	471,956	cf /yr
Electrical Energy	2,942	kWh/yr
Electrical Demand Reduction	0.0	kW
Labor Savings	8	mh/yr

EMCS Annual Energy Savings Summary Report

```

=====
Base: FTMEADE
Building: 8481
Case: 1
Description: STEAM BOILER PLANT
=====

```

```

=====
Fuel Type: Natural gas (methane)
Heating Value: 1,031 Btu/cf
=====

```

Caution

```

=====
The ESA program makes no attempt to exclude incompatible strategies.
It is the user's responsibility to select all appropriate strategies.
=====

```

Annual Energy Savings Table for Steam Boiler

```

=====
Description: STEAM BOILER PLANT
=====

```

Strategy	MBtu/yr	kWh/yr	kW	mh/yr
Steam Boiler Selection	729.947	0	0.0	0
Run Time Recording	0.000	0	0.0	2
Safety Alarm	0.000	0	0.0	2
Subtotals	729.947	0	0.0	4
Heating Value /	1,031 Btu/cf			
Totals	707,999 cf /yr	0 kWh/yr	0.0 kW	4 mh/yr

EMCS Annual Energy Savings for Building 8481

```

=====
Description                Value                Units
=====
Natural gas (methane)      707,999             cf /yr
Electrical Energy          0                   kWh/yr
Electrical Demand Reduction 0.0                 kW
Labor Savings              4                   mh/yr
=====

```

FT. MEADE, MARYLAND

Building: 8485, 8486

Square feet 4,864

Exterior Wall	
Components	R-Value
Outside Surface	0.17
Concrete Block	1.72
Inside Surface	0.68
Total R-Value	2.57
Total U-Value	0.39

Exterior Roof	
Components	R-Value
Outside Surface	0.17
Shingles	0.44
Wood deck	0.93
Insulation	6.00
Inside Surface	0.61
Total R-Value	8.15
Total U-Value	0.12

Calculated Total Area	
No. of Floors	1
Avg. Floor to Floor Height	18
No. of Basement Levels	
Gross Floor Area	4864
Roof Area	5760
Estimated Infiltration (cfm)	1500
Gross Wall Area	5156
Door Area	1152
Gross Window Area	252
Other	
Net Wall Area	3752

Window and Door	
	U-Value
Window Single Pane W/Storm	0.60
Window Single Pane Wo/Storm	
Window Double Pane	
Skylight	
Glass Block	
Other	
Door Type 1	1.00
Door Type 2	
Door Type 3	

$UoAo = (3752 \cdot 0.39) + (5760 \cdot 0.12) + (1152 \cdot 1.0) + (252 \cdot 0.6) = 3457.7$

**FT. MEADE, MARYLAND
EQUIPMENT SCHEDULE**

BUILDING NO. 8485, 8486

EQUIPMENT	SYSTEM NUMBER							
	1	2	3	4	5	6	7	8
Equipment Name	Furnace							
COOLING:								
Type of Cooling								
Air Side								
Location in Building								
Area Sq. Feet								
Supply CFM	4500							
Supply Fan HP	2							
O.A. CFM or %								
Return CFM								
Return Fan HP								
Chiller Tonnage								
Tower or Condenser Fan HP								
Condenser Pump HP								
Chilled Water Pump HP								
HEATING:								
Type of Heating	4							
Source	4							
MBTUH	500/400							
Burner HP	1/3							
Condensate Pump HP								
ADDITIONAL:								
Aux. HP Cooling								
Aux. HP Heating								
Operating Schedule Hrs./Week								
Type of Cooling								
(1) Air Cooled DX								
(2) Water Cooled DX								
(3) Air Cooled Chiller								
Air Side								
(4) VAV w/ Reheat								
(5) Constant Volume Reheat								
(6) Heating and Ventilating								
Type of Heating								
(1) Boiler Hot Water								(4) Furnace
(2) Boiler Steam								(5) Electric
(3) Steam to Hot Water Converter								
Heating Source								
(1) Natural Gas								(4) Oil
(2) Central Plant Steam								(5) Electric
(3) Central Plant Hot Water								

EMCS Annual Energy Savings Summary Report

```

=====
Base: FTMEADE
Building: 8485
Case: 1
Description:
=====

```

```

=====
Fuel Type: Fuel oil, distillate #2
Heating Value: 138,700 Btu/gal
=====

```

Caution

```

=====
The ESA program makes no attempt to exclude incompatible strategies.
It is the user's responsibility to select all appropriate strategies.
=====

```

Annual Energy Savings Table for Direct Fired Furnace

```

=====
Description: FURNACE
=====

```

Strategy	MBtu/yr	kWh/yr	kW	mh/yr
Day/Night Setback	113.791	0	0.0	0
Run Time Recording	0.000	0	0.0	2
Safety Alarm	0.000	0	0.0	2
Subtotals	113.791	0	0.0	4
Heating Value /	138,700 Btu/gal			
Totals	820 gal/yr	0 kWh/yr	0.0 kW	4 mh/yr

EMCS Annual Energy Savings for Building 8485

Description	Value	Units
Fuel oil, distillate #2	820	gal/yr
Electrical Energy	0	kWh/yr
Electrical Demand Reduction	0.0	kW
Labor Savings	4	mh/yr

FT. MEADE, MARYLAND

Building: 8606

Square feet 38,490

Exterior Wall	
Components	R-Value
Outside Surface	0.17
Concrete Block	1.89
Inside Surface	0.68
Total R-Value	2.74
Total U-Value	0.36

Exterior Roof	
Components	R-Value
Outside Surface	0.17
Built-up Roof	0.33
1 1/2" Insulation	9.00
Concrete Deck	0.44
Air Space	1.10
Plaster clg	0.56
Inside Surface	0.61
Total R-Value	12.21
Total U-Value	0.08

Calculated Total Area	
No. of Floors	3
Avg. Floor to Floor Height	10.5
No. of Basement Levels	
Gross Floor Area	38490
Roof Area	13380
Estimated Infiltration (cfm)	3850
Gross Wall Area	19978
Door Area	126
Gross Window Area	2144
Other	
Net Wall Area	17708

Window and Door	
	U-Value
Window Single Pane W/Storm	
Window Single Pane Wo/Storm	
Window Double Pane	0.55
Skylight	
Glass Block	
Other	
Door Type 1	0.60
Door Type 2	
Door Type 3	

$$U_oA_o = (17708 \times 0.36) + (13380 \times 0.08) + (126 \times 0.6) + (2144 \times 0.55) = 8700$$



EMCS Annual Energy Savings Summary Report

```

=====
Base: FTMEADE
Building: 8606
Case: 1
Description:
=====

```

```

=====
Fuel Type: Natural gas (methane)
Heating Value: 1,031 Btu/cf
=====

```

Caution

```

=====
The ESA program makes no attempt to exclude incompatible strategies.
It is the user's responsibility to select all appropriate strategies.
=====

```

Annual Energy Savings Table for Single Zone DX-A/C

```

=====
Description: ROOFTOP
=====

```

Strategy	MBtu/yr	kWh/yr	kW	mh/yr
Day/Night Setback	43.510	228	0.0	0
Vent/Recirculation	0.000	0	0.0	0
Run Time Recording	0.000	0	0.0	2
Safety Alarm	0.000	0	0.0	2
Subtotals	43.510	228	0.0	4
Heating Value /	1,031 Btu/cf			
Totals	42,202 cf /yr	228 kWh/yr	0.0 kW	4 mh/yr

```

=====

```

Annual Energy Savings Table for Steam/Hot Water Converter

Description: CONVERTOR

Strategy	MBtu/yr	kWh/yr	kW	mh/yr
Hot Water OA Reset	443.077	0	0.0	0
Run Time Recording	0.000	0	0.0	2
Safety Alarm	0.000	0	0.0	2
Subtotals	443.077	0	0.0	4
Heating Value /	1,031 Btu/cf			
Totals	429,755 cf /yr	0 kWh/yr	0.0 kW	4 mh/yr

Annual Energy Savings Table for Air Cooled Chiller

Description: CHILLER

Strategy	MBtu/yr	kWh/yr	kW	mh/yr
Chiller Water Reset	0.000	2,714	0.0	0
Run Time Recording	0.000	0	0.0	0
Safety Alarm	0.000	0	0.0	0
Totals	0.000 MBtu/yr	2,714 kWh/yr	0.0 kW	0 mh/yr

EMCS Annual Energy Savings for Building 8606

Description	Value	Units
Natural gas (methane)	471,956	cf /yr
Electrical Energy	2,942	kWh/yr
Electrical Demand Reduction	0.0	kW
Labor Savings	8	mh/yr

FT. MEADE, MARYLAND

Building: 9801, 9802, 9803, 9804

Square feet 80,550

Exterior Wall	
Components	R-Value
Outside Surface	0.17
Brick	0.44
Air Space	1.10
Concrete Block	1.72
Inside Surface	0.68
Total R-Value	4.11
Total U-Value	0.24

Exterior Roof	
Components	R-Value
Outside Surface	0.17
Built-up Roof	0.33
1" Insulation	6.00
Metal Deck	0.00
Air Space	1.10
Acoustical Tile Clg	1.89
Inside Surface	0.61
Total R-Value	10.10
Total U-Value	0.10

Calculated Total Area	
No. of Floors	3
Avg. Floor to Floor Height	10.5
No. of Basement Levels	1
Gross Floor Area	80550
Roof Area	28410
Estimated Infiltration (cfm)	7100
Gross Wall Area	45754
Door Area	294
Gross Window Area	3100
Other	
Net Wall Area	42360

Window and Door	
	U-Value
Window Single Pane W/Storm	
Window Single Pane Wo/Storm	
Window Double Pane	0.55
Skylight	
Glass Block	
Other	
Door Type 1	1.00
Door Type 2	
Door Type 3	

$$U_oA_o = (42360 \times 0.24) + (28410 \times 0.10) + (294 \times 1.0) + (3100 \times 0.55) = 15006$$



EMCS Annual Energy Savings Summary Report

```

=====
Base: FTMEADE
Building: 9810
Case: 1
Description:
=====

```

```

=====
Fuel Type: Natural gas (methane)
Heating Value: 1,031 Btu/cf
=====

```

Caution

```

=====
The ESA program makes no attempt to exclude incompatible strategies.
It is the user's responsibility to select all appropriate strategies.
=====

```

Annual Energy Savings Table for Single Zone AHU

```

=====
Description: AHU-1
=====

```

Strategy	MBtu/yr	kWh/yr	kW	mh/yr
Demand Limiting	0.000	0	0.4	0
Day/Night Setback	51.651	145	0.0	0
Economizer	0.000	0	0.0	0
Vent/Recirculation	6.349	0	0.0	0
Run Time Recording	0.000	0	0.0	2
Safety Alarm	0.000	0	0.0	2

Subtotals	58.000	145	0.4	4
Heating Value /	1,031 Btu/cf			
=====				
Totals	56,256 cf/yr	145 kWh/yr	0.4 kW	4 mh/yr

Annual Energy Savings Table for Single Zone AHU

Description: AHU-2				
Strategy	MBtu/yr	kWh/yr	kW	mh/yr
Demand Limiting	0.000	0	0.4	0
Day/Night Setback	51.651	145	0.0	0
Economizer	0.000	0	0.0	0
Vent/Recirculation	6.349	0	0.0	0
Run Time Recording	0.000	0	0.0	2
Safety Alarm	0.000	0	0.0	2
Subtotals	58.000	145	0.4	4
Heating Value /	1,031 Btu/cf			
Totals	56,256 cf/yr	145 kWh/yr	0.4 kW	4 mh/yr

Annual Energy Savings Table for Single Zone AHU

Description: AHU-3				
Strategy	MBtu/yr	kWh/yr	kW	mh/yr
Scheduled Start/Stop	256.406	9,498	0.0	0
Optimum Start/Stop	0.000	0	0.0	0
Demand Limiting	0.000	0	0.7	0
Economizer	0.000	0	0.0	0
Vent/Recirculation	15.713	0	0.0	0
Run Time Recording	0.000	0	0.0	2
Safety Alarm	0.000	0	0.0	2
Subtotals	272.118	9,498	0.7	4
Heating Value /	1,031 Btu/cf			
Totals	263,936 cf/yr	9,498 kWh/yr	0.7 kW	4 mh/yr

Annual Energy Savings Table for Single Zone AHU

Description: AHU-4				
Strategy	MBtu/yr	kWh/yr	kW	mh/yr
Scheduled Start/Stop	145.655	4,128	0.0	0
Optimum Start/Stop	0.000	0	0.0	0
Demand Limiting	0.000	0	0.3	0
Economizer	0.000	0	0.0	0
Vent/Recirculation	8.888	0	0.0	0
Run Time Recording	0.000	0	0.0	2
Safety Alarm	0.000	0	0.0	2
Subtotals	154.543	4,128	0.3	4
Heating Value /	1,031 Btu/cf			
Totals	149,896 cf/yr	4,128 kWh/yr	0.3 kW	4 mh/yr

Annual Energy Savings Table for Heating/Ventilating Unit

Description: H&V UNIT				
Strategy	MBtu/yr	kWh/yr	kW	mh/yr
Scheduled Start/Stop	356.488	2,944	0.0	0
Optimum Start/Stop	0.000	0	0.0	0
Vent/Recirculation	31.743	0	0.0	0
Run Time Recording	0.000	0	0.0	2
Safety Alarm	0.000	0	0.0	2
Subtotals	388.231	2,944	0.0	4
Heating Value /	1,031 Btu/cf			
Totals	376,558 cf/yr	2,944 kWh/yr	0.0 kW	4 mh/yr

Annual Energy Savings Table for Hot Water Radiation

```

=====
Description: FIN TUBE
=====
Strategy                MBtu/yr          kWh/yr          kW   mh/yr
=====
    Day/Night Setback    92.326           0               0.0   0
-----
        Subtotals        92.326           0               0.0   0
    Heating Value /      1,031 Btu/cf
=====
        Totals          89,550           0               0.0   0
                        cf/yr          kWh/yr          kW   mh/yr
=====
    
```

Annual Energy Savings Table for Steam/Hot Water Converter

```

=====
Description: CONVERTER
=====
Strategy                MBtu/yr          kWh/yr          kW   mh/yr
=====
    Day/Night Setback    516.542          0               0.0   0
    Hot Water OA Reset    18.462           0               0.0   0
    Run Time Recording     0.000           0               0.0   2
    Safety Alarm           0.000           0               0.0   2
-----
        Subtotals        535.003          0               0.0   4
    Heating Value /      1,031 Btu/cf
=====
        Totals          518,917          0               0.0   4
                        cf/yr          kWh/yr          kW   mh/yr
=====
    
```

Annual Energy Savings Table for Air Cooled Chiller

Description: CHILLER				
Strategy	MBtu/yr	kWh/yr	kW	mh/yr
Scheduled Start/Stop	0.000	7,849	0.0	0
Optimum Start/Stop	0.000	0	0.0	0
Chiller Water Reset	0.000	3,800	0.0	0
Run Time Recording	0.000	0	0.0	2
Safety Alarm	0.000	0	0.0	2
Totals	0.000	11,649	0.0	4
	MBtu/yr	kWh/yr	kW	mh/yr

EMCS Annual Energy Savings for Building 9810

Description	Value	Units
Natural gas (methane)	1,511,369	cf/yr
Electrical Energy	28,510	kWh/yr
Electrical Demand Reduction	1.9	kW
Labor Savings	28	mh/yr

FT. MEADE, MARYLAND

Building: 9827

Square feet 68,061

Exterior Wall	
Components	R-Value
Outside Surface	0.17
Brick	0.44
Concrete Block	1.72
Inside Surface	0.68
Total R-Value	3.01
Total U-Value	0.33

Exterior Roof	
Components	R-Value
Outside Surface	0.17
Built-up Roof	0.33
Metal Deck	0.00
Air Space	1.10
1" Insulation	6.00
Acoustical Tile	1.89
Inside Surface	0.61
Total R-Value	10.10
Total U-Value	0.10

Calculated Total Area	
No. of Floors	3
Avg. Floor to Floor Height	11
No. of Basement Levels	1
Gross Floor Area	68061
Roof Area	21120
Estimated Infiltration (cfm)	6120
Gross Wall Area	34408
Door Area	170
Gross Window Area	3888
Other	
Net Wall Area	30350

Window and Door	
	U-Value
Window Single Pane W/Storm	0.60
Window Single Pane Wo/Storm	
Window Double Pane	
Skylight	
Glass Block	
Other	
Door Type 1	0.50
Door Type 2	
Door Type 3	

$$AoU_o = (30350 \times 0.33) + (21120 \times 0.1) + (3888 \times 0.6) + (170 \times 0.5) = 14545.3$$

EMCS Annual Energy Savings Summary Report

```

=====
Base: FTMEADE
Building: 9827
Case: 1
Description:
=====

```

```

=====
Fuel Type: Natural gas (methane)
Heating Value: 1,031 Btu/cf
=====

```

Caution

```

=====
The ESA program makes no attempt to exclude incompatible strategies.
It is the user's responsibility to select all appropriate strategies.
=====

```

Annual Energy Savings Table for Hot Water Boiler

```

=====
Description: HOT WATER BOILER
=====

```

Strategy	MBtu/yr	kWh/yr	kW	mh/yr
Hot Water OA Reset	375.000	0	0.0	0
Run Time Recording	0.000	0	0.0	2
Safety Alarm	0.000	0	0.0	2
Subtotals	375.000	0	0.0	4
Heating Value /	1,031 Btu/cf			
Totals	363,725 cf/yr	0 kWh/yr	0.0 kW	4 mh/yr

Annual Energy Savings Table for Air Cooled Chiller

```

=====
Description: AIR COOLED CHILLER
=====

```

Strategy	MBtu/yr	kWh/yr	kW	mh/yr
Chiller Water Reset	0.000	4,176	0.0	0
Run Time Recording	0.000	0	0.0	2
Safety Alarm	0.000	0	0.0	2
Totals	0.000 MBtu/yr	4,176 kWh/yr	0.0 kW	4 mh/yr

EMCS Annual Energy Savings for Building 9827

Description	Value	Units
Natural gas (methane)	363,725	cf/yr
Electrical Energy	4,176	kWh/yr
Electrical Demand Reduction	0.0	kW
Labor Savings	8	mh/yr

FT. MEADE, MARYLAND

Building: 9828

Square feet 128,393

Exterior Wall	
Components	R-Value
Outside Surface	0.17
Brick	0.44
Concrete Block	1.72
Inside Surface	0.68
Total R-Value	3.01
Total U-Value	0.33

Exterior Roof	
Components	R-Value
Outside Surface	0.17
Built-up Roof	0.33
Metal Deck	0.00
Air Space	1.10
1" Insulation	6.00
Acoustical Tile	1.89
Inside Surface	0.61
Total R-Value	10.10
Total U-Value	0.10

Calculated Total Area	
No. of Floors	3
Avg. Floor to Floor Height	10
No. of Basement Levels	
Gross Floor Area	128393
Roof Area	43795
Estimated Infiltration (cfm)	11600
Gross Wall Area	50876
Door Area	420
Gross Window Area	5534
Other	
Net Wall Area	44922

Window and Door	
	U-Value
Window Single Pane W/Storm	
Window Single Pane Wo/Storm	1.00
Window Double Pane	
Skylight	
Glass Block	
Other	
Door Type 1	1.00
Door Type 2	
Door Type 3	

$$AoUo = (44922 \times 0.33) + (43975 \times 0.1) + (5534 \times 1.0) + (420 \times 1.0) = 25158$$

EMCS Annual Energy Savings Summary Report

```

=====
Base: FTMEADE
Building: 9828
Case: 1
Description: UEPH
-----
Fuel Type: Natural gas (methane)
Heating Value: 1,031 Btu/cf
=====
    
```

Caution

```

=====
The ESA program makes no attempt to exclude incompatible strategies.
It is the user's responsibility to select all appropriate strategies.
=====
    
```

Annual Energy Savings Table for Single Zone AHU

```

=====
Description: AHU-1
=====
Strategy                MBtu/yr      kWh/yr      kW   mh/yr
=====
Scheduled Start/Stop    230.703      7,225       0.0   0
Vent/Recirculation      21.387        0           0.0   0
Run Time Recording       0.000         0           0.0   2
Safety Alarm             0.000         0           0.0   2
-----
Subtotals                252.090      7,225       0.0   4
Heating Value /         1,031 Btu/cf
=====
Totals                  244,510      7,225       0.0   4
                        cf/yr      kWh/yr      kW   mh/yr
=====
    
```

Annual Energy Savings Table for Hot Water Boiler

Description: HOT WATER BOILER				
Strategy	MBtu/yr	kWh/yr	kW	mh/yr
Hot Water OA Reset	376.560	0	0.0	0
Run Time Recording	0.000	0	0.0	2
Safety Alarm	0.000	0	0.0	2
Subtotals	376.560	0	0.0	4
Heating Value /	1,031 Btu/cf			
Totals	365,238 cf/yr	0 kWh/yr	0.0 kW	4 mh/yr

Annual Energy Savings Table for Water Cooled Chiller

Description: WATER COOLED RECIP CHILLER				
Strategy	MBtu/yr	kWh/yr	kW	mh/yr
Chiller Water Reset	0.000	7,517	0.0	0
Condenser Water Reset	0.000	17,270	0.0	0
Run Time Recording	0.000	0	0.0	2
Safety Alarm	0.000	0	0.0	2
Totals	0.000 MBtu/yr	24,787 kWh/yr	0.0 kW	4 mh/yr

EMCS Annual Energy Savings for Building 9828

Description	Value	Units
Natural gas (methane)	609,748	cf/yr
Electrical Energy	32,012	kWh/yr
Electrical Demand Reduction	0.0	kW
Labor Savings	12	mh/yr

FT. MEADE, MARYLAND

Building: 9829

Square feet 16,905

Exterior Wall	
Components	R-Value
Outside Surface	0.17
Brick	0.44
Air Space	1.10
Concrete Block	1.72
Gyp Board	0.56
Inside Surface	0.68
Total R-Value	4.67
Total U-Value	0.21

Exterior Roof	
Components	R-Value
Outside Surface	0.17
Built-up Roof	0.33
1 1/2" Insulation	9.00
Metal Deck	0.00
Air Space	1.10
Acoustical Tile Clg	1.89
Inside Surface	0.61
Total R-Value	13.10
Total U-Value	0.08

Calculated Total Area	
No. of Floors	1
Avg. Floor to Floor Height	12
No. of Basement Levels	
Gross Floor Area	16905
Roof Area	16905
Estimated Infiltration (cfm)	1500
Gross Wall Area	5950
Door Area	168
Gross Window Area	504
Other	
Net Wall Area	5278

Window and Door	
	U-Value
Window Single Pane W/Storm	
Window Single Pane Wo/Storm	
Window Double Pane	0.55
Skylight	
Glass Block	
Other	
Door Type 1	1.00
Door Type 2	
Door Type 3	

$$U_oA_o = (5278 \times 0.21) + (16905 \times 0.08) + (504 \times 0.55) + (168 \times 1.0) = 2906$$



EMCS Annual Energy Savings Summary Report

```

=====
Base: FTMEADE
Building: 9829
Case: 1
Description:
=====

```

```

-----
Fuel Type: Natural gas (methane)
Heating Value: 1,031 Btu/cf
=====

```

Caution

```

=====
The ESA program makes no attempt to exclude incompatible strategies.
It is the user's responsibility to select all appropriate strategies.
=====

```

Annual Energy Savings Table for Multi-zone DX-A/C

```

=====
Description: AHU-1
=====

```

Strategy	MBtu/yr	kWh/yr	kW	mh/yr
Day/Night Setback	39.110	272	0.0	0
Economizer	0.000	0	0.0	0
Vent/Recirculation	14.813	0	0.0	0
Hot/Cold Deck Reset	108.058	7,398	0.0	0
Run Time Recording	0.000	0	0.0	2
Safety Alarm	0.000	0	0.0	2
Subtotals	161.981	7,670	0.0	4
Heating Value /	1,031 Btu/cf			
Totals	157,111 cf /yr	7,670 kWh/yr	0.0 kW	4 mh/yr

```

=====

```

Annual Energy Savings Table for Multi-zone DX-A/C

Description: AHU-2				
Strategy	MBtu/yr	kWh/yr	kW	mh/yr
Day/Night Setback	39.110	272	0.0	0
Economizer	0.000	0	0.0	0
Vent/Recirculation	14.813	0	0.0	0
Hot/Cold Deck Reset	108.058	7,398	0.0	0
Run Time Recording	0.000	0	0.0	2
Safety Alarm	0.000	0	0.0	2
Subtotals	161.981	7,670	0.0	4
Heating Value /	1,031 Btu/cf			
Totals	157,111 cf /yr	7,670 kWh/yr	0.0 kW	4 mh/yr

Annual Energy Savings Table for Heating/Ventilating Unit

Description: MU-2				
Strategy	MBtu/yr	kWh/yr	kW	mh/yr
Scheduled Start/Stop	1,165.195	9,814	0.0	0
Optimum Start/Stop	0.000	0	0.0	0
Vent/Recirculation	118.364	0	0.0	0
Run Time Recording	0.000	0	0.0	2
Safety Alarm	0.000	0	0.0	2
Subtotals	1,283.559	9,814	0.0	4
Heating Value /	1,031 Btu/cf			
Totals	1,244,965 cf /yr	9,814 kWh/yr	0.0 kW	4 mh/yr

Annual Energy Savings Table for Heating/Ventilating Unit

Description: MU-1				
Strategy	MBtu/yr	kWh/yr	kW	mh/yr
Day/Night Setback	0.000	0	0.0	0
Vent/Recirculation	25.638	0	0.0	0
Run Time Recording	0.000	0	0.0	2
Safety Alarm	0.000	0	0.0	2
Subtotals	25.638	0	0.0	4
Heating Value /	1,031 Btu/cf			
Totals	24,867 cf /yr	0 kWh/yr	0.0 kW	4 mh/yr

EMCS Annual Energy Savings for Building 9829

Description	Value	Units
Natural gas (methane)	1,584,053	cf /yr
Electrical Energy	25,155	kWh/yr
Electrical Demand Reduction	0.0	kW
Labor Savings	16	mh/yr

ATTACHMENT SECTION 8.3

UMCS COST ESTIMATE

ALL BUILDINGS

SYSTEM COSTS AND INPUT SHEET

for Smart Field Panels & Remote Terminal Units

Site: PORT GEORGE G. MEADE
 Date: JULY 1996
 Name: Craig Snyder - Estech Eng'g
 Phone: 610-373-6667

Inputs	
Labor Cost \$ per Hour	\$27.50
Overhead & Profit Percentage	20.00%
Contractors Bond	1.25%
Excavation Percentage	3.50%
Contingency Percentage	10.00%
SIOH	
	5.5%

System No.	Description	DOC				Total System Cost	Supervisory				
		270000 Material Cost \$	Labor Hrs	220000 Cost per Hour	230000 Cost per System		System Material Cost	Labor Hrs	220000 Cost per Hour	230000 Cost per System	
1	Steam HW Converter (Fig 8-1 & 9-1)	\$4,321.00	33	\$27.00	\$900	\$6,340	\$6,340.00	35	\$27.00	\$945	\$6,347
2	Hot Water Boiler (Fig 8-2 & 9-2)	\$14,968.00	86	\$27.00	\$1,848	\$16,808	\$14,968.00	86	\$27.00	\$1,848	\$16,808
3	Hot Water Boiler w/CV Loop (Fig 8-3 & 9-3)	\$18,484.00	64	\$27.00	\$1,760	\$17,214	\$18,484.00	64	\$27.00	\$1,760	\$17,214
4	High Temp. HW/HW Converter (Fig 8-4 & 9-4)	\$4,892.00	30	\$27.00	\$810	\$5,417	\$4,664.00	32	\$27.00	\$864	\$5,834
5	Secondary Pumping (Fig 8-1, 2, 3, 4 & 9-1, 2, 3, 4)	\$700.00	11	\$27.00	\$303	\$1,011	\$700.00	11	\$27.00	\$303	\$1,011
6	Steam HW Converter Dual Temp (Fig 8-5 & 9-5)	\$6,177.00	51	\$27.00	\$1,383	\$7,590	\$6,239.00	53	\$27.00	\$1,461	\$7,697
7	High Temp. HW/HW Converter Dual Temp (Fig 8-6 & 9-6)	\$6,417.00	48	\$27.00	\$1,310	\$6,727	\$6,499.00	50	\$27.00	\$1,378	\$6,874
8	Dual Temp Sys w/CV HW Loop Boiler and Air Cooled Chiller (Fig 8-7 & 9-7)	\$18,082.00	100	\$27.00	\$2,700	\$21,772	\$18,082.00	100	\$27.00	\$2,700	\$21,772
9	Dual Temp Sys Boiler and Air Cooled Chiller (Fig 8-8 & 9-8)	\$19,513.00	100	\$27.00	\$2,700	\$21,643	\$16,548.00	82	\$27.00	\$2,256	\$19,282
10	Water Cooled Chiller (Fig 8-9 & 9-9)	\$13,894.00	101	\$27.00	\$2,727	\$16,673	\$14,843.00	103	\$27.00	\$2,833	\$14,976
11	Multi Zone AH W/ HW and CHW Coils (Fig 8-10 & 9-10)	\$3,381.00	46	\$27.00	\$1,246	\$4,616	\$3,287.00	43	\$27.00	\$1,181	\$3,499
12	Dual Duct AH W/ HW and CHW Coils (Fig 8-11 & 9-11)	\$3,381.00	46	\$27.00	\$1,246	\$4,616	\$3,289.00	40	\$27.00	\$1,078	\$4,664
13	BYPASS UNIT ZONE AH W/ HW and CHW Coils (Fig 8-12 & 9-12)	\$3,139.00	43	\$27.00	\$1,183	\$4,322	\$3,877.00	47	\$27.00	\$1,293	\$4,370
14	VAV AH W/ HW and CHW Coils (Fig 8-13 & 9-13)	\$3,798.00	57	\$27.00	\$1,540	\$5,338	\$3,633.00	40	\$27.00	\$1,078	\$3,963
15	VAV AH W/ HW and CHW Coils and Ret. Fan (Fig 8-14 & 9-14)	\$3,836.00	102	\$27.00	\$2,806	\$15,841	\$3,877.00	82	\$27.00	\$1,434	\$4,307
16	Single Zone AH W/ HW and CHW Coils (Fig 8-15 & 9-15)	\$3,798.00	42	\$27.00	\$1,156	\$3,953	\$3,144.00	34	\$27.00	\$918	\$3,134
17	Single Zone AH W/ HW and CHW Coils & Humidification (Fig 8-16 & 9-16)	\$3,930.00	46	\$27.00	\$1,246	\$4,195	\$3,827.00	47	\$27.00	\$1,293	\$3,920
18	Single Zone AH W/ HW and D Coils (Fig 8-17 & 9-17)	\$3,446.00	49	\$27.00	\$1,340	\$4,794	\$3,222.00	33	\$27.00	\$1,000	\$4,000
19	Heating and Ventilating (Fig 8-18 & 9-18)	\$1,644.00	21	\$27.00	\$567	\$2,097	\$1,733.00	22	\$27.00	\$600	\$2,613
20	VAV Box DDC Control/ or Space Temp.	\$759.00	7	\$27.00	\$193	\$952	\$142.00	3	\$27.00	\$81	\$207
21	Steam Boiler (Fig 9-19)	\$46,317.00	117	\$27.00	\$3,159	\$49,476	\$46,317.00	117	\$27.00	\$3,159	\$49,476
22	Hot Water Boiler (Fig 9-20)	\$41,263.00	81	\$27.00	\$2,200	\$43,581	\$41,263.00	81	\$27.00	\$2,200	\$43,581
23	Electric Dom.HW System (Fig 9-21)	\$763.00	13	\$27.00	\$359	\$1,121	\$763.00	13	\$27.00	\$359	\$1,121
24	Oil/Gas Dom.HW System (Fig 9-22)	\$5,162.00	43	\$27.00	\$1,183	\$6,345	\$5,162.00	43	\$27.00	\$1,183	\$6,345
25	Steam Dom.HW System (Fig 9-23)	\$791.00	11	\$27.00	\$303	\$1,094	\$791.00	11	\$27.00	\$303	\$1,094
26	Steam Unit Heater (Fig 9-24)	\$281.00	8	\$27.00	\$216	\$497	\$281.00	8	\$27.00	\$216	\$497
27	Hot Water Unit Heater (Fig 9-25)	\$281.00	8	\$27.00	\$216	\$497	\$281.00	8	\$27.00	\$216	\$497
28	Electric Unit Heater (Fig 9-26)	\$283.00	6	\$27.00	\$166	\$449	\$283.00	6	\$27.00	\$166	\$449
29	Electric Radiation (Fig 9-27)	\$283.00	6	\$27.00	\$166	\$449	\$283.00	6	\$27.00	\$166	\$449
30	Lighting Control (9-28)	\$834.00	21	\$27.00	\$578	\$1,411	\$834.00	21	\$27.00	\$578	\$1,411
31	Lighting Override Switches	\$78.00	8,25	\$27.00	\$225	\$303	\$78.00	8,25	\$27.00	\$225	\$303
32	Water Storage and Distribution System (Fig 9-30)	\$6,298.00	13	\$27.00	\$359	\$7,254	\$6,298.00	13	\$27.00	\$359	\$7,254
33	Storage Lift System (Fig 9-31)	\$208.00	16	\$27.00	\$440	\$1,318	\$208.00	16	\$27.00	\$440	\$1,318
34	Second Pumps (Duplex)	\$708.00	11	\$27.00	\$303	\$1,011	\$708.00	11	\$27.00	\$303	\$1,011
35	Additional Pumps (CIW and HW)	\$708.00	11	\$27.00	\$303	\$1,011	\$708.00	11	\$27.00	\$303	\$1,011
36	Air Cooled DX Compressor	\$567.00	8	\$27.00	\$216	\$783	\$436.00	8	\$27.00	\$216	\$652
37	Gas/Oil Fired Furnace	\$678.00	13	\$27.00	\$359	\$1,037	\$678.00	13	\$27.00	\$359	\$1,037
38	Single Zone DX Coil	\$3,081.00	47	\$27.00	\$1,283	\$4,374	\$3,081.00	34	\$27.00	\$918	\$3,643
39	Single Zone DX Coil w/Gas Heat	\$3,081.00	47	\$27.00	\$1,283	\$4,374	\$3,081.00	34	\$27.00	\$918	\$3,643
40	Roof Top Package Unit	\$678.00	13	\$27.00	\$359	\$1,037	\$678.00	13	\$27.00	\$359	\$1,037
41	Roof Top Package Unit w/ Gas Heat	\$678.00	13	\$27.00	\$359	\$1,037	\$678.00	13	\$27.00	\$359	\$1,037
42	Multi-Zone AH w/ HW and DX Coils	\$3,179.00	45	\$27.00	\$1,215	\$4,417	\$3,179.00	11	\$27.00	\$303	\$1,479
43	Building Electric Meter	\$1,974.00	21	\$27.00	\$578	\$2,552	\$1,974.00	11	\$27.00	\$297	\$2,552
44	Building Natural Gas Meter	\$609.00	3	\$27.00	\$81	\$690	\$609.00	3	\$27.00	\$81	\$690
45	DISTRIBUTION SYSTEM W/Temperature & Humidity Sensors	\$582.00	7	\$27.00	\$193	\$775	\$582.00	7	\$27.00	\$193	\$775
46	Outdoor Temperature Sensor w/Sunshield	\$113.00	2	\$27.00	\$56	\$267	\$113.00	2	\$27.00	\$56	\$267
47	Air Cooled Chiller	\$6,234.00	82	\$27.00	\$2,214	\$8,448	\$6,773.00	83	\$27.00	\$2,281	\$8,831
48	Smart Field Panel	\$2,600.00	16	\$27.00	\$440	\$3,040	\$2,600.00	16	\$27.00	\$440	\$3,040
49	Remote Terminal Unit	\$2,100.00	8	\$27.00	\$220	\$2,320	\$2,100.00	8	\$27.00	\$220	\$2,320

Item No.	Description	SYSTEM COST BY BUILDING for Smart Field Panels & Remote Terminal Units								SYSTEM COST BY BUILDING for Smart Field Panels & Remote Terminal Units								SYSTEM COST BY BUILDING for Smart Field Panels & Remote Terminal Units								SYSTEM COST BY BUILDING for Smart Field Panels & Remote Terminal Units							
		427		428		429		430		431		432		433		434		435		436		437		438		439		440					
		System	Cost	System	Cost	System	Cost	System	Cost	System	Cost	System	Cost	System	Cost	System	Cost	System	Cost	System	Cost	System	Cost	System	Cost	System	Cost	System	Cost				
1	Steam HW Converter (Fig 9-1 & 9-1)																																
2	Hot Water Boiler (Fig 9-2 & 9-2)	\$6,800				\$1,110							\$1,110		\$13,210							\$6,800				\$1,110		\$13,210					
3	Hot Water Boiler w/CV Loop (Fig 9-3 & 9-3)																																
4	High Temp. HW/HW Converter (Fig 9-4 & 9-4)																																
5	Secondary Pumping (Fig. 9-1, 2, 3, 4 & 9-1, 2, 3, 4)																																
6	Steam HW Converter Dual Temp (Fig 9-4 & 9-5)																																
7	High Temp. HW/HW Converter Dual Temp (Fig 9-4 & 9-4)																																
8	Loop Boiler and Air Cooled Chiller (Fig 9-5 & 9-5)																																
9	Dual Temp. HW Boiler and Air Cooled Chiller (Fig 9-5 & 9-5)																																
10	Water Cooled Chiller (Fig 9-9 & 9-9)																																
11	Multi Zone AH W/ HW and CW Coil (Fig 9-10 & 9-10)						\$1,810		\$11,800																								
12	Dual Zone AH W/ HW and CW Coil (Fig 9-11 & 9-11)																																
13	Single Zone AH W/ HW and CW Coil (Fig 9-12 & 9-12)																																
14	VAV AH W/ HW and CW Coil (Fig 9-13 & 9-13)																																
15	VAV AH W/ HW and CW Coil and Rec. Fan (Fig 9-14 & 9-14)																																
16	Single Zone AH W/ HW and CW Coil (Fig 9-15 & 9-15)						\$1,360																										
17	Single Zone AH W/ HW and CW Coil & Humidification (Fig 9-16 & 9-16)																																
18	Single Zone AH W/ HW and DX Coil (Fig 9-17 & 9-17)	\$1,420						\$1,420		\$1,420		\$1,420		\$1,420		\$1,420		\$1,420		\$1,420		\$1,420		\$1,420		\$1,420		\$1,420					
19	Heating and Ventilating (Fig 9-18 & 9-18)						\$1,497																			\$1,497		\$1,497					
20	VAV Box DDC Control or Reset Temp.																																
21	Room Boiler (Fig 9-19)																																
22	Hot Water Boiler (Fig 9-20)																																
23	Electric Dual HW System (Fig 9-21)																																
24	Oil Gas Dual HW System (Fig 9-22)																																
25	Steam Dual HW System (Fig 9-23)																																
26	Steam Unit Heater (Fig 9-24)																																
27	Hot Water Unit Heater (Fig 9-25)																																
28	Electric Unit Heater (Fig 9-26)																																
29	Electric Radiator (Fig 9-27)																																
30	Lighting Control (9-28)	\$1,213				\$1,213		\$1,213		\$1,213		\$1,213		\$1,213		\$1,213		\$1,213		\$1,213		\$1,213		\$1,213		\$1,213		\$1,213					
31	Lighting Override Buttons	\$1,213				\$1,213		\$1,213		\$1,213		\$1,213		\$1,213		\$1,213		\$1,213		\$1,213		\$1,213		\$1,213		\$1,213		\$1,213					
32	Water Storage and Distribution System (Fig 9-29)																																
33	Storage Lift System (Fig 9-31)																																
34	Roof Top Package (Fig 9-32)																																
35	Additional Pump (CHW and HW)	\$1,213																										\$1,213					
36	Air Cooled DX Compressor																																
37	Gas/Oil Fired Furnace																																
38	Single Zone DX Coil							\$1,213																									
39	Single Zone DX Coil w/ Gas Heat																																
40	Roof Top Package Unit																																
41	Roof Top Package Unit w/ Gas Heat	\$700																															
42	Multi-Zone AH w/ HW and DX Coil																																
43	Building Electric Motor																																
44	Building Natural Gas Meter																																
45	W/Temperature & Humidity Sensor																																
46	Outdoor Temperature Sensor w/Humidistat																																
47	Air Cooled Chiller						\$1,411																		\$1,411								
48	Smart Field Panel	\$1,000				\$1,000		\$1,000		\$1,000		\$1,000		\$1,000		\$1,000		\$1,000		\$1,000		\$1,000		\$1,000		\$1,000		\$1,000					
49	Remote Terminal Unit						\$1,200		\$1,200		\$1,200		\$1,200		\$1,200		\$1,200		\$1,200		\$1,200		\$1,200		\$1,200		\$1,200						
	TOTALS	\$16,110				\$1,000	\$10,000		\$16,110	\$11,000	\$10,000		\$11,000	\$17,000	\$10,000	\$17,000		\$17,000		\$17,000		\$17,000		\$17,000		\$17,000		\$17,000					

BUILDING and Terminal Units	SYSTEM COST BY BUILDING for Smart Field Panels & Remote Terminal Units	SYSTEM COST BY BUILDING for Smart Field Panels & Remote Terminal Units	SYSTEM COST BY BUILDING for Smart Field Panels & Remote Terminal Units	SYSTEM COST BY BUILDING for Smart Field Panels & Remote Terminal Units	SYSTEM COST for Smart Field Panels &
---------------------------------------	--	--	--	--	--

BLDG	Building Numbers:				Building Numbers:				Building Numbers:				Building Numbers:				Building			
	101	102	103	104	101	102	103	104	101	102	103	104	101	102	103	104	101	102	103	104
System	System	System	System	System	System	System	System	System	System	System	System	System	System	System	System	System	System	System	System	System
Cost	Cost	Cost	Cost	Cost	Cost	Cost	Cost	Cost	Cost	Cost	Cost	Cost	Cost	Cost	Cost	Cost	Cost	Cost	Cost	Cost
								\$3,240				\$3,240				\$3,240				
																\$9,336				
		\$8,000			\$8,000		\$8,000	\$8,000												
							\$11,772													
								\$30,378												\$21,761
												\$3,600								
					\$8,877				\$8,134										\$7,308	\$8,348
\$25,701									\$18,174											\$2,813
			\$8,700	\$8,697	\$8,613															
0001																				0001
\$8,221					\$8,221												\$70,679			\$8,221
\$8,000	\$8,000				\$8,000	\$8,000	\$8,000		\$8,000	\$8,000	\$8,000		\$8,000				\$8,000	\$8,000	\$8,000	\$8,000
\$8,324																				
\$7,200	\$64,200	\$20,200	\$7,200		\$62,200	\$26,700	\$7,200		\$84,770	\$28,000	\$7,400	\$4,340	\$6,340	\$4,320			\$88,000	\$74,070	\$88,000	\$79,770

SYSTEM COST BY BUILDING
for Smart Field Panels & Remote Terminal Units

SYSTEM COST BY BUILDING
for Smart Field Panels & Remote Terminal Units

SYSTEM COST BY BUILDING
for Smart Field Panels & Remote Terminal Units

SYSTEM COST BY BUILDING
for Smart Field Panels & Remote Terminal Units

Building Numbers										Building Numbers										Building Numbers										Building Numbers																	
101				102				103				104				105				106				107				108				109				110											
System	Panel	Terminal	Cost	System	Panel	Terminal	Cost	System	Panel	Terminal	Cost	System	Panel	Terminal	Cost	System	Panel	Terminal	Cost	System	Panel	Terminal	Cost	System	Panel	Terminal	Cost	System	Panel	Terminal	Cost	System	Panel	Terminal	Cost	System	Panel	Terminal	Cost	System	Panel	Terminal	Cost	System	Panel	Terminal	Cost
			\$1,000				\$1,000				\$1,000				\$1,000				\$1,000				\$1,000				\$1,000				\$1,000				\$1,000				\$1,000				\$1,000				
			\$1,700								\$1,100								\$1,300				\$1,470				\$1,300																				
			\$1,770																				\$1,700																								
							\$1,800																																								
			\$1,200																																												
			\$19,170																																												
			\$1,600																																												
			\$1,800																																												

SYSTEM COSTS SHEET

for Unitary Controllers & Universal Programmable Controllers

Site: FORT GEORGE G. MEADE
 Date: JULY 1996
 Name: Craig Snyder - Estech Engineering
 Phone: 618-373-6667

Item	Description	DDC				Impervious			
		System Material Cost	Labour in Hours	Cost per Hour	Total System Cost	System Material Cost	Labour in Hours	Cost per Hour	Total System Cost
1	Steam HW Converter (Fig 8-1 & 9-1)	\$4,933	32	\$154.16	\$5,317	\$4,933	34	\$145.09	\$5,317
2	Hot Water Boiler (Fig 8-2 & 9-2)	\$14,235	54	\$263.61	\$15,660	\$14,235	54	\$263.61	\$15,660
3	Hot Water Boiler w/CV Loop (Fig 8-3 & 9-3)	\$14,719	61	\$241.30	\$15,330	\$14,719	61	\$241.30	\$15,330
4	High Temp. HW/HW Converter (Fig 8-4 & 9-4)	\$4,193	28	\$149.75	\$4,586	\$4,193	30	\$139.77	\$4,586
5	Secondary Pumping (Fig. 8-1, 2, 3, 4 & 9-1, 2, 3, 4)	\$2,118	39	\$54.31	\$2,511	\$2,118	39	\$54.31	\$2,511
6	Steam HW Converter Dual Temp (Fig 8-5 & 9-5)	\$6,533	49	\$133.33	\$7,066	\$6,533	51	\$128.10	\$7,066
7	High Temp. HW/HW Converter Dual Temp (Fig 8-4 & 9-4)	\$4,793	46	\$104.20	\$5,262	\$4,793	48	\$99.85	\$5,262
8	Dual Temp Sys w/CV HW Loop Boiler and Air Cooled Chiller (Fig 8-2, 8-3, 9-2)	\$17,494	183	\$95.59	\$18,349	\$17,494	183	\$95.59	\$18,349
9	Dual Temp Sys Boiler and Air Cooled Chiller (Fig 8-8 & 9-8)	\$17,111	96	\$177.10	\$18,082	\$17,111	98	\$174.60	\$18,082
10	Water Cooled Chiller (Fig 8-9 & 9-9)	\$12,792	96	\$133.25	\$13,924	\$12,792	97	\$131.87	\$13,924
11	Multi Zone AH W/ HW and CHW Coils (Fig 8-10 & 9-10)	\$2,816	43	\$65.49	\$3,270	\$2,816	41	\$68.68	\$3,270
12	Dual Duct AH W/ HW and CHW Coils (Fig 8-11 & 9-11)	\$2,816	43	\$65.49	\$3,270	\$2,816	47	\$59.91	\$3,270
13	Bypass Multi Zone AH W/ HW and CHW Coils (Fig 8-12 & 9-12)	\$2,399	48	\$49.98	\$2,848	\$2,399	44	\$54.50	\$2,848
14	VAV AH W/ HW and CHW Coils (Fig 8-13 & 9-13)	\$2,877	54	\$53.28	\$3,410	\$2,877	45	\$64.82	\$3,410
15	VAV AH W/ HW and CHW Coils and Ret. Fan (Fig 8-14 & 9-14)	\$11,461	96	\$119.38	\$12,654	\$11,461	99	\$115.71	\$12,654
16	Single Zone AH W/ HW and CHW Coils (Fig 8-15 & 9-15)	\$2,893	48	\$60.27	\$3,495	\$2,893	33	\$87.67	\$3,495
17	Single Zone AH W/ HW and CHW Coils & Humidification (Fig 8-16 & 9-16)	\$2,199	44	\$49.98	\$2,698	\$2,199	43	\$51.12	\$2,698
18	Single Zone AH W/ HW and DX Coils (Fig 8-17 & 9-17)	\$2,464	44	\$56.00	\$3,024	\$2,464	48	\$51.33	\$3,024
19	Heating and Ventilating (Fig 8-18 & 9-18)	\$1,145	29	\$39.48	\$1,439	\$1,145	29	\$39.48	\$1,439
20	VAV Box DDC Control or Space Temp.	\$643	4	\$160.75	\$707	\$643	3	\$214.33	\$707
21	Steam Boiler (Fig 9-19)	\$64,477	116	\$555.84	\$70,034	\$64,477	116	\$555.84	\$70,034
22	Hot Water Boiler (Fig 9-20)	\$68,895	79	\$872.09	\$75,715	\$68,895	79	\$872.09	\$75,715
23	Electric Dom. HW System (Fig 9-21)	\$666	13	\$51.23	\$718	\$666	13	\$51.23	\$718
24	Oil/Gas Dom. HW System (Fig 9-22)	\$4,855	41	\$118.41	\$5,073	\$4,855	41	\$118.41	\$5,073
25	Steam Dom. HW System (Fig 9-23)	\$642	18	\$35.67	\$677	\$642	18	\$35.67	\$677
26	Steam Unit Heater (Fig 9-24)	\$150	7	\$21.43	\$165	\$150	7	\$21.43	\$165
27	Hot Water Unit Heater (Fig 9-25)	\$150	7	\$21.43	\$165	\$150	7	\$21.43	\$165
28	Electric Unit Heater (Fig 9-26)	\$152	6	\$25.33	\$158	\$152	6	\$25.33	\$158
29	Electric Radiation (Fig 9-27)	\$152	6	\$25.33	\$158	\$152	6	\$25.33	\$158
30	Lighting Control (9-28)	\$688	19	\$36.21	\$724	\$688	19	\$36.21	\$724
31	Lighting Override Switches	\$78	8.28	\$9.42	\$86	\$78	8.28	\$9.42	\$86
32	Water Storage and Distribution System (Fig 9-30)	\$6,758	13	\$519.85	\$7,278	\$6,758	13	\$519.85	\$7,278
33	Sewage LAR System (Fig 9-31)	\$813	15	\$54.20	\$867	\$813	15	\$54.20	\$867
34	Second Pumps (Duplex)	\$788	11	\$71.64	\$859	\$788	11	\$71.64	\$859
35	Additional Pumps (CHW and HW)	\$788	11	\$71.64	\$859	\$788	11	\$71.64	\$859
36	Air Cooled DX Compressor	\$436	8	\$54.50	\$490	\$436	8	\$54.50	\$490
37	Gas/Oil Fired Furnace	\$375	12	\$31.25	\$375	\$375	12	\$31.25	\$375
38	Single Zone DX Coil	\$2,377	44	\$54.02	\$2,817	\$2,377	33	\$71.99	\$2,817
39	Single Zone DX Coil w/Gas Heat	\$2,377	44	\$54.02	\$2,817	\$2,377	33	\$71.99	\$2,817
40	Roof Top Package Unit	\$375	12	\$31.25	\$375	\$375	12	\$31.25	\$375
41	Roof Top Package Unit w/Gas Heat	\$375	12	\$31.25	\$375	\$375	12	\$31.25	\$375
42	Multi-Zone AH w/ HW and DX Coils	\$2,364	41	\$57.66	\$2,840	\$2,364	35	\$67.54	\$2,840
43	Building Electric Meter	\$1,974.00	21	\$94.00	\$1,974.00	\$1,974.00	21	\$94.00	\$1,974.00
44	Building Natural Gas Meter	\$689.00	3	\$229.67	\$689.00	\$689.00	3	\$229.67	\$689.00
45	TEMPERATURE SENSORS W/Temperature & Humidity Sensors	\$682.00	7	\$97.43	\$682.00	\$682.00	7	\$97.43	\$682.00
46	Outdoor Temperature Sensor w/Summertime	\$212.00	2	\$106.00	\$212.00	\$212.00	2	\$106.00	\$212.00
47	Air Cooled Chiller	\$6,818.00	49	\$139.14	\$7,507.00	\$6,818.00	51	\$133.69	\$7,507.00
48	Unitary Controller	\$288.00	2	\$144.00	\$288.00	\$288.00	2	\$144.00	\$288.00
49	Universal Programmable Controller	\$688.00	3	\$229.33	\$688.00	\$688.00	3	\$229.33	\$688.00
50	Smart Field Panel	\$2,688.00	16	\$168.00	\$2,688.00	\$2,688.00	16	\$168.00	\$2,688.00

System No.	Description	Building Numbers																							
		B1	B2	B3	B4	B5	B6	B7	B8	B9	B10	B11	B12	B13	B14	B15	B16	B17	B18	B19	B20	B21	B22	B23	B24
1	Steam HW Converter (Fig 9-1 & 9-1)																								
2	Hot Water Boiler (Fig 9-2 & 2)			1																					
3	Hot Water Boiler w/CV Loop (Fig 9-2 & 9-2)																								
4	High Temp. HW/WH Converter (Fig 9-4 & 9-4)																								
5	Secondary Pumping (Fig. 9-1, 2, 3, 4 & 9-1, 2, 3, 4)																								
6	Steam HW Converter Heat Pump (Fig 9-4 & 9-5)																								
7	High Temp. HW/WH Converter Heat Pump (Fig 9-4 & 9-5)																								
8	Loop Boiler and Air Cooled Chiller (Fig 9-6 & 9-6)																								
9	Heat Exchanger and Air Cooled Chiller (Fig 9-6 & 9-6)																								
10	Water Cooled Chiller (Fig 9-6 & 9-6)																								
11	Multi-Zone AH W/ HW and CW/WH Coils (Fig 9-10 & 9-10)																								
12	Heat Exchanger and Air Cooled Chiller (Fig 9-11 & 9-11)																								
13	HW and CW/WH Coils (Fig 9-11 & 9-11)																								
14	VAV AH W/ HW and CW/WH Coils (Fig 9-13 & 9-13)																								
15	VAV AH W/ HW and CW/WH Coils and Rel. Pan (Fig 9-14 & 9-14)																								
16	Single Zone AH W/ HW and CW/WH Coils (Fig 9-16 & 9-16)																								
17	Single Zone AH W/ HW and CW/WH Coils & Humidification (Fig 9-16 & 9-16)																								
18	Single Zone AH W/ HW and DX Coils (Fig 9-17 & 9-17)																								
19	Heating and Ventilating (Fig 9-18 & 9-18)																								
20	VAV Box DDC Control or Space Temp.																								
21	Steam Boiler (Fig 9-19)																								
22	Hot Water Boiler (Fig 9-20)																								
23	Electric Heat, HW System (Fig 9-21)																								
24	Oil/Gas Heat, HW System (Fig 9-22)																								
25	Steam Heat, HW System (Fig 9-23)																								
26	Steam Unit Heater (Fig 9-24)																								
27	Hot Water Unit Heater (Fig 9-25)																								
28	Electric Unit Heater (Fig 9-26)																								
29	Electric Radiators (Fig 9-27)																								
30	Lighting Control (9-28)																								
31	Lighting Override Station																								
32	Water Storage Tank																								
33	Refrigeration System (Fig 9-29)																								
34	Storage Lift System (Fig 9-31)																								
35	Roof Top Package																								
36	Additional Pumps (CEW and HW)																								
37	Air Cooled DX Compressor																								
38	Gas/Oil Fired Furnace																								
39	Single Zone DX Coil																								
40	Single Zone DX Coil w/ Gas Heat																								
41	Roof Top Package Unit																								
42	Roof Top Package Unit w/ Gas Heat																								
43	Multi-Zone AH w/ HW and DX Coils																								
44	Building Electric Meter																								
45	Building Natural Gas Meter																								
46	W/T Temperature & Humidity Sensor																								
47	Outdoor Temperature Sensor w/ Humidity																								
48	Air Cooled Chiller																								
49	Unitary Controller					3																			
50	Universal Programmable Controller					3																			
51	Smart Field Panel																								

		SYSTEM COSTS BY BUILDING for Utility Controllers and Universal Programmable Controllers								SYSTEM COSTS BY BUILDING for Utility Controllers and Universal Programmable Controllers								SYSTEM COSTS BY BUILDING for Utility Controllers and Universal Programmable Controllers								SYSTEM CC for Utility Controllers and Use			
Site: FORT GEORGE G. MEADE Date: JULY 1996 Name: Craig Snyder - Entech Engineering Phone: 610-373-6647		Building Numbers								Building Numbers								Building Numbers								Building			
		279		279		279		279		279		279		279		279		279		279		279		279		279		279	
		System Costs	System Costs	System Costs	System Costs	System Costs	System Costs	System Costs	System Costs	System Costs	System Costs	System Costs	System Costs	System Costs	System Costs	System Costs	System Costs	System Costs	System Costs	System Costs	System Costs	System Costs	System Costs	System Costs	System Costs	System Costs	System Costs	System Costs	System Costs
1	Steam RW Converter (Pg 8-1 & 8-1)																												
2	Hot Water Boiler (Pg 8-3 & 9-3)																												
3	Hot Water Boiler w/CV Loop (Pg 8-3 & 9-3)																												
4	High Temp. RW/RW Converter (Pg 8-4 & 9-4)																												
5	Secondary Pumping (Pg. 8-1, 2, 3, 4 & 9-1, 2, 3, 4)																												
6	Steam RW Converter Dual Temp (Pg 8-4 & 9-5)																												
7	High Temp. RW/RW Converter Dual Temp (Pg 8-4)																												
8	Loop Boiler w/ CV RW Loop (Pg. 8.3, 8.4, 8.5)																												
9	Hot Temp. RW Boiler and Air Cooled Chiller (Pg 8-5 & 9-5)																												
10	Water Cooled Chiller (Pg 8-7 & 9-7)																												
11	Multi Zone AH W/ RW and CW/ CW Coils (Pg 8-10 & 9-10)																												
12	Dual Zone AH W/ RW and CW/ CW Coils (Pg 8-11 & 9-11)																												
13	RW and CW/ CW Coils (Pg 8-12 & 9-12)																												
14	VAV AH W/ RW and CW/ CW Coils (Pg 8-13 & 9-13)																												
15	VAV RW/RW/RW/RW Coils and Rel. Fan (Pg 8-14 & 9-14)																												
16	Single Zone AH W/ RW and CW/ CW Coils (Pg 8-15 & 9-15)																												
17	Single Zone RW/RW/RW and CW/ CW Coils & Humidification (Pg 8-16 & 9-16)																												
18	Single Zone AH W/ RW and CW Coils (Pg 8-17 & 9-17)																												
19	Heating and Ventilating (Pg 8-18 & 9-18)																												
20	VAV Box DDC Control or System Temp.																												
21	Steam Boiler (Pg 8-19)																												
22	Hot Water Boiler (Pg 8-20)																												
23	Electric Steam, RW System (Pg 9-21)																												
24	Gas/Gas Steam, RW System (Pg 9-22)																												
25	Steam Steam, RW System (Pg 9-23)																												
26	Steam Unit Heater (Pg 9-24)																												
27	Hot Water Unit Heater (Pg 9-25)																												
28	Electric Unit Heater (Pg 9-26)																												
29	Electric Radiation (Pg 9-27)																												
30	Lighting Control (9-28)				81,873		81,873		81,873																		81,873		
31	Lighting Override Buttons				811		811		876																		811		
32	Water Storage and Distribution System (Pg 9-29)																												
33	Storage Lift System (Pg 9-31)																												
34	Control Panels (Diagrams)																												
35	Additional Pumps (CW/ RW and RW)																												
36	Air Cooled BX Compressor																												
37	Gas/Gas Flood Purge																												
38	Single Zone BX Coil				81,710																								
39	Single Zone BX Coil w/Gas Heat																												
40	Roof Top Package Unit																												
41	Roof Top Package Unit w/Gas Heat																												
42	Multi-Zone AH w/ RW and BX Coils																												
43	Building Electric Motor																												
44	Building Natural Gas Motor																												
45	Temperature & Humidity Sensor																												
46	Outdoor Temperature Sensor w/ Humidifier																												
47	Air Cooled Chiller																												
48	Utility Controller																												
49	Universal Programmable Controller				883		883		883																			883	
50	Smart Field Panel																												
TOTALS					88,888		81,774		81,314																		81,774		

SYSTEM COSTS BY BUILDING for Utility Contractors and Universal Programmable Contractors	SYSTEM COSTS BY BUILDING for Utility Contractors and Universal Programmable Contractors	SYSTEM COSTS BY BUILDING for Utility Contractors and Universal Programmable Contractors	SYSTEM COSTS BY BUILDING for Utility Contractors and Universal Programmable Contractors
---	---	---	---

Code	Building Numbers								Building Numbers								Building Numbers								Building Numbers																	
	W01	W02	W03	W04	W05	W06	W07	W08	S01	S02	S03	S04	S05	S06	S07	S08	W09	W10	W11	W12	W13	W14	W15	W16	W17	W18	S09	S10	S11	S12	S13	S14	S15	S16								

SYSTEM-WIDE INPUT

Site: **FORT GEORGE G. MEADE** Name: **Craig Snyder - Entech Engineering**
 Date: **JULY 1996** Phone: **610-373-6667**

Descriptions	Number		Material Cost	Labor Rate \$	Hours	Labor Cost	Total Material Cost	Total Labor Cost	Total Cost
Section 16370—Electrical Distribution System, Aerial									
Crossarm assembly		Each	\$130.00	\$27.50	5	\$137.50	\$0	\$0	\$0
Wood pole		Each	\$460.00	\$27.50	15	\$412.50	\$0	\$0	\$0
Pole line hardware			\$110.00	\$27.50	0	\$0.00	\$0	\$0	\$0
Section 16792—Wireline Data Transmission System									
Surge protector	40	Each	\$60.00	\$27.50	2	\$55.00	\$2,400	\$2,200	\$4,600
Wire line modem	5	Each	\$480.00	\$27.50	4	\$110.00	\$2,400	\$550	\$2,950
Wire line driver	35	Each	\$130.00	\$27.50	1	\$27.50	\$4,550	\$963	\$5,513
Cable, 2-pr, exist duct bank	22000	foot	\$0.34	\$27.50	0.02	\$0.55	\$7,480	\$12,100	\$19,580
Cable, 2-pr, aerial		foot	\$0.34	\$27.50	0.02	\$0.55	\$0	\$0	\$0
Cable, 2-pr, direct burial	56000	foot	\$0.41	\$27.50	0.01	\$0.28	\$22,960	\$15,400	\$38,360
Cable, 2-pr, direct burial, armored		foot	\$0.70	\$27.50	0.01	\$0.28	\$0	\$0	\$0
Cable, 2-pr, indoor	3000	foot	\$0.39	\$27.50	0.01	\$0.28	\$1,170	\$825	\$1,995
Messenger cable, aerial		foot	\$0.33	\$27.50	0.01	\$0.28	\$0	\$0	\$0
Section 16795—Fiber Optics Data Transmission System									
FO modem (800nm)		Each	\$490.00	\$27.50	3	\$82.50	\$0	\$0	\$0
FO transmitter (800 nm)		Each	\$420.00	\$27.50	1	\$27.50	\$0	\$0	\$0
FO receiver (800 nm)		Each	\$420.00	\$27.50	1	\$27.50	\$0	\$0	\$0
FO digital repeater (800 nm)		Each	\$210.00	\$27.50	1	\$27.50	\$0	\$0	\$0
FO modem (1300 nm)		Each	\$490.00	\$27.50	3	\$82.50	\$0	\$0	\$0
FO transmitter (1300 nm)		Each	\$420.00	\$27.50	1	\$27.50	\$0	\$0	\$0
FO receiver (1300 nm)		Each	\$420.00	\$27.50	1	\$27.50	\$0	\$0	\$0
FO digital repeater (1300 nm)		Each	\$210.00	\$27.50	1	\$27.50	\$0	\$0	\$0
FO to 485 Converter		Each	\$450.00	\$27.50	3	\$82.50	\$0	\$0	\$0
FO cable, 4-fiber, aerial		foot	\$2.90	\$27.50	0.01	\$0.28	\$0	\$0	\$0
FO cable, 12-fiber, aerial		foot	\$4.10	\$27.50	0.01	\$0.28	\$0	\$0	\$0
FO cable, 4-fiber, direct burial, armored		foot	\$1.40	\$27.50	0.02	\$0.55	\$0	\$0	\$0
FO cable, 12-fiber, direct burial, armored		foot	\$2.60	\$27.50	0.02	\$0.55	\$0	\$0	\$0
FO cable, 4-fiber, exist duct bank		foot	\$2.90	\$27.50	0.01	\$0.28	\$0	\$0	\$0
FO cable, 12-fiber, exist duct bank		foot	\$4.10	\$27.50	0.01	\$0.28	\$0	\$0	\$0
FO cable, 4-fiber, indoor		foot	\$1.05	\$27.50	0.01	\$0.28	\$0	\$0	\$0
FO connector		Each	\$17.00	\$27.50	1	\$27.50	\$0	\$0	\$0
FO splice closure		Each	\$190.00	\$27.50	3	\$82.50	\$0	\$0	\$0
FO active star unit (ASU), 4 optical paths		Each	\$2,100.00	\$27.50	8	\$220.00	\$0	\$0	\$0
FO ASU, expansion to 4 additional paths		Each	\$2,100.00	\$27.50	8	\$220.00	\$0	\$0	\$0
FO ASU, subsequent expansions, 4 paths		Each	\$2,100.00	\$27.50	8	\$220.00	\$0	\$0	\$0
Section 16797—One-Way Radio Control									
Command generator, 1-way		Each	\$15,000.00	\$27.50	6	\$165.00	\$0	\$0	\$0
Transmitter, 1-way RF		Each	\$8,050.00	\$27.50	11	\$302.50	\$0	\$0	\$0
Backup transmitter, 1-way RF		Each	\$8,050.00	\$27.50	11	\$302.50	\$0	\$0	\$0
Antenna system, 1-way		Each	\$570.00	\$27.50	25	\$687.50	\$0	\$0	\$0
Transmission line to antenna	50 ft		\$240.00	\$27.50	5	\$137.50	\$0	\$0	\$0
Radio switch, 1-way		Each	\$180.00	\$27.50	3	\$82.50	\$0	\$0	\$0
Portable radio switch test unit, 1-way		Each	\$540.00	\$27.50	0	\$0.00	\$0	\$0	\$0
Section 16798—Two-Way Radio Control									
Headend transceiver & comm controller		Each	\$7,510.00	\$27.50	78	\$2,145.00	\$0	\$0	\$0
Standby transceiver		Each	\$7,470.00	\$27.50	27	\$742.50	\$0	\$0	\$0
Remote transceiver w/ antenna		Each	\$1,400.00	\$27.50	7	\$192.50	\$0	\$0	\$0
Repeater, 2-way RF		Each	\$4,110.00	\$27.50	30	\$825.00	\$0	\$0	\$0
Standby repeater, 2-way RF		Each	\$5,550.00	\$27.50	20	\$550.00	\$0	\$0	\$0
Headend antenna & tower, 2-way		Each	\$2,020.00	\$27.50	51	\$1,402.50	\$0	\$0	\$0
Section 16935—Energy Management System									
Technical data package submittals		Lump Sum		\$27.50		\$0.00	\$0	\$0	\$0
Factory test		Lump Sum		\$27.50		\$0.00	\$0	\$0	\$0
Operator's training I		Lump Sum		\$27.50	195	\$5,362.50	\$0	\$0	\$0
Operator's training II	1	Lump Sum		\$27.50	192	\$5,280.00	\$0	\$5,280	\$5,280
Operator's training III		Lump Sum		\$27.50	503	\$13,832.50	\$0	\$0	\$0
Operator's training IV		Lump Sum		\$27.50	119	\$3,272.50	\$0	\$0	\$0
Maintenance personnel training	1	Lump Sum		\$27.50	170	\$4,675.00	\$0	\$4,675	\$4,675
First year maintenance contract		Lump Sum		\$27.50	0	\$0.00	\$2,970	\$0	\$2,970
Portable Tester	1	Each	\$2,970.00	\$27.50	0	\$0.00	\$6,820	\$165	\$6,985
Test set	1	Each	\$6,820.00	\$27.50	6	\$165.00	\$0	\$0	\$0
Scheduled start/stop program	1	Each	\$1,000.00	\$27.50	0	\$0.00	\$1,000	\$0	\$1,000
Optimum start/stop program	1	Each	\$1,000.00	\$27.50	0	\$0.00	\$1,000	\$0	\$1,000
Demand limiting program	1	Each	\$1,000.00	\$27.50	0	\$0.00	\$1,000	\$0	\$1,000
Day/night setback program	1	Each	\$1,000.00	\$27.50	0	\$0.00	\$1,000	\$0	\$1,000

SYSTEM-WIDE INPUT

Site: FORT GEORGE G. MEADE Name: Craig Snyder - Entech Engineering
Date: JULY 1996 Phone: 610-373-6667

Descriptions	Number		Material Cost	Labor Rate \$	Hours	Labor Cost	Total Material Cost	Total Labor Cost	Total Cost
Economizer program	1	Each	\$1,000.00	\$27.50	0	\$0.00	\$1,000	\$0	\$1,000
Ventilation/recirculation program	1	Each	\$1,000.00	\$27.50	0	\$0.00	\$1,000	\$0	\$1,000
Hot deck/cold deck temp reset program	1	Each	\$1,000.00	\$27.50	0	\$0.00	\$1,000	\$0	\$1,000
Reheat coil reset program		Each	\$1,000.00	\$27.50	0	\$0.00	\$0	\$0	\$0
Heating and ventilating unit program	1	Each	\$1,000.00	\$27.50	0	\$0.00	\$1,000	\$0	\$1,000
Air volume control program		Each	\$1,000.00	\$27.50	0	\$0.00	\$0	\$0	\$0
Air distribution terminal unit UCU software		Each	\$1,000.00	\$27.50	0	\$0.00	\$0	\$0	\$0
Chiller efficiency program		Each	\$1,000.00	\$27.50	0	\$0.00	\$0	\$0	\$0
Absorption chiller efficiency and monitoring pgn.		Each	\$1,000.00	\$27.50	0	\$0.00	\$0	\$0	\$0
Chiller water temperature reset program	1	Each	\$1,000.00	\$27.50	0	\$0.00	\$1,000	\$0	\$1,000
Condenser water temperature reset program	1	Each	\$1,000.00	\$27.50	0	\$0.00	\$1,000	\$0	\$1,000
Chiller demand limiting program	1	Each	\$1,000.00	\$27.50	0	\$0.00	\$1,000	\$0	\$1,000
Hot water outside air reset program	1	Each	\$1,000.00	\$27.50	0	\$0.00	\$1,000	\$0	\$1,000
Boiler monitoring and control program	1	Each	\$1,000.00	\$27.50	0	\$0.00	\$1,000	\$0	\$1,000
Hot water distribution program		Each	\$1,000.00	\$27.50	0	\$0.00	\$0	\$0	\$0
Domestic hot water generator program		Each	\$1,000.00	\$27.50	0	\$0.00	\$0	\$0	\$0
Lighting control program	1	Each	\$1,000.00	\$27.50	0	\$0.00	\$1,000	\$0	\$1,000
Equipment electrical consumption program		Each	\$1,000.00	\$27.50	0	\$0.00	\$0	\$0	\$0
Water distribution monitoring and control pgn		Each	\$1,000.00	\$27.50	0	\$0.00	\$0	\$0	\$0
Sewage system monitoring and control pgn		Each	\$1,000.00	\$27.50	0	\$0.00	\$0	\$0	\$0
Central station computer	1	Each	\$12,500.00	\$27.50	40	\$1,100.00	\$12,500	\$1,100	\$13,600
Dot Matrix, Alarm Printer	1	Each	\$400.00	\$27.50	5	\$137.50	\$400	\$138	\$538
Laser Printer	2	Each	\$2,150.00	\$27.50	10	\$275.00	\$4,300	\$550	\$4,850
Network Laser Printer		Each	\$2,150.00	\$27.50	10	\$275.00	\$0	\$0	\$0
Network Color Printer		Each	\$2,900.00	\$27.50	8	\$220.00	\$0	\$0	\$0
Security Type Dial-Up Modem	1	Each	\$1,437.00	\$27.50	5	\$137.50	\$1,437	\$138	\$1,575
Island Station		Each	\$12,500.00	\$27.50	40	\$1,100.00	\$0	\$0	\$0
Uninterruptible power supply, central, 5 kVa		Each	\$5,400.00	\$27.50	5	\$137.50	\$0	\$0	\$0
remote work station			\$8,500.00		15				
Central station console & accessories	1	Lump Sum	\$800.00	\$27.50	3	\$82.50	\$800	\$83	\$883
Operating system and command software	1	Lump Sum	\$11,550.00	\$27.50	0	\$0.00	\$11,550	\$0	\$11,550
LAN system software	1	Lump Sum	\$1,000.00	\$27.50	0	\$0.00	\$1,000	\$0	\$1,000
LAN interface cards	2	Each	\$63.00	\$27.50	0.50	\$13.75	\$126	\$28	\$154
Existing Communication System Interface (Separate estimate required)		Lump Sum	\$0.00	\$0.00	0	\$0.00	\$0	\$0	\$0
Data base generation	2926	Point		\$20.00	0.95	\$19.00	\$0	\$55,594	\$55,594
Graphic display generation	175	diagram		\$20.00	6	\$120.00	\$0	\$21,000	\$21,000
Central station supplies	1	Lump Sum	\$500.00	\$27.50	0	\$0.00	\$500	\$0	\$500
Existing conditions report		Point		\$27.50	1	\$27.50	\$0	\$0	\$0
HVAC system balance, adjust & test		Hours		\$27.50	0	\$0.00	\$0	\$0	\$0
Testing of chiller and boiler control panels	8	Hours		\$27.50	1	\$27.50	\$0	\$220	\$220
Testing, Adjusting, and Commissioning (digital)	1171	Point		\$27.50	0.3	\$9.08	\$0	\$10,627	\$10,627
Testing, Adjusting, and Commissioning (analog)	1755	Point		\$27.50	0.3	\$9.08	\$0	\$15,927	\$15,927
Performance verification test		Hours		\$27.50	0	\$0.00	\$0	\$0	\$0
Endurance test		Hours		\$27.50	0	\$0.00	\$0	\$0	\$0
Opposite season test		Hours		\$27.50	0	\$0.00	\$0	\$0	\$0
Miscellaneous Installation Materials		Lump Sum		\$27.50	0	\$0.00	\$0	\$0	\$0
Equipment Rental		Lump Sum		\$27.50	0	\$0.00	\$0	\$0	\$0
Travel		Lump Sum		\$27.50	0	\$0.00	\$0	\$0	\$0
Quality Control/Quality Assurance		Hours		\$27.50	0	\$0.00	\$0	\$0	\$0
Job Superintendent		Hours		\$27.50	0	\$0.00	\$0	\$0	\$0
Temporary Wiring		Lump Sum		\$27.50	0	\$0.00	\$0	\$0	\$0
Removal of Existing Controls		Lump Sum		\$27.50	0	\$0.00	\$0	\$0	\$0
General purpose laborer		Hours		\$27.50	0	\$0.00	\$0	\$0	\$0
Rubbish Removal		Lump Sum		\$27.50	0	\$0.00	\$0	\$0	\$0
Project Manager		Hours		\$27.50	0	\$0.00	\$0	\$0	\$0
Miscellaneous Supplies		Lump Sum		\$27.50	0	\$0.00	\$0	\$0	\$0
Job Telephone		Lump Sum		\$27.50	0	\$0.00	\$0	\$0	\$0
Temporary Electric		Lump Sum		\$27.50	0	\$0.00	\$0	\$0	\$0
Small Tools		Lump Sum		\$27.50	0	\$0.00	\$0	\$0	\$0
Temporary Job Fence		Lump Sum		\$27.50	0	\$0.00	\$0	\$0	\$0
Office Trailers		Lump Sum		\$27.50	0	\$0.00	\$0	\$0	\$0
Storage Trailers		Lump Sum		\$27.50	0	\$0.00	\$0	\$0	\$0
		Lump Sum		\$27.50	0	\$0.00	\$0	\$0	\$0
		Lump Sum		\$27.50	0	\$0.00	\$0	\$0	\$0
		Lump Sum		\$27.50	0	\$0.00	\$0	\$0	\$0
		Lump Sum		\$27.50	0	\$0.00	\$0	\$0	\$0
		Lump Sum		\$27.50	0	\$0.00	\$0	\$0	\$0
		Lump Sum		\$27.50	0	\$0.00	\$0	\$0	\$0
		Lump Sum		\$27.50	0	\$0.00	\$0	\$0	\$0
		Lump Sum		\$27.50	0	\$0.00	\$0	\$0	\$0
		Lump Sum		\$27.50	0	\$0.00	\$0	\$0	\$0
		Lump Sum		\$27.50	0	\$0.00	\$0	\$0	\$0
		Lump Sum		\$27.50	0	\$0.00	\$0	\$0	\$0
		Lump Sum		\$27.50	0	\$0.00	\$0	\$0	\$0
		Lump Sum		\$27.50	0	\$0.00	\$0	\$0	\$0
		Hours		\$27.50	0	\$0.00	\$0	\$0	\$0
SYSTEM TOTALS							\$97,360	\$147,560	\$244,920

ATTACHMENT SECTION 8.4

UMCS COST ESTIMATE

RECOMMENDED ECO BUILDINGS

SYSTEM COSTS AND INPUT SHEET											
for Smart Field Panels & Remote Terminal Units											
Inputs											
Labor Cost \$ per Hour										\$17.50	
Overhead & Profit in Percentage										20.00%	
Contractors Bond										1.25%	
Escalation in Percentage										3.50%	
Contingency in Percentage										10.00%	
SIOH										5.5%	
System No.	Description	Material Cost	DDC				Total System Cost	Supervisory			
			Labor in Hours	Cost per Hour	Cost per System	Material Cost		Labor in Hours	Cost per Hour	Cost per System	Total System Cost
1	Steam /HW Converter (Fig 8-1 & 9-1)	\$6,132.00	33	\$17.50	\$580	\$6,712.00	\$6,396.00	36	\$17.50	\$624	\$7,020.00
2	Hot Water Boiler (Fig 8-2 & 9-2)	\$14,968.00	86	\$17.50	\$1,495	\$16,463.00	\$14,968.00	86	\$17.50	\$1,495	\$16,463.00
3	Hot Water Boiler w/CV Loop (Fig 8-3 & 9-3)	\$15,464.00	64	\$17.50	\$1,120	\$16,584.00	\$15,464.00	64	\$17.50	\$1,120	\$16,584.00
4	High Temp. HW/HW Converter (Fig 8-4 & 9-4)	\$4,892.00	30	\$17.50	\$525	\$5,417.00	\$4,664.00	32	\$17.50	\$560	\$5,224.00
5	Secondary Pumping (Fig. 8-1, 2, 3, 4 & 9-1, 2, 3, 4)	\$788.00	11	\$17.50	\$193	\$981.00	\$788.00	11	\$17.50	\$193	\$981.00
6	Steam /HW Converter Dual Temp (Fig 8-5 & 9-5)	\$6,177.00	31	\$17.50	\$543	\$6,720.00	\$6,339.00	33	\$17.50	\$578	\$6,917.00
7	High Temp. HW/HW Converter Dual Temp (Fig 8-6 & 9-6)	\$6,437.00	40	\$17.50	\$700	\$7,137.00	\$6,199.00	39	\$17.50	\$683	\$6,882.00
8	Loop Boiler and Air Cooled Chiller (Fig 8-7 & 9-7)	\$18,893.00	100	\$17.50	\$1,750	\$20,643.00	\$18,893.00	100	\$17.50	\$1,750	\$20,643.00
9	Dual Temp Sys Boiler and Air Cooled Chiller (Fig 8-8 & 9-8)	\$18,113.00	100	\$17.50	\$1,750	\$19,863.00	\$16,548.00	93	\$17.50	\$1,628	\$18,176.00
10	Water Cooled Chiller (Fig 8-9 & 9-9)	\$13,894.00	101	\$17.50	\$1,768	\$15,662.00	\$14,843.00	103	\$17.50	\$1,803	\$16,646.00
11	Mult Zone AH W/ HW and CHW Coils (Fig 8-10 & 9-10)	\$3,361.00	66	\$17.50	\$1,155	\$4,516.00	\$3,967.00	43	\$17.50	\$1,183	\$5,150.00
12	Dual Duct AH W/ HW and CHW Coils (Fig 8-11 & 9-11)	\$3,381.00	66	\$17.50	\$1,155	\$4,536.00	\$3,389.00	60	\$17.50	\$1,050	\$4,439.00
13	RYFIRE STURZ GEBELT W/ HW and CHW Coils (Fig 8-12 & 9-12)	\$3,339.00	43	\$17.50	\$753	\$4,092.00	\$3,877.00	47	\$17.50	\$1,233	\$5,110.00
14	VAV AH W/ HW and CHW Coils (Fig 8-13 & 9-13)	\$3,798.00	57	\$17.50	\$998	\$4,796.00	\$3,633.00	48	\$17.50	\$1,320	\$4,953.00
15	VAV AH W/ HW and CHW Coils and Ret. Fan (Fig 8-14 & 9-14)	\$13,854.00	103	\$17.50	\$1,803	\$15,657.00	\$3,877.00	62	\$17.50	\$1,088	\$4,965.00
16	Single Zone AH W/ HW and CHW Coils (Fig 8-15 & 9-15)	\$1,798.00	43	\$17.50	\$753	\$2,551.00	\$2,164.00	36	\$17.50	\$630	\$3,194.00
17	Single Zone AH W/ HW and CHW Coils & Humidification (Fig 8-16 & 9-16)	\$2,558.00	46	\$17.50	\$808	\$3,366.00	\$2,827.00	47	\$17.50	\$1,233	\$4,600.00
18	Single Zone AH W/ HW and D Coils (Fig 8-17 & 9-17)	\$3,666.00	49	\$17.50	\$858	\$4,524.00	\$3,222.00	63	\$17.50	\$1,108	\$4,630.00
19	Heating and Ventilating (Fig 8-18 & 9-18)	\$1,644.00	31	\$17.50	\$543	\$2,187.00	\$1,733.00	32	\$17.50	\$560	\$2,293.00
20	VAV Box DDC Control/ or Space Temp.	\$799.00	7	\$17.50	\$123	\$922.00	\$142.00	3	\$17.50	\$53	\$975.00
21	Steam Boiler (Fig 9-19)	\$48,317.00	117	\$17.50	\$2,048	\$50,365.00	\$48,317.00	117	\$17.50	\$2,048	\$50,365.00
22	Hot Water Boiler (Fig 9-20)	\$61,563.00	91	\$17.50	\$1,593	\$63,156.00	\$61,563.00	91	\$17.50	\$1,593	\$63,156.00
23	Electric Dom. HW System (Fig 9-21)	\$763.00	13	\$17.50	\$228	\$991.00	\$763.00	13	\$17.50	\$228	\$991.00
24	Oil/Gas Dom. HW System (Fig 9-22)	\$5,163.00	43	\$17.50	\$753	\$5,916.00	\$5,163.00	43	\$17.50	\$753	\$5,916.00
25	Steam Dom. HW System (Fig 9-23)	\$781.00	11	\$17.50	\$193	\$974.00	\$781.00	11	\$17.50	\$193	\$974.00
26	Steam Unit Heater (Fig 9-24)	\$281.00	8	\$17.50	\$140	\$421.00	\$281.00	8	\$17.50	\$140	\$421.00
27	Hot Water Unit Heater (Fig 9-25)	\$281.00	8	\$17.50	\$140	\$421.00	\$281.00	8	\$17.50	\$140	\$421.00
28	Electric Unit Heater (Fig 9-26)	\$283.00	6	\$17.50	\$105	\$388.00	\$283.00	6	\$17.50	\$105	\$388.00
29	Electric Radiation (Fig 9-27)	\$283.00	6	\$17.50	\$105	\$388.00	\$283.00	6	\$17.50	\$105	\$388.00
30	Lighting Control (9-28)	\$834.00	21	\$17.50	\$368	\$1,202.00	\$834.00	21	\$17.50	\$368	\$1,202.00
31	Lighting Override Switches	\$78.00	635	\$17.50	\$11,113	\$11,891.00	\$78.00	635	\$17.50	\$11,113	\$11,891.00
32	Water Storage and Distribution System (Fig 9-30)	\$4,398.00	13	\$17.50	\$228	\$4,626.00	\$4,398.00	13	\$17.50	\$228	\$4,626.00
33	Sewage Lift System (Fig 9-31)	\$888.00	16	\$17.50	\$280	\$1,168.00	\$888.00	16	\$17.50	\$280	\$1,168.00
34	Second Pumps (Duplex)	\$788.00	11	\$17.50	\$193	\$981.00	\$788.00	11	\$17.50	\$193	\$981.00
35	Additional Pumps (CHW and HW)	\$788.00	11	\$17.50	\$193	\$981.00	\$788.00	11	\$17.50	\$193	\$981.00
36	Air Cooled DX Compressor	\$667.00	8	\$17.50	\$140	\$807.00	\$667.00	8	\$17.50	\$140	\$807.00
37	Gas/Oil Fired Furnace	\$878.00	11	\$17.50	\$193	\$1,071.00	\$878.00	11	\$17.50	\$193	\$1,071.00
38	Single Zone DX Coil	\$3,881.00	47	\$17.50	\$823	\$4,704.00	\$3,668.00	34	\$17.50	\$595	\$4,263.00
39	Single Zone DX Coil w/Gas Heat	\$3,881.00	47	\$17.50	\$823	\$4,704.00	\$3,668.00	34	\$17.50	\$595	\$4,263.00
40	Roof Top Package Unit	\$578.00	12	\$17.50	\$210	\$788.00	\$578.00	12	\$17.50	\$210	\$788.00
41	Roof Top Package Unit w/ Gas Heat	\$578.00	12	\$17.50	\$210	\$788.00	\$578.00	12	\$17.50	\$210	\$788.00
42	Mult-Zone AH w/ HW and DX Coils	\$3,179.00	45	\$17.50	\$788	\$3,967.00	\$3,179.00	45	\$17.50	\$788	\$3,967.00
43	Building Electric Meter	\$1,974.00	21	\$17.50	\$368	\$2,342.00	\$1,974.00	21	\$17.50	\$368	\$2,342.00
44	Building Natural Gas Meter	\$699.00	3	\$17.50	\$53	\$752.00	\$699.00	3	\$17.50	\$53	\$752.00
45	W/Temperature & Humidity Sensor	\$282.00	7	\$17.50	\$123	\$405.00	\$282.00	7	\$17.50	\$123	\$405.00
46	Outdoor Temperature Sensor w/Sunshield	\$212.00	2	\$17.50	\$35	\$247.00	\$212.00	2	\$17.50	\$35	\$247.00
47	Air Cooled Chiller	\$6,324.00	53	\$17.50	\$923	\$7,247.00	\$6,773.00	53	\$17.50	\$923	\$7,696.00
48	Smart Field Panel	\$2,688.00	16	\$17.50	\$280	\$2,968.00	\$2,688.00	16	\$17.50	\$280	\$2,968.00
49	Remote Terminal Unit	\$2,188.00	8	\$17.50	\$140	\$2,328.00	\$2,188.00	8	\$17.50	\$140	\$2,328.00

SYSTEM COSTS SHEET

for Unitary Controllers & Universal Programmable Controllers

Site: PORT GEORGE G. MEADE
 Date: JULY 1996
 Name: Craig Snyder - Entech Engineering
 Phone: 610-373-6667

Item	Description	DDC				Secondary			
		System Material Cost \$	Labor in Hours	DDC Cost Per Hour	DDC Cost per System	System Material Cost \$	Labor in Hours	Secondary Cost Per Hour	Secondary Cost per System
1	Steam /HW Converter (Fig 8-1 & 8-1)	\$4,813	32	\$17.80	\$880	\$4,813	34	\$17.80	\$948
2	Hot Water Boiler (Fig 8-2 & 8-2)	\$14,328	84	\$17.80	\$1,488	\$14,328	84	\$17.80	\$1,488
3	Hot Water Boiler w/CV Loop (Fig 8-3 & 8-3)	\$14,710	61	\$27.80	\$1,678	\$14,710	61	\$27.80	\$1,678
4	High Temp. HW/HW Converter (Fig 8-4 & 8-4)	\$4,193	28	\$17.80	\$770	\$4,343	30	\$17.80	\$828
5	Secondary Pumping (Fig. 8-1, 2, 3, 4 & 9-1, 2, 3, 4)	\$2,128	39	\$17.80	\$1,073	\$2,128	39	\$17.80	\$1,073
6	Steam /HW Converter Dual Temp (Fig 8-5 & 8-5)	\$5,623	49	\$17.80	\$1,248	\$5,623	51	\$17.80	\$1,403
7	High Temp. HW/HW Converter Dual Temp (Fig 8-6 & 8-6)	\$4,793	46	\$17.80	\$1,248	\$4,817	48	\$17.80	\$1,230
8	Dual Temp Sys W/ CV HW Loop Boiler and Air Cooled Chiller (Fig 8-7 & 8-7)	\$17,496	183	\$17.80	\$2,833	\$17,496	183	\$17.80	\$2,833
9	Dual Temp Sys Boiler and Air Cooled Chiller (Fig 8-8 & 8-8)	\$17,111	96	\$17.80	\$1,640	\$17,781	88	\$17.80	\$1,420
10	Water Cooled Chiller (Fig 8-9 & 8-9)	\$12,782	96	\$17.80	\$1,640	\$12,542	97	\$17.80	\$1,640
11	Multi Zone AH W/ HW and CHW Coils (Fig 8-10 & 8-10)	\$2,816	43	\$17.80	\$1,183	\$2,699	41	\$17.80	\$1,128
12	Dual Duct AH W/ HW and CHW Coils (Fig 8-11 & 8-11)	\$2,816	43	\$17.80	\$1,183	\$2,699	47	\$17.80	\$1,293
13	By-Pass Multi Zone AH W/ HW and CHW Coils (Fig 8-12 & 8-12)	\$2,389	49	\$17.80	\$1,100	\$2,409	44	\$17.80	\$1,210
14	VAV AH W/ HW and CHW Coils (Fig 8-13 & 8-13)	\$2,877	54	\$17.80	\$1,408	\$4,342	48	\$17.80	\$1,230
15	VAV AH W/ HW and CHW Coils and Ret. Fan (Fig 8-14 & 8-14)	\$11,661	96	\$17.80	\$2,440	\$14,341	49	\$17.80	\$1,248
16	Single Zone AH W/ HW and CHW Coils (Fig 8-15 & 8-15)	\$2,893	49	\$17.80	\$1,180	\$2,193	33	\$17.80	\$988
17	Single Zone AH W/ HW and CHW Coils & Humidification (Fig 8-16 & 8-16)	\$2,186	44	\$17.80	\$1,210	\$2,340	43	\$17.80	\$1,183
18	Single Zone AH W/ HW and DX Coils (Fig 8-17 & 8-17)	\$2,664	46	\$17.80	\$1,248	\$2,173	39	\$17.80	\$1,378
19	Heating and Ventilating (Fig 8-18 & 8-18)	\$1,146	39	\$17.80	\$798	\$1,843	39	\$17.80	\$798
20	VAV Box DDC Control or Space Temp.	\$643	4	\$17.80	\$107	\$678	87	\$17.80	\$1,543
21	Steam Boiler (Fig 8-19)	\$64,477	116	\$17.80	\$2,190	\$67,667	116	\$17.80	\$2,190
22	Hot Water Boiler (Fig 8-20)	\$68,698	79	\$17.80	\$1,473	\$68,698	79	\$17.80	\$1,473
23	Electric Down.HW System (Fig 9-21)	\$666	13	\$17.80	\$238	\$896	13	\$17.80	\$238
24	Oil/Gas Down.HW System (Fig 9-22)	\$4,888	41	\$17.80	\$1,130	\$4,868	41	\$17.80	\$1,130
25	Steam Down.HW System (Fig 9-23)	\$643	19	\$17.80	\$378	\$817	19	\$17.80	\$378
26	Steam Unit Heater (Fig 9-24)	\$188	7	\$17.80	\$193	\$188	7	\$17.80	\$193
27	Hot Water Unit Heater (Fig 9-25)	\$188	7	\$17.80	\$193	\$188	7	\$17.80	\$193
28	Electric Unit Heater (Fig 9-26)	\$182	6	\$17.80	\$168	\$182	6	\$17.80	\$168
29	Electric Radiation (Fig 9-27)	\$182	6	\$17.80	\$168	\$182	6	\$17.80	\$168
30	Lighting Control (9-28)	\$889	19	\$17.80	\$823	\$1,073	19	\$17.80	\$823
31	Lighting Override Switches	\$79	6.25	\$17.80	\$77	\$79	6.25	\$17.80	\$77
32	Water Storage and Distribution System (Fig 9-29)	\$4,788	13	\$17.80	\$198	\$7,148	13	\$17.80	\$198
33	Sewage Lift System (Fig 9-31)	\$813	18	\$17.80	\$413	\$1,228	18	\$17.80	\$413
34	Second Pumps (Duplex)	\$788	11	\$17.80	\$343	\$1,811	11	\$17.80	\$343
35	Additional Pumps (CHW and HW)	\$788	11	\$17.80	\$343	\$1,811	11	\$17.80	\$343
36	Air Cooled DX Compressor	\$436	8	\$17.80	\$228	\$666	8	\$17.80	\$228
37	Gas/Oil Fired Furnace	\$378	12	\$17.80	\$336	\$788	12	\$17.80	\$336
38	Single Zone DX Coil	\$2,387	44	\$17.80	\$1,210	\$2,867	33	\$17.80	\$988
39	Single Zone DX Coil w/Gas Heat	\$2,387	44	\$17.80	\$1,210	\$2,867	33	\$17.80	\$988
40	Roof Top Package Unit	\$378	12	\$17.80	\$336	\$788	12	\$17.80	\$336
41	Roof Top Package Unit w Gas Heat	\$378	12	\$17.80	\$336	\$788	12	\$17.80	\$336
42	Multi-Zone AH w HW and DX Coils	\$2,344	42	\$17.80	\$1,144	\$2,819	36	\$17.80	\$963
43	Building Electric Meter	\$1,974.00	21	\$8.00	\$80	\$1,974	21	\$8.00	\$80
44	Building Natural Gas Meter	\$689.00	3	\$8.00	\$80	\$689	3	\$8.00	\$80
45	Distribution Station W/Temperature & Humidity Sensors	\$882.00	7	\$8.00	\$80	\$882	7	\$8.00	\$80
46	Outdoor Temperature Sensor w/Sunshield	\$113.00	1	\$8.00	\$80	\$113	1	\$8.00	\$80
47	Air Cooled Chiller	\$4,818.00	49	\$17.80	\$1,248	\$7,266	81	\$17.80	\$1,483
48	Unitary Controller	\$288.00	3	\$17.80	\$80	\$288	3	\$17.80	\$80
49	Universal Programmable Controller	\$688.00	3	\$17.80	\$80	\$688	3	\$17.80	\$80
50	Smart Field Panel	\$2,488.00	16	\$17.80	\$448	\$2,488	16	\$17.80	\$448

SYSTEM INPUT BY BUILDING
for Unitary Controllers and Universal Programmable Controllers

SYSTEM INPUT BY BUILDING
for Unitary Controllers and Universal Programmable Controllers

Site: **PORT GEORGE G. MEADE**
Date: **JULY 1994**
Prepared by: **Crane Services - Estech Engineering**
Phone: **688-373-6667**

System No.	Description	Building 2111										Building 2218									
		100	101	102	103	104	105	106	107	108	109	100	101	102	103	104	105	106	107	108	109
1	Steam HW Converter (Pg 8-1 & 9-1)																				
2	Hot Water Boiler (Pg 8-2 & 9-2)																				
3	Hot Water Boiler w/ CV Loop (Pg 8-3 & 9-3)																				
4	High Temp. HW/ HW Converter (Pg 8-4 & 9-4)																				
5	Secondary Pumping (Pg. 8-1, 2, 3, 4 & 9-1, 2, 3, 4)																				
6	Steam HW Converter Heat Pump (Pg 8-5 & 9-5)																				
7	High Temp. HW/ HW Converter Heat Pump (Pg 8-6 & 9-6)																				
8	Loop Boiler and Air Cooled Chiller (Pg 8-7, 8-8, 9-7, 9-8)																				
9	High Temp. Hot Water Boiler and Air Cooled Chiller (Pg 8-8 & 9-8)																				
10	Water Cooled Chiller (Pg 8-9 & 9-9)																				
11	Multi Zone AH W/ HW and CW/ CW Cools (Pg 8-10 & 9-10)																				
12	Heat Exch. AH W/ HW and CW/ CW Cools (Pg 8-10 & 9-10)																				
13	HW and CW/ CW Cools (Pg 8-11 & 9-11)																				
14	VAV AH W/ HW and CW/ CW Cools (Pg 8-12 & 9-12)																				
15	VAV/ HW/ HW and CW/ CW Cools and Rot. Fan (Pg 8-13 & 9-13)																				
16	Single Zone AH W/ HW and CW/ CW Cools (Pg 8-14 & 9-14)																				
17	Single Zone AH W/ HW and CW/ CW Cools (Pg 8-15 & 9-15)																				
18	Single Zone AH W/ HW and CW/ CW Cools (Pg 8-16 & 9-16)																				
19	Single Zone AH W/ HW and CW/ CW Cools (Pg 8-17 & 9-17)																				
20	Heating and Ventilating (Pg 8-18 & 9-18)																				
21	VAV Box DDC Control or System Temp.																				
22	Steam Boiler (Pg 9-19)																				
23	Hot Water Boiler (Pg 9-20)																				
24	Electric Dom. HW System (Pg 9-21)																				
25	Gas/ Gas Dom. HW System (Pg 9-22)																				
26	Steam Dom. HW System (Pg 9-23)																				
27	Steam Unit Heater (Pg 9-24)																				
28	Hot Water Unit Heater (Pg 9-25)																				
29	Electric Unit Heater (Pg 9-26)																				
30	Electric Radiation (Pg 9-27)																				
31	Lighting Control (Pg 9-28)																				
32	Lighting Override Switches																				
33	Water Storage and Distribution System (Pg 9-29)																				
34	Storage LH System (Pg 9-31)																				
35	Recirc. Pump (Diaphr.)																				
36	Additional Pump (CW/ HW and HW)																				
37	Air Cooled DX Compressor																				
38	Gas/Oil Fired Furnace																				
39	Single Zone DX Cool																				
40	Single Zone DX Cool w/ Gas Heat																				
41	Roof Top Package Unit																				
42	Roof Top Package Unit w/ Gas Heat																				
43	Multi-Zone AH w/ HW and DX Cools																				
44	Building Electric Meter																				
45	Building Natural Gas Meter																				
46	W/Temperature & Humidity Control																				
47	Outdoor Temperature Sensor																				
48	Air Cooled Chiller																				
49	Unitary Controller																				
50	Universal Programmable Controller																				
51	Roof Top Field Panel																				

①

SYSTEM-WIDE INPUT

Site: FORT GEORGE G. MEADE Name: Craig Snyder - Entech Engineering
Date: JULY 1996 Phone: 610-373-6667

Descriptions	Number		Material Cost	Labor Rate \$	Hours	Labor Cost	Total Material Cost	Total Labor Cost	Total Cost
Section 16370—Electrical Distribution System, Aerial									
Crossarm assembly		Each	\$130.00	\$27.50	5	\$137.50	\$0	\$0	\$0
Wood pole		Each	\$460.00	\$27.50	15	\$412.50	\$0	\$0	\$0
Pole line hardware		Each	\$110.00	\$27.50	0	\$0.00	\$0	\$0	\$0
Section 16792—Wireline Data Transmission System									
Surge protector	20	Each	\$60.00	\$27.50	2	\$55.00	\$1,200	\$1,100	\$2,300
Wire line modem	3	Each	\$480.00	\$27.50	4	\$110.00	\$1,440	\$330	\$1,770
Wire line driver	25	Each	\$130.00	\$27.50	1	\$27.50	\$3,250	\$688	\$3,938
Cable, 2-pr, exist duct bank	12500	foot	\$0.34	\$27.50	0.02	\$0.55	\$4,250	\$6,875	\$11,125
Cable, 2-pr, aerial		foot	\$0.34	\$27.50	0.02	\$0.55	\$0	\$0	\$0
Cable, 2-pr, direct burial	47100	foot	\$0.41	\$27.50	0.01	\$0.28	\$19,311	\$12,953	\$32,264
Cable, 2-pr, direct burial, armored		foot	\$0.79	\$27.50	0.01	\$0.28	\$0	\$0	\$0
Cable, 2-pr, indoor	2500	foot	\$0.39	\$27.50	0.01	\$0.28	\$975	\$688	\$1,663
Messenger cable, aerial		foot	\$0.33	\$27.50	0.01	\$0.28	\$0	\$0	\$0
Section 16795—Fiber Optics Data Transmission System									
FO modem (800nm)		Each	\$490.00	\$27.50	3	\$82.50	\$0	\$0	\$0
FO transmitter (800 nm)		Each	\$420.00	\$27.50	1	\$27.50	\$0	\$0	\$0
FO receiver (800 nm)		Each	\$420.00	\$27.50	1	\$27.50	\$0	\$0	\$0
FO digital repeater (800 nm)		Each	\$210.00	\$27.50	1	\$27.50	\$0	\$0	\$0
FO modem (1300 nm)		Each	\$490.00	\$27.50	3	\$82.50	\$0	\$0	\$0
FO transmitter (1300 nm)		Each	\$420.00	\$27.50	1	\$27.50	\$0	\$0	\$0
FO receiver (1300 nm)		Each	\$420.00	\$27.50	1	\$27.50	\$0	\$0	\$0
FO digital repeater (1300 nm)		Each	\$210.00	\$27.50	1	\$27.50	\$0	\$0	\$0
FO to 485 Converter		Each	\$450.00	\$27.50	3	\$82.50	\$0	\$0	\$0
FO cable, 4-fiber, aerial		foot	\$2.90	\$27.50	0.01	\$0.28	\$0	\$0	\$0
FO cable, 12-fiber, aerial		foot	\$4.10	\$27.50	0.01	\$0.28	\$0	\$0	\$0
FO cable, 4-fiber, direct burial, armored		foot	\$1.40	\$27.50	0.02	\$0.55	\$0	\$0	\$0
FO cable, 12-fiber, direct burial, armored		foot	\$2.60	\$27.50	0.02	\$0.55	\$0	\$0	\$0
FO cable, 4-fiber, exist duct bank		foot	\$2.90	\$27.50	0.01	\$0.28	\$0	\$0	\$0
FO cable, 12-fiber, exist duct bank		foot	\$4.10	\$27.50	0.01	\$0.28	\$0	\$0	\$0
FO cable, 4-fiber, indoor		foot	\$1.05	\$27.50	0.01	\$0.28	\$0	\$0	\$0
FO connector		Each	\$17.00	\$27.50	1	\$27.50	\$0	\$0	\$0
FO splice closure		Each	\$190.00	\$27.50	3	\$82.50	\$0	\$0	\$0
FO active star unit (ASU), 4 optical paths		Each	\$2,100.00	\$27.50	8	\$220.00	\$0	\$0	\$0
FO ASU, expansion to 4 additional paths		Each	\$2,100.00	\$27.50	8	\$220.00	\$0	\$0	\$0
FO ASU, subsequent expansions, 4 paths		Each	\$2,100.00	\$27.50	8	\$220.00	\$0	\$0	\$0
Section 16797—One-Way Radio Control									
Command generator, 1-way		Each	\$15,000.00	\$27.50	6	\$165.00	\$0	\$0	\$0
Transmitter, 1-way RF		Each	\$8,050.00	\$27.50	11	\$302.50	\$0	\$0	\$0
Backup transmitter, 1-way RF		Each	\$8,050.00	\$27.50	11	\$302.50	\$0	\$0	\$0
Antenna system, 1-way		Each	\$370.00	\$27.50	25	\$687.50	\$0	\$0	\$0
Transmission line to antenna	50 ft		\$240.00	\$27.50	5	\$137.50	\$0	\$0	\$0
Radio switch, 1-way		Each	\$180.00	\$27.50	3	\$82.50	\$0	\$0	\$0
Portable radio switch test unit, 1-way		Each	\$540.00	\$27.50	0	\$0.00	\$0	\$0	\$0
Section 16798—Two-Way Radio Control									
Headend transceiver & comm controller		Each	\$7,510.00	\$27.50	78	\$2,145.00	\$0	\$0	\$0
Standby transceiver		Each	\$7,470.00	\$27.50	27	\$742.50	\$0	\$0	\$0
Remote transceiver w/ antenna		Each	\$1,400.00	\$27.50	7	\$192.50	\$0	\$0	\$0
Repeater, 2-way RF		Each	\$4,110.00	\$27.50	30	\$825.00	\$0	\$0	\$0
Standby repeater, 2-way RF		Each	\$5,550.00	\$27.50	20	\$550.00	\$0	\$0	\$0
Headend antenna & tower, 2-way		Each	\$2,020.00	\$27.50	51	\$1,402.50	\$0	\$0	\$0
Section 16835—Energy Management System									
Technical data package submittals		Lump Sum		\$27.50		\$0.00	\$0	\$0	\$0
Factory test		Lump Sum		\$27.50		\$0.00	\$0	\$0	\$0
Operator's training I		Lump Sum		\$27.50	195	\$5,362.50	\$0	\$0	\$0
Operator's training II	1	Lump Sum		\$27.50	192	\$5,280.00	\$0	\$5,280	\$5,280
Operator's training III		Lump Sum		\$27.50	503	\$13,832.50	\$0	\$0	\$0
Operator's training IV		Lump Sum		\$27.50	119	\$3,272.50	\$0	\$0	\$0
Maintenance personnel training	1	Lump Sum		\$27.50	170	\$4,675.00	\$0	\$4,675	\$4,675
First year maintenance contract		Lump Sum		\$27.50	0	\$0.00	\$0	\$0	\$0
Portable Tester	1	Each	\$2,970.00	\$27.50	0	\$0.00	\$2,970	\$0	\$2,970
Test net	1	Each	\$6,820.00	\$27.50	6	\$165.00	\$6,820	\$165	\$6,985
Scheduled start/stop program	1	Each	\$1,000.00	\$27.50	0	\$0.00	\$1,000	\$0	\$1,000
Optimum start/stop program	1	Each	\$1,000.00	\$27.50	0	\$0.00	\$1,000	\$0	\$1,000
Demand limiting program	1	Each	\$1,000.00	\$27.50	0	\$0.00	\$1,000	\$0	\$1,000
Day/night setback program	1	Each	\$1,000.00	\$27.50	0	\$0.00	\$1,000	\$0	\$1,000
Economizer program	1	Each	\$1,000.00	\$27.50	0	\$0.00	\$1,000	\$0	\$1,000

SYSTEM-WIDE INPUT

Site: FORT GEORGE G. MEADE Name: Craig Snyder - Entech Engineering
Date: JULY 1996 Phone: 610-373-6667

Descriptions	Number		Material Cost	Labor Rate \$	Hours	Labor Cost	Total Material Cost	Total Labor Cost	Total Cost
Ventilation/recirculation program	1	Each	\$1,000.00	\$27.50	0	\$0.00	\$1,000	\$0	\$1,000
Hot deck/cold deck temp reset program	1	Each	\$1,000.00	\$27.50	0	\$0.00	\$1,000	\$0	\$1,000
Reheat coil reset program		Each	\$1,000.00	\$27.50	0	\$0.00	\$0	\$0	\$0
Heating and ventilating unit program	1	Each	\$1,000.00	\$27.50	0	\$0.00	\$1,000	\$0	\$1,000
Air volume control program		Each	\$1,000.00	\$27.50	0	\$0.00	\$0	\$0	\$0
Air distribution terminal unit UCU software		Each	\$1,000.00	\$27.50	0	\$0.00	\$0	\$0	\$0
Chiller selection program		Each	\$1,000.00	\$27.50	0	\$0.00	\$0	\$0	\$0
Absorption chiller efficiency and monitoring pgm.		Each	\$1,000.00	\$27.50	0	\$0.00	\$0	\$0	\$0
Chiller water temperature reset program	1	Each	\$1,000.00	\$27.50	0	\$0.00	\$1,000	\$0	\$1,000
Condenser water temperature reset program	1	Each	\$1,000.00	\$27.50	0	\$0.00	\$1,000	\$0	\$1,000
Chiller demand limiting program	1	Each	\$1,000.00	\$27.50	0	\$0.00	\$1,000	\$0	\$1,000
Hot water outside air reset program	1	Each	\$1,000.00	\$27.50	0	\$0.00	\$1,000	\$0	\$1,000
Boiler monitoring and control program	1	Each	\$1,000.00	\$27.50	0	\$0.00	\$1,000	\$0	\$1,000
Hot water distribution program		Each	\$1,000.00	\$27.50	0	\$0.00	\$0	\$0	\$0
Domestic hot water generator program		Each	\$1,000.00	\$27.50	0	\$0.00	\$0	\$0	\$0
Lighting control program	1	Each	\$1,000.00	\$27.50	0	\$0.00	\$1,000	\$0	\$1,000
Equipment electrical consumption program		Each	\$1,000.00	\$27.50	0	\$0.00	\$0	\$0	\$0
Water distribution monitoring and control pgm		Each	\$1,000.00	\$27.50	0	\$0.00	\$0	\$0	\$0
Sewage system monitoring and control pgm		Each	\$1,000.00	\$27.50	0	\$0.00	\$0	\$0	\$0
Central station computer	1	Each	\$12,500.00	\$27.50	40	\$1,100.00	\$12,500	\$1,100	\$13,600
Dot Matrix, Alarm Printer	1	Each	\$400.00	\$27.50	5	\$137.50	\$400	\$138	\$538
Laser Printer	2	Each	\$2,150.00	\$27.50	10	\$275.00	\$4,300	\$550	\$4,850
Network Laser Printer		Each	\$2,150.00	\$27.50	10	\$275.00	\$0	\$0	\$0
Network Color Printer		Each	\$2,900.00	\$27.50	8	\$220.00	\$0	\$0	\$0
Security Type Dial-Up Modem	1	Each	\$1,437.00	\$27.50	5	\$137.50	\$1,437	\$138	\$1,575
Island Station		Each	\$12,500.00	\$27.50	40	\$1,100.00	\$0	\$0	\$0
Uninterruptible power supply, central, 5 kVa remote work station		Each	\$5,400.00	\$27.50	5	\$137.50	\$0	\$0	\$0
			\$8,500.00		15				
Central station console & accessories	1	Lump Sum	\$800.00	\$27.50	3	\$82.50	\$800	\$83	\$883
Operating system and command software	1	Lump Sum	\$11,550.00	\$27.50	0	\$0.00	\$11,550	\$0	\$11,550
LAN system software	1	Lump Sum	\$1,000.00	\$27.50	0	\$0.00	\$1,000	\$0	\$1,000
LAN interface cards	2	Each	\$63.00	\$27.50	0.50	\$13.75	\$126	\$28	\$154
Existing Communication System Interface (Separate estimate required)		Lump Sum	\$0.00	\$0.00	0	\$0.00	\$0	\$0	\$0
Data base generation	1380	Point		\$20.00	0.95	\$19.00	\$0	\$26,220	\$26,220
Graphic display generation	85	diagram		\$20.00	6	\$120.00	\$0	\$10,200	\$10,200
Central station supplies	1	Lump Sum	\$500.00	\$27.50	0	\$0.00	\$500	\$0	\$500
Existing conditions report		Point		\$27.50	1	\$27.50	\$0	\$0	\$0
HVAC system balance, adjust & test		Hours		\$27.50	0	\$0.00	\$0	\$0	\$0
Testing of chiller and boiler control panels	8	Hours		\$27.50	1	\$27.50	\$0	\$220	\$220
Testing, Adjusting, and Commissioning (digital)	552	Point		\$27.50	0.3	\$9.08	\$0	\$5,009	\$5,009
Testing, Adjusting, and Commissioning (analog)	828	Point		\$27.50	0.3	\$9.08	\$0	\$7,514	\$7,514
Performance verification test		Hours		\$27.50	0	\$0.00	\$0	\$0	\$0
Endurance test		Hours		\$27.50	0	\$0.00	\$0	\$0	\$0
Opposite season test		Hours		\$27.50	0	\$0.00	\$0	\$0	\$0
Miscellaneous Installation Materials		Lump Sum		\$27.50	0	\$0.00	\$0	\$0	\$0
Equipment Rental		Lump Sum		\$27.50	0	\$0.00	\$0	\$0	\$0
Travel		Lump Sum		\$27.50	0	\$0.00	\$0	\$0	\$0
Quality Control/Quality Assurance		Hours		\$27.50	0	\$0.00	\$0	\$0	\$0
Job Superintendent		Hours		\$27.50	0	\$0.00	\$0	\$0	\$0
Temporary Wiring		Lump Sum		\$27.50	0	\$0.00	\$0	\$0	\$0
Removal of Existing Controls		Lump Sum		\$27.50	0	\$0.00	\$0	\$0	\$0
General purpose laborer		Hours		\$27.50	0	\$0.00	\$0	\$0	\$0
Rubbish Removal		Lump Sum		\$27.50	0	\$0.00	\$0	\$0	\$0
Project Manager		Hours		\$27.50	0	\$0.00	\$0	\$0	\$0
Miscellaneous Supplies		Lump Sum		\$27.50	0	\$0.00	\$0	\$0	\$0
Job Telephone		Lump Sum		\$27.50	0	\$0.00	\$0	\$0	\$0
Temporary Electric		Lump Sum		\$27.50	0	\$0.00	\$0	\$0	\$0
Small Tools		Lump Sum		\$27.50	0	\$0.00	\$0	\$0	\$0
Temporary Job Fence		Lump Sum		\$27.50	0	\$0.00	\$0	\$0	\$0
Office Trailers		Lump Sum		\$27.50	0	\$0.00	\$0	\$0	\$0
Storage Trailers		Lump Sum		\$27.50	0	\$0.00	\$0	\$0	\$0
		Lump Sum		\$27.50	0	\$0.00	\$0	\$0	\$0
		Lump Sum		\$27.50	0	\$0.00	\$0	\$0	\$0
		Lump Sum		\$27.50	0	\$0.00	\$0	\$0	\$0
		Lump Sum		\$27.50	0	\$0.00	\$0	\$0	\$0
		Lump Sum		\$27.50	0	\$0.00	\$0	\$0	\$0
		Lump Sum		\$27.50	0	\$0.00	\$0	\$0	\$0
		Hours		\$27.50	0	\$0.00	\$0	\$0	\$0
SYSTEM TOTALS							\$86,830	\$83,950	\$170,780

ATTACHMENT SECTION 8.5

INTERIM REVIEW COMMENTS AND RESPONSES

INTERIM REVIEW COMMENTS

UMCS FEASIBILITY STUDY

at

FORT GEORGE G. MEADE
Ft. Meade, Maryland

prepared by

ENTECH ENGINEERING, INC.
4 South Fourth Street
Reading, Pennsylvania 19603
610-373-6667
Entech #4130.07

April 24, 1996

Interim Review Comments and Responses

The following addresses the review comments (CENAB-EN-D Mechanical Comments - Kamphaus) for the UMCS Feasibility Study at Fort George G. Meade along with our responses.

Comment	Response
1. Page 1-1. Somewhere early in the report where it is first used the acronym "UMCS" should be defined. Thereafter it would be suitable to use the acronym only.	1. The acronym "UMCS" is defined at the beginning of Section 2.0 and will also be defined in the Executive Summary 1.0.
2. Ref: Section 5, Building by Building UMCS Analysis. The LCCS Summary sheets for each of the buildings use an economic life of 10 years. Indicate why this particular life was chosen and give the reference where it was obtained.	2. The 10 year economic life of a UMCS is as recommended in the "Energy Conservation Investment Program (ECIP) Guidance". DAIM-FDF-V letter dated 10 January 1994.
3. Ref: Section 5, Building by Building UMCS Analysis. Since this page format is used throughout the report, suggest that key items be blocked to highlight the items and an explanation of the significance of the item discussed.	3. In the Pre-final submission we will highlight and comment on the total cost savings, construction cost, and SIR for each building in the Building by Building UMCS Analysis.
4. Ref: Section 8 - Scope of Work. Paragraph 2.8. One sentence in the paragraph states that "In some cases differences in physical orientation may not allow buildings to be considered similar; it is anticipated that in most cases, physical orientation will not be a significant.". Please comment on the validity of this statement. Physical orientation of buildings play a significant part in the energy load on the building in the winter. Is the physical orientation of the building a minor item in the loads or is it to significant to be ignored?	4. The buildings that were considered similar were all multiple personal housing buildings. The energy savings from these buildings was small and building orientation would not have made a difference. Most of the buildings considered similar do have similar orientations, only the 4700 buildings had different orientations. Buildings of significant size were analyzed individually.
5. Ref: Section 1. This section is for an "Executive Summary". Please include the information required for this section in the submittal.	5. The Executive Summary will be included as part the Pre-final submission.

Interim Review Comments and Responses

The following addresses the review comments (CENAB-EN-D Electrical Comments -Vanden) for the UMCS Feasibility Study at Fort George G. Meade along with our responses.

Comment	Response
1. Concept.	1. Nothing to address.
2. Page 2-4 is missing.	2. Page 2-4 was sent to all parties that reviewed submission when this oversight was realized.
3. On page 6-3 distinguish between an "RCO" and an "RCU".	3. "RCO" is a typo and will be corrected to read "RCU". Pre-final note: Acronym RCU change to SFP (Smart Field Panel).
4. On page 6-3 modern technology allows for a Remote Control Unit (RCU) in each building connected to a Central Control Unit (CCU) by a Data Transmission Media (DTM) commonly referred to as a Distributed Process Control System which constitutes a greater expense. The other alternative is a Central Process Control System where all commands originate in the CCU. Justify use of a Central versus a Distributed System based on cost, benefits and useability of DTM.	4. This report is based on a distributed process system, which is what the scope of work requested. All control contractors now provide a distributed system as standard. The main reason for this is that in a Central System you have one computer controlling everything and if that computer goes down, everything goes down. In a distributed system if you lose the central computer, the system and individual buildings will still function. The DTM in a distributed system is used to transfer information only. There is no cost difference between a central system and a distributed system.
5. On Page 6-3 new UTP are to be routed in existing underground ductbanks. If heavy rains cause these to fill up with water, circuits could be short-circuited and communication between the CCU and RCU could be broken for several days. How often does Distributed System within buildings need to be upgraded with new information from the CCU? What is the Mean Time Before Failure (MTBF) and Mean Time to Repair (MTTR) of the DTM? If the situation develops where the MTBF is long and/or the MTTR is short this reviewer suggests going with the Central System. If the MTBF is short and the MTTR is long, I would go with the Distributed System. Further analysis is required to make this determination.	5. The CCU does not automatically update the individual RCU panel, updating is only performed when required. The RCU can operate indefinitely without contact with the CCU. The only information needed is outdoor air temperature which is received from other panel not the CCU. The scope of work for this project did not include analyzing a central versus a distributed process system.

Interim Review Comments and Responses

The following addresses the review comments (CENAB-EN-D Cost Engineering Comments - Blizzard) for the UMCS Feasibility Study at Fort George G. Meade along with our responses.

Comment	Response
<p>1. Projects in early stages of design prior to concept (30%) submittal, including pre-concept, studies, etc. do not have to be prepared in the Micro-Computer Aided Cost Engineering System Gold (MCACES). Future cost estimated will be prepared using MCACES. Ver. 5.30A, software package for use on IBM compatible micro-computers and supersedes the CACES system reference in TM 5-800-2 (appendices A, B, and F). A copy of the software and user's manual can be obtained from Cost Engineering branch at (410) 962-6723.</p>	<p>1. Information noted.</p>
<p>2. Provide date, name, address and telephone numbers for vendor/supplies quotes. Assumptions made in the development of the cost estimate must be provided via notes using the F-7 key at the Title or Detail level.</p>	<p>2. All costs were derived from the EMCS Cost Estimating Guidelines, CEHND-SP-90-244-ED-ME, as required in the scope of work. The total cost was checked against industry standard dollar per point costs and the costs were found to be reasonable. Pre-final note: Pre-final costs are based on the new draft UMCS cost estimator.</p>
<p>3. The cost estimate shown on the page after 5.2 shows a 7% percent sales Tax. Please use the 6% percent figure for Maryland.</p>	<p>3. The sales tax will be changed from 7% to 6% in the Pre-final submission.</p>
<p>4. Overhead should conform to TM 5-800-2, Chapter 11. Profit should be calculated through use of the Corps of Engineers Weighted Guidelines Method as shown in TM 5-800-2, Chapter 12, or use MCACES.</p>	<p>4. The overhead bond and profit figures are as required in the EMCS Cost Estimating Guidelines, CEHND-SP-90-244-ED-ME. The figures used appear to be in line with Chapter 11 and 12 in TM 5-800-2. The Methodology Section 2.0 will be updated to indicate source of overhead and profit costs.</p>
<p>5. When preparing labor rates please use the current Davis-Bacon rates for the area.</p>	<p>5. Current Davis-Bacon rates were used to calculate the labor cost correction for the area.</p>

Comment	Response												
<p>6. You show an employer's burden cost of 10% percent. Insurance and taxes on direct labor cost could range from 25% to 40% depending on location of work and discipline of trade. Please check.</p>	<p>6. The 10% employer's burden figure is a miss print, it was actually calculated based on 20%. In reviewing our 20% figure we did find it to be low. In the Pre-final submission we will use an employer's burden percentage number of 28%, which was derived as follows:</p> <table data-bbox="906 436 1469 640"> <tr> <td>Workers Compensation Insurance</td> <td>11.9%</td> </tr> <tr> <td>Unemployment taxes</td> <td>7.3%</td> </tr> <tr> <td>Social Security taxes</td> <td>7.65%</td> </tr> <tr> <td>Risk Insurance</td> <td>1.0%</td> </tr> <tr> <td>Total</td> <td>27.85%</td> </tr> <tr> <td>Use</td> <td>28%</td> </tr> </table> <p>These figure based on Baltimore, Maryland from 1996 Means Cost Data. Pre-final note: This item included in new UMCS cost estimator and not defined individually.</p>	Workers Compensation Insurance	11.9%	Unemployment taxes	7.3%	Social Security taxes	7.65%	Risk Insurance	1.0%	Total	27.85%	Use	28%
Workers Compensation Insurance	11.9%												
Unemployment taxes	7.3%												
Social Security taxes	7.65%												
Risk Insurance	1.0%												
Total	27.85%												
Use	28%												
<p>7. Written responses to comments provided by the Cost Engineering Branch review of the different stages of the estimate must be returned indicating actions taken on not taken with appropriate remakes.</p>	<p>7. Included herein.</p>												
<p>8. Please provide a diskette along with the hard copy of your estimate when you submit this project at the 30% percent stage. This will help expedite future reviews.</p>	<p>8. The project is a study only, no construction design will be performed.</p>												

Interim Review Comments and Responses

The following addresses the review comments (ANME-PWR-M Ft. Meade Comments - Johnson) for the UMCS Feasibility Study at Fort George G. Meade along with our responses.

Comment	Response
1. The UMCS Feasibility Study is very good overall. The display of information; format, tables, modeling and analysis seem very reasonable.	1.
2. The following comments are in reference to the review of the UMCS Feasibility Study for Fort Meade.	2.
2a. All pages should be numbered in a logical and sequential format. This should include tables and figures.	2a. The Pre-final submission will have all pages numbered by section.
2b. There are too many errors due to rounding off numbers. If the units are not consistent, calculations may be erroneous.	2b. In the Pre-final submission numbers, energy savings and construction costs, will be rounded to the nearest tenth rather than the nearest hundredth.
2c. The following are typographical errors found in the document: (1) Page 2-14, change "product" for "produce". (2) Throughout Section 5 and 6, The EMCS manual is listed as TM 5-815-9, instead of TM 5-815-2.	2c. These typographical errors will be corrected in the Pre-final submission.
2d. In pages 1-1 and 1-2, the statement regarding SIR should read "... SIR greater than..."	2d. This will be corrected in the Pre-final submission.
2e. The statement regarding $SIR > 1.25$ in page 1-2 is not supported by the calculations in Section 6. Current ECIP Guidance requires overall project and all discrete portions to have a $SIR > 1.25$.	2e. We chose a cut-off of a SIR of 1.0 in order to include more buildings in the project. We felt this was reasonable because of the minimal change in the overall project SIR between only buildings with an SIR greater than 1.25 and buildings with an SIR greater than 1.0. This is an item we intended to discuss at the interim review meeting, how to package the Final ECO and which buildings will be included. Pre-final note: Only buildings with an SIR greater than 1.25 are included in the recommended ECO.

Comment	Response
2f. Table 3.1 is missing occupancy information for the following buildings: 909, 2786, 2790, 9810.	2f. The occupancy information for buildings 909, 2786, 2790, and 9810 will be included in the Pre-final submission as follows: 909: Tue/Thus 8am-8pm, Fri 8am-7pm, Sat 12pm-7pm 2786: Mon-Fri 8am-7pm, Sat 8am-5pm 2790: Mon-Fri 9am-7pm, Sat 8am-5pm 9810: Mon-Fri 13 hrs/day, Sat-Sun 8 hrs/day
2g. Please clarify the meaning of Officers Quarter, Incl.	2g. The "Incl" should not be there. Building use should only read "Officers Quarters". This will be revised in the Pre-final submission.
2h. In Section 4, the incremental costs developed for the various fuels should also include incremental cost in \$/MBTU.	2h. A column will be added in the Pre-final submission to tables 4.1.1.1 and 4.2.1 to indicate the \$/MBTU for each line item.
2i. In the discussion of maintenance savings, the savings due to the existing system annual maintenance is ambiguous. The difference between the annual maintenance of the actual system and the annual maintenance of the proposed systems should be the savings (or costs) shown as annual recurring non-energy savings (or cost) in the Life Cycle Cost Analysis.	2i. The annual maintenance savings are not correct. The new UMCS annual maintenance costs need to be estimated and subtracted from the current EMCS maintenance costs for an accurate annual maintenance savings cost of the new UMCS over the existing EMCS.
2j. Section 5, where the individual buildings are analyzed should include the system information, as it was included in Section 3. This would help reduce the time spend looking from one section to the other.	2j. The existing building HVAC system descriptions from Section 3 will be added to each Building by Building Analysis in the Pre-final submission.
2k. Table 504-1 should have a column for lighting and an X in the appropriate cell.	2k. This will be corrected in the Pre-final submission.
2l. Table 504-2, 4552-2, 4553-2, and 4554-2 show four hours per year in labor savings. The other buildings with lighting control do not have this. Is there a reason for this?	2l. The 4 hours for labor savings on lighting is incorrect. There should be no effect on maintenance cost for lighting credit to the UMCS.
2m. In the analysis of building 2234, add to the proposal or the discussion how the day/night setback will be accomplished for the two-pipe fan coils.	2m. The day/night setback to the fan coils will be accomplished by cycling the pump to maintain a reduced space temperature. Connecting to each fan coil unit will be expensive due to the high number of fan coils and will not save that much more energy than simply cycling the pump. This explanation will be added under Section 2.6.1 General.

Comment	Response
<p>2n. Suggest evaluating day/night setback for the chapel, (building 4419).</p>	<p>2n. Day/night setback has been applied to the chapel. Scheduled start/stop is used for day/night setback savings in this case. The chapel is occupied infrequently compared to most spaces on the base. The scheduled start/stop strategy in the ESA program shuts the unit down completely in unoccupied, which provides maximum savings. When the new controls are applied the unit will actually cycle to maintain a reduced space temperature. In order to model this space and receive maximum savings the occupied hours were adjusted to include an estimated weekly average amount of hours the unit would need to run in the unoccupied cycle in order to maintain a reduced space temperature. This type of strategy was only used in spaces with a limited amount of occupied hours.</p>
<p>2o. Table 6530-1 indicates a reheat coil for AHU-1. Is this just during the heating season, or is it also used to compensate for dehumidification in the cooling season? If in cooling season, is there any way to eliminate-use so that the boiler won't have to operate during the summer?</p>	<p>2o. The reheat coil could be used during the heating and cooling season. The savings shown is for summer time operation only. The UMCS strategy resets the cooling supply temperature to minimize the amount of reheat. Reheat could not be totally eliminated in the summer without a detailed review, which is not included in the scope of work for this project.</p>
<p>2p. Building 8472 has a multizone air handler that operates on 100% OA. Suggest that not all zones require 100% OA, and those that do may not require it all the time. If nothing can be done with the UMCS, all least a recommendation could be made to serve the zone(s) requiring 100% OA with a dedicated air handler.</p>	<p>2p. The multizone air handling unit currently operates almost continually. With the UMCS the unit would be cycled based on an occupancy schedule. This will close the outdoor air damper in unoccupied. These savings are shown under the ventilation and recirculation strategy. I believe to recommend new HVAC equipment and system is beyond the scope of this project, but to answer the question: providing a dedicated air handler for spaces not requiring 100% outdoor air will probably not have a good payback. The reason for this is the areas not requiring 100% outdoor air probably are a small portion of the total air being supplied, hence minimal savings. The savings would not substantially offset installation cost.</p>

Comment	Response
2q. There is no envelope data provided for building 8481 in Section 8 as stated in Section 5.	2q. There is no envelope data because the building was not analyzed, only the three steam boilers. The Building by Building Analysis will be revised under the proposed section so that the second to last sentence reads "Refer to Attachment 8.2 G for Boiler equipment schedule".
2r. Some statement should be made about the status of the buildings on the existing system that were not included in the scope.	2r. It is not known to Entech as to why these buildings were not included. One statement we can make is that the existing EMCS will still be able to operated once the new UMCS is installed. This item can be better discussed at the interim review meeting.
2s. Section 6 should include a schematic showing the various system components.	2s. A system schematic will be prepared when the final total number of buildings to be part of the ECO is decided. The schematic will be included as part of the Pre-final submission.
2t. In page 6-2 the first two sentences should be revised to clarify that all buildings have been covered, some individually and some as "duplicate".	2t. The Pre-final submission will include this revision.
2u. In page 6-4 the General Cost is indicated as some percent of the fixed cost, yet the fixed cost or the percentage rate are not shown. Please add this information.	2u. The General Cost figure is the total of column "Percent of Fixed Cost" on the Systems Summary Economic Analysis worksheet. There is no percent number to be inserted here. The percent of fixed cost is from proportioning the general cost in Section 5.1 between each building based on the building's point total as compared to the UMCS point total. Note: the proportioning of these costs will need to be revised once the actual ECO UMCS point total is decided based on buildings to be included.
2v. In page 6-6 please indicate if "Labor Maintenance \$" and EMCS Maintenance \$" are a savings or a cost.	2v. Both of these maintenance dollars are considered savings. The labor maintenance dollars is the total from the ESA program and the EMCS maintenance dollars is the existing EMCS maintenance cost to be saved. Please note as stated in comment 2i above the EMCS maintenance costs will be revised.

Comment	Response
<p>2w. In DD Form 2289 the "Recurring Cost" column, "EMCS Maintenance \$" cannot be n/a (not applicable). There must be some annual maintenance cost for the system or it will not operate for long.</p>	<p>2w. Recurring cost for EMCS maintenance column will be revised in the Pre-final submission with data noted in comment 2i above. Pre-final note: This form deleted.</p>
<p>2x. In Section 8, the ESA calculation for building 1978 does not appear to take into consideration the inefficiencies of the boiler and steam distribution system when calculating the natural gas savings. Perhaps the efficiency is included in the ESA calculation before it is converted to cubic feet of gas, but there is not way to tell. Please correct or clarify here and wherever appropriate.</p>	<p>2x. The boiler efficiency is included in the calculation before it is converted to cubic feet of gas. The assumed boiler efficiencies for various types of boilers will be added to Section 2.0 in the Pre-final submission</p>
<p>2y. In Section 8, under Equipment Schedule for building 2234, the Fan Coils column has a number 30. Is this the number of fan coils or the aggregate HP of all the fan coil motors? Please clarify.</p>	<p>2y. The number 30 is the aggregate HP of all fan coil units. This same approach was used for each building with fan coil units.</p>
<p>2z. In Section 8, under Equipment Schedule for building 6530, the table shows a cooling capacity of 28 tons for AHU-1, but non for AHU-2. Section 5 indicated that this building has more than one DX coil and condensing unit. Please clarify.</p>	<p>2z. AHU-2 includes a 2 ton DX coil and condensing unit. There are (2) two DX coils and condensing units in Building 6530. Both units are included in the ESA computer calculation. The equipment schedule will be update to show a 2 ton unit with AHU-2.</p>
<p>3. The point of contact for this action is Ms. Daisy Correa (301) 677-9917.</p>	<p>3.</p>

Interim Review Comments and Responses

The following addresses the review comments (CENAB-EN-DM Mobile District Comments - Battaglia) for the UMCS Feasibility Study at Fort George G. Meade along with our responses.

Comment	Response
1. General: Overall, this is a good interim submittal. The field work, modeling, analysis, and reporting all look quite good.	1.
2. Pg 1-1, 1-2: Par 2 and Par 3 both should say "SIR greater than" rather than "SIR less than".	2. These typographical errors will be corrected in the Executive Summary in the Pre-final submission.
3. Pg 1-2: Par 3 statement regarding SIR > 1.25 is not supported by calculations in Section 6. This is an important point, because the current ECIP Guidance requires overall project and all discrete portions to have an SIR > 1.25. A LCCA Summary sheet should be prepared for a system comprised of all buildings with SIR > 1.25.	3. We chose a cut-off of a SIR of 1.0 in order to include more buildings in the project. We felt this was reasonable because of the minimal change in the overall project SIR between only buildings with an SIR greater than 1.25 and buildings with an SIR greater than 1.0. This is an item we intended to discuss at the interim review meeting, how to package the Final ECO and which buildings will be included. Pre-final note: Only buildings with an SIR greater than 1.25 are included in the recommended ECO.
4. General: All pages should be numbered. Please use the system you have started, with the section number, a hyphen, and the page number; but include all the tables and figures.	4. The Pre-final submittal will have all pages numbered by Section.
5. Table 2.6.1: There are Xs under several of the control strategies for two-pipe fan coil units; but in the analysis of individual buildings this does not appear to be supported. I wouldn't think some of these would be cost effective for fan coils. Please review and correct as necessary.	5. In order to utilize the first four strategies for fan coil units, each fan coil would have to be started /stopped individually or in banks of units by the UMCS. The amount of fan coils in buildings that utilize fan coils for conditioning is great and the cost to connect to the fan coils will not be offset by the energy savings. Also the fan coils are the main source of heat for the building and could not be simply shutdown in the unoccupied cycle (schedule start/stop, optimum start/stop strategies). The motor load for even the largest building is too small to effectively apply demand limiting and duty cycling. This explanation will be added to page 2-8 in the Pre-final submission to further explain why only day/night setback strategy will be used for fan coils.

Comment	Response
6. Pg 2-11: Par 2.6.6; The last part of the last sentence is a bit confusing. Maybe something about the cooling season was left out. Please check and correct as necessary.	6. A reference to cooling needs to be made to the last sentence to avoid confusion. This will be corrected in the Pre-final submission.
7. Pg 2-14: Par 2.6.14; Correct spelling of "produce".	7. This will be corrected in the Pre-final submission.
8. Sec 3: The building descriptions of Section 3 are very good; however, it would be desirable to have the system information also in Section 5 where the individual buildings are analyzed. As it is set up, one has to keep flipping from Section 5 to Section 3 to see what type heating or cooling system is used.	8. The existing building HVAC system description from Section 3 will be added to each Building by Building Analysis in the Pre-final submission.
9. Sec 3: a. Please complete building occupancy info for the following buildings: 909, 2786, 2790, 9810. b. Please clarify meaning of "Officers Quarter, Incl" (Including? What?) For Buildings 4703 - 4721.	9. a. The occupancy information for buildings 909, 2786, 2790, and 9810 will be included in the Pre-final submission as follows: 909: Tue/Thus 8am-8pm, Fri 8am-7pm, Sat 12pm-7pm 2786: Mon-Fri 8am-7pm, Sat 8am-5pm 2790: Mon-Fri 9am-7pm, Sat 8am-5pm 9810: Mon-Fri 13 hrs/day, Sat-Sun 8 hrs/day b. The "Incl" should not be there. Building use should only read "Officers Quarters". This will be revised in the Pre-final submission.
10. Sec 4: Where the incremental cost are developed for the various fuel, please include the incremental cost in \$/MBTU.	10. A column will be added in the Pre-final submission to tables 4.1.1.1 and 4.2.1 to indicate the \$/MBTU for each line item.
11. Pg 5-1: Par 5.1, Point List: The EMCS manual is listed as TM 5-815-9. This should be TM 5-815-2. Please correct here and at other places in text where this TM was referenced.	11. These typographical errors will be corrected in the Pre-final submission.
12. Sec 5: Between pg 5-2 and pg 5-3 there is a Construction Cost Estimate for Central Systems and Equipment. It is not mentioned in the text; is it out of order? Please check and make necessary corrections.	12. The construction cost estimate is referred to in the second paragraph of the construction cost section of page 5-2. The reference does get lost in the wording, this will be corrected in the Pre-final submission.

Comment	Response
<p>13. Pg 5-3: Re: discussion of maintenance savings: The savings of one 4-hour visit per system seems reasonable. The second savings is not very well explained. It looks as if you are trying to take credit as a savings for all of the existing system annual maintenance. The annual maintenance requirements for the existing system can be documented. The annual maintenance requirements for the proposed system can be estimated. The difference is the savings (or cost) that should be shown as annual recurring non-energy savings or cost in the Life Cycle Cost Analysis.</p>	<p>13. The annual maintenance savings are not correct. The new UMCS annual maintenance costs need to be estimated and subtracted from the current EMCS maintenance costs for an accurate annual maintenance savings cost of the new UMCS over the existing EMCS.</p>
<p>14. Pg 5-3: Is \$12,000 the correct figure for the Annual Honeywell Service Contract on the existing system? It looks low to me.</p>	<p>14. This was the cost provided to us by the DPW at Fort Meade.</p>
<p>15. Sec 5: The page numbering for each building in Section 5 begins with page 5-1. This is confusing. Please refer to Comment 4, above.</p>	<p>15. All pages in Section 5 will be numbered consecutively, 5-x, including tables and LCCA output.</p>
<p>16. General: The rounding errors seem to be excessive. It looks as if the calculations and reporting are not consistent in some cases. The incremental cost shown for fuels should be consistently shown as \$9.38/mmBtu for electricity, \$3.85/mmBtu for gas, etc. The dollar savings for fuels or labor should be reported to the nearest ten dollars. I realize that the calculations are not the precise, but rounding off to hundreds of dollars causes some confusion.</p>	<p>16. In the Pre-final submission number, energy savings, and construction costs, will be rounded to the nearest tenth rather than the nearest hundredth.</p>
<p>17. Sec 5: Regarding construction cost estimated for individual buildings: a. Suggest adding the description, "Total Points" to the line where the points are summed. b. Since this is not my area of expertise, I will have to qualify this comment, and ask you check with the MCX for UMCS at the Engineering Support Center, Huntsville. Phone (205) 895-1749 or 895-1739. Ask for Chuck Holland or Will White. The General System Costs of \$319 per point seems high to me. Please verify.</p>	<p>17. a. This change will be made to the building cost estimated in the Pre-final submission. b. These costs were derived from the EMCS Cost Estimating Guidelines, CEHND-SP-90-224-ED-ME. These costs appeared excessive to us also. The overall cost per point is about 1,200 \$/point, which is the average cost per point for a new UMCS. We verified this cost with the existing EMCS manufacturer's representative and other manufacturer's. Pre-final note: Cost based on the new draft UMCS cost estimator.</p>
<p>18. Table 504-1: Add column for lighting and an X in the appropriate cell.</p>	<p>18. This will be corrected in the Pre-final submission.</p>

Comment	Response
<p>19. Table 504-2: Four hours per year are shown as labor savings for lighting. This is not shown for all buildings that have lighting control; is there something special building Bldg 504? I would not expect the UMCS to have any effect on maintenance cost for lighting.</p>	<p>19. The 4 hours for labor savings on lighting is incorrect. There should be no effect on maintenance cost for lighting credit to the UMCS.</p>
<p>20. Sec 5 B/2234: Add to the Proposal or the Discussion how the day/night setback will be accomplished for the two-pipe coils.</p>	<p>20. The day/night setback to the fan coils will be accomplished by cycling the pump to maintain a reduced space temperature. Connecting to each fan coil unit will be expensive due to the high number of fan coils and will not save that much more energy than simply cycling the pump. This explanation will be added under Section 2.6.1 General.</p>
<p>21. Sec 5, B/4419: Suggest evaluating day/night setback for the chapel.</p>	<p>21. Day/night setback has been applied to the chapel. Scheduled start/stop is used for day/night setback savings in this case. The chapel is occupied infrequently compared to most spaces on the base. The scheduled start/stop strategy in the ESA program shuts the unit down completely in unoccupied, which provides maximum savings. When the new controls are applied the unit will actually cycle to maintain a reduced space temperature. In order to model this space and receive maximum savings the occupied hours were adjusted to include an estimated weekly average amount of hours the unit would need to run in the unoccupied cycle in order to maintain a reduced space temperature. This type of strategy was only used in spaces with a limited amount of occupied hours.</p>
<p>22. Sec 5, B6530: Table 6530-1 indicates a reheat coil for AHU-1. Is this just used during the heating season, or is it (also) used to compensate for overcooling (dehumidification) in the cooling season? If in cooling season, is there any way to eliminate use so boiler won't have to operate in the summer?</p>	<p>22. The reheat coil could be used during the heating and cooling season. The savings shown is for summer time operation only. The UMCS strategy resets the cooling supply temperature to minimize the amount of reheat. Reheat could not be totally eliminated in the summer without a detailed review, which is not included in the scope of work for this project.</p>

Comment	Response
<p>23. Sec 5, B8472: This building has one multizone air handler that operates on 100% OA. Suggest that not all zones require 100% OA, and those that do may not require it all the time. If nothing can be done with the UMCS, at least a recommendation could be made to serve the zone(s) requiring 100% OA with a dedicated air handler.</p>	<p>23. The multizone air handling unit currently operates almost continually. With the UMCS the unit would be cycled based on an occupancy schedule. This will close the outdoor air damper in unoccupied. These savings are shown under the ventilation and recirculation strategy. I believe to recommend new HVAC equipment and system is beyond the scope of this project, but to answer the question: providing a dedicated air handler for spaces not requiring 100% outdoor air will probably not have a good payback. The reason for this is the areas not requiring 100% outdoor air probably are a small portion of the total air being supplied, hence minimal savings. The savings would not substantially offset installation cost.</p>
<p>24. Sec 5, B8481: In the proposal, delete the word, "envelope" because there is no envelope data provided for this building in Section 8.</p>	<p>24. There is no envelope data because the building was not analyzed, only the three steam boilers. The Building by Building Analysis will be revised under the proposed section so that the second to last sentence reads "Refer to Attachment 8.2 G for Boiler equipment schedule".</p>
<p>25. Pg 6-2: Some statement should be made about the status of the 12 buildings on the existing system that were not included in the scope.</p>	<p>25. It is not known to Entech as to why these buildings were not included. One statement we can make is that the existing EMCS will still be able to operated once the new UMCS is installed. This item can be better discussed at the interim review meeting.</p>
<p>26. Pg 6-2: Proposed: The first two sentences should be revised to clarify that all buildings have been covered, some individually, and some as "duplicates".</p>	<p>26. The first paragraph will be revised to reflect this change in the Pre-final submission.</p>
<p>27. Pg 6-3: Again, I defer to Huntsville's expertise, but I believe that the preferred (actually, the mandated) DTM is now fiber optics. Fort Meade would have to obtain a waiver to use wire line. Please verify.</p>	<p>27. We will review with Fort Meade DPW personnel, if fiber optics is or will be available on the present or near future.</p>
<p>28. Sec 6: Include a schematic showing the various system components.</p>	<p>28. A system schematic will be prepared when the final total number of buildings to be part of the ECO is decided. The schematic will be included as part of the Pre-final submission.</p>

Comment	Response
<p>29. Pg 6-4: The General Cost is indicated as some percent of the fixed cost; however, neither the fixed cost nor the percentage rate are shown. Please add.</p>	<p>29. The General Cost figure is the total of column "Percent of Fixed Cost" on the Systems Summary Economic Analysis worksheet. There is no percent number to be inserted here. The percent of fixed cost is from proportioning the general cost in Section 5.1 between each building based on the building's point total as compared to the UMCS point total. Note: the proportioning of these costs will need to be revised once the actual ECO UMCS point total is decided based on buildings to be included.</p>
<p>30. Pg 6-5: Regarding maintenance savings: See comment 13, above.</p>	<p>30. Refer to the response to Comment 13, above.</p>
<p>31. Pg 6-6: For "Labor Maintenance \$" and "EMCS Maintenance \$", indicate if savings or cost.</p>	<p>31. Both of these maintenance dollars are considered savings. The labor maintenance dollars is the total from the ESA program and the EMCS maintenance dollars is the existing EMCS maintenance cost to be saved. Please note as stated in comment 2i above the EMCS maintenance costs will be revised.</p>
<p>32. DD Form 2289: The "Recurring Cost" column, "EMCS Maintenance" cannot be n/a (not applicable). There must be some annual maintenance cost for the system or it will not operate for long.</p>	<p>32. Recurring cost for EMCS maintenance column will be revised in the Pre-final submission with data noted in comment 13, above.</p>
<p>33. Table 6-1: Excellent Summary.</p>	<p>33.</p>
<p>34. Sec 8, B/1978: ESA Calculation, pg 3: The natural gas savings shown for the steam unit heaters do not appear to take into account the inefficiencies of the boiler and steam distribution system. I noticed in several of the individual building analyses in Section 5, that an overall efficiency of .65 had been assumed for the oil-fired boilers and distribution systems. Perhaps the efficiency is included in the ESA calculation before it is converted to cubic feet of gas; but there's no way to tell. Please correct or clarify here and wherever appropriate. This could perhaps be covered by some additional discussion in Section 2, ie, stating assumed efficiencies for various cases.</p>	<p>34. The boiler efficiency is included in the calculation before it is converted to cubic feet of gas. The assumed boiler efficiencies for various types of boilers will be added to Section 2.0 in the Pre-final submission.</p>

Comment	Response
<p>35. Sec 8, B2234: Equipment Schedule: Under column 4, Fan Coils, is the number 30, the number of fan coils, or the aggregated HP of all the fan coil motors, or what? Please clarify.</p>	<p>35. The number 30 is the aggregate HP of all fan coil units. This same approach was used for each building with fan coil units.</p>
<p>36. Sec 8, B/6530: Equipment Schedule: Section 5 indicates that this building has more than on DX coil and condensing unit. This table shows a cooling capacity of 28 tons for AHU-1, but none for AHU-2. Please clarify.</p>	<p>36. AHU-2 includes a 2 ton DX coil and condensing unit. There are (2) two DX coils and condensing units in Building 6530. Both units are included in the ESA computer calculation. The equipment schedule ill be update to show a 2 ton unit with AHU-2.</p>

Interim Review Comments and Responses

The following addresses the review comments (CEHNC-ED-ME-T, UMCS-MCX Engineering and support Center Comments - White) for the UMCS Feasibility Study at Fort George G. Meade along with our responses.

Comment	Response
1. General: This appears to be the start of a good analysis. The contractor has demonstrated knowledge of energy savings analysis techniques and the documentation indicated he performed a detailed investigation of the installation. There are, however, a few clarifications and corrections needed. (I have attempted to not duplicate the comments made by Mr. Batteglia of the Mobile District). Please address the following questions and concerns.	1.
2. Page 1-1. In the current climate of downsizing and shrinking funds, ECIP and FEMP projects need to have an overall SIR of greater than 2.5 (maybe higher) to complete. Suggest you focus on the bigger fish and offer a package with a more attractive payback.	2. This is an item we intend to discuss at the interim review meeting as to what amount of buildings will be in the recommended package.
3. Page 2-4, third line. Put a comma after "after".	3. This item will be correct in the Pre-final submission.
4. Table 2.6.1. Don't see how ventilation/recirculation applies to a direct fired furnace.	4. I believe the direct fired furnace system encompasses different types of equipment from a residential gas furnace to a large direct fired gas air rotation unit. The air rotation units can be provided with the capability to handle outdoor air. A direct fired roof top 100% outdoor air, air handling unit would also be covered under this type of system. In the EMCS manual, TM 5-815-2, the Heating and ventilating system and direct fired furnace system point lists and schematic are very similar. The main difference between the two is the heating/ventilation unit schematic shows a heating coil and the direct fired furnace schematic shows a furnace heat exchanger.
5. Page 2-8. We're sure Entech wishes to exercise prudent engineering practices in ALL instances.	5.
6. Pages 2-9 through 2-15. Good description of the control strategies.	6.

Comment	Response
7. Page 2-11, para 2.6.7. Should expand this and describe how the return air temperature is included in the calculation. Also, with DDC the supply air set point can become the mixed air set point to achieve free cooling.	7. The economizer description will be expanded to include return air temperature in the pre-final submission.
8. Page 2-12, para 2.6.9. Correct the typo on "rest" in the first line.	8. This item will be corrected on the pre-final submission.
9. Page 2-21. The description of the common criteria fits for the example of page 2-25 but not the study. Coordinate the example with the actual inputs.	9. The example will be updated in the Pre-final submission to reflect the updated LCCID version and how it applies to this study.
10. Table 2.9.1. Is too blurry.	10. A readable table 2.9.1 will be included on the Pre-final submission.
11. Page 5-1, last 2 lines. Disagree that the space temperature and the return air temperature are equal. You need a return air temperature sensor to properly evaluate the conditions for implementing the economizer cycle.	11. The strategy here was to reduce construction costs. The return air and space temperature are not exactly equal but should be close enough to being the same for the non-critical level of the majority of the systems at Fort Meade. The only building that may require a critical level of control is Building 2490 - Laboratory, except that the building requires 100% outdoor and return air is not required. The explanation on page 5-1 will be expanded on the Pre-final submission to include the above information.
12. Section 5, building 370. This comment applies to many other buildings as well. The paragraph entitled "Existing" is confusing as the point counts don't add up. Also you list four start-stop points but say in the next sentence that these points are "monitoring only". Does the existing Honeywell system start and stop any equipment? If not, apply the scheduled start-stop strategy to this equipment. If the existing system has (or had) the capability to start-stop and it's not being utilized, consider claiming that savings with a new system. The existing Honeywell is approaching 20 years old and may have lost a few electrons here and there.	12. The statement "These points are monitoring only points" means that the existing Honeywell system is no longer capable of controlling the start/stop points and now only monitors whether the equipment is operating or not. We do not know how the points were originally controlled. The start/stop strategy was applied to all equipment that was not the only source of heat to building spaces, as stated on page 2-8. The start/stop strategy shuts-down the equipment totally in unoccupied. For spaces that need to maintain a setback temperature, the day/night setback strategy was used which allows the unit to cycle on and off. The explanation on page 2-8 will be expanded in the Pre-final submission to better explain the reasons for using the start/stop and day/night setback strategies.

Comment	Response
13. Section 5, building 370 and all the rest. The LCCA summary sheets are obsolete. The new discount factors for fuel and annual recurring savings should be used. Use NISTIR 85-3273-10 dated October 1995.	13. The LCCA sheets were updated in January with the latest information received from the Corps of Engineers. We do have a proposed version that has figures updated as of October 1995. We would like to review this with you at the interim review meeting.
14. General. Suggest using a current sensing relay to monitor status of the pumps instead of differential pressure switches. May save a few dollars.	14. Yes, the current sensing relay will be less expensive than the differential pressure switch, but is probably not worth changing since it will not impact the SIR.
15. Section 5, building 375 and many more. Please expand on your discussion of the lighting control strategy. What are the assumptions that lead to the savings? In many buildings this is the lion share of the claimed savings and an unrealistic amount. I don't believe the system can turn enough lights off to affect so much savings unless these buildings are left with their lights on after hours most of the time. With the command emphasis on the Army Energy Awareness Program that is unlikely. Please provide some sample calculations.	15. We only applied the lighting control strategy to non-supervised buildings. The existing kW was arrived at by using 1.5-2.0 watts per square foot times the building or applicable square footage. The amount of lights that would be off versus existing ranged from 20 to 40 hours per week depending on the building usage.
16. Section 5, building 2490. Clarify how you will achieve ventilation/recirculation savings with systems that do not recirculate. These are 100% outside air units. If you can close the OA damper with no other source for air, why not just turn the fan off?	16. The strategy is to simply shutdown the units. AHU-1 would be shut-down in unoccupied and AHU-2 would have a reduce air flow in unoccupied. Neither unit would have any recirculation.
17. Section 5, building 2786. Again, this related to my previous comment #12. Why not consider schedule start/stop here? Does the day/night setback strategy cycle the fans off and on to maintain the new set point or do the fans run while the control valve is modulated? If the fans are cycled off and on then it's a wash. But otherwise, it's best to implement the strategy of scheduling the fans and pumps off at a certain time and then allowing them to reenergize to maintain some minimum default temperature.	17. The day/night strategy applied in the study assumed the fans would be cycled on and off to maintain a reduced space temperature. It is our option that in cases where an air handler (for example) is the only source of heat, the application is actually a combination of the scheduled start/stop, optimum start/stop, and day/night setback. In this case we only used that day/night setback strategy so as not to duplicate savings.
18. Section 5, building 3000, table 3000-2. Appears to be some inconsistencies between the strategies selected and the savings shown in the table. Where does the natural gas savings come from under scheduled start/stop? Why are there no savings listed under economizer?	18. The economizer strategy was inadvertently marked on table 3000-1. The ESA program must be rerun and table 3000-2 updated. The day/night setback and start/stop strategies were incorrectly run for this building.

Comment	Response
<p>19. Section 8.2E, building 4554. This applies to all the buildings that were analyzed with DOE-2. It's difficult to track the energy use of all the alternatives. This report needs a summary sheet that consolidates the final calculated yearly energy use of the baseline (existing conditions) and all the alternatives. Specifically on this building, it appears there is virtually no difference between the energy use between ventilation/night setback and ventilation/night setback/economizer. This result essentially says the economizer strategy has no savings whatsoever. This is unexpected. Please clarify.</p>	<p>19. A DOE savings summary sheet will be added to each building in Section 8.2 which utilized DOE for energy savings calculations. The DOE input and output for building 4554 will be checked and recalculated. We had some difficulties with the DOE program and economizer savings.</p>
<p>20. Section 5, building 4215. It is unclear how many fan coil units are involved here. You show five Dots. Again, suggest implementing the start stop strategy if control is there. This confusion seems to appear throughout the study. It's difficult to determine how many pieces of equipment are involved.</p>	<p>20. In order to utilize the first four strategies for fan coil units, each fan coil would have to be started /stopped individually or in banks of units by the UMCS. The amount of fan coils in buildings that utilize fan coils for conditioning is great and the cost to connect to the fan coils will not be offset by the energy savings. Also the fan coils are the main source of heat for the building and could not be simply shutdown in the unoccupied cycle (schedule start/stop, optimum start/stop strategies). The motor load for even the largest building is too small to effectively apply demand limiting and duty cycling. This explanation will be added to page 2-8 in the Pre-final submission to further explain why only day/night setback strategy will be used for fan coils.</p>
<p>21. Section 8.3. The EMCS cost estimating guideline was not reproduced in its entirety. Every other page is missing.</p>	<p>21. The missing page in Section 8.3 will be included in the Pre-final submission.</p>

Interim Review Comments and Responses

The following addresses the review comments (ED-ES, UMCS-MCX Estimating Comments - Alford) for the UMCS Feasibility Study at Fort George G. Meade along with our responses.

Comment	Response
<p>1. Central System & Equipment Cost Estimate - The material costs for the Central System and Equipment, including System Equipment Hardware, Command Software, Application Programs, RCU Hardware, MUX Hardware, RCU Test Set, RCU Portable Tester, and Testing appear excessive. Verify.</p>	<p>1. These costs were derived from the EMCS Cost Estimating Guidelines, CEHND-SP-90-224-ED-ME. These costs appeared excessive to us also. The overall cost per point is about 1,200 \$/point, which is the average cost per point for a new UMCS. We verified this cost with the existing EMCS manufacturer's representative and other manufacturer's. Pre-final note: Cost based on new draft UMCS cost estimator.</p>
<p>2. All Building Construction Cost Estimating - As noted on page 5-2, paragraph 5.1, the General Systems Costs (Central System and Equipment) are distributed among the buildings based on the building point total as compared to the total system point count and the total system point count is 2,464. However, the material cost of \$319 per point and the labor cost of \$165 per point does not correlate with the total material cost of \$1,182,300 and labor cost of \$618,800 for the General Systems cost with the given point total. Using the 2,464 point total and the above material and labor costs, the material cost equated to approximately \$480 and the labor cost equates to approximately \$251 per point. Verify which is correct and change the estimates appropriately.</p>	<p>2. The costs per point for the general system shown in each building's construction cost estimate do not include overhead, profit and bond and contingency. If these were included, they would be duplicated. The Control Systems and Equipment Cost Summary will be updated in the Pre-final submission to show this more clearly and separate out the DTM costs. The cost per point must be corrected to reflect the final total point count.</p>
<p>3. All Building Construction Cost Estimates - The data transmission medium costs, depicted on a per point cost, cannot be verified. Provide backup and/or rationale for determining this cost and the amount of DTM estimated to be used per point.</p>	<p>3. The Data Transmission Medium (DTM) costs are shown on the Central System and Equipment Cost Summary and as stated above will separate out to show clearly how the cost per points were derived in the Pre-final submission.</p>
<p>4. Page 6-4,- For all buildings, the General Systems cost is listed a \$1,628,000 and on the Central System & Equipment Cost Estimate, the General Systems cost is \$1,801,100. Verify which is correct and change the table appropriately.</p>	<p>4. These figures will be corrected when the final UMCS total point count is finalized, depending on the number of buildings to be part of the recommended ECO.</p>

Comment	Response
<p>5. Bldg 370 Life Cycle Cost Analysis - The energy savings for electricity consumption of 165 mBtu/yr appears incorrect. The value should be 25 mBtu/yr. The total energy savings should total to 388 mBtu/yr. The total new discounted savings should total to \$54,675 and the savings-to-investment ratio should be 1.23. Verify all energy savings used in the life cycle cost analyses of all buildings.</p>	<p>5. The Life Cycle Cost Analysis is incorrect for building 370, all buildings will be checked and corrected as required.</p>
<p>6. System Summary Economic Analysis Worksheet - The First Cost (UMCS Hardware, Modifications, DTM Installation, and Percentage of Fixed Costs) do not correlate with the costs obtained in the Construction Cost Estimate for all buildings. Verify which is correct and change the worksheet appropriately.</p>	<p>6. Each of the first costs was totaled separately for each building and the overhead, profit and bond, and contingency percentages applied to each individual cost than imputed into the Systems Summary Economic Analysis Worksheet. The building total figures do correlate with each individual total building cost shown in Section 5.0.</p>

ATTACHMENT SECTION 8.6
LIGHTING CONTROL SWITCH
CATALOG INFORMATION

SENTRY SWITCH

SS SERIES

DESCRIPTION

The **Sentry Switch** is a unique UL listed replacement device for a 120V or 277V, standard or 3-way wall switch, which provides the capability of centrally "sweeping off" overhead lighting automatically, then allowing local override at every switch location.

The installed switches are centrally "swept off" by means of momentarily interrupting the supply voltage at the lighting circuit breaker panel to the controlled lighting circuits.

Sentry Switches, installed in place of the standard wall switches, are designed to sense this momentary interruption (5 seconds) of their power source, then physically unlatch, dropping to the OFF position.

When in the OFF position, the switch toggles illuminate, allowing them to be easily identified by anyone requiring after hours override of their own lights. This feature allows unnecessary lighting to be turned off after-hours, and turned off ahead of, and behind, janitorial and maintenance crews.

Different schedules can be programmed for weekend occupancy. The **Sentry Switch** system used in place of conventional wall switches will allow the building operator to control after-hours lighting automatically.

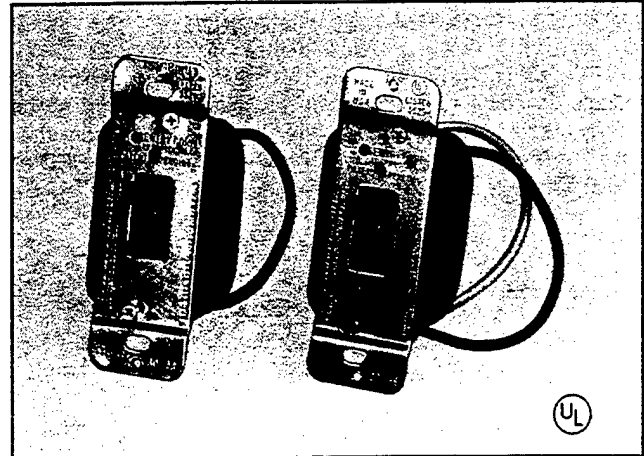

Tenant comfort and acceptance is assured by having override available at any time, from any switch, for only that particular area. Substantial power savings will be realized, not only from containing after-hours use, but also because lighting will not be turned on the following morning until that particular office or area is physically occupied.

OPERATION

Although controlling the **Sentry Switch** is very simple, the variations of implementation can be quite diverse.

A contactor or low voltage relay panel will be installed adjacent to the lighting circuit breaker panel to provide the 5-second interruption to the lighting circuits. This panel will be interfaced to the BAS system to provide the automatic lighting control "sweeps." A short off sweep (less than 3 seconds), allows advance warning that the lights will be turned off.

Normally closed contactors are recommended for these panels as they provide a mechanical failsafe to the ON position.

The **SS 20277 Sentry Switch** replaces a standard 120V or 277V toggle wall switch with a minimum 1 ampere and maximum 20 ampere load.

The low current version, **SS 05277** must be used on loads less than 1 ampere (approx 6-40 watt lamps), but has a maximum capacity of 5 amperes (approx 24-40 watt lamps).

The **SS 23277** is a 3-way emulation version of the **Sentry Switch**. Although functionally equivalent to a 3-way switch, there is an operational compromise. The lights cannot be off with both light switches in the UP position. When switch #1 is in the UP position, manually moving switch #2 to the UP position will result in the lights coming back on within 5 seconds. The operator must then move switch #2 back down to turn the lights off.

SENTRY SWITCH

SS SERIES

INSTALLATION / WIRING / CHECKOUT

INSTALLATION: Sentry Switches are direct mechanical replacements for standard wall toggle switches and all utilize standard single and multi-ganged wall boxes, plaster rings and switch plates. Sentry Switches are spring-loaded to the OFF position. They are mechanically held in the ON position. Be sure the mounting flange marked TOP is UP and that the switch springs to the DOWN position. On 3-way switches, be sure the RED and YELLOW wires are crossed RED to YELLOW and YELLOW to RED in conventional traveller manner.

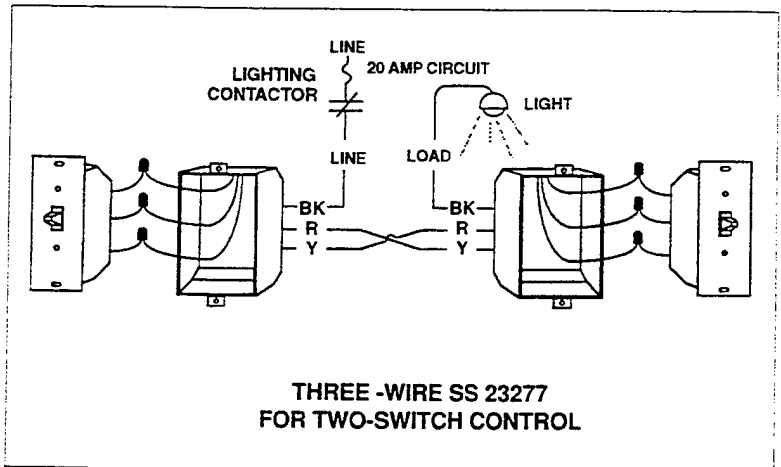
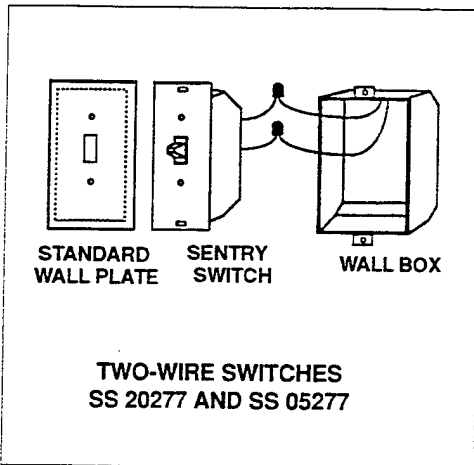
**WIRING:**

The 2-wire switches (SS 20277 and SS 05277) have conventional SPST switching contacts and are not polarity sensitive.

The 3-wire SS 23277 is a standard SPDT contact arrangement, BLACK connects to LINE or LOAD, RED and YELLOW are connected as "cross-over" travellers in the conventional manner RED to YELLOW - YELLOW to RED.

CHECKOUT:

All Sentry Switches are mechanically held on. When they release, you can hear the mechanism trip. Any time the power to any properly loaded Sentry Switch is interrupted for more than five seconds, the switch will trip. To check a Sentry Switch, observe the switch in the OFF position. The lever should be illuminated. Turn the switch ON and make sure the appropriate lights turn ON. Turn off the power to the circuit feeding the Sentry Switch. After five seconds you will hear the mechanism trip and the switch will move to the OFF position. If the Sentry Switch fails to trip OFF, check the light circuit to make sure at least a 1 amp load is connected. If the load is less than 1 amp (approx 6 x 40 watt lamps), you will need to replace the standard Sentry Switch with a low current model. If the load is correct, replace the Sentry Switch.

For 3-way switch applications, the minimum load allowed will be 1 amp. The individual 3-way switches are checked as above.

NOTE: Unlike conventional 3-way switches, it is impossible to have the lights OFF with both 3-way Sentry Switches in the UP position. If the lights are ON and you attempt to turn them OFF by moving a switch to the UP position, the lights will turn OFF and within five seconds the switch you are not operating will trip OFF turning the lights back on. This is normal. It is then necessary to turn the switch you are operating back down to the OFF position. The normal OFF position for both 3-way switches is down. If the lights are OFF and either 3-way Sentry Switch is in the UP position, the switch is wired wrong and must be rewired.

ORDERING INFORMATION

SS 20277	Sentry Switch for 1 amp to 20 amp load (minimum 6-40 watt lamps) 120V or 277V applications
SS 05277	Sentry Switch for loads 1 amp or less (rated for up to 24 lamps) 120V or 277V applications. (DO NOT EXCEED the maximum 5A current rating.)
SS 23277	Sentry Switch for 3-way switches, 120V or 277V applications.

SENTRY SWITCH APPLICATIONS GUIDE

This brief guide is provided to introduce the SENTRY SWITCH lighting control system to the new user, and to assist the lighting design professional in applying this innovative control strategy in retro-fit of existing structures and energy efficient new building designs.

OVERVIEW OF OPERATION.

The SENTRY SWITCH is a centrally controlled wall light switch, designed to efficiently replace conventional toggle or "decorator" light switches in commercial lighting control applications.

This elegantly simple lighting control system requires no additional control wiring, and is applied and installed exactly the same way as conventional standard or three-way wall switches. The only other items required to fully automate a SENTRY SWITCH lighting control system are standard lighting control panels, and an Electronic Time Clock or building E.M.S.

SENTRY SWITCHES operate by detecting an intentional power interruption of a specific duration. Simply remove power for 6 seconds and they will automatically "sweep" off!

If a power interruption or programmed "sweep" of less than 2 seconds in duration is detected by SENTRY SWITCHES, lighting will blink OFF momentarily but SENTRY SWITCHES that were ON, will remain latched in the ON position.

This design function serves a dual purpose. If there is a failure in your utility's primary power source, their automatic switching equipment will typically transfer to an alternate source within 1.5 seconds, 85% of the time. SENTRY SWITCHES will ride through most of these momentary interruptions, known as transfer outages, without unlatching. In fact programmed "sweeps" of 1.5 seconds or less are often scheduled by an operator, as warning of an impending OFF sweep.

When a sweep or power interruption of greater than 5.0 seconds is detected by a SENTRY SWITCH, it will respond by snapping to the OFF position.

As the switches physically snap to the OFF position, an integral neon indicator light in each switch illuminates to provide ready access for convenient over-ride. A user need only glance at the illuminated switch to see how to immediately restore their own lights.

TYPICAL SEQUENCE OF OPERATION

The following diagram illustrates the timing relationship between lighting control contactors, SENTRY SWITCHES and the over-head lighting in a typical installation.

Figure 1.

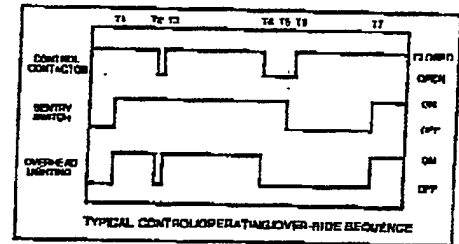

DESCRIPTION OF OPERATION

- T1 SENTRY SWITCH IS MANUALLY TURNED ON
 - T2 LIGHTING CONTACTOR OPENS INITIATING WARNING SWEEP LIGHTS BLINK OFF TO WARN OF IMPENDING SWEEP
 - T3 LIGHTING CONTACTOR CLOSES AFTER 1 SECOND LIGHTS TURN BACK ON
 - T4 LIGHTING CONTACTOR OPENS INITIATING "OFF" SWEEP LIGHTS TURN OFF
 - T5 SENTRY SWITCH UNLATCHES, SNAPS TO "OFF" POSITION
 - T6 LIGHTING CONTACTOR CLOSES AFTER 6 SECONDS NEON INDICATOR IN SENTRY SWITCH ILLUMINATES
 - T7 SENTRY SWITCH MANUALLY OVER-RIDDEN AT ANY TIME
- SENTRY SWITCH WILL BE AUTOMATICALLY SWEEPED BACK OFF WITH THE NEXT PROGRAMMED SWEEP.

Control strategies vary to individual requirements, but typically the first daily sweep occurs at about 6:00 PM and is repeated each hour until 2:00 AM. Additional weekend sweeps are often scheduled at 12:00 PM and 4:00 PM. Warning blinks which optionally precede the actual "OFF" sweeps by 30 seconds, are sometimes useful in applications where emergency lighting is minimal or occupants are distanced from wall switches.

This type of basic control schedule assures that the majority of unnecessary overhead lighting is always turned off after hours, and that lighting is automatically turned off ahead of, and behind, janitorial and maintenance crews as they work.

Logical local over-ride is always available at any time, from any switch, for just that specific area. Substantial power savings will be realized, not only from containing after hours use, but also because lighting will not be turned ON the following morning until that particular office or area is actually occupied.

CONTROL OF THE SENTRY SWITCH

Interrupting OFF sweeps are generated by the scheduled pulsing of lighting contactors or low voltage lighting relays, typically installed in the electrical closets adjacent to, and in series with existing lighting circuit breaker panels. These OFF sweeps are either programmed into a dedicated electronic time clock connected to the lighting contactor panels, or may be controlled directly by a building E.M.S.

The SENTRY SWITCH uses standard mechanical switch contacts that are turned ON or OFF the conventional manner, by manual operation toggle or "switch-plate". The automatic OFF sweep, initiated by the interrupting lighting contactors unlatches the SENTRY SWITCH by means of an internal electronic sensing circuit and an unlatching solenoid. Operating power required for the unique internal sensing and triggering circuitry is generated through an integral current transformer, and stored in a miniature capacitor.

Actual "sweep" firing varies slightly from switch to switch based on manufacturing tolerances, connected load, and accumulated ON time. The following diagrams detail typical operating characteristics based on these variables.

Figure 2.

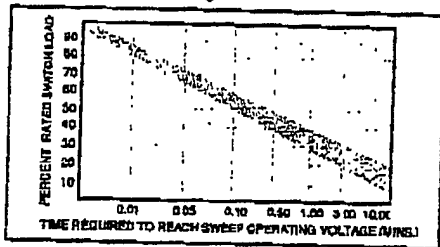

Internal circuitry commences to charge when the SENTRY SWITCH is manually turned ON.

Figure 3.

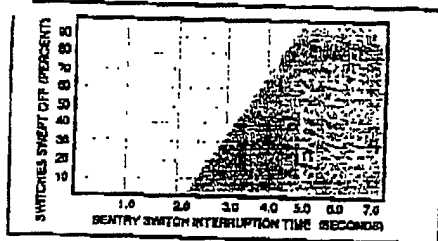

SPECIFYING THE RIGHT SENTRY SWITCH

SENTRY SWITCHES are available in two physical styles, with three electrical variants of each, designed for a specific task. The SS - STANDARD TOGGLE is produced with a clear toggle and bezel to complement switch plate hardware of almost any color or design. The SD - DECORATOR STYLE, accommodates standard "decorator" style hardware and is available in WHITE or IVORY. All SENTRY SWITCHES are U.L. listed and carry a 277V maximum rating, however all models can be used at 277 or 120V.

You will note from Figure 2, that a significantly longer "charge-up" time is required of a highly loaded SENTRY SWITCH. The "06277" designated switch provides greater sensitivity at low currents and MUST be specified if the load current is <0.8 Amps. Maximum load is 5.0 Amps. The "20277" model is for use on loads from 1 - 20 Amps and MUST be specified if the load current is >5.0 Amps. These two models are SPST two-wire switches and are not polarity sensitive. Figures 4 & 5 below detail optimum loading at 120V and 277V respectively.

Figure 4.

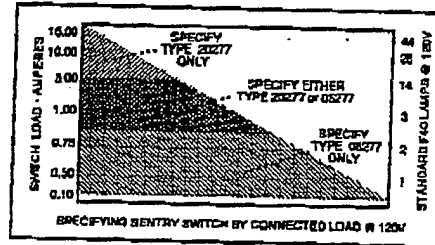
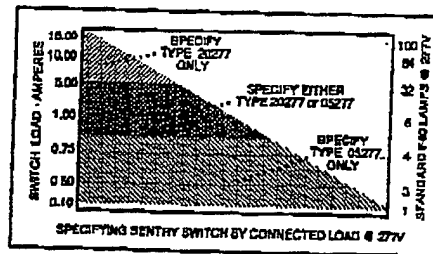

Figure 5.



The "20277" model is DPST and closely emulates 3-way operation. Configured and wired as a conventional 3-way switch, the BLACK wires connect to either LOAD or LINE and the jockey legs or travellers are cross connected RED-YELLOW, and YELLOW-RED.

DESIGNING THE CONTROLLER

Remembering the simple requirement to interrupt power to the SENTRY SWITCH for a period of 6 seconds to sweep them off, the engineer has many design options available.

If the building has an E.M.S. with sub-minute control capability, (i.e. able to be programmed in 1 second increments) and lighting contactors, a programming change will automate the SENTRY system. If the controller does not have sub-minute capability, "one-shot" relays such as the Eagle Signal 84-E-2-AB-04-05 can be interfaced to provide the required interruption interval.

Typically a single 4-channel electronic time clock will be adequate to operate even a large facility. The controller would be installed with 5 wires routed to each of the lighting contactor panels, (4 control channels and a return). At each interruptor panel, contactor coils can be grouped into control zones as required and connected to one or more of the program channels. A simple program might read:

Channel 1 - Commence sweeps at 6:00 PM continue sweeping on the hour until 2:00 AM.

Channel 2 - Commence sweeps at 7:30 PM, continue sweeping every 2 hours until 1:30 AM.

Channel 3 - Sweep at 1:00 PM, 3:00 PM and 5:00 PM, Saturday, Sunday and holidays only.

Channel 4 - Reserve for special requirements.

LIGHTING CONTACTOR PANELS

In new construction or retro-fit into an existing facility, lighting contactor panels can be specified ready-made or can be fabricated on-site. A NEMA screw cover type enclosure mounted adjacent to the lighting panel normally houses these contactors. The following are all 4P-NC 20Amp contactors suitable for this application.

- AEG Telefunken LS17-04-A
- Sprecher & Schuh CS3-04-E-120
- Klockner Moeller DIL-004-NA-120
- ASCO 917-42-031 with Acc #47-D

Touchplate or G.E. type low voltage switching panels are available in many stock configurations. These panels, when specified with two-wire control, make excellent interruptors.

Contact the factory for schematics of various control options, or current information regarding availability of Electronic Time Clocks and ready-made interruptor/contactors panels.

ORDERING INFORMATION

The following is a complete listing of available SENTRY SWITCH styles and configurations.

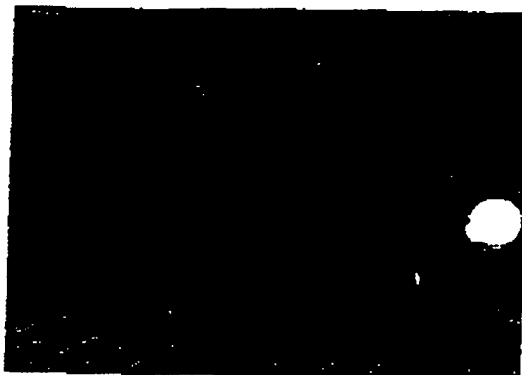

- SS 05277 - 5A 120/277 toggle type
- SD 05277/W - 5A 120/277 decorator - WHITE
- SD 05277/I - 5A 120/277 decorator - IVORY

- SS20277 - 20A 120/277 toggle type
- SD20277/W - 20A 120/277 decorator - WHITE
- SD20277/I - 20A 120/277 decorator - IVORY

- SS23277 - 20A 120/277 toggle type
- SD23277/W - 20A 120/277 decorator - WHITE
- SD23277/I - 20A 120/277 decorator - IVORY

MISCELLANEOUS INFORMATION

Many local utility companies offer generous financial incentives for installation of equipment designed to reduce lighting energy consumption. Many of these rebates are available to new construction as well as retro-fit projects. Contact your electrical utility for more information.

In California and some other states, the SENTRY SWITCH qualifies for important exceptions to state energy ordinances. Contact your state energy office or our factory for details.

